

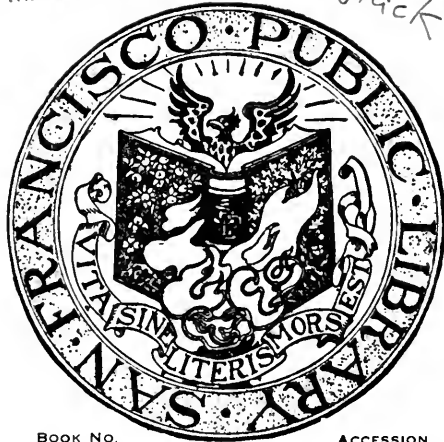

~~ART DEPARTMENT~~

ART MAGAZINE

7th stack X



BOOK NO.

ACCESSION

\*720.5 Ar24 168

592364

NOT TO BE TAKEN FROM THE LIBRARY

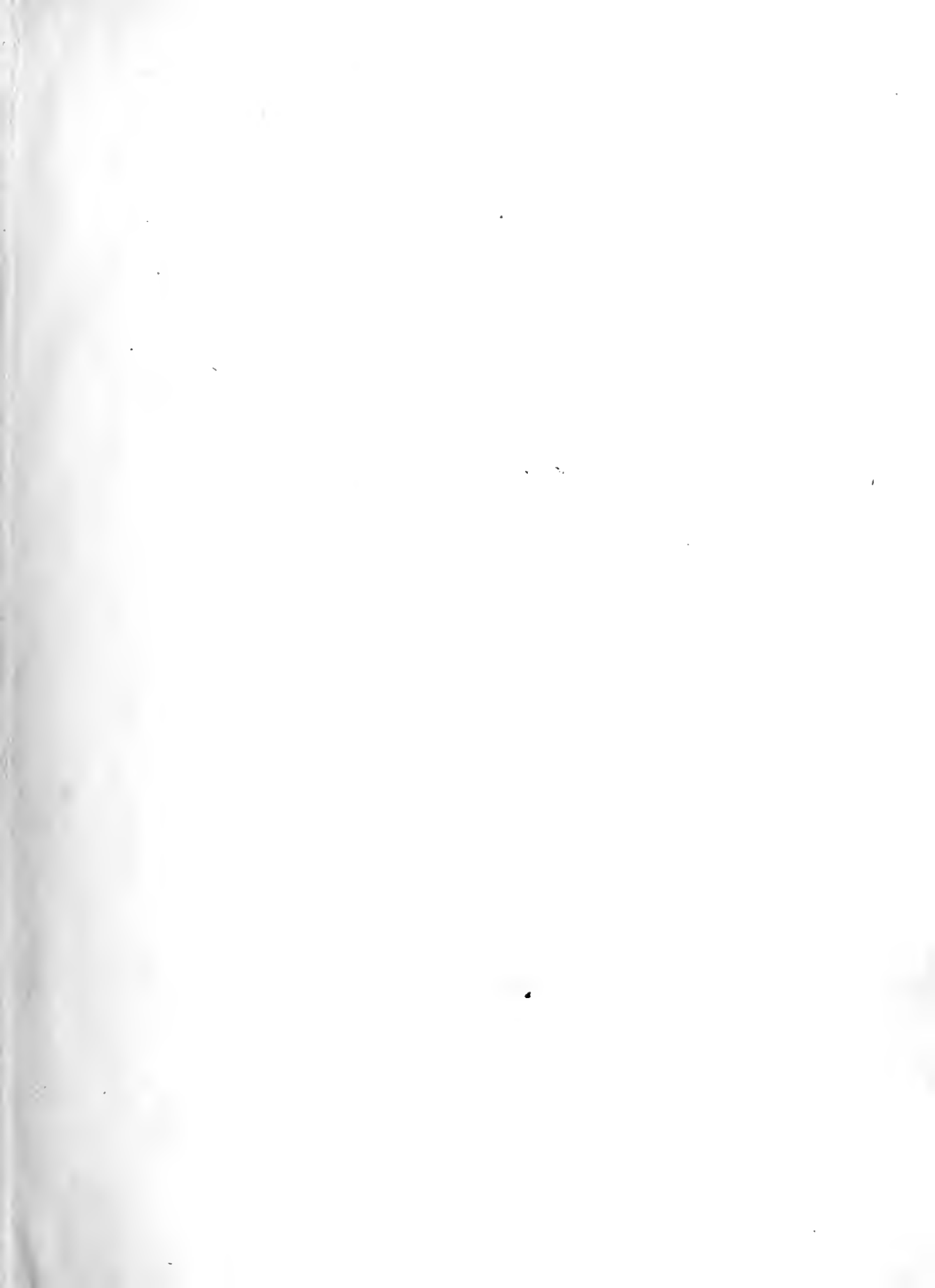





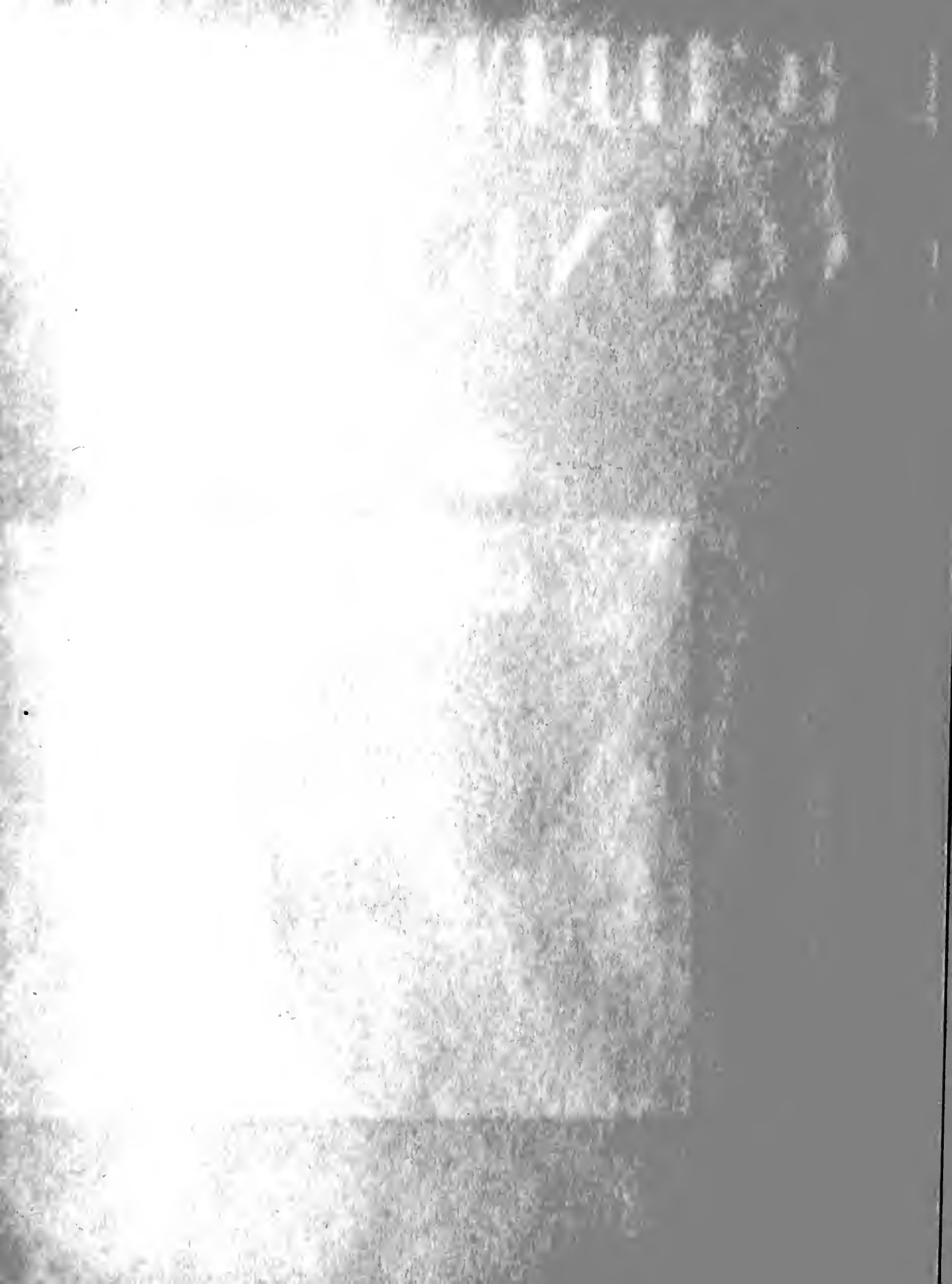

# ARCHITECT AND ENGINEER

PATIO RANCHO SANTA FE

California



JANUARY

1947

# DEPENDABLE



A  
"PACIFIC  
PRODUCT"

*Produced by*  
PACIFIC PORTLAND  
CEMENT COMPANY

San Francisco • Los Angeles  
Portland

*Sold by*  
YOUR BUILDING  
MATERIALS DEALER

# UNIFORM - TIME TESTED



# ARCHITECT

Vol. 168 No. 1

# AND ENGINEER

ARCHITECTS' REPORTS—Published Daily  
Telephone DOuglas 8311

E. H. WILDER  
Editor

MARK DANIELS, A.I.A.  
Associate Editor

JOHN S. BOLLES, A.I.A.  
Book Reviews

MICHAEL GOODMAN  
Post-War Planning

L. H. NISHKIAN  
Consulting Editor

E. N. KIERULFF\*  
Ass't Editor  
\*In the Service

Contents for



720.5  
Ar 24 168

## JANUARY

592364

COVER PICTURE: Patio Rancho Santa Fe (See Page 20)

### ARTICLES AND MISCELLANEOUS TEXT

EDITORIAL NOTES . . . . .	4
THREE WEEKS, Plus \$13,000 Builds House . . . . .	5
NEWS AND COMMENT ON ART . . . . .	6
AIR DISTRIBUTION, All Important Phase of AIR CONDITIONING . . . . . By LEONARD R. PHILLIPS, Consulting Engineer	10
ROOF GARDENS . . . . . By ALBERT WILSON, Botanist and Garden Consultant	16
RANCHO SANTA FE, A Successful Experiment in Architectural Control as an Integral Part of Community Planning . . . . . By S. R. NELSON, Secretary, Rancho Santa Fe Association	20
IN THE NEWS . . . . .	28, 29, 30, 37, 43, 44, 46, 47
A.I.A. ACTIVITIES . . . . .	31
WITH THE ENGINEERS . . . . .	32
HEADLINE NEWS & VIEWS . . . . . By E. H. W.	35
PRODUCER'S COUNCIL PAGE . . . . . Edited by CHAS. W. KRAFT	38
ESTIMATOR'S GUIDE, Building and Construction Materials . . . . .	41
BUILDING TRADES WAGE SCALES, Northern and Central California . . . . .	43
CLASSIFIED ADVERTISING . . . . .	43
BOOK REVIEWS, Pamphlets and Catalogues . . . . .	45
INDEX TO ADVERTISERS . . . . .	48

ARCHITECT AND ENGINEER (Established 1905) is published on the 15th of the month by The Architect and Engineer, Inc., 68 Post St., San Francisco 4; Telephone EXbrook 7182. President, K. P. Kierulff; Vice-President and Manager, L. B. Penhorwood; Treasurer, E. N. Kierulff.

Los Angeles Office: Wentworth F. Green, 6605 Hollywood Blvd., Los Angeles 28. Telephone HEmpstead 3171.

Entered as second class matter, November 2, 1905, at the Post Office in San Francisco, California, under the Act of March 3, 1879. Subscriptions United States and Pan America, \$3.00 a year; \$5.00 two years; foreign countries \$5.00 a year; single copy 50c. ARCHITECTS' REPORTS are published daily from this office, Vernon S. Yallop, Manager.



# EDITORIAL NOTES

## A NEW YEAR BRINGS NEW OPPORTUNITIES

With the passing of the year 1946, the Construction industry saw many obstacles in the form of wartime government controls eliminated, and much of the industry-wide restrictions which have prevented inauguration of a normal peacetime construction program have become history.

The responsibility of solving the nation's much delayed and seriously needed building expansion is now up to the construction industry itself.

A New Year, 1947, offers unprecedented opportunities to those who seek to fulfill the public's need of an expanded home, industrial, and commercial building program through the means of Individual Enterprise.

\* \* \*

## WAR MEMORIALS

A great deal of attention will soon center on the subject of War Memorials, and the A.I.A. War Memorial Committee under the chairmanship of John F. Harbeson, F.A.I.A., will soon have many valuable suggestions to offer.

\* \* \*

## A.I.A. ROSTER OF ARCHITECTS

In undertaking the preparation of a national Architects' Roster, James R. Edmunds, Jr., President of the American Institute of Architects, expressed the opinion that there is an increasing need for authentic information of Architects qualified to undertake projects of varying character, and that such a listing would accrue to a greater public recognition of the profession.

By making available a register showing the names, addresses, training, background, professional accomplishment, and abilities of architects throughout the nation, Edmunds believes the tendency towards infringement of architectural practice by governmental agencies, and to some extent private industry, will be reduced to a minimum.

Such a list has already been compiled in some localities and is available upon request of any governmental agency desiring architects qualified to handle any specific project of sizes indicated in any given area.

"Here," according to President Edmunds, "the function of the Committee and the A.I.A. terminates. The selection for the project may or may not be made from the list by the government agency involved. The selection will be entirely in the agency's hands, as no preferential listing or

advice on selection will be given by the local Committee of Review, or by the A.I.A."

Edmunds also points out that each architect has the same privilege as heretofore of seeking employment from federal agencies direct, and urges that "even though you may not be interested in federal public works," every architect should be interested in the A.I.A. Roster of Architects.

\* \* \*

## A FRIEND AT COURT

The Architectural profession now has at least one friend in Washington, D. C., in the person of Frederick A. Muhlenberg, Architect, of Redding, Pa., who has been elected a member of Congress representing the Thirteenth District of Pennsylvania.

\* \* \*

## NATIONAL PUBLISHERS' ASSOCIATION ANNUAL MID-WINTER CONVENTION

"The Magazine Industry Looks Ahead" is the theme of the national conference of the magazine industry which holds its annual Mid-Winter get-together in New York this month under sponsorship of the National Publishers' Association.

Walter D. Fuller, president of the Curtis Publishing Company and president of the Association, predicts a large attendance of magazine publishers and an outstanding series of "publishing" subjects have been scheduled for discussion.

All meetings are open to non-members, and there is NO registration fee, which is indicative that the magazine publishers welcome allied industry and the public's participation in formulation of a program to better serve readers of magazines during the ensuing year.

\* \* \*

## MODIFIED HOUSING PROGRAM

President Truman's "adjusted" housing program, under the direction of Frank R. Creedon, the new Housing Expediter, is too new to have run the gauntlet of construction industry-public's test, however, the old adage that "a new broom always sweeps clean" will probably apply in this instance.

During the adjustment period many changes in relationship between government, private-enterprise and the consuming public will probably take place—and they could be for the best interest of all concerned.

Six sets of controls are eliminated and six affirmative steps are to be followed. "The faster we can achieve—increases in production, the faster we can eliminate the few remaining controls," declares Mr. Creedon.

# THREE WEEKS Plus \$13,000

## BUILDS THIS HOUSE IN ENGLAND

One of the newest techniques of architectural engineering provides a part of Britain's rebuilding program—the **CRANWELL HOUSE**, a semi-permanent detached home.



**ABOVE:**

The completed two-story home.

**LEFT:**

Shows use of burnt clay slabs and steel.

The Cranwell House has a framework of steel girders which carry all trusses. Hollow slabs of burnt clay, three feet long and nine inches wide, are dropped into position and plastered over with white stucco to form the walls. Three bedrooms, bathroom, living room, kitchen, together with many additional features are included.

# NEWS AND COMMENT ON ART



**MADONNA  
and CHILD  
(Limestone)  
from the  
Cathedral of Metz**

## M. H. de Young Memorial Museum PERMANENT COLLECTION

**"THE  
FORTUNE TELLER"**

by  
**Gasparo Traversi**



**ST. JOHN**  
**The BAPTIST**  
by  
**El Greco**



**THE TRIBUTE MONEY**

**Peter Paul Rubens (1577-1640)**

The magnificent oil painting by the great Flemish master ranks foremost among the art works of the museum. Painted in 1612, it is an especially prized example of the artist's genius, since, contrary to many other works produced in Rubens' studio, it was completely executed by the master's own hand. The composition illustrates the story of the Pharisees who attempt to confound Christ, only to be frustrated by his admonition: "Render therefore unto Caesar the things which are Caesar's; and unto God the things that are God's."

## SAN FRANCISCO MUSEUM OF ART

The showing of the Albert M. Bender Collection now affords the rare opportunity of studying an artist's work through an assortment not only of his paintings but also his original drawings and prints.

There are numerous paintings and an unusually large number of drawings by Maurice Sterne, as well as drawings and prints by the French painters Matisse and Picasso. Marcel Verte, Dali, Marc Chagall, Carl Hofer and Fougita are some of the other artists whose drawings are to be seen.

\* \* \*

**TRUST FUND GIVEN TO MUSEUM.** The William L. Gerstle Trust Fund, which will provide an income of approximately \$750 annually, will make a continuous expansion of the collection possible, according to Dr. Grace L. McCann Morley, Director, who announced the gift.

Mr. Gerstle established the fund this year. The income may be used in a single year or accumulated, but must be devoted to the purchase of work by living artists.

\* \* \*

**CURRENT AND NEW EXHIBITIONS:** Selections from the William L. Gerstle Collection will be shown through January 15. Children's paintings from Australia and the Bay Region, and Bay Area art for museum members in the rental gallery are included in current showings.

A new exhibition—paintings and monotypes by Vicente Manzano—will be available from January 7 through 26.

\* \* \*

**ACTIVITIES:** A Christmas Story Telling Hour will feature the annual party of the Golden Gate Story Telling League, to be held on Tuesday, January 17, from 7:30 to 9 p. m.

Start to Paint, a workshop course for beginners, will be offered on Wednesdays from 7 to 9:30 p. m., from January 22 through March 12, 1947.

The children's Saturday morning art sessions, closed for the Holidays, will reopen on January 11.

Gallery talks by members of the staff on current exhibitions will continue on Sundays at 3:30 p. m. and films will be shown on Saturdays and Sundays at 2:30 p. m. However, the Famous Film series will be discontinued during the Holidays, will reopen on January 21.

## LA TAUSCA COMPETITION SELECTS WINNERS

Dr. Grace McCann Morley, of the San Francisco Museum of Art, was a member of the invitation jury composed of nationally-known artists and

museum directors who assisted in selecting the ten leading American painters as winners of the 1947 La Tausca Art Competition. Formal presentation of the first prize of \$2,000 to Abraham Rattner will be made at the Riverside Museum, New York City, on January 24.

## SAN FRANCISCO ART ASSOCIATION

A significant chapter of San Francisco's art history is being written at the moment by Anton Refregier, who has been at work on the murals of the city's Rincon Annex Post Office since last July, with artist Robert McChesney assisting. Refregier was winner of a national competition for the twenty-nine mural decorations to be used in the structure.

Five years were spent in research and in preparation of the cartoons for the murals. Ten panels have been completed to date in casein tempera.

Refregier sees the dualism of the city's history first in the struggle of men against nature and later in the social conflicts of the growing community. The panels begin with Indian life before the coming of the white man, and will end with the United Nations conference, which Refregier covered as artist-correspondent for Fortune magazine.

\* \* \*

Rose Pauson, who recently returned from a trip to New York, reports that the art from the Bay Region and California is being well received in the East.

Everywhere she went Miss Pauson saw work of artist-craftsmen of California being exhibited to great advantage, particularly in the mediums of ceramics, jewelry, and textiles.

\* \* \*

The statue of St. Therese, known as "The Little Flower," by Ruth Cravath, artist member of the association and instructor at the California School of Fine Arts, stands in the patio of the new St. Basil's Church in Vallejo.

\* \* \*

The first exhibition sponsored by the Association for the coming year is the 11th Annual Drawing and Print Exhibition to be held from February 13 to March 9.

Ray Boynton will be chairman of the exhibition and the jury of selection will include Frantz Bergmann, Robert McChesney, Hanne-Lore Nepote and Walter Landor, with Michael Goodman and Tamis Keefe as alternates.

The 11th Watercolor Annual will extend from March 13 to April 13. Alexander Nepote will act as chairman of the jury of selection, whose other

members will be Glenn Wessels, Charles Lindstrom, Emmy Lou Packard and Edgar Dorsey Taylor. Alternates are Dorothy Grover and Hassel Smith. The jury of awards is composed of Nepote, Wessels and Lindstrom.

**CALIFORNIA PALACE OF THE LEGION OF HONOR**

**EXHIBITIONS:** There will be an exhibition of paintings and sculpture sponsored by the Society for Sanity in Art through January 26th, as well as a showing of Old Master paintings from the Museum's permanent collection through the entire month of January.

During both January and February there will be an exhibition of the Arthur Sachs Collection of Old and Modern Masters, tapestries, and the decorative arts.

Other January exhibitions will include the Alma de Bretteville Spreckels Collection of sculpture by Auguste Rodin, the Mildred Anna Williams Collection of paintings, sculpture, tapestries and furniture, and the Collis Potter Huntington Memorial Collection of 18th Century French paintings, sculpture, tapestries, furniture and porcelain.

**PAINTING CLASSES:** The painting class for adults will be resumed on January 18 and will be held each Saturday afternoon at 2:30. The course is primarily for those who are not professionals but would like to do some painting. It is under the direction of Rex Mason and the admission is free.

A children's art class for ages 4 through 12, will also be resumed on January 18, and will meet at 10:30 a. m. each Saturday under the direction of Miss Katherine Parker, Mrs. Lilly Weil Jaffe, and Rex Mason.

**LECTURE SERIES:** A series of three lectures on the Arthur Sachs Collection will be given by Dr. Jermyne MacAgy on January 15, 22 and 29 at 10:30 a. m. No admission.

**M. H. DE YOUNG MEMORIAL MUSEUM—San Francisco**

The program of activities for the month of January scheduled by the M. H. DeYoung Memorial Museum, Golden Gate Park, San Francisco, according to information received from Walter Heil, Director, will include:

**EXHIBITIONS:** Water Colors by the California Water Color Society, opening January 1st.

Paintings by Ben Messick, opening January 7th.

Pioneers of American Art — Oil Paintings, Gouaches, Water Colors and Bronzes, January 5 to January 26th.

American Primitive Art, openings January 25th.

**ART CLASSES FOR ADULTS:** Conducted by Charles Lindstrom. Painting For Pleasure — A course of 10 weekly sessions designed to sharpen visual perception and to increase the enjoyment of art through a study of the fundamentals of seeing and drawing. The classes consist of both lecture and demonstration as well as experiment in the basic devices of art.

The beginning course is especially for those who, though interested in art, think they "can't draw a straight line." The same course will be given three times a week and materials will be provided.

Saturday mornings, 10:30 to 12:00 (beginning January 18) or

Tuesday afternoons, 2:00 to 4:00 (beginning January 21) or

For students from 16 to 20 years—

Saturday afternoons, 2:00 to 4:00 (beginning January 18)

An advanced course for those who have completed the beginning course in "Painting for Pleasure" will be offered on Wednesday afternoons, 2:00 to 4:00, beginning January 22nd.

The studio is open for independent drawing every day during museum hours, except Sunday, to those who have completed the "Painting for Pleasure" course.

**CHILDREN'S Classes:** Conducted by Miriam Sweeney. An intermediate class in drawing, for young people from 10 to 15 years of age, will begin on Saturday, January 18, from 2 to 4 p. m., and will be given every Saturday thereafter at the same time. The course is free and materials are provided.

\*A class for younger children from 5 to 10 is scheduled for Saturday mornings from 10:30 to 11:30.

**LIBRARY:** The Art Reference Library is open daily except Sundays and Holidays.

**CITY OF PARIS**

There will be an Exhibition of Ceramics by California potters at the Art in Action studio, City of Paris Store, San Francisco, through February 1st. In addition, there will be a demonstration of pottery weaving on Tuesdays and Thursdays.

The Rotunda Gallery is featuring a Flower Fiesta, consisting of paintings by artists of the Rotunda Circle. Assembled wood forms and flower arrangements by Alma Carlisle and Mrs. Marney Corwin complete the Rotunda program for January.



Accurate control of temperature and humidity is highly essential to the comfort of theatre audiences. Air enters this U. S. Army Motion Picture Theatre, at the Presidio, through the Anemostat air-diffusers seen on ceiling.

# AIR DISTRIBUTION ALL IMPORTANT PHASE OF AIR-CONDITIONING

By **LEONARD R. PHILLIPS**  
Consulting Engineer

In the three years prior to 1942, air-conditioning installations in the United States increased 118 per cent. During the war this trend continued and several recent surveys indicate that the air-conditioning field will be ten times its prewar size within the next decade.

What caused this 40-year-old industry to take on new life so suddenly? Air-conditioning had been in industrial use since 1906; commercial installations became fairly common in the early 1930's, and shortly thereafter air-conditioning began to appear in homes and in transportation





**LEONARD R. PHILLIPS**  
 Consulting Engineer

Mr. Phillips is a member of the American Society of Heating and Ventilating Engineers, and the New York Society of Professional Engineers. In an early association with the Dry Ice Corporation of America, he contributed importantly to the original development of applications and equipment for refrigeration with solid carbon dioxide. Before the war he was a consultant in the commercial refrigeration and air-conditioning field. Since 1942 Mr. Phillips has been in charge of the Research and Development Department of the Anemostat Corporation of America, guiding the development of new methods of controlling air with air-diffusion devices.

equipment. However, it made no rapid strides until the late '30's.

The answer to the sudden expansion can be found by comparing early air-conditioning installations with those made in more recent years.

Theatres were among the first commercial establishments to adopt air-conditioning extensively. Nearly everyone remembers the advertising that accompanied these early installations: "20 Degrees Cooler Inside," "Never Over 70 Degrees," "Arctic Breezes," and "Siberian Zephyrs."

At first the ballyhooing of these installations attracted patronage. But eventually managers of air-conditioned theatres noticed a sharp decrease in box-office receipts. They also noticed that theatre-goers avoided certain seating sections. A check of these sections indicated that they were usually either under-cooled, over-cooled, or drafty.

In attempting to rectify these conditions, theatre owners placed dampers in air-ducts, placed plaques in front of air-duct openings, closed old openings, made new openings, increased or decreased duct velocities, and tried other experiments. However, nothing seemed to bring the desired results, for in rectifying conditions in one section of a theatre, new trouble-spots usually developed elsewhere.

Even in theatres where the owners themselves considered their experiments successful, patrons continued to complain of discomfort.

This is not now surprising in view of the present-day knowledge of air-conditioning. For it is now



**Only scientific air-diffusion could afford proper air-distribution in this room with a vaulted ceiling. Here at the Bank of America, Los Angeles, air enters the room through Anemostats. Lighting fixtures are suspended from each of these air-diffusers.**



**Air-diffusers insure uniform distribution of air throughout virtually all types of public buildings. Here in the Stanislaus County (California) Court House, these devices are seen on the ceiling.**

known that to be efficient, theatre air-conditioning must afford maximum comfort during performances, yet no excessive climatic changes should be felt by a person entering or leaving the building. And this is radically new thinking on air-conditioning!

Air-conditioning engineers now know that interior climatic conditions must be changed as the exterior conditions change. Therefore, architects should work with engineers to be sure that the following conditions are maintained in their theatres:

Outdoor Average Maximum Conditions		Indoor Conditions To Be Maintained		R.H.* %
Dry Bulb °F.	Wet Bulb °F.	Dry Bulb °F.	Wet Bulb °F.	
75.....	61 to 70.....	73.....	63.....	59
80.....	65 to 75.....	74.....	63.....	55
85.....	68 to 77.....	75.....	63.....	52
90.....	70 to 79.....	76.....	64.....	52
95.....	72 to 80.....	78.....	65.....	50
100.....	72 to 80.....	82.....	67.....	45

\* Relative humidity.

From studying the above table, it is obvious why such signs as "20 Degrees Cooler Inside" have disappeared from theatre marquees. However, the knowledge that low temperature in itself would not afford comfort was one thing; solving the problem was quite another.

Even when adjustments were made to cooling and dehumidifying apparatus to compensate for varying outdoor conditions, patrons often com-

plained of discomfort. This was largely because air was still being **distributed improperly**.

In early air-conditioning installations, cooled air often entered a room through grilles, registers, or other conventional fixtures. On leaving such air-duct openings, cold air usually sweeps to the floor and forces the warmer room air to the ceiling. Until the velocity of the cold incoming air subsides, it cannot mix with the warmer room air. This results in drafts and turbulent air throughout the occupancy areas: temperature differentials are great throughout the room; humidity is unequalized, and stagnant air pockets are prevalent.

Air-conditioning engineers finally determined that such unsatisfactory conditions could be rectified only by a primary mixing of room air with incoming air from ducts well above the occupancy level of the room. They also discovered that air-velocities had to be reduced at the same time. Only in this way could conditioned air be distributed in a uniform, draftless pattern.

Extensive research and experimentation by engineers eventually led to the development of a device that would accomplish this. This patented device—known as the Anemostat air-diffuser—is attached to air-duct opening. Though seemingly simple, its scientific design instantly causes a velocity-reduction of the incoming air passing through it. Simultaneously, a phenomenon takes place: air from the room—equal to about 35 per

cent of the incoming air—is siphoned into the diffuser, where it is mixed with the incoming air.

The pre-mixed air then leaves the device at a low velocity and spreads over a predetermined area close to the ceiling before slowly settling into the occupancy area below.

These diffusers had their initial trial in this country at Madison Square Garden, New York City, in 1936. In this huge indoor stadium, these devices uniformly distributed 400,000 cfm of air in such a manner as to supply 22 cfm to each of the 18,500 spectators without causing drafts.

Motion picture exhibitors and other users of air-conditioning immediately welcomed the device as the solution to their air-distribution problems. Today these scientific air-diffusers are successfully installed in nearly 50,000 heating, ventilating, and air-conditioning systems of all kinds.

Those who attended the Golden Gate Interna-

tional Exposition may remember seeing them in the Ford Theatre, the Hill Brothers Theatre, the Mining Exhibit, the Argentine Building, and in other locations at the fair.

During the war these air-diffusers were extensively used in aircraft factories because of the exacting climatic controls necessary in these plants. Among the West Coast aircraft plants using the devices are Northrup Aviation, at Hawthorn, Calif.; Douglas Aircraft, at Santa Monica; Vega, in Burbank, and Boeing, in Seattle.

In aircraft factories and in other war plants, experience showed that close-tolerance parts—even though perfectly machined—often were impossible to assemble if turned out under different climatic conditions. Therefore, climatic conditions in one plant often had to be made identical with those in other plants.

Studies indicated that efficient air-conditioning

(Continued on Page 15)

**In New York's huge Madison Square Garden, conditioned air is distributed at 400,000 cfm in a manner that supplies 22 cfm to each of the 18,500 spectators without causing drafts. Two of the 102 Anemostat air-diffusers used in this installation are seen here.**



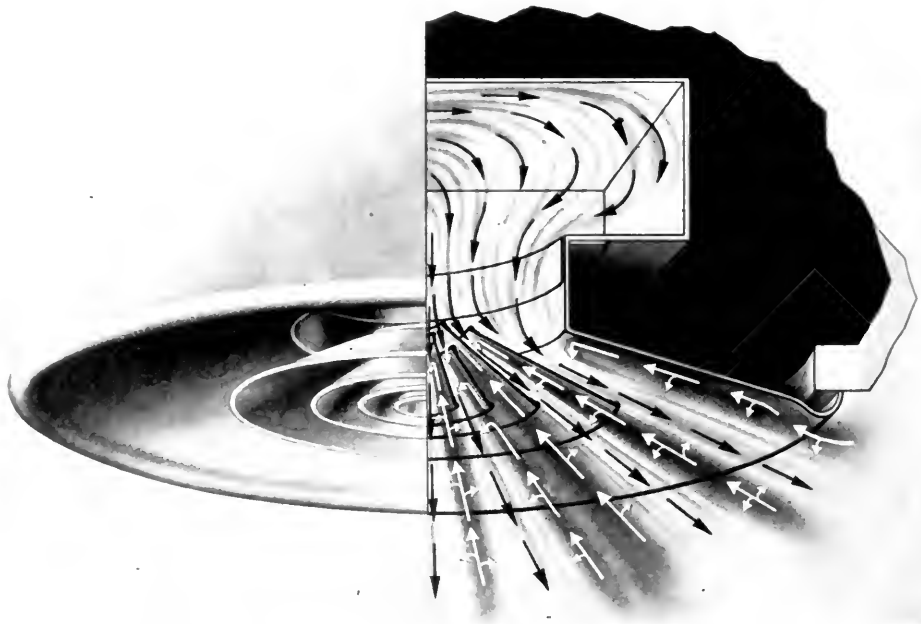

Metal cones of this Anemostat air-diffuser are designed so that the passage of incoming air (black arrows) through them siphons a series of counter-currents of room air (white arrows) back into the cones. Simultaneously, air-expansion within the cones greatly reduces the incoming air-velocity. In this way the supply air is pre-mixed with about a third of its volume of room air within the diffuser before the mixture is slowly and thoroughly spread throughout the room in a draftless pattern.

In restaurants, concentrations of tobacco smoke and other odors can be eliminated by proper air-distribution. Here, in Joe Di Maggio's, San Francisco, an adequate volume of air enters the room through Anemostat air-diffusers (with lighting fixtures attached) and is distributed in a draftless pattern.



(Continued from Page 13)

offered the logical solution to this climate-control problem, and, in addition, would quickly pay for itself through higher efficiency of workmen, improved quality in products, and a reduction in rejected items.

It was then discovered that only air-conditioning systems with proper air-distribution afforded the uniform control of temperature and humidity demanded throughout the building.

However, in most war plants it was not easy to distribute air properly. For example, in airplane factories with their vast floor areas and high ceilings, it was particularly difficult to control drafts and to circulate air uniformly. These problems were so similar to those encountered previously in theatres, that Anemostats were installed in the plants. Drafts were then eliminated, and temperature and humidity were accurately controlled by distributing the conditioned air evenly.

This was because the primary mixing of incoming air with existing room air took place within these diffusers, and because all air turbulence was limited to their vicinity high above occupancy areas.

With these diffusers discharging the air in a downward, low-velocity pattern, obstacles such as columns, machines and furniture did not deflect the air-flow. Therefore, dead air pockets—whether under-cooled or over-cooled—were eliminated.

The over-all result was even, draftless air-distribution that caused both temperature and humidity to be closely equalized throughout the room.

This scientific air-diffusion makes it possible to distribute air throughout a large or small room—as well as a convention auditorium—at low velocity, even when unusually high velocities are employed in the air-ducts. For example, in a building of the International Business Machines Corporation, 400,-

(Continued on Page 35)



**Air is distributed uniformly and without drafts over the vast floor area of this loft of the Vega Aircraft plant, at Burbank, California. By scientific air-diffusion, Anemostats (on the under-side of the trusses) insure equalization of both temperature and humidity.**

# ROOF . . . GARDENS

By **ALBERT WILSON**

**Botanist and Garden Consultant; Garden Authority of the  
National Broadcasting Company, Radio Station KPO, S. F.**

Today it's roof gardens.

This isn't a new idea at all, for the Greeks and Syrians had them, while the Romans went in for elaborate roof gardens. They had literally roof forests with plants in boxes, pots and lead urns, while the floor was often of mosaic that supported in some instances pergolas of stone over which grape vines grew. Even today the roof garden is not only for the city, for suburbans may have them, too. In fact there is an advantage in the suburban district as it is not likely to suffer so much wind, for often in the city sharper wind with bellows effect blow daily. We speak of roof, but this doesn't limit us to the house itself. There is the deck above a porch, the flat roof over a low wing connecting two parts of the house, and even the flat top of a garage may serve as a roof garden, as is often seen in Palm Springs on the desert.

We must be practical in this matter. If I were to build a roof garden I'd first consult the architect or the builder who put up the house itself. A garden on a roof with yards of soil, a ton of gravel, heavy boxes, pots of all kinds, and plants of many types, means lots of extra weight. Not to mention the people who will be invited to enjoy it from time to time, and who will be walking around on the

flooring and sitting in the furniture. The architect could investigate also the drainage problems, as it would be a great convenience to wash the floor off once in a while, and of course that rain water must leave no puddles on the roof. The architect can help also in the selection of a good floor to be put over the roof; to be sure this is a detail, but done right, especially on the almost level roof, the flooring adds strength to the design and provides comfort for walking and using the roof garden, and will help to keep things dry and keep everyone healthy.

**ROOF GARDEN BOXES in series  
banked against wall**

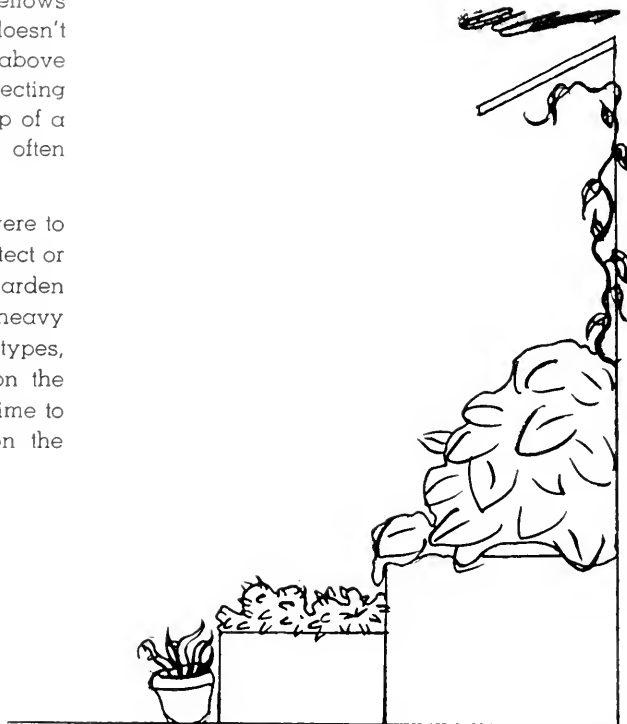

There are various ways of making the roof water proof and putting the floor above it. Gravel and tar is the most commonly used. A grating of wood is needed here because it is definitely not wise to establish a garden on a roof of gravel and tar. The wood grates can be painted slate color to keep down reflection; and the pieces spaced wide for better circulation of air. And in this detail also the more space between the roof and the floor the better. Then tile or slate make excellent floor coverings in a roof garden, and with these no wooden grates are required.

Along with the flooring the problem of safeguards at the edge of the roof must be given attention. Railings or parapets two or three feet high serve very well especially for protection and privacy. Of course where the parapet is not possible then the use of boxes of heavy plants will help.

Where is this roof garden to be: will the wind come from the north or west; will the sun shine upon it all day; just in the morning hours, or all afternoon; indeed we must take into consideration every condition of weather. Walls, you know, are climate makers; an adjoining tall building can reflect light and may lend shelter to your roof garden; or guided by your architect you may construct glass walls which will let in the sunlight, but keep out the wind. These glass walls too may be graded so that the tall sections of glass will stand where needed most, and paneled down to floor level. Glass, however, must not be allowed to burn the plants.

My own experience in developing a roof garden has been limited to a few in San Francisco and Palo Alto, so when asked to discuss the subject, "How Does Your Garden Grow?" I remember Mr. George Kelley who is with Martin and Overlach in San Francisco, and who has put in hundreds of roof gardens. He's our man; let's tackle him, for I know he will hand out the information graciously. Imagine my delight when he said, "The Plan's the thing; make up your mind what you want; get the picture and work for it."

Why those words are like preparing for the garden itself. The plan's the thing; what a simple truth. Of course that roof garden can't grow all over everywhere; there must be a background, there must be a margin, there must be an open area because the situation, the purpose of this roof garden, and the character determines the dimensions. I remember, when a student, drawing plant cells I saw through the microscope but drawing them as big as cobblestones all over the paper, Professor Douglas Houghton Campbell telling me

time and again, "watch your proportions." The roof garden more than the garden out-doors must give the effect of calmness to the place. Time of course can soften the newness of the materials, but the open area in the design, being level and as wide as possible, providing an intimate foreground for the distant view offered from the roof, must be considered a complete garden unit in itself.

But what is the purpose for which the roof garden is to be used. Perhaps it is to be for seclusion and rest; then none but the best in furniture should be used; furniture which can take any weather, which would not require a dash to the roof with every cloud that floats by. Perhaps it is to be an outdoor living room. But let us say you have determined to have it a real garden with life for all year round. In this there is the question of the effect desired; shall it be formal? An advantage of the formal design is you can plan for the color and effects during the seasons. In the formal roof garden there may be little hedges of boxwood or plants trimmed to globes and pyramids, with flower beds laid out in geometric patterns with good straight lines because the area is usually so small. Formal gardens tolerate no spotty effects. In this formal roof garden advantage of all walls may be taken by stepping up the boxes with the shallow ones in front, the high boxes in the rear; and along high walls, interesting effects may be established by a pattern of trellises. The stepping up of the boxes as well as the trellises create an illusion of perspective. Trellises lend height, covered with a ravishing mantle of bloom they take away severity; in fact the only solution for a wall is a pattern; the wall is there for a purpose, it should be ornamented. Remember the quick growing Boston Ivy with its abundant foliage—it will completely annihilate a wall and do the job beautifully too.

Then some roof gardens will be for display, a show of quick fancy color; in this, it is best to select plants that can take it, both as to drought and heavy weather. What beats cinerarias, or calendulas in winter, or violas and pansies in spring; petunias and lobelia in summer, and chrysanthemums in fall?

Those expressing themselves in a roof garden as in the conservatory must indeed be lovers of flowers and plants. The roof garden requires lots of fuss and regular changing; perhaps not much weeding, but certainly a daily routine of care must be followed. Best of all know that roof, for sun light, shadows and wind. But when one's home is the roof what could give greater joy than to walk right out into the garden there.

All containers must be of durable materials. And

## ROOF GARDENS . . .

it is best they rest on wooden slats, up above the roof in order that air may circulate freely. Boxes and tubs should be tarred inside especially up to the soil line, for it is along this line where rotting takes place so readily. Careful attention to size of containers is important because more nursing is required if too small; greater drying out takes place; boxes therefore should be eighteen inches to two feet deep, and two feet wide. Of course for the annuals, low boxes in front may be only six inches to one foot deep because their roots are shallow. If cost is not a serious item, it serves best for the picture to use containers of one kind, better unity may be had with graded sizes of containers made of similar materials. Be suspicious of outlandish, garrishly painted pots, of baby's old bath tub, of cracked pickle jars, and those kitchen water tanks of a generation ago, that having burst, rightfully belong to the junkman instead of being given a place in the roof garden. Especially be careful of trashy souvenirs thrown out into the roof garden.

Drainage is our next problem; just as the roof itself must carry away the water, so in each box, pot, and container ample drainage must be provided, and as mentioned already keep the boxes up off the roof floor. For the large boxes and tubs use large size gravel, in some cases as big as chunks of coal, this covered with a layer of sphagnum moss, so the soil won't go out into the drain pipes; for shallow boxes and pots regular pea sized gravel will be alright. In all cases of course use it thick enough, at least one inch deep.

Then we must consider the soil. This is important all round. To begin with use the nest available, good fresh soil, soil that's been kissed by the sun, soil that's full of humus, because when it goes into these boxes and containers something happens to it, and it loses its sweetness. Every year the professionals follow a system of lifting out the permanent plants, replacing the soil, in the shallow boxes and small pots, and resetting the plants. In the large containers they usually fish around and take out as much of the old soil as they can without tearing roots to pieces and replacing with a fresh well mixed compost. This to get away from the constant packing and souring of the soil due to the system of watering. Then of course fertilizer must be applied each season; not the rough smelly stuff, but well rotted, chopped up cow manure for bulk and humus build up, and then of course the old standbys in the commercial fertilizers. Mr. Kelley says, "For summer time a good old manure mulch is fine because it provides food

and cuts down the water problem as the humus material, like a sponge, holds on to the moisture. But those of you who are planting a new roof garden will not have to feed your plants for the first six months, maybe a year, but following this period a regular program of fertilizing the plants must be established." I like the way he put it when he said, "Those plants are going to live from these boxes and tubs, they can't send out their roots to get more food as they can in the garden."

What about the watering? I asked Mr. Kelley. "You can't establish a rule for that. Go by the feel and the looks of the soil. You can't say once a week, nor twice a week, the conditions of weather, sun reflection from the hot roof, wind and exposure all modify the moisture requirements of your plants in the roof garden. But when you apply water," he went on, "be generous, thoroughly saturate the soil, for drainage will take care of excess, and the normal requirements of the plant at hand will use the rest of the water."

Of course you and I know insects and bugs fly up in the air as well as low down in the garden. When I was at Berkeley some butterflies flew into the roof garden, and a humming bird came to the fuchsia. So the roof garden has its animal population too. But one thing, they don't have the gophers; and the snails, slugs and ants can be kept out by keeping guard. But aphid, mealy bug, scale, and flies will reach the roof garden. And if one is not careful the whole picture may be ruined by these offensive intruders. Mr. Kelley had a fine suggestion there, he said, "Don't wait till the insects come, be Johnny on the spot ahead of them. Clean house regularly, spray every six weeks. Use Whale oil soap, Volck, Nicon, your favorite insecticide, whether you see bugs or not, and you'll find there won't be any, because even the odor of these sprays will keep away the enemies." More than that we must realize up on the roof we are in the zone of chimney smoke, and of course in dust too. So with a fine nozzle spray water over head once in a while; the fine misty spray will do wonders to keep off dust and soot; it will discourage insects in the bargain. Ivy in particular can become actually black with dust and soot. With some of the larger plants like aralia and aspidistra use Nursery Volck, freshly mixed up in your tank, and spray it with force on both sides of the leaves, douse them, do a good job and make them shine. But don't use any of the oil sprays on the succulent plants (if you do not know what a succulent is, ask your nurseryman) because the oil discolors



them and may even burn too. A carton placed over them will protect them during house cleaning.

What plants are best for the roof garden? First of all stay away from fliers: magnolias, loquats; large leaved plants susceptible to wind injury are not good up there. The evergreens are much better, and against heavy walls and panels, Lawson cypress, Hinoki cypress, Popocarpus, feather duster Palms, and Eugenia serve excellently. And for the trellises the Star Jasmine, Burmese Honey-suckle, and Climbing Roses, Hoya carnosa, where protected somewhat blooms faithfully every year, and the sweet smelling Mandevillia, along with other favorites provide color, fragrance and interest throughout the seasons. Then for plants of a smaller stature, ones providing atmosphere to the roof garden picture, there are Eleagnus, Sacred Bamboo, (*Nandina domestica*) and Genista, but change to new ones every second or third year because the plants get raggy looking. Try a Poinsettia against a warm wall; and there are heathers for strong color in winter. For the shady places there are Fuchsias, Hydrangeas, the Gold Dust Plant, Abutilons, some people call them Chinese Lanterns, and for the Spring season there are the Camellias, Rhododendrons and Azaleas; the fragrant *Viburnum carlesii*; and let's not overlook the Japanese Maple, with its wine colored leaves unfolding in Spring; and turning red and gold in autumn. But with these plants particularly keep the soil in good condition, maintain the proper tilth with peat and leaf mold because all of them become bedraggled and unhappy if the soil packs and gets bad.

Then there are the perennials like *Penstemon*, blue natives, or hybrid red, white, lavender or pink flowers, Marguerites, both white and cream colored, *Coreopsis* with bright yellow flowers for summer, blue *Salvias* to stand up tall in the background, Sweet Williams always attractive, Carnations the favorite of many, even Valerina which you can depend will establish itself anywhere and bloom for ever more. The Garden Geraniums of all colors, and the trailing Ivy Geranium, that particularly serve so well in boxes; get them young, pinch them back, keep them from getting leggy, and up on the roof or in the window box they can't be beat.

And the flowers which do so much to bring the seasons to the roof garden. For example: Begonias, Lobelias, Marigolds, French and African Petunias, *Ageratum*, Zinnias, and hybrid Dahlias all for

summer. In cool San Francisco even cyclamen may be used. And as the year moves along there are Pansies, Snapdragons, Violas, Nasturtiums, all of the bulbs, as Daffodils, Hyacinths, and *Gladiolus* too; and a *Mesembryanthemum* may be tucked in to give its bright color to the roof. And Cosmos and Pin Cushions can be grown along with Tomatoes and Beans as I saw in Berkeley on a roof garden there.

Mrs. Eileen Gill who has a roof garden in San Francisco says:

"First think of Protection: protect your plants—lath—glass—any sort of wind break.

Second: Right Kind of Plants: Do you want color in your life—Do it with annuals (the landlord may move the rent up if it's perennials.) Get something gay: Nasturtiums, Lovelias, Violas, Pansies may be planted around the base of tubs to add color.

Third: You cannot afford to experiment in a small space. Buy the best. Each flower and each bloom is seen by you over and over. In a ten acre tract you don't look so often.

Fourth: Do not use painted pots. Pictorially interesting but from a gardener's view point detrimental. (Let me interject here; the terracotta, the glazed, the Chinese Porcelan, and Mexican pots are all good).

Fifth: Soil: Keep it light, keep it light. Aerate. Use leaf mold and good fertilizers. Sixth: Keep yourself interested. Go to garden shows; buy a new plant, be selective, throw out the weakies. And here again let me add: forget this economy business, 'I'll save that to grow it on for next year.' Many times Christmas gifts and Easter plants are through when the season is over; you take them out to the roof garden, or plunge them into the window box, and the first thing you know you have out there a jangle of second rate, messy foliage plants. Better economy by using less and nice plants rather than keeping yourself busy doctoring a spent plant.) "Don't try to grow Lemon Trees on a roof in San Francisco."

Seventh: Your roof garden can be a conversation piece. You can make your roof garden work for you. Succulents can come down from your roof garden, be on your dinner table and return the next morning, having added conversation.

Eighth: You can lie in the sun, surrounded by plants that you have worked with and loved and tell, 'How does your garden grow'."



A portion of one of the Rancho Santa Fe buildings

# RANCHO

## A SUCCESSFUL EXPERIMENT AS AN INTREGAL PART OF

By **S. R. NELSON**

**Secretary, Rancho Santa Fe Association**

Twenty-five miles north of San Diego and five miles inland from the Pacific is Rancho Santa Fe, an interesting example of architectural control applied in successful community planning.

The principles by which this Southern California community has been guided originated some twenty-six years ago in the office of the late W. E. Hodges, then vice-president of the Santa Fe Rail-

road. Through a subsidiary company, the railroad owned a 9,000 acre Spanish land grant, now the site of Rancho Santa Fe, and, through another subsidiary, a nearby storage reservoir and water system. The Santa Fe was interested in colonizing the land, encouraging horticultural development, and thus adding to freight revenues.

Advising Mr. Hodges was a consultant on com-



Constructed in 1835

# SANTA FE

## IN ARCHITECTURAL CONTROL COMMUNITY PLANNING † †

munity planning, who saw in the gently rolling hills of this property, which combines fertile valleys with commanding home sites, the ideal setting for a development of country estates that would appeal to people of culture and means by providing a source of income combined with gracious living conditions.

At that time use of protective restrictions and

architectural control in urban community planning was not uncommon, but rural areas were slow to adopt this means to combat the unsightly fringe of shacks, bill boards, and hot-dog stands which line many of our country highways, defacing the native landscape. Since compliance with restrictions necessitates a greater investment by the buyer, real estate subdividers, fearing high sales re-



**The  
Inn  
at  
Rancho  
Santa Fe**

**A combination of flowers, lawn, and shade trees**

sistance from purchasers, hesitated to incorporate them in rural and suburban developments.

But, acting upon the advice of the community planner who believed protective restrictions the means to insure a more substantial quality of improvements, Mr. Hodges adopted this policy in his work with Rancho Santa Fe.

Today control of this community planning is vested in the residents themselves through the medium of a protective covenant mutually agreed upon by the property owners. A non-stock, non-profit corporation known as the Rancho Santa Fe Association, to which all property owners belong

administers the protective policies established in the covenant through an annually elected Board of Directors, who, in turn, appoint an Art Jury consisting of a licensed architect and two resident property owners to review all plans for new construction in the community.

Home seekers from every part of the country have discovered in Rancho Santa Fe a place free from the annoyances of congested city life yet assured of pleasant, harmonious surroundings. An exceedingly temperate climate with mild, warm days even during the greater part of the winter season enables architects and landscape garden-

(Continued on Page 24)



**TOP VIEW:** Shows the swimming pool court at THE INN. Large pool has been completely surrounded by landscaping of flowers, shrubs, and trees.

**BELOW:** Practice putting green and the Rancho Santa Fe golf clubhouse.



## RANCHO SANTA FE . . .

ers to utilize fully the benefits of our-door living, an increasingly important element in Southern California home design.

Though no one type of architecture is emphasized, a requisite of all construction is that it blend naturally with the surrounding landscape. Perhaps for this reason, Mediterranean and the California ranch house designs are those most frequently used. Landscape planning is directed toward maximum use of native trees and shrubbery rather than toward formal plantings. Full

advantage is taken of the graceful qualities of the eucalyptus trees which cover large sections of this area.

The casual visitor to this community is impressed with the successful realization of such well thought-out planning, for today its value is increasingly evident. Rancho Santa Fe is essentially a community for families, both those with children and those which, though adults, wish to establish homes. Attractive, modern schools are provided

(Continued on Page 27)

**THE OLD JUAN OSUGA ADOBE: Nestled among giant trees and beautifully landscaped this adobe was one of those built on the site of the present-day Rancho Santa Fe in 1845.**





**MOUNTAIN VIEW** from Rancho Santa Fe. Rugged mountain country of San Diego County is seen to the East, while adjoining to the West is the calm, blue waters of the Pacific Ocean.

**TYPICAL RANCHO SANTA FE VISTA**, embodying the romance and adventuresome appeal of early Spanish-California.





HERE IS A TYPICAL RANCH HOUSE

Lennart Palme, Architect

LIVING ROOM and Dining Room. The large sliding doors, which lead to a spacious, semi-covered area, combine indoor and outdoor living.

LENNART PALME, Architect







**"COMO ESTA AMIGOS"; the rock-walled lily and gold fish pond; spacious lawn and shade trees centered in flower beds; the sun protected porch, and a definite home of "Spanish" influence, makes this Rancho Santa Fe residence a "California dream."**

for its children, and freedom of space to grow up in healthy, out-of-doors surroundings. Leisure time activities for adults as well as young people are many and varied, outstanding among them the facilities offered by one of the finest golf courses in California, owned by the people of the community themselves and managed by their Association. Nearly two thousand acres of citrus demon-

strate the productivity of this area and contribute substantially to its income.

The people of this community advocate enthusiastically the benefits of careful planning and architectural control of all homes, regardless of size. They take pride in their own part in developing and carrying out these policies, and they are the first to point to Rancho Santa Fe as an outstanding example of community planning.



**ONE OF THE FIRST RESIDENCES in RANCHO SANTA FE**

## ANGIER PACIFIC CORPORATION UNDER NEW CORPORATE STRUCTURE NOW SERVING WEST

January 1st, the newly organized Angier Pacific Corporation became operative under the corporation laws of California. It was formerly the Angier Sales Corporation, handling distribution in the eleven western states for Angier Corporation of Massachusetts, manufacturers of protective building and industrial papers.

According to Paul Ayer, vice president and general manager in charge of sales, the new organization has been established to provide service patterned to the expanding needs of the rapidly developing western region.



PAUL AYER

Founded in 1898 by E. H. Angier, who continues today as chairman of the board, the Angier Corporation first manufactured a reinforced protective wrapping paper for electric motors. Westinghouse and General Electric were first users of this product and continue its use today. Mr. Angier, developer of the product, next perfected a special crepe paper to be used as a spiral wrapping for coils of wire, tire and hose. He also invented and put into use mechanical wrapping machines for the application of the new paper. The discovery and development of special papers for special jobs has been a continuing policy with the company.

Just prior to the recent war, Angier developed an anti-corrosive paper which was used as an interleafing material between sheets of stainless steel by major steel mills. When the war came and it was vital to keep critical steel parts protected from corrosion while being shipped to the many varied combat areas and under a wide variance of weather conditions, this paper was used extensively and proved invaluable as an anti-corrosive, protective paper. It is marketed today as Indu-wrap.

In 1935 E. H. Angier, not satisfied with the building papers then available, developed a new line. This paper which introduced new qualities in building papers as a resiliency and water-proofing

is on the market as Brownskin. It has been specified throughout the nation by major architects and engineers over the years since its introduction.

The company recently completed an extensive laboratory, which under the name of Angier Research, a separate enterprise from the manufacturing and sales companies, is devoted to solving protective problems found in building, construction and industrial fields.

The headquarters for the Angier Pacific Corporation are located at 116 New Montgomery Street, San Francisco, with branch offices in Los Angeles and Seattle. The company has distributors or dealers in all major western cities. Western Asbestos Co. distributes to the building field in northern California and western Nevada, Asbestos Supply Co. covers the northwest with offices in Seattle, Spokane and Portland. In Los Angeles, Angier products are distributed by Security Materials, Asphalt Products and Warren Bailey Co. The R. W. Frank Co. covers the intermountain area with headquarters in Salt Lake City. And in southern Idaho the distributor is J. G. Doerr of Boise. All major western paper distributors handle Angier protective wrappings in the industrial field. Among these are Zellerbach and Blake, Moffitt and Towne.

Angier products are distributed in Honolulu by the Honolulu Paper Co. and the Taylor Pacific Co. who also distribute in the far east including the Philippine Islands.

Paul Ayer, who will head up the operations of the Angier Pacific Corporation, has represented Angier Corporation in the west for the past twelve years as a sales engineer on the Pacific Coast. The Los Angeles branch is managed by Jack O'Connor, whose association with Angier began in 1937. The Los Angeles office is located at 1702 North Vermont Avenue.

---

### ELECTED TO EXECUTIVE COMMITTEE

R. W. Truesdail, Truesdail Laboratories, Inc., of Los Angeles, was elected to the Executive Committee, American Council of Commercial Laboratories, at the recent annual meeting of the council held in Chicago, Ill. Truesdail's term is for the year 1947.

# IN THE NEWS

## **AMERICAN CONCRETE PIPE ASSOCIATION CONVENTION**

The annual convention of the American Concrete Pipe Association will be held on February 23, 24, 25, in St. Louis, Mo., according to Howard F. Peckworth, managing director of the Association.

A series of technical papers, election of officers, and the annual dinner will highlight the program.

Attendance of industry members from England, Canada, and the United States is expected.

## **INDUSTRIAL DESIGNERS ADOPT CODE OF PRACTICE**

The Society of Industrial Designers recently adopted a Code of Practice in order to guide members in their relation with the public and with each other.

The designers agreed that they would accept no remuneration from any source other than the client who hires them, and not to work for competing clients except when agreeable to each other.

They also agreed that the formation of corporations in the industrial designing field is not in the best interests of the profession as a whole. They feel it wiser to adhere to the standards of the older professions of architecture, law, and medicine.

## **PACIFIC REGION LEADS NATION IN BUILDING**

Pacific Coast States are leading the nation in non-farm home building, according to the Civilian Production Administration.

Texas and the Mountain States are also building a larger share of the nation's homes than they did during the same period of 1941.

The CPA points out that transplanted industries and attendant population shifts partly explain the difference between the 1941 and 1946 housing pictures. Distributors are warned to take heed of changing marketing prospects resulting from these shifts.

## **HOME BUILDERS TO MEET IN CHICAGO**

Reports received indicate the annual convention of the National Association of Home Builders to be held at the Stevens Hotel, Chicago, Feb. 23-27, will have a greater attendance than last year, when over 5000 builders gathered for the four-day session.

Subjects to be discussed at the convention will include such topics as apprentice training, wages,

productivity of labor and the outlook for veterans' housing.

A great panorama of the building industry is being planned to be held in conjunction with the convention. Paul S. Van Auken, Exposition Director, expressed great enthusiasm in describing prospective displays. "Last year we saw what manufacturers wanted to make; this year we will see what they are making," he said.

## **WEST COAST STEEL COMPANY EXPANDS**

Completion of the million dollar expansion program of the Caine Steel Company of Emeryville, California, next March, will give the Pacific Coast a modern steel supply and servicing facility.

The Caine Company has been engaged in the distribution of steel for the past 25 years and operates seven warehouse plants throughout the country. Recent growth necessitated the move from the company's present location in Oakland.

## **NEW LIGHTING CENTER OPENS IN NEW YORK**

The newly restyled rooms of the Sylvania Lighting Center were formally opened in New York recently, where the latest techniques of efficient and decorative lighting were displayed.

Such innovations as a special lighting arrangement permitting a group of people to enjoy a television show while others in the same room read or play cards, a kitchen equipped with fluorescent lamps concealed in the cabinets, and a combination bedroom-den lighting arrangement were highlighted.

## **VETERANS ASSURED BY HOME BUILDERS ASSOCIATION**

Assurance that the relaxing of controls on home building will promote veterans' housing, rather than implying a "scuttling" of their program, came from the National Association of Home Builders in a recent announcement.

"The clearing out of detailed control of home building enforced by the government should result in building more houses for veterans in less time," Joseph Meyerhoff, NAHB president, declared. Veterans should be relieved, not alarmed, he said.

"The actual fact has been that the energy of the Housing Expeditors' office in recent months has been dissipated in a mass of regulations and has not been devoted to seeing that finishing materials are provided for houses that have been started," he continued. "Abandonment of complex regulations will spell production. The home builders of the nation are ready."

## IN THE NEWS

### CONSTRUCTION TREND

It has been estimated that of the \$9.2 billion value of new construction for 1946, about \$3 billion will be spent on permanent-type non-farm housing.

Wilson Wright, chairman of the Market Analysis Committee of the Producers Council, predicts that "Construction expenditures are expected to rise to about \$11.7 billion in 1947 and to average about \$14.6 billion in 1948 and 1949."

Economic uncertainties, based upon the low interest rate policy of the U. S. Treasury and unbalanced Federal budget, make it impossible for the Committee to predict past the 1949 period.

### MOVES TO NEW OFFICE

Architect Francis E. Lloyd has moved his office from 210 Post St., San Francisco, to 305 Grant Ave., San Francisco.

### AIR-CONDITIONING PURIFIER DEVELOPED

A new filtering unit containing activated carbon provides the basis for an air-conditioning purifier that will make it possible to bring country-air fresh-

ness to crowded public places, according to a recent announcement of the Carbide and Carbon Chemicals Corporation, who developed the process.

### REVISION OF ELEVATOR SAFETY CODE BEGUN

The American Standard Safety Code for elevators, dumbwaiters, and escalators, sponsored jointly by the American Institute of Architects, the National Bureau of Standards, and the American Society of Mechanical Engineers, is being revised.

Ten subcommittees are at work on the project and have under advisement testing and certification of safety devices which have been submitted since last revision of the Code.

### LARGE SCALE PRODUCTION OF PANEL HOUSES PLANNED

A 1947 production schedule of 10,000 four-room houses to sell for \$4500 is planned for the Pacific Coast by the General Panel Corporation of California, according to a recent announcement.

The houses to be constructed entirely of interchangeable insulated plywood panels will have two bedrooms. The \$22,000,000 building program was launched by the corporation upon receipt of a letter of intent from the National Housing Expediter.

Distribution will be in the hands of the Celotex Corporation, which recently entered into an agreement with the General Panel Corporation of New York, parent company of the California concern.

George E. Swenson, a director and assistant to the president of the Celotex Corporation, will serve in a liaison capacity between the distributors and the General Panel Corporation of California, who will manufacture the revolutionary panel house.

General Panel of California has been awarded a guaranteed market contract by the Reconstruction Finance Corporation for the production of 8500 plywood prefabricated dwellings by the end of 1947.

### FUEL IN BRITAIN

If American architects are wondering what their British cousins are thinking about, the answer is: coal.

According to a recent issue of The Journal of The Royal Institute of British Architects, Minister of Fuel E. Shinwell told the assembled architects that many traditional British building and heating methods would have to be changed because of the shortage of coal. He foresaw no early improvement.

### GOOD CONSTRUCTION DEMANDS

3 HINGES TO A DOOR



# A. I. A.

## American Institute



# ACTIVITIES

## of Architects

### Arizona Chapter:

James Macmillan, President; Arthur T. Brown, Secretary, 749 N. Country Club Road, Tucson, Arizona.

### Central Valley of California:

Herbert E. Goodpastor, President; Frank V. Mayo, Secretary, 307 Exchange Building, Stockton 2, California.

### Colorado Chapter:

Raymond H. Ervin, President; James M. Hunter, Secretary, 2049 Broadway, Boulder, Colorado.

### Montana Chapter:

Ralph H. Cushing, President; H. C. Cheever, Secretary, Montana State College, Bozeman, Montana.

### Northern California Chapter:

Andrew T. Hass, President; John S. Bolles, Secretary, 369 Pine Street, San Francisco 4, California.

### Oregon Chapter:

Francis Jacobberger, President; J. D. Annand, Secretary, 401 Central Building, Portland 5, Oregon.

### San Diego Chapter (California):

H. Louis Bodmer, President; Louis J. Gill, Secretary, 203 Granger Building, San Diego, California.

### Santa Barbara Chapter (California):

Roy C. Wilson, President; Miss Lutah M. Riggs, Secretary, 240 Middle Road, Santa Barbara, California.

### CALIFORNIA COUNCIL OF ARCHITECTS

John S. Bolles, President; Charles O. Matcham, Vice-President; James H. Mitchell, Secretary-Treasurer; 369 Pine Street, San Francisco 4.

### Southern California Chapter:

Charles O. Matcham, President; John Landon, Secretary, Chapter Headquarters 3757 Wilshire Blvd., Los Angeles 5, California.

### Spokane Chapter (Washington):

Noel E. Thomson, President; Kenneth D. Storment, Secretary, Hutton Building, Spokane, Washington.

### Utah Chapter:

George Cannon Young, President; Theodore R. Pope, Secretary, 29 South State Street, Salt Lake City 1, Utah.

### Washington State Chapter:

George W. Stoddard, President; Stephen H. Richardson, Secretary, 516 Central Bank Building, Seattle 4, Washington.

### Hawaii Chapter:

Kenneth W. Roehrig, President; James Morrison, Secretary, 334 Federal Bldg., Honolulu, T. H.

### SOUTHERN CALIFORNIA CHAPTER

Since there was only one nominee for each office, ballots will not be sent to Chapter members in the 1947 election of officers. In accordance with the by-laws, the following nominees will be declared officers by acclamation:

President .....	Adrian Wilson
Vice-President .....	A. C. Martin, Jr.
Secretary .....	Walter L. Reichardt
Treasurer .....	George E. Gable
Director (3 years) .....	George B. Allison

### To Elect Council Delegates

Delegates to the California Council of Architects will be elected at the next meeting of the Chapter.

The Chapter president is a delegate by virtue of his office. Four additional delegates will be chosen, three from the Executive Committee and one other, who may be either a member of the Committee or a nominee from the floor. All members and associates are eligible for nomination.

### Membership Increases

Institute Members .....	309
Associates .....	28
Junior Associates .....	90
Total Increase for 1945 .....	20.3%
Total Increase for eleven months 1946 .....	36½%

### New Members

Architects accepted by the Institute as new members were: Harold James Bissner, Earl Gray Boehm, Alexander R. Brandner, Frederick N. Clark, Winston A. Cordes, Ralph Mitchell Crosby, Charles Walter Hobson, James Harmon Hoose, DeWight Ingham Kindig, Guy Oran Koepp, Jack Carroll

Lipman, Louise Shoall Miller, Arthur C. Munson and Homer D. Rice.

### New Junior Associates

Several new junior associates were also received. They were: Sara Ellen, Waldner Bould, Anna Perry, Wood Dennison, Milton Elliott Gardner, John J. Kewell, James Charles Rice, Jose E. Sala and Robert Alfred Schoenberner.

### WASHINGTON STATE CHAPTER, A.I.A.

### CASH PRIZES OFFERED FOR SMALL HOME DESIGN

Cash prizes for the design of small homes will go to the winners of the 1946 Architectural Competition sponsored by the Seattle Trust and Savings Bank, the Washington State Chapter of the American Institute of Architects recently announced. All licensed architects of the State of Washington are eligible to enter the contest.

Purpose of the competition is to stimulate interest in small home construction and to assist in the design of homes adaptable to needs of the veterans' housing program as well as a step toward solving the housing problem for the low-income group.

The first prize is \$300, the second \$200, and the third \$100. Only small home designs will be considered, and a maximum of 900 square feet of livable floor space has been established.

All houses must be capable of being constructed with existing available materials, and must conform to minimum F.H.A. requirements as well as the City of Seattle Building Code.

(Continued on Page 40)

# WITH THE ENGINEERS

Structural Engineers Association of Northern California

William W. Moore, President; John A. Blume, Vice President; Franklin P. Ulrich, Sec.-Treas.; Offices 214 Old Mint Bldg., San Francisco, Phone GARfield 3890. DIRECTORS, Mark Falk, M. V. Pregnof, and R. D. Dewell.

American Society of Civil Engineers San Francisco Section

Theodore P. Dresser, Jr., President; Leon H. Nishikian and Sidney T. Harding, Vice Presidents; John E. Rinne, Secretary-Treasurer; 225 Bush St., San Francisco 20.

Puget Sound Council (Washington)

Engineering & Technical Societies

R. E. Kistler, A. I. E. E., Chairman; A. L. Miller, A.S.C.E., Vice-Chairman; L. B. Cooper, A.S.M.E., Secretary; B. A. Travis, I.E.S., Treasurer; Offices, Seattle, Washington.

## STRUCTURAL ENGINEERS ASSOCIATION OF NORTHERN CALIFORNIA

At the annual meeting of the SEA the accomplishments of the association under the presidency of W. Adrian were reviewed.

Among the more significant undertakings was the establishment of regular contact with the California Council and the Northern California Chapter of the AIA, as well as with other engineering, contracting and building groups.

A campaign for the adoption of new building

(Continued on Opposite Page)

## ENGINEER PRESIDENT



WILLIAM WALLACE MOORE

William Wallace Moore, new president of the Structural Engineers Association of Northern California, is a partner in the nationally-known engineering firm of Dames & Moore, with offices in San Francisco, Los Angeles, and San Diego.

The firm achieved national recognition for their work in Saudi Arabia, where they made investigations and reports for the Arabian American Oil Company later used by the company in constructing the foundations of its new refinery.

Moore, formerly first vice-president of the SEA of Northern California, was born in Los Angeles and is the son of the well-known Southern California civil engineer, Leon W. Moore.

He is a graduate of the California Institute of Technology and served for one year in seismological observations for the U. S. Coast and Geodetic Survey under Franklin P. Ulrich. He then worked on foundations for the Labarre Company of Los Angeles, after which the firm of Dames & Moore was formed, with his classmate Trent L. Dames, as co-partner.

His avocations outside of business hours include boating, radio, photography and motion pictures. He lives in San Francisco with his wife and three children, two sons and a daughter.

ARCHITECT AND ENGINEER

**FOR BETTER SERVICE**  
*Remember that*  
**KRAFTILE is**  
**WESTERN HEADQUARTERS**  
**FOR**

- ▶ ACID Brick
- ▶ ACID-PROOF Jointing Compounds
- ▶ ACID-PROOF Floor and Tank Construction
- ▶ ACID-PROOF Coatings
- ▶ GLAZED Structural Wall Units
- ▶ PATIO Tile
- ▶ QUARRY Tile
- ▶ SWIMMING POOL Overflow Gutter



- ▶ QUONSET Packaged Steel Buildings
- ▶ STRAN-STEEL Framing

For complete information and prompt service, phone or write

**KRAFTILE COMPANY**

NILES, CALIFORNIA NILES 3611

SAN FRANCISCO: 50 Hawthorne Street — DOUGLAS 3780

LOS ANGELES: 316 E. Commercial Street — MUTUAL 2411

## STRUCTURAL ENGINEERS — cont'd

codes for San Francisco and Oakland and for improved engineering regulations brought members into periodic contact with national, state and local officials, and also with Chambers of Commerce. In addition, the association joined the San Francisco Engineering Council.

An additional Geodetic Survey was requested in a letter to former Secretary of Commerce Wallace as part of a program to better prepare the West Coast for possible earthquake disturbances. The saving of life and property was the prime consideration in this regard.

In this connection, it was recommended that the State Fire Marshal follow the 1940 Uniform Building Code in public school construction.

Other measures initiated under the guidance of President Adrian include: resumption of SEA Convention, the first in five years, attended by 75 members; preparation of a proposed schedule of fees, tentatively accepted by the directors; the setting up of a legislative committee to study proposed legislation affecting civil and structural engineers; a recommendation to universities that they enlarge the curriculum of structural engineering students; and the establishment of a service at the association's office to assist members in their problems.

\* \* \*

NEW MEMBERS include O. B. Christensen, J. H. Dunn, R. E. Gauthier, G. E. Goodall, R. F. Lovejoy, E. S. Thayer, Ray L. Walker, and Arthur M. Sevey, an Affiliate.

### CIVIL ENGINEERS MEET

The San Francisco Section of the American Society of Civil Engineers met recently and heard an address by H. J. Brunner, ASCE, past president of the San Francisco Section. Brunner spoke on the subject "Our Place in the World."

\* \* \*

A number of meetings have been held by the Student Chapter recently. Professor T. Y. Lin, recently returned from China, was a guest at one meeting and spoke on "The Future of Civil Engineering in China," and Charles H. Lee's topic was "Sewage Pollution of the San Francisco Bay," on another occasion.

Other meeting speakers included Frederick W. Panhorst, Bridge Engineer, State Department of Highways, who spoke on "The Report of the Second Bay Bridge," and William R. Seeger, whose subject was, "Public Speaking, Its Importance to Civil Engineers."

\* \* \*

### NEW MEMBERS

Harold B. Gotaas was recently received as a

# Plan for built-in telephone outlets

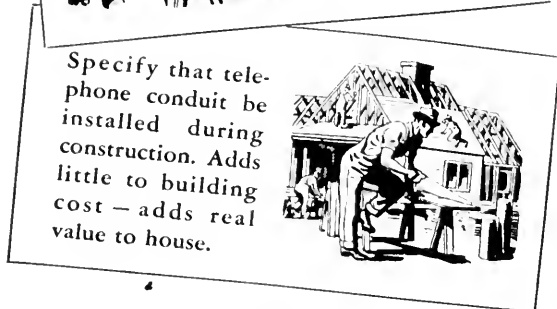
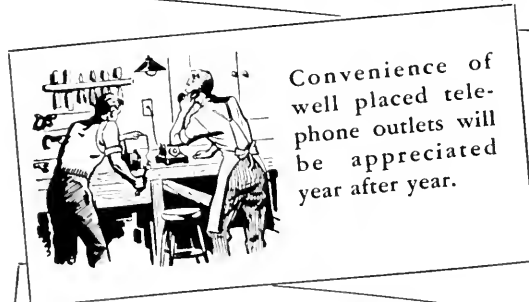
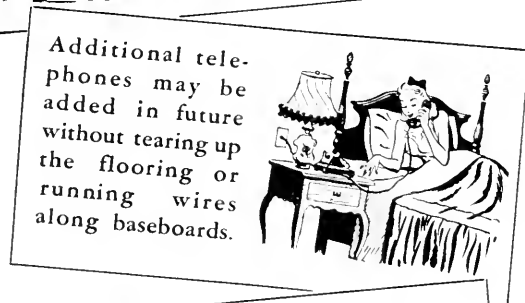
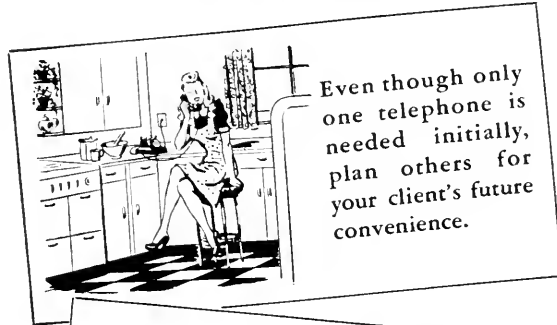

Call your local Telephone Business Office.  
Ask for free Architects' and Builders' Service.

## The Pacific Telephone and Telegraph Co.



**A Name\*  
to Know  
for Efficiency  
and Economy  
in ROOF TRUSSES**



For sound, efficient roof truss engineering and construction, Builders and Architects in the East and Mid-West know and rely upon American. Now yours to command throughout the Far West, are American's quarter-century background and complete facilities.

When you write or phone concerning your roof truss job, state load, length of span, number required, spacing. Let us submit you an estimate - today!

**REGISTER YOUR NAME** now for new catalog and stress data - soon off the press.



**AMERICAN ROOF TRUSSES**

228 West Santa Barbara Avenue  
Los Angeles, California  
ADams 1-4379

**CIVIL ENGINEERS — cont'd**

member, and C. R. Graff, Emil J. Kaleschke, Dick G. Pepin, and John K. Vennard as associated members.

New junior members include: James E. Arntson, G. B. Childers, Verne Cooperrider, Walter R. Hogue, C. M. Jones, M. A. Liston, Laurence W. Milnes, Herbert A. Navis, Fred Pavlow, Jack W. Pierce, Karl S. Pister, Jay Scheinman, James E. Schumann, Francis J. Sitek, George R. Thenn, Jr., and K. R. Wyatt.

Ingwald Edward Flaa, Hydraulic Engineer of the San Francisco Water Dept., retired from the city's service recently after 37 years on the water supply of the city . . . Harold Enderlin has established a Sacramento headquarters for the U. S. Soil Conservation Service.

**HEATING AND VENTILATING ENGINEERS MEET**

The Southern California Chapter of the American Society of Heating and Ventilating Engineers met recently in Los Angeles.

Ferdinand Jehle, chief engineer of the Hoffman Specialty Company of Indianapolis, spoke on "Panel Heating."

**MECHANICAL ENGINEERS MEET**

Given Brewer, consulting engineer, of Laguna Beach, and H. O. Fuchs, project engineer of Los Angeles, spoke before a recent meeting of the Southern California Section of the American Society of Mechanical Engineers held at the Roger Young Auditorium in Los Angeles.

Brewer's subject was: "The Photogrid Process." This is a process of photographing reference lines on metal which is to be worked, the purpose being to study the flow of metal during forming.

Fuchs spoke on the "Influence of Residual Stresses on Fatigue Life."

**CIVIL ENGINEERS MEET . . . L. A. SECTION**

A dinner meeting of the American Society of Civil Engineers, Los Angeles Section, was held recently at the Rodger Young Auditorium.

R. McC. Beanfield, Los Angeles consulting engineer, spoke on "Construction Features of Underground Field Storage Reservoirs at Pearl Harbor." Beanfield was in charge of the project while on duty as an army colonel.

**NEW PRESIDENT FOR CIVIL ENGINEERS**

Edgar M. Hastings, of Richmond, Va., Chief Engineer of the Richmond, Fredericksburg and Potomac Railroad Company, was nominated as the 1947 President of the American Society of Civil



Engineers at the Fall Meeting of the Society's Board of Direction recently held in Kansas City.

Since the nomination is tantamount to election, Mr. Hastings will taken office at the society's annual meeting in New York in January.

Hastings' entire professional life has been in the field of railroad engineering. He has been associated with the RF&P since 1903, and has been chief engineer since 1922.

#### **APPOINTED RESEARCH LABORATORY DIRECTOR FOR U. S. STEEL**

Dr. J. B. Austin has been named Director of the Research Laboratory of United States Steel Corporation, succeeding Dr. John Johnston, retired.

Dr. Johnston founded the research laboratory at Kearny, New Jersey, in 1928, with a small staff. Today the laboratory employs some fifty-seven scientists, while several thousand are engaged in research in laboratories of U. S. Steel subsidiaries.

#### **AIR DISTRIBUTION**

(Continued from Page 15)

000 cfm of air is handled at air-duct velocities varying from 900 to 1200 feet per minute. Yet, after air leaves the Anemostats, velocity readings taken at the occupancy levels of rooms do not exceed 40 feet per minute—or less than one-half mile per hour!

Obviously, small ducts carrying high-velocity air will furnish the same volume of air as larger ducts carrying low-velocity air. Since these efficient air-diffusers circulate air of the highest duct velocities in a draftless, low-velocity pattern, they made it possible to install smaller ducts to handle larger volumes of air. Duct layouts also may be simplified because efficient air-diffusers distribute the air uniformly in spite of columns, machines, and other obstacles.

Architects and engineers find that small ducts and the simplification of duct layouts greatly facilitate their work when altering existing construction to accommodate air-conditioning, and when planning new construction. They have also found that the appearance of the Anemostat makes it desirable in stores, restaurants, public buildings, homes, and other installations where interiors must be especially attractive.

Virtually all architects and engineers will eventually be called upon to include air-conditioning in some of their plans, for surveys indicate that the air-conditioning field will be a billion dollar industry within ten years. In such planning it will be well for them to remember that no air-conditioning system can be better than its air-distribution.

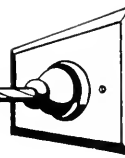

## **Let's Talk Wiring**

The growth in the use of electricity in the home has been steady and amazing. But, average wiring capacity has never quite been able to catch up, and few homes have truly enjoyed the most efficient and convenient use of appliances and lighting equipment.

Now, as we are about to begin a new era in building, there is an opportunity to "start from scratch"—to provide complete electrical adequacy for homes of the future.

These homes, from year to year, will demand an ever expanding list of appliances — appliances which can provide satisfactory and economical service, *only* if the wiring system is adequate for the job.

Make sure each house you plan will be modern, electrically, for years to come by specifying:

1. *Wiring of sufficient size;*
2. *Enough convenience outlets for future appliances and lighting needs,*
- and 3. *Enough circuits to distribute the electrical load properly.*

### **NORTHERN CALIFORNIA ELECTRICAL BUREAU**

**1355 MARKET STREET  
SAN FRANCISCO 3**

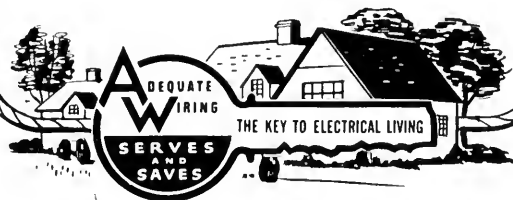



**PRESSURE TREATED LUMBER**  
**● PROTECTS AGAINST DECAY**  
**AND TERMITE ATTACK**

*Specify it in your home*  
*Available through Lumber Dealers*

LOS ANGELES  
 601 W. 5th Street  
 Phone Michigan 6294

SAN FRANCISCO  
 333 Montgomery Street  
 Phone DOuglas 3883

*J. H. Baxter & Co.*

AGENTS FOR WEST COAST WOOD PRESERVING CO. SEATTLE, WASH.



**LOS ANGELES**

Branch Offices

HOLLYWOOD  
 PASADENA  
 LONG BEACH  
 RIVERSIDE

SIERRA MADRE  
 TEMPLE CITY  
 WHITTIER  
 ONTARIO

UPLAND  
 LA VERNE  
 SAN PEDRO  
 INDIO

**OAKLAND**  
**SAN FRANCISCO**

## HEADLINE NEWS & VIEWS

By E. H. W.

"The world and the nation are at a critical juncture in history, and the engineer, that unique synthesis of the theoretical and the practical that is so badly needed, must accept his responsibility in public life and office."—Carl Hinshaw, Engineer and California Congressman.

\* \* \*

Advocates of "full employment" and "maximum security," a la various "isms," should bear in mind that any good penitentiary provides full employment and the maximum of security to its inmates.

\* \* \*

Declaring the California State Housing Act "has become obsolete" a Joint Sub-Committee representing the Construction Industry has prepared numerous "changes" for consideration during the current session of the California Legislature.

\* \* \*

Discrepancy in freight rates between "Eastern" and "Inter-Mountain" points of origin and the Pacific Coast are emphasized in a report of the State of Utah. Western industry has a tough nut to crack in this instance.

\* \* \*

If the charges of Norton E. Long, former deputy housing expediter, are true—that the Federal housing program is dead,—immediate steps should be taken by State Legislative action to "protect the public" from further activities of war-spawned governmental agencies.

\* \* \*

Removal of many Federal restrictions on the "construction industry" should be augmented by Legislative action eliminating the present policy of the State of California engaging in the practice of Architecture. Private enterprise can not be successfully conducted in competition with government—local, state, or national.

\* \* \*

Architects and engineers are completing work on national plans and specifications for an industry-engineered housing program designed to bring substantial savings in building costs, according to a recent announcement by Tyler S. Rogers, president of the Producers' Council.

\* \* \*

The latter part of 1946 saw individual incomes reaching a new high although some manufacturers wage classifications were down due to strikes.

## IN THE NEWS

### FIRST CHOICE

Veterans families about to be evicted will get the first chance at vacancies in war and permanent housing projects, the San Francisco Housing Commission has ruled.

### DRAFT ELIMINATING DOOR SEAL AVAILABLE

Needs no expert mechanic as anyone can install in few minutes. Saves fuel, seals doors against drafts, dust, noise, odors, light, insects, and is of all metal construction with moulded rubber sealing plate.

Seals and adjusts itself to any size opening under door up to 1 1/4".



The "DRAFT-BLOC", manufactured by V & L HOME UTILITIES CORP'N, Rockford, Illinois, is completely automatic, and self adjusting, works either right or left hand swing fits all standard doors.

### ELECTED PRESIDENT S. F. CHAMBER OF COMMERCE

Carl J. Eastman, vice president and Pacific Coast manager of N. W. Ayer & Son, Inc., internationally known advertising agency, has been elected president of the San Francisco Chamber of Commerce.

Active in the advertising field for the past 21 years, Eastman is well known on the Pacific Coast, having been in the agency business here since 1925.

**KOBICK & FOSTER**, Architects, have moved into larger offices at 726 1/2 K Street, Sacramento 14, California.



Available with or without hanger. Uses four 40 W. fluorescent lamps.

## PLASCOLIER

A new shielded luminaire that is now in production by Smoot-Holman. Extremely efficient, combining minimum surface brightness, maximum diffusion, low absorption. Lightweight plastic diffuser is safe to handle, no breakage hazards. Write for Catalog



Offices in Principal Western Cities—Branch and Warehouse in San Francisco

# PRODUCER'S COUNCIL PAGE

The National Organization of Manufacturers of Quality Building Materials and Equipment  
affiliated with THE AMERICAN INSTITUTE OF ARCHITECTS

President, E. E. CATHCART  
Johns-Manville Sales Corp.  
116 New Montgomery St.

Vice-President, C. J. NICHOLAS  
Bostion-Morley Co.  
301 Brannon St.

Secretary, H. C. GALITZ  
Westinghouse Electric Corp.  
110 Sutter St.

Treasurer, E. P. LARSON  
Celotex Corp.  
675 Townsend St.

Edited by C. W. KRAFT, KRAFTILE CO., Niles, California

## NORTHERN CALIFORNIA CHAPTER



B. F. Wade  
California Redwood Assn.

"Ben" Wade was born in the "East", Golden Colorado, but educated in the West, Stanford U. He came to California in 1936 to join the staff of California Redwood Association, a new member of the Producers' Council.

He is Consulting Engineer for the association, in charge of General engineering and research work. He also

handles the Association's Technical Service Department, covering inquiries on wood technology, design and utilization for general architectural and engineering fields, and analysis of problems arising in the wood-using industries.

He is married, lives in San Francisco. He is a member of the American Society of Civil Engineers. His favorite sports are baseball and football and his hobby is gardening.

**CONGRATULATIONS** to President Ed Cathcart, Vice-President C. J. Nicholas, Secretary Herb Galitz and Treasurer Ernie Larson on a fine chapter year just completed. Attendance throughout the year was the best yet at our monthly meetings testifying to the interesting programs presented and the worthwhile activities engaged in for the benefit of the entire construction industry. Chapter members enter upon a period of unprecedented building activity enjoying the confidence and respect of Architects and Engineers in facing the problems ahead, we are told by our good friends in the industry.

### SUMMING UP President Ed says:

"The Northern California Chapter of the Producers' Council has enjoyed a full year of interesting

and progressive activities. The Architectural and Engineering Societies have been very cooperative in making our meetings and other affairs successful. We appreciate their interest and assistance both on the part of their officers and members.



C. J. Nicholas  
New President

Our affiliation with the Building Industry and Conference Board has been most enjoyable and interesting to our members. We value our membership in this organization very highly. Being a cross section of the essential elements of the Building Industry, we have found the members very receptive to consider any

problem that affects the industry as a whole in this area. In the future we anticipate it will become even stronger and more effective.

The members of the Council have during the year been willing at all times to do their share. Their activities have made the jobs of the officers much easier and for this all the officers are very grateful."

### AND NOW the new slate of officers for 1947.

President—C. J. Nicholas, Bastian-Morley Co.  
Vice President—E. P. Larson, Celotex Corp.  
Secretary—C. E. Berry, Mueller Brass Co.  
Treasurer—J. A. Carlson, Kraftile Co.

Charles J. Nicholas brings to the office of President the experience of many years of organization work in which he has served the Chapter in many capacities including Vice-President and Secretary.

"Nick" is Northern California Manager for Bastian-Morley Company.

(Continued on Next Page)

USE QUALITY PRODUCTS



CONSULT AN ARCHITECT

**MODULAR COORDINATION** really began to snow-ball in '46. That it is an accepted fact throughout much of the construction industry is evidenced by the flood of manufacturers' literature, too numerous to list here, describing and detailing modular coordinated products.

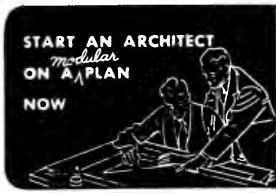

**PRODUCERS COUNCIL AIDS U. S. C. LECTURE PROGRAM**

The Southern California Chapter of the Producers Council will aid the faculty of the University of Southern California College of Architecture in the devising of new, practical techniques of training.

Representatives of member companies were assigned the preparation and presentation of a series of lectures. These lectures are to be based on the historical background of the material or product, the raw materials used, and the processes of manufacture.

**ESTABLISHMENT** of a joint cooperative committee between the National Association of State Aviation Officials and The Associated General Contractors of America has been agreed upon by the organizations.

**PRODUCERS COUNCIL HOLD PARTY**

The annual Christmas party of the Producers' Council, Southern California Chapter, was held at the Elks Club, Los Angeles.

**CLAY PIPE OUTPUT**

The nation's clay pipe manufacturing industry is turning out approximately 8,800,000 feet of four and six inch vitrified clay pipe per month, according to recent reports of the National Clay Pipe Manufacturers, Inc.

At the average installation of 40 feet this provides for almost a quarter of a million homes for veterans and other needy home seekers every month. At this rate 3,000,000 new homes will be provided for annually.

**APPOINTED ENGINEER**

Irving C. Harris has been appointed construction engineer at Shasta Dam, according to a recent U. S. Bureau of Reclamation announcement.

Harris was formerly acting construction engineer and will be in charge of all work at Shasta and Keswick dams, and on the Oroville-Sacramento transmission line.

**BASALITE**  
 LIGHTWEIGHT CONCRETE  
 BUILDING UNITS

---

CHARACTER • ECONOMY • INSULATION  
 FIRE-SAFE • TERMITE PROOF • PERMANENCE

---

**BASALT ROCK CO., INC.**  
 NAPA, CALIFORNIA

**FORDERER CORNICE WORKS**  
*Manufacturers of*  
 Hollow Metal Products • Interior Metal Trim  
 Elevator Fronts and Cabs  
 Metal Plaster Accessories • Sanitary Metal Base  
 Flat and Roll Metal Screens  
 Metal Cabinets • Commercial Refrigerators

---

**269 POTRERO AVE.**  
 SAN FRANCISCO, CALIF.      HEMLOCK 4100

**STRUCTURAL STEEL**  
 For Class A Buildings,  
 Bridges, etc.

**JUDSON PACIFIC - MURPHY CORP.**  
 1200 SEVENTEENTH STREET  
 SAN FRANCISCO

==== Plants: San Francisco - Oakland ====

**SISALKRAFT**  
 REG. U. S. PAT. OFF.

*"More than a building paper"*

**THE SISALKRAFT CO.**  
 205 West Wacker Drive  
 Chicago, Ill.  
 55 New Montgomery Street  
 San Francisco, Calif.

## A.I.A. ACTIVITIES

(Continued from Page 31)

Plans submitted by entrants that have been approved will be turned over to the Small House Plans Bureau of the Washington State Chapter of A.I.A., who will in turn arrange to have the plans displayed for public selection.

The panel of jurors judging the entries includes Mayor William F. Devin of Seattle. Assisting him will be: M. H. Gregerson, Chairman, Seattle Veterans' Housing Center Operating Committee; Dean A. P. Herman, School of Architecture, University of Washington; E. E. McLaughlin, Chief Underwriter, Federal Housing Administration; Dorothy Neighbors, Seattle Times; Pietro Belluschi, architect, A.I.A., Portland, Oregon; and Paul Kirk, architect, A.I.A., Seattle, Wash.

A discussion of the Principles of Professional Practice featured a recent meeting of the Chapter, with A. M. Young, Architect, acting as chairman.

Young reviewed the growth of the American Institute of Architects from its inception eighty-nine years ago to the present. He pointed out the difficulties faced by the architectural profession in evolving principles and practices acceptable to the profession as a whole when there were no precedents to follow.

## VALUABLE NEWS SERVICE

- BUILDING MATERIAL DEALERS
- CONTRACTORS
- ENGINEERS
- FINANCIAL INSTITUTIONS

**ARCHITECTS REPORTS** gives advance news on construction projects in Northern California, lists: name of projects, location, architect, proposed cost and other pertinent information.

**HANDY** individual slip-reports, issued daily at a total cost of only

\$10 a month

## ARCHITECT'S REPORTS

Published Daily

The ARCHITECT and ENGINEER, Inc.

68 Post Street, San Francisco - DO 8311

## Re-Development Committee Formed

The Chapter voted to form a committee to work with a committee from the Seattle Chamber of Commerce in the development of a proposed new urban re-development bill.

## Initiation of New Members Revived

George W. Stoddard, Architect, Chapter president, announced that the Board has approved the revival of the initiation ceremony of new members. The practice was abandoned during the period of little activity when few members were taken in.

All members accepted since January 1, 1946, will be initiated in marking the revival of the tradition.

## New Members Received

John L. Rogers, Lawrence G. Waldon, Philip R. Moore, John I. Mattson, Walter Rothe, Frederick Ahlson, Harry Broman, and Ivan Meyer, all architects, were received as Corporate Members of the Chapter.

Accepted as Associate Members were: A. E. Hennesy, Haymond Peck, John Lindhahl, John M. Morse, Redmond Stout, Roland G. Pray, Ernest Weber, Marshall Perrow, and Ross Copeland.

The labor shortage in the Washington State area was discussed and it was pointed out that there is not enough labor available now to handle the materials on hand. An increase in the apprenticeship program was suggested as a means of increasing the number of skilled artisans.

## WOMEN'S ARCHITECTURAL LEAGUE SAN FRANCISCO SECTION

Newly certificated Architects and their wives were guests at a dinner party given in their honor by the Women's Architectural League of San Francisco and the Northern California Chapter, A. I. A., in San Francisco on November 21st.

Andrew P. Hass, President, Northern California Chapter, A. I. A., spoke following the dinner.

Ruth Gerth Kosmak, chairman of arrangements, was assisted by Mrs. Norman Blanchard, Mrs. Ernest Born, Mrs. Mario Corbett, Mrs. William Hempel, Mrs. Irwin Johnson, Mrs. J. Kingsford Jones, Mrs. F. Joseph McCarthy, Mrs. Joseph Allen Stein, and Mrs. Chester Treichel.

## CENTRAL COAST COUNTIES ASSOCIATION OF ARCHITECTS

Consideration of a proposal to become a Chapter of the A. I. A., under the national program now in effect in California, was the principal topic of business at a recent meeting held in Monterey.

Invitations were extended for members to attend a meeting of the Central Valley Chapter, A. I. A., in Stockton and hear a talk on the State Housing Act by Adrian Wilson.

# ESTIMATOR'S GUIDE

## BUILDING AND CONSTRUCTION MATERIALS

PRICES GIVEN ARE FIGURING PRICES AND ARE MADE UP FROM AVERAGE QUOTATIONS FURNISHED BY MATERIAL HOUSES TO SAN FRANCISCO CONTRACTORS. 2½% SALES TAX ON ALL MATERIALS BUT NOT LABOR

All prices and wages quoted are for San Francisco and the Bay District. There may be slight fluctuation of prices in the interior and southern part of the state. Freight cartage, at least, must be added in figuring country work.

**BONDS**—Performance—\$10 per \$1000 of contract. Labor and materials, \$10 per \$1000 of contract.

**BRICKWORK**—

- Common Brick—Per 1M laid—\$100.00. (according to class of work).
- Face Brick—Per 1M laid—\$120 to \$150 (according to class of work.)
- Brick Steps—\$1.60 per lin. ft.
- Brick Veneer on Frame Bldg.—Approx. \$1.30 per sq. ft.
- Common Brick—\$26.00 per M, truckload lots, f.o.b. job.
- Face Brick—\$40 to \$80 per M, truckload lots, delivered.
- Cartage—Approx. \$4.00 per M.

**BUILDING PAPER**—

1 ply per 1000 ft. roll.....	\$4.25
2 ply per 1000 ft. roll.....	6.25
3 ply per 1000 ft. roll.....	7.75
Brownskin, Standard, 500 ft. roll.....	6.00

**BUILDING HARDWARE**—

- Sash cord com. No. 7.....\$1.20 per 100 ft.
- Sash cord com. No. 8.....1.50 per 100 ft.
- Sash cord spot No. 7.....1.90 per 100 ft.
- Sash cord spot No. 8.....2.25 per 100 ft.
- Sash weights, cast iron, \$50.00 ton.
- Nails, \$3.42 base.
- Sash weights, \$45.00 per ton.

**CONCRETE AGGREGATES**—

The following prices net to Contractors unless otherwise shown. Carload lots only.

	At S.P. Yard, S.F.	Del'd per ton
Gravel, all sizes.....	\$1.46	\$2.15
Top Sand.....	1.56	2.25
Concrete Mix.....	1.51	2.20
Crushed Rock, ¼" to ¾".....	1.56	2.35

Crushed Rock, ¾" to 1½".....	1.90	2.50
Roofing Gravel.....	2.25	2.80
River Sand.....	2.00	2.45

**Sand**—

Lapis (Nos. 2 & 4).....	1.76	2.80
Olympia (Nos. 1 & 2).....	1.65	2.40

**Cement**—

Common (all brands, paper sacks), carload lots, \$2.42 per bbl. f.o.b. car; delivered \$2.72. Cash discount on carload lots, 10c a bbl., 10th Prox.; less than carload lots \$3.20 per bbl. f.o.b. warehouse or delivered.

Cash discount 2% on L.C.L.

Atlas White }  
Calaveras White } 1 to 100 sacks, \$2.50 sack  
Medusa White } warehouse or del.; \$7.65  
                  } bbl. carload lots.

Forms labor average \$350 per 1000 sq. feet. Average cost of concrete in place, 50c per cubic foot, exclusive of forms; \$15.00 per cubic yard. With forms \$1.60 per cubic foot.

**DAMP-PROOFING and Waterproofing**—

- Two-coat work, \$3.50 per square.
- Membrane waterproofing—4 layers of saturated felt, \$7.00 per square.
- Hot coating work, \$2.50 per square.
- Medusa Waterproofing, \$3.50 per lb. San Francisco Warehouse.
- Tricocel waterproofing.  
(See representative.)

**ELECTRIC WIRING**—\$12 to \$15 per outlet for conduit work (including switches).

Knob and tube average \$3.00 per outlet. (Available only for priority work.)

**ELEVATORS**—

Prices vary according to capacity, speed and type. Consult elevator companies. Average cost of installing a slow speed automatic passenger elevator in small four story apartment building, including entrance doors, about \$6500.00.

**EXCAVATION**—

Sand, 60 cents; clay or shale \$1 per yard.

Trucks, \$20 to \$32 per day.

Above figures are an average without water. Steam shovel work in large quantities, less; hard material, such as rock, will run considerably more.

**FIRE ESCAPES**—

Ten-foot galvanized iron balcony, with stairs, \$150 installed on new buildings; \$160 on old buildings.

**FLOORS**—

- Composition Floors, such as Magnesite, 50c per square foot.
- Linoflor—2 gages—\$1.25 to \$2.75 per sq. yd.
- Mastipave—90c to \$1.50 per sq. yd.
- Battleship Linoleum—available to Army and Navy only—1/8"—\$1.75 sq. yd. 3/8"—\$2.00 sq. yd.
- Terazzo Floors—50c to 70c per sq. ft.
- Terazzo Steps—\$1.75 per lin. ft.
- Mastic Wear Coat—according to type—20c to 35c.
- Hardwood Flooring—Standard Mill grades not available.
- Victory Oak—T & G  
1 1/2" x 2 1/4".....\$275.00 per M. plus Cartage  
1 1/2" x 2".....Not Available  
1 1/2" x 1 1/2".....Not Available
- Prefinished Standard & Better Oak Flooring  
1 1/2" x 3/4".....\$180.00 per M. plus Cartage  
1 1/2" x 2 1/2".....160.50 per M. plus Cartage
- Maple Flooring  
1 1/2" T & G Clear \$160.50 per M. plus Ctg.  
2nd 153.50 per M. plus Ctg.  
3rd 131.25 per M. plus Ctg.
- Floor Layers' Wage, \$1.87½ per hr. (Legal as of Jan. 21, 1946. Given us by Inlaid Floor Co.)

**GLASS**—

Single Strength Window Glass.....	\$.25 per □ ft.
Double Strength Window Glass.....	.35 per □ ft.
Plate Glass, under 75 sq. ft.....	1.25 per □ ft.
Polished Wire Plate Glass.....	1.95 per □ ft.
Rgh. Wire Glass.....	.44 per □ ft.
Obscure Glass.....	.35 per □ ft.
Glazing of above is additional.	
Glass Blocks.....	\$2.50 per □ ft. set in place

**HEATING**—

- Average, \$1.90 per sq. ft. of radiation, according to conditions.
- Warm air (gravity) average \$64 per register.
- Forced air, average \$91 per register.

## INSULATION AND WALLBOARD

Rigid Insulation—Full thickness	\$79.00 per M sq. ft.
Asbestos Insulation—Full thickness	\$95.50 per M sq. ft.
Asbestos Insulation—Foil-mounted	\$33.50 per M sq. ft.
Wallboard—4'x6' panel	\$9.00 per panel
Wallboard—5' thickness	\$49.50 per M sq. ft.
Finished Plank	\$69.00 per M sq. ft.
Cement Tileboard	\$69.00 per M sq. ft.

**IRON**—Cost of ornamental iron, cast iron, etc., depends on design.

**LUMBER**—No more "on grade" lumber—all sold unsorted.

Flooring—	Per M Delvd.
V.G., D.F. B & Btr. 1 x 4 T & G Flooring	\$150.00
"C" and better—all	150.00
"D" and better—all	150.00
Rwd. Rustic—"A" grade, medium dry	150.00
8 to 24 ft.	
"B" grade, medium dry	150.00
Plywood	15c to 18c per ft.
Plyscord	15c per ft.
Plywall	16c per ft.
Playform	25c per ft.
Shingles (Rwd. not available)—	
Red Cedar No. 1—\$13.00 per square; No. 2, \$10.50.	
Average cost to lay shingles, \$6.00 per square.	
Cedar Shakes—Tapered: 1/2" to 3/4" x 25"—\$8.95 per square.	
Resawn: 3/4" to 1 1/4" x 25"—\$10.65 per square.	
Resawn: 3/4" to 1 1/4" x 25"—\$10.65 per square.	
Average cost to lay shakes, \$4.00 per square.	

## MILLWORK—Standard.

D. F. \$100 per 1000. R. W. Rustic \$100.00 per 1000 (delivered).
Double hung box window frames, average with trim \$6.50 and up, each.
Complete door unit, \$10.00.
Screen doors, \$3.50 each.
Patent screen windows, 25c a sq. ft.
Cases for kitchen pantries seven ft. high, per lineal ft., \$9.00 each.
Dining room cases, \$9.00 per lineal foot. Rough and finish about 80c per sq. ft.
Labor—Rough carpentry, warehouse heavy framing (average), \$40.00 per M.
For smaller work average, \$40.00 to \$55.00 per 1000.

## MARBLE—(See Dealers)

## PAINTING—

Two-coat work	per yard 50c
Three-coat work	per yard 70c
Cold water painting	per yard 10c
Whitewashing	per yard 8c

## PAINTS—

Two-coat work	50c per sq. yd.
Three-coat work	70c per sq. yd.
Cold water painting	per yard 10c
Whitewashing	8c per sq. yd.
Turpentine	\$1.85 per gal. in 5-gal. cont.
Raw Linseed Oil	\$3.19 per gal. in 5-gal. cont.

Boiled Linseed Oil—\$3.25 per gal. in 5-gal. containers.

Replacement Oil—\$2.53 per gal. in drums. \$2.63 per gal. in 5-gal. containers.

A deposit of \$6.00 required on all drums.

## PATENT CHIMNEYS—

6-inch	\$1.20 lineal foot
8-inch	1.40 lineal foot
10-inch	2.15 lineal foot
12-inch	2.75 lineal foot

## PLASTER—

Neat wall, per ton delivered in S. F. in paper bags, \$17.60.

## PLASTERING (Interior)—

3 Coats, metal lath and plaster	Yard \$2.25
Keene cement on metal lath	2.70
Ceilings with 3/4 hot roll channels metal lath (lathed only)	1.80
Ceilings with 3/4 hot roll channels metal lath plastered	3.30
Single partition 3/4 channel lath 1 side (lath only)	1.80
Single partition 3/4 channel lath 2 inches thick plastered	4.80
4-inch double partition 3/4 channel lath 2 sides (lath only)	3.30
4-inch double partition 3/4 channel lath 2 sides plastered	5.75
Thermax single partition; 1" channels; 2 1/4" overall partition width. Plastered both sides	4.95
Thermax double partition; 1" channels; 4 3/4" overall partition width. Plastered both sides	6.60
3 coats over 1" Thermax nailed to one side wood studs or joists	2.45
3 coats over 1" Thermax suspended to one side wood studs with spring sound isolation clip	2.85
Note—Channel lath controlled by limitation orders.	

## PLASTERING (Exterior)—

2 coats cement finish, brick or concrete wall	Yard \$2.00
3 coats cement finish, No. 18 gauge wire mesh	3.00
Lime—\$4.00 per bbl. at yard.	
Processed Lime—\$4.15 per bbl. at yard.	
Rock or Grip Lath—3/8"—30c per sq. yd.	
5/8"—29c per sq. yd.	

Composition Stucco—\$2.70 to \$3.00 sq. yard (applied).

## PLUMBING—

From \$100.00 per fixture up, according to grade, quantity and runs.

## ROOFING—

"Standard" tar and gravel, 4 ply	\$8.00 per sq. for 30 sqs. or over.
Less than 30 sqs.	\$9.50 per sq.
Tile	\$30.00 to \$40.00 per square.
Redwood Shingles	\$19.00 per square in place.
5/2 # 1-16" Cedar Shingles, 4 1/2" Exposure	\$19.00 square

5/8 x 16"—# 1 Cedar Shingles, 5" Exposure	\$19.00 square
4/2 # 1-24" Royal Shingles, 7 1/2" Exposure	\$20.00 square
Re-coat with Gravel	\$4.00 per sq.
Asbestos Shingles, \$23 to \$28 per sq. laid.	
1/2 x 25" Resawn Cedar Shakes, 10" Exposure	\$12.00
3/4 x 25" Resawn Cedar Shakes, 10" Exposure	\$12.00
1 x 25" Resawn Cedar Shakes, 10" Exposure	\$25.00
Above prices are for shakes in place.	

## SHEET METAL—

Windows—Metal, \$1.75 a sq. ft.  
Fire doors (average), including hardware \$2.00 per sq. ft.

## SKYLIGHTS—(not glazed)

Copper, 90c sq. ft. (flat).  
Galvanized iron, 40c sq. ft. (flat).  
Vented hip skylights 60c sq. ft.

## STEEL—STRUCTURAL—

Base, delivered, \$3.06 per 100, plus normal extras; or \$225.00 ton in place. Light truss work higher.

## STEEL REINFORCING—

Base, \$3.01 per 100; or about \$170 ton dependent upon normal extras.

## STONE—

Granite, average, \$6.50 cu. foot in place.  
Sandstone, average Blue, \$4.00. Boise, \$3.00 sq. ft. in place.  
Indiana Limestone, \$2.80 per sq. ft. in place.

## STORE FRONTS (None available).

## TILE—

Ceramic Tile Floors—\$1.00 to \$1.25 per sq. ft.  
Cove Base—\$1.10 per lin. ft.  
Glazed Tile Wainscot—\$1.25 per sq. ft.  
Asphalt Tile Floor 1/8" x 3/8"—\$.18 to \$.35 per sq. ft. Light shades slightly higher.  
Cork Tile—\$.40 to \$.75 per sq. ft.  
Mosaic Floors—see dealers.  
Lino-Tile—\$.35 to \$.75 per sq. ft.

## Wall Tile—

Glazed Terra Cotta Wall Units (single faced) laid in place—approximate prices:  
2 x 6 x 12—\$1.10 sq. ft.  
4 x 6 x 12—1.25 sq. ft.  
2 x 8 x 16—1.20 sq. ft.  
4 x 8 x 16—1.40 sq. ft.

## VENETIAN BLINDS—

50c per square foot and up. Installation extra.

## WINDOWS—STEEL—

30c per square foot, \$5 for ventilators.



# IN THE NEWS

## BUILDING IN PACIFIC

Bids are being taken on \$40,000,000 in building materials for construction work at the U. S. Navy facility at Guam, in the Marianas, authorized by the U. S. Bureau of Yards & Docks, Navy Dept., Washington, D. C.

The architects on the project are the Pacific Islands Engineers, consisting of Blanchard & Maher, Keller & Gannon, and Frederick R. Harris, of the Ferry Building, San Francisco.

General contractors are Brown-Pacific-Maxon, of San Francisco.

Bids are also being taken on building materials for a new Army camp and air base at Okinawa, cost not stated. The project is being undertaken by the U. S. Government War Dept., Washington, D. C.

Holmes, Narver & Kruger, at Marinship Yard, Sausalito, are the engineers, and Guy F. Atkinson

Company and the J. A. Jones Construction Company, of Sausalito, are general contractors.

ELLISON & KING, Engineers, have opened new offices at 1045 Sansome Street, San Francisco 11, California.

## TO HEAD WEST COAST OFFICE

Edward L. Barnes, architect, now heads the West Coast office of the industrial designing organization of Henry Dreyfuss, it was announced recently. The office is in Pasadena.

Barnes was formerly connected with the late Timothy Pflueger and with William Wilson Wurstler of San Francisco.

## ANNUAL MEETING

After a lapse of five years the Chamber of Commerce of the United States will hold its next annual meeting in Washington, D. C., on April 29, 30, and May 1, 1947.

It will be the thirty-fifth meeting of the organization.

## BUILDING TRADES WAGE (JOB SITES) NORTHERN AND CENTRAL CALIFORNIA

ATTENTION: The following are the PREVAILING hourly rates of compensation as determined by the Wage Adjustment Board, or which have been determined by the United States Department of Labor—Revised to July 1, 1946. Wage scales shown are those being paid and in effect mostly by agreement between employees and their union.

	San Francisco	Alameda and Contra Costa	Marin	Vallejo	San Mateo	San Jose	Stockton	Sacramento	Fresno
	<b>CRAFT</b>								
ASBESTOS WORKERS.....	1.75	1.75	1.75	1.75	1.75	1.75	1.75	1.75	1.75
BRICKLAYERS.....	2.05	2.05	2.05	2.05	2.05	2.05	1.75	2.05	2.00
BRICKLAYERS, HODCARRIERS.....	1.57½	1.57½	1.57½	1.57½	1.57½	1.57½	1.47½	1.15	1.25
CARPENTERS.....	1.75	1.75	1.75	1.75	1.75	1.62½	1.50	1.50	1.50
CEMENT FINISHERS.....	1.75	1.75	1.75	1.75	1.75	1.75	1.75	1.75	1.75
ELECTRICIANS.....	1.87½	1.87½	1.87½	1.70	1.87½	1.87½	1.75	1.82½	1.75
ENGINEERS: MATERIAL HOIST.....	1.60	1.60	1.60	1.60	1.60	1.60	1.60	1.60	1.60
PILE DRIVER.....	2.00	2.00	2.00	2.00	2.00	2.00	2.00	2.00	2.00
STRUCTURAL STEEL.....	2.00	2.00	2.00	2.00	2.00	2.00	2.00	2.00	2.00
GLASS WORKERS.....	1.58½	1.58½	1.58½	1.58½	1.58½	1.21	1.40	1.37½	1.37½
IRONWORKERS: ORNAMENTAL.....	1.85	1.85	1.85	1.85	1.85	1.85	1.85	1.85	1.85
REINF. RODMEN.....	1.75	1.75	1.75	1.75	1.75	1.75	1.75	1.75	1.75
STRUCTURAL.....	2.00	2.00	2.00	2.00	2.00	2.00	2.00	2.00	2.00
LABORERS: BUILDING & CONCRETE.....	1.25	1.25	1.15	1.15	1.15	1.15	1.25	1.25	1.15
LATHERS.....	1.90	1.90	1.60	1.87½	1.75	2.00	1.87½	1.60	1.87½
MARBLE SETTERS.....	1.75	1.75	1.75	1.75	1.75	1.75	1.75	1.75	1.75
MOSAIC & TERRAZZO.....	1.75	1.75	1.75	1.75	1.75	1.75	1.60	1.16	1.12½
PAINTERS.....	1.75	1.75	1.75	1.64	1.75	1.75	1.60	1.60	1.50
PILEDRIVERS.....	1.86	1.86	1.86	1.86	1.86	1.86	1.86	1.86	1.86
PLASTERERS.....	2.00	2.00	1.75	2.00	2.05	2.00	2.00	1.87½	1.87½
PLASTERERS' HODCARRIERS.....	1.75	1.75	1.75	1.75	1.75	1.75	1.65	1.65	1.40
PLUMBERS.....	1.87½	1.87½	1.87½	1.87½	1.87½	1.87½	1.87½	1.87½	1.87½
ROOFERS.....	1.50	1.62½	1.50	1.62½	1.25	1.37½	1.50	1.50	1.50
SHEET METAL WORKERS.....	1.75	1.75	1.75	1.75	1.75	1.75	1.75	1.75	1.75
SPRINKLER FITTERS.....	1.58	1.58	1.58	1.58	1.58	1.58	1.58	1.58	1.58
STEAMFITTERS.....	1.87½	1.87½	1.87½	1.87½	1.87½	1.87½	1.87½	1.87½	1.87½
STONESETTERS (MASON'S).....	2.05	2.05	2.05	2.05	2.05	2.05	1.75	2.05	2.00
TILESETTERS.....	1.80	1.75	1.75	1.75	1.75	1.75	1.37½	1.37½	1.37½

Prepared and compiled by  
CENTRAL CALIFORNIA CHAPTER, ASSOCIATED GENERAL CONTRACTORS OF AMERICA  
with the assistance and cooperation of secretaries of General Contractors Associations and Builders Exchanges of Northern California.

# CLASSIFIED ADVERTISING

RATE: 10c PER WORD . . . CASH WITH ORDER

MINIMUM \$2.50

**ARCHITECT'S REPORTS**—A valuable advance news service giving building and construction information daily on projects in Northern California. Name, location, architect, proposed cost, etc., on individual slips. Ideal for securing new business leads. Hundreds of items, total monthly cost only \$10. Don't delay, subscribe today. ARCHITECT & ENGINEER, Room 618, 68 Post Street,

San Francisco, California. Phone DOuglas 8311.

**PHOTOGRAPHY**—Keep a pictorial record of your building, or construction project. Pictures are of tremendous value to contractors, builders, engineers, architects. For Industrial-Publicity-Aerial photography, see FRED MAE, Room 721-22 Hearst Bldg., San Francisco 3, California.

**ENGRAVING**—Good engravings are essential to a satisfactory job of printing reproduction. For the best, see Poor Richard Photo Engraving Co., 324 Commercial St., San Francisco.

**METAL WINDOWS** (Steel - Aluminum-Bronze). Large Stock, ALL TYPES, STEEL SASH SALES & SERVICE, Weehawken, N. J.

# IN THE NEWS

## QUONSET SALES INCREASE

Quonset factory-fabricated steel structures, famed for their war service, have become a permanent part of the American construction firmament, according to C. W. Kraft, president of the Kraftile Company, of Niles, Calif., distributors of the Quonsets.

Of the 257 listed civilian uses, one finds the Quonset filling such purposes as real estate office, dairy barn, bowling alley, farm animal shed, and

washing machine factory, to name only a few.

Kraft stated that the greatest demand is for 20 and 24-foot wide Quonsets. Other obtainable widths are the 40-foot and any multiple of the 20-foot arch.

The Kraftile Company reports the sale of more than 344 buildings in the Bay Area and Northern California counties during the first 11 months of 1946.

## NEW ARCHITECTURAL MANUAL

An architectural manual containing basic information on the complete line of building materials distributed by WESTERN ASBESTOS CO., has been published and is now offered by the Company to architects of Northern California and western Nevada.

## CLINTON CONSTRUCTION CO. OF CALIFORNIA

**General Contractors**

923 FOLSOM STREET • SAN FRANCISCO

SUtter 3440

## HOGAN LUMBER CO.

*Wholesale and Retail*

**LUMBER**

**MILL WORK • SASH & DOORS**

*Office, Mill, Yard and Docks*

SECOND AND ALICE STREETS • OAKLAND, CALIF.

Telephone GLencourt 6861

## SANTA MARIA INN

**SANTA MARIA, CALIFORNIA**

FRANK J. McCOY, General Manager

FERNAND E. PIMENTEL, Manager

On the  
Coast  
Highway  
between  
San  
Francisco  
and  
Los  
Angeles



American  
or  
European  
Plan  
•  
Old  
English  
Tap  
Room

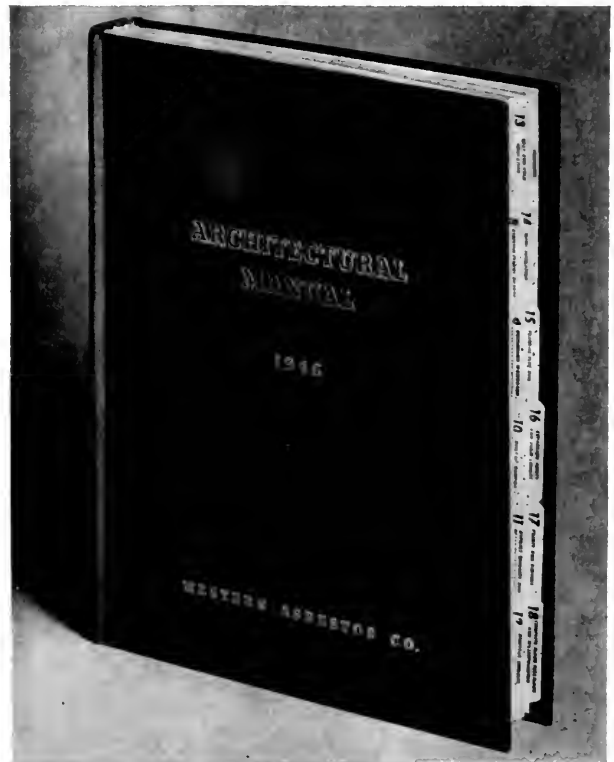

Bound in blue buckram, gold lettered, the manual is divided into sections, tabbed for ready reference, covering subjects of Acoustical Materials, Sound Conditioning, Sound Insulation, Acoustic Telephone Booths, Corrugated and Flat Transite, Building and Curing Papers, Insulation Boards, Asbestos-Cement Boards, Prefinished Wallboard and Moulding, Built-up Roofing, Asphalt Shingles and Ready-to-lay Roofing, Asbestos Shingles and Siding, Heat and Cold Insulation, Home Insulation, Transite Flue Pipe, Expansion Joints and Form Linings, Paints and Finishes and Concrete Floor Treatment and Waterproofing.

## BOOK REVIEWS PAMPHLETS AND CATALOGUES

### EXHAUST FANS FOR BUSINESS AND INDUSTRY:

**Emerson Electric Co., St. Louis 21, Mo.**

A new catalog illustrating and describing various types of EMERSON ELECTRIC EXHAUST FANS. Gives details of design, construction, specifications and performance data. Copy available upon request of manufacturer.

### CHOOSE YOUR ROOF FOR RAIN OR SHINE:

**Asphalt Roofing Industry Bureau, No. 2 W. 45th St., New York City, N. Y.**

A 24-page booklet containing many colored illustrations designed to serve as a simple guide to the selection of colors for psychological and visual effects, contrast, and harmony, according to climate, setting and style. Home planning, remodeling, and exterior design are subjects also covered.

### PANELAIRE, The Warm Air Panel Heating System:

**Sheet Metal Publication Co., 45 W. 45th St., New York 19. Price \$1.00.**

Contains an "Introduction" to Panel, or Radiant, heating with calculation, design and installation data by H. F. Randolph, vice-president, International Heater Company, Utica, N. Y. Designs, floor plans, heat loss factors, temperatures, estimating materials, suggested specifications, details of construction, and examples of plans are a few of the subjects covered in the publication.

### COLOR CONDITIONING FOR INDUSTRY: E. I.

**duPont de Nemours and Co., Wilmington 98, Delaware.**

New 32-page booklet, color illustrations, and description of years of research and practical experience.

The "Three-Dimensional Seeing" treatment of machines is depicted with photographs, and the Safety Color Code for Industry is also outlined. A coordinated functional color program for an entire plant is illustrated in a double-page cutaway drawing.

WILLIAM H. POPERT, District Engineer of the American Institute of Steel Construction, advises that the 1946 Manuals are now being mailed through the publishers. The price is \$2.00.

PACIFIC COAST AGGREGATES, San Francisco, has been named distributor in Northern California and western Nevada for DAREX AEA, according to an announcement by Charles R. Watts & Company, Seattle, distributor for the 11 Western States.

## PACIFIC MANUFACTURING CO.

HIGH CLASS INTERIOR FINISH  
QUALITY MILLWORK

142 SANSOME ST., SAN FRANCISCO  
GARfield 7755

6820 MCKINLEY AVE., LOS ANGELES  
THornwall 4196

BUILDERS EXCHANGE, OAKLAND

## "AMERICAN - MARSH"

CONDENSATION UNIT

Pumping  
Machinery  
for  
Every  
Purpose

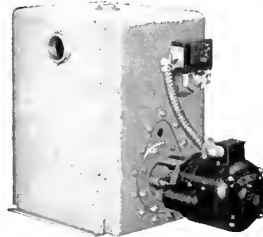

For Service  
Call

DOuglas  
6794

or  
MUtual 8322

**SIMONDS MACHINERY CO.**

SAN FRANCISCO  
816 FOLSOM

LOS ANGELES  
455 EAST 4TH

## VERMONT MARBLE COMPANY

Producers and Finishers  
of

Domestic and Imported Marbles

525 MARKET STREET, SAN FRANCISCO  
Phone SUtter 6747

727 W. 7th STREET, LOS ANGELES  
Phone TRinity 3459



The Most Complete Line of  
STEELS and BUILDING MATERIALS  
Made by a Single Producer



See Sweet's Catalog File or write us for  
full information.

**REPUBLIC STEEL CORPORATION**  
GENERAL OFFICES: CLEVELAND, OHIO

DENVER, COLORADO . . . . . CONTINENTAL OIL BUILDING  
LOS ANGELES, CALIFORNIA . . . . . EDISON BUILDING  
SALT LAKE CITY, UTAH . . . . . WALKER BANK BUILDING  
SAN FRANCISCO, CALIFORNIA . . . . . RIALTO BUILDING  
SEATTLE, WASH. . . . . WHITE-HENRY-STUART BUILDING

# IN THE NEWS

## FOOD MACHINERY EXPANDS

A CPA permit has been granted to the Food Machinery Corporation for the construction of a new factory and administration building at San Jose, to cost \$984,000. Construction will be of reinforced steel and concrete, and the general contractor is Earl W. Heple, of San Jose.

## PACIFIC T&T BUILDS

Pacific Telephone & Telegraph Co. has received a CPA permit to construct a \$100,000, 2-story structural steel frame and reinforced concrete building in Sacramento, Swinerton & Walberg, general contractors.

## NEW FAUCET PRODUCED

A new swing-type faucet is the latest addition to the "Commodore" line of plumbing fixtures manufactured by the Plumbing Division of General Tire of California.

Distinctive in appearance, this



new faucet embodies the same construction found in the ledge-type. Made from brass stampings and precision machined brass fittings, and permanently silver brazed, it combines a unit strength previously unattained in the older style faucets. The long swing spout extends 6½ inches for ample work-

ing radius over twin sinks.

A newcomer to the plumbing field, General of California is already producing 100,000 units per month, with even greater expansion contemplated. New fixtures will be added to fill out the "Commodore" line.

## MERRILL W. BAIRD, A. I. A.,

Architect, is still located in the Bank of America Building, Glendale 4, California, where he has maintained offices for the practice of Architecture for the past several years. A previous announcement of moving was in error.

## SHORTAGE "ANGLES"

On the average, 500 San Francisco families a month come to the conclusion that the best "angle" for beating the housing shortage is to buy a home and press for the eviction of the tenant, according to figures on OPA possession certifications.

## VETERAN HOUSING

The first group of emergency houses for veterans to be constructed by the City of San Francisco were ready for occupancy on the 1st of January. When completed the program will total 1200 apartments.

## STOCKTON

Moore Equipment Co., of Stockton, has been granted a CPA permit to construct a \$48,000 Quonset hut, 100'x300' of frame and stucco, with plate glass front.

## AIRPORT PLANS

Engineer William P. Day has been retained by the City of San Francisco to prepare plans for the improvement of the Municipal Airport in South San Francisco.

## SAE OFFICERS

Franklin P. Ulrich and George Arthur Sedgwick have agreed to serve as treasurer and secretary, respectively, of the Structural Engineers Association of Northern California for 1947.

## TRAFFIC RECORD

The San Francisco Bay Bridge, celebrating its tenth anniversary, has carried more traffic than any other vehicular toll structure in the United States. It has collected \$58,000,000 in tolls.

## NEW PAGLIUSO ENGINEERING COMPANY SHOWER HEAD

New shower satisfaction is obtained by use of the PECO SHOWER HEAD, recently placed on the market by the Pagliuso Engineering Company, manufacturers, of Glendale, California.

Cylindrical type head, an exclusive diffuser design with precision cut serrations gives effective spray distribution, 18" in diameter at 30" from the head. Easy to adjust, no clogging, and control mechanism is free from water contact, thus eliminating corrosion.



The PECO SHOWER HEAD is a compact unit, 3½" in length by 1½" in diameter; solid brass, designed to fit ½" N.P.T. outlets, and is easily installed.

## BUILD WAREHOUSE

A \$60,000 warehouse will be constructed at Riverbank by the Riverbank Canning Co., M. A. Little, general contractor.

*Three in One - - -*

COLD • HEAT • SOUND

PERFECTLY CONTROLLED WITH **K I M S U L**  
**INSULATION**

TREATED AGAINST FIRE, MOISTURE, VERMIN AND INSECTS. ECONOMICAL,  
LIGHT, EASY TO HANDLE AND INSTALL.

**GUNN CARLE & CO**  
20 POTRERO AVENUE • SAN FRANCISCO, CALIF.

## THE TORMEY COMPANY

GENERAL PAINTERS  
AND DECORATORS

Phone UNderhill 1913

563 FULTON STREET  
San Francisco

## IN THE NEWS

### TO BUILD FRUIT PLANT

American Fruit Growers, Inc., of Auburn, Calif., will construct a \$40,000 fruit pre-cooling plant at Auburn, C. E. Kennedy, general contractor.

### NEW PRODUCT

The new GRENBY HYGIENIC TOILET SEAT is an interesting application of the G-E Germicidal Lamp, being continuously "bathed" with germ-killing ultra-violet rays when not in use.

Entirely automatic, it requires no handling and is designed for hotels, and public places.



A Church "Moltex" Seat and a Sloan Valve are standard equipment. Edwards & Platt, 101 Park Ave., N. Y. City, have been named sales representatives.

**HOWARD P. HESS.** Architect, has moved to 312 Quimby Building, Los Angeles 14, California.

### LOSS IS GREAT

Losses in steel production for the first week in December 1946, due to the coal miners' strike, was estimated at 504,000 tons by the American Iron & Steel Institute.

This was enough steel to make 3,550,000 household refrigerators, or 200,000 automobiles.

Total loss for the year, due to strikes, was 12,350,000 tons, or about three months' shipments.



## HERRICK IRON WORKS

STRUCTURAL STEEL  
REINFORCING STEEL

18TH AND CAMPBELL STS.  
OAKLAND, CALIF.  
Phone GLencourt 1767

## ELMER F. STEIGELMAN

CIVIL ENGINEER

*Structural Design,  
Surveying and  
Subdivisions*

577 FOURTEENTH STREET  
OAKLAND, CALIFORNIA

TWinoaks: 4191

Phone GARfield 1164

## Thomas B. Hunter

*Consulting Engineer*

DESIGNER OF HEATING  
AIR CONDITIONING  
VENTILATING AND WIRING  
SYSTEMS, MECHANICAL  
AND ELECTRICAL EQUIP-  
MENT OF BUILDINGS

41 SUTTER STREET  
ROOM 710

San Francisco California

## METAL WINDOWS

Steel—Aluminum—Bronze

Large Stock—ALL TYPES

Steel Sash Sales & Service

Weehawken, N. J.

## Scott Company

HEATING - - PLUMBING - - TILE



243 MINNA STREET  
SAN FRANCISCO  
Phone EXbrook 6741

## MULLEN MFG. COMPANY

BANK, STORE AND OFFICE  
FIXTURES—CABINET WORK  
OF GUARANTEED QUALITY  
CHURCH SEATING

Office and Factory:  
60-80 RAUSCH ST., Bet. 7th and 8th Sts.  
San Francisco  
Telephone UNderhill 5815

## DINWIDDIE CONSTRUCTION COMPANY

BUILDERS

CROCKER BUILDING  
SAN FRANCISCO

## A. F. MATTOCK CO.

Builders



212 CLARA STREET  
SAN FRANCISCO

## INDEPENDENT IRON WORKS

Steel Buildings  
Service Stations  
Steel Storage Tanks  
Fabricated Plate Work  
Steel & Sheet Metal Products  
Fabricated Structural Steel  
Steel Distributors

Eighth & Pine Sts. Oakland, 7

## George F. Brayer

ELECTRICAL  
CONTRACTOR

166 Seventh Street  
San Francisco

Phone: Market 1761

## PITTSBURGH TESTING LABORATORY

Successors to  
SMITH, EMERY & COMPANY

Testing and Inspecting  
Engineers and Chemists

Structural Materials, Structures  
Equipment, Pipe, Soils.

651 Howard St., San Francisco 5  
EXbrook 1747

## Index to Advertisers

ALADDIN Heating Corp.	48
AMERICAN Roof Truss Co.	34
ARCHITECTS Reports	40
BASALT Rock Company	Back Cover
BAXTER & Company, J. H.	36
BRAYER, Geo. F.	48
CLASSIFIED Advertising	43
CLINTON Construction Company	44
DINWIDDIE Construction Company	47
FORDERER Cornice Works	39
FULLER, W. P. Co.	*
GUNN, Carle & Company	46
HANKS, Inc., Abbot A.	48
HAWS Drinking Faucet Company	1
HERRICK Iron Works	47
HOGAN Lumber Company	44
HUNT, Robert W., Company	48
HUNTER, Thos. B.	47
INDEPENDENT Iron Works	48
JUDSON, Pacific-Murphy Corp.	39
KRAFTILE Company	32
MATTOCK, A. F.	48
MULLEN Mfg. Co.	47
MUELLER Brass Co.	*
NORTHERN California Electrical Bureau	35
PACIFIC Coast Gas Association	*
PACIFIC Manufacturing Company	45
PACIFIC Portland Cement Company Inside Front Cover	
PACIFIC Telephone & Telegraph Co.	33
PITTSBURGH Testing Laboratory	48
PORTLAND Cement Association	*
REMILLARD-Dandini Co.	48
REPUBLIC Steel Corporation	45
SANTA Maria Inn	44
SCOTT Co.	47
SIMONDS Machinery Company	45
SISALKRAFT Company	39
SMOOT-Holman Co.	37
STANLEY Works, The	30
STEIGELMAN, Elmer F.	47
STEEL Sash Sales & Service	47
TAYLOR Co., Halsey W.	*
TORMEY Company, The	47
U. S. BONDS	2
VERMONT Marble Company	45
WESTERN Asbestos Company	*
WOOD, E. K., Lumber Company	36

\* Indicates Alternate Months

## Robert W. Hunt Company

ENGINEERS

Inspection • Tests • Consultation

Schools and Other Structures  
Are Built as Designed

When Construction Materials are  
Inspected at point of Manufacture  
and during Erection by

ROBERT W. HUNT COMPANY

Cement, Concrete, Chemical, Metallurgical,  
X-Ray and Physical Laboratories

Chicago • New York • Pittsburgh  
Los Angeles • All Large Cities  
San Francisco, 251 Kearny Street

## REMILLARD-DANDINI Co.

Brick and  
Masonry Products



400 MONTGOMERY STREET  
SAN FRANCISCO, CALIF.

## ALADDIN Heating Corp.

Specializing in  
QUALITY HEATING  
EQUIPMENT

2222 San Pablo Avenue  
OAKLAND  
TWinoaks 1022

## ABBOT A. HANKS, INC. Engineers & Chemists

INSPECTING — TESTING — CONSULTING  
CONCRETE • STEEL • MATERIALS  
CHEMICAL AND TESTING  
LABORATORIES

• RESEARCH AND INVESTIGATION •

TESTS OF STRUCTURAL MATERIALS  
DESIGN OF CONCRETE MIXES  
SHOP AND ERECTION INSPECTION OF  
STRUCTURES AND EQUIPMENT  
INVESTIGATION OF STRUCTURES  
AND MATERIALS  
TESTS AND INVESTIGATION OF  
FOUNDATION SOILS  
FIRE RESISTANCE AND INSULATION  
TESTS

624 Sacramento Street, San Francisco

# ARCHITECT AND ENGINEER

PORTION OF THE GREAT SOUTH TRANSEPT, WINDOW—Grace Cathedral, San Francisco

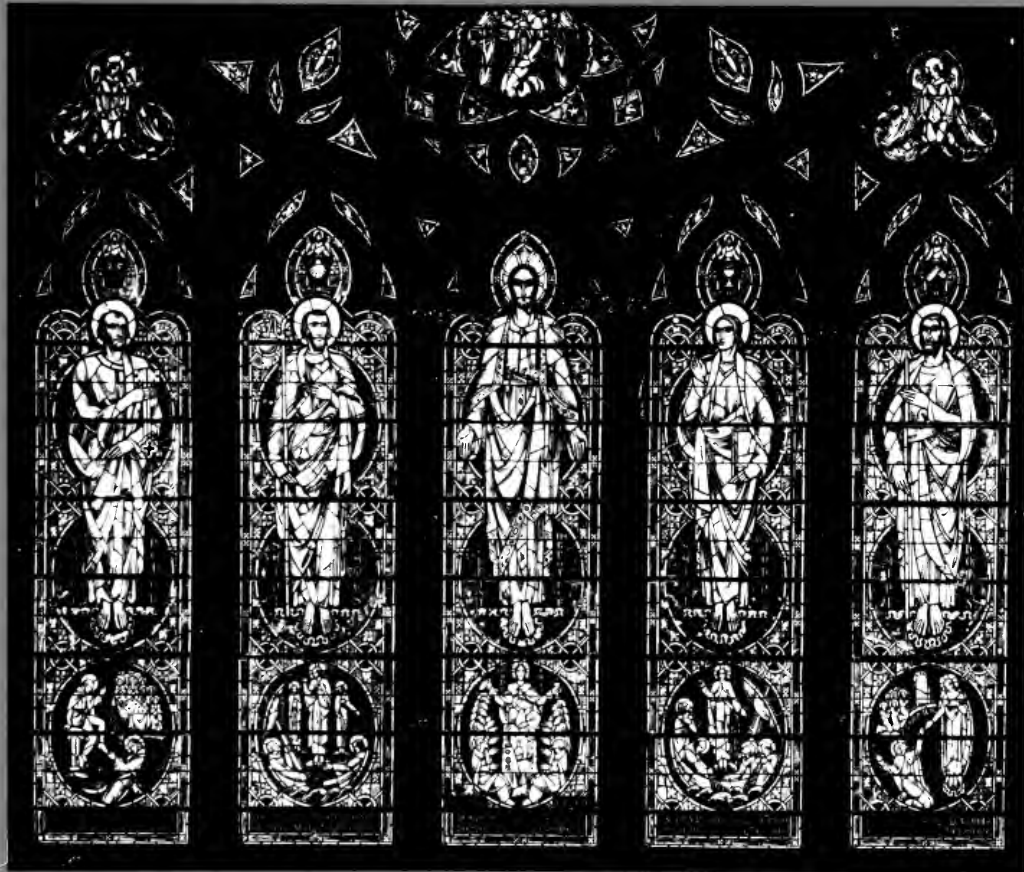

**FEBRUARY**

**1947**



Special attention to planning...

*Gas-equipped  
kitchens*

**PRACTICAL AS WELL AS BEAUTIFUL**

For the small home, this design provides economy of space and effort, plus unusual attractiveness. "Assembly-line" food preparation attains the ultimate in convenience, with *sewing* as the final step . . . employing a "snack bar" in lieu of the customary breakfast nook. Add cheer through color-harmony, and what home maker could resist this kitchen's charm?

**"pays off" in client satisfaction and good will**

Nearly 93 per cent of all city homes in California have *gas* ranges. And gas fuel is the modern choice in new and remodeled homes . . . not only for cooking, but for refrigeration, hot water service and heating as well. ★ By specifying automatic gas appliances . . . and designing the kitchen both for beauty and for conservation of energy . . . you assure that *extra* measure of satisfaction and good will which is a priceless asset to any architect or builder. ★ Your gas company offers friendly cooperation.

The West Prefers  
**GAS** 

QUICK • CLEAN • DEPENDABLE • FLEXIBLE • ECONOMICAL



# • ARCHITECT

Vol. 168 No. 2

# AND ENGINEER

ARCHITECTS' REPORTS—Published Daily  
Telephone DOuglas 8311

E. H. WILDER  
Editor

MARK DANIELS, A.I.A.  
Associate Editor

JOHN S. BOLLES, A.I.A.  
Book Reviews

MICHAEL GOODMAN  
Post-War Planning

L. H. NISHKIAN  
Consulting Editor

E. N. KIERULFF\*  
Ass't Editor  
\*In the Service



Contents for

## FEBRUARY

COVER PICTURE: Portion of the Great South Transept Window of Grace Cathedral,  
San Francisco, California

### ARTICLES AND MISCELLANEOUS TEXT

EDITORIAL NOTES . . . . .	4
NEWS & COMMENT ON ART . . . . .	6
PROPOSED PACIFIC NURSERIES, Colma, California . . . . .	11
POSTWAR AUTOMOBILES, By R. M. Schindler, Architect . . . . .	12
AUTOBIOGRAPHY IN COLOR AND LIGHT, By Orin E. Skinner . . . . .	16
RADAR, Searchlight Controller . . . . .	28
IN THE NEWS . . . . .	29, 37, 43, 46, 47
A. I. A. ACTIVITIES . . . . .	31
WITH THE ENGINEERS . . . . .	32
HEADLINE NEWS & VIEWS, By E. H. W. . . . .	36
ESTIMATOR'S GUIDE, Building and Construction Materials . . . . .	41
BUILDING TRADES WAGE SCALES, Northern and Central California . . . . .	43
CLASSIFIED ADVERTISING . . . . .	43
BOOK REVIEWS, Pamphlets and Catalogues . . . . .	45
INDEX TO ADVERTISERS . . . . .	48

ARCHITECT AND ENGINEER (Established 1905) is published on the 15th of the month by The Architect and Engineer, Inc., 68 Post St., San Francisco 4; Telephone EXbrook 7182. President, K. P. Kierulff; Vice-President and Manager, L. B. Penhorwood; Treasurer, E. N. Kierulff.

Los Angeles Office: Wentworth F. Green, 6605 Hollywood Blvd., Los Angeles 28, Telephone HEmpstead 3171.

Entered as second class matter, November 2, 1905, at the Post Office in San Francisco, California, under the Act of March 3, 1879. Subscriptions United States and Pan America, \$3.00 a year; \$5.00 two years; foreign countries \$5.00 a year; single copy 50c.



# • EDITORIAL NOTES •

## ARCHITECTURAL PATTERN MAY BE FOLLOWED

California's astute Governor Earl Warren has again taken the leadership in advocating a State Highways Program which represents one of the major development and expansion projects of the West.

The vast highways improvement program will not only benefit residents of the State of California, but will accrue to the safety, health, and pleasure of motorists from all parts of the world who use the State's highways in search of recreational relaxation or commercial convenience.

It is well, however, for engineers, contractors, and material manufacturers who may be interested in "The Highways of Tomorrow" to give some thought to the modus operandi of planning and carrying to a successful completion a highways program such as the Governor advocates.

Architects are prevented from engaging in "State work"; it would be an economic catastrophe and a solar-plexus blow to free enterprise if the engineering profession and contractors of California were to find out that the same provisions existed for "highways and public works" as now applies to the architectural profession as relates to the State of California.

\* \* \*

## THE NEED FOR PLANNING AND EDUCATION IN PLANNING

Walter R. MacCornack, F.A.I.A., former Dean, School of Architecture and Planning, Massachusetts Institute of Technology, in writing for the American Institute of Architects publication "Architecture, a Profession and a Career," says:

"The health and happiness of each individual in a community is dependent upon neighborhood design. Much of the difference between healthy, happy communities, which draw to themselves love and loyalty, and those which are ugly, squalid and confused, depends upon architects. Therefore community planning is the most important obligation of the profession of architecture . . .

"It is almost beside the point to explain the need for planning. There is abundant evidence of . . . chaotic conditions which exist in our cities and even in smaller communities. The problem is a local one, hence the need for trained men in every community . . .

"We argue the pros and cons of modern versus traditional architecture, and the words "beauty" and "functionalism" are tossed about. An examination of the arguments generally reveals that there is no deep fundamental difference between

the two sides. In the meanwhile we have almost completely ignored our obligation to create orderly and beautiful cities.

"The architect's training has for its primary purpose the organization of space. The same fundamentals of planning are found in the plan of a city and the plan of a building—order and usefulness. Each contains elements of various types and purposes which must resolve into a logical unity. Each has utilities, public space, communication areas and the need for light, air, safety, and health. So the architect's training is also a sound foundation for this field which up to the present has been considered something apart from architecture.

"The quotation 'Where there is no vision the people perish' might be applied to our cities—'Without vision, cities decay and communities perish'.

"We set up a wall in many of our schools between architecture and planning . . .

"We need to define our place in the world and to prepare to fill it—every student in every school of architecture should be instructed in the principles of community planning, which include not only the physical plan but the social, economic, and political aspects as well.

"When the architect plans his buildings with a definite consideration of the buildings adjacent to his own, of the structures in the block and of those in the general area, relating them to the city as a whole and even at times to surrounding communities—then, and then only, shall we be contributing to the glory of the cities of the future."

\* \* \*

## MECHANICAL ENGINEERS SEEK BOOKS FOR LIBRARIES

An appeal to engineers throughout the United States to contribute money for the purchase of new books, and selected used technical books and periodicals, to restore war-damaged or destroyed technical libraries in Europe, Asia and the Philippines has been issued by the Committee on International Relations of the Engineers Joint Council, American Society of Mechanical Engineers.

Information pertaining to available material should be sent to Mr. Joseph Pope, Chairman of the Book Commission, Engineers Joint Council, 29 West 39th Street, New York 18.

Since the campaign was started about a year ago, some 20,000 items have been accepted—including 4,592 engineering books; 9,526 periodical items; 5,423 bound volumes of society transactions.

Your Plans

for the Year 1947

Should Include

A Regular Schedule of

Advertising

**Reaching the West's Building Trades**

In

*The Greatly Expanding Magazine*

**ARCHITECT & ENGINEER**

68 Post Street

San Francisco 4, Calif.

Phone EXbrook 7182

Publishers of

**ARCHITECTS (Daily) REPORTS**

# NEWS AND COMMENT ON ART

## APPOINTED TO CITY ART COMMISSION

Ernest Born, San Francisco architect, has been appointed by Mayor Lapham to the San Francisco City Art Commission to serve the unexpired term of Eldridge Spencer, also of San Francisco, who resigned.

Born will serve on two committees, the Architectural Committee and the Committee on Private Structures and Improvements. The latter group passes on plans and drawings of any building or structure to be erected on city property.

Among Born's other activities is the Northern California Chapter, A. I. A., of which he is an active member.

## SAN FRANCISCO ART ASSOCIATION

Artists Anton Refregier and Hassel Smith, the former an Easterner and the latter a San Franciscan, had a number of pointed remarks to make about the New York art market in their contribu-

tions to a symposium recently conducted by the association.

Smith was especially acidulous in his views. "New York has grown like a sponge, soaking up the cultural and economic life of the country and giving little in return." Such was the substance of his comments.

"If New York is to become the cultural capital of the United States, in the way that Paris, for example, is the cultural capital of Europe, then New York must come to serve the country's cultural life rather than to demand that it be continually served by that culture," is the way Smith sums up his position.

Refregier, on the other hand, while not exonerating New York of all guilt, thinks that Westerners themselves have emphasized New York's dominance in art by waiting until its stamp of approval has been put on Western artists before buying their works.

## AS IT WAS IN THE BEGINNING



*Photograph by Philip Knight, California School of Fine Arts*

A portion of the Gallery exhibition, *As It Was In The Beginning*, recently shown at the California School of Fine Arts. The exhibit, through original drawings, paintings and prints, documents and photographs, recreated the early days of the School's existence in the seventies, eighties and nineties.

**MEXICAN SOLDIERS**

One of three oils by the late Mexican painter, Alfredo Ramos Martinez, now a part of the Museum's Albert M. Bender Collection. There are also five drawings, one done very effectively on newsprint paper.

Martinez' personality and work were of importance in the early development of Mexican painting since he, with Rivera, Dr. Atl and Montenegro, was sent to study French painting, the Barbizon School and Impressionism at government expense. The knowledge he gained was then applied to the San Carlos Academy, headquarters for all art training in Mexico.

Seventy-five per cent of the best Mexican easel paintings and drawings are in American collections.

Murals by Martinez are to be found in a Santa Barbara cemetery, and at the time of his death he was painting a mural at Pomona College.



by ALFREDO RAMOS MARTINEZ

One way to break this hold, Refregier maintains, is for Westerners to take pride in the purchase of works of local artists rather than pursue the practice of buying from dealers in New York.

"In San Francisco," he says, "the great difficulty is the complete lack of the type of gallery which acts as the artist's sole agent, having his work on hand, holding periodical one-man shows, arranging out-of-town exhibitions, seeing that his work is offered for reproduction in the art press and that he is considered for the 'prestige' commercial and industrial assignments, and, above all, seeing that these artists get in all the major annuals in the country."

**CALIFORNIA SCHOOL OF FINE ARTS**

New Faculty Members: With the opening of the 1947 Spring term the school adds four new instructors to its faculty, all of whom are leaders in their respective fields. They are: Walter Landor, Clyfford Still, Ernest Mundt and Squire Knowles.

Walter Landor will instruct classes in Packaging, an advanced course in the Dept. of Design for Commerce and Industry.

Clyfford Still, who received his academic training at the Art Students' League, Spokane University and Washington State College, will conduct classes in Drawing, Space Organization and Color.

Ernest Mundt, artist, designer and architect, will teach in the Department of Orientation, as well as basic Drawing.

Receiving his degree in architecture and art history at the Technische Hochschule, Berlin, Mundt first practiced architecture in Germany. Later he taught at the University of Michigan and Brooklyn College and was engaged to formulate special courses for the Art Dept. of the New York City school system.

Classes in Precision Drawing will be conducted by Squire Knowles, a graduate of University of California and an alumnus of the California School of Fine Arts.

In association with Ernest Born, San Francisco architect, Knowles did a variety of work for the Treasure Island Exposition. During 1944 and '45 he was a member of the San Francisco City Planning Commission, and, as Assistant City Planner, was in charge of designing publications and exhibitions.

\* \* \*

Photography classes are continuing under the direction of Ansel Adams and Minor White. They meet from 7 to 10 p. m. on Mondays, Wednesdays and Fridays.

The course is divided into three 6-week periods. The first period deals with the mechanics of photog-

## NEWS AND COMMENT ON ART . . .

raphy, the second with composition and aesthetics, and the third, practical application.

\* \* \*

### OLDEST ART SCHOOL

The California School of Fine Arts is the oldest of its kind in the West. Located originally at 313 Pine Street, the school was first called the California School of Design.

In 1893 it was changed to the Mark Hopkins Institute. The same year Edward F. Searles, owner of the Hopkins property, deeded the buildings and grounds to the Regents of the University of California, who accepted joint ownership with the San Francisco Art Association.

After its destruction by the earthquake and fire of 1906, the school re-emerged under the title of San Francisco Institute of Art and was erected on the foundations of the old school on California and Mason streets, present site of the Hotel Mark Hopkins.

It was after the name was changed again to its present one that it moved to its present site at 800 Chestnut St. in 1926.

---

### SAN FRANCISCO MUSEUM OF ART

"Start To Paint" Class: George Harris will work with a small group in eight weeks of intensive study and application of fundamental painting techniques from the School of Impressionism through Surrealism and Dadaism. The class is held on Wednesdays from 7 to 9 P. M. and will continue through March 12, 1947. All materials will be supplied.

\* \* \*

A series of lectures and dance demonstrations are being sponsored jointly by the Museum and the San Francisco Dance League. They take place on Wednesdays at 8 P. M. The program includes: (1) "Historical Background For the Modern Dance";

---

### INFORMATION WANTED

Sirs:

I am preparing a catalogue and critical analysis of the work of the American painter, Thomas Hart Benton. I would be grateful if anyone owning sketches, drawings, or paintings (exclusive of lithographs) by Mr. Benton, would please correspond with me.

D. W. Laging, Professor  
Department of Literature and  
Fine Arts  
Michigan State College  
East Lansing, Michigan.

(2) "Stage Design In Relation To The Dance"; (3) "The Use of Voice With The Dance."

\* \* \*

Alexander Schneider, violinist, and Ralph Kirkpatrick, harpsicord, will present three classic programs on February 17, 19 and 21 under the sponsorship of the Museum.

\* \* \*

Another "Famous Film Series" was recently concluded. It included "The Son of The Sheik," "Alexander Nevsky," a Russian film, and a group of Charlie Chaplin pictures.

\* \* \*

Nora Lee Rohr conducts the children's Saturday morning art sessions. Sympathetic guidance enables the child to develop individuality and originality in his approach to art. Classes begin at 11:30 for children to 14 years of age. A 10-cent admission includes materials.

---

### CALIFORNIA PALACE OF THE LEGION OF HONOR

FEBRUARY EXHIBITIONS: Thomas Carr Howe, Jr., director, has announced these exhibitions and special events for February:

Paintings by Elaine Bailey Dooley; Paintings by John Holland; Recent Watercolors by George Post; Arthur Sachs Collection: Old and Modern Masters, tapestries and the decorative arts—continuing thru February.

Paintings by Carl Morris; The Alma de Bretteville Spreckels Collection of Sculpture by Auguste Rodin; The Mildred Annan Williams Collection of Paintings, Sculpture, Tapestries and Furniture; and The Collis Potter Huntington Memorial Collection of 18th Century French Paintings, Sculpture, Tapestries, Furniture and Porcelain.

EDUCATIONAL ACTIVITIES: Children's classes, for ages 4 through 12, will be held every Saturday morning at 10:30 under the direction of Katherine Parker, Lilly Weil Jaffe and Rex Mason. Admission is free.

Painting class for adults will be held each Saturday afternoon at 2:30 under the direction of Rex Mason. Also no admission.

SPECIAL PROGRAMS: Uda Waldrop gives an organ recital every Saturday and Sunday at 3 P.M. An organ concert broadcast is also presented 3:30 P.M., Saturdays over station KSFO. FREE MOTION PICTURES—2:30 P.M., Saturday.

---

### CITY OF PARIS

Beatrice Judd Ryan, curator of the Rotunda Gallery, announced an exhibition of oils and water-

colors by Ivan Bartlett, Betty Binkley and John Howard through March 1st.

Another exhibition of watercolors at the Art in Action, Fifth Floor, will feature works by: Paul Carey, Nicholas Dunphy, Douglas Duncalfe, Cecily Easley, James Ellison, John McNee, John B. Mottram, John H. Newberry, Charles H. Rogers, and Suzanne Mullett Smith.

#### M. H. DE YOUNG MEMORIAL MUSEUM

Paintings by Ben Messick are being exhibited at the museum during February. Messick is represented in the permanent print collection of museums and galleries throughout the country as well as by murals in several California high schools.

He works in many mediums but he has gained his greatest distinction as a lithographer and draftsman. He is a realist, concerned with the human species in its everyday activities, as may be seen by such titles as: "Main St. Cafe Society," "Pitchman," and "Clown's Band."

#### FEBRUARY EXHIBITS

Other February features include: Paintings by Florine Stettheimer, February 10-March 3; Federa-

tion of Modern Painters and Sculptors, opening February 14; Paintings by Max Weber, opening February 15; The Art of Alaska, lent by Earl Stendahl, opening February 18; and Chinese Lowestoft Porcelain, lent by the Metropolitan Museum of Art, opening February 1st.

#### ART CLASSES

The beginning course in the "Painting For Pleasure" series meets on Saturday mornings, 10:30 to 12:00; also on Tuesday afternoons, 2:00 to 4:00; and Saturday afternoons, 2:00 to 4:00. Students may select any one of the periods.

Classes consist of lecture, demonstration and experiment by class members in the basic devices of art.

#### ADVANCED COURSE

For those who have completed the "Painting for Pleasure" course, an advanced course is conducted on Wednesdays, 2 to 4 P.M.

#### STUDIO

The studio is open for independent drawing and painting every day during museum hours except Sunday to those who have completed the "Painting for Pleasure" course.

#### TAVERN SCENE

by David Teniers (1610-1690)

Known principally for his representations of folk life, Teniers is the most celebrated of the 17th century Flemish artists.

This painting entitled "Flemish Interior," from the M. H. de Young Museum permanent collection, is a characteristic and particularly exquisite example of his work.



## CHILDREN'S CLASSES

Two children's classes are conducted by Miriam Lindstrom. The intermediate class—for young people 10 to 15 years old who are seriously interested in art—is held on Saturday afternoons from 2 to 4 P.M. The course is free and materials are provided.

The regular children's class meets on Saturday mornings from 10:30 to 11:30.

---

## GARDEN SHOW FEATURES MODERN THEME

"Fantasia," an expression in modernism, will be the theme of the 1947 California Spring Garden Show at Oakland, Calif., April 29 through May 4, according to Howard Gilkey, landscape architect and designer of the show for many years.

The mystery and lure of newer structural materials rarely used in gardens will feature the exhibition. Lucite, Chrystal forms, mirrors and plastics will be used to permit joining displays into a single theme, while natural beauty will be supplied by forest greenery, plants and flowers.

The show is expected to be the focal point for horticulturists the world over, bringing displays from Australia, Holland, as well as all parts of the United States.

Official show of the First District Agricultural Association, the exhibit has been presented since 1929 as a main event in the cultural and artistic life of California. The 1946 show, "Eldorado," brought an estimated gate of 150,000 persons during its run.

---

**CHANGE NAME:** The name of the Society for Sanity in Art will be changed to "Society of Western Artists," at the close of the current annual exhibition at the California Palace of the Legion of Honor.

The change, contemplated for some time, was voted unanimously at the society's annual dinner.

Haig Patigian is president of the society composed of prominent painters, sculptors and etchers of California. The two main chapters in the state are in San Francisco and Los Angeles.

It was also decided to establish a permanent headquarters for the society and, in addition to the annual exhibition, to hold a number of smaller shows throughout the year.

---

**THE WAC BARRACKS** at the Fresno (California) Fairgrounds are being moved to Orange Cove where they will be re-erected to house personnel at work on the Friant-Kern Canal.

## HOUSING TRENDS

Regional analysis of home building in 310 U. S. cities shows the most important regional gains between 1930 and 1945 took place in the South and the West. The North experienced a sharp decline during the same period.

Sections within these general regions showed marked differences, though following general trends. The Mountain states had relatively the largest population gain in the West, largely the result of huge war plants constructed there. Total home construction, however, was largest on the Pacific Coast.

The West North Central states were the largest loser during the depression migration of the thirties, while the Middle Atlantic states and New England were hardest hit by the war-boom population shifts.

AMONG OUR  
**NEW SUBSCRIBERS**  
WE FIND

ARCHITECT & ENGINEER magazine is happy to WELCOME the following new subscribers and to acknowledge their cooperative interest in the Architectural, Engineering, Contracting, and Construction industries of the West:

Madonna Lumber Co., San Luis Obispo, Calif.; H. Mayson, Contractor, Los Angeles, Calif.; Wm. Laing, Architect, Medford, Oregon; Max H. Cavette, Berkeley, Calif.; Robt. M. Evers, Oakland, Calif.; Milton J. Mudran, Richmond, Calif.; C. R. Menchavez, Cebu City, P. I.; Antonio Miranda, C. E., Manila, P. I.; Director, School of Engineers, Aleppo, Syria; Hurlburt Anderson, Jr., Boulder, Colo.; Carlos J. Tirado, Puerto Rico; R. H. Cooley, C. E., Oakland, Calif.; Walter R. Bell, Seattle, Wash.; Max Quong, China; Dale Witherbee, Seattle, Wash.; Avon M. Smith, Sacramento, Calif.; Frank Calkins, (Draftsman), Los Angeles, Calif.; Raymond Abele, Jr., Oakland, Calif.; Petersen Engineering Co., San Francisco, Calif.; Batmale & Ferrell, Contractors, San Francisco, Calif.; Elmer E. Leal, Newark, Calif.; D. P. Mayar, Engr., Lahore, India; Clayton Kantz, Owosso, Mich.; Halter & Robinson, Engineers, Redding, Calif.; Prairie View University, Prairie View, Texas; A. Varpins, Gothenberg, Sweden; C. Melvin Frank, Columbus, Ohio; Orin B. Bendfeld, Jr., Beverly Hills, Calif.; C. S. Andrews, Oklahoma City, Okla.



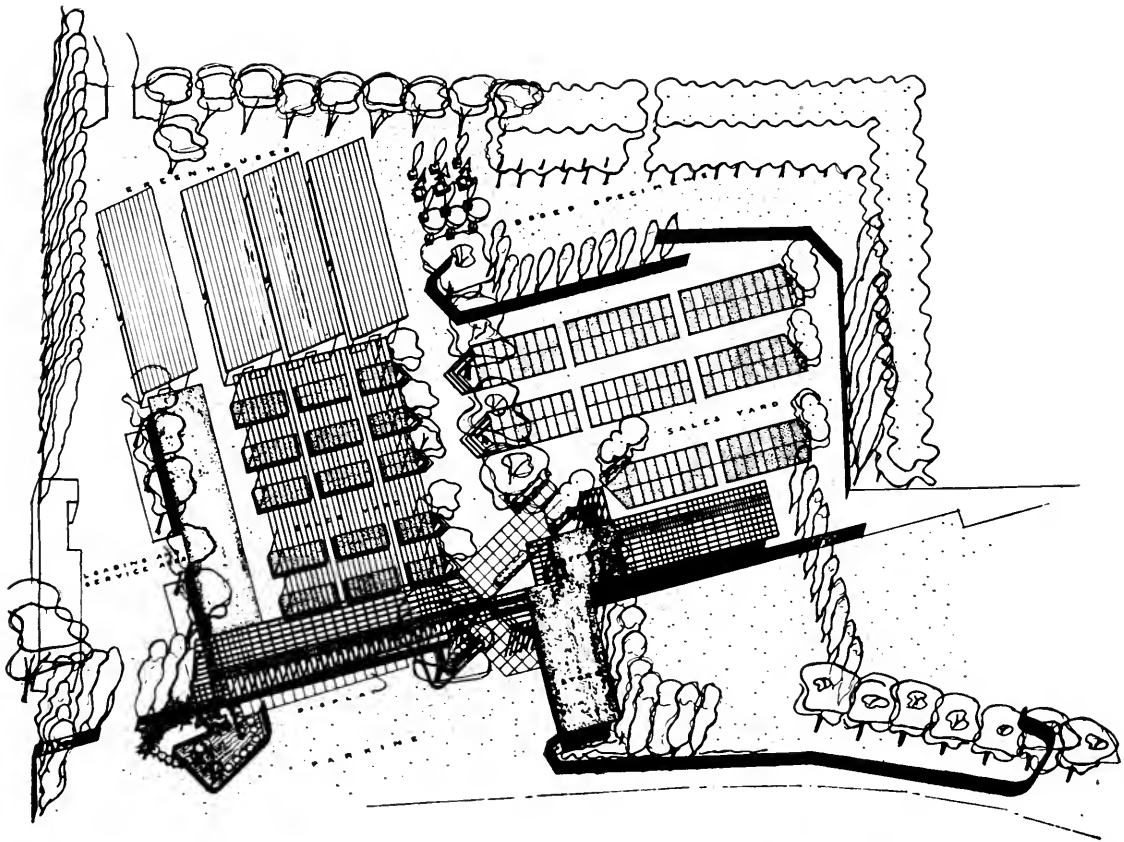

ROBERT ROYSTON, Landscape Architect

# Proposed Pacific Nurseries

## COLMA, CALIFORNIA

Isometric shows the proposed development for Pacific Nurseries, Colma. The entire forward three acres will be utilized as display sales and parking area.

The "invitation to shop," parking, display and security problems have been thoroughly studied and incorporated in this nursery space analysis.

The sales office is centrally located and controls a full view of the entire area. A clear glass screen separates parking and nursery sales yard beyond.

Wide paths allow foot and nursery vehicle traffic to all sections of the sales yard.

The central concrete terrace will provide a resting place for shoppers in connection with plant displays along the seasonal main walk.

Lath areas, glass houses and open areas are directly located for ease of maintenance, service access and visibility to the shopper. The structural tree pattern acts as a windbreak and further defines and enhances the entire sales development.

# POSTWAR

# AUTOMOBILES

By R. M. SCHINDLER, Architect

During the last twenty years when a courageous architect braved a doubtful audience to prove that contemporary architecture was not a fantastic fashion but a sensible development based on a new attitude toward living and a new approach toward production, he solemnly pointed to the automobile.

The house, he asserted, would have to be designed with the same fresh and functional spirit as the modern car. This illustration seemed convincing to many doubters, who assumed that the automobile was functional simply because it had lost the features of the old coach. "Form follows function" is a principle which actually had very little influence in shaping prewar cars.

The war cut the evolutionary thread of the automobile. With production machines and dies in the dust heap, it is a good time for the architect to evaluate his much vaunted example of contemporary design as a possible basis for the development of a really functional car.

Yesterday's designer had one seemingly irrefutable proof of progressiveness: streamlining. His bullet shaped car whizzed irresistably from one point in space to another. The speed-hungry public was impressed, but actually streamlining did little to reduce air resistance and power consumption. The average car in action rarely travels on a straight, empty highway at full speed. Most of the car's existence is spent in short spurts between starts and stops on crowded city streets, with the concrete curb on one side, cars on the other, and pedestrians sprinkled in between. The car of the future will see even less of the open road, since the airplane has reduced it to the status of a tenth rater as a means for rapid long distance travel.

What are the consequences of such considerations in a functional design? The car should be as short as possible, for maneuverability in traffic and parking, and to utilize a minimum of street surface. The importance of relieving city traffic might make it worth while to take a tip from the whippet: provide a stretchable wheel base to elongate the car for those rare cross country trips.

But instead, there is the tendency to extend the car beyond its necessary wheel base length, by the addition of a streamline bustle several feet long swishing dangerously right and left into adjoining traffic lanes, catching curbs, and scraping garage ramps.

Such a bustle is actually being proposed in a recently published design. The one-track mind behind the super streamline picture in addition suppressed all indications of doors, keeping it completely in the realm of fantasy.

The second baseless fixation of our car designer is his insistence on maintaining an axis of symmetry at all costs. This forces him to introduce many unnecessary or impractical features. It is obvious that the natural outer surroundings of the car are strongly unsymmetrical: dangerously moving traffic on the left, a curb and sidewalk on the right. This inequality is emphasized by placing the driver's seat and all his equipment on the left. Consequently, an inflexibly symmetrical design for the body, including windshield, instrument panel, etc., becomes a dishonest tour de force, violating all functional principles. Yet the designer will go to any length to preserve this artificial symmetry. See the stop lights paired symmetrically in the rear, with an unnecessary third light to keep the license plate in the center. (At the same time he

sacrifices a really useful road light for the many occasions when a car has to be backed in the dark.) Consider that the doors on both sides of the car are always identical in size and shape, whereas the use of the one on the curb side should be favored as much as possible.

The third unfortunate characteristic of the American car is due to the designer's conviction that quality and luxury are best expressed by bulk and weight. The innocent American vehicle, whose sole purpose is simple motion from point to point, bears down the road with a defiantly protruding, wedge-shaped glittering, grimacing tank-like mask. The European designer is much more likely to understand that lightness, elegance, and charm are the really priceless attributes of development. The present American car could lose twenty percent of its length, height and weight, and emerge much more civilized.

The designer's excuse that present characteristics are demanded by the purchaser is a lame one. All models on the market are built so much on the same last that it is impossible for the buyer to assert his better taste or to improve his judgment. Imagination, taste, and courage of conviction seem to be gifts entirely lacking among the present group of reigning designers, all of whom are ready to force their sale by slight variations on the same theme. They are abetted in this by the publicity office, which meticulously avoids giving the public any real knowledge about quality and usefulness in a car, trying instead to attract buyers by moronic slogans and meaningless illustrations.

The few bantam size cars that were recently tried on the market did not give a true picture of public reaction to small cars. The designers made the basic mistake of retaining all features of the standard car in miniature. It is obvious that the average driver in a midget size car looks ridiculous as if he were wearing his son's pants. A reduction in scale must be coupled with an entirely new design, not in the slightest reminiscent of the standard car, in order to avoid the repugnant feeling a midget gives the normal size man. How could such a simple psychological effect of scale have been overlooked?

Considering further the various parts of our car, we find they are as little the product of functional thinking as the general conception. The driver's most important protector of life and lucre is the bumper. Today it is largely an ornamental appendage with very little use in a collision, the emergency for which it is obviously being carried around. To work, it should be made of really elastic, shock-absorbing material (maybe air-filled rub-

ber tubes), should be sufficiently wide and be extended along the sides of the car to protect as large an area as possible. In contrast to such a natural specification, the height of design idiocy was reached in those models where the bumpers were narrow chromium plated wedges of metal. This shape concentrates the force of impact at one contact point, this multiplying the destruction. The same effect is obtained on most other bumpers by the addition of vertical extensions, which for the sake of streamlining project ram-like in front of the contact surface. To make sure that the little give in the average bumper will destroy something at the slightest provocation, most of the new models provide a solid metal space filler between body and bumper. This gadget further serves to make the attachment of a trailer-hitch a major operation.

A semantacist would have quite a time with the word "fender." It means a device which fends or holds off something. But alas, this meaning has undergone a change. The word now suggests a device for recording the driver's unhappy total of miscalculated distances. No doubt the fenders were intended to keep the mud from flying in the driver's face. Today they constitute a prolific source of grief. The designer places four monstrously over-sized bulbous shapes at the four most exposed corners of the car. He fabricates them with devilish forethought out of material that will scratch and dent under the slightest impact. Although the wheels show a tendency to diminish in size, the fenders are continually growing until in some of the "latest" they stretch useless extensions across the whole side of the car, door and all.

Why not provide instead simple mud guards made of some elastic material like rubber, and reduce their size and weight to a minimum by fastening them to the wheel axel instead of the car body. How much bulk, cost, trouble and repair time the driver would save! And why not follow through and replace the chromium plated, perishable hub caps by ones that are less allergic to curbs, or possibly recess them behind the surface of the tire in order to take them out of the way of the curb.

We still remember the hue and cry raised against the modern architect who designed a store front consisting of large areas of plate glass between slender metal bars. Conventional eyes insisted that heavy masonry supports were needed to make the building "appear" secure. The same mentality requests that the mechanical power plant in the automobile appear as large as the horse it replaces. Since the engineer is able to

## POSTWAR AUTOMOBILES . . .

create a small compact engine, the designer satisfies convention by covering it with a hood big enough to house a railroad engine. Therewith he erects in front of the driver an empty barricade which will effectively block his view of the street. It may be true that this bloated frog's chest does not interfere much with driving on the highway, but it is definitely a handicap for the driver who has to battle with pedestrians, dogs, traffic buttons and stop lights, especially on the upgrade.

We need not dwell upon the front face of the hood. This is the area where the ambitious designer has chosen to prove his mettle, by attaching to it the dizziest, chromiest products of his imagination. He executes them largely in pot metal, the most brittle material he could find for the most vulnerable part of the car. The result of the ultimate ideal is something like the spangled uniform of a hotel doorman.

Wouldn't the repairman shout with joy if after the conventional fender had been eliminated the designer would give him a simple, small and therefore completely removable hood. And wouldn't the driver thank him if the steering wheel were taken out of his sight line, to give a clear view forward and all around. It is unbelievable by true that nearly every car top on the market produces at least two blind spots, each large enough to hide completely a car traveling close enough for a dangerous collision from the driver's observation.

Hypnotized by his streamlining fetish, the designer has not yet discovered that our car plays a different part in our lives from that played by the respectable victoria, which the lord of the manor used ceremoniously to impress the populace. Our car not only takes us to play and work, but brings home the groceries, carries the salesman's samples, moves an occasional piece of furniture, takes us to outings carrying sports equipment, shows us the sights, gives us a refuge for making love and offers us a place to eat a snack and take a rest. Therefore the traditional interior, with its upholstered seats, is entirely inadequate. The interior of the car should be an unencumbered space in which only the driver's seat need have a fixed position; one which will inconspicuously place him out of reach of a demonstrative passenger and insistent back seat drivers. All other seats should be collapsible and removable. In such a car the present complicated details of wall and floor and their intersections could be eliminated,

and the interior become a smooth, easily cleaned and washable surface. There would be no loose rubber mats, wrinkly rugs or spotty upholstery, no heavy and bulky doors which have to be slammed noisily like dangerous guillotines, and which are neither waterproof or dust proof. Decidedly, a removable top. Removable cupboards and practical closets instead of the odd dusty spaces into which we now stuff spares and luggage without discrimination. A small collapsible table with containers for records and papers. A good reading light. A place to hang coats and hats so that they remain wearable. A ventilating system powered by the motor. The car should become smaller and nimbler all around, and forsake the heavy monumentality with which the present owner is supposed to impress his creditors.

Color too has been neglected in its functional aspect. It can be used to make traveling safer. Every space architect knows that colors are of two kinds: recessive and aggressive. They create an illusion of increased and decreased distance observer and the surface. It is obvious that an aggressive color on a car will induce other drivers to give it a wider berth. The prevalent black and blue invite collisions. As for the nickleplated strumpet's jewelry hung on the front of the car, it causes disturbing reflections in traffic, increases cost of upkeep and serves only to disguise faults in body design.

Will the designer finally awaken to functional thinking and avoid the heavy responsibility he now shares for accidents? Present discussions do not seem to give us much hope. Indications are that the postwar car will merely have another fly-catching slogan, "Plastics" added to the old one, "Streamlining," without really coming of age or even reaching adolescence.

The criticisms use only functional considerations as a frame reference, and do not venture into the realm we "contemporary architects" are ultimately striving for: "organic design." This means that the many parts of the vehicle would not be shaped and joined arithmetically to fulfill their mechanical function, but that they should at the same time become harmonious members in a symphony of shapes, achieving formal unity, meaning and expression. The engineer and the designer no longer at cross purposes, but becoming one. The final machine without the sugar coating of the body stylist, a machine which functions and expresses at the same time.

## **FRANK LLOYD WRIGHT ASSAULTS TOMBSTONES**

A huge mortuary that will "take the curse off this death racket" is Frank Lloyd Wright's latest assault on the established tenets of architecture.

Commissioned by Nicholas P. Daphne to design a mortuary with built-in helicopter service near the Mint in San Francisco, the architect is flexing his muscles for another rain of blows on hoary tradition.

"A place where you go to see the last of your earthly companions should be a happy place," he said. "It should leave you with a feeling that death is no curse, that all is not lost because of it."

The distinguished 77-year old architect, who became world-famous largely by smashing time-honored concepts, submitted his plan to the San Francisco Division of City Planning recently. It looks more like a miniature world's fair than a place of entombment, and is expected to cost \$500,000.

"If death is ever to be looked upon as a friend, then architecture can render that service better than anything," Wright asserted. "A sense of beauty. Musn't lose a sense of beauty. People will weep, certainly. But give them a lift with beauty. Put living things around—flowers that grow, not bouquets that smell."

## **FM INCREASING**

Frequency modulation (FM) broadcasting, which permits listeners to hear all sounds audible to the human ear without static or background, is increasing in popularity so fast that Radio Communications Commissioner Charles R. Denny, predicts that, "in years to come, this new service will develop to a point where there will be 1,000 or more transmitters and 50,000,000 receivers."

Megacycles, or millions of cycles, will be the frequencies used by FM, compared with kilocycles, or thousands of cycles, as used by AM, or amplitude modulation.

FM has lowered broadcasting equipment costs. An FM station can be equipped for as little as \$6,500, depending on the station's power. About 300 conditional licenses have been granted.

## **RETAIL SURVEY MADE**

A survey on services and retail trade establishments which will be used as a basis for community planning and zoning is reported by Joshua Vogel. The development of a model shopping center for Bellevue, Wash., resulted from a survey of this type, some of the buildings for which were designed by chapter members.

This data served to show investors that the project would be a profitable venture over a period of years and enabled architects to plan on a wide area basis.

Another survey with a school population map showing bus transportation routes and sites available for a 3000-student athletic center has been completed for Everett, Wash.

Tentative layouts for a stadium, field houses, natatorium, baseball and football fields, and tennis courts. The principal purpose, however, was to determine the needs of the general area. School officials, local architects and engineers would carry on from there.

Walla Walla, Wash., is in the midst of a land use survey and is awaiting an origin-destination traffic survey which the city is having made by state highway engineers.

## **STANDARDIZATION PROGRESS**

A 25-nation convention is proposed by the International Organization for Standardization to promote the adoption of uniform standards for industrial products. The American Standards Association has already indicated its willingness to cooperate.

Sixty-four projects have been accepted for action. They include: iron and steel, metal food containers, agricultural machinery, still photography, moving pictures, metric and inch threads, ball and roller bearings, modular building planning, nuts and bolts, sheet and wire gauges, tools, automobiles, and many other types of products.

Standardization will aid the flow of goods in international commerce, Dr. P. G. Agnew, vice president and secretary of the American Standards Association, said recently. He pressed for immediate ISO action on as many products as possible.

## **CUT CARRYING CHARGES**

Rental housing will take the spotlight for 1947, reports from Washington indicate. The Federal Housing Administration has announced a reduction in monthly carrying charges on the financing of new multiple housing projects, the object being to encourage rental construction.

The amortization rate on rental projects has been cut from 2% annually to 1½%, and applies to all mortgages insured under section 608 of Title VI. These mortgages will now mature in 32 years instead of 27 years.

## **HOME BUILDERS SURVEY**

A survey of home builders to determine the problems facing individual builders at the moment is being conducted by the National Association of Home Builders. The contractors are being asked to list their current bottlenecks in order of importance. When all the pertinent data is in, it will be presented to the government officials concerned and attempts made to modify policies and regulations that are impeding the home building industry.



Moses and Abraham—clerestory windows in the east wall of the south transept of Grace Cathedral, San Francisco. Lewis P. Hobart, Architect. Designed and made by Charles J. Connick and his Associates.

# AUTOBIOGRAPHY

ARCHITECT AND ENGINEER

# IN COLOR AND LIGHT

ORIN E. SKINNER

Great architectural structures, especially noble cathedrals, have strange ways of revealing the character of their builders. They stand, not only as sermons in stone, but as autobiographies of those who created them. We are drawn to them by the unseen hands of architects, masons and the countless horde whose faith and hopes are there set forth in visible form.

We like to follow the changing mood of a people as recorded in their building over periods of many years—sometimes centuries—and trace the indelible print of character in stone, wood, and glass.

The signatures of the craftsmen in stained glass are, perhaps, most evident, for windows are the

---

One of the series of four nave windows in the Chapel of Grace, San Francisco, California, presenting in medallions the life and ministry of Christ, as narrated in the Gospels of Saint Matthew, Saint Mark, Saint Luke and Saint John. Lewis P. Hobart, Architect. Designed and made by Charles J. Connick, Boston.

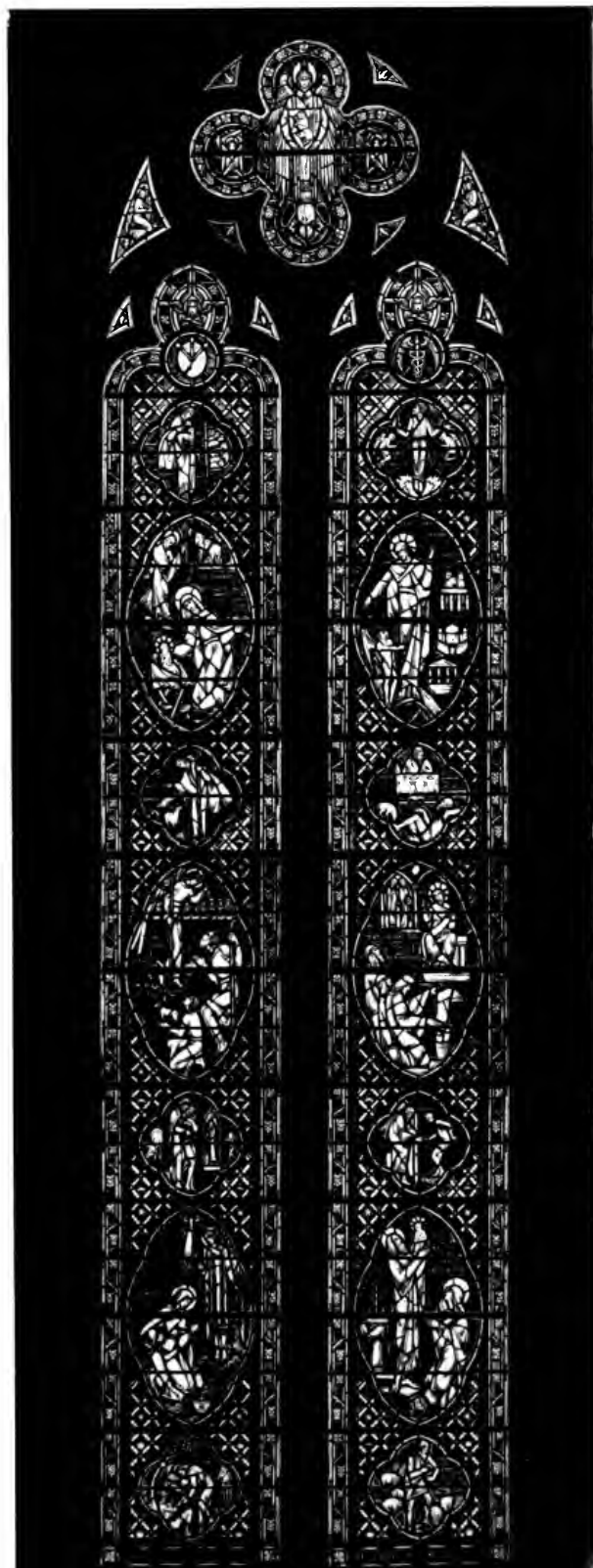

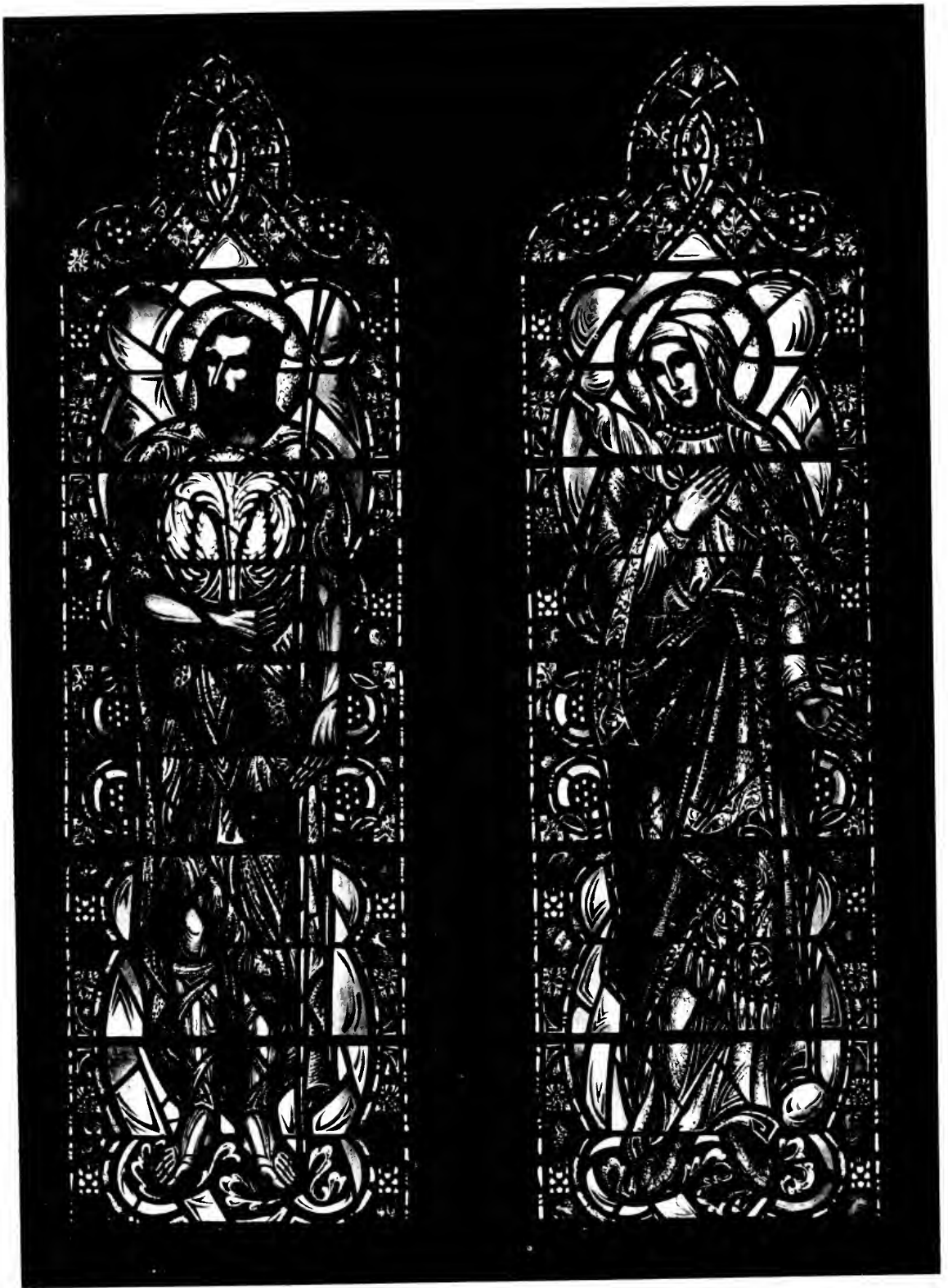

Dominant figures of Saint John the Baptist and Saint Elizabeth—upper part of lancets of choir window, Grace Cathedral, San Francisco. Lewis P. Hobart, Architect. Designed and made by Charles J. Connick and his Associates. Completed February 1946.



cathedral's most obvious enrichment, both in color and in light.

We can clearly read the sturdy character of those ancient master-craftsmen, although they seemed to try to conceal their identities; for we know the name of only one of them, and that through a window in the Cathedral of Notre Dame, Rouen, inscribed in the Latin of the times, "Clement of Chartres made me."

Our own cathedrals may not require so long a span of time in building, but, nevertheless, they reveal their own suggestions of contemporary biographies, often recording the development of artists and craftsmen over comparatively long periods. Such a one is Grace Cathedral in San Francisco, where seventeen years of the flowering art of Charles J. Connick is recorded in the windows. Though ever-changing, through all of them runs the basic character of good craftsmanship to unite and harmonize varying instruments and notes into one symphony of color and light.

The recent addition of four great windows,—two in the choir and two in the nave, and the glazing of all the remaining windows in temporary glass,—at last makes it possible to view all of Connick's work in a friendly atmosphere. Adequate in color and design to control earlier conflicting lights, this temporary glass blends with the permanent windows in amazing fashion, and gives them the setting they had so urgently needed.

These windows were completed by Connick's associates after his death in December 1945. They are carrying on his work in the same spirit which distinguished his earlier creations.

Mr. Connick's introduction to the Cathedral was through the windows of the Chapel of Grace in 1929 and 1930—four in the aisle, and the apse group of the same number, together with the baptistery window.

---

**Baptistery windows in the Chapel of Grace, Grace Cathedral, San Francisco. Our Blessed Lady with Holy Child and three cycles of Mysteries of the Rosary.**

**The Annunciation  
The Crucifixion  
The Resurrection**

**Designed and made by Charles J. Connick, Boston. Lewis P. Hobart, Architect.**





Here the artist was given a most gratifying opportunity to serve his fellow-men in jewelled medallions devoted to those endearing narratives, the four Gospels. Since the chapel is reminiscent of the traditional Lady Chapel, the baptistery window at its entrance is devoted to Our Lady and the Christ Child, with her symbols of lilies and roses, and medallions representing three cycles of Mysteries of the Rosary,—the Annunciation, Joyful; the Crucifixion, Sorrowful; and the Resurrection, Glorious.

In the four double windows devoted to the Gospels, each Evangelist is represented by incidents and characters which he emphasized. Saint Matthew's window stresses Christ's Teaching; Saint Mark's Gospel emphasizes the Miracles; Saint Luke introduces the Birth and Childhood of Christ and is marked by sympathy with suffering. Saint John's window, like his Gospel, suggests the poetic and interpretative, as well as the inspired narrative.

The four chancel windows are devoted to the Passion of Christ as it is recorded in all the Gospels. These windows slightly emphasize the warmer areas of the spectrum, and so contrast in gentle manner the cooler radiance of the nave.

Since the dominating areas face the south, the windows of this chapel are often touched with brilliant light, and at the same time they interpret all the other moods of Brother Sun, and have they own way of reacting to the color of the weather.

The emphasis is upon the cooler qualities of color, and this interior is gratefully accepted as a quiet place of meditation and prayer. Here Mr. Connick was feeling out the dominant note in a somewhat traditional manner. The group may well be considered as a choral prelude to the full radiance and power of the Symphony that was to mark the fulfillment of his hopes for the great windows of the choir, nave and transepts.

---

**Virtues Window in south chancel, Grace Cathedral, San Francisco—devoted to Saint Louis of France and Saint Genevieve. Designed and made by Charles J. Connick and Associates, Boston. Lewis P. Hobart, Architect.**

The three central chancel windows were undertaken next, and were completed in February of 1931. The nine great windows of the chancel and choir were chosen to represent, in related symbols of light and color, that poetic inspiration of Dionysius, the Nine Choirs of Angels, later set forth in all its powerful significance by Dante in his *Divine Comedy*. Each member of the Angelic Choir presents a spiritual quality that is approached or definitely attained by distinguished and saintly men and women through their earthly achievements.

The Seraphim, symbols of Divine Love, nearest the Throne of God, take the dominant central position, with the Cherubim of Divine Wisdom at the left; and Thrones of Divine Justice and Steadfastness at the right.

These three windows are seen at the greatest distance of any in the Cathedral, and the luminous and powerful figures of Christ the Light of the World and the Good Shepherd are designed to emphasize the supremacy of loving leadership so clearly that their message may serve as a joyful welcome to all who enter the far eastern portals of the finished Cathedral as well as an accompaniment to the worship within its walls. They are designed in a most interesting counterchange of the dominant colors, ruby and blue, and can be seen to best advantage in the afternoon sunlight, which suggests the promise of a comprehensive and significant radiance of the whole group. However, they are lovely in every mood and should be contemplated in the ever-shifting light from early morning 'till late evening, and through the changing seasons.

The south transept window was completed near the end of 1931. The central panel under the rose is devoted to Our Lord. On either side are Saint James, Saint John, Saint Peter and Saint Thomas. These figures, with their well-known symbols, and



---

**Angels Window—north chancel window nearest the transept of Grace Cathedral, San Francisco—devoted to Saint Elizabeth and Saint John the Baptist. Designed and made by Charles J. Connick and Associates; completed March 1946. Lewis P. Hobort, Architect.**



their eloquent medallions, serve to sing forth in the brilliant southern light, the undying qualities in Christian brotherhood that include even the implication of questioning that is so apparent in modern life and thought.

The rose lifts its soaring tracery above the lancet panels to accentuate the good works of that brotherhood by symbolizing the Seven Angels of the Seven Churches of Saint John's Revelation. Its fields are predominately blue, but the accents of significant ruby and gold through the groups of figures bear suggestions of radiance even on rainy days.

The north transept window, made the next year, follows the mighty implication of the south transept, and recalls venerable traditions in Christian art, through the dominating figures of King David, the ancient prototype of Our Lord.

The expression of the spirit and nature of the Old Dispensation is further emphasized in the figures of the Major Prophets, Isaiah, Jeremiah, Ezekiel and Daniel. It is made brilliantly articulate in fields of rich ruby and gold to hold its values in an aspect of the northern light; with pleasant passages of pure blue, relating it to the opposite window in the south.

Another window in the choir, devoted to the Archangels, was completed and placed in 1932. It is near the crossing in the south wall. The dominating figures are Martha and Saint Paul, who stand as types of the Archangels' spiritual influence on earth.

The spring of 1933 marked the completion of the two high clerestory windows in the east wall of

---

**Aisle window (left) symbolic of love—Saint Mary Magdalene and Saint Martin of Tours—in Grace Cathedral.**

**The Great South Transept Window of Grace Cathedral (right).**

**Designed and made by Charles J. Connick, Boston, Mass.**

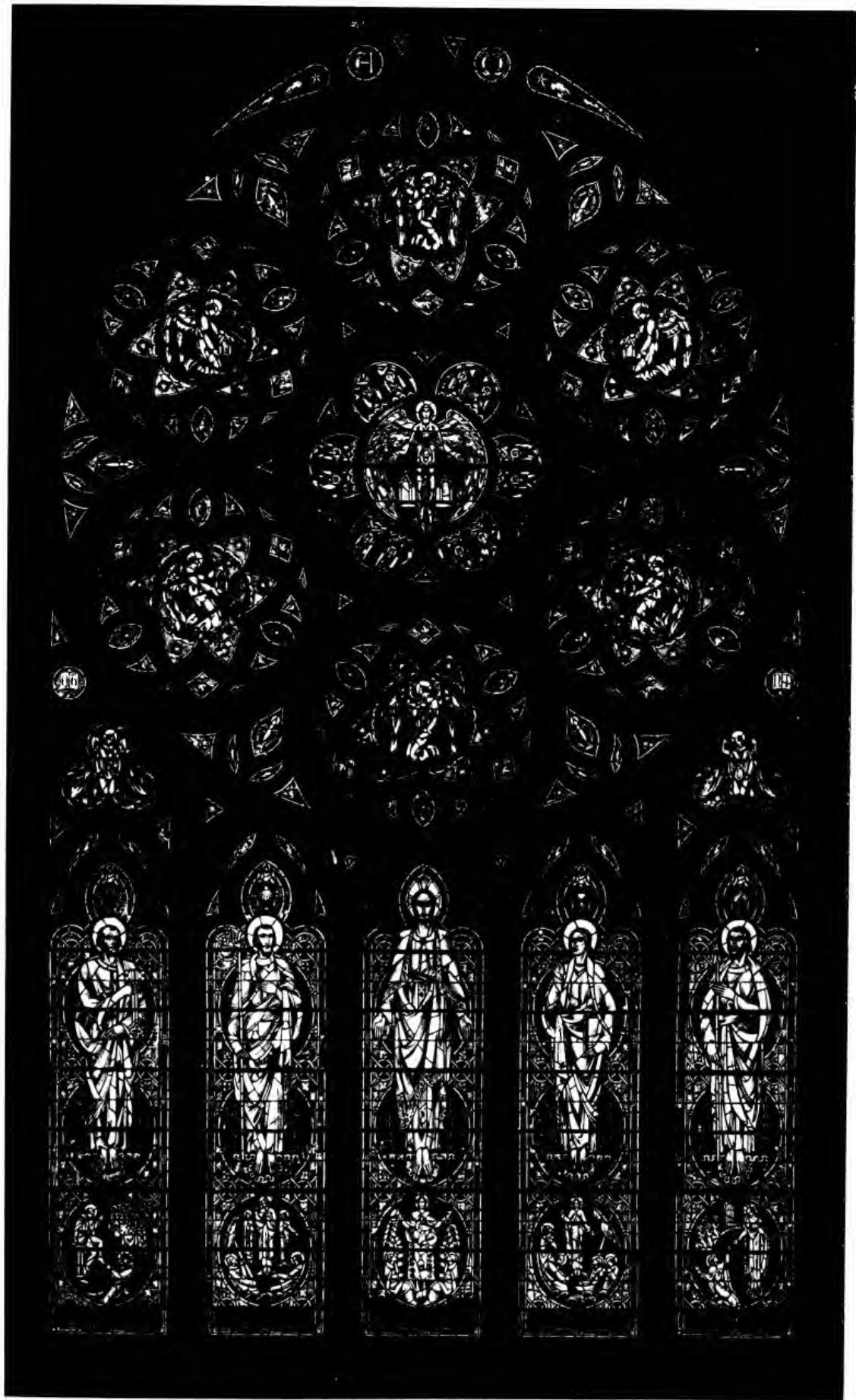



the south transept. They introduce a new note in monumental figures, simple and rugged, devoted to the beginnings of Christianity,—the Patriarch Abraham, and the Law-Giver, Moses.

Gideon, mighty man of valor, and Joshua, warrior, with his sun shield, have been designed for the corresponding positions in the north transept.

In the fall of the same year came the opportunity of designing and making the first of the nave windows. The chosen scheme further emphasizes the concept of unity that should mark the enrichment of a vast interior.

Christian art has furnished a precious theme for the twelve aisle windows in its amplification of Saint Paul's glowing words about the Fruit of the Spirit, in the fifth chapter of his epistle to the Galatians. This theme has had a distinctive place in the expression of Christian ideals from a very early period, developing from the fundamental Christian idea of the inner struggle between virtue and vice, to find almost perfect expression in the art of the great Gothic cathedrals, notably at Paris, Chartres and Amiens.

The first window on the south was devoted to the first of these Virtues,—Love. Its spiritual quality is suggested in the character and details of the design itself, and expressed throughout in the significant use of color. The allegorical figure in the rose is clothed in garments of red, the color of divine love and charity; and gold, suggesting love as the source of spiritual riches. Her cloak is wrapped about a child, and she holds a flaming heart.

The theme is further reflected in the representations of Saint Mary Magdalene, and Saint Martin of Tours, whose stories are developed in the lower medallions.

Mr. Connick designed these windows for closer observation, and every line of figure and foliated composition is carried out in exquisite detail. The window is characterized by lighter passages of color with a notable vermilion red, light clear blue,

---

**Window in the Chapel of the Intercession, Grace Cathedral, San Francisco—symbolizing Prayer and Praise. Designed and made by Charles J. Connick, Boston. Lewis P. Hobart, Architect.**



Two of a series of four windows in the chancel, Chapel of Grace, Grace Cathedral, San Francisco, California. Designed and made by Charles J. Connick of Boston, Mass.

Completed January 1930.

Lewis P. Hobart, Architect.

*(Photo from the cartoons)*



**Cartoon of Center Apse Window—"Seraphim," with details of the actual windows dominant figures—Grace Cathedral, San Francisco. Designed and made by Charles J. Connick and his Associates. Lewis P. Hobart, Architect.**

gold, and notes of luminous cool green.

The lower areas of the north transept's west wall was enriched with suggestions of love and tenderness through the window that honors the children of the Old Testament. This window, made in 1934, is designed in medallions, large and small, accompanied by youthful figures, birds, flowers and growing forms that clearly reflect Mr. Connick's love of all the expressions of Nature. It also introduces new characteristics of design that had been forming in Connick's mind, through the intricate interlacing pattern of growing vine outlining the

medallions and flowing into the border. It carries implications of freer and less conventional forms than we find in many of the larger windows.

The window in the Chapel of the Intercession takes its place as something of an interlude in the symphonic composition. It is designed in light tones and lacy pattern to provide a gracious illumination for the chapel, and is articulated by small figures—angels of prayer with censers, and a central angel of praise with a trumpet. It was completed for the Christmas season of 1936.

As a most significant further development of



the theme of childhood and its implications, the window devoted to the Twenty-third Psalm in the lower east wall of the south transept balances the Old Testament window, interpreting in light and color that beloved song of faith in the Lord. They are quite similar in design, but Mr. Connick has introduced much more pure limpid blue throughout the composition. It was completed in 1941.

The two aisle windows placed in 1946 were designed before Mr. Connick's death, and complete the present south aisle. They are devoted to the qualities of Joy and Peace, with the dominant figures of Saint Catherine of Siena, Saint Francis of Assisi, Saint Barbara and Saint Giles. They carry on the plan of the Love Window with interesting variations. The theme of Joy suggests a domination of brilliant blue while gold and silver receive more prominence in the Peace Window, with warmer greens.

The windows symbolizing the Choirs of Angels and Virtues, also completed by the Connick Associates, both predominate in blue. The former, devoted to Saint John the Baptist and his mother, Saint Elizabeth, is decidedly a blue window, sparkling and lively, while the mantle of Saint Louis and the robe of Saint Genevieve dominating the latter, are both of pure limpid blue. The figure representing the choir of Virtues in the great upper rose, wears golden armor and holds a crown of stars and a sceptre to symbolize divine strength and fortitude.

To those who look for their significance, these windows all bear eloquent testimony to the ever developing character and changing expression of the designer, and reveal the promise of glorious color and light that the Cathedral will possess when the nave is extended and all of the glass is installed.

---

**Window symbolizing the Twenty-Third Psalm in the lower east wall of the south transept, Grace Cathedral, San Francisco. Designed and made by Charles J. Connick, Boston. Lewis P. Hobart, Architect.**



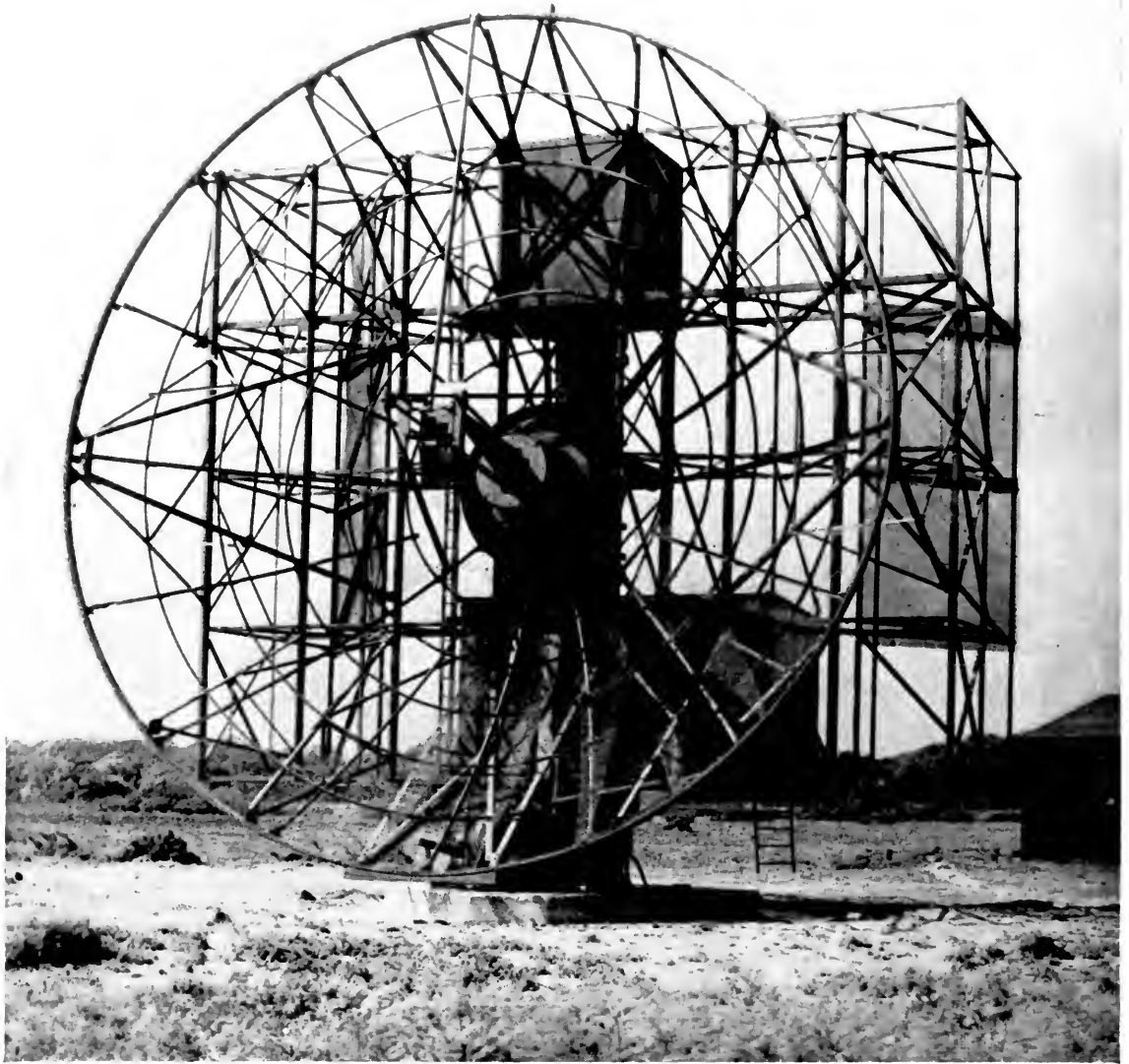

# RADAR CONTROLLER

## SEARCHLIGHT

During the "fighting days" of World War II, development of Radar equipment made the operation of searchlights 100% efficient. In England the Radar Searchlight Control, which was familiarly known as "ELSIE," was used extensively against the flying bombs 1944, and for pursuing nightfighters in the clear skies of the Middle East. When the order "EXPOSE" was given a great beam swept across the night centered on the target aircraft. Radar will be used in many ways to add to the comfort and convenience of modern living.

## IN THE NEWS

### COAST-TO-COAST TELEVISION

The Bell Telephone System is jumping into the television picture with both feet with its three-year construction program of 12,000 miles of coaxial cable that will make possible coast-to-coast television broadcasts. This long-cherished dream of electronics experts and engineers is to become a reality by 1950.

Coaxial cable is tailor-made to fit the requirements of all types of terrain. Through cities it is placed in conduit, while through areas subject to frequent electrical storms it is enclosed in a special copper jacketing.

The first coaxial tubes were about a quarter of an inch in diameter. Because of the wider frequency bands contemplated, the diameter has been increased to three-eighths of an inch. The larger tubes permit auxiliary repeaters to be stationed eight miles apart, and the main repeater stations as much as 150 miles apart.

These repeaters make up for the weakening of the signal in passing over the cable. Toward the

end of an eight-mile section, the strength of the signal may be only a hundred-thousandth as great as it was at the beginning of the section.

Most of the auxiliary repeaters are in small unattended buildings which are visited only in case of trouble or for periodic routine inspection tests.

### STORAGE PLANT FOR YUBA CITY

Yuba City, Calif., will shortly have a new \$150,000 storage building when the Yuba City Walnut Growers Association complete their one-story and basement structure of reinforced concrete and steel. Preston M. Jones of Berkeley, Calif., is the structural engineer and Younger Construction Co. of San Francisco the general contractor.

### ADDITIONAL ACCESS LUMBER ROADS

Funds have been allocated to the Department of Agriculture for use of the U. S. Forest Service in constructing access road projects to reach out-of-the-way Government timber lands.

The road projects total 68 miles in length and will make available some 75,000,000 feet of timber for the Veterans Emergency Housing Program.

Scheduled for development is a 28-mile sector of the Clackamas River Road from Escatada to



## MARCH is RED CROSS MONTH

BE HIS FRIEND FOR LIFE-  
-GIVE GLADLY

**They Still Need Your Help**

Cripple Creek in Oregon; a 7-mile spur of the Roaring River Route from the Clackamas; 10 miles of Happy Camp Road in Oregon; the Twisp River Bridge and 3 miles of road in Washington; and about 20 miles of spur and feeder roads off the Trinity Forest Highway in California.

Total cost of the projects is estimated at \$1,300,000.

### ENOUGH MATERIALS

"Unless strikes seriously interfere, there should be enough materials for 1,200,000 new permanent homes in 1947," Douglas Whitlock, chairman of the Building Products Institute," declared recently. "Inventories of materials in the hands of manufacturers and distributors should increase substantially during the remaining cold weather months, when production of most building products will exceed the quantity put in place," he stated further.

### FHA CHANGES

Changes in the procedures of the Federal Housing Administration designed to encourage larger production of rental dwellings for veterans have been announced by that agency.

Three broad avenues of approach are to be used: (1) conversion of existing structures, as the quickest means of obtaining low rental units; (2) con-

struction of two, three, and four-family units and (3) construction of large-scale rental structures.

Among the policy and procedural changes made by FHA, and announced by Commissioner Raymond M. Foley, are: minimum property requirements, previously in effect, will hereafter be used as a guide, and local FHA staffs may accept alternates that will produce structurally sound and well-designed projects; FHA's cost estimation system has been revised and simplified, sharply reducing processing time; and rehabilitation of large apartment buildings, hotels, or commercial structures will be encouraged to produce additional family units.

In cooperation with lending institutions FHA will give ready consideration to readjustment of mortgage terms to enable projects built under emergency conditions to maintain their competitive market position. This will involve re-writing of mortgages in cases of decreased earnings.

### CHAMBER PRESIDENT

Henry B. King of the sales division of W. P. Fuller & Co., San Francisco, has been elected president of the San Francisco Junior Chamber of Commerce for 1947. He succeeds Matthew C. Carberry, retiring president, who was recently elected to the board of directors of the San Francisco chamber.



*To architects and school authorities—  
Be sure to specify America's  
foremost fountains for '47*

In new construction or for replacements, make sure your 1947 plans call for Halsey Taylor Drinking Fountains. All over America, especially in school installations, these modern drinking fountains have proved their reputation for economy of operation, freedom from contamination and trouble-proof service over the years. Get our latest literature.

**THE HALSEY W. TAYLOR CO., WARREN, OHIO**

West Coast Plant  
Redlands, Calif.



**HALSEY TAYLOR**  
DRINKING FOUNTAINS



A-51

# A. I. A.

American Institute



# ACTIVITIES

of Architects

- Arizona Chapter:  
James Macmillan, President; Arthur T. Brown, Secretary, 740 N. Country Club Road, Tucson, Arizona.
- Central Valley of California:  
Herbert E. Goodpastor, President; Frank V. Mayo, Secretary, 307 Exchange Building, Stockton 2, California.
- Colorado Chapter:  
Raymond H. Ervin, President; James M. Hunter, Secretary, 2049 Broadway, Boulder, Colorado.
- Montana Chapter:  
Ralph H. Cushing, President; H. C. Cheever, Secretary, Montana State College, Bozeman, Montana.
- Northern California Chapter:  
Hervey P. Clark, President; Lester Hurd, Vice-President; Ralph Pollack, Secretary; William C. Ambrose, Treasurer; 605 Market Street, San Francisco.
- Oregon Chapter:  
Francis Jacobberger, President; J. D. Annand, Secretary, 401 Central Building, Portland 5, Oregon.
- San Diego Chapter (California):  
H. Louis Bodmer, President; Louis J. Gill, Secretary, 203 Granger Building, San Diego, California.
- Santa Barbara Chapter (California):  
Roy C. Wilson, President; Miss Lutah M. Riggs, Secretary, 240 Middle Road, Santa Barbara, California.

## CALIFORNIA COUNCIL OF ARCHITECTS

- John S. Bolles, President; Charles O. Matcham, Vice-President; James H. Mitchell, Secretary-Treasurer; 369 Pine Street, San Francisco 4.
- Southern California Chapter:  
Charles O. Matcham, President; John Landon, Secretary, Chapter Headquarters 3757 Wilshire Blvd., Los Angeles 5, California.
- Spokane Chapter (Washington):  
Noel E. Thomson, President; Kenneth D. Stormont, Secretary, Hutton Building, Spokane, Washington.
- Utah Chapter:  
George Cannon Young, President; Theodore R. Pope, Secretary, 29 South State Street, Salt Lake City 1, Utah.
- Washington State Chapter:  
George W. Stoddard, President; Stephen H. Richardson, Secretary, 516 Central Bank Building, Seattle 4, Washington.
- Hawaii Chapter:  
Kenneth W. Roehrig, President; James Morrison, Secretary, 334 Federal Bldg., Honolulu, T. H.

## NORTHERN CALIFORNIA CHAPTER, AIA

The Northern California Chapter of the AIA elected a panel of new officers for 1947 at a recently held meeting.

They are:

President .....Hervey P. Clark  
Vice-President .....Lester Hurd  
Secretary .....Ralph Pollack  
Treasurer .....William C. Ambrose

Also elected were two new directors—Wilbur Peugh and A. Lewis Koue, with William Knowles as a holdover director. Delegates chosen to represent the chapter on the California Council of Architects were John S. Bolles, Norman Blanchard, and Andrew T. Haas.

## SOUTHERN CALIFORNIA CHAPTER, AIA

The Honor Awards Program sponsored by the chapter posed definite and unusual problems for the jury. According to the terms of the program, designs are either accepted for an award, or not.

Practically every premiated design was visited, and the jury came to the conclusion that the basis of premiation should be an attempt to define representative desirable trends in contemporary architecture.

Then the question arose: what are representative desirable trends? And what projects demonstrate them the best?

The jury also had to consider the fact that attempts to strip itself of all prejudices results in the stripping of all critical faculties. Complete freedom from prejudice can only result in inability to make a decision.

The jury, therefore, had prejudices. It was the hope of the members that their prejudices would reflect the forward movement in architectural thinking and experience.

When a project, often good of its kind, would have required explanation to justify its position in a group representing contemporary trends, it was rejected for award.

No doubt such projects would have received high awards before any qualified jury, say about 1930. But these are new days. Architecture, for the purpose of this program, is a living art.

While we draw from history in long measure, still history is not the business of architecture.

The jury found that there was a group of projects that had not quite "arrived," but nevertheless represented in a high degree desirable trends.

The Creditable Mention Group was designed as a means of giving recognition to projects in this category.

Only time will reveal whether or not the jury's opinion coincides with the opinion of tomorrow. No attempt was made to guess what the architecture of the future will be like.

(Excerpts from report of jury, Honor Awards Program, 1938-1946. Submitted by: Pietro Belluschi, Ernest Born, John Root, Chairman.)

## HONOR AWARD WINNERS

The winners of the Honor Awards Program were divided into three groups: distinguished honor awards, honor awards, and creditable mention.

Richard Neutra and Reginald D. Johnson in collaboration with Wilson, Merrill and Alexander received Distinguished Honor Awards, Neutra for

(Continued on Page 34)

# WITH THE ENGINEERS

Structural Engineers Association of Northern California

William W. Moore, President; John A. Blume, Vice President; Franklin P. Ulrich, Sec.-Treas.; Offices 214 Old Mint Bldg., San Francisco, Phone GARfield 3890. DIRECTORS, Mark Falk, M. V. Pregnoff, and R. D. Dewell.

American Society of Civil Engineers  
San Francisco Section

Theodore P. Dresser, Jr., President; Leon H. Nishikian and Sidney T. Harding, Vice Presidents; John E. Rinne, Secretary-Treasurer; 225 Bush St., San Francisco 20.

Puget Sound Council (Washington)  
Engineering & Technical Societies

R. E. Kistler, A. I. E. E., Chairman; A. L. Miller, A.S.C.E., Vice-Chairman; L. B. Cooper, A.S.M.E., Secretary; B. A. Travis, I.E.S., Treasurer; Offices, Seattle, Washington.

## CIVIL ENGINEERS MEET

The Los Angeles section of the American Society of Civil Engineers held a dinner meeting at the Los Angeles Athletic Club recently.

Sam Perkins, inspector of dams of the California State Division of Water Resources, spoke on "Phases of Dam Design."

## ENGINEERS IN WORLD CONFERENCE

American engineers will participate in a permanent World Engineering Conference, with head-

quarters in Paris, Clarence E. Davies, secretary of the American Society of Mechanical Engineers, disclosed at a recent New York meeting of the society.

"American engineers have a duty . . . to assume a position of world leadership," Mr. Davies said, "because of their accomplishments."

## NEW ENGINEERS

An additional ten men were granted Professional Engineering and Land Surveying licenses in the States of Washington and Oregon. They were: T. R. Hance, T. N. Hunt, both of Spokane; R. G. Littler, O. J. Mithog, and H. C. Singleton, of Portland; A. G. Love, P. A. Piper, and C. E. Putnam, of Seattle; L. B. Almy, of Pullman; and R. S. Christman, of Renton.

## STUDIO ENGINEER SPEAKS

The Southern California chapter of the American Society of Heating and Ventilating Engineers held a dinner meeting recently in Los Angeles, at which John L. Blake, chief engineer, Metro-Goldwyn-Mayer Studios, spoke on: "Maintenance and Operation of Heating, Ventilating and Air-Conditioning in Metro-Golden-Mayer Studios."

## AWARD TO U. C. MAN

J. W. Kelly, associate professor of civil engineering at the University of California at Berkeley, has been awarded the American Construction Practice Award of the American Concrete Institute.

Professor Kelly received the award with B. D. Keatts, of Cleveland, Ohio, for a technical paper on two special methods of restoring and strengthening masonry structures.

## HIGHER STANDARDS

The nation's civil engineers, through their publication, "Civil Engineering," are advocating the accrediting of their employers, as a means of maintaining and raising the standards of the profession.

Frederick H. McDonald, writing in the January issue, predicts that: "With the recognition of accredited employers, those who are unaccredited would suffer the stigma now attached to unaccredited colleges."

The American Society of Civil Engineers, which sponsors the magazine, is also currently proposing a labor policy which recognizes the principle of collective bargaining, but asks freedom for professional men to form bargaining units comprised exclusively of professional men, and only when they choose to do so. The society will present its program to Congress when hearings are held on changing the country's labor laws.

**FOR BETTER SERVICE**

*Remember that*

**KRAFTILE is  
WESTERN HEADQUARTERS  
FOR**

- ◆ ACID Brick
- ◆ ACID-PROOF Jointing Compounds
- ◆ ACID-PROOF Floor and Tank Construction
- ◆ ACID-PROOF Coatings
- ◆ GLAZED Structural Wall Units
- ◆ PATIO Tile
- ◆ QUARRY Tile
- ◆ SWIMMING POOL Overflow Gutter



- ◆ QUONSET Packaged Steel Buildings
- ◆ STRAN-STEEL Framing

For complete information and prompt service, phone or write

**KRAFTILE COMPANY**

NILES, CALIFORNIA NILES 3611  
SAN FRANCISCO: 50 Hawthorne Street — DOUGLAS 3780  
LOS ANGELES: 316 E. Commercial Street — MUTUAL 2411

## FAVOR LICENSING OF ENGINEERS

The Puget Sound Council of Engineering and Technical Societies went on record recently in Seattle as favoring the registration and licensing of chemical engineers under state law.

## NEW POST

A Gordon Lorimer, Chief of the Bureau of Architecture, Department of Public Works, New York City, has been named technical consultant to the Producers' Council, national organization of building products manufacturers.

Lorimer supervised the design of New York City's vast postwar building program, running into hundreds of millions.

In his new post he will coordinate the Council's research and technical activities and supervise the design of industry-engineered homes being developed jointly by the Council and the National Retail Lumber Dealers Association.

## AERIAL PHOTOGRAPHY

Aerial photography is speeding up the work of locating routes for expressways, parkways and other routes needed to relieve postwar congestion, it was disclosed at a recent technical session of the American Society of Civil Engineers.

This streamlined pathfinding method is doing the job better and costs only a fraction of what ground surveys would cost, the engineers learned.

## JOINT MEETING

Highway officials of various states and highway contractors met recently in Philadelphia, Pa., to discuss their mutual interests.

The principal points under discussion included: the need for continuing highway programs in all states to enable contractors to maintain a high degree of efficiency, the urgency of reducing costs of operation through competition and more stable business conditions, and the need for increased pay for engineering and administrative staffs of state highway departments.

## UTAH PREPARES

Extensive preparations for the welcoming of new industries are being made by the State of Utah, according to that state's Department of Publicity and Industrial Development.

The continued operation of the Geneva Steel plant by the United States Steel Corporation is expected to attract numerous fabricating industries to process the material.

A general decentralization of industry from congested centers resulting from fear of atomic war is also anticipated, and Utah is getting ready to receive its share of the migration.

# How to make clients your friends

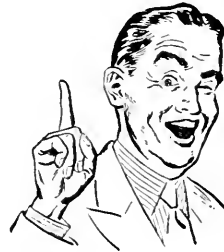

If you consider your clients' comfort and convenience for years to come, your clients will be friends for years to come. And one sure way is to plan for built-in telephone outlets before construction starts. Here's why!



Built-in telephone outlets add little to building costs...much to building value.

The location of the telephone can be changed or additional telephones may be added in the future without tearing up the flooring or running wires along baseboards.



The convenience of well placed telephone outlets will be appreciated now and for years to come.

*Call or dial local Telephone Business Office.  
Ask for Architects' and Builders' Service.*

## The Pacific Telephone and Telegraph Co.





Job—Oriental Rug Co., Vernon, Calif. • Engineers—Mackintosh & Mackintosh • Contractors—Contracting Engineers Co. • Truss Construction—American Bowstring, 40' span, 9 trusses, 17' apart

## ***Efficient Design*** **RAPID INSTALLATION**

No "fuss or feathers" to this, a typical American Roof Truss installation. The installation crew pulls up on the appointed day . . . a few hours later the entire truss system—a system designed to accommodate seismic stresses and other conditions is installed.

Ready now are American's complete western facilities, its quarter century background and design and installation of **roof trusses exclusively**. Phone or write today.

Register now to receive your copy of valuable Roof Truss data, soon off the press.



## **A. I. A. ACTIVITIES**

(Continued from Page 31)

his John Nesbitt residence, and the latter for their Baldwin Hills Village.

Honor Awards winners were:

Sumner Spaulding, John Rex and C. Gordon Deswarte for their George Behrendt residence.

Sumner Spaulding, John Rex and C. Gordon Deswarte for their guest house and farmers cottage for Rudolph Leibig.

Richard J. Neutra for his Kelton Apartments.

Sumner Spaulding, John Rex and C. Gordon Deswarte for their Frederick Wellensick shop.

W. L. Pereira, architect, and Wurdeman and Becket, associate architects, for their Pan-Pacific Theater.

Douglas Honnold, architect, and John Lautner, associate, for their Embassy Shop. They received a second award for their Beverly Hills Club.

Eugene Weston, Jr., and Walter L. Reichardt for their Community Facilities Building at Cabrillo Homes Housing Project.

W. L. Pereira for his Motion Picture Country House for Motion Picture Relief Fund.

Marsh, Smith and Powell for their Suva Street School for the Montebello Unified School District.

Richard J. Neutra, with Lewis E. Wilson as consultant, for their Channel House Housing Project.

The architects whose work qualified them for creditable mention were:

Whitney R. Smith for his Lee Zwell residence.

Walter Wurdeman and Weldton D. Becket for their Tilford's Restaurant.

Ralph C. Flewelling for design of his own office.

Paul Robinson Hunter for Nursery of Children's Home Society of California.

Paul Hunter and Walter Reichardt for their Horticulture Research buildings for University of California at Los Angeles.

Marsh, Smith and Powell for their George Bush Memorial Garden for South Pasadena Marino High School District.

Whitney R. Smith and Earl Gilbertson for their Linda Vista, a Shopping District for National Housing Authority.

The Honor Awards Exhibit can be viewed at the Los Angeles County Museum for a limited time during February.

### **GIVES THANKS**

The retiring president of the chapter, Charles O. Matcham, was accorded recognition for his services by a vote of thanks from the members.

### **SAN DIEGO CHAPTER, AIA**

New officers for 1947 were elected by the Chapter as a recent meeting. They are: President, H. Louis Bodmer; Vice-President, Robert Bradt; Secretary, Louis J. Gill; Treasurer, Charles H. Salyers.



The appointment of Louis J. Gill to serve on the National Board for Accrediting Architectural Schools, which has been set up by the American Institute of Architects, has been announced. This board maintains a list of schools which the state architectural licensing boards recognize as giving proper training for the practice of architecture.

#### WASHINGTON STATE CHAPTER, AIA

Joshua Vogel, planning consultant of the bureau of public administration, University of Washington, has been asked to prepare a new or revised building code for hospitals in the state.

The chapter's committee on architect and government relations, of which Vogel is chairman and Frances E. Huggard secretary, will undertake the work. Mechanical and electrical engineers, particularly Lincoln Bouillon, C. W. May, Carl Anderson, and architects Perry Johanson and John Maloney are being asked to participate.

Other members of the committee are: Priteca, Stewart, Osterman, Woleb and Pearson. Members of the chapter who have model standards for hospitals which are not likely to be included in the committee's library of information are asked to lend them to the committee.

#### FELLOWSHIP

A. B. Drought, young British architect, has received one of the twenty Commonwealth Fund Fellowships, which were established to enable selected graduates of British Universities to study and travel in the United States. He was the only architect chosen.

The Fellowships have an approximate value of \$3,500 and are being resumed after wartime suspension. Drought will do postgraduate work at the Massachusetts Institute of Technology.

#### EXTENSION COURSES OFFERED BY U. C.

Among the general courses being offered by the University of California Extension is "Appreciation of Architecture," which opened on January 22nd, at 540 Powell, San Francisco.

Other courses include: "Applied Differential Equations for Engineers and Chemists," "Electrical Circuits and Machines," "Radio Engineering," "Earthquake-Resistant Design," and "Industrial Electronics."

#### VETERAN APPRAISALS

The Veterans' Administration has recently tightened up on the appraisal procedure covering home loans to veterans. Although the G. I. Bill provides for 100% financing on veterans' home purchases, many lending institutions are now demanding a 10% down payment, largely as a result of the VA's action.



## THOMAS A. EDISON

1847      CENTENNIAL      1947

In fitting recognition of the genius of Thomas A. Edison, the nation joins on February 11 in a Centennial to mark the 100th birthday anniversary of this great American.

The world owes an unpayable debt to Edison for his many inventions and scientific discoveries. His talents covered many fields. He made the first electric light; invented the transmitter that made the telephone practical; patented hundreds of meters, switches, conduits, sockets and similar appurtenances, and perfected an entire system for the distribution of electric power . . . thus laying the foundation for modern living.

The homes you design today reflect his genius as you provide for the full enjoyment and conveniences of electricity.

NORTHERN CALIFORNIA  
ELECTRICAL BUREAU

1355 Market Street  
San Francisco 3

# BAXCO

CHROMATED ZINC CHLORIDE

# CZC

**PRESSURE TREATED LUMBER**  
● **PROTECTS AGAINST DECAY**  
**AND TERMITE ATTACK**

*Specify it in your home*  
*Available through Lumber Dealers*

LOS ANGELES                      SAN FRANCISCO  
601 W. 5th Street                  333 Montgomery Street  
Phone Mlchigan 6294              Phone DOuglas 3883

## J. H. Baxter & Co.

AGENTS FOR WEST COAST WOOD PRESERVING CO. SEATTLE, WASH.



### LOS ANGELES

*Branch Offices*

HOLLYWOOD                      SIERRA MADRE                      UPLAND  
PASADENA                      TEMPLE CITY                      LA VERNE  
LONG BEACH                      WHITTIER                      SAN PEDRO  
RIVERSIDE                      ONTARIO                      INDIO

### OAKLAND

### SAN FRANCISCO

## HEADLINE NEWS & VIEWS

By E. H. W.

Acquisition of additional manufacturing facilities on the Pacific Coast by Columbia Steel will enable this already rapidly expanding West Coast company to offer a more complete service to architects, engineers, and contractors.

### DILEMMA

Our limited progress in understanding numerous Consumers' price indexes, Bureau of Labor Statistics, and National Industrial Conference Board reports, has been completely retarded by the Nathan-CIO statements. As Joe Doaks might explain the situation, "We don't know from nothing."

### WONDER WHAT THE VETERAN THINKS?

Since V-J Day we have read a considerable amount of propoganda, most of which emanated from governmental sources, relating to the Veterans' Housing Program. This reading material has covered about every phase of home construction; from the buying of the lot, the driving of the first nail, and the financing.

One very important factor has been missing, however, and that is what do the Veterans think of current "housing."

If some "official" spokesman for the Veterans has prepared some material dealing with this subject, we would enjoy reading it.

The Federal Airport Act authorizes the appropriation of \$500,000,000 in Federal funds to be matched by local sponsors for a seven year airport construction program. Numerous cities and counties have already instituted plans for local airport development under the Federal plan.

REMOVAL OF PRICE CONTROLS places the responsibility of meeting the Nation's building needs squarely up to the construction industry. A situation much more satisfactory than under government controls.

### PREDICTS TILE PRICE CHANGE UNLIKELY

Charles H. Burchenal, chairman of the Tile Council of America, has announced that "Tile manufacturers in general have indicated that ceramic tile prices will run fairly close to ceilings established by OPA during the past six months."

Exception may be plants which were unable to secure price adjustments under OPA prior to removal of price restrictions.

## IN THE NEWS

### JUNIOR COLLEGE EXPANDS

The San Francisco Junior College is taking bids for the construction of additional horticultural facilities, including greenhouses, to cost \$50,000. Milton Pflueger, San Francisco, is the architect.

### DOCTORS' OFFICE BUILDING

A doctors' office building to cost \$30,000 will soon be constructed at Capitol & 27th Sts., Sacramento, California. The architects are Berovetto & Thomas of Sacramento. The building will be of masonry and Monterey Stone and frame construction.

### FLEXIBLE PIPING

The ESCO P-T ADAPTER permits incorporation of stainless steel tubing in lighter take-off systems from standard piping layouts.

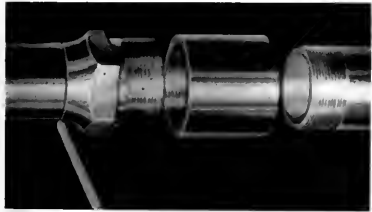

Manufactured by the Electric Steel Foundry of Portland, Oregon, the new-type fitting overcomes difficulty encountered in putting pipe and tubing together in easily assembled joint. The tubing is butt-welded to the adapter and becomes permanent pipe, readily assembled or dismantled for cleaning or inspection.

### ARCHITECT SELECTED

Albert F. Roller of San Francisco has been selected as the architect for the \$1,000,000 factory building and office addition to be constructed at Emeryville, Calif., by the Marchant Calculating Machine Company.

### TOOL ENGINEERS TO MEET

Some 2500 tool engineers are expected to attend the annual convention of the American Society of Tool Engineers, to be held at Houston, Texas, March 19-22.

# WESTERN MADE



## Quality LIGHTING FIXTURES

The West supports one of America's leading manufacturers of lighting equipment... producing quality fixtures bearing a nationally known label. With production concentrated on the Pacific Coast, Smoot-Holman Co. assures western users a dependable source of supply for all types of commercial and industrial incandescent and fluorescent lighting.

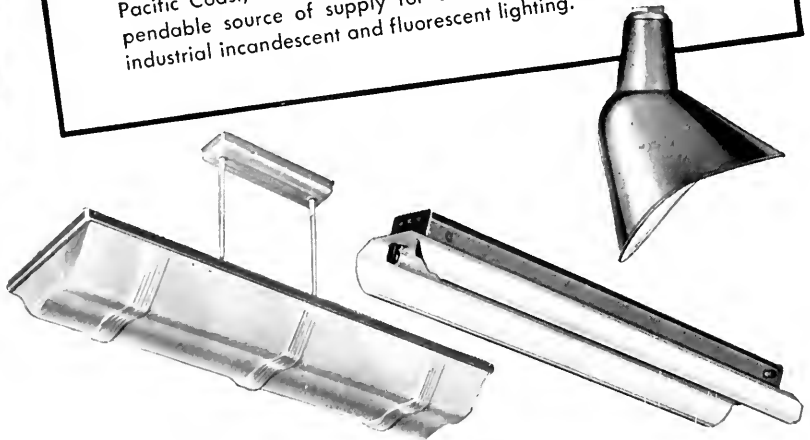

LOOK FOR THIS LABEL FOR THE FINEST IN  
INCANDESCENT AND FLUORESCENT LIGHTING

## IN THE NEWS

### ARCHITECTS CHOSEN

Myron Hunt and H. C. Chambers are the architects of the new dormitory for women to be constructed at Los Angeles by the University of California.

Of modified Mediterranean design, the building will consist of two separate housing units joined by a central administrative unit. It will accommodate 231 women.

### NEW WEST COAST INDUSTRY

The American Roof Truss Company, manufacturer of wood trusses, has joined the ranks of industries coming West with the completion of a plant in Los Angeles. The company's office is in Chicago.

William H. Waddington, Jr., vice-president, is in charge of all Western operations. He stated that West Coast materials and labor would be used exclusively to insure prompt deliveries.



W. H. WADDINGTON, JR.  
Vice-President

"California building codes present a somewhat different problem from those met in the Middle West and East," Waddington explained, "but we feel that our extensive nation-wide experience of over a quarter of a century enables us to fuse the best of time-tested methods with the West's strong trend toward functional design."

### EIGHT BILLION

A non-housing construction program of \$8,500,000,000 is possible for 1947 without in the least interfering with home building, if all limitations are removed, according to a recent statement by Douglas Whitlock, chairman of the Building Products Institute.

"Production of brick and many other basic materials is already well in excess of housing needs and may have to be cut back if limitations on non-housing are held too low," he said.

### REVISED SPECIFICATIONS FOR GRADES OF REDWOOD LUMBER

After many months of study the grading committee of the California Redwood Association have announced revised specifications for grades of California redwood lumber.

The revised yard grades include three heart-

wood grades, clear All Heart Redwood, the highest quality finish grade is retained. Select Heart and Construction Heart are for contact with the soil.

Yard grades containing sapwood are A-Grade; Utility, made in one-inch thickness only; Sap Common for general construction; and No. 3 Common.

Special purpose grades such as Foundation Grade, Irrigation Heart, Dense Structural, Shop, Tank Stock, Expansion Joint Redwood and Ties have been retained. Rules also include lath, shingles and shakes.

### WESTERN AIRPORTS

The Civil Aeronautics Authority has announced its airport program for 1947, under which the Western states fare as follows: California gets 33 projects; Colorado, 9; Idaho, 45; Arizona, 9; New Mexico, 10; Oregon, 32; Washington, 16; Utah, 17; Wyoming, 3; Montana, 46; and Nevada, 1.

CAA also announced revised rules and regulations governing allocation of funds under the National Airport Aid Act, with larger municipalities obtaining a greater portion of Federal funds. Sponsors of Class 4 and 5 airports will be eligible to receive up to 50 per cent of cost on projects up to \$5,000,000, instead of the previous maximum of \$2,000,000.

The minimum Federal contribution will be 20 per cent, with all allocations on a matching basis.

### PRODUCERS' COUNCIL

New high records in the output of all building materials will be achieved in 1947 unless production is hindered by shortages of raw materials or strikes, Tyler S. Rogers, president of the Producers' Council, stated recently.

"Many manufacturers will need additional plant facilities and record quantities of raw materials to keep pace with the high demands of the future," Rogers said.

The head of the Producers' Council also believes that increases in the prices of building materials since the removal of price ceilings, averaging about 15%, are mostly temporary, having been brought about by interrupted supplies, uncertainty as to wage levels, and the low productivity and inexperience of new workers.

"As these abnormal conditions disappear," Rogers continued, "competition between manufacturers of similar products will force prices down."

### NORTHERN CALIFORNIA EXPANDS

Industrial expansions in Northern California totalled \$130,600,000 for the first 11 months of 1946, the San Francisco Chamber of Commerce recently reported. This figure compares with \$126,450,000 for the same period of 1945.

The 1946 total includes 672 new plants and 493 expansions of existing plants, while for the 1945 period there were 398 new plants and 314 expansions. The term "Nothern California" takes in 48 counties for these tabulations.

### ILLUMINATORS MEET

The Illuminating Engineering Society, Pacific Northwest Region, held a recent regional conference in Seattle which brought together several nationally-known authorities in the lighting field.

Among the topics discussed were such subjects as: Studies of Illumination Brightness in Residential Interiors, New Developments in Mercury Lamps, Merchandising Lighting Design, Practical Factors Affecting Illumination Design for Merchandising Areas, and the Application and Characteristics of Flash Tubes.

### WESTERN PROSPECTS

A recent report of the California State Reconstruction and Reemployment Commission states there are three types of industrial development possible for the Western States in the postwar era. They are, in brief:

1. Industries making products with unique local and regional markets, which in some cases have possibilities of sale in other areas against national competition.

2. Industries in which freight cost and other advantages permit regional competition but do not provide sufficient profit to induce out-of-region firms to enter the market.

3. Industries so highly dominated by national firms that regional production can only occur primarily through branch plants of these national firms.

### TALKS ON ATOMIC ENERGY

Charles P. Cabell, chemical engineer at the Hanford Engineer Works of the General Electric Company at Richmond, Washington, addressed a recent meeting of the San Francisco chapter, American Society of Civil Engineers, on the subject, "Atomic Energy For Power Generation."

The engineering aspects of obtaining energy by nuclear fission were outlined by Cabell and illustrated with slides.

### GOOD HARDWARE

Good hardware is an economy for the home builder and owner, says the Small Homes Council of the University of Illinois.

"Cheap hardware is a poor investment," the council maintains in its publication "Hardware For the Home," recently issued. "It soon depreciates in appearance, and costs more in repairs and replacements. The difference in cost between

good and second-rate hardware is generally less than \$25 for the average small home."

The factor of security involved in locksets is also to be considered, the publication pointed out.

### REAL ESTATE BONDS

Bond issues of apartments, hotels, and office buildings are still at a nine-year high, despite a recent dip.

### DETENTION HOME

Bids are being taken on the \$175,000 county detention home to be built in Sacramento County, Harry J. Devine, Sacramento, architect.

## FORDERER CORNICE WORKS

*Manufacturers of*

Hollow Metal Products • Interior Metal Trim  
Elevator Fronts and Cabs  
Metal Plaster Accessories • Sanitary Metal Base  
Flat and Roll Metal Screens  
Metal Cabinets • Commercial Refrigerators

**269 POTRERO AVE.**

**SAN FRANCISCO, CALIF.**

**HEMLOCK 4100**

## STRUCTURAL STEEL

For Class A Buildings,  
Bridges, etc.

**JUDSON PACIFIC - MURPHY CORP.**

1200 SEVENTEENTH STREET  
SAN FRANCISCO

Plants: San Francisco - Oakland

# SISALKRAFT

REG. U. S. PAT. OFF.

*"More than a building paper"*

**THE SISALKRAFT CO.**

205 West Wacker Drive  
Chicago, Ill.

55 New Montgomery Street  
San Francisco, Calif.

## COMPLETED UNITS WILL EQUAL ESTIMATED BUILDING SCHEDULE

Production of building materials during the remainder of the year should be sufficient to enable builders to complete all conventional and prefabrication type homes started but not finished during the last half of the year and to permit the starting of several hundred thousand additional units, Douglas Whitlock, chairman of the Advisory Board of the Producers' Council predicts. Mr. Whitlock said:

"Production of most scarce items is increasing gradually, although continuing shortages of steel and copper and other raw materials have been holding down the rate of increase.

"The trend of production during the next few months will depend in large part on the speed with which the new pricing formulas stipulated by Congress are put into effect.

"The regrettable fact that only about 40,000 of the new conventional type and prefabricated homes started during the first half of the year were completed by mid-year, as disclosed in a recent report, is due to confusion and delay on the part of the Federal government during that period.

"The OPA's decision to withhold badly needed ceiling price increases on low-cost materials prevented the starting and completion of thousands of homes and has more than doubled the length of

time required to complete the average dwelling unit.

"The output of many scarce building products has been only about half to two-thirds as great as it might have been had the OPA and other interested Federal agencies acted promptly to remove the pricing bottlenecks which they belatedly recognized and eliminated and to assist manufacturers in obtaining housing needed for additional workers.

"If the Housing Expediter and the OPA are able to speed up production of scarce raw materials needed in the manufacture of building products and if no new labor difficulties arise, materials shortages should cease to be a bottleneck in home building by the middle of the year."

## OIL PRODUCTION INCREASES

The U. S. oil industry produced 61% of the world output in 1945, which totaled 2,800,000,000 barrels. World output has doubled since 1930, largely accelerated by war needs.

## PEACETIME ELECTRONICS

Industrial electronic devices now number over 16,000, and are used by 796 companies, a recent survey showed. The electronics industry now turns out \$1,000,000,000 in products annually, as against a wartime peak of over \$4,000,000,000, but peacetime applications are on the increase. Electronics products turned out in 1941 had a value of \$300,000,000, indicating that the industry has expanded three times on a peacetime basis.

Principal uses include: heating, control, power conversion, counting, sorting, weighing, inspecting, molecular vibration uses, measurement, analysis, and safety.

## COSTS SOAR

One reason why the cost of building materials has soared: U. S. Dept. of Labor reports southern pine production requires 34 per cent more labor than it did in 1935. Lack of skilled men plus the fact that smaller trees are being cut today explains one of the reductions in man-power efficiency.

## HOME FREEZER

A new, drawer-type freezer, the "Freez-All," has been developed as an answer to the homemaker's food freezer problem.

This freezer, with 8 cubic feet of accessible storage space, has three large food storage drawers that open "at the touch of a finger." These drawers, with a capacity of 400 pounds of frozen foods, mounted on ball bearing rollers, bring the food out where it can be seen and reached. Meats, vegetables and fruits are separated.

# VALUABLE NEWS SERVICE

- BUILDING MATERIAL DEALERS
- CONTRACTORS
- ENGINEERS
- FINANCIAL INSTITUTIONS

**ARCHITECTS REPORTS** gives advance news on construction projects in Northern California, lists: name of projects, location, architect, proposed cost and other pertinent information.

**HANDY** individual slip-reports, issued daily at a total cost of only

\$10 a month

# ARCHITECT'S REPORTS

Published Daily

The ARCHITECT and ENGINEER, Inc.

68 Post Street, San Francisco - DO 8311

# ESTIMATOR'S GUIDE

## BUILDING AND CONSTRUCTION MATERIALS

PRICES GIVEN ARE FIGURING PRICES AND ARE MADE UP FROM AVERAGE QUOTATIONS FURNISHED BY MATERIAL HOUSES TO SAN FRANCISCO CONTRACTORS. 2 1/2% SALES TAX ON ALL MATERIALS BUT NOT LABOR

All prices and wages quoted are for San Francisco and the Bay District. There may be slight fluctuation of prices in the interior and southern part of the state. Freight cartage, at least, must be added in figuring country work.

**BONDS**—Performance—\$10 per \$1000 of contract. Labor and materials, \$10 per \$1000 of contract.

**BRICKWORK**—

- Common Brick—Per IM laid—\$80.00 to \$100.00 (according to class of work).
- Face Brick—Per IM laid—\$150 to \$200 (according to class of work).
- Brick Steps—\$2.30 per lin. ft.
- Brick Veneer on Frame Bldg.—Approx. \$1.50 per sq. ft.
- Common Brick—\$26.00 per M, truckload lots, f.o.b. job.
- Face Brick—\$60 to \$100 per M, truckload lots, delivered.
- Cartage—Approx. \$5.00 per M.

**BUILDING PAPER**—

- 1 ply per 1000 ft. roll ..... \$5.30
- 2 ply per 1000 ft. roll..... 7.80
- 3 ply per 1000 ft. roll..... 9.70
- Browskin, Standard, 500 ft. roll. .... 7.00

**BUILDING HARDWARE**—

- Sash cord com. No. 7..... \$2.50 per 100 ft.
- Sash cord com. No. 8..... 2.75 per 100 ft.
- Sash cord spot No. 7..... 3.50 per 100 ft.
- Sash cord spot No. 8..... 3.75 per 100 ft.
- Sash weights, cast iron, 550.00 ton.
- Nails, \$3.42 base.
- Sash weights, \$45.00 per ton.

**CONCRETE AGGREGATES**—

The following prices net to Contractors unless otherwise shown. Carload lots only.

	Bunker per ton	Del'd per ton
Gravel, all sizes .....	\$2.44	\$2.15
Top Sand .....	2.38	3.13
Concrete Mix .....	2.38	3.06
Crushed Rock, 1/4" to 3/4".....	2.38	2.94

	Bunker per ton	Del'd per ton
Crushed Rock, 3/4" to 1 1/2".....	\$2.38	\$3.13
Roofing Gravel .....	2.81	3.50
River Sand .....	2.50	3.06

**Sand**—

Lapis (Nos. 2 & 4) .....	3.56	3.94
Olympia (Nos. 1 & 2) .....	3.56	3.88

**Cement**—

Common (all brands, paper sacks), carload lots, \$3.02 per bbl. f.o.b. car; delivered \$3.40. Cash discount on carload lots, 10c a bbl., 10th Prox., less than carload lots \$4.00 per bbl. f.o.b. warehouse or delivered. Cash discount 2% on L.C.L.

Atlas White { 1 to 100 sacks, \$3.13 sack  
Calaveras White { warehouse or del.; \$9.56  
Medusa White { bbl. carload lots.

**DAMP-PROOFING and Waterproofing**—

- Two-coat work, \$5.00 per square.
- Membrane waterproofing—4 layers of saturated felt, \$9.00 per square.
- Hot coating work, \$3.00 per square.
- Medusa Waterproofing, \$3.50 per lb. San Francisco Warehouse.
- Tricocel waterproofing.  
(See representative.)

**ELECTRIC WIRING**—\$15 to \$20 per outlet for conduit work (including switches).

Knob and tube average \$6.00 per outlet. (Available only for priority work.)

**ELEVATORS**—

Prices vary according to capacity, speed and type. Consult elevator companies. Average cost of installing a slow speed automatic passenger elevator in small four story apartment building, including entrance doors, about \$8000.00.

**EXCAVATION**—

- Sand, \$1.00; clay or shale, \$1.50 per yard.
- Trucks, \$30 to \$45 per day.
- Above figures are an average without water. Steam shovel work in large quantities, less; hard material, such as rock, will run considerably more.

**FIRE ESCAPES**—

Ten-foot galvanized iron balcony, with stairs, \$250 installed on new buildings; \$300 on old buildings.

**FLOORS**—

- Composition Floors, such as Magnesite, 50c per square foot.
- Linoflor—2 gages—\$3.00 per sq. yd.
- Mastipave—\$1.50 per sq. yd.
- Battleship Linoleum—available to Army and Navy only—1/8"—\$3.50 sq. yd.  
3/16"—\$3.50 sq. yd.
- Terazzo Floors—\$1.50 per sq. ft.
- Terazzo Steps—\$2.50 per lin. ft.
- Mastic Wear Coat—according to type—20c to 35c.

**Hardwood Flooring**—

- Standard Mill grades not available.
- Victory Oak—T & G  
3/4" x 2 1/4" ..... \$252.00 per M. plus Cartage  
1/2" x 2" ..... \$210.00  
1/2" x 1 1/2" ..... 200.00
- Prefinished Standard & Better Oak Flooring  
3/4" x 3 1/4" ..... \$265.00 per M. plus Cartage  
1/2" x 2 1/2" ..... 237.00 per M. plus Cartage
- Maple Flooring  
3/4" T & G Clear ..... \$330.00 per M. plus Ctg.  
2nd ..... 305.00 per M. plus Ctg.  
3rd ..... 255.00 per M. plus Ctg.
- Floor Layers' Wage, \$1.87 1/2 per hr. (Legal as of Jan. 21, 1946. Given us by Inlaid Floor Co.)

**GLASS**—

- Single Strength Window Glass ..... \$ .40 per sq. ft.
- Double Strength Window Glass ..... .60 per sq. ft.
- Plate Glass, under 75 sq. ft. .... 1.25 per sq. ft.
- Polished Wire Plate Glass ..... 2.10 per sq. ft.
- Rgh. Wire Glass ..... .60 per sq. ft.
- Obscure Glass ..... .40 per sq. ft.
- Glazing of above is additional.
- Glass Blocks ..... \$2.75 per sq. ft. set in place

**HEATING**—

- Average, \$2.50 to \$3.00 per sq. ft. of radiation, according to conditions.
- Warm air (gravity) average \$64 per register.
- Forced air average \$91 per register.

**INSULATION AND WALLBOARD —**

Fiberglass Insulation—Full thickness 3 1/2" .....	\$79.00 per M sq. ft.
Cellulose Insulation—Full thickness (3 1/2" .....	\$95.50 per M sq. ft.
Aluminum Insulation—Foil-mounted with shingles .....	\$33.50 per M sq. ft.
Trip board—4'x6' panel .....	\$9.00 per panel
Wall board—1/2" thickness .....	\$49.50 per M sq. ft.
Finished Plank .....	\$69.00 per M sq. ft.
Ceiling Trip board .....	\$69.00 per M sq. ft.

**IRON**—Cost of ornamental iron, cast iron, depends on designs.

**LUMBER —**

No. 1 Common .....	\$90.00 per M
No. 2 Common .....	88.00 per M
Select O. P. Common .....	94.00 per M

**Flooring —**

V.G., D.F., B & Btr. 1 x 4 T & G Flooring	Per M Delvd. \$170.00
"C" and better—alt .....	170.00
"D" and better—alt .....	170.00
Rwd. Rustic—A grade, medium dry .....	150.00
"B" grade, medium dry .....	150.00
Plywood .....	15c to 18c per ft.
Pyscoro .....	9 1/2c per ft.
Plywall .....	9c per ft.
Plyform .....	15c per ft.

**Shingles (Rwd. not available) —**

Red Cedar No. 1—\$13.00 per square; No. 2, \$10.50; No. 3, \$9.00.  
Average cost to lay shingles, \$6.00 per square.  
Cedar Shakes—Tapered: 1/2" to 3/4" x 25"—\$17.00 per square.  
Resawn: 3/4" to 1 1/4" x 25"—\$22.00 per square  
Average cost to lay shakes,—8.00 per square

**MILLWORK —Standard.**

D. F. \$140 per 1000. R. W. Rustic \$150 per 1000 (delivered).  
Double hung box window frames, average with trim, \$10 and up, each.  
Complete door unit, \$14 to \$20.  
Screen doors, \$6.00 to \$8.00 each.  
Patent screen windows, 50c a sq. ft.  
Cases for kitchen pantries seven ft. high, per lineal ft., \$12.00 each.  
Dining room cases, \$12.00 per lineal foot.  
Rough and finish about \$1.00 per sq. ft.  
Labor—Rough carpentry, warehouse heavy framing (average), \$60.00 per M.  
For smaller work average, \$60.00 to \$75.00 per 1000.

**MARBLE —(See Dealers)**

**PAINTING —**

Two-coat work .....	per yard 60c
Three-coat work .....	per yard 80c
Cold water painting .....	per yard 25c
Whitewashing .....	per yard 15c

**PAINTS —**

Two-coat work .....	60c per sq. yd.
Three-coat work .....	80c per sq. yd.
Cold water painting .....	25c per sq. yd.
Whitewashing .....	15c per sq. yd.
Turpentine .....	\$1.85 per gal. in 5-gal. cont.
Raw Linseed Oil .....	\$3.19 per gal. in 5-gal. cont.

Boiled Linseed Oil .....
 \$2.50 per gal. in drums || Boiled Linseed Oil—\$2.90 per gal. in 5-gal. containers. |  |
Replacement Oil—\$2.56 per gal. in drums. \$2.56 per gal. in 5-gal. containers.	
Use Replacement Oil .....	\$2.69 per gal. in 1 gal. cont.
A deposit of \$7.50 required on all drums.	

**PATENT CHIMNEYS —**

6-inch .....	\$2.00 lineal foot
8-inch .....	2.50 lineal foot
10-inch .....	3.50 lineal foot
12-inch .....	4.50 lineal foot

**PLASTER —**

Neat wall, per ton delivered in S. F. in paper bags, \$17.60.

**PLASTERING (Interior) —**

3 Coats, metal lath and plaster .....	Yard \$3.00
Keene cement on metal lath .....	3.50
Ceilings with 3/4 hot roll channels metal lath (lathed only) .....	3.00
Ceilings with 3/4 hot roll channels metal lath plastered .....	4.50
Single partition 3/4 channel lath 1 side (lath only) .....	3.00
Single partition 3/4 channel lath 2 inches thick plastered .....	8.00
4-inch double partition 3/4 channel lath 2 sides (lath only) .....	5.75
4-inch double partition 3/4 channel lath 2 sides plastered .....	8.75
Thermax single partition; 1" channels; 2 1/4" overall partition width. Plastered both sides .....	7.50
Thermax double partition; 1" channels; 4 3/4" overall partition width. Plastered both sides .....	11.00
3 Coats over 1" Thermax nailed to one side wood studs or joists .....	4.50
3 Coats over 1" Thermax suspended to one side wood studs with spring sound isolation clip .....	5.00
Note—Channel lath controlled by limitation orders.	

**PLASTERING (Exterior) —**

2 coats cement finish, brick or concrete wall .....	Yard \$2.50
3 coats cement finish, No. 18 gauge wire mesh .....	3.50
Lime—\$4.00 per bbl. at yard.	
Processed L.L.Lime—\$4.15 per bbl. at yard.	
Rock or Grip Lath—3/8"—30c per sq. yd.	
1/4"—29c per sq. yd.	

Composition Stucco—\$4.00 sq. yard (applied).

**PLUMBING —**

From \$150.00 per fixture up, according to grade, quality and runs.

**ROOFING —**

"Standard" tar and gravel, 4 ply—\$11.00 per sq. for 30 sqs. or over.  
Less than 30 sqs. \$14.00 per sq.  
Tile \$40.00 to \$50.00 per square.  
Redwood Shingles, \$15.00 per square in place.  
5/2 # 1-16" Cedar Shingles, 4 1/2" Exposure .....
 \$16.50 square |

5/8 x 16"—#1 Cedar Shingles, 5" Exposure .....
 \$17.00 square || 4/2 # 1-24" Royal Shingles, 7 1/2" Exposure ..... | \$18.25 square |
Re-coat with Gravel .....	\$5.50 per sq.
Asbestos Shingles \$30 to \$60 per sq. laid.	
1/2 x 25" Resawn Cedar Shakes, 10" Exposure .....	\$18.50
3/4 x 25" Resawn Cedar Shakes, 10" Exposure .....	21.00
1 x 25" Resawn Cedar Shakes, 10" Exposure .....	22.00
Above prices are for shakes in place.	

**SHEET METAL —**

Windows—Metal, \$2.50 a sq. ft.  
Fire doors (average), including hardware \$2.80 per sq. ft.

**SKYLIGHTS —(not glazed)**

Copper, \$1.25 sq. ft. (flat).  
Galvanized iron, 65c sq. ft. (flat).  
Vented hip skylights 90c sq. ft.

**STEEL —STRUCTURAL —**

Base, delivered, \$3.06 per 100, plus normal extras; or \$300.00 to \$400.00 ton in place. Light truss work higher.

**STEEL REINFORCING —**

\$200.00 ton, set.

**STORE FRONTS (None available).**

**TILE —**

Ceramic Tile Floors—\$1.50 per sq. ft.  
Cove Base—\$1.25 per lin. ft.  
Glazed Tile Wainscot—\$1.50 per sq. ft.  
Asphalt Tile Floor 1/8" x 3/8"—.40 per sq. ft.  
Light shades slightly higher.  
Cork Tile—\$1.00 per sq. ft.  
Mosaic Floors—See dealers.  
Lino-Tile—\$1.00 per sq. ft.

**Wall Tile —**

Glazed Terra Cotta Wall Units (single faced) laid in place—approximate prices:

2 x 6 x 12 .....	\$1.25 sq. ft.
4 x 6 x 12 .....	1.50 sq. ft.
2 x 8 x 16 .....	1.45 sq. ft.
4 x 8 x 16 .....	1.75 sq. ft.

**VENETIAN BLINDS —**

85c per square foot and up. Installation extra.

**WINDOWS —STEEL —**

50c per square foot, \$5 for ventilators.



# IN THE NEWS

## BAY AREA CONSTRUCTION

Construction contracts for the San Francisco Bay Area added up to approximately \$277,000,000 for 1946, according to figures released by the San Francisco Chamber of Commerce.

It is estimated that there is a need for about 144,000 additional dwelling units in the nine counties of the Bay area. At an assumed average cost of \$7,000 there is a ready-made market for \$1,000,000,000 in residential construction alone.

A lightweight wall, made of plywood and aluminum, originally made for airplane floors, is now going into homes. Prefabrication marches on!

## AIRPORT TERMINALS

Airport terminal construction led the agenda at a recent dinner meeting of the Chicago chapter, American Institute of Architects.

A panel discussion, conducted by A. F. Heine,

United Air Lines architect, included such participants as Howard L. Cheney, designer of the Washington National airport terminal building; G. Meredith Musick of Denver, architect for the new terminal building at Denver, Colo.; and Henry R. Shepley, member of Coolidge, Shepley, Bullfinch & Abbot, of Boston, Mass., architects for the new airport terminal building there.

## BUILD TEXTILE PRINTING PLANT

A textile printing plant to cost \$156,000 is being constructed at Santa Clara, Calif., by the Bibb-Castle Corporation. Structural engineer on the project is W. D. Lotz of San Jose.

## OPENS OFFICE

Mario C. Gaidano, architect, announces the opening of offices at 177 Post St., Leibes Bldg., Room 80T, San Francisco, Calif. Manufacturers literature desired.

## WESTERN STEEL CONSUMPTION

A probable consumption of 3,700,000 tons of steel annually is estimated for the 11 Western

## BUILDING TRADES WAGE (JOB SITES) NORTHERN AND CENTRAL CALIFORNIA

ATTENTION: The following are the PREVAILING hourly rates of compensation as determined by the Wage Adjustment Board, or which have been determined by the United States Department of Labor—Revised to July 1, 1946. Wage scales shown are those being paid and in effect mostly by agreement between employees and their union.

CRAFT	San Francisco	Alameda and Contra Costa	Marin	Vallejo	San Mateo	San Jose	Stockton	Sacramento	Fresno
ASBESTOS WORKERS	1.75	1.75	1.75	1.75	1.75	1.75	1.75	1.75	1.75
BRICKLAYERS	2.05	2.05	2.05	2.05	2.05	2.05	1.75	2.05	2.00
BRICKLAYERS' HODCARRIERS	1.57½	1.57½	1.57½	1.57½	1.57½	1.57½	1.47½	1.15	1.25
CARPENTERS	1.75	1.75	1.75	1.75	1.75	1.62½	1.50	1.50	1.50
CEMENT FINISHERS	1.75	1.75	1.75	1.75	1.75	1.75	1.75	1.75	1.75
ELECTRICIANS	1.87½	1.87½	1.87½	1.70	1.87½	1.87½	1.75	1.82½	1.75
ENGINEERS: MATERIAL HOIST	1.60	1.60	1.60	1.60	1.60	1.60	1.60	1.60	1.60
PILE DRIVER	2.00	2.00	2.00	2.00	2.00	2.00	2.00	2.00	2.00
STRUCTURAL STEEL	2.00	2.00	2.00	2.00	2.00	2.00	2.00	2.00	2.00
GLASS WORKERS	1.58½	1.58½	1.58½	1.58½	1.58½	1.21	1.40	1.37½	1.37½
IRONWORKERS: ORNAMENTAL	1.85	1.85	1.85	1.85	1.85	1.85	1.85	1.85	1.85
REINF. RODMEN	1.75	1.75	1.75	1.75	1.75	1.75	1.75	1.75	1.75
STRUCTURAL	2.00	2.00	2.00	2.00	2.00	2.00	2.00	2.00	2.00
LABORERS: BUILDING & CONCRETE	1.25	1.25	1.15	1.15	1.15	1.15	1.25	1.25	1.15
LATHERS	1.90	1.90	1.60	1.87½	1.75	2.00	1.87½	1.60	1.87½
MARBLE SETTERS	1.75	1.75	1.75	1.75	1.75	1.75	1.75	1.75	1.75
MOSAIC & TERRAZZO	1.75	1.75	1.75	1.75	1.75	1.75	1.60	1.16	1.12½
PAINTERS	1.75	1.75	1.75	1.64	1.75	1.75	1.60	1.60	1.50
PILEDRIVERS	1.86	1.86	1.86	1.86	1.86	1.86	1.86	1.86	1.86
PLASTERERS	2.00	2.00	1.75	2.00	2.05	2.00	2.00	1.87½	1.87½
PLASTERERS' HODCARRIERS	1.75	1.75	1.75	1.75	1.75	1.75	1.65	1.65	1.40
PLUMBERS	1.87½	1.87½	1.87½	1.87½	1.87½	1.87½	1.87½	1.87½	1.87½
ROOFERS	1.50	1.62½	1.50	1.62½	1.25	1.37½	1.50	1.50	1.50
SHEET METAL WORKERS	1.75	1.75	1.75	1.75	1.75	1.75	1.75	1.75	1.75
SPRINKLER FITTERS	1.58	1.58	1.58	1.58	1.58	1.58	1.58	1.58	1.58
STEAMFITTERS	1.87½	1.87½	1.87½	1.87½	1.87½	1.87½	1.87½	1.87½	1.87½
STONESETTERS (MASON)	2.05	2.05	2.05	2.05	2.05	2.05	1.75	2.05	2.00
TILESETTERS	1.80	1.75	1.75	1.75	1.75	1.75	1.37½	1.37½	1.37½

Prepared and compiled by

CENTRAL CALIFORNIA CHAPTER, ASSOCIATED GENERAL CONTRACTORS OF AMERICA

with the assistance and cooperation of secretaries of General Contractors Associations and Builders Exchanges of Northern California.

# CLASSIFIED ADVERTISING

RATE: 10c PER WORD . . . CASH WITH ORDER

MINIMUM \$2.50

**ARCHITECT'S REPORTS**—A valuable advance news service giving building and construction information daily on projects in Northern California. Name, location, architect, proposed cost, etc., on individual slips. Ideal for securing new business leads. Hundreds of items, total monthly cost only \$10. Don't delay, subscribe today. **ARCHITECT & ENGINEER**, Room 618, 68 Post Street, San Francisco, California. Phone DOUGLAS 8311.

**PHOTOGRAPHY**—Keep a pictorial record of your building, or construction project. Pictures are of tremendous value to contractors, builders, engineers, architects. For Industrial-Publicity-Aerial photography, see **FRED MAE**, Room 721-22 Hearst Bldg., San Francisco 3, California.

**METAL WINDOWS** (Steel - Aluminum-Bronze). Large Stock, ALL TYPES, STEEL SASH SALES & SERVICE, Weehawken, N. J.

**ENGRAVING**—Good engravings are essential to a satisfactory job of printing reproduction. For the best, see **Poor Richard Photo Engraving Co.**, 324 Commercial St., San Francisco.

**WANTED ARCHITECTURAL DETAILERS AND DRAFTSMEN** for work on hospital and school buildings. Architect **Robert Stanton**, Crespi Lane, Pebble Beach, California. Phone Carmel 731.

states by the California State Reconstruction and Re-employment Commission in its recent report on "Steel and Steel-Using Industries of California."

This figure is predicated on maximum postwar development, as indicated by plans and prospects of steel-using industries. It exceeds by about 500,000 tons the production capacity of the same states in 1944.

### REINFORCED CONCRETE

Reinforcing bars for concrete have been reduced to five basic designs by the American Iron and Steel Institute, according to a recent report of the National Bureau of Standards. This represents a

reduction from the twenty designs now commercially available.

The purpose of the research is to enable builders and engineers to make more effective use of reinforced concrete.

### PERMIT GRANTED

A CPA permit has been granted for the construction of a 12-room Roman Catholic parochial school building at 18th Ave. and Vincente Sts., San Francisco, to cost \$200,000. The architects are Henry A. Minton & Wilton Smith of San Francisco.

### SEATTLE MANAGER

Byron W. Butler has been appointed manager of the Seattle branch of W. P. Fuller & Co., to succeed George W. Feldman, who retired. He has been with W. P. Fuller & Co. since 1916 and for the past 16 years has been manager of the Salt Lake City branch.

### CONSTRUCTION COMMITTEE MEETS

The construction industries committee of the Los Angeles Chamber of Commerce held a recent luncheon meeting in that city.

Buron Fitts, former district attorney of Los Angeles spoke on: "Future Peace and Security of Our Country."

### AIRPORT ADDITION BIDS TAKEN

Bids are being taken on the \$250,000 addition to the San Francisco Municipal Airport, of which W. P. Day & Associates of San Francisco are the architects. It will be of frame and stucco construction and will contain a restaurant as well as offices for the airlines.

### TO CONSTRUCT WAREHOUSE

The Pacific Rubber Company of Oakland, Calif., has contracted with Barrett & Hilp of San Francisco to build a warehouse and shipping facilities to cost \$165,000. Ellison & King of San Francisco are the structural engineers.

### NEW MANAGER

Clinton T. Hallsted has been appointed manager of the San Francisco sales office of the American Lumber and Treating Company, J. F. Linthicum, president, announced at Chicago recently. Hallsted succeeds Marx Hyatt, who headed the coast office for seven years and resigned to enter business for himself.

### WORLD TRADE CENTER

A \$40,000,000 World Trade Center for San Francisco has been proposed, having as its purpose the development of business with India, Burma, Japan, Korea, the Philippines, Indo-China, Thailand, Malay and Indonesia.

## HOGAN LUMBER CO.

*Wholesale and Retail*

## LUMBER

---

**MILL WORK • SASH & DOORS**

---

*Office, Mill, Yard and Docks*

**SECOND AND ALICE STREETS • OAKLAND, CALIF.**

*Telephone GLEncourt 6861*

## CLINTON CONSTRUCTION CO.

OF CALIFORNIA

### *General Contractors*

**923 FOLSOM STREET • SAN FRANCISCO**

SUtter 3440

## SANTA MARIA INN

**SANTA MARIA, CALIFORNIA**

*FRANK J. McCOY, General Manager*

*FERNAND E. PIMENTEL, Manager*

*American  
or  
European  
Plan  
•  
Old  
English  
Tap  
Room*

*On the  
Coast  
Highway  
between  
San  
Francisco  
and  
Las  
Angeles*



## BOOK REVIEWS

### PAMPHLETS AND CATALOGUES

**COLOR-ENGINEERING BY FULLER.** W. P. Fuller & Co., 301 Mission St., San Francisco, California.

A new 24-page full color booklet containing exact information about the scientific use of color for a wide variety of industrial and commercial problems. Color improves employee relations and promotes safety. Booklets show many color applications and makes specific recommendations. Copies free from manufacturer and dealers.

**"THE SELF-SUPPORTING CITY."** By Gilbert M. Tucker. Robert Schalkenbach Foundation, New York City. \$1.00.

Proposes a more enlightened tax system for urban property, and suggests that taxes on buildings be reduced gradually and taxes on land correspondingly increased until buildings are tax-free. The author believes this will protect property values by encouraging building.

**"PLANNING AND RECONSTRUCTION 1946."** F. J. Osborn, Advisory Editor, Todd Publishing Co. Ltd., London. (Frances Sharp, New York.) 768 pp. \$6.00.

Contains articles on British housing problems and policies, describes progress in various British cities, discusses careers and professions associated with planning. Presents tables and statistics, and "who's who" in planning and reconstruction.

**HIDDEN HAZZARDS, How To Avoid Them When You Remodel or Build Your Home.** North America Companies, 100 Arch St., Philadelphia, Pa.

Printed in two colors this new booklet contains 64-pages and is designed to help reduce injuries and loss of life and property caused by hidden fire and accident hazards which frequently exist because of the use of improper or less desirable building methods or materials. Copies available upon request to publisher.

**"THE FUTURE OF HOUSING."** By Charles Abrams. Harper & Bros., New York, publishers. \$5.

The author proposes a comprehensive housing program and outlines how it can be accomplished. He comments on such factors as housing for low-income families, a sound mortgage system, sound home ownership, a revitalized building industry, slum clearance, adequate rental housing, and housing in a democracy.

## "AMERICAN - MARSH"

CONDENSATION UNIT

Pumping  
Machinery  
for  
Every  
Purpose

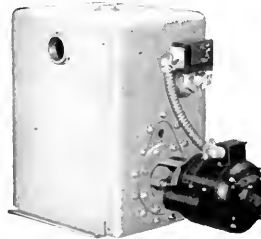

For Service  
Call  
DOuglas  
6794  
or  
MUtual8322

**SIMONDS MACHINERY CO.**  
SAN FRANCISCO      LOS ANGELES  
816 FOLSOM      455 EAST 4TH

## VERMONT MARBLE COMPANY

Producers and Finishers  
of  
Domestic and Imported Marbles

525 MARKET STREET, SAN FRANCISCO  
Phone Sutter 6747

727 W. 7th STREET, LOS ANGELES  
Phone TRinity 3459



The Most Complete Line of  
STEELS and BUILDING MATERIALS  
Made by a Single Producer



See Sweet's Catalog File or write us for  
full information.

**REPUBLIC STEEL CORPORATION**  
GENERAL OFFICES: CLEVELAND, OHIO

DENVER, COLORADO . . . . . CONTINENTAL OIL BUILDING  
LOS ANGELES, CALIFORNIA . . . . . EDISON BUILDING  
SALT LAKE CITY, UTAH . . . . . WALKER BANK BUILDING  
SAN FRANCISCO, CALIFORNIA . . . . . RIALTO BUILDING  
SEATTLE, WASH. . . . . WHITE-HENRY-STUART BUILDING

## PACIFIC MANUFACTURING CO.

HIGH CLASS INTERIOR FINISH  
QUALITY MILLWORK

142 SANSOME ST., SAN FRANCISCO  
GARfield 7755

6820 McKINLEY AVE., LOS ANGELES  
THornwall 4196

**BUILDERS EXCHANGE, OAKLAND**

## IN THE NEWS

### LOS ANGELES PERMITS

Los Angeles maintains its position as the city with the second largest volume of new construction, with New York City in the top spot, according to a recent Dun & Bradstreet report of building permits. Chicago is third and Detroit fourth.

### EXCHANGE CONTRACT AWARDED

The general contract on the \$400,000 telephone exchange to be constructed for Pacific Telephone and Telegraph at San Jose, Calif., has been awarded to Swinterton and Walberg of San Francisco. Harry A. Thomsen, Jr., also of San Francisco, is the architect.

### THEATER STARTED

Work has been started on the new \$200,000 Ritz Theater on Geary Street, east of Arguello Blvd., San Francisco. The architect is A. R. Walker of Los Angeles and the general contractor Cahill Brothers, San Francisco. The theater will have a seating capacity of 1600 and is to be reinforced concrete and structural steel construction.

### U. C. CHEMIST HONORED

Professor Glen T. Seaborg, noted University of California nuclear chemist, has been appointed counselor-at-large by the American Chemical Society.

One of the chief chemists on the atomic bomb project, Professor

Seaborg is a co-discoverer of plutonium, americium and curium. He was recently appointed a member of the advisory board of the Atomic Energy Commission by President Truman.

### NEW CONNECTORS

A series of two-screw connectors, capable of gripping a cable or cord securely and providing uniform pressure on the cable, is now

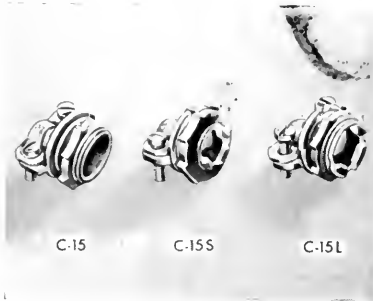

manufactured by the **Gedney Electric Company** of New York City. It can be used to terminate practically any kind of cable or cord in a standard 1/2 inch K. O., and is easy to install.

Available in three models as above illustrated.

### TO BUILD HOSPITAL

Bids have been taken on the \$250,000 40-bed hospital at Tracy, Calif., by the owner, the Tracy Community Memorial Hospital Association. The architects are Fred L. Swartz & William G. Hyberg, both of Fresno, Calif.

### DESIGNS CONVENT

Vincent Buckley, architect, of San Francisco, has been selected to design the Roman Catholic convent building at Hayward, Calif.

### NEWSPAPER PLANT

A new \$2,500,000 plant for the Seattle Post-Intelligencer will be constructed by the Howard S. Wright & Co., of Seattle. The building will be a two-story newspaper plant and will cover a square block.

### MODESTO HIGH SCHOOL ADDITIONS

The Board of Education of Modesto, Calif., is taking bids on the general contract for the building of additions to the Modesto High School, approximate cost, \$300,000. Harry J. Devine, Sacramento, is the architect.

### BRISK BUSINESS

Robust interest in the Second Annual Construction Industries Exposition and Home Show, to be held at the Pan-Pacific Auditorium in Los Angeles, June 12 to 22, is indicated by the fact that 75% of the display space has already been reserved, President Milton J. Brock, has announced.

### VANT RULE

The **Vant Rule**, a new drafting scale made of transparent plastic with eight scales on one side, is

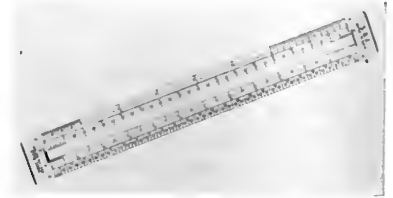

manufactured by the Stewart-Jackson Instrument Company of Los Angeles. Calibrations and numerals are in red to facilitate reading against black and white drawings or blue prints. Overall length 13 1/2" with scales reading to 12".

### ARCHITECT MOVES

John Davis Young, architect, has moved from Menlo Park to 2002 California St., San Francisco.

### NEW ENGINEER OFFICE

Holmes and Narver, engineers, announce a new address at 824 So. Figueroa St., Los Angeles 14, Calif.

ARCHITECT AND ENGINEER

**IT'S TOUGH — SURE, IT'S ALSO WATERPROOF AND WINDPROOF**

**Specify**

**SISALKRAFT REINFORCED BUILDING PAPER**

**FOR CURING AND PROTECTING  
CONCRETE SHEATHING  
AND COVERING MATERIAL**

**GUNN CARLE & CO**  
**20 POTRERO AVENUE • SAN FRANCISCO, CALIF.**

## ELMER F. STEIGELMAN

CIVIL ENGINEER

**Structural Design,  
Surveying and  
Subdivisions**

577 FOURTEENTH STREET  
OAKLAND, CALIFORNIA

TWinoaks: 4191

## IN THE NEWS

### ATOMIC COURSE

A new engineering course, "Theory and Design of Chain-Reacting Piles," is being offered by the University of California Extension at Los Angeles campus.

The national program of atomic development and research requires a huge number of technically-trained engineers familiar with the elementary physics and design of piles.

### METAL CASEMENTS

Aluminum-frame storm windows for metal casements provide complete coverage of the casement and allow full operation of ventilators. A controlled ventilator may be desired, as shown.

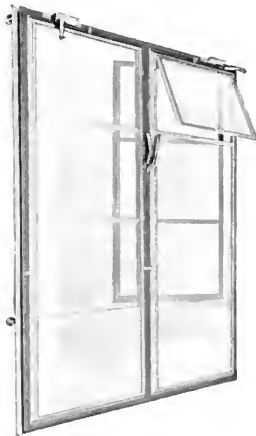

Easily installed from the inside by use of storm sash fasteners, these storm windows are light and provide insulation between the casement unit and the sash panels. Made with double-strength glass and extruded aluminum by Ceco Steel Products Corporation of Chicago, Ill.

### PLACE TO TINKER

"Does your home have a place for living?" asks the General Electric Company in a recent bulletin.

The point is made that most home design takes care of all purely functional needs, but makes no allowance for hobbies and tinkering.

### STEEL LOST

The steel industry lost 16,000,000 tons of steel as a result of strikes in 1946, according to U. S. Steel Chairman Irving S. Olds.

Phone GARfield 1164

## Thomas B. Hunter

Consulting Engineer

DESIGNER OF HEATING  
AIR CONDITIONING  
VENTILATING AND WIRING  
SYSTEMS, MECHANICAL  
AND ELECTRICAL EQUIP-  
MENT OF BUILDINGS

41 SUTTER STREET  
ROOM 710

San Francisco

California

## METAL WINDOWS

Steel—Aluminum—Bronze

Large Stock—ALL TYPES

Steel Sash Sales & Service

Weehawken, N. J.

## MULLEN MFG. COMPANY

BANK, STORE AND OFFICE  
FIXTURES—CABINET WORK  
OF GUARANTEED QUALITY  
CHURCH SEATING

Office and Factory:  
60-80 RAUSCH ST., Bet. 7th and 8th Sts.  
San Francisco  
Telephone UNderhill 5815

## THE TORMEY COMPANY

GENERAL PAINTERS  
AND DECORATORS

Phone UNderhill 1913

563 FULTON STREET  
San Francisco

## Scott Company

HEATING - - PLUMBING - - TILE



243 MINNA STREET  
SAN FRANCISCO  
Phone EXbrook 6741

## DINWIDDIE CONSTRUCTION COMPANY

BUILDERS

CROCKER BUILDING  
SAN FRANCISCO



## HERRICK IRON WORKS

STRUCTURAL STEEL  
REINFORCING STEEL

18TH AND CAMPBELL STS.  
OAKLAND, CALIF.  
Phone GLencourt 1767

## A. F. MATTOCK CO.

*Builders*

★

212 CLARA STREET  
SAN FRANCISCO

## INDEPENDENT IRON WORKS

Steel Buildings  
Service Stations  
Steel Storage Tanks  
Fabricated Plate Work  
Steel & Sheet Metal Products  
Fabricated Structural Steel  
Steel Distributors

Eighth & Pine Sts. Oakland, 7

## George F. Brayer

ELECTRICAL  
CONTRACTOR

166 Seventh Street  
San Francisco

Phone: Market 1761

## PITTSBURGH TESTING LABORATORY

Successors to  
SMITH, EMERY & COMPANY

*Testing and Inspecting  
Engineers and Chemists*

Structural Materials, Structures  
Equipment, Pipe, Soils.

651 Howard St., San Francisco 5  
EXbrook 1747

## Index to Advertisers

ALADDIN Heating Corp.	48
AMERICAN Roof Truss Co.	34
ARCHITECTS Reports	40
BASALT Rock Company	Back Cover
BAXTER & Company, J. H.	36
BRAYER, Geo. F.	48
CLASSIFIED Advertising	43
CLINTON Construction Company	44
DINWIDDIE Construction Company	47
FORDERER Cornice Works	39
FULLER, W. P. Co.	*
GUNN, Carle & Company	46
HANKS, Inc., Abbot A.	48
HAWS Drinking Faucet Company	1
HERRICK Iron Works	47
HOGAN Lumber Company	44
HUNT, Robert W., Company	48
HUNTER, Thos. B.	47
INDEPENDENT Iron Works	48
JUDSON, Pacific-Murphy Corp.	39
KRAFTILE Company	32
MATTOCK, A. F.	48
MICHAEL & Pfeffer Iron Works	Inside Back Cover
MULLEN Mfg. Co.	47
MUELLER Brass Co.	*
NORTHERN California Electrical Bureau	35
PACIFIC Coast Gas Association	Inside Front Cover
PACIFIC Manufacturing Company	45
PACIFIC Portland Cement Company	*
PACIFIC Telephone & Telegraph Co.	33
PITTSBURGH Testing Laboratory	48
PORTLAND Cement Association	*
REMILLARD-Dandini Co.	48
REPUBLIC Steel Corporation	45
SANTA Maria Inn	44
SCOTT Co.	47
SIMONDS Machinery Company	45
SISALKRAFT Company	39
SMOOT-Holman Co.	37
STANLEY Works, The	*
STEIGELMAN, Elmer F.	47
STEEL Sash Sales & Service	47
TAYLOR Co., Halsey W.	30
TORMEY Company, The	47
U. S. BONDS	2
VERMONT Marble Company	45
WESTERN Asbestos Company	*
WOOD, E. K., Lumber Company	36

\* Indicates Alternate Months

## Robert W. Hunt Company

ENGINEERS

Inspection - Tests - Consultation

Schools and Other Structures  
Are Built as Designed

*When Construction Materials are  
Inspected at point of Manufacture  
and during Erection by*

**ROBERT W. HUNT COMPANY**

*Cement, Concrete, Chemical, Metallurgical,  
X-Ray and Physical Laboratories*

Chicago - New York - Pittsburgh  
Los Angeles - All Large Cities  
San Francisco, 251 Kearny Street

## REMILLARD-DANDINI Co.

Brick and  
Masonry Products

★

400 MONTGOMERY STREET  
SAN FRANCISCO, CALIF.

## ALADDIN Heating Corp.

Specializing in  
QUALITY HEATING  
EQUIPMENT

2222 San Pablo Avenue  
OAKLAND  
TWinoaks 1022

## ABBOT A. HANKS, INC. Engineers & Chemists

INSPECTING — TESTING — CONSULTING  
CONCRETE • STEEL • MATERIALS  
CHEMICAL AND TESTING  
LABORATORIES

• RESEARCH AND INVESTIGATION •

TESTS OF STRUCTURAL MATERIALS  
DESIGN OF CONCRETE MIXES  
SHOP AND ERECTION INSPECTION OF  
STRUCTURES AND EQUIPMENT  
INVESTIGATION OF STRUCTURES  
AND MATERIALS  
TESTS AND INVESTIGATION OF  
FOUNDATION SOILS  
FIRE RESISTANCE AND INSULATION  
TESTS

624 Sacramento Street, San Francisco

# ARCHITECT AND ENGINEER

CHANNEL HEIGHTS HOUSING PROJECT, San Pedro, California



MARCH

1947

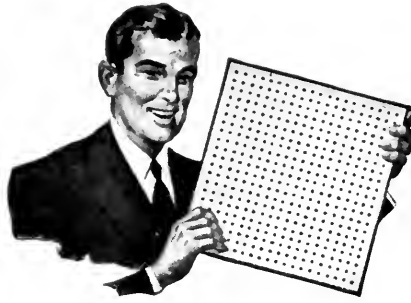

# OVER 1000 YEARS of Combined Acoustical Experience

**... At Your Service Through Western Asbestos Co.  
Your Acousti-Celotex Distributor**

**M**ORE THAN 1000 years of combined experience, gained in over 100,000 installations—this is the great reservoir of practical knowledge available to you *only* through the Acousti-Celotex\* Distributor Organization of which Western Asbestos Co. is your representative.

This knowledge has been gained in good company. For the nationwide Acousti-Celotex group has collaborated with hundreds of architects in effecting solutions to noise quieting problems.

Every day the men of this organization are helping to solve such problems as:

- How to diagnose acoustical and noise quieting difficulties . . .
- How to reduce distracting noise to a gentle hush . . .
- How to design architecturally for optimum acoustics . . .
- How to be sure of mechanical perfection in the proper acoustical material and its application . . .
- How to make sure of the acoustical installation's perfect appearance and continued satisfactory performance through the years.

*Every man* in this nationwide organization is hand picked. He is thoroughly trained in sound-conditioning practice. As a result, when you turn a job over to him, you know it will be trouble-free.

No matter how much or how little assistance you may need, Western Asbestos Co. is willing and able to help you without obligation. This extra service in no way affects their ability to compete on the smallest or the largest job you may have. That service is the unwritten *plus value* that goes with every specification for Acousti-Celotex.

A phone call or a note will bring a trained sound-conditioning expert to you from Western Asbestos Co.'s staff.

## **WESTERN ASBESTOS CO.**

DISTRIBUTORS • ENGINEERS • CONTRACTORS

SAN FRANCISCO: 675 TOWNSEND STREET, HEMLOCK 4884

OAKLAND: LATHAM SQUARE BUILDING, TEMPLEBAR 7474

SACRAMENTO: 1224 EYE STREET, SACRAMENTO 2-8993

FRESNO: 1837 MERCED STREET, FRESNO 3-3277



*Sound Conditioning with*  
**ACOUSTI-CELOTEX**

\* *Perforated Fibre Tile* REG. U.S. PAT. OFF.  
SINCE 1923



# • ARCHITECT

Vol. 168 No. 3

ARCHITECTS' REPORTS—Published Daily  
Telephone DOuglas 8311

# AND ENGINEER

E. H. WILDER  
Editor

MARK DANIELS, A.I.A.  
Associate Editor

JOHN S. BOLLES, A.I.A.  
Book Reviews

MICHAEL GOODMAN  
Post-War Planning

L. H. NISHKIAN  
Consulting Editor

E. N. KIERULFF\*  
Ass't Editor  
\*In the Service



Contents for

## MARCH

COVER PICTURE: Channel Heights Housing Project, San Pedro, California.  
Richard J. Neutra, Architect. (See Page 14)

### ARTICLES AND MISCELLANEOUS TEXT

EDITORIAL NOTES . . . . .	4
NEWS AND COMMENT ON ART . . . . .	6
HOW MANY COLORS CAN WE DISTINGUISH? . . . . . By DR. W. SCHWEISHEIMER	10
DISTINGUISHED HONOR AWARDS, Southern California Chapter, A. I. A. . . . . Channel Heights Housing Project, San Pedro Richard J. Neutra, Architect Kelton Apartments, Westwood Richard J. Neutra, Architect House for John B. Nesbitt, Brentwood Richard J. Neutra, Architect Baldwin Hills Village, Los Angeles Reginald D. Johnson, Architect Wilson, Merrill, Alexander, Associated and Clarence S. Stein, Consultant	14
SOUND MOTION PICTURES, For Schools and Auditoriums . . . . . By JOHN A. HOWLAND	27
WESTINGHOUSE, San Francisco Office Building . . . . .	30
A. I. A. ACTIVITIES . . . . .	31
WITH THE ENGINEERS . . . . .	32
HEADLINE NEWS & VIEWS . . . . . By E. H. W.	36
IN THE NEWS . . . . .	37, 43, 44, 46, 47
ESTIMATOR'S GUIDE, Building and Construction Materials . . . . .	41
BUILDING TRADES WAGE SCALES, Northern and Central California . . . . .	43
CLASSIFIED ADVERTISING . . . . .	43
BOOK REVIEWS, Pamphlets and Catalogues . . . . .	45

ARCHITECT AND ENGINEER (Established 1905) is published on the 15th of the month by The Architect and Engineer, Inc., 68 Post St., San Francisco 4; Telephone EXbrook 7182. President, K. P. Kierulff; Vice-President and Manager, L. B. Penhorwood; Treasurer, E. N. Kierulff.

Los Angeles Office: Wentworth F. Green, 6605 Hollywood Blvd., Los Angeles 28. Telephone HEMpstead 3171.

Entered as second class matter, November 2, 1905, at the Post Office in San Francisco, California, under the Act of March 3, 1879. Subscriptions United States and Pan America, \$3.00 a year; \$5.00 two years; foreign countries \$5.00 a year; single copy 50c. ARCHITECTS' REPORTS are published daily from this office, Vernon S. Yallop, Manager.



# • EDITORIAL NOTES •

## THE ARCHITECT AS AN INTERPRETER

"To interpret contemporary life adequately an architect should be doubly armed. He should know the Past as he knows the Present. Neither can be ignored if he is to fulfill this all important responsibility.

"Whatever delight some may find in the study of History for its own sake, we should bear in mind that in an architect's education it is essentially a means to an end rather than an end in itself. Yet throughout the ages each country has a story to tell whether it be China, Egypt, Greece, Rome, or Byzantium, each reveals through its architecture how it solves its own problem of living—what it values, what indeed it cannot live without . . . Indeed no School of Architecture should be without some wise interpreter of the past who brings the monuments of history to life and demonstrates from them the ways and means to the solution of our own problems—in brief, someone who senses those underlying principles of design which apply as inescapably today as they did yesterday and as they will tomorrow to all architecture worthy of the name.

"A knowledge of the Past may thus help us the more clearly to understand the Present and to guide us to the Future. But remember that the Past is ever close upon the heels of the Present, that we move momentarily from one to the other and must therefore be informed of the very latest improvements in building methods, mechanical equipment, and new materials . . .

"The architecture that we hope will survive, as evidence to other ages of what our own civilization has been, should not be an ephemeral stopgap to meet a merely transient need. Architecture in its fullest sense expresses needs of so lasting and so fundamental a nature that its value must be apparent in the future as on the day it was conceived. . . ." Excerpts from an article in "ARCHITECTURE, A Profession and A Career," by William Emerson F.A.I.A., former Dean, School of Architecture and Planning, and professor Emeritus, Massachusetts Institute of Technology, and published by the American Institute of Architects, Washington, D. C.

## FACTS SPEAK FOR THEMSELVES

Some exception has been taken to the Editorial comment appearing in our last issue relative to the State of California engaging in the practice of

architecture to the exclusion of private enterprise.

The fact remains that if the architectural effort emanating from the California Division of Architecture were allocated to private practice, there are of large number of architects who would benefit and the distribution of funds into local channels of commerce would result in an economic advantage—even to the State of California.

The industrial and commercial expansion throughout California, which is the basis of the proposed highways construction program to extend over a period of some ten or twelve years, will only be possible if free enterprise is given an opportunity to function without oppressive restrictions, city, county, or state.

The building of millions of dollars worth of state highways, and possibly an even greater expenditure in other public works, on the same engineering and contracting conditions as currently exist in the Division of Architects, will result in a tremendous loss to the taxpayers, who after all—aside from being Architects, Engineers, and Contractors—pay the bill of government operation.

\* \* \*

## JUSTIFIED RECOGNITION

Considerable stimulation will be given MODULAR COORDINATION by a recent research grant from the U. S. Department of Commerce to the Modular Service Association. According to the Producers' Council, a group which has been particularly active in developing Modular Coordination, the grant includes a provision that certain funds are to be used for the training of more "experts."

And along with this announcement comes word that James R. Edmunds, Jr., President of the American Institute of Architects has secured adoption of modular design and products for the entire Veterans' Hospital Program.

Recognition of the principles of Modular Coordination by the Federal government in these two important instances will accrue to the eventual benefit of the entire building and construction industry.

\* \* \*

## MELTING RESERVES

A rapid dissipation of the national savings reserve is taking place, a recent survey indicated. A tremendous volume of war savings bonds is being cashed in. Strikes are absorbing savings, and capital reserves which would otherwise be available for home ownership are melting away.

# DEPENDABLE



A  
"PACIFIC  
PRODUCT"

*Produced by*  
**PACIFIC PORTLAND  
CEMENT COMPANY**  
San Francisco • Los Angeles  
Portland

*Sold by*  
**YOUR BUILDING  
MATERIALS DEALER**

## UNIFORM - TIME TESTED



"I REMEMBER THAT DAY"

Watercolor by EDNA STODDART

San Francisco Art Association Purchase Prize, 11th Annual Watercolor Exhibition

## 11th Annual Watercolor Exhibition San Francisco Museum of Art

Three of the top prizes in the 11th Annual Watercolor Exhibition held recently went to Bay Area artists, whose contributions were selected from the 106 entries, which were in turn selected from some 500 submissions to the jury.

Edna Stoddart of Oakland, Calif., winner of the Purchase Prize of \$75, studied at Mills and the California School of Fine Arts, later privately under Nepote, Wessels, Kingman and Gaw. She has been painting and exhibiting for ten years, but it has never been more than a hobby. "I Remember That Day" was her entry.

The \$50 Artist's Fund prize was won by Evelyn Bailey Breezee, of Berkeley, California, with her gouache, "Market." Miss Breezee was born in Seattle, but has painted and exhibited in the Bay region for many years. She teaches at El Cerrito High School and the California School of Arts and Crafts.

Another Berkeley artist to capture an award was Rex Ashlock, winner of the \$50 Mrs. John I. Walter prize with his contribution, "Rocks," in watercolor. Ashlock has a studio in San Francisco and is an instructor of drawing at the California School of Arts and Crafts. He studied at the University of Washington and the California School of Fine Arts after coming from Spokane, Washington.

Miyoko Ito, winner of the Paul Bissinger prize of \$50 with his watercolor, "The Dusty Road," is a Chicagoan whose paintings have been seen here before in the Art Association annuals.

The winner of the \$25 W. P. Fuller Brawner Prize for her gouache, "Little Girl," Mildren Henard is now a graduate student at the University of California, but hails from Austin, Texas. This is the first showing of her work in San Francisco. Before coming here she exhibited frequently in Texas, particularly at the Texas General, annual Austin

showing. She is an elementary school teacher and intends to return to that work after completing her present studies.

Honorable Mentions were received by Esther Fuller, of Oakland, Calif., for her "Woman," a pastel; Ralph S. Ducasse, Piedmont, Calif., for his "From the Hill," tempera on paper; John E. French, Mill Valley, Calif., for his watercolor, "Flowers"; and Tom Valiant, Fresno, Calif., for his gouache, also entitled "Flowers."

The jury of selection consisted of Alexander Nepote, chairman, Edgar Taylor and Glenn Wessels of Berkeley, Emmy Lou Packard and Hassel Smith. The jury of awards was made up of Edgar Taylor, Glenn Wessels and Alexander Nepote.

\* \* \*

**EXHIBITIONS:** The museum's 11th Annual of Watercolors sponsored by the San Francisco Art Association will continue through April 3.

Oil paintings by Walt Kuhn will be shown through April 6, and Expressionism in Prints from the Museum of Modern Art will be on exhibition through March 25.

Other March showings include: Integrated Building, Museum of Modern Art, 15 colored panels of photography and drawings; Alexander Calder, sculpture and painting; and I. Rice Periera, paintings.

\* \* \*

**MUSEUM ACTIVITIES:** A Folk Dance Demonstration sponsored by the Folk Dance Federation of California will be held Fridays at 8:30 P.M. through March 28.

\* \* \*

**WOMEN'S BOARD ACTIVITIES:** Alfred Frankenstein, art critic of the San Francisco Chronicle, will deliver a lecture on Alexander Calder.

A panel discussion with Joseph Esherick, Architect, Prentice French, landscape architect, and Mrs. Ferdinand Smith, decorator, participating, will take place on March 18.

**FILMS:** The "Know Your World Series" of motion pictures with performances on Saturday and Sunday at 2:30 P. M. is scheduled as follows: March 15 and 16, "American Indian;" March 22 and 23, "Arctic and North British Columbia;" March 29 and 30, "India."

**FAMOUS FILM SERIES**—Tuesdays at 2:30 P.M.: March 18, "Catherine The Great;" March 25, "Le Courier De Lyon."

### PORTLAND ART MUSEUM

Enrollment at the Museum Art School now stands at 511, an increase over last term of 15%. Many out-of-state students are enrolled, and have

come from Maine, Massachusetts, Florida, Virginia and New York, as well as from relatively nearby Idaho and Washington.

William H. Givler, dean of the school, explains the flood of students by pointing out that this is the only school in the Pacific Northwest region that devotes itself exclusively to art training.

### CALIFORNIA PALACE OF THE LEGION OF HONOR

**EXHIBITIONS:** A loan exhibition of 19th Century French Drawings opened on March 8. Other exhibitions include Paintings by Margaret Tomkins; Prints by Roderick Mead; the Alma de Bretteville Spreckels Collection of Sculpture by Auguste Rodin; the Mildred Anna Williams Collection of Paintings, Sculpture, Tapestries and Furniture; and the Collis Potter Huntington Memorial Collection of 18th Century French Paintings, Sculpture, Tapestries, Furniture and Porcelain.

\* \* \*

**CHILDREN'S ART CLASSES:** Classes for children from ages 4-12 continue each Saturday morning at 10:30 under direction of Katherine Parker, Lilly Weil Jaffe and Rex Mason. Children may enroll at any time, no admission.

\* \* \*

**ADULT PAINTING CLASS:** The painting class for adults under direction of Rex Mason continues on Saturday afternoons at 2:30. Enrollment any time, no admission fee.

\* \* \*

**SPECIAL LECTURES:** A series of special lectures on the 19th Century French Drawing Exhibition will be given by Thomas C. Howe, Jr., on Wednesday at 10:30 A.M., with lectures set for March 12, 19 and 26. Admission free.

\* \* \*

Uda Waldrop organ recital every Saturday and Sunday at 3 p.m. and an organ concert broadcast over station KSFO at 3:30 p.m.

### SAN FRANCISCO ART ASSOCIATION

**NEW COUNCIL MEMBERS:** The following new members were elected to serve on the Artists' Council for the ensuing three years at a recent meeting of the association: Elmer Bischoff, Mary Erckenbrack, Caroline Martin, Otis Oldfield, Mary Lou Packard, and Clay Spohn.

Robert McChesney was appointed to replace James McCray, whose term expires in December, 1947. Completing the roster of Council members are Paul O. Forste, chairman, Ruth Armer, Brents Carlton, Jose Moya del Pino, Donald Forbes, Hal Goldman, Dorothy Grover, Leah Rinne Hamilton,

(See Page 9)

From the permanent collection on exhibition at the  
deYoung Museum

EDWARD H. HARRIMAN (1848-1909)

AUGUSTE RODIN (1840-1917)

French

Rodin, the most modern of all modern sculptors, drew upon the tradition of all great epochs. Some of his works have nothing to fear from comparison with the masterpieces of Greek art or with the sculptures by Michelangelo.

The bust of Edward H. Harriman, the American railroad magnate, is included among the impressive portraits of our century, including Bernard Shaw, Victor Hugo, Berthelot, Clemenceau, and Gustav Mahler.

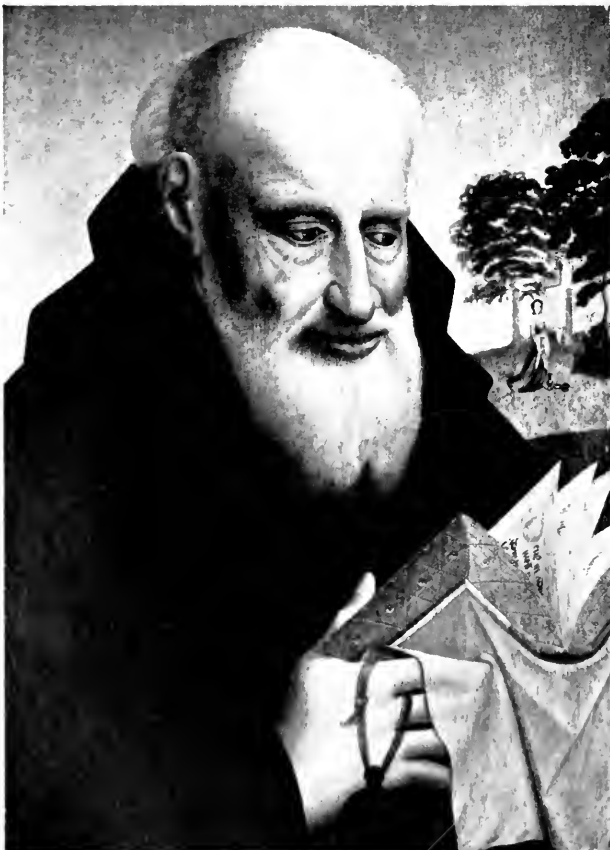
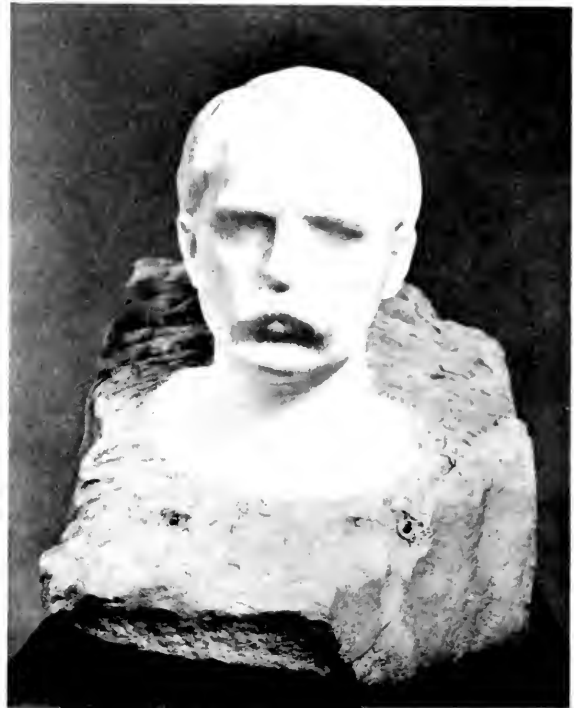

From the permanent collection on exhibition at the  
deYoung Museum

ST. ANTHONY THE HERMIT

French—xv century

Devotional figures of St. Anthony occur frequently and are easily recognized. He has several distinctive attributes, each significant of some trait in his life or character, or of the sanctity and spiritual privileges popularly ascribed to him.

In the schools of art particularly influenced by Greek traditions, the figure of Anthony, besides the monkish garb, bears the letter T, the first letter of the Greek word Theos, God, on the shoulder.

St. Anthony is usually depicted with a book in his hand, as he is the author of seven theological epistles still extant, and a book was given to all the early fathers who left writings behind them.

The bell, which he carries in his hand, has reference to his power to exorcise evil spirits. It is a legend that the devil cannot endure the sound of a consecrated bell.

For these are they which follow the Lamb whithersoever he goeth. These were redeemed from among men, and in their mouth was found no guile, for they are without fault before the throne of God.

Revelation xiv.1.

Often quoted in reference to St. Anthony, and the elect, who are redeemed from the earth bearing the Letter T, God the Father.

Adaline Kent, Douglas MacAgy, David Park, Rose Pauson, Worth Ryder, Jacques Schnier, Eldridge T. Spencer and Ruth Cravath Wakefield.

\* \* \*

**POETRY PRIZE OFFERED:** Trustees of the estate of the late Senator James D. Phelan have announced an award of \$1250 for 1947, open only to writers of poetry. Applications for the award must be native born Californians between the ages of 20 and 40, and may obtain their applications from the James D. Phelan Award Office, 820 Phelan Building, San Francisco.

\* \* \*

**ELECT NEW OFFICERS:** Spring term elections of the California School of Fine Arts for officers to head the Student Association resulted in Jack Foote being elected president; Hal Painter, vice-president; Lee Plato, secretary; and Beverly Kirby, treasurer.

A full program including several student exhibitions as well as a number of social events is being planned.

\* \* \*

The American Institute of Decorators has announced the award of a special Citation of Merit to Dorothy Liebes, noted San Francisco textile designer and a member of the association's board of directors, for her entry of a block pattern of wool, rayon, and flax weave. It was chosen from among works submitted by the foremost textile firms of the world, and was praised for "its fine texture, simplicity and adaptability to all types of exteriors" by a jury composed of leaders in the fields of industrial design, decorative arts and architecture.

\* \* \*

**INVITED TO EXHIBIT IN THE EAST:** The Dorothy Liebes Studio has been invited to exhibit in the closing show of the Athenaeum in Providence, Rhode Island, at the Rhode Island School of Design and at the Boston Institute of Modern Art.

**M. H. DE YOUNG MUSEUM**

**EXHIBITIONS:** Several notable exhibitions are planned for March including: Transparency and Reflection by Clare Falkenstein; Water Colors and Oils by John Thompson; Water Colors and Drawings by Keith Crown; Prints by Reinhard Schmidhagen; Water Colors and Oils by William E. Wiedemann; Chinese Porcelain, lent by the Metropolitan Museum of Art.

\* \* \*

**LECTURES:** Winfield Scott Wellington, Director of the Art Gallery at the University of California, Berkeley, will lecture on "Alaskan Art" during March.

**CLASSES:** The "Painting for Pleasure" course for adults is being conducted by Charles Lindstrom. Beginners' class is held on Saturday morning from 10:30 to noon, Tuesday afternoon from 2:00 to 4:00, or Saturday afternoon from 2:00 to 4:00.

The advanced course for those who have completed the beginner's course meet on Wednesday afternoons from 2:00 to 4:00.

\* \* \*

**FOR CHILDREN:** Miriam Lindstrom conducts the children's class for intermediates on Saturday afternoons from 2:00 to 4:00. This class is for young people from 10 to 15 years who are seriously interested in art.

The class for children from 5 to 10 years meets on Saturday mornings from 10:30 to 11:30. It includes drawing, painting and clay modeling and is free to all children.

**WEST COAST ADVERTISING ART WINNERS**

The winners in the Second Annual Exhibition of West Coast Advertising Art, now being displayed at Baker Bros., Los Angeles, were: Pauline Annon, who received the George W. Kleiser award for her 24-sheet outdoor board prepared for Haggerty's; Joe DeMers, winner of the Art Directors Club medal for the best color illustration; David Lockhard and Dillon Lauritzen gained the Art Directors' medal for the best black and white drawing, and Sylvia Hoffman for the best black and white photograph.

**CALIFORNIA SCHOOL OF FINE ARTS**

**EXHIBITION:** Recent works by the winners of the Rosenberg Fellowship since 1940 will be exhibited during March. It will include the works of Ray Bertrand, Hassel Smith, Mary Navratil, Theodore Polos, William Hesthal, Lloyd Wulf, William Clarke, Sargent Johnson and Roland Bladen. Both paintings and sculpture will be displayed.

\* \* \*

**ANNOUNCEMENT** is made by the San Francisco Art Association of the Abraham Rosenberg Fellowship for 1947. This award of \$1500, involving advanced study in art, is open to painters and sculptors who have attended the California School of Fine Arts for at least two semesters. It will be granted for one year to an applicant, or applicants, without restriction as to sex, race, color or creed.

The fellowship is intended primarily for study abroad, although consideration will be given applicants who desire to pursue special research in this country. Applications must be received by the Board of Directors of the Art Association by April 1st of this year; work must be delivered by April 15th. Further information and application forms

may be secured from Nealie Sullivan, Executive Secretary of the Association, 800 Chestnut Street, San Francisco (Phone ORdway 2640).

The Fellowship was bequeathed by the late Abraham Rosenberg in the form of an endowment fund, revenue from which is being used to encourage gifted students of art who need extended study in their particular field. Its purpose is to assist artists of exceptional qualifications toward contributing to the culture of America through painting or sculpture.

---

### **CITY OF PARIS**

An exhibition of oils, watercolors and pastels by Rubin, Helen Salz and Alexander Nepote will be featured at the Rotunda Gallery, 4th floor through March 29th.

\* \* \*

Screen prints (serigraphs) by eastern and western artists will be on display at the Art in Action Shop, 5th floor through March. There will be a demonstration of hand weaving daily from 10 A. M. to 3 P. M., and pottery thrown off the wheel from 11:30 to 4:30 P. M.

---

### **LOS ANGELES WAR MEMORIAL PROGRESSES**

The Los Angeles War Memorial and Opera House, a multi-million dollar project developed by the Greater Los Angeles Plans, Inc., was brought into sharper focus recently when the building sites and financing support were revealed.

More than 200 Los Angeles business and civic leaders met recently at the Biltmore Hotel and learned what has been a well-kept secret for more than a year—the 23-acre downtown auditorium site and the 11-acre Wilshire district site for the opera house.

Officers of the Greater Los Angeles Plans explained that secrecy was necessary to prevent real estate speculation that would greatly increase the cost of the project. Much of the property needed has now been purchased outright or is covered by option.

The auditorium, which is to have a seating capacity of 30,000 persons, is expected to make Los Angeles a principal convention city, in addition to providing an arena large enough for the presentation of indoor spectacles and major athletic events.

The seating capacity of the opera house will be determined by subsequent studies and from the recommendations of engineers, especially acoustical engineers.

### **TEN-STORY LOS ANGELES OFFICE BUILDING**

A ten-story office building of reinforced concrete and steel frame will be constructed at the north-east corner of Wilshire Blvd. and Burlington Ave., Los Angeles, for the Guarantee Insurance Company of Los Angeles, total cost estimated at \$1,000,000. Claude Beelman is the architect and Herman Spackler the associate architect.

The building will have a 75-foot frontage on Wilshire Blvd. and a depth of 50 feet. The rear portion of the property will provide for a semi-subterranean garage with a concrete slab roof parking area. Plans provide for two elevators.

McNeil Construction Company of Los Angeles is the general contractor.

---

### **LOW BID POLICY ON HIGHWAY WORK**

The existence of adequate competition by responsible contractors is the important factor in establishing the propriety of contractor's bid prices on highway projects, the contractors themselves decided at their recent convention in Philadelphia.

Where there is a question of the propriety of bid prices, it is desirable for state highway departments to confer with representatives of contractors' associations or the low bidder before the bids are rejected, so that all factors affecting the bid can be discussed, the contractors believe.

Opinion appeared to be unanimous at the convention that highway departments should specify the results desired and leave to the contractor the methods he should adopt.

It was pointed out that when the department specifies a particular method, it assumes responsibility for results under that method.

---

### **NEW BUILDINGS AT U. C. L. A.**

Two new engineering buildings will be ready for spring occupancy on the Los Angeles campus of the University of California, Dean L. M. K. Boelter, College of Engineering, recently announced.

Both buildings are temporary and will be known as Temporary Engineering Buildings Nos. 1 and 2, the former a \$90,000 machinery laboratory building, and the latter a \$46,000 tool room.

Mounted on its permanent base at the rear of the tool room is the high altitude testing chamber, purchased by the University recently from the War Assets Corporation. Capable of reproducing altitudes up to 60,000 feet, this piece of equipment will be used to test men and materials under varying conditions of pressure and temperature.



# How Many Colors Can We Distinguish?

**Painters and Interior Decorators Know more  
Colors by Shade than by Name**

**By DR. W. SCHWEISHEIMER**

The great Italian painter Titian (1477-1576) once said that a painter must have perfect command of but three colors: white, red and black.

This does not mean that painters are limited as to choice of colors. The human eye can distinguish differences among two million colors and shades,—according to a report of the Inter-Society Color Council which consists of delegates from several scientific and industrial organizations interested in standardizing colors and shades. So far 7,044 colors and their shades have been tabulated, it was reported earlier by M. Rea Paul, co-author of the Maerz and Paul Dictionary of Colors. Standard English dictionaries, however list only about 3,400 words for these seven-thousand-odd shades.

Hardly any part of the human language is as helpless and undeveloped as the naming of colors and their shades. You may walk into a paint store or textile store, ask for a piece of goods and try to describe the color you want. "It should be red, dark red, saturated red, like red carnation, you know, not a green shade in it." But not until you have seen twenty or thirty samples you will find what you are looking for.

## **Original Names for Colors**

Originators of colors have a hard task finding the proper names. The names of natural colored objects have long since been practically exhausted: names of flowers, fruits, vegetables, metals, minerals, gems, aspects of nature such as the sky, sea, etc. Several efforts were made by color experts to arrange tables or dictionaries of colors. There are

scales of color hues which provide each one with a certain number or several numbers. Colors are designated by numbers and subdivisions of numbers. Much admired is the system of color organization originally developed by Wilhelm Ostwald, Leipzig physical chemist and receiver of the Nobel prize. Since 1915 Color Cards have been issued by the Textile Color Card Association of the United States—two season cards a year. This introduction has proved a remarkable progress for industry.

Industry has in the past originated a myriad of names of colors,—they have disappeared being too inexact. In the sixteenth century, we are told in Challamel's History of Fashion in France, Frenchmen wore colors,—and great was their number, —from Rat-color to that called Widows-Joy, or Envenomed Monkey, or Chimney-Sweep. Maerz-Paul's Color Dictionary mentions among others the following color descriptions connected with fashion in eighteenth-century France: Rash Tears, Paris Mud; Brand from the Opera; Burnt Opera House; Stifled Sight; Elliott's Red-Hot Bullets; The Smoke of the Camp of St. Roche. The modern systems and color cards are reliable and scientific though less poetic.

However, when certain colors and shades **had** to be named, there was no real lack of words. The native who lives in the Tundra,—those flat, treeless areas in the northern parts of Russia—possess no words for the colors red, green, blue, purple, etc.; they have the word "colored" for all of them. But the various shades of brown of their cows from which they draw their livelihood, are vital to them for the necessary distinction between

the various animals. Thus, they have invented 37 different words for the various hues of brown.

To the stranger, the tundra seems a lifeless grey-green or brown- or green-brown. He hardly can distinguish more than ten colors in this drab surroundings. The native, on the other hand, who lives continually in the tundra, has some 500 to 800 words and word combinations to specify these colors and their respective shades.

#### **The Color Expert Sees More Colors**

Actually, the painter or any other color expert sees many more colors and hues than the layman. Ask anybody about the color of the wall in the dining room. He will answer: brown, greyish-brown, or grey-violet. But the interior decorator or painter or architect who knows the various colors from long experience and may know also how to combine certain basic colors to create a new color has the exact name for the particular kind of grey or brown or green. Color experts will understand each other by the single word while other people have no way of expressing themselves properly until they are shown examples of the color hues within the broad limits which they are able to specify.

White sun light when sent through a glass prisma, is spread out, and decomposed into its simple constituents. We see then a continuous band of light rays, known as the solar spectrum, and evident to the human eye as a sequence of colors of subtly varying hue. Not all the rays of the solar spectrum are visible to the human eye. The longest rays, called the infrared rays,—as well as the shortest rays, the ultraviolet rays, do not stimulate the human retina. The visible spectrum includes seven (or six colors without indigo) spectral colors: red, orange, yellow, green, blue, indigo and violet. White in this particular case, is actually composed of seven colors.

White, on the other hand, is produced also by a combination of certain colors which are mixed in a certain proportion known to the experts. Always two colors of a particular combination produce the color white,—and those are complementary colors. Such color complements which combine to make white, are yellow and violet, orange and blue, red and blue-green. The eye, however, cannot distinguish any longer these different colors,—and even the painter though he has mixed the two colors previously himself, cannot see anything but the white color.

#### **Limits to Color Sense**

Exact examination has shown that the ability to perceive the different colors is unequally distributed over the retina,—the nervous part of the eye vision. The eye has a certain field of vision; in its center the objects are seen distinctly while the vision is indistinct on the margins of the visual

field. These margins are sensitive only to white and black, and their mixture of grey; the fields for blue and yellow cover the whole area except the margins; the fields for red and green sensation are the smallest, occupying only the central part of the field and covering less than half its surface. The margins are insensitive to color, they distinguish only degrees of light and darkness.

Everyone may find out for himself whether he can distinguish any color in objects which he sees at the margin of his field of vision. He will find out that he is not able to recognize any color in those objects.

There are certain limits to our color sense and our color knowledge. These limits are partly physiological, founded on the nature of the eye and brain and therefore cannot be changed. But these very limits can very well be extended through practice and observation—and that is the reason why painters, architects, interior decorators, etc., have a much better knowledge of colors than the layman has.

#### **Monochrome Rooms**

One color rooms, monochrome rooms, are recommended mainly for the city life. They are supposed to maintain tranquillity and distinction in the hurried everyday life of the city dweller. Coming home to the easy color-flow of a monochromatic room is said to be more soothing for city nerves. Big sharp colors are deemed appropriate for the country,—for the city they seem to be nerve-tearing.

The small rooms of city apartments seem to be larger as well, because "the eye is nowhere stopped by intrusive color-contrasts. As an expert description states, "the living-room of one low-ceilinged apartment is lifted by light sky-blue walls, sea blue curtains, furniture covered with deeper blue; on the floor, a black Bessarabian rug touched with blue and green."

#### **After-Image**

Apparently seeing one color means less trouble to the nerves connected with seeing. Actually our eye rarely sees only one color. There is the important physiological fact of the After-Image. A. H. Munsell has mentioned the classic example of the mother who glanced up from work upon a piece of vivid scarlet cloth, and shrieked at the look on her baby's face,—believing its apparent pallor meant death of the child. Actually the rosy complexion of the baby had not changed, but her fatigued eyes could see no red for the moment, giving only a ghastly mixture of the two remaining sensations, green and blue.

Had the cloth reflected a vivid blue-green, she might have been equally overwhelmed by a contrary illusion that the child was running a high fever.

Every color, or combination of colors has its specific afterimage. When you have looked at green for some time — red will appear as afterimage. You stare at blue for a certain time—yellow will appear for your eyes on a white surface when you turn your eyes to it. The eye, fatigued with looking at one color, is disposed to receive the impression of its complement. Complementary colors are such as when blended together give rise to the perception of whiteness. A painter in a paint shop is looking at red paints; after having seen five or six samples, he begins to complain of the bad color of those subsequently shown to him.

Actually the color is not bad. But his eye, weary of red, no longer receives the impression of it vividly, or as a source of pleasure. Some hundred years ago a color expert, Monsieur Chevreul of Paris, gave this advice to textile men: Let the prudent tradesman not allow ten or eleven red stuffs to be looked at in succession. After about the fifth red material, something green should be submitted for inspection. After the customer has looked at green for some time, he may go on looking at red material," and will be sure to see them to the best advantage.

When we are in a monochrome room or when we see somebody wearing a dress of one color, we cannot help being impressed in a certain manner. **Blue**, for instance, is known to usually have soothing effect on neurotic people and neurasthenics. The office rooms of neurologists and psychotherapists are sometimes painted or decorated in a mild blue in order to produce a relaxing effect with the patients. Melancholic, depressive patients need a more vivid color to feel less depressed. A neurotic woman, despite all kinds of cures, did not improve until finally the despairing doctor suggested to have her whole house redecorated in blue—removing the original bright, supposedly cheerful colors. This did the trick, the mysterious complaints vanished—at least for a long time.

The old colors in that house had contained a good deal of red. **Red** has a stimulating effect on most people and increases the working power of the brain. It is well suited for depressive moods—a woman who feels depressed, might feel a lot better in a red dress. The Color Research Institute of America in Chicago recently reported this strange experience. A well-known professional man, very deeply depressed, decided to commit suicide by self-starvation. At last he was taken to a mental hospital and placed in a special room which was painted in a bright red. Within twenty-four hours, by the power of color alone, his will to live had been awakened and he ate again. Red electric light is used as well to stimulate the depressive feeling and to shy away thoughts of suicide.

H. S. Kahm relates this experience. In one ex-

periment, a group of salesmen had a conference in a red room. They had been asked to leave their watches outside, and after the conference they had to estimate how long it had lasted. The average consensus of opinion was six hours. Actually, it was just half that. In another corresponding experiment in a light blue room, the salesmen thought they were in there a shorter time than they actually were.

#### From Yellow to Purple

**Yellow** is another stimulating color which helps energize the brain. In color therapy it is used in treating colds, paralysis and chronic conditions. It might be preferable not to wear a yellow dress in an airplane: color experts of airlines have stated that air-sickness is induced by a prevalence of yellow and brown, while it is averted by blue and green. Consequently painting and decorating in airplanes tries to avoid yellow and brown.

**Orange** alone is too stimulating in the long run, due to its being a mixture of red and yellow. Only few people like orange painted rooms.

**Green** possesses cooling effects and is useful in the abatement of excitement. It is subconsciously associated with nature and health and counteracts brightness of sunlight.

**Black** is useful for toning strong colors, it is not actually depressing. It is best used in combination with some other color.

**White**, on the other hand, is cheery, it attracts sunlight. But used alone both as dress or in a room, it is cold. White has a stimulating effect when used with red, yellow or orange.

**Brown** is restful and warming—but somewhat depressed when used alone. Best effects are reached when it is combined with orange, yellow and gold.

**Purple** and mauve are sedative, soothing colors, they may induce sleep. Purple is a mixture of red and blue, but it seems that the sedative influence of blue is more important in this combination.

The latter opinion is not unanimous. Dr. William S. Wadsworth of Philadelphia, a physician interested for many years in the study of color effects on the human body and mind,—points out that purple causes the greatest emotional upset though its effect will vary with the individual. He had the opportunity of studying the effects of colors on the professors who came into his office at the University of Pennsylvania. Among these men were found persons who, although emotionally stable in every way, could not endure prolonged exposure to the purple light. Uneasiness and mental restlessness were the consequence.

In using certain colors in rooms we are hardly aware of the physiological foundations of our selection. Still they are the most important factors in our decisions.

# Distinguished Honor Awards Southern California Chapter A. I. A.



## CHANNEL HEIGHTS HOUSING PROJECT San Pedro, California

**RICHARD J. NEUTRA, Architect**

Channel Heights is the largest housing project in the Los Angeles area and one of the largest in the country. It is built on a 165 acre site and is planned at a very low density. This particular site was chosen in spite of its ruggedness because of its proximity to the shipyard and the harbor of San Pedro. The project general, benefits aesthetically from the view onto the ocean and valley, and the housing units themselves are planned and oriented in such a way that each building has an unobstructed view.

In spite of the steep site, it was possible to find room for the total number of dwelling units required. Under ordinary circumstances, the grading problem for such a site would have presented serious obstacles, since the land rises some 285 feet from the East to the West boundary line, and is cut through by precipitous ravines and bisected by a canyon 90 feet deep. Without modern excavation and site-engineering machinery, it would have been impossible to do the amount and kind of terracing that had to be done. Many types and



*Photos  
by  
Julius  
Shulman*



**HONOR AWARD:**

NAME: Channel Heights Housing Project.

OWNER: Housing Authority of the City of Los Angeles.

LOCATION: San Pedro.

YEAR: 1943

CONTRACTOR: Baruch Corporation.

ARCHITECT: Richard J. Neutra—Lewis E. Wilson, Consultant.

GROUP: IX.

This design should give a death blow to the

argument that Federal Housing must look like a warehouse, institution or barracks.

A brilliant site plan with elements of repetition so carefully held in balance with the landscape and scale of buildings as to give a great sense of variety. The interiors, not less than the exteriors, reveal the same genius for forceful and dynamic architecture.

In the interiors, the power of external architecture has been replaced with a quality of charm and tenderness different to achieve in less strenuous circumstances than a large scale war housing project.

sizes of tractors were used. In order to minimize erosion, the grading was done entirely by cutting—no fill was used. In the pre-machine age the site plan and hillside space budget would have required a fundamentally different approach. The present and actual concept and layout was conditioned by the contemporary set of tools.

The drainage of the site was designed in such a way that the storm water was directed away from bankheads into the motor courts and service drives and thence over the grounds to dissipate itself in the free areas. The principal project streets are planned to follow the natural land contours, thus avoiding sharp grades and unnecessary excavation. The utility lines, municipal water for example, are however not laid along these streets, but through free areas. Hydrants spotted at water mains are provided in the most strategic places for fire fighting and sprinkling of sodded areas

and gardens. This independent utility layout is designed for greater economy of critical materials and perpetual accessibility without breaking up pavements.

A well-landscaped public park, rarely used in the past, adjoins the project and now becomes a primary asset. Its situation is such that it relates quite naturally to the project site, and consequently there is a continuous flow of free space between the park and through the project.

Electrically lit tunnels and underpasses for pedestrians have been built under the main project street at two points. Thus the tenants can walk safely from one part of the project to the other, and there is a continuous unobstructed flow of foot traffic between the residential to the recreational area and the central free space.

Complete community facilities have been plan-



ned for the project and thus far a community building and child care center, with indoor and outdoor play space, a garden craft center, and a 10,000 square foot business and market center, a firehouse, utility and storage building have been built. An infirmary and an elementary school are

planned but not yet under construction. The garden craft center is of particular interest as an experiment. A plant dispensary, green nursery and lath house have been provided, and here the tenants who are interested can learn all about gardening and the growing of plants.



# KELTON APARTMENTS

## WESTWOOD, CALIFORNIA

**RICHARD J. NEUTRA, Architect**

A multiple dwelling with careful use of controlled views and of outdoor living spaces, containing two types of apartments: two-bedroom units, and a one room bachelor unit. This latter one has a cozy social bay with seating arrangement at a fireplace, a bay for rest, an alcove separable from the main room by a 5'-6" high shelf unit and a movable flexible screen. Also there is a small bathroom and ample cupboard space, and an outdoor covered porch.

The lower two bedroom apartment, reached by

a well separated entrance has a large living room with dining bay. Its amply dimensioned, roofed front terrace connects with a private patio. Its large windows look over pine tree tops and far-away hills. A carefully laid out kitchen and utility bay with ample cupboard space, two bedrooms and a bath complete this lower apartment.

The upper one, reached by a thoroughly segregated exterior stair has a similar arrangement with an addition of a fireplace in living room and a large terrace off the second bedroom. The magnifi-

(See Page 19)

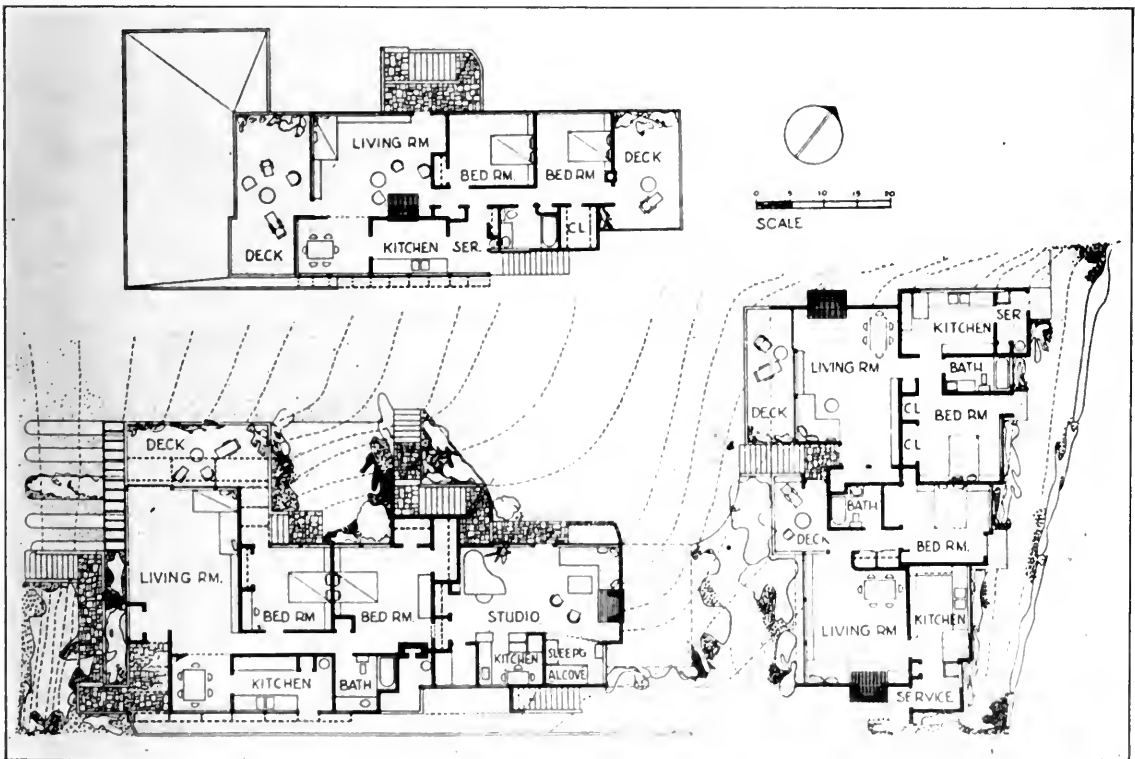



#### **HONOR AWARD:**

NAME: Kelton Apartments.

OWNER: Mr. Alfred Niedermann.

LOCATION: 644 Kelton Ave., Westwood.

YEAR: 1941.

CONTRACTOR: Eric Nelson.

ARCHITECT: Richard J. Neutra.

GROUP: II.

This interesting small apartment house is a fresh clean solution to the apartment dwelling on a small, rather difficult lot. Each apartment is pro-

vided with either a generous deck or garden space, which has been regarded by the designer as an essential requirement. This outdoor feature of living and building is something about which there is much talk, but too little done.

While the architecture is recognizable as the famous Neutra idiom, rigid intellectual design has been transformed with an ever increasing human quality. Glass walls are still conspicuously in evidence, but are balanced by the substantial character of interior walls.

Good planning, a cheerful general aspect to the architecture as a whole, plus frequent bits of genuine charm, place these apartments in a class by themselves.



. . . DISTINGUISHED HONOR AWARDS



(From Page 17)

cent view from this upper apartment is utilized to full advantage.

The walls have washable sanitas finish, the dining bay a Philippine mahogany wainscot.

Metal sash, continuously sliding curtaining from Kirsch metal curtain tracks, flush surface, hollow core doors, white metalcased drainboards, Schlage Locks give durable quality to interior finish.





# House for John B. Nesbitt

## Brentwood, California

**RICHARD J. NEUTRA, Architect**

Together with a number of other people, the owner and the architect felt that Pearl Harbor will be remembered as the end of the post-Victorian, tax-free era, of North America. With many mutations in the making during that era, individualism turned slowly from a "dominant" into a romantic

"recessive," (to use a biological parallel by Mr. Lewis Mumford).

In spite of all its boastings that era also had been characterized by a strange scarcity of truly contemporary building materials and constructions, and this shortage reached a monumental ultimate



"Last of An Era House"



## DISTINGUISHED HONOR AWARDS . . .

climax during the American war participation years. The "Last of an Era House" of brick and redwood, started and finished in 1942, expresses this and a few other things as a queer historical memento to postwar generations.

An owner of a spacious mansion would now sell, and build a four-room house with a detachable, two-room guest house for good measure; that, with domestic servants having drifted to the aircraft plant, the owner's wife would do the house-keeping and childraising; that with gas and tires largely gone, the occupants of house and garden—now occupy them most of the time.

Maintenance services left by OPA with the sky as the ceiling, the most indestructible old-fashioned, uncritical materials are used for furniture, walls and floors: sturdy redwood and hard brick, materials which after the war may be highly original in midst of the stunning products of a 1947-building industry.

Playful leisure between foliage, flowers, lath house and pools, a dimmed reflection of a long, lusty, little burdened California peace, flavor this "Last-of-an-Era-House." Still, there may be in it an arrow or two pointing into a future of fresh starts.





**DISTINGUISHED HONOR AWARD:**

NAME: Residence.

OWNER: Mr. John Nesbitt.

LOCATION: 414 Avondale Ave., Brentwood.

YEAR: 1942.

CONTRACTOR: Eric Nelson.

ARCHITECT: Richard J. Neutra.

GROUP: I.

This house must be seen to be appreciated although it was singled out as a performance of rare accomplishment from the plan and photographs, prior to visiting the premises.

Well placed upon a generous lot in the City, the site planning and landscaping are of unusual

quality. An air of haunting enchantment hangs over the place, created in no small measure by the lush planting which has been selected and placed with remarkable skill.

Imagination abounds everywhere, but it is the imagination of the trained designer who knows just what he is doing, mature, rich, sensitive. Urban sophistication and culture refinement have been expressed in terms of almost rustic simplicity, —a juxtaposition of contrasting moods that is, in part, the key to the tantalizing delightfulness of the house.

This is one of those works of architecture that evades analysis, each time you think you have found the secret of its beauty, it has eluded you again.

See: **Note** following Baldwin Hills Village.

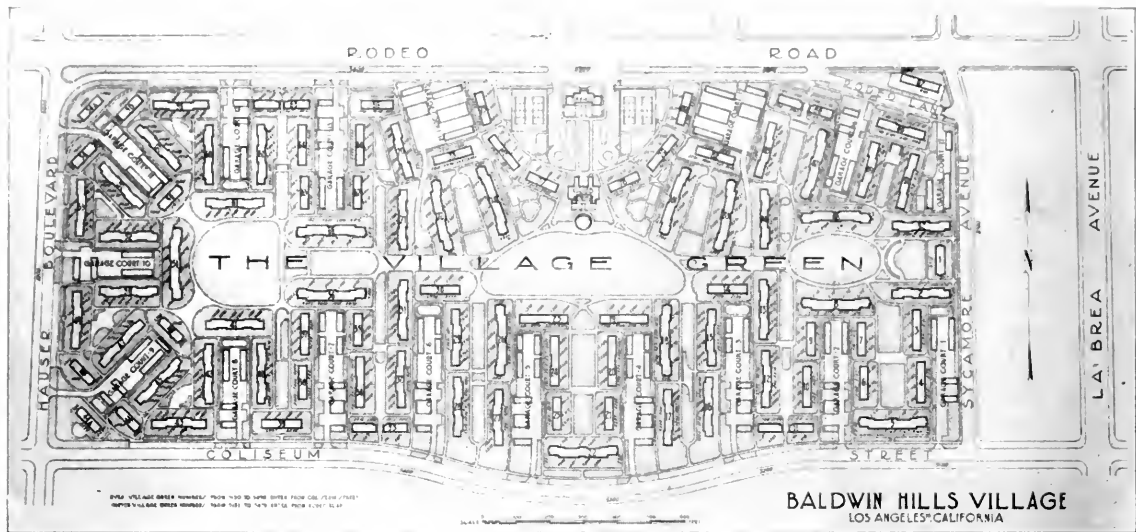

# BALDWIN HILLS VILLAGE

LOS ANGELES, CALIFORNIA

**REGINALD D. JOHNSON, Architect**

**WILSON MERRILL, ROBERT E. ALEXANDER  
Associated**

and

**CLARENCE S. STEIN, Consultant**



Typical  
Home

Beautiful  
Surroundings



Landscaped

## DISTINGUISHED HONOR AWARDS . . .

### DISTINGUISHED HONOR AWARD:

NAME: Baldwin Hills Village.

OWNER: Rancho Cienga Properties Inc.

LOCATION: 5300 Rodeo Road.

CONTRACTOR: Baruch Corporation.

ARCHITECT: Reginald D. Johnson — Wilson, Merrill and Alexander.

CONSULTING ARCHITECT: Clarence S. Stein.

LANDSCAPE ARCHITECT: Fred Barlow.

GROUP: IX and X.

This project was particularly commended for the brilliant site plan, which was responsible for the distinguished honor award.

A mediocre site, sloping to provide good drainage, was transformed by skillful planning and landscaping into a distinguished living environment. With a fine balance of variety and repetition, the plan creates a feeling of spaciousness and repose. Although the principle of axial planning was extensively used, it was used with such skill as to avoid institutional or monumental character. Vision from any one point is limited, enhancing the friendly and hospitable atmosphere. Walking through the grounds from court to court, the charm and variety of the design appeared to come from skillful interweaving of the site plan and landscaping with the pleasing masses of the structures

themselves rather than from variety of architectural detail.

Service areas have been strategically located for convenience, and subdued in relation to living areas. Dwelling units are provided with a patio or balcony for outdoor living. The project lacks positive architectural color, possibly due to war-time painting restrictions; similarly it seemed more positive color could be used to advantage in the planting.

Here is a living pattern worthy of detail study in relation to future housing problems, private or public.

See: **Note** below.

---

### **NOTE: ON THE NESBITT HOUSE AND BALDWIN HILLS VILLAGE.**

These two projects, each an achievement of mature talent, can be compared directly. Each has a distinguished site plan, and arrives as a piece of distinguished architecture by benefit of site plan and landscaping as much as by architecture itself.

Baldwin Hills Village is a large project, illustrative of social problems of the day, and collective living. On the other hand, the Nesbitt house is highly individualistic. Neither scheme offends its neighbors, and each fits into the Community.

Another project of Richard Neutra, Channel Dwellings, received an honor award in this Competition. It is interesting to note that an honor award was given to Reginald Johnson in 1927.







# Sound Motion Pictures

## For Schools and Auditoriums

By JOHN A. HOWLAND

From time to time, and oftener from now on, the architect is called upon to provide classrooms and auditoriums for schools, suited to the projection of sound motion pictures and slidefilms, which are used to speed up teaching, aid the instructor and entertain. Not only will **educational** architecture make these demands upon the profession, but films have become so important a part of cultural, social, community life and learning that churches, clubs, hospitals, public halls and even homes are to have provision for their use.

Of course, the proper installation of an auditorium or other room adapted to the projection of sound pictures is more in the field of electronics than in that of form and design. The projection room is a job for the electrical man, the sound engineer. At the same time, the architect must clearly realize principles of construction and layout in order to make adequate aural and visual presentations and to get the quality standards today set by commercial motion picture theaters. After

all it is the motion picture theater which establishes the public's concept of picture screen quality though it is not always possible to fully achieve that quality in the non-theatrical structure.

### Basic Knowledge

What basic knowledge will be most useful to the architect confronted with a problem of this kind?

First, he will want to know the purpose and **objectives** of visual aids and cultural production; second, peculiar acoustic treatment of rooms and auditoriums where pictures are to be shown. This knowledge especially applies to the **new** building, and here let it be said that, while most of the data required by the architect in this field will apply primarily to the **school** classroom, the **identical** principles apply with equal authority to club, hospital or home.

Today visuals are used with an efficiency never dreamed of a few years ago. Great advances

were made during the war not only in producing better teaching and training films but likewise in devising better techniques of their utility, better methods and conditions of projecting both sound and vision.

Of course, the first thing the architect will consider is the seating arrangement of the room he is to design, based upon the population and projection needs of the building, institution or organization. To satisfy the educational requirements of clear vision, it is recommended that seating be arranged depending upon the shape of the room used. If the room is square, a matte screen, which will give a wide viewing angle of approximately 30 degrees, should be used. If the room is oblong, a beaded screen, with a viewing angle of 20 degrees, is recommended.

The beaded screen reflects the light in a narrow beam and as a result has a comparatively high surface brightness. Because of this greater brightness, the first row of seats used should not be so close to the screen as when a matte screen is used. Both rectangular and square rooms have about the same seating capacity for a given total floor area. It is well to give some thought to the provision of ample ventilation throughout the length of the programs, since the shutting off of light at times also means the obstruction of air entrances.

After the seating arrangement has been completed, it is recommended that the screen width be determined by the distance from the screen to the last row of seats. The screen width should be about one-sixth of this distance. For the matte screen, the nearest row should be about twice the width of the screen from the screen. For the beaded screen, the nearest row should be two and one-half times the width of the screen.

It is recommended that the screen be located on the center front wall, with the bottom of the screen about four or five feet from the floor. The screen should be of a roller "map" type, permanently mounted on the wall to provide for immediate and convenient use. Some designers are planning for a sliding panel in the blackboard with a permanently mounted screen behind it. Such installations permit the screen to be recessed in the wall to give a "shadow box" effect for darkening purposes.

Regarding the matter of current and outlets, the architect will need to realize what modern projection calls for in this respect in order to make for projection efficiency. To provide a permanent electrical wiring installation, it is recommended that the projector be located at the center of the rear wall with the loud speaker as close to the side of the screen as practicable. If the front wall

is entirely devoted to blackboard space, the speaker may be mounted in either front corner of the room.

To supply 115-volt a. c. to the equipment, it is recommended that a duplex convenience outlet be installed in the front and rear walls below the positions to be occupied by the projector and speaker respectively. The outlet at the front of the room is recommended because booster amplifiers may be used with some projectors, or speakers may have their own field power supply. The outlet at the rear of the room provides power for the projector and amplifier units. These outlets will, of course, also be available for other use when the sound-picture equipment is not being used. The wiring to the projector outlet should be capable of carrying 20 amperes with very low voltage drop, and therefore should be 10-gauge copper conductor rubber covered. This line should be fused for 20 amperes. The speaker outlet for 115-volt a. c. should be wired and fused for 15 amperes.

To feed the electrical sound energy from the rear to the front of the room, it is recommended that three-quarter inch thin-wall conduit be permanently installed in the wall or floor, thereby connecting the front and rear-wall sockets. Sockets of the Howard B. Jones type S406-WP (or B&H A2072 equivalent) are recommended for this purpose.

To connect the two outlets, five No. 14 solid conductors with 600-volt rubber insulation of the type normally used in building wiring are recommended. To systematize the wiring between the sockets, 14-gauge rubber covered wire may be obtained in the following colors: white, black, green, yellow, and red.

The usual defects of auditoriums are three—echo, dead spots and reverberation. In the usual sense of the term, echo means a definite or articulate repetition of a sound after an interval at least equal to the total duration of the sound that is being repeated, while reverberation means a confused or inarticulate prolongation of the sound.

Echo is always a bad feature in a hall; reverberation, on the other hand, is desirable up to a certain point; only in excess is it an evil. Of the two, echo is the more difficult to remove; prevention by foresight in construction, aided by expert advice, if necessary, is the best plan.

Echo arises by regular reflection of sound from smooth walls, ceilings, or proscenium arches just as a mirror may reflect a beam of light without scattering it. If, however, the surface of the mirror be roughened the reflected light will be diffused in all directions; and if the walls and ceilings of a

room be similarly irregular (on a sufficiently large scale) the reflected sound will be scattered, broken up, and its definite or articulate character destroyed. In this case we have what is called reverberation.

The lapse of time before an echo is heard is due to the fact that the reflected sound has traveled a longer path than the sound which comes directly from the source. This difference of path may be such as to cause much mischief. If it amounts to 50 feet or more, the reflected sound of a spoken syllable or note of music may arrive at the ear at the same moment as a later syllable or note which has traveled by the direct path, and so cause confusion.

Smooth, hard-finished walls, such as the usual plastered type, are excellent reflectors of sound and are consequently likely to produce echo. It becomes of importance, therefore, to break up such surfaces so as to produce irregular distribution of the reflected sound.

Dead spots and sound foci (areas where volume is excessive as compared with the general volume level throughout the room) occur as a consequence of echo-producing conditions. Sound travels through the air as alternate waves toward the center of the auditorium and less toward the side walls, the ceiling, and the floor. There are directional baffles of two types. A small circular type is available, approximately 18" in diameter at the outer end, which extends about 11" forward from the front of the speaker case. Directional baffles will seldom be required in the smaller auditoriums.

For permanent installations, a larger type of baffle is available, the measurements of which are as follows:

- Length 50"
- Width at speaker compartment 15"
- Height of speaker compartment 15"
- Overall size of horn at widest end 38" x 25"

The regular speaker case is not used when the speaker is mounted in this large baffle.

---

### **PRIZES FOR CHURCH DESIGN**

The Interdenominational Bureau of Architecture has appropriated \$500 to be used to stimulate church design by students of schools of architecture in the United States.

A first prize of \$100 will be given the student in any American school of architecture who presents, in the opinion of the jury, the best church plan and design. Other prizes of \$75, \$50, \$35, and several of \$25, as well as honorable mentions will be awarded.

The competition will close January 3, 1948, and the designs will be displayed at the North American Conference on Church Architecture in New

York on the same date.

Students and faculty members desiring further information can get in touch with Elbert M. Conover, Interdenominational Bureau of Architecture, 297 Fourth Ave., New York 10, New York.

---

### **CLAY BRICK**

George E. Solnar, Jr., has been appointed manager of the Clay Brick Manufacturers Association of Northern California, the organization's board of directors announced recently. His job will be to promote the sale of common and face brick for residential and commercial building, also to assist architects, engineers, contractors, and builders and others interested in the use of brick.

---

### **APPOINTED PACIFIC COAST MANAGER**

S. H. Harrison, a native of Tacoma, Washington, has been appointed manager of the Industrial Division, Westinghouse Electric Corporation, Pacific Coast district. He will make his headquarters in San Francisco.

A Stanford University graduate, Harrison served at East Pittsburgh, Pa., and Seattle, Washington, prior to his transfer to San Francisco.

---

### **FORD EXHIBIT**

The Ford Motor Company held a parts purchasing exhibit in San Francisco during February, at which time they purchased about \$50 million in parts requirements from California manufacturers.

---

### **DIVERGENCE**

The mortgage finance committee of the National Association of Home Builders is endeavoring to reach a solution of the impasse caused by the divergence between FHA and Veterans' Administration appraisals on veterans homes.

Veterans have been deprived of homes in many instances because of the variance in appraisals of from \$300 to \$500 between the valuations set by the two government agencies.

---

### **JET PROPLUSION COURSE**

A course in "Jet Propulsion Applications to High Speed Transportation" is currently being offered by the University of California Extension, Los Angeles. The instructor is Dr. Robert A. Cornog, research engineer at the Northrop Aircraft Company.

The class is designed as directed group study for upper division students in the field.

---

### **SCHOOL ADDITION**

Bonds have been voted for a \$365,000 addition to the Jordan Grammar School at Gilroy, Calif. Architect not yet selected.

# Westinghouse San Francisco Office Building



The Westinghouse Electric Corporation has acquired a long term lease on a three-story building at 410 Bush St., San Francisco. Chas. A. Dostal, Vice President in charge of the corporation's Pacific Coast District, announced recently. Work of altering the structure to provide modern, centrally located quarters for district and local headquarters offices of the company and many of its major divisions is under way.

"When completed, about July 1, the building will provide 40,000 square feet of space and will fill a long need for consolidation, in one loca-

tion, of the personnel of many of our departments and divisions," Mr. Dostal said. "For years it was necessary for these groups to maintain offices in six widely scattered downtown buildings. The move will enable our divisions to more effectively serve this area and guide Westinghouse activities throughout the Pacific District."

Two important branches of the company will not be affected. The Westinghouse Electric Appliance Division will continue to occupy expanded offices and display rooms in the Western Merchandise Mart, 1355 Market St. The Westinghouse Electric Supply Company will continue at its present location, 260 Fifth St.

## Building Completely Redesigned

The Bush St. building, formerly a parking garage, has been completely redesigned by Albert F. Roller, San Francisco architect. The interior will be modernized from basement to roof, providing spacious light, well ventilated offices and general work areas, basement storage space for company cars, and a roof lunch and sun room. The entrance lobby has been attractively conceived in the use of color, hardwoods and shadowboxes for the display of the company's smaller products. The exterior will be executed in ceramic veneers and cement plaster. General contractors are Barrett & Hilp, San Francisco.

Street floor will house offices of the Westinghouse Lamp, X-ray and Elevator Divisions as well as those of the B. F. Sturtevant Company, Division of Westinghouse Electric. Apparatus sales department personnel and activities will occupy the entire second floor. The Pacific Coast District executive offices will be located on the third floor, with those of the engineering and service, sales promotion, treasury and public relations departments and the Westinghouse Electric International Company.

Extending from Bush St. to Pine St., the building is 215 feet long and 40 feet wide.

## KITCHEN JEWELRY!



**STANLEY**

*Cabinet Hardware*

Mayfair Pattern, 5 Other Handsome Patterns

This new line, styled by nationally noted industrial designers, is the result of years of research and test by the Stanley Engineering Department to make cabinet hardware smoother working, longer lasting and easier to install.

Specify it with the full assurance that you are recommending the best. The Stanley Works, New Britain, Conn.

**BLUE RIBBON DESIGN**





# A. I. A.

American Institute



# ACTIVITIES

of Architects

## Arizona Chapter:

James Macmillan, President; Arthur T. Brown, Secretary,  
740 N. Country Club Road, Tucson, Arizona.

## Central Valley of California:

Herbert E. Goodpastor, President; Frank V. Mayo, Secretary,  
307 Exchange Building, Stockton 2, California.

## Colorado Chapter:

Raymond H. Ervin, President; James M. Hunter, Secretary,  
2049 Broadway, Boulder, Colorado.

## Montana Chapter:

Ralph H. Cushing, President; H. C. Cheever, Secretary,  
Montana State College, Bozeman, Montana.

## Northern California Chapter:

Hervey P. Clark, President; Lester Hurd, Vice-President;  
Ralph Pollack, Secretary; William C. Ambrose, Treasurer;  
605 Market Street, San Francisco.

## Oregon Chapter:

Francis Jacobberger, President; J. D. Annand, Secretary,  
401 Central Building, Portland 5, Oregon.

## San Diego Chapter (California):

H. Louis Bodmer, President; Louis J. Gill, Secretary, 203  
Granger Building, San Diego, California.

## Santa Barbara Chapter (California):

Roy C. Wilson, President; Miss Lutah M. Riggs, Secretary,  
240 Middle Road, Santa Barbara, California.

## CALIFORNIA COUNCIL OF ARCHITECTS

Vincent Palmer, President; Andrew Hass, Vice-President;  
A. C. Martin, Jr., Secretary-Treasurer; 369 Pine  
St., San Francisco 4.

## Southern California Chapter:

Adrian Wilson, President; A. C. Martin, Jr., Vice President;  
Walter L. Reichardt, Secretary; George E. Gable, Treasurer;  
Chapter Headquarters, 3757 Wilshire Blvd., Los Angeles 5,  
California.

## Spokane Chapter (Washington):

Noel E. Thomson, President; Kenneth D. Storment, Secretary,  
Hutton Building, Spokane, Washington.

## Utah Chapter:

George Cannon Young, President; Theodore R. Pope, Secretary,  
29 South State Street, Salt Lake City 1, Utah.

## Washington State Chapter:

George W. Stoddard, President; Stephen H. Richardson,  
Secretary, 516 Central Bank Building, Seattle 4, Washington.

## Hawaii Chapter:

Kenneth W. Roehrig, President; James Morrison, Secretary,  
334 Federal Bldg., Honolulu, T. H.

## WASHINGTON STATE CHAPTER, AIA

Winner of the \$10 competition for the best cover design for the 1947 Small Homes Plan Bureau booklet was Wendell Lovett, senior student in architectural design. The award was made, the jury states, for "an abstract design of dignified nature" and was the best, in its opinion, of many excellent entries.

\* \* \*

Reservations are being taken for an architects' bowling league expected to start in September for both architects and draftsmen.

Six teams of five men each is contemplated, and a one-a-week play tentatively decided upon.

\* \* \*

Ebert and McFarland of the Safety Division, State Dept. of Labor, spoke on "Safety Regulations" at a recent meeting of the Engineers Club. Their talks touched principally on safety methods for garages and industrial buildings.

A discussion period followed the talks.

\* \* \*

"A Pharaoh's Phollies," the architects' costume ball, was held at the Inglewood Country Club on the evening of February 21st.

## SOUTHERN CALIFORNIA CHAPTER, AIA

Newly installed President Adrian Wilson, in announcing chapter policy for the coming year, spoke of the need of eliminating government bureaucracy, particularly where it is hampering private enterprise. He favors further decontrols and high production of small houses.

Although opposed to the W. E. T. Bill, Adrian voiced the opinion that some public housing may

be necessary. He also advocated a uniform building code for state and nation, a greater interest on the part of the architect in civic planning, urban redevelopment and public relations.

**DISTINGUISHED GUESTS:** Guests who attended the recent meeting of the chapter included: Richard W. Ware, president of the Structural Engineers Association of Southern California; Harry J. McClean, president of the Professional Coordinating Council; Carl Bush, assistant general manager of the Los Angeles Downtown Business Men's Association; Vern Huck, 1st vice-president, Building Contractor's Association; John L. Hall, president, Producers' Council, Southern California chapter; C. R. Compton, president, Los Angeles Section, A. S. C. E.; and Earl T. Heitschidh, director and chairman, Construction Industries Committee of the Los Angeles Chamber of Commerce.

\* \* \*

The Gold Medal of the American Institute of Architects for 1947 will be awarded to Eliel Saarinen, well-known architect of Bloomfield Hills, Michigan, James R. Edmunds, Jr., AIA president, has announced.

The medal is awarded in recognition of the highest service to the profession of architecture for the year.

An industry meeting called by the Federal Housing Administration, held recently at the Embassy Hotel, Los Angeles, was well attended by architects, who heard a detailed explanation of the newly liberalized terms of mortgage insurance.

New terms consist of longer amortization periods,

(See Page 34)

# WITH THE ENGINEERS

Structural Engineers Association of Northern California

William W. Moore, President; John A. Blume, Vice President; Franklin P. Ulrich, Sec.-Treas.; Offices 214 Old Mint Bldg., San Francisco, Phone GArtfield 3890. DIRECTORS, Mark Falk, M. V. Pregnoff, and R. D. Dewell.

American Society of Civil Engineers San Francisco Section

Theodore P. Dresser, Jr., President; Leon H. Nishkian and Sidney T. Harding, Vice Presidents; John E. Rinne, Secretary-Treasurer; 225 Bush St., San Francisco 20.

Puget Sound Council (Washington) Engineering & Technical Societies

R. E. Kistler, A. I. E. E., Chairman; A. L. Miller, A.S.C.E., Vice-Chairman; L. B. Cooper, A.S.M.E., Secretary; B. A. Travis, I.E.S., Treasurer; Offices, L. B. Cooper, c/o University of Washington, Seattle 5, Washington.

## SAN FRANCISCO SECTION AMERICAN SOCIETY OF CIVIL ENGINEERS

Fred J. Grumm, assistant state highway engineer spoke on "The California State Highway system: Its Present Condition; Its Needed Improvement" at a recent meeting.

His talk was especially timely in view of the expanded state highway program now under consideration by the California Legislature at Sacramento. Various points were illustrated by the use of charts.

**FOR BETTER SERVICE**  
*Remember that*  
**KRAFTILE is**  
**WESTERN HEADQUARTERS**  
**FOR**

- |                                 |  |
|---------------------------------|--|
| ▶ GLAZED Structural Wall Units  | ▶ ACID Brick                             |
| ▶ PATIO Tile                    | ▶ ACID-PROOF Jointing Compounds          |
| ▶ QUARRY Tile                   | ▶ ACID-PROOF Floor and Tank Construction |
| ▶ SWIMMING POOL Overflow Gutter | ▶ ACID-PROOF Coatings                    |



- |                                    |                       |
|------------------------------------|-----------------------|
| ▶ QUONSET Packaged Steel Buildings | ▶ STRAN-STEEL Framing |
|------------------------------------|-----------------------|

For complete information and prompt service, phone or write

**KRAFTILE COMPANY**

NILES, CALIFORNIA NILES 3611

SAN FRANCISCO: 50 Hawthorne Street — DOUGLAS 3780

LOS ANGELES: 316 E. Commercial Street — MUTUAL 2411

## SPEAKERS' CLUB RESUMES

The Engineers Speakers Club has resumed meeting after the holiday recess. Meetings are held every Monday noon at John's Pearl Oyster House.

**MEMBERSHIP:** New subscribing members are: Ralph A. Beebe, Francis H. Davis, Chester C. Fisk, Robert Hawxhurst, Jr., I. L. Johnson, William H. Jervis, Samuel N. Karrick, Hans Kramer, Einar T. Larsen, Paul B. Lee, Louis A. McAtee, George W. Rathjens, Henry L. Thackwell, Ralph R. Tinkham, Sanders Van Auken, Allan J. Wagner, DeWitt C. Wolfe, and Ludson D. Worsham.

The first 1947 meeting of Junior Forum was held recently at the Hon Yuen Cafe, San Francisco. The program included competitive presentation of technical papers prepared by students of Stanford, Santa Clara and University of California.

**1947 SECTION COMMITTEES:** These are the chairmen of the 1947 committees:

Program, Robert D. Dewell; Excursion, F. M. Misch; Professional Conduct, E. Elmore Hutchinson; Professional Objectives, R. G. Wadsworth; Public Relations, Frank G. White; Publications, E. F. Levy; Membership, W. L. Dickey; Reception, G. D. Whittle; Legislative, F. E. Bonner; Registration, J. G. Wright; Tests on Exposition Buildings, H. B. Hammill; Sanitary Engineering, S. P. Duckel; Auditing, G. C. Green; Juniors, A. S. Niles; Convention, L. H. Anderson; Employment Conditions, C. A. Lauenstein; Building Code, A. W. Earl; Soil Mechanics and Foundations, C. H. Lee.

## STRUCTURAL ENGINEERS ASSOCIATION NO. CALIF. CHAPTER

Many association members in private practice are seeking additional floor space and would employ more draftsmen if they were available, a recent survey indicated.

L. H. Nishkian and B. H. Nishkian have announced a new combination of father and son in the practice of consulting engineering at their present address at 1045 Sansome, San Francisco.

The Advisory Committee held a meeting recently at which plans for the coming months were discussed.

The proposed new draft of the San Francisco building code was presented to the Board of Supervisors recently. There were some objections and the code was referred to the Judiciary Committee.

An advisory board from architectural engineering, and other interested groups, is considering the controversial points in the code.

"Some Engineering Phases of Future Building Construction in the West" was discussed at a recent meeting of the association. Eighty-six members—the largest turnout in the history of the association—attended the meeting. Representatives from a number of other engineering societies were also present.

**STRUCTURAL ENGINEERS ASSOCIATION  
SOUTHERN CALIFORNIA CHAPTER**

Ellis Wing Taylor, chairman of the structural engineers Legislative Committee, discussed the effects of the State Housing Act on the fire hazard situation, at a recent meeting of the chapter.

\* \* \*

The Association endorsed two amendments to the Los Angeles City Chapter which delegate to the Board of Building and Safety the administration and maintenance of zoning ordinances as well as authority to make minor changes in the interpretation of the law.

This is in keeping with recommendations made by the Legislative Committee that all matters having to do with the building industry be consolidated under the Dept. of Building and Safety.

\* \* \*

**NEW COURSES OFFERED:** A new course in engineering, "The Traverse Method in Stress Analysis," offered by the University of California Extension, was announced by R. W. Stewart. The basis of the method is the computation of bending moments in continuous structures by the use of geometrical traverse of the elastic curve, as developed by Stewart.

\* \* \*

The growing importance of light-weight concrete aggregates to the building industry of Southern California was emphasized at a recent meeting of the Structural Engineers Association of Southern California held in Los Angeles.

In addition to the extensive use of aggregates in precast concrete masonry units for commercial and residential building, some of the aggregates are now being used for insulating, fireproofing, structural and refractory concrete.

Structural engineer Paul Jeffers described the use of lightweight concrete for fireproofing the steel frame of the Southern California Telephone Company's Grand Avenue Toll Building in Los Angeles. He also spoke of the application of structural concrete in walls and floor slabs.

A description of the manufacture of vericulite from natural mica was given by A. M. Dinkfield, research engineer for Gladding, McBean & Co.

This mica is subjected to intense heat which expands the cellular structure into millions of tiny air cells, giving it lightness and insulating effi-

(See Page 39)

# A builder is judged by his buildings



A builder has no finer advertisement nor more severe critic than his own buildings. He establishes a reputation by thinking of the future, planning and building for comfort and convenience for years to come. One way to increase

the value of homes and buildings is to specify built-in telephone outlets during construction. Here's why!

## Built-in telephone



outlets add little to building costs... much to building value.

The location of the telephone can be changed or additional telephones may be added in the future



without tearing up the flooring or running wires along baseboards.

The convenience of well placed telephone outlets will be appreciated year after year.



Call or dial local Telephone Business Office.  
Ask for Architects' and Builders' Service.

## The Pacific Telephone and Telegraph Co.





Job—Oriental Rug Co., Vernon, Calif. • Engineers—Mackintosh & Mackintosh • Contractors—Contracting Engineers Co. • Truss Construction—American Bowstring, 40' span, 9 trusses, 17' apart

## *Efficient Design* **RAPID INSTALLATION**

No "fuss or feathers" to this, a typical American Roof Truss installation. The installation crew pulls up on the appointed day . . . a few hours later the entire truss system—a system designed to accommodate seismic stresses and other conditions is installed.

Ready now are American's complete western facilities, its quarter century background and design and installation of **roof trusses exclusively**. Phone or write today.

Register now to receive your copy of valuable Roof Truss data, soon off the press.



## A. I. A. ACTIVITIES

(From Page 31)

lower interest rates, tax assistance, and more up-to-date cost appraisals.

The revised procedures are designed to encourage private investors to enter the rental housing field in greater numbers.

Architects of the San Fernando Valley recently signified their desire to join the chapter by signing an Agreement of Affiliation, which was received from J. Robert Harris, secretary of the group.

The Chapter welcomes them and invites their participation in meetings.

## CALIFORNIA COUNCIL OF ARCHITECTS

A legislative program providing for more representative direction of the State Department of Public Works was endorsed by the California Council of Architects at its annual meeting which was held at the Hotel Mar Monte, Santa Barbara, Friday through Sunday, February 14th-16th.

Other measures adopted dealt with uniformity of building ordinances between state and city governments, the abolishing of overlapping codes and the coordination of the entire construction industry in planning its objectives in the present session of the state legislature.

Donald Kirby, Architect and chairman of the Builders' Exchange Legislative Committee reported on bills recently introduced by Assemblymen supporting the construction industries program.

The Council met briefly with Albert C. Wollenberg, Edward M. Gaffney, and Thomas W. Caldecott, Assemblymen from the San Francisco Bay Area who were spending the week end as guests of the Santa Barbara Chamber of Commerce.

Dr. Charles Bursch, Director of the Division of School House Planning and his assistant, Charles D. Gibson from Los Angeles, met with Chairman John Lyon Reid of the committee on School House Planning to discuss ways and means of closer cooperation between the architect and the state in this field. Assisting Reid were architects, Henry Wright of Los Angeles, Frank Mayo of Stockton, Sam W. Hammil of San Diego and Philip Daniels of Santa Maria. Architect John Rex of Hollywood was appointed to this committee, which will meet again on March 7th.

Installation of new council members followed the business meeting. The council now includes the following architects. From the Los Angeles chapter of A. I. A.: Adrian Wilson, Earl Heitschmidt, John Rex, Albert Martin, Jr., Vincent Palm-er and George Gable. From San Diego: Harry



Whitely and Wm. Lodge. From the Central Valley Chapter of California: Herbert Goodpastor and Peter Sala. From Santa Barbara: Philip Daniels and Robert Hoy. From the Northern California Chapter: John Bolles, Hervey Parke Clark, Andrew Hess, and Norman K. Blanchard.

Council officers for the coming year are Vincent Palmer, President; Andrew Hess, Vice President; A. C. Martin Jr., Secretary-Treasurer; with John Bolles as Chairman of the Legislative Committee; and Norman K. Blanchard as Chairman of the Public Relations Committee.

Outgoing council members who attended and were commended for their services during the past year were Charles Matcham, Past President of the Los Angeles Chapter A. I. A. and James Mitchell, Secretary-Treasurer of the Council.

### G. I. ARCHITECTS IN TRAINING

The Pittsburgh Chapter of the American Institute of Architects was the sponsor of the first professional group to be organized under the apprentice training feature of the G. I. Bill, when it arranged to organize a special evening class in architecture at the Carnegie Institute of Technology at Pittsburgh, Pa.

The group consists of 14 veterans employed in architect's offices in the area.

### MORE NON-HOUSING CONSTRUCTION

Action of the Office of Temporary Controls in raising the limitation on the volume of non-housing construction is most encouraging to the architectural profession, says James R. Edmunds, Jr., President of the American Institute of Architects.

"An increase of \$35 million a week in commercial, industrial and public construction will be permitted to get under way, and will result in the building of many essential structures," Edmunds said.

### GRAMMAR SCHOOL AT SAN LEANDRO

Working drawings have been approved and a CPA permit granted to build a 16-room, \$235,000 grammar school at San Leandro, California. Drag-on & Schmidts of Berkeley are the architects. Bids will soon be taken on the general contract, construction to be reinforced concrete and frame.

### ARCHITECTS MOVE

The architectural firm of Earl Heitschmidt & Charles O. Matcham, one of southern California's outstanding organization of architects, have moved into new offices at 449 South Beaudry, Los Angeles 13.

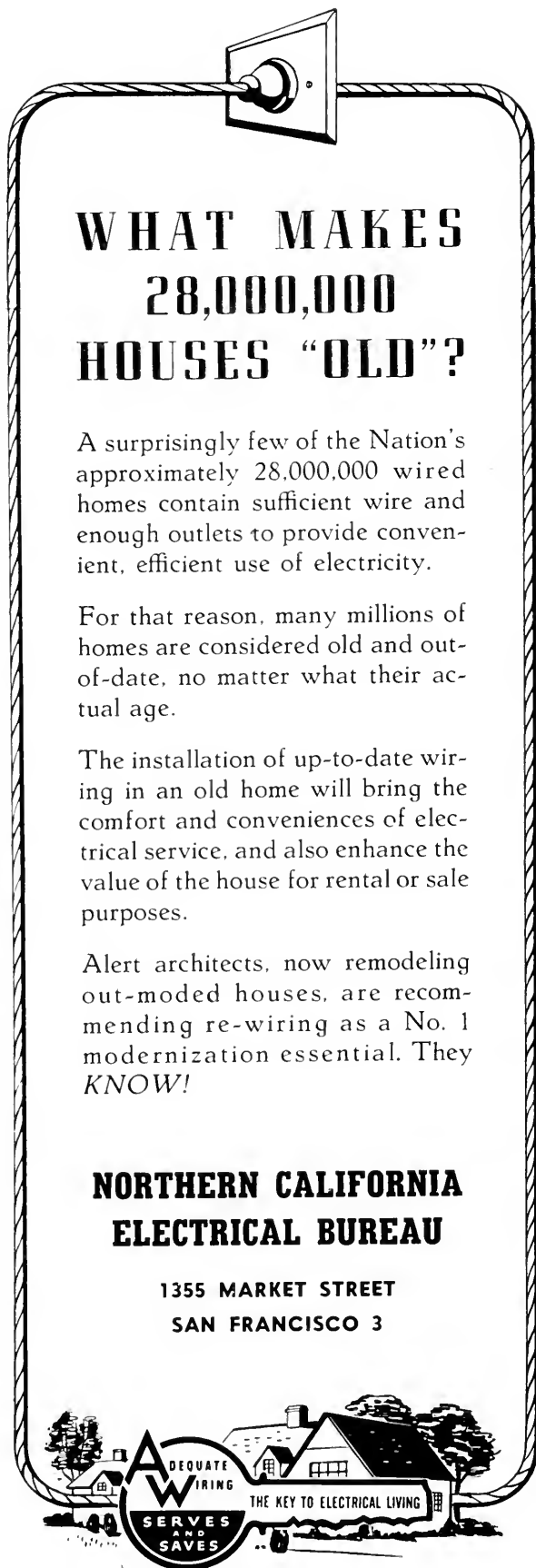

## WHAT MAKES 28,000,000 HOUSES "OLD"?

A surprisingly few of the Nation's approximately 28,000,000 wired homes contain sufficient wire and enough outlets to provide convenient, efficient use of electricity.

For that reason, many millions of homes are considered old and out-of-date, no matter what their actual age.

The installation of up-to-date wiring in an old home will bring the comfort and conveniences of electrical service, and also enhance the value of the house for rental or sale purposes.

Alert architects, now remodeling out-moded houses, are recommending re-wiring as a No. 1 modernization essential. They **KNOW!**

### NORTHERN CALIFORNIA ELECTRICAL BUREAU

1355 MARKET STREET  
SAN FRANCISCO 3



ADEQUATE WIRING  
SERVES AND SAVES  
THE KEY TO ELECTRICAL LIVING

**BAXCO**  
CHROMATED ZINC CHLORIDE

**ENZC**

**PRESSURE TREATED LUMBER**  
● **PROTECTS AGAINST DECAY  
AND TERMITE ATTACK**

*Specify it in your home  
Available through Lumber Dealers*

LOS ANGELES 601 W. 5th Street Phone Michigan 6294	SAN FRANCISCO 333 Montgomery Street Phone DOuglas 3883
---	--

***J. H. Baxter & Co.***

AGENTS FOR WEST COAST WOOD PRESERVING CO. SEATTLE, WASH.

"GOODS OF THE WOODS"  
**E. K. WOOD LUMBER CO.**

**W**

**LOS ANGELES**

*Branch Offices*

HOLLYWOOD	SIERRA MADRE	UPLAND
PASADENA	TEMPLE CITY	LA VERNE
LONG BEACH	WHITTIER	SAN PEDRO
RIVERSIDE	ONTARIO	INDIO

**OAKLAND**  
**SAN FRANCISCO**

# HEADLINE NEWS & VIEWS

By E. H. W.

The Tile Council of America says that more than 2,345,000 single family non-farm homes need new roofs or roofing repairs and some 2,037,000 must have heating equipment replaced or overhauled . . . 1,793,000 need floor and wall tile as a result of repairs needed in bathrooms.

A recent survey of a trading area population of 12,500,000 indicated that women shoppers place better interior display as the major factor in modern store construction; better lighting, redecoration, wider aisles, rapid change system, elevator and escalator, adequate comfort facilities, and attractive window displays are also desired by today's shoppers.

How often have you heard: "It's safe, it's durable, it's sound, it's an improvement over present conditions—and it's against the law." . . . The solution is, of course a new building code embodying new methods, new materials, and new scientific knowledge.

The number of common stock holders of U. S. Steel in the eleven western states increased during 1946 from 602,154 shares to 667,836 shares. Preferred stock holders also increased during the same period.

Los Angeles City Housing Authority has announced it will accept no further applications for housing until the present backlog of 16,000 pending applications has been reduced to 3,000. No new housing is in prospect.

Proposed reductions in Federal income taxes may never materialize as far as the average citizen is concerned . . . tax reduction is a politician metaphorically speaking from a hypothetical standpoint.

The Wyoming legislature's proposed motor vehicle act requiring California cars to carry red flags "three feet square, both fore and aft" is in retaliation for California Motor Vehicle Department regulations governing the motoring public . . . ill advised, arbitrary, rules imposed can easily nullify a tremendous amount of effort devoted to the building of good will . . . Lampton vs. Jeffery

If you want to undertake a major project . . . try getting some logical information from the Veterans' Administration.

## IN THE NEWS

### SURVEY OF SACRAMENTO

"Forecasting a City's Future," an economic study of the Sacramento, Calif. area, has been issued by the State Reconstruction and Reemployment Commission. It is based on a survey sponsored by the Postwar Planning Committee of the Sacramento Chamber of Commerce.

### NEW WALL SAFE

The new-type Meilink Wall Safe that is tested in a furnace at a temperature of 1700° is now available to home owners who want complete protection for their valuables. It is constructed of heavy steel plates electrically welded and Thermo-cel insulated walls.



A three-tumbler combination lock controls the two operating bolts in the front of the door and two interlocking bolts at the rear of the door. Easily installed, may be concealed behind a mirror or picture. Made by the MEILINK STEEL SAFE COMPANY, Toledo, Ohio.

### SANTA ROSA

A bond election for the building of a \$750,000 addition to the Santa Rosa (Calif.) High School will be held shortly. Additional work on the grammar school is also contemplated.

### ARCHITECT MOVES

Paul C. Overmire, architect, has moved his offices to the National Title Building, 126 West Third St., Los Angeles.

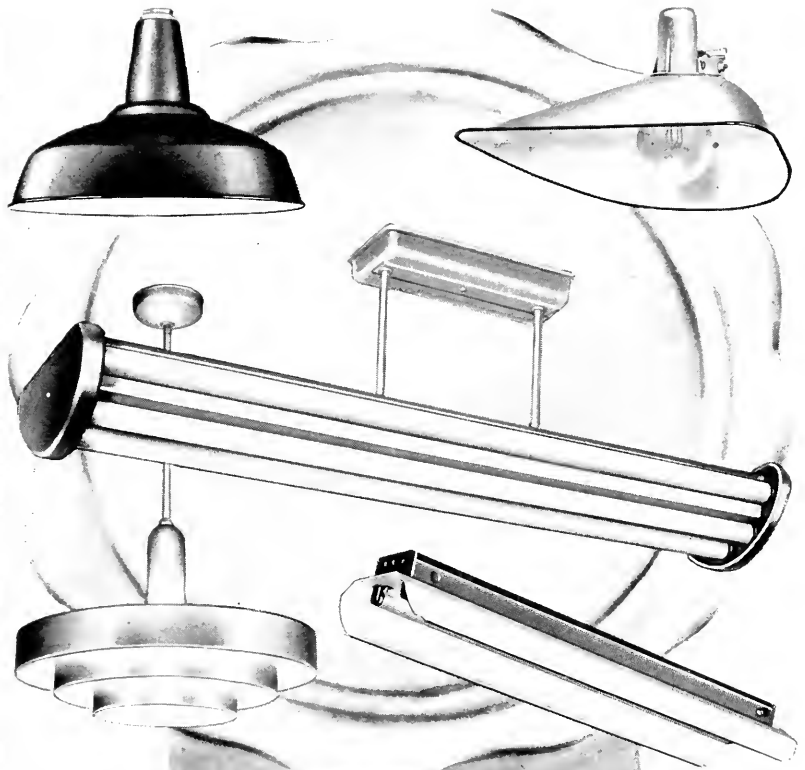

## Certified Quality

Certification is important when you buy lighting equipment. The SMOOT-HOLMAN, RLM and FLEUR-O-LIER approvals are your assurance of maximum lighting efficiency at the lowest maintenance cost.



**LOOK FOR THIS LABEL FOR THE FINEST IN INCANDESCENT AND FLUORESCENT LIGHTING**

Your Plans

for the Year 1947

Should Include

A Regular Schedule of  
Advertising

**Reaching the West's Building Trades**

In

*The Greatly Expanding Magazine*

**ARCHITECT & ENGINEER**

68 Post Street

San Francisco 4, Calif.

Phone EXbrook 7182

Publishers of

**ARCHITECTS (Daily) REPORTS**

## WITH THE ENGINEERS

(From Page 32)

ciency. It weighs approximately seven pounds per cubic foot and when mixed with Portland cement, produces a light concrete which is used extensively for insulating roof structures and in plaster for fire protection.

The use of pumice as a lightweight concrete aggregate was explained by Paul R. Splane and Phillip Lockwood. Pumice is a cellular volcanic lava occurring in Southern California desert regions. When used as an aggregate in concrete it produces a lightweight product of good structural characteristics, adaptable to masonry units and for insulation and fireproofing purposes.

### PUGET SOUND ENGINEERING COUNCIL

The poll of member societies on changing the name of the council from the "Puget Sound Council of Engineering and Technical Societies" to its present name of "Puget Sound Engineering Council" showed a practically unanimous disposition toward the new name. It was therefore adopted and an emblem approved containing the name.

A nominating committee was named at a recent meeting to consider officers for 1947. Alfred Miller, Fairman Lee and Charlie May were named to the committee with Miller as chairman.

Six engineers received licenses to practice in the State of Washington recently. They are: L. M. Baugh and G. H. Walker, of Seattle; G. A. Drewett, E. A. Marshall, and W. K. Wilson, of Portland, Ore., and J. M. Worthen of Tacoma.

### ILLUMINATING ENGINEERS HEAR SPEAKER

The Southern California Section of the Illuminating Engineering Society met recently in Los Angeles at which time R. E. Madigan, manager of airport lighting sales of the Line Material Company, spoke on "Aviation Lighting Development."

### "SMOG" DISCUSSED BY CIVIL ENGINEERS

The problem of "Smog" in Los Angeles was taken up in some detail at a recent meeting of the Los Angeles Section of the American Society of Civil Engineers, the principal speaker of the evening being William M. Jeffers, vice-president of the board of the Union Pacific Railroad.

Others who spoke on the same topic included: Harold W. Kennedy, Los Angeles county counsel; Andrew O. Porter, deputy Los Angeles county counsel; Roland W. Reynolds, engineer-investigator of the Office of Air Pollution Control, Los An-

geles county; and Howard Barnes, member, Smoke and Fumes Committee, Los Angeles Chamber of Commerce.

The Junior Forum met earlier in the evening, at which technical papers were presented.

### WESTERN DIVISION ORGANIZES

Members of the American Council of Commercial Laboratories from the Western states met in San Francisco recently and organized themselves into a group to be known as the Western Division of the ACCL. The division will include members in Alaska and the Hawaiian Islands.

Dr. Roger W. Truesdail, Truesdail Laboratories,

## STRUCTURAL STEEL

For Class A Buildings,  
Bridges, etc.

### JUDSON PACIFIC - MURPHY CORP.

1200 SEVENTEENTH STREET  
SAN FRANCISCO

Plants: San Francisco - Oakland

# SISALKRAFT

REG. U. S. PAT. OFF.

*"More than a building paper"*

### THE SISALKRAFT CO.

205 West Wacker Drive  
Chicago, Ill.

55 New Montgomery Street  
San Francisco, Calif.

## FORDERER CORNICE WORKS

Manufacturers of

Hollow Metal Products • Interior Metal Trim  
Elevator Fronts and Cabs  
Metal Plaster Accessories • Sanitary Metal Base  
Flat and Roll Metal Screens  
Metal Cabinets • Commercial Refrigerators

269 POTRERO AVE.

SAN FRANCISCO, CALIF.

HEMLOCK 4100

Inc., Los Angeles, was elected president; vice-president, Herbert D. Imrie, Abbot A. Hanks, Inc., San Francisco; secretary-treasurer, E. Ord Slater, Smith-Emery Co., Los Angeles.

Since its inception in 1937, the Council has expanded until in 1946 it represents 32 independent laboratories.

#### **ELECTRIC CLUB HEARS MULLENDORE**

W. C. Mullendore, president of Southern California Edison Company, was the principal speaker at a recent luncheon meeting of the Electric Club at the Biltmore Hotel, Los Angeles. Samuel B. Morris, general manager and chief engineer, Los Angeles Dept. of Water and Power, was chairman for the occasion.

#### **SPEAKS BEFORE CIVIL ENGINEERS**

Joseph S. Pecker, Los Angeles consulting engineer, addressed a recent dinner meeting of the Southern California section of the American Society of Mechanical Engineers on the subject: "Functional Design for Customer Appeal."

#### **POWER ENGINEERS TO CONVENE**

More than 2500 engineers from all parts of the world are expected to attend the Midwest Power Conference at Chicago, April 1 and 2.

All phases of power, its production, distribution

and current problems will be studied, including hydro power, small power plants, diesel power, power cables, central station practices, and electronics as related to power. Seventeen technical sessions have been arranged in all.

#### **LOS ANGELES STRUCTURAL ENGINEERS MEET**

The Structural Engineers Association of Southern California met recently at the Hotel Clark in Los Angeles and heard William T. Wright relate his experiences in the Southwest Pacific. Illustrative films were also shown.

C. M. Herd also spoke and told of the building of the Woinde Base in the Biak area.

#### **TALKS ON STEAM DEVELOPMENTS**

A talk on "Modern Steam Turbine Developments" by John R. Carlson, central station steam engineer, Westinghouse Electric Company, featured a recent meeting of the American Society of Mechanical Engineers, Southern California section, held at the Edison Auditorium in Los Angeles.

#### **CENTRAL VALLEY PROJECT HALF COMPLETED**

California's Central Valley Project, including the key units—Friant and Shasta dams—is more than half completed.

By June 30, end of the 1946-47 fiscal year, the Bureau of Reclamation will have spent about \$200 million on the project, with \$185 million still to be expended.

Sums to be spent and the units for which they will be expended are:

**Shasta Dam**, \$4,138,000; **Shasta Power House**, \$2,178,000; **Keswick Dam**, \$2 million; **Keswick Power Plant**, \$1,547,000; **Friant Dam**, \$492,000; **Friant-Kern Canal**, \$20,497,000; **Delta-Mendota Canal**, \$66 million; **Delta Cross Channel**, \$10,500,000; **Madera Canal**, \$64,000; **Contra Costa Canal**, \$902,000; **Contra Costa Laterals**, \$2,600,000; **Transmission Lines**, \$25,134,000; **Power Switchyards**, \$10,136,000; **Steam Plant**, \$26 million.

#### **EAST BAKERSFIELD HIGH ADDITION**

The Kern County Union school district is taking bids on the general contract for an addition to the high school at East Bakersfield, Calif., to cost \$150,000. The architect is Charles H. Biggar of Bakersfield.

Plans call for a 2-story reinforced concrete building with 2 biology laboratories, a physics laboratory, a science lecture room and a typing room.

#### **VETERANS AT U. C.**

Disabled veterans on the eight campuses of the University of California now total 870.

# **A HANDY SERVICE**

Invaluable to those desirous of taking advantage of Postwar opportunities in the building-construction, and engineering field.

Consists of DAILY REPORTS giving name, location, architect, proposed cost and other valuable information about projects in Northern California.

Total cost \$10 per month

DON'T DELAY • SUBSCRIBE TODAY

# **ARCHITECT'S REPORTS**

Published Daily By

**ARCHITECT and ENGINEER, Inc.**

68 Post Street, San Francisco

EXbrook 7182

# ESTIMATOR'S GUIDE

## BUILDING AND CONSTRUCTION MATERIALS

PRICES GIVEN ARE FIGURING PRICES AND ARE MADE UP FROM AVERAGE QUOTATIONS FURNISHED BY MATERIAL HOUSES TO SAN FRANCISCO CONTRACTORS. 2 1/2% SALES TAX ON ALL MATERIALS BUT NOT LABOR

All prices and wages quoted are for San Francisco and the Bay District. There may be slight fluctuation of prices in the interior and southern part of the state. Freight cartage, at least, must be added in figuring country work.

**PAVING—Performance—**\$10 per \$1000 of contract. Labor and materials, \$10 per \$1000 of contract.

**BRICKWORK—**

Common Brick—Per IM laid—\$80.00 to \$100.00 (according to class of work).

Face Brick—Per IM laid—\$150 to \$200 (according to class of work).

Brick Steps—\$2.30 per lin. ft.

Brick Veneer on Frame Bldg.—Approx. \$1.50 per sq. ft.

Common Brick—\$26.00 per M, truckload lots, f.o.b. job.

Face Brick—\$60 to \$100 per M, truckload lots, delivered.

Cartage—Approx. \$5.00 per M.

**CEILING PAPER—**

ply per 1000 ft. roll..... \$5.30  
 ply per 1000 ft. roll..... 7.80  
 ply per 1000 ft. roll..... 9.70  
 Brownskin, Standard, 500 ft. roll..... 7.00

**CEILING HARDWARE—**

ash cord com. No. 7..... \$2.50 per 100 ft.  
 ash cord com. No. 8..... 2.75 per 100 ft.  
 ash cord spot No. 7..... 3.50 per 100 ft.  
 ash cord spot No. 8..... 3.75 per 100 ft.  
 ash weights, cast iron, \$50.00 ton.  
 Nails, \$3.42 base.  
 ash weights, \$45.00 per ton.

**CONCRETE AGGREGATES—**

The following prices net to Contractors unless otherwise shown. Carload lots only.

	Bunker per ton	Del'd per ton
Gravel, all sizes .....	\$2.44	\$2.15
Top Sand .....	2.38	3.13
Concrete Mix .....	2.38	3.06
Crushed Rock, 1/4" to 3/4".....	2.38	2.94

	Bunker per ton	Del'd per ton
Crushed Rock, 3/4" to 1 1/2".....	\$2.38	\$3.13
Roofing Gravel .....	2.81	3.50
River Sand .....	2.50	3.06

**Sand—**

Lapis (Nos. 2 & 4) .....	3.56	3.94
Olympia (Nos. 1 & 2) .....	3.56	3.88

**Cement—**

Common (all brands, paper sacks), carload lots, \$3.02 per bbl. f.o.b. car; delivered \$3.40. Cash discount on carload lots, 10c a bbl., 10th Prox., less than carload lots \$4.00 per bbl. f.o.b. warehouse or delivered. Cash discount 2% on L.C.L.

Atlas White } 1 to 100 sacks, \$3.13 sack  
 Calaveras White } warehouse or del.; \$9.56  
 Medusa White } bbl. carload lots.

**DAMP-PROOFING and Waterproofing—**

Two-coat work, \$5.00 per square.  
 Membrane waterproofing—4 layers of saturated felt, \$9.00 per square.  
 Hot coating work, \$3.00 per square.  
 Medusa Waterproofing, \$3.50 per lb. San Francisco Warehouse.  
 Tricocel waterproofing.  
 (See representative.)

**ELECTRIC WIRING—**\$15 to \$20 per outlet for conduit work (including switches).

Knob and tube average \$6.00 per outlet. (Available only for priority work.)

**ELEVATORS—**

Prices vary according to capacity, speed and type. Consult elevator companies. Average cost of installing a slow speed automatic passenger elevator in small four story apartment building, including entrance doors, about \$8000.00.

**EXCAVATION—**

Sand, \$1.00; clay or shale, \$1.50 per yard. Trucks, \$30 to \$45 per day. Above figures are an average without water. Steam shovel work in large quantities, less; hard material, such as rock, will run considerably more.

**FIRE ESCAPES—**

Ten-foot galvanized iron balcony, with stairs. \$250 installed on new buildings; \$300 on old buildings.

**FLOORS—**

Composition Floors, such as Magnesite, 50c per square foot.

Linoflor—2 gages—\$3.00 per sq. yd.

Mastipave—\$1.50 per sq. yd.

Battleship Linoleum—available to Army and Navy only—1/8"—\$3.50 sq. yd. 3/16"—\$3.50 sq. yd.

Terazzo Floors—\$1.50 per sq. ft.

Terazzo Steps—\$2.50 per lin. ft.

Mastic Wear Coat—according to type—20c to 35c.

**Hardwood Flooring—**

Standard Mill grades not available.  
 Victory Oak—T & G  
 3/8" x 2 1/4"..... \$252.00 per M. plus Cartage  
 1/2" x 2"..... \$210.00  
 1/2" x 1 1/2"..... 200.00

Prefinished Standard & Better Oak Flooring  
 3/8" x 3 1/4"..... \$265.00 per M. plus Cartage  
 1/2" x 2 1/2"..... 237.00 per M. plus Cartage

Maple Flooring  
 3/8" T & G Clear \$330.00 per M. plus Ctg.  
 2nd 305.00 per M. plus Ctg.  
 3rd 255.00 per M. plus Ctg.  
 Floor Layers' Wage, \$1.87 1/2 per hr. (Legal as of Jan. 21, 1946. Given us by Inlaid Floor Co.)

**GLASS—**

Single Strength Window Glass..... \$4.00 per sq. ft.  
 Double Strength Window Glass..... .60 per sq. ft.  
 Plate Glass, under 75 sq. ft..... 1.25 per sq. ft.  
 Polished Wire Plate Glass..... 2.10 per sq. ft.  
 Rgh. Wire Glass..... .60 per sq. ft.  
 Obscure Glass..... .40 per sq. ft.  
 Glazing of above is additional.  
 Glass Blocks..... \$2.75 per sq. ft. set in place

**HEATING—**

Average, \$2.50 to \$3.00 per sq. ft. of radiation, according to conditions.  
 Warm air (gravity) average \$64 per register.  
 Forced air average \$91 per register.

**INSULATION AND WALLBOARD—**

R. W. Insulation—Full thickness 3 1/2" .....	\$79.00 per M sq. ft.
C. H. Insulation—Full thickness (3 1/2") .....	\$95.50 per M sq. ft.
Aluminum Insulation—Foil-mounted with Ectex Faces .....	\$33.50 per M sq. ft.
T. Wallboard—4'x8' panel .....	\$9.00 per panel
Wallboard—2" thickness .....	\$49.50 per M sq. ft.
Finished Fork .....	\$69.00 per M sq. ft.
Ceiling Tileboard .....	\$69.00 per M sq. ft.

**IRON**—Cost of ornamental iron, cast iron, etc. depends on designs.

**LUMBER—**

No. 1 Common .....	\$90.00 per M
No. 2 Common .....	\$88.00 per M
Select O. P. Common .....	\$94.00 per M

**Flooring—**

Per M Delvd.	
V.G.-D.F. B & Btr. 1 x 4 T & G Flooring	\$170.00
"C" and better—all .....	170.00
"D" and better—all .....	170.00
Rwd. Rustic—"A" grade, medium dry .....	150.00
8 to 24 ft. .....	150.00
"B" grade, medium dry .....	150.00

**Plywood** .....

15c to 18c per ft.	
Plyscord .....	9/2c per ft.
Plywall .....	9c per ft.
Plyform .....	15c per ft.

**Shingles (Rwd. not available)—**

Red Cedar No. 1—\$13.00 per square; No. 2, \$10.50; No. 3, \$9.00.  
Average cost to lay shingles, \$6.00 per square.  
Cedar Shakes—Tapered: 1/2" to 3/4" x 25"—\$17.00 per square.  
Resawn: 3/4" to 1 1/4" x 25"—\$22.00 per square  
Average cost to lay shakes,—8.00 per square

**MILLWORK—Standard.**

D. F. \$140 per 1000. R. W. Rustic \$150 per 1000 (delivered).  
Double hung box window frames, average with trim. \$10 and up, each.  
Complete door unit, \$14 to \$20.  
Screen doors, \$6.00 to \$8.00 each.  
Patent screen windows, 50c a sq. ft.  
Cases for kitchen pantries seven ft. high, per lineal ft., \$12.00 each.  
Dining room cases, \$12.00 per lineal foot.  
Rough and finish about \$1.00 per sq. ft.  
Labor—Rough carpentry, warehouse heavy framing (average), \$60.00 per M.  
For smaller work average, \$60.00 to \$75.00 per 1000.

**MARBLE—(See Dealers)**

**PAINTING—**

Two-coat work .....	per yard 60c
Three-coat work .....	per yard 80c
Cold water painting .....	per yard 25c
Whitewashing .....	per yard 15c

**PAINTS—**

Two-coat work .....	60c per sq. yd.
Three-coat work .....	80c per sq. yd.
Cold water painting .....	25c per sq. yd.
Whitewashing .....	15c per sq. yd.
Turpentine .....	\$1.85 per gal. in 5-gal. cont.
Raw Linseed Oil .....	\$3.19 per gal. in 5-gal. cont.

Boiled Linseed Oil .....	\$2.50 per gal. in drums
Boiled Linseed Oil—\$2.90 per gal. in 5-gal. containers.	
Replacement Oil—\$2.56 per gal. in drums, \$2.56 per gal. in 5-gal. containers.	
Use Replacement Oil .....	\$2.69 per gal. in 1 gal. cont.
A deposit of \$7.50 required on all drums.	

**PATENT CHIMNEYS—**

6-inch .....	\$2.00 lineal foot
8-inch .....	2.50 lineal foot
10-inch .....	3.50 lineal foot
12-inch .....	4.50 lineal foot

**PLASTER—**

Neat wall, per ton delivered in S. F. in paper bags, \$17.60.

**PLASTERING (Interior)—**

	Yard
3 Coats, metal lath and plaster .....	\$3.00
Keene cement on metal lath .....	3.50
Ceilings with 3/4 hot roll channels metal lath (lathed only) .....	3.00
Ceilings with 3/4 hot roll channels metal lath plastered .....	4.50
Single partition 3/4 channel lath 1 side (lath only) .....	3.00
Single partition 3/4 channel lath 2 inches thick plastered .....	8.00
4-inch double partition 3/4 channel lath 2 sides (lath only) .....	5.75
4-inch double partition 3/4 channel lath 2 sides plastered .....	8.75
Thermax single partition; 1" channels; 2 1/4" overall partition width. Plastered both sides .....	7.50
Thermax double partition; 1" channels; 4 3/4" overall partition width. Plastered both sides .....	11.00
3 Coats over 1" Thermax nailed to one side wood studs or joists .....	4.50
3 Coats over 1" Thermax suspended to one side wood studs with spring sound isolation clip .....	5.00
Note—Channel lath controlled by limitation orders.	

**PLASTERING (Exterior)—**

	Yard
2 coats cement finish, brick or concrete wall .....	\$2.50
3 coats cement finish, No. 18 gauge wire mesh .....	3.50
Lime—\$4.00 per bbl. at yard.	
Processed LLime—\$4.15 per bbl. at yard.	
Rock or Grip Lath—3/8"—30c per sq. yd.	
1 1/8"—29c per sq. yd.	
Composition Stucco—\$4.00 sq. yard (applied).	

**PLUMBING—**

From \$150.00 per fixture up, according to grade, quality and runs.

**ROOFING—**

"Standard" tar and gravel, 4 ply—\$11.00 per sq. for 30 sqs. or over.  
Less than 30 sqs. \$14.00 per sq.  
Tile \$40.00 to \$50.00 per square.  
Redwood Shingles, \$15.00 per square in place.  
5/2 #1-16" Cedar Shingles, 4 1/2" Exposure .....

5/8 x 16"—#1 Cedar Shingles, 5" Exposure .....	\$17.00
4/2 #1-24" Royal Shingles, 7 1/2" Exposure .....	\$18.25
Re-coat with Gravel \$5.50 per sq.	
Asbestos Shingles \$30 to \$60 per sq.	
1/2 x 25" Resawn Cedar Shakes, 10" Exposure .....	
3/4 x 25" Resawn Cedar Shakes, 10" Exposure .....	
1 x 25" Resawn Cedar Shakes, 10" Exposure .....	
Above prices are for shakes in place	

**SHEET METAL—**

Windows—Metal, \$2.50 a sq. ft.  
Fire doors (average), including hardware \$2.80 per sq. ft.

**SKYLIGHTS—(not glazed)**

Copper, \$1.25 sq. ft. (flat).  
Galvanized iron, 65c sq. ft. (flat).  
Vented hip skylights 90c sq. ft.

**STEEL—STRUCTURAL—**

Base, delivered, \$3.06 per 100, plus extras; or \$300.00 to \$400.00 in place. Light truss work higher.

**STEEL REINFORCING—**

\$200.00 ton, set.

**STORE FRONTS (None available).**

**TILE—**

Ceramic Tile Floors—\$1.50 per sq. ft.  
Cove Base—\$1.25 per lin. ft.  
Glazed Tile Wainscot—\$1.50 per sq. ft.  
Asphalt Tile Floor 1/8" x 1 1/8"—\$ .40 per sq. ft. Light shades slightly higher.  
Cork Tile—\$1.00 per sq. ft.  
Mosaic Floors—See dealers.  
Lino-Tile—\$1.00 per sq. ft.

**Wall Tile—**

Glazed Terra Cotta Wall Units (single laid in place—approximate prices:

2 x 6 x 12 .....	\$1.25
4 x 6 x 12 .....	1.50
2 x 8 x 16 .....	1.45
4 x 8 x 16 .....	1.75

**VENETIAN BLINDS—**

85c per square foot and up. Insta extra.

**WINDOWS—STEEL—**

50c per square foot, \$5 for ventilator

**ARCHITECT AND ENGINEER**



# IN THE NEWS

## CHEMICAL PLANT CONSTRUCTION

A \$4 million chemical processing plant is being constructed by the American Potash & Chemical Company at Searles Lake, Calif., for the American Potash & Chemical Corporation, Ltd., general contractor.

## STORE AND OFFICE BUILDING

A \$125,000 store and office building will soon be constructed at 14th and Webster Sts., Oakland, for J. B. Anthony, architect.

**OPENS OFFICE:** H. L. Marchand has opened a private structural engineering office in the Balboa Bldg., 593 Market St., San Francisco.

## NEW FORD-V-NEER FIBERGLASS SIDING

This new FORD-V-NEER panel siding using Fiberglass as the structural base material marks a step forward in the field of asphalt sidings.

The Fiberglass base is completely inorganic; it cannot rot or decay, absorb moisture or shrink, and is completely weatherproof. It is also

proof against termites and is light in weight.

Furnished in panels 5/8" thick, 24" x 36" in size, shiplapped on four edges, in either brick or stone pattern and a wide variety of colors. It is manufactured by the FORD ROOFING PRODUCTS COMPANY, 111 West Washington St., Chicago 2, Ill.

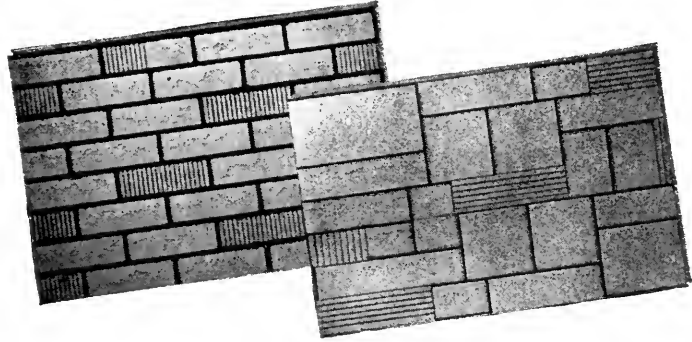

## BUILDING TRADES WAGE (JOB SITES) NORTHERN AND CENTRAL CALIFORNIA

ATTENTION: The following are the PREVAILING hourly rates of compensation as determined by the Wage Adjustment Board, or which have been determined by the United States Department of Labor—Revised to July 1, 1946. Wage scales shown are those being paid and in effect mostly by agreement between employees and their union.

CRAFT	San Francisco	Alameda and Contra Costa	Marin	Vallejo	San Mateo	San Jose	Stockton	Sacramento	Fresno
PLASTERERS	1.75	1.75	1.75	1.75	1.75	1.75	1.75	1.75	1.75
ROOFERS	2.05	2.05	2.05	2.05	2.05	2.05	2.05	2.05	2.00
ROOFERS, HODCARRIERS	1.57 1/2	1.57 1/2	1.57 1/2	1.57 1/2	1.57 1/2	1.57 1/2	1.47 1/2	1.15	1.25
CARPENTERS	1.75	1.75	1.75	1.75	1.75	1.62 1/2	1.50	1.50	1.50
INTERIORS FINISHERS	1.75	1.75	1.75	1.75	1.75	1.75	1.75	1.75	1.75
ELECTRICIANS	1.87 1/2	1.87 1/2	1.87 1/2	1.70	1.87 1/2	1.87 1/2	1.75	1.82 1/2	1.75
MECHANICS: MATERIAL HOIST	1.60	1.60	1.60	1.60	1.60	1.60	1.60	1.60	1.60
PILE DRIVER	2.00	2.00	2.00	2.00	2.00	2.00	2.00	2.00	2.00
STRUCTURAL STEEL	2.00	2.00	2.00	2.00	2.00	2.00	2.00	2.00	2.00
WELDERS	1.58 1/2	1.58 1/2	1.58 1/2	1.58 1/2	1.58 1/2	1.21	1.40	1.37 1/2	1.37 1/2
IRONWORKERS: ORNAMENTAL	1.85	1.85	1.85	1.85	1.85	1.85	1.85	1.85	1.85
REINFORCING	1.75	1.75	1.75	1.75	1.75	1.75	1.75	1.75	1.75
STRUCTURAL	2.00	2.00	2.00	2.00	2.00	2.00	2.00	2.00	2.00
LABORERS: BUILDING & CONCRETE	1.25	1.25	1.15	1.15	1.15	1.15	1.25	1.25	1.15
PAINTERS	1.90	1.90	1.60	1.87 1/2	1.75	2.00	1.87 1/2	1.60	1.87 1/2
PAINTERS: WALL SETTERS	1.75	1.75	1.75	1.75	1.75	1.75	1.75	1.75	1.75
PAINTERS: SAIC & TERRAZZO	1.75	1.75	1.75	1.75	1.75	1.75	1.60	1.16	1.12 1/2
PAINTERS: INTERIORS	1.75	1.75	1.75	1.64	1.75	1.75	1.60	1.60	1.50
PAINTERS: EXTERIORS	1.86	1.86	1.86	1.86	1.86	1.86	1.86	1.86	1.86
PAINTERS: MASTERERS	2.00	2.00	1.75	2.00	2.05	2.00	2.00	1.87 1/2	1.87 1/2
PAINTERS: MASTERERS' HODCARRIERS	1.75	1.75	1.75	1.75	1.75	1.75	1.65	1.65	1.40
PAINTERS: SIGNERS	1.87 1/2	1.87 1/2	1.87 1/2	1.87 1/2	1.87 1/2	1.87 1/2	1.87 1/2	1.87 1/2	1.87 1/2
PAINTERS: SIGNERS	1.50	1.62 1/2	1.50	1.62 1/2	1.25	1.37 1/2	1.50	1.50	1.50
PAINTERS: SHEET METAL WORKERS	1.75	1.75	1.75	1.75	1.75	1.75	1.75	1.75	1.75
PAINTERS: SINKLER FITTERS	1.58	1.58	1.58	1.58	1.58	1.58	1.58	1.58	1.58
PAINTERS: PLUMBERS	1.87 1/2	1.87 1/2	1.87 1/2	1.87 1/2	1.87 1/2	1.87 1/2	1.87 1/2	1.87 1/2	1.87 1/2
PAINTERS: PIPE SETTERS (MASON'S)	2.05	2.05	2.05	2.05	2.05	2.05	1.75	2.05	2.00
PAINTERS: PIPE SETTERS	1.80	1.75	1.75	1.75	1.75	1.75	1.37 1/2	1.37 1/2	1.37 1/2

Prepared and compiled by

CENTRAL CALIFORNIA CHAPTER, ASSOCIATED GENERAL CONTRACTORS OF AMERICA

with the assistance and cooperation of secretaries of General Contractors Associations and Builders Exchanges of Northern California.

# CLASSIFIED ADVERTISING

RATE: 10c PER WORD . . . CASH WITH ORDER

MINIMUM \$2.50

**ARCHITECT'S REPORTS**—A valuable advance news service giving building and construction information daily on projects in Northern California. Name, location, architect, proposed cost, etc., on individual slips. Ideal for securing new business leads. Hundreds of items, total monthly cost only \$10. Don't delay, subscribe today. ARCHITECT ENGINEER, Room 618, 68 Post Street, San Francisco, California. Phone DOuglas 11.

**PHOTOGRAPHY**—Keep a pictorial record of your building, or construction project. Pictures are of tremendous value to contractors, builders, engineers, architects. For Industrial-Publicity-Aerial photography, see FRED MAE, Room 721-22 Hearst Bldg., San Francisco 3, California.

**POWER HOIST**, double spool, Briggs & Stratton engine, reduction gear, 24 to 1, two friction clutches, two spline clutches, two

brakes. Capacity 1500 lbs., 100 feet per minute. Complete, compact unit, 4 feet square, weighs 500 lbs. Only \$250.00 plus sales tax f.o.b. Stockton, Calif. PHILLIPS FORWARDING CO., 109 So. Van Buren St., Stockton, Calif., Ph. 34654.

**ENGRAVING**—Good engravings are essential to a satisfactory job of printing reproduction. For the best, see Poor Richard Photo Engraving Co., 324 Commercial St., San Francisco.

# IN THE NEWS

## VEGETABLE OIL PLANT

A CPA permit has been granted for the construction of a \$300,000 vegetable oil plant in San Francisco by the Valianos Company. H. C. Baumann of San Francisco is the architect and James M. Smith the structural engineer.

The project will consist of four buildings of reinforced concrete and corrugated metal construction with a structural steel frame.

## HOGAN LUMBER CO.

*Wholesale and Retail*

### LUMBER

---

**MILL WORK • SASH & DOORS**

---

*Office, Mill, Yard and Docks*

**SECOND AND ALICE STREETS • OAKLAND, CALIF.**

*Telephone GLencourt 6861*

## CLINTON CONSTRUCTION CO.

OF CALIFORNIA

### *General Contractors*

**923 FOLSOM STREET • SAN FRANCISCO**

SUtter 3440

## SANTA MARIA INN

### SANTA MARIA, CALIFORNIA

**FRANK J. McCOY, General Manager**

**FERNAND E. PIMENTEL, Manager**



American  
or  
European  
Plan  
•  
Old  
English  
Tap  
Room

On the Coast Highway between San Francisco and Los Angeles

## THE WEST MOVES FORWARD

F. B. DeLong, Vice-president in charge of sales, Columbia Steel Company, stated in a recent interview: "Western industry is only just beginning to come into its own . . . our population is increasing every month . . . people are moving westward, and people make markets . . . and where you find markets you find industry moving in to serve those markets. The Pacific Coast is the great undeveloped area of our nation . . . we have everything industry needs here, and the eyes of the whole nation are looking this way . . ."

## NEW POLICE STATION

Work has been started on the drawings for the new \$450,000 police station to be constructed in Reno, Nevada, with Blanchard Maher & Lockard of Reno as the architects.

It will be a three story building of reinforced concrete.

## NEW SAN JOSE STORE

Roos Brothers, dry goods and apparel firm, have received a CPA permit to build a \$350,000 department store in San Jose, Albert R. Williams, San Francisco, architect.

The store will be 2-story and basement structure of reinforced concrete and structural steel frame, with a marble exterior to the second floor. Provision will be made for three additional stories. Dinwiddie Construction Company of San Francisco is the general contractor.

## SEWAGE DISPOSAL PLANT

Mill Valley, Calif., is taking bids on a new sewage disposal and pumping plant expected to cost about \$166,000. Construction will be of reinforced concrete, John S. Bates of Berkeley, engineer.

## HOUSING PROJECT

A \$4 million cooperative housing project consisting of 400 residences is contemplated by the Peninsula Housing Association of Palo Alto, Calif. Architects Funk & Stein of San Francisco have been selected to draw the plans.

The development will be located south of the Stanford University golf course.

## NEW BASE HOSPITAL

Donald R. Warren Co., of San Francisco have been chosen structural engineers for the \$3 million, 150-bed base hospital building to be constructed at the Fairfield-Suisun Army Air Base. It will be a four story and basement, reinforced concrete building. Stolte Inc. and Morrison & Knudson are the general contractors.

## BOOK REVIEWS PAMPHLETS AND CATALOGUES

"CITY & REGIONAL PLANNING PAPERS." By Alfred Bettman, Harvard University Press, publishers. \$4.50.

This volume comprises a selection of twenty-four of Alfred Bettman's most significant planning papers and studies on city planning and urban redevelopment.

"LIGHTING TO A T." Cutter Light Manufacturing Co., 2026 N. 22nd Street, Philadelphia 21, Pa.

A detailed brochure about cold cathode lighting and how to plan it; comprehensive in scope, contains engineering data and answers questions for architects, designers, and electrical engineers. Copies upon request of publisher.

**SURVEYING: THEORY AND PRACTICE**, by J. C. Tracy. John Wiley & Sons, Inc., Publishers, 440 Fourth Avenue, New York 16, N. Y. Price \$7.50.

Book is by J. C. Tracy, Professor of Civil Engineering Emeritus, Yale University, who also wrote "Plane Surveying," which since its publication forty years ago has been used by more than one hundred thousand engineers. The new book includes all that is best in the old one, plus five hundred pages of new subject matter.

Most comprehensive, the book includes many condensations of outstanding technical papers and is divided into: Part I—Field Work; Part II—Office work; Part III—Surveying Instruments; and Part IV—Standard Surveys.

**PANEL HEATING AND COOLING ANALYSIS**, by B. F. Raber and F. W. Hutchinson. John Wiley & Sons, Inc., Publishers, 440 Fourth Ave., New York 16. Price \$3.50.

Contains a theoretical and practical discussion of the general principles, design features, types of equipment, and special uses of radiant surfaces. Non-technical, descriptive sections are followed by rigorous analytical chapters, including theoretical and simplified treatments of shape factor evaluations, radiant interchanges, and technical design.

### FROZEN FOOD WAREHOUSE

A frozen food warehouse to cost \$120,000 is planned by Food Facilities, Inc., of Patterson, Calif., the general contractor to be Fredrich Haase & Associates of Patterson. It will be of frame and brick veneer construction.

## VERMONT MARBLE COMPANY

Producers and Finishers  
of  
Domestic and Imported Marbles

525 MARKET STREET, SAN FRANCISCO  
Phone SÜtter 6747

727 W. 7th STREET, LOS ANGELES  
Phone TRinity 3459



The Most Complete Line of  
**STEELS and BUILDING MATERIALS**  
Made by a Single Producer



See Sweet's Catalog File or write us for  
full information.

**REPUBLIC STEEL CORPORATION**  
GENERAL OFFICES: CLEVELAND, OHIO

DENVER, COLORADO . . . . . CONTINENTAL OIL BUILDING  
LOS ANGELES, CALIFORNIA . . . . . EDISON BUILDING  
SALT LAKE CITY, UTAH . . . . . WALKER BANK BUILDING  
SAN FRANCISCO, CALIFORNIA . . . . . RIALTO BUILDING  
SEATTLE, WASH. . . . . WHITE-HENRY-STUART BUILDING

## PACIFIC MANUFACTURING CO.

HIGH CLASS INTERIOR FINISH  
QUALITY MILLWORK

142 SANSOME ST., SAN FRANCISCO  
GARfield 7755

6820 MCKINLEY AVE., LOS ANGELES  
THornwall 4196

BUILDERS EXCHANGE, OAKLAND

## "AMERICAN - MARSH"

CONDENSATION UNIT

Pumping  
Machinery  
for  
Every  
Purpose

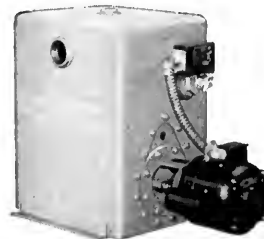

For Service  
Call  
DOuglas  
6794  
or  
MUtual8322

**SIMONDS MACHINERY CO.**  
SAN FRANCISCO 816 FOLSOM  
LOS ANGELES 455 EAST 4TH

## IN THE NEWS

### SAN DIEGO CHURCH

Architect Walter C. See of San Diego is taking general contract bids for construction of a new church building for the Linda Vista Methodist Church, San Diego. Estimated cost, \$45,000.

### ARMY TRANSFERS BUILDINGS

Colonel Joseph C. Killian, acting district engineer of the Los Angeles District, Corps of Engineers, War Dept., has transferred to the Federal Works Agency, Bureau of Community Facilities, San Francisco, 207 buildings with their installed improvements and equipment, all of which are located at the Santa Ana Army Air Base, according to a recent release from his office.

The buildings consist chiefly of barracks, supply and recreation buildings, mess halls, and hospital and administration buildings. Their total value is placed at \$11,083,000.

### STANDARD SANITARY AT TORRANCE

Waale Camplan Company & Smith, Inc., of Los Angeles, have been awarded the general contract for construction of a factory building at Torrance, Calif., for the American Radiator & Standard Sanitary Company at an expected cost of \$1,750,000.

The structural steel work on the building has been awarded to the

Bethlehem Pacific Steel Corp, Vernon Calif.

Plans for the building have been prepared by architects Prack & Prack of Pittsburgh, Pa. Taylor-Barnes of Los Angeles are the structural engineers.

### NEW STREAMMASTER BOILER DEMONSTRATED

Mr. Ed Grant, President of Streammaster Boilers, shown inspecting 5 h. p. Model "A" steam boiler just off production line. New from top to bottom, these boilers are built upon recognized steam combustion engineering principles.



The Model "A" boilers are now available in 3½ h. p., 5 h. p., and 7½ h. p. capacities, and represent the best of Streammaster's 30 years of design and engineering experience within the small boiler field. A few of the design features are new burner shapes and two pass

baffle system. Manufacturers report the efficient heat transfer of these new boilers gives steam in **less than 10 minutes**, and at larger fuel savings to the boiler owner.

Safety features include automatic feed water and steam pressure controls, as well as low water fuel cut-off that prevents firing a dry-boiler. Has A. S. M. E. Code Approval.

Additional information may be obtained by writing, Steammaster Automatic Boiler Co., 5819 South Compton Ave., Los Angeles, California.

### CONSTRUCTION COUNCIL

E. S. McKittrick, former past president of the Associated General Contractors of Southern California, was recently re-elected to a second term as president of the Construction Employers' Council of Southern California.

A. D. Hoppe, plastering contractor, was re-elected vice-president, and Joe Herman, heating and ventilating contractor was re-elected secretary and treasurer.

### BUILDING EMPLOYMENT

Construction employment in California stood at 170,000 during January, according to a recent report issued by the state Reconstruction and Reemployment Commission. An increase to about 185,000 by May is forecast.

### SHOP

Bids have been received on the general contract for the construction of a shop building for the Wilhows (Calif.) High School, which is expected to cost \$106,000. Masterson & Hurd, San Francisco, are the architects.

### STANFORD DORMITORY

Eldridge T. Spencer & William C. Ambrose, San Francisco architects, are working on drawings for the Crothers Hall Dormitory Building on the Stanford University campus at Palo Alto, expected to cost \$250,000.

## Check those accidents!

Minimize possible damage claims against building owners  
by installing —

**Finlenite Non-Slip Metal Safety Treads**

Standard sizes or made to specification  
CHECKERED, FLUTED, OR PLAIN SURFACES

**GUNN CARLE & CO**  
20 POTRERO AVENUE • SAN FRANCISCO, CALIF.

## METAL WINDOWS

Steel—Aluminum—Bronze

Large Stock—ALL TYPES

Steel Sash Sales & Service

Weehawken, N. J.

## IN THE NEWS

### NEVADA HOSPITAL

Bids will soon be taken on the construction of a new \$175,000 general hospital at Fallon, Nevada. DeLongchamps & O'Brien, of Reno, are the architects.

### KITCHEN-AIRE

Operating on the outside of the wall with only a small grille visible from the inside, a new electric KITCHEN-AIRE SIX ventilator is designed to minimize operating noise and give dependable service.

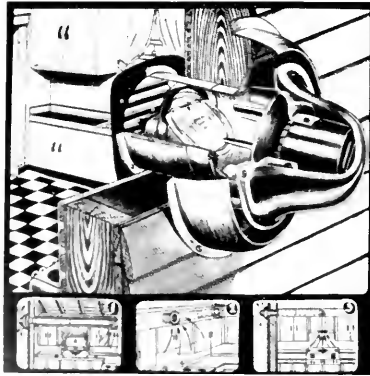

Centrifugal-type balanced impellor operates against static pressures. Only a 6-inch diameter opening through the wall is required; is controlled electrically from wall switch—manufactured by STEWART MFG. CO., Indianapolis, Ind.

### WEST HOLLYWOOD MOTEL

DeWitt Construction Company of Los Angeles is starting work on a 59-room motel at Santa Monica Blvd., West Hollywood for A. A. Allen of Los Angeles. Architects are Bussard & Bussard of West Los Angeles. It is to be a 1-story frame stucco building. Estimated cost, \$95,000.

### VETERANS

More than one-fourth of the veterans on the Berkeley campus of the University of California are registered in the College of Engineering.

## Scott Company

HEATING - - PLUMBING - - TILE



243 MINNA STREET

SAN FRANCISCO

Phone EXbrook 6741

## MULLEN MFG. COMPANY

BANK, STORE AND OFFICE  
FIXTURES—CABINET WORK  
OF GUARANTEED QUALITY  
CHURCH SEATING

Office and Factory:

60-80 RAUSCH ST., Bet. 7th and 8th Sts.  
San Francisco  
Telephone UNderhill 5815

## THE TORMEY COMPANY

GENERAL PAINTERS  
AND DECORATORS

Phone UNderhill 1913

563 FULTON STREET  
San Francisco

## DINWIDDIE CONSTRUCTION COMPANY

BUILDERS

CROCKER BUILDING  
SAN FRANCISCO



## HERRICK IRON WORKS

STRUCTURAL STEEL  
REINFORCING STEEL

18TH AND CAMPBELL STS.  
OAKLAND, CALIF.  
Phone GLencourt 1767

Fine  
ENGRAVINGS

POOR  
RICHARD  
PHOTO ENGRAVING CO.  
320-324 COMMERCIAL STREET  
SAN FRANCISCO 11

## Thomas B. Hunter

Consulting Engineer  
DESIGNER OF HEATING  
AIR CONDITIONING  
VENTILATING AND WIRING  
SYSTEMS, MECHANICAL  
AND ELECTRICAL EQUIP-  
MENT OF BUILDINGS

41 SUTTER STREET  
ROOM 710  
San Francisco California

**George F. Brayer**  
ELECTRICAL  
CONTRACTOR

**166 Seventh Street**  
**San Francisco**

Phone: Market 1761

**PITTSBURGH  
TESTING LABORATORY**

Successors to  
SMITH, EMERY & COMPANY

*Testing and Inspecting  
Engineers and Chemists*

Structural Materials, Structures  
Equipment, Pipe, Soils.

**651 Howard St., San Francisco 5**  
**EXbrook 1747**

**A. F. MATTOCK CO.**

*Builders*

★

**212 CLARA STREET**  
**SAN FRANCISCO**

**INDEPENDENT  
IRON WORKS**

Steel Buildings  
Service Stations  
Steel Storage Tanks  
Fabricated Plate Work  
Steel & Sheet Metal Products  
Fabricated Structural Steel  
Steel Distributors

**Eighth & Pine Sts. Oakland, 7**

**Index to Advertisers**

ALADDIN Heating Corp.	48
AMERICAN Roof Truss Co.	34
ARCHITECTS Reports	40
BASALT Rock Company	Back Cover
BAXTER & Company, J. H.	36
BRAYER, Geo. F.	48
CLASSIFIED Advertising	43
CLINTON Construction Company	44
DINWIDDIE Construction Company	47
FORMERER Cornice Works	39
FULLER, W. P. Co.	*
GUNN, Carle & Company	46
HANKS, Inc., Abbot A.	48
HAWS Drinking Faucet Company	1
HERRICK Iron Works	47
HOGAN Lumber Company	44
HUNT, Robert W., Company	48
HUNTER, Thos. B.	47
INDEPENDENT Iron Works	48
JUDSON, Pacific-Murphy Corp.	39
KRAFTILE Company	32
MATTOCK, A. F.	48
MICHAEL & Pfeffer Iron Works	Inside Back Cover
MULLEN Mfg. Co.	47
MUELLER Brass Co.	*
NORTHERN California Electrical Bureau	35
PACIFIC Coast Gas Association	*
PACIFIC Manufacturing Company	45
PACIFIC Portland Cement Company	5
PACIFIC Telephone & Telegraph Co.	33
PITTSBURGH Testing Laboratory	48
POOR RICHARD Engraving	47
PORTLAND Cement Association	*
REMILLARD-Dandini Co.	48
REPUBLIC Steel Corporation	45
SANTA Maria Inn	44
SCOTT Co.	47
SIMONDS Machinery Company	45
SISALKRAFT Company	39
SMOOT-Holman Co.	37
STANLEY Works, The	30
STEEL Sash Sales & Service	47
TAYLOR Co., Halsey W.	*
TORMEY Company, The	47
U. S. BONDS	2
VERMONT Marble Company	45
WESTERN Asbestos Company	Inside Front Cover
WOOD, E. K., Lumber Company	36

\*Indicates Alternate Months

**A L A D D I N**  
**Heating Corp.**

Specializing in  
QUALITY HEATING  
EQUIPMENT

**2222 San Pablo Avenue**  
**OAKLAND**  
TWinOaks 1022

**ABBOT A. HANKS, INC.**  
**Engineers & Chemists**

INSPECTING — TESTING — CONSULTING  
CONCRETE • STEEL • MATERIALS  
CHEMICAL AND TESTING  
LABORATORIES  
• RESEARCH AND INVESTIGATION •

TESTS OF STRUCTURAL MATERIALS  
DESIGN OF CONCRETE MIXES  
SHOP AND ERECTION INSPECTION OF  
STRUCTURES AND EQUIPMENT  
INVESTIGATION OF STRUCTURES  
AND MATERIALS  
TESTS AND INVESTIGATION OF  
FOUNDATION SOILS  
FIRE RESISTANCE AND INSULATION  
TESTS

**624 Sacramento Street, San Francisco**

**Robert W. Hunt Company**  
ENGINEERS

Inspection • Tests • Consultation  
Schools and Other Structures  
Are Built as Designed

*When Construction Materials are  
Inspected at point of Manufacture  
and during Erection by*

**ROBERT W. HUNT COMPANY**

*Cement, Concrete, Chemical, Metallurgical,  
X-Ray and Physical Laboratories*

Chicago • New York • Pittsburgh  
Los Angeles • All Large Cities  
**San Francisco, 251 Kearny Street**

**REMILLARD-DANDINI Co.**

**Brick and  
Masonry Products**

★

**400 MONTGOMERY STREET**  
**SAN FRANCISCO, CALIF.**

# ARCHITECT AND ENGINEER

"THE STANLEY ROOF," Hotel Sir Francis Drake, San Francisco



1947



**Gas Kitchen  
Planning**

*"Pays Off"*

**in Owners' Good Will**

Here's a "homey", gas-equipped kitchen that can be depended upon to help sell a house or make a profit for the owner. (Note adjacent laundry-room at left.)

No wonder architects and builders are giving more and more thought to the heart of the home—the kitchen.

In the kitchen, or adjacent breakfast nook, most families, these days, eat *most of their meals*. In the kitchen, today's maidless housewife spends the majority of her working hours. It is to the kitchen

that many parties overflow for refreshments, or family and guests repair for midnight snacks.

A charming kitchen such as illustrated above—designed to save steps and effort, equipped for carefree, economical *gas cooking, refrigeration and hot water service* and ventilated to remove cooking vapors and odors—may well be one of your greatest sources of good will in competitive days ahead.

THE PACIFIC COAST GAS ASSOCIATION

The West Prefers  
**GAS**



Other... RESPONSIBLE • FLEXIBLE • ECONOMICAL



# ARCHITECT

# AND ENGINEER

Vol. 169 No. 1

ARCHITECTS' REPORTS—Published Daily  
Telephone DOuglas 8311

E. H. WILDER  
Editor

MARK DANIELS, A.I.A.  
Associate Editor

JOHN S. BOLLES, A.I.A.  
Book Reviews

MICHAEL GOODMAN  
Post-War Planning

L. H. NISHKIAN  
Consulting Editor

E. N. KIERULFF\*  
Ass't Editor  
\*In the Service



## Contents for

# APRIL

COVER PICTURE: "THE STARLITE ROOF," Hotel Sir Francis Drake  
(Page 20)

EDITORIAL NOTES . . . . .	4
NEWS & COMMENT ON ART . . . . .	5
RECENT BUILDING TRENDS The Small Personalized Medical Clinic . . . . .	7
By DANIEL D. GAGE (GRAHAM SMITH, A.I.A., Architect & FREDERICK ALEXANDER CUTHBERT, Landscape Architect)	
CUSTOM MADE—To Fit the Furniture . . . . .	12
By E. M. BUSSARD, A.I.A., Architect (The Newlin Residence)	
ARCHITECT'S ACCEPTANCE OF MATERIALS, As Binding Parties to Contract . . . . .	14
By LESLIE CHILDS	
INSULATION . . . . .	15
By HENRY J. WINGATE, Architectural Engineer	
PREFABRICATION—What Is It? . . . . .	18
MURAL DECORATIONS . . . . .	19
"Starlite Roof," Hotel Sir Francis Drake, featuring JOHN GARTH, Artist	
HOTEL SIR FRANCIS DRAKE "STARLITE ROOF" . . . . .	20
THOMAS & MERET, Architects; W. ADRIAN, Engineer; WALTER M. BALLARD CORP'N, Designers; HARRY S. MOYER, General Manager	
A.I.A. ACTIVITIES . . . . .	31
WITH THE ENGINEERS . . . . .	32
HEADLINE NEWS & VIEWS . . . . .	36
By E. H. W.	
IN THE NEWS . . . . .	37, 38, 46, 47
ESTIMATOR'S GUIDE, Building and Construction Materials . . . . .	41
BUILDING TRADES WAGE SCALES, Northern and Central California . . . . .	43
CLASSIFIED ADVERTISING . . . . .	43
BOOK REVIEWS, Pamphlets and Catalogues . . . . .	45
INDEX TO ADVERTISERS . . . . .	48

ARCHITECT AND ENGINEER (Established 1905) is published on the 15th of the month by The Architect and Engineer, Inc., 68 Post St., San Francisco 4; Telephone EXbrook 7182. President, K. P. Kierulff; Vice-President and Manager, L. B. Penhorwood; Treasurer, E. N. Kierulff.  
Los Angeles Office: Wentworth F. Green, 6605 Hollywood Blvd., Los Angeles 28, Telephone HEmpstead 3171.

Entered as second class matter, November 2, 1905, at the Post Office in San Francisco, California, under the Act of March 3, 1879. Subscriptions United States and Pan America, \$3.00 a year; \$5.00 two years; foreign countries \$5.00 a year; single copy 50c. ARCHITECTS' REPORTS are published daily from this office, Vernon S. Yallop, Manager.



# EDITORIAL NOTES

The Annual Convention of the American Institute of Architects will be held April 29-30, May 1st in Grand Rapids, Michigan.

## THE PROFESSIONAL TRAINING OF THE ARCHITECT

Since the basic function of architecture is to deal with the living problems of human beings, the role of the architect combines those of the psychologist, the philosopher, the technician, the administrator, and the artist, in addition to the more obvious duties of the profession.

Architecture deals with LIFE—with the physical and psychological problems of human beings—their living, their movement, their work, their play, and all the other phases of human activity. It is the interpreter of a philosophy of life at the time of conception. It is concerned with buildings only as a part of the pattern, because the fabric is made up of much more than structures, their planning and design.

As living itself has grown more complex, so the problems of the architect have become greater in number as well as more involved in their significance. One entering the profession today must have a clear understanding of its relation to the life it is attempting to express, in order that architecture may fill its proper role of maintaining clarity of living in the confusion of change. The architect must see his work in relation to the community . . . Not only must he be able to perceive what is needed, but he should be able to evaluate his observations and balance the resulting requirements so as to gain the most satisfactory results. . . .

One of the chief functions of the architect is to make clear the necessary integration of a twentieth-century planning and design. . . .

Professional practice obviously involves law, engineering (electrical, mechanical, and civil), geology, trade, transportation, economics, and so on. According to his individual interest, an architect may follow one of these branches of the profession more or less exclusively, without devoting his principal effort to the designing or planning of particular structures. . . .

Although it is necessary for every architect to be conversant with these many related problems, it is impossible for him to be fully trained in all of them and consequently there is opportunity for a certain amount of specialization within the profession. . . .

. . . An Architect Deals in Ideas, and the graphic presentation is used only in order that others may readily understand these ideas.—Excerpts from an

article by Douglas W. Orr, A.A.I.A., New Haven, Conn., which appear in ARCHITECTURE, A Profession and A Career, published by the American Institute of Architects.

We wonder what will be done with the makeshift sign-board service rosters currently adorning many City and County grounds and buildings?

## SMALL TOWN BUILDING OPPORTUNITIES

A recent survey conducted by a nation wide organization indicated the largest market for building materials at the present time is in cities of less than 50,000 population.

This is a reasonable conclusion when you consider that since late 1941 practically all major construction and much of the reconstruction activities of the Nation have been centered in metropolitan areas in conjunction with wartime industrial and emergency housing projects.

The shift of population during the past few years has been into these industrial districts where employment at high wages was assured, and where some people felt they could best make a personal contribution to the war effort and thus satisfy a patriotic desire.

Now that the War is over and it is obvious many of the war-jobs and high compensation is a thing of the past, the population shift is towards the smaller cities and communities.

Returning war veterans and workers find the building of residential and commercial properties in the non-metropolitan, non-war emergency areas has long been neglected.

When you consider that in 1941 more than 66 per cent of all homes built were located in 16,000 towns of less than 50,000 population, and that for the past six years there has been practically no building in these localities, it is no wonder the small town offers a tremendous building opportunity.

A Million Business Men will be represented at the annual meeting of the Chamber of Commerce of the United States in Washington, D. C., on April 28 to May 1st—will they charter a national economy of peace or chaos?

So many commissions and committees are being appointed to consider a second San Francisco Bay crossing—may we suggest a committee whose duties would be to appoint the commissions and committees.

# NEWS AND COMMENT ON ART



Oils  
by  
Wm. Egon Wiedemann

## M. H. DeYoung Memorial Museum

### WILLIAM EGON WIEDEMANN

Enrolling at the Academy of Munich, in the city where he was born, he studied under the great teacher, Habermann.

Later he traveled to Berlin, Paris, and Italy and with the coming of World War II he went to South America.

His stay on the West Coast is only for the duration of his current exhibition.



## CALIFORNIA PALACE OF THE LEGION OF HONOR

Thomas Carr Howe, Jr., Director, has announced the following schedule of exhibitions and special events for the latter part of April:

**EXHIBITIONS:** — Paintings by Karl Knaths; Gouaches by Dorr Bothwell; views of European Cities, prints from the collection of Moore S. Achenbach; the Alma de Bretteville Spreckels collection of Sculpture by Auguste Rodin; the Mildred Anna Williams Collection of Paintings, Sculpture, Tapestries and Furniture; and the Collis Potter Huntington Memorial Collection of 18th Century French Paintings, Sculpture, Tapestries, Furniture and Porcelain.

**CHILDREN'S ART CLASSES:** — Ages 4 thru 12, each Saturday morning at 10:30, with instruction by Katherine Parker, Lilly Weil Jaffe and Rex Mason. Admission free.

**ADULT PAINTING CLASS:** — Under direction of Rex Mason each Saturday afternoon at 2:30. Admission free.

**SPECIAL PROGRAMS:** — Organ recital by Uda Waldrop, each Saturday and Sunday afternoon at 3; Free Motion Pictures Saturday at 2:30.

## SAN FRANCISCO MUSEUM OF ART

The Museum's potpourri of April exhibitions and activities should prove more stimulating to a wider circle of visitors than usual. Representational (Oliver Albright) vs. (John Baxter); New Photographs and drawings and prints by Mexico's foremost graphic artist, Fernando Mendez, and 11 paintings submitted by American and European painters for The Temptation of Saint Anthony, invited to participate in the Bel Ami International Competition of Loew-Lewin Production of Hollywood.

Neither sculpture nor jewelry have been shown in the galleries for many a month. The sculpture, in metal, stone and wood, which corresponds in its abstractness roughly to the painting of Dove, will present for the first time in solo-show a young local artist, John Baxter whose work heretofore has only been seen in the two last annuals.

The Modern Jewelry Design shows that today's jewelry need be neither the "princely luxury of precious stones and metals nor the dubious glitter of production-line gadgets." In addition to silver and gold, the variety of materials used by the twenty-five craftsmen-designers, whose work is shown, includes brass, chrome-nickel steel, bone, plastic, native stones, marbles, hardware and even safety pins. The exhibition includes such professional craftsmen as Margret de Patta of San Francisco, Turner, Lobel and others and "amateurs"—

painters, sculptors, a motion picture director and an art dealer, such as Calder, Lipchitz, Bertoia, Julio de Diego and Julien Levy.

The solo shows of work by Dove and Albright are both memorial exhibitions. Oliver Albright, an artist of wide local repute, died in 1944, and will have some fifty of his works shown. Arthur Dove, dead not more than six months, followed by only a short time his great admirer and exhibitor Alfred Stieglitz. Although most of his things come from New York, a number of items have been added from private collections in the Bay Area.

**ACTIVITIES:** — Children's Saturday morning Art Classes will continue to May 17th; Adventure in Music, 3rd Monday of each month at 8 p.m.; Flower Decoration, lecture demonstration (four meetings) beginning April 24th at 2:30 p.m. on Wednesdays; and Workshop study of color and composition, a group of 8 meetings on Mondays 7 to 9:30 p.m. beginning April 7th.

## CITY OF PARIS ART IN ACTION SHOP

An Exhibition of Oils and Watercolors by George Harris, David Park, Ina Perham Story, and Florence Swift will be shown in the Rotunda Galleries from April 2 to April 26th; while Art In Action will include demonstration of hand weaving daily 10 a.m. to 3 p.m. and pottery thrown on the wheel Tuesday and Thursday 11:30 a.m. to 4:30 p.m.

There will also be an Exhibition of Watercolors by Midori Hanamura.

The Pacific Coast Ceramic Exhibition and Sale by sculptors and potters of the Pacific Coast has been set for May 6 to June 7th with the Jury of Awards consisting of Laura Andreson, Whitney Atchley, Vivika Timiriaseff, Ruth Cravath Wakefield, Edith Heath, alternate, and Beatrice Judd Ryan, Director.

## M. H. DE YOUNG MEMORIAL MUSEUM

**EXHIBITIONS** scheduled for April will include: **OILS** by Constance Richardson, opening April 3rd; **ORIGINAL DRAWINGS** — San Francisco Before the Fire, 1906, by Will Willke, opening April 18th; **TEXTILES** For You and Your Home, by the Contemporary Handweaver's Association of California, opening the latter part of April; **WOODCUTS** and Drawings by Reinhard Schmidhagen, and Chinese Lowestoft Porcelain.

**ART CLASSES FOR ADULTS:**—Conducted by Charles Lindstrom.

A new series of **PAINTING FOR PLEASURE**, will begin in April. The course will be given twice: Saturday mornings from 10:15 to noon, beginning

(See Page 44)



**GRAHAM SMITH, A.I.A., Architect, Eugene, Oregon**

# RECENT BUILDING TRENDS

## The Small Personalized Medical Clinic

By **DANIEL D. GAGE\***

Doctors and dentists are returning home with terminal leaves from the army and navy in their pockets only to find no place in which to relocate. Suitable space either in office buildings or in specialized medical-dental buildings has been gobbled up. "No vacancy" signs are confronting them

*\*Author's identity: Ph.D.; Associate Prof. of Bus. Admin, University of Oregon; instructor in real estate and appraising; Real Estate Analyst, Wakefield-Fries-Woodward, Inc., Portland, Ore.; formerly, Aug. 1942-1945, Rent Executive for Oregon, Office of Price Administration.*

wherever they go seeking space either for office or housing accommodations. They are faced with three possibilities, take makeshift space where they can find it, move to another community where space can be found and wait for the breaks, and last, produce their own space by building.

There is then a revival of the trend that was apparent just before the war. Impetus to the new trend towards the small medical and dental unit was given several decades ago with the development of the special purpose medical-dental building. It probably started this way: there was first the small community hospital in which local doctors pooled their various abilities, capital, surgical and therapy equipment. Paralleling this tendency was one in



**FREDERICK ALEXANDER CUTHBERT,**  
Landscape Architect,  
Eugene, Oregon

which doctors grouped themselves into small partnership arrangements for sharing of common quarters or even a common medical practice. As the era for medical specialization materialized, physicians became more aware of their interdependence upon one another. The Brothers Mayo had pioneered the way. It was natural then for doctors to follow the herd instinct and congregate in one or two office buildings in the community.

However, the traffic problem on streets, in hallways and elevators made it difficult for patients as well as doctors to make visits. To rectify this condition, the idea of a special building to house only doctors and dentists adjacent to the hub of the city bloomed forth. These buildings sprang up in the 1920's and 1930's all over the country. Some met with immediate success, others were financial failures or never reached the completed stage when the depression of 1930 struck. Unfortunately there were many unwise promotions. In many instances competitive buildings were erected in situations where the community could only support one. In other cases shoe string financing and incompetent management cooled many doctor's ardor for this type of medical office housing.

The centralized medical-dental buildings, however, are probably here to stay. On the other hand there was a parallel movement underfoot—that towards the smaller, decentralized and more personalized medical units. Many doctors, sometimes by necessity other times by preference continued

to practice in residential homes. Either the entire house was given over to offices or a few rooms were devoted to medical offices and the remainder served to house the doctor's family. It was but a step then to build a small structure for the special purpose of medical practice and remove the odium attaching to makeshift or combination quarters. The practice of neighborhood medicine, however, had established itself. As traffic began to sweep around the large medical buildings, it was more apparent than ever that the decentralization movement was underway.

A factor which many physicians overlook is patients' fear. Also there is the natural inertia to put off that medical call because the office is often hard to get to. Hospitals and even medical offices of the customary type set up what might be called "threshold resistance". To cross the threshold of an imposing but cold building which has all the atmosphere and odor of a hospital shoots a mental chill down the spine of the average patient. If he could only go to an office in a building more personalized and more like a home, some of his fears and inertia might be dissipated.

Doctors who are putting away in moth balls their tan blouses to don again their white ones for civilian practice are remembering some lessons gained in their wartime experience. They see more clearly than before the advantages that come with working together in close knitted groups where it is no reflection on their professional reputation to turn freely to others for advice. Yet, they also see the disadvantages of too much systemization and regimentation that may come from too large groupings or centralization. They seek a middle ground. It is not unlikely then to see more small, detached medical units in neighborhood and sub business centers of the city in the near future.

The small personalized medical or dental building has these forces as developmental factors:

- (1) Present shortage in regular office, or medical dental buildings.
- (2) Trend away from down town locations with their attendant traffic and parking problems.
- (3) Trend towards neighborhood locations in small simple buildings which cut down patient's fear and inertia elements.
- (4) Trend towards group of a size to secure advantage of specialization, pooling of equipment and capital, and eliminate disadvantages of practice in centralized medical building.

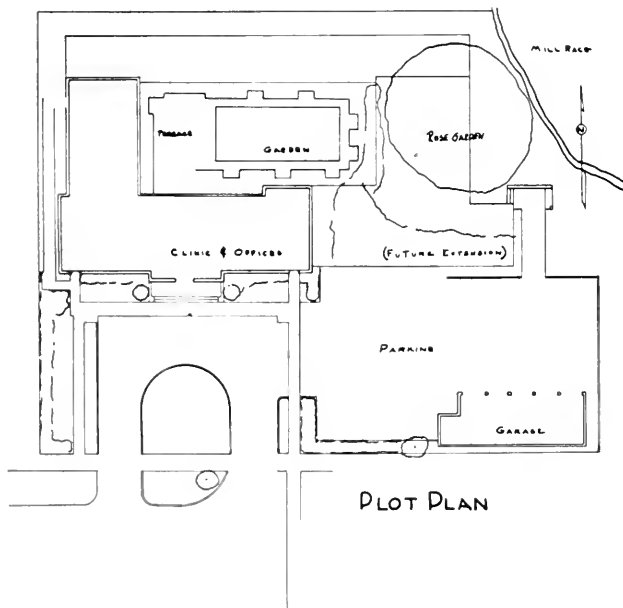

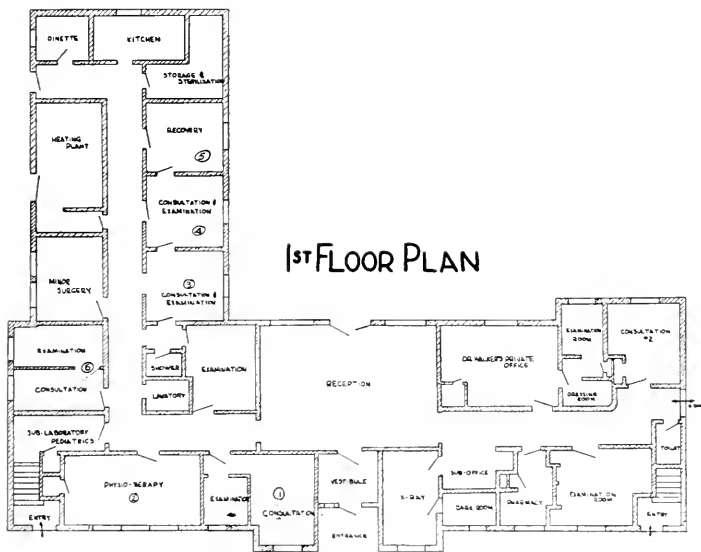

1ST FLOOR PLAN

**FIRST FLOOR PLAN** shows convenient and utility location of Reception Room, Dr. Walker's private office, Examination Rooms, Minor Surgery, Laboratories, X-Ray, Pharmacy and Kitchen.

**THE SECOND FLOOR PLAN** shows use of space for additional kitchen facilities, dining room, executive offices and living rooms.

2ND FLOOR PLAN

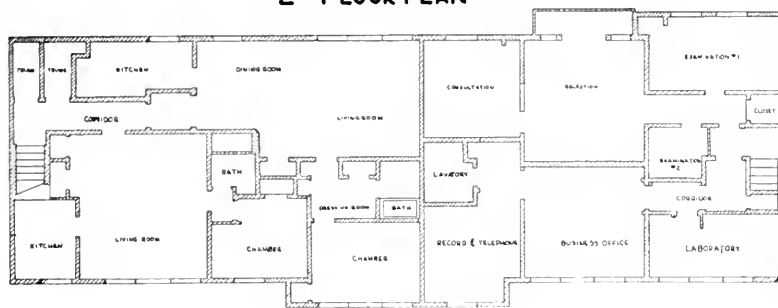



**DR. WALKER'S Private Office  
and Study**

(5) The persistence of the neighborhood doctors in neighborhood locations, a situation which has withstood all attempts at centralization.

**Walker Clinic Building As An Example**

There are a number of small and specially designed medical buildings already in operation throughout the country. Some doctors were fortunate to have completed them just before the outbreak of the war. The Walker Clinic building in Eugene, Oregon is a concrete example of what can be accomplished with good planning and foresight.

Pictured is a development by Dr. Milton V. Walker in 1941 but being altered and adjusted

this year to fit the changing pattern contemplated at the start. It is a complete departure from the conventional type of doctor's office and building. In selecting the site, quietness, proximity, and natural setting were paramount factors. The location is three and one-half blocks from one semi medical-dental building which is close to the heart of the city, four blocks from the general hospital, and at the juncture of two dead end streets. The site in a transitional but good residential district has the distinct advantage of natural full grown trees and a water course bordering one side known as the "old mill race". Considerable effort was spent in landscaping the grounds with both annuals and perennials. The rose garden is one of the show



**RECEPTION ROOM: Looking East—note door to medical offices at right and magazine and pamphlet reading rack at left.**



places of the city. The site also provided area for future expansion.

The building exterior as can be seen from the illustration gives no outward indication of thermometers and white uniforms. There is no mental obstacle in crossing the threshold just as there is no impediment in arriving at the front door, for adequate private parking space is available. Inconspicuous is the sign divulging the function of the building, "Walker Clinic". Usual home construction was used by the architect, Graham Smith. Except for the brick veneer front, wood siding was used for weatherboard. The roof is shingled with red cedar. There is no basement, the furnace room being at ground level.

### Interior and Floor Plan

The original plan was to erect a building which would house on the first floor, offices, examination and treatment rooms of several associated doctors and a dentist. As there was considerable pioneering risk involved in a special purpose building, it was decided to make a layout which could be readily converted at low expense depending on the outcome of events. As a result the second floor was made into apartments separated from each other by skeleton partitions. These were rented to staff members. The rear wing (one story) was so designed that it could serve either as a small hospital or for additional office space as the need arose.

With the outbreak of the war, and the resulting shortage of hospital space in the city, the rear wing initially served the function of a small hospital. With the pressure released after the war, but with the increased need for more office space, this wing was converted this year to auxiliary medical

rooms. So greatly did the medical practice expand in the clinic that even this conversion did not provide sufficient space. As a result two of the upstairs apartments were converted to business office space, laboratory, O.B. examination rooms and reception.

### Reception Room the Focal Point

The focal point, the general reception room is placed in the center of the building. It is 17x26 and the entire north wall opposite the entrance is composed of French doors and full length windows looking out to the rose garden. A broadloom rug, bright papered walls, celotex squares for the ceiling, lighted oil paintings are foundations for the decorative effect. The result is the production of a definite home atmosphere with all the charm of a tastefully furnished living room.

Radiating from east and west are entrances to corridors leading to the medical offices of the various doctors, treatment rooms and to downstairs business office. Traffic is diverted after entrance to avoid the congestion so often found with happen chance arrangement of many doctor's offices.

If you have doctors and dentists as friends or clients who are facing the problem of properly housing their medical practice, it might pay to suggest to them, this idea of the small personalized and detached medical office building. In the example just given, it has clearly been demonstrated by a five year record, that with proper site selection, sound planning, provision for future site changes and need, and most important, recognizing the requirements, demands, and obstacle complexes of the patient, not only does the investment quickly pay for itself, but it is a decisive factor in developing a larger volume of medical practice, and consequent increase in income.



**FLOOR NURSE** desk and another view of the Reception Room with glass doors leading to lawn and landscaped section at side and rear of building.

# CUSTOM MADE

## —To Fit the Furniture

By E. M. BUSSARD, A. I. A., Architect

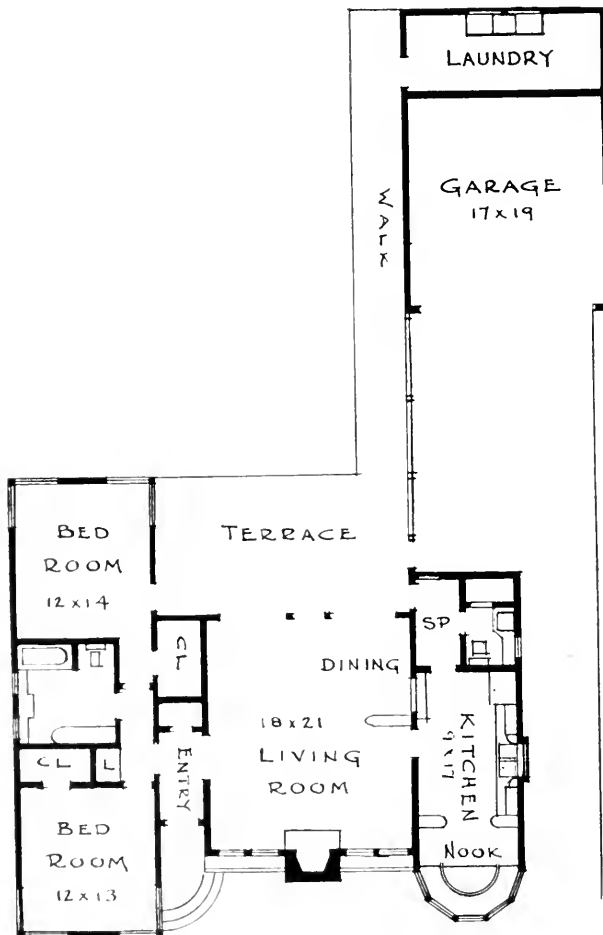

NEWLIN RESIDENCE

When Mr. and Mrs. Max Newlin built their home there were two conditions which had to be met. The first was a wartime limitation on the area of the house and the second was the need to fit the house around the very beautiful and very modern furniture which Mr. and Mrs. Newlin owned.

The area limitation was overcome to some extent by combining the living and dining room thus making possible a spacious room and still not losing a dining space. The dining and living areas are separated by casework which serves also as storage space and a decorative element. The walls are panelled in beautiful paper—a perfect hardwood imitation, lacquered for durability. The lush sherry red corner couches by the fireplace were one of the pieces the house was built to fit and the sea green upholstered benches of the corner dining room group was another. These with a sea green curved lounge with spotted leopard hassock and pillows, the brilliantly colored California landscape over the fireplace and the clever knickknacks make a gay and smart ensemble. Across the entire back of the room is a wall of glass giving a view of the covered terrace and garden.

The terrace connects with a covered passageway to the garage and laundry room in back of it. You also enter the house from the terrace through a service porch in which are roomy closets for storage of canned foods, household

(Photos by Bob Cleveland)



**Entrance—  
is attractive**

tools, etc. Off this room is a lavatory—convenient for washing up after working in the garden—and then comes the kitchen! It is shining white with a hood over the stove and gleaming tile board back of it for easy cleaning. At the end is a huge, inviting, circular breakfast nook gaily papered in red roses and green leaves and with a bright red leatherette upholstered seat and red topped semi-circular table.

One of the bedrooms does double duty as a den being papered in the same hardwood panelling and decorated in a colorful morning glory patterned chintz at windows and on the couch. The

**BELOW is sitting room**



**Combination dinette and kitchen**

master bedroom has a large dressing closet with built-in wardrobes and shoe cabinets. The bath is a tricky place with a glass cabinet for displaying the bright colored towels and a dressing table with a large mirror. The walls have a wainscot of smoky blue tileboard and above is an intriguing bubble paper.

The exterior was designed to express the smartness and sophistication of the furnishings within. The house has long horizontal lines with wide eaves—a massive flagstone chimney and flagstone planting boxes—and a combination of cream stucco and white wood walls.

# ARCHITECT'S ACCEPTANCE OF MATERIALS— AS BINDING PARTIES TO CONTRACT

By LESLIE CHILDS

Where, by the terms of a building contract, an architect is made the judge of the sufficiency of performance and materials, his word thereon will be final. But, when a decision has been rendered, the architect may not, in the absence of fraud or mistake, reverse himself to the injury of the contract parties.

It follows, a final judgment on a point will exhaust the architect's power thereon; the parties will be bound thereby, and any attempted change by the architect of his judgment will lack legal force. A nice point this for architects to have in mind when passing upon work or materials. And, as an example of judiciary reasoning thereon, the following case may be examined with interest and profit.

## ARCHITECTS REVERSE THEIR ACCEPTANCE OF MATERIAL

Here a contract was awarded for the construction of a school building. The contractor then contracted with an architectural stone manufacturer for material to be used in the building. The contract between the contractor and the school district, which concededly applied to the stone manufacturer, provided:

"The decision of the architects as to the true intent and meaning of the plans and specifications shall be final and binding upon both parties to the contract."

The stone manufacturer proceeded under its contract. Its product was approved by the architects, both at the plant and at the building site, upon arrival. When substantially 85 per cent of the material had been delivered, the architects reversed themselves and notified the contractor that all of the architectural stone furnished was rejected.

This about face, it appears, resulted from an agreement between the school district and the contractor to use another stone in the building. The stone manufacturer then demanded payment for the material that it had shipped and had been accepted by the architects.

A law suit followed. Here the main question raised was as to the right of the architects to reject stone, after having accepted it, and so relieve the contractor from liability to pay for same. The lower court found in favor of the stone manufacturer, and the higher court in affirming the judgment reasoned as follows:

## THE LANGUAGE OF THE COURT

"It is not uncommon to provide in building and construction contracts that an architect or engineer shall pass upon the quality of materials furnished and shall have power to reject the same. If it be conceded that under the contracts and the plans and specifications in this case the architects were so clothed with such power and did reject the material, the legal question arises as to whether or not such power of rejection can be exercised after the architects have approved of the material.

"In contracts of this kind the architect is in a very proper sense an arbitrator. \* \* \* The general rule is that when the architect \* \* \* has exercised his authority and made a finding, he cannot subsequently reverse his decision and make a different finding. \* \* \*

"Under the evidence the jury might have found that the material furnished by the (stone manufacturer) was all of the kind and quality called for in the contract \* \* \*, and that it was inspected, approved, and accepted by the architects. If the jury found this true, the architects could not thereafter, under the terms and provisions of the principal contract, reject the material. \* \* \*

"It would be a harsh and unreasonable construction to place upon such a contract to hold that under it the architects could accept all of the material furnished by (stone manufacturer) and thereafter summarily reject it and by so doing absolve the (contractor) from liability \* \* \* to pay for the material furnished. Such is not the law, \* \* \* We find no error \* \* \* the judgment \* \* \* is affirmed." (220 N. W. 197)

## CONCLUSION

So ended the case. And, on the facts involved, the holding is in accord with the great weight of authority. The latter taking the position that when an architect renders a final decision, under a building contract of this character, he has exhausted his power on the point covered.

Perforce the parties to the contract are bound thereby, and, in the absence of fraud or mistake, the architect may not thereafter reverse his decision to the prejudice of the parties to the contract. And, as an illustration of judicial reasoning in the application of this rule, the case reviewed is one of force and value.



Granular mineral wool insulation being pneumatically applied to a roof. After the space between joists is filled to a depth of four to six inches, the roofing material is replaced and made water-tight.

# INSULATION

By **HENRY J. WINGATE, Architectural Engineer**

Now that the homebuilding industry is gradually beginning to find itself in a competitive market with prospective buyers shopping around for values instead of grabbing the first house offered, many builders are hastening to meet these demands.

And they can meet them, too. Unlike the situation that prevailed prior to December 14, 1946, the date that ceiling prices went off new homes, buyers can now pay and are willing to pay a few hundred dollars more for refinements that builders could not give them under the old ceiling regulation.

It is trite, but never more true, that a home represents the biggest purchase the average family will make in its lifetime. Most families know what they want because in most cases years of planning have gone into its "dream home."

Among the bigger wants revealed in recent surveys over the nation are fireplaces, complete thermal insulation, wide picture windows, gas heat, quality plumbing, metal weather-stripping, kitchen large enough for a breakfast set without cramping, space that can be converted into a game room, and so on.

Not only do the buyers want these features for

their own use, but they know that in case of emergency and the home ever has to be put on the market, it will have a better resale value than just another house.

Insulation against heat and cold ranks at the top of the list of demands for extras. Approximately 87 per cent of all prospective home-buyers recently questioned said they wanted their houses thus protected and were willing to pay for it. The survey showed they didn't know too much about insulating, but they did realize that it would provide greater year-around comfort and that there would be some sort of saving in fuel bills.

From this, it would appear that the smart builder would install this extra and add it to his selling price. Although full-thick fireproof in walls and ceiling insulation is roughly figured at about 3 per cent of the cost of the home, a substantial portion of this is saved in initial cost of the heating plant because a properly insulated house requires a smaller furnace and less radiation.

The few prospects who would balk at the addi-

tional charge would be more than offset by buyers who would not.

As the competitive market continues to gain momentum, the builder who has erected a full-insulated house will find that he has many ready-made selling arguments not possessed by his skimping competitor.

In the first place, nearly one-half the fuel bill can be saved. Authority for this is the University of Illinois which says 50 of the 104 fuel units required to heat a typical one-story brick or stucco veneer on frame house can be saved, provided the house is equipped with storm sash and four inches of insulation is placed between the attic joists with a 3 $\frac{5}{8}$ -inch blanket between studs or furring from foundation to attic.

If mineral wool is used, it can be pointed out to the buyer that the United States Bureau of Mines recommends this material because of its resistance to fire, electrical short-circuits, termites, vermin, moisture and decay. Bureau of Mines figures



Insulation crew works between roof and top-floor ceiling

show that mineral wool has the lowest thermal conductivity of any commonly used insulating material.

Likewise, the fire safety that comes with mineral wool should be of prime interest to the prospective buyer. Because it is made of rock, smelter slag, or sand, it cannot burn. National Bureau of Standards tests show that a wool-lath wall completely filled with mineral wool will stop the passage of fire for one hour through what would otherwise be a natural flue. All builders know that most building codes recognize mineral wool as an effective fire-stop.

Another talking point is that a completely insulated house needs to be redecorated only about one-third as often as one that has no insulation. The reason is that insulation brings wall and ceiling temperatures to within 3 degrees of the interior air. Dust and moisture, which are always carried upward when artificial heat is turned on, will not be deposited on warm surfaces as rapidly as on cold ones, nor will dust circulate as rapidly.

Recognition of the importance of wall insulation is not sufficiently widespread because the public has the conviction that heat rises and does not go sideways. Hence, it is assumed that ceiling insulation is more important than wall insulation. However, the previously mentioned University of Illinois test showed that 16 fuel units were saved by insulating the walls full-thick.

The public does not know enough about the effect of cold wall temperatures on comfort. Engineers, however, know that **heat loss per square foot** through walls is almost as heavy as through ceiling. Discomfort is far greater because of human proximity to walls, and when they are 10 degrees below the air temperature (which is the case when outside it is zero and the inside air is 65 degrees) body heat radiates rapidly to the walls.

Another thing the public should be set right on is the cost of insulating walls of new homes. The average man thinking about a home knows that it costs less per square foot to insulate a ceiling with mineral wool than a wall because walls are inaccessible. He has discovered this through conversations with applicators specializing in work on existing houses. He knows virtually nothing about new construction. As a matter of fact, it costs no more—possibly less—to insulate walls in new construction than it does ceilings.

In any event, complete full-thick insulation is generally recommended by engineers, and mortgage lenders are beginning to ask for it because they know it makes the house a better mortgage risk, both for fire-safety if mineral wool is used and for a greater resale value.

## PLANNING

Fifty-three of California's 58 counties and 171 of its cities now have planning commissions, the state Reconstruction and Re-employment Commission points out in its recently published pamphlet, "California Reports on Planning."

Planning, the commission feels, can be broken down into five basic steps: 1. Look around—find out what actually exists physically and functionally, assets and liabilities; 2. Look back—find out what has been responsible for the conditions existing and take advantage of the many lessons that can be learned from what has already happened; 3. Look ahead—determine what the desirable objectives are and what can be done to provide better health, safety, comfort and security for the citizens as well as to conserve and develop physical and human resources; 4. Set the course—using the assembled facts and agreed upon objectives as a basis, formulate a general plan which will set the pattern for future development; and 5. Do something about it!—The plan is not an end in itself, but a means to an end. Plans which are put on the shelf are as useless as a blueprint of a building that is never built.

As an example of what can be done, the commission analyzed the city of Sacramento and prepared a report on its work, "Forecasting a City's Future: Sacramento, California." The study analyzes the basic patterns and trends of income, population and employment and shows how changes and rates of change of these factors may be interpreted to give clues to a city's future growth.

While the study relates to Sacramento only, the methods and procedure can be applied by planning commissions and other organizations to foretell and assist in molding the growth of other communities.

---

## APPRENTICES

Building industry apprentices number approximately 105,000 at present, according to the Apprentice-Training Service of the Department of Labor. Industry spokesmen predict this will fall short of coming needs, though it is greater by three or four times than any previous peak.

---

## MARKET SOFTENING

The residential real estate market is softening up, with some exceptions. Transactions are still numerically above the 1945 peak, but there is definite evidence of buyer resistance on both new and old houses.

A recent statement of the U. S. Savings and Loan League indicates that the peak has passed on old houses, and prices are now expected to level off.

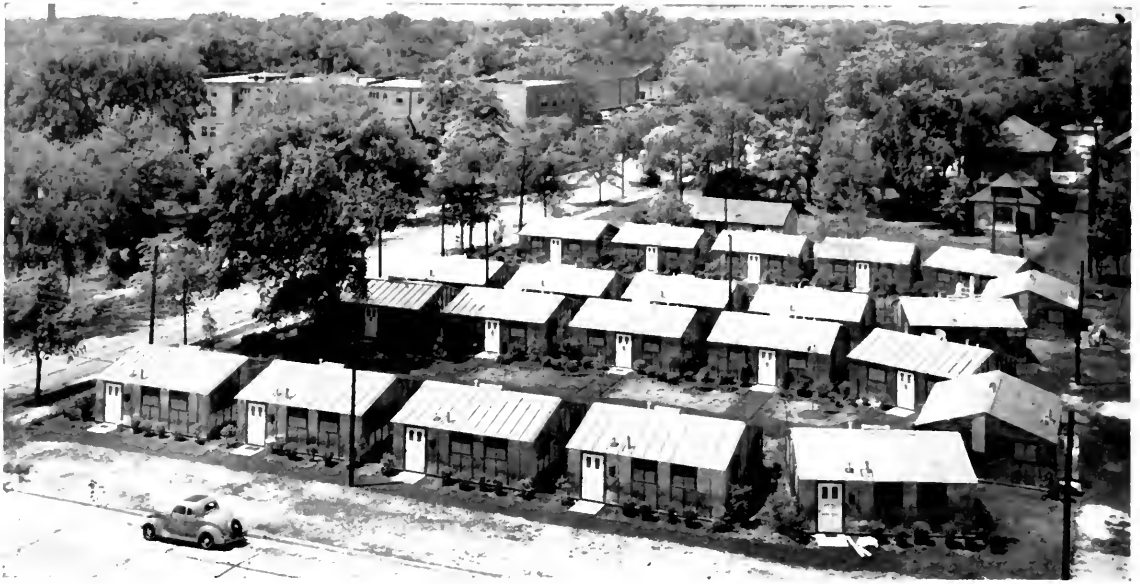

This aerial photograph shows part of a project which is alleviating the housing shortage at Northwestern University, Evanston, Illinois. The homes were furnished by The Steelcraft Mfg. Co. of Cincinnati, Ohio, who shipped all parts in convenient bundles to the campus grounds. The entire project, which now provides shelter for approximately 1000 veterans and faculty members, was completed within 90 days.

# PREFABRICATION

## —What is it?

Thousands of home-seekers across the country, desperately searching for a solution to their most urgent personal problem, are centering their attention on the magic word "prefabrication."

What is prefabrication? The word has been so bandied about that it has come to mean many different things to many different people.

Technically, prefabrication as the term is applied to a home is where the floors, walls, ceilings and roof comprise sections or panels which were fabricated in a shop or factory prior to installation or erection on a foundation.

It is diametrically opposed to the process by which the conventional-type home is constructed piece by piece on the building site.

The cutting, fitting and forming of sections or panels are all done at the factory. The sections are then transported to the home site and assembled according to furnished instructions.

Editor's Note: This article of prefabrication was adapted from a radio address by Mr. Al Levinson, President of The Steelcraft Manufacturing Company of Cincinnati, Ohio.

This saves costs and other details. Much of the field work is cut to a minimum.

Prefabricated homes may be constructed of wood, concrete, steel, aluminum and other materials or parts of all of them. Whatever the material used, the prefabricator's basic purpose is to design the home in such a way that component parts can be produced on a large-scale basis. With the object, of lowering construction costs.

### Pre-Cut Lumber

It has long been the practice of lumber and mill men to cut lumber for various parts of the home. It then had to be fitted to its particular purpose at the job site.

The next step is to pre-cut the lumber to precision for floors, walls and roof. The saving of time and expense is obvious.

However, for one reason or another, prefabrication did not progress any further than this for some time. Certain elements in the building industry, contrived to block it. Ill-advised operations by irresponsible or inexperienced persons also served to give the cause of prefabrication a black eye.

(See Page 30)





# MURAL DECORATIONS

## "Starlight Roof" of Hotel Sir Francis Drake

Painted by John Garth, Artist

The stimulating murals decorating the Drake's Starlight Roof, portray the various familiar star-clusters, arranged in two separate groupings, and presented somewhat as they were first pictured in the imaginations of the early Greek poets, about 300 B.C. These mythological star figures, although actually overlapping, crazy-quilt fashion, in the sky, are here arranged in two contrasting sequences, the animals and the people. Thus the long, curving panel behind the bar presents a sort of Heavenly Zoo, arranged in a continually surprising, yet pleasingly balanced running pattern. It brings together "Pisces," the fishes, "Taurus," the Bull, the two bears, (the big and little dippers) "Leo," the Lion and all the rest, painted in icy grays and blues, as though constructed of air, mist and imagination, each figure sparkled with its punctuating stars and all held together by the slender, interlacing fire-trails of swooping comets. Despite the theme's classic derivation, the striking treatment here realized has resulted in something both original and modern in feeling, achieving an arresting sense of the novel and unique.

The back-bar panel (top) was executed on finished white plaster, primed for oil pigment, the colors ground in Japan to insure complete flatness and blended with flat, "washable-wall" white. The pansy-jet sky background was set in with W. P. Fuller's "Velvet-Black Decoret," in an effort to achieve the maximum effect of recession. The entire panel is lighted by a double-length of white neon at the base, masked by an 8' chromium baf-

fle, and a secondary illumination derived via the rose glow from the underlighted, glass bar top.

The main room ceiling (shown below) presents another aspect of the mythological personification of the more prominent constellations, those human figures which are usually referred to as "The Royal Family of the Sky"; the old King Cepheus, his flighty consort, Queen Cassiopeia and their lovely daughter, Andromeda. There are also the hero, Perseus, and his winged horse, Pegasus, all traced on the Drake Roof's ceiling in slender outline around the stars that form their framework.

This ceiling mural was executed in two colors of fluorescent pigment on rough acoustical plaster, the figures themselves in white which changes to sky blue when lighted and the stars in yellow-white which glows like colored fire when activated at night with "black light." The dry plaster was first sprayed with flat blue oil color and then the figure outlines and the stars were painted on in white pigment, casein color being used to separate the fluorescent solution which followed, from any chemical effect the plaster might have on it. The two decorations took six weeks to execute.

Garth has two degrees from Yale (B.A., B.F.A.) and, as the critics put it, . . . "combines flawless drawing with a vivid sense of pictorial beauty and a natural feeling for large design." Garth studied extensively in Europe before coming west and is a member of the National Society of Mural Painters in New York. He makes his home in San Francisco.

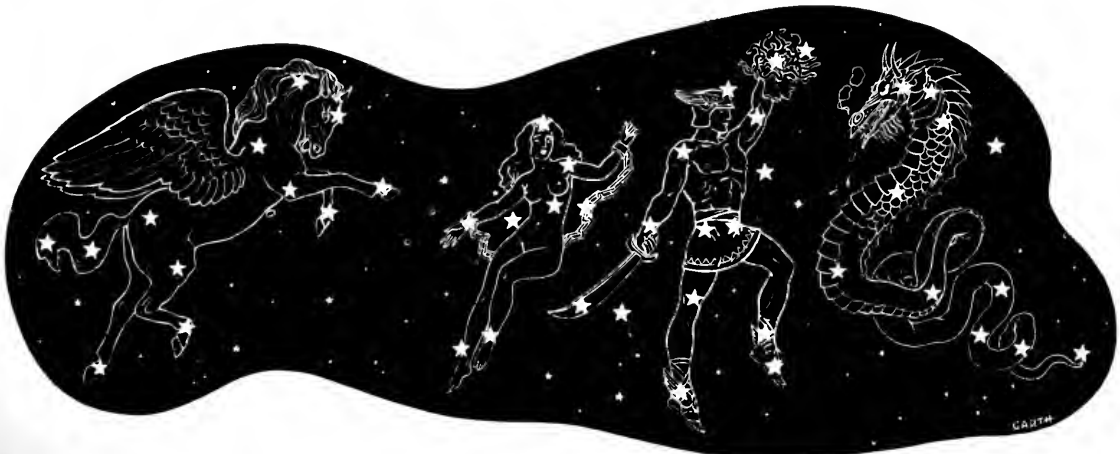



# HOTEL SIR FRANCIS DRAKE STARLIGHT ROOF

By **HARRY S. MOYER**, General Manager

**WALTER M. BALLARD CORP.**, Designers

**THOMAS & MERET**, Architects

**W. ADRIAN**, Engineer

The operations problem, a place of public assembly-bar, restaurant and cocktail lounge on the 21st floor of the Sir Francis Drake, replacing the large penthouse apartment of Louis Lurie, was solved. The doors were opened, drinks were mixed, toasts made and the San Francisco panorama was at your feet. The operations problem was over, and a difficult and interesting one it had been.

Gutting partitions had been simple. The removing and relocating of plumbing, heating, wiring, standpipes, even ice water lines, were easily solved.

A tremendous obstacle had been a large kitchen

duct: a huge affair, 30"x60" welded up of 1/8" thick steel plates. This duct came from the basement kitchen, picking up several other cooking areas en route, and extending through the 21st floor up to a large exhaust fan above. At the 21st floor, its location was architecturally impossible. It had to be re-routed, and being in its existing location, tightly tied in by elevators, exits, flues, etc., we had an exceedingly difficult job of making it twist and turn, dodging all obstacles, but eventually freeing the floor area and nearby wall surface from the critical obstruction and allowing the simple band of glass wall to continue.

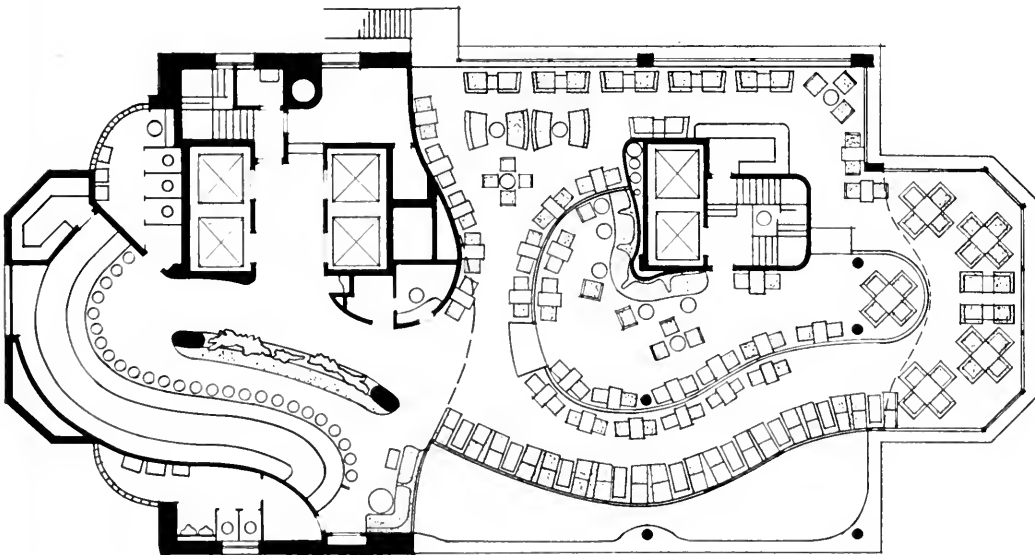

FLOOR PLAN

# STARLITE ROOF . . .

In this same location three small but ugly flues extended up from the sub-basement areas and these too had to become horizontal runs over to a new location when they could proceed upward and retrace their various courses to and through the roof.

And then we had to bring in the view . . . a simple task on a hotel built in the '20s when windows were spots completely surrounded by huge chunks of masonry. Although the masonry was curtain wall construction only, it necessitated a complete scaffolding of 300 linear feet at the 21st and 22nd tiers with all the shoring and demolition

necessary to knock down 5,000 square feet of masonry, disposing of it down a 250 foot elevator to oblivion. The only curtain walls that were allowed to remain were two pieces facing the tall Four Fifty Sutter Building across the street and further away looking up at the Top of the (censored) a worthy competitor's cocktail lounge. In between these two sections of masonry one lone large spot window faced North—focused on the Coit Tower on Telegraph Hill.

The new walls were glass, clear sheets of panes as large as possible, so large that some had to be 1/2" thick, specially drawn 2500 miles away in

**FLOOR PLAN in original form—indicates alterations made in design and construction of the Hotel Sir Francis Drake's new STARLITE ROOF.**

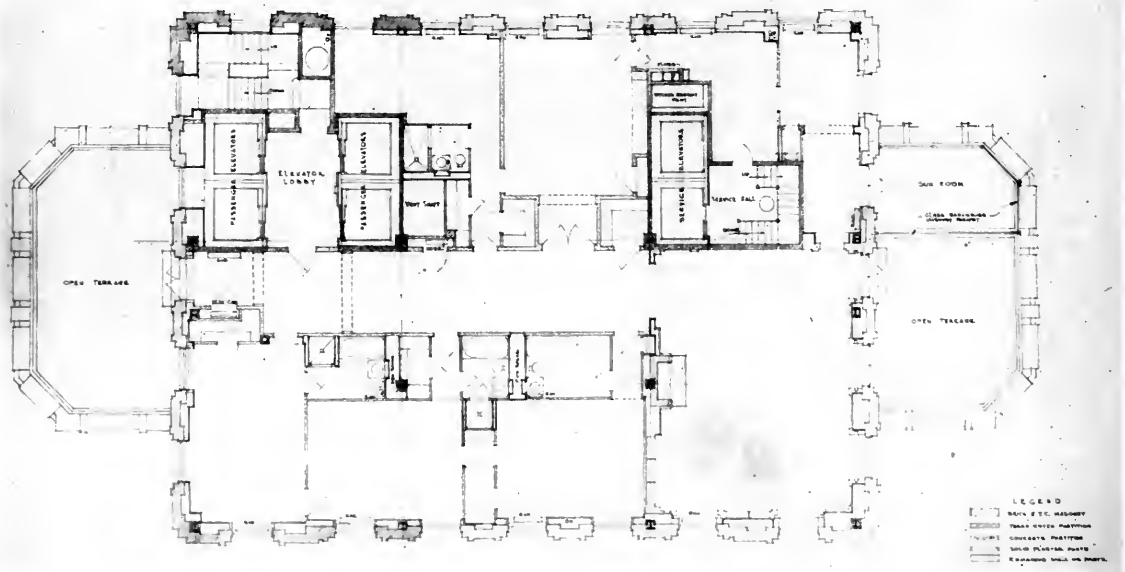

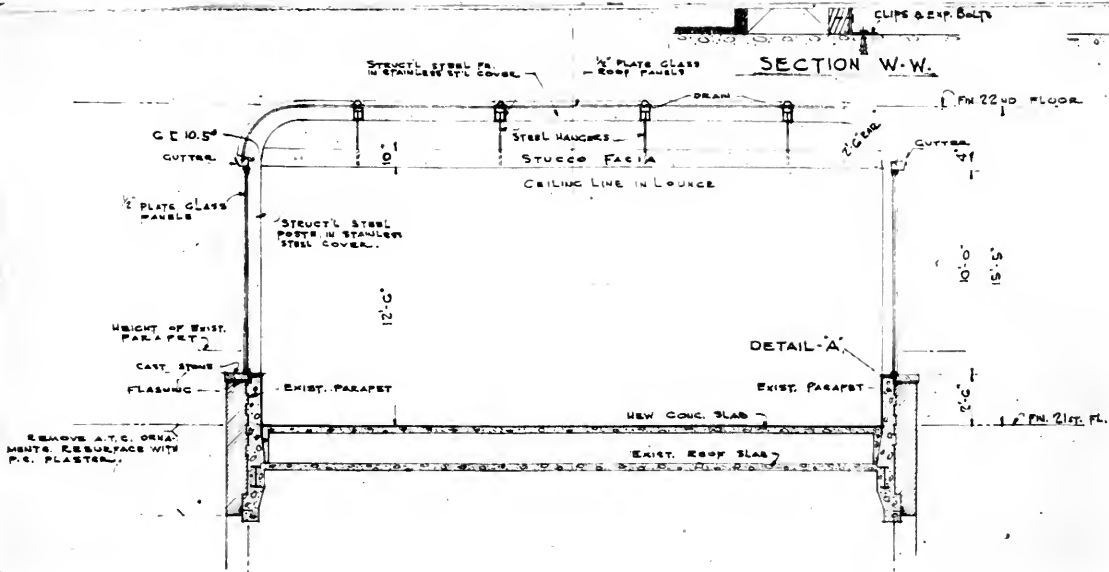

**SECTION of the STARLITE ROOF showing changes in walls, concrete cutting sections and installation of over-head and side glass.**

the Pittsburgh furnaces, crated, shipped and installed with the usual difficulties that were amplified by strikes just when they hurt the most. We were fortunate in being able to order several extra sheets of glass as two were broken in transit, and the entire job would have been jeopardized if we had to wait 90 days for replacements.

The glass stops were designed of small pipe columns with Kawneer moldings welded to them. Due to the height of the installation and the prevailing winds, all stops had to be designed to withstand 20 pounds per square foot lateral pressure and 50 mile gales. Window cleaning problems were overcome by welding safety clasps to

**Hotel Sir Francis Drake STARLITE ROOF**

**Architect:** Thomas & Meret

**Engineer:** W. Adrian

**Designers:** Walter M. Ballard Corp.

**General Contractor:** Barrett & Hilp

**Scaffolding:** Beatty Safway Scaffold, Inc.

**Plastering:** Smith & Daneri

**Tile:** Donlon Tile Co.

**Concrete Cutting:** EMSCO of San Francisco

**Terrazzo:** National Tile & Terrazzo Co.

**Ornamental Iron:** Arnke Iron Works

**Plumbing & Heating:** Macnsons

**Metal Partitions:** Munthe Equipment Co.

**Backlighting & Cocktail Tables:** Boyd Lighting Fixture Co.

**Masonry Work:** Wm. A. Rainey & Son

**Fixtures:** Mangrum, Holbrook & Elkus

**Photographs:** R. Strohmeyer

# STARLITE ROOF . . .



**ABOVE:** Patrons on raised platform center section have an unobstructed view of the hills, city, and San Francisco Bay. At night the scene presents a brilliant spectacle of lights and reflections.

**BELOW:** Back wall paintings by John Garth add a celestial touch to the serpentine bar of the STARLITE ROOF.



**WEST WALL** overhanging section is converted into tiled pool and fountain—illuminated at night with colored lights.



**SAME AREA**



**DURING CONSTRUCTION**



**LOOKING WEST** the city lies like a blanket of stars below—center section is a raised platform.



Illustrating use of scaffolding during STARLITE construction

vertical and horizontal glass stops and including an access glass door at each end so that one window cleaner could circumnavigate the entire band of windows in one operation.

In creating this public space for 200 people, the problem of exits arose and we added an exterior 5'-0" wide stairway designed for the usual 100 pound per square foot load with access to the stair from glass doors equipped with panic bolts. The stairs terminated at the 16th floor roof of the hotel, re-entering a stair tower. This amplified the

two existing interior stairs and provided a total of 11'-6" wide exits which will satisfy all newly proposed hotel exit provisions now being considered by local and state departments having jurisdiction.

Once these structural difficulties were overcome, the decorative problems began. The ceiling height was limited and with a particularly low ceiling over the bar, it was deemed necessary to let the bar provide and reflect light on the ceiling. This was done by creating a long band of glass on the bar top itself, with a double row of neon below.



Another  
**MANGRUM HOLBROOK & ELKUS**  
*Installation*



Drug Department, Andrew Williams Store, Oakland

**Interior Layouts . . . Store Fixtures**

*When in San Francisco we invite you to visit our  
new, enlarged Cabinet Plant*

**MANGRUM HOLBROOK & ELKUS**  
SAN FRANCISCO OAKLAND SACRAMENTO LOS ANGELES

ARCHITECTURAL  
Steel Construction

AND

Plastering

FOR

“Starlite Roof”

HOTEL SIR FRANCIS DRAKE

BY

**SMITH & DANERI**

375 BAYSHORE BLVD.

SAN FRANCISCO



*Reaching  
for the Stars*

WITH

**BEATTY SAFWAY  
SCAFFOLD**

Used in the construction of the  
“Starlite Roof” of San Francisco’s  
Sir Francis Drake Hotel.

RENTALS OR SALES  
FOR EVERY SCAFFOLD PURPOSE

**BEATTY SAFWAY SCAFFOLD, Inc.**

*Manufacturers*

415 BRYANT STREET  
SAN FRANCISCO  
619 27TH STREET  
OAKLAND

**TILE**  
 IN THE  
 Unique Pool  
 AND  
 Beautiful Rest Rooms  
 OF  
 Sir Francis Drake Starlite Roof  
 BY  
**DONLON TILE COMPANY**  
 OF SAN FRANCISCO

**EMSCO**  
 OF  
*San Francisco*

Concrete Cutting  
 for  
 Starlite Roof  
 Hotel Sir Francis Drake

1020 Harrison St. Phone  
 San Francisco HEmlock 5436

**TERRAZZO WORK**  
 FOR THE  
*"Starlite Roof"*  
 Installed by  
 THE  
**NATIONAL TILE  
 AND TERRAZZO CO.**

Phone 198 Mississippi St.  
 UNderhill 0273 San Francisco, California

**Arnke Iron Works**

---

**ORNAMENTAL IRON**  
 for  
**STARLITE ROOF**

780 Brannan St. San Francisco  
 MArket 6336

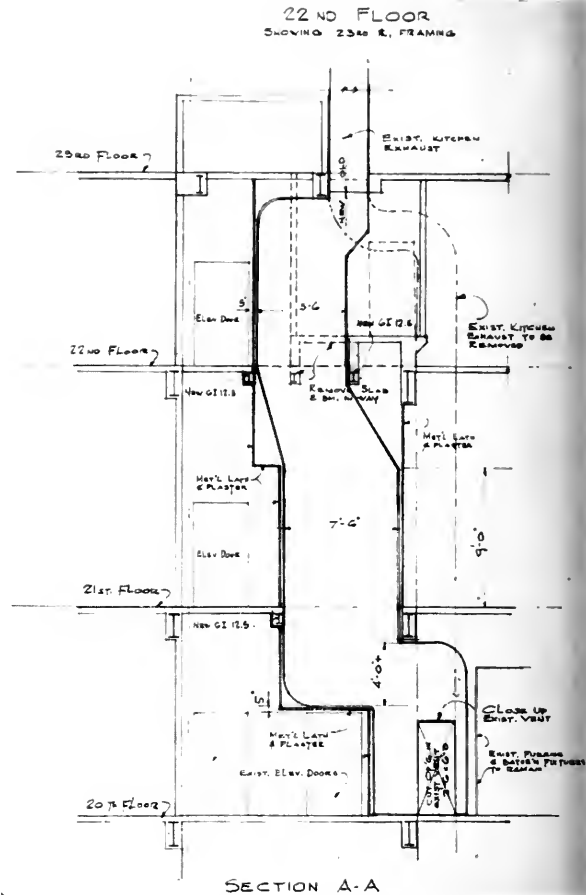

**SECTION:** Showing method of altering vent from the 20th to the 23rd floor.

This was one of the unique features of the construction.

**MACNSONS**

Plumbing, Heating, and Air Conditioning

STARLITE ROOF PLUMBING AND HEATING

---

151 Tehama St. 2301 Palm Ave.  
 San Francisco San Mateo

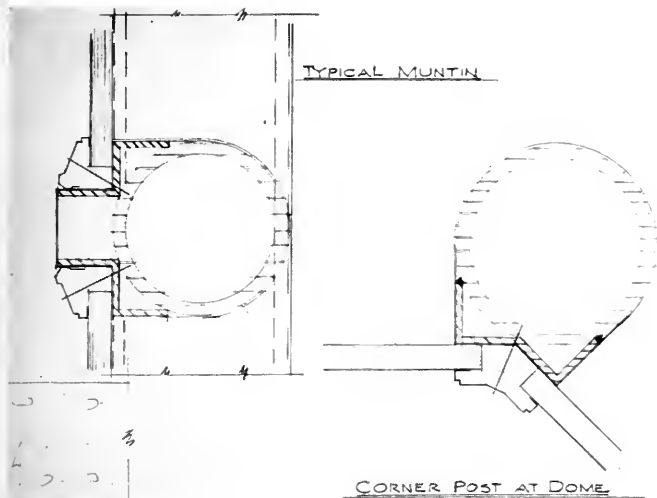

This cast a warm yellow reflection on the ceiling that was emphasized by the back bar treatment of John Garth's murals on a dull matte black surface.

Carpeting, flexwood, lighting, black lights, leather and stainless steel were a necessary part of the design and brought our problem to a conclusion for which conclusion why not read once again our first paragraph?

SHOWN ABOVE are details of a typical muntin and a corner post at the dome. This is also an unusual feature of the STARLITE ROOF design.

### BOYD LIGHTING

BLACKLIGHTING EFFECTS  
and  
NOVELTY COCKTAIL TABLES  
for the  
STARLITE ROOF

Hotel Sir Francis Drake

**Boyd Lighting Fixture Co.**  
56 12TH ST.  
SAN FRANCISCO

### "METAL PARTITIONS FOR EVERY PURPOSE"

For over 25 years

The Starlite Roof Toilet Compartments are "MILLS"

**Munthe Equipment Co.**

7 Front St. EXbrook 5179

Representing

**The Mills Co., Cleveland, O.**

### WM. A. RAINEY & SON

Masonry Work  
& Glass Blocks  
for  
Starlite Roof

323 Clementina St. SUtter 0072

*The New  
Beautiful*

# STARLITE ROOF

Sir Francis Drake Hotel  
San Francisco

## BARRETT & HILP

Building With The West  
For 35 Years

### *Contractors*

San Francisco  
Tel. DOuglas 0700

Los Angeles  
Tel. Long Beach 73583

## PRE-FABRICATION What Is It?

(From Page 18)

However, as has always been the case, critical times call for drastic methods. The recent war, with its stupendous demands for fast production, gave prefabrication the impetus it needed.

Interior equipment, as well as sidewall and roof panels, was prepared for installation at the factory. Architects, engineers and interior equipment experts collaborated and made it possible to assemble these items into compact units ready for delivery to the site by rail or truck.

They were then put in place by the contractor who had been laying the groundwork for their arrival.

The great progress made by the automobile industry since Henry Ford introduced the principles of mass-production has become an American legend.

Ford's ideas were considered revolutionary at the time and the doubters and head-shakers had a field day. But Mr. Ford soon silenced his critics by becoming enormously successful. He put his detractors to rout.

Today the methods he pioneered are being employed in most large industrial undertakings. And

many smaller industries use them to the fullest extent possible.

The building industry must adopt these principles in order to produce the millions of homes needed and do it in the shortest possible time and at the lowest possible cost.

Whatever technical difficulties, or "bugs," exist at present to impede the progress of prefabrication can be eliminated.

All the necessary engineering elements have been developed. But prefabrication manufacturers must order and set up the dies, fixtures, jigs and required tooling. This cannot be done without considerable capital.

More research and experimental work will have to be done. This holds true in all fields of prefabrication, whether of wood, concrete, steel or aluminum.

Scores of plans and blue prints will have to be drawn up and the innumerable details of integration worked out.

The hostility of labor unions as well as the obstacles presented by antiquated building codes must be overcome.

Short-sighted builders and contractors must be educated to the idea that prefabrication, with its lowering of costs, will make for almost unlimited expansion and greater profits in the long run.

Labor must be shown that this greater volume will make for greater stability of employment at high wages.

All concerned will benefit in the traditional American way. The contractor will have his profit, the worker his wage, and the home-buying consumer a better home at lower cost.

Such experimental work as has been undertaken so far indicates that in order to produce homes of any kind on a mass basis it is necessary to have some central point where parts or large sections can be made ready for delivery to the job site.

This means that there is nothing to prevent the home in its entirety being factory-built. In fact, it is the next logical step in the case of certain materials, such as steel and aluminum, and its fabricators are becoming aware of the opportunity.

Certainly a factory is better equipped for making various steel and aluminum shapes, since it has all the necessary tools, dies and fixtures. If not, they can be readily made or procured, and the fabricating of parts undertaken on a large volume basis.

From the foregoing it can be readily concluded that prefabrication and "factory-built" are in fact interchangeable terms as applied to home-building.

Another important factor in favor of maximum work at the factory is the weather. All material, from initial storage of the raw material to the

(See Page 39)

# Real Estate Loans



F. H. A. loans are readily available to aid in the purchase of existing homes or in the construction of new ones. You can buy or build a home and pay for it in small monthly installments like rent. For example, a 20-year loan of \$6000 would cost about \$49.56 per month, including real estate taxes, insurance, principal and interest.

**CROCKER FIRST NATIONAL BANK**  
SAN FRANCISCO • OAKLAND  
*California's Oldest National Bank*  
Member Federal Deposit Insurance Corporation

# A. I. A.

American Institute



# ACTIVITIES

of Architects

**Arizona Chapter:**  
James Macmillan, President; Arthur T. Brown, Secretary, 740 N. Country Club Road, Tucson, Arizona.

**Central Valley of California:**  
Herbert E. Goodpastor, President; Frank V. Mayo, Secretary, 307 Exchange Building, Stockton 2, California.

**Colorado Chapter:**  
Raymond H. Ervin, President; James M. Hunter, Secretary, 2049 Broadway, Boulder, Colorado.

**Montana Chapter:**  
Ralph H. Cushing, President; H. C. Cheever, Secretary, Montana State College, Bozeman, Montana.

**Northern California Chapter:**  
Hervey P. Clark, President; Lester Hurd, Vice-President; Ralph Pollack, Secretary; William C. Ambrose, Treasurer; 605 Market Street, San Francisco.

**Oregon Chapter:**  
Francis Jacobberger, President; J. D. Annand, Secretary, 401 Central Building, Portland 5, Oregon.

**San Diego Chapter (California):**  
H. Louis Bodmer, President; Louis J. Gill, Secretary, 203 Granger Building, San Diego, California.

**Santa Barbara Chapter (California):**  
Roy C. Wilson, President; Miss Lutah M. Riggs, Secretary, 240 Middle Road, Santa Barbara, California.

**CALIFORNIA COUNCIL OF ARCHITECTS**  
Vincent Palmer, President; Andrew Hass, Vice-President; A. C. Martin, Jr., Secretary-Treasurer; 369 Pine St., San Francisco 4.

**Southern California Chapter:**  
Adrian Wilson, President; A. C. Martin, Jr., Vice President; Walter L. Reichardt, Secretary; George E. Gable, Treasurer; Chapter Headquarters, 3757 Wilshire Blvd., Los Angeles 5, California.

**Spokane Chapter (Washington):**  
Noel E. Thomson, President; Kenneth D. Stormont, Secretary, Hutton Building, Spokane, Washington.

**Utah Chapter:**  
George Cannon Young, President; Theodore R. Pope, Secretary, 29 South State Street, Salt Lake City 1, Utah.

**Washington State Chapter:**  
George W. Stoddard, President; Stephen H. Richardson, Secretary, 516 Central Bank Building, Seattle 4, Washington.

**Hawaii Chapter:**  
Kenneth W. Roehrig, President; James Morrison, Secretary, 334 Federal Bldg., Honolulu, T. H.

## SAN FRANCISCO ARCHITECTURAL CLUB

The San Francisco Architectural Club is again offering an architectural seminar, or review, course for those who plan to take the examination of the California State Board of Architectural Examiners this summer.

The seminar will consist of about 15 lectures given by well qualified men of the architectural and engineering professions, and will cover seven divisions of the examination.

Lectures will be given on Tuesday and Thursday evenings. Complete information is available from Robert B. Allen, San Francisco Architectural Club, 666 Mission Street, San Francisco.

## NORTHERN CALIFORNIA CHAPTER A.I.A.

A recent report to members by President Hervey Parke Clark, indicated the Chapter is devoting considerable thought to furthering the practice of architecture in the State of California. Some consideration is being given the suggestion of establishing "affiliate" or "sub-chapters" in order to serve architects who find it difficult to attend one of the existing Chapter meetings.

One solution of the problem is to hold Chapter meetings away from San Francisco, and as an experiment the Chapter held its March 22 meeting at Palo Alto.

Contemplated Chapter discussions include consideration of: U. S. and Local Hospital programs; Rental Housing Opportunities; a clinic on special methods of design and office practice; and out of town speakers.

## WASHINGTON STATE CHAPTER, A.I.A.

Dr. John H. Fountain of the American Medical Association spoke on the background of the AMA at the April meeting, held in the Engineers Club, Seattle.

Tentative approval has been given an amendment to the Chapter By-Laws increasing dues of members and associates. The matter has been submitted to the Institute for action.

It has been suggested that the new Parkway at the University of Washington be named "Carl Gould Parkway" as a memorial to the late Carl F. Gould, F.A.I.A., who was largely instrumental in its design and promotion.

\* \* \*

## TACOMA SOCIETY

Consideration of legislative matters has predominated recent meetings. Efforts to establish a State Architectural Department for the purpose of doing all institutional work have been defeated.

\* \* \*

The A.I.A. Jury has made William J. Bain a Fellow.

The 1947 Convention of the Institute will be held in Grand Rapids, Michigan on April 20-30, and May 1.

## SOUTHERN CALIFORNIA CHAPTER A.I.A.

A vote of the Executive Committee recently reased the experience requirement for Junior Associate Membership to two years.

\* \* \*

William A. Edwards and John Frederic Murphy,  
(See Page 40)

# WITH THE ENGINEERS

Structural Engineers Association of Northern California

William W. Moore, President; John A. Blume, Vice President; Franklin P. Ulrich, Sec.-Treas.; Offices 214 Old Mint Bldg., San Francisco, Phone GARfield 3890. DIRECTORS, Mark Falk, M. V. Pregnoff, and R. D. Dewell.

American Society of Civil Engineers San Francisco Section

Theodore P. Dresser, Jr., President; Leon H. Nishikian and Sidney T. Harding, Vice Presidents; John E. Rinne, Secretary-Treasurer; 225 Bush St., San Francisco 20.

Puget Sound Engineering Council (Washington)

R. E. Kister, A. I. E. E., Chairman; E. R. McMillan, A. S. C. E., Vice Chairman; L. B. Cooper, A. S. M. E., Secretary; A. E. Nicholson, I. E. S., Treasurer; Offices, L. B. Cooper, c/o University of Washington, Seattle 5, Washington.

## AMERICAN SOCIETY FOR METALS PUGET SOUND CHAPTER

The Puget Sound Chapter of the American Society for Metals recently concluded its Annual Educational Course consisting of a series of four lectures on the subject, "What Steel Shall I Use? Where? When? Why?"

Special points covered in the lectures, which were conducted by C. E. Sims and Myron Nestor of the Battelle Memorial Institute of Columbus, Ohio, included (1) Machinability, (2) Fabrication,

(3) Heat treatment, (4) Strength and fatigue, and (5) Comparative cost and adaptability.

The course was open to the public and conducted by the Chapter without cost to those attending.

According to Ralph Winship, Chairman of the Council, the event was very successful and "considerable interest was shown by those attending the programs, because of the wartime stimulated interest in metals."

\* \* \*

DESIGNING WITH MAGNESIUM was the subject of a talk by Dr. John C. McDonald, Assistant Technical Director, Magnesium Division of the Dow Chemical Company. His illustrated presentation dealt with (1) the basic factors governing the use and choice of magnesium, (2) structural design, and (3) detail design.

## STRUCTURAL ENGINEERS ASSOCIATION OF SOUTHERN CALIFORNIA

Guam's proposed \$400,000,000 Harbor project is being tested in Southern California from a scale model constructed in a large hangar near Azusa under the direction of Dr. Warren O. Wagner of the California Institute of Technology. Dr. Wagner described the construction of the hydraulic model, and showed pictures illustrating the various construction phases and tests, to members of the Structural Engineers Association at their monthly meeting held at the Clark Hotel during March.

The model, covering a large hangar floor representing 10 square miles of Guam Harbor, was constructed of accurately-formed concrete segmental blocks from data submitted by the Navy. The harbor model is filled with water and a newly-developed wave machine produces waves to correspond with the size of waves which occur at Guam under typhoon conditions. From data to be computed as a result of these tests, will come recommendations for type and locations of breakwaters, docks and other important naval installations to resist the destructive forces of waves and tides.

The Structural Engineers Association of Southern California went on record as endorsing California Assembly Bill No. 1332 which would adopt portions of the Uniform Building Code to replace portions of the obsolete and unsafe requirements of the State Housing Act. Opposition was voiced to a parallel bill, AB 753, which would amend the State Housing Act in a different way and incorporate retroactive measures. Mr. S. B. Barnes, Chairman of the Building Code Committee, states that the adoption of AB 1332 would bring about more uniformity and simplicity in regulations governing building construction since the Uniform Building Code is now used by more than 250 cities in California.

**FOR BETTER SERVICE**

*Remember that*

**KRAFTILE is**

**WESTERN HEADQUARTERS**

**FOR**

- ▶ GLAZED Structural Wall Units
- ▶ PATIO Tile
- ▶ QUARRY Tile
- ▶ SWIMMING POOL Overflow Gutter
- ▶ ACID Brick
- ▶ ACID-PROOF Jointing Compounds
- ▶ ACID-PROOF Floor and Tank Construction
- ▶ ACID-PROOF Coatings



- ▶ QUONSET Packaged Steel Buildings
- ▶ STRAN-STEEL Framing

For complete information and prompt service, phone or write

**KRAFTILE COMPANY**

NILES, CALIFORNIA NILES 3611

SAN FRANCISCO: 50 Hawthorne Street - DOUGLAS 3780

LOS ANGELES: 316 E. Commercial Street - MUTUAL 2411

On March 19, a special meeting was sponsored by the Structural Engineers Association of Southern California, to which members of the American Society of Civil Engineers and American Society of Testing Materials were invited. The speaker was LaMotte Grover, Welding Engineer of the Air Reduction Sales Corporation, New York City.

#### PUGET SOUND ENGINEERING COUNCIL

The following were elected to serve as officers of the Council for 1947: R. E. Kistler, Chairman; R. E. McMillan, Vice-chairman L. B. Cooper, Secretary, and A. E. Nickerson, Treasurer.

Considerable study and attention is being given various legislative matters pending in the Washington Legislature.

At the last Examination in land surveying and engineering held in Olympia, some 54 men were issued licenses as professional engineers and land surveyors.

\* \* \*

**ANNUAL MEETING:** The annual meeting of the Council was held on March 28th with H. A. Parker, supervising engineer of the Irrigation Division Bureau of Reclamation, Coulee Dam, spoke on "Work in Progress on the Irrigation Project of the Columbia River Basin."

William D. Shannon, Vice President American Society of Civil Engineers, spoke on "Revision of Engineers Registration Law," and Edward C. Dohm, member of the Engineers Registration Board, discussed "Operation of Engineers Registration Act."

#### STRUCTURAL ENGINEERS ASSOCIATION OF NORTHERN CALIFORNIA

The April meeting was devoted to a consideration of the latest developments in "Precast Concrete Construction," its cost, colors, structural uses and tests to determine structural validity of precast slabs. The subject of rigid frame construction was also discussed.

Otto Buehler, Salt Lake City, led the discussion.

\* \* \*

Professional Guidance Committee, Clarence E. Rinne, Chairman, has organized a seminar for State Structural Engineering examinations in the San Francisco High School of Commerce. Meetings began Thursday, March 13, 7 to 9 p.m. and will continue every Thursday until May 1.

The Committee is developing the desirability, ways, and means of establishing closer contact between the Association and Civil Engineering students of local universities.

The Structural Engineering Information Committee, A. V. Saph, Chairman, has prepared a report of activities for his committee which has been adopted by the directors and will be given to the

## Thanks to my builder



### My home has convenient, built-in telephone outlets

By specifying that telephone conduit be installed during construction, little was added to building cost . . . real value was added to the house.



The location of the telephone can be changed or additional telephones added without drilling through the flooring or running wires along baseboards.

The convenience of well-placed telephone outlets will be appreciated for years to come.



Call or dial your local Telephone Business Office. Ask for Architects' and Builders' Service.

### The Pacific Telephone and Telegraph Co.





**...IN PUBLIC BUILDINGS**



**...IN SCHOOLS**



**...IN HOSPITALS**

*...the logical specification*



In office buildings in major cities throughout the country, in the nation's important hospitals, in public and parochial schools from coast to coast . . . and in thousands of industrial plants, too . . . you'll find Halsey Taylor Drinking Fountains the logical installations.

Patented health-promoting, trouble-proof features make them easily the most hygienic fountains you can specify! Get our latest catalog



**THE HALSEY W. TAYLOR CO.**  
WARREN, O.  
West Coast Plant, Redlands, Calif.

*Halsey-Taylor*  
**DRINKING FOUNTAINS**



**FOR MORE CLEAR FLOOR SPACE  
USE AMERICAN TRUSSES!**

Complete engineering services rendered without charge or obligation on these popular truss designs. Used by Builders for over twenty-five years, they are fully approved everywhere.



For full information, write . . .

**AMERICAN ROOF TRUSS COMPANY**  
228 WEST SANTA BARBARA AVENUE  
Los Angeles, California  
ADams 1-4379

members at a later date.

The Consulting Practice Committee, John J. Gould, Chairman, has had several meetings of late and is very busy completing its work on fees and salaries for engineering services.

Structural Engineering Research Committee, R. S. Chew, Chairman, held an interesting evening meeting at which plans were formulated for cooperation of our Association with the San Francisco Chamber of Commerce and the U. S. Coast and Geodetic Survey in an endeavor to obtain more information on earthquake data.

. . . .

**NEW MEMBERS:** The following men have been elected to membership in the Association: Cedric H. Anderson, John T. Jent, Maurice T. Jones, Bruce G. Norfolk, George E. Schuman, and Johannes Skytte.

**AMERICAN SOCIETY OF HEATING  
AND VENTILATING ENGINEERS**

Dr. B. M. Woods, President, announces the Semi-Annual meeting of the Society for 1947 will be held June 2-4 at the Hotel del Coronado, Coronado, California.

The Southern California Chapter will act as host with arrangements under direction of Robert Lowe, Los Angeles, general chairman.

The three day conference will be attended by members from all parts of the United States and Canada, and will consist of three Technical sessions.

**RAY LESTER ALLIN**

Consulting Engineer

Member American Society of Civil Engineers and Structural Engineers Association of Northern California. Graduate of University of California, '13; Consulting Engineer for the City and County of San Francisco, 1923-1939.

Died March 13th at his home, following a heart attack. Survived by his wife, Irma, four daughters and a twin brother, Ray M. Allin of Washington, D. C.

**JOHN WESLEY HYATT AWARD**

The John Wesley Hyatt Award for the advancement of plastics will be presented on April 23 in Detroit, according to an announcement by William T. Cruse, secretary of the awards committee.

The awards committee for this year consist of Metropolitan Museum of Art; Neil O. Broderson, President, Society of the Plastics Industry; Dr. W. Albert Noyes, Jr., President, American Chemical Society; Charles F. Kettering, Vice President, Gen-



eral Motors Corp'n.; Dr. Edward R. Weidlein, Director of the Mellon Institute of Industrial Research; Dr. Gerald Wendt, Director of Science Illustrated; Virgil E. Meharg, Bakelite Corp'n, and Paul D. Zottu, engineer.

Engineers and allied technicians employed by the State of California received salary increases approximating \$420,000 retroactive payments thru recent action of the State Personnel Board.

#### ANNUAL MEETING ASME

The 1947 Annual Meeting of the American Society of Mechanical Engineers has been set for December 1 to 5 in Atlantic City.

#### AVIATION ENGINEERS

The annual Aviation Division conference of the American Society of Mechanical Engineers will be held in Los Angeles, California, May 26 to 29th.

#### CONSTRUCTION EDUCATION

Basic college training in practical aspects of the construction industry, with special emphasis on labor relations, was urged upon educators recently by Harold W. Richardson, speaking before the American Society of Civil Engineers in New York.

Pointing out that normally the construction industry accounts for more than 10 per cent of the nation's economy, Richardson charged many educational institutions with "failing to note the advances in mechanization and thus have ignored the greatest impetus to practical civil engineering in modern times."

While a few civil engineering schools do make an attempt to include construction courses and a few more offer a smattering of subjects somewhat related to the business Richardson declared, "in no case is a really serious effort made to train students for a life construction career."

He concluded by saying that the greatest need is for educated construction men, not skilled mechanics.

#### LESS REGULATION. SAY CONTRACTORS

The Associated General Contractors of America, through their managing director, H. E. Foreman, have expressed themselves as favoring less government regulation of the construction industry as a means of promoting more building of all types, including housing for veterans.

#### NEVADA BANK

A work permit has been granted the First National Bank of Nevada for construction and remodel of their bank building at Sparks, Nevada. The new work will be of reinforced concrete construction.

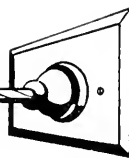

## Full Power to Act

**While planning homes of tomorrow — whether they be new or modernized... be sure to prepare them for your clients' fullest enjoyment of electrical living.**

**Make certain you specify wiring adequate to serve all their needs... so they may connect and operate properly the electrical servants they have now, and the marvelous new ones they are sure to want.**

**Provide that full power in future homes you design by specifying plenty of outlets, switches and circuits, and large enough wire to deliver full power now and in the years to come.**

**Only with adequate wiring will all electrical appliances have FULL POWER TO ACT... efficiently, economically, conveniently.**

### NORTHERN CALIFORNIA ELECTRICAL BUREAU

1355 MARKET STREET  
SAN FRANCISCO 3

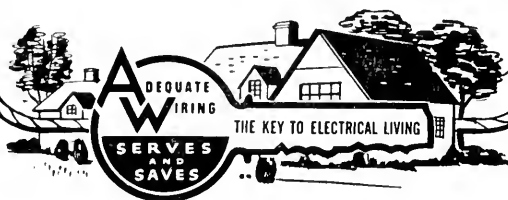



**PRESSURE TREATED LUMBER**  
**● PROTECTS AGAINST DECAY AND TERMITE ATTACK**

*Specify it in your home  
 Available through Lumber Dealers*

LOS ANGELES                      SAN FRANCISCO  
 601 W. 5th Street                333 Montgomery Street  
 Phone Mlchigan 6294            Phone DOuglas 3883

***J. H. Baxter & Co.***

AGENTS FOR WEST COAST WOOD PRESERVING CO. SEATTLE, WASH.



**LOS ANGELES**

*Branch Offices*

HOLLYWOOD	SIERRA MADRE	UPLAND
PASADENA	TEMPLE CITY	LA VERNE
LONG BEACH	WHITTIER	SAN PEDRO
RIVERSIDE	ONTARIO	INDIO

**OAKLAND  
 SAN FRANCISCO**

**HEADLINE NEWS & VIEWS**

**By E. H. W.**

Building material prices used to "Skyrocket" . . . now they are aboard a jet-propelled rocket, you can neither see nor reach them.

\* \* \*

Douglas Whitlock, Chairman, Building Products Institute, does some wishful thinking when he suggests Congress approve funds for training of apprentices in the building trades in order to avert a shortage of skilled workers . . . the AFL and CIO have the answer, not Congress.

\* \* \*

The creation by law of a permanent national management-labor council to make continuing studies of industrial relations, now being advocated by the Committee for Economic Development, is one approach to a problem which America must solve.

\* \* \*

"If labor and materials are available, one million homes can be constructed during 1947. Such a volume of construction is entirely dependent upon the wholehearted and harmonious cooperation of labor, management, finance, and government."—Frank W. Cortright, Executive Vice President, National Association of Home Builders.

\* \* \*

Which should come first—a cut in taxes or reduction of the national debt?

\* \* \*

World Trade Week has been set for May 18-24, with business inventories in 1946 increased more than \$9-billion over 1945, what's holding up international prosperity?

\* \* \*

There are 41,638 licensed contractors in California, according to the California Department of Professional and Vocational Standards.

\* \* \*

"Cleansing of the labor movement of communism will lead to more peaceful labor-management relations" . . . Chamber of Commerce, U. S.

\* \* \*

A postal deficit of \$288 million is in prospect for the 1948 fiscal year, according to Joseph L. Lawler, 3rd Ass't Postmaster General.

\* \* \*

"There is no place in this country for a peacetime housing czar as proposed in the Taft-Ellender-Wagner housing bill,"—Douglas Whitlock, Chairman, Building Products Institute.

\* \* \*

"Adequate housing can be achieved only by government subsidy."—Talbot F. Hamlin, Prof. of Architecture, Columbia University.

ARCHITECT AND ENGINEER

## IN THE NEWS

### HOUSING

The Monterey County (California) Housing Authority received a low bid of \$334,905 from contractor E. M. Carlson, Salinas, for the construction of 197 emergency housing units.

### EXPORT SALES MANAGER

Frank Potts, has been named export sales manager for the Permanente Cement Company with general offices in Oakland.

Potts has been with the Kaiser organization since 1943.

### NAMED MANAGER

The Westinghouse Electric Corp. has announced the appointment of R. A. Neal, Vice President, Pittsburgh, Pa., to the position of general manager of the company's Pacific Coast District operations.

### MEAT PACKING PLANT

A CPA permit has been granted and work is expected to start at once on a new \$333,000 reinforced concrete steel building for Kingan & Co., San Francisco meat packers. L. H. Nishkian is the engineer.

### ROOFING FACTORY

Work has started on a new \$222,000 factory building at San Leandro, California, to house the Lloyd Fry Roofing Company.

### NEW FIRM

A new partnership in the mechanical engineering field under the firm name of Hall & Baldwin has been announced. The firm will have its offices in Oakland.

### DRAWNS PLANS

Martin J. Rist, San Francisco architect, has drawn plans for a \$100,000 addition to the Mary's Help Hospital, San Francisco.

Barrett & Hilp of San Francisco are the general contractors.

### LONG BEACH APARTMENTS

Ernest O. Caldwell, Long Beach engineer, has prepared plans for a 21-unit apartment building to be erected on Wardlow Road, Long Beach, at a total estimated cost of \$118,000.

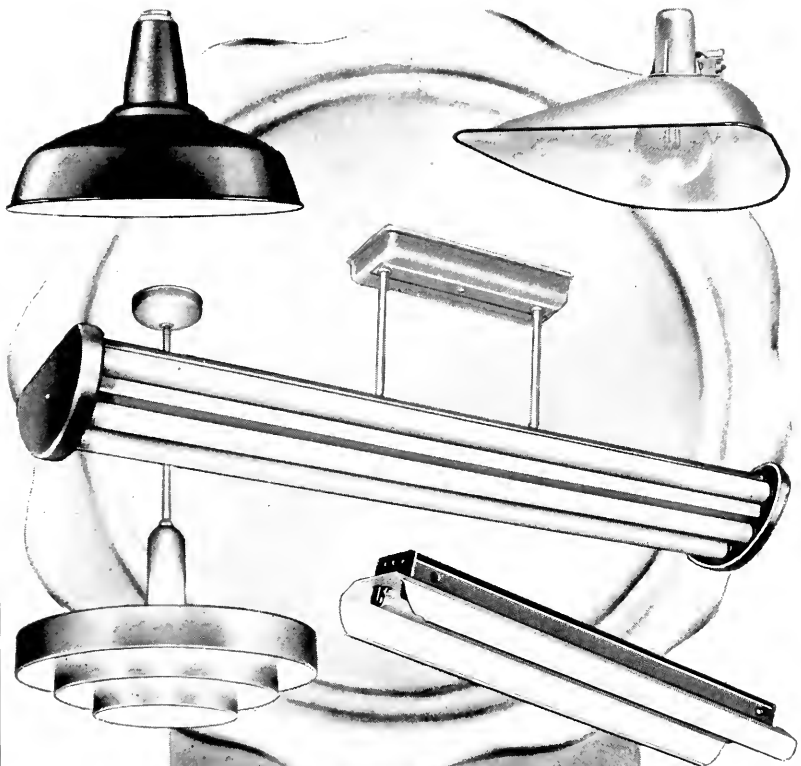

## Certified Quality

Certification is important when you buy lighting equipment. The SMOOT-HOLMAN, RLM and FLEUR-O-LIER approvals are your assurance of maximum lighting efficiency at the lowest maintenance cost.



LOOK FOR THIS LABEL FOR THE FINEST IN  
INCANDESCENT AND FLUORESCENT LIGHTING

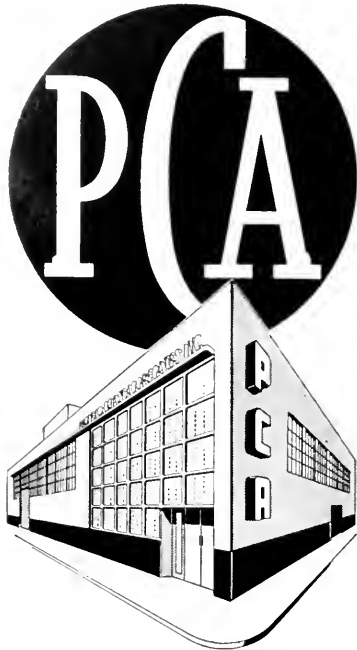

**Announces the Completion of**  
**"HEADQUARTERS FOR QUALITY**  
**BUILDING MATERIALS AT**  
**SENSIBLE PRICES"**

**400 Alabama St. • San Francisco**

We dedicate this handsome, modern building — and 48 other PCA plants, offices and warehouses — to the goal of helping Northern California to meet its critical housing and construction needs.

It is our established PCA policy to manufacture and distribute all types of building materials in the largest possible volume at the smallest possible mark-up. That's why "PCA" is always the symbol of TOP VALUE IN BUILDING MATERIALS.



Contact the nearest PCA office below

**SAN FRANCISCO**  
 400 Alabama Street  
 KLandike 2-1616

**OAKLAND**  
 2400 Peralta Street  
 Hlgate 0770

**FRESNO**  
 414 P Street  
 Ph. 4-3065

**SACRAMENTO**  
 16th and A Streets  
 Ph. 3-6586

**STOCKTON**  
 1020 East Main Street  
 Ph. 8-8643

**SAN JOSE**  
 790 Stockton Ave.  
 Ballard 8670

**IN THE NEWS**

**BRICKS AVAILABLE**

Contractors in the Los Angeles area will be able to secure 35,000,000 new bricks, enough for 15,000 new homes, between now and next spring, H. C. Mathers, president of the Associated Brick Manufacturers of Southern California, declared recently.

**NEW PLANT**

The Campbell Soup Company moves into Western Manufacturing operations for the first time with a \$4,000,000 soup plant at Sacramento, Calif. The plant will cover 130 acres.

**SUB-CONTRACTS AWARDED**

The sub-contracts have been awarded on the \$198,000 Borel Grammar School addition in San Mateo County. The architects are Franklin, Kump & Falk of San Francisco and the general contractor Carrico & Gautier, also of San Francisco.

**BANK ADDITION**

The Santa Monica Commercial and Savings Bank has commissioned architect Sydney Clifton of Los Angeles to prepare plans for a reinforced concrete side addition to its bank building to cost \$125,000.

**GLASS FACTORIES**

General contract bids from a selected list of contractors are being taken by the Owens-Illinois Glass Company for construction of a group of glass factory buildings near Corona, California. Plans were prepared by H. J. Brunier, consulting engineer, of San Francisco.

**NEW CITY HALL**

Plans for a new city hall and police station for the city of Hawthorne, Calif., have been completed by Ralph C. Flewelling and Associates, architects of Los Angeles. Bids will be called for soon.

**COMMUNITY HOSPITAL**

Bonds have been voted for construction of a \$487,000 hospital by the Tulare, California, Hospital District. H. C. Chambers and Myron H. Hunt, Los Angeles, are the Architects.

**GRAMMAR SCHOOL**

Bonds have been voted by the Fowler (Calif.) Elementary School District for the construction of a new grammar school building to cost \$150,000 and consisting of 8 class rooms and a cafeteria. W. D. Coats, Fresno, is the Architect.

**MODESTO (CALIF.)**

Bonds have been voted for the construction of three new grammar schools at Modesto, California. Estimated cost will be \$1,085,000. Fred L. Swartz, Fresno, is the Architect.

**VETERANS MEMORIAL**

Nevada county, California, has employed Architect George C. Selton of Sacramento, to draw plans for remodeling the Veterans Memorial building at Grass Valley, California. Cost is estimated at \$42,000.

**WAREHOUSE**

L. H. Nishkian, structural engineer of San Francisco, is in charge of remodeling the Alchar California Corp'n., plant at San Francisco. Cost \$140,000.

**MT. VIEW SCHOOL**

Bonds have been voted for a new \$240,000 grammar school at Mt. View, California.

**NEW SCHOOLS**

Among school projects under construction in California are: a \$118,000 grammar school addition at Ross; a \$122,000 grammar school near San Jose; \$300,000 addition to the high school at Modesto; and a \$235,000 addition to the Woodrow Wilson grammar school at San Leandro.

**BONDS VOTED**

Voters of Santa Rosa, California have approved financing for the construction of an addition to the high school and grammar school buildings estimated to cost \$750,000.

## PRE-FABRICATION

### What Is It?

(From Page 30)

finished product, can be protected from the elements. Workers are also protected from hampering and time-consuming hazards.

Home construction is now conducted on a more or less seasonable basis, particularly those built by the smaller contractor. He is not as fully equipped as the larger contractor and often not in a position to proceed with work during winter months. Home construction, in many sections of the country, is therefore limited to the portion of the year when weather conditions are favorable.

In factory-built homes, work can proceed without interruption throughout the year. More units can be produced, lowering overhead costs per unit and making possible an additional price reduction to the consumer.

Considerable progress has been made by various fabricating manufacturers in the housing field since the end of the war. Some have gone to extremes, while others have kept to sound fundamentals in their design. To these manufacturers will probably go the lion's share of the credit when the final blueprints have been drawn.

Care must be taken that fly-by-night operators do not enter the field at this critical juncture. This would cause considerable damage to the prefabricated home industry and untold heartbreak and expense to those unfortunate buyers who fell into their clutches.

### Light-Gage Steel

Considerable research and development has already been undertaken on light-gage steel in various types of structures by the Pittsburgh Testing Laboratories, at Pittsburgh, Pa.

Buildings were selected from different sections of the country for making these tests in order to get the necessary cross-section of weather conditions as they affect buildings.

It was found that the light-gage steel members, used for floor and roof construction and those members which were concealed, were practically intact when they were opened for inspection.

In some instances, the original coat of paint was still on. Where rust actually showed, it was apparent that the condition had existed when the steel was originally installed.

Some of these buildings had been up for as long as 40 years.

In figuring the cost of a prefabricated steel or aluminum home, it was found that they compared favorably with ordinary wood construction. There is less depreciation on a steel or aluminum home.

It is also more flexible, more easily erected, dismantled and re-erected in another location, if found necessary or desirable. It is almost 100% salvageable.

## Concrete

Then there is the concrete prefabricated home. Wooden forms were used at first, later replaced by metal forms which were brought to the job site in prefabricated sections. This saved time, labor and money because the forms could be used over and over again.

Contractors either had the metal forms made or rented them for a nominal fee.

Entire sections of prefabricated concrete, side-walls, roofs and floors have been made at the factory, delivered by truck and installed by the contractor.

The principal objection to concrete is that it requires special equipment because of its weight.

(See Page 43)

# SISALKRAFT

REG. U. S. PAT. OFF.

*"More than a building paper"*

**THE SISALKRAFT CO.**

205 West Wacker Drive  
Chicago, Ill.

55 New Montgomery Street  
San Francisco, Calif.

## FORDERER CORNICE WORKS

Manufacturers of

Hollow Metal Products • Interior Metal Trim  
Elevator Fronts and Cabs  
Metal Plaster Accessories • Sanitary Metal Base  
Flat and Roll Metal Screens  
Metal Cabinets • Commercial Refrigerators

**269 POTRERO AVE.**

**SAN FRANCISCO, CALIF.**

**HEMLOCK 4100**

## STRUCTURAL STEEL

For Class A Buildings,  
Bridges, etc.

**JUDSON PACIFIC - MURPHY CORP.**

1200 SEVENTEENTH STREET  
SAN FRANCISCO

==== Plants: San Francisco - Oakland ====

## A.I.A. ACTIVITIES

(From Page 31)

architects; Russell W. Bell, building and loan executive; Wallace C. Penfield, planning engineer; and John M. Gamble, famed painter, have been named members of an Architectural Board of Review for the city of Santa Barbara.

Under regulations of an ordinance establishing the board, applications for building permits in the C-1 zone, together with plans and elevations, will be submitted in triplicate. The Board will submit a written report on the character of the exterior architectural design, and if they approve, the city inspector may then authorize issuance of the permit.

In event the Board recommends changes in architectural design which the applicant refuses to make, a public hearing is to be held before issuance of the permit.

The Board has 15 days in which to act after receipt of original application.

Reconsideration is being given to the proposal of establishing a Student Chapter at U.S.C. The vote thus far is predominately in favor of such a Chapter.

Walter R. Hagedohm has been appointed chairman of the Committee on Public Relations. He is being assisted by George Allison, Paul Hunter, Walter Reichardt and John Rex.

E. Warren Hoak, has been appointed by the South Pasadena City Council to membership on the city's first planning commission.

Llewellyn Parker, will represent the Structural Engineers at future Chapter meetings.

The Exhibit Committee will furnish an exhibit in the Citizens National Bank booth at the coming Home Owners Show.

## CALIFORNIA ARCHITECT BOARD

Herbert J. Powell, A.I.A. of Los Angeles, and William Clement Ambrose, A.I.A. of San Francisco, were reappointed to the California State Board of Architectural Examiners by Governor Earl Warren.

The new terms are for a period of extending to January 15, 1951.

## ARCHITECTURAL COMPETITION

The Homestead (Pa.) District Chamber of Commerce has announced a competition for the redesign of a Homestead business block to be conducted in the Department of Architecture, Carnegie Institute of Technology.

Cash awards in the amount of \$500 will be given winners.

Students will investigate existing store uses and make suggestions for functional rearrangements better suited to modern merchandising techniques.

## PLANNING HOSPITALS

Trends and techniques of planning modern hospitals and clinics were discussed by some 75 hospital administrators, consultants, doctors, and architects at a conference on Hospital Planning recently held at the University of Michigan.

The program, under direction of Dean Wells I. Bennett of the University's College of Architecture and Design, included discussions on the Veterans Hospital Program, Planning of a Veterans Hospital, Community Hospitals, and Functional Design in Hospital Architecture.

Consideration was given to buildings of 200 beds and less.

## ENGINEERS STUDY TRAFFIC

Traffic congestion, called "the nation's number one urban planning problem," was analyzed clinically by the 2000 leading civil engineers who attended the recent annual meeting of the American Society of Civil Engineers.

The findings of the society's City Planning Division, which conducted a recent survey of cities in the United States and Canada with populations of 100,000 or more, were used as a basis for the clinic. Reports will soon be made public.

# VALUABLE NEWS SERVICE

- BUILDING MATERIAL DEALERS
- CONTRACTORS
- ENGINEERS
- FINANCIAL INSTITUTIONS

**ARCHITECTS REPORTS** gives advance news on construction projects in Northern California, lists: name of projects, location, architect, proposed cost and other pertinent information.

**HANDY** individual slip-reports, issued daily at a total cost of only

\$10 a month

# ARCHITECT'S REPORTS

Published Daily

The ARCHITECT and ENGINEER, Inc.

68 Post Street, San Francisco - DO 8311

# ESTIMATOR'S GUIDE

## BUILDING AND CONSTRUCTION MATERIALS

PRICES GIVEN ARE FIGURING PRICES AND ARE MADE UP FROM AVERAGE QUOTATIONS FURNISHED BY MATERIAL HOUSES TO SAN FRANCISCO CONTRACTORS. 2½% SALES TAX ON ALL MATERIALS BUT NOT LABOR

All prices and wages quoted are for San Francisco and the Bay District. There may be slight fluctuation of prices in the interior and southern part of the state. Freight cartage, at least, must be added in figuring country work.

**BONDS**—Performance—\$10 per \$1000 of contract. Labor and materials, \$10 per \$1000 of contract.

**BRICKWORK**—

Common Brick—Per 1M laid—\$80.00 to \$100.00 (according to class of work).  
 Face Brick—Per 1M laid—\$150 to \$200 (according to class of work).  
 Brick Steps—\$2.30 per lin. ft.  
 Brick Veneer on Frame Bldg.—Approx. \$1.50 per sq. ft.  
 Common Brick—\$26.00 per M, truckload lots, f.o.b. job.  
 Face Brick—\$60 to \$100 per M, truckload lots, delivered.  
 Cartage—Approx. \$5.00 per M.

**BUILDING PAPER**—

1 ply per 1000 ft. roll.....	\$5.30
2 ply per 1000 ft. roll.....	7.80
3 ply per 1000 ft. roll.....	9.70
Brownskin, Standard, 500 ft. roll.....	7.00

**BUILDING HARDWARE**—

Sash cord com. No. 7..... \$2.50 per 100 ft.  
 Sash cord com. No. 8..... 2.75 per 100 ft.  
 Sash cord spot No. 7..... 3.50 per 100 ft.  
 Sash cord spot No. 8..... 3.75 per 100 ft.  
 Sash weights, cast iron, \$50.00 ton.  
 Nails, \$3.42 base.  
 Sash weights, \$45.00 per ton.

**CONCRETE AGGREGATES**—

The following prices net to Contractors unless otherwise shown. Carload lots only.

	Bunker per ton	Del'd per ton
Gravel, all sizes.....	\$2.44	\$2.15
Top Sand.....	2.38	3.13
Concrete Mix.....	2.38	3.06
Crushed Rock, ¼" to ¾".....	2.38	2.94

	Bunker per ton	Del'd per ton
Crushed Rock, ¾" to 1½".....	\$2.38	\$3.13
Roofing Gravel.....	2.81	3.50
River Sand.....	2.50	3.06

**Sand**—  
 Lapis (Nos. 2 & 4)..... 3.56 3.94  
 Olympia (Nos. 1 & 2)..... 3.56 3.88

**Cement**—  
 Common (all brands, paper sacks), carload lots, \$3.02 per bbl. f.o.b. car; delivered \$3.40.  
 Cash discount on carload lots, 10c a bbl., 10th Prox., less than carload lots \$4.00 per bbl. f.o.b. warehouse or delivered.  
 Cash discount 2% on L.C.L.

Atlas White	} 1 to 100 sacks, \$3.13 sack warehouse or del.; \$9.56 bbl. carload lots.
Calaveras White	
Medusa White	

**DAMP-PROOFING and Waterproofing**—

Two-coat work, \$5.00 per square.  
 Membrane waterproofing—4 layers of saturated felt, \$9.00 per square.  
 Hot coating work, \$3.00 per square.  
 Medusa Waterproofing, \$3.50 per lb. San Francisco Warehouse.  
 Tricocel waterproofing.  
 (See representative.)

**ELECTRIC WIRING**—\$15 to \$20 per outlet for conduit work (including switches).

Knob and tube average \$6.00 per outlet. (Available only for priority work.)

**ELEVATORS**—

Prices vary according to capacity, speed and type. Consult elevator companies. Average cost of installing a slow speed automatic passenger elevator in small four story apartment building, including entrance doors, about \$8000.00.

**EXCAVATION**—

Sand, \$1.00; clay or shale, \$1.50 per yard. Trucks, \$30 to \$45 per day.  
 Above figures are an average without water. Steam shovel work in large quantities, less; hard material, such as rock, will run considerably more.

**FIRE ESCAPES**—

Ten-foot galvanized iron balcony, with stairs, \$250 installed on new buildings; \$300 on old buildings.

**FLOORS**—

Composition Floors, such as Magnesite, 50c per square foot.  
 Linoflor—2 gages—\$3.00 per sq. yd.  
 Mastipave—\$1.50 per sq. yd.  
 Battleship Linoleum—available to Army and Navy only—1/8"—\$3.50 sq. yd. 3/16"—\$3.50 sq. yd.  
 Terazzo Floors—\$1.50 per sq. ft.  
 Terazzo Steps—\$2.50 per lin. ft.  
 Mastic Wear Coat—according to type—20c to 35c.

**Hardwood Flooring**—

Standard Mill grades not available.  
 Victory Oak—T & G  
 3½ x 2¼"..... \$252.00 per M. plus Cartage  
 ½ x 2"..... \$210.00  
 ½ x 1½"..... 200.00  
 Prefinished Standard & Better Oak Flooring  
 3½ x 3¼"..... \$265.00 per M. plus Cartage  
 ½ x 2½"..... 237.00 per M. plus Cartage  
 Maple Flooring  
 3½ T & G Glass..... \$330.00 per M. plus Ctg.  
 2nd 305.00 per M. plus Ctg.  
 3rd 255.00 per M. plus Ctg.  
 Floor Layers' Wage, \$1.87½ per hr. (Legal as of Jan. 21, 1946. Given us by Inlaid Floor Co.)

**GLASS**—

Single Strength Window Glass.... \$ .40 per □ ft.  
 Double Strength Window Glass... .60 per □ ft.  
 Plate Glass, under 75 sq. ft..... 1.25 per □ ft.  
 Polished Wire Plate Glass..... 2.10 per □ ft.  
 Rgh. Wire Glass..... .60 per □ ft.  
 Obscure Glass..... .40 per □ ft.  
 Glazing of above is additional.  
 Glass Blocks..... \$2.75 per □ ft. set in place

**HEATING**—

Average, \$2.50 to \$3.00 per sq. ft. of radiation, according to conditions.  
 Warm air (gravity) average \$64 per register.  
 Forced air average \$91 per register.

**INSULATION AND WALLBOARD—**

2" Insulation—Full thickness	\$65.00 per M sq. ft.
3 1/2" Insulation—Full thickness	\$95.50 per M sq. ft.
Aluminum Insulation—Foil-mounted on both sides	\$33.50 per M sq. ft.
Tireboard—4'x6' panel	\$9.00 per panel
Wall Board—2" thickness	\$49.50 per M sq. ft.
Finished Plank	\$69.00 per M sq. ft.
Ceiling Tireboard	\$69.00 per M sq. ft.

**IRON**—Cost of ornamental iron, cast iron, etc., depends on designs.

**LUMBER—**

No. 1 Common	\$90.00 per M
No. 2 Common	88.00 per M
Select O. P. Common	94.00 per M

Flooring— Per M Delvd.

V.G.-D.F. B & Btr. 1 x 4 T & G Flooring	\$170.00
"C" and better—all	170.00
"D" and better—all	170.00

Rwd. Rustic—"A" grade, medium dry..... 150.00  
8 to 24 ft.

"B" grade, medium dry.....	150.00
Plywood .....	15c to 18c per ft.
Plyscord .....	9/2c per ft.
Plywall .....	9c per ft.
Plyform .....	15c per ft.

Shingles (Rwd. not available)—

Red Cedar No. 1—\$13.00 per square; No. 2, \$10.50; No. 3, \$9.00.  
Average cost to lay shingles, \$6.00 per square.  
Cedar Shakes—Tapered: 1/2" to 3/4" x 25"—\$17.00 per square.  
Resawn: 3/4" to 1 1/4" x 25"—\$22.00 per square  
Average cost to lay shakes,— 8.00 per square

**MILLWORK—Standard.**

D. F. \$140 per 1000. R. W. Rustic \$150 per 1000 (delivered).  
Double hung box window frames, average with trim, \$10 and up, each.  
Complete door unit, \$14 to \$20.  
Screen doors, \$6.00 to \$8.00 each.  
Patent screen windows, 50c a sq. ft.  
Cases for kitchen pantries seven ft. high, per lineal ft., \$12.00 each.  
Dining room cases, \$12.00 per lineal foot.  
Rough and finish about \$1.00 per sq. ft.  
Labor—Rough carpentry, warehouse heavy framing (average), \$60.00 per M.  
For smaller work average, \$60.00 to \$75.00 per 1000.

**MARBLE**—(See Dealers)

**PAINTING—**

Two-coat work .....	per yard 60c
Three-coat work .....	per yard 80c
Cold water painting .....	per yard 25c
Whitewashing .....	per yard 15c

**PAINTS—**

Two-coat work .....	60c per sq. yd.
Three-coat work .....	80c per sq. yd.
Cold water painting .....	25c per sq. yd.
Whitewashing .....	15c per sq. yd.
Turpentine.....	\$1.85 per gal. in 5-gal. cont.
Raw Linseed Oil.....	\$3.19 per gal. in 5-gal. cont.

Boiled Linseed Oil.....	\$2.50 per gal. in drums
Boiled Linseed Oil—	\$2.90 per gal. in 5-gal. containers.
Replacement Oil—	\$2.56 per gal. in drums, \$2.56 per gal. in 5-gal. containers.
Use Replacement Oil.....	\$2.69 per gal. in 1 gal. cont.
A deposit of \$7.50 required on all drums.	

**PATENT CHIMNEYS—**

6-inch .....	\$2.00 lineal foot
8-inch .....	2.50 lineal foot
10-inch .....	3.50 lineal foot
12-inch .....	4.50 lineal foot

**PLASTER—**

Neat wall, per ton delivered in S. F. in paper bags, \$17.60.

**PLASTERING (Interior)—**

3 Coats, metal lath and plaster.....	Yard \$3.00
Keene cement on metal lath.....	3.50
Ceilings with 3/4 hot roll channels metal lath (lath only) .....	3.00
Ceilings with 3/4 hot roll channels metal lath plastered .....	4.50
Single partition 3/4 channel lath 1 side (lath only) .....	3.00
Single partition 3/4 channel lath 2 inches thick plastered .....	8.00
4-inch double partition 3/4 channel lath 2 sides (lath only).....	5.75
4-inch double partition 3/4 channel lath 2 sides plastered .....	8.75
Thermax single partition; 1" channels; 2 1/4" overall partition width. Plastered both sides .....	7.50
Thermax double partition; 1" channels; 4 3/4" overall partition width. Plastered both sides .....	11.00
3 Coats over 1" Thermax nailed to one side wood studs or joists.....	4.50
3 Coats over 1" Thermax suspended to one side wood studs with spring sound isolation clip .....	5.00
Note—Channel lath controlled by limitation orders.	

**PLASTERING (Exterior)—**

2 coats cement finish, brick or concrete wall .....	Yard \$2.50
3 coats cement finish, No. 18 gauge wire mesh .....	3.50
Lime—	\$4.00 per bbl. at yard.
Processed LLime—	\$4.15 per bbl. at yard.
Rock or Grip Lath—	3/8"—30c per sq. yd.
5/8"—	29c per sq. yd.
Composition Stucco—	\$4.00 sq. yard (applied).

**PLUMBING—**

From \$150.00 per fixture up, according to grade, quality and runs.

**ROOFING—**

"Standard" tar and gravel, 4 ply—\$11.00 per sq. for 30 sqs. or over.  
Less than 30 sqs. \$14.00 per sq.  
Tile \$40.00 to \$50.00 per square.  
Redwood Shingles, \$15.00 per square in place.  
5/2 #1-16" Cedar Shingles, 4 1/2" Exposure .....\$16.50 square

5/8 x 16"—#1 Cedar Shingles, 5" Exposure .....	\$17.00 square
4/2 #1-24" Royal Shingles, 7 1/2" Exposure .....	\$18.25 square
Re-coat with Gravel	\$5.50 per sq.
Asbestos Shingles \$30 to \$60 per sq. laid.	
1/2 x 25" Resawn Cedar Shakes, 10" Exposure .....	\$18.50
3/4 x 25" Resawn Cedar Shakes, 10" Exposure .....	21.00
1 x 25" Resawn Cedar Shakes, 10" Exposure .....	22.00
Above prices are for shakes in place.	

**SHEET METAL—**

Windows—Metal, \$2.50 a sq. ft.  
Fire doors (average), including hardware \$2.80 per sq. ft.

**SKYLIGHTS—(not glazed)**

Copper, \$1.25 sq. ft. (flat).  
Galvanized iron, 65c sq. ft. (flat).  
Vented hip skylights 90c sq. ft.

**STEEL—STRUCTURAL—**

Base, delivered, \$3.06 per 100, plus normal extras; or \$300.00 to \$400.00 ton in place. Light truss work higher.

**STEEL REINFORCING—**

\$200.00 ton, set.

**STORE FRONTS** (None available).

**TILE—**

Ceramic Tile Floors—\$1.50 per sq. ft.  
Cove Base—\$1.25 per lin. ft.  
Glazed Tile Wainscot—\$1.50 per sq. ft.  
Asphalt Tile Floor 1/8" x 3/8"—\$ .40 per sq. ft. Light shades slightly higher.  
Cork Tile—\$1.00 per sq. ft.  
Mosaic Floors—See dealers.  
Lino-Tile—\$1.00 per sq. ft.

**Wall Tile—**

Glazed Terra Cotta Wall Units (single faced) laid in place—approximate prices:  
2 x 6 x 12..... \$1.25 sq. ft.  
4 x 6 x 12..... 1.50 sq. ft.  
2 x 8 x 16..... 1.45 sq. ft.  
4 x 8 x 16..... 1.75 sq. ft.

**VENETIAN BLINDS—**

60c per square foot and up. Installation extra.

**WINDOWS—STEEL—**

50c per square foot, \$5 for ventilators.



# PRE-FABRICATION What Is It?

(From Page 39)

Freight cost is also a handicap, more or less restricting shipping distance to a limited radius.

For these reasons, it is considered unlikely that concrete will be as widely used as other materials in prefabrication. Its merits are counter-balanced by the fact that producers will be confined to a rather small area of operation.

Some experts are convinced that the house of tomorrow will be of completely prefabricated steel or aluminum and will be ordered through a dealer or distributor who will stock them in warehouses.

They feel that the steel and aluminum types, being vermin-proof, highly fire-resistant, portable and requiring a minimum of repairs and maintenance, are superior to wood and will replace it. This despite the higher initial cost.

However, the plywood manufacturers have something to say about this. Such advances have been made in the plywood industry that, although wood remains as the basic raw material, an en-

tirely new material has been created through the genius of chemistry. A new material that will compete with all other materials every inch of the way.

Progress in the prefabrication industry has fortunately been accelerated because of the vital need for housing. The public has become prefabrication-minded.

It is not to be assumed, however, that the factory-built or prefabricated home, will entirely replace the made-to-order home for those who desire larger or more individually-designed homes. The prefabricating manufacturer is interested only in the average-size or small home because of the volume production made possible by the larger market.

And this is the type of home that will be in greatest demand for the next 10 or 15 years.

The race is to the swift, the battle to the strong, and the home-buyer will get a better house for his money.

## SACRAMENTO HOMES

Work will start soon on 52 homes in Sacramento to cost \$6000 each, N. L. Schutt of Sacramento, owner and builder.

## BUILDING TRADES WAGE (JOB SITES) NORTHERN AND CENTRAL CALIFORNIA

ATTENTION: The following are the PREVAILING hourly rates of compensation as determined by the Wage Adjustment Board, or which have been determined by the United States Department of Labor—Revised to July 1, 1946. Wage scales shown are those being paid and in effect mostly by agreement between employees and their union.

CRAFT	San Francisco	Alameda and Contra Costa	Marin	Vallejo	San Mateo	San Jose	Stockton	Sacramento	Fresno
ASBESTOS WORKERS.....	1.75	1.75	1.75	1.75	1.75	1.75	1.75	1.75	1.75
BRICKLAYERS.....	2.05	2.05	2.05	2.05	2.05	2.05	1.75	2.05	2.00
BRICKLAYERS, HODCARRIERS.....	1.57½	1.57½	1.57½	1.57½	1.57½	1.57½	1.47½	1.15	1.25
CARPENTERS.....	1.75	1.75	1.75	1.75	1.75	1.62½	1.50	1.50	1.50
CEMENT FINISHERS.....	1.75	1.75	1.75	1.75	1.75	1.75	1.75	1.75	1.75
ELECTRICIANS.....	1.87½	1.87½	1.87½	1.70	1.87½	1.87½	1.75	1.82½	1.75
ENGINEERS: MATERIAL HOIST.....	1.60	1.60	1.60	1.60	1.60	1.60	1.60	1.60	1.60
PILE DRIVER.....	2.00	2.00	2.00	2.00	2.00	2.00	2.00	2.00	2.00
STRUCTURAL STEEL.....	2.00	2.00	2.00	2.00	2.00	2.00	2.00	2.00	2.00
GLASS WORKERS.....	1.58½	1.58½	1.58½	1.58½	1.58½	1.21	1.40	1.37½	1.37½
IRONWORKERS: ORNAMENTAL.....	1.85	1.85	1.85	1.85	1.85	1.85	1.85	1.85	1.85
REINF. RODMEN.....	1.75	1.75	1.75	1.75	1.75	1.75	1.75	1.75	1.75
STRUCTURAL.....	2.00	2.00	2.00	2.00	2.00	2.00	2.00	2.00	2.00
LABORERS: BUILDING & CONCRETE.....	1.25	1.25	1.15	1.15	1.15	1.15	1.25	1.25	1.15
LATHERS.....	1.90	1.90	1.60	1.87½	1.75	2.00	1.87½	1.60	1.87½
MARBLE SETTERS.....	1.75	1.75	1.75	1.75	1.75	1.75	1.75	1.75	1.75
MOSAIC & TERRAZZO.....	1.75	1.75	1.75	1.75	1.75	1.75	1.60	1.16	1.12½
PAINTERS.....	1.75	1.75	1.75	1.64	1.75	1.75	1.60	1.60	1.50
PILEDRIVERS.....	1.86	1.86	1.86	1.86	1.86	1.86	1.86	1.86	1.86
PLASTERERS.....	2.00	2.00	1.75	2.00	2.05	2.00	2.00	1.87½	1.87½
PLASTERERS' HODCARRIERS.....	1.75	1.75	1.75	1.75	1.75	1.75	1.65	1.65	1.65
PLUMBERS.....	1.87½	1.87½	1.87½	1.87½	1.87½	1.87½	1.87½	1.87½	1.87½
ROOFERS.....	1.50	1.62½	1.50	1.62½	1.25	1.37½	1.50	1.50	1.50
SHEET METAL WORKERS.....	1.75	1.75	1.75	1.75	1.75	1.75	1.75	1.75	1.75
SPRINKLER FITTERS.....	1.58	1.58	1.58	1.58	1.58	1.58	1.58	1.58	1.58
STEAMFITTERS.....	1.87½	1.87½	1.87½	1.87½	1.87½	1.87½	1.87½	1.87½	1.87½
STONESETTERS (MASON'S).....	2.05	2.05	2.05	2.05	2.05	2.05	1.75	2.05	2.00
TILESETTERS.....	1.80	1.75	1.75	1.75	1.75	1.75	1.37½	1.37½	1.37½

Prepared and compiled by

CENTRAL CALIFORNIA CHAPTER, ASSOCIATED GENERAL CONTRACTORS OF AMERICA

with the assistance and cooperation of secretaries of General Contractors Associations and Builders Exchanges of Northern California.

# CLASSIFIED ADVERTISING

RATE: 10c PER WORD . . . CASH WITH ORDER

MINIMUM \$2.50

**ARCHITECT'S REPORTS**—A valuable advance news service giving building and construction information daily on projects in Northern California. Name, location, architect, proposed cost, etc., on individual slips. Deal for securing new business leads. Hundreds of items, total monthly cost only \$10. Don't delay, subscribe today. ARCHITECT ENGINEER, Room 618, 68 Post Street, San Francisco, California. Phone DOugles 311.

**POWER HOIST**, double spool, Briggs & Stratton engine, reduction gear, 24 to 1, two friction clutches, two spline clutches, two brakes. Capacity 1500 lbs., 100 feet per minute. Complete, compact unit, 4 feet square, weighs 500 lbs. Only \$250.00 plus sales tax f.o.b. Stockton, Calif. PHILLIPS FORWARDING CO., 109 So. Van Buren St., Stockton, Calif., Ph. 34654.

**METAL WINDOWS** (Steel-Aluminum-Bronze). Large Stock, ALL TYPES. STEEL SASH SALES & SERVICE, Weehawken, N. J.

**ENGRAVING**—Good engravings are essential to a satisfactory job of printing reproduction. For the best, see Poor Richard Photo Engraving Co., 324 Commercial St., San Francisco.

## NEWS & COMMENT ON ART

(From Page 6)

April 19; and Wednesday afternoon from 2:00 to 4:00, beginning April 23. The course is designed to help one see more sharply, consciously and appreciatively through a study of the fundamentals of drawing and painting. The series is of ten weekly classes consisting in lecture and demonstration and in experiment by class members in the basic devices of art. The course is specifically for those who, though interested in art, think they "can't draw a straight line." Classes are free of charge, and materials are provided.

A continuation course for those who have com-

pleted the beginning course in PAINTING FOR PLEASURE will also be given twice: Saturday afternoons from 2:00 to 4:00 beginning April 19, and Tuesday afternoons from 2:00 to 4:00 beginning April 22.

**ART CLASSES FOR CHILDREN:** Conducted by Miriam Lindstrom.

**INTERMEDIATE CLASS IN DRAWING,** Saturday afternoons, 2.00 to 4.00. This is a class for young people from 10 to 15 years old who are seriously interested in art. The course is free of charge, and materials are provided.

**CHILDREN'S CLASS** Saturday mornings, 10:30 to 11:30. This is a class in drawing, painting and clay modeling for children from 5 to 10 years old. Free of charge.

### HOGAN LUMBER CO.

*Wholesale and Retail*

### LUMBER

**MILL WORK • SASH & DOORS**

*Office, Mill, Yard and Docks*

**SECOND AND ALICE STREETS • OAKLAND, CALIF.**

*Telephone GLencourt 6861*

### CLINTON CONSTRUCTION CO. OF CALIFORNIA

### General Contractors

**923 FOLSOM STREET • SAN FRANCISCO**

**SUtter 3440**

### SANTA MARIA INN

### SANTA MARIA, CALIFORNIA

FRANK J. MCCOY, General Manager

FERNAND E. PIMENTEL, Manager

On the  
Coast  
Highway  
between  
San  
Francisco  
and  
Los  
Angeles



American  
or  
European  
Plan  
•  
Old  
English  
Tap  
Room

### KATE NEAL KINLEY MEMORIAL FELLOWSHIP

The Board of Trustees of the University of Illinois have announced the sixteenth annual consideration of candidates for the Kate Neal Kinley Memorial Fellowship, established in 1931.

The Fellowship yields the sum of \$1000 to be used in defraying the expenses of a year's advanced study of the Fine Arts in America or abroad.

It is open to graduates of the College of Fine and Applied Arts in Music, Art and Architecture (Design or History). Applicants should not exceed 24 years of age.

Full details may be secured from Rexford Newcomb, Chairman of the Kate Neal Kinley Memorial Fellowship Committee, Urbana, Illinois.

### WEST COAST MANAGER

S. H. Harrison, formerly manager of machinery electrification for the Westinghouse Electric Corporation, Pacific Coast District, was recently appointed Pacific Coast manager of that company's Industrial Division, with headquarters in San Francisco.

A native of Tacoma, Washington, Harrison went with Westinghouse first as a graduate student at East Pittsburgh, Pa., was later transferred to Seattle, Washington, as a salesman for the industrial division. He became machinery electrification manager in 1940, and served in that capacity until his recent appointment.

### THOMAS G. HOFMANN

Thomas G. Hofmann of San Francisco, who started his hardware career in 1900 with the Baker & Hamilton Company and later became sales representative of P. & F. Corbin, makers of builders hardware, passed away recently in Los Angeles. He was a native of San Francisco.

ARCHITECT AND ENGINEER

# BOOK REVIEWS

## PAMPHLETS AND CATALOGUES

**PRINCIPLES AND PRACTICE OF SURVEYING, Volume 11—"Higher Surveying" (Sixth Edition),** by Chas. B. Breed and George L. Hosmer. John Wiley & Sons, Inc., Publishers, 440 Fourth Ave., New York 16. Price \$4.50.

This is the sixth edition of "Higher Surveying," by Charles B. Breed and the late George L. Hosmer and comprises Volume 11 of PRINCIPLES AND PRACTICE OF SURVEYING. "Higher Surveying" was first published in 1908. Since then, with its companion volume, "Elementary Surveying," it has come to be generally recognized as one of the outstanding works on surveying in the English language. Professor Breed has made certain important revisions. Part III (Photogrammetric Surveying) has been extended and rearranged so as to produce a well organized section on present day methods of surveying from the air. Chapters on Triangulation and Astronomy have been brought up to date to conform with present practice. Many illustrations have been revised, particularly in Parts I and III and new problems at the ends of chapters have been introduced.

\* \* \*

**ARCHITECTURE—An Art For All Men.** By Talbot F. Hamlin, Prof. of Architecture, Columbia University. Columbia University Press, N. Y. Price \$3.50.

The intense postwar interest in building gives this book a particularly timely appeal in a highly readable style and is well illustrated. Based upon the fact that architecture is an art with which everyone comes in daily contact, the Author gives the reader an introduction to the whole subject of architecture; its various forms of construction, planning, relation between function and design, form, materials, decorative elements, structure and ornament, and style.

### FRUIT PLANT

The CPA has granted a permit for construction of a fruit packing plant and precooling and cold storage building at Kelseyville, California. Estimated to cost \$400,000, plans are by Donnell E. Jaekle, architect of San Jose.

### NAMED REPRESENTATIVE

J. S. Ponten, Oakland, California, and the Pacific Building Materials Company of Portland, Oregon, have been named West Coast representatives of the SERVICISED PRODUCTS CORPORATION of Chicago, manufacturers of "Para-Plastic" a hot poured rubber seal waterproofing.

The Most Complete Line of  
**STEELS and BUILDING MATERIALS**  
Made by a Single Producer



See Sweet's Catalog File or write us for full information.

**REPUBLIC STEEL CORPORATION**  
GENERAL OFFICES: CLEVELAND, OHIO

DENVER, COLORADO . . . . . CONTINENTAL OIL BUILDING  
LOS ANGELES, CALIFORNIA . . . . . EDISON BUILDING  
SALT LAKE CITY, UTAH . . . . . WALKER BANK BUILDING  
SAN FRANCISCO, CALIFORNIA . . . . . RIALTO BUILDING  
SEATTLE, WASH. . . . . WHITE-HENRY-STUART BUILDING

## PACIFIC MANUFACTURING CO.

HIGH CLASS INTERIOR FINISH  
QUALITY MILLWORK

142 SANSOME ST., SAN FRANCISCO  
Garfield 7755

6820 MCKINLEY AVE., LOS ANGELES  
THornwall 4196

BUILDERS EXCHANGE, OAKLAND

## "AMERICAN - MARSH"

CONDENSATION UNIT

Pumping  
Machinery  
for  
Every  
Purpose

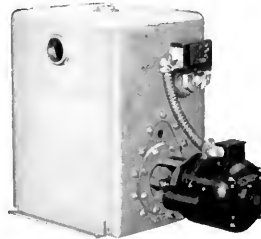

For Service  
Call  
DOuglas  
6794  
or  
MUtual 8322

**SIMONDS MACHINERY CO.**  
SAN FRANCISCO 816 FOLSOM  
LOS ANGELES 455 EAST 4TH

## VERMONT MARBLE COMPANY

Producers and Finishers  
of  
Domestic and Imported Marbles

525 MARKET STREET, SAN FRANCISCO  
Phone Suffer 6747  
3522 COUNCIL STREET  
(Beverly Blvd. at Virgil Ave.)  
LOS ANGELES 4, CALIF.  
Telephone Fairfax 7834



# IN THE NEWS

## CABLE CAR CABLES

Inventor of the cable car, A. S. Hallidie, built what was probably the first steel plant in the West—the Washburn and Noen Company wire rope plant in San Francisco. He built it because it was the only way he could obtain the wire cables to propel his cars.

The plant now belongs to the American Steel & Wire Company, still manufactures wire cables for San Francisco's cable railways.

## TRACY SCHOOL

Bonds have been voted and drawings completed for an 8-class room, assembly, cafeteria, and kindergarten addition to the grammar school at Tracy, California. Elmore G. Ernst, Stockton, is the architect. Cost will be \$200,000.

## JET PROPELLED DISHWASHER

Production of the new Henry J. Kaiser jet-propelled aluminum dishwasher has reached 12,000 units per month, according to Paul L. Yager, general sales manager of Kaiser Fleetwings, Inc., Oakland, California.

Four models range in price from \$127 to \$200. Cabinet and chassis models, standard or de luxe, can be installed in any present kitchen or sink.

## BARRETT & HILP

Announcement has been made that the contracting firm of Barrett & Hilp, which has been conducting a general contracting business as a partnership, has been incorporated.

No change in name or management was involved in the incorporation, company officials report.

## RESIGNS

Donald M. Bufkin, southern California representative of the California Redwood Association since

1939, has resigned to become associated with the firm of Wallace & McGuire, distributors of Wood Mosaic Parkay floors.

## DISSOLVES PARTNERSHIP

John Ekin Dinwiddie, A.I.A., Architect, formerly associated with Eric Mendelsohn and Albert H. Hill, recently announced the opening of offices in San Francisco, California for the practice of architecture.

## INDUSTRIAL EXPANSION

The Industrial Department of the San Francisco Chamber of Commerce reports that forty-nine new northern California plants costing \$2,378,500 and twenty-nine expansions of existing plants to cost \$2,358,500 were announced for February.

## NEW WAREHOUSE

A CPA permit has been granted for the construction of a new office and warehouse building in Emeryville, California, at a cost of \$490,000. H. J. Brunner, San Francisco, Structural Engineer; Louis C. Dunn, general contractor.

## GOVERNMENT HOSPITALS

Douglas D. Stone and Lou Mulloy, San Francisco architects have completed preliminary drawings for an addition to the U. S. Marine Hospital in San Francisco to cost \$2,500,000; while Stolte, Inc., general contractors have been awarded work on foundations of the Base Hospital building for the U. S. Army at Fairfield, California, a project which will cost \$3,000,000 when completed.

## TAKING BIDS

The Alturas, Calif., elementary school district is taking bids for the building of a new grammar school building expected to cost \$180,000. Plans include 4 classrooms, a kitchen, auditorium, nurses room and music room, and construction will be of reinforced concrete and frame. Leonard F. Starks of San Francisco is the architect.

## MONTEREY HOUSING

The Monterey County Housing Authority is taking bids on the general contract for the construction of 197 emergency housing units at a total estimated cost of \$350,000. Charles E. Butner of Sausalito is the architect.

Plans for the removal of one of the University of California's three cyclotrons to the Los Angeles campus are well under way.

## *Check those accidents!*

Minimize possible damage claims against building owners  
by installing —

**Finlenite Non-Slip Metal Safety Treads**

Standard sizes or made to specification  
CHECKERED, FLUTED, OR PLAIN SURFACES

**GUNN CARLE & CO**  
20 POTRERO AVENUE • SAN FRANCISCO, CALIF.

## METAL WINDOWS

Steel—Aluminum—Bronze

Large Stock—ALL TYPES

Steel Sash Sales & Service

Weehawken, N. J.

## IN THE NEWS

### NAMED SALES MANAGER

W. J. Gleason has been named export sales manager for the Iron and Steel Division of Kaiser Company, Inc.

### CHEMICAL FACTORY

The Dewey & Almy Chemical Company have been granted a CPA permit for the construction of a \$280,000 addition to their San Leandro, California plant. Christensen & Lyons have the general contract.

### WESTERN CORK

The Western Crown Cork & Seal Company have been granted a CPA permit for the construction of an \$850,000 factory and office building in South San Francisco. Albert F. Roller, San Francisco, architect, is preparing drawings.

### DRIED FRUIT

The California Prune & Apricot Growers Association have been granted a CPA permit for the construction of a \$409,000 dried fruit processing plant at San Jose, California. Plans being prepared by the Austin Co.

### MACARONI FACTORY

A \$75,000 factory is being built by the Frenso (California) Macaroni Manufacturing Company under a recent CPA permit.

### PATENTS ISSUED

The U. S. Patent Office has issued 2,500,000 patents since it was established 154 years ago.

### PARISH

Permit has been granted St. Joseph's Catholic Church, Marysville, California, for construction of a parish hall building to cost \$55,000. Harry J. Devine, Sacramento, is the Architect.

### UNION STATION

James H. L'Hommedieu, president of the Oakland Chamber of Commerce will appoint a special committee of Oakland business and professional men whose duties will be to speed up construction of a new Union Station for Oakland.

### GLASS PLANT

Site of a proposed \$3,000,000 fiberglass plant at Santa Clara has been acquired by the Owens-Corning Fiberglass Corp. The building when completed will contain 500,000 sq. ft. of space.

## DINWIDDIE CONSTRUCTION COMPANY

•  
**BUILDERS**  
•

CROCKER BUILDING  
SAN FRANCISCO

## MULLEN MFG. COMPANY

BANK, STORE AND OFFICE  
FIXTURES—CABINET WORK  
OF GUARANTEED QUALITY  
CHURCH SEATING

Office and Factory:  
60-80 RAUSCH ST., Bet. 7th and 8th Sts.  
San Francisco  
Telephone UNDERhill 5815

## THE TORMEY COMPANY

GENERAL PAINTERS  
AND DECORATORS

Phone UNDERhill 1913

563 FULTON STREET  
San Francisco



## HERRICK IRON WORKS

STRUCTURAL STEEL  
REINFORCING STEEL

18TH AND CAMPBELL STS.  
OAKLAND, CALIF.  
Phone GLencourt 1767

Phone GARfield 1164

## Thomas B. Hunter

Consulting Engineer

DESIGNER OF HEATING  
AIR CONDITIONING  
VENTILATING AND WIRING  
SYSTEMS. MECHANICAL  
AND ELECTRICAL EQUIP-  
MENT OF BUILDINGS

41 SUTTER STREET  
ROOM 710  
San Francisco California

## Scott Company

HEATING . . PLUMBING . . TILE



243 MINNA STREET  
SAN FRANCISCO  
Phone EXbrook 6741

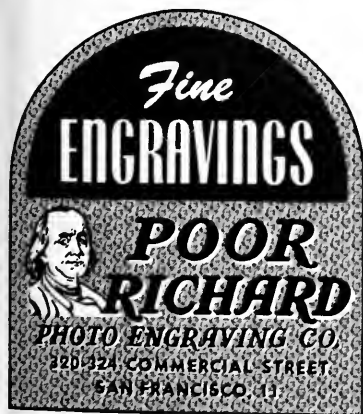

**PITTSBURGH  
TESTING LABORATORY**

Successors to  
SMITH, EMERY & COMPANY

*Testing and Inspecting  
Engineers and Chemists*

Structural Materials, Structures  
Equipment, Pipe, Soils.

651 Howard St., San Francisco 5  
EXbrook 1747

**A. F. MATTOCK CO.**

*Builders*



212 CLARA STREET  
SAN FRANCISCO

**INDEPENDENT  
IRON WORKS**

Steel Buildings  
Service Stations  
Steel Storage Tanks  
Fabricated Plate Work  
Steel & Sheet Metal Products  
Fabricated Structural Steel  
Steel Distributors

**Eighth & Pine Sts. Oakland, 7**

**George F. Brayer**

**ELECTRICAL  
CONTRACTOR**

**166 Seventh Street  
San Francisco**

Phone: MArket 1761

**Index to Advertisers**

ALADDIN Heating Corp.	48
AMERICAN Roof Truss Co.	34
ARCHITECTS Reports	40
ARNKE Iron Works	28
BARRETT & Hilp, Contractors	29
BASALT Rock Company Back Cover	
BAXTER & Company, J. H.	36
BEATTY Safway Scaffold, Inc.	27
BOYD Lighting Fixture Co.	29
BRAYER, Geo. F.	48
CLASSIFIED Advertising	43
CLINTON Construction Company	44
CROCKER First National Bank	30
DINWIDDIE Construction Company	47
DONLON Tile Co.	28
EMSCO of San Francisco	28
FORDERER Cornice Works	39
FULLER, W. P. Co.	*
GUNN, Carle & Company	46
HANKS, Inc., Abbot A.	48
HAWS Drinking Faucet Company	2
HERRICK Iron Works	47
HOGAN Lumber Company	44
HUNT, Robert W., Company	48
HUNTER, Thos. B.	47
INDEPENDENT Iron Works	48
JUDSON, Pacific-Murphy Corp.	39
KRAFTILE Company	32
MACNSONS, Plumbing	28
MANGRUM, Holbrook & Elkus	27
MATTOCK, A. F.	48
MICHEL & Pfeffer Iron Works	
Inside Back Cover	
MULLEN Mfg. Co.	47
MUELLER Brass Co.	*
MUNTHE Equipment Co.	29
NATIONAL Tile & Terrazzo Co.	28
NORTHERN California Electrical Bureau	35
PACIFIC Coast Aggregates, Inc.	38
PACIFIC Coast Gas Association	
Inside Front Cover	
PACIFIC Manufacturing Company	45
PACIFIC Portland Cement Company	*
PACIFIC Telephone & Telegraph Co.	33
PITTSBURGH Testing Laboratory	48
POOR RICHARD Engraving	47
PORTLAND Cement Association	*
RAINEY, Wm. A., & Son	29
REMILLARD-Dandini Co.	48
REPUBLIC Steel Corporation	45
SANTA Maria Inn	44
SCOTT Co.	47
SIMONDS Machinery Company	45
SISALKRAFT Company	39
SMITH & Daneri	27
SMOOT-Holman Co.	37
STANLEY Works, The	*
STEEL Sash Sales & Service	47
TAYLOR Co., Halsey W.	34
TORMEY Company, The	47
U. S. BONDS	1
VERMONT Marble Company	45
WESTERN Asbestos Company	*
WOOD, E. K., Lumber Company	36

\*Indicates Alternate Months

**ABBOT A. HANKS, INC.  
Engineers & Chemists**

INSPECTING — TESTING — CONSULTING  
CONCRETE • STEEL • MATERIALS  
CHEMICAL AND TESTING  
LABORATORIES  
• RESEARCH AND INVESTIGATION •

TESTS OF STRUCTURAL MATERIALS  
DESIGN OF CONCRETE MIXES  
SHOP AND ERECTION INSPECTION OF  
STRUCTURES AND EQUIPMENT  
INVESTIGATION OF STRUCTURES  
AND MATERIALS  
TESTS AND INVESTIGATION OF  
FOUNDATION SOILS  
FIRE RESISTANCE AND INSULATION  
TESTS

624 Sacramento Street, San Francisco

**Robert W. Hunt Company  
ENGINEERS**

Inspection • Tests • Consultation  
Schools and Other Structures  
Are Built as Designed

*When Construction Materials are  
Inspected at point of Manufacture  
and during Erection by*

**ROBERT W. HUNT COMPANY**

*Cement, Concrete, Chemical, Metallurgical,  
X-Ray and Physical Laboratories*

Chicago - New York - Pittsburgh  
Los Angeles - All Large Cities  
San Francisco, 251 Kearny Street

**REMILLARD-DANDINI Co.**

**Brick and  
Masonry Products**



400 MONTGOMERY STREET  
SAN FRANCISCO, CALIF.

**A L A D D I N  
Heating Corp.**

Specializing in  
QUALITY HEATING  
EQUIPMENT

2222 San Pablo Avenue  
OAKLAND  
TWinoaks 1022

# ARCHITECT AND ENGINEER

COMPLETE STORE MODERNIZATION

San Francisco



MAY

1947

# DEPENDABLE



**A  
"PACIFIC  
PRODUCT"**

*Produced by*  
**PACIFIC PORTLAND  
CEMENT COMPANY**  
San Francisco • Los Angeles  
Portland

*Sold by*  
**YOUR BUILDING  
MATERIALS DEALER**

# UNIFORM - TIME TESTED



# • ARCHITECT

Vol. 169

No. 2

# AND ENGINEER

ARCHITECTS' REPORTS—Published Daily  
Telephone DOuglas 8311

E. H. WILDER  
Editor

MARK DANIELS, A.I.A.  
Associate Editor

JOHN S. BOLLES, A.I.A.  
Book Reviews

MICHAEL GOODMAN  
Post-War Planning

L. H. NISHKIAN  
Consulting Editor

E. N. KIERULFF\*  
Ass't Editor  
\*In the Service

## ★ Contents for

# MAY

COVER PICTURE: "DESIGN FOR SELLING"—Rucker-Fuller—Page 12

EDITORIAL NOTES . . . . .	4
NEWS AND COMMENT ON ART . . . . .	8
DESIGN FOR SELLING, RUCKER-FULLER CO. By EUGENE BURNS . . . . .	12
CALISTOGA, CALIFORNIA, MOTEL By JAMES H. GARROTT, Architect . . . . .	16
THE ROBERT S. ATKINS STORE MODERNIZATION By DONALD BEACH KIRBY, A.I.A. . . . .	18
IN THE NEWS . . . . .	26, 37, 47
A.I.A. ACTIVITIES . . . . .	31
WITH THE ENGINEERS . . . . .	32
HEADLINE NEWS & VIEWS By E. H. W. . . . .	36
ESTIMATOR'S GUIDE, Building and Construction Materials . . . . .	41
BUILDING TRADES WAGE SCALES, Northern and Central California . . . . .	43
WOOD FIBER, INSULATION BOARD . . . . .	43
BOOK REVIEWS, Pamphlets and Catalogues . . . . .	45
CLASSIFIED ADVERTISING . . . . .	43

ARCHITECT AND ENGINEER (Established 1905) is published on the 15th of the month by The Architect and Engineer, Inc., 68 Post St., San Francisco 4; Telephone EXbrook 7182. President, K. P. Kierulff; Vice-President and Manager, L. B. Penhorwood; Treasurer, E. N. Kierulff.

Los Angeles Office: Wentworth F. Green, 6605 Hollywood Blvd., Los Angeles 28, Telephone HEmpstead 3171.

Entered as second class matter, November 2, 1905, at the Post Office in San Francisco, California, under the Act of March 3, 1879. Subscriptions United States and Pan America, \$3.00 a year; \$5.00 two years; foreign countries \$5.00 a year; single copy 50c. ARCHITECTS' REPORTS are published daily from this office, Vernon S. Yallop, Manager.



# EDITORIAL NOTES

## EARLY TRAINING

Ernest Pickering, A.I.A., The University of Cincinnati, Department of Architecture, in an article in ARCHITECTURE a Profession and a Career, writes:

"Tradition has it that in former times, on an appointed day, a Chinese baby had placed before him several significant objects. If he picked up something symbolic of writing, such as a brush, he was destined to become a scholar; if he chose a piece of money, he was to be trained as a merchant.

"American youths do not select a career for themselves at such an early age, but their decisions are often just as lacking in vocational guidance and analytical judgment . . .

"The reasons most often given for studying architecture are: 'I took a course in drafting,' 'I am interested in houses,' or 'My father is a builder.' . . . "In order to discuss pre-professional training, it is necessary to take a brief glance at professional education. In a school of architecture, candidates for a degree must develop three abilities: The ability to analyze—to understand; The ability to work with the hands—to draw; and The ability to create beauty and order—to design . . . Thus he need not bring to college any unusual prerequisites—only an alert and disciplined mind.

"Unfortunately for the prospective architectural student, modern high schools are now suffering from growing pains . . . The high school student is often pushed beyond the limits of his mental maturity. He attempts to do professional work in commercial art, life drawing, interior decoration, and architectural drafting and design. He skims off the cream of his creative milk supply and having skimmed it knows not what to do with it.

"Instead of ambitious programs in drawing and creative design, prospective students of architecture should be given simple exercises to develop some skill and considerable appreciation, together with elementary discussions, by those qualified to speak, concerning the nature of architecture as one of the basic need of mankind. The student would thus come to his professional work with an open and uninhibited mind.

## CALIFORNIA ARCHITECTS LAUNCH LEGISLATIVE PROGRAM

Until completion of the organization of the California Council of Architects, and the various local Chapters, into a closely woven association of Architects, the profession suffered in numerous ways because of its inability to present a united

front in local, state, and national matters relating directly, and indirectly, to the Architectural profession.

Formation of the California Council and its affiliation with similar groups throughout the Nation to form a greater American Institute of Architects, now places the individual Architect in a position of being strongly represented in all matters pertaining to the profession.

Leadership in the California Council of Architects is to be commended for its initial venture into the "cooperative representation field" by approaching the professions legislative problems thru the vehicle of "public education."

Few legislators have a desire to "attack" any of the recognized professions such as, Architecture, Engineering, Medicine, or Law. They do, however, have definite need of factual material pertaining to enactment of laws which may in their overall application have a bearing upon one or all of these professions.

Therefore, a constructive program of educational cooperation by the Architectural profession, thru a central organization truly representative of the Architects, will result in tremendous benefit, not only from a legislative standpoint, but also from the standpoint of a better public understanding of the Architects position in meeting today's needs for better living.

\* \* \*

## BUILDING CODES

Our attention was called to a situation wherein a recently adopted Building Code contained such rigid regulations relating to electrical installations in new and reconstruction projects the electrical contractors of the area were forced to add a 10 per cent charge on all electrical work.

This ten per cent charge, as one contractor explained it, "is to take care of the expense we are put to when the city building inspector inspects the job and requires much of the work redone."

We think this is a good argument for support of Uniform Building Codes wherein certain standards are set forth and when met the work is accepted.

Even under a Standard Uniform Building Code, there is probably need for use of "good judgment" by building inspectors, as well as strict adherence to the Code.

\* \* \*

Schools and governmental construction continue to top the list of construction projects under way throughout the Pacific Coast.



## This car is running with an **"EMPTY"** gas tank!



Even after the gas gauge says "empty" a modern car can keep going for a good many miles. Here's why.

Automobile manufacturers know human nature. They figure that, sooner or later, we'll get careless, or misjudge how far we have to go. So the gas gauge is set to show "empty," while there are still a couple of gallons left in the tank.

**This reserve supply** is a swell idea that has kept many a family from getting stuck.

It's an even better idea for a family's budget!

*A reserve supply of dollars* is a lifesaver in case of financial emergency. It will keep your family going if sudden illness strikes, or unexpected expenses show up.

And one of the easiest ways to build just such a cash re-

serve is *buying U. S. Savings Bonds on the Payroll Savings Plan!*

**Millions of Americans** have discovered that *automatic Bond buying* is the quickest, surest way of piling up an emergency fund. And of saving money for other things, too —important things like college for the kids, or a home in the country, or a cash income for later in life.

What's more, the money you save in Bonds buckles right down and starts *making more money*—in just 10 years you get back \$100 for every \$75 you put in today.

**So keep on buying Bonds** on the Payroll Plan. Buy all the extra Bonds you can, at any bank or post office. And remember, you're helping your country as well as yourself —for every Bond you buy plays a part in keeping the U. S. strong and economically sound!

## Save the easy way..buy your bonds through payroll savings

*Contributed by this magazine  
in co-operation with the Magazine Publishers of America as a public service.*



# Simpson

QUALITY SINCE 1895

— ANNOUNCES the creation and manufacture of a superior, sound-absorbing acoustical tile—manufactured in the West and allocated for Western building.

## ACOUSTICAL TILE

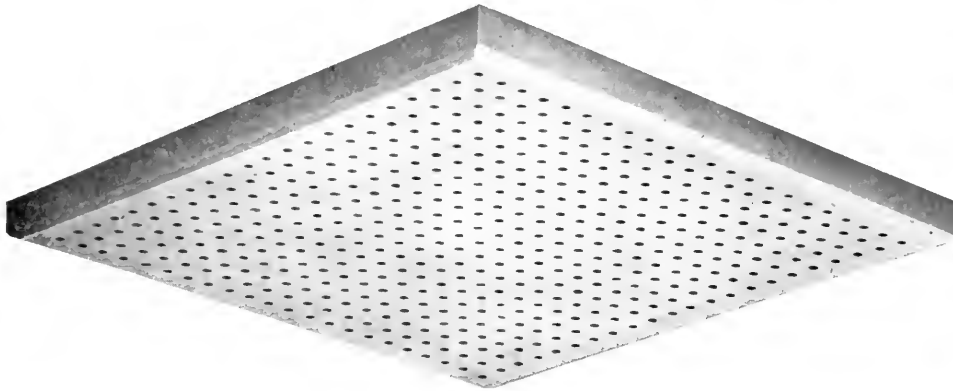

Extensive tests have proven that under special processing the long, tough fibers of Douglas fir produce material which possesses extremely high sound-absorbing qualities. For this reason, Simpson technicians have selected these fibers in creating the new Simpson Acoustical Tile.

1. **Perforations clean-drilled.** Into each square tile are drilled 484 holes, each hole having clean edge and a smooth, round wall. Perforations will withstand repeated painting without clogging or filling or impairing the acoustical value.

2. **Bevels painted.** The entire exposed surface of the tile . . . including bevelled edges . . . is finished in attractive oyster-white.

3. **Greater sound-absorbing coefficient.** Tests prove a remarkably high degree of acoustical efficiency and high thermal insulating qualities.

*Made from the long, strong fibers of Douglas Fir*

**DISCUSS THIS NEW ACOUSTICAL TILE WITH YOUR NEAREST SIMPSON DISTRIBUTOR-APPLICATOR**

**ANGELES INDUSTRIES**

984 McGarry Street, Los Angeles, Calif., Phone Vondike 1783

**CONSOLIDATED ROOFING & SUPPLY CO.**

520 South 7th Avenue, Phoenix, Ariz., Phone 47888

**CONTINENTAL LUMBER CO.**

P.O. Box 2042, Boise Idaho Phone 450

**ELLIOTT BAY LUMBER CO.**

600 W. Spokane St., Seattle, Wash., Phone Elliott 8080

**EXCHANGE LUMBER & MANUFACTURING CO.**

P.O. Box 1514, Spokane 7, Wash. Phone Glenwood 1621

**FROST HARDWOOD LUMBER CO.**

Market of State, San Diego, Calif., Phone F-7224

**LUMBER DEALERS, INC.**

1301 Wazee St., Denver 17, Colo. Phone Tabor 6141

**LUMBER DEALERS, INC.**

423 No. 33rd., Billings, Montana. Phone 3911

**UTAH LUMBER COMPANY**

333 W. 1st So., Salt Lake City 9 Utah, Phone 4-4318

**VAN ARSDALE-HARRIS CO.**

595 Fifth St., San Francisco 7, Calif., Phone Exbrook 4404

**ROSE CITY FLOOR**

**& INSULATING CO.**

Railway Exchange Building, Portland, Ore., Phone Atwater 6444

**WOOD FIBER DIVISION • SIMPSON LOGGING COMPANY**  
 Plant at Shelton, Washington • Sales Division 1010 White Building, Seattle 1, Washington

# Simpson

QUALITY SINCE 1895

*—an old established name in western logging and lumbering announces the completion of a new, modern plant at Shelton, Washington, for the manufacture of a better line of INSULATING BOARD PRODUCTS*

- **INSULATING BUILDING BOARD**
- **INSULATING TILEBOARD**
- **INSULATING PLANK**
- **INSULATING SHEATHING**
- **INSULATING LATH**



*Made from the  
long, strong fibers  
of Douglas Fir*

**I**n the rain belt of the Olympic Mountains, nature produces the incomparable Douglas fir whose wood fibers are long, strong and tough. Extensive experiments and tests by the Simpson Research Laboratory have proven these long, tough fibers will produce a stronger, stouter insulating board. As a result of these tests, skilled Simpson technicians have created a complete line of insulating board products of superior strength and thermal values . . . for home, office and industry.

A new modern plant at Shelton, Washington, home of many other Simpson industries since 1895, now produces these newly-developed Simpson insulating products.

**ENTIRE PRODUCTION ALLOCATED TO WESTERN DEALERS FOR WESTERN BUILDING**

*Discuss Your Needs with the Simpson Distributors Listed Here, or Write Direct.*

**ARIZONA SASH, DOOR & GLASS CO.**

521 S. 9th Ave., Phoenix, Ariz.  
Phone 3-3151

**CALIFORNIA BUILDERS' SUPPLY CO.**

700 Sixth Ave., Oakland 4, Calif.  
Phone Highgate 6015

**CALIFORNIA BUILDERS' SUPPLY CO.**

19th & S Sts., Sacramento 14, Calif.  
Phone 2-0788

**CALIFORNIA PANEL & VENEER CO.**

955-967 So. Alameda St., Los Angeles, Calif., Phone Trinity 0057

**CONTINENTAL LUMBER CO.**

P. O. Box 2042, Boise, Idaho  
Phone 450

**ELLIOTT BAY LUMBER CO.**

600 W. Spokane St., Seattle, Wash., Phone Elliott 8080

**EXCHANGE LUMBER & MANUFACTURING CO.**

P. O. Box 1514, Spokane 7, Wash.  
Phone Glenwood 1621

**FROST HARDWOOD LUMBER CO.**

327-29 W. Market St., San Diego, Calif., Phone F-7224

**LUMBER DEALERS, INC.**

1301 Wazee St., Denver 17, Colo.  
Phone Tabar 6141

**LUMBER DEALERS, INC.**

423 No. 33rd, Billings, Montana  
Phone 3911

**CHAS. E. SAND PLYWOOD CO.**

1106 N.W. 16th Ave., Portland, Ore., Phone Atwater 6421

**SIMPSON INDUSTRIES, INC.**

1610 E. Washington Blvd., Los Angeles, Calif., Phone Prospect 6183

**SIMPSON INDUSTRIES, INC.**

Shelton, Wash., Phone Shelton 611

**UTAH LUMBER CO.**

333 W. 1st So., Salt Lake City 9, Utah, Phone 4-4318

**VAN ARSDALE-HARRIS CO.**

595 Fifth St., San Francisco 7, Calif., Phone Exbrook 4404

**WESTERN DOOR & SASH CO.**

5th & Cypress St., Oakland 7, Calif.  
Phone Templebar 8400

**WOOD FIBER DIVISION • SIMPSON LOGGING COMPANY**

*Plant at Shelton, Washington • Sales Division 1010 White Building, Seattle 1, Washington*



**Handweavers  
At Work**

## CONTEMPORARY HANDWEAVERS ASSOCIATION OF CALIFORNIA

Beauty is the keynote and the theme is modern at the Contemporary Handweavers' Association of California.

Holding their first showing at the de Young Museum, the association plans through organization to maintain a high standard in their field. Stressing the combination of good taste and wearability, their aim is to educate the public to good handweaving and to have the label on their work denote quality. Only top craftsmen of California are admitted to membership in their organization. Dorothy Wright Liebes of San Francisco, Tilly Lorsch of Los Angeles, and Mrs. Lea Van Puymbroeck Miller, asst. professor of Decorative Art and Design at the University of California in Berkeley are among the guest exhibitors.

Composed of both professional and commercial

handweavers, the Contemporary Handweavers use original design based on color and texture with no use of traditional patterns. Using new and different yarns, tufts of wool, metal threads in sparkling opalescent vivid tones, and a great amount of things coated with plastics, including synthetics, they blend both colors into interesting geometric and striking designs.

This type of weaving is becoming known as "California Weaving," and California textiles are already beginning to be admired throughout the nation.

Featuring weaving for curtains, upholstery, screens, wall hangings, lamp shades, table mats and linens, the artists have a tie-up with practically everything in color for the modern home. Enthusiasm and co-operation exists between the



**Exhibition—  
M. H. de Young  
Memorial Museum**

weavers, architects, decorators, potters, and florists.

In the world of fashion manufacturing, the Association has created new interest with their fabrics for suit material, coats, handbags, linen dress material, play clothes, and beach wear, including sports jackets, and neckties.

Working directly with decorators and architects, the commercial weavers create rooms of harmony. The use of textiles is of great importance since the trend in modern architecture is turning toward space and texture for effect. By working together, the weaver, decorator, and architect can produce a correlated unit of textiles for the home of today.

The Board Members of "The Contemporary Handweavers Association of California" include Frances Cohn, who does hand dyed yarns (especially linens) which are distributed under the name of "Siminoff," Ilse Schultz, Professor at Mills College in Oakland, Ellen Bangley and Barbara Carling, Textile Designers.

The exhibition also features several Bay Area potters, who have made special dinner ware, and harmonizing table mats and napkins. Several arrangements have been done on unusual shaped tables showing how textiles can effectively be used in the home.

Furniture and dishes from Baldorf, Gumps, and Cargoes are on display. Forming an interesting part of the showing are the "Blown-up" architectural plans, and a screen covered with a hand-woven textile, designed and made by R. Benson Alexander.

**DISPLAY OF CRAFTSMANSHIP**

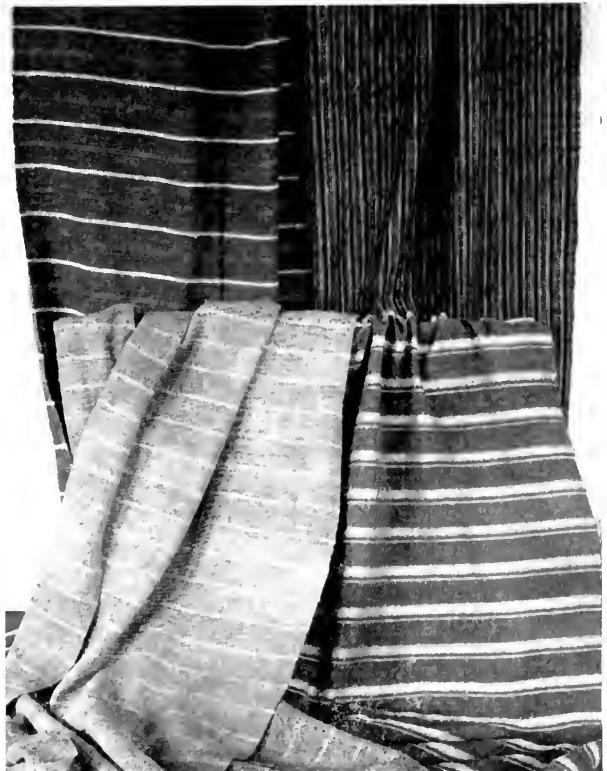

## CALIFORNIA PALACE OF THE LEGION OF HONOR

Thomas Carr Howe, Jr., Director of the California Palace of the Legion of Honor, has announced the following schedule of exhibitions and special events for May:

**EXHIBITIONS: WAR'S TOLL OF ITALIAN ART**, exhibition arranged by the American Committee for the Restoration of Italian Monuments. Opening May 8.

**PAINTINGS** by Hassel Smith. Opening May 2.

The Alma de Bretteville Spreckels Collection of Sculpture by Auguste Rodin.

The Mildred Anna Williams Collection of Paintings, Sculpture, Tapestries and Furniture.

The Collis Potter Huntington Memorial Collection of 18th Century French Paintings, Sculpture, Tapestries, Furniture and Porcelain.

**CHILDREN'S ART CLASSES:** Regular classes for children, ages four through twelve, will continue each Saturday morning at 10:30. Instruction in the use of a variety of media will be given by Katharine Parker, Lilly Weil Jaffe, and Rex Mason. Admission free. There will be no classes in June.

**ADULT PAINTING CLASS:** The Painting Class for adults, under the direction of Rex Mason, will continue through May, each Saturday afternoon at 2:30. Admission free. There will be no classes in June.

### SPECIAL PROGRAMS:

Organ Recital by Uda Waldrop, every Saturday and Sunday, 3:00 P.M.

Organ Concert Broadcast at 3:30 P.M., Saturday, Station KSFO.

**FREE MOTION PICTURES:** Each Saturday afternoon at 2:30 P.M., admission free.

## CALIFORNIA SCHOOL OF FINE ARTS

The Summer Photography Session will emphasize the expressive aspect of the art with the camera as a creative medium. Three field trips of several days duration are planned: A four-day trip to Point Lobos at Carmel; A large industry in the Bay Area; Various parts of San Francisco to record the city, its streets and people.

The class will be limited to thirty students and will be held from June 23 to August 1.

**SUMMER SESSION** beginning June 23rd: Thirty-three day and evening courses will be offered during the six-week summer session, with students urged to register early. MARK ROTHKO and JEAN VARDA will appear as guest instructors in painting and design.

Other instructors will include Elmer Bischoff, William Gaw, David Park and Hassel Smith, painting, Ernest Mundt, design Walter Landor, color; Clayfford Still, pictorial form; Antonio Sotomayor and Edward Corbett, figure drawing.

Squire Knowles, perspective drawing; Ray Bertrand, etching in lithography; Zygmund Sazevich, sculpture; Whitney Atchley, ceramics; Minor White, photography, and Franz Bergmann's jewelry design.

Mary Hiatt will conduct classes for a limited group of children of pre-school age, and Jean Kewell, will instruct students of school age.

## M. H. DE YOUNG MEMORIAL MUSEUM

To honor the most important acquisition made by the Museum in recent years, El Greco's "St. John the Baptist," an El Greco exhibition will be held in May. It will be a small and select showing of paintings by El Greco borrowed from museums and private collections. Among the museums represented will be the Metropolitan, New York, Philadelphia, Minneapolis and Kansas City. Several private collectors will also contribute to the exhibition, including Mr. F. H. Hirschland of New York, Mr. and Mrs. Ralph Coe of Cleveland and Mr. Oscar Cintas of Cuba.

**EXHIBITIONS** for May will include: **STUDENT'S ART**—Selected works assembled by Northern California Junior College Association; **WATER-COLORS OF FLOWERS**, by Panrace Bessa, 1772-1835; **THE MEDIEVAL SPIRIT** (loaned by Life Magazine), opening May 23; **TEXTILES FOR YOU AND YOUR HOME**, Contemporary Handweaver's Association of California; and **CHINESE LOWESTOFT PORCELAIN**.

**SPECIAL LECTURE:** Gallery talk on the Exhibition—Textiles for You and Your Home, Renaissance of a Traditional Craft.

**ART CLASSES FOR ADULTS:** Conducted by Charles Lindstrom.

**PAINTING FOR PLEASURE:** A course designed especially for those who, though interested in art, think they "can't draw a straight line". The series is of ten weekly classes in lecture, demonstration and experiment by class members in basic devices of seeing and drawing. It is given on Saturday mornings from 10:15 to noon and on Wednesday afternoons from 2:00 to 4:00. Classes are free of charge, and materials are provided.

A **CONTINUATION CORSE** for those who have already completed the beginning course in **PAINTING FOR PLEASURE** is also given on Saturday and on Tuesday afternoons from 2:00 to 4:00.



**ART CLASSES FOR CHILDREN:** Conducted by Miriam Lindstrom.

**INTERMEDIATE Class in Drawing:** Saturday afternoons, 2:00 to 4:00: This is a class for young people from 10 to 15 years old who are seriously interested in art. The course is free, materials provided.

**CHILDREN'S Class:** Saturday mornings, 10:30 to 11:30: This is a class in drawing, painting and clay modeling for children from 5 to 10 years old, free.

---

### **CITY OF PARIS ART IN ACTION**

Beatrice Judd Ryan, director, announces an unusual showing and keen competition in the annual Pacific Coast Ceramic Exhibition and Sale by sculptors and potters of the Pacific Coast which will continue in the Rotunda Gallery (4th Floor) until June 7th.

Laura Anderson, Whitney Atchley, Vivika Timiriassieff and Ruth Cravath Wakefield, assisted by Beatrice Judd Ryan, director, have been chosen the Jury of selection and awards. Edith Heath will serve as an alternate.

An Exhibition of Guatemalan Hand Woven Textiles, featuring yardage, Jacquets, belts, and dolls, and a group of watercolors "Fisherman's Wharf In All Its Moods" by Harry Reeks will also be shown.

---

### **MILLS COLLEGE ART GALLERY**

The following exhibition will be held in the Gallery from April 13 to May 16.

Paintings and Watercolors by Theodore Polos; "The Face of the Orient" photographs by John Guthmann; and U.S.A. Houses, 1607-1946. The showing of U.S. Houses will close on May 6.

---

### **AMERICAN STANDARDS IN CHINA**

China will adopt the standards of processing and production that are in general application in the United States, Dr. Wellington Koo, Chinese ambassador to the U. S., stated in a recent article in "Industrial Standardization," published by the American Standards Association.

Dr. Koo emphasized the importance of an extensive program of industrialization in China as a means of ameliorating the desperate poverty of the Chinese masses. "I firmly believe that its importance cannot be overestimated," he said.

A three-point program has been decided upon, having as its objective the development of the country's vast natural resources: (1) simultaneous development of both heavy and light industries; (2) regional development, dividing the country into seven principal regions; and (3) an industrial

system based on free enterprise, but blended with government ownership in some industries, such as enterprises relating to national defense and enterprises requiring large-scale equipment which private interests are not in a position to undertake.

Pointing out that China produces large quantities of such products as bristles, tungsten, anti-mony, tea, and wood oil, Dr. Koo underlined the importance of better processing of these items so they will find a larger market in the United States. This, in turn, will increase the purchasing power of the Chinese people and enable them to buy more from the United States, he explained.

---

### **NEW YWCA LOUNGE FOR SO. CAL.**

The architectural firm of Orr, Palmer, Inslee & Huber of Los Angeles are drawing plans for a meeting and lounge building to be constructed for the Young Women's Christian Association, campus of the University of Southern California.

The building, 90 x 135 feet, will contain the Elizabeth von KleinSmid memorial lounge; Walter Butler clubroom; banquet hall, kitchen, offices, meeting rooms, sanctuary, patio, and multiple sanitary and service facilities.

Construction will be of reinforced concrete and brick, Type 1.

---

### **LESS "FANTASTIC" TUNNEL FOR CASCADES**

A two-mile bore under the summit in Snoqualmie Pass in the Cascade mountains of Washington State has been recommended for possible action by the state legislature.

Although it comes as an anti-climax to the proposed "fantastic" 29-mile tunnel through Stevens Pass, which was previously considered and declared prohibitive, the project on the current agenda is felt to be much more practical from every point of view.

It would take advantage of the best terrain, avoiding the steepest grades and the areas most difficult to keep clear of snow. Its estimated cost of \$22 million would be recovered by making it a toll tunnel, which would retire the revenue bonds issued.

When completed it would give the State of Washington and east-west all-weather highway with only a 3 per cent grade between Seattle and Spokane.

---

### **NEW BUSINESS**

John J. Donovan and Ralph N. Kerr, announce the formation of a partnership for the practice of Architecture at 950 Parker Street, Berkeley, California.



VIEW OF INTERIOR FROM MARKET STREET ENTRANCE

C. BOLTON WHITE, A.I.A. Architect

# DESIGN FOR SELLING

## Rucker-Fuller Co., San Francisco

By EUGENE BURNS

When the owners of 70-year old Rucker-Fuller Co., of San Francisco, one of the largest sellers of office furniture in the United States, decided to renovate their main store at 559 Market Street, they gave their architect, Bolton White, these instructions:

"Break away from the dreary common-place atmosphere of the usual office furniture display room. Our building must be so attractive in design, so vital in color, and so beautiful in materials that passersby will have to succumb to their natural impulses, walk in, try out our office chairs, and imagine themselves executives in an office of their own.

"Above all, Rucker-Fuller wants every piece of office furniture—whether it is in display rooms, accounting office, conference room, executive offices, or the rooms devoted to interior decoration, layout and artistic work—to be a living exhibit."

In short, Rucker-Fuller's wanted a building which was not a store at all but an establishment to show office furniture in use.

Architect Bolton White of San Francisco whose background is studying at Stanford University, Columbia University, and Fontainebleau, France, and teaching at Stanford, had these things given him to effectuate the requirements:

"First," he said, "I was fortunate in having

clients who were imaginative enough to want something new and daring enough to see it through.

"Next, I was handed a building—sixty feet by one hundred and fifty-five—which gave me adequate space to implement sweeping design.

"And finally, the opportunity was mine to do something new—design an entire office furniture building devoted to display."

White did just that: he gave Rucker-Fuller's an interesting background to compliment rather than to compete with their product.

In renovating a building an architect is usually confronted with fixed elements which must be incorporated into the design. At 559 Market Street, Architect White found floor space bisected with a line of unsightly columns with large caps, and elaborately furred. A large girder ran the full length of the building. A hung mezzanine encircled the perimeter. An ugly box-like structure, located within ten feet of the window, housed an elevator and blocked off width. Two narrow sets of stairs—one leading to the mezzanine, the other to the second floor—flanked the open area, further cutting down the width. As though by wilful intent, these impedimenta were badly spaced.

#### Exterior Suggests Interior

Upon approaching the entrance today, the visitor is impressed immediately by the street-level, glassed-in front. The glass is recessed, which reduces glare, and gives passers-by a quiet, com-

fortable pool to step into, out of the eddying crowds. The glass doors, double-acting, elegant but purposely unpretentious, are a part of the glass plane. They are recessed still further to encourage a flow into the building. The caller has but to "push" the door to be in the furniture displays shown as they would be in an office.

The exterior, whose simplicity borders on austerity, throws the emphasis on the interior where

### DESIGN FOR SELLING Rucker-Fuller Co.

Architect: **C. Bolton White, A.I.A.**

Consulting Engineer: **Hyman Rosenthal**

Electrical Engineer: **Taylor & Williamson**

General Contractor: **Stolte Inc.**

Air Conditioning & Plumbing: **Scott Co.**

Stair Builders & Wood Products: **J. di Cristina & Son**

Wiring & Fixtures: **Manning & Whitaker**

Acoustical Tile: **L. D. Reeder Co.**

Cathon Electric: **Spott Electric Co.**

Mill Work: **Hollenbeck-Bush Planing Mill Co.**

Elevator: **Pacific Elevator & Equipment Co.**

Roofing: **B. B. Perkins Co.**

Wood Carving: **California Wood Carving Co.**

Sign: **Swan Sign Co.**

Rugs & Carpets: **W. & J. Sloane Co.**

*Photos: Richard H. Mercer  
Haas & Associates*

RUCKER-FULLER COMPANY—WORKING AND BUSINESS STAFF HEADQUARTERS



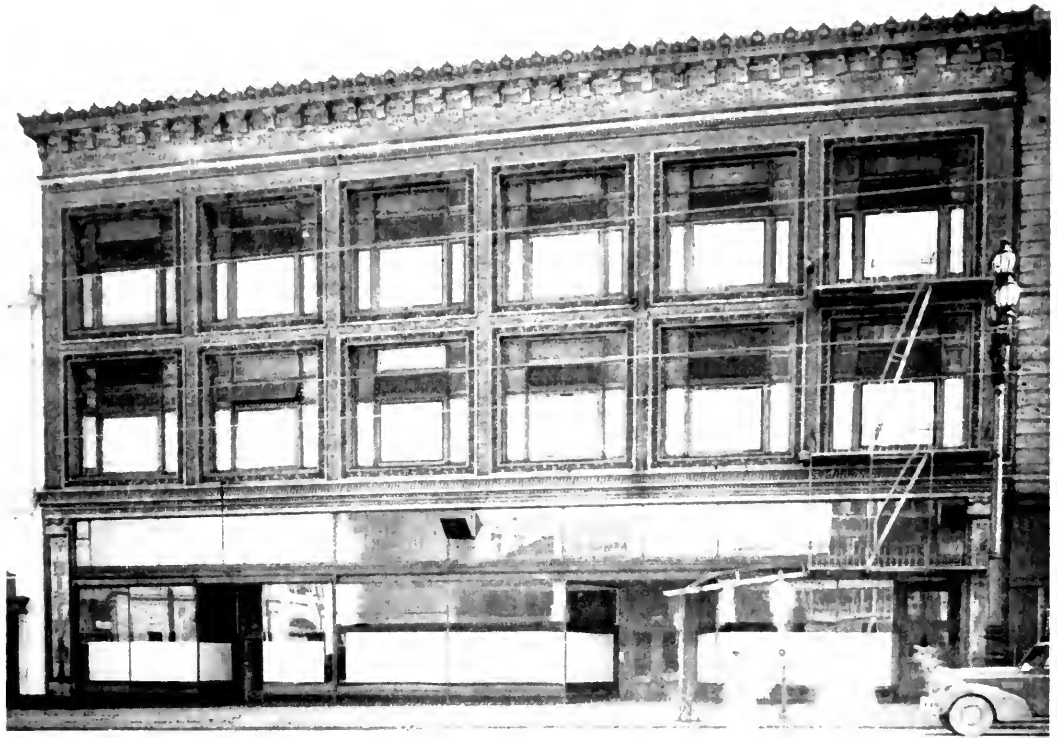

**ABOVE:** View of the Market Street building before work of remodeling was started—the entire portion comprising the street store front and mezzanine level was redesigned.

**BELOW:** Interior of the ground floor prior to remodeling. The problem of large center pillars and mezzanine space with unsightly stairway is clearly shown.



it should be. However, the use of golden marble enriches the front. To reduce cost, White did not carry the marble above the interest line.

But yet, the exterior, however plain, prepares the visitor for what is to come within. An architectural honesty exists between exterior and interior. The window panes, for example, are divided by piers which prepare the eye for the columns within. The color of the piers, too, is repeated on the columns within and it gives a preview of the forty-some shades used on the first floor. Even the wooden push bars on the doors are in the form of the outside piers and made of richly grained wood which also suggests the natural wood the visitor is about to see in the furniture within. The maximum use of glass, one feels almost instinctively, will be repeated inside. And it is!

**Dramatic Colors**

When the visitor enters the building, he is at once struck by the bold use of colors—reds, yellows, dark greens—colors once held taboo in offices. And yet, the color is used functionally to accent or subordinate, as needed, thereby giving a subdued and rich effect. For this dramatic use of color, which must be seen to be appreciated, Architect White credits Rucker-Fuller's own Interior Decorator, John Rex, who has done many of San Francisco's smartest offices. Rex selected and blended the colors and their placement during the

six months-long operation.

Briefly, in choosing the colors, Rex employed three basic tenets: What is the purpose of the room? What atmosphere is sought? What personalities are involved? In the large display room, for example, he used colors that would be pleasing to the majority. For the executive offices, he formed backgrounds to accentuate the personality of the person using the room. Then, before actually starting the painting, Decorator Rex made an intensive study of the lights and shadows and the relation of one area to another.

To better proportion the space on the main floor, Architect White gave a new curved valance wall to the mezzanine which encircled the perimeter. The existing curve along the east side was extended toward the center of the west side, thus taking the line of columns off dead center. At the same time, White stripped the twelve-inch cast iron columns of their elaborate columnar furring and allowed the columns to exist for what they are. A furred ceiling, further gave better proportions, simplified the lines and covered the unsightly girder line above the columns. Because the cast iron column caps came down too low to be covered by the twenty-foot high furred ceiling, White neutralized them by the simple expedient of holding the ceiling away from the columns, and by paint-

(See Page 27)



**Modern Design of Interior—Indirect Lighting and Glass Partitions**

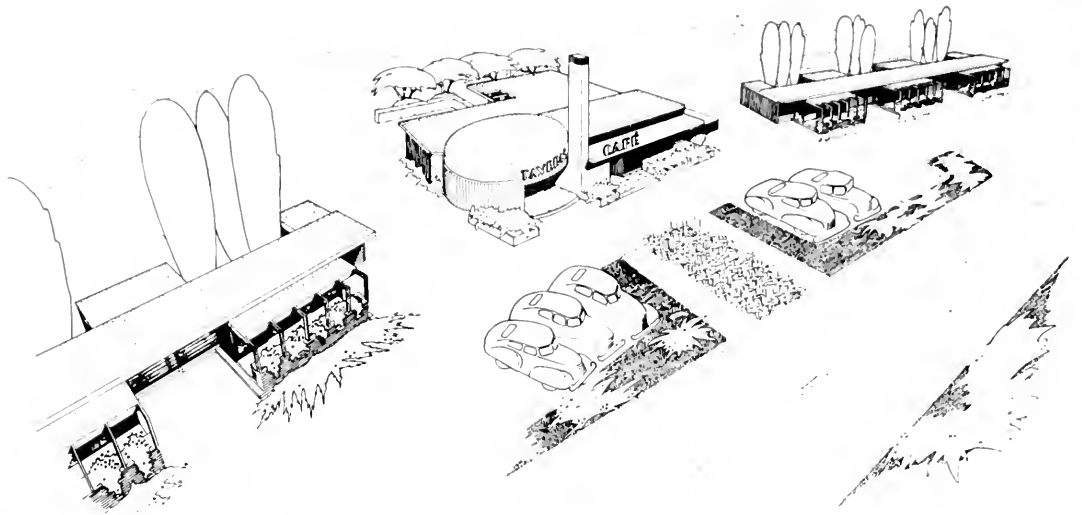

FIRST UNITS OF OVERALL PLAN

# CALISTOGA MOTEL

## CALISTOGA, CALIFORNIA

By **JAMES H. GARROTT, Architect**

The bleak little white auto court or motel unit, with holes punched in on each side for air and light and a slot cut in the middle of the front wall for an entrance, is becoming as much of a thing in the past as is the horse and buggy. The automobile tourist of today will be satisfied no longer to swing off the highway up a dusty, weed bordered path to a musty little room for an uncomfortable night's sleep. Until recently, most builders of motels seemed to be of the opinion that the unit

was just a spot for the tourist that cared merely for shelter over his head, in preference to sleeping in an upright position, to close a hard day's grind at the steering wheel. He was sure that the motorist was to suffer enroute on his vacation trip, going or coming, but felt that he would be rewarded at either terminus. At one goal was his vacation spot of paradise that he had talked about and waited for all year, but suffered getting there, and at the other end was home where he had to take a few more days rest to recuperate from a long and tiresome trip.

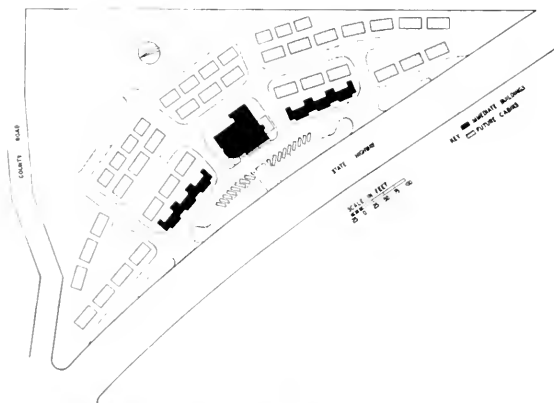

Complete Project—Units under Construction

Adolph Devencenzi and John Cavaglieri were aware of these facts and believed that the motorist was due a better deal when they selected a site on State Highway No. 29 in the upper end of the beautiful Napa Valley, not for motel units or auto courts but, for tourist cabins of distinction, cabins that no motorist could afford to pass "looking for the better" down the road. The owners were clever and far-sighted in selecting a site for the first fifty cabins amid a colorful vineyard on one of the most scenic highways in Northern California. When completed the total project will cost \$250,000. The plot is located just out of the town of Calistoga that was founded by Samuel Brannan

in 1850 with the intention that it become the Saratoga of the west. It was also the home of Robert Louis Stevenson who roamed the valley and the surrounding hills while writing his famous novel "The Silverado Squatters", and other stories of early day quicksilver mining in California.

Any motorist, stopping for an overnight rest, would be tempted to prolong his stay when he gets his first early morning view of a natural hot water geyser within walking distance of the cabin. The whole area abounds in natural beauty. The architect has taken advantage of this by giving every cabin a portion of the scenery for a view. Cabins that do not have the geyser view, have either the view of the green hills of the Coast Range and Mount St. Helena in one direction or the darkened woods of the petrified forest in the other. One side of the property borders the old Silverado Trail that leads to the nearby quicksilver mines. This project should be regarded as a resort more than just a stop over spot for a good night's rest.

Because of material shortages and other hindrances beyond the control of the building program, the project is progressing rather slowly. The administration building is nearing the completion stage and a few cabins will be ready for occupancy very soon. The entire project should be ready by the first of June. There will be a variety of cabins. Next to the highway will be de luxe cabins with bath between two sleeping rooms for two couples traveling together. For the single couple there will be cabins with one sleeping room and bath. For tourists with families that care to prepare their own meals, there will be cabins with kitchens and eating space. All cabins have private baths and dressing alcoves.

Since the winter is quite variable from the summer (See Page 25)

(See Page 25)

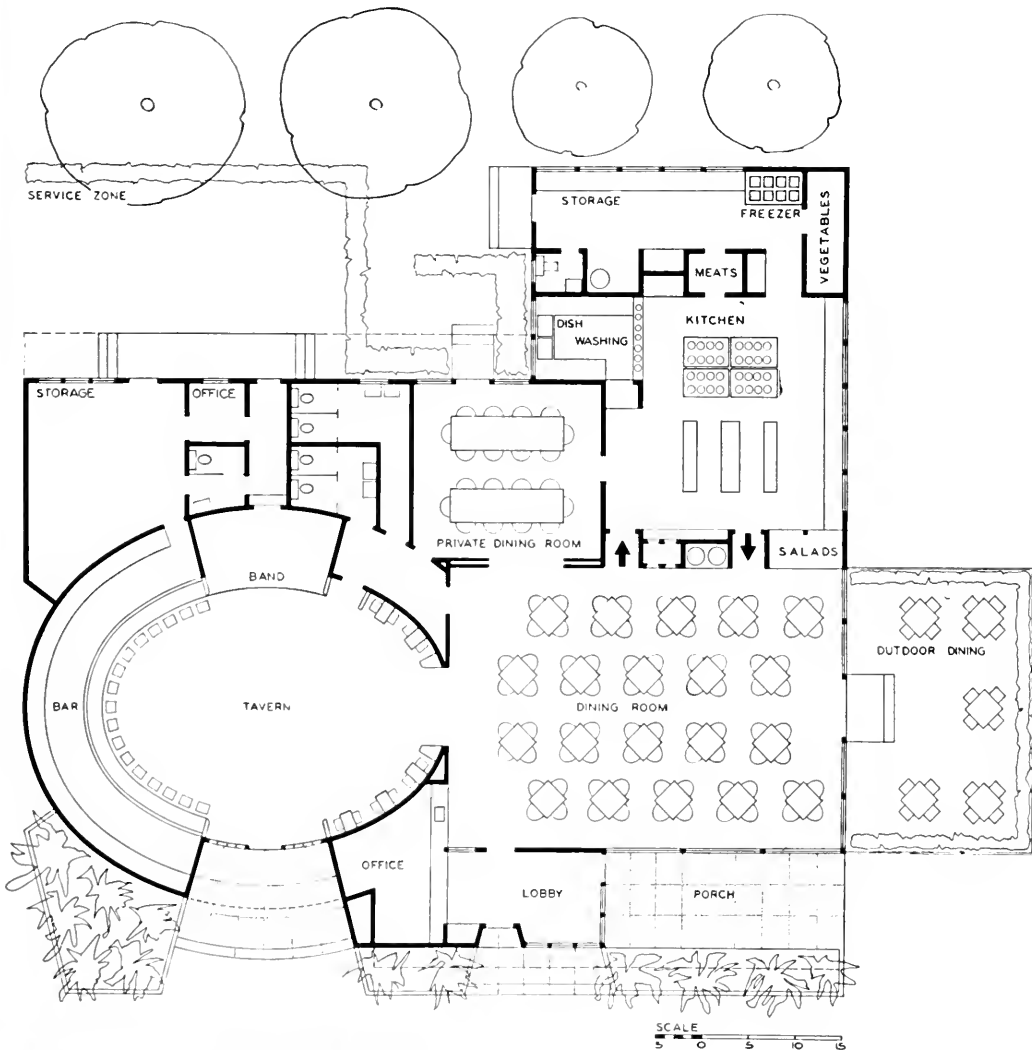

PLAN OF MAIN ADMINISTRATION BUILDING



NEW STORE ENTRANCE—Recessed Display Windows

# *The* ROBERT S. ATKINS

## STORE MODERNIZATION

By DONALD BEACH KIRBY, A.I.A.

Forty years ago San Francisco and the Robert S. Atkins store arose from the ashes like a Phoenix. For the store, established in 1860 when Clipper Ships were the latest style in ocean travel, had served the city well in the same location and with quality goods for all those years.

Today, the name "Atkins" is again on everyone's lips, for the traditions of quality and service are now being carried on in the completely modernized store.

From the name "Atkins" in the terrazzo a modern tempo has been established throughout and

ARCHITECT AND ENGINEER



## . . . ROBERT S. ATKINS

the design, color, lighting and arrangement of space have been synchronized to this tempo. A few old-timers may miss the dangling lighting fixtures and the "mahogany" columns but they soon feel at home in the atmosphere of this friendly and convenient store.

The decision to recess the main show windows created a sheltered and distinctive approach. The hustle of the financial district continues, but men and women may examine the window displays in leisurely fashion.

When colors and materials were chosen the masculine tastes were recognized. The ceramic veneer in reddish-brown and its color complement gray-green, is permanent, clean and strong. The large bordered windows with heavy wood frames; the stainless steel trim; the terrazzo pavement, all represent solidity and are styled to harmonize. An upper canopy frames the front as a feature and the lower marquee offers protection from the weather.

The show windows are large enough to accommodate manequins or a variety of other displays. All window lighting is concealed and ranges from adjustable spotlights in the "egg-crate" baffle overhead to footlights such as are used on a stage. This permits the use of combinations of colored lighting and spots. Boxed ruscus on the upper-canopy lends a note of green foilage as a foil to

### ROBERT S. ATKINS MODERNIZATION

Architect: **Donald B. Kirby, A.I.A.**  
Industrial Designers: **Burke & Kober**  
Structural Engineer: **John A. Blume**  
Paint Contractor: **Charles E. Gordon Co.**  
Electric Contractor: **Beacon Electric Co.**  
Terrazzo Contractor: **American Terrazzo Co.**  
Fixtures & Cabinet Work: **Mullen Manufacturing Co.**  
Linoleum & Rubber Floor: **L. D. Reeder Co.**  
Fluorescent Luminaires: **Leader Electric Co.**

*Photographs: Moulin Studios*

#### DETAILS OF ENTRANCE





**DETAILS OF INTERIOR DESIGN—Emphasize wide aisles for patrons; low displays for better inspection; large open type show cases, and congenial overhead design, which with floor covering and lighting makes for a truly modern store.**



**Design of  
Men's Clothing  
Section—Ample  
Display and Light**

Attractive  
Entrance to  
Women's Suit  
Section. . . .  
Unusual Display  
Area and  
Lighting.



GENERAL INTERIOR VIEW—Spaciousness with ample display





**NO HARSH CORNERS** — Furnishings and display areas harmoniously emphasized with series of indirect lighting fixtures.

the straight, simple lines of the front and the flat panes of glass and masonry.

Passing through the entrance one feels a sense of welcome and openness. The large, tempered glass doors and wide sidelights form a "visual front" and open a vista of the interior and its wares. The aisles are generous in width, displays are kept low to avoid confusion and the eye easily finds the department or particular article desired. Everything possible has been done for the convenience of the customer, and service facilities function efficiently but unobtrusively. A modern pneumatic tube system replaces the old cash baskets which used to fly across the store on a wire (to the alarm of the taller customers).

Growing with "the city", the store has been enlarged by some 7,000 square feet of space. This area houses the new Women's Shop, the Sportswear Department, the offices and the greatly improved tailor shop.

The extensive use of very definite color and the most modern types of lighting are the features which are, perhaps, most striking in this modernization project. In the old store the dark columns showed up "like sore thumbs" against the light walls and ceiling. In the new store brick red is

# **PAINTING AND DECORATING**

COMPLETE PAINTING, DECORATING,  
PAPER HANGING AND HARDWOOD  
FINISHING AND REFINISHING

In the Modern  
ROBERT S. ATKINS STORE



## **CHARLES E. GORDON**

Over Forty Years of Reliable Painting Services.  
Stores, Offices, Industrial, Residence.

3245 - 16th Street San Francisco Underhill 7717



Quilted synthetic leather and sunken displays form entrance to the shoe alcove.

The general effect is of a brightly lighted store but there is no sense of "glare" because of the balance of fluorescent and incandescent illumination. Spot lights are of the "swivel" type and are adjusted to pick any desired feature. Wood finished on walls and fixtures has been kept light in color—"modern" fruit wood tones—fresh and neutral. The brick red is complemented by light gray greens

used on walls, ceiling and columns alike to make them an unobtrusive background. Attention is focused on feature displays, and the merchandise. The lighting has been lowered to a level of fourteen feet and the equipment lighting to seven feet or less. Each case and display is lighted in addition to the general lighting of the store which consists of fluorescent fixtures combined with incandescent spot lights. Natural daylight, long a feature in Atkins, has been retained but is supplemented by the fluorescent lighting. To eliminate the appearance of having a great many light fixtures, a unit was selected which has luminous sides and creates the impression of long lines of light source.

**Store Fixtures and Cabinet Work**

for

**Robert S. Atkins**

Furnished by

**MULLEN MFG. CO.**

UNderhill 5815

60 RAUSCH STREET

SAN FRANCISCO

**L. D. REEDER CO.**

GOODYEAR RUBBER FLOORING

for

**ATKINS**

LINOLEUM AND ASPHALT TILE

DOuglas 5050

100 SACRAMENTO STREET

SAN FRANCISCO

**TERRAZZO FLOORS and  
MODERNISTIC DESIGN**

for

**ROBERT S. ATKINS**

**STORE**

by

**American Terrazzo Co.**

36 WOOD ST., SAN FRANCISCO

WALNUT 1-1862

Electric Wiring and Fixtures

in

**ROBERT S. ATKINS STORE**

by

**Beacon Electric Co.**

ELECTRICAL CONTRACTORS

Phone YUkon 6-2782

155 CLARA STREET

SAN FRANCISCO

## ROBERT S. ATKINS . . .

and this harmony is brought out by the lighting.

In the Fitting Rooms, Tweed Shop and Sportswear sections a gay wall papered cornice has been used—the pattern is unique—a conventional treatment of a buffalo motif. Sheet rubber floors, in tones of buff and terra cotta, are clean, quiet and resilient.

The Tweed Shop provides a new feature. Shelving chairs and mirrors were arranged particularly for these activities. Walls and cases are of beautifully grained ash, light and natural in color. Fixtures in the Sportswear Department feature special facilities. Some cases provide for "ledge selling" where the showcase is eliminated and the customer examines the article right out of the stock.

The Shoe Department has a special alcove arranged so that a large stock of shoes is conveniently at hand and a customer does not feel that he is out in the middle of a selling floor. The walls of the Shoe Department carry out the sense of fine quality leather by the use of quilted synthetic leather secured with brass nails forming a distinctive pattern.

Many difficulties arose as this job progressed and was constructed—some materials were not obtainable—some were delayed—rebuilding some of the old work was very complicated. However, throughout the building program, the partners, the



Unusual display features entrance to the sportswear section.

staff, and particularly, the clientele of "Atkins" have been very patient and cooperative. When the front was barricaded to permit the new windows to be recessed the window trimmer had to get along with two or three small temporary shadow box windows—when dust from the removal of old plaster fell on the neckties, the staff brushed it off—and still smiled! .

LIGHTING BY

*Leader*

in the magnificent new

ROBERT S. ATKINS STORE

San Francisco

Look to Leader for America's  
Finest Line of Fluorescent Luminaires

**LEADER ELECTRIC COMPANY**

2040 LIVINGSTON STREET

OAKLAND 6, CALIF.

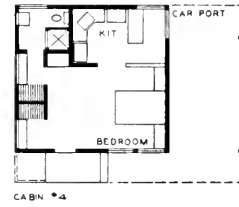
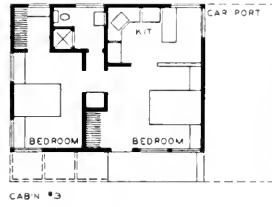
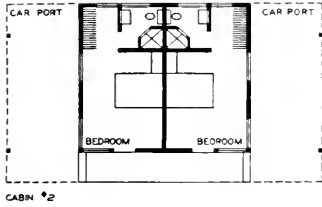

mer and the nights cool compared to the days, the walls and ceilings had to be well insulated. All cabins are electrically heated and air cooled. No hot water tanks are necessary. The architect, knowing that the Napa Valley is noted for its mineral springs, had two wells bored on the property. One well brought forth cool refreshing mineral spring water that is being piped to each cabin for drinking purposes. The other well was bored a few hundred yards from the first and it furnished a terrifying stream of hot mineral water that is being piped to each shower and bath tub. No storage tanks are necessary as each well has about 60 pounds natural pressure from the earth. For sanitary reasons all furniture will be of steel. Chairs to be leather covered. Each cabin will have its private garage or car port. All driveways and walks will be paved with black asphalt. The grounds around the administration building and cabins are being profusely planted with mostly natural flora.

The administration building, located directly on the highway, is equipped with a dining room for transit patrons, and also for cabin patrons that do not care to prepare meals. Large plate glass windows in the dining room frame the west view of the vineyard and distant mountains. On warm days out-of-doors dining may be enjoyed. The kitchen equipment will be of the very best. A large stainless steel lined refrigerator will be big enough for storage of more than a month's supply of meat. All stoves, steam tables, dishwashing machines,

refrigeration and all other equipment in the kitchen, tavern and other parts of the building will be electrically operated. The entire building is to be air conditioned and heated electrically. There will be no old fashioned chandeliers, or miner's oil lamps hanging around, all lighting will be indirect with florescent tubing. Next to the dining room is the tavern with a small dance floor. The inverted bar in the tavern is one of the few in the United States. The advantage of the inverted bar is that from no vantage point will the customer be able to see behind the bar counter. The bar's speciality in drinks will be an assortment of fine wines made from grapes grown in the community, for Napa County is one of the greatest grape producing counties in the United States.

A fresh approach must be made to the auto court even though it may soon become the gyro-court. The motel and tourist cabins are here to stay or let's say for a long time anyhow. The demand for modern dwellings, motels and restaurants is a demand for modern cabins and the like. Modern exterior lines, well selected colors for walls, good interesting materials are as important to the cabin in the mountains as the dwelling in the city. Interesting views, a good location, as well as air and sunshine must be considered. The architect and owner was aware as to location and design for the cabins at Calistoga. The bleak little white boxey auto court with holes punched in on each side for air and light and a slot cut in the middle of the front wall for an entrance is gone forever.

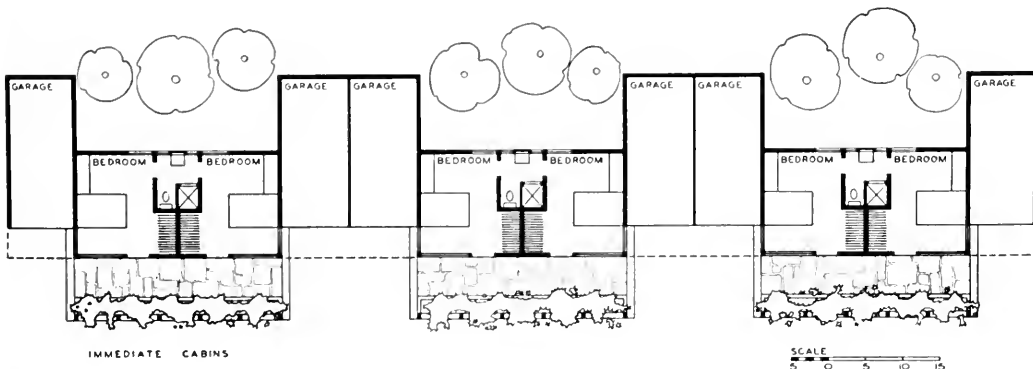

# IN THE NEWS

## GYPSUM ASSOCIATION

The Pacific Coast Division of the Gypsum Association recently announced the opening of offices in the Architects Building, Los Angeles, under direction of Henry J. Schweim, secretary-manager.

## WEST GETS LARGE SHARE OF INDUSTRIAL CONSTRUCTION

The San Francisco and Los Angeles regional offices of the Office of Temporary Controls, which succeeded the Civilian Production Administration, have handled 19% of all industrial construction applications granted in the country, recently released data indicates.

Out of a national construction total of approximately \$2 billion since March, 1946, when non-housing construction went under Federal controls, \$178 million was covered by applications granted through the Los Angeles office, and \$207 million through San Francisco.

## PRIVATE HOUSING PROJECT

A private housing project consisting of 75 five-room and 39 six-room dwellings will soon get under way at Baldwin Park, Los Angeles county; total estimated cost to be \$1,200,000. Contractor is Thomas Western Co. of San Marino.

## BOILER AND TANK REVISION PROPOSED

A revision of the Simplified Practice Recommendation R8-42, Range Boilers and Expansion Tanks, that would add a double extra heavy grade for each size range boiler, has been proposed, according to the National Bureau of Standards.

It is proposed to expand the scope of the recommendation to include galvanized solar tanks, and add a ten gallon expansion tank. Copies of the proposed revision may be obtained from the Division of Simplified Practice, National Bureau of Standards, Washington 25, D. C.

## MORTGAGE FINANCING AMPLE

Mortgage foreclosures are at the lowest rate in history, lower than the delirious days of the 20's, according to Roy Wenzlick (Real Estate Analyst, Inc., St. Louis). "A common trend toward over-lending is very much in evidence," Wenzlick states, "with some tightening on veterans' loans, but ample financing available for the standard type of project."

## S. F. DEPARTMENT STORE EXPANDS

A \$1,250,000 addition to the O'Connor, Moffatt & Co. department store in San Francisco will get

under way soon. A CPA permit has been granted and the Dinwiddie Construction Company of San Francisco will be the general contractor. Architects are W. P. Day & Associates of San Francisco.

## MOOSE HALL

The Richmond, Calif., chapter of the Moose Hall Association have had plans prepared for the building of a \$250,000 lodge building to be constructed of reinforced concrete and structural steel.

## GYM AND POOL

Preliminary drawings are in progress for a new gymnasium and swimming pool for the Concord, Calif., high school, as well as a 10-room classroom building. Total estimated cost, \$500,000. Reynolds and Chamberlain of Oakland are the architects.

## MODESTO HIGH ADDS

S. C. Giles Company of Stockton, Calif., has been awarded the general contract for the building of additions to the Modesto, Calif., high school, totaling \$390,000. Harry J. Devine of Sacramento is the architect.

## 40 APARTMENTS

An apartment building to contain 40 units of 3, 4, and 5 rooms and expected to cost \$250,000 is to be built soon in San Jose, Calif., by the Richmond Lowell Company, with J. Lloyd Conrich of San Francisco as the architect.

## FOODS

Dennison's Foods of Oakland, Calif., have awarded the general contract for the building of their \$105,000 factory addition to the M & K Corporation of San Francisco. W. B. McMillan of Palo Alto is the architect.

## SAN RAFAEL FACTORY

H. M. O'Neil & Associates are the structural engineers for the \$100,000 factory building to be built in San Rafael, Calif., by the H. C. Little Burner Company of the city. It will be a one story frame construction, Marin Corp., of Sausalito, general contractor.

## BUILDING RESTRICTIONS

It's likely that restrictions on home building will be off by June, the National Association of Home Builders indicates. It is felt that by then the supply of building materials should be sufficient for all construction needs.

The association is also of the opinion that rent control will be gradually abolished by Congress, with the 15% decontrol method apparently chosen as the means of tapering off.





**ILLUMINATION PLAYS IMPORTANT PART** throughout entire store. **Cross partitions, divisional areas and many glass innovations** are designed to localize each portion of the new store.

# STOLTE INC.

## GENERAL CONTRACTORS

Oakland, California

*The New*

### RUCKER-FULLER STORE

*One of Our Contracts*

## RUCKER-FULLER CO. . . .

ing everything black above the ceiling plane. The openings, thus formed between columns and ceiling, not only make the ceiling appear to float free of any support, but also provide return air exhausts for the combined filtered air heating and ventilating system.

Visual continuity of space—giving depth, width and loft—was maintained by dividing the main display room from the adjoining accounting office by a full-height glass screen, the lower part of which is fluted to give the office workers privacy while the upper part is clear to give the building depth. Mirrors to either side of the display room, where doors once were, give the room still more width.

As a relief from the noise of Market Street—San Francisco's busiest thoroughfare—there is a comforting hush of absorbed sound achieved through the use of inch-thick carpeting, acoustic tile and drapes. The carpeting is neutral and has the same rich quality of the Biegenelle marble facing outside.

### Break from the Old

Rucker-Fuller's began their renovation as soon as San Francisco swept up the results of the riotous V-J Day celebration. Confident that the public

would respond to a break from the customary old stodgy office furniture buildings, the 70-year old West Coast Company did not hesitate to give Contractor Stolte, Inc., Oakland, a cost-plus contract despite the risk of rapidly mounting costs in a fluctuating labor and material market.

In those days of "no-have" and "no-can-do", it took improvisation. To install automatic elevators, for example, Sibley Smith persuaded two rival elevator companies to supply each other with needed parts. And they did so willingly. To get glass doors, an exchange was effected by a long-distance call to Detroit! And when the doors arrived, from Los Angeles, they had no fittings so fittings were designed by Rucker-Fuller's and they have proved so effective that other companies are now making requests for similar ones! And to get the Italian marble for the facade, an in-law of the Smiths finally located thirty-five tons of rare, golden Beigenelle in San Francisco sufficient to cover the 1,000 square feet needed.

### Postwar Lighting

For the choice of lighting, Architect White gives Dale Smith the major credit. Dale insisted upon using cold cathode—a wartime development, despite the advice of experts who said: "You'll get color distortion!"; "I've tried it and I'm pulling it out!"; and "It's not been standardized enough to take the gamble!" But yet by persisting, Dale Smith triumphed and as a result San Francisco got an outstanding lighting system, striking in appearance, unexcelled in utility, and extremely low in operating cost.

To avoid over-emphasis, a straight-line, parallel, repetitious layout of tubes near the ceiling was used. The tubes, incidentally, are 20 millimeter

# USE CATHON

**Cold Cathode Lighting for  
All Applications**

Manufactured and Installed by



**OAKLAND, CALIF.  
526 Twenty-second Street  
Phone GL 7277**

Yours for Service

Since 1908

RUCKER - FULLER STORE

**J. di CRISTINA & SON**

**WOOD PRODUCTS  
STAIR BUILDERS**

350 Treat Avenue  
San Francisco

Phone  
HEmlock 8111



**Stairway at Rear  
No Longer Detracts  
From Displays of  
Modern Furnishings.**

3,500° white Cathon on 60 milliamperes. By regulating the parallel spacing of the tubes, intensities of light of 23 to 27 foot-candles were obtained at desk height in the display room and of 45 foot-candles at the same height in the clerical area. For featuring certain display areas, incandescent spots were added. As the lighting was installed while the renovation was in progress, White was able to control the placing of wires, connecting gadgets and electrode bushings within the ceiling, out of sight, thereby giving a simple pleasing effect.

With the flick of a switch, cold cathode gives instant light and frequent switching on and off,

## The ROOF

On the Beautifully Modernized  
New Rucker - Fuller Co. Building

**WATERPROOFED**  
and **PRESERVED** with

### TRIPLE ACTION PRODUCTS

- ASBESTOS ROOF SEAL
- OIL PRIMER
- PLASTIC CEMENT

This is but one of the hundreds of business and industrial properties in the San Francisco and East Bay area that has been waterproofed and preserved with our heavy-bodied industrial roof coating.

Manufactured and Distributed by

**B. B. PERKINS COMPANY**

1478 Havenscourt Blvd.  
OAKLAND, CALIF.  
LOckhaven 8-2531

122 New Montgomery St.  
SAN FRANCISCO, CALIF.  
DOuglas 3007

## PACIFIC ELEVATOR and EQUIPMENT CO.

RUCKER - FULLER

ELEVATOR MODERNIZATION

45 RAUSCH STREET  
SAN FRANCISCO

Phone  
HEmlock 4476



Displays are aided  
by Pleasing Design of  
Walls and Overhead  
Indirect Lighting.

which shortens the life of other lighting systems, neither affects its life expectancy nor its efficiency. Because the tubes never burn out, maintenance costs are much less than for any other type of lighting. However, after 10,000 hours of use—approximately three and a half years—it is recommended that the tubes be reinstalled, at approximately two-fifths of the original cost of installation, because the lumen output of the tubes gradually diminishes about 20 to 25 per cent from the original efficiency.

After six months' use, Rucker-Fuller estimates that the three-thousand dollar installation will pay for itself within two and a half years in reduced electric consumption. The 1,200 foot of tubing consumes only about one-half the electrical wattage of ordinary fluorescent fixtures to achieve the same foot-candles and only one-fifth to one-sixth that of incandescent light.

(See Page 38)

**AIR CONDITIONING & PLUMBING**

for

**RUCKER - FULLER**

furnished by

**SCOTT COMPANY**

San Francisco

Oakland

**Armstrong Cork Co.'s  
CUSHION TONE**

for

**RUCKER - FULLER**

by

**L. D. REEDER  
COMPANY**

100 Sacramento St., San Francisco

**MANNING & WHITAKER**

375 NINTH STREET  
SAN FRANCISCO

1229 - 13TH AVENUE  
OAKLAND

**Electrical  
Contractors**



Wiring and Fixtures  
for the new

**RUCKER-FULLER STORE**

Furnished and Installed



**Arizona Chapter:**

James Macmillan, President; Arthur T. Brown, Secretary, 740 N. Country Club Road, Tucson, Arizona.

**Central Valley of California:**

Herbert E. Goodpastor, President; Frank V. Mayo, Secretary, 307 Exchange Building, Stockton 2, California.

**Colorado Chapter:**

Raymond H. Ervin, President; James M. Hunter, Secretary, 2049 Broadway, Boulder, Colorado.

**Montana Chapter:**

Ralph H. Cushing, President; H. C. Cheever, Secretary, Montana State College, Bozeman, Montana.

**Northern California Chapter:**

Hervy P. Clark, President; Lester Hurd, Vice-President; Ralph Pollack, Secretary; William C. Ambrose, Treasurer; 605 Market Street, San Francisco.

**Oregon Chapter:**

Francis Jacobberger, President; J. D. Annand, Secretary, 401 Central Building, Portland 5, Oregon.

**San Diego Chapter (California):**

H. Louis Bodmer, President; Louis J. Gill, Secretary, 203 Granger Building, San Diego, California.

**Santa Barbara Chapter (California):**

Roy C. Wilson, President; Miss Lutah M. Riggs, Secretary, 240 Middle Road, Santa Barbara, California.

**CALIFORNIA COUNCIL OF ARCHITECTS**

Vincent Palmer, President; Andrew Hass, Vice-President; A. C. Martin, Jr., Secretary-Treasurer; 369 Pine St., San Francisco 4.

**Southern California Chapter:**

Adrian Wilson, President; A. C. Martin, Jr., Vice President; Walter L. Reichardt, Secretary; George E. Gable, Treasurer; Chapter Headquarters, 3757 Wilshire Blvd., Los Angeles 5, California.

**Spokane Chapter (Washington):**

Noel E. Thomson, President; Kenneth D. Stormont, Secretary, Hutton Building, Spokane, Washington.

**Utah Chapter:**

George Cannon Young, President; Theodore R. Pope, Secretary, 29 South State Street, Salt Lake City 1, Utah.

**Washington State Chapter:**

George W. Stoddard, President; Stephen H. Richardson, Secretary, 516 Central Bank Building, Seattle 4, Washington.

**Hawaii Chapter:**

Kenneth W. Roehrig, President; James Morrison, Secretary, 334 Federal Bldg., Honolulu, T. H.

**STUDENTS' CHURCH  
ARCHITECTURAL COMPETITION**

An open competition for students in architecture in American schools and colleges is being conducted by the International Bureau of Architecture, the Church Architectural Guild of America and the Christian Herald.

Awards include four cash prizes and six honorable mentions. Complete information is available from Elbert M. Conover, Dr. Interdenominational Bureau of Architecture, 297 4th Ave., N. Y.

**JEFFERSON NATIONAL  
EXPANSION MEMORIAL**

An open Two-stage Architectural Competition is to be held under auspices of the Jefferson National Expansion Memorial Association, according to a recent announcement by that organization, with headquarters in St. Louis, Missouri.

Object of the competition is to select an architect to be recommended to the Department of the Interior for ultimate employment as designer of the Jefferson National Expansion Memorial.

The Memorial is to commemorate and bring alive again the great act of statesmanship of Thomas Jefferson, the Louisiana Purchase, which initiated the rise to greatness of the young Republic, and the westward surge, in action and thought, of the pioneers who achieved this greatness.

George Howe, Fellow of the American Institute of Architects, has been retained by the Association as Professional Adviser to prepare the program and supervise the conduct of the Competition. The approval of the American Institute of

Architects has been secured.

Through the vision of private individuals and organizations of St. Louis one hundred and twenty-five thousand dollars have been donated, on this national occasion, for compensation and prizes to be awarded to successful competitors.

The Memorial is to stand on the site of Old St. Louis, an area containing more than eighty acres of land, on the bank of the Mississippi adjacent to the present downtown business and shipping districts. The land has been acquired and cleared by the United States Government, under the provisions of the Historic Sites and Buildings Act, with the assistance of the City of St. Louis. The area is under the administrative control of the National Park Service.

The Competition is to be held in two stages. Participation in the first stage will be open to all architects who are citizens of the United States of America. Participation in the second stage will be limited to five competitors selected by the Jury of Award in the first stage. The identities of contestants, whether successful or unsuccessful, will be disclosed only at the conclusion of the second stage.

No prequalification of candidates as to professional standing will be required beyond summary evidence that the competitor is entitled, either by education or experience, to consider himself an architect. Advanced students in architecture will be eligible. If, on the disclosure of his name, the winning competitor is not, in the estimation of the Jury of Award, found to be qualified to carry the

(See Page 39)

# WITH THE ENGINEERS

Structural Engineers Association of Northern California

William W. Moore, President; John A. Blume, Vice President; Franklin P. Ulrich, Sec.-Treas.; Offices 214 Old Mint Bldg., San Francisco, Phone GARfield 3890. DIRECTORS, Mark Falk, M. V. Pregnoft, and R. D. Dewell.

American Society of Civil Engineers San Francisco Section

Theodore P. Dresser, Jr., President; Leon H. Nishikian and Sidney T. Harding, Vice Presidents; John E. Rinne, Secretary-Treasurer; 225 Bush St., San Francisco 20.

Puget Sound Engineering Council (Washington)

R. E. Kister, A. I. E. E., Chairman; E. R. McMillan, A. S. C. E., Vice Chairman; L. B. Cooper, A. S. M. E., Secretary; A. E. Nicholson, I. E. S., Treasurer; Offices, L. B. Cooper, c/o University of Washington, Seattle 5, Washington.

## AMERICAN SOCIETY OF CIVIL ENGINEERS SAN FRANCISCO SECTION

Members heard a talk at their April bi-monthly meeting on the technical phases of "Engineering in Latin America" by Harold B. Gotaas, MASCE. Gotaas, professor of Sanitary Engineering, University of California at Berkeley, was formerly

chief engineer, and later president, of the Institute of Inter-American Affairs and thus spoke from a wide personal experience with engineering problems of the South American countries.

On May 1st a special meeting will be held at the Berkeley Women's City Club, Berkeley, California, for the purpose of hearing E. M. Hastings, president, ASCE, speak on "Society Affairs". Members of the Society, Juniors and Student Chapter members are urged to attend.

\* \* \*

F. E. Bonner, chairman of the Section's Legislative Committee and chairman of the Joint Legislative Committee representing San Francisco, Los Angeles, San Diego, and Sacramento Sections ASCE; Structural Engineers Association of Northern and Southern California; the Consulting Engineers Association County Surveyors Association of California; and the San Diego Engineers' Club, reports some 75 bills have been introduced in the California Legislature affecting engineers and engineer activities.

\* \* \*

Byron L. Nishkian spoke before the Junior Forum in April on the subject "Proposed Bay Land Crossing". Lawrence Lane was chairman.

\* \* \*

Edward A. Reinke, California State Department of Health, recently spoke before members of the Stanford Student Chapter on the subject: "The History of Sanitation."

\* \* \*

Melville Aubrey has been named president of the California Student Chapter for 1947. Other officers include: Oliver Northrup, vice president, Stuart Bartholomew, treasurer, and Arthur Brandow, secretary.

## THE STRUCTURAL ENGINEERS ASSOCIATION OF SOUTHERN CALIFORNIA

Col. Jack Singleton, Chief Engineer of the American Institute of Steel Construction, Inc., was introduced to the 122 members and guests in attendance by C. M. Corbit, Jr., the Institute's newly-appointed representative in this district, at the April meeting.

In his talk, Col. Singleton outlined the aims and activities of his organization. He told of the progress made toward standardization in the construction industry through wide acceptance of A.I.S.C. Specifications For The Design, Fabrication and Erection of Structural Steel for Buildings. Many research projects striving to improve design and practice are instigated and sponsored by the Institute.

The results of recent important experimental tests are being felt now as evidenced by the awareness of engineers of the importance of a revised conception of the fire-retardant properties required

# F.H.A. LOANS

TO BUY—  
REMODEL—  
REFINANCE

Long-term and low-cost F. H. A. loans are available to finance the purchase of homes already built, and to aid in the construction of new homes. Monthly payment F. H. A. loans on existing homes may be arranged for periods ranging up to 20 years. F. H. A. loans up to \$5400 on new construction may be made for as long as 25 years.

*For further information  
call at our Real Estate  
Loan Department*

## CROCKER FIRST NATIONAL BANK

SAN FRANCISCO • OAKLAND  
*California's Oldest National Bank*

*Member Federal Deposit Insurance Corporation*

of a structure. According to Col. Singleton better methods of fireproofing than those we have been employing are coming into use which will result in lighter framework, more economical costs and will therefore be more attractive to those with investment capital.

His remarks on the development of new ideas for connections were received with interest. Specifically, the use of bolts in place of rivets was recommended for transmitting lateral forces from beams to columns. When this is done, fewer bolts than rivets are required but the diameter of the bolts should be considerably greater.

Following his talk, Col. Singleton called for an open discussion and from the large number and variety of questions asked it was apparent that much constructive thinking is going on in the industry.

### STRUCTURAL ENGINEERS ASSOCIATION OF CENTRAL CALIFORNIA

Colonel Jack Singleton, Chief Engineer, American Institute of Steel Construction, Inc., with headquarters in New York, was in Northern California recently conferring with architects and engineers. He spoke before a joint meeting of the Sacramento Section, American Society of Civil Engineers and the newly formed Structural Engineers Association of Central California. His topic was "Recent Developments in Structural Engineering Design."

Colonel Singleton predicted many improvements in fabricated structural steel in both design and construction which will be of material help to engineers and contractors.

### STRUCTURAL ENGINEERS ASSOCIATION OF SAN FRANCISCO

Precast concrete was discussed in detail at the April meeting of the Structural Engineers Association at the Engineers Club. Principal speaker was Willard Ashton, of the Otto Buehner firm in Salt Lake City.

He discussed the development of ornamental concrete work to supplant use of cut stone, and showed samples of Mo-Sai's various color and texture finishes.

"We believe that it offers to the engineers and architects a new field of design," he declared. "It can give a larger scale in the field in which he works and also a variety of colors."

The architectural slab is lightweight in comparison to stone, and more economical to ship, he said. Its function is not confined to new construction, but it is also valuable as a facing for remodeling jobs. It is adaptable to interior work as well as exterior.

Technical slides were shown depicting various stages in the manufacture of slabs, and showing

# The builder who thinks of tomorrow



## Plans for built-in telephone outlets now

One sure way to provide for your clients' comfort and convenience for years to come is to plan for built-in telephone outlets before construction starts.

Here's why.

The location of the telephone can be changed, or additional telephones added without drilling through the flooring or running wires along baseboards.



The convenience of well-placed telephone outlets will be appreciated year after year.

And, built-in telephone outlets add little to building costs . . . much to building value.



Call or dial your local Telephone Business Office. Ask for Architects and Builders Service.

## The Pacific Telephone and Telegraph Co.





**IMMEDIATE DELIVERY  
WOOD TRUSSES**

Strong, durable American trusses. Available for immediate delivery. Give span, spacing, load, and number required.

**25 years experience**



For full information, write . . .

**AMERICAN ROOF TRUSS COMPANY**  
228 WEST SANTA BARBARA AVENUE  
Los Angeles, California  
ADams 1-4379

**No More Worry  
on this Job...  
THREE HINGES.**

**STANLEY**  
Trade Mark  
THE STANLEY WORKS, NEW BRITAIN, CONNECTICUT

VISIBLE  
Mark of Good  
Construction



outstanding examples of their decorative value.

William C. Tait, general contractor, spoke briefly on precast concrete, and introduced E. W. Dienhart, Chicago, executive secretary of the National Concrete Masonry Association. He outlined growth of the industry.

Wm. Gray, of Haydite Products Company of San Francisco, spoke briefly. A. G. Streblov of Basalt Rock Co. of Napa; Frank Steigerwalt, of Haydite Products Co. of San Rafael, and Tom Mullen of Permanent Cement, also spoke.

**U. C. EXTENSION  
ENGINEERING**

A special 18-meeting course in engineering system solutions by operational methods was started by the Extension Engineering department of the University of California recently in Los Angeles.

Benedict Cassen, Research Physicist with the U. S. Navy Ordinance Test Station, will serve as instructor. Prerequisites to the course which is held Wednesdays at 7:00 p.m., include mathematics through differential equations, A. C. theory and analytical mechanics.

**E. J. STUBER APPOINTED**

Mr. E. J. Stuber, prior to the beginning of World War II associated with the Bethlehem Steel Company in the Metallurgical Department at the Lackawanna Plant, has been appointed Contracting Engineer of the Fabricated Steel Construction Division of the Bethlehem Pacific Coast Steel Corporation with offices in Alameda.

He served as lieutenant in the U. S. Navy Inspection of Navy Materials and in the Contract Termination Section during the War.

**ELECTED PRESIDENT**

W. B. Pierce of Pittsburgh, Pa., was elected president of the American Society of Tool Engineers at a board of director's meeting of society held in Houston, Texas, on March 21.

He succeeds A. M. Sargent of Detroit.

Other officers elected were I. F. Holland, Hartford, Conn., first vice president; R. B. Douglas, Montreal Quebec, Canada, second vice president; George C. Johnson, Rockford, Ill., third vice president; W. A. Dawson, Hamilton, Ontario, Canada, secretary; and V. H. Ericson, reelected executive secretary.

**FRANKLIN INSTITUTE AWARDS**

Everett G. Ackart, recently retired chief engineer of the E. I. du Pont de Nemours Company has been awarded the Newcomen medal "in consideration of his long and successful career of forty years, in designing industrial steam plants and his outstanding accomplishment in designing and build-



ing a number of these for the manufacture of smokeless powder."

The Clark medal will be awarded to Edward G. Boyer, manager at the Philadelphia Electric Company's gas department "in consideration of his notable improvements in the development of processes for reforming hydrocarbon gases."

And to Dr. George C. Southworth of the Bell Telephone Laboratories will go the Ballantine medal "in consideration of his pioneer work in electromagnetic and microwave technique."

Awards were made at the annual Medal Day ceremonies at the Institute in Philadelphia on April 16.

**PERSONALITY PLUS**

According to a recent survey conducted by the American Society of Mechanical Engineers among 174 employers of engineers, 104 replied to the question "What are the basis on which engineering employees are selected" that "personality" was the first consideration.

The amount of "salary requested" rated last of nine considerations while "scholastic record" came second.

Replies to the questionnaire represent 19 fields of industry employing a total of 2,000,000 persons of whom 40,000 are engineers, according to E. G. Bailey, chairman of the committee.

**EDUCATIONAL CONFERENCE AT COLLEGE OF PACIFIC**

A lengthy educational conference was held at the College of the Pacific at Stockton, California, recently, sponsored by the Lumber Merchants' Association of Northern California.

The conference embraced a number of subjects grouped under product, business, construction and estimating. Among the stressed subjects were commercial lumber properties, mill work, wood shingles, paints and finishes, hardware, business law, estimating and pricing.

Representing the Clay Brick Manufacturers Association of Northern California, and members of the Technical Information Committee of the Producers' Council, C. W. Kraft, president of Kraftite Company of Niles; R. H. Brown, manager architectural products division of Gladding, McBean & Company; and George E. Solnar, manager of the association, spoke before the conference.

**REBUILDING BONDS**

Pacific Grove, Calif., in Monterey county, will soon hold a bond election to decide whether or not to proceed with the \$300,000 high school for which plans have been drawn. The projected building will replace the original high school, which was burned some time ago.

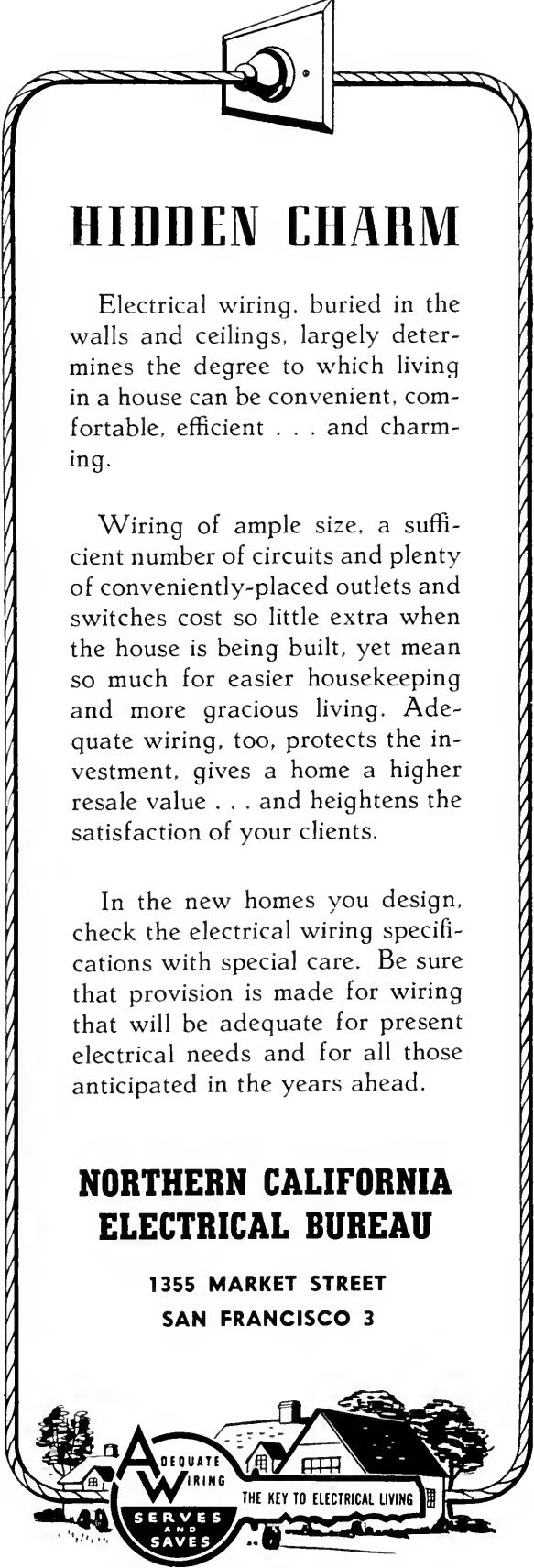

**HIDDEN CHARM**

Electrical wiring, buried in the walls and ceilings, largely determines the degree to which living in a house can be convenient, comfortable, efficient . . . and charming.

Wiring of ample size, a sufficient number of circuits and plenty of conveniently-placed outlets and switches cost so little extra when the house is being built, yet mean so much for easier housekeeping and more gracious living. Adequate wiring, too, protects the investment, gives a home a higher resale value . . . and heightens the satisfaction of your clients.

In the new homes you design, check the electrical wiring specifications with special care. Be sure that provision is made for wiring that will be adequate for present electrical needs and for all those anticipated in the years ahead.

**NORTHERN CALIFORNIA ELECTRICAL BUREAU**

**1355 MARKET STREET  
SAN FRANCISCO 3**

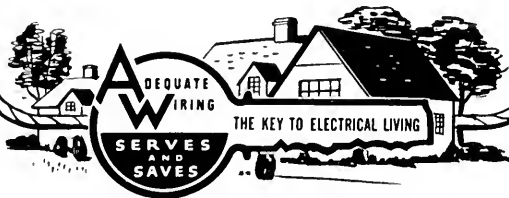

# HEADLINE NEWS & VIEWS

By E. H. W.

Indications are that the peak in construction costs has been reached throughout the Nation with the exception of the Pacific Coast where added rises in building costs are anticipated.

"New construction materials and methods submitted to the Federal Housing Administration for engineering tests indicate long forward strides are just ahead in residential building efficiency and economy."—Raymond M. Foley, NH Administrator and FHA Commissioner.

"Where seven to nine months, or more, were required to complete the average dwelling unit last year, the time has been shortened to four and five months."—Tyles S. Rogers, Producers' Council president.

One of the Pacific Coasts newest industries is the WOOD FIBER DIVISION of the SIMPSON LOGGING COMPANY, Shelton, Washington—dealing in Insulation Board and Roof Insulation through dealers in eleven Western States.

"Architecture is an art and not a science."—Ernest J. Kump, speaking before the Princeton Bicentennial Conference on Planning Man's Physical Environment.

The American Institute of Architects has come out with a BULLETIN. Vol 1, No. 1, is truly representative of the profession represented by the A.I.A., and the publication fills a definite industry need.

The "Train of Tomorrow" nearing completion in the shops of the Electro-Motive division of General Motors, will give American travelers a glimpse of future railroading—the new train will be on exhibit this summer.

Architects of California have entered "the Battle of Sacramento" with a legislative program—casualties in battle are not limited to one side! Legislative battles are no exception.

"MODULAR GRID LINES" is the title of a new pamphlet being issued by the Modular Service Association of Boston, Mass., under contract sponsorship of the office of Technical Services, Industrial Research & Development Division, Department of Commerce.



**PRESSURE TREATED LUMBER**  
**● PROTECTS AGAINST DECAY**  
**AND TERMITE ATTACK**

*Specify it in your home*  
*Available through Lumber Dealers*  
**LOS ANGELES**                      **SAN FRANCISCO**  
 601 W. 5th Street                      333 Montgomery Street  
 Phone Michigan 6294                      Phone DOuglas 3883

*J.H. Baxter & Co.*

AGENTS FOR WEST COAST WOOD PRESERVING CO. SEATTLE, WASH.



**LOS ANGELES**

Branch Offices

HOLLYWOOD	SIERRA MADRE	UPLAND
PASADENA	TEMPLE CITY	LA VERNE
LONG BEACH	WHITTIER	SAN PEDRO
RIVERSIDE	ONTARIO	INDIO

**OAKLAND**  
**SAN FRANCISCO**

## IN THE NEWS

### CAFETERIA

Architects Daniel, Mann & John, Santa Maria, have had preliminary drawings approved for the construction of a cafeteria building for the Santa Maria Union High School. It will contain approximately 10,000 square feet of floor space, and the estimated cost without equipment is \$120,000.

### ESCALATORS

C. J. Hopkinson, Sacramento contractor, was awarded the contract for construction of new escalators for the Weinstock-Lubin department store in Sacramento. Estimated cost, \$200,000.

### PUMPING PLANT

Stolte, Inc., of San Leandro, California, have been awarded the contract for construction of a new \$154,497 sewage pumping plant for the City of Mill Valley.

### HOSPITAL

John A. Lund, Contractor, Turlock (California) has been awarded contract for construction of an addition to the Lillian Collins Hospital to cost \$95,000. Russell G. deLappe, Berkeley, Architect.

### EXPANSION

The TEC Pencil Company, manufacturers of a special line of pencils for architects and draftsmen, is expanding its Western operations through its distributor, Carl Draper & Associates, of Los Angeles, it was announced recently.

### MEDICAL REMODEL

H. Kingford Jones of San Jose, architect for the remodeling of the office building at 123 S. 3rd St., San Jose, into a medical building, has completed the taking of bids on the project.

### TECHNICAL TRAINING

Responsibility for a major part of engineering technician training lies with the junior colleges, Professor E. E. Ericson, head of industrial education at the University of California's Santa Barbara campus, stated recently.



## Speaking of **BRANDS**

• Here in the West there's one brand that represents the finest in lighting equipment. The SMOOT-HOLMAN label on your fixture means certified quality... made in the West... for western use... for western delivery. It's a brand you can depend on.

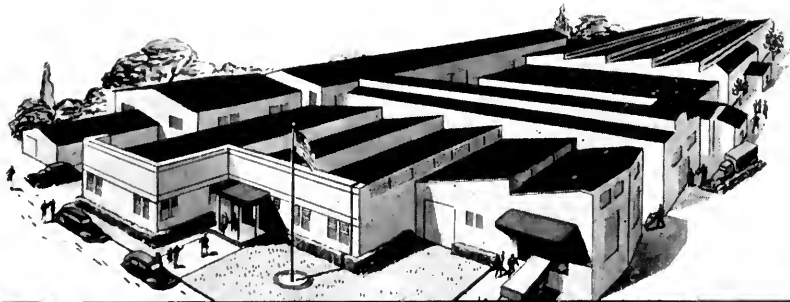

## SMOOT-HOLMAN COMPANY

INGLEWOOD, CALIFORNIA

Offices in Principal Western Cities • Branch and Warehouse in San Francisco



**DIVISIONAL PARTITIONS**—Contain Pleasing Designs in Glass

#### Feeling of Openness

White's whole design in Rucker-Fuller's is to give a feeling of openness—but yet the whole is pulled together by visual means and by ease of circulation. The entrance to the corridor, for example, which serves the executive offices, is accented by a curved wall faced with a hardwood veneer natural finish to complement the office

(See Page 40)

#### LETTERING SPECIALISTS



**RUCKER - FULLER**

Since 1887

*Swan*  
**THE PAINTER**

Phone MArket 1511  
1117 Howard Street, San Francisco

#### Modern Wood Letter Signs

for

**RUCKER - FULLER**

by

**CALIFORNIA WOOD  
CARVING CO.**

1123 Howard Street, San Francisco  
Phone UNderhill 5540

# MILLWORK

Throughout the new

## Rucker-Fuller Store

San Francisco, California

FURNISHED BY

# HOLLENBECK-BUSH PLANING MILL CO.

FRESNO, CALIFORNIA

## A.I.A. ACTIVITIES

(From Page 31)

design and the supervision of construction of the project to completion, he will be required to associate himself with a qualified architect, subject to the approval of the Professional Adviser and the Association, before he is recommended as architect for the undertaking.

As the program will call for landscape design, as well as sketch studies of sculpture and painting, architects are encouraged, though not required, to associate themselves with landscape architects, sculptors, and painters in the preparation of their submissions. Every associate will be given full credit by name, in all publicity, for his contribution to a winning submission and, in the case of the First-Prize winner, will be recommended along with the architect for ultimate employment by the Department of the Interior in executing the design.

On completion of the first stage each of the five competitors selected by the Jury of Award to participate in the second stage will receive the sum of \$10,000 as compensation for (1) the outright transfer of ownership to the Association of his first and second-stage submissions, together with any ideas they may contain, which shall become the property of the Association, to use or dispose of as it may see fit; and (2) the costs incident to participation in the second stage. Each competitor will obligate himself by the acceptance of the stipulated compensation to complete the second stage of the Competition.

At the judgment of the second-stage submissions the Jury of Award will select a First-Prize winner, who will be recommended for employment as Architect of the Project, as stated above, and Second and Third-Prize winners. The prizes are to be as follows:

First Prize .....	\$40,000
Second Prize .....	20,000
Third Prize .....	10,000

The two runners-up will receive \$2,500 each as an honorarium.

Application blanks will be distributed at once in response to all requests of architects who declare their intention to participate in the competition by sending their names and addresses to:

George Howe, Professional Adviser  
The Jefferson National Expansion  
Memorial Competition  
Old Courthouse  
415 Market Street  
St. Louis 2, Missouri

The program will be mailed starting June 1, 1947. The names of the members of the Jury of Award will be announced before the distribution of the

program. Submissions in the first stage must be shipped to the Professional Adviser not later than Monday, September 1, 1947.

### STARLITE ROOF

The special article featuring the Hotel Sir Francis Drake new Starlite Roof, appearing in Architect & Engineer last month, inadvertently omitted stating that Mr. Frank Ehrenthal was the designer, he then being associated with The Walter M. Ballard Corporation.

### SWIMMING POOL

The city of Stockton, California, is building a 75'x165' reinforced concrete, tile top, swimming pool estimated to cost \$75,000.

## FORDERER CORNICE WORKS

*Manufacturers of*

Hollow Metal Products • Interior Metal Trim  
Elevator Fronts and Cabs  
Metal Plaster Accessories • Sanitary Metal Base  
Flat and Roll Metal Screens  
Metal Cabinets • Commercial Refrigerators

**269 POTRERO AVE.**

**SAN FRANCISCO, CALIF.**

**HEMLOCK 4100**

## STRUCTURAL STEEL

**For Class A Buildings,  
Bridges, etc.**

**JUDSON PACIFIC - MURPHY CORP.**

2300 EASTSHORE HIGHWAY  
EMERYVILLE, CALIF.

# SISALKRAFT

REG. U. S. PAT. OFF.

*"More than a building paper"*

**THE SISALKRAFT CO.**

205 West Wacker Drive  
Chicago, Ill.

55 New Montgomery Street  
San Francisco, Calif.



**FLOOR AND CEILING—Contrast with Walls for Display Emphasis**

furniture. A conference room, which would have been uneconomical and used only a few hours every month, is now used as a daily display room. Upon those comparatively few occasions when it is used, it can be curtained off.

Likewise the executive offices are living displays of furniture in proper settings. In one week, for example, three different desks were sold out from under Dale Smith. Customers came in, saw his desk, and asked to have something just like it. They got his desk!

But Architect White is the first to say that his happy effects could not have been obtained by him alone. It had to be owners, company employees and White working together to attain the feeling of integrity which exists in Rucker-Fuller's today. For example, when the need arose for an Information Desk near the entrance, Rucker-Fuller's Artist-designer, Russell Wilson, finished the design for the carpenters. And more than this, during the entire renovation, Rucker-Fuller's employees put up with the solid discomforts of an unheated building in winter, poor lights strung across a bare ceiling, the noise and dust of constant carpentering and the noxious smell of paint. But yet, the employees did so without a single complaint. In Controller Lee Roberts words: "Everyone worked together to give us a building which incorporates a good feeling of unity."

Now after six months' use—enough to shake the wrinkles out of the building—Rucker-Fuller's design for selling has proved itself. Rucker-Fuller's business is better than ever and steadily increasing. Passers-by, with no thought of buying office furniture, walk in to admire the beautiful interior—as did the writer, and before they know it they are shopping for their study or office.

But perhaps more gratifying to Architect Bolton White is the building's reaction upon fellow craftsmen. Hardly a week passes without an architect, designer or interior decorator coming into the building, studying it and taking notes. That's unadulterated tribute!

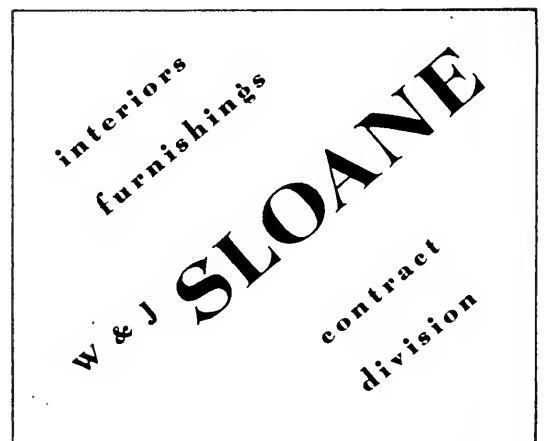

# ESTIMATOR'S GUIDE

## BUILDING AND CONSTRUCTION MATERIALS

PRICES GIVEN ARE FIGURING PRICES AND ARE MADE UP FROM AVERAGE QUOTATIONS FURNISHED BY MATERIAL HOUSES TO SAN FRANCISCO CONTRACTORS. 2½% SALES TAX ON ALL MATERIALS BUT NOT LABOR

All prices and wages quoted are for San Francisco and the Bay District. There may be slight fluctuation of prices in the interior and southern part of the state. Freight cartage, at least, must be added in figuring country work.

**BONDS**—Performance—\$10 per \$1000 of contract. Labor and materials, \$10 per \$1000 of contract.

**BRICKWORK**—

- Common Brick—Per 1M laid—\$80.00 to \$100.00 (according to class of work).
- Face Brick—Per 1M laid—\$150 to \$200 (according to class of work).
- Brick Steps—\$2.30 per lin. ft.
- Brick Veneer on Frame Bldg.—Approx. \$1.50 per sq. ft.
- Common Brick—\$26.00 per M, truckload lots, f.o.b. job.
- Face Brick—\$60 to \$100 per M, truckload lots, delivered.
- Cartage—Approx. \$5.00 per M.

**BUILDING PAPER**—

1 ply per 1000 ft. roll.....	\$5.30
2 ply per 1000 ft. roll.....	7.80
3 ply per 1000 ft. roll.....	9.70
Brownskin, Standard, 500 ft. roll.....	7.00

**BUILDING HARDWARE**—

Sash cord com. No. 7.....	\$2.50 per 100 ft.
Sash cord com. No. 8.....	2.75 per 100 ft.
Sash cord spot No. 7.....	3.50 per 100 ft.
Sash cord spot No. 8.....	3.75 per 100 ft.
Sash weights, cast iron, \$50.00 ton.	
Nails, \$3.42 base.	
Sash weights, \$45.00 per ton.	

**CONCRETE AGGREGATES**—

The following prices net to Contractors unless otherwise shown. Carload lots only.

	Bunker per ton	Del'd per ton
Gravel, all sizes .....	\$2.44	\$2.15
Top Sand .....	2.38	3.13
Concrete Mix .....	2.38	3.06
Crushed Rock, ¼" to ¾" .....	2.38	2.94

	Bunker per ton	Del'd per ton
Crushed Rock, ¾" to 1½" .....	\$2.38	\$3.13
Roofing Gravel .....	2.81	3.50
River Sand .....	2.50	3.06

**Sand**—

Lapis (Nos. 2 & 4).....	3.56	3.94
Olympia (Nos. 1 & 2).....	3.56	3.88

**Cement**—

Common (all brands, paper sacks), carload lots, \$3.02 per bbl. f.o.b. car; delivered \$3.40. Cash discount on carload lots, 10c a bbl., 10th Prox., less than carload lots \$4.00 per bbl. f.o.b. warehouse or delivered. Cash discount 2% on L.C.L.

Atlas White	}	1 to 100 sacks, \$3.13 sack warehouse or del.; \$9.56 bbl. carload lots.
Calaveras White		
Medusa White		

**DAMP-PROOFING and Waterproofing**—

- Two-coat work, \$5.00 per square.
- Membrane waterproofing—4 layers of saturated felt, \$9.00 per square.
- Hot coating work, \$3.00 per square.
- Medusa Waterproofing, \$3.50 per lb. San Francisco Warehouse.
- Tricocel waterproofing.
- (See representative.)

**ELECTRIC WIRING**—\$15 to \$20 per outlet for conduit work (including switches).

Knob and tube average \$6.00 per outlet. (Available only for priority work.)

**ELEVATORS**—

Prices vary according to capacity, speed and type. Consult elevator companies. Average cost of installing a slow speed automatic passenger elevator in small four story apartment building, including entrance doors, about \$8000.00.

**EXCAVATION**—

Sand, \$1.00; clay or shale, \$1.50 per yard. Trucks, \$30 to \$45 per day. Above figures are an average without water. Steam shovel work in large quantities, less; hard material, such as rock, will run considerably more.

**FIRE ESCAPES**—

Ten-foot galvanized iron balcony, with stairs, \$250 installed on new buildings; \$300 on old buildings.

**FLOORS**—

- Composition Floors, such as Magnesite, 50c per square foot.
- Linoflor—2 gages—\$3.00 per sq. yd.
- Mastipave—\$1.50 per sq. yd.
- Battleship Linoleum—available to Army and Navy only—⅓"—\$3.50 sq. yd. ⅓"—\$3.50 sq. yd.
- Terazzo Floors—\$1.50 per sq. ft.
- Terazzo Steps—\$2.50 per lin. ft.
- Mastic Wear Coat—according to type—20c to 35c.

**Hardwood Flooring**—

- Standard Mill grades not available.
- Victory Oak—T & G
  - ⅜ x 2¼"..... \$252.00 per M. plus Cartage
  - ½ x 2"..... \$210.00
  - ½" x 1½"..... 200.00
- Prefinished Standard & Better Oak Flooring
  - ⅜ x 3¼"..... \$265.00 per M. plus Cartage
  - ½ x 2½"..... 237.00 per M. plus Cartage
- Maple Flooring
  - ⅜" T & G Clear \$330.00 per M. plus Ctg.
  - 2nd 305.00 per M. plus Ctg.
  - 3rd 255.00 per M. plus Ctg.
- Floor Layers' Wage, \$1.87½ per hr. (Legal as of Jan. 21, 1946. Given us by Inlaid Floor Co.)

**GLASS**—

- Single Strength Window Glass..... \$ .40 per □ ft.
- Double Strength Window Glass..... .60 per □ ft.
- Plate Glass, under 75 sq. ft..... 1.25 per □ ft.
- Polished Wire Plate Glass..... 2.10 per □ ft.
- Rgh. Wire Glass .....
- Obscure Glass .....
- Glazing of above is additional.
- Glass Blocks.....\$2.75 per □ ft. set in place

**HEATING**—

- Average, \$2.50 to \$3.00 per sq. ft. of radiation, according to conditions.
- Warm air (gravity) average \$64 per register.
- Forced air average \$91 per register.

**INSULATION AND WALLBOARD—**

Insulation—Full thickness 2".....	\$65.00 per M sq. ft.
Insulation—Full thickness 3½".....	\$95.50 per M sq. ft.
Acoustic insulation—Foil-mounted in both sides.....	\$33.50 per M sq. ft.
Asphaboard—4'x6' panel.....	\$9.00 per panel
Wall board—2" thickness.....	\$49.50 per M sq. ft.
Finished Plank.....	\$69.00 per M sq. ft.
Ceiling Titeboard.....	\$69.00 per M sq. ft.

**IRON**—Cost of ornamental iron, cast iron, etc., depends on designs.

**LUMBER—**

No. 1 Common.....	\$90.00 per M
No. 2 Common.....	88.00 per M
Select O. P. Common.....	94.00 per M

**Flooring—**

Per M Delvd.	
V.G.:D.F. B & Btr. 1 x 4 T & G Flooring	\$170.00
"C" and better—all.....	170.00
"D" and better—all.....	170.00
Rwd. Rustic—"A" grade, medium dry.....	150.00
8 to 24 ft.	
"B" grade, medium dry.....	150.00

**Plywood .**

.....15c to 18c per ft.	
Plyscord.....	9/2c per ft.
Plywall.....	9c per ft.
Plyform.....	15c per ft.

**Shingles (Rwd. not available)—**

Red Cedar No. 1—\$13.00 per square; No. 2, \$10.50; No. 3, \$9.00.  
Average cost to lay shingles, \$6.00 per square.  
Cedar Shakes—Tapered: ½" to ¾" x 25"—\$17.00 per square.  
Resawn: ¾" to 1¼" x 25"—\$22.00 per square  
Average cost to lay shakes,—8.00 per square

**MILLWORK—Standard.**

D. F. \$140 per 1000. R. W. Rustic \$150 per 1000 (delivered).  
Double hung box window frames, average with trim, \$10 and up, each.  
Complete door unit, \$14 to \$20.  
Screen doors, \$6.00 to \$8.00 each.  
Patent screen windows. 50c a sq. ft.  
Cases for kitchen pantries seven ft. high, per lineal ft., \$12.00 each.  
Dining room cases, \$12.00 per lineal foot.  
Rough and finish about \$1.00 per sq. ft.  
Labor—Rough carpentry, warehouse heavy framing (average), \$60.00 per M.  
For smaller work average, \$60.00 to \$75.00 per 1000.

**MARBLE—(See Dealers)**

**PAINTING—**

Two-coat work.....	per yard 60c
Three-coat work.....	per yard 80c
Cold water painting.....	per yard 25c
Whitewashing.....	per yard 15c

**PAINTS—**

Two-coat work.....	60c per sq. yd.
Three-coat work.....	80c per sq. yd.
Cold water painting.....	25c per sq. yd.
Whitewashing.....	15c per sq. yd.
Turpentine.....	\$1.85 per gal. in 5-gal. cont.
Raw Linseed Oil.....	\$3.19 per gal. in 5-gal. cont.

**Boiled Linseed**

Oil..... \$2.50 per gal. in drums  
Boiled Linseed Oil—\$2.90 per gal. in 5-gal. containers.  
Replacement Oil—\$2.56 per gal. in drums.  
\$2.56 per gal. in 5-gal. containers.  
Use Replacement Oil..... \$2.69 per gal. in 1 gal. cont.  
A deposit of \$7.50 required on all drums.

**PATENT CHIMNEYS—**

6-inch.....	\$2.00 lineal foot
8-inch.....	2.50 lineal foot
10-inch.....	3.50 lineal foot
12-inch.....	4.50 lineal foot

**PLASTER—**

Neat wall, per ton delivered in S. F. in paper bags, \$17.60.

**PLASTERING (Interior)—**

3 Coats, metal lath and plaster.....	Yard \$3.00
Keene cement on metal lath.....	3.50
Ceilings with ¾ hot roll channels metal lath (lathed only).....	3.00
Ceilings with ¾ hot roll channels metal lath plastered.....	4.50
Single partition ¾ channel lath 1 side (lath only).....	3.00
Single partition ¾ channel lath 2 inches thick plastered.....	8.00
4-inch double partition ¾ channel lath 2 sides (lath only).....	5.75
4-inch double partition ¾ channel lath 2 sides plastered.....	8.75
Thermax single partition; 1" channels; 2¼" overall partition width. Plastered both sides.....	7.50
Thermax double partition; 1" channels; 4¾" overall partition width. Plastered both sides.....	11.00
3 Coats over 1" Thermax nailed to one side wood studs or joists.....	4.50
3 Coats over 1" Thermax suspended to one side wood studs with spring sound isolation clip.....	5.00
Note—Channel lath controlled by limitation orders.	

**PLASTERING (Exterior)—**

2 coats cement finish, brick or concrete wall.....	Yard \$2.50
3 coats cement finish, No. 18 gauge wire mesh.....	3.50
Lime—\$4.00 per bbl. at yard.	
Processed LL Lime—\$4.15 per bbl. at yard.	
Rock or Grip Lath—¾"—30c per sq. yd.	
¾"—29c per sq. yd.	

Composition Stucco—\$4.00 sq. yard (applied).

**PLUMBING—**

From \$150.00 per fixture up, according to grade, quality and runs.

**ROOFING—**

"Standard" tar and gravel, 4 ply—\$11.00 per sq. for 30 sqs. or over.  
Less than 30 sqs. \$14.00 per sq.  
Tile \$40.00 to \$50.00 per square.  
Redwood Shingles, \$15.00 per square in place.  
5/2 #1-16" Cedar Shingles, 4½"  
Exposure.....\$16.50 square

5/8 x 16"—#1 Cedar Shingles, 5" Exposure.....	\$17.00 square
4/2 #1-24" Royal Shingles, 7½" Exposure.....	\$18.25 square
Re-coat with Gravel \$5.50 per sq.	
Asbestos Shingles \$30 to \$60 per sq. laid.	
1/2 x 25" Resawn Cedar Shakes, 10" Exposure.....	\$18.50
3/4 x 25" Resawn Cedar Shakes, 10" Exposure.....	21.00
1 x 25" Resawn Cedar Shakes, 10" Exposure.....	22.00

Above prices are for shakes in place.

**SHEET METAL—**

Windows—Metal, \$2.50 a sq. ft.  
Fire doors (average), including hardware \$2.80 per sq. ft.

**SKYLIGHTS—(not glazed)**

Copper, \$1.25 sq. ft. (flat).  
Galvanized iron, 65c sq. ft. (flat).  
Vented hip skylights 90c sq. ft.

**STEEL—STRUCTURAL—**

Base, delivered, \$3.06 per 100, plus normal extras; or \$300.00 to \$400.00 ton in place. Light truss work higher.

**STEEL REINFORCING—**

\$200.00 ton, set.

**STORE FRONTS (None available).**

**TILE—**

Ceramic Tile Floors—\$1.50 per sq. ft.  
Cove Base—\$1.25 per lin. ft.  
Glazed Tile Wainscot—\$1.50 per sq. ft.  
Asphalt Tile Floor ½" x ½"—\$ .40 per sq. ft.  
Light shades slightly higher.  
Cork Tile—\$1.00 per sq. ft.  
Mosaic Floors—See dealers.  
Lino-Tile—\$1.00 per sq. ft.

**Wall Tile—**

Glazed Terra Cotta Wall Units (single faced) laid in place—approximate prices:  
2 x 6 x 12.....\$1.25 sq. ft.  
4 x 6 x 12.....1.50 sq. ft.  
2 x 8 x 16.....1.45 sq. ft.  
4 x 8 x 16.....1.75 sq. ft.

**VENETIAN BLINDS—**

60c per square foot and up. Installation extra.

**WINDOWS—STEEL—**

50c per square foot, \$5 for ventilators.



# Wood Fiber Newest Insulation Board Product

Newest entry into the insulating board products field in the Pacific Northwest is the Wood Fiber Division of the Simpson Logging Company, which has constructed a modern insulating board plant at Shelton, Washington.

The new mill started production April 1, manufacturing in the first runs insulating building board and roof insulation.

The plant will manufacture a complete line of insulating board products, including building board, plank, lath, sheathing, decorative tileboard and roof insulation. They will be marketed under the brand name of Simpson Insulating Board Products. The full production of the new mill is allocated exclusively to lumber dealers in the eleven western states for western building. Twelve distributors covering the West have been appointed and have received first shipments of the new products for distribution to their dealers.

Simpson will also invade the acoustical tile field with an improved perforated tile. It will be marketed in the eleven western states under the trade name of Simpson Acoustical Tile. Eleven distributor-applicator firms have been named.

The new Simpson insulating board products were developed by the Simpson research laboratory which discovered that the Douglas fir, grown on the 240,000 acre Simpson Tree Farm and other timber holdings in the rain belt of the Olympic mountains in the state of Washington produce an exceedingly long and stout fiber. When properly processed in manufacture, this long fiber results in an insulating board of unusual strength and high thermal value. Douglas fir wood is carefully sorted and all bark or rot is removed before chipping. Simpson Logging Company is the only company now using 100% Douglas fir in the manufacture of insulating board and acoustical tile.

## BUILDING TRADES WAGE (JOB SITES) NORTHERN AND CENTRAL CALIFORNIA

ATTENTION: The following are the PREVAILING hourly rates of compensation as determined by the Wage Adjustment Board, or which have been determined by the United States Department of Labor—Revised to July 1, 1946. Wage scales shown are those being paid and in effect mostly by agreement between employees and their union.

CRAFT	San Francisco	Alameda and Contra Costa	Marin	Vallejo	San Mateo	San Jose	Stockton	Sacramento	Fresno
ASBESTOS WORKERS.....	1.75	1.75	1.75	1.75	1.75	1.75	1.75	1.75	1.75
BRICKLAYERS.....	2.05	2.05	2.05	2.05	2.05	2.05	1.75	2.05	2.00
BRICKLAYERS, HODCARRIERS.....	1.57½	1.57½	1.57½	1.57½	1.57½	1.57½	1.47½	1.15	1.25
CARPENTERS.....	1.75	1.75	1.75	1.75	1.75	1.62½	1.50	1.50	1.50
CEMENT FINISHERS.....	1.75	1.75	1.75	1.75	1.75	1.75	1.75	1.75	1.75
ELECTRICIANS.....	1.87½	1.87½	1.87½	1.70	1.87½	1.87½	1.75	1.82½	1.75
ENGINEERS: MATERIAL HOIST.....	1.60	1.60	1.60	1.60	1.60	1.60	1.60	1.60	1.60
PILE DRIVER.....	2.00	2.00	2.00	2.00	2.00	2.00	2.00	2.00	2.00
STRUCTURAL STEEL.....	2.00	2.00	2.00	2.00	2.00	2.00	2.00	2.00	2.00
GLASS WORKERS.....	1.58½	1.58½	1.58½	1.58½	1.58½	1.21	1.40	1.37½	1.37½
IRONWORKERS: ORNAMENTAL.....	1.85	1.85	1.85	1.85	1.85	1.85	1.85	1.85	1.85
REINF. RODMEN.....	1.75	1.75	1.75	1.75	1.75	1.75	1.75	1.75	1.75
STRUCTURAL.....	2.00	2.00	2.00	2.00	2.00	2.00	2.00	2.00	2.00
LABORERS: BUILDING & CONCRETE.....	1.25	1.25	1.15	1.15	1.15	1.15	1.25	1.25	1.15
LATHERS.....	1.90	1.90	1.60	1.87½	1.75	2.00	1.87½	1.60	1.87½
MARBLE SETTERS.....	1.75	1.75	1.75	1.75	1.75	1.75	1.75	1.75	1.75
MOSAIC & TERRAZZO.....	1.75	1.75	1.75	1.75	1.75	1.75	1.60	1.16	1.12½
PAINTERS.....	1.75	1.75	1.75	1.64	1.75	1.75	1.60	1.60	1.50
PILEDRIERS.....	1.86	1.86	1.86	1.86	1.86	1.86	1.86	1.86	1.86
PLASTERERS.....	2.00	2.00	1.75	2.00	2.05	2.00	2.00	1.87½	1.87½
PLASTERERS' HODCARRIERS.....	1.75	1.75	1.75	1.75	1.75	1.75	1.65	1.40	1.40
PLUMBERS.....	1.87½	1.87½	1.87½	1.87½	1.87½	1.87½	1.87½	1.87½	1.87½
ROOFERS.....	1.50	1.62½	1.50	1.62½	1.25	1.37½	1.50	1.50	1.50
SHEET METAL WORKERS.....	1.75	1.75	1.75	1.75	1.75	1.75	1.75	1.75	1.75
SPRINKLER FITTERS.....	1.58	1.58	1.58	1.58	1.58	1.58	1.58	1.58	1.58
STEAMFITTERS.....	1.87½	1.87½	1.87½	1.87½	1.87½	1.87½	1.87½	1.87½	1.87½
STONESETTERS (MASONS).....	2.05	2.05	2.05	2.05	2.05	2.05	1.75	2.05	2.00
TILESETTERS.....	1.80	1.75	1.75	1.75	1.75	1.75	1.37½	1.37½	1.37½

Prepared and compiled by

CENTRAL CALIFORNIA CHAPTER, ASSOCIATED GENERAL CONTRACTORS OF AMERICA

with the assistance and cooperation of secretaries of Central Contractors Associations and Builders Exchanges of Northern California.

## CLASSIFIED ADVERTISING

RATE: 10c PER WORD . . . CASH WITH ORDER

MINIMUM \$2.50

**ARCHITECT'S REPORTS**—A valuable advance news service giving building and construction information daily on projects in Northern California. Name, location, architect, proposed cost, etc., on individual slips. Ideal for securing new business leads. Hun-

dreds of items, total monthly cost only \$10. Don't delay, subscribe today. ARCHITECT & ENGINEER, Room 618, 68 Post Street, San Francisco, California. Phone DOuglas 8311.

**METAL WINDOWS** (Steel - Aluminum - Bronze). Large Stock, ALL TYPES. STEEL SASH SALES & SERVICE, Weehawken, N. J.

**ENGRAVING**—Good engravings are essential to a satisfactory job of printing reproduction. For the best, see Poor Richard Photo Engraving Co., 324 Commercial St., San Francisco.

## WOOD FIBER PRODUCT

These new developments are a part of the Simpson Company's expansion program in the building material field. Up to the present time, production has been confined to lumber from two sawmills, plywood from two plants, and doors and millwork from one of the largest plants in the industry.

The Wood Fiber plant is under the management of C. J. Macke, a vice president of the Simpson Logging Company. R. E. Seeley, vice president in charge of sales, has supervision over the sales of all company products. A. L. Crozier, who has been with the company for a number of years, most of which have been as Eastern District Representa-

tive with offices in New York City, has been transferred to the main sales office in Seattle as sales manager of the Wood Fiber Division. Sales engineer and technical advisor is Paul D. Close, nationally known authority and technical writer on insulation. Close joined the Simpson organization after serving seven years as technical secretary of the Insulation Board Institute, Chicago.

"I believe our research laboratory and new Wood Fiber Division plant have developed and are manufacturing the finest, strongest insulating board on the market," commented R. E. Seeley, vice president in charge of sales for Simpson Logging Company.

"In production only a short time, the plant has achieved a high uniformity in the product. We are immensely proud of our new plant and of its high-grade insulating board products," continued Seeley.

The new Simpson acoustical tile has a high sound-absorption value due to the Douglas fir fibers and clean, drilled perforations of which there are 484 to the 12"x12" unit. The tile is attractively finished in oyster white, as is the bevel. It is made in two sizes, 12"x12" and 12"x24", and in thicknesses of 1/2", 5/8" and 3/4".

The insulating board products are made in standard sizes and thicknesses; the building board, decorative tileboard and plank are finished one side in oyster white.

Despite the current shortage of insulating board products in the market, a broad and intensive advertising and merchandising campaign is being launched this month. Special emphasis will be placed on point-of-sale material for dealers.

While an old and honored name in the Pacific Northwest, the Simpson Logging Company may be new to some dealers in far corners of the eleven western states. The Simpson Logging Company was organized in 1895, and is one of the oldest and most progressive wood products concerns in the Pacific Northwest. It maintains extensive operations in southwest Washington, with headquarters at Shelton. A continuous and ample source of supply of prime Douglas fir fiber for manufacture of Simpson insulating board products is guaranteed through the operation and maintenance of the Simpson Tree Farm timber holdings in the Olympic mountains. The Tree Farm, as well as other holdings, guarantee a continuous succession of crops of Douglas fir. Trees are grown under intelligent, scientific forest management which includes nurseries for cultivation of seedlings for replanting protection of the forests from fires, insects, disease and fungus.

The new wood fiber plant started production shortly after the Simpson Logging Company executed a 100-year agreement with the U. S. Forest

(See Page 46)

## HOGAN LUMBER CO.

*Wholesale and Retail*

### LUMBER

**MILL WORK • SASH & DOORS**

*Office, Mill, Yard and Docks*

**SECOND AND ALICE STREETS • OAKLAND, CALIF.**

*Telephone GLencourt 6861*

## CLINTON CONSTRUCTION CO. OF CALIFORNIA

### General Contractors

**923 FOLSOM STREET • SAN FRANCISCO**

**SUtter 3440**

## SANTA MARIA INN SANTA MARIA, CALIFORNIA

FRANK J. McCOY, General Manager

FERNAND E. PIMENTEL, Manager

*On the  
Coast  
Highway  
between  
San  
Francisco  
and  
Los  
Angeles*



*American  
or  
European  
Plan  
•  
Old  
English  
Tap  
Room*

## BOOK REVIEWS PAMPHLETS AND CATALOGUES

### NELSON ELECTRIC ARC STUD WELDER. Nelson Sales Corporation, Lorain, Ohio.

A 36-page brochure, describing the application of stud welding in the construction industries. Studs used for securing corrugated asbestos and other types of roofing and siding, metal lath, insulation, and other integral construction materials, to structural steel frames is shown along with types used in installation of mechanical, electrical, and sprinkler equipment.

Copies of the booklet may be obtained from the NELSON SALES CORPN., Lorain, Ohio.

### NEW INDUSTRIAL DIMENSIONS. General Electric Co., Bloomfield, N. J.

A new reference guide in handling material of industrial refrigeration and air conditioning.

Highly illustrated showing uses of industrial refrigeration and air conditioning, with examples of efficient and economical solutions to specific problems shown.

Copies available from GENERAL ELECTRIC CO., Bloomfield, N. J.

### MOISTURE CONDENSATION. University of Illinois, Urbana, Ill.

Circular Series, Index Number F6.2, deals with "The Problem and Cure"; Climatic Danger Zone; Condensation Troubles, Their Evolution; Cures for Condensation; Avoiding Condensation; and Special Problems.

Copies available UNIVERSITY OF ILLINOIS, Small Homes Council, Urbana, Ill.

### NIGHT COOLING—of Industrial Buildings. File No. 20139. Ilg Electric Ventilating Company, Rockford, Ill.

Well illustrated pamphlet showing design for refreshing nighttime air through the home for comfort during heat waves. Copies from HOWARD H. MONK, 500 Brown Bldg., Rockford, Ill.

### SECOND LARGEST APPROVED FHA RENTAL HOUSING PROJECT

Ground has been broken in Seattle, Washington, for the \$5,000,000 FHA rental housing project which will consist of 44 two story buildings containing four, eight and twelve apartments, with 3½, 4, 4½ and 5½ rooms.

Known as the Lake Burien Heights project, war veterans will receive first choice on apartment rentals.

Miller & Ahlson, architects of Seattle, designed the project.

## PACIFIC MANUFACTURING CO.

HIGH CLASS INTERIOR FINISH  
QUALITY MILLWORK

142 SANSOME ST., SAN FRANCISCO  
GARfield 7755

6820 MCKINLEY AVE., LOS ANGELES  
THornwall 4196

BUILDERS EXCHANGE, OAKLAND

## "AMERICAN - MARSH" CONDENSATION UNIT

Pumping  
Machinery  
for  
Every  
Purpose

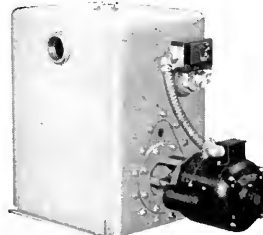

For Service  
Call  
DOuglas  
6794  
or  
MUtual 8322

SIMONDS MACHINERY CO.  
SAN FRANCISCO 816 FOLSOM  
LOS ANGELES 455 EAST 4TH

## VERMONT MARBLE COMPANY

Producers and Finishers  
of  
Domestic and Imported Marbles

525 MARKET STREET, SAN FRANCISCO  
Phone Sutter 6747  
3522 COUNCIL STREET  
(Beverly Blvd. at Virgil Ave.)  
LOS ANGELES 4, CALIF.  
Telephone Fairfax 7834



The Most Complete Line of  
STEELS and BUILDING MATERIALS  
Made by a Single Producer



See Sweet's Catalog File or write us for  
full information.

REPUBLIC STEEL CORPORATION  
GENERAL OFFICES: CLEVELAND, OHIO

DENVER, COLORADO . . . . . CONTINENTAL OIL BUILDING  
LOS ANGELES, CALIFORNIA . . . . . EDISON BUILDING  
SALT LAKE CITY, UTAH . . . . . WALKER BANK BUILDING  
SAN FRANCISCO, CALIFORNIA . . . . . RIALTO BUILDING  
SEATTLE, WASH. . . . . WHITE-HENRY-STUART BUILDING

## WOOD FIBER PRODUCT

(From Page 44)

Service. This 100-year program places the so-called Shelton Working Circle on a sustained yield basis, which in effect assures a theoretical perpetual timber supply. The wood fiber plant ties in logically with the company's sustained yield program. By utilizing every part of the tree to the fullest extent possible, the volume of timber logged will be reduced considerably without reduction in the total quantity of forest products manufactured. This program so far has resulted in increased employment within the Shelton Working Circle, while the actual drain on the timber supply has remained constant.

Sales division of the Wood Fiber Division, Simpson Logging Company, is located at 1010 White Building, Seattle.

The new Simpson insulating board products will be distributed in the eleven western states by the following firms: Arizona Sash, Door & Glass Co., Phoenix and Tucson; California Builders' Supply Co., Oakland, Sacramento and Fresno; Continental Lumber Co., Boise Elliott Bay Lumber Co., Seattle and Everett; Exchange Lumber and Manufacturing Co., Spokane; Frost Hardwood Lumber Co., San Diego; Lumber Dealers, Inc., Denver and Pueblo, Colorado and Billings, Montana; Chas. E. Sand Plywood Co., Portland; Simpson Industries, Inc., Los Angeles, California and Shelton, Washington; Utah Lumber Co., Salt Lake City; Van Arsdale-Harris Co., San Francisco; Western Door & Sash Company, Oakland; California Panel & Veneer Co., Los Angeles.

### BIGGER BANK

The Bank of California will spend \$124,000 on the building of an addition to their bank premises at California and Sansome streets in San Francisco. The general contract has been awarded to Fred J. Early Jr., of San Francisco. Bliss & Fairweather of San Francisco are the architects.

### QUONSET SALES SET RECORD

Sale of Quonset packaged steel buildings by the Kraftile Company of Niles, Calif., exceeded the

million dollar mark in 1946, company president C. W. Kraft, recently announced.

Units purchased by farmers, industrialists and other business firms included Quonsets of 20-foot width, as well as 24's, 40's and multiple arch adaptations of those sizes. The huts are distributed by the Stran-Steel Division of the company.

### RAYMOND P. FLINT APPOINTED FIELD REPRESENTATIVE FOR THE NO. CAL. ELECTRICAL BUREAU



Raymond P. Flint

Raymond P. Flint, well known in the electrical industry here, has been appointed Field Representative of the Northern California Electrical Bureau, with headquarters in the Western Merchandise Mart, San Francisco, according to announcement by John S. C. Ross, Chairman of the Executive Committee of the Bureau.

Flint will take over the activities in the lighting field carried on by the late Clark Baker, and will also assume a leading part in the promotion of the Adequate Wiring program.

Prior to his affiliation with the Northern California Electrical Bureau, Flint was sales engineer for Russell and Company, manufacturers representatives. During the war he was associated with George G. Sharp, Naval architect, as Pacific Coast electrical field engineer. Before the war he was associated with the General Air Conditioning Company.

Initial plans for the Adequate Wiring program, Flint states, include a series of lectures and demonstrations before electrical contractors and other groups in the electrical industry, architects and builders as well as units of the Bureau throughout Northern California.

### HIGH SCHOOL GYM

Hannah & Cline, Oakland architects, have completed drawings for a new frame and stucco high school gymnasium at Parlier, California, to cost \$90,000.

### MENDOCINO HIGH

Bonds have been voted for a new auditorium, library, cafeteria, science and class room high school building at Mendocino, California.

According to C. A. Caulkins, Santa Rosa, Architect the building will cost approximately \$113,000.

## Check those accidents!

Minimize possible damage claims against building owners  
by installing —

### Finlenite Non-Slip Metal Safety Treads

Standard sizes or made to specification  
CHECKERED, FLUTED, OR PLAIN SURFACES

**GUNN CARLE & CO**  
20 POTRERO AVENUE • SAN FRANCISCO, CALIF.

## MULLEN MFG. COMPANY

BANK, STORE AND OFFICE  
FIXTURES—CABINET WORK  
OF GUARANTEED QUALITY  
CHURCH SEATING

Office and Factory:  
60-80 RAUSCH ST., Bet. 7th and 8th Sts.  
San Francisco  
Telephone UNDERhill 5815

## IN THE NEWS

### HARRY CLAY COMPANY

Announcement has been made of the merger of the Adamson Engineering Company, the Adamson Company and the Manufacturer's Engineering Company into the Harry Clay Company of Los Angeles.

The new firm have an extensive program of industrial engineering, architectural program and machine design.



## HERRICK IRON WORKS

STRUCTURAL STEEL  
REINFORCING STEEL

18TH AND CAMPBELL STS.  
OAKLAND, CALIF.  
Phone GLencourt 1767

## THE TORMEY COMPANY

GENERAL PAINTERS  
AND DECORATORS

Phone UNDERhill 1913

563 FULTON STREET  
San Francisco

### CHURCH BUILDING

A CPA permit has been granted for the construction of an educational and recreational building, First Baptist Church, Visalia, California.

Estimated cost \$35,000 according to Donald P. Smith, Architect, of San Francisco.

### MEAT PACKING PLANT

A CPA permit has been granted for the construction of a new \$400,000 meat packing plant in Oakland for the John Morrell Company. The firm of Henschien, Everts & Crombie architects of Chicago, Ill., have been named architects.

### SEWAGE TREATMENT PLANT

Quinton Engineers, Ltd., of Los Angeles have been awarded contract for construction of additions to the Tulare, California, city sewage disposal plant at an estimated cost of \$232,200.

### NEW WESTERN OFFICES

The Lincoln Electric Company of Cleveland, Ohio, manufacturer of electric arc-welding equipment, has announced the opening of two new West Coast offices in Los Angeles and San Francisco.

### PLANT SCIENCE

Moore & Roberts, San Francisco general contractors, submitted the low bid for the building of the University of California Plant Science addition at Davis, Calif.

Electric motors as large as a six-room house and rated at 65,000 horsepower will be constructed at Grand Coulee dam to power pumps for the storage of water.

Phone GARfield 1164

## Thomas B. Hunter

Consulting Engineer

DESIGNER OF HEATING  
AIR CONDITIONING  
VENTILATING AND WIRING  
SYSTEMS, MECHANICAL  
AND ELECTRICAL EQUIP-  
MENT OF BUILDINGS

41 SUTTER STREET  
ROOM 710  
San Francisco California

## Scott Company

HEATING - - PLUMBING - - TILE



243 MINNA STREET  
SAN FRANCISCO  
Phone EXbrook 6741

### NEWSPAPER AND RADIO

Birge M. Clark and Walter Stromquist, Palo Alto architects are working on plans for a new newspaper and radio station building for the Palo Alto Times. Cost estimated at \$150,000.

### EXPOSITION AND HOME SHOW

The second annual Construction Industries Exposition and Home Show will be held in the Pan-Pacific Auditorium in Los Angeles, June 12 to 22nd, according to an announcement by Milton J. Brock, President.

Fine  
ENGRAVINGS



POOR  
RICHARD  
PHOTO ENGRAVING CO  
220-124 COMMERCIAL STREET  
SAN FRANCISCO, CA

## DINWIDDIE CONSTRUCTION COMPANY

## BUILDERS

CROCKER BUILDING  
SAN FRANCISCO

## A. F. MATTOCK CO.

Builders



212 CLARA STREET  
SAN FRANCISCO

## INDEPENDENT IRON WORKS

Steel Buildings  
Service Stations  
Steel Storage Tanks  
Fabricated Plate Work  
Steel & Sheet Metal Products  
Fabricated Structural Steel  
Steel Distributors

Eighth & Pine Sts. Oakland, 7

## George F. Brayer

ELECTRICAL  
CONTRACTOR

166 Seventh Street  
San Francisco

Phone: Market 1761

## PITTSBURGH TESTING LABORATORY

Successors to  
SMITH, EMERY & COMPANY

Testing and Inspecting  
Engineers and Chemists

Structural Materials, Structures  
Equipment, Pipe, Soils.

651 Howard St., San Francisco 5  
EXbrook 1747

## Index to Advertisers

ALADDIN Heating Corp.....	48
AMERICAN Roof Truss Co.....	34
AMERICAN TERRAZZO .....	23
ARCHITECTS Reports .....	*
BASALT Rock Company.....	Back Cover
BAXTER & Company, J. H.....	36
BEACON Electric Co.....	23
BRAYER, Geo. F.....	48
CLASSIFIED Advertising .....	43
CLINTON Construction Company.....	44
CROCKER First National Bank.....	32
DINWIDDIE Construction Company..	47
FORDERER Cornice Works.....	39
FULLER, W. P. Co.....	*
GORDON, Chas. E., Painting .....	22
GUNN, Carle & Company.....	46
HANKS, Inc., Abbot A.....	48
HAWS Drinking Faucet Company.....	2
HERRICK Iron Works.....	47
HOGAN Lumber Company.....	44
HOLLENBECK-BUSH Planing Mill.....	38
HUNT, Robert W., Company.....	48
HUNTER, Thos. B.....	47
INDEPENDENT Iron Works.....	48
JUDSON, Pacific-Murphy Corp.....	39
KRAFTILE Company .....	1
LEADER Electric .....	24
MATTOCK, A. F.....	48
MICHEL & Pfeffer Iron Works.....	Inside Back Cover
MULLEN Mfg. Co.....	24 & 47
NORTHERN California Electrical Bureau .....	35
PACIFIC Coast Aggregates, Inc.....	*
PACIFIC Coast Gas Association.....	*
PACIFIC Elevator Equipment.....	29
PACIFIC Manufacturing Company.....	45
PACIFIC Portland Cement Company..	Inside Front Cover
PACIFIC Telephone & Telegraph Co...	33
PERKINS, B. B., Co.....	29
PITTSBURGH Testing Laboratory.....	48
POOR RICHARD Engraving.....	47
REEDER, L. D., Co.....	23 & 30
REMILLARD-Dandini Co. ....	48
REPUBLIC Steel Corporation.....	45
SANTA Maria Inn.....	44
SCOTT Co.....	30 & 47
SIMONDS Machinery Company.....	45
SIMPSON Logging Co.....	6 & 7
SISALKRAFT Company .....	39
SLOAN, W. & J.....	40
SMOOT-Holman Co. ....	37
SPOTT Electric Co.....	28
STANLEY Works, The.....	34
STOLTE Co.....	27
TAYLOR Co., Halsey W.....	*
TORMEY Company, The.....	47
U. S. BONDS.....	5
VERMONT Marble Company.....	45
WESTERN Asbestos Company.....	*
WOOD, E. K., Lumber Company.....	36

\*Indicates Alternate Months

## Robert W. Hunt Company

ENGINEERS

Inspection • Tests • Consultation

Schools and Other Structures  
Are Built as Designed

When Construction Materials are  
Inspected at point of Manufacture  
and during Erection by

ROBERT W. HUNT COMPANY

Cement, Concrete, Chemical, Metallurgical,  
X-Ray and Physical Laboratories

Chicago • New York • Pittsburgh  
Los Angeles • All Large Cities  
San Francisco, 251 Kearny Street

## REMILLARD-DANDINI Co.

Brick and  
Masonry Products



400 MONTGOMERY STREET  
SAN FRANCISCO, CALIF.

## ALADDIN Heating Corp.

Specializing in  
QUALITY HEATING  
EQUIPMENT

2222 San Pablo Avenue  
OAKLAND  
TWinoaks 1022

## ABBOT A. HANKS, INC. Engineers & Chemists

INSPECTING — TESTING — CONSULTING  
CONCRETE • STEEL • MATERIALS  
CHEMICAL AND TESTING  
LABORATORIES  
• RESEARCH AND INVESTIGATION •

TESTS OF STRUCTURAL MATERIALS  
DESIGN OF CONCRETE MIXES  
SHOP AND ERECTION INSPECTION OF  
STRUCTURES AND EQUIPMENT  
INVESTIGATION OF STRUCTURES  
AND MATERIALS  
TESTS AND INVESTIGATION OF  
FOUNDATION SOILS  
FIRE RESISTANCE AND INSULATION  
TESTS

624 Sacramento Street, San Francisco

# ARCHITECT AND ENGINEER

**APPAREL CITY**

**San Francisco**

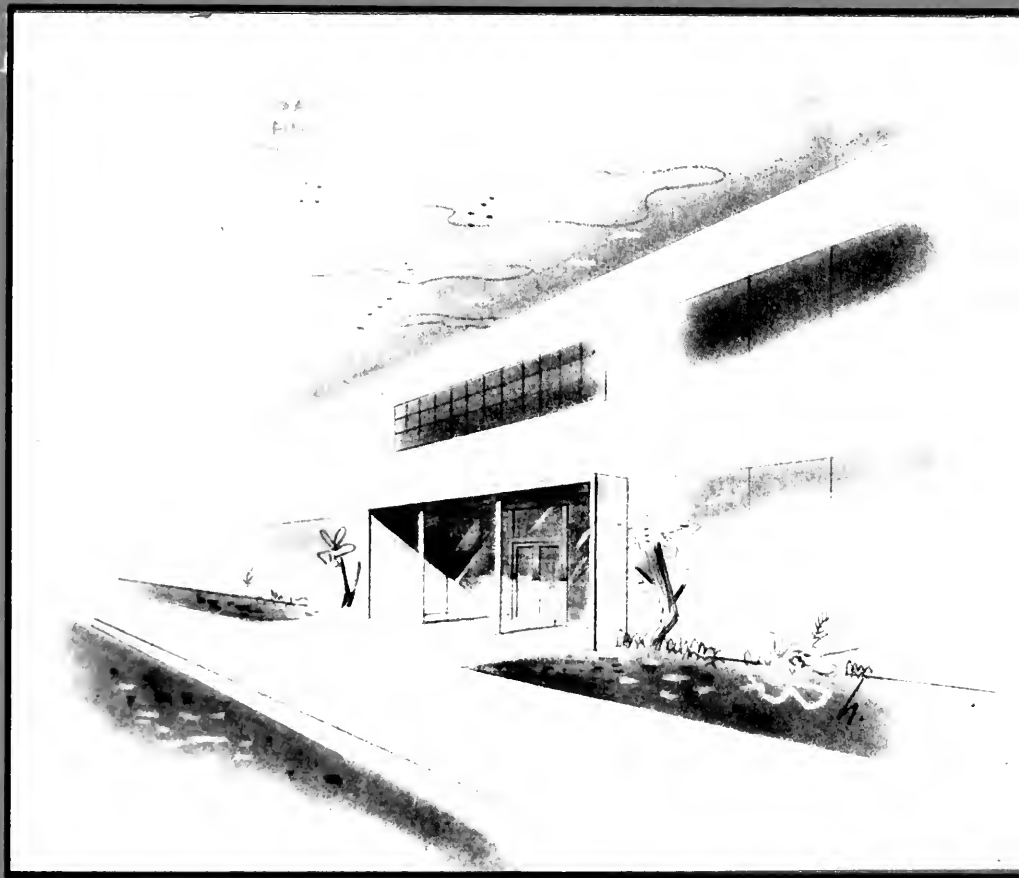

**JUNE**

**1947**

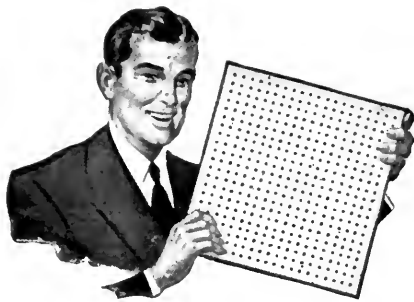

# OVER 1000 YEARS of Combined Acoustical Experience

... At Your Service Through Western Asbestos Co.  
Your Acousti-Celotex Distributor

**M**ORE THAN 1000 years of combined experience, gained in over 100,000 installations—this is the great reservoir of practical knowledge available to you *only* through the Acousti-Celotex\* Distributor Organization of which Western Asbestos Co. is your representative.

This knowledge has been gained in good company. For the nationwide Acousti-Celotex group has collaborated with hundreds of architects in effecting solutions to noise quieting problems.

Every day the men of this organization are helping to solve such problems as:

- How to diagnose acoustical and noise quieting difficulties . . .
- How to reduce distracting noise to a gentle hush . . .
- How to design architecturally for optimum acoustics . . .
- How to be sure of mechanical perfection in the proper acoustical material and its application . . .
- How to make sure of the acoustical installation's perfect appearance and continued satisfactory performance through the years.

*Every man* in this nationwide organization is hand picked. He is thoroughly trained in sound-conditioning practice. As a result, when you turn a job over to him, you know it will be trouble-free.

No matter how much or how little assistance you may need, Western Asbestos Co. is willing and able to help you without obligation. This extra service in no way affects their ability to compete on the smallest or the largest job you may have. That service is the unwritten *plus value* that goes with every specification for Acousti-Celotex.

A phone call or a note will bring a trained sound-conditioning expert to you from Western Asbestos Co.'s staff.

## **WESTERN ASBESTOS CO.**

DISTRIBUTORS • ENGINEERS • CONTRACTORS

SAN FRANCISCO: 675 TOWNSEND STREET, HEMLOCK 4884

OAKLAND: LATHAM SQUARE BUILDING, TEMPLEBAR 7474

SACRAMENTO: 1224 EYE STREET, SACRAMENTO 2-8993

FRESNO: 1837 MERCED STREET, FRESNO 3-3277

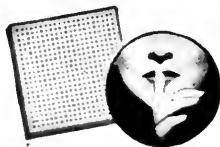

*Sound Conditioning with*  
**ACOUSTI-CELOTEX**

\* Perforated Fibre Tile REG. U.S. PAT. OFF.  
SINCE 1923



# • ARCHITECT

Vol. 169 No. 3

# AND ENGINEER

ARCHITECTS' REPORTS—Published Daily  
Telephone DOuglas 8311

E. H. WILDER  
Editor

MARK DANIELS, A.I.A.  
Associate Editor

JOHN S. BOLLES, A.I.A.  
Book Reviews

MICHAEL GOODMAN  
Post-War Planning

E. N. KIERULFF\*  
Ass't Editor  
\*In the Service

★  
**Contents for**

## JUNE

COVER PICTURE: "APPAREL CITY—San Francisco", Page 21

EDITORIAL NOTES . . . . .	4
REFREGIER'S MURALS, Rincon Annex Post Office, San Francisco By NORA LEE ROHR . . . . .	9
NEWS & COMMENT ON ART . . . . .	14
JAMES W. McALISTER, Chrysler-Plymouth, Burlingame, California By LEO J. SHARPS, A.I.A. Irving S. Brown & Leo J. Sharps, Architects . . . . .	18
SAN FRANCISCO'S APPAREL CITY BECOMING A REALITY . . . . . J. Francis Ward & John S. Bolles, Architects . . . . .	21
SHERMAN CLAY & COMPANY, Oakland, California By THEODORE C. BERNARDI, A.I.A. William W. Wurster, Theodore C. Bernardi & Donn Emmons, A.I.A., Architects . . . . .	24
A.I.A. ACTIVITIES . . . . .	31
WITH THE ENGINEERS . . . . .	32
HEADLINE NEWS & VIEWS . . . . .	36
IN THE NEWS . . . . .	37, 46, 47
ESTIMATOR'S GUIDE, Building and Construction Materials . . . . .	41
BUILDING TRADES WAGE SCALES, Northern and Central California . . . . .	43
CLASSIFIED ADVERTISING . . . . .	43
BOOK REVIEWS, Pamphlets and Catalogues . . . . .	45
INDEX TO ADVERTISERS . . . . .	48

ARCHITECT AND ENGINEER (Established 1905) is published on the 15th of the month by The Architect and Engineer, Inc., 68 Post St., San Francisco 4; Telephone EXbrook 7182. President, K. P. Kierulff; Vice-President and Manager, L. B. Penhorwood; Treasurer, E. N. Kierulff.

Los Angeles Office: Wentworth F. Green, 6605 Hollywood Blvd., Los Angeles 28. Telephone HEMPstead 3171.

Entered as second class matter, November 2, 1905, at the Post Office in San Francisco, California, under the Act of March 3, 1879. Subscriptions United States and Pan America, \$3.00 a year; \$5.00 two years; foreign countries \$5.00 a year; single copy 50c. ARCHITECTS' REPORTS are published daily from this office, Vernon S. Yallop, Manager.



## LITTLE LOGIC

There are probably many valid reasons which could be developed in support of the granting at this time, of CPA permits for the construction of football bleachers and other similar improvements to the athletic property of numerous schools and colleges.

Despite such reasoning, however, there is very little economic logic in building grandstands to the exclusion of much needed residential construction.

Veterans and others who are in dire need of a home should be taken care of first.

\* \* \*

## PROFESSIONAL TRAINING IN ARCHITECTURE

"Preparation for a career in architecture today almost invariably includes training in an architectural school. A little less than eighty years ago the first school of architecture was established in the United States, and others soon followed . . . During the last few decades, the curriculum of the recognized architectural school has been the generally accepted approach to the profession.

"The architectural school endeavors to instruct the student in the principles of his profession. Leaving experience and specialization to the post-college years, it reflects nevertheless quite accurately certain characteristics of modern architectural practice . . . Rapid industrialization and urbanization of the country, expressed architecturally in new types of buildings, new forms in plan organization, and changing techniques of building, have increased the responsibility of the architect.

"While the architect has always been held accountable for public health and safety as regards building, he is also increasingly responsible in a business sense. Whether the client is an individual, a school board, a corporation, or a government agency, there is a definite insistence on economic value in any building project. Modern practice calls for both an intensification and a broadening of architectural education.

". . . the young man entering an office after college must offer his employer facility in handling the tools of a workman in the architectural profession. These tools are:

- Draftsmanship—
- Knowledge of modern construction—
- Acquaintance with materials—
- Architectural design—

"The curricula of recognized schools of archi-

itecture vary in length from four to five years for the bachelor's degree, and certain schools feature graduate work leading to the master's degree. Part of this difference in time required may depend on the amount of professional training, but it is more likely to vary according to the importance given to general education.

". . . There is an increasing belief that at least a measure of general college education should parallel or proceed the technical training, and that as a result the analysis and solution even of design projects in the architectural school itself will be more sound and more broadly creative.

"The schools, individually and as a group through the Association of Collegiate Schools of Architecture, endeavor to provide the initial training which, after college, will be applied and continued in the early years of office experience."—Wells I. Bennett, A.I.A., Dean College of Architecture, University of Michigan, in "Architecture, A Profession and a Career," published by the A.I.A.

\* \* \*

## AIR FORCE DAY

Using the theme "Air Power in Peace Power", the fortieth anniversary of the Army Air Forces will be observed on Friday, August 1, 1947.

\* \* \*

## PUT BLAME WHERE IT BELONGS

We notice that several organizations of national scope, some of which may be gently exposed to the far reaching influences of the Construction Industry, attempt to gain public recognition by frequent charges and counter charges of failure to solve the G. I. Home, priorities, rent ceilings, and other similar problems.

Even financial experts have advanced the thought that recent declines in the Stock Market were due, in part at least, to the failure of the Construction Industry to fulfill its obligation in the matter of substantial increases in building volumes during the first part of 1947.

Rather than all these hoop-do-hoop conversational claims against an industry which has been bound and shackled by bureaucracy for a long, long, time, why isn't it just honestly and frankly admitted that people don't like the idea of paying a substantial bonus for the privilege of building with substitute materials and at premium wages.

\* \* \*

Incidentally an "expert" is merely an ordinary citizen—away from home.

# *Meet the Demand*

**for cool, refreshing, drinking  
water with HAWS Electric Water  
Coolers!**

Specify them for all types of businesses, large and small. The distinctive, modern-designed, all-metal cabinet with the smart stainless steel top harmonizes with any surroundings. HAWS Electric Water Coolers are dependable, economical, silent in operation . . . and amply provide fresh, cool drinking water with complete safety. You can depend upon HAWS! Write today for full information on HAWS Sanitary Fountains and . . .

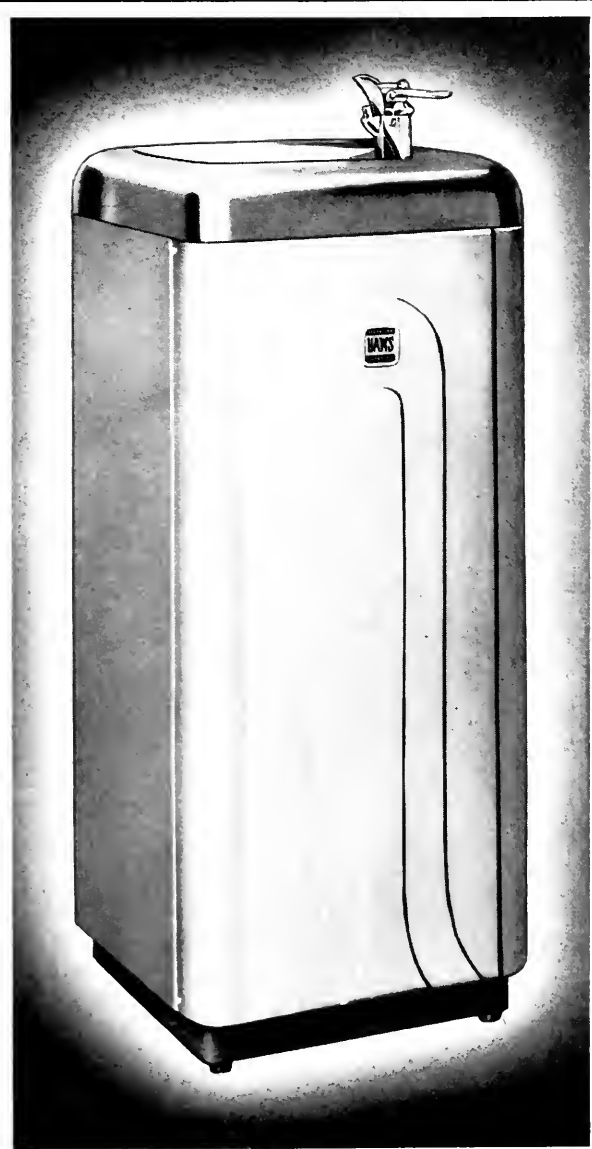

# **HAWS**

**ELECTRIC WATER COOLERS**

**HAWS DRINKING FAUCET CO.**

1808 HARMON STREET (SINCE 1909) BERKELEY 3, CALIFORNIA  
*Agents and Sales Representatives in All Principal Cities*

# NOW!... A Superior Acoustical Tile Made From Incomparable Douglas Fir

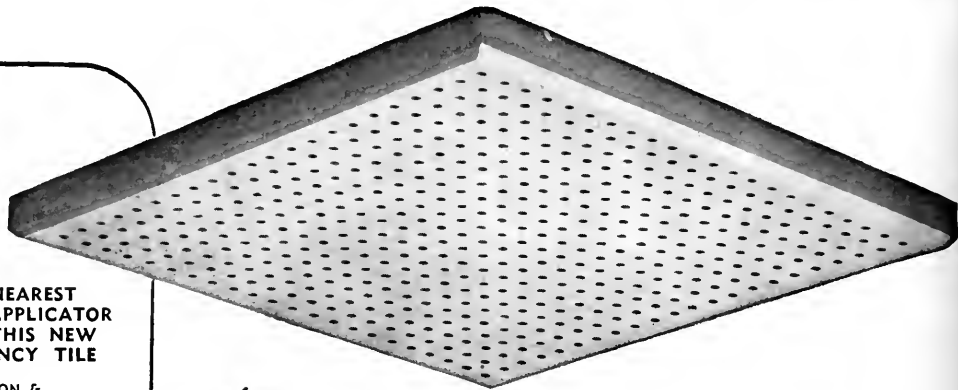

**LET YOUR NEAREST  
DISTRIBUTOR-APPLICATOR  
SHOW YOU THIS NEW  
HIGH-EFFICIENCY TILE**

**ALLIED CONSTRUCTION &  
SPECIALTY CO., INC.**  
8455 Melrose Ave.  
Los Angeles 46, Calif.  
Phone: Walnut 0541

**ANGELES INDUSTRIES**  
984 McGarry St.  
Los Angeles, Calif.  
Phone: Vandike 1783

**ARIZONA SASH, DOOR & GLASS CO.**  
657 West St. Mary's Road  
Tucson, Ariz.  
Phone: 1699

**CONSOLIDATED ROOFING & SUPPLY  
COMPANY**  
520 South 7th Ave.  
Phoenix, Ariz.  
Phone: 47888

**CONTINENTAL LUMBER CO.**  
P. O. Box 2042  
Boise, Idaho  
Phone: 450

**ELLIOTT BAY LUMBER CO.**  
600 W. Spokane St.  
Seattle, Wash.  
Phone: Elliott 8080

**ELLIOTT BAY LUMBER CO.**  
2712 McDougall St.  
Everett, Wash.  
Phone: Main 150

**EXCHANGE LUMBER & MFG. CO.**  
P. O. Box 1514  
Spokane 7, Wash.  
Phone: Glenwood 1621

**FROST HARDWOOD LUMBER CO.**  
327-29 W. Market St.  
San Diego, Calif.  
Phone: F-7224

**LUMBER DEALERS, INC.**  
1301 Wazee St.  
Denver 17, Colo.  
Phone: Tabor 6141

**LUMBER DEALERS, INC.**  
108 South Main St.  
Pueblo, Colo.  
Phone: 4881

**LUMBER DEALERS, INC.**  
423 No. 33rd  
Billings, Mont.  
Phone: 3911

**ROSE CITY FLOOR & INSULATING CO**  
Railway Exchange Building  
Portland, Ore.  
Phone: Atwater 6444

**UTAH LUMBER CO.**  
333 W. 1st So.  
Salt Lake City 9, Utah  
Phone: 4-4318

**VAN ARSDALE-HARRIS CO.**  
595 Fifth St.  
San Francisco 7, Calif.  
Phone: Exbrook 4404



**Simpson**  
QUALITY SINCE 1895

## ACOUSTICAL TILE

HERE, at last, is an improved acoustical tile of superior sound-absorbing properties and decorative beauty. Simpson research, first to take advantage of the long, strong fibers of sturdy Douglas fir, developed a new manufacturing process to create this improved acoustical material. It is produced in a new, modern plant equipped with the latest-design machinery and facilities, employing efficient automatic controls to insure a high degree of uniformity. Simpson Acoustical Tile offers many advantages over similar products. Each 12" by 12" tile has 484 clean-drilled perforations. The tile surface may be painted repeatedly without the perforations clogging or impairing acoustical efficiency. Bevels are finished . . . in the same attractive oyster-white as the surface. Here is added ceiling beauty. Architects . . . ask your nearest Simpson applicator about this new acoustical tile . . . it has a higher degree of efficiency for noise-quieting and acoustical correction.

**WOOD FIBER DIVISION • SIMPSON LOGGING COMPANY**

PLANT AT SHELTON, WASHINGTON. SALES DIVISION, 1010 WHITE BUILDING, SEATTLE 1, WASHINGTON

Also manufacturers of: LUMBER ☆ PLYWOOD ☆ DOORS ☆ CUT STOCK



*How to meet a specific window need - Economically*

**SELECT FROM THE NEW STANDARDIZED FENCRAFT WINDOWS**

**CASEMENT . . . PROJECTED . . . COMBINATION**

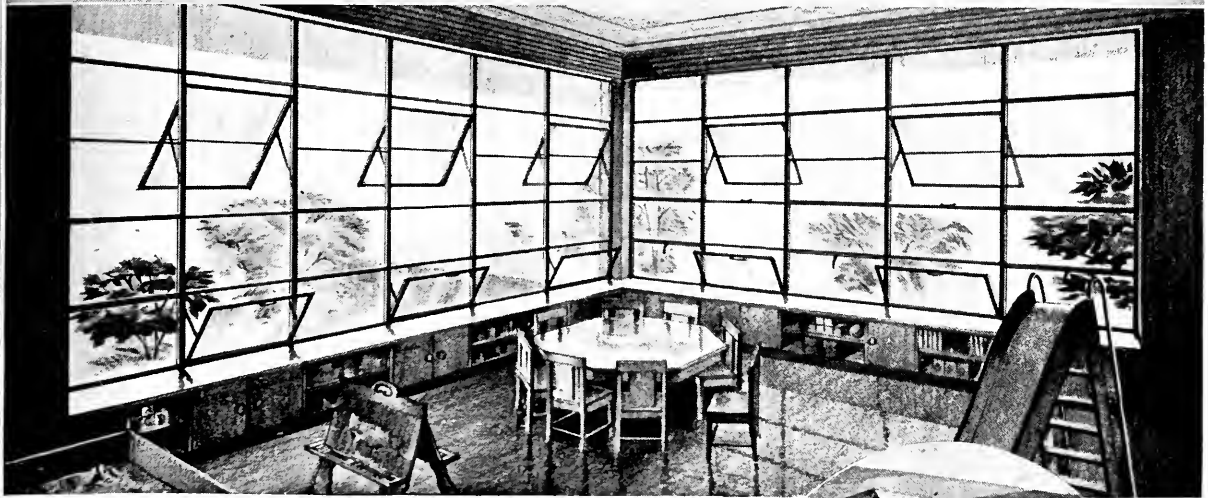

*A* school's kindergarten room, for example, needs ample daylight for young eyes . . . with windows low so youngsters can see out . . . with abundant fresh-air ventilation . . . with all vents so designed that when open the children cannot fall out of windows.

Such windows are offered in the three new lines of Fencraft units which provide new high quality, lower cost and important installation economy.

Built of specially-designed steel casement sections, by craftsmen in the shops of America's oldest and largest steel window manufacturer, all Fencraft Windows beautify both the outside and the inside. They provide permanently easy operation, safe cleaning, lasting weather-tightness, firesafety and low maintenance cost.

For singular economy in cost, all types and sizes are standardized. And installation cost is minimized by the use of uniform installation details, plus the co-ordination of window dimensions with those of wall materials.

Eminently suited for America's finest school buildings, Fencraft Windows are now being shipped to many localities. For product details, mail the coupon below.

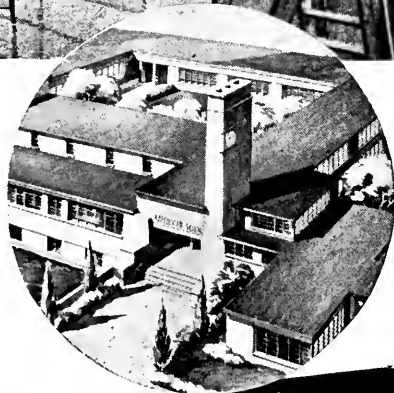

*Suggestion:*

In a school's kindergarten room, combine units of Fencraft Standard Intermediate Projected Windows, such as type 416 (illustrated). Note that sill-vents, opened, guard against drafts, prevent children from falling out.

*Fenestra*



**FENCRAFT INTERMEDIATE STEEL WINDOWS**

Detroit Steel Products Company  
Dept. AE-6  
2262 East Grand Blvd.,  
Detroit 11, Michigan

Please send me data on types and sizes of the new Fencraft family of Fenestra Windows:

Name \_\_\_\_\_

Company \_\_\_\_\_

Address \_\_\_\_\_



**Who else in the West  
can give you such  
near-neighbor service?**

**FULLER  
BRANCHES:**

- ARIZONA**  
Phoenix  
Tucson
- CALIFORNIA**  
Alameda  
Alhambra  
Bakersfield  
Berkeley  
Beverly Hills  
Compton  
Eureka  
Fresno  
Glendale  
Hollywood  
Huntington Park  
Long Beach  
Los Angeles  
Modesto  
Oakland  
Pasadena  
Pomona  
Riverside  
Sacramento  
San Bernardino  
San Diego  
San Francisco  
San Jose  
San Pedro  
Santa Ana  
Santa Barbara  
Santa Monica  
Stockton
- IDAHO**  
Boise
- MONTANA**  
Billings  
Butte  
Missoula
- OREGON**  
Portland
- UTAH**  
Ogden  
Salt Lake City
- WASHINGTON**  
Bellingham  
Seattle  
Spokane  
Tacoma  
Vancouver  
Walla Walla  
Yakima



Definitely West-wide! That's Fuller Service—with 44 branches stocking architectural and maintenance finishes, and with factories and branches so located that, no matter where your job may be you can be sure of getting the Fuller products you've specified—and fast! Yes, you can depend upon the West's oldest and best-equipped (in equipment and technical personnel) makers of architectural and maintenance finishes. W. P. Fuller & Co., San Francisco 19, California.



Photos  
by  
Neal George

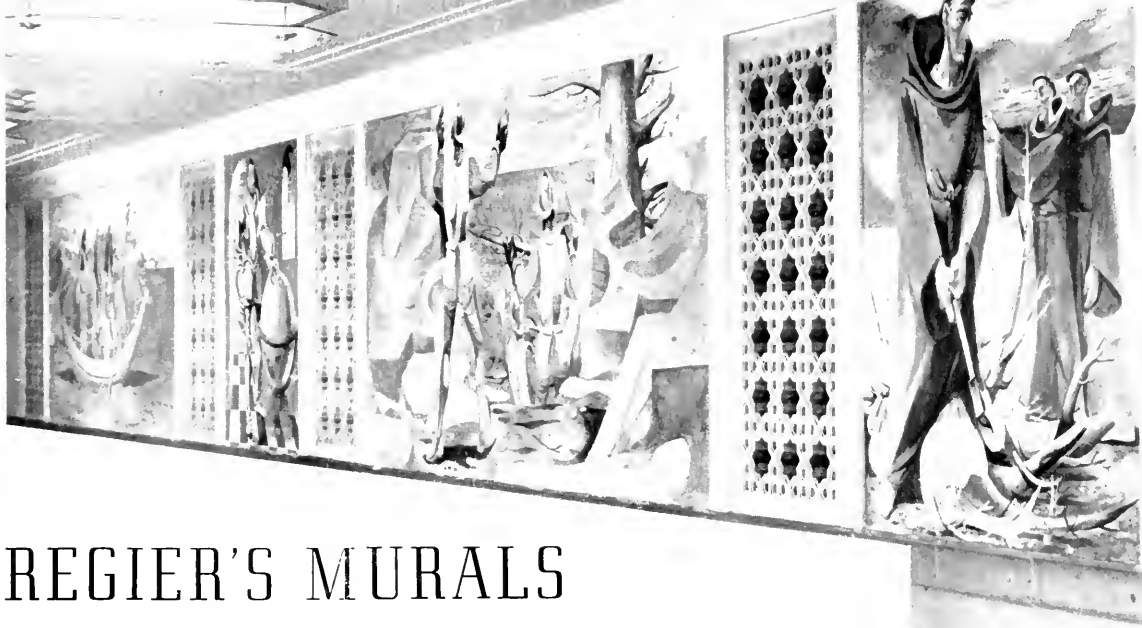

# REFREGIER'S MURALS RINCON ANNEX POST OFFICE Government Sponsorship a Challenge

By NORA LEE ROHR

**The present execution of the government-competition mural at the postoffice gives cause to re-evaluate the importance of mural painting as such, in public buildings, and to consider the desirability of re-establishing a government Fine Arts Section.**

As a survivor of the prewar past the mural points back to one of the most successful forms of government sponsorship of contemporary art and a positive factor in the development of public appreciation of the arts. But it is equally significant in its relationship to the immediate future, as it stands on the threshold of a great architectural era in the United States, an era born of absolute and functional necessity rather than of capitalistic luxury, as has been the case after other wars.

"Prior to the early 'thirties, when the government first began its art program, mural painting was nothing more than decoration in the worst sense of the word, dealing with trite content, using a symbolism borrowed from the Greeks and meaning-

less to this day and age, embellishing this decoration with flowery lines and plenty of gold leaf.

"It is the pioneering that the artists did under government sponsorship that raised mural painting to the level it is at today. And so it will be wholly desirable to continue government sponsorship, which should parallel private commissions," Refregier has declared.

At this point we are faced with two major considerations: the question of government in addition to industrial and private sponsorship—and, the actual utility of mural decoration in relationship to architecture and as an independent form of art. Certainly, the logical sponsorship, where public buildings are concerned, would be that of the government.

To the young artist who is seeking a market for his talent and a manner of presenting his work to the public and critic, no more fertile field exists than mural painting. Under government patronage, in form of nationwide or state competition, as many as 400 to 500 artists were reached and commissioned annually before the war, obviously a much

*EDITOR'S NOTE: The largest mural yet to have been sponsored by the federal government, and to be executed by one artist in a public building, is now in process of completion in San Francisco at the new RINCON ANNEX POST-OFFICE. This mural, designed and executed by Anton Refregier, which has the history of San Francisco for its subject, presents a peculiar history of its own as sole survivor of the Section of Fine Arts of the Public Building Administration, no longer in existence.*

number than can ever profit from private or industrial patronage. Moreover there was no time to spare—ample means were provided for research and experimentation. On the other hand these competitions would serve as a screening (sifting) process by which the best talent receives official recognition, gains experience for the specific problems of mural painting, and can then, in turn, find further outlet in private or industrial enterprise, in form of smaller housing units for private dwellings. Economically then government sponsorship must be recognized as sound in all directions.

Large scale mural painting is also an excellent field for training and apprenticeship in mural painting. Assistants are a matter of necessity in the execution of a mural. The long process of development, from the research on the subject given, to the original sketch for each panel, the scale cartoon, the application to the wall and the final painting is an invaluable form of practical training which can be found in few art schools today.

Finally, mural painting stimulated by government sponsorship would then more readily find application in the planning of smaller units of office buildings, factories or residence-housing, would promote close cooperation and therefore greater understanding of the arts, between client, architect and artist—all of which would profit and learn from such mutual cooperation.

Obviously then mural painting as such serves two major purposes: its close integration with architecture it is part of—since it is not an **organic** but a **decorative part** of the **architecture**, it must **preserve** or even emphasize the **physical character** and the unity of the wall. **As a decorative scheme**, however, it has an unmistakable **life of its own**. A mural painting lodged in a public building, and in a part of the building through which thousands of people may pass daily, can, in its subject matter, transcend its purely decorative quality and serve as a regional, national or even universal language, a vehicle of public education and information. One of the best features of the Rincon Annex mural is that it takes place right in front of the passerby. Every step of the execution can be seen and followed. Craftsmanship can be evaluated on the spot, subject matter can be discussed. Although every panel has had government approval before it is finally applied, public participation remains the most valuable inspiration to an artist like Anton Refregier. Controversy, discussion and personal reminiscences, on the other hand give the public a definite interest and a lasting impression of the mural, which henceforth becomes part and parcel of its daily experience.

Refregier's mural at the Rincon Annex Postoffice succeeds in combining the decorative with the documentary without sacrificing its integrity as a

#### **THE OVERLAND MIGRATION (Top Right)**

**Showing the hardships encountered by the people moving West. This is one of seven large panels alternating with the small ones shown on Pages 12 and 13.**

#### **AFTERMATH OF THE EARTHQUAKE (Center)**

**The soup kitchens—tent colony, trolley-car city—men going to rebuilding job.**

#### **THE EARTHQUAKE AND FIRE (Bottom)**

**April 18, 1906. Both earthquake panels measure seven by eighteen feet and are located on the opposite side of the wall with the grilles.**



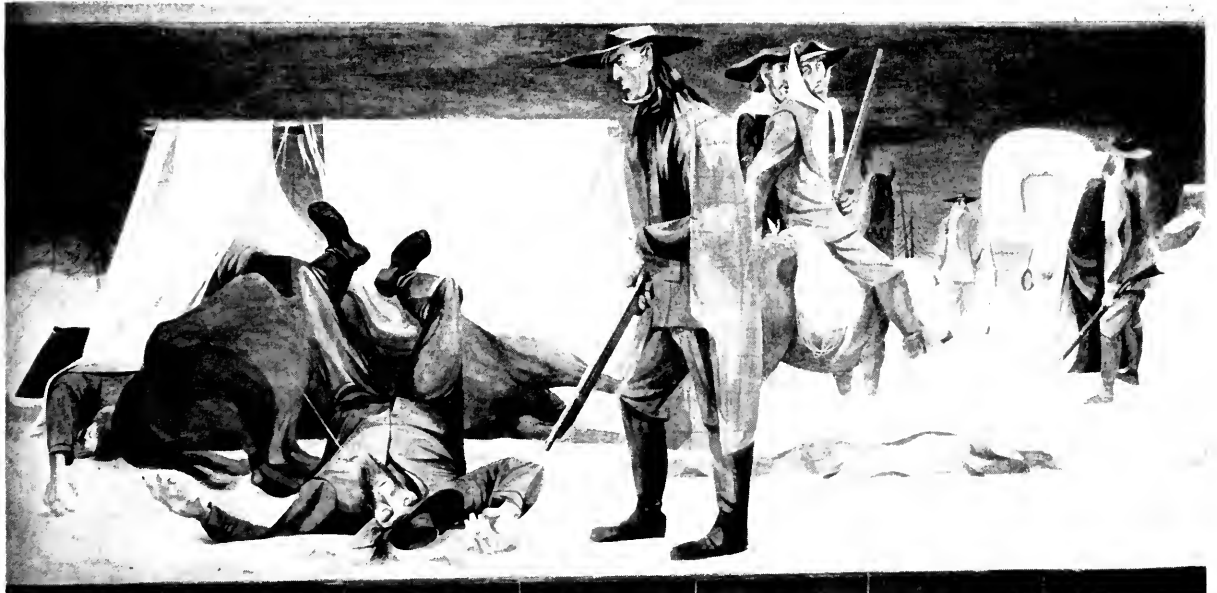



work of art, or rather it is a successful combination of above factors, well knit through a gay but intelligently organized color scheme. The layout of the pictures show the details of the mural plan, its overall design, calculated to pull the whole together into a continuous band on the north and south walls of the corridor. The greatest handicap to the unity of the total mural is the ventilator grill-work which separates each panel on the south wall over the service windows.

To overcome this particular difficulty the artist has designed each of the 13 panels on a basic "half-moon" design. Large simple and harmonious forms, a carefully balanced palette, with a progressively warm and cool colorscheme create a feeling of continuity on this 170' wall which faces a 208' street wall in which the panels are regularly intersected by windows. Beginning with the first discovery of the Bay by the American Indian, and subsequently by Sir Francis Drake and ending with the United Nations Conference in San Francisco in 1945, as the large end wall panel, Mr. Refregier is in the process of presenting to San Francisco two centuries of native history in its highlights, while creating one of the most outstanding mural achievements now in progress.

Having won the mural contract through a government sponsored competition of the Section of Fine Arts in Washington in 1940, Mr. Refregier has been working on preliminary studies for the execution of the work for the past six years. The work is now under the supervision of the Department of

Public Works, the Section of Fine Arts has not yet been re-inaugurated, but it is hoped that this will soon be the case.

Anton Refregier is best known for his murals, but is also interested in easel paintings and is now working on a series of panels which will be the natural outgrowth of his present mural work. Born in Russia the artist has been in this country since 1920. He had his initial art training at the Rhode Island School of Design in Providence, but has spent considerable time studying on his own both here and abroad. In Munich he was a student of Hans Hoffman and in Paris he was apprenticed to a sculptor, some of his work was done for Norman Bel Geddes. He feels that it is essential for a mural painter to have some knowledge of architecture and construction.

His list of murals is impressive, among the most important are: murals in Plainfield Postoffice, N. J.; S.S. Polk, oceanliner; 20th Century Limited; Cafe Society Up-Town, New York; New York World's Fair, 1939-40; Federal Work Agency Building. But he is probably best known for the decoration of Cafe Society Up-Town, in New York, where the whole interior construction is according to his plan. As easel painter he is represented in the Museum of Modern Art, the Metropolitan Museum, Walker Art Center, Museum of the University of Arizona and in the Collection of the Encyclopedia Britannica. While executing his work in San Francisco he is conducting a course in mural painting at the California Labor School.



**ILLUSTRATIONS—**

These six vertical panels alternate with the horizontal ones on the South wall. Left to right:

**FORT ROSS**

**BUILDING OF THE MISSION**

**SIR FRANCIS DRAKE**

**PRINTING OF CALIFORNIA STAR**  
(First San Francisco newspaper)

**ARRIVAL OF THE CLIPPER**

**RAISING OF THE BEAR FLAG**  
(Section only)

and at the right is detailed portion from the panel,  
**"THE OVERLAND MIGRATION"**





BEATRICE WOOD, Hollywood—3 Acrobats, large black pearl bowl (shelf left); LILLIAN KENDALL, Fairfax—Sculptures—"Shore Leave," "St. Francis," and "Gabriel, Lemuel, and David"; M. PURKISS, Fullerton—Decorated bowls and plates; SALLY DE PAOLO, Los Angeles—Bowls (left table); FLORENCE BRUNTJEN, San Francisco—Candle Holders and Bowls (front); NANCY and ROBERT CLOUGH, Oakland—Covered Stoneware Jars and Pitcher; MARY FULLER, Berkeley—Tiny terra cotta head; RALPH TARZIAN, Long Beach—Large flat Oyster bowl and small bowls (shelf right).

*Melger, Photos*

## SIXTH ANNUAL PACIFIC COAST CERAMIC EXHIBITION

The Sixth Annual Pacific Coast Ceramic Exhibition, held in the Rotunda Gallery of the City of Paris, San Francisco, is being sponsored this year by Mr. Paul Verdier.

Object of the exhibition, which was organized six years ago by Beatrice Judd Ryan, director of the Art in Action Shop, is to stimulate artists in production of high standards by bringing together annually the best examples of ceramic sculpture and pottery developed in the West, and to widen the appreciation and interest of the public in ceramics of original design and fine workmanship.

Some seventy-six Ceramic Artists from the West are showing 370 exhibits.

The jury for selecting the work and awards for this year comprised: Laura Anderson, director of Ceramic Department U.C.L.A.; Whitney Atchley, Industrial Designer and director Ceramic Department California School of Fine Arts; Ruth Cravath, Instructor in Sculpture, Dominican College, California School of Fine Arts, and Mills College; Edith Heath, Professional Potter; and Beatrice Judd Ryan, Organizer and Curator.



LIST OF PRIZE WINNERS

Above:—MARY LINDHEIM—San Francisco, 1st Award in Pottery—Liqueur & Casserole Set, tea pot, candy box, vase; CARLTON BALL—Oakland, Honorable Award in Pottery—Black Bottle; ELENA MONTALVO NETHERBY—Oakland, Honorable Award in Pottery—Large Jar; EVE NATHANSON—San Jose, Honorable Award in Pottery—Decorated Bowl; ANTONIO PRIETO—Oakland, Honorable Award in Pottery—Vase with figures; Allied Potters—BARBARA WUEST, TOMMY THOMPSON—San Francisco, Honorable Award in Pottery—Decorated Plate; MARY FULLER (Rubenstein)—Berkeley, 1st Award in Sculpture—African Woman; LILLIAN KENDALL—Fairfax, Honorable

Award in Sculpture—Curtain Call; EUGENIE GERSHOY—San Francisco, Honorable Award in Sculpture—Dancer.

Below:—Pieces chosen for their functional value. CLAUDE HORAN—Lamp Base Top. WHITNEY ATCHLEY—Casserole Top in three pieces—top reversed can be extra plate and base, to protect table from scorching, may be taken off and can be used as an ash tray. WHITNEY ATCHLEY—Breakfast Set—Covered coffee cups can be used as ash trays, plate covers may be used as bowls; EUNICE PRIETO—Fruit Compote or Cocktail Containers; MARY LINDHEIM—Liqueur Set.



**M. H. DE YOUNG MUSEUM  
SAN FRANCISCO**

The schedule of exhibits and activities for the month of June, as announced by Walter Heil, Director, will include the following:

**EXHIBITIONS:** Loan Exhibition of Masterworks by El Greco, through June 22; 4th San Francisco International Exhibition of Photography California Camera Club, opening June 8; Watercolors by Charles B. Rogers, opening June 24; Photographic Abstractions and Fantasies by James Fitzsimmons, opening June 24; Prairie Print Makers, opening June 27; Textiles for You and Your Home, Contemporary Handweavers' Association of California, through June 22; Watercolors of Flowers by Pan-crace Bessa—c.1772—1835 through June; Chinese Lowestoft Porcelian through June.

**PAINTING FOR PLEASURE:** Conducted by Charles Lindstrom. This course of ten weekly sessions aims to help you see more fully and consciously by means of your own practice of the fundamentals of art. It is especially for those, who, though interested in art, think they "can't draw a straight line."

**ART CLASSES FOR CHILDREN:** Conducted by Miriam Lindstrom. The current series of Saturday Classes will end June 21. Four new courses will be offered on week days during the school vacation period as follows: Wednesdays, beginning

July 16, 10:00 to 11:30, Clay modeling (ages 10 to 14); 2:00 to 3:30, Clay modeling (ages 5 to 10); Fridays, beginning July 18, 10:00 to 11:30, Drawing and painting (ages 10 to 14); 2:00 to 3:30, Drawing and painting (ages 5 to 10).

**PAINTING FOR PLEASURE SCHEDULE:** Saturday mornings, 10:15 to noon and Wednesday afternoons, 2:00 to 4:00.

---

**CHI ALPHA KAPPA**

The Architectural Fraternity of the University of California recently held An Exhibition and Sale of Watercolors, in the Oakland Art Museum.

---

**CALIFORNIA PALACE  
OF THE LEGION OF HONOR**

Thomas Carr Howe, Jr., Director, has announced the following schedule of exhibitions and special events for June.

**EXHIBITIONS:** Paintings by Elmer Bischoff, opening June 3; Small Paintings by Calvin Albert, opening June 3; War's Toll of Italian Art, an exhibition arranged by the American Committee for the restoration of Italian monuments, through June.

The Alma de Bretteville Spreckels collection of Sculpture by Auguste Rodin, and the Mildred Anna Williams collection of Paintings, Sculpture, Tapestries and Furniture.

**EDUCATIONAL ACTIVITIES:** No Saturday clas-



**M. H.  
De Young Museum,  
San Francisco**

**"Adoration of the  
Shepherd"**

**Loaned from the  
Metropolitan Museum of Art  
New York City**

ses for Children and adults will be held in June, however, beginning July 1, two special projects for children will be presented.

**SPECIAL PROGRAMS:** Organ recital by Uda Waldrop, every Saturday and Sunday at 3 o'clock. Free Motion pictures each Saturday at 2:30 p.m.

---

### **SAN FRANCISCO MUSEUM OF ART**

The program of exhibitions and activities announced by Dr. Grace McCann Morley for June include:

**EXHIBITIONS:** The Sculpture and Drawings of Henry Moore, June 18 to September 7; Landscapes, Real and Imaginary Museum of Modern Art, June 3 to June 22; and Lipchitz: Prometheus, Bronzes, Photos and 35 drawings June 3 to June 22.

**SATURDAY PAINTERS:** Conducted by Ralph Cornell Seigle outdoors on Saturday afternoons, 1 to 4 p.m., June 14 to August 2. **FILMS,** "Know Your World" Series each Saturday and Sunday 2:30 p.m.

---

### **PORTLAND ART MUSEUM**

The annual Exhibition of the Museum Art School opened May 28th and will continue through June, together with a group show of the Oregon Guild of Painters and Sculptors.

Paintings, life drawings, sculpture, design, printed and woven textiles, and ceramics by the full time students of the day school are exhibited in the Hirsch Wing. Designs by the children of the Saturday classes are hung in the entranceway. Evening classes are represented by chosen examples of work.

The annual Exhibition marks the Museum Art School's thirty-eighth year.

Winners of the Carey Prize for life drawing was awarded to Manuel Izquierdo of Portland (First year scholarship), Mary Ellen Erhardt of Libby, Montana (Second year scholarship), and scholarships for advanced study were awarded to Rose Niguma and Rebecca Rinearson of Portland. Tuition grants were made to Tom Lee, Ida Benjamin and Mary Ellen Binchus.

Three awards are made for merit in life drawing under the Carey Prize. First Prize with \$25 went to George Johanson of Portland, second prize with \$15 was won by Patricia Cottrell from Ogden Utah, and third prize with \$10 by Wesley Baxter of Portland.

### **REVISED STANDARDS ANNOUNCED**

A revised list of 864 approved standards covering definitions of technical terms, specifications for metals and other materials, and methods of test for finished products, was recently announced by the American Standards Association.

The list, which includes many standards developed during the war and now approved for peacetime use, will be made available to interested trade, technical and governmental bodies and individuals without charge, the announcement indicated.

These standards represent agreement on the part of maker, seller, user and regulatory groups as to the best possible practice at the time of approval. They are revised periodically to keep up with mechanical invention, developments of power and new uses for materials.

The list represents the cumulative efforts of about 3000 men, representing 660 organizations.

---

### **UNIVERSITY OF CALIFORNIA HOUSING**

Student housing facilities on the campuses of the University of California have been increased 585 per cent since 1941 at a cost of \$1,225,000, of which 90 per cent came from state funds, E. H. Smith, manager of residence and dining halls, has announced.

At Berkeley, the capacity of dormitory and apartment units has risen from 195 to 1,209; on the Los Angeles campus the increase has been from 110 to 418; at Santa Barbara no such units existed in 1941, and, at the present time, there are facilities for 528; at Davis the rise has been from 160 to 613.

In addition to the housing itself, the University has established new cafeterias at Berkeley and Santa Barbara and has increased the capacity of those on the other campuses, besides establishing transportation systems to serve students living at a distance from the campuses.

---

### **MODERNIZATION SHOW**

Dean Leopold Arnaud, of the Columbia University School of Architecture, will serve on the advisory committee for the first annual Store Modernization Show, scheduled for the Grand Central Palace, New York, during the week of July 7.

Serving with Arnaud are leading figures in American retailing, architects, industrial designers and manufacturers of store equipment in presenting the retail "store of the future."



#### ARCHITECTS

Irving S. Brown

Leo J. Sharps

Burlingame, Calif.

# JAMES W. McALISTER

## CHRYSLER-PLYMOUTH

### BURLINGAME, CALIFORNIA

By **LEO J. SHARPS, A.I.A.**

In planning the new car sales and service building for the James W. McAlister Company of Burlingame, California, architects Irving S. Brown and Leo J. Sharps, gave considerable attention to placing the large sales room in a position to give the most display possible on a difficult lot.

To do this, full advantage was taken of the direction of the street in relation to the side lines of the property, and the placing of a court at one side of the building which gave exterior show windows on two sides of the main sales room, as well as excellent display and complete visibility of the



lubrication service department.

The auto service portion of the building was planned with all possible departments for the complete servicing of vehicles with an entrance from the street, and to a side street, and out through a side court.

**Sloping Glass Show Windows**

The sloping plate glass walls of the Sales Room and main display area were decided upon with

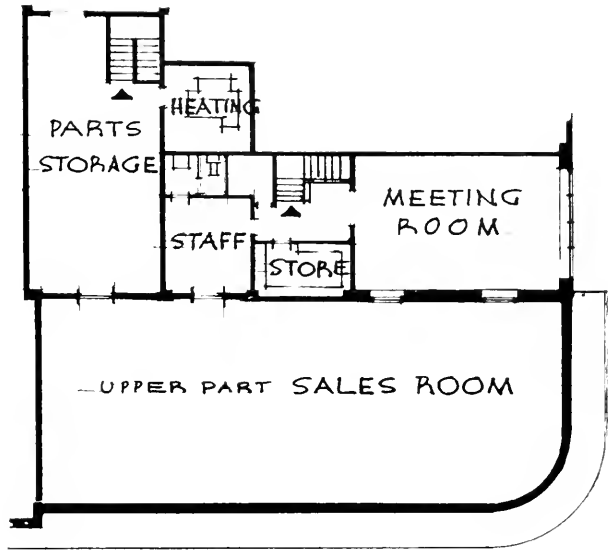

JAMES W. McALISTER  
Chrysler-Plymouth

Architect: Irving S. Brown & Leo J. Sharpes.

Terra Cotta Ceramic Veneer:

Concrete Block Walls: Wm. A. Rainey & Son.

Electrical: Engineering Design Co.

Plumbing and Radiant Panel Heating: Harry Lee.

Heating and Ventilating: Atlas Heating & Ventilating Co., Ltd.

Photos: MacDonald, Young & Nelson, Inc.

some hesitancy, and only after considerable research in order to determine the exact angle of slope which would give maximum visability with a minimum of reflection. It was appreciated that the solution arrived at and adopted would not be a cure-all for reflective distortion of displays on the show room floor. Upon completion of the installation, however, it was quite generally agreed

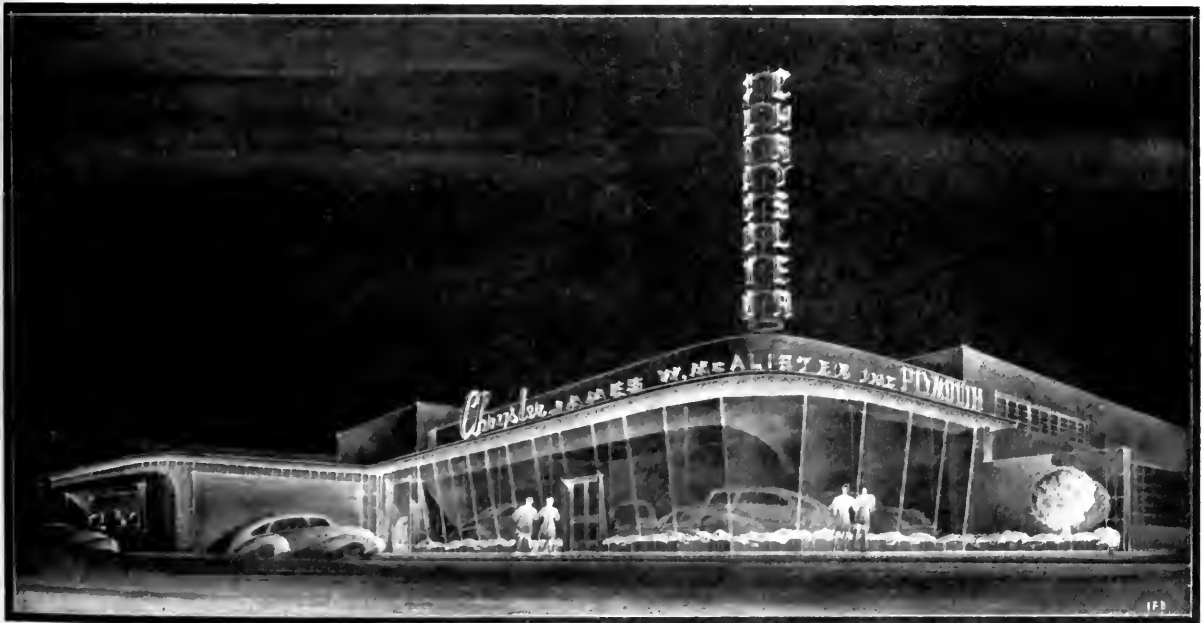

**SLOPING GLASS WALLS OF SHOWROOM OFFER MAXIMUM DISPLAY**

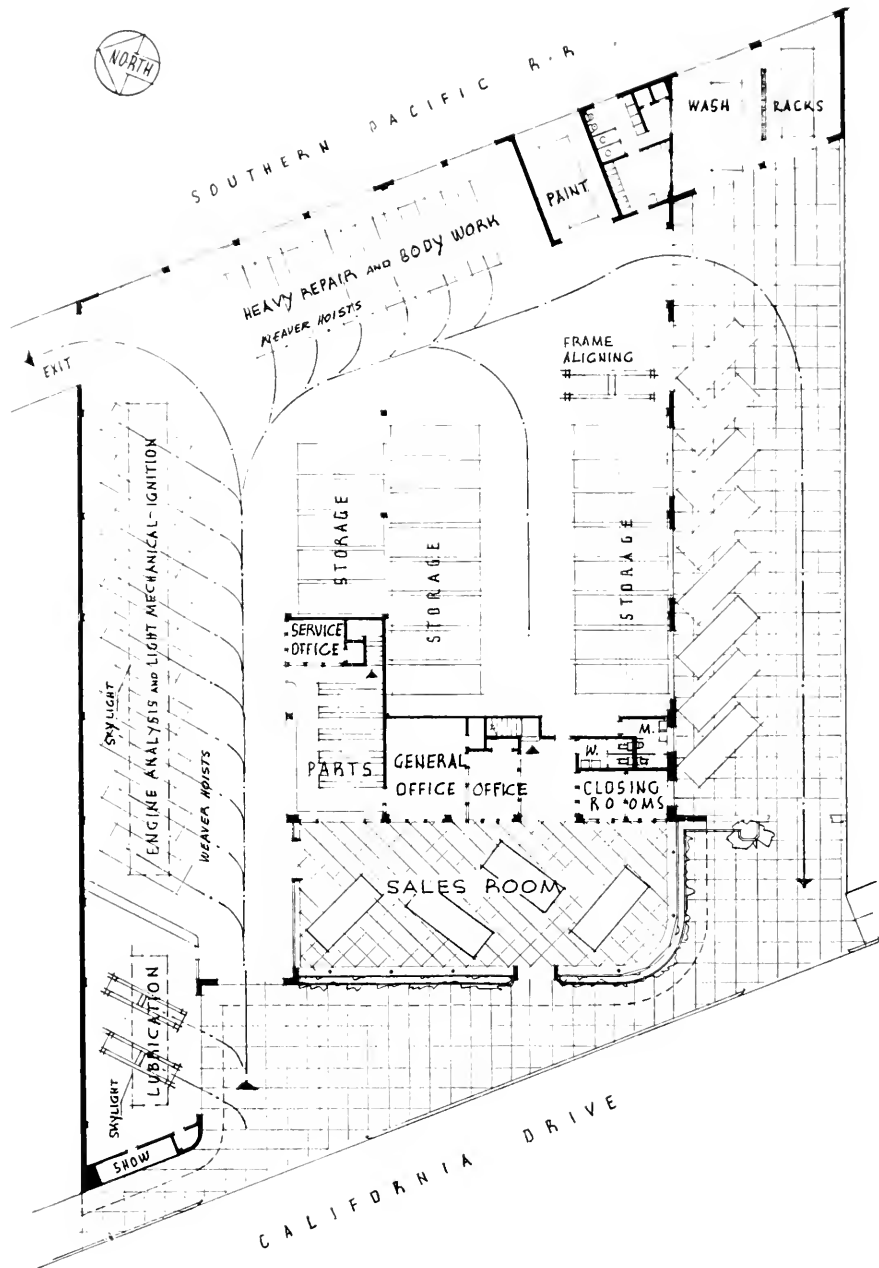

**General Plan of the Entire Plant and Area**

that use of sloping glass was worthwhile as there was a minimum of transposing of moving street reflections above eye level. The spacious paved area in front of the sloping glass was darkened to further aid the visual effect in the lower portions of the windows.

**Panel Heating in Shop**

The problem of providing adequate heating in automobile repair areas with their necessary large open, spacious sections, has always been a great problem, particularly during seasons of the year when outside weather conditions were not ideal.

(See Page 39)

# San Francisco's APPAREL CITY

## Becoming A Reality

**J. Francis Ward and John S. Bolles  
Architects**

Buildings now completed, and those nearing completion, on the new 32-acre Apparel City in San Francisco, are forerunners of a great industry building program which represents the garment manufacturers and representatives on the Pacific Coast.

Apparel City, which is located between Oakdale, Industrial, and Loomis Avenues in the Islais Creek district, is an outstanding example of what can be accomplished when an industry and architects get together at the inception of a project and

plan and work out the final results.

The project represents many individuals and firms, who prior to the development of Apparel City, were operating in all sections of San Francisco and the Bay Area. Some of the activities were centered in buildings not designed for, and never intended to be used by the garment manufacturing industry. Poor light, inadequate ventilation, undesirable employee working conditions, and customer discomfort were paramount in many instances.

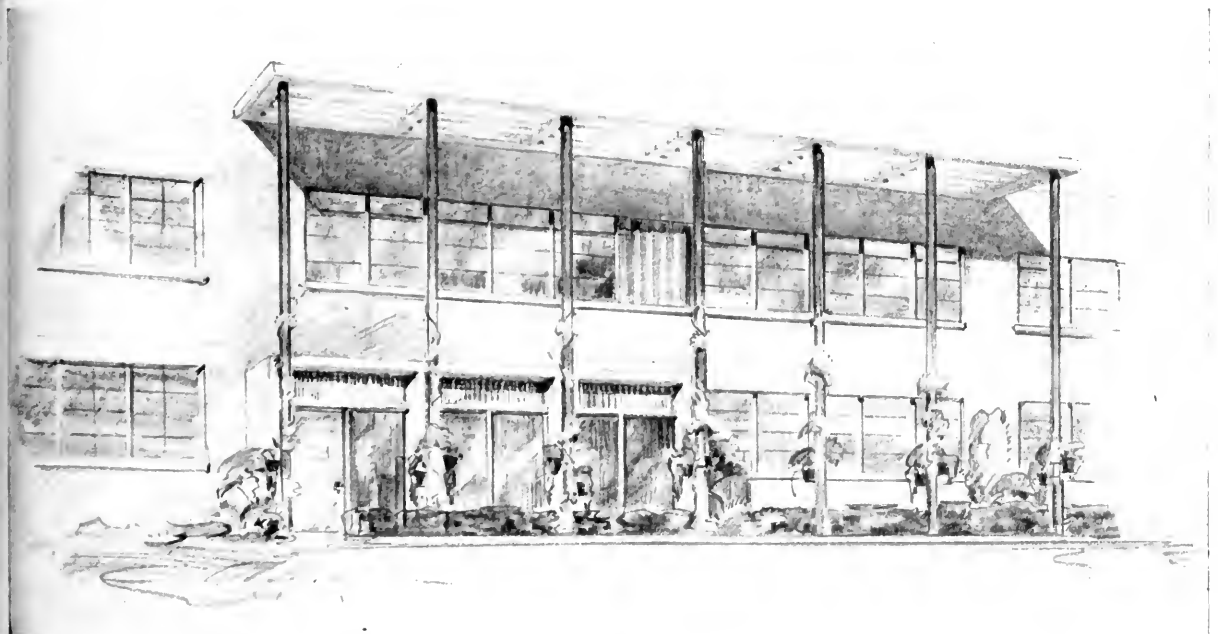

**TYPICAL ENTRANCE—Incorporating Several Unique Features**



**ANOTHER ENTRANCE DESIGN**

**SAN FRANCISCO'S  
APPAREL CITY**

Architect: J. Francis Ward & John S. Bolles,  
A.I.A.

General Contractor: Haas & Rothchild.

Electrical Contractor: Central Electric Com-  
pany, Inc.

Store & Office Fixtures: Portsman's Mill &  
Cabinet Shop.

Electric Installations: Associated Electrical  
& Mechanical Company.

Plumbing, Heating and Air Conditioning:  
Macnsons.

Photos: Allied Photographers.

Led by outstanding men within the industry and encouraged by government officials the Apparel City corporation was formed and services of architects and technical assistants secured.

Plans were immediately drafted by J. Francis Ward and John S. Bolles, Architects, calling for varied possibilities in individual front arrangements within the framework of long one-story buildings, 100 feet in depth and so designed that they would fit the limitations of the ground areas.

Normally, an Architect is faced with the problem of providing maximum space within a limited well-defined area. In this case, the Architects, while not over-endowed with space in which to work, had to strike a careful balance between the economic cost of construction of space within the structures and an appealing amount of open air and landscaping. In order to provide the approximate million feet of floor area required, this will take almost two miles of building. These have

**RIGHT:** Structural steel workers place large steel beams in proper location as the forms for concrete walls go up around them.

**BELOW:** With all "forms" in place, concrete is "poured"—and another one of the new San Francisco Apparel City buildings will soon be completed.



(See Page 30)

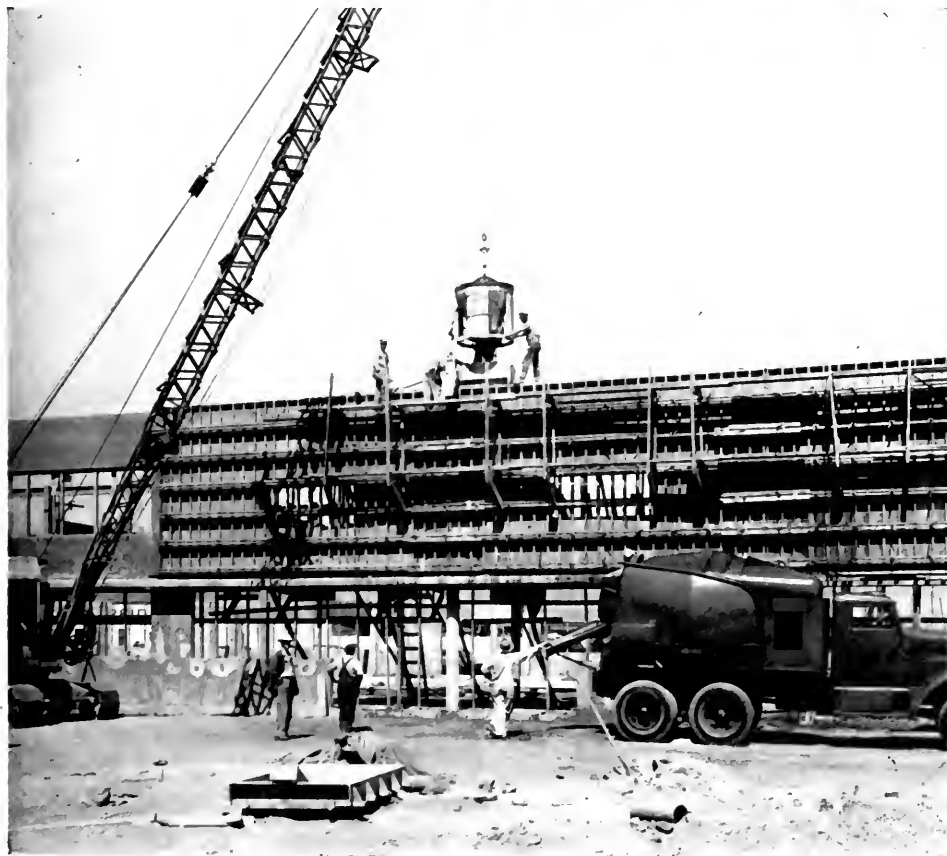



WILLIAM W. WURSTER, THEODORE C. BERNARDI & DONN EMMONS, Architects

# SHERMAN CLAY AND COMPANY — BUILDING Oakland, California

By THEODORE C. BERNARDI, A.I.A.

This new, ultra modern steel and concrete building for the firm of Sherman Clay & Company, which has been in the retail music store business in the San Francisco Bay area since 1887, was designed to meet the needs of the city of Oakland and surrounding communities.

It is built on an irregular lot: One side makes an obtuse angle at the street corner. Three stories were required for the needs of the company, the first two floors were designed to care for the sales and display of merchandise, while the third floor is used for offices, recital rooms, repair shops, and storage space.

The building is unusual in that the owner and the architects worked out a plan to avoid the usual basement storage and repair shop plan, and these activities have been delegated to the third floor where better lighting and a more pleasant environment for employees exists.

The general design of the building was dictated by the stores requirements as to disposition of areas and departments, by budget, and by specialized musical requirements. The interior design is coherent and definite in its use of colors, ceiling heights at two levels, and the play of one area against another.

**RIGHT: Wooden forms in place and re-  
inforced steel laid ready for pouring of  
concrete.**

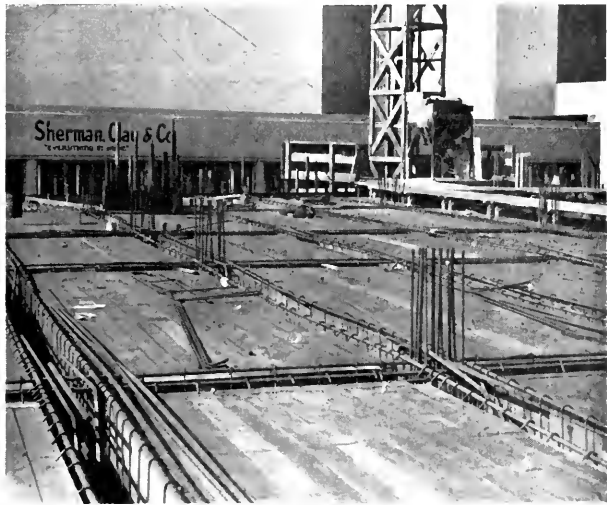

**BELOW: BUILDING WITH WALLS PARTIALLY COMPLETED**



The exterior is distinctive in its groupings of windows into large units. The high polished finish on the exterior aluminum awnings and trim contrasts with the texture of the natural-finished concrete walls.

### Structural Materials

The exterior walls are of exposed concrete, waterproofed with clear waterproofing which retains the natural look of the concrete, and they have a smooth ground finish. Other concrete was poured against plywood forms.

The windows are of clear glass with light and the direct sun being tempered in the interior by use of Venetian blinds.

All of the exterior trim, including the parapet-cap, window frames, sash, awning box covering, marquee facing, wood frame facing above show windows, panels on concrete, are all of aluminum with **alumilited** finish. This aluminum material reduces maintenance to a minimum, and with the **alumilited** finish, no discoloration occurs on the metal. Dust and dirt can easily be removed by washing or wiping with clear water.

Show window bulkheads are of black terrazzo, a serviceable material which is easily maintained.

Glass block panels at stairway landings were used principally for bright, cheerful light, free from glare, without the use of Venetian blinds, curtains or other material in the stair areas.

Other exterior metal, not of aluminum, has a finish of aluminum paint which ties in both with aluminum metal and exposed concrete.

Entrance doors are of clear tempered glass which makes it possible to use the store interior as a display area visible from the street.

Exterior awnings, protecting the Show Windows, are of slotted, inter-locking aluminum. This is a durable awning and one in which the fire hazard has been eliminated.

### Interior

All floors are of concrete, covered with rubber tile, asphalt tile or carpet.

Walls are of painted plaster and of plate glass.

SHERMAN CLAY & CO.  
Oakland, Calif.

Architect: William W. Wurster, Theodore C. Bernardi & Donn Emmons, A.I.A.

General Contractor: Cahill Bros.

Masonry & Glass Blocks: George W. Reed.

Plastering: William Makin.

Awnings: Aluminium Awning Co.

Structural Steel: Judson, Pacific-Murphy, Corp.

Air Conditioning: Aladdin Heating Corp'n.

Photos: Thomas M. Livingstone.



INTERIOR LIGHTING . . . BRINGS OUT DISPLAYS





**MODERN**—Store fixtures, indirect lighting, and interior walls all contribute to delight of store's patrons.

Ceilings are of acoustical plaster.

All of the wood interior doors have a finish of lacquer over black stain. This eliminates the appearance of dirty hand-and-finger-marks sometimes found on painted doors.

The counters are of oak, with natural lacquer finish to retain the oak color.

Display Cabinets and Shelving are painted or stained black with lacquer-finish, depending on location and amount of use.

All trim is painted, or black stain and lacquer-finish, also depending upon location and amount of use.

**Acoustical Treatment**

All ceilings are of acoustical plaster. However, there was need for special treatment in the Record Listening Rooms, and in the Studios. There the walls are made up of two rows of independent studs, separated by an acoustical blanket, double glass of unequal vibration periods set in felt chan-

nels and supported on rubber gaskets. Doors, equipped with felt, seal tight to thresholds upon closing doors. Plaster is over fiber lath. Ceilings are of acoustical tile.

Lighting Treatment is of three main types:

- (1) Recessed fluorescent fixtures with baffles concealing fluorescent tube.
- (2) Concealed cove lighting, at change in ceiling heights, of fluorescent tube.

**Interior and Exterior**

**PLASTERING**

**Sherman Clay & Co.**

by

**WILLIAM MAKIN**



Quality Plastering • Plain and

Ornamental Waterproof Stucco



2141 LIVINGSTON STREET, OAKLAND, CALIF.

Phone: Andover 2743

**The New AWNINGS Selected by  
Sherman Clay & Co.  
Are ALUMINUM**

—to give a trim, modern appearance  
to their Oakland Store

**"ALUMAROLL"  
Aluminum Awnings**

- Last a "Life-time"
- Will not rust or fade
- Require no up-keep
- Roll up easily

Available in a variety of colors

**ALUMINUM AWNING DISTRIBUTORS, INC.**

744 Harrison St., San Francisco 7 YUkon 6-4075



A MODERN STORE DESIGNED FOR PUBLIC SERVICE

(3) Recessed incandescent lamps with flash glass cover, flush with the ceilings. Show Window lighting, in addition to lights at

head of window, has lights high in window, for full depth of the window area, (similar to theatrical border lights) concealed from sidewalk by baffles (also similar to the theatrical border).

There are exposed Spot and Floodlight Fixtures on the ceiling of the Electrical Appliance Department.

Heating and Ventilating is a forced-air system, with zoned control. Heating of air is by means of steam coils in blowers.

**General Structural Data**

The building is on concrete pile foundations, with all columns, girders, beams, floors, walls and stairs of reinforced concrete.

Roof joists, beams and columns are of wood: the interior partitions are of wood studs, covered with metal lath and plaster, and the ceiling is suspended metal lath and plaster.

**MASONRY CONSTRUCTION**

and

**GLASS BLOCKS**

for

**SHERMAN - CLAY**

A WINNING COMBINATION  
GOOD MATERIAL  
PLUS GOOD WORKMANSHIP

**GEORGE W. REED**

1390 So. Van Ness, San Francisco

**General Contractor**

for the

***Sherman Clay Building***

Oakland, Calif.

**CAHILL BROTHERS**

206 SANSOME STREET

SAN FRANCISCO



**ROUGH INTERIOR:** Showing sturdy reinforcing of floors and concrete pillars for upper floor support.

**STRUCTURAL  
AND  
REINFORCING  
STEEL  
FOR  
Apparel City  
AND  
Sherman Clay & Co.**

BY  
**JUDSON  
PACIFIC - MURPHY  
CORP.**

4300 EASTSHORE HIGHWAY  
EMERYVILLE, CALIFORNIA

Steel for  
Buildings and Bridges

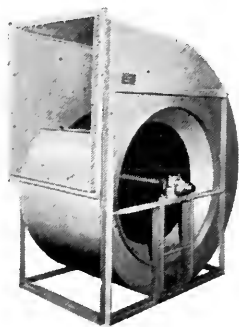

Aladdin Blowers  
provide air handling  
requirements

**ALADDIN AIR HANDLING EQUIPMENT**

used exclusively on the

**NEW SHERMAN CLAY BUILDING**

OAKLAND, CALIF.

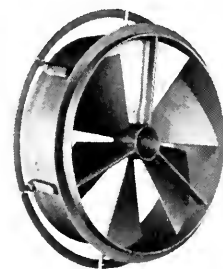

Aladdin Variable Vane  
automatically maintains  
correct air volumes



Aladdin Fuseair ceiling outlets provide proper  
diffusion of air throughout the building.

**ALADDIN HEATING CORPORATION**

OAKLAND

CALIFORNIA

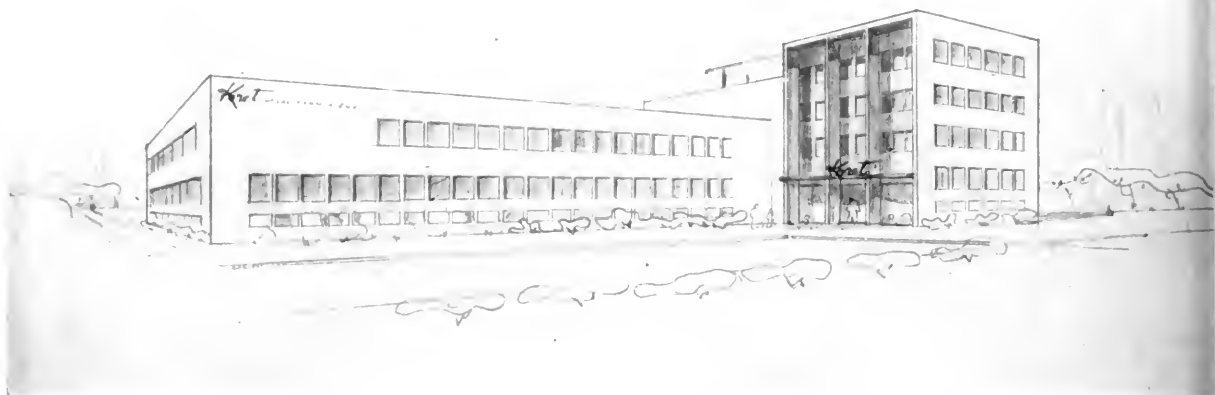

**ARCHITECT DESIGN OF TYPICAL BUILDING**

been pleasingly grouped about an open court in the center of which lies the swimming pool. This pool, and its adjacent areas, will be used for open-air fashion shows, while the primary function of the auditorium is for indoor shows and buyers' conventions.

When it was originally proposed to place the project on its present site, some objection was raised because of the distance buyers would have to travel from their hotels in the downtown area. It was easy to show that the time spent by the buyer traveling by taxi from downtown to the project was less than the time normally consumed in going between manufacturers in their present locations in the congested areas.

To facilitate customer convenience a garage occupies the basement of the buildings facing on Industrial Avenue and is entered from a service station area at the principal cross street of the project.

General administrative facilities and specially designed recreational sections, are located in the center of the City as is the Auditorium, with its recreational attractions, which connects with a library, a museum, and a tea room.

The Administrative building will be six stories in height and will contain offices, drug store, and shops on the first floor, with restaurant and club facilities on the second and third stories. The bal-

(See Page 34)

Millwork for **APPAREL CITY**

*Specialists in  
Store and Office Fixtures*

All kinds of Industrial and Specialty  
Work

**PORTMAN'S MILL &  
CABINET SHOP**

ATwater 2558

245 BAYSHORE BLVD. SAN FRANCISCO

**CENTRAL ELECTRIC  
COMPANY, Inc.**

EVERETT W. CARLSON, Pres.

*Electrical Contractors*

for  
*Apparel City*

EX 2180

610 Third Street San Francisco



**Arizona Chapter:**

James Macmillan, President; Arthur T. Brown, Secretary, 740 N. Country Club Road, Tucson, Arizona.

**Central Valley of California:**

Herbert E. Goodpastor, President; Frank V. Mayo, Secretary, 307 Exchange Building, Stockton 2, California.

**Colorado Chapter:**

Raymond H. Ervin, President; James M. Hunter, Secretary, 2049 Broadway, Boulder, Colorado.

**Montana Chapter:**

Ralph H. Cushing, President; H. C. Cheever, Secretary, Montana State College, Bozeman, Montana.

**Northern California Chapter:**

Hervey P. Clark, President; Lester Hurd, Vice-President; Ralph Pollack, Secretary; William C. Ambrose, Treasurer; 605 Market Street, San Francisco.

**Oregon Chapter:**

Francis Jacobberger, President; J. D. Annand, Secretary, 401 Central Building, Portland 5, Oregon.

**San Diego Chapter (California):**

H. Louis Bodmer, President; Louis J. Gill, Secretary, 203 Granger Building, San Diego, California.

**Santa Barbara Chapter (California):**

Roy C. Wilson, President; Miss Lulah M. Riggs, Secretary, 240 Middle Road, Santa Barbara, California.

**CALIFORNIA COUNCIL OF ARCHITECTS**

Vincent Palmer, President; Andrew Hass, Vice-President; A. C. Martin, Jr., Secretary-Treasurer; 369 Pine St., San Francisco 4.

**Southern California Chapter:**

Adrian Wilson, President; A. C. Martin, Jr., Vice President; Walter L. Reichardt, Secretary; George E. Gable, Treasurer; Chapter Headquarters, 3757 Wilshire Blvd., Los Angeles 5, California.

**Spokane Chapter (Washington):**

Noel E. Thomson, President; Kenneth D. Storment, Secretary, Hutton Building, Spokane, Washington.

**Utah Chapter:**

George Cannon Young, President; Theodore R. Pope, Secretary, 29 South State Street, Salt Lake City 1, Utah.

**Washington State Chapter:**

George W. Stoddard, President; Stephen H. Richardson, Secretary, 516 Central Bank Building, Seattle 4, Washington.

**Hawaii Chapter:**

Kenneth W. Roehrig, President; James Morrison, Secretary, 334 Federal Bldg., Honolulu, T. H.

---

**CALIFORNIA COUNCIL OF ARCHITECTS**

John S. Bolles, Chairman of the Committee on Governmental Relations, reported Assembly Bill 2117 of the California Legislature passed the Assembly Committee on Governmental Efficiency and Economy on May 7, 1947 with a "Do Pass" recommendation.

The Bill will now go to the floor of the Assembly and then to the Senate.

---

**NORTHERN CALIFORNIA CHAPTER A.I.A.**

The Chapter met on May 19, jointly with the Producers' Council and the Building Industry Conference Board, to hear Mr. Tyler Rogers, National President of the Producers' Council and a vice president of the Owens Corning Fiberglass Corporation speak on "Building Costs Can Be Reduced."

Rogers spoke on ways and means of improving the materials supply situation and the difficult labor supply conditions. He stressed the "absolute importance to the entire industry that building costs be reduced through greater labor productivity, fair prices and the adoption of advanced techniques that will eliminate waste and unnecessary costs in the building of homes and other structures."

---

**SAN FRANCISCO ARCHITECTURAL CLUB**

An interesting and educational discussion of "Plastics" was presented members of the Club on June 4th, when Ferdinand T. Kebely, widely known industrial designer and plastics engineer addressed the group.

Many samples of the use of plastics were exhibited by the speaker.

---

**SCIENTIFIC RESEARCH**  
**UNIVERSITY OF CALIFORNIA**

Dean L. M. K. Boelter, University of California College of Engineering at Los Angeles, has announced the addition of a new type electron microscope which is about 100 times as powerful as an ordinary microscope and will measure a 2,500,000th of an inch.

Also added to the school is a new spectrophotometer which measures the fraction of energy of light at any wave length by drawing a line on a piece of graph paper, and a powerful automatic X-ray machine that can be used for detecting structural defects in metals.

---

**PRODUCERS COUNCIL**

A special meeting of the Producers' Council, Northern California Chapter, was held in San Francisco on May 19, with the Building Industry Conference Board, the Associated General Contractors, the A.I.A., and other building groups to hear Mr. Tyler S. Rogers, National President of the Producers' Council and vice president of the Libbey-Owens-Ford-Glass Company.

Rogers spoke on the subject "The Problems of the Construction Industry Nationally," pointing out the great need for unity, exploitation, and public education within, as well as outside the construction industry.

The meeting was exceptionally well attended.

# WITH THE ENGINEERS

Structural Engineers Association of Northern California

William W. Moore, President; John A. Blume, Vice President; Franklin P. Ulrich, Sec.-Treas.; Offices 214 Old Mint Bldg., San Francisco, Phone GArtfield 3890. DIRECTORS, Mark Falk, M. V. Pregnoff, and R. D. Dewell.

American Society of Civil Engineers  
San Francisco Section

Theodore P. Dresser, Jr., President; Leon H. Nishkian and Sidney T. Harding, Vice Presidents; John E. Rinne, Secretary-Treasurer; 225 Bush St., San Francisco 20.

Puget Sound Engineering Council  
(Washington)

R. E. Kister, A. I. E. E., Chairman; E. R. McMillan, A. S. C. E., Vice Chairman; L. B. Cooper, A. S. M. E., Secretary; A. E. Nicherson, I. E. S., Treasurer; Offices, L. B. Cooper, c/o University of Washington, Seattle 5, Washington.

## STRUCTURAL ENGINEERS ASSOCIATION OF NORTHERN CALIFORNIA

A large delegation of members attended a joint meeting with the newly organized Structural Engineers Association of Central California in Sacramento on May 20th, and heard Mr. Gilbert E. Morris, Superintendent of Building and Safety, City

of Los Angeles speak on the subject "Overlapping Building Codes and the Need for Unification."

Morris' remarks were directed at several measures pending in the present California Legislature, as well as informative on the Los Angeles situation.

The Engineers took advantage of the meeting in Sacramento to indicate to members of the Senate and Assembly their favorable interest in Assembly Bill 2117 which permits state agencies to commission Engineers and Architects in private practice to perform services for the State.

\* \* \*

Annual Convention, tentative dates have been set for October 17, 18, 19 in Yosemite National Park, California.

## L. H. NISHKIAN, A.S.C.E.

Consulting Engineer

1882

1947

## NEW AGRICULTURE BUILDINGS

Two new buildings for the College of Agriculture of the University of California at Davis, California will soon be constructed, according to a recent announcement of the university's architectural and engineering department.

The campus will have a new science building, to cost in the neighborhood of \$670,000, and a soils and irrigation building, expected to total \$400,000.

A Forestry building at Berkeley for the newly established School of Forestry, will complete the construction program.

Eldridge Spencer, San Francisco, has been selected as the architect for the science building, and Arthur Brown, Jr., of San Francisco as the supervising architect of the Forestry building. Miller & Warnecke of Oakland have also been commissioned as architects on the Forestry building, while R. J. Evans will be supervising architect at the Davis construction.

## SCHOOL BONDS VOTED

Petaluma, California, voters have approved a \$550,000 bond issue for the construction of a new high school gymnasium, swimming pool, manual training and auto repair building. Rober Stanton, Pebble Beach is the architect.

## GREASE MANUFACTURING PLANT

The Standard Oil Company is taking bids on a \$5,000,000 grease manufacturing plant and packaging warehouse to be built at Richmond, California. W. D. Peugh, San Francisco, is the architect; L. H. Nishkian is the structural engineer.

*Real Estate Loans*



F. H. A. loans are readily available to aid in the purchase of existing homes or in the construction of new ones. You can buy or build a home and pay for it in small monthly installments like rent. For example, a 20-year loan of \$6000 would cost about \$49.56 per month, including real estate taxes, insurance, principal and interest.

**CROCKER FIRST NATIONAL BANK**

SAN FRANCISCO • OAKLAND  
*California's Oldest National Bank*

Member Federal Deposit Insurance Corporation

**EL RANCHO HOTEL**

The Thos Hull enterprises have been granted a CPA permit for the construction of the El Rancho Hotel in Reno, Nevada, at an estimated cost of \$504,880.

**DETROIT STEEL DIRECTORS**

William Gillett has been elected vice president, and H. D. Palmer, vice president and director of labor relations of the Detroit Steel Products Company at a recent company meeting.

Gillett, who joined the company in 1930, was made manager of the steel deck division in 1935, and head of the newly created building panels division in 1945. He is chairman of the Metal Roof Deck Technical Institute.

Palmer, joined the company in 1922 and has served as credit manager, assistant treasurer, and director of labor relations.

**ARCHITECT MOVES**

Harold G. Stoner, A.I.A., Architect has announced the removal of offices to No. 2 Santa Margarita Drive, San Rafael, California.

**RESEARCH CLEARING HOUSE**

A clearing house of technical research information in the field of building construction has been set up by the National Research Council of the United States Chamber of Commerce and will be known as the "Building Construction Research Board," according to a recent announcement of John C. Stevens, chairman of the chamber's Construction Industry Advisory Council.

The new board will be patterned after the existing Highway Research Board, and its principal function will be to collect and disseminate technical research information of importance to the building industry. It will also provide a meeting place for those actively engaged in research activities, where they will be able to exchange ideas.

**SWIMMING POOLS**

CPA permits have been granted for the construction of swimming pools in Columbia (\$22,000) and Brentwood (\$30,000), California schools.

**NEW POLICE STATIONS**

A CPA permit has been granted for the construction of a new police station and jail building in Dinuba, California, estimated to cost \$25,000. David H. Horn & Marshall D. Mortland of Fresno are the architects.

In Reno, Nevada, architects Blanchard, Maher & Lockard, are taking bids on a new police station and jail which will cost \$475,000. It is a 2-story and basement, reinforced concrete and steel building.

**How to keep your buildings young**



**Plan for built-in telephone outlets now**

Even though only one telephone is needed initially, plan others for your client's future convenience.



Specify that telephone conduit be installed during construction. It adds little to building costs . . . adds real value to the house.

Additional telephones may be added without drilling through the flooring or running wires along the baseboards.

And the convenience of well-placed telephone outlets will be appreciated year after year.



Call or dial your local Telephone Business Office. Ask for Architects and Builders Service.

**The Pacific Telephone and Telegraph Co.**



**A Beehive of Action**

Electrical Installation  
**APPAREL CITY**  
 San Francisco  
 by

**Associated Electrical  
 & Mechanical Co.**

223 Clara Street San Francisco



**MACNSONS**

Plumbing, Heating, and Air Conditioning

APPAREL CITY

151 Tehama St.  
 San Francisco

2301 Palm Ave.  
 San Mateo

ance of the building will be given over to general administrative offices of the corporation and to rental space for manufacturer's agents to display and sell products to the apparel industry.

The general design of individual buildings embodies a loft-type structure which is sufficiently flexible in their exterior arrangement to permit an individual type of entrance without destroying the architectural homogeneity of the overall project.

Not only has Apparel City succeeded in unifying an industry composed of individuals and groups who are professionally and artistically zealous of their abilities and jealous of their products but



Building 1A, 1B & 2, Apparel City

Ward & Bolles, Architects

**HAAS & ROTHSCHILD**  
**GENERAL CONTRACTORS**

*"Building with the West"*



when completed will provide better housing and better facilities at rental rates which cannot be obtained elsewhere on a comparable basis. The heating, lighting, and general design is built for the industry. Complete sprinkling systems as well as a filtering system for the air will be installed.

Once completed, Apparel City will place San Francisco out in front of the entire industry for modern, complete facilities for the manufacture, display, and sales of men's, women's and children's apparel. Domestic and Eastern buyers will be able to accomplish in one day what now takes from two to seven and they will be able to do this with greater ease, comfort and satisfaction.

Apparel City is no longer the dream of a few individuals.

### LIGHTING EXPOSITION AT CHICAGO

The Second International Lighting Exposition, to be held at the Stevens Hotel, Chicago, November 3-7, will feature a \$1,200 merit award contest on "What Planned Lighting Can Do." The purpose of the contest is to bring to the exposition outstanding examples of lighting application in industrial buildings, stores and offices.

### NEW JUNIOR COLLEGE

Monterey, California, have voted \$985,000 in bonds for a classroom wing auditorium, music building, and gymnasium to be added to the Junior College and High School. The construction is to be of reinforced concrete and frame. Robert Stanton is the architect.

### SEWAGE PLANT CONTRACT

DeLuca & Son of San Francisco, have been awarded a contract for the construction of a sewage treatment plant for the City of Fresno, California. Of reinforced concrete construction it is estimated to cost \$652,692.

### 40 WOODEN BUILDINGS

Approximately 40 wooden buildings, to serve as temporary classrooms, offices, and laboratories are being erected on the Los Angeles campus of the University of California. The buildings are 1-story U. S. Army surplus.

### APPLIANCES

The original cost of heating appliances should not deter architects from recommending their installation if they result in fuel savings, British Fuel Minister Shinwell told British architects recently. "It is well known that many improved appliances whose initial cost was high paid for themselves many times over by the resulting economy in fuel," he said.

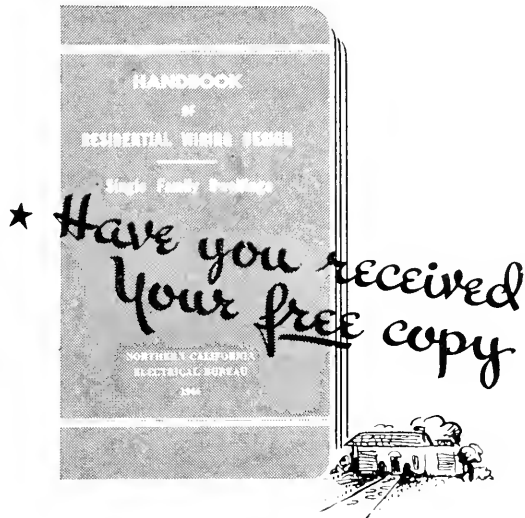

This handbook of residential wiring design for single family dwellings has been prepared especially for the use of architects, engineers, builders, electrical contractors and lending institutions.

It is not a handbook on how to *install* wiring . . . it is one on how to *plan* wiring. It sets forth . . . room by room . . . outlet and circuit requirements for an efficient, convenient and useful home wiring system . . . a system which will help avoid electrical obsolescence.

If you have not received your copy of this free handbook . . . or if you wish additional copies . . . contact your local utility office or this Bureau.



## NORTHERN CALIFORNIA ELECTRICAL BUREAU

1355 MARKET STREET  
SAN FRANCISCO 3

**BAXCO**  
CHROMATED ZINC CHLORIDE

**CZC**

**PRESSURE TREATED LUMBER**

● **PROTECTS AGAINST DECAY  
AND TERMITE ATTACK**

*Specify it in your home  
Available through Lumber Dealers*

LOS ANGELES 601 W. 5th Street Phone Michigan 6294	SAN FRANCISCO 333 Montgomery Street Phone DOuglas 3883
---	--

***J. H. Baxter & Co.***

**AGENTS FOR WEST COAST WOOD PRESERVING CO. SEATTLE, WASH.**

"GOODS OF THE WOODS"  
**E.K. WOOD LUMBER CO.**



**LOS ANGELES**

*Branch Offices*

HOLLYWOOD	SIERRA MADRE	UPLAND
PASADENA	TEMPLE CITY	LA VERNE
LONG BEACH	WHITTIER	SAN PEDRO
RIVERSIDE	ONTARIO	INDIO

**OAKLAND  
SAN FRANCISCO**

**HEADLINE NEWS & VIEWS**

By E. H. W.

National Association of Home Builders plan speed-up of home building, also consider labor and high construction costs—Edward R. Carr, president.

\* \* \*

A campaign against encephalitis, or "sleeping sickness," has been started by the University of California—Hope progress is reported before football season.

\* \* \*

The Federal Housing Administration's manual for underwriting operations has been revised and distributed to all FHA offices—Raymond M. Foley, Commissioner. Copies from Super. of Documents, U. S. Printing Office, Washington, D. C. at \$2 each.

\* \* \*

Immediate removal of rent ceilings on new construction as a means of encouraging the construction of more rental housing has been advocated by Douglas Whitlock, Chairman, Building Products Institute.

\* \* \*

Western building volume remains about the same as a year ago, although dollar valuation is slightly less. Los Angeles continues to hold its position as the No. 1 city for building volume.

\* \* \*

The admonition that "Fools names, like their faces, are always seen in public places," may be a causality of modern times with perfection of porcelain enameled panels.

\* \* \*

"It's no wonder you and other veterans are thoroughly confused about this housing problem. The fact is that there are so many 'experts' talking and writing about it and so many government agencies issuing directives and releasing propaganda, that even we who are building the houses are confused most of the time ourselves."—Frank W. Cortright, Executive Vice-President, National Ass'n of Home Builders.

\* \* \*

HEADLINE: "Owner taking bids on painting merry-go-round"—it's about time Uncle Sam did something about changing the red color scheme.

\* \* \*

Representatives of national organizations interested in management of business offices met in New York recently, under auspices of the American Standards Association, to establish machinery for developing the first nation-wide voluntary standards for office equipment, supplies and procedures.

# IN THE NEWS

## CHURCH ADDITION

The First Methodist Church of Oakland, California, have engaged Wm. E. Schirmer, Architect, to design additions to the Church which will cost approximately \$265,000.

## PLASTIC AWARD

Nominations for the John Wesley Hyatt Award for outstanding work in plastics during 1946 closed recently. Entries could be submitted by molders, tool makers, laboratory technicians, or any other person engaged in the production or development of plastics.

The John Wesley Hyatt Award, consisting of a gold medal and one thousand dollars, has been presented annually since 1941 under the sponsorship of the Hercules Powder Company.

## FACTORY BUILDING

A CPA permit has been granted for the construction of a new factory building at Pittsburg, California for the Dow Chemical Company, at an estimated cost of \$220,000.

## POLICE STATION

Architects J. Francis Ward and John S. Boles, have been retained by the City of San Francisco to design improvements to the Mission District Police Station which are estimated to cost \$100,000.

## HEATING PLANT

The McKinley Park School, Reno, Nevada, will have a new heating plant at a cost of \$49,153. General Contractor is the Hillcrest Plumbing Company of Reno.

## SWIMMING POOL

O. A. Deichmann, San Francisco Architect, has designed a swimming pool and bathhouse for the city of Willows, California. The CPA permit has been granted and low bid on a general contract was \$38,622.

## LIVESTOCK EXHIBIT BUILDING

A CPA permit has been granted for the construction of a new livestock exhibit building at the "Cow Palace" in San Francisco. Estimated cost is \$208,320.

NATUR-LITE  
FLUORESCENT



Clues to  
Quality!

The two labels of certification — Fleur-O-Lier and Smoot-Holman — tell the whole story of quality. Behind these labels are certified ballast, certified starters, certified reflection factors... as well as sturdy, dependable construction. It pays to buy Smoot-Holman quality and performance, neither have been sacrificed for price appeal.



Offices in Principal Western Cities — Branch and Warehouse in San Francisco

# Plan for health-safety ... it comes first

Whether it's a hospital, church, school or public building, architects know that the specification of Halsey Taylor Drinking Fountains is an assurance that health-safety comes FIRST! For these modern fountains were developed primarily to protect the user from contamination. Sanitation is as important as design... Halsey Taylors provide both! Get our latest literature.

THE HALSEY W. TAYLOR CO.  
WARREN, OHIO  
West Coast Plant Redlands, Calif.



*Halsey-Taylor*  
**DRINKING FOUNTAINS**

A-3

**FOR BETTER SERVICE**  
*Remember that*  
**KRAFTILE is**  
**WESTERN HEADQUARTERS**  
**FOR**

- ▶ GLAZED Structural Wall Units
- ▶ PATIO Tile
- ▶ QUARRY Tile
- ▶ SWIMMING POOL Overflow Gutter
- ▶ ACID Brick
- ▶ ACID-PROOF Jointing Compounds
- ▶ ACID-PROOF Floor and Tank Construction
- ▶ ACID-PROOF Coatings



- ▶ QUONSET Packaged Steel Buildings
- ▶ STRAN-STEEL Framing

For complete information and prompt service, phone or write

**KRAFTILE COMPANY**

NILES, CALIFORNIA NILES 3611  
SAN FRANCISCO: 50 Hawthorne Street — DOUGLAS 3780  
LOS ANGELES: 316 E. Commercial Street — MUTUAL 2411

## CUTTING HIGHWAY COSTS

Unnecessary costs in highway construction resulting from such refinements as too-strict tolerances, hand-rubbed concrete surface finishes on farm-to-market roads, and overly-high percentages on compaction of fills, were cited as examples of what can be considered in the way of possible economics by the Associated General Contractors of America at their recent joint meeting with the American Association of State Highway Officials at Los Angeles.

The contractors pointed out that specifications writers would do well to outline such tolerances as could be obtained by machinery only without expensive hand labor. Ninety per cent compaction of fills instead of 95 per cent would also save the taxpayer considerable money, it was contended.

## TEMPORARY CLASSROOMS

A CPA permit has been granted for the construction of temporary classrooms at the Richmond (Calif.) Union High School District. Architects Dragon, Schmidts and Hardman of Berkeley, report the work will cost \$90,000.

## HOSPITAL CONSTRUCTION

A nationwide Federal-state hospital construction program, as provided by the Hospital Survey and Construction Act of August, 1946, will soon get under way with the issuance of regulations governing the program by Surgeon General Thomas Parran of the United States Public Health Service.

The act permits appropriations up to \$3,000,000 to assist states in surveying and planning their hospital needs, and \$75 million annually for the next five years for the construction of hospitals and health centers. Money for the actual construction, however, will have to be appropriated by Congress.

## GRAMMAR SCHOOL

Milbrae, California, have voted \$250,000 bonds for a new 6-classroom and kindergarten school. Masten & Hurd, San Francisco, are the architects.

## DRIVE IN MARKET

Daley Bros., Belmont, California, contractors have been selected to build a new \$200,000 concrete and frame drive-in-market at Salinas, California.

## 35 HOMES

Private plans have been prepared for the building of 35 residences in Pittsburg, Calif., to average \$6000. They will be built by the owner, Seeno & DiMaggio.

(From Page 20)



**EFFECTIVE NIGHT LIGHTING ON DISPLAYS**

In the case of the McAlister building this problem was solved by the use of radiant heating units installed in the concrete floor slab. Thus throughout the entire work area, some 8000 feet in extent, a hot water copper tube panel heating system was installed.

Many difficulties had to be overcome in the layout of the plan however as in the greater part of the work area were hoist installations with their extensive mechanical features which extended below the concrete floor level and thus had to be by-passed. This problem was successfully met by the plumbing contractors.

The resulting effects of the radiant heating installations has been of keen interest to many people and of even more importance is the fact that the mechanics who actually work under the new conditions are themselves thoroughly "sold" on the system.

#### **Sales Room Illumination**

The lighting in the showroom was designed to sell automobiles and is based upon creating the proper brightness on displays and their surroundings.

A general intensity of 35 foot candles is produced at car levels. Accent can be provided from incandescent floodlights. The general fluorescent is re-

## **McAlister Auto Dealers**

*Installation of*

**Terra Cotta Ceramic**

**Veneer**

*and*

**Concrete Block Walls**

**Wm. A. Rainey & Son**

323 Clementina

SUtter 0072

**Complete Electrical Work**

for

**McAlister Burlingame**

**Auto Sales**

INSTALLED BY

**Engineering Design Co.**

24 CALIFORNIA STREET  
SAN FRANCISCO, CALIF.

1044 BROADWAY  
BURLINGAME, CALIF.

## **PLUMBING and RADIANT PANEL HEATING**

*in the*

**McALISTER AUTO DEALERS**

*Installed by*

**HARRY LEE**

145 ROLLINS RD.

BURLINGAME, CALIF.

## **HEATING AND VENTILATING**

INSTALLED IN

**McALISTER AUTO DEALERS**

BY

**Atlas Heating and  
Ventilating Co., Ltd.**

554 - 4th Street, San Francisco

DO 0377

# STRUCTURAL STEEL

For Class A Buildings,  
Bridges, etc.

**JUDSON PACIFIC - MURPHY CORP.**

4300 EASTSHORE HIGHWAY  
EMERYVILLE, CALIF.

## FORDERER CORNICE WORKS

*Manufacturers of*

Hollow Metal Products • Interior Metal Trim  
Elevator Fronts and Cabs  
Metal Plaster Accessories • Sanitary Metal Base  
Flat and Roll Metal Screens  
Metal Cabinets • Commercial Refrigerators

**269 POTRERO AVE.**

**SAN FRANCISCO, CALIF.**

**HEMLOCK 4100**

## VALUABLE NEWS SERVICE

- **BUILDING MATERIAL DEALERS**
- **CONTRACTORS**
- **ENGINEERS**
- **FINANCIAL INSTITUTIONS**

**ARCHITECTS REPORTS** gives advance news on construction projects in Northern California, lists: name of projects, location, architect, proposed cost and other pertinent information.

**HANDY** individual slip-reports, issued daily at a total cost of only  
\$10 a month

## ARCHITECT'S REPORTS

Published Daily

The **ARCHITECT and ENGINEER, Inc.**

68 Post Street, San Francisco - DO 8311

cessed in continuous rows 20' long and 11' on centers.

Effectiveness of the results is obtained by the use of a new curved Holophane Controlens and the installation is the first in any automobile plant on the Pacific Coast. The lens, not only directs the light to the seeing level but encloses the lamps to prevent glare and dust depreciation.

While the general intensity is quite uniform there is sufficient direct character to the light to produce jewel effect which is so desirable in display.

The service shop was provided with 25 foot-candles of general lighting with higher values where the lights were localized near work benches. Prismatic reflectors are of the high efficiency direct type which also provide a small percentage of upward light to reduce surrounding contrast.

In the Paint Spray Room a level of 40 foot-candles is provided and this average holds fairly well for both vertical and horizontal surfaces. The lights are located at the intersection of walls and ceiling and are at a angle of 30 degrees. Because of the hazardous nature of spray rooms, the lamps are accessible only from outside the room thru removable covers. No access to the lamp or interior of the fixtures is possible from within the spray room.

Intensities of 30 to 50 F-C in spray rooms are compromise levels between the high intensity required to produce brightness in black finishes and the lesser intensities required for light colors. Thus the design represents greatly improved visibility, maximum safety and economical operation.

### APPOINT DEALER

The Aluminum Awning Distributors, San Francisco, have been appointed representatives of the Aluminum Awning Company, Division of the Orchard Bros., Inc. of Rutherford, N. J.

The line includes roll-up aluminum awnings for all types of commercial industrial and residential uses.

### SANITARIUM

A sanitarium building expected to cost \$400,000 will soon be started in Mt. Eden, California, by the owner, the Jackson Home for Convalescent. D. D. Stone and Lou Mulloy of San Francisco are the architects.

### ARCHITECTS MOVE

The architectural firm of Sutton, Whitney & Aandahl have moved into new offices at 512 Failing Building, Portland, Oregon. They were formerly located in the Lewis Building, Portland.

# ESTIMATOR'S GUIDE

## BUILDING AND CONSTRUCTION MATERIALS

PRICES GIVEN ARE FIGURING PRICES AND ARE MADE UP FROM AVERAGE QUOTATIONS FURNISHED BY MATERIAL HOUSES TO SAN FRANCISCO CONTRACTORS. 2½% SALES TAX ON ALL MATERIALS BUT NOT LABOR

All prices and wages quoted are for San Francisco and the Bay District. There may be slight fluctuation of prices in the interior and southern part of the state. Freight cartage, at least, must be added in figuring country work.

**BONDS—Performance—\$10 per \$1000 of contract. Labor and materials, \$10 per \$1000 of contract.**

**BRICKWORK—**

Common Brick—Per 1M laid—\$80.00 to \$100.00 (according to class of work).  
 Face Brick—Per 1M laid—\$150 to \$200 (according to class of work).  
 Brick Steps—\$2.30 per lin. ft.  
 Brick Veneer on Frame Bldg.—Approx. \$1.50 per sq. ft.  
 Common Brick—\$26.00 per M, truckload lots, f.o.b. job.  
 Face Brick—\$60 to \$100 per M, truckload lots, delivered.  
 Cartage—Approx. \$5.00 per M.

**BUILDING PAPER—**

1 ply per 1000 ft. roll..... \$5.30  
 2 ply per 1000 ft. roll..... 7.80  
 3 ply per 1000 ft. roll..... 9.70  
 Brownskin, Standard, 500 ft. roll..... 7.00

**BUILDING HARDWARE—**

Sash cord com. No. 7..... \$2.65 per 100 ft.  
 Sash cord com. No. 8..... 3.00 per 100 ft.  
 Sash cord spot No. 7..... 3.65 per 100 ft.  
 Sash cord spot No. 8..... 4.00 per 100 ft.  
 Sash weights, cast iron, \$75.00 ton.  
 Nails, \$3.42 base.

**CONCRETE AGGREGATES—**

The following prices net to Contractors unless otherwise shown. Carload lots only.

	Bunker per ton	Del'd per ton
Gravel, all sizes	\$2.44	\$2.75
Top Sand	2.38	3.13
Concrete Mix	2.38	3.06
Crushed Rock, ¼" to ¾"	2.38	2.94

	Bunker per ton	Del'd per ton
Crushed Rock, ¾" to 1½"	\$2.38	\$3.13
Roofing Gravel	2.81	3.50
River Sand	2.50	3.06

**Sand—**

Lapis (Nos. 2 & 4)	3.56	3.94
Olympia (Nos. 1 & 2)	3.56	3.88

**Cement—**  
 Common (all brands, paper sacks), carload lots, \$3.02 per bbl. f.o.b. car; delivered \$3.40.  
 Cash discount on carload lots, 10c a bbl., 10th prox., less than carload lots \$4.00 per bbl. f.o.b. warehouse or delivered.  
 Cash discount 2% on L.C.L.

Atlas White	1 to 100 sacks, \$3.13 sack warehouse or del.; \$9.56 bbl. carload lots.
Calaveras White	
Medusa White	

**DAMP-PROOFING and Waterproofing—**

Two-coat work, \$5.00 per square.  
 Membrane waterproofing—4 layers of saturated felt, \$9.00 per square.  
 Hot coating work, \$3.00 per square.  
 Medusa Waterproofing, \$3.50 per lb. San Francisco Warehouse.  
 Tricocel waterproofing.  
 (See representative.)

**ELECTRIC WIRING—\$15 to \$20 per outlet for conduit work (including switches).**

Knob and tube average \$6.00 per outlet. (Available only for priority work.)

**ELEVATORS—**

Prices vary according to capacity, speed and type. Consult elevator companies. Average cost of installing a slow speed automatic passenger elevator in small four story apartment building, including entrance doors, about \$8000.00.

**EXCAVATION—**

Sand, \$1.00; clay or shale, \$1.50 per yard. Trucks, \$30 to \$45 per day.  
 Above figures are an average without water. Steam shovel work in large quantities, less; hard material, such as rock, will run considerably more.

**FIRE ESCAPES—**

Ten-foot galvanized iron balcony, with stairs, \$250 installed on new buildings; \$300 on old buildings.

**FLOORS—**

Composition Floors, such as Magnesite, 50c per square foot.  
 Linoflor—2 gages—\$3.00 per sq. yd.  
 Mastipeve—\$1.50 per sq. yd.  
 Battleship Linoleum—available to Army and Navy only—⅛"—\$3.50 sq. yd.  
 ⅜"—\$3.50 sq. yd.  
 Terazzo Floors—\$1.50 per sq. ft.  
 Terazzo Steps—\$2.50 per lin. ft.  
 Mastic Wear Coat—according to type—20c to 35c.

**Hardwood Flooring—**

Standard Mill grades not available.  
 Victory Oak—T & G  
 ⅜" x 2¼"..... \$252.00 per M. plus Cartage  
 ½" x 2"..... \$210.00  
 ½" x 1½"..... 200.00  
 Prefinished Standard & Better Oak Flooring  
 ⅜" x 3¼"..... \$265.00 per M. plus Cartage  
 ½" x 2½"..... 237.00 per M. plus Cartage  
 Maple Flooring  
 ⅜" T & G Clear \$330.00 per M. plus Ctg.  
 2nd 305.00 per M. plus Ctg.  
 3rd 255.00 per M. plus Ctg.  
 Floor Layers' Wage, \$1.87½ per hr. (Legal as of Jan. 21, 1946. Given us by Inlaid Floor Co.)

**GLASS—**

Single Strength Window Glass..... \$ .40 per □ ft.  
 Double Strength Window Glass..... .60 per □ ft.  
 Plate Glass, under 75 sq. ft..... 1.25 per □ ft.  
 Polished Wire Plate Glass..... 2.10 per □ ft.  
 Rgh. Wire Glass..... .60 per □ ft.  
 Obscure Glass..... .40 per □ ft.  
 Glazing of above is additional.  
 Glass Blocks..... \$2.75 per □ ft. set in place

**HEATING—**

Average, \$2.50 to \$3.00 per sq. ft. of radiation, according to conditions.  
 Warm air (gravity) average \$64 per register.  
 Forced air average \$91 per register.

**INSULATION AND WALLBOARD—**

Insulation—Full thickness	\$65.00 per M sq. ft.
Insulation—Full thickness	\$95.50 per M sq. ft.
Insulation—Festim Limited	\$33.50 per M sq. ft.
4'x6' panel	\$9.00 per panel
1/2" thickness	\$49.50 per M sq. ft.
3/4" thickness	\$69.00 per M sq. ft.
1" thickness	\$69.00 per M sq. ft.

**IRON**—Cast of ornamental iron, cast iron, depends on designs.

**LUMBER—**

No. 1 Common	\$90.00 per M
No. 2 Common	\$88.00 per M
Select O. P. Common	\$94.00 per M

**Flooring—**

V.G.-D.F. B & Btr. 1 x 4 T & G Flooring	\$170.00
"C" and better—all	170.00
"D" and better—all	170.00
Rwd. Rustic—"A" grade, medium dry	150.00
8 to 24 ft.	
"B" grade, medium dry	150.00
Plywood	15c to 18c per ft.
Plycord	9/2c per ft.
Plywall	9c per ft.
Plyform	15c per ft.

**Shingles (Rwd. not available)—**

Red Cedar No. 1—\$13.00 per square; No. 2, \$10.50; No. 3, \$9.00.  
Average cost to lay shingles, \$6.00 per square.  
Cedar Shakes—Tapered: 1/2" to 3/4" x 25"—\$17.00 per square.  
Resawn: 3/4" to 1 1/4" x 25"—\$22.00 per square  
Average cost to lay shakes,—8.00 per square

**MILLWORK—Standard.**

D. F. \$150 per 1000. R. W. Rustic \$175 per 1000 (delivered).  
Double hung box window frames, average with trim, \$12.50 and up, each.  
Complete door unit, \$15 to \$25.  
Screen doors, \$6.00 to \$8.00 each.  
Patent screen windows, \$1.25 a sq. ft.  
Cases for kitchen pantries seven ft. high, per lineal ft., \$12.00 each.  
Dining room cases, \$15.00 per lineal foot.  
Rough and finish about \$1.00 per sq. ft.  
Labor—Rough carpentry, warehouse heavy framing (average), \$60.00 per M.  
For smaller work average, \$60.00 to \$75.00 per 1000.

**MARBLE—(See Dealers)**

**PAINTING—**

Two-coat work .....per yard 60c  
Three-coat work .....per yard 80c  
Cold water painting .....per yard 25c  
Whitewashing .....per yard 15c  
Turpentine..... \$1.85 per gal. in 5-gal. cont.  
Raw Linseed Oil.....\$3.33 per gal. in 5-gal. cont.

Boiled Linseed Oil \$3.23 per gal. in drums.  
Boiled Linseed Oil—\$3.33 per gal. in 5-gal. containers.  
Replacement Oil—\$2.75 per gal. in drums, \$2.75 per gal. in 5-gal. containers.  
Use Replacement Oil \$3.00 per gal. in 1 gal. cont.  
A deposit of \$7.50 required on all drums.

**PATENT CHIMNEYS—**

6-inch	\$2.00 lineal foot
8-inch	2.50 lineal foot
10-inch	3.50 lineal foot
12-inch	4.50 lineal foot

**PLASTER—**

Neat wall, per ton delivered in S. F. in paper bags, \$17.60.

**PLASTERING (Interior)—**

3 Coats, metal lath and plaster	Yard \$3.00
Keene cement on metal lath	3.50
Ceilings with 3/4 hot roll channels metal lath (lathed only)	3.00
Ceilings with 3/4 hot roll channels metal lath plastered	4.50
Single partition 3/4 channel lath 1 side (lath only)	3.00
Single partition 3/4 channel lath 2 inches thick plastered	8.00
4-inch double partition 3/4 channel lath 2 sides (lath only)	5.75
4-inch double partition 3/4 channel lath 2 sides plastered	8.75
Thermax single partition; 1" channels; 2 1/4" overall partition width. Plastered both sides	7.50
Thermax double partition; 1" channels; 4 3/4" overall partition width. Plastered both sides	11.00
3 Coats over 1" Thermax nailed to one side wood studs or joists	4.50
3 Coats over 1" Thermax suspended to one side wood studs with spring sound isolation clip	5.00
Note—Channel lath controlled by limitation orders.	

**PLASTERING (Exterior)—**

2 coats cement finish, brick or concrete wall	Yard \$2.50
3 coats cement finish, No. 18 gauge wire mesh	3.50
Lime—\$4.00 per bbl. at yard.	
Processed LLime—\$4.15 per bbl. at yard.	
Rock or Grip Lath—3/8"—30c per sq. yd.	
5/8"—29c per sq. yd.	
Composition Stucco—\$4.00 sq. yard (applied).	

**PLUMBING—**

From \$150.00 per fixture up, according to grade, quality and runs.

**ROOFING—**

"Standard" tar and gravel, 4 ply—\$11.00 per sq. for 30 sqs. or over.  
Less than 30 sqs. \$14.00 per sq.  
Tile \$40.00 to \$50.00 per square.  
Redwood Shingles, \$15.00 per square in place.  
5/2 #1-16" Cedar Shingles, 4 1/2" Exposure .....\$16.50 square

5/8 x 16"—#1 Cedar Shingles, 5" Exposure ..... \$17.00 square  
4/2 #1-24" Royal Shingles, 7 1/2" Exposure ..... \$18.25 square  
Re-coat with Gravel \$5.50 per sq.  
Asbestos Shingles \$30 to \$60 per sq. laid.  
1/2 x 25" Resawn Cedar Shakes, 10" Exposure ..... \$18.50  
3/4 x 25" Resawn Cedar Shakes, 10" Exposure ..... 21.00  
1 x 25" Resawn Cedar Shakes, 10" Exposure ..... 22.00  
Above prices are for shakes in place.

**SHEET METAL—**

Windows—Metal, \$2.50 a sq. ft.  
Fire doors (average), including hardware \$2.80 per sq. ft.

**SKYLIGHTS—(not glazed)**

Copper, \$1.25 sq. ft. (flat).  
Galvanized iron, 65c sq. ft. (flat).  
Vented hip skylights 90c sq. ft.

**STEEL—STRUCTURAL—**

Base, delivered, \$3.06 per 100, plus normal extras; or \$300.00 to \$400.00 ton in place. Light truss work higher.

**STEEL REINFORCING—**

\$200.00 ton, set.

**STORE FRONTS (None available).**

**TILE—**

Ceramic Tile Floors—\$1.50 per sq. ft.  
Cove Base—\$1.25 per lin. ft.  
Glazed Tile Wainscot—\$1.50 per sq. ft.  
Asphalt Tile Floor 1/8" x 3/8"—\$.40 per sq. ft.  
Light shades slightly higher.  
Cork Tile—\$1.00 per sq. ft.  
Mosaic Floors—See dealers.  
Lino-Tile—\$1.00 per sq. ft.

**Wall Tile—**

Glazed Terra Cotta Wall Units (single faced) laid in place—approximate prices:  
2 x 6 x 12 .....\$1.25 sq. ft.  
4 x 6 x 12 ..... 1.50 sq. ft.  
2 x 8 x 16 ..... 1.45 sq. ft.  
4 x 8 x 16 ..... 1.75 sq. ft.

**VENETIAN BLINDS—**

75c per square foot and up. Installation extra.

**WINDOWS—STEEL—**

50c per square foot, \$5 for ventilators.

**ARCHITECT AND ENGINEER**



## NEW PRODUCT MAKES FOR MORE FLOOR SPACE

Especially suited to multiple housing units and small homes, the new Fain FOLDinette, which disappears, takes the place of the usual breakfast nook set. It also finds many acceptances where limited floor space demands maximum utilization.

Closed the FOLDinette is a modern cabinet in appearance, open it is a complete dining set.

It can be recessed into a standard 4" wall, or may be used on porches, patios, barbecues, and as a table or workbench in den or recreation room, or library.

The 32"x48" table has a mar-proof, alcohol proof, heat proof plastic top with chrome trim, while the seats are designed and constructed to place their entire weight upon the floor. Serves comfortable for 5 people.



## BUILDING TRADES WAGE (JOB SITES) NORTHERN AND CENTRAL CALIFORNIA

ATTENTION: The following are the PREVAILING hourly rates of compensation as determined by the Wage Adjustment Board, or which have been determined by the United States Department of Labor—Revised to July 1, 1946. Wage scales shown are those being paid and in effect mostly by agreement between employees and their union.

CRAFT	San Francisco	Alameda and Contra Costa	Marin	Vallejo	San Mateo	San Jose	Stockton	Sacramento	Fresno
ASBESTOS WORKERS.....	1.75	1.75	1.75	1.75	1.75	1.75	1.75	1.75	1.75
BRICKLAYERS.....	2.05	2.05	2.05	2.05	2.05	2.05	1.75	2.05	2.00
BRICKLAYERS, HODCARRIERS.....	1.57½	1.57½	1.57½	1.57½	1.57½	1.57½	1.47½	1.15	1.25
CARPENTERS.....	1.75	1.75	1.75	1.75	1.75	1.62½	1.50	1.50	1.50
CEMENT FINISHERS.....	1.75	1.75	1.75	1.75	1.75	1.75	1.75	1.75	1.75
ELECTRICIANS.....	1.87½	1.87½	1.87½	1.70	1.87½	1.87½	1.75	1.82½	1.75
ENGINEERS: MATERIAL HOIST.....	1.60	1.60	1.60	1.60	1.60	1.60	1.60	1.60	1.60
PILE DRIVER.....	2.00	2.00	2.00	2.00	2.00	2.00	2.00	2.00	2.00
STRUCTURAL STEEL.....	2.00	2.00	2.00	2.00	2.00	2.00	2.00	2.00	2.00
GLASS WORKERS.....	1.58½	1.58½	1.58½	1.58½	1.58½	1.21	1.40	1.37½	1.37½
IRONWORKERS: ORNAMENTAL.....	1.85	1.85	1.85	1.85	1.85	1.85	1.85	1.85	1.85
REINF. RODMEN.....	1.75	1.75	1.75	1.75	1.75	1.75	1.75	1.75	1.75
STRUCTURAL.....	2.00	2.00	2.00	2.00	2.00	2.00	2.00	2.00	2.00
LABORERS: BUILDING & CONCRETE.....	1.25	1.25	1.15	1.15	1.15	1.15	1.25	1.25	1.15
LATHERS.....	1.90	1.90	1.60	1.87½	1.75	2.00	1.87½	1.60	1.87½
MARBLE SETTERS.....	1.75	1.75	1.75	1.75	1.75	1.75	1.75	1.75	1.75
MOSAIC & TERRAZZO.....	1.75	1.75	1.75	1.75	1.75	1.75	1.60	1.16	1.12½
*PAINTERS.....	1.75	1.75	1.75	1.64	1.75	1.75	1.60	1.60	1.50
PILEDRIVERS.....	1.86	1.86	1.86	1.86	1.86	1.86	1.86	1.86	1.86
PLASTERERS.....	2.00	2.00	1.75	2.00	2.05	2.00	2.00	1.87½	1.87½
PLASTERERS' HODCARRIERS.....	1.75	1.75	1.75	1.75	1.75	1.75	1.65	1.65	1.40
PLUMBERS.....	1.87½	1.87½	1.87½	1.87½	1.87½	1.87½	1.87½	1.87½	1.87½
ROOFERS.....	1.50	1.62½	1.50	1.62½	1.25	1.37½	1.50	1.50	1.50
SHEET METAL WORKERS.....	1.75	1.75	1.75	1.75	1.75	1.75	1.75	1.75	1.75
SPRINKLER FITTERS.....	1.58	1.58	1.58	1.58	1.58	1.58	1.58	1.58	1.58
STEAMFITTERS.....	1.87½	1.87½	1.87½	1.87½	1.87½	1.87½	1.87½	1.87½	1.87½
STONESETTERS (MASONS).....	2.05	2.05	2.05	2.05	2.05	2.05	1.75	2.05	2.00
TILESETTERS.....	1.80	1.75	1.75	1.75	1.75	1.75	1.37½	1.37½	1.37½

Prepared and compiled by

CENTRAL CALIFORNIA CHAPTER, ASSOCIATED GENERAL CONTRACTORS OF AMERICA

with the assistance and cooperation of secretaries of General Contractors Associations and Builders Exchanges of Northern California.

# CLASSIFIED ADVERTISING

RATE: 10c PER WORD . . . CASH WITH ORDER

MINIMUM \$2.50

**ARCHITECT'S REPORTS**—A valuable advance news service giving building and construction information daily on projects in Northern California. Name, location, architect, proposed cost, etc., on individual slips. Ideal for securing new business leads. Hundreds of items, total monthly cost only \$10. Don't delay, subscribe today. ARCHITECT & ENGINEER, Room 618, 68 Post Street, San Francisco, California. Phone DOUGLAS 8311.

**PHOTOGRAPHS:** Specializing in building and construction photographs for publication, or historic records. For Industrial-Aerial Publicity photography use the INDUSTRIAL PHOTO'S, Room 722, Hearst Bldg., San Francisco, Phone SUtter 6953.

**METAL WINDOWS** (Steel-Aluminum-Bronze). Large Stock, ALL TYPES. STEEL SASH SALES & SERVICE, Weehawken, N. J.

**ENGRAVING**—Good engravings are essential to a satisfactory job of printing reproduction. For the best, see Poor Richard Photo Engraving Co., 324 Commercial St., San Francisco.

# SISALKRAFT

REG. U. S. PAT. OFF.

*"More than a building paper"*

**THE SISALKRAFT CO.**

205 West Wacker Drive  
Chicago, Ill.

55 New Montgomery Street  
San Francisco, Calif.

## CLINTON CONSTRUCTION CO. OF CALIFORNIA

**General Contractors**

923 FOLSOM STREET • SAN FRANCISCO  
SUtter 3440

## HOGAN LUMBER CO.

Wholesale and Retail

### LUMBER

MILL WORK • SASH & DOORS

Office, Mill, Yard and Docks  
SECOND AND ALICE STREETS • OAKLAND, CALIF.  
Telephone GLencourt 6861

## SANTA MARIA INN

### SANTA MARIA, CALIFORNIA

FRANK J. McCOY, General Manager

FERNAND E. PIMENTEL, Manager

On the  
Coast  
Highway  
between  
San  
Francisco  
and  
Los  
Angeles



American  
or  
European  
Plan  
•  
Old  
English  
Tap  
Room



The new Fain FOLDinette is produced by the Sierra Wood Products, Inc., of Pasadena, California, and is available thru building supply dealers.



### BOOM

An estimate that 1,100,000 homes and residential units will be built in the U. S. During 1947 has been made by the Department of Commerce. The total cost will be \$6 billion, excluding land cost and builders' profits.

### NEW LOCATION

Franklin, Kump & Faulk and the Ernest J. Kump Company have moved to 9 Main Street, San Francisco.

## BOOK REVIEWS

### PAMPHLETS AND CATALOGUES

**UN HEADQUARTERS.** By Le Corbusier. Reinhold Publishing Corp'n., 330 W. 42nd Street, New York. Price \$3.50.

An on-the-spot account of the seven month search for a suitable site for the United Nations Headquarters as carried on by an international group of experts. It is thus something of a historic document as seen through the eyes of an acknowledged master of planning who was closely involved with the entire proceeding.

Le Corbusier offers a model of urbanistic logic which should interest architects and city planners, although they may not agree with him.

**THERMAL INSULATION OF BUILDINGS.** By Paul Dunram Close, B. S. Reinhold Publishing Corp'n., 330 W. 42nd Street, New York. Price \$1.75.

Technical advisor to the Simpson Logging Company, Seattle, Washington; formerly technical secretary of the Insulation Board Institute of Chicago, and the American Society of Heating and Ventilating Engineers, the Author offers a comprehensive presentation of the principles and practices of building insulation. The purpose of the book is to provide information and data on various economic and comfort advantages of thermal insulating materials, to consider various types of insulation used principally in dwellings, and to explain how they are applied.

**ELEVATOR DOOR DETAILS.** Montgomery Elevator Co., Moline, Ill. A.I.A. File 33-G.

A new factual bulletin containing specific data for architects and engineers in determining elevator entrances. Copies upon request of publisher.

### INDUSTRIAL DIRECTORY OF MEXICO

The first industrial directory of Mexico, sponsored by the Confederation of Industrial Chambers of Mexico, has come off the press.

Included in the 1024 pages is a list of all Mexican industrial companies, their addresses, names of executive personnel, list of raw materials used by each company, products manufactured and financial data.

A special Spanish-English dictionary will be included with each directory covering most of the words used.

Complete information may be obtained from Publications Rolland, S de R. L., Plaza de la Republica No. 6-407, Mexico, D. F.

## "AMERICAN - MARSH"

### CONDENSATION UNIT

Pumping  
Machinery  
for  
Every  
Purpose

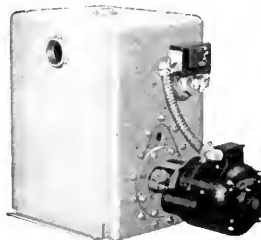

For Service  
Call  
DOuglas  
6794  
or  
MUtual8322

**SIMONDS MACHINERY CO.**  
SAN FRANCISCO      LOS ANGELES  
816 FOLSOM      455 EAST 4TH

## VERMONT MARBLE COMPANY

Producers and Finishers  
of  
Domestic and Imported Marbles

525 MARKET STREET, SAN FRANCISCO  
Phone SUtter 6747  
3522 COUNCIL STREET  
(Beverly Blvd. at Virgil Ave.)  
LOS ANGELES 4, CALIF.  
Telephone Fairfax 7834



**The Most Complete Line of  
STEELS and BUILDING MATERIALS**  
Made by a Single Producer



See Sweet's Catalog File or write us for  
full information.

**REPUBLIC STEEL CORPORATION**  
GENERAL OFFICES: CLEVELAND, OHIO

DENVER, COLORADO . . . . . CONTINENTAL OIL BUILDING  
LOS ANGELES, CALIFORNIA . . . . . EDISON BUILDING  
SALT LAKE CITY, UTAH . . . . . WALKER BANK BUILDING  
SAN FRANCISCO, CALIFORNIA . . . . . RIALTO BUILDING  
SEATTLE, WASH. . . . . WHITE-HENRY-STUART BUILDING

## PACIFIC MANUFACTURING CO.

HIGH CLASS INTERIOR FINISH  
QUALITY MILLWORK

142 SANSOME ST., SAN FRANCISCO  
GARfield 7755

6820 MCKINLEY AVE., LOS ANGELES  
THornwall 4196

BUILDERS EXCHANGE, OAKLAND

# RENEWING

## OUR PLEDGE

### OF

Sensible Prices for  
Quality Building  
Materials!

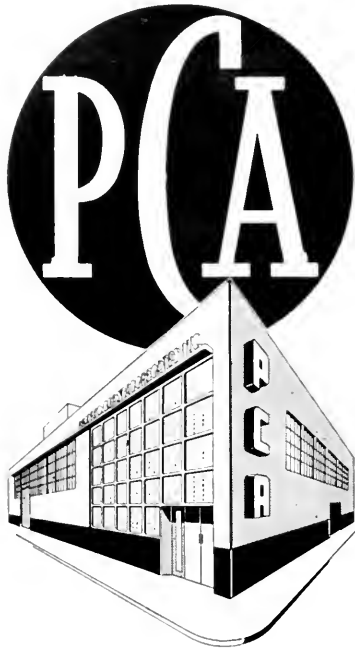

New San Francisco "Headquarters" Building of Pacific Coast Aggregates, Inc., at 400 Alabama Street . . . one of 48 PCA plants, offices and warehouses serving all Northern California.



Contact the nearest PCA office below

**SAN FRANCISCO**  
400 Alabama Street  
Klondike 2-1616

**OAKLAND**  
2400 Peralta Street  
Higate 0770

**FRESNO**  
414 P Street  
Ph. 4-3065

**SACRAMENTO**  
16th and A Streets  
Ph. 3-6506

**STOCKTON**  
1020 East Main Street  
Ph. 8-8643

**SAN JOSE**  
790 Stacktan Ave.  
BAIillard 8670

## IN THE NEWS

### GRAMMAR SCHOOL ADDITION

Four class rooms will be added to the Hamilton City, California, Grammar School at a cost of \$90,000. Bonds have been voted and a CPA permit granted, according to O. A. Deichmann, Architect of San Francisco.

### FACTORY BUILDING

A CPA permit has been granted for the construction of a new factory building by the Western Crown Cork & Seal Company in South San Francisco. Reinforced steel and concrete, the 600 x 600 foot building will cost \$850,000. Albert F. Roller, San Francisco is the Architect.

### 107 RESIDENCES

A general contract has been awarded David D. Bohannon organization for the construction of 107 residences in San Lorenzo Village, Alameda county. It is estimated the cost of each unit will approximate \$7,000.

### KEY SHORTAGES

The men who are putting up the houses these days are having their biggest job in finding five key materials: gypsum board and rock lath, millwork, hardware flooring, cast iron soil pipe and pressure pipe, and plumbing fixtures.

### PREFABRICATED SCHOOL

The Pasadena City School district has received bids for construction of a prefabricated school addition to the Willard Elementary School, Eash Pasadena. Transit exterior panels will be featured.

Plans prepared by Frederick Kennedy, Pasadena, architect.

### DRIVE-IN

A drive-in theater to cost \$120,000 will soon be built in Pittsburgh, Calif., by the Enea Brothers, owners. C. O. Peterson & W. R. Spackman, of San Francisco, are the architects.

### FLUORESCENT LAMP SAFETY GUARD

A new fluorescent lamp guard that supports the ends and prevents their falling out of lamp holders, is announced by the DEN-EL EQUIPMENT CO., Irvington 11, New Jersey.

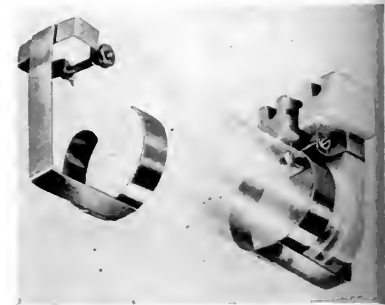

Easily installed permanently with a machine screw and nut, it is made of stainless steel and available in sizes for 40 watt and 100 watt lamps. Complete information upon request of manufacturer.

### SPEECH CORRECTION

Merritt E. Morris of Sparta, Georgia, submitted the winning design for the new Atlanta Junior League Day School of Speech Correction. An architectural student at Georgia Tech., Merritt's design was selected from more than 40 submitted.

# 3 IN 1 - KIMSUL

INSULATION  
COLD • HEAT • SOUND  
PERFECTLY CONTROLLED

TREATED AGAINST FIRE, MOISTURE, VERMIN AND INSECTS. ECONOMICAL,  
LIGHT, EASY TO HANDLE AND INSTALL.

## GUNN CARLE & CO

20 POTRERO AVENUE • SAN FRANCISCO, CALIF.

# THE TORMEY COMPANY

GENERAL PAINTERS  
AND DECORATORS

Phone UNderhill 1913

563 FULTON STREET  
San Francisco

# METAL WINDOWS

Steel—Aluminum—Bronze

Large Stock—ALL TYPES

Steel Sash Sales & Service

Weehawken, N. J.

# MULLEN MFG. COMPANY

BANK, STORE AND OFFICE  
FIXTURES—CABINET WORK  
OF GUARANTEED QUALITY  
CHURCH SEATING

Office and Factory:  
40-80 RAUSCH ST., Bet. 7th and 8th Sts.  
San Francisco  
Telephone UNderhill 5815

*Fine*  
**ENGRAVINGS**



**POOR  
RICHARD**

PHOTO ENGRAVING CO.  
220-324 COMMERCIAL STREET  
SAN FRANCISCO

# IN THE NEWS

## FACTORY BUILDING

Structural Engineer Leland S. Rosener of San Francisco, reports progress on the new \$2,000,000 Fibreboard Products Company plant at Antioch, California.

## HIGH SCHOOL ADDITION

The Arcata (California) High School District has received CPA approval of a \$156,000 classroom addition, according to Masten & Hurd, Architects of San Francisco.

## WOOD PULP MILL

A CPA permit has been granted for the construction of a \$2,836,000 wood pulp mill near Antioch, California. Leland S. Rosener of San Francisco is the Structural Engineer.

## NEW ROOF VENTILATOR

The Swartwout Company, Cleveland, have announced an addition to their line of industrial roof ventilating equipment called JECT-O-VALVE.

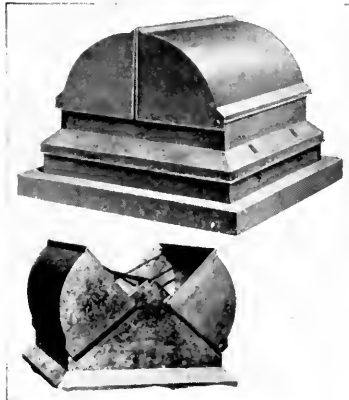

Made in five sizes, with a wide range of capacities, it uses a propeller type fan to exhaust heat, smoke, fumes, through a divided top which opens and closes automatically.

## SANTA CRUZ COURT HOUSE

A F. W. A. grant of \$42,000 has been made for the purpose of obtaining drawings for the construction of an "early California style" Court House building in Santa Cruz. Architect Charles E. Butner, estimates the building will cost in the neighborhood of \$800,000 when completed.

## SHOWROOM AND WAREHOUSE

Architects Binder & Curtis of San Jose, California, are preparing plans for a new office, showroom and warehouse building for Tay-Holbrook, Inc., San Jose. A CPA permit for \$50,000 has been granted.

## SWIMMING POOL

C. E. Kennedy, Stockton, has been awarded contract for construction of a swimming pool at the Oak Park Plunge, Stockton. Cost is estimated at \$79,513.

Phone GARfield 1164

# Thomas B. Hunter

Consulting Engineer

DESIGNER OF HEATING  
AIR CONDITIONING  
VENTILATING AND WIRING  
SYSTEMS, MECHANICAL  
AND ELECTRICAL EQUIP-  
MENT OF BUILDINGS

41 SUTTER STREET  
ROOM 710

San Francisco California

# Scott Company

HEATING . . PLUMBING . . TILE



243 MINNA STREET  
SAN FRANCISCO  
Phone EXbrook 6741



# HERRICK IRON WORKS

STRUCTURAL STEEL  
REINFORCING STEEL

18TH AND CAMPBELL STS.  
OAKLAND, CALIF.  
Phone GLencourt 1747

## INDEPENDENT IRON WORKS

Steel Buildings  
Service Stations  
Steel Storage Tanks  
Fabricated Plate Work  
Steel & Sheet Metal Products  
Fabricated Structural Steel  
Steel Distributors

Eighth & Pine Sts. Oakland, 7

## George F. Brayer

ELECTRICAL  
CONTRACTOR

166 Seventh Street  
San Francisco

Phone: MArket 1761

## PITTSBURGH TESTING LABORATORY

Successors to  
SMITH, EMERY & COMPANY

*Testing and Inspecting  
Engineers and Chemists*

Structural Materials, Structures  
Equipment, Pipe, Soils.

651 Howard St., San Francisco 5  
EXbrook 1747

## A. F. MATTOCK CO.

Builders

★

212 CLARA STREET  
SAN FRANCISCO

## Index to Advertisers

ALADDIN Heating Corp.	29 & 48
ALUMINUM Awning Co.	27
ATLAS Heating & Ventilating Co., Ltd.	39
ARCHITECTS Reports	40
ASSOCIATED Electrical & Mechanical Co.	34
BASALT Rock Company	Back Cover
BAXTER & Company, J. H.	36
BRAYER, Geo. F.	48
CAHILL Bros. Contractors	28
CENTRAL Electric Co., Inc.	30
CLASSIFIED Advertising	43
CLINTON Construction Company	44
CROCKER First National Bank	32
DETROIT Steel Products Co.	7
ENGINEERING Design Co.	39
FORDERER Cornice Works	40
FULLER, W. P. Co.	8
GUNN, Carle & Company	46
HAAS & Rotchild	34
HANKS, Inc., Abbot A.	48
HAWS Drinking Faucet Company	5
HERRICK Iron Works	47
HOGAN Lumber Company	44
HUNT, Robert W., Company	48
HUNTER, Thos. B.	47
INDEPENDENT Iron Works	43
JUDSON, Pacific-Murphy Corp.	29 & 40
KRAFTILE Company	38
LEE, Harry Plumbing	39
MACNSONS, Plumbing	34
MAKIN, Wm.	27
MATTOCK, A. F.	48
MICHEL & Pfeffer Iron Works	Inside Back Cover
MULLEN Mfg. Co.	47
MULLER Brass Co.	2
NORTHERN California Electrical Bureau	35
PACIFIC Coast Aggregates, Inc.	46
PACIFIC Coast Gas Association	1
PACIFIC Manufacturing Company	45
PACIFIC Portland Cement Company	*
PACIFIC Telephone & Telegraph Co.	33
PITTSBURGH Testing Laboratory	48
POOR RICHARD Engraving	47
PORTMAN'S Mill & Cabinet Shop	30
RAINEY, Wm. A. & Son	39
REED, Geo. W.	28
REMILLARD-Dandini Co.	48
REPUBLIC Steel Corporation	45
SANTA Maria Inn	44
SCOTT Co.	47
SIMONDS Machinery Company	45
SIMPSON Logging Co.	6
SISALKRAFT Company	44
SMOOT-Holman Co.	37
STANLEY Works, The	*
STEEL Sash Sales & Service	47
TAYLOR Co., Halsey W.	38
TORMEY Company, The	47
U. S. BONDS	*
VERMONT Marble Company	45
WESTERN Asbestos Company	Inside Front Cover
WOOD, E. K., Lumber Company	36

\* Indicates Alternate Months

## REMILLARD-DANDINI Co.

Brick and  
Masonry Products

★

400 MONTGOMERY STREET  
SAN FRANCISCO, CALIF.

## A L A D D I N Heating Corp.

Specializing in  
QUALITY HEATING  
EQUIPMENT

2222 San Pablo Avenue  
OAKLAND  
TWinoaks 1022

## ABBOT A. HANKS, INC. Engineers & Chemists

INSPECTING — TESTING — CONSULTING  
CONCRETE • STEEL • MATERIALS  
CHEMICAL AND TESTING  
LABORATORIES  
• RESEARCH AND INVESTIGATION •

TESTS OF STRUCTURAL MATERIALS  
DESIGN OF CONCRETE MIXES  
SHOP AND ERECTION INSPECTION OF  
STRUCTURES AND EQUIPMENT  
INVESTIGATION OF STRUCTURES  
AND MATERIALS  
TESTS AND INVESTIGATION OF  
FOUNDATION SOILS  
FIRE RESISTANCE AND INSULATION  
TESTS

624 Sacramento Street, San Francisco

## Robert W. Hunt Company ENGINEERS

Inspection • Tests • Consultation

Schools and Other Structures  
Are Built as Designed

*When Construction Materials are  
Inspected at point of Manufacture  
and during Erection by*

ROBERT W. HUNT COMPANY

Cement, Concrete, Chemical, Metallurgical,  
X-Ray and Physical Laboratories

Chicago • New York • Pittsburgh  
Los Angeles • All Large Cities  
San Francisco, 251 Kearny Street

# ARCHITECT AND ENGINEER



# DEPENDABLE



A  
"PACIFIC  
PRODUCT"

*Produced by*

**PACIFIC PORTLAND  
CEMENT COMPANY**

San Francisco • Los Angeles  
Portland

*Sold by*

**YOUR BUILDING  
MATERIALS DEALER**

# UNIFORM - TIME TESTED



# • ARCHITECT

Vol. 170 No. 1

# AND ENGINEER

ARCHITECTS' REPORTS—Published Daily  
Telephone DOuglas 8311

E. H. WILDER  
Editor

MARK DANIELS, A.I.A.  
Associate Editor

JOHN S. BOLLES, A.I.A.  
Book Reviews

MICHAEL GOODMAN  
Post-War Planning

E. N. KIERULFF\*  
Ass't Editor  
\*In the Service

★  
**Contents for**  
**JULY**

COVER PICTURE: The New Andrew Williams Store, Oakland, California (Page 22)

### ARTICLES AND MISCELLANEOUS TEXT

EDITORIAL NOTES . . . . .	4
NEWS & COMMENT ON ART . . . . .	9
PORCELAIN ENAMEL ON STEEL . . . . .	11
WORLD'S FIRST STEEL REINFORCED CONCRETE STRUCTURE . . . . .	12
By CURTIS TOBEY, Architect	
NEW JUDSON PACIFIC-MURPHY STEEL CORPORATION PLANT . . . . .	14
AT EMERYVILLE, CALIFORNIA	
TOMORROW'S HOUSE TODAY, San Francisco Home of Mr. and Mrs. Richard Walberg . . . . .	16
J. FRANCIS WARD & JOHN S. BOLLES, Architects	
ANDREW WILLIAMS STORE, Oakland, California . . . . .	22
DOUGLAS DACRE STONE & LOU B. MULLOY, Architects	
A.I.A. ACTIVITIES . . . . .	33
WITH THE ENGINEERS . . . . .	34
IN THE NEWS . . . . .	39, 41, 45, 47
ESTIMATORS GUIDE, Building and Construction Materials . . . . .	43
BUILDING TRADE WAGE SCALES, Northern and Central California . . . . .	45
CLASSIFIED ADVERTISING . . . . .	45
INDEX TO ADVERTISERS . . . . .	48

ARCHITECT AND ENGINEER (Established 1905) is published on the 15th of the month by The Architect and Engineer, Inc., 68 Post St., San Francisco 4; Telephone EXbrook 7182. President, K. P. Kierulff; Vice-President and Manager, L. B. Penhorwood; Treasurer, E. N. Kierulff.

Los Angeles Office: Wentworth F. Green, 6605 Hollywood Blvd., Los Angeles 28, Telephone HEMPstead 3171.

Entered as second class matter, November 2, 1905, at the Post Office in San Francisco, California, under the Act of March 3, 1879. Subscriptions United States and Pan America, \$3.00 a year; \$5.00 two years; foreign countries \$5.00 a year; single copy 50c. ARCHITECTS' REPORTS are published daily from this office Vernon S. Yallon, Manager



# • EDITORIAL NOTES •

## ENGINEERS NEEDED

A recent nation-wide survey, conducted among a representative group of companies operating in the electrical utilities field, showed that in the next fifteen years three times as many engineers will be needed within the industry as have been employed during the past fifteen years.

The reports were received from firms employing from 25 to 800 engineers.

Even with today's record enrollment in schools and colleges, the supply of engineers will not meet the demands, the survey showed.

\* \* \*

## APPRENTICESHIP AND EARLY PROFESSIONAL EXPERIENCE

"Graduation from an architectural school is no longer the true 'commencement'. For the increasingly scientific profession of architecture carries a heavy obligation to public safety and welfare, and legal restrictions have been thrown up which bar the graduate from practice until he has a wide range of practical experience and has proved the mastery of many technologies. There are, perhaps unfortunately, several sharply defined periods of training—College, apprenticeship, state board examination and professional life—but a strong effort is being exerted to coordinate them into one smoothly progressing accumulation of knowledge.

... "There is no beginning. There is no end. No architect worthy of the name will cease striving to master new methods, techniques, and materials that will add to the well-being of the people or the majesty of their estate.

"One thing in particular marks the end of college as an obstacle or interruption in training—the graduate must depend upon employment for its continuation. No practical means have yet been found to bridge the gap between college and architectural practice with opportunities for the normal expansion of skill such as that available to the medical interneer in the hospital. . . .

"Frequently, therefore, the architectural graduate finds the hurdle uncertain and filled with contradictions. He must test and improve the tools he has learned to use and give a full measure of service as an employee, yet remain dependent upon the professional spirit of his employer for an opportunity to learn all the other things necessary to pass his state board examination and enjoy a successful independent practice. . . .

"Once having obtained a good background of practical knowledge, the ambitious man will look

forward to an office of his own. The shift from employee to architect holds all the thrills of accomplishment but involves a less sharply defined change than that from student to employee. . . .

"Regardless of procedure, he will be upon the threshold of a professional career that offers astonishing opportunities and many new frontiers. The most adventurous ones may go forth as pioneers into communities where no architects are established. Those who take this courageous journey may find the path as hard and discouraging as that of the country doctor—but just as satisfying. The practice of architecture requires an abundance of imagination and devotion. Yet, to those who persist and are strong of heart, success will bring a glow of pride that comes only to those who have won important battles in the fight to build a great America." C. Julian Oberwarth, F.A.I.A. in "Architecture A Profession and A Career" published by The American Institute of Architects.

\* \* \*

## BUSINESS OPPORTUNITY

Never before in the history of this Nation has there been the varied opportunity for business development as that which now exists on the Pacific Coast.

Expanding spheres of thinking are opening industrial, commercial and professional activities into many parts of the world, heretofore considered beyond the reach of the average individual or firm.

But right here at home there is a development taking place that is realized by few—basic industrial expansion, enlargement of commercial facilities, development of natural resources, agricultural, professional and labor are all involved.

In California alone, more than \$8,818,590,000 was spent last year in the normal channels of trade, representing an increase of 35% over the previous year and establishing an all time high.

This does not include food for the family table and other expenditures not subject to the California sales tax, nor does it include the amounts represented in gasoline sales.

There is no question but what the "Opportunity is Here," the question is "Shall we take advantage of it?"

The recently enacted Federal labor laws may change the philosophy of "give and take"—you give and I take—to one of "take and give"—I'll take and you give.



*The*  
"BUBBLING BROOK"  
*was never like this*  
SANITARY · DEPENDABLE  
**HAWS**  
ELECTRIC  
WATER COOLER

To some, the symbol of perfectly clear, deliciously cold water may still be the old "bubbling brook". To others, those concerned with planning for the efficiency, modern appearance and comfort of businesses, both large and small, and for hospitals, public buildings and hotels, the HAWS Electric Water Cooler is the symbol of refreshment in the form of sanitary, cold water at instant command. The stainless steel top and streamlined metal cabinet create a cooler that is smart and distinctive. In your building or remodeling plans, specify and install HAWS, the finest in Electric Water Coolers... they're dependable and economical, too!

**WRITE TODAY** for full information on HAWS Electric Water Coolers and HAWS Sanitary Drinking Fountains

# **HAWS**

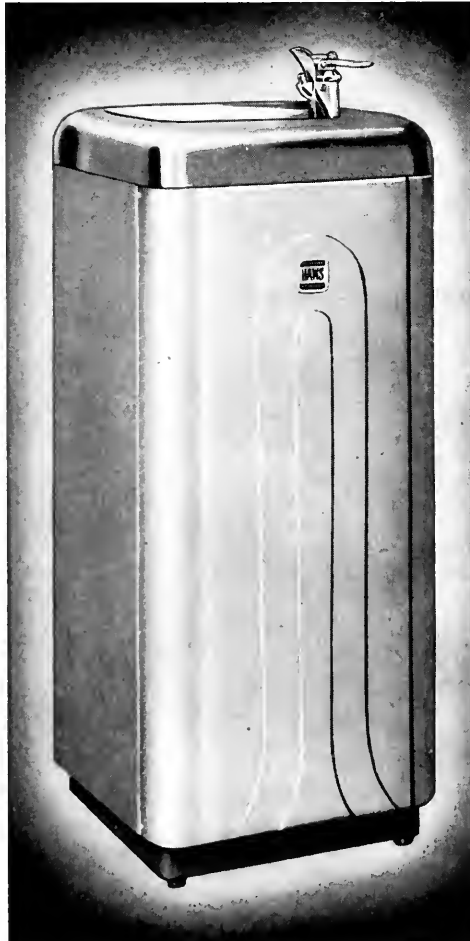

## **ELECTRIC WATER COOLERS**

### **HAWS DRINKING FAUCET CO.**

1808 HARMON STREET (SINCE 1909) BERKELEY 3, CALIFORNIA  
*Agents and Sales Representatives in All Principal Cities*

MADE FROM THE LONG FIBERS OF MATCHLESS DOUGLAS FIR

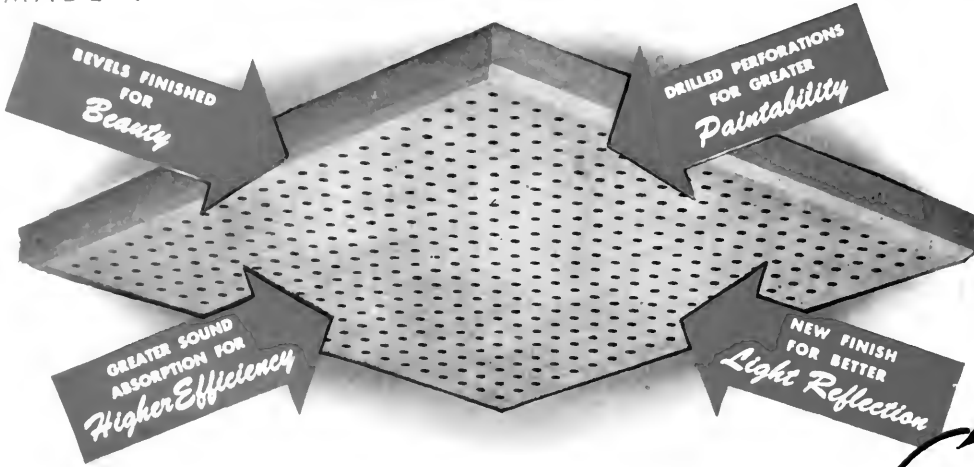

## NO OTHER PERFORATED ACOUSTICAL TILE GIVES ALL THESE ADVANTAGES for Noise-Quieting and Acoustical Correction

**A**S the result of more than half a century of experience in the wood products field, Simpson "know-how" has developed a new acoustical tile having the advantages long sought by architects and builders. Taking full advantage of the long and tough Douglas fir fiber, Simpson developed a new manufacturing process and new automatic controls guaranteeing uniformly high quality. Result is an improved post-war product . . . an acoustical tile of unparalleled quality . . . of higher sound absorption and designed to give greater ceiling beauty. By an improved process, the 484 perforations per tile unit are *drilled*. Because of the clean drilled perforations, the tile can be painted repeatedly without losing acoustical efficiency. Bevels are finished in the same attractive oyster-white as the tile surface, giving added beauty. Architects will find that noise-quieting and acoustical problems are solved easier with Simpson Acoustical Tile, and installations are much more attractive.

**Simpson**  
QUALITY SINCE 1895



# ACOUSTICAL TILE

WOODFIBER DIVISION • SIMPSON LOGGING COMPANY

Plant at Shelton, Washington • Sales Division, 1010 White Building, Seattle 1, Washington

Also manufacturers of LUMBER • PLYWOOD • DOORS

DISCUSS THIS NEW  
ACOUSTICAL TILE WITH  
YOUR NEAREST SIMPSON  
APPLICATOR

ALLIED CONSTRUCTION &  
SPECIALTY CO., INC.  
8455 Melrose Ave.  
Los Angeles 46, Calif.  
Phone: Walnut 0541

ANGELES INDUSTRIES  
984 McGarry St.  
Los Angeles, Calif.  
Phone: Vandike 1783

ARIZONA SASH, DOOR & GLASS CO.  
657 West St. Mary's Road  
Tucson, Ariz.  
Phone: 1699

CONSOLIDATED ROOFING & SUPPLY  
COMPANY  
520 South 7th Ave.  
Phoenix, Ariz.  
Phone: 47888

CONTINENTAL LUMBER CO.  
P. O. Box 2042  
Boise, Idaho  
Phone: 450

ELLIOTT BAY LUMBER CO.  
600 W. Spokane St.  
Seattle, Wash.  
Phone: Elliott 8080

ELLIOTT BAY LUMBER CO.  
2712 McDougall St.  
Everett, Wash.  
Phone: Main 150

EXCHANGE LUMBER & MFC. CO.  
P. O. Box 1514  
Spokane 7, Wash.  
Phone: Glenwood 1621

FROST HARDWOOD LUMBER CO.  
327-29 W. Market St.  
San Diego, Calif.  
Phone: F-7224

LUMBER DEALERS, INC.  
1301 Wozee St.  
Denver 17, Colo.  
Phone: Tabor 6141

LUMBER DEALERS, INC.  
108 South Main St.  
Pueblo, Colo.  
Phone: 4881

LUMBER DEALERS, INC.  
423 No. 33rd  
Billings, Mont.  
Phone: 3911

ROSE CITY FLOOR & INSULATING CO.  
Railway Exchange Building  
Portland, Ore.  
Phone: Atwater 6444

UTAH LUMBER CO.  
333 W. 1st So.  
Salt Lake City 9, Utah  
Phone: 4-4318

*Distinctive! . . . and standardized for economy*  
**THE FENCRAFT FAMILY\* OF WINDOWS**

**\*CASEMENT . . . PROJECTED . . . COMBINATION**

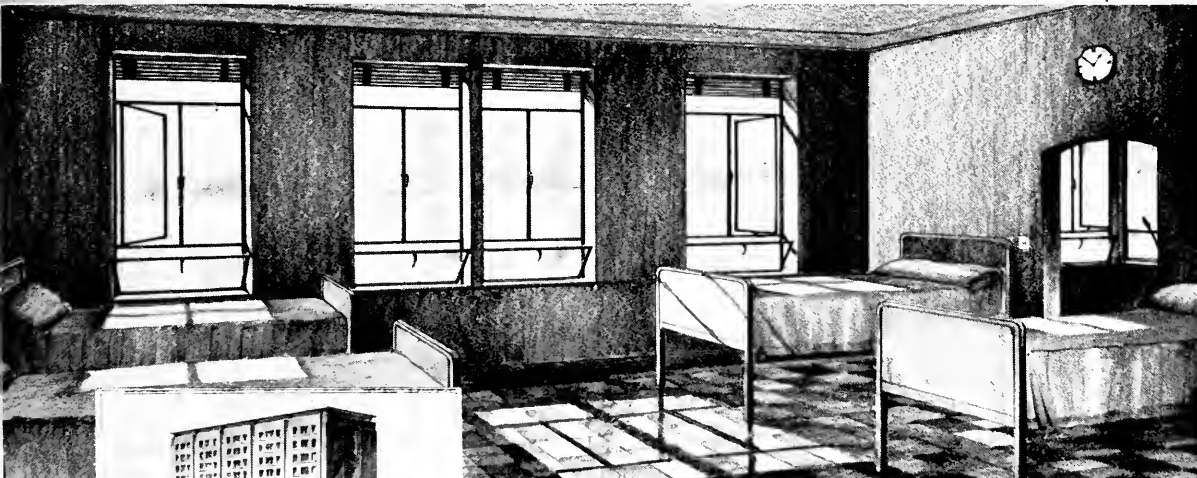

*Suggestion:* Provide more daylight and better fresh-air ventilation for a ward room in a general hospital with Fenecraft Standard Intermediate Combination Windows, such as Type 616 shown here. The sill vent provides excellent ventilation—deflects incoming air upward.

Distinctive window treatment is a mark of a truly fine building. Of course, you want it in the buildings you are planning—along with high quality and marked economy.

Then take a good, close look at Fenecraft. These windows were designed for beauty . . . for easy operation, year after year . . . for weather-tightness . . . for safe cleaning . . . for abundant fresh-air ventilation. *And then they were standardized for economy.*

This standardization economy takes two forms—both important. There's economy in first cost because standardization simplifies

and speeds production procedures. And there are real economies in installation because of uniform installation details and co-ordination of window dimensions with those of wall materials.

Fenecraft Windows are made of specially-designed casement sections—by craftsmen in the plants of America's oldest and largest steel window manufacturer. They're every bit up to the Fenestra standard. You can recommend them with confidence for the finest buildings. Fenecraft Windows are now being shipped to many localities. For product details, mail the coupon.

*Fenestra*



**FENCRAFT INTERMEDIATE STEEL WINDOWS**

Detroit Steel Products Company  
 Dept. AE-7  
 2262 East Grand Blvd.,  
 Detroit 11, Michigan

Please send me data on types and sizes of the new Fenecraft family of Fenestra Windows:

Name \_\_\_\_\_

Company \_\_\_\_\_

Address \_\_\_\_\_



**BIG ENOUGH to do it —**



**CAPABLE ENOUGH to do it right —**

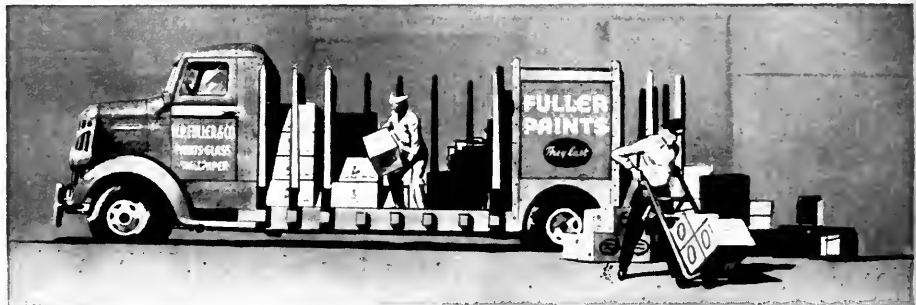

**NEAR ENOUGH to do it without delay —**

**F**uller stands *by* its customer by standing *back* of its products. That's policy! — made effective by laboratories and factories amply manned by experienced technicians. Our technical staff is large enough to keep abreast of architectural and maintenance needs with laboratory controlled qualities that have been proved on the job. Our 44 branches throughout the West assure you of ample stocks near at hand, no matter where your job may be. W. P. Fuller & Co.  
San Francisco 19, California.



# NEWS AND COMMENT ON ART

## SAN FRANCISCO MUSEUM OF ART

When Henry Moore's sculpture was first seen in New York last December, an entirely new phase in contemporary art seemed to open up. Despite the many isms and new developments the 20th century has wrought in art, sculpture has remained a stepchild to date, except for its possible new developments in the industrial world.

What probably explains the most universal and immediate success of Henry Moore, is the fact that he seeks reality in a universal sense, and that his abstractions are still all closely related to the phenomena of the human being, and its relations to nature herself.

Moore never speaks of a work of art, but merely of a work, and any work rightly conceived can be equally good.

Henry Moore was born July 30, 1898 in a small Yorkshire mining town where for several generations the men in his family had been either miners or farmers. From childhood on, however, Moore intended to become a sculptor. He was not able to realize this ambition until after the first World War when he won a traveling scholarship to the Continent. From that moment on, his art has developed in steady strides.

JULY CALENDAR OF EXHIBITIONS: HENRY MOORE: Sculpture and Shelter Drawings, through July; HELEN FRANCK of New York, Paintings, July 8 through August 3; EUROPEAN POSTERS, July 14 through August 3; TERESA ZARNOWA, paintings, July 8 through August 3; GRAPHIC CIRCLE, 25 Prints, July 8 through August 8.

AUGUST CALENDAR OF EXHIBITIONS: NATIONAL CERAMICS EXHIBITION from Syracuse, August 22 through September 14; HENRY MOORE: Sculpture and Drawing, through August; SELECTIONS FROM THE MUSEUM'S PERMANENT COLLECTIONS.

MUSEUM ACTIVITIES: BUDAPEST STRING QUARTET: presented by Mills College in association with the San Francisco Museum, Six Tuesday Evening Concerts, 8:30 p.m.

MUSICIANS: Josef Roisman, Edgar Ortenberg, Boris Kroyt and Mischa Schneider beginning July 8.

FILMS: KNOW YOUR WORLD, Saturdays and Sundays at 2:30 p.m.

## M. H. DE YOUNG MEMORIAL MUSEUM

Walter Heil, director, has announced the following program for the month of July:

EXHIBITIONS: Oils and Drawings by Max



SCULPTURES by HENRY MOORE

San Francisco Museum of Art

## NEWS AND COMMENT ON ART . . .

opening July 9; Fourth San Francisco International Exhibition of Photography by the California Camera Club; Watercolors by Charles Rogers through July 24; Prairie Print Makers, Sculpture by Henry Rox, Three-hundred Years of European Embroideries (from the Museum's collection), Watercolors of Flowers by Pancrace Bessa—c. 1772-1835, and Chinese Lowestoft Porcelain lent by the Metropolitan Museum of Art of New York will be shown through July.

**ART CLASSES:** The summer schedule conducted by Miriam Lindstrom will include: Children 5 to 10, Wednesdays 2:00 to 3:30 beginning July 16th and Fridays 2:00 to 3:30 beginning July 18th for Drawing and Painting for students 10 to 15 years old.

A special six-week course in observation and visual expression begins on Wednesday, July 16 at 10:00 a.m. and will be held Wednesday and Friday. Instruction free, materials provided.

### CALIFORNIA SCHOOL OF FINE ARTS

Douglas MacAgy, Director, announces that some classes are still available in the six-weeks summer session such as advanced painting, lithography, etching, and photography.

A night class in sculpture, jewelry design, and a course stressing the basic characteristics of form in painting and construction, vision and technique, will be conducted by Jean Varda, guest instructor.

Mark Rothko, also a guest instructor during the summer sessions, will conduct one advanced painting class and deliver a series of six lectures on contemporary art.

Minor White, will instruct in elementary technique as well as creative photography.

Mary Hiatt, will instruct the Pre-School Class, and Jean Kewell, will instruct the School Age Class, during the Summer Session.

---

### Permanent Collection

### M. H. DE YOUNG MEMORIAL MUSEUM



**PORTRAIT of VITTORIA COLONNA, Marchioness of Pescara, by Bronzino (Angelo Allori), 1502-1572.**



## CITY OF PARIS ART IN ACTION

Among gallery listings scheduled to be shown at the City of Paris during the latter part of July and the first part of August, is the Monotypes by Daniel Milhaud and John Mottram.

Arch Lauterer of the Drama Department at Mills College, Oakland, has been selected to confer with Architects in the design of the Civic Theatre to be built for the city of Pittsburgh, Pennsylvania.

### PORCELAIN ENAMEL ON STEEL

The fusing of a vitreous coating to a metal is not of recent origin. Centuries ago, it was a well-developed art in China and other parts of the Far East. Medieval craftsmen fashioned colorful vases, urns and objects of art by enameling gold, copper and brass.

Porcelain enamel on steel, however, is a new development. Research has brought continued improvement in raw materials and methods of manufacture. Today, the qualities of porcelain enamel on steel—durability, utility, ease of cleaning, unlimited range of colors, reflectivity, heat resistance and beauty are among its widely recognized features.

It has proved its worth as a building material. It is distinctly different from any other finish used for steel. It imposes no limitation on the imagination of the architect or designer for color, pattern or surface texture.

The colorful beauty of porcelain enamel will endure because of the inorganic composition of its vitreous coating. The lasting qualities of the coating distinguish porcelain enamel from other finishes.

The porcelain enamel industry has continuously developed new and better materials and methods. The result has been a steady advancement in the technique of applying porcelain enamel to steel.

This fadeless coating is a mixture of silica, borax, soda, zinc oxide and other inorganic materials. These are melted together at a high temperature—often as great as 2500 degrees F. Sudden immersion in water shatters the molten mixture into light, airy granules called "frit."

"Frit" is then ground with water, clay and other chemicals to form "slip." When the mixture is thin enough to pass a 200-mesh screen, it is applied to the steel sheet or shape by dripping or spraying. The "slip" is then dried, leaving a thin layer of very fine residual powder, or "bisque," on the steel.

The product to be enameled is then fired. Temperatures in the enameling furnace of about 1600

degrees F. fuse the "bisque" into a impervious smooth coating, tightly bonded to the steel. This first, or ground coat, is adequate for some applications. For others, one or two additional coats are applied and fired in a similar fashion.

Colors are produced by adding various inorganic materials to the finish or cover coats. Color panels can be selected with the assurance that they will retain their beauty and finish without fading, crazing or peeling.

Porcelain enamel on steel offers the architect an almost unlimited range of permanent colors in panels which can be fabricated to almost any contour, with great ease of maintenance. Washing with soap and water is all that is needed to restore the finish to its original condition.

The basic unit of architectural porcelain enamel is the panel. In general, there are three types of panels—sheets, pans and load bearing units.

Pans, usually with formed edges, either with or without backing or insulation, are the most common and enable the designer to conceal all fastenings. Load bearing units are porcelain-enameled pans with concrete backing. In most cases they are handled as a veneer. However, in some instances these units are heavier and are used in the same manner as any other form of masonry.

The sheets are very ductile, enabling the fabricator to produce deeply drawn and severely formed shapes. They are available in all standard gages and sizes and any shape which can be formed in steel can be given a permanent porcelain enamel finish.

Size of individual panels is determined by the gage of the base metal, the nature of the attachment, and whether or not supplementary backing material is employed. The backing material serves both as reinforcement and as insulating and sound-proofing.

Almost all types of insulating material have been found usable for backing and are applied with special adhesives. They are in turn backed by light-gage steel sheets.

Panels with a 20-gage base have been made as large as 15 square feet with proper reinforcement.

There are many methods of attaching porcelain enamel panels to furring strips, masonry, sheathing or structural members. Some are patented and most are adaptable to both interior and exterior use.

For all exterior panels and some interior applications the joints between the various sections should be caulked with special mastic compounds.

Porcelain enamel is difficult to modify after it is delivered to the site. If the architect attempts to detail the exact dimensions of each panel and its method of fabrication, he may be unwittingly

(See Page 46)

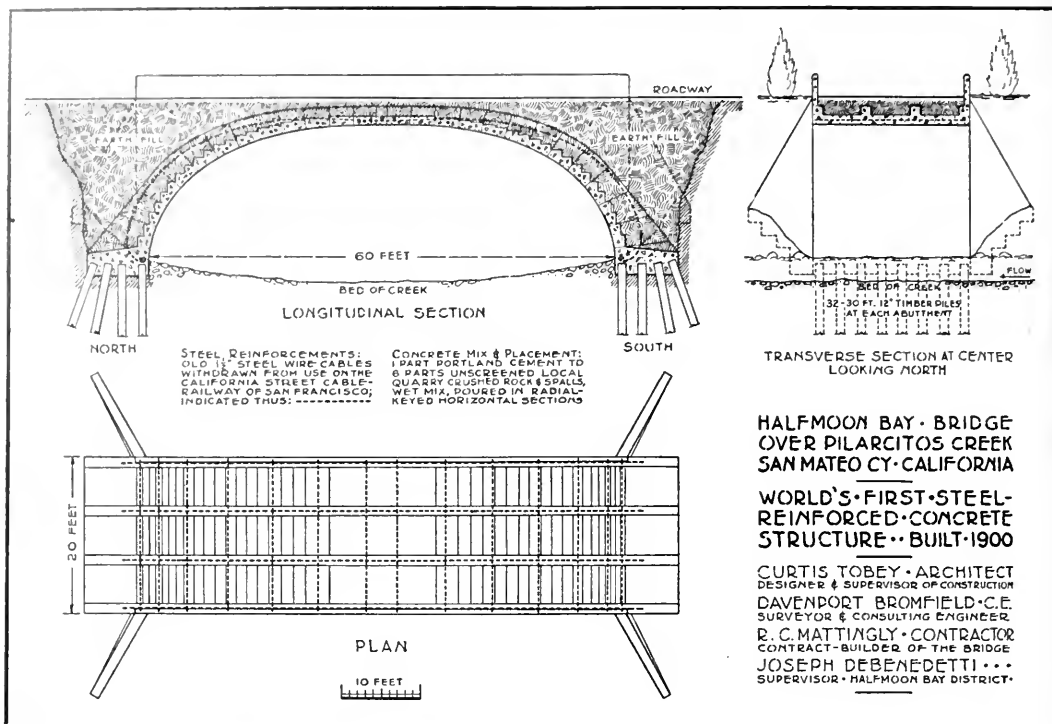

# World's First Steel Reinforced Concrete Structure

By **CURTIS TOBEY, Architect**

On Coastal State Highway No. 1, in the County of San Mateo, California, thirty miles south from San Francisco, the southbound motorist enters the town of Half Moon Bay—old Spanishtown—over a two-lane, steel-reinforced concrete bridge, long a prominent landmark in the seacoast community. From the highway approaches little can be seen of this bridge but its buttress rails and wing retaining walls; but, viewed from below in the wide wash of Pilarcitos creek, the sixty-foot sweep of its elliptical arch presents a monolithic span of im-

pressive proportions. Of the yearly thousands traveling this highway few are aware that this Half Moon Bay bridge is anything more than just another of San Mateo County's permanent highway installations; but, to those familiar with its history, it is a notable exception, actually a monument to pioneer architectural engineering, claimed for distinction as the world's first steel-reinforced concrete structure.

According to the records of San Mateo County on file in the Courthouse at Redwood City, plans

and specifications for this Half Moon Bay bridge were accepted and adopted by the Board of Supervisors on December 18, 1899 and on January 15, 1900, contract for the construction of the bridge in accordance therewith was awarded to R. C. Mattingly, contractor of San Francisco. By late spring of the same year the bridge was completed and opened to traffic. Since then—47 years to date, 1947,—it has remained opened and in continuous use, and without repair other than usual surface road work.

So far as known, this Half Moon Bay bridge is the first steel-reinforced concrete structure ever constructed anywhere in the world, states Curtis Tobey, Architect of the bridge and claimant of original design of structural reinforced concrete. Although first to be constructed, and thus entitled to the distinction, this Half Moon Bay bridge was not the first structure of its kind to be designed. Again referring to the records of San Mateo County, on August 15, 1898, Patrick McEvoy, then Chairman of the Board of Supervisors, presented to the Board my preliminary design for a 33-foot span steel-reinforced concrete highway bridge proposed for construction over Bear Gulch creek south from the town of Woodside. On September 6, 1898, the Board approved and adopted my working drawings and specifications for the construction of this Woodside bridge, and called for contractor's bids.

During the Board's prolonged consideration of these bids, I was called into conference with Joseph Debenedetti, Supervisor from the Half Moon Bay district, concerning the design of a similar but longer and more complex highway bridge proposed for construction over the wide sandy wash of Pilarcitos creek at Half Moon Bay. Due to unusual problems involved in the abutment foundations of this bridge, I invited Davenport Bromfield, C. E., of San Mateo, former County Surveyor, to join me in my work as surveyor and consulting engineer. Thus, on December 18, 1899, as stated, the Board of Supervisors accepted and adopted the drawings and specifications for the construction of the Half Moon Bay bridge, prepared by myself as Architect thereof, and Davenport Bromfield as Engineer.

During the time this Half Moon Bay bridge was under construction, and again with Mr. Bromfield as consultant, I designed the 40-foot span of the El Cerrito highway bridge located over El Cerrito creek at El Cerrito westward from the City of San Mateo. This was the second of the three San Mateo County steel-reinforced concrete highway bridges constructed during the year 1900, the third and last was the first I designed in 1898—the Woodside bridge.

Previous to 1898 and my design of these bridges

structural reinforced concrete was wholly unknown. I had only theory with which to work, and that theory my own,—I could find no precedent. Oddly enough and by chance, I obtained my first ideas from the common wax candle and the child's short stick of popular rock-candy. In unsuccessful attempts to break the candle and the stick of rock-candy, I found that the wick imbedded in the candle and the string in the stick of candy acted in tension to resist breakage, while the wax and the candy reacted in compression, crushing under the breaking stress. These observations led to experiments with old steel wire embedded in cement concrete, from results of which evolved my theory of structural steel-reinforced concrete. Opportunity to demonstrate this theory in actual construction came when I was employed as Architect for the Woodside bridge but as events transpired, initial demonstration occurred in my design of the longer and more complicated Half Moon Bay bridge, first to be constructed.

Further interest is attached to this Half Moon Bay bridge, and to the two later-built bridges, by the fact that all steel reinforcements used in their construction were cut sections of the old 1½-inch wire cable withdrawn from use in the slot of San Francisco's famed California Street Cable Railway.

---

#### WORKERS NEEDED IN BUILDING TRADES

Concerted cooperative effort by the construction industry, labor organizations and the Federal government to insure an ample supply of trained building trades workers for the heavy volume of construction expected in 1947 was recently urged by Douglas Whitlock, chairman of the Building Products Institute.

"There need be no shortage of workers to build homes and other structures if the apprentice training program is expanded and young men are interested in the building trades," Whitlock said.

Fully one-third more workers will be needed in 1947 than were available last year if the \$19 to \$20 billion of anticipated construction is to be accomplished this year, Whitlock pointed out.

"Additional workers are needed in every major building trade, both because relatively few young men entered the various trades during the depression and war years and because many of the union members are reaching retirement age," Whitlock concluded.

---

#### POPULATION

"If San Francisco had the same population density as New York County, the city would have 3,800,000 inhabitants," G. L. Fox, manager of the San Francisco Chamber of Commerce industrial department stated recently.



AIR VIEW OF JUDSON PACIFIC-MURPHY CORPORATION STEEL PLANT AT EMERYVILLE

# New Judson Pacific Murphy Steel Corporation Plant

Emeryville, California

Early this year the Judson Pacific-Murphy announced the consolidation of all offices, facilities and plants in one location at Emeryville, California.

The move returns to Emeryville the oldest steel fabricating plant in the West, as the origin of this company dates back to the pioneer days of California.

Seventy-nine years old in experience, the Judson Pacific-Murphy Corporation has written history on the West Coast in the fabrication and erection of structural and reinforcing steel for a large number of the west's most outstanding structures, but it is still young in industrial strength and recep-

tive to new ideas and, as is evidenced by their new plant embodying the most modern equipment and facilities, the company is ready to accept the challenge of the progressive West.

The formation of the present company was accomplished through the consolidation of the Judson Manufacturing Company and the Pacific Rolling Mills in 1928 and the further consolidation of the J. Philip Murphy Corporation at the conclusion of World War II, thus bringing together three companies diversified in specific activities in the steel industry.

The experience gained from solving problems encountered during the development of the west

by these companies is a potent part of the present corporation's equipment; and proof of the implicit faith of its officials in the future of steel fabrication as related to the west coast, is this completely modernized plant.

Although elastic in its ability to produce any type of structure involving steel, its principal operations are adapted to the design, fabrication and erection of all types of structural steel, to the fabrication of all forms of reinforcing steel and to the manufacturing of electric traveling cranes.

Upward to  $\frac{3}{4}$  of a million dollars have been spent by this corporation during the past twelve months completely modernizing the new plant in Emeryville. New structures added to the existing plant consist of a large machine shop fully equipped with the latest machinery required, three new large stock bays for plain material, a completely new reinforcing steel fabricating shop, a large addition to the existing structural steel fabricating shop and a modern office building. Approximately 390,000 square feet are now under roof and some six hundred people are consistently employed by this firm. Its capacity, facilities and personnel make it one of the largest operations of its type west of the Mississippi.

The new modern office building is three stories, first floor being occupied by executive and general offices, second floor confined to the structural steel

and crane divisions (both engineering and detailing) and the third floor to the reinforcing steel division.

This company is headed up by the following officials and department heads: P. F. Gillespie, President; J. Philip Murphy, Executive Vice-President; L. A. Peck, General Sales Manager; G. F. Rotenkolber, Assistant General Manager in Charge of Production; R. A. Fairbairn, Manager of Crane Division; E. O. Burgess, Chief Engineer of Structural Steel Division H. A. Emmrich, Chief Engineer of Reinforcing Steel Division; C. B. King, Chief Engineer of Crane Division T. A. Maas, Treasurer; W. T. Merriman, Secretary.

All of these men having had years of experience in the steel industry of the west, it is readily understood why everyone predicts that this corporation will write many more chapters in the development of the west coast.

### New Heating System

The Judson Pacific-Murphy Corporation's new office building, on the East Bay Highway terminal of the San Francisco-Oakland Bay Bridge, is completely equipped with automatic electric space heaters manufactured by the Wesix Electric Heater Company of San Francisco. Installation was made by the Enterprise Electric Company. The heater

(See Page 40)

**MODERN DESIGN BUILDING—**  
Houses general offices and executive headquarters.

J. Howard Hawk, Photo



# Tomorrow's House Today!

## San Francisco Home of Mr. and Mrs. Richard Walberg

A house designed for truly modern living is the home of Mr. and Mrs. Richard Walberg, 16 Spruce Street, San Francisco. Because of well-planned lighting and full use of electrical conveniences, it is an outstanding example of the functional home built for utmost comfort and utility.

Besides providing for the desired electrical installations, Architects J. Francis Ward and John S. Bolles encountered an interesting problem presented by an L-shaped lot. The lot slopes steeply to Pacific Avenue, overlooking the San Francisco Presidio, with a frontage of 45 feet and a depth of



### Architects:

**J. Francis Ward  
John S. Bolles**

**ENTRANCE**



**AN ATTRACTIVE VIEW OF INTERIOR COURT**

100 feet. At the top is the arm of the "L", a strip 12 by 80 feet extending to Spruce Street. There was a height limitation on the roofline of 35 feet above Pacific Avenue.

The architects' solution was a house designed on three levels, with the entrance at the top of the lot, approached by a stone-walled drive from Spruce Street, and the service entrance at the bottom on Pacific Avenue.

On the top level are the living room, den, guest room, dining room, kitchen, dinette, laundry and

garage. A short flight of stairs leads down to the master bedroom with adjacent dressing room and bath, the bedroom of the owners' young son Richard, with connecting bath, and an open-air patio. The maid's bedroom and bath has entrance from the service stairway.

The utility room on the lowest level has provision for a workshop with power tools and the son's electric train in addition to the furnace and other equipment.

**FIRST FLOOR  
PLAN**





**TOP—Second Floor Plan.**

**LEFT—**For reading in bed, pin-hole spotlights recessed in the ceiling; beams are cast at an angle. General lighting from cove over antiqued mirror.

**BELOW—Basement Plan.**

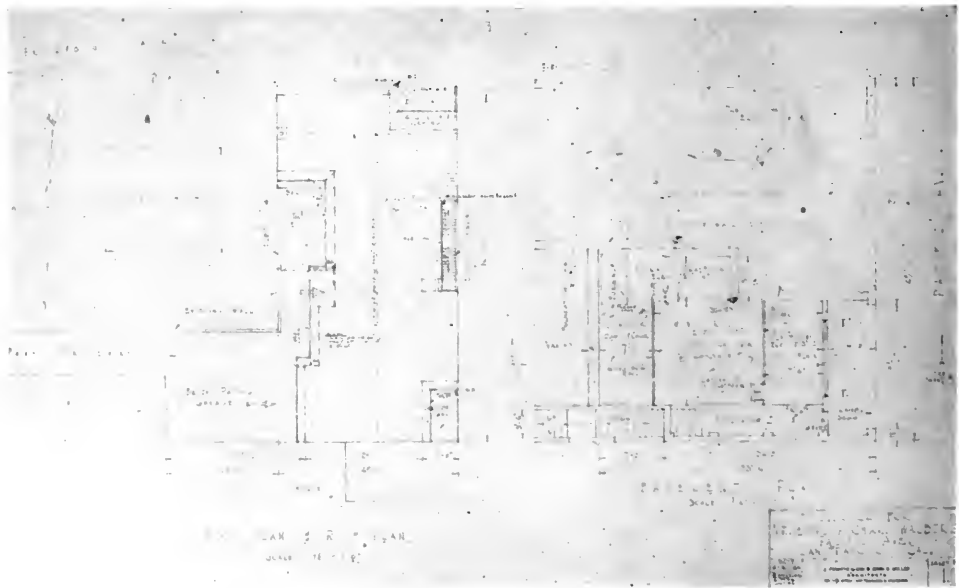





**ABOVE**—A recessed fluorescent fixture sheds soft general light in the dining room, and pinhole spotlights at either end give the table setting sparkle.

**BELOW**—Long Section of Floor Levels.

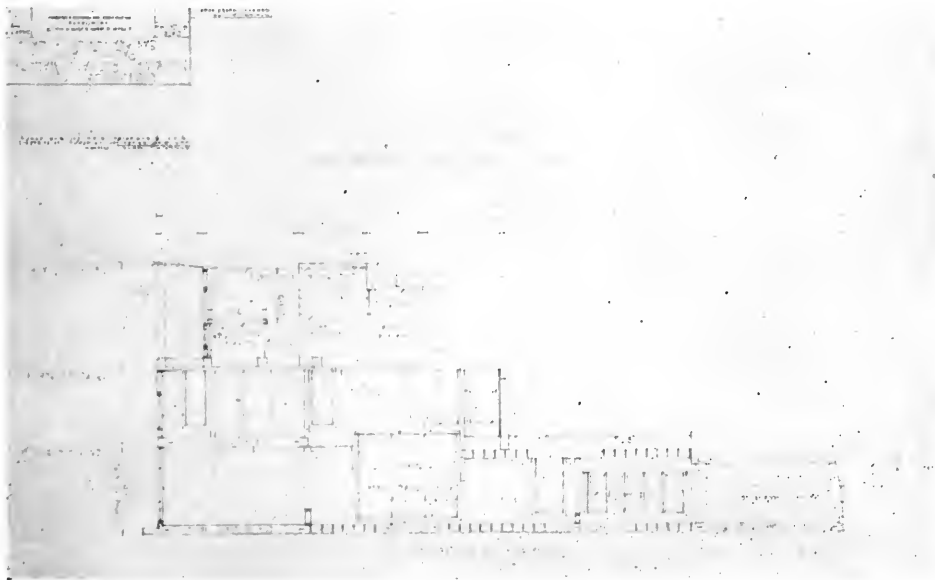



Decorative table and floor lamps are coupled with recessed spotlights for lighting in the living room (above) and the den adjoining it.





**RIGHT**—The dressing room adjoining the master bedroom has fluorescent lighting in coves around three sides of the full wall mirror over the mirrored dressing tables.

Constructed in every detail with thoroughness and care, the Walberg house will still be modern many years hence, a credit to its builders and a source of pride to its owners. To say that it has no fewer than 213 electrical outlets and plug receptacles, served by 46 circuits, gives an idea of how thoroughly the house has been designed for electrical living, not only now but for the future.

Electrical conveniences, personally selected by Mrs. Walberg, contribute to ease of living every-

where in the house. Mr. Walberg, of the construction firm of Swinerton and Walberg, was the builder. The wiring design was laid out by Harold A. Wright, consulting engineer engaged by Architects Ward and Bolles, and the installation was by Victor Lemoge. Douglas Baylis, landscape.

The first evidence of the Walbergs' planning is automatic operation of the garage door, controlled by a magnetic signal at the touch of a button on

(See Page 32)



**LEFT**—The kitchen has general lighting provided by a recessed fluorescent troffer unit. The range is pinhole spotlighted. Daylight is admitted through glass block panels concealed beneath the cabinets. Many other ultra modern items are included.



**BABY SHOP . . . ONE OF MANY "SPECIALIZED" DEPARTMENTS**

# Andrew Williams Store

## Oakland, California

**DOUGLAS DACRE STONE & LOU B. MULLOY, Architects**

When the new Andrew Williams Store in Oakland, California, was opened to the public recently, it represented considerably more than just one of the most extensive merchandise centers in California and the Pacific Coast.

This amazing, ultra modern, supermarket which is located at the intersection of Broadway and MacArthur Boulevard in downtown Oakland, is conceded to be the most unusual shopping center ever built, and in its present form was constructed on the site of a large business concern without a single interruption to normal business activities.

The architects, and management of the firm, carefully planned every step in the program, coordinating remodeling and new construction work to coincide with merchandising changes, seasonal sales activities, and enlargement of merchandise stocks.

Excavations for new buildings, construction of entirely new store units, and reconstruction of existing structures were made at no interruption of usual service to the public.

### ANDREW WILLIAMS STORE OAKLAND, CALIFORNIA

ARCHITECT: Douglas Dacre Stone & Lou B. Mulloy  
 GENERAL CONTRACTOR: Elmer J. Freethy  
 PAINTING (Interior): Sam Mazza  
 ELECTRICAL: Pacific Electrical & Mechanical Co. Inc.  
 SHOWCASE: Royal Showcase & Fixture Co.  
 WOOD PRODUCTS: J. di Christina & Son  
 ALUMINUM TRIM: C. E. Toland Co.  
 LIGHTING: Leader Electric Company  
 EXCAVATION: Ariss-Knapp Company  
 PAINT: Doidge-Koren Paint Co.  
 STRUCTURAL STEEL: Independent Iron Works, Inc.  
 PHOTOS: John Lohman.

The renewing, remodeling, and construction program required a total of 18 months and in its present form of 45,000 square feet of floor space, contains some 25 individual departments.

Each of the departments, including a bakery, home appliance, candy, Mexican food, women's apparel, florist, children's wear, photography, shoe

MODERN



ENTRANCE

and watch repair, beauty salon, drugs, camera and photographic supply, grocery, meat, delicatessen, liquor, produce, household goods and novelties, tobacco and news, and several others, all required special consideration in their placement in relation to each other and in their construction so as to command public attention.

A great many of the newest developments in commercial design are embodied in departmental settings throughout the store, and incorporated in practically each department is some special fea-

ture of merchandising sales appeal emphasized by the use of newest building products and materials.

Another feature of the store is the "Kiddies Park," uniquely decorated with Walt Disney characters. Here shopping mothers may leave their children without charge, while they shop at leisure throughout the store.

Also included in the new Andrew Williams Store is a complete, coordinated program of interior decoration.

THE APPLIANCE CENTER . . . FOR HOME APPLIANCES





ABOVE: The new Jewelry and Watch department has been designed for maximum display of merchandise in minimum amount of space, with ample space for customers and employees.

BELOW—Unique design, comfortable accommodations, and liberal use of mirrored-indirect lighting in the Cocktail Lounge.





**ABOVE VIEW**—Shows the Drug Store, with its modern display areas and show cases. Indirect overhead lighting gives ample lighting throughout store, while floor covering has been designed in keeping with ultra modern merchandising methods.

**BELOW**—A section of the Store where show cases have individual show-case illumination. Finished in natural Maple. Prefabricated booths in the adjacent Beauty Salan have a 2-inch thick, smooth finish, masonite wall.

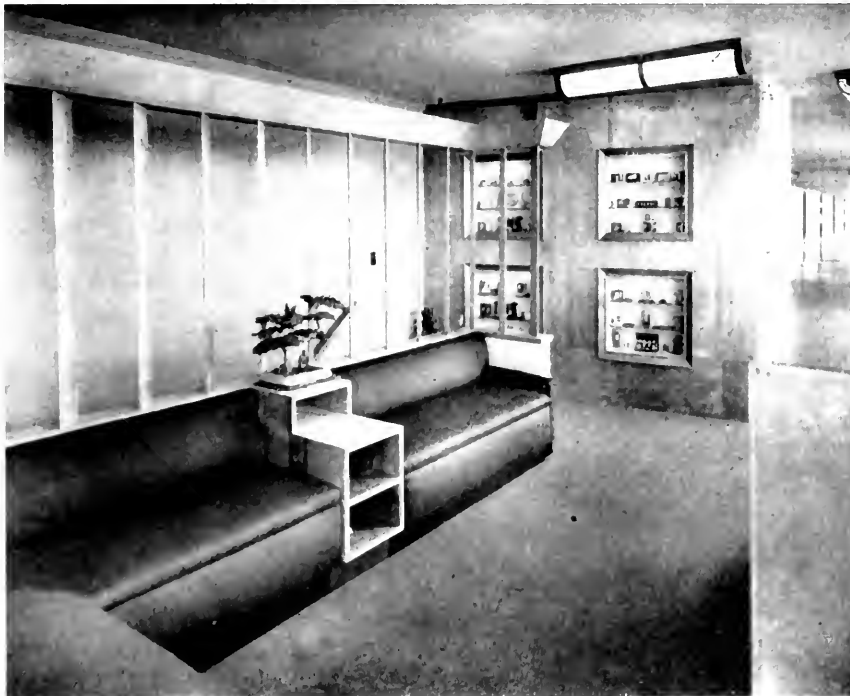



DINING ROOM—Unusual side-wall design and overhead construction

BELOW is shown the Floor Plan

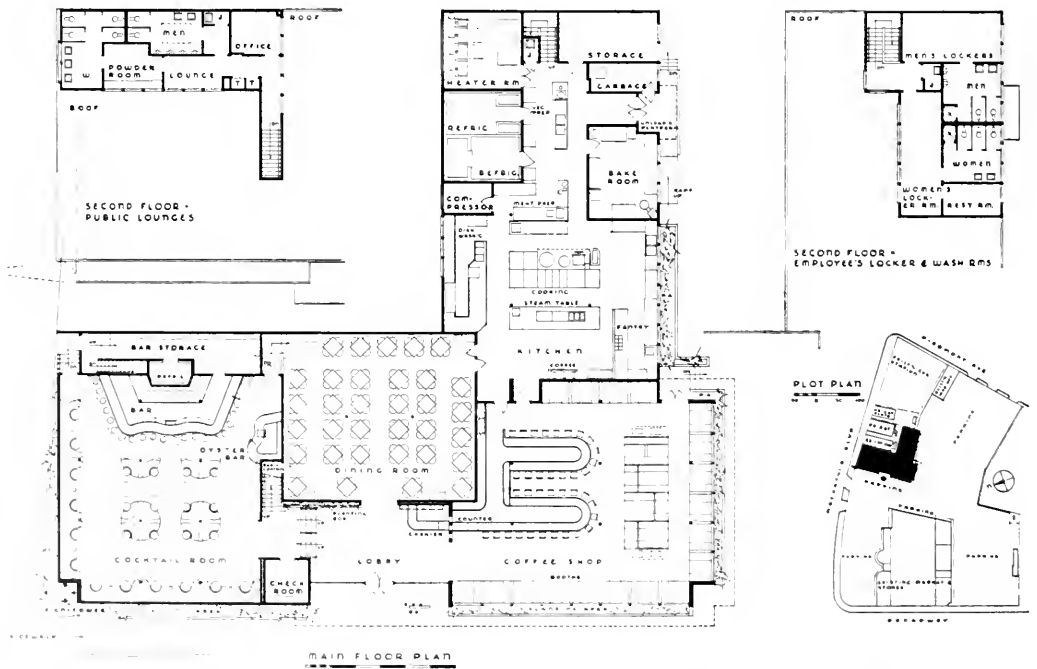

PLANNED'S RESTAURANT BUILDING - OAKLAND, CALIFORNIA  
DOUGLAS DICKER STONE AND LOU S. MULLOY - ARCHITECTS - SAN FRANCISCO, CALIFORNIA



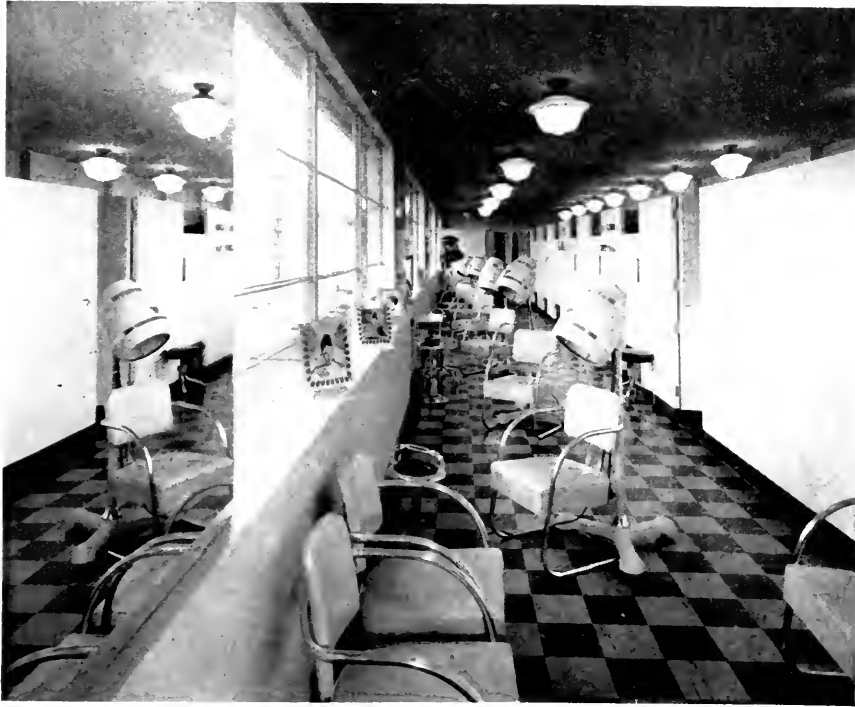

INTERIOR of  
Beauty  
Salon

INTERIOR DETAILS of Restaurant and Lunch Counter



# INTERIOR PAINTING

for the

**ANDREW WILLIAMS STORES**

by

**SAM MAZZA**

**Interior Decorating  
Painting Contractor**

PHONE DELAWARE 6360

414 HEARST AVENUE

SAN FRANCISCO

*We are proud indeed that DOIDGE - KOREN  
PAINTS were selected and while regular  
washable wall finish and egg-shell enamel  
were used, they were specially colored by us  
to specification of Mr. Sam Mazza, the deco-  
rator for the Andrew Williams Stores.*



**DOIDGE - KOREN PAINT CO.**

Manufacturers of

**ARCHITECTURAL - INDUSTRIAL - TECHNICAL  
FINISHES**

70 Alemany Blvd., San Francisco

ATwater 1133

The New

**ANDREW WILLIAMS STORE**

Is One of Our Contracts

**ELMER J. FREETHY**

*General Contractor*

Oakland and Richmond, California



HOME APPLIANCE DEPARTMENT, Andrew Williams Store

# ELECTRICAL CONTRACTORS

For the new

## ANDREW WILLIAMS STORE

Oakland, California

Installed by

### Pacific Electrical & Mechanical Co., Inc.

16th Street at Vermont  
San Francisco 3  
HEmlock 5904

400 So. Boylston Street  
Los Angeles 13  
MAdison 7641

# STORE FIXTURES

for  
BEAUTY PARLOR  
and  
CANDY SHOP

by  
ROYAL SHOWCASE CO.

SAN FRANCISCO

Agents for  
"KLEER-VU" METAL DOORS

Manufactured by  
THE RELIANCE ART METAL CO.  
CINCINNATI, OHIO

# ANDREW WILLIAMS STORE

## J. di CRISTINA & SON

Wood Products  
Stair Builders

350 Treat Avenue  
San Francisco

Phone  
HEmlock 8111

# ALUMINUM TRIM

for the

## ANDREW WILLIAMS STORE

by

### C. E. TOLAND COMPANY

*Metal Craftsmen*

BRONZE STAINLESS ALUMINUM  
334 RITCH ST. YUkon 6-4103 SAN FRANCISCO

Look to Leader for America's Finest Line of Fluorescent Luminaires

---

LIGHTING

BY

*Leader*

ANDREW  
WILLIAMS  
STORE

The Pacific Coast's Largest and Newest Store

Oakland, California

LEADER ELECTRIC COMPANY

2040 LIVINGSTON STREET

OAKLAND 6, CALIF.



**INTERIOR DESIGN**—Showing detail of doors and entrance-way to the Candy Shop, also smooth line of display fixtures at the side of the doors. Bright indirect overhead lighting adds to the attractiveness of the doorway.

(See Page 38)

**EXCAVATION**  
*for the*  
**ANDREW WILLIAMS STORE**  
*by*  
**ARISS-KNAPP CO**

961 - 41st Street

Oakland, Calif.

**STRUCTURAL STEEL FOR ANDREW WILLIAMS STORE BUILDING  
FABRICATED AND ERECTED BY . . .**

MANUFACTURERS OF STEEL BUILDINGS • BRIDGES • TOWERS  
FABRICATED STRUCTURAL STEEL • MISCELLANEOUS IRON  
STEEL SERVICE STATIONS • SHEET METAL PRODUCTS  
TANKS AND PLATE WORK • STEEL DISTRIBUTORS

**INDEPENDENT IRON WORKS INC.**  
EIGHTH & PINE STREETS  PHONE TEMPLEBAR 2-0160  
OAKLAND 7, CALIFORNIA

## FORDERER CORNICE WORKS

Manufacturers of

Hollow Metal Products • Interior Metal Trim  
Elevator Fronts and Cabs  
Metal Plaster Accessories • Sanitary Metal Base  
Flat and Roll Metal Screens  
Metal Cabinets • Commercial Refrigerators

269 POTRERO AVE.

SAN FRANCISCO, CALIF.

HEMLOCK 4100

## STRUCTURAL STEEL

For Class A Buildings,  
Bridges, etc.

**JUDSON PACIFIC - MURPHY CORP.**

4300 EASTSHORE HIGHWAY  
EMERYVILLE, CALIF.

## VALUABLE NEWS SERVICE

- BUILDING MATERIAL DEALERS
- CONTRACTORS
- ENGINEERS
- FINANCIAL INSTITUTIONS

**ARCHITECTS REPORTS** gives advance news on construction projects in Northern California, lists: name of projects, location, architect, proposed cost and other pertinent information.

**HANDY** individual slip-reports, issued daily at a total cost of only

\$10 a month

## ARCHITECT'S REPORTS

Published Daily

The ARCHITECT and ENGINEER, Inc.

68 Post Street, San Francisco - DO 8311

## TOMORROW'S HOUSE TODAY

(From Page 21)

the dashboard as the car enters the driveway. The magnet that closes the circuit is sunk in the concrete driveway.

Many steps are saved by voice intercommunication equipment wired throughout the house. Master stations, which permit initiation of calls, are located in the kitchen, living room, den, master bedroom, son's bedroom, and basement workshop. Auxiliary stations are located at the front door, in the guest room, and in the servant's bedroom. Conversations with the latter three stations must be initiated at one of the master stations. The equipment consists of near grilled speakers set flush in the wall and selector switches in panels labeled with the names of the stations.

The heating is by automatic hot water boiler with convectors in the rooms partially recessed. The gas-fired boiler is electrically controlled and required a special circuit. The son's bedroom has an indirect heating system with fan, the air being warmed by passage over hot water coils, and conduit and a switch were provided for future installation of a Westinghouse Precipitron. This will remove dust from the air by electronic precipitation before the air is circulated to the room.

Another measure for cleanliness and health is the installation in the bedrooms of germicidal lamps producing ultra-violet radiation. These are mounted above eye level inside shields that prevent exposure of the occupants to the direct rays.

For quick warmth on chilly mornings, ultra-violet sun lamps are installed flush in the ceiling of three bathrooms, over the washbasin in two and over the tub in the other.

The kitchen is a model of convenience. Designed for ample working space, it has long food preparation counters lighted both by fluorescent lamps concealed beneath the cabinets and by panels of glass blocks in the wall to admit daylight. Additional light on the work centers is provided by spotlights recessed in the ceiling. Installed under the cabinets in plug-in strip for unlimited use of small electrical appliances. Between the kitchen and dining room is a butler's pantry with auxiliary sink and additional work counters provided with convenient outlets. An outlet near the ceiling was provided for an electric clock.

The main sink is equipped with a garbage Disposall. The range is vented and there is a fan driven by a quarter horsepower motor for removing fumes. A one-inch conduit with three No. 6 wires was laid for the electric range. A kitchen desk is equipped with a telephone. Altogether there are five telephone outlets, the others being in the guest room, master bedroom, son's bedroom, and at a wall desk in the second floor hallway.

(See Page 42)



Arizona Chapter:  
 James Macmillan, President; Arthur T. Brown, Secretary,  
 740 N. Country Club Road, Tucson, Arizona.

Central Valley of California:  
 Herbert E. Goodpastor, President; Frank V. Mayo, Secre-  
 tary, 307 Exchange Building, Stockton 2, California.

Colorado Chapter:  
 Raymond H. Ervin, President; James M. Hunter, Secretary,  
 2049 Broadway, Boulder, Colorado.

Montana Chapter:  
 Ralph H. Cushing, President; H. C. Cheever, Secretary,  
 Montana State College, Bozeman, Montana.

Northern California Chapter:  
 Hervey P. Clark, President; Lester Hurd, Vice-President;  
 Ralph Pollack, Secretary; William C. Ambrose, Treas-  
 urer; 605 Market Street, San Francisco.

Oregon Chapter:  
 Francis Jacobberger, President; J. D. Annand, Secretary,  
 401 Central Building, Portland 5, Oregon.

San Diego Chapter (California):  
 H. Louis Bodmer, President; Louis J. Gill, Secretary, 203  
 Granger Building, San Diego, California.

Santa Barbara Chapter (California):  
 Roy C. Wilson, President; Miss Lutah M. Riggs, Secretary,  
 240 Middle Road, Santa Barbara, California.

CALIFORNIA COUNCIL OF ARCHITECTS  
 Vincent Palmer, President; Andrew Hass, Vice-Presi-  
 dent; A. C. Martin, Jr., Secretary-Treasurer; 369 Pine  
 St., San Francisco 4.

Southern California Chapter:  
 Adrian Wilson, President; A. C. Martin, Jr., Vice President;  
 Walter L. Reichardt, Secretary; George E. Gable, Treasurer;  
 Chapter Headquarters, 3757 Wilshire Blvd., Los Angeles 5,  
 California.

Spokane Chapter (Washington):  
 Noel E. Thomson, President; Kenneth D. Stormont, Secre-  
 tary, Hutton Building, Spokane, Washington.

Utah Chapter:  
 George Cannon Young, President; Theodore R. Pope, Secre-  
 tary, 29 South State Street, Salt Lake City 1, Utah.

Washington State Chapter:  
 George W. Stoddard, President; Stephen H. Richardson,  
 Secretary, 516 Central Bank Building, Seattle 4, Washing-  
 ton.

Hawaii Chapter:  
 Kenneth W. Roehrig, President; James Morrison, Secretary,  
 334 Federal Bldg., Honolulu, T. H.

**NORTHERN CALIFORNIA CHAPTER**

Consideration is being given the possibility of forming additional Chapters in the northern California area. The Executive Committee is now studying two groups. The East Bay group to consist of Alameda and Contra Costa counties, and the Coast Counties group to comprise the counties of Santa Clara, Santa Cruz, Monterey, and San Benito.

. . .

"Chapter Notes for June" is a "streamlined news sheet" designed to convey to Members, information of interest and necessity.

. . .

A special meeting of the Chapter was recently held on Hospital Design. Nat Owings, A. I. A., of Skidmore, Owings and Merrill; Marshal Schaeffer, A. I. A., Chief Architect of the U. S. Public Health Service; Dr. Askew of the California State Department of Health, and others spoke on the coming hospital program of the Federal government.

. . .

Wayne Hertzka, Chairman, has been extremely busy on the proposed San Francisco and Oakland "Professional License Tax". Other members of the Committee are Albert Evers, Wilbur Peugh, John Bolles, Edward Maher and Andrew Hass.

. . .

CHAPTER MEMBERS ADVANCED TO FELLOW-SHIP. The Chapter is proud of Members Jim Mitchell and Warren Perry who were advanced to the Fellowship at the Grand Rapids convention.

. . .

George Fred Keck, Architect of Chicago, gave an

illustrated talk before members recently on single family dwellings and his "solar" designs. Members of the Women's Architectural League were also present.

. . .

**EXHIBITION OF ARCHITECTURE AND TOWN PLANNING**

Regulations governing the Exhibition of Architecture and Town Planning to be held in connection with the Sixth Pan American Congress of Architects in Lima, Peru, provide that exhibits must be shipped about August 1st. At the last Congress this country received some 70 awards.

\_\_\_\_\_

**WASHINGTON STATE CHAPTER**

Professor Herrman of the Convention of the Associated Schools of Architecture, gave a detailed report of his impressions of the recent Institute Convention and Architectural Schools visited on his trip East.

. . .

NEW MEMBERS. Paul G. Carlson, Charles T. Miller, Waldo E. McKinney, and Byron F. Jacobson, while CHAPTER ASSOCIATES include Galen W. Bentley, Frederick R. Eley, Austin Grant, Barney E. Grevstad, George W. Hazen, Edward K. Mahlum, Bjarne C. Olsen, Leslie H. Peterson, Edward E. Sands, and Robert H. Wohleb.

. . .

The 508th Chapter meeting was recently held, sponsored by the Chapter's University of Washington Liaison Committee. U. of W. Architectural Alumni Association awarded prizes to winners of

(See Page 34)

# WITH THE ENGINEERS

Structural Engineers Association of Northern California

William W. Moore, President; John A. Blume, Vice President; Franklin P. Ulrich, Treas.; G. A. Sedgwick Sec.; Wm. H. Popert, Consultant; Office, Room 712, 57 Post St., San Francisco, Phone SUtter 5474. DIRECTORS, Mark Falk, M. V. Pregnoff, and R. D. Dewell.

American Society of Civil Engineers  
San Francisco Section

Theodore P. Dresser, Jr., President; Leon H. Nishikian and Sidney T. Harding, Vice Presidents; John E. Rinne, Secretary-Treasurer; 225 Bush St., San Francisco 20.

Puget Sound Engineering Council  
(Washington)

R. E. Kister, A. I. E. E., Chairman; E. R. McMillan, A. S. C. E., Vice Chairman; L. B. Cooper, A. S. M. E., Secretary; A. E. Nicholson, I. E. S., Treasurer; Offices, L. B. Cooper, c/o University of Washington, Seattle 5, Washington.

## AISC MOVES TO NEW SAN FRANCISCO OFFICE

The American Institute of Steel Construction, Inc., recently moved their district offices from the Russ Building, San Francisco, to suite 712, Mechanics' Institute Building, 57 Post Street, San Francisco 4.

## F.H.A. LOANS

TO BUY—  
REMODEL—  
REFINANCE

Long-term and low-cost F. H. A. loans are available to finance the purchase of homes already built, and to aid in the construction of new homes. Monthly payment F. H. A. loans on existing homes may be arranged for periods ranging up to 20 years. F. H. A. loans up to \$5400 on new construction may be made for as long as 25 years.

*For further information  
call at our Real Estate  
Loan Department*

**CROCKER FIRST  
NATIONAL BANK**

SAN FRANCISCO • OAKLAND  
*California's Oldest National Bank*

*Member Federal Deposit Insurance Corporation*

Publications of the A. I. S. C., technical data and general information concerning the structural steel fabricating industry may be obtained through the new office, according to William H. Popert, District Engineer.

## ENGINEERING AWARD

Dr. Raymond C. Martinelli, associate professor of mechanical engineering at the University of California, Berkeley, has been awarded the annual Melville Medal of the American Society of Mechanical Engineers.

The award is presented for the best original research paper on any mechanical engineering subject and was awarded to Dr. Martinelli for his subject "Heat Transfer to Molten Metals."

The award will be presented at the society's December meeting.

## AMERICAN SOCIETY OF MECHANICAL ENGINEERS

The 1947-48 President of the American Society of Mechanical Engineers will be E. G. Bailey, noted inventor in the combustion field and vice president of the Babcock & Wilcox Company of New York. Mr. Bailey was nominated for the office at the Semi-Annual Meeting of the Society recently held in Chicago and nomination is tantamount to election.

He will succeed Eugene W. O'Brien of Atlanta.

J. Calvin Brown of Los Angeles was named Regional vice president for division 7.

## STRUCTURAL ENGINEERS ASSOCIATION OF NORTHERN CALIFORNIA

A joint meeting with the Safety Engineers, sponsored by the San Francisco Engineering Council, recently heard Dr. Edward U. Condon, Director of the National Bureau of Standards, U. S. Department of Commerce, speak on the subject "Research at the National Bureau of Standards."

Many interesting phases of the Bureau's work were discussed.

New Developments in Connections—included a program of recently developed apparatus; explanations, illustrations and demonstrations

NEW MEMBERS, Leslie Joseph Meszaros has been elected a member; George E. Solnar, Jr., an Affiliate Member, and Fernando F. Herrero, a Junior Member.

Augustus V. Saph, Jr., has been appointed a member of the California State Board of Registration for Civil Engineers, replacing Mark Falk who resigned.



Joseph P. Haas, is now associated with the Metropolitan Construction Company, San Francisco.

\* \* \*

**ANNUAL CONVENTION.** The State SEA Convention has been tentatively set for October 10-11-12 at Yosemite Valley.

### **PUGET SOUND ENGINEERING COUNCIL**

The Council has published and distributed the new "Professional Engineers Registration Act" which regulates the practice of engineering and land surveying. The Act also defines terms and creates a State Board of Registration for Professional Engineers and Land Surveyors.

\* \* \*

**ISSUED LICENSES.** M. O. Anderberg, CE; W. L. Hoffman, ME, EE; E. H. Lindstrom, CE, and A. Shipek, EE, SE, of Seattle; J. A. Johnson, EE, of Bothell; R. E. Lee, EE, of Dayton; and M. Von Berlichingen, ME, CE, SE, HE, of New York.

### **PUGET SOUND CHAPTER AMERICAN SOCIETY FOR METALS**

W. E. Claflin, Welding Engineer for Ampco Metals, recently spoke on the subject "Copper Base Alloys", outlining the mechanical properties and composition of various copper base alloys. He also described the various grades of coated aluminum bronze electrodes which were developed to give weld deposits of varying degrees of strength, ductility, and hardness.

Following the paper a new color and sound film "Golden Horizons" showing the history and development of copper base alloys was shown by Lou R. O'Connor, Seattle representative of the Ampco Metals.

\* \* \*

Sustaining members were honored at a recent meeting of the Chapter, in appreciation for their support which has made it possible to offer educational opportunities in the field of metals.

Joseph Danials, Professor of Mining Engineering and Metallurgy at the University of Washington, was the speaker of the evening. The title of his subject was "Sustaining Metals."

### **WESTERN NEEDS**

It has been estimated in business and official quarters that new construction totaling \$20,000,000,000 is needed right now in the 11 Western States. At a rate of \$2,000,000,000 a year it would take 10 years to complete. By that time it is believed as much again would be lined up for future years.

# Plan for built-in telephone outlets



Even though only one telephone is needed initially, plan others for your client's future convenience.



Additional telephones may be added in future without tearing up the flooring or running wires along baseboards.



Convenience of well placed telephone outlets will be appreciated year after year.



Specify that telephone conduit be installed during construction. Adds little to building cost - adds real value to house.

Call your local Telephone Business Office. Ask for free Architects' and Builders' Service.

## The Pacific Telephone and Telegraph Co.



## A.I.A. ACTIVITIES

(From Page 31)

the Annual Alumni Prize Competition. A. I. A. Medals for excellency in design were awarded to Wendell Lovett and Richard Whitney.

The following officers were nominated for the ensuing year: Clinton J. Brady, president; Arrigo M. Young, vice president; John Richards, second vice president; Ralf E. Decker, secretary; Waldo B. Christenson, treasurer; Leonard Bindon, Executive Board 3 years; Edwin T. Turner, Executive Board 1 year.

### CALIFORNIA COUNCIL OF ARCHITECTS

The Second Annual Convention of the California Council of Architects will be held on October 1, 2, 3, and 4, 1947 at the Saint Catherine Hotel, Catalina Island.

The tentative program includes an open meeting with the California State Board of Architectural Examiners, a hospital seminar, and attendance by Architects from Oregon, Washington, Alaska and Hawaii.

### SOUTHERN CALIFORNIA CHAPTER

Delegates who attended the A. I. A. Convention at Grand Rapids, Michigan, report greater interest

among delegates than ever before, with a keen interest throughout the rest of the country in California.

Richard Neutra, F. A. I. A. has been made an honorary member of the Mexican Association of Architects, the Cuban Association of Architects, and the Bolivian Association of Architects. He has also accepted the invitation to serve as a judge in the nation-wide competition for the Jefferson National Expansion Memorial.

The Southern California Gas Company sponsored a recent meeting of the Southern California Chapter of the Producers Council, Inc., and the Southern California Chapter, A.I.A.

William Perira, Welton Beckett and Paul Williams are on a committee to cooperate with R. K. O. on technicalities pertaining to the Architectural Profession.

### JULIAN STEWART FAIRWEATHER, 69

Mr. Fairweather came to San Francisco before the 1906 fire and was associated with Bliss & Faville in construction of the Hotel St. Francis. He planned the Pacific Building, the Matson Building, Balboa Building, the State Building in the Civic Center, Women's Athletic Club, Western Women's Club, and the Hotel Oakland. The firm became known as Bliss & Fairweather.

### FIELD ARCHITECT APPOINTED

R. R. Young, has been appointed field architect for the Pacific division of the B. F. Goodrich Company with offices in Los Angeles, according to an announcement by James A. Holland, manager of store design and engineering.

Architects were also named to serve the company in four other divisions representing the entire country in program of improving salesrooms, rearrangement of store layouts, merchandise displays, fixtures, lighting and other phases of design.

### NEW CALIFORNIA ARCHITECTS

Following is a list of Architects who have recently been licensed by the California State Board of Architectural Examiners to practice in the state:

Alfred Adler, Dean L. Banta, Robert J. Betten-court, Sydney H. Brisker, Eugene F. W. Chin, Warren C. Erskine, Robert S. Kitchen, Silvio P. Mar-raccini, Germano A. Milono, William C. Sargeant, and Alexander Yuill-Thornton of San Francisco; Albert E. Alexander, Alameda; Paul H. Ayer, Bak-

**GOOD CONSTRUCTION DEMANDS**

**3 HINGES TO A DOOR**

PREVENT WARPING  
KEEP DOOR IN LINE

**STANLEY**

THE STANLEY WORKS, NEW BRITAIN, CONNECTICUT

The advertisement features a detailed illustration of a Stanley door hinge. A banner at the top reads '3 HINGES TO A DOOR'. Below the hinge, a small box of hinges is shown. The text 'PREVENT WARPING KEEP DOOR IN LINE' is written on a dark background at the bottom left. The Stanley logo is prominently displayed in a white box at the bottom center, with 'THE STANLEY WORKS, NEW BRITAIN, CONNECTICUT' written below it.

ersfield; Robert I. Baldwin, and Lloyd L. Mounts, Altadena; Kenneth B. Banks, and Craig A. Walsh, Alhambra; David E. Bean, Corte Madera; Raymond L. Blackwell, Hans U. Gerson, Edward B. Hussey, Ralph W. Jenson, Hans G. R. Schickele, N. W. Patterson, and Robert C. Williams, Berkeley.

Jacob J. Buchter, Orinda; Eugene K. Choy, Eldon C. Davis, Gunter E. R. Dorlig, David Freeman, Norman E. Kocher, Harry T. MacDonald, Arthur L. Minasian, Donald E. Neptune, Roland L. Russell, and Frank S. Young, Los Angeles; Francis A. Constable, and William H. Daseking, Menlo Park; Mal Joseph, Glendale; James A. Daley, Jean W. S. Hastings, and Lief J. L. Nielsen, Oakland; William W. Dickinson, Jr., Darwin E. Fisher, Keith P. Marston, Maxwell Mason, and James A. Murphey, Jr., Pasadena.

John A. Duffy, Long Beach; William Hastrup, and Robert W. Stevens, Fresno; Robert F. Hindinger, Inglewood; Arne A. Kartwold, Albany; George L. Lindeberg, Laguna Beach; Hollis L. Logue, Jr., Campbell; Bolton C. Moise, Riverside; John Robert Mosher, La Jolla; Howard H. Morgridge, Sierra Madre; Erling Olason, Sacramento; Burton Romberger, Arcadia; and Edwin A. Wadsworth, Burlingame.

#### **SAN FRANCISCO ARCHITECTURAL CLUB**

Ferdinand T. Kebely, industrial designer and plastics engineer, spoke before members of the group recently on the subject "Plastics."

Many new uses of plastic materials by architects were explained and numerous samples of work done by the speaker were shown.

Raymond L. Blackwell, Architect, will instruct a course in "Introduction to Architectural Design" for beginners in architectural design and to fulfill the requirements of the Atelier which requires a knowledge of the Orders, Shades and Shadows, and Perspective.

The course covers 15 weeks with a two hour lecture each week.

#### **DEAN ARTHUR B. GALLION**

The Association of Collegiate Schools of Architecture have named Dean Arthur B. Gallion of the University of Southern California a member of the executive committee of the Association.

The honor was conferred at the recent A. I. A. Annual Convention and includes direction of educational programs and the establishment of standards for universities over the United States.

#### **ARCHITECT BUREAU**

The Architect Association of the University of California is seeking part-time work or full-time employment for students.

Ward B. Whitwam, Berkeley, California, is serving as Employment Chairman.

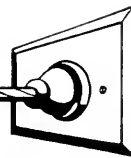

## **OUT-MODED WIRING-- A LIABILITY**

Homes built 20 years ago are electrically obsolete. Wired chiefly for lights and a few small appliances these homes lack the power for today's expanded electrical needs.

Bankers and other lenders, consequently, place wiring high on the list of factors to be checked as contributors to home depreciation and early obsolescence.

To protect the owner's investment, architects today are placing increased emphasis on adequate wiring — enough circuits of large enough wire, and plenty of conveniently placed outlets and switches — for all present and future needs.

### **NORTHERN CALIFORNIA ELECTRICAL BUREAU**

**1355 MARKET STREET  
SAN FRANCISCO 3**

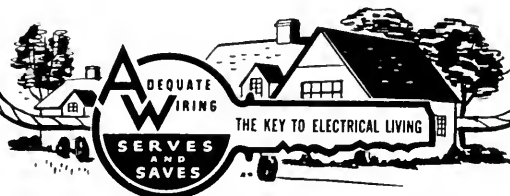

**BAXCO**  
CHROMATED ZINC CHLORIDE

**CZC**

**PRESSURE TREATED LUMBER**  
● **PROTECTS AGAINST DECAY  
AND TERMITE ATTACK**

*Specify it in your home  
Available through Lumber Dealers*

LOS ANGELES 601 W. 5th Street Phone Michigan 6294	SAN FRANCISCO 333 Montgomery Street Phone DOuglas 3883
---	--

**J. H. Baxter & Co.**

AGENTS FOR WEST COAST WOOD PRESERVING CO. SEATTLE, WASH.

"GOODS OF THE WOODS"  
**E. K. WOOD LUMBER CO.**

W

**LOS ANGELES**

HOLLYWOOD	SIERRA MADRE	UPLAND
PASADENA	TEMPLE CITY	LA VERNE
LONG BEACH	WHITTIER	SAN PEDRO
RIVERSIDE	ONTARIO	INDIO

**OAKLAND  
SAN FRANCISCO**

## ANDREW WILLIAMS STORE

(From Page 31)

"Sales visibility becomes unlimited by the intelligent use of color," and to prove this point interior decorations throughout exemplify the Andrew Williams Store, where specific uses of color are "tailored to fit" the background of completely unrelated commodities on display.

Throughout the entire store, containing some 45,000 square feet of floor selling area, various departments are indicated by harmonizing color demarkations, as for example the specialty shop merchandise is posed against a soft peach background, framed in off-white and set into a wall section of rose red. Every detail in this shop has been thoughtfully "color styled" even to the fitting rooms where the colors chosen have been further emphasized by careful use of smartly designed wall papers embodying the color scheme for this particular section.

The white enameled iron railings of the rear entrance to the building are sharply etched against rose red walls and balanced with a chartreuse base which leads to an upper floor.

The main floor displays of a wide variety of items, are superimposed on pale chartreuse flat surface backgrounds which extend the entire length of one side and are tied together with a deep band of rose red color, which in turn breaks into the huge wall space at one side of the grocery and frozen food section, offering an unusual variety in coloring from the usual clinical white used in most markets.

The wall color is joined at one end of the building by a solid bank of Venetian blinds which are done in pale canary yellow. The left wall side, broken up by individual displays, is done in soft light blue which deviates in shade through the upper sections on the mezzanine floor and are clearly seen through the large glass partitions facing the main market.

The area through the center section of the store, leading to the mezzanine, is painted in a soft turquoise green which ties the rose red wall, the canary yellow front section and the pale blue wall together in a remarkably pleasing manner.

The endless recombining of the original basic color selections is the interior decorator's formula for making the entire store an outstanding example of color design in modern merchandising methods.

### FORM PARTNERSHIP

James J. Walsh, Consulting Civil Engineer, and George H. Jennings, Structural Engineer, recently formed a partnership which will be known as Walsh, Jennings and Associates.

The new organization will maintain offices at 112 Market Street, San Francisco.

## IN THE NEWS

### HOSPITAL DISTRICT

The Sequoia Hospital District, near Redwood City, California, has voted \$1,500,000 for the construction of a 90-bed hospital building. Kingsford Jones of San Jose, is the architect.

### DETENTION HOME

The County of Yolo, California, has been granted a CPA permit for the construction of a new \$110,000 detention home near Woodland. W. D. Peugh, San Francisco, Architect.

### BARRACKS CONVERSION

Architects Anderson & Simonds of Oakland, have been selected to convert the former barracks and hospital buildings at Hammer Field, Fresno, into 246 family apartments at an estimated cost of \$519,723.

### MENTAL HOSPITAL

The Nevada State Mental Hospital, Sparks, Nevada, will include 2-ward buildings containing 100-beds. Architect Edward S. Parsons, Reno, estimates the cost of construction will be \$350,000.

### COUNTY JAIL

A \$146,700 addition to the County Jail and Courthouse at Oroville, California has received CPA approval. E. Geoffery Bangs, San Francisco is the architect.

### WESTERN PACIFIC

Ellis W. Barker, general contractors of Salt Lake City, Utah, have been awarded contracts for construction of new buildings for the Western Pacific Railroad at Elko, Nevada (\$50,000) and Winnemucca, Nevada (\$42,000).

### PENITENTIARY ADDITION

The Walker Boudwin Construction Company of Reno, Nevada, have been awarded a general contract for construction of an addition to the Nevada State Prison to cost \$475,000.

### CASKET FACTORY

The Sacramento Casket Company have been granted a CPA permit for the construction of an addition to their plant. Chas. F. Dean, architect, estimates cost at \$46,500.

# MADE RIGHT FOR BETTER LIGHT

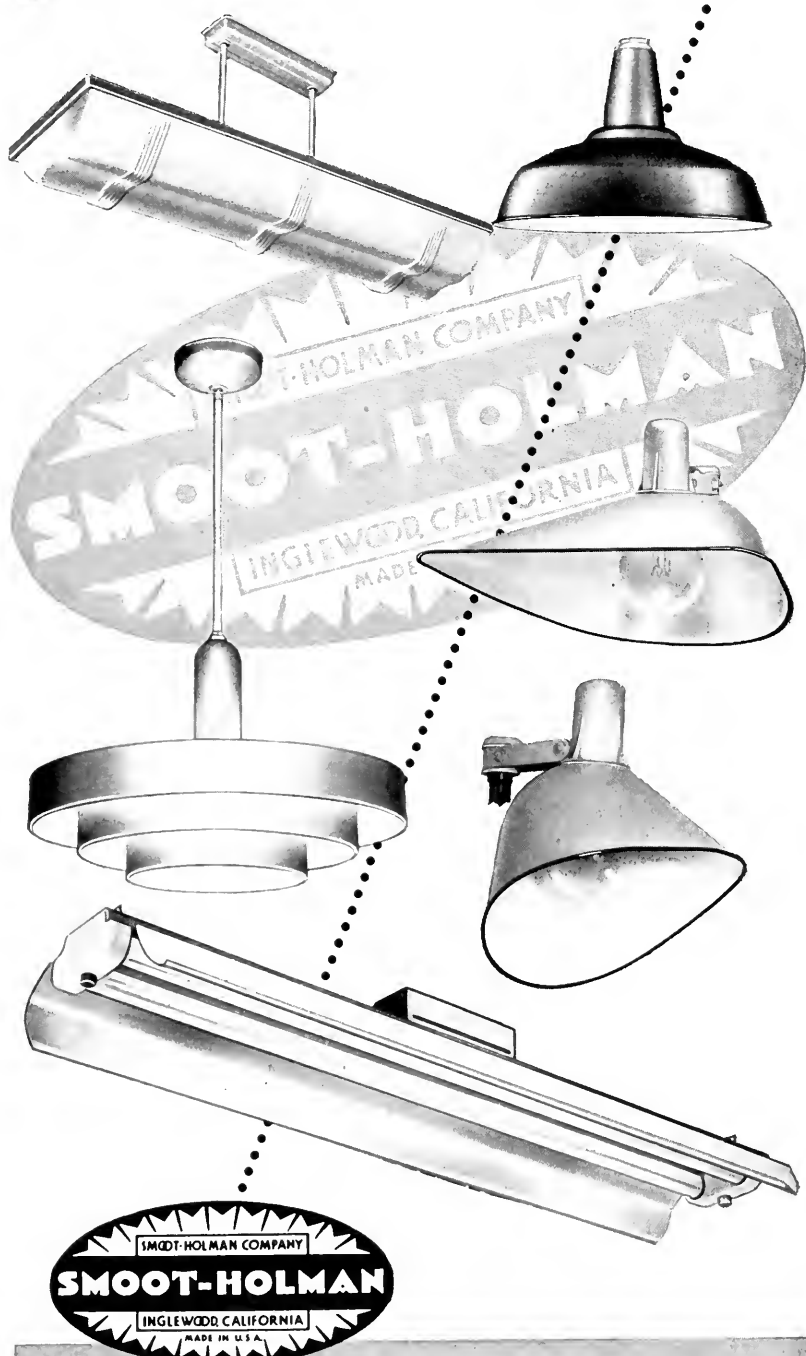

# NEW JUDSON PACIFIC-MURPHY STEEL CORPORATION PLANT

(From Page 15)

equipment is the largest of its kind and is unquestionably the forerunner of many similar installations.

The heating units are designed with a hollow chimney-like ceramic core with the electric element wound on the outside of the core. This design provides a natural circulation of warm air at the optimum speed of 200 linear feet per minute. Thermostates are built into the heater, a patented feature, and respond to the incoming cold air drawn from the floor over the bimetal coils of the thermostat.

The heating system offers greater economy of operation and installation over any other type of heating in this size building. There is no furnace room, furnace or expensive duct or pipe work required. Each room has its independent and automatic heating unit. Power is supplied from three banks of transformers, one on each floor, totalling 135 KVA.



**ABOVE ILLUSTRATION—Shows details of heating unit installations, in relation to floor and windows. Entire system is automatic controlled.**



**interior — Judson-Pacific-Murphy Corporation**

Operation of the heaters is left to the individuals occupying the rooms. There is practically no maintenance of this equipment since there are no moving parts, and expected life of the heating elements is indefinite. Many Wesix heaters have been in service over 20 years without any repair work or adjustment whatsoever. Relatively mild climate on the Pacific Coast area combined with low and simple electric rate schedules, makes it possible and practical for office buildings to use the advantages of cleanliness and convenience found in electric heating at minimum cost to the owner.

**ELECTRIC WIRING**

and

**WESIX ELECTRIC HEATER**

installation in

**JUDSON PACIFIC-MURPHY CORP.**

Office Building by

**ENTERPRISE ELECTRIC WORKS**

ELECTRICAL CONTRACTORS

1164 Mission Street, San Francisco

Market 4780

# IN THE NEWS

## NEWSPAPER PRESS BUILDING

The Oakland, California, Tribune is constructing a new press building at a cost of \$223,000.

## HOSPITAL ADDITION

A CPA permit has been granted for the construction of a 20-bed addition to the Municipal Hospital at Visalia, California. David H. Horn & Marshall D. Mortland, Fresno, architects estimate the cost at \$100,000.

## LANDSCAPE ARCHITECTS

Katy and Paul Steinmetz, Landscape Architects, recently announced the opening of new offices at R.F.D. Box 710, San Rafael, California.

## HIGH SCHOOL ADDITION

A reinforced concrete and frame addition costing \$156,000 will be added to the Arcata Union High School District, according to Masten & Hurd, San Francisco, architects.

## RICE STORAGE SILOS

A CPA permit has been granted for the construction of 17 rice storage silos in west Sacramento at a cost of \$194,695.

## AMERICAN LUMBER CONGRESS

Lumber manufacturers and fabricators from all parts of the nation, met in Chicago on June 16-18, to hear Under Secretary of Labor Keen Johnson; U. S. Senator Kenneth Wherry; Earl Bunting, president, National Association of Manufacturers; and Col. W. B. Greely, of the West Coast Lumbermen's Association, discuss industry problems.

## Some New Subscribers to Architect and Engineer

Modern Insulation Co., Arcadia, Calif.; P. F. Bridges, Contr., Stockton, Calif.; Minondo & Cordon, Archts., Guatemala; Laurence S. Hauser, Archt., San Francisco; G. P. W. Jensen & Sons, Contrs., San Francisco; Thomas & Meret, Archts., San Francisco. Chas. H. Kezer, Oakland, Calif.; F. L. Mitchell Co., San Francisco; A. E. Maassen, Los Angeles, Calif.

J. Richard Shelley, Long Beach, Calif.; Mr. John Hewitt, Tacoma, Wash.; Gordon M. Leupke, Archt., Tucson, Ariz.; Tri-State College, Angola, Ind.; Richard Johnson,

Charlestown, Mass.; John D. Freed, Scottsbluff, Neb.; William B. Griese, Williamsport, Pa.; Miss Julia Strauch, Bogota, Colombia; Engineers & Co., Ahmedabad, India; Mr. D. Jaspán, Transvaal, So. Africa; Leslie H. Crowder, Jr., Los Angeles, Calif.; Robert R. Reynolds, Vallejo, Calif.

Jas. R. Shinn, San Leandro, Calif.; Nelson & Rogers, Fresno, Calif.; Carl H. Guettler, Contr., Eureka, Calif.; Don Clarke, Contr., Stockton, Calif.; Ochs Construction Co., Fresno, Calif.; C. B. Goodwin, C. E., San Jose, Calif.; William E. Foster, Archt., Los Angeles, Calif.; Henry Jewell, Contr., Monterey, Calif.

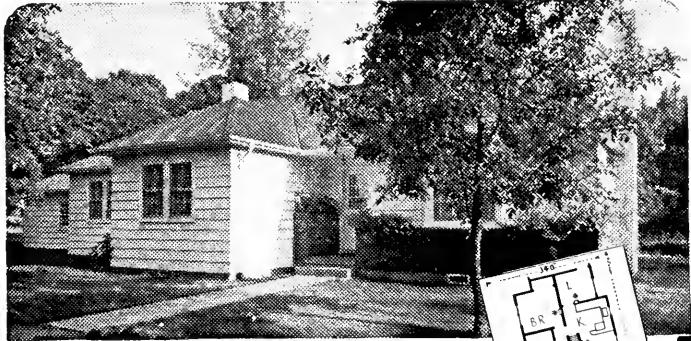

**\$74<sup>30</sup>** electric cost  
heated this 6 room home  
**ONE FULL YEAR**

This fine new all-electric home in Portland chose electric heat the WESIX way, for luxury and super-comfort. Yet its actual monthly bills for electric heating current show an economy that can hardly be surpassed by any known kind of heating plant.

**WESIX**  
*Wired heat*

gives this modern home many extra advantages at **NO GREATER COST**—full-automatic heat, adequate insulation, each room at temperature desired, warm floors, no cold drafts, no work tending heating plant, no soot nor dirt, less housecleaning and laundry, no smoke fumes nor burnt-out air, no uncertainty of fuel supply.

Cost records of other houses like yours are here for you to see. Perhaps they will show that you too can enjoy the luxurious comfort of electric heat in your home—plus economy. You incur no obligation by getting this cost data and our estimate on a complete Westix Electric Heating System installed.

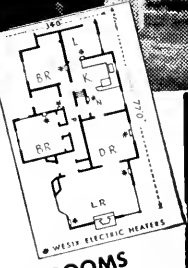

**6 ROOMS**  
**11,200 CU. FT.**  
actual cost for  
electric heating

Jan.	\$17.46
Feb.	13.66
Mar.	11.06
Apr.	8.06
May	8.26
June	.74
July	.88
Aug.	.00
Sept.	1.09
Oct.	4.73
Nov.	8.36
Dec.	

**ASK US** to lay  
out on  
your house plans a WESIX  
Electric Heating System.



**WESIX ELECTRIC HEATER CO.**  
390 First St., San Francisco

Please mail me your 20-page illustrated color booklet which shows many modern homes whose owners enjoy the luxurious comfort of WESIX electric heat at **NO GREATER COST** than for ordinary fuel. I enclose 10 cents in stamps to cover your cost of wrapping and mailing.

My Name \_\_\_\_\_  
Street No. \_\_\_\_\_  
or Rural Route \_\_\_\_\_  
City \_\_\_\_\_ State \_\_\_\_\_

## "AMERICAN - MARSH" CONDENSATION UNIT

Pumping  
Machinery  
for  
Every  
Purpose

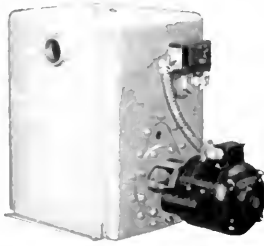

For Service  
Call  
DOuglas  
6794  
or  
MUtual8322

**SIMONDS MACHINERY CO.**  
SAN FRANCISCO 816 FOLSOM  
LOS ANGELES 455 EAST 4TH

## VERMONT MARBLE COMPANY

Producers and Finishers  
of  
Domestic and Imported Marbles

525 MARKET STREET, SAN FRANCISCO  
Phone Sutter 6747  
3522 COUNCIL STREET  
(Beverly Blvd. at Virgil Ave.)  
LOS ANGELES 4, CALIF.  
Telephone Fairfax 7834



**The Most Complete Line of  
STEELS and BUILDING MATERIALS  
Made by a Single Producer**



See Sweet's Catalog File or write us for  
full information.

**REPUBLIC STEEL CORPORATION**  
GENERAL OFFICES: CLEVELAND, OHIO

DENVER, COLORADO . . . . . CONTINENTAL OIL BUILDING  
LOS ANGELES, CALIFORNIA . . . . . EDISON BUILDING  
SALT LAKE CITY, UTAH . . . . . WALKER BANK BUILDING  
SAN FRANCISCO, CALIFORNIA . . . . . RIALTO BUILDING  
SEATTLE, WASH. . . . . WHITE-HENRY-STUART BUILDING

## PACIFIC MANUFACTURING CO.

HIGH CLASS INTERIOR FINISH  
QUALITY MILLWORK

142 SANSOME ST., SAN FRANCISCO  
GARfield 7755

6820 MCKINLEY AVE., LOS ANGELES  
THornwall 4196

BUILDERS EXCHANGE, OAKLAND

## TOMORROW'S HOUSE TODAY

(From Page 32)

Off the kitchen is the laundry, in which the automatic washing machine will later be matched by an electric drier. Opening from the laundry is a large built-in home freezer with wide storage shelves and full-length doors.

Not the least of the electrical features of the Walberg house is the lighting, which was designed to contribute to the rooms' spaciousness, accent their beauty, and provide adequate levels of illumination for all seeing tasks.

White fluorescent lamps in flush troffers with wide spread Holophane lenses have been employed throughout, supplemented by numerous inset pinhole spotlights. In the master bedroom, spotlights on either side of the bed cast beams at an angle for comfortable reading in bed. Similar reading lights are installed over the bed and over a couch in the son's room. The full wall mirror of the dressing room is lighted on three sides by white fluorescent lamps in coves. The shower stall light is enclosed in a waterproof globe.

Pin-hole spotlights are used at each end of the fluorescent unit over the dining table to accent the table setting. There is a spotlight to light the music on the grand piano in the living room, and another over the card table in the den. A built-in bar in the den is equipped with fluorescent lighting, hot water, and a remotely controlled refrigerator.

All closet lights are operated by door switches. there are numerous three and four-way switches. All wall switches are of the mercury type, which are silent and can never wear out. A drop of mercury rolls into place to make electrical contact when the lights are switched on. When lights are off, the switch plates are visible in the dark, lighted by small neon glow lamps. At the front door is a keyhole light. The driveway is lighted by incandescent lamps set into the stone wall, and the house number in the end of the wall is lighted.

One of the good features of the wiring is the use of Class 1 circuit breakers in place of fuses. There are three panels, the main one in the basement having 8 circuits and those on the first and second floors 12 and 26 respectively. The distribution circuit wiring is No. 12 or larger, carried in flexible steel conduit and metallic tubing. The main feed is underground and consists of 3 conductor No. 4 0 wire insulated with varnished cambric and sheathed in lead. This exceptionally heavy feed provides capacity for future additional electrical appliances and lighting. The house has 129 outlets, 84 plug receptables, and 94 switches.

With the careful attention given to all details of the house, it is certain not to become "outgrown" in any near future, as is the fate of too many houses now being built. Truly, the Walberg residence is "Tomorrow's house today."



# ESTIMATOR'S GUIDE

## BUILDING AND CONSTRUCTION MATERIALS

PRICES GIVEN ARE FIGURING PRICES AND ARE MADE UP FROM AVERAGE QUOTATIONS FURNISHED BY MATERIAL HOUSES TO SAN FRANCISCO CONTRACTORS. 2½% SALES TAX ON ALL MATERIALS BUT NOT LABOR

All prices and wages quoted are for San Francisco and the Bay District. There may be slight fluctuation of prices in the interior and southern part of the state. Freight cartage, at least, must be added in figuring country work.

**BONDS**—Performance—\$10 per \$1000 of contract. Labor and materials, \$10 per \$1000 of contract.

**BRICKWORK**—

Common Brick—Per 1M laid—\$80.00 to \$100.00 (according to class of work).

Face Brick—Per 1M laid—\$150 to \$200 (according to class of work).

Brick Steps—\$2.30 per lin. ft.

Brick Veneer on Frame Bldg.—Approx. \$1.50 per sq. ft.

Common Brick—\$26.00 per M, truckload lots, f.o.b. job.

Face Brick—\$60 to \$100 per M, truckload lots, delivered.

Cartage—Approx. \$5.00 per M.

**BUILDING PAPER**—

1 ply per 1000 ft. roll.....	\$5.30
2 ply per 1000 ft. roll.....	7.80
3 ply per 1000 ft. roll.....	9.70
Brownskin, Standard, 500 ft. roll.....	7.00

**BUILDING HARDWARE**—

Sash cord com. No. 7.....	\$2.65 per 100 ft.
Sash cord com. No. 8.....	3.00 per 100 ft.
Sash cord spot No. 7.....	3.65 per 100 ft.
Sash cord spot No. 8.....	4.00 per 100 ft.
Sash weights, cast iron, \$75.00 ton.	
Nails, \$3.42 base.	

**CONCRETE AGGREGATES**—

The following prices net to Contractors unless otherwise shown. Carload lots only.

	Bunker per ton	Del'd per ton
Gravel, all sizes .....	\$2.44	\$2.75
Top Sand .....	2.38	3.13
Concrete Mix .....	2.38	3.06
Crushed Rock, ¼" to ¾".....	2.38	2.94

	Bunker per ton	Del'd per ton
Crushed Rock, ¾" to 1½".....	\$2.38	\$3.13
Roofing Gravel .....	2.81	3.50
River Sand .....	2.50	3.06

**Sand**—

Lapis (Nos. 2 & 4).....	3.56	3.94
Olympia (Nos. 1 & 2).....	3.56	3.88

**Cement**—

Common (all brands, paper sacks), carload lots, \$3.02 per bbl. f.o.b. car; delivered \$3.40. Cash discount on carload lots, 10c a bbl., 10th Prox., less than carload lots \$4.00 per bbl. f.o.b. warehouse or delivered. Cash discount 2% on L.C.L.

Atlas White	} 1 to 100 sacks, \$3.13 sack warehouse or del.; \$9.56 bbl. carload lots.
Calaveras White	
Medusa White	

**DAMP-PROOFING and Waterproofing**—

Two-coat work, \$5.00 per square.  
 Membrane waterproofing—4 layers of saturated felt, \$9.00 per square.  
 Hot coating work, \$3.00 per square.  
 Medusa Waterproofing, \$3.50 per lb. San Francisco Warehouse.  
 Tricocel waterproofing.  
 (See representative.)

**ELECTRIC WIRING**—\$15 to \$20 per outlet for conduit work (including switches).

Knob and tube average \$6.00 per outlet. (Available only for priority work.)

**ELEVATORS**—

Prices vary according to capacity, speed and type. Consult elevator companies. Average cost of installing a slow speed automatic passenger elevator in small four story apartment building, including entrance doors, about \$8000.00.

**EXCAVATION**—

Sand, \$1.00; clay or shale, \$1.50 per yard. Trucks, \$30 to \$45 per day.  
 Above figures are an average without water. Steam shovel work in large quantities, less; hard material, such as rock, will run considerably more.

**FIRE ESCAPES**—

Ten-foot galvanized iron balcony, with stairs, \$250 installed on new buildings; \$300 on old buildings.

**FLOORS**—

Composition Floors, such as Magnesite, 50c per square foot.  
 Linoflor—2 gages—\$3.00 per sq. yd.  
 Mastipave—\$1.50 per sq. yd.  
 Battleship Linoleum—available to Army and Navy only—1/8"—\$3.50 sq. yd.  
 3/8"—\$3.50 sq. yd.  
 Terazzo Floors—\$1.50 per sq. ft.  
 Terazzo Steps—\$2.50 per lin. ft.  
 Mastic Wear Coat—according to type—20c to 35c.

**Hardwood Flooring**—

Standard Mill grades not available.  
 Victory Oak—T & G  
 3/8 x 2¼".....\$252.00 per M. plus Cartage  
 ½ x 2".....\$210.00  
 ½" x 1½"..... 200.00  
 Prefinished Standard & Better Oak Flooring  
 3/8 x 3¼".....\$265.00 per M. plus Cartage  
 ½ x 2½"..... 237.00 per M. plus Cartage  
 Maple Flooring  
 3/8" T & G Clear \$330.00 per M. plus Ctg.  
 2nd 305.00 per M. plus Ctg.  
 3rd 255.00 per M. plus Ctg.  
 Floor Layers' Wage, \$2.12½ per hr. (Legal as of July 1, 1947. Given us by Inlaid Floor Co.)

**GLASS**—

Single Strength Window Glass.....	\$.40 per □ ft.
Double Strength Window Glass.....	.60 per □ ft.
Plate Glass, under 75 sq. ft.....	1.25 per □ ft.
Polished Wire Plate Glass.....	2.10 per □ ft.
Rgh. Wire Glass .....	.60 per □ ft.
Obscure Glass .....	.40 per □ ft.
Glazing of above is additional.	
Glass Blocks.....	\$.275 per □ ft. set in place

**HEATING**—

Average, \$2.50 to \$3.00 per sq. ft. of radiation, according to conditions.  
 Warm air (gravity) average \$64 per register.  
 Forced air average \$91 per register.

**INSULATION AND WALLBOARD—**

Insulation—Full thickness	\$65.00 per M sq. ft.
Insulation—Full thickness	\$95.50 per M sq. ft.
Insulation—Foil-mounted	
Both sides	\$33.50 per M sq. ft.
One side—4'x6' panel	\$9.00 per panel
Wallboard—1" thickness	\$49.50 per M sq. ft.
Gypsum Plank	\$69.00 per M sq. ft.
Gypsum Tileboard	\$69.00 per M sq. ft.

**IRON**—Cost of ornamental iron, cast iron, etc., depends on designs.

**LUMBER—**

No. 1 Common	\$90.00 per M
No. 2 Common	88.00 per M
Select O. P. Common	94.00 per M

**Flooring—**

V.G., D.F. B & Btr. 1 x 4 T & G Flooring	\$170.00
"C" and better—all	170.00
"D" and better—all	170.00

Rwd. Rustic—"A" grade, medium dry	150.00
8 to 24 ft.	
"B" grade, medium dry	150.00

Plywood	15c to 18c per ft.
Plyscord	9½c per ft.
Plywall	9c per ft.
Plyform	15c per ft.

**Shingles (Rwd. not available)—**

Red Cedar No. 1—\$13.00 per square; No. 2, \$10.50; No. 3, \$9.00.  
 Average cost to lay shingles, \$6.00 per square.  
 Cedar Shakes—Tapered: ½" to ¾" x 25"—\$17.00 per square.  
 Resawn: ¾" to 1¼" x 25"—\$22.00 per square  
 Average cost to lay shakes,— 8.00 per square

**MILLWORK—Standard.**

D. F. \$150 per 1000. R. W. Rustic \$175 per 1000 (delivered).  
 Double hung box window frames, average with trim, \$12.50 and up, each.  
 Complete door unit, \$15 to \$25.  
 Screen doors, \$6.00 to \$8.00 each.  
 Patent screen windows, \$1.25 a sq. ft.  
 Cases for kitchen pantries seven ft. high, per lineal ft., \$12.00 each.  
 Dining room cases, \$15.00 per lineal foot.  
 Rough and finish about \$1.00 per sq. ft.  
 Labor—Rough carpentry, warehouse heavy framing (average), \$60.00 per M.  
 For smaller work average, \$60.00 to \$75.00 per 1000.

**MARBLE—(See Dealers)**

**PAINTING—**

Two-coat work ..... per yard 60c  
 Three-coat work ..... per yard 80c  
 Cold water painting ..... per yard 25c  
 Whitewashing ..... per yard 15c  
 Turpentine... \$1.85 per gal. in 5-gal. cont.  
 Raw Linseed Oil..... \$3.33 per gal. in 5-gal. cont.

Boiled Linseed Oil ..... \$3.23 per gal. in drums.  
 Boiled Linseed Oil—\$3.33 per gal. in 5-gal. containers.  
 Replacement Oil—\$2.75 per gal. in drums.  
 \$2.75 per gal. in 5-gal. containers.  
 Use Replacement Oil..... \$3.00 per gal. in 1 gal. cont.  
 A deposit of \$7.50 required on all drums.

**PATENT CHIMNEYS—**

6-inch	\$2.00 lineal foot
8-inch	2.50 lineal foot
10-inch	3.50 lineal foot
12-inch	4.50 lineal foot

**PLASTER—**

Neat wall, per ton delivered in S. F. in paper bags, \$17.60.

**PLASTERING (Interior)—**

3 Coats, metal lath and plaster	Yard \$3.00
Keene cement on metal lath	3.50
Ceilings with ¾ hot roll channels metal lath (lathed only)	3.00
Ceilings with ¾ hot roll channels metal lath plastered	4.50
Single partition ¾ channel lath 1 side (lath only)	3.00
Single partition ¾ channel lath 2 inches thick plastered	8.00
4-inch double partition ¾ channel lath 2 sides (lath only)	5.75
4-inch double partition ¾ channel lath 2 sides plastered	8.75
Thermax single partition; 1" channels; 2¼" overall partition width. Plastered both sides	7.50
Thermax double partition; 1" channels; 4¾" overall partition width. Plastered both sides	11.00
3 Coats over 1" Thermax nailed to one side wood studs or joists	4.50
3 Coats over 1" Thermax suspended to one side wood studs with spring sound isolation clip	5.00

Note—Channel lath controlled by limitation orders.

**PLASTERING (Exterior)—**

2 coats cement finish, brick or concrete wall	Yard \$2.50
3 coats cement finish, No. 18 gauge wire mesh	3.50
Lime—\$4.00 per bbl. at yard.	
Processed LLime—\$4.15 per bbl. at yard.	
Rock or Grip Lath—¾"—30c per sq. yd.	
⅝"—29c per sq. yd.	
Composition Stucco—\$4.00 sq. yard (applied).	

**PLUMBING—**

From \$150.00 per fixture up, according to grade, quality and runs.

**ROOFING—**

"Standard" tar and gravel, 4 ply—\$11.00 per sq. for 30 sqs. or over.  
 Less than 30 sqs. \$14.00 per sq.  
 Tile \$40.00 to \$50.00 per square.  
 Redwood Shingles, \$15.00 per square in place.  
 5/2 # 1-16" Cedar Shingles, 4½" Exposure ..... \$16.50 square

5/8 x 16"—#1 Cedar Shingles, 5" Exposure ..... \$17.00 square  
 4/2 # 1-24" Royal Shingles, 7½" Exposure ..... \$18.25 square  
 Re-coat with Gravel \$5.50 per sq.  
 Asbestos Shingles \$30 to \$60 per sq. laid.  
 1/2 x 25" Resawn Cedar Shakes, 10" Exposure ..... \$18.50  
 3/4 x 25" Resawn Cedar Shakes, 10" Exposure ..... 21.00  
 1 x 25" Resawn Cedar Shakes, 10" Exposure ..... 22.00  
 Above prices are for shakes in place.

**SHEET METAL—**

Windows—Metal, \$2.50 a sq. ft.  
 Fire doors (average), including hardware \$2.80 per sq. ft.

**SKYLIGHTS—(not glazed)**

Copper, \$1.25 sq. ft. (flat).  
 Galvanized iron, 65c sq. ft. (flat).  
 Vented hip skylights 90c sq. ft.

**STEEL—STRUCTURAL—**

\$220 per ton erected, when out of mill.  
 \$270 per ton erected, when out of stock.

**STEEL REINFORCING—**

\$150 to \$170 per ton, in place.

**STORE FRONTS (None available).**

**TILE—**

Ceramic Tile Floors—\$1.50 per sq. ft.  
 Cove Base—\$1.25 per lin. ft.  
 Glazed Tile Wainscot—\$1.50 per sq. ft.  
 Asphalt Tile Floor ⅛" x ⅝"—\$ .40 per sq. ft.  
 Light shades slightly higher.  
 Cork Tile—\$1.00 per sq. ft.  
 Mosaic Floors—See dealers.  
 Lino-Tile—\$1.00 per sq. ft.

**Wall Tile—**

Glazed Terra Cotta Wall Units (single faced) laid in place—approximate prices:  
 2 x 6 x 12.....\$1.25 sq. ft.  
 4 x 6 x 12..... 1.50 sq. ft.  
 2 x 8 x 16..... 1.45 sq. ft.  
 4 x 8 x 16..... 1.75 sq. ft.

**VENETIAN BLINDS—**

75c per square foot and up. Installation extra.

**WINDOWS—STEEL—**

50c per square foot, \$5 for ventilators.

ARCHITECT AND ENGINEER

# IN THE NEWS

## NEW TYPE WALL SWITCH

A new type electric wall switch equipped with a neon light in the handle, which glows with a soft light when overhead lights are out. Reduces dirty walls caused by groping for ordinary switch in dark.

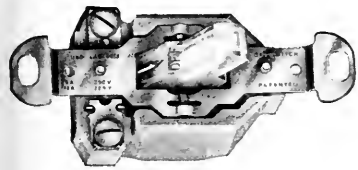

Is single pole type and fits any standard receptacle. Handle is available in variety of colors to fit room colors. Easily renewed and inexpensive. Manufactured by Roberts GLO-SWITCH Division, Brooklyn 8, N. Y.

## LABOR TEMPLE

A CPA permit has been granted for the construction of a new Labor Temple at Oakland, California, to cost \$591,000. Wm. G. Corlett and Arthur W. Anderson, Oakland are the architects.

## PLYWOOD PLANT

The Mutual Plywood Corp'n

will soon start construction of a new \$1,500,000 Plywood Plant at Fairhaven, Humboldt County, California.

## SEWAGE PLANT

\$400,000 in bonds were recently voted by the city of San Carlos, California, for construction of a new sewage disposal plant.

# TOUGH as SHOE - LEATHER - and WATERPROOF, Too!

Specify  
**SISALKRAFT REINFORCED BUILDING PAPER**

FOR CURING AND PROTECTING  
CONCRETE SHEATHING  
AND COVERING MATERIAL

**GUNN CARLE & CO**  
20 POTRERO AVENUE • SAN FRANCISCO, CALIF.

## BUILDING TRADES WAGE (JOB SITES) NORTHERN AND CENTRAL CALIFORNIA

ATTENTION: The following are the PREVAILING hourly rates of compensation as determined by the Wage Adjustment Board, or which have been determined by the United States Department of Labor—Revised to July 1, 1946. Wage scales shown are those being paid and in effect mostly by agreement between employees and their union.

CRAFT	San Francisco	Alameda and Contra Costa	Marin	Vallejo	San Mateo	San Jose	Stockton	Sacramento	Fresno
ASBESTOS WORKERS.....	1.75	1.75	1.75	1.75	1.75	1.75	1.75	1.75	1.75
BRICKLAYERS.....	2.05	2.05	2.05	2.05	2.05	2.05	1.75	2.05	2.00
BRICKLAYERS, HODCARRIERS.....	1.57½	1.57½	1.57½	1.57½	1.57½	1.57½	1.47½	1.15	1.25
CARPENTERS.....	1.75	1.75	1.75	1.75	1.75	1.62½	1.50	1.50	1.50
CEMENT FINISHERS.....	1.75	1.75	1.75	1.75	1.75	1.75	1.75	1.75	1.75
ELECTRICIANS.....	1.87½	1.87½	1.87½	1.70	1.87½	1.87½	1.75	1.82½	1.75
ENGINEERS: MATERIAL HOIST.....	1.60	1.60	1.60	1.60	1.60	1.60	1.60	1.60	1.60
PILE DRIVER.....	2.00	2.00	2.00	2.00	2.00	2.00	2.00	2.00	2.00
STRUCTURAL STEEL.....	2.00	2.00	2.00	2.00	2.00	2.00	2.00	2.00	2.00
GLASS WORKERS.....	1.58½	1.58½	1.58½	1.58½	1.58½	1.21	1.40	1.37½	1.37½
IRONWORKERS: ORNAMENTAL.....	1.85	1.85	1.85	1.85	1.85	1.85	1.85	1.85	1.85
REINF. RODMEN.....	1.75	1.75	1.75	1.75	1.75	1.75	1.75	1.75	1.75
STRUCTURAL.....	2.00	2.00	2.00	2.00	2.00	2.00	2.00	2.00	2.00
LABORERS: BUILDING & CONCRETE.....	1.25	1.25	1.15	1.15	1.15	1.15	1.25	1.25	1.15
LATHERS.....	1.90	1.90	1.60	1.87½	1.75	2.00	1.87½	1.60	1.87½
MARBLE SETTERS.....	1.75	1.75	1.75	1.75	1.75	1.75	1.75	1.75	1.75
MOSAIC & TERRAZZO.....	1.75	1.75	1.75	1.75	1.75	1.75	1.60	1.16	1.12½
PAINTERS.....	1.75	1.75	1.75	1.64	1.75	1.75	1.60	1.60	1.50
PILEDRIVERS.....	1.86	1.86	1.86	1.86	1.86	1.86	1.86	1.86	1.86
PLASTERERS.....	2.00	2.00	1.75	2.00	2.05	2.00	2.00	1.87½	1.87½
PLASTERERS' HODCARRIERS.....	1.75	1.75	1.75	1.75	1.75	1.75	1.65	1.65	1.40
PLUMBERS.....	1.87½	1.87½	1.87½	1.87½	1.87½	1.87½	1.87½	1.87½	1.87½
ROOFERS.....	1.50	1.62½	1.50	1.62½	1.25	1.37½	1.50	1.50	1.50
SHEET METAL WORKERS.....	1.75	1.75	1.75	1.75	1.75	1.75	1.75	1.75	1.75
SPRINKLER FITTERS.....	1.58	1.58	1.58	1.58	1.58	1.58	1.58	1.58	1.58
STEAMFITTERS.....	1.87½	1.87½	1.87½	1.87½	1.87½	1.87½	1.87½	1.87½	1.87½
STONESETTERS (MASON'S).....	2.05	2.05	2.05	2.05	2.05	2.05	1.75	2.05	2.00
FILESETTERS.....	1.80	1.75	1.75	1.75	1.75	1.75	1.37½	1.37½	1.37½

Prepared and compiled by

CENTRAL CALIFORNIA CHAPTER, ASSOCIATED GENERAL CONTRACTORS OF AMERICA

with the assistance and cooperation of secretaries of General Contractors Associations and Builders Exchanges of Northern California.

# CLASSIFIED ADVERTISING

RATE: 10c PER WORD . . . CASH WITH ORDER

MINIMUM \$2.50

**ARCHITECT'S REPORTS**—A valuable advance news service giving building and construction information daily on projects in Northern California. Name, location, architect, proposed cost, etc., on individual slips. Deal for securing new business leads. Hundreds of items, total monthly cost only \$10. Don't delay, subscribe today. ARCHITECT & ENGINEER, Room 618, 68 Post Street, San Francisco, California. Phone DOuglas 3311.

**PHOTOGRAPHS:** Specializing in building and construction photographs for publication, or historic records. For Industrial-Aerial. Publicity photography use the INDUSTRIAL PHOTO'S, Room 722, Hearst Bldg., San Francisco, Phone SUtter 6953.

**METAL WINDOWS** (Steel-Aluminum-Bronze). Large Stock, ALL TYPES. STEEL SASH SALES & SERVICE, Weehawken, N. J.

**ENGRAVING**—Good engravings are essential to a satisfactory job of printing reproduction. For the best, see Poor Richard Photo Engraving Co., 324 Commercial St., San Francisco.

**CLINTON  
CONSTRUCTION CO.  
OF CALIFORNIA**

**General Contractors**

923 FOLSOM STREET • SAN FRANCISCO  
SUtter 3440

**HOGAN LUMBER CO.**

*Wholesale and Retail*

**LUMBER**

**MILL WORK • SASH & DOORS**

*Office, Mill, Yard and Docks*  
SECOND AND ALICE STREETS • OAKLAND, CALIF.  
Telephone GLencourt 6861

**SISALKRAFT**

REG. U. S. PAT. OFF.

*"More than a building paper"*

**THE SISALKRAFT CO.**

205 West Wacker Drive  
Chicago, Ill.

55 New Montgomery Street  
San Francisco, Calif.

**SANTA MARIA INN  
SANTA MARIA, CALIFORNIA**

FRANK J. McCOY, General Manager  
FERNAND E. PIMENTEL, Manager

On the  
Coast  
Highway  
between  
San  
Francisco  
and  
Los  
Angeles



American  
or  
European  
Plan  
•  
Old  
English  
Tap  
Room

**PORCELAIN ENAMEL ON STEEL**

(From Page 11)

limiting himself to one system of panel attachment.

On work requiring competitive bidding, the usual procedure is for the architect to indicate on his quarter-scale drawings only the design, dimensions, color, and most desirable jointing.

By leaving the details of fabrication of the panels and exact shapes to the manufacturer, the architect is assured that his design will be executed according to plan.

Specifications also usually require that the enameler furnish samples and complete shop drawings showing his suggested attachment and joining method in detail for the architect's approval.

The Carnegie-Illinois Steel Company has published Don Graf Data Sheets for architectural porcelain enamel on steel. They contain valuable information on design, finish, forming and attachment. They are furnished without charge to builders and architects.

Porcelain enamel steel panels have been selected by some prefabricated housing organizations as their basic framing material. This may prove to be the best market for porcelain enamel steel products.

The material also offers interesting possibilities for exterior walls of large, multi-story buildings, since it weighs only a fraction of the tremendous deadweight of conventional outside wall construction.

Lighter outside walls would also mean lighter and less expensive steel framing. And since porcelain enamel panels are quickly and economically installed, labor costs are greatly reduced.

Many city building officials have set up sections in their building codes covering porcelain enameled metal veneers. To standardize the regulations governing the use of these veneers, the Building Officials Conference of America compiled and adopted a veneer code on June 15, 1944.

With more widespread use of the material, it is expected that more communities will adopt the suggested metal veneer code approved by the Conference.

**INDUSTRIAL EXPANSION**

Industrial development throughout the 48 northern California counties through the month of May, represented 420 projects with expenditures amounting to \$57,678,200.

This compares with 649 projects for the same period of last year and a total expenditure of \$53,409,768.

## MULLEN MFG. COMPANY

BANK, STORE AND OFFICE  
FIXTURES—CABINET WORK  
OF GUARANTEED QUALITY  
CHURCH SEATING

Office and Factory:  
40-80 RAUSCH ST., Bet. 7th and 8th Sts.  
San Francisco  
Telephone UNderhill 5815

## THE TORMEY COMPANY

GENERAL PAINTERS  
AND DECORATORS

Phone UNderhill 1913

563 FULTON STREET  
San Francisco

## DINWIDDIE CONSTRUCTION COMPANY

BUILDERS

CROCKER BUILDING  
SAN FRANCISCO



*Fine*  
**ENGRAVINGS**  
**POOR  
RICHARD**  
PHOTO ENGRAVING CO.  
220-324 COMMERCIAL STREET  
SAN FRANCISCO, CALIF.

## IN THE NEWS

### APPALLING LOSS

More than 31,000,000 acres of timber, an area as large as New York State, are burned every year in 200,000 forest fires. One of the consequences of this loss is the doubling of wholesale lumber prices since 1936.

### PACKING HOUSE BUILDING

Zaminovich Bros. Inc., of Orange Cove (California) have awarded a contract to Trehwhitt, Shields & Fisher, general contractors of Fresno, for the construction of a new \$300,000 packing house building.

### RAPIDESIGN

The Architects Aid No. 29 has been expressly designed for the architect, draftsman and building contractor as its cut-outs provide a quick uniform and neat delineation of the most commonly used architectural symbols.

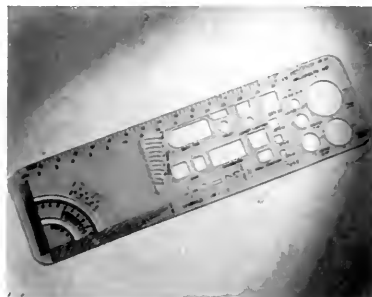

It is made from .030 plastic sheets with printing on negative side to keep it from wearing off. Template is 2 3/4" x 10"; symbols scaled 1/4" to the 1". Available from Charles Baron, Rapidesign, Inc., P. O. Box 592, Glendale, Calif.

### PAROCHIAL SCHOOL

The St. Leo Parochial School, Piedmont, California, have been granted a CPA permit for the construction of classrooms, kindergarten, cafeteria, and remodel the present auditorium and Convent. Wm. E. Schirmer, Architect, estimates the work will cost in the neighborhood of \$335,000.

### BONDS VOTED

The San Luis Obispo Jr. College District (California) have voted \$1,050,000 bonds for new junior college buildings.

### HIGH SCHOOL BUILDINGS

More than \$633,000 will be spent in additions to the Tamalpais Union High School of Mill Valley, California. A F.W.A. grant of \$35,130 has been approved and architects Franklin, Kump & Faulk of San Francisco have been selected.

### ANGLO CALIFORNIA BANK

Architect H. H. Winner, of Ross, California, has completed plans for remodel of the Anglo California National Bank in Oakland, at an estimated cost of \$404,000. CPA permit has been granted.

## Scott Company

HEATING - - PLUMBING - - TILE



243 MINNA STREET  
SAN FRANCISCO  
Phone EXbrook 6741



## HERRICK IRON WORKS

STRUCTURAL STEEL  
REINFORCING STEEL

16TH AND CAMPBELL STS.  
OAKLAND, CALIF.  
Phone GLencourt 1767

Phone GARfield 1164

## Thomas B. Hunter

Consulting Engineer  
DESIGNER OF HEATING  
AIR CONDITIONING  
VENTILATING AND WIRING  
SYSTEMS. MECHANICAL  
AND ELECTRICAL EQUIP-  
MENT OF BUILDINGS

41 SUTTER STREET  
ROOM 710  
San Francisco California

**George F. Brayer**

**ELECTRICAL  
CONTRACTOR**

**166 Seventh Street  
San Francisco**

Phone: Market 1761

**PITTSBURGH  
TESTING LABORATORY**

Successors to  
SMITH, EMERY & COMPANY

*Testing and Inspecting  
Engineers and Chemists*

Structural Materials, Structures  
Equipment, Pipe, Soils.

**651 Howard St., San Francisco 5  
EXbrook 1747**

**A. F. MATTOCK CO.**

*Builders*



**212 CLARA STREET  
SAN FRANCISCO**

**INDEPENDENT  
IRON WORKS**

Steel Buildings  
Service Stations  
Steel Storage Tanks  
Fabricated Plate Work  
Steel & Sheet Metal Products  
Fabricated Structural Steel  
Steel Distributors

**Eighth & Pine Sts. Oakland, 7**

**Index to Advertisers**

ALADDIN Heating Corp.	48
ARCHITECTS Reports	32
ARISS-KNAPP Co.	31
BASALT Rock Company, Inside Back Cover	
BAXTER & Company, J. H.	38
BRAYER, Geo. F.	48
CLASSIFIED Advertising	45
CLINTON Construction Company	46
CROCKER First National Bank	34
DETROIT Steel Products Co.	7
DINWIDDIE Construction Co.	47
d' CHRISTINA & son, J.	30
DOIDGE-KOREN Paint Co.	28
ENTERPRISE Electric	40
FORDERER Cornice Works	32
FREETHY, Elmer J., Gen. Cont.	28
FULLER, W. P., Co.	8
GUNN, Carle & Company	45
HANKS, Inc., Abbot A.	48
HAWS Drinking Faucet Company	5
HERRICK Iron Works	47
HOGAN Lumber Company	46
HUNT, Robert W., Company	48
HUNTER, Thos. B.	47
INDEPENDENT Iron Works	48 & 31
JUDSON, Pacific-Murphy Corp.	32
KRAFTILE Company	1
LEADER Electric Company	30
MATTOCK, A. F.	48
MAZZA, Sam; Painting	28
MICHEL & Pfeffer Iron Works, Inside Back Cover	
MULLEN Mfg. Co.	47
MULLER Brass Co.	2
NORTHERN California Electrical Bureau	37
PACIFIC Coast Aggregates, Inc.	*
PACIFIC Coast Gas Association	*
PACIFIC Electrical & Mechanical Co.	29
PACIFIC Manufacturing Company	42
PACIFIC Portland Cement Company, Inside Front Cover	
PACIFIC Telephone & Telegraph Co.	35
PITTSBURGH Testing Laboratory	48
POOR RICHARD Engraving	47
REED, Geo. W.	28
REMILLARD-Dandini Co.	48
REPUBLIC Steel Corporation	42
ROYAL Showcase	30
SANTA Maria Inn	46
SCOTT Co.	47
SIMONDS Machinery Company	42
SIMPSON Logging Co.	6
SISALKRAFT Company	46
SMOOT-Holman Co.	39
STANLEY Works, The	36
TAYLOR Co., Halsey W.	*
TOLAND, C. E., Company	30
TORMEY Company, The	47
U. S. BONDS	*
VERMONT Marble Company	42
WESTERN Asbestos Company	*
WESIX Company	41
WOOD, E. K., Lumber Company	38

\*Indicates Alternate Months

**ALADDIN  
Heating Corp.**

Specializing in  
**QUALITY HEATING  
EQUIPMENT**

**2222 San Pablo Avenue  
OAKLAND  
TWinoaks 1022**

**ABBOT A. HANKS, INC.  
Engineers & Chemists**

INSPECTING — TESTING — CONSULTING  
CONCRETE • STEEL • MATERIALS  
CHEMICAL AND TESTING  
LABORATORIES  
• RESEARCH AND INVESTIGATION •

TESTS OF STRUCTURAL MATERIALS  
DESIGN OF CONCRETE MIXES  
SHOP AND ERECTION INSPECTION OF  
STRUCTURES AND EQUIPMENT  
INVESTIGATION OF STRUCTURES  
AND MATERIALS  
TESTS AND INVESTIGATION OF  
FOUNDATION SOILS  
FIRE RESISTANCE AND INSULATION  
TESTS

**624 Sacramento Street, San Francisco**

**Robert W. Hunt Company  
ENGINEERS**

Inspection • Tests • Consultation  
Schools and Other Structures  
Are Built as Designed

*When Construction Materials are  
Inspected at point of Manufacture  
and during Erection by*

**ROBERT W. HUNT COMPANY**

*Cement, Concrete, Chemical, Metallurgical,  
X-Ray and Physical Laboratories*

Chicago • New York • Pittsburgh  
Los Angeles • All Large Cities  
**San Francisco, 251 Kearny Street**

**REMILLARD-DANDINI Co.**

**Brick and  
Masonry Products**



**400 MONTGOMERY STREET  
SAN FRANCISCO, CALIF.**

# ARCHITECT AND ENGINEER



AUGUST

1947

# WESTERN MERCHANDISE MART:

NOW... truly the largest building in the world  
faced with Adhesion Type Ceramic Veneer!



Architect: Capitol Company

## Adhesion Type Ceramic Veneer proved to be "self-supporting" on new addition!

● When completed in 1937, the Western Merchandise Mart in San Francisco was the largest building ever faced with Adhesion Type Ceramic Veneer. The following 10 years have confirmed this material as an ideal facing not only for this structure, but also for scores of others, both large and small. Ease of installation... light weight... permanence... beauty... versatility... and economy have made it the preferred *modern* facing material.

The addition to the Western Merchandise Mart is faced with Adhesion Type Ceramic Veneer to match the original building. When the granite base course specified for the first story did not arrive on schedule, the Ceramic Veneer installation was started at the third story with only a small wooden shelf to hold the first course, thus proving that Ceramic Veneer bears its own weight and actually becomes an integral part of the structure. Subsequent courses were applied by adhesion in the usual manner.

Why not investigate Adhesion Type Ceramic Veneer for both new construction and modernization? Gladding McBean & Co.'s engineers are always at your service.

## NEW CATALOG ON PRESS

Contains technical data, photographs of installations, suggested specifications and other useful information on both Adhesion and Anchored Types of Ceramic Veneer.

WRITE FOR YOUR FREE COPY TODAY!

### STANDARD INSTALLATION PROCEDURE:



1. Structural wall is wet; Ceramic Veneer soaked.



2. Mortar is applied to wall and Ceramic Veneer back.



3. Ceramic Veneer is put in place, topped to fill voids.

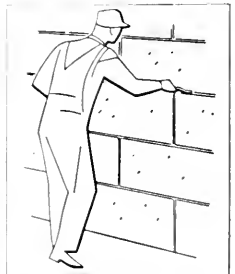

4. Joints are pointed. Surface is washed as last step.

GLADDING  
McBEAN & CO.

*Ceramic Veneer*

THE MODERN MACHINE-PERFECTED TERRA COTTA

OFFICES AT: SAN FRANCISCO • LOS ANGELES • SEATTLE



# • ARCHITECT

Vol. 170 No. 2

# AND ENGINEER

ARCHITECTS' REPORTS—Published Daily  
Telephone DOuglas 2-8311

E. H. WILDER  
Editor

MARK DANIELS, A.I.A.  
Associate Editor

JOHN S. BOLLES, A.I.A.  
Book Reviews

MICHAEL GOODMAN  
Post-War Planning

E. N. KIERULFF\*  
Ass't Editor  
\*In the Service



## Contents for

# AUGUST

COVER PICTURE: New Western Merchandise Mart, San Francisco (See page 20)

### ARTICLES AND MISCELLANEOUS TEXT

EDITORIAL NOTES . . . . .	4
NEWS AND COMMENT ON ART . . . . .	13
NEW SOUTH SAN FRANCISCO W. P. FULLER PLANT . . . . .	15
LANDSCAPE ARCHITECTURE—MICHAEL A. NAIFY, GARDEN, Woodside Eckbo, Royston & Williams, Landscape Architects	16
NEW ADDITION TO THE WESTERN MERCHANDISE MART, San Francisco	20
A. I. A. ACTIVITIES . . . . .	31
WITH THE ENGINEERS . . . . .	32
IN THE NEWS . . . . .	34, 37, 39, 43, 46
HEADLINE NEWS AND VIEWS, By E. H. W. . . . .	36
LANDSCAPE ARCHITECTURE, Notes of the Profession . . . . .	38
ESTIMATOR'S GUIDE, Building and Construction Materials . . . . .	41
BUILDING TRADES WAGE SCALES, Northern and Central California . . . . .	43
CLASSIFIED ADVERTISING . . . . .	43
BOOK REVIEWS, Pamphlets and Catalogues . . . . .	45
INDEX TO ADVERTISING . . . . .	48

ARCHITECT AND ENGINEER (Established 1905) is published on the 15th of the month by The Architect and Engineer, Inc., 68 Post St., San Francisco 4; Telephone EXbrook 2-7182. President, K. P. Kierulff; Vice-President and Manager, L. B. Penhorwood; Treasurer, E. N. Kierulff.

Los Angeles Office: Wentworth F. Green, 6605 Hollywood Blvd., Los Angeles 28. Telephone HEMPstead 3171.

Entered as second class matter, November 2, 1905, at the Post Office in San Francisco, California, under the Act of March 3, 1879. Subscriptions United States and Pan America, \$3.00 a year; \$5.00 two years; foreign countries \$5.00 a year; single copy 50c. ARCHITECTS' REPORTS are published daily from this office, Vernon S. Yallop, Manager.



# EDITORIAL NOTES

## ROUND ONE—lost!

Efforts of the Architectural profession to secure legislative help in solving present policies of the State of California in practicing Architecture in competition with private enterprise ended with tabling of the Bill in Senate Committee.

Architects who presented the professional unity at Sacramento and sponsored legislative action which would merely place the private Architect on an even basis with the State of California in the practice of architecture, are to be commended for their effort.

Legislators are busy "experts," especially in Sacramento during a Legislative Session. The place to really win the Architects battle against the practice of architecture by the State of California, and the unfairness to individual architects, is at the ballot box at home.

Get acquainted with the legislative representative BEFORE he is elected—if he understands the problem then, Round Two may be different.

\* \* \*

## URBAN DEVELOPMENT

Mr. Kenneth C. Black, member of the Board of Directors of the American Institute of Architects, called on the nation's architects recently to help impress the need for urban planning on the American people.

It is Black's belief that "the most potent factor in bringing our cities to their present sad state of physical development has been an uncontrolled speculation in real estate based upon a grid-iron street pattern which was designed primarily to produce a maximum of profit from a minimum of land area."

"Ever increasing numbers of people are awakening to the fact that the urban development program produced by this system has created an artificial mode of life which leaves much to be desired. Consequently more and more people are moving out of this archiac pattern into surrounding areas where they can lead more agreeable personal lives," and in conclusion Black contends;

"We should have a crusade to free our communities from the strait-jackets imposed by faulty street patterns and the unintelligent restrictions in deeds, zoning ordinances, and building codes. American architects should lead the crusade."

While Mr. Black's point may be well taken in some areas of the nation, there is no place in the World where freedom of living has been so well developed as it has on the Pacific Coast. "Archiac patterns" in "strait-jacket" formats, are not a part of West Coast living.

## THE INTERNATIONAL SCENE

"Professions are international as are the arts and sciences they serve; but there are national differences in practice and expression. The Architect worthy of his calling must have a broad knowledge of his profession as it is practiced not only in his own country but also in other lands. International contacts are, therefore, of great importance. Through them the Architect can learn how his colleagues throughout the world are solving their problems, what new methods they are developing, what techniques they are using, what aesthetics are prevailing, as well as the general status of the profession in other countries. Keeping abreast of the times from an international point of view is in fact the study of the contemporary history of the profession.

The average practitioner has neither the time nor the facilities to acquaint himself with even a few foreign countries. He must rely therefore upon his professional society to obtain this material for him and to keep him informed through exhibitions, publications, talks, and conventions.

Almost all countries have professional societies of Architects, anxious to exchange information. The American Institute of Architects communicates with foreign societies through its Committee of Foreign Relations. This Committee keeps the members of the Institute informed of major happenings in the profession abroad, and also informs the foreign societies of the development of architecture in the United States. It reports competitions of importance, organizes the exchange of exhibitions of work, and distributes material of architectural import to professional journals and to the press.

To establish closer ties between the architects of various countries and to facilitate a more direct exchange of views, the International Congress of Architects meets periodically, and, for the professionals of the Western Hemisphere, the Pan-American Congress of Architects meets every four years in one of the American republics. The programs discussed at those congresses deal with many subjects of interest to the profession, and the published reports constitute important documents on the problems and status of the profession in many countries.—Leopold Arnaud, A.I.A. Dean School of Architecture, Columbia University, in "Architecture A Profession and A Career," A.I.A.

\* \* \*

NEW CONSTRUCTION investment has been running about 39 per cent ahead of last year in the United States, with the possibility that the \$17.5-billion year of 1942 will be topped.

# Nothing else quenches thirst like *Cool, Clear Water...*

**T**he refreshing goodness of sparkling clear water...readily available...is one of the blessings of our American way of life. Most everywhere you go in this great country of ours you find modern, sanitary drinking fountains. Many of these fountains were built by HAWS and we are proud of our contribution to this good old American custom.

You'll be proud, too, of the drinking water facilities you plan, when you specify HAWS Drinking Fountains for your clients. HAWS fountains are smart and modern in design, sparkling clean and easy to maintain. HAWS has been a pace-setter in adding new improvements to their fountains and you will always find them tops in mechanical excellence and dependability. ☆ Write today for full information.

# HAWS

## SANITARY DRINKING FOUNTAINS

**HAWS DRINKING FAUCET CO.**  
1808 HARMON STREET (SINCE 1909) BERKELEY 3, CALIFORNIA  
*Agents and Sales Representatives in All Principal Cities*

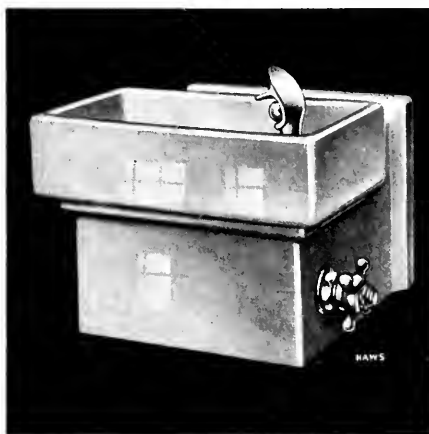

**MODEL 7D—Pacifica**  
Vitreous China Angle Stream Fountain  
with Chrome Trim



**MODEL 8**  
Angle Stream Head with Enameled  
Iron Drinking Fountain Bowl



**Mr. Don A. Proudfoot**

With a broad background of education, training and experience in acoustics, Mr. Proudfoot ranks as one of the country's outstanding acoustical engineers. He is a graduate physicist, having majored in acoustical studies under one of the nation's foremost authorities on architectural acoustics at the University of California at Los Angeles. Mr. Proudfoot has had many years' field experience with acoustical contracting firms. During the war he was selected to serve with Columbia University Division of War Research on underwater sound work in connection with submarine warfare under the auspices of the Office of Scientific Research and Development.

**OUTSTANDING ACOUSTICAL ENGINEER  
HEADS SIMPSON ACOUSTICAL DEPARTMENT**

SIMPSON research has been combined with long experience in the wood products field, new manufacturing processes, new controls for uniformity, and an ultra modern plant to produce an acoustical tile of improved quality, performance and appearance.

In appointing Mr. Don A. Proudfoot to head the Acoustical Department, Simpson is providing their acoustical contractors and their customers with technical and field experience to

match the quality of the products. Mr. Proudfoot is recognized as one of the country's outstanding acoustical engineers. His wide experience in sound research for the government, his knowledge and years of practical experience in architectural acoustics, will provide the highest type of technical service. Mr. Proudfoot's services are available to all Simpson applicators as an aid in providing scientifically correct solutions to problems involving noise quieting and acoustical correction.



**Simpson**  
QUALITY SINCE 1895

**ACOUSTICAL TILE**

—made from the  
long fibers of matchless  
Douglas Fir

**WOOD FIBER DIVISION • SIMPSON LOGGING COMPANY**

Plant at SHELTON, WASHINGTON

Sales Division

SIMPSON INDUSTRIES, 1065 Stuart Building, Seattle 1, Washington

Also Manufacturers of LUMBER • PLYWOOD • DOORS • INSULATING BOARD PRODUCTS

**DISCUSS THIS NEW ACOUSTICAL TILE WITH YOUR NEAREST SIMPSON APPLICATOR**

**ALLIED CONSTRUCTION & SPECIALTY CO., INC.**  
8455 Melrose Ave., Los Angeles 46, Calif. Phone Walnut 0541

**ANGELES INDUSTRIES**  
934 McGarry St., Los Angeles, Calif. Phone: Vandike 1783

**ARIZONA SASH, DOOR & GLASS CO.**  
657 West St. Mary's Road Tucson, Ariz. Phone: 1699

**ROSE CITY FLOOR & INSULATING CO.**  
Railway Exch. Bldg., Portland, Ore. Phone: Atwater 6444

**CONSOLIDATED ROOFING & SUPPLY COMPANY**  
520 South 7th Ave., Phoenix, Ariz. Phone 47888

**CONTINENTAL LUMBER CO.**  
P. O. Box 2042, Boise, Idaho Phone: 450

**ELLIOTT BAY LUMBER CO.**  
600 W Spokane St., Seattle, Wash. Phone: Elliott 8080

**ELLIOTT BAY LUMBER CO.**  
2712 McDougall St., Everett, Wash. Phone: Main 150

**EXCHANGE LUMBER & MFG. CO.**  
P. O. Box 1514, Spokane 7, Wash. Phone: Glenwood 1621

**FROST HARDWOOD LUMBER CO.**  
Market at State St. San Diego, Calif. Phone: F-7224

**UTAH LUMBER CO.**  
333 W. 1st So., Salt Lake City 9, Utah. Phone: 4-4318

**LUMBER DEALERS, INC.**  
1301 Wozee St., Denver 17, Colo. Phone: Tabor 6141

**LUMBER DEALERS, INC.**  
108 South Main St., Pueblo, Colo. Phone: 4881

**LUMBER DEALERS, INC.**  
423 No. 33rd, Billings, Mont. Phone: 3911

*Designed for beauty... standardized for economy*  
**NEW FENCRAFT FAMILY\* OF WINDOWS**

**\*CASEMENT...PROJECTED...COMBINATION**

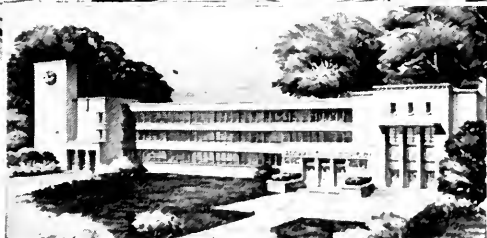
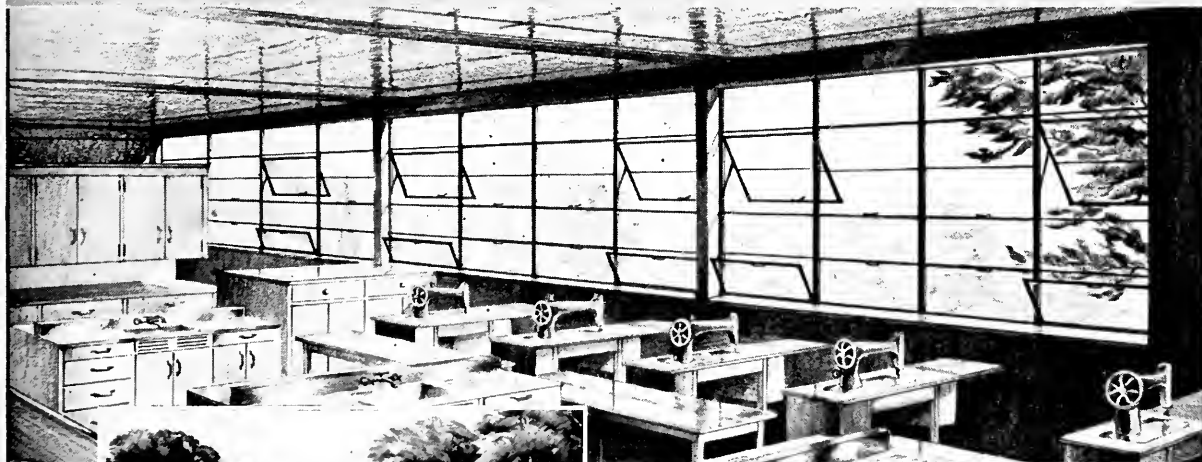

*Suggestion:* To make a domestic science room sparkle with sunlight and good cheer, combine with steel mullions a series of Fencraft Standard Intermediate Projected Windows, such as Type 416 (illustrated).

Three new lines of Fencraft Windows now offer new high quality, lower cost and important installation economy.

Built of specially-designed steel casement sections, by craftsmen in the shops of America's oldest and largest steel window manufacturer, all Fencraft Windows beautify both the outside and the inside. They provide permanently easy operation, firesafety, more daylight, better ventilation, safe cleaning, superior screening, lasting weathertightness and low maintenance cost.

Singular economy in first cost is made possible by standardized manufacture—the concentration of production on standard types and sizes.

Uniform installation details, plus the coordination of window dimensions with those of collateral materials in the wall, minimize installation cost.

Eminently suited for America's finest buildings, Fencraft Windows are now being shipped to many localities. For product details, mail coupon below.

*Fenestra*



**FENCRAFT INTERMEDIATE STEEL WINDOWS**

Detroit Steel Products Company  
Dept. AE-8  
2262 East Grand Blvd.,  
Detroit 11, Michigan

Please send me data on types and sizes of the new Fencraft family of Fenestra Windows:

Name \_\_\_\_\_

Company \_\_\_\_\_

Address \_\_\_\_\_

# BASKETBALL or BAKERY!

## FULLER FLOOR FINISHES TAKE THE TRAFFIC

Yes, big buyers have given Fuller Floor Finishes scientific wear-tests, *in open competition*—and bought Fuller!

Yet, the tests we like best are the daily beat of a million feet in auditoriums, gymnasiums, institutions, schools, industrial plants and public buildings. You'll find that sort of *proof in use* on floors all over the West!

Isn't that the kind of floor preservation service you want to specify to your clients—for new construction, remodeling or maintenance contracts? Call Fuller first!

W. P. Fuller & Co., San Francisco, Los Angeles, Portland. Branches and Dealers throughout the West.



The score will "rough up" some of the fans, but the *play* won't scuff up these floors. Letters from recreation centers attest the enduring quality of Fuller Gymnasium Finish.



Traffic actually buffs Fuller Florcote to a soft sheen, easily and economically maintained. Florcote penetrates deep, hardens surface fibres of wood, leaves little surface film to scuff. Ideal for industrial floors where cleanliness and machine efficiency are mandatory!



Approved by Maple Flooring Manufacturer's Association and the National Oak Flooring Manufacturer's Association. Fuller Gymnasium Finish! Dries to non-glaring, non-skid, rubber-burn-resisting surface. Non-reactive to water and common cleaning alkalis. Goes on easily with lambs wool applicator, mop or brush.





## Ever wish you were Aladdin?

You remember him . . .

He was the lucky fellow who found a magic lamp. It gave him everything he wished for—from diamond-crusted palaces to a sultan's daughter as his bride.

You've probably wished a lot of times for a miracle like this to happen to you. Maybe not for out-of-this-world treasures, but for something that will take care of the things that are bound to come up.

Like medical expenses, or college for the kids. Or maybe just for the nice, safe feeling it gives you to have some extra money put aside for the future.

Though no magic is involved, there is a way to give you this security. The Payroll Savings Plan. Or, if you're not eligible for the Payroll Plan but have a checking account, the new Bond-a-Month Plan.

Either way, it's almost unbelievable how quickly your money accumulates.

Where else can you get such a *safe*, generous return on your money (\$4 for every \$3)? It's so simple—so easy, you hardly miss the money that you're saving.

And don't forget—at the same time, you're *making more!*

Next to a magic lamp, there's no better way than this to make sure your future is secure.

**Save the easy, automatic way . . . with U.S. Savings Bonds**

Contributed by this magazine

in co-operation with the Magazine Publishers of America as a public service.



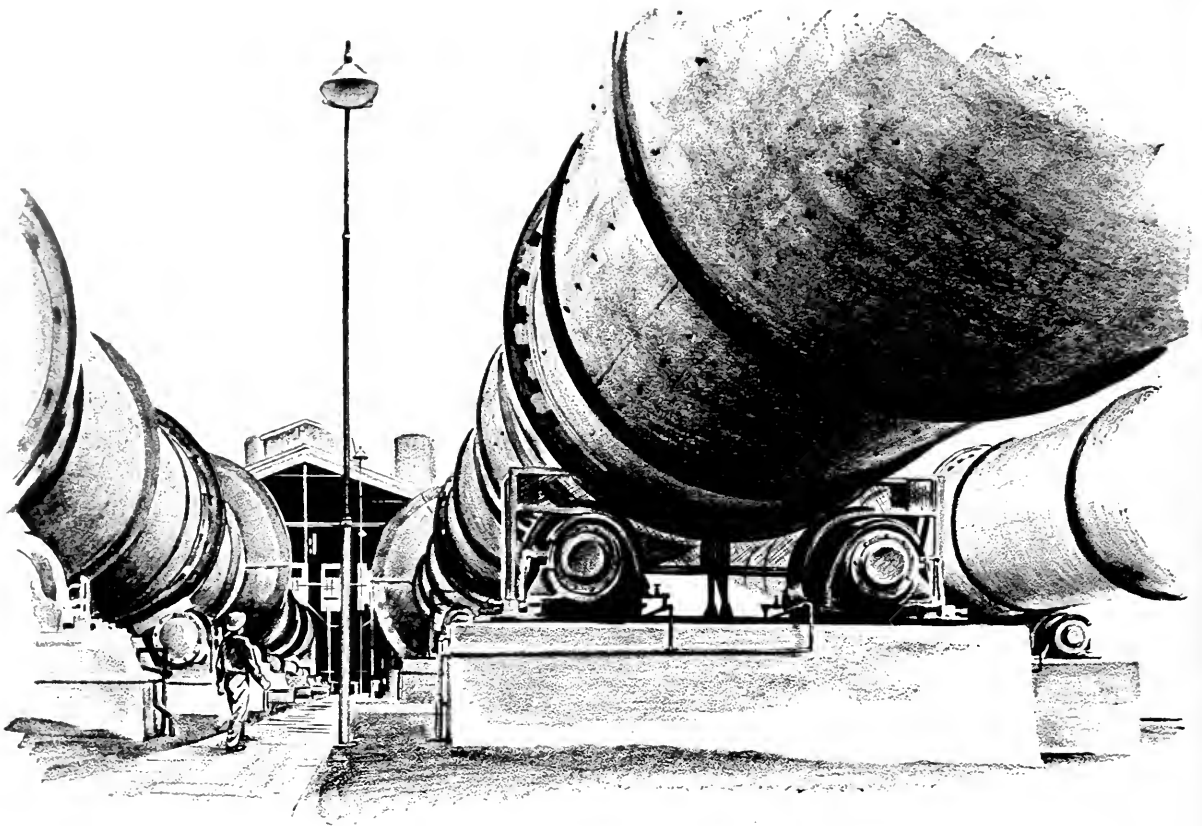

463 foot Rotary Cement Kilns at Permanente.  
The Cement Industry's largest installation.

## *These Great Kilns Helped Build the Merchandise Mart*

14,000 barrels of Yosemite Standard Portland Cement were used by the Ready-Mix Concrete Company, Ltd., of San Francisco for the Western Merchandise Mart addition.

Yosemite Brand Cements are perfectly calcined in huge kilns at Permanente, the world's largest cement plant. This Northern California plant now produces 5,500,000 barrels of cement yearly . . . to meet the demands of Western construction.

Modern laboratory and production practices at Permanente, plus an integrated system of fast loading and distribution, have established new standards of quality and service.

*For all regular or special purposes, order a high quality cement made by Permanente . . . delivered to the job on time.*



*On the job - On time*

PRODUCERS OF PERMANENTE, SANTA CLARA, YOSEMITE AND KAISER BRANDS OF CEMENT AND PERMANENTE LIME PRODUCTS

**PERMANENTE  
CEMENT COMPANY**

OAKLAND • SEATTLE • HONOLULU



# The FINK & SCHINDLER CO.



552 BRANNAN STREET

TELEPHONE EXBROOK 2-1513

## SIXTY-FIFTH ANNIVERSARY



LOCATION OF THE NEW MERCHANDISE MART  
OUR FACTORY LOCATION FROM 1882 UNTIL 1906

ALL CABINET WORK AND MILLWORK  
FOR THE NEW

WESTERN MERCHANDISE MART

BY

## The FINK & SCHINDLER CO.

MANUFACTURERS OF CABINET WORK

COMPLETE INSTALLATIONS OF BAR, STORE, RESTAURANT  
AND OFFICE FIXTURES

SHIP JOINERY • SHIP FURNITURE



C. F. STAUFFACHER . . . President  
GEORGE ZELICK . Secretary-Treasurer  
MODESTO FARINA . Vice President  
C. F. STAUFFACHER, JR. 2nd Vice Pres.

**LABORATORY** walls must withstand corrosive fumes, frequent scrubbing. Kraftile Glazed Wall Units (shown here at the laboratory of the Reconstruction Finance Corporation plant at Riverbank, Calif., operated by Aluminum Company of America) are the ideal answer to the problem.

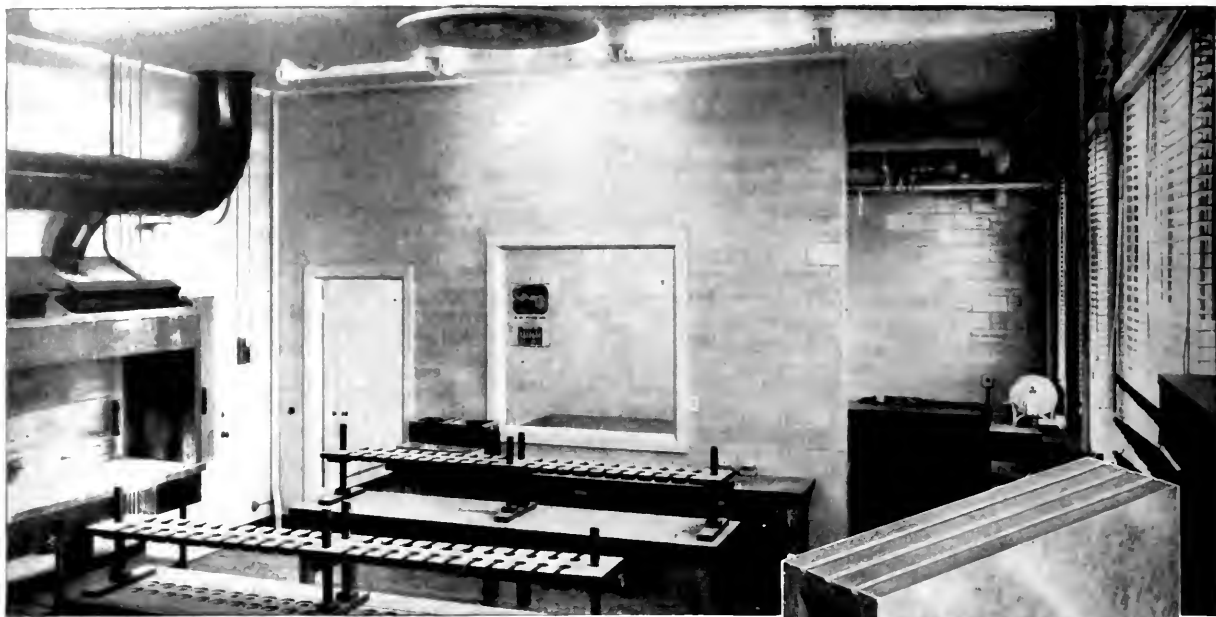

*When you Specify*

## **KRAFTILE** Glazed Wall Units

# for LABORATORY WALLS and PARTITIONS...

*You Get These Important Advantages*

**1. Resistance to moisture and fumes . . .** Glazed surfaces on Kraftile Wall Units defy corrosive fumes, spilled or splattered acids and alkalis.

**2. Non-absorptive surface...** There are no "pores" to absorb odors or destructive fumes or liquids.

**3. Easy cleaning . . .** Walls of Kraftile Glazed Wall Units may be washed down or scrubbed as often as necessary without marring the attractive "lifetime" glazed finish.

**4. High light reflection . . .** Glazed Walls reflect a high percentage of the direct light to provide well-distributed light for the "close" work of reading scales, gauges, etc.

**5. Economy . . .** The finish is "put on at the factory". When the wall is laid up, it's finished! Kraftile Glazed Wall Units are available in 2", 4" or 8" nominal thicknesses, glazed one or both sides. Dimensions are modular coordinated to minimize costly cutting and fitting on the job.

**Data Sheets** on the new modular-dimensioned Kraftile Glazed Structural Wall Units are yours for the asking. Keep them handy . . . they may well be "problem solvers" that can save hours and dollars for you!

**KRAFTILE COMPANY · NILES · CALIFORNIA**

# NEWS AND COMMENT ON ART

## CALIFORNIA PALACE OF THE LEGION OF HONOR

Thomas Carr Howe, Jr., Director, announces the following exhibitions and special events for August.

EXHIBITIONS: Japanese Prints, Opening August 5th; Paintings and Watercolors, by Arnold Friedman, opening August 13th; The Gordon Blanding Collection, opening August 13th; Photographs, by Minor White, opening August 19th; Contemporary British Painting, opening August 10th; Paintings, by Lionel Feininger, through August 17th; the Alma de Bretteville Spreckles Collection of Sculpture by Auguste Rodin; the Mildred Anna Williams Collection of Paintings, Sculpture, Tapestries and Furniture; and the Collis Potter Huntington Memorial Collection of 18th Century French Paintings, Sculpture, Tapestries, Furniture and Porcelain.

EDUCATIONAL ACTIVITIES: Summer projects for Children every Tuesday and Thursday at 10 a.m. and at 2 p.m. There will be no Saturday Classes during August.

ORGAN RECITAL and Concert by Uda Waldrop, each Saturday and Sunday, and Free motion pictures each Saturday at 2:30 p.m.

## CITY OF PARIS ART IN ACTION

An exhibition of Watercolor by Katherine Westphal and Emil White, and Sculpture in Stone and Wood by Blanche Phillips, will be shown in the Rotunda Gallery, City of Paris, starting August 13th and continuing through September 6.

Pictures of the Month by Antonio Sotomayor; Selected pieces of Hollow Ware and Jewelry from the Rotunda July Exhibition; and a special showing of Guatemalan Textiles will be on display from August 10th to 30th in the Art in Action Shop, City of Paris.

## SCULPTURES

by

## HENRY ROX

*M. H. De Young  
Memorial Museum*



## CALIFORNIA SCHOOL OF FINE ARTS

Douglas MacAgy, Director, has announced that registrations for the 18-week Fall term began on August 1st, and that courses for the new school year 1947-48 will commence on August 18th.

Thirty instructors in art training will cover a wide range of subjects including orientation courses in art history and contemporary movements, and instruction to design through the associated arts workshop. In the field of fine art, drawing classes, anatomy, color, painting, sculpture, lithography and etching, and commercial art including advertising layout, lettering, design development, packaging, illustration, textile design, wall decoration, jewelry design, and ceramics. There will also be a course in photography.

In addition to the day classes, the school will offer evening sessions on Mondays, Wednesdays and Fridays.

---

## PLASTICS AS GLAZING MATERIAL

The committee on specifications and methods of the American Standards Association is considering a proposal that requirements for the use of plastic windows in motor vehicles, though not in windshields, be included in the list of standards.

When the association first set its standard for safety glass in 1935 it included requirements for laminated glass, heat-treated glass and wire glass. During the recent war considerable research went into developing plastics that could be used as glazing materials, and the resulting improvements have stimulated renewed interest.

The proposed revision to the standard provides that if plastics are used they must not produce more than a specified amount of distortion to the vision and that temperature changes or cleaning materials must not affect their strength, clarity or freedom from distortion.

Another question up for consideration is the safety of passengers where escape from the vehicle is urgent since their safety may depend on how easily or quickly they can break the window and crawl through the opening.

---

## MODULAR COORDINATION ADVANCED

A \$65,000 grant made to the Modular Service Association by the Office of Technical Services, U. S. Dept. of Commerce, is expected to result in further cutting of construction costs, Tyler S. Rogers, president of the Producers' Council, stated recently.

"The funds will be used to expand and intensify research in methods of coordinating the dimensions of building products in such a way as to

eliminate need for cutting and fitting materials on the building site," Rogers said. "This will make possible important savings in both time and materials."

Modular coordination has been sponsored in recent years by the Producers' Council and the American Institute of Architects. The four-inch module has been adopted as basic by the American Standards Association, and the dimensions of most masonry materials, metal and wooden doors and windows, are being adapted to the module.

Much research remains to be done, however, and the cash grant from the Office of Technical Services will speed up the process, the Producers' Council feels.

"The full extent of possible savings cannot be determined until more materials are made available with coordinated dimensions and until a variety of typical structures have been constructed with such materials," Tyler explained. "The Industry-Engineered Houses being developed jointly by the Producers' Council and the National Retail Lumber Dealers' Association have been designed throughout on the modular basis."

---

## WATER NOT UNLIMITED

River discharge figures for the past 50 years show volumes are from 30 to 75 per cent below those of former years, Ogden S. Jones, chief geologist of the Kansas State Board of Sanitation, speaking told the American Society of Civil Engineers recently in New York.

"Rainfall records show a definite downward trend," Jones declared, "and weather bureau files indicate mean temperatures over the world have shown an upward trend of two or three degrees in the last 20 years, which means accelerated evaporation rates. A sustained temperature increase could easily mean the difference between productive area and a desert. Population increases plus industrial expansion also consumes additional water.

"The cumulative effect of all these factors points to the fact that we are using more water than formerly and are putting less back into the ground," Jones said. "This condition cannot keep up indefinitely," he concluded, "and if steps are not taken to conserve water we may be faced with the necessity of strict control some time in the future."

---

## SEQUOIA HOSPITAL DISTRICT

Architects D. D. Stone and Lou Mulloy, San Francisco, have been selected to design a new 90-bed hospital in San Mateo county, California, the building to cost \$1,000,000.

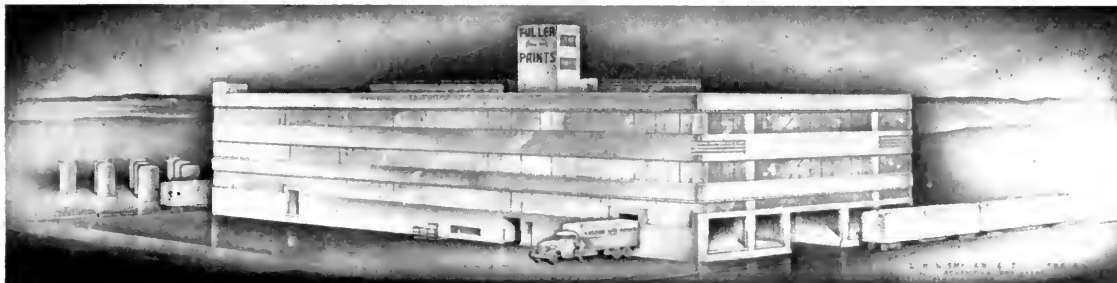

# New South San Francisco W. P. Fuller Co. Plant

Bringing together the specialized industrial departments of two pioneer Western paint companies into a single establishment, by far the largest of its kind on the Pacific Coast, formation of the new Fuller-Nason Industrial Division of the W. P. Fuller & Co. has been completed, according to A. H. Brawner, president.

The new division represents the combined industrial finishes sections of W. P. Fuller & Co., oldest and largest Western paint firm, and R. N. Nason & Co., also a pioneer company and leader in the development of many modern industrial and automotive finishing products and techniques.

The combination brings President D. J. Tight of R. N. Nason & Co. into the Fuller organization as Industrial Advisor. W. W. Holt, for many years a co-worker with Mr. Tight in direction of R. N. Nason & Co., succeeds him as president of that firm.

Outside the industrial finishes field the two companies will continue their independent operations.

Construction of a \$1,000,000 plant designed exclusively for production control and research in the field of specialized industrial finishes has been started at Fuller's South San Francisco factory, following CPA approval.

Pending completion of the new plant, the existing facilities of W. P. Fuller & Co. and R. N. Nason & Co. at San Francisco, South San Francisco, Los Angeles and Portland will be utilized by the new division.

The plant itself, according to General Superintendent George L. Gibson, who supervises Fuller's manufacturing construction programs, will em-

body a number of innovations in the field of production, filling and packaging, as well as in its extensive laboratory facilities.

It will have special conveyor systems, high-speed freight elevators and many other features.

The building will be three stories in height, of reinforced concrete construction, with continuous fenestration.

Design for the building is by Consulting Engineers L. H. Nishkian and B. L. Nishkian. General contractor is the San Francisco firm of Parker, Steffens & Pearce. G. M. Simonson is the electrical engineer.

Heading the production end of the new Fuller-Nason Industrial Division will be W. P. F. Brawner, Director of Production for W. P. Fuller & Co.

The industrial sales staff will operate as part of the General Sales Department of W. P. Fuller & Co. under direction of H. S. Margetts, General Sales Manager. C. E. Ide will be in charge of Fuller accounts, and Gloyd Stankard will have charge of Nason accounts.

Directing the Industrial Research Laboratory will be A. P. Phal, formerly in charge of the Los Angeles laboratory of W. P. Fuller & Co.

Construction of the specialized industrial finishes plant is the largest single item in the \$5,000,000 postwar expansion program of W. P. Fuller & Co., a program which contemplates further industrial construction as well as additions and improvements to the company's warehouses, branch offices and retail stores throughout the West.

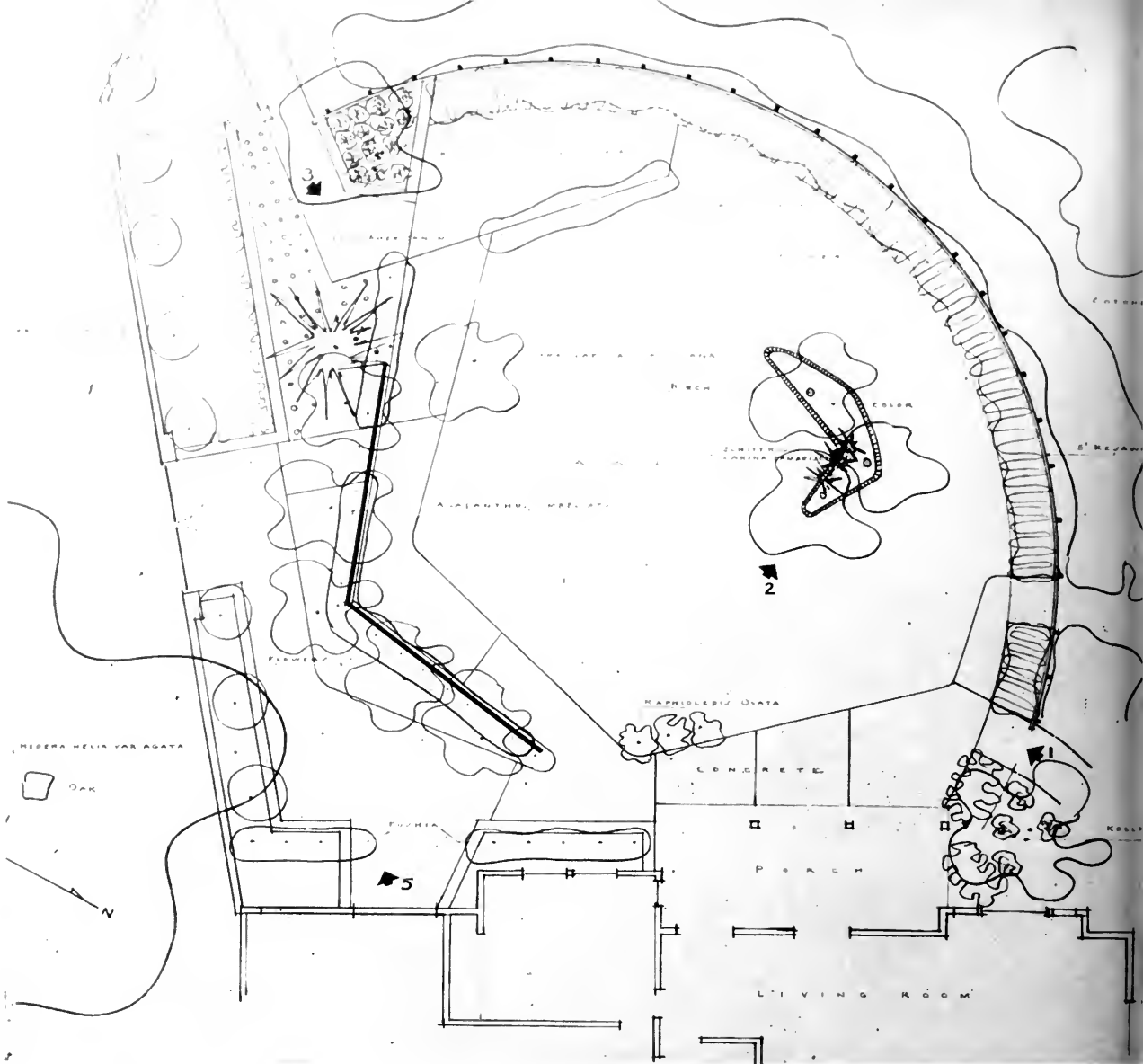

# LANDSCAPE ARCHITECTURE

Michael A. Naify, Garden

Woodside, Calif.

**ECKBO, ROYSTON & WILLIAMS, Landscape Architects**

**Members Association of Landscape Architects**

The plan shows the redevelopment of the entrance garden of a country home in the Woodside hills. This space was formerly used as an automobile turn-around.

In the solution of the problem the entrance circulation is separated from the open garden space by a light screen of pipe verticals with heavy gauge wire horizontals between. Vines are trained upon these wires to further strengthen the function of the screen.

The form of the open space is controlled by the circular fence, the movement of the paving line



1. View looking south into garden

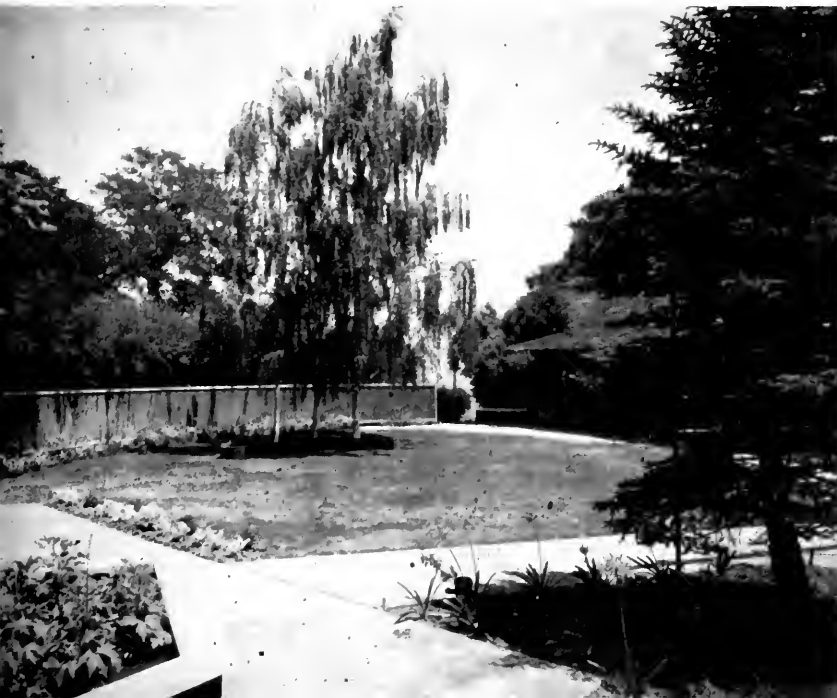

2. View toward the house

**MICHAEL A. NAIFY GARDEN . . .**

- 3. Detail illustration of free form  
planting box around Birch trees.**



- 4. View of the southeast terrace overlooking the valley floor.**





towards the lawn, the raised planting beds, and the planting pattern. The raised beds retain natural grade and were evolved when the entire area was lowered to facilitate drainage away from the house.

The paving is concrete with black integral color and a fine brush finish. The fence is rough sawn redwood stained gray to blend with the treatment of the house. Bordering the screen is a perimeter cap of clear light yellow. The pipe verticals are

deep red with a single gray green cross piece to further emphasize direction. While the predominant color of the plant material is green; blue, red yellow, and gray foliage and flowers were consciously used in an articulate relation of color and form.

The inherent qualities of both machine processed materials and plant materials are emphasized by their interrelated position in the garden composition.

**5. View showing entrance path. The roofed wall is a part of the former garden.**





Dean Stone and Hugo Steccati, Photo

# NEW ADDITION TO THE WESTERN MERCHANDISE MART

— San Francisco

The complete story of the growth and development of the Western Merchandise Mart in San Francisco, is a saga of men and women with typical western pioneer vision of great things to come and

a deep rooted conviction that through personal sacrifice and untiring effort, a great structure could be built on the Pacific Coast which would serve as

(See Page 22)



**DEMOLITION BALL** Wrecking Old Balconade Building (Note action in circle).



**WRECKING** of the four-story building was started on May 28, 1946 and completed on August 3, 1946.

*Moulin, photo*

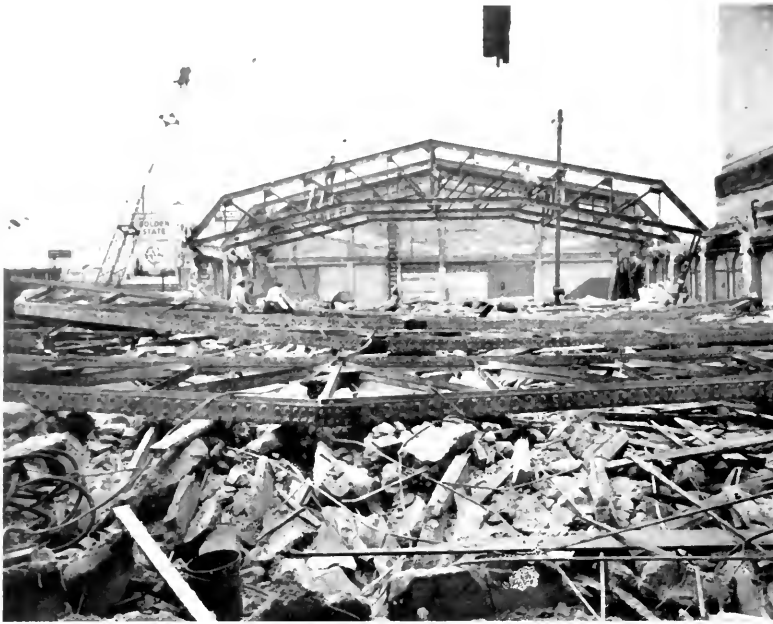

**BALCONADE BUILDING** comes down. Structural steel supporting roof over ballroom being removed by large crane shown at left.

*Moulin. photo*

the keystone of the West's rapidly expanding furniture and furnishings industry.

Founded in 1905 by a small enthusiastic group of supporters, it was the West's first successful effort to establish a centralized home furnishing marketing institution, and since that time it has served the interests of home furnishing retailers, distributors and their sources of supply.

The first building to be occupied by the progressive organization was at 180 New Montgomery

street, and at the time the building was opened the floor space and facilities seemed most adequate. However, within a comparatively brief period of time it became apparent more space would be needed and plans were made for construction of the new Western Furniture Exchange and Merchandise Mart building in the 1300 block on Market street. This new building was completed and opened on July 1, 1937.

It wasn't very long until it again became appar-

**THE NEW ADDITION** begins to take shape as structural steel and reinforced steel concrete forms are set in place.

*Haas & Associates photo*





MARKET STREET AT RIGHT—NINTH STREET AT LEFT

Haas & Associates photo

ent that more space was needed for the display of merchandise and provision was made to demolish a group of buildings adjacent to the Mart which faced on Market street and along Ninth street to Jessie street.

#### WRECKING OLD BUILDINGS

The extensive work of wrecking the old Balconade Building on the corner of Ninth and Market

(See Page 25)

### HEATING AND VENTILATING

#### Merchandise Mart, San Francisco

Installed by

### CORY & JOSLIN, INC.

Mechanical Contracting Engineers

509 Polk Street

San Francisco, Calif.

### WESTERN MERCHANDISE MART

San Francisco, Calif.

The following firms, participants in the construction of the greater WESTERN MERCHANDISE MART, have display advertisements in this issue.

GENERAL CONTRACTOR: Cahill Bros.

HEATING AND VENTILATING: Cory & Joslin, Inc.

SHEET PILE DRIVING: Ben C. Gerwick, Inc.

PLASTERING: Smith & Daneri.

THREADED BRASS WATER LINES: J. Camp & Co.

WRECKING ENGINEERS: Cleveland Wrecking Co.

CAST ALUMINUM WINDOWS: Federal Ornamental Iron & Bronze Co.

CONCRETE: Readymix Concrete Co. Ltd.

UNDERPINNING: D. J. & T. Sullivan.

ELECTRICAL CONTRACTORS: Pacific Electrical & Mechanical Co., Inc.

STRUCTURAL and REINFORCING STEEL: Judson-Pacific, Murphy Co.

ALUMINUM DOUBLE HUNG WINDOWS: Western Asbestos Co.

PHOTOGRAPHS: Haas & Associates

Moulin Studio

Dean Stone & Hugo Steccati

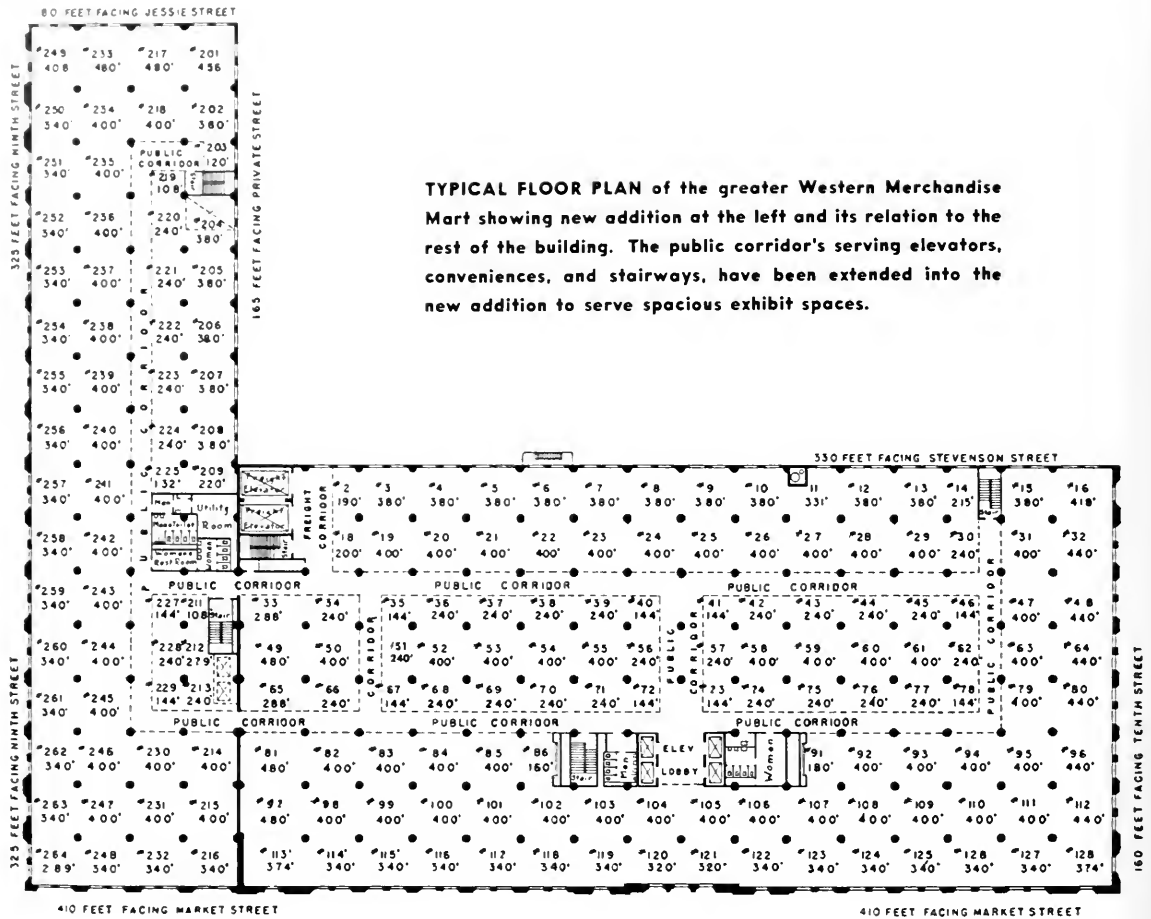

TYPICAL FLOOR PLAN of the greater Western Merchandise Mart showing new addition at the left and its relation to the rest of the building. The public corridor's serving elevators, conveniences, and stairways, have been extended into the new addition to serve spacious exhibit spaces.

**General Contractor**  
 for the  
**Western Merchandise Mart**  
**CAHILL BROTHERS**  
 206 SANSOME STREET SAN FRANCISCO

**SHEET PILE DRIVING**  
 for the  
 Western Merchandise Mart  
 by  
**BEN C. GERWICK, INC.**  
**Engineering Construction**  
 112 Market St., San Francisco Sutter I-7104

Streets, which had housed numerous commercial enterprises and a bank on the ground floor, and the spacious Balconades Ballroom on the second floor, was begun on Tuesday, May 28, 1946.

One of the unusual features of this operation was the use of a specially developed "demolition ball" which had been designed by the wrecking contractor (See illustration at top of page 21) and successfully used in wrecking projects throughout the Bay Area.

The same type of operation had been used by the wrecking company in clearing buildings from the site of the San Francisco Bay Terminal, the Post Office Building in Kansas City, several large theaters in Minneapolis, St. Paul, and Cincinnati; also the Central Viaduct in Cleveland, large bridges in Escanaba, Michigan and several large wrecking projects in Philadelphia.

The process involves the use of a solid metal demolition ball in three sizes—1500 pounds, 3500

pounds, and 4500 pounds. The heavy metal balls are swung from the boom of a large crane, the boom being 100 feet long with a 15-foot jib.

The swinging and dropping action of the demolition ball cuts the wrecking time of the building at least in half over ordinary demolition methods.

**THREADED BRASS HOT AND COLD  
WATER LINES  
INSTALLED THROUGHOUT IN  
WESTERN MERCHANDISE MART**  
by  
**J. CAMP & COMPANY**  
**Plumbing and Heating Contractors**  
Phone MArket 1-5364-5  
1093 Natoma Street San Francisco

**ARCHITECTURAL  
Steel Construction**  
AND  
**Plastering**  
FOR  
*Western  
Merchandise  
Mart*  
BY  
**SMITH & DANERI**  
375 BAYSHORE BLVD.  
SAN FRANCISCO

**WRECKING ENGINEERS  
and LIQUIDATORS**

We specialize in wrecking brick, concrete or steel buildings, bridges, hazards, demolition of all kinds. More than 30 years experience. Bonds furnished—any size.

*We Sell New and Used Building Materials*

"Coast to Coast" . . . . Offices at:

CAMDEN	CINCINNATI	TOLEDO
INDIANAPOLIS	PHILADELPHIA	COVINGTON
CHICAGO	MINNEAPOLIS	ST. PAUL
LOS ANGELES	LOUISVILLE	SAN FRANCISCO

**"If Responsibility Counts — Call on Us"**

  
**CLEVELAND  
WRECKING COMPANY**

2800 Third Street San Francisco 7

Two cranes were used in wrecking the Balconades Building due to the fact that the successful operation of the demolition ball was so fast that it took another clam-shell crane to clean up the debris (See illustration at the bottom of page 21).

The four-story Balconades Building was completely razed and the grounds cleared for the

beginning of construction of the new building on Saturday, August 3, 1946—just 57 days from the start of the wrecking project.

#### NEW BUILDING

The new building is designed to include every modern design and maintains in complete harmony the style of the original building so that the two structures blend into one complete unit as far as general appearances are concerned.

The size of the structure adds eighty feet to the existing 310 feet fronting on Market street making a total of 410 feet and extending from Ninth to Tenth street.

The eighty-foot addition extends 325 feet along Ninth street to Jessie street and then 165 feet along a private driveway to connect with Stevenson street. The combined buildings then extend 330 feet to connect with Tenth street.

**CAST ALUMINUM WINDOWS  
AND STORE ENTRANCES**

*and*

**BRONZE MAIL CHUTE**

*Fabricated and Installed*

*by*

**FEDERAL ORNAMENTAL IRON  
AND BRONZE CO.**

SAN FRANCISCO

MERCHANDISE MART  
**CONCRETE**

*by*

**READYMIX  
CONCRETE CO. LTD.**

• • • Phone HEmlock 1-5733 • • •

**SAN FRANCISCO, 10 CALIFORNIA**



The Public Corridors of the older structure have been extended into the new addition and connect with stairways and modern conveniences which have been provided for the occupants of the building.

From the sheet pile driving to the final installation, the best of materials were used in construction and finishing by the various firms having contracts to do the work.

While numerous uses of modern materials were applied in the building, one of the most interesting, and one which the public can view, is the exterior finish of terra cotta.

**CERAMIC VENEER**

The initial construction of the present Western Merchandise Mart building, to which the new structure has been added, was completed in 1937.

Prior to that time ceramic units had been manufactured and installed by the adhesion method on various buildings, but the Western Merchandise Mart was the first multiple story structure on which

large units were applied solely by the adhesion of cement mortar and as a thin veneer.

Naturally, many architects and engineers questioned the wisdom of using this type material on a ten-story building in view of the earthquake hazard existing in this area. The designers and owners of the building, as well as the manufacturers of the product, however, had full confidence in the efficiency of this method based upon ex-

**UNDERPINNING**  
for the  
**WESTERN MERCHANDISE MART**  
by  
**D. J. & T. SULLIVAN**  
1942 Folsom St., San Francisco      MArket 1-1545

**ELECTRICAL CONTRACTORS**

*FOR THE NEW*

**WESTERN MERCHANDISE MART**

**SAN FRANCISCO—**

INSTALLATIONS BY

**PACIFIC ELECTRICAL AND MECHANICAL CO., INC.**

**16th Street at Vermont  
San Francisco 3  
HEMLOCK 1-5904**

**400 So. Boylston Street  
Los Angeles 13  
MADISON 7641**



**CERAMIC VENEER (TERRA COTTA) ADHESION TYPE:** All plain areas are one-inch thick Ceramic Veneer applied by adhesion of the three-quarter-inch mortar coat. Anchors are used in the heavy ornamented courses only.

tensive tests and the experience which had been gained in the erection of smaller units over a period of several years.

The late L. H. Nishkian, then consulting engineer for this project, conducted an extensive series of stress and strain tests which were viewed by many of the leading architects and engineers of the Bay Area and the West, and as a result of these tests wrote in his report, "The tests demonstrate that Ceramic Veneer, installed by the recommended method develops adhesion and shearing strengths of a least twenty-five times any probable

load which may be expected even in severe earthquake."

During the ten-year period since the Western Merchandise Mart building was erected, many multiple story buildings on the Pacific Coast have been faced with Ceramic Veneer. No evidence of failure at any time, either in these buildings or the various smaller units which have been in place for a much longer period, have appeared.

The illustration at the top of page 28 shows further evidence of the efficiency of the method used

on this addition to the Mart building, as installation was made without interruption due to delayed delivery of certain other construction materials.

Delay in the delivery of the granite base and the metal frames for the first and second stories, made it necessary to start application of the Ceramic Veneer at the third floor level on the typical piers. A one-inch by three-inch wood shelf supported only by a few wood wedges nailed to the concrete were used to keep the first course in place while the mortar set up. (See detailed illustration at lower right on page 29).

Six stories of Ceramic Veneer were applied on top of this initial course with no anchors of any kind, and secured to the wall by adhesion only.

It is pointed out by Gladding, McBean & Co. the manufacturers that this material which has been termed Veneer, or terra cotta, actually becomes an integral part of the structural wall when applied by the adhesion method.

**STRUCTURAL  
AND  
REINFORCING  
STEEL**

**FOR  
Western  
Merchandise  
Mart**

**BY  
JUDSON  
PACIFIC - MURPHY  
CORP.**

**4300 EASTSHORE HIGHWAY  
EMERYVILLE, CALIFORNIA**

**Steel for  
Buildings and Bridges**

**CLOSE-UP OF CIRCLED AREA** shown on opposite page illustration. A 1-inch by 3-inch wood shelf supported only by a few wood wedges nailed to the concrete were used to keep the first course in place while the mortar set-up. Six stories of Ceramic Veneer were applied on top of this course with no anchors.





MODERN DISPLAY AREAS are joined by public corridors which not only serve the new building but also connect with elevators and service facilities of older building.

**FURTHER EXPANSION**

The completion of this newest addition to the Western Merchandise Mart will not conclude the ultimate expansion of the building, as officials of the Mart report that despite the greatly enlarged display space and additional facilities which are provided for by the new Ninth street addition, requests for exhibit space from manufacturers and distributors of furniture and furnishings have already far exceeded the space now available in the combined buildings.

Eventually the Western Merchandise Mart will again expand, and another beautiful addition will be constructed and added to the already nationally recognized "Show Spot" of the West Coast.

**AVAILABLE in 12 STOCK SIZES.**

**ALWINTITE**

**aluminum**

DOUBLE HUNG

**WINDOWS**

4 STYLES



- Superior design & construction
  - Many patented features
- Built-in weatherstripping
  - Easy to handle & install
- Smart trim appearance
  - No painting required
- Screens & stormsash to fit
  - Add visible sales value
- Attractive low prices



SEE US TODAY for FULL INFORMATION

Northern California Distributor

**WESTERN ASBESTOS CO.**

San Francisco • Oakland • Sacramento • Fresno

**"BUILD RIGHT WITH ALWINTITE"**

# A. I. A.

American Institute



# ACTIVITIES

of Architects

- Arizona Chapter:**  
James Macmillan, President; Arthur T. Brown, Secretary, 740 N. Country Club Road, Tucson, Arizona.
- Central Valley of California:**  
Herbert E. Goodpastor, President; Frank V. Mayo, Secretary, 307 Exchange Building, Stockton 2, California.
- Colorado Chapter:**  
Raymond H. Ervin, President; James M. Hunter, Secretary, 2049 Broadway, Boulder, Colorado.
- Montana Chapter:**  
Ralph H. Cushing, President; H. C. Cheever, Secretary, Montana State College, Bozeman, Montana.
- Northern California Chapter:**  
Hervey P. Clark, President; Lester Hurd, Vice-President; Ralph Pollack, Secretary; William C. Ambrose, Treasurer; 605 Market Street, San Francisco.
- Oregon Chapter:**  
Francis Jacobberger, President; J. D. Annand, Secretary, 401 Central Building, Portland 5, Oregon.
- San Diego Chapter (California):**  
H. Louis Bodmer, President; Louis J. Gill, Secretary, 203 Granger Building, San Diego, California.
- Santa Barbara Chapter (California):**  
Roy C. Wilson, President; Miss Lutah M. Riggs, Secretary, 240 Middle Road, Santa Barbara, California.

## CALIFORNIA COUNCIL OF ARCHITECTS

- Vincent Palmer, President; Andrew Hass, Vice-President; A. C. Martin, Jr., Secretary-Treasurer; 369 Pine St., San Francisco 4.
- Southern California Chapter:**  
Adrian Wilson, President; A. C. Martin, Jr., Vice President; Walter L. Reichardt, Secretary; George E. Gable, Treasurer; Chapter Headquarters, 3757 Wilshire Blvd., Los Angeles 5, California.
- Spokane Chapter (Washington):**  
Noel E. Thomson, President; Kenneth D. Storment, Secretary, Hutton Building, Spokane, Washington.
- Utah Chapter:**  
George Cannon Young, President; Theodore R. Pope, Secretary, 29 South State Street, Salt Lake City 1, Utah.
- Washington State Chapter:**  
Clifton J. Brady, President; Arrigo M. Young, Vice-President; John Richards, 2nd Vice-President; Ralf E. Decker, Sec.; Waldo B. Christenson, Treasurer. Office 516 Central Bank Bldg., Seattle 4, Washington.
- Hawaii Chapter:**  
Kenneth W. Roehrig, President; James Morrison, Secretary, 334 Federal Bldg., Honolulu, T. H.

## SOUTHERN CALIFORNIA CHAPTER

"One of the most significant events which has occurred in the Construction Industry is the recent unpublicized conference the Construction Industry members held in Fresno to discuss and bring out the true facts as to the cause of delays in the housing field." declared Council President Adrian Wilson. Subsequent conferences will further clarify the current building situation.

The controversial Los Angeles City Zoning Ordinance will be carefully studied by the Chapter Zoning Committee of which Burnett C. Turner is the Chairman.

The Executive Committee is continuing its efforts to further the use of the Competition Method for the selection of architects for buildings erected by the City and County in the Civic Center Area of Los Angeles.

The Board of Directors of the Southern California Chapter of the Associated General Contractors recently advised its active and specialty members of its desire to eliminate premium payments for overtime and adopt a standard 40-hour work week.

"Unfair competition on the part of plan services, drafting services, lumber companies, designers, complete building services, etc., some of them even offering 'Free architectural services', has become such a large business in this area, and is involving so many citizens, that the time has come that something will have to be done about it if the

State act to regulate the practice of architecture shall remain more than a mere farce." reports Credentials Committee chairman Harold Bissner. Efforts to enact positive legislation to clarify the situation during the recent California Legislature failed in committee.

Charles O. Matcham has been appointed a Member of the Los Angeles Chamber of Commerce, Civic Development Committee.

John I. Landon has been elected President of the Los Feliz Kiwanis Club.

Fred Clark, Press Committee chairman, has been elected to the Board of Directors Los Angeles Cooperative Club.

"ON TO CATALINA—October, 1-2-3-4."

## ARCHITECTS SUPPORT DRIVE

San Francisco architects S. Wayne Hirtzka, Samuel Hyman and Hyman Rosenthal are taking an active part in the Jewish Welfare Fund Campaign, currently being conducted on behalf of the 1,500,000 uprooted Jewish victims of nazi terror in Europe.

**NEW HORTICULTURE BUILDING:** The State of California has allotted some \$2,500,000 for the construction of a new horticultural building on the University of California campus at Davis, California.

# WITH THE ENGINEERS

Structural Engineers Association of Northern California

William W. Moore, President; John A. Blume, Vice President; Franklin P. Ulrich, Treas.; G. A. Sedgwick Sec.; Wm. H. Popert, Consultant; Office, Room 712, 57 Post St., San Francisco, Phone SUtter 5474. DIRECTORS, Mark Falk, M. V. Pregnoff, and R. D. Dewell.

American Society of Civil Engineers San Francisco Section

Theodore P. Dresser, Jr., President; Leon H. Nishikian and Sidney T. Harding, Vice Presidents; John E. Rinne, Secretary-Treasurer; 225 Bush St., San Francisco 20.

Puget Sound Engineering Council (Washington)

R. E. Kister, A. I. E. E., Chairman; E. R. McMillan, A. S. C. E., Vice Chairman; L. B. Cooper, A. S. M. E., Secretary; A. E. Nicherson, I. E. S., Treasurer; Offices, L. B. Cooper, c/o University of Washington, Seattle 5, Washington.

## STRUCTURAL ENGINEERS ASSOCIATION OF NORTHERN CALIFORNIA

John G. Little's special committee report on "Emergencies", John G. Gould's standing committee report on "Consulting Practice," and a report on "Proposed Salaries for Building Inspectors" and "Suggested Fees for Structural Engineering Services," were the principal subjects taken under consideration at a recent meeting.

*Real Estate Loans*



F. H. A. loans are readily available to aid in the purchase of existing homes or in the construction of new ones. You can buy or build a home and pay for it in small monthly installments like rent. For example, a 20-year loan of \$6000 would cost about \$49.56 per month, including real estate taxes, insurance, principal and interest.

**CROCKER FIRST NATIONAL BANK**

SAN FRANCISCO • OAKLAND  
*California's Oldest National Bank*

Member Federal Deposit Insurance Corporation

Copies of the considerations will become available upon approval by the Board of Directors.

A tour of Bay Area steel fabricating shops has been proposed for the near future.

EMPLOYMENT: The business office at room 712 Mechanic's Institute Building, 57 Post Street, is now an employment office for structural engineers.

FRED W. CROCKER is now Chief Engineer of the J. H. Pomeroy & Company, Pittsburg, California.

W. A. GIDDINGS is now connected with Stolte, Inc., Contractors, Oakland.

ANNUAL CONVENTION, October 17-18-19 in Yosemite Valley. Request for reservations should be made at once through office of Consultant, 57 Post Street, San Francisco.

## AMERICAN SOCIETY OF CIVIL ENGINEERS SAN FRANCISCO SECTION

Members heard a technical discussion recently on "The Joint Army-Navy Report on a Second Bay Crossing," by Commodore Lewis N. Moeller, CEC, USN, which advocates a low level southerly crossing of the Bay.

Commodore Moeller's talk was illustrated with charts.

The Excursion Committee recently arranged a visit to the University of California's Cyclotron at Berkeley, and in conjunction with the Junior Forum facilities at the San Francisco Naval Shipyard were also visited.

NEW MEMBERS of the San Francisco Section include: Members, Graham Steel; Associate Members, R. E. Blyberg, D. J. Faustman, and F. W. Jacobs; Juniors, C. W. McCormick, Norman Murdoch, M. H. Slater, and V. A. Smoots.

## RETIRES FROM BS

Simon H. Ingberg, Chief of the Fire Resistance Section of the National Bureau of Standards, has been announced by Dr. E. U. Condon, Director of the Bureau.

An authority on fire protection, his scientific fire severity research has proved to be basic to the problem of fireproof construction.

## RENAMED TRUSTEE N. Y. STATE COLLEGE OF FORESTRY

Charles A. Upson, founder and chairman of the board of directors of the Upson Company, Lockport, New York, was reappointed a trustee of the

New York State College of Forestry for a term of six years.

The paper making school of NYSC of Forestry is nationally recognized.

### INDUSTRIAL RESEARCH

Assistant research director Albert H. Bump, of the Merrimac Division, Monsanto Chemical Company, has been named Senior Industrial Scientist.

This is a new position created by the company for the purpose of pioneering work in the chemical field.

### ALBERT FARR—1871 - 1947

A native of Omaha, Nebraska, he lived in Yokohama, Japan, as a boy and came to California in the 1890's to study architecture. He designed the famous Wolf House for Jack London and built it in The Valley of the Moon. Later he became associated in the firm of Ward & Farr, Architects, San Francisco, California.

### AMERICAN SOCIETY OF CIVIL ENGINEERS MEET

Reports from Duluth, Minn., indicate one of the largest turnouts in the long history of the American Society of Civil Engineers attended the recent three-day annual convention held there.

All sixty-six Sections of the Society were well represented.

A. C. Josephs, President, Duluth Section, opened the meetings which included Board of Directors; annual address by the Society's President; and technical division sessions. In addition to construction, highways, waterways, power and other engineering subjects a pleasing variety of social functions were scheduled.

### MECHANICAL ENGINEERS

The annual Fall Meeting of the American Society of Mechanical Engineers will be held in Salt Lake City on September 1, 2, 3, and 4, while the 68th Annual Meeting has been set for December 1-5 in Atlantic City, N. J.

### CHICAGO LIGHTING ENGINEERS

The Chicago Section of the Illuminating Engineering Society will sponsor an "all-industry" dinner during the 2nd International Lighting Exposition and Conference in Chicago in November.

Cooperating in arrangements are Paul Gerhardt, Jr. Chicago Chapter A.I.A., and H. L. Palmer of the Illinois Society of Architects.

STEEL MILL PRODUCTION for the first half of 1947 established a new peacetime record with a total tonnage of 42,267,320.

# Plan for built-in telephone outlets

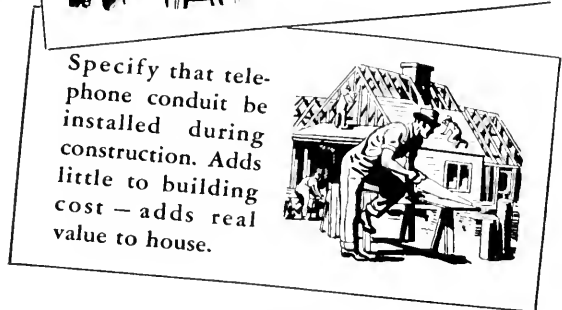
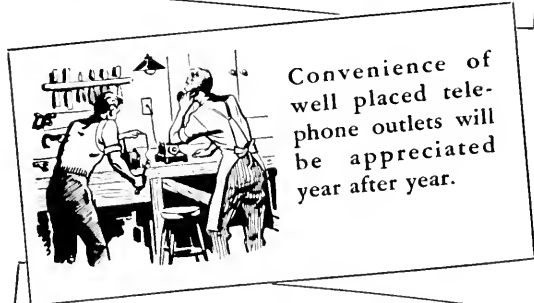
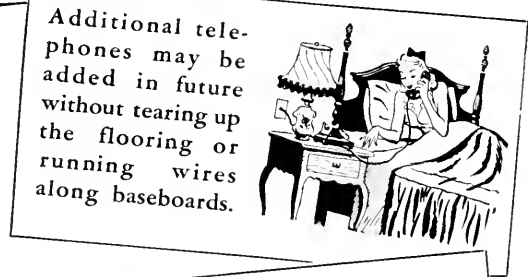
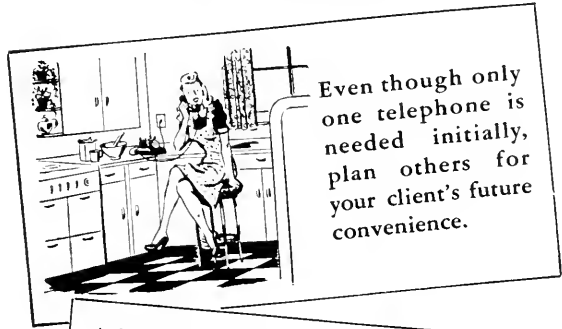

Call your local Telephone Business Office. Ask for free Architects' and Builders' Service.

## The Pacific Telephone and Telegraph Co.



## IN THE NEWS

### LICENSED CONTRACTORS INCREASE IN CALIFORNIA

The California State Contractors License Board reports an all time high in the number of contractors now licensed in California.

The new figure of 45,733 is 6500 greater than the number as of June 30, 1946, and a little more than 6000 over the all time high recorded in 1939-40.

The Board licenses 46 kinds of contractors, with those involved in general building, painting, plumbing, electrical work, and general engineering making up more than 80 per cent of the total.

### THE PRODUCERS' COUNCIL NORTHERN CALIFORNIA CHAPTER

A recent meeting of the Chapter was devoted to a round-table discussion of ways and means of rendering a programmed cooperative service throughout the construction industry, and particularly in regard to making latest supply and manufacturing information available to the Architectural profession.

The subjects of quicker deliveries, accurate and complete catalog information, specifications and

performance of materials, and other timely items were discussed.

Architect Clem Ambrose, A.I.A., San Francisco, presented the views of the architects and expressed "appreciation of the help which the Producers' Council members are to us."

Ernest P. Larson, of the Celotex Corporation, and vice president of the Council was the program chairman.

### POTENTIAL BUSINESS

Gilbert H. Kneiss, district manager, Office of Housing Expediter, estimates there is a great backlog of building in northern California. In addition to some \$75-Million rejected applications for private projects and some \$90-Million in the State program there are unknown \$-Millions that have not reached the action stage yet, due to high building costs, shortage of material, and scarce high-cost labor.

### KRAFTILE ANNOUNCE PRICE REDUCTION

New price schedules announced by Kraftile Company of Niles, California, show a reduction of five per cent in prices on clear glazed wall units in the more popular 2" and 4" thickness.

According to C. W. Kraft, president of the firm, an up to date cost analysis of the firm's manufacturing operations made a readjustment of the price structure advisable to achieve a more equitable distribution of plant burden.

In announcing the new price schedules, Kraft pointed out that the firm retained their prewar prices until early 1946, at which time a 6 per cent raise had to be made. With the new prices the firm's average prices are virtually back to prewar levels.

### CALIFORNIA CIVIL SERVICE EXAMINATIONS

The State Personnel Board have announced the following California civil service examinations:

September 2: Plumber \$230 or prevailing rate; Instructor in Plumbing \$240; Instructor in Sheet Metal Work, \$240; Institutional Plumber, \$230;

September 4: Administrative Assistant, Division of Water Resources, \$475

September 6: Assistant Civil Engineer, \$310; Assistant Hydraulic Engineer, \$310.

Applications should be filed in San Francisco and Los Angeles.

The atmosphere up to 100 miles will be duplicated at the University of California in the first supersonic aerodynamic studies under the actual conditions of extreme altitude.



School authorities and architects know the best way to modernize the drinking water system is to replace with Halsey Taylor Drinking Fountains. Have you our latest literature showing our complete line for schools?

THE HALSEY W. TAYLOR CO., WARREN, O.  
West Coast Plant Redlands, Calif.

**Halsey-Taylor**  
**DRINKING FOUNTAINS**



## ELECTRICAL INSPECTORS HOLD SANTA CRUZ MEET

Speaking in Santa Cruz at the recent meeting of the Northern California Chapter—Southwest Section—of the International Assn. of Electrical Inspectors, Leonard A. Hobbs, vice president and general sales manager of the Smoot-Holman Co. California, emphasized the great strides made in the lighting industry in the last few decades in raising safety standards for the consumer's benefit. He stressed the fact that manufacturers, wholesalers, contractors and



Mr. Leonard A. Hobbs  
Vice President of  
Smoot-Holman Co.

inspectors work together to give the consumer, on whom the industry depends, his full dollars' worth. Tracing the development of artificial lighting, Hobbs pointed out that filament lamps were developed to their peak efficiency by 1940, and for greater light intensities manufacturers turned to the fluorescent light source. Fluorescent lighting, with its more highly technical construction and installation has given rise to new safety problems, some of which the lighting industry has done much to overcome. The necessity for the proper grounding of fixtures, the debate over methods of circuits feeding continuous row mountings of fluorescent fixtures, and the provision of inspection holes in ceiling fixtures, were some of the problems mentioned.

The establishment of certification groups and the excellent work they have done in creating high standards of manufacture and service, were commended by Hobbs. RLM Standards Institute in the industrial lighting fields, and Fleur-O-Lier in the commercial field were especially recognized as having performed outstanding service to the industry.

Many of the problems which still exist in the lighting industry could be solved or greatly simplified, Hobbs said. Conflicting local regulations, or lack of uniform standards tend to increase costs, retard progress and prevent the use of modern equipment in many communities. The excess cost of manufacture caused by the necessity of special construction for a particular locality; and the added costs of installation resulting from outmoded regulations, are added burdens to the consumer and as such are dangerous to the industry.

MORE HOUSES are being built in 1947 by private builders than for 20 years, the National Association of Home Builders recently reported.

MORE HOUSES are being built in 1947 by private builders than for 20 years, the National Association of Home Builders recently reported.

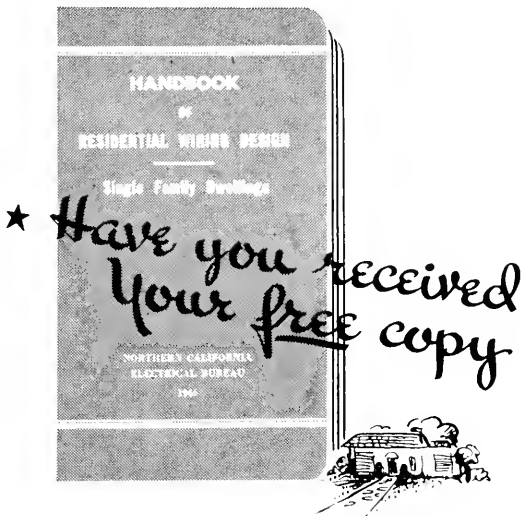

This handbook of residential wiring design for single family dwellings has been prepared especially for the use of architects, engineers, builders, electrical contractors and lending institutions.

It is not a handbook on how to *install* wiring . . . it is one on how to *plan* wiring. It sets forth . . . room by room . . . outlet and circuit requirements for an efficient, convenient and useful home wiring system . . . a system which will help avoid electrical obsolescence.

If you have not received your copy of this free handbook . . . or if you wish additional copies . . . contact your local utility office or this Bureau.



**NORTHERN CALIFORNIA  
ELECTRICAL BUREAU**

1355 MARKET STREET  
SAN FRANCISCO 3



**PRESSURE TREATED LUMBER**  
**● PROTECTS AGAINST DECAY**  
**AND TERMITE ATTACK**

*Specify it in your home*  
*Available through Lumber Dealers*

LOS ANGELES  
 601 W. 5th Street  
 Phone Michigan 6294

SAN FRANCISCO  
 333 Montgomery Street  
 Phone DOuglas 2-3883

**J. H. Baxter & Co.**

AGENTS FOR WEST COAST WOOD PRESERVING CO. SEATTLE, WASH.



**E. K. WOOD LUMBER CO.**  
**LOS ANGELES**

Office and Yards, 4710 South Alameda Street, JE 3111

**OAKLAND**

Yard and Wharves, 2111 Frederick Street

**RETAIL YARDS**

LOS ANGELES • OAKLAND • ONTARIO • HOLLYWOOD • LONG BEACH  
 RIVERSIDE • TEMPLE CITY • SIERRA MADRE • INDI • THERMAL • LA VERNE  
 WHITTIER • UPLAND • PASADENA • SAN PEDRO

**HEADLINE NEWS & VIEWS**

By E. H. W.

Hay! hay! California ranks second only to New York in state revenue derived from horse racing with \$22,778,671 in taxes collected last year.

Los Angeles continues to lead the West in number and amount of building permits topping by nearly 5 times its nearest competitor.

The U. S. Department of Commerce, San Francisco Regional Office has announced it will accept applications of business men for permits to visit Japan. Final approval will be made in Washington.

"The gradual breakdown of the American home is beginning to be reflected in the national behavior pattern and is a real cause for alarm."—J. Edgar Hoover, FBI chief.

The 50th annual meeting of the Illinois Society of Architects was recently held in Chicago. The speaker's subject was "All Old Fools Were Young Fools Once"—don't we ever learn?

"American Bonded Steel Base Metals" is the title of an interesting pamphlet just issued by the American Nickeloid Company of Peru, Ill.

"Under our form of government, control of the purse rests with the legislative branch."—Earl O. Shreve, President U. S. Chamber of Commerce.

The 30th session of the International Labor Conference, Geneva, Switzerland, was attended by J. D. Zellerbach of San Francisco, who represented the U. S. employer in the tripartite conference of government, employer, and labor.

About \$10-billion has been added to the book value of business inventories since the middle of 1946.—U. S. Chamber of Commerce.

Building material prices cannot be reduced while other prices are on stilts—One of the most logical places to start "reducing" is TAXES.

Edgar E. Lampton, director of motor vehicles, State of California, has announced motorists will be furnished with small "tabs" next year in lieu of metal license plates—wonder what all the money collected for licenses is really spent for?

## IN THE NEWS

### LITHOGRAPHING PLANT

A Carlisle Co., San Francisco, have been granted a CPA permit for construction of a new plant estimated to cost \$590,000.

### SCHOOL BONDS VOTED

Santa Cruz, California, recently voted \$1,500,000 in bonds for improvements to the High School and Grammar School buildings.

### ELECTRIC MOTOR FACTORY

CPA permit has been granted General Electric Company for construction of a \$1,700,000 electric motor factory in San Jose, California. Leland S. Rosener, Structural Engineer, San Francisco.

### GYMNASIUM

A CPA permit has been granted the Union High School District of Caruthers (California) for construction of a \$55,000 gymnasium building.

### BANK BUILDING

A permit has been granted by CPA for the construction of a new \$82,400 bank building at Chowchilla, California.

### LIVESTOCK EXHIBIT BUILDING

A \$361,088 livestock exhibit building will be added to the San Francisco "Cow Palace" to serve California Agricultural District No. 1-A.

### BONDS VOTED

The Weaverville Elementary School District (California) have approved issuance of bonds for the construction of a new 5-classroom and kindergarten grammar school building. J. Clarence Felciano, Architect, Santa Rosa.

### COUNTY JAIL ADDITION

L. G. Shalz, Chico, California, has been awarded the general contract for construction of an addition to the Butte county jail at Oroville, to cost \$154,000. E. Geoffrey Bangs, Architect, San Francisco.

### HOSPITAL ADDITION

A general contract has been awarded L. G. Shalz, Chico, California for the addition of a power plant, laundry, kitchen, and dining room to the Butte county hospital at Oroville.

# INSURE A BRIGHT FUTURE!

## Order Smoot-Holman Lighting Equipment Today!

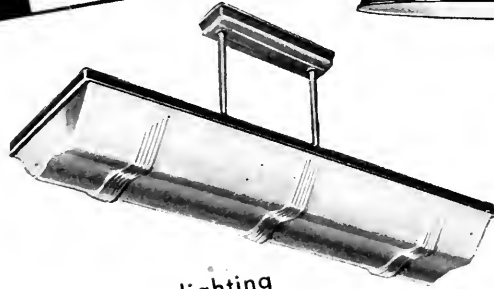

• Buy quality lighting equipment now — while sufficient quantities are available at favorable prices. Continued increases in labor costs and uncertainties in raw material deliveries are darkening shadows which may affect the whole lighting industry. You can brighten your own future by placing your order now for modern, efficient lighting equipment.



Offices in Principal Western Cities — Branch and Warehouse in San Francisco

# LANDSCAPE ARCHITECTURE

## Notes of The Profession

---

ASSOCIATION OF LANDSCAPE ARCHITECTS, SAN FRANCISCO REGION, Vernon Dean, President; Robert Royston, Vice-President; Ned Rucker, Treasurer; E. L. Anderson, Corresponding Secretary, 1736 Franklin, Oakland, California.

---

### HONORS GIVEN PROF. JOHN W. GREGG

The entire Pacific Coast was represented at a testimonial banquet given recently at the Claremont Hotel, Berkeley, in honor of Professor John W. Gregg, who retired at the end of the Spring term as Professor of the Division of Landscape Design of the College of Agriculture, University of California at Berkeley.

Members of the Association of Landscape Architects of northern California, the American Society of Landscape Architects, the Alumni and Students of the Division, and a large number of friends joined in the event.

Professor Gregg came to California from the East to establish the Division of Landscape Design and then served as head of the Division for more than 34 years.

During his work with the University, Professor Gregg was also very active in stimulating public interest in the Landscape profession and took an active part in the American Society of Landscape Architects and formation of the northern California chapter of the Association of Landscape Architects.

Examples of the application of his teachings are the University of California grounds, the Mills College campus, and the U. S. Navy base at Mare Island.

Among those attending the banquet were Ned S. Rucker, vice president Association of Landscape Architects (Toastmaster); Mrs. Ned S. Rucker; Claude B. Hutchinson, Dean of the College of Agriculture and Vice President of the University of California, and Mrs. Hutchinson; Helen Van Pelt, Director at Large, Association of Landscape Architects; L. Deming Tilton, City Planner; Thomas D. Church, Director at Large, Association of Landscape Architects and Art Commissioner of San Francisco; Willa Cloys Carmack, Association of Landscape Architects; H. W. Shepherd, Professor of Landscape Design, University of California, and Mrs. Shepherd; E. O. Essig, Chairman of the Department of Entomology, University of California, and Mrs. Essig; Mr. and Mrs. Sumner Parker of Amherst, Massachusetts; C. F. Elwood, Professor

of Agricultural Extension, University of California, and Mrs. Elwood; Bernard Wiseltier, President Association of Landscape Architects; Mrs. John Gregg, Jr.; James Cobbledick, President, Oakland Business Men's Garden Club, Honorary Member Association of Landscape Architects, and Mrs. Cobbledick; Marion F. Page, Secretary, Division of Landscape Design, University of California; William R. Gant, President, Students Landscape Design Club, University of California; and H. L. Vaughan, Associate Professor of Landscape Design, University of California.

---

### SAN FRANCISCO REGION

Professor H. L. Vaughan has been named to succeed Professor John W. Gregg, retired, as Chairman of the Division of Landscape Design at the University of California. Prof. Vaughan served as President of the A.L.A. for two years and is a member of the board of directors.

\* \* \*

New officers installed for the ensuing year included: Vernon Dean, President; Robert Royston, Vice-president; Kenneth Jones, Recording Secretary; Ned Tucker, Treasurer and E. L. Anderson, Corresponding Secretary. Bernard Wiseltier, immediate past president becomes a member of the Executive Board.

\* \* \*

ACTIVITIES OF MEMBERS: Lynn M. F. Harris of Marin County has been named assistant superintendent of parks for the City of Oakland. He will work under Superintendent William Penn Mott, Jr., on the new Master Plan for the Oakland Park Department. HARRY W. SHEPHERD, Landscape Architect, is collaborating with architects STEIHL, MARROW, AND SMITH, on the site plan for the Armine Products plant-office, International Chemical and Mineral Corporation in San Jose.

JOHN T. BOUCHER, San Carlos, is designing the new \$10,000 Rose Garden at 23rd Avenue, San Mateo. KATY and PAUL STEINMETZ opened their new office in San Rafael. WILLIAM B. SEABURY, Landscape Architect, announces the opening of office in the Thayer Bldg., Oakland.

## NEW HEART OF LOS ANGELES

A proposed plan to modernize the downtown area of Los Angeles, done by senior students of the University of Southern California, College of Architecture, has been made into a 12-foot square model and put on display in the State Exposition Building, Exposition Park.

Director of the project, Dean Arthur H. Gallion, points out that it is a long-time proposal covering a period of years and does not contemplate immediate destruction of large areas.

The model shows location of freeways, civic center buildings, bus terminals and helicopter landing, parking facilities, and grouped industrial locations.

## NEW YORK CONFERENCE

William H. Popert, San Francisco District Engineer, American Institute of Steel Construction, Inc., attended a three day conference of District Engineers of the Institute in New York City recently.

## GOVERNMENT VS. PRIVATE BUILDING

The record of home construction since the end of the war points up convincing evidence that private builders can do a better building job than the government, according to data furnished by the National Association of Home Builders.

The association says that private builders completed 450,000 dwelling units in 1946 despite material shortages and a restrictive government housing program that prevented builders from reaching maximum production. Government, on the other hand, was able to complete only 83,000 temporary barrack-dwellings with \$450 million appropriated for the work.

## AIA CONVENTION SPEAKER

Among speakers at the recent A. I. A. Annual Convention in Grand Rapids, Michigan, was Ernest J. Kump of San Francisco who spoke on the subject "What Does the Architect Give His Public?"

## NATIONAL HOUSING

Applications for new construction during June numbered 48,755, which according to Federal Housing Administration officials, represents the largest volume of units in any single month. The previous high of 43,246 units was established in March 1942.

The figure was more than five times the volume received in June a year ago.

In addition to the new construction, there were 13,544 existing residential units covered by June applications. This brought the total applications in June to 62,299.

## ENGINEER OPENS OFFICE

Neil P. Richards, Structural Engineer, has announced the opening of offices at 408 Professional Building, 1052 West Sixth Street, Los Angeles, California.

He will feature the designing of commercial buildings, bridges, and industrial buildings.

## BASILONE HOMES GO AHEAD

Plans for erection on 908 units at Basilone Homes in the San Fernando Valley are proceeding under a "supplemental application" between the State of California and the City Housing Authority of Los Angeles.

Five hundred and ninety-two units are already completed and occupied.

## INSTRUMENT CONFERENCE

The Second National Instrument Conference, sponsored by the Instrument Society of America, will be held in Chicago on September 8-12.

## HONORED

"For his contribution to better housing for California; and for his staunch adherence to democratic ideals and principles in all phases of the never-ending fight for housing and slum-clearance," the Rt. Rev. Monsignor Thomas J. O'Dwyer, Archdiocese Director of Catholic Charities, recently received the Annual Award for Outstanding Achievement of the Southern California Chapter of the National Association of Housing Officials.

## NEW DISTRIBUTOR

The Midwest Ferro-Therm Distributors, Inc., of Chicago, Ill., have been appointed midwest and central states distributors for the Ferro-Therm Steel Insulation products.

Wm. J. Donahoe is president of the new organization.

## PACIFIC TEL & TEL

The Pacific Telephone & Telegraph Company has awarded the general contract for the construction of their new \$560,000 exchange addition in Fresno, Calif., to Fisher & McNulty of Fresno. Harry A. Thomsen of San Francisco is the architect.

N. H. Sjoberg & Son of Oakland will be the contractors on another P T & T project in Oakland, Calif. This is also a telephone exchange addition and will cost \$420,000. Thomsen & Wilson, San Francisco, are the architects.

## STRUCTURAL STEEL

For Class A Buildings,  
Bridges, etc.

**JUDSON PACIFIC - MURPHY CORP.**

4300 EASTSHORE HIGHWAY  
EMERYVILLE, CALIF.

## FORDERER CORNICE WORKS

*Manufacturers of*

Hollow Metal Products • Interior Metal Trim  
Elevator Fronts and Cabs  
Metal Plaster Accessories • Sanitary Metal Base  
Flat and Roll Metal Screens  
Metal Cabinets • Commercial Refrigerators

**269 POTRERO AVE.**

**SAN FRANCISCO, CALIF.**

**HEMLOCK 4100**

## VALUABLE NEWS SERVICE

- BUILDING MATERIAL DEALERS
- CONTRACTORS
- ENGINEERS
- FINANCIAL INSTITUTIONS

**ARCHITECTS REPORTS** gives advance news on construction projects in Northern California, lists: name of projects, location, architect, proposed cost and other pertinent information.

**HANDY** individual slip-reports, issued daily at a total cost of only

\$10 a month

## ARCHITECT'S REPORTS

Published Daily

The ARCHITECT and ENGINEER, Inc.

68 Post Street, San Francisco - DO 8311

### CONSTRUCTION RISE

New construction totaling \$5.4-billion in the first half of 1947 put this year 40.1 per cent ahead of last year, reports the U. S. Department of Commerce.

The construction pace varied from a drop of 43 per cent in commercial building to a gain of 130 per cent for water and sewer systems.

For the month of June a total of \$1.1-billion showed a ratio of 75 per cent private construction to 25 per cent public. Repair costs were not included in the figures.

### PRACTICAL IDEA

A Building Materials Installation School has been established by the building materials division of the Armstrong Cork Company at Lancaster, Pa., for the training of salesmen and the development of trained installation mechanics.

### FURTHER INTEGRATION

The huge, fully-integrated steel plant at Geneva, Utah, built by the government during the war and sold to the United States Steel Company, will become part of the Columbia Steel Company's set-up, according to an announcement by Benjamin Fairless, U. S. Steel president, during a recent Western trip.

When this consolidation of operations takes place, Columbia Steel, which now operates plants at Pittsburgh and Torrance, California, will become one of the nation's largest steel producers in its own right.

LOS ANGELES continues to lead the Pacific Coast in volume of business building permits.

### APPAREL CITY CONTRACTORS

In an article on San Francisco's Apparel City appearing in the June, 1947 issue of ARCHITECT & ENGINEER credit was given to the firm of Haas and Rothschild as the general contractor. Attention has been called to the fact that this firm is the general contractor for Buildings 1A, 1B, and 2 of the project and that the firm of Barrett & Hilp of San Francisco is general contractor for the remaining buildings, including the Cluett-Peabody Building, a sketch of which was shown on page 22.

Barrett & Hilp and Haas and Rothschild have collaborated as general contractors on the project in complete harmony and in the finest spirit of co-operation and mutual assistance.

# ESTIMATOR'S GUIDE

## BUILDING AND CONSTRUCTION MATERIALS

PRICES GIVEN ARE FIGURING PRICES AND ARE MADE UP FROM AVERAGE QUOTATIONS FURNISHED BY MATERIAL HOUSES TO SAN FRANCISCO CONTRACTORS. 2½% SALES TAX ON ALL MATERIALS BUT NOT LABOR

All prices and wages quoted are for San Francisco and the Bay District. There may be slight fluctuation of prices in the interior and southern part of the state. Freight cartage, at least, must be added in figuring country work.

**BONDS**—Performance—\$10 per \$1000 of contract. Labor and materials, \$10 per \$1000 of contract.

**BRICKWORK**—

Common Brick—Per 1M laid—\$80.00 to \$100.00 (according to class of work).  
 Face Brick—Per 1M laid—\$150 to \$200 (according to class of work).  
 Brick Steps—\$2.30 per lin. ft.  
 Brick Veneer on Frame Bldg.—Approx. \$1.50 per sq. ft.  
 Common Brick—\$26.00 per M, truckload lots, f.o.b. job.  
 Face Brick—\$60 to \$100 per M, truckload lots, delivered.  
 Cartage—Approx. \$5.00 per M.

**BUILDING PAPER**—

1 ply per 1000 ft. roll..... \$5.30  
 2 ply per 1000 ft. roll..... 7.80  
 3 ply per 1000 ft. roll..... 9.70  
 Brownskin, Standard, 500 ft. roll..... 7.00

**BUILDING HARDWARE**—

Sash cord com. No. 7..... \$2.65 per 100 ft.  
 Sash cord com. No. 8..... 3.00 per 100 ft.  
 Sash cord spot No. 7..... 3.65 per 100 ft.  
 Sash cord spot No. 8..... 4.00 per 100 ft.  
 Sash weights, cast iron, \$75.00 ton.  
 Nails, \$3.42 base.

**CONCRETE AGGREGATES**—

The following prices net to Contractors unless otherwise shown. Carload lots only.

	Bunker per ton	Del'd per ton
Gravel, all sizes .....	\$2.44	\$2.75
Top Sand .....	2.38	3.13
Concrete Mix .....	2.38	3.06
Crushed Rock, ¼" to ¾".....	2.38	2.94

	Bunker per ton	Del'd per ton
Crushed Rock, ¾" to 1½".....	\$2.38	\$3.13
Roofing Gravel .....	2.81	3.50
River Sand .....	2.50	3.06

**Sand**—  
 Lapis (Nos. 2 & 4)..... 3.56 3.94  
 Olympia (Nos. 1 & 2)..... 3.56 3.88

**Cement**—  
 Common (all brands, paper sacks), carload lots, \$3.02 per bbl. f.o.b. car; delivered \$3.40.  
 Cash discount on carload lots, 10c a bbl., 10th Prox., less than carload lots \$4.00 per bbl. f.o.b. warehouse or delivered.  
 Cash discount 2% on L.C.L.

Atlas White } 1 to 100 sacks, \$3.13 sack  
 Calaveras White } warehouse or del.; \$9.56  
 Medusa White } bbl. carload lots.

**DAMP-PROOFING and Waterproofing**—

Two-coat work, \$5.00 per square.  
 Membrane waterproofing—4 layers of saturated felt, \$9.00 per square.  
 Hot coating work, \$3.00 per square.  
 Medusa Waterproofing, \$3.50 per lb. San Francisco Warehouse.  
 Tricocel waterproofing.  
 (See representative.)

**ELECTRIC WIRING**—\$15 to \$20 per outlet for conduit work (including switches).

Knob and tube average \$6.00 per outlet. (Available only for priority work.)

**ELEVATORS**—

Prices vary according to capacity, speed and type. Consult elevator companies. Average cost of installing a slow speed automatic passenger elevator in small four story apartment building, including entrance doors, about \$8000.00.

**EXCAVATION**—

Sand, \$1.00; clay or shale, \$1.50 per yard. Trucks, \$30 to \$45 per day.  
 Above figures are an average without water. Steam shovel work in large quantities, less; hard material, such as rock, will run considerably more.

**FIRE ESCAPES**—

Ten-foot galvanized iron balcony, with stairs, \$250 installed on new buildings; \$300 on old buildings.

**FLOORS**—

Composition Floors, such as Magnesite, 50c per square foot.  
 Linoflor—2 gages—\$3.00 per sq. yd.  
 Mastipave—\$1.50 per sq. yd.  
 Battleship Linoleum—available to Army and Navy only—1/8"—\$3.50 sq. yd.  
 3/16"—\$3.50 sq. yd.  
 Terazzo Floors—\$1.50 per sq. ft.  
 Terazzo Steps—\$2.50 per lin. ft.  
 Mastic Wear Coat—according to type—20c to 35c.

**Hardwood Flooring**—

Standard Mill grades not available.  
 Victory Oak— T & G  
 3/4" x 2 1/4"..... \$252.00 per M. plus Cartage  
 1/2" x 2"..... \$210.00  
 1/2" x 1 1/2"..... 200.00  
 Prefinished Standard & Better Oak Flooring  
 3/4" x 3 1/4"..... \$265.00 per M. plus Cartage  
 1/2" x 2 1/2"..... 237.00 per M. plus Cartage  
 Maple Flooring  
 3/4" T & G Clear \$330.00 per M. plus Ctg.  
 2nd 305.00 per M. plus Ctg.  
 3rd 255.00 per M. plus Ctg.  
 Floor Layers' Wage, \$2.12½ per hr. (Legal as of July 1, 1947. Given us by Inlaid Floor Co.)

**GLASS**—

Single Strength Window Glass..... \$ .40 per □ ft.  
 Double Strength Window Glass..... .60 per □ ft.  
 Plate Glass, under 75 sq. ft..... 1.25 per □ ft.  
 Polished Wire Plate Glass..... 2.10 per □ ft.  
 Rgh. Wire Glass .....

**HEATING**—

Average, \$2.50 to \$3.00 per sq. ft. of radiation, according to conditions.  
 Warm air (gravity) average \$64 per register.  
 Forced air average \$91 per register.

**INSULATION AND WALLBOARD—**

Insulation—Full thickness	\$65.00 per M sq. ft.
Insulation—Full thickness	\$95.50 per M sq. ft.
Insulation—Foil-mounted	\$33.50 per M sq. ft.
board—4'x6' panel	\$9.00 per panel
Wall board—1/2" thickness	\$49.50 per M sq. ft.
Finished Plank	\$69.00 per M sq. ft.
Ceiling Triebord	\$69.00 per M sq. ft.

**IRON**—Cost of ornamental iron, cast iron, etc., depends on designs.

**LUMBER—**

No. 1 Common	\$90.00 per M
No. 2 Common	88.00 per M
Select O. P. Common	94.00 per M

**Flooring—** Per M Delvd.

V.G.-D.F. B & Btr, 1 x 4 T & G Flooring	\$170.00
"C" and better—all	170.00
"D" and better—all	170.00

**Rwd. Rustic—"A" grade, medium dry**..... 150.00  
8 to 24 ft.

**"B" grade, medium dry**..... 150.00

**Plywood** ..... 15c to 18c per ft.

**Plyscord** ..... 9 1/2c per ft.

**Plywall** ..... 9c per ft.

**Plyform** ..... 15c per ft.

**Shingles (Rwd. not available)—**

Red Cedar No. 1—\$13.00 per square; No. 2, \$10.50; No. 3, \$9.00.

Average cost to lay shingles, \$6.00 per square.

Cedar Shakes—Tapered: 1/2" to 3/4" x 25"—\$17.00 per square.

Resawn: 3/4" to 1 1/4" x 25"—\$22.00 per square

Average cost to lay shakes,— 8.00 per square

**MILLWORK—Standard.**

D. F. \$150 per 1000. R. W. Rustic \$175 per 1000 (delivered).

Double hung box window frames, average with trim, \$12.50 and up, each.

Complete door unit, \$15 to \$25.

Screen doors, \$6.00 to \$8.00 each.

Patent screen windows, \$1.25 a sq. ft.

Cases for kitchen pantries seven ft. high, per lineal ft., \$12.00 each.

Dining room cases, \$15.00 per lineal foot. Rough and finish about \$1.00 per sq. ft.

Labor—Rough carpentry, warehouse heavy framing (average), \$60.00 per M.

For smaller work average, \$60.00 to \$75.00 per 1000.

**MARBLE—(See Dealers)**

**PAINTING—**

Two-coat work .....per yard 60c

Three-coat work .....per yard 80c

Cold water painting .....per yard 25c

Whitewashing .....per yard 15c

Turpentine.....\$1.85 per gal. in 5-gal. cont.

Raw Linseed Oil.....\$3.33 per gal. in 5-gal. cont.

Boiled Linseed Oil ..... \$3.23 per gal. in drums.

Boiled Linseed Oil—\$3.33 per gal. in 5-gal. containers.

Replacement Oil—\$2.75 per gal. in drums. \$2.75 per gal. in 5-gal. containers.

Use Replacement Oil.....\$3.00 per gal. in 1 gal. cont.

A deposit of \$7.50 required on all drums.

**PATENT CHIMNEYS—**

6-inch	\$2.00 lineal foot
8-inch	2.50 lineal foot
10-inch	3.50 lineal foot
12-inch	4.50 lineal foot

**PLASTER—**

Neat wall, per ton delivered in S. F. in paper bags, \$17.60.

**PLASTERING (Interior)—**

3 Coats, metal lath and plaster	Yard \$3.00
Keene cement on metal lath	3.50
Ceilings with 3/4 hot roll channels metal lath (lathed only)	3.00
Seilings with 3/4 hot roll channels metal lath plastered	4.50
Single partition 3/4 channel lath 1 side (lath only)	3.00
Single partition 3/4 channel lath 2 inches thick plastered	8.00
4-inch double partition 3/4 channel lath 2 sides (lath only)	5.75
4-inch double partition 3/4 channel lath 2 sides plastered	8.75
Thermax single partition; 1" channels; 2 1/4" overall partition width. Plastered both sides	7.50
Thermax double partition; 1" channels; 4 3/4" overall partition width. Plastered both sides	11.00
3 Coats over 1" Thermax nailed to one side wood studs or joists	4.50
3 Coats over 1" Thermax suspended to one side wood studs with spring sound isolation clip	5.00

Note—Channel lath controlled by limitation orders.

**PLASTERING (Exterior)—**

2 coats cement finish, brick or concrete wall	Yard \$2.50
3 coats cement finish, No. 18 gauge wire mesh	3.50
Lime—\$4.00 per bbl. at yard.	
Processed L.L.Lime—\$4.15 per bbl. at yard.	
Rock or Grip Lath—3/8"—30c per sq. yd.	
1/4"—29c per sq. yd.	

Composition Stucco—\$4.00 sq. yard (applied).

**PLUMBING—**

From \$150.00 per fixture up, according to grade, quality and runs.

**ROOFING—**

"Standard" tar and gravel, 4 ply—\$11.00 per sq. for 30 sqs. or over.

Less than 30 sqs. \$14.00 per sq.

Tile \$40.00 to \$50.00 per square.

Redwood Shingles, \$15.00 per square in place.

5/2 # 1-16" Cedar Shingles, 4 1/2" Exposure .....\$16.50 square

5/8 x 16"—#1 Cedar Shingles, 5" Exposure .....\$17.00 square

4/2 # 1-24" Royal Shingles, 7 1/2" Exposure .....\$18.25 square

Re-coat with Gravel \$5.50 per sq.

Asbestos Shingles \$30 to \$60 per sq. laid.

1/2 x 25" Resawn Cedar Shakes, 10" Exposure .....\$18.50

3/4 x 25" Resawn Cedar Shakes, 10" Exposure ..... 21.00

1 x 25" Resawn Cedar Shakes, 10" Exposure ..... 22.00

Above prices are for shakes in place.

**SHEET METAL—**

Windows—Metal, \$2.50 a sq. ft.

Fire doors (average), including hardware \$2.80 per sq. ft.

**SKYLIGHTS—(not glazed)**

Copper, \$1.25 sq. ft. (flat).

Galvanized iron, 65c sq. ft. (flat).

Vented hip skylights 90c sq. ft.

**STEEL—STRUCTURAL—**

\$220 per ton erected, when out of mill.

\$270 per ton erected, when out of stock.

**STEEL REINFORCING—**

\$150 to \$170 per ton, in place.

**STORE FRONTS (None available).**

**TILE—**

Ceramic Tile Floors—\$1.50 per sq. ft.

Cove Base—\$1.25 per lin. ft.

Glazed Tile Wainscot—\$1.50 per sq. ft.

Asphalt Tile Floor 1/8" x 3/4"—\$ .40 per sq. ft. Light shades slightly higher.

Cork Tile—\$1.00 per sq. ft.

Mosaic Floors—See dealers.

Lino-Tile—\$1.00 per sq. ft.

**Wall Tile—**

Glazed Terra Cotta Wall Units (single faced) laid in place—approximate prices:

2 x 6 x 12	\$1.25 sq. ft.
4 x 6 x 12	1.50 sq. ft.
2 x 8 x 16	1.45 sq. ft.
4 x 8 x 16	1.75 sq. ft.

**VENETIAN BLINDS—**

75c per square foot and up. Installation extra.

**WINDOWS—STEEL—**

50c per square foot, \$5 for ventilators.

ARCHITECT AND ENGINEER



# IN THE NEWS

## APPOINTED SALES MANAGER

D. B. Karskind has been appointed Pacific Sales Manager of the U. S. Rubber Company's Wire and Cable Department, with headquarters in San Francisco.

## WORK STARTED

The Standard Oil Company have started work on their new \$5,000,000 grease manufacturing plant and packaging warehouse at Richmond, Calif.

## NAMED PURCHASING AGENT

H. N. Leuckel has been named purchasing agent of the Nelson Electric Corporation, Santa Monica, California, according to A. L. Nelson, President. He was formerly Chief Purchasing agent for Air Communications, Inc., of Kansas City.

## NEW TYPE HYDRAULIC DOOR CLOSER

This entirely new BAKEWELL HYDRO-HINGE door closer which is built like a hinge, eliminates all visible door-closing mechanism. The spring and hydraulic units are completely concealed within specially designed butt hinges, installed same as conventional butts.

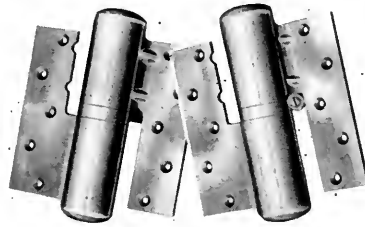

Adjustable for varying speeds, positive latching or silent closing. Tamper proof, non-leakable, sizes and finishes for residential, commercial and industrial uses. Manufactured by Bakewell Products, Los Angeles.

## APARTMENT BUILDING

Elmer H. Osburn has been awarded contract for the construction of an 8-apartment and store building in Gustine, California, at an estimated cost of \$50,000.

## FULL TIME BUSINESS

A. McF. McSweeney, Architect, has resigned as Architectural Instructor at Healds College, San Francisco, to devote full time to the private practice of architecture. He has been an instructor at the College for the past 1 1/2 years.

## DEPARTMENT STORE

Wurdeman & Beckett, Architects, Los Angeles, are taking bids on a \$300,000 improvement to the Brock's Department Store building in Bakersfield, California.

## POLICE & COURT HOUSE

Bonds have been voted for a \$60,000 improvement to the old City Hall, San Mateo, California. Will H. Toepke, Architect.

## BUILDING TRADES WAGE (JOB SITES) NORTHERN AND CENTRAL CALIFORNIA

ATTENTION: The following are the PREVAILING hourly rates of compensation as determined by the Wage Adjustment Board, or which have been determined by the United States Department of Labor—Revised to July 1, 1946. Wage scales shown are those being paid and in effect mostly by agreement between employees and their union.

CRAFT	San Francisco	Alameda and Contra Costa	Marin	Vallejo	San Mateo	San Jose	Stockton	Sacramento	Fresno
ASBESTOS WORKERS	1.75	1.75	1.75	1.75	1.75	1.75	1.75	1.75	1.75
BRICKLAYERS	2.05	2.05	2.05	2.05	2.05	2.05	2.05	2.05	2.00
BRICKLAYERS, HODCARRIERS	1.57 1/2	1.57 1/2	1.57 1/2	1.57 1/2	1.57 1/2	1.57 1/2	1.47 1/2	1.15	1.25
CARPENTERS	1.75	1.75	1.75	1.75	1.75	1.75	1.62 1/2	1.50	1.50
CEMENT FINISHERS	1.75	1.75	1.75	1.75	1.75	1.75	1.75	1.75	1.75
ELECTRICIANS	1.87 1/2	1.87 1/2	1.87 1/2	1.70	1.87 1/2	1.87 1/2	1.75	1.82 1/2	1.75
ENGINEERS: MATERIAL HOIST	1.60	1.60	1.60	1.60	1.60	1.60	1.60	1.60	1.60
PILE DRIVER	2.00	2.00	2.00	2.00	2.00	2.00	2.00	2.00	2.00
STRUCTURAL STEEL	2.00	2.00	2.00	2.00	2.00	2.00	2.00	2.00	2.00
GLASS WORKERS	1.58 1/2	1.58 1/2	1.58 1/2	1.58 1/2	1.58 1/2	1.21	1.40	1.37 1/2	1.37 1/2
IRONWORKERS: ORNAMENTAL	1.85	1.85	1.85	1.85	1.85	1.85	1.85	1.85	1.85
REINF. RODMEN	1.75	1.75	1.75	1.75	1.75	1.75	1.75	1.75	1.75
STRUCTURAL	2.00	2.00	2.00	2.00	2.00	2.00	2.00	2.00	2.00
LABORERS: BUILDING & CONCRETE	1.25	1.25	1.15	1.15	1.15	1.15	1.25	1.25	1.15
LATHERS	1.90	1.90	1.60	1.87 1/2	1.75	1.75	1.75	1.75	1.75
MARBLE SETTERS	1.75	1.75	1.75	1.75	1.75	1.75	1.60	1.16	1.12 1/2
MOSAIC & TERRAZZO	1.75	1.75	1.75	1.75	1.75	1.75	1.60	1.60	1.50
*PAINTERS	1.75	1.75	1.75	1.64	1.75	1.75	1.60	1.60	1.86
PILEDRIVERS	1.86	1.86	1.86	1.86	1.86	1.86	1.86	1.86	1.86
PLASTERERS	2.00	2.00	1.75	2.00	2.05	2.00	2.00	1.87 1/2	1.87 1/2
PLASTERERS' HODCARRIERS	1.75	1.75	1.75	1.75	1.75	1.75	1.65	1.65	1.40
PLUMBERS	1.87 1/2	1.87 1/2	1.87 1/2	1.87 1/2	1.87 1/2	1.87 1/2	1.87 1/2	1.87 1/2	1.87 1/2
ROOFERS	1.50	1.62 1/2	1.50	1.62 1/2	1.25	1.37 1/2	1.50	1.50	1.50
SHEET METAL WORKERS	1.75	1.75	1.75	1.75	1.75	1.75	1.75	1.75	1.75
SPRINKLER FITTERS	1.58	1.58	1.58	1.58	1.58	1.58	1.58	1.58	1.58
STEAMFITTERS	1.87 1/2	1.87 1/2	1.87 1/2	1.87 1/2	1.87 1/2	1.87 1/2	1.87 1/2	1.87 1/2	1.87 1/2
STONESETTERS (MASON'S)	2.05	2.05	2.05	2.05	2.05	2.05	1.75	2.05	2.00
TILESETTERS	1.80	1.75	1.75	1.75	1.75	1.75	1.37 1/2	1.37 1/2	1.37 1/2

Prepared and compiled by

CENTRAL CALIFORNIA CHAPTER, ASSOCIATED GENERAL CONTRACTORS OF AMERICA

with the assistance and cooperation of secretaries of General Contractors Associations and Builders Exchanges of Northern California.

# CLASSIFIED ADVERTISING

RATE: 10c PER WORD . . . CASH WITH ORDER

MINIMUM \$2.50

**ARCHITECT'S REPORTS**—A valuable advance news service giving building and construction information daily on projects in Northern California. Name, location, architect, proposed cost, etc., on individual slips. Ideal for securing new business leads. Hundreds of items, total monthly cost only \$10. Don't delay, subscribe today. ARCHITECT & ENGINEER, Room 618, 68 Post Street, San Francisco, California. Phone DOuglas 2-8311.

**PHOTOGRAPHS:** Specializing in building and construction photographs for publication, or historic records. For Industrial-Aerial-Publicity photography use the INDUSTRIAL PHOTO'S, Room 722, Hearst Bldg., San Francisco, Phone SUTter 1-6953.

**METAL WINDOWS** (Steel - Aluminum - Bronze). Large Stock, ALL TYPES. STEEL SASH SALES & SERVICE, Weehawken, N. J.

**ENGRAVING**—Good engravings are essential to a satisfactory job of printing reproduction. For the best, see Poor Richard Photo Engraving Co., 324 Commercial St., San Francisco.

# SISALKRAFT

REG. U. S. PAT. OFF.

*"More than a building paper"*

## THE SISALKRAFT CO.

205 West Wacker Drive  
Chicago, Ill.

55 New Montgomery Street  
San Francisco, Calif.

# HOGAN LUMBER CO.

Wholesale and Retail

## LUMBER

MILL WORK • SASH & DOORS

Office, Mill, Yard and Docks  
SECOND AND ALICE STREETS • OAKLAND, CALIF.  
Telephone GLencourt 1-6861

# CLINTON CONSTRUCTION CO. OF CALIFORNIA

## General Contractors

923 FOLSOM STREET • SAN FRANCISCO  
Sutter 1-3440

# SANTA MARIA INN SANTA MARIA, CALIFORNIA

FRANK J. McCOY, General Manager  
FERNAND E. PIMENTEL, Manager

On the  
Coast  
Highway  
between  
San  
Francisco  
and  
Los  
Angeles



American  
or  
European  
Plan  
•  
Old  
English  
Tap  
Room

## WESTERN ASBESTOS APPOINTED

The Western Asbestos Company, San Francisco, have been appointed northern California distributors for ALWINTITE aluminum windows, according to a recent announcement by Clarke E. Wayland, vice-president and sales manager.

The modern windows for residential construction are manufactured by the Aluminum Window Corporation, subsidiary of General Bronze, and are backed by more than thirty-five years experience in window manufacture.

Of extended, seamless tubular construction, they combine great strength and rigidity; no rust, and require no painting. The line includes many attractive features and are available in double hung windows in 12 stock sizes and four styles; full length aluminum screens and three sizes of panorama windows. Available to home builders now.

## NAMED VICE PRESIDENT

J. G. Jordan, San Francisco, has been appointed vice president of marketing for the Shell Oil Company, succeeding L. G. McLaren, retired.

He was formerly sales manager of the company.

## VENETIAN BLINDS FOR FULL-WIDTH WINDOWS

Perhaps the most modern feature of today's architecture is the emphasis on increased window space to private homes. Corner and view windows heretofore confined are a decided innovation in hotel construction, where utility is of primary importance.

The architect's problem in large structures is to retain utility in the face of modern treatment. While enjoying the benefits of freedom and light afforded by windows stretching the full width of the room, tenants and guests must be insured privacy.

Venetian blinds have been found to be the answer at Cincinnati's Terrace Plaza Hotel. Each guest room has a window spanning its full width, with full-width venetian blinds to control the admission of light and insure privacy.

The blinds have flexible metal slats, removable boxed balance for easy refitting and, because of their great width, were fitted with roller lift apparatus for easy elevation.

## GROUND BREAKING

Ground breaking ceremonies for a new United States Rubber Company tire distributing headquarters were observed recently in Los Angeles, California.

The building when completed will contain 180,000 square feet of floor space and will practically "double the capacity" of the Los Angeles tire plant, according to J. M. Miller, plant manager.

## BOOK REVIEWS PAMPHLETS AND CATALOGUES

### AMCOIL. The Complete Line of Air-Conditioning Units. American Coils Company, Newark, N. J.

A new illustrated catalog covering two complete lines of air-conditioning including remote and self-contained models of both floor and wall types, as well as duct-type coil for use in conjunction with any forced air conditioning system.

Contains complete specifications and engineering data, also handy new air conditioning calculator chart. Copies free from publisher.

### GUIDE FOR PLANNING SCHOOL PLANTS. Published by National Council on Schoolhouse Construction. Distributed through H. C. Headden, State Department of Education, Nashville, Tenn. Price \$1.00.

Part I of the pamphlet is devoted to the proceedings of the 23rd Annual Meeting of the National Council on Schoolhouse Planning, while Part II is entitled "Guide For Planning School Plants."

The pamphlet deals with all phases of school plant planning including site selection and development, material on elementary and secondary classrooms, specialized rooms, general facilities such as administrative units, cafeterias, gymnasiums and service facilities including fire protection, sanitation, heating and ventilating.

Mechanical and electrical engineers will be interested in data devoted to school lighting.

### "INDUSTRY NEED NOT BE UGLY". National Landscape Nurseryman's Association, P. O. Box 313, Niles, Michigan.

A well illustrated booklet showing many attractive examples of landscaping industrial and commercial buildings. Copies may be obtained from the publisher at Niles, upon request.

### CONCRETE PIPE LOAD SUPPORTING CAPACITY, Under Minimum Cover Conditions. American Concrete Pipe Ass'n, 228 N. La Salle Street, Chicago 1, Ill. PRICE 10c.

Bulletin No. 73, is a report of a series of full scale tests under normal field conditions. It details the behavior of concrete pipe when it is laid close to the surface of the ground and subjected to heavy loads applied over a limited area. Tables are included.

Government payments to survivors of veterans are running over \$2,858,000 per month in California, Arizona, Nevada and Hawaii. National compensation, pension, and death benefit checks run over \$32-Million.

## VERMONT MARBLE COMPANY

Producers and Finishers  
of  
Domestic and Imported Marbles

525 MARKET STREET, SAN FRANCISCO  
Phone Sutter 1-6747

3522 COUNCIL STREET  
(Beverly Blvd. at Virgil Ave.)  
LOS ANGELES 4, CALIF.  
Telephone Fairfax 7834



### The Most Complete Line of STEELS and BUILDING MATERIALS Made by a Single Producer



See Sweet's Catalog File or write us for  
full information.

### REPUBLIC STEEL CORPORATION

GENERAL OFFICES: CLEVELAND, OHIO

DENVER, COLORADO . . . . . CONTINENTAL OIL BUILDING  
LOS ANGELES, CALIFORNIA . . . . . EDISON BUILDING  
SALT LAKE CITY, UTAH . . . . . WALKER BANK BUILDING  
SAN FRANCISCO, CALIFORNIA . . . . . RIALTO BUILDING  
SEATTLE, WASH. . . . . WHITE-HENRY-STUART BUILDING

## PACIFIC MANUFACTURING CO.

HIGH CLASS INTERIOR FINISH  
QUALITY MILLWORK

142 SANSOME ST., SAN FRANCISCO  
GARfield 1-7755

6820 MCKINLEY AVE., LOS ANGELES  
THornwall 4196

BUILDERS EXCHANGE, OAKLAND

## "AMERICAN - MARSH" CONDENSATION UNIT

Pumping  
Machinery  
for  
Every  
Purpose

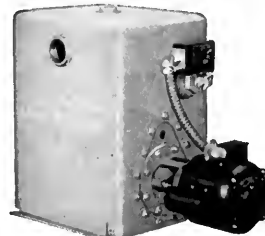

For Service  
Call  
DOuglas  
2-6794  
or  
MUtual 8322

**SIMONDS MACHINERY CO.**  
SAN FRANCISCO 816 FOLSOM  
LOS ANGELES 455 EAST 4TH

# DEFEAT SUMMER HEAT INSIDE HOMES

with

# KIMSUL\*

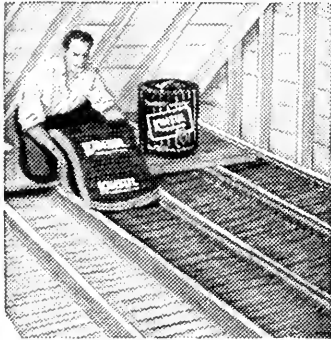

"Everybody talks about the weather but nobody does anything about it" isn't true any longer. Now you can do something about summer heat in your home . . . insulate the walls and ceilings with a blanket of many-layer KIMSUL and keep interiors at least 15 degrees cooler on the hottest days. Prefabricated KIMSUL offers uniform insulation coverage in both summer and winter. Greatly reduces fuel bills, too.

And KIMSUL is enduring . . . won't sag or settle . . . resists fire, moisture, termites. KIMSUL is easy to install. If you can handle a hammer, you can install KIMSUL.



DISTRIBUTED BY

**Pacific  
Coast  
Aggregates, Inc.**

Contact the nearest P.C.A. Office

**SAN FRANCISCO**  
400 Alabama St.  
KLondike 2-1616

**SACRAMENTO**  
16th and A Sts.  
Ph. 3-6586

**OAKLAND**  
2400 Peralta St.  
Higate 4-0770

**STOCKTON**  
1020 E. Main St.  
Ph. 8-8643

**FRESNO**  
2150 G St.  
Ph. 3-5168  
or  
414 P St.  
Phone 4-3065

**SAN JOSE**  
790 Stockton Ave.  
Ballard 8670

## IN THE NEWS

### SACRAMENTO SCHOOLS

Bonds have been voted and Harry J. Devine selected as the supervising and coordinating architect on a \$3,938,100 project for improving school buildings in Sacramento.

### SWIMMING POOL

A CPA permit has been granted to the Martinez Chamber of Commerce, Martinez, California, for the construction of a municipal swimming pool estimated to cost \$40,000.

### MECHANIZED WHEELBARROW

The new "Scootruck," capable of carrying a one-ton load at speeds up to 15 miles per hour has been announced by the NOVO ENGINE CO., of Lansing, Michigan.

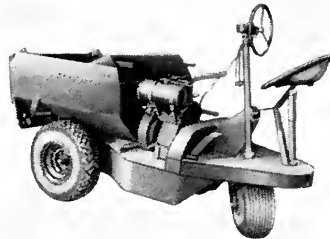

It is built to haul concrete, sand, bricks, motor and other building materials. Runs on airplane type tires and weighs 1000 pounds.

### NEW MANAGERS

A. P. Phal has been named manager of the W. P. Fuller & Co. South San Francisco laboratories, while Leonard Beltrami succeeds Mr. Phal as Manager of the Los Angeles laboratory.

Walter D. Jones will continue as Technical Director and advisor.

### PORTABLE WELDER

Available as a stationary or trailer unit, it is an N.E.M.A. rated machine of 200 amperes, with a Welding Service range of from 30 to 260 amperes.

Has standard size pneumatic tires.

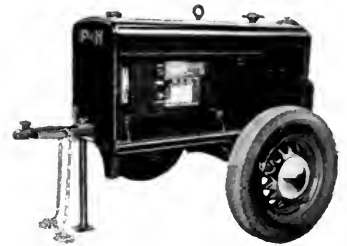

**P&H Model WN-200  
Trailer Welder**

Complete information by writing HARNISCHFEGER Corporation, Milwaukee, Wisconsin.

### RADIO STATION

A CPA permit has been granted for the construction of a radio broadcasting station near Vallejo, California, by the Calif-Nevada Broadcasting Company of Reno, Nevada. The stations call letters will be KOLO.

**Brown's**  
**VAPORSEAL**

The resilient building paper creped to S-T-R-E-T-C-H

Quality Products Since 1895  
**ANGIER PACIFIC CORPORATION**  
55 NEW MONTGOMERY ST. • 7424 SUNSET BOULEVARD  
SAN FRANCISCO 5, CALIF. • LOS ANGELES 46, CALIF.  
A complete line of Angier products available from your building material dealer.

"There's still life in the old gray mare."

**DON'T** throw away those used paint brushes

## CABOT'S BRUSH CLEANER

*Positively removes old paint right down to the heel*

**GUNN CARLE & CO**  
20 POTRERO AVENUE • SAN FRANCISCO, CALIF.

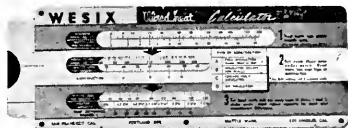

**WESIX** *Wiredheat* **CALCULATOR**  
 "Slide-rule" style, for quick computing of the correct WESIX Wiredheat SYSTEM for any house. Available to architects, engineers, contractors and dealers.

**WESIX ELECTRIC HEATER CO.**  
 390 First Street, San Francisco

## THE TORMEY COMPANY

GENERAL PAINTERS  
 AND DECORATORS

Phone UNderhill 1-1913

563 FULTON STREET  
 San Francisco

## MULLEN MFG. COMPANY

BANK, STORE AND OFFICE  
 FIXTURES—CABINET WORK  
 OF GUARANTEED QUALITY  
 CHURCH SEATING

Office and Factory:  
 60-80 RAUSCH ST., Bet. 7th and 8th Sts.  
 San Francisco  
 Telephone UNderhill 1-5815

*Fine*  
**ENGRAVINGS**

**POOR RICHARD**  
 PHOTO ENGRAVING CO.  
 320-324 COMMERCIAL STREET  
 SAN FRANCISCO, CALIF.

### FARM MACHINERY BUILDING

A \$166,000 farm machinery sales and service building will be built in Woodland, California, by Stolte, Inc.

### RACE TRACK

Swinerton & Walberg, Oakland, California, contractors have been awarded a \$250,000 contract for rehabilitation of the race track, grandstand, clubhouse and stables at Albany, California.

### DRY CLEANER

Smudges, fingerprints, and dust on drawings, blueprints, maps and charts are easily removed by



DRAW-KLEEN which is sprinkled on and rubbed over surface by palm of the hand.

The new product is being introduced by CRAFTINT.

### INSECTICIDE

Bids are being taken for construction of insecticide plant at Martinez, Calif., for the Shell Development Co. Cost estimated at \$650,000. Plans prepared by the engineering department of the owner.

### DRUG STORE REMODEL

Thrifty Drug Stores, a drug chain with main offices in Los Angeles, will soon authorize a \$100,000 remodeling job on their Fresno (Calif.) store. Webber & Co., of Los Angeles, are the structural engineers.

The giant new University of California cyclotron has produced atomic bullets ten times more powerful than any previously accelerated.

## DINWIDDIE CONSTRUCTION COMPANY

**BUILDERS**

CROCKER BUILDING  
 SAN FRANCISCO



## HERRICK IRON WORKS

STRUCTURAL STEEL  
 REINFORCING STEEL

18TH AND CAMPBELL STS.  
 OAKLAND, CALIF.  
 Phone GLencourt 1-1767

Phone GARfield 1-1164

## Thomas B. Hunter

*Consulting Engineer*

DESIGNER OF HEATING  
 AIR CONDITIONING  
 VENTILATING AND WIRING  
 SYSTEMS, MECHANICAL  
 AND ELECTRICAL EQUIP-  
 MENT OF BUILDINGS

41 SUTTER STREET  
 ROOM 710  
 San Francisco California

## Scott Company

HEATING . . PLUMBING . . TILE



243 MINNA STREET  
 SAN FRANCISCO  
 Phone EXbrook 2-6741

## George F. Brayer

ELECTRICAL  
CONTRACTOR

166 Seventh Street  
San Francisco

Phone: Market 1-1761

## PITTSBURGH TESTING LABORATORY

Successors to  
SMITH, EMERY & COMPANY

*Testing and Inspecting  
Engineers and Chemists*

Structural Materials, Structures  
Equipment, Pipe, Soils.

651 Howard St., San Francisco 5  
EXbrook 2-1747

## A. F. MATTOCK CO.

*Builders*

★

212 CLARA STREET  
SAN FRANCISCO

## INDEPENDENT IRON WORKS

Steel Buildings  
Service Stations  
Steel Storage Tanks  
Fabricated Plate Work  
Steel & Sheet Metal Products  
Fabricated Structural Steel  
Steel Distributors

Eighth & Pine Sts. Oakland, 7

## Index to Advertisers

ALADDIN Heating Corp.	48
ANGIER Pacific Corp.	46
ARCHITECTS Reports	42
BASALT Rock Company	Back Cover
BAXTER & Company, J. H.	36
BRAYER, Geo. F.	48
CAMP, J. & Company	25
CAHILL Bros.	24
CLASSIFIED Advertising	43
CLEVELAND Wrecking Co.	25
CLINTON Construction Company	44
CORY & Joslin, Inc.	23
CROCKER First National Bank	42
DETROIT Steel Products Co.	7
DINWIDDIE Construction Co.	47
FEDERAL Ornamental Iron & Bronze Co.	26
FORDERER Cornice Works	42
FINK & Schindler Co.	11
FULLER, W. P. Co.	8
GLADDING, McBean Inside Front Cover	
GERWICK, Ben C., Inc.	24
GUNN, Carle & Company	46
HANKS, Inc., Abbott A.	48
HAWS Drinking Faucet Company	5
HERRICK Iron Works	47
HOGAN Lumber Company	44
HUNT, Robert W., Company	48
HUNTER, Thos. B.	47
INDEPENDENT Iron Works	48
JUDSON, Pacific-Murphy Corp.	29 & 40
KRAFTILE Company	12
MATTOCK, A. F.	48
MICHEL & Pfeffer Iron Works	Inside Back Cover
MULLEN Mfg. Co.	47
MULLER Brass Co.	2
NORTHERN California Electrical Bureau	35
PACIFIC Coast Aggregates, Inc.	46
PACIFIC Coast Gas Association	1
PACIFIC Electrical & Mechanical Co.	27
PACIFIC Manufacturing Company	45
PACIFIC Portland Cement Company	*
PACIFIC Telephone & Telegraph Co.	33
PERMANENTE Cement Co.	10
PITTSBURGH Testing Laboratory	48
POOR RICHARD Engraving	47
READYMIX Concrete Co., Ltd.	26
REMILLARD-Dandini Co.	48
REPUBLIC Steel Corporation	45
SANTA Maria Inn	44
SCOTT Co.	47
SIMONDS Machinery Company	45
SIMPSON Logging Co.	6
SISALKRAFT Company	44
SMITH & Daneri	25
SMOOT-Holman Co.	37
STANLEY Works, The	*
SULLIVAN, D. J. & T.	27
TAYLOR Co., Halsey W.	34
TORMEY Company, The	47
U. S. BONDS	9
VERMONT Marble Company	45
WESTERN Asbestos Company	30
WESIX Company	47
WOOD, E. K., Lumber Company	36

\*Indicates Alternate Months

## A L A D D I N

### Heating Corp.

Specializing in  
QUALITY HEATING  
EQUIPMENT

2222 San Pablo Avenue

OAKLAND

TWinoaks 3-1022

## ABBOT A. HANKS, INC. Engineers & Chemists

INSPECTING — TESTING — CONSULTING  
CONCRETE • STEEL • MATERIALS  
CHEMICAL AND TESTING  
LABORATORIES  
• RESEARCH AND INVESTIGATION •

TESTS OF STRUCTURAL MATERIALS  
DESIGN OF CONCRETE MIXES  
SHOP AND ERECTION INSPECTION OF  
STRUCTURES AND EQUIPMENT  
INVESTIGATION OF STRUCTURES  
AND MATERIALS  
TESTS AND INVESTIGATION OF  
FOUNDATION SOILS  
FIRE RESISTANCE AND INSULATION  
TESTS

624 Sacramento Street, San Francisco

## Robert W. Hunt Company ENGINEERS

Inspection • Tests • Consultation

Schools and Other Structures  
Are Built as Designed

*When Construction Materials are  
Inspected at point of Manufacture  
and during Erection by*

ROBERT W. HUNT COMPANY

*Cement, Concrete, Chemical, Metallurgical,  
X-Ray and Physical Laboratories*

Chicago • New York • Pittsburgh  
Los Angeles • All Large Cities  
San Francisco, 251 Kearny Street

## REMILLARD-DANDINI Co.

Brick and  
Masonry Products

★

400 MONTGOMERY STREET  
SAN FRANCISCO, CALIF.

# ARCHITECT AND ENGINEER

JACKSONS FURNITURE STORE Sacramento, California

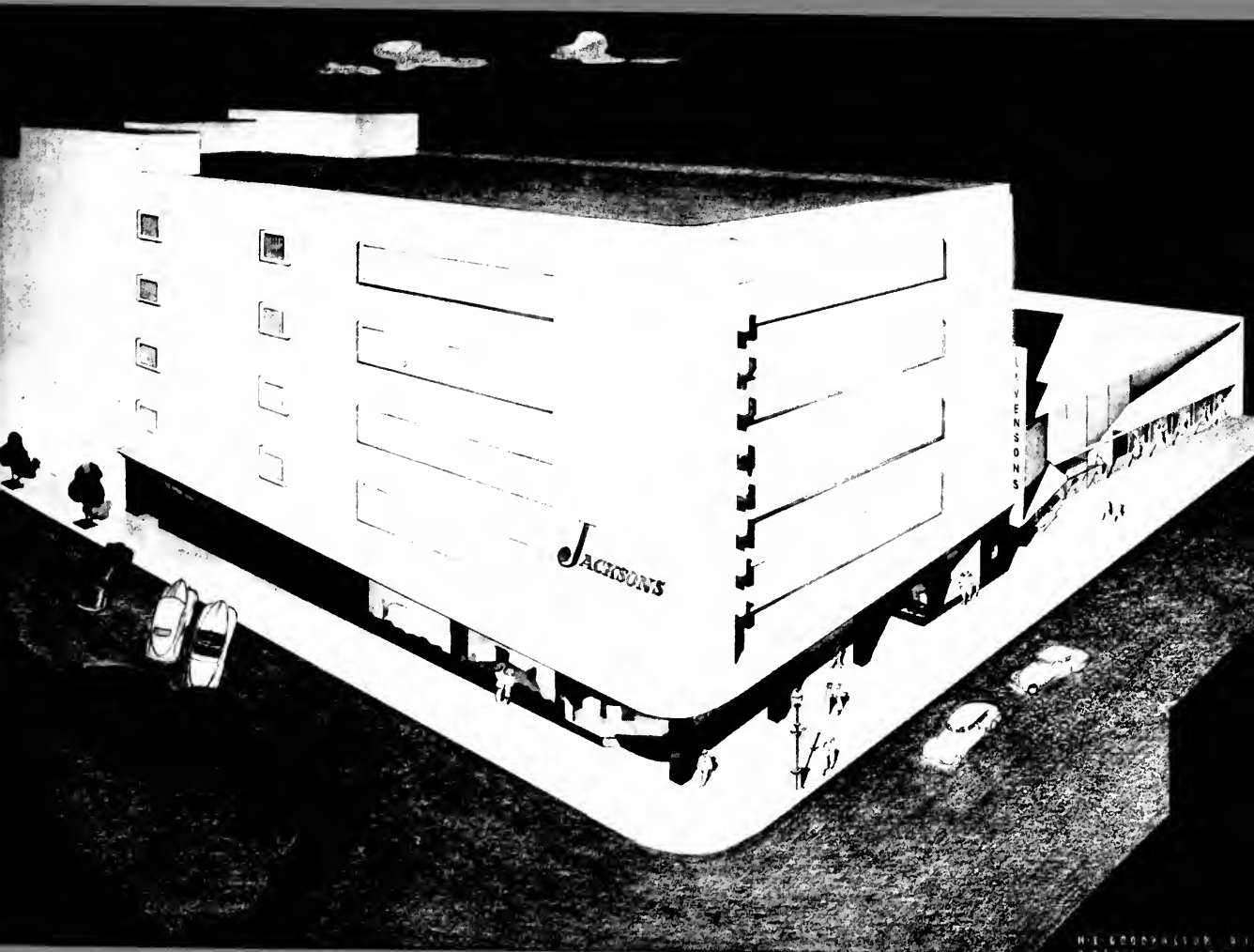

SEPTEMBER

1947

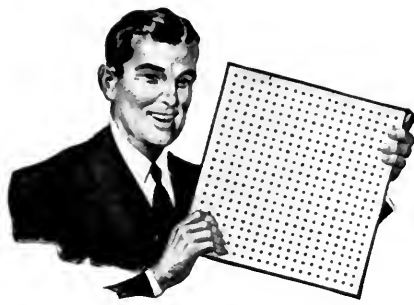

# OVER 1000 YEARS of Combined Acoustical Experience

... At Your Service Through Western Asbestos Co.  
Your Acousti-Celotex Distributor

MORE THAN 1000 years of combined experience, gained in over 100,000 installations—this is the great reservoir of practical knowledge available to you *only* through the Acousti-Celotex\* Distributor Organization of which Western Asbestos Co. is your representative.

This knowledge has been gained in good company. For the nationwide Acousti-Celotex group has collaborated with hundreds of architects in effecting solutions to noise quieting problems.

Every day the men of this organization are helping to solve such problems as:

- How to diagnose acoustical and noise quieting difficulties . . .
- How to reduce distracting noise to a gentle hush . . .
- How to design architecturally for optimum acoustics . . .
- How to be sure of mechanical perfection in the proper acoustical material and its application . . .
- How to make sure of the acoustical installation's perfect appearance and continued satisfactory performance through the years.

Every man in this nationwide organization is hand picked. He is thoroughly trained in sound-conditioning practice. As a result, when you turn a job over to him, you know it will be trouble-free.

No matter how much or how little assistance you may need, Western Asbestos Co. is willing and able to help you without obligation. This extra service in no way affects their ability to compete on the smallest or the largest job you may have. That service is the unwritten *plus value* that goes with every specification for Acousti-Celotex.

A phone call or a note will bring a trained sound-conditioning expert to you from Western Asbestos Co.'s staff.

## WESTERN ASBESTOS CO.

DISTRIBUTORS • ENGINEERS • CONTRACTORS

SAN FRANCISCO: 675 TOWNSEND STREET, HEMLOCK 4884

OAKLAND: LATHAM SQUARE BUILDING, TEMPLEBAR 7474

SACRAMENTO: 1224 EYE STREET, SACRAMENTO 2-8993

FRESNO: 1837 MERCED STREET, FRESNO 3-3277



Sound Conditioning with  
**ACOUSTI-CELOTEX**

\* Perforated Fibre Tile REG. U. S. PAT. OFF.  
SINCE 1923



# ARCHITECT

Vol. 170 No. 3

# AND ENGINEER

ARCHITECTS' REPORTS—Published Daily  
Telephone DOuglas 2-8311

E. H. WILDER  
Editor

MARK DANIELS, A.I.A.  
Associate Editor

JOHN S. BOLLES, A.I.A.  
Book Reviews

MICHAEL GOODMAN  
Post-War Planning

E. N. KIERULFF\*  
Ass't Editor  
\*In the Service



Contents for

## SEPTEMBER

COVER PICTURE: Jacksons Furniture Store, Sacramento, California  
(See Page 20)

### ARTICLES AND MISCELLANEOUS TEXT

EDITORIAL NOTES . . . . .	4
NEWS AND COMMENT ON ART . . . . .	10
FOUR MODERN INTERIORS, Designed by Klaus Pfeffer . . . . .	13
LANDSCAPE—UNITED AIR LINES MAINTENANCE BASE, San Francisco By WAYNE W. GRAY, A.I.A. . . . .	18
JACKSONS FURNITURE STORE, Sacramento, California . . . . . HERBERT E. GOODPASTOR, Architect	20
EL RANCHO SACRAMENTO, Sacramento, California . . . . . By FRANK W. GREEN, Architect	25
DESIGN OF AN AUTOMOBILE SALES AND SERVICE BUILDING, Santa Rosa, California . . . . . By C. A. CAULKINS, JR., A.I.A.	28
A. I. A. ACTIVITIES . . . . .	31
WITH THE ENGINEERS . . . . .	32
DRAMA IN PROFESSIONAL PRACTICE By ELMER GREY, Architect . . . . .	35
HEADLINE NEWS & VIEWS . . . . . By E. H. W.	36
IN THE NEWS . . . . .	37, 47
LANDSCAPE ARCHITECTURE, Notes of the Profession . . . . .	38
ESTIMATOR'S GUIDE, Building and Construction Materials . . . . .	41
BUILDING TRADES WAGE SCALES, Northern and Central California . . . . .	43
CLASSIFIED ADVERTISING . . . . .	43
BOOK REVIEWS, Pamphlets and Catalogues . . . . .	45
INDEX TO ADVERTISERS . . . . .	48

ARCHITECT AND ENGINEER (Established 1905) is published on the 15th of the month by The Architect and Engineer, Inc., 68 Post St., San Francisco 4; Telephone EXbrook 2-7182. President: K. P. Kierulff; Vice-President and Manager, L. B. Penhorwood; Treasurer, E. N. Kierulff.

Los Angeles Office: Wentworth F. Green, 6605 Hollywood Blvd., Los Angeles 28, Telephone HEMPstead 3171.

Entered as second class matter, November 2, 1905, at the Post Office in San Francisco, California, under the Act of March 3, 1879. Subscriptions United States and Pan America, \$3.00 a year; \$5.00 two years; foreign countries \$5.00 a year; single copy 50c.



# EDITORIAL NOTES

## ARCHITECTS CONVENTION AT CATALINA ISLAND

The Second Annual Convention of the California Council of Architects and the 20th Annual Meeting of the Architects of California scheduled for Catalina Island on October 1 to 4th, is an event of more than passing interest.

The fact that the Architects of California have been cooperating in a professional program for some 20 years is important, but the conference particularly emphasizes that as a result of such professional harmony and promulgation of mutual interests, the group have progressed considerably with formation of the California Council of Architects and its affiliation with the American Institute of Architects which maintains general offices in Washington, D. C., and represents the architectural profession nationally.

Architecture has always held a high place as the true expression of the life and culture of a people, a locality, and a period of time. Each generation of Architects faces its own challenge of the future, and many of those attending the Catalina Island conferences will be representing "today's" trends as well as those practiced during the past quarter of a century.

It is the obligation of every Architect to take an active part in his professional organization; there is no better guarantee of present and future opportunities than a well organized, understanding, profession.

\* \* \*

THE COMMUNIST DOCTRINE, if not challenged boldly and continuously, will increasingly threaten free enterprise.

\* \* \*

## SPENDERS

Americans are pretty well recognized the world over as "free spenders" and it seems to make little difference whether the spending money is "cash-in-hand" or "on the cuff".

Numerous financial authorities agree that the easing of strict war time curbs on installment buying has already resulted in a substantial increase in credit buying.

These same authorities supported by able economists express concern over the fact that the American people have borrowed some \$10.7-billion within the past few months to buy automobiles, refrigerators, radios, and other "essential" commodities on a "dollar down, and the rest of your life to pay" basis.

It is pointed out that during the period of 1935-39 the national consumer credit average but \$6.4-billion, and while it is acknowledged a portion of the current increase in loans is due to higher prices, there is no denying that item-for-item and dollar-for-dollar present spending is ahead of 1941.

On an overall national basis, however, figures show that despite the trend towards free use of credit, less than eight per cent of the goods being bought by the people of America today, are being bought on the installment basis.

\* \* \*

California expects to spend, through the Division of Highways, approximately \$76,000,000 yearly for new state highway construction. This program represents a favorable market for engineers, labor, and materials.

\* \* \*

## OPPORTUNITIES AHEAD

The future holds prospects of unprecedented opportunities for the architect—opportunities to be "of ever-increasing service to society" in a very real sense. There is not only a unprecedented need for his services, but there will be an effective demand; i.e., need backed up with both the will and the financial wherewithal to go ahead. Materials, manpower, machinery, and money, all will be available awaiting the decision to build and the architects' plans for building. There will be no lack of opportunity, but a profitable shortage of time to think things through. Creative, administrative, imaginative, realistic, farseeing, and informed architectural services will be needed as never before, to take advantage of the favorable conditions for great accomplishments which seem destined to prevail.

The volume of building needed is greater than ever before in our history. The demand for needed buildings will take years to satisfy. In addition there is a tremendous volume of repair, remodeling, and modernizing.

Abundant funds for financing are available in savings bank accounts, war bonds, savings and loan funds, and installment credit.

Many new spheres of activity and of service are open to architects. To face the whole realm of product design which needs their imagination and ingenuity, their sense of form and fitness. Excerpts from an article by Kenneth K. Stowell, A.I.A. appearing in "ARCHITECTURE A PROFESSION AND A CAREER," published by The American Institute of Architects, Washington, D. C.

# INVESTIGATE...COMPARE!

Investigation pays...

Comparison proves...

## **HAWS Superior Quality!**

You will assure long-term client satisfaction when you specify HAWS drinking water facilities for buildings you are designing now. Compare the features of available products. A thorough investigation will convince you, as it has many other architects and engineers, that HAWS Sanitary Drinking Fountains and HAWS Electric Water Coolers are most desirable for any building.

### **Some HAWS Features...**

#### **DRINKING FOUNTAINS**

- Smart, Modern Styling
- Dependable, Functional Design
- Finest Materials and Workmanship
- Sanitary... easy to clean
- Convenient Flow Regulators
- Wide Selection of Models

#### **ELECTRIC WATER COOLERS**

- Distinctive Design
- Large Cooling and Storage Capacity
- Dependable Refrigeration Units
- Low Cost Installation and Operation
- Perfect Sanitation... easy to clean top



Write today for full information on  
*Hauss Electric Water Coolers and  
Sanitary Drinking Fountains*



**Model No. 8F:** Popular Industrial Type fountain. Many other models from which to choose.

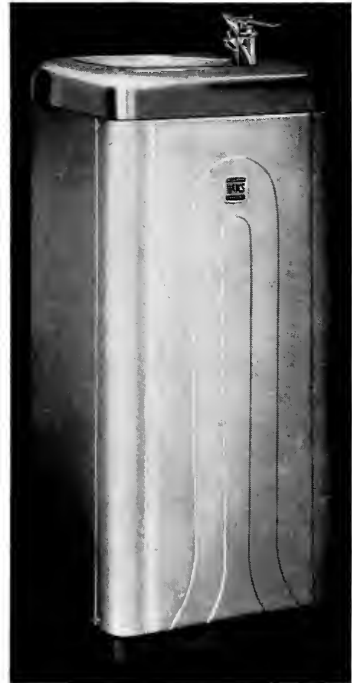

**Model No. 515:** Beautifully styled Electric Water Coolers. Ask for literature describing this and other models.

## **HAWS DRINKING FAUCET CO.**

1808 HARMON STREET (SINCE 1909) BERKELEY 3, CALIFORNIA  
Agents and Sales Representatives in All Principal Cities

# NOW IN PRODUCTION!



DISCUSS THIS  
NEW ACOUSTICAL TILE  
WITH YOUR NEAREST  
SIMPSON APPLICATOR

**ALLIED CONSTRUCTION & SPECIALTY CO., INC.**

8455 Melrose Ave.,  
Los Angeles 46, Calif.  
Phone: Walnut 0541

**ANGELES INDUSTRIES**

984 McGarry St.,  
Los Angeles, Calif.  
Phone: Vandike 1783

**ARIZONA SASH, DOOR & GLASS CO.**

657 West St. Mary's Road  
Tucson, Ariz.  
Phone: 1699

**CONSOLIDATED ROOFING & SUPPLY CO.**

520 South 7th Ave.,  
Phoenix, Ariz.  
Phone: 47888

**CONTINENTAL LUMBER CO.**

P.O. Box 2042, Boise, Idaho  
Phone: 450

**ELLIOTT BAY LUMBER CO.**

600 W. Spokane St.,  
Seattle, Wash.  
Phone: Elliott 8080

**ELLIOTT BAY LUMBER CO.**

Box 188—Union Gap Station,  
Yakima, Wash.  
Phone: 24671

**EXCHANGE LUMBER & MFG. CO.**

P.O. Box 1514, Spokane 7, Wash.  
Phone: Glenwood 1621

**FROST HARDWOOD LUMBER CO.**

Market of State St.,  
San Diego, Calif.  
Phone: F-7224

**LUMBER DEALERS, INC.**

T A Box 5222, Denver 17, Colo.  
Phone: Tobar 6141

**LUMBER DEALERS, INC.**

108 South Main St., Pueblo, Colo.  
Phone: 4881

**LUMBER DEALERS, INC.**

423 No. 33rd, Billings, Mont.  
Phone: 3911

**ACOUSTICS NORTHWEST**

Builders Exchange Bldg.  
Portland 4, Ore.  
Phone: Atwater 6443

**UTAH LUMBER CO.**

333 W. 1st So.,  
Salt Lake City 9, Utah  
Phone: 4-4318

## SIMPSON ACOUSTICAL TILE NOW BEING DELIVERED TO APPLICATORS

**A**FTER months of research, planning and testing, Simpson Acoustical Tile is now in production in our ultra-modern new mill at Shelton. Made from the incomparable Douglas fir fiber by an improved manufacturing process, this new acoustical material has higher quality, better performance and a more pleasing appearance. A newly developed machine *drills* clean-cut perforations, eliminating fuzzy edges, thus permitting repeated paintings without impairing acoustical properties. Architects will find that the new Simpson Acoustical Tile, with its clean-drilled perforations, high uniformity in texture and dimensions, and bevels finished in the same attractive Oyster-white as the surface, will give greater ceiling beauty and more efficiency in solving noise-quieting and acoustical problems.

WOOD FIBER DIVISION • SIMPSON LOGGING COMPANY

Plant at Shelton, Washington  
Sales Division  
1065 Stuart Bldg., Seattle 1, Wash.



**Simpson**  
QUALITY SINCE 1895

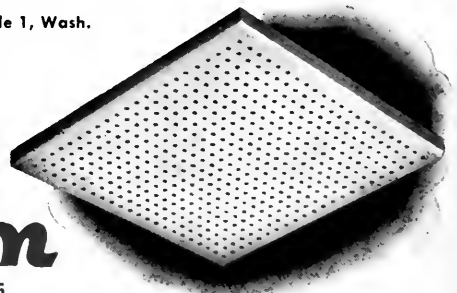

# ACOUSTICAL TILE

ARCHITECT AND ENGINEER

*How to meet a specific window need - Economically*

**SELECT FROM THE NEW STANDARDIZED FENCRAFT WINDOWS**

**CASEMENT . . . PROJECTED . . . COMBINATION**

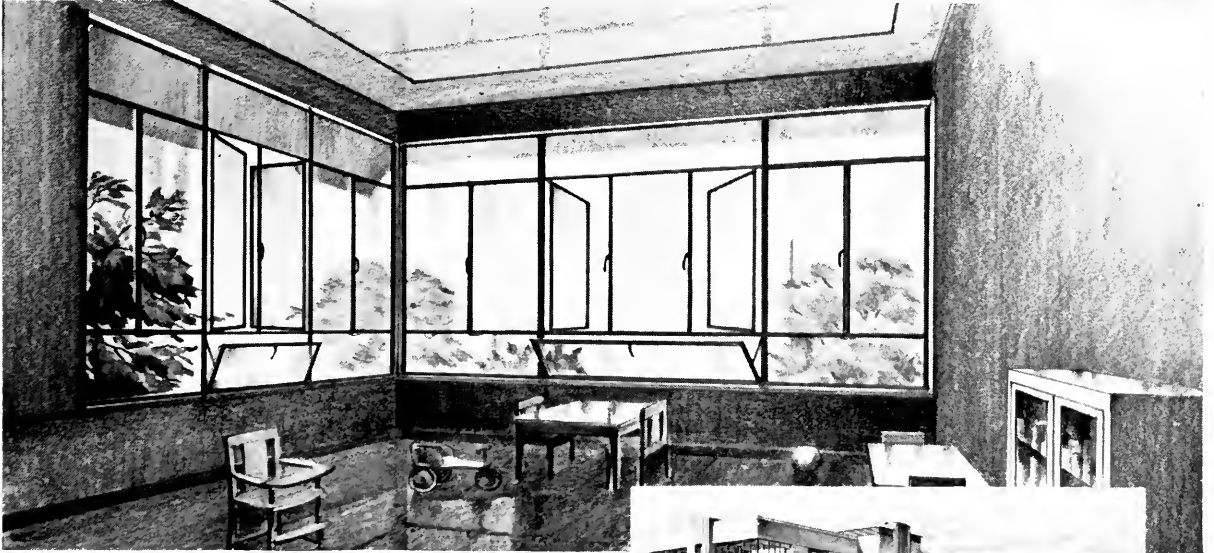

*Suggestion:* In a hospital's nursery, combine units of Fenecraft Standard Intermediate Combination Windows, such as types 636 and 616 (illustrated). Note that sill vents, opened, guard against drafts, prevent children from falling out.



A hospital's nursery, for example, needs ample daylight for young eyes . . . with windows low so youngsters can see out . . . with abundant fresh-air ventilation . . . with sill vents so designed that when open the children cannot fall out of windows.

Such windows are offered in the three new lines of Fenecraft units which provide new high quality, lower cost and important installation economy.

Built of specially-designed steel casement sections, by craftsmen in the shops of America's oldest and largest steel window manufacturer,

all Fenecraft Windows beautify both the outside and the inside. They provide permanently easy operation, safe cleaning, lasting weather-tightness, firesafety and low maintenance cost.

Types and sizes are standardized, for singular economy. Installation cost is minimized by the use of uniform installation details, plus the coordination of window dimensions with those of wall materials.

Eminently suited for America's finest hospitals, Fenecraft Windows are now being shipped to many localities. Ask your architect about them. For product details, mail coupon below.

*Fenestra*



**FENCRAFT INTERMEDIATE STEEL WINDOWS**

Detroit Steel Products Company  
Dept. AE-9  
2260 East Grand Blvd.,  
Detroit 11, Michigan

Please send me data on types and sizes of the new Fenecraft family of Fenestra Windows:

Name \_\_\_\_\_

Company \_\_\_\_\_

Address \_\_\_\_\_



**One accident can cost  
your client more —**  
than the entire cost of scientific safety  
through modern Color Engineering

### Fuller Floor Finishes stand the gaff

Customer tests prove superiority in open competition of Fuller floor preservatives for institutions, for gymnasiums, arenas, schools, industrial plants, public buildings.



### NEW — Red LZI Metal Primer

Composite LZI (lead, zinc, iron) saves *three* ways on structural steel — lower initial cost, lower application cost, longer rust inhibition. Make us prove it!

Safety *rules* are not enough! Safety must be *created*—accident prevention *practiced*. Color Engineering by Fuller corrects bad light and drab surroundings, points out danger areas—lifts employee morale, promotes good housekeeping, increases work efficiency, and cuts accident costs.

Our trained representative will give you details, help you specify color systems. No obligation.  
W. P. Fuller & Co. San Francisco.  
Branches and Dealers throughout the West.

FREE—24-page book, "Color Engineering by Fuller"—full color photos, diagrams, symbols.  
Put it in your file.



# DEPENDABLE



A  
"PACIFIC  
PRODUCT"

*Produced by*

**PACIFIC PORTLAND  
CEMENT COMPANY**

San Francisco • Los Angeles  
Portland

*Sold by*

**YOUR BUILDING  
MATERIALS DEALER**

# UNIFORM - TIME TESTED

# NEWS AND COMMENT ON ART



**ARRIVAL OF THE UTAH PIONEERS in the Salt Lake Valley  
in 1847 by Paul Clowes, well-known Salt Lake City artist**

The painting depicts the covered wagons of the pioneers as they came down out of the Wasatch Mountains into the great Salt Lake Valley on July 24, 1847. The valley at that time was a sage covered desert, the only inhabitants being an occasional tribe of Indians. Today the valley has developed into a great agricultural and industrial area and this year is celebrating its Centennial anniversary.

(Photo State of Utah, Dept. of Publicity and Industrial Development.)

## **M. H. DE YOUNG MEMORIAL MUSEUM**

Walter Heil, director, has announced the following events for September:

A one man show of comparatively recent work by **LAWRENCE MURPHY**, consisting of twenty oils and twenty drawings. Subject matter includes study of horses, riders and bathers, and landscape.

Exhibits of oils, drawings, and prints, by **RUDOLPH C. VON RIPPER**. Austrian artist, executed for the most part during the War years and projecting salient episodes and subjects of contemporary life under the sway of war's turmoil.

Engravings and Etchings by **KUNO BRINKS**,

noted contemporary Dutch artist, showing more than two score of his etchings, engravings and drypoints.

**MARK SPONENBURGH** exhibition comprising 15 works of sculpture.

Photographs by **ELLEN BRANSTEN**, showing numerous still lifes, portraits and scenes of San Francisco showing a lively cross-section of city life.

## **CALIFORNIA SCHOOL OF FINE ARTS**

Fall classes for Children have been resumed with drawing, painting, and sculpture being taught in two sessions. Ruth Cravath Wakefield will in-



M. H. DE YOUNG MEMORIAL MUSEUM

Exhibit of Works of

# MARK SPONENBURGH

Born in Michigan of Dutch-American parents, he studied at Wayne University, Detroit Society of Arts and Crafts, Cranbrook Academy and Ecole des Beaux Arts in Paris. He was the recipient of fellowships from Cranbrook, and the Tiffany and Bok Foundations. At present he heads the Department of Sculpture at the University of Oregon.

*The sculpture of Mark Spomenburgh is warmly personal, unaffectedly itself.*

*Dr. W. S. Baldinger*



**MADONNA . . . .**

**Black Walnut**

**MY WIFE . . . .**

**Plaster for Bronze**



struct the drawing and sculpture group, while Hasel Smith will head the painting and drawing classes. Classes will meet each Saturday morning from 9:00 to 12:00.

A special session for very young people will be held each Saturday 9:30 to 11:30 a.m. supervised by Mary Hiatt.

---

### SAN FRANCISCO MUSEUM OF ART

Exhibitions announced for September include BAY REGION RENTAL GALLERY PAINTINGS and SCULPTURE, opening September 15 through October 5. PAINTINGS by FOUR BERKELEY ARTISTS, Evelyn Bailey Brezee, Virginia Roberts, Lucretia Nelson and Albin Templeman, September 16 through October 5.

PHOTOGRAPHS of the ARCHITECTURAL and UNIT PLANNING WORKS, by Ernest Kump, Mark Falk and Alfred Christensen, September 10 through the 28th.

WALL PAPER DESIGN by PACIFIC COAST ARTISTS, Handprinted by James Kremble Mills, September 11 through October 5.

CHILDREN'S ART CLASSES will be resumed each Saturday morning September 20th. Ages 6 to 14, 10:00 to 11:30 a.m.

FOUR LECTURES, followed by the house tour will be presented by the Women's Board on Thursday afternoons, October 9 through November 6.

FAMOUS FILM SERIES each Tuesday evening at 8 o'clock.

---

### 1947-48 BENDER GRANTS-IN-AID

The Board of Trustees of the Albert M. Bender Memorial Trust announces that applications for the 1947-48 Bender Grants-in-Aid will be accepted during the months of August and September. \$1200.00 each in the fields of art and literature will be awarded. The grants, presented annually as a memorial to the late art patron whose name they bear, are intended solely for those wishing to engage in creative work in art or literature. Applications in the field of art are limited to painting and sculpture. Creative writing is to be interpreted in the broadest sense, except that it is not to be research in character.

The Grants-in-Aid are made without restriction as to sex, race, color, or creed. All applicants must have resided in central or northern California for at least two years.

The following Juries of Awards have been appointed by the Bender Memorial Fund Trustees, Dr. Monroe E. Deutsch, chairman: Jury in Art—Ernest Born, Leah Rinne Hamilton, Dr. Elisabeth Moses, Dr. Stephen C. Pepper, Clay Spohn; Jury

in Literature—Joseph Henry Jackson, Literary Editor of the S. F. Chronicle, and Professors James M. Cline, University of California, Elias O. James, Mills College, and John McClelland, Stanford University.

---

### CITY OF PARIS ART IN ACTION

A thoroughly interesting Group Show entitled: "Carnival" and comprising the work of some 25 artists of the Rotunda Circle will be presented in the Rotunda Gallery on the 4th Floor of the City of Paris, from September 17 to October 11.

In the Art in Action Shop, on the 5th Floor, the pictures of the Month will show the work of Dorr Bothwell. Exhibitions of Pottery by Harrison McIntosh and Mary Erckenbrack, and a special showing of Guatemalan Textiles will also be available to the public.

---

### EXHIBIT

Ernest J. Kump, A.I.A. Architect; Mark Falk, A. S.C.E., Structural Engineer, and Dr. Alfred Christensen, Planning Consultant, exhibited a display of Architectural, Engineering and School Planning at the San Francisco Museum of Art recently.

---

### NEW CANNERY

The Patterson (California) Products Company have awarded M. A. Little Co., San Francisco, a contract for construction of a \$150,000 cannery building at Patterson.

---

C. M. TEIGLAND, has been awarded a general contract for construction of a \$180,000 store building in Oakland. Fred L. R. Confer and R. G. Willis are the architects.

---

### ARCHITECTS MOVE

Douglas Dacre Stone and Lou B. Mulloy, Architects, have announced the opening of new offices at 619 California Street, San Francisco 8.

---

SWIMMING POOL Bonds were voted for construction of a \$150,000 natatorium at Vallejo, California. Harry J. Devine, Architect, Sacramento.

---

**NEW VETERAN HOSPITAL:** James I. Barnes Construction Company, San Francisco have been awarded the general contract for construction of a 250 bed general medical and surgical Veterans Hospital at Fresno, California, at an estimated cost of \$5,863,000.

---

JOSEPH LOSEKANN, Architect, is now located at Room 300 Elks Building, Stockton 1, California.



FOUR MODERN  
INTERIORS

designed by

Klaus Pfeffer

Photos by Roger Sturtevant  
Courtesy of "House Beautiful"



## A WOMAN'S BEDROOM

**BUILT IN FURNITURE** is tailored exactly to fulfill all of the owner's individual requirements including even a tiny kitchenette compartment concealed in the cabinet to the right of the windows.

Klaus Pfeffer's design was executed by

**A. J. YERRICK**

The Decorator was

**DORIS CONNER**



view towards wardrobe



## REMODELED BEDROOM IN A TWENTY-YEAR-OLD HOME



view toward the mirror wall

**WALLS OF GLASS AND MIRROR**  
create an illusion of spacious-  
ness in a very small (12 x 12)  
room. Woodwork is Redwood  
Plywood.

Klaus Pfeffer's design  
was executed by

**A. J. YERRICK**

The Decorator was  
**DORIS CONNER**



## BATH DRESSING ROOM FOR A MAN

A NINE-FOOT wardrobe and a seven-foot chest of drawers provide ample space. . . . The tiled shower has an electric fan in the ceiling which keeps the room free from steam.

Klaus Pfeffer's design  
was executed by  
A. J. Yerrick





## STUDY-DRESSING ROOM FOR A MAN

Mirrored closet doors reflect the view into the pines. Walls and ceiling are Douglas Fir. Floor and counter tops are battleship linoleum. Klaus Pfeffer's design was executed by A. A. Yerrick.

**ERNEST SHIBLEY**  
Interior Decorator

sleeping porch adjoins  
the dressing room



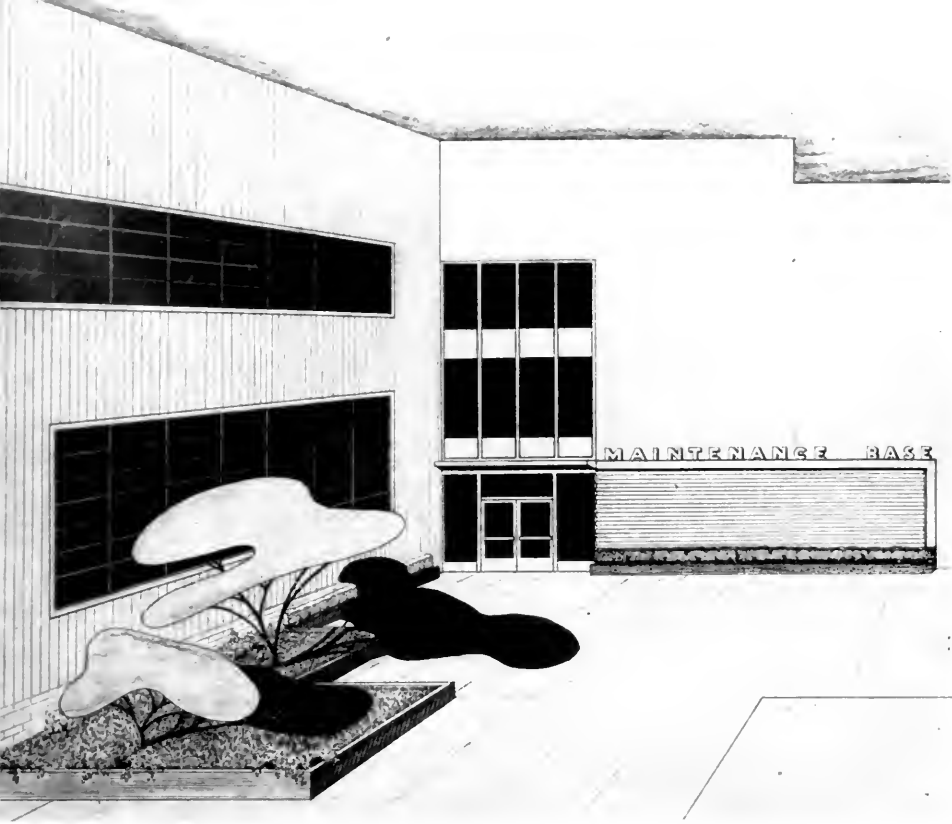

# UNITED AIR LINES MAINTENANCE BASE

San Francisco, California

**WAYNE W. GRAY, ALA**

**Landscape Architect and Designer**

**United Airlines, Inc.**

**Member Association of Landscape Architects**

United Airlines, as part of their tremendous expansion program, is constructing a new Maintenance Base at the San Francisco Airport. In accordance with their policy of thoroughness and excellence in planning and service it was deemed desirable to retain a Landscape Architect through the entire phase of construction not only to plan the landscaping but to act as coordinator on matters of interior color schemes, floor coverings, furnishings, and the design of particular architectural details.

The rather difficult site of the base presented a number of problems to the Landscape Architect. Very strong prevailing West winds; fire; dusty soil; and an unsightly slough called for special attention. The extent of the development and somewhat loosely located buildings and parking facilities hampered the system of circulation. With such considerations in mind the landscape program developed as follows:

**DUST CONTROL**

Due to the strong prevailing west winds some-



thing must be firmly attached to the soil to keep it in place and out of the buildings where delicate instruments are being checked, repaired, and installed. Even though the air is being filtered for dust in ionized chambers before entering the shops this extra precaution is necessary because of the large hangar areas. Ground covers of Ivy, Mesembryanthemum, and lawn will eventually cover all exposed, unpaved areas.

EROSION CONTROL

Filled soil must be kept where it belongs. All the airport buildings are sitting on concrete piles with a thin layer of dry fill below for an average of six feet. When the rains are heavy even the most carefully engineered drains are sometimes to no avail. A good plant cover successfully binds this soil and keeps the fill from completely disappearing into the bay.

GENERAL LANDSCAPING

The planting will consist of hardy ground covers and low, wind tolerant shrubs such as Acacia longifolia, Leptospermum leavigatum and Melaleuca. Some trees, as shown on the plan, will be grouped together to create mass effects and to protect each other from the strong winds. Monterey pine and Eucalyptus appear to be two of the few trees able to withstand such adverse conditions. Lawn will be used in special areas as shown in sketch No. 1.

The slough as shown on sketch No. 1 is to be screened as much as possible with Acacia longifolia. Eventually this unsightly slough is to be filled

in by the City of San Francisco as part of the master plan of the Airport.

The large parking lot to the North of the main building has been designed to accommodate all employee and visitors cars for this area and will eliminate all roadside and undesirable parking. A pedestrian bridge will connect the parking lot to the Maintenance Base.

ARCHITECTURAL DETAIL

The main entrance shown in sketches No. 1 and 2 is located on the protected side of the building. Careful architectural and engineering study was given to this area and the landscaping constantly kept in mind. Because of this a series of unavoidable manholes that had to be located in this area were so placed that a planting space was left and is shown on the sketches as the stepped-back wall. The landscaping was worked in architecturally on the facade by means of the planting boxes and will be reflected in the interior lobby with plant tubs.

Not only has careful thought and planning been expended on functional details and attractive outward appearance but all interiors, both office and shop working spaces, have been considered to provide the most pleasant working conditions. With the realization that high personnel morale is imperative to the maintenance of the standards of United Airlines, great care has been given to lighting, ventilation, and especially enjoyable color schemes.

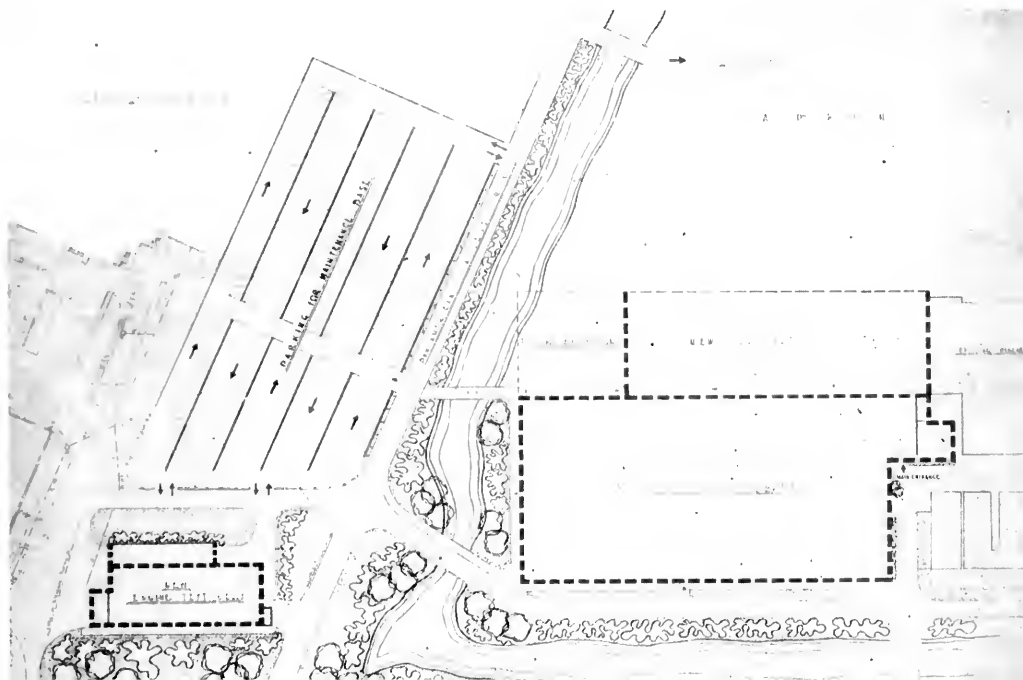



ENTRANCE FOYER

HERBERT E. GOODPASTER, Architect

# JACKSONS FURNITURE STORE . . . . Sacramento, California

HERBERT E. GOODPASTER, Architect

The Jackson Furniture Store, 14th and K Streets, Sacramento, California. Five floors—80 ft. x 160 ft.—with 14-foot ceiling heights. First floor columns and base are of light cream marble and the main wall is taupe with projection trim of all openings white. All openings are corrugated structural glass with indirect inside lights for night illumination.

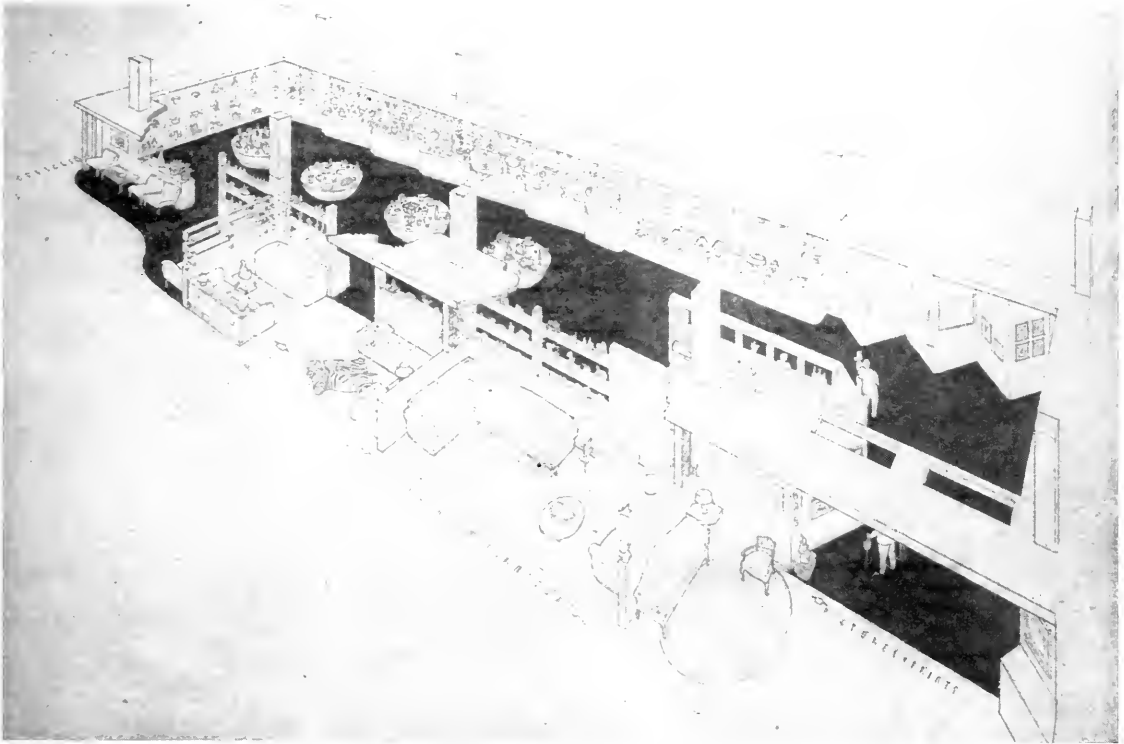

**GIFT SECTION . . .** Features diffused glass counter and table tops for ceramic display; private small print display room for customer print selection. End of section features a grid of shadow boxes for small display. Storage is behind the long wall.

**BELOW . . . First Floor Plan**

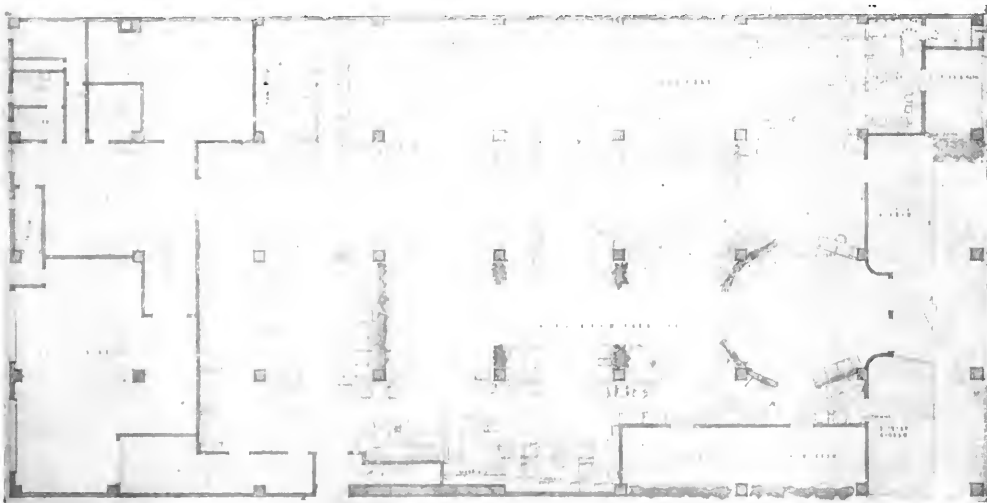

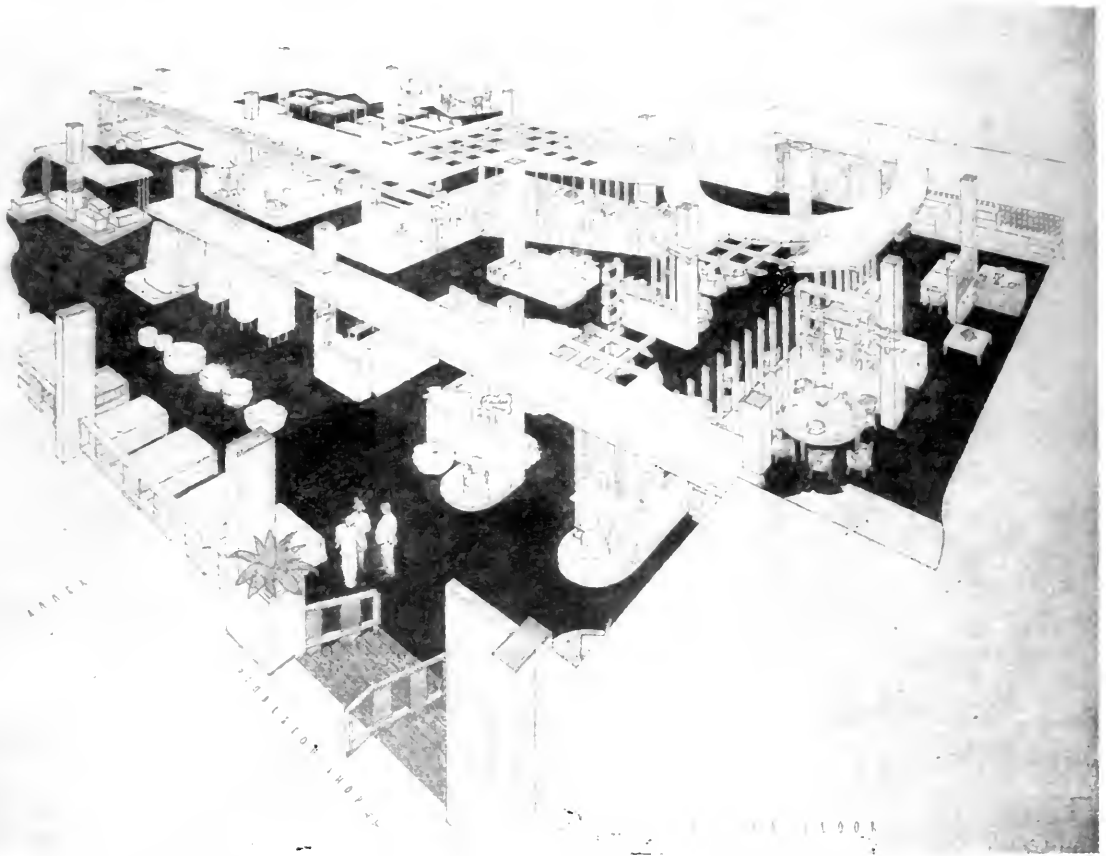

**SECOND FLOOR . . .** includes bedding, mattress, desks and dining room furniture displays. The grids over sections of group displays being to scale of merchandise. There is a liberal use of spot lights on feature displays.

**BELOW . . .** Second Floor Plan



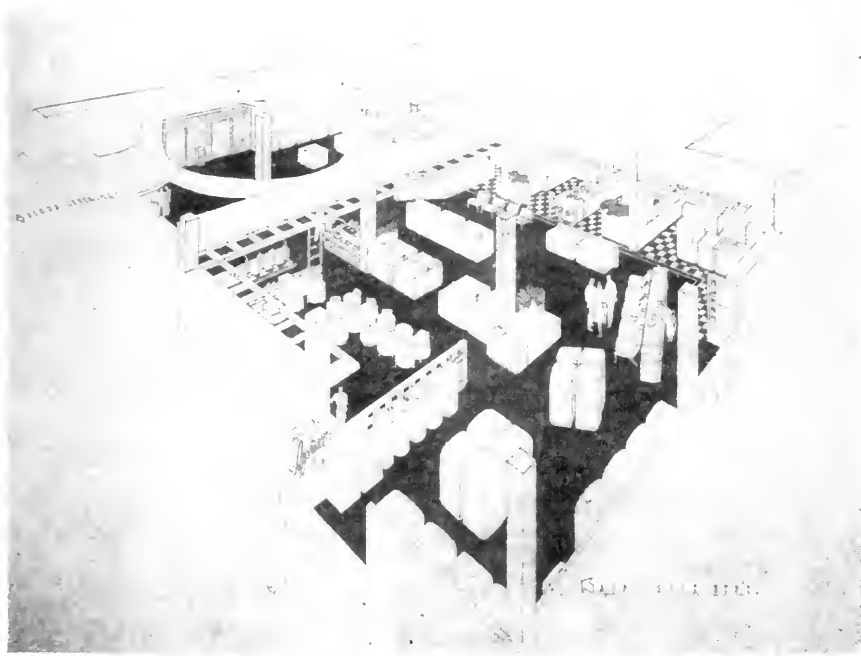

**THIRD FLOOR . . .** contains the Appliance Section, model kitchens, and model laundries. The area has been arranged so that the floor space may be used for cooking demonstrations and other special exhibit purposes.

**BELOW . . .** Third Floor Plan

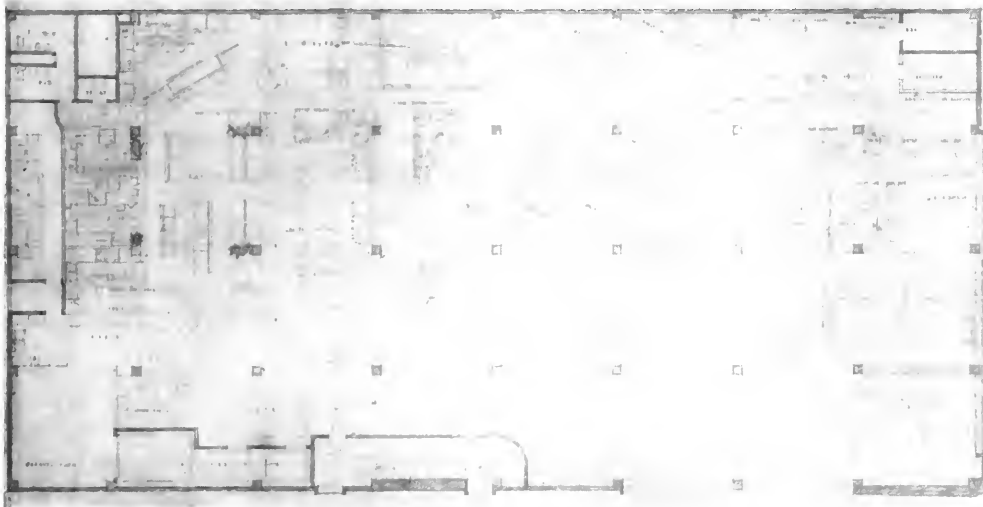

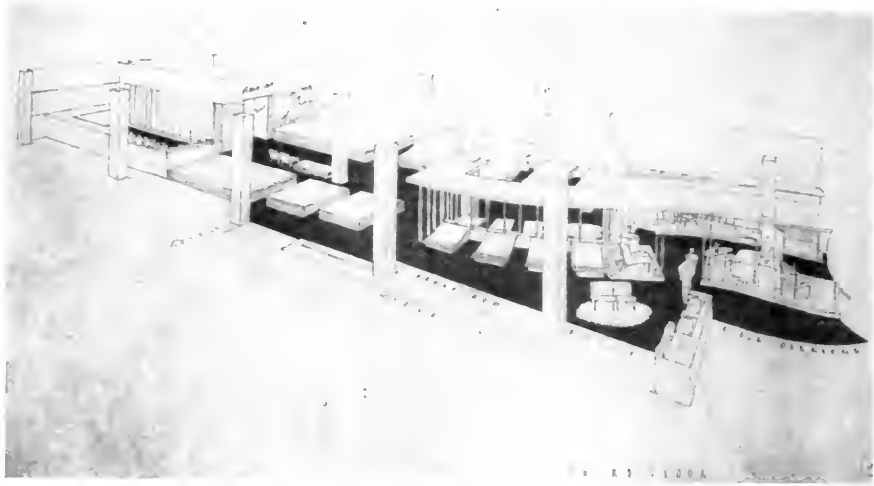

**RUG DEPARTMENT and Floor Coverings. Main sales are from extensive samples arranged in coordinated groups of different rug sizes.**

## **ARCHITECTURAL POINTS:**

The store has a total of 70,400 square feet and occupies a frontage of 80 ft. on K Street and 160 ft. on 14th Street, plus an annex of 80 ft. x 80 ft. to the west on the second floor.

The first three floors are at present to be used for the selling area, the top two floors to be used temporarily as repair rooms and small goods warehousing until such time as an additional warehouse can be built, at which time these floors will be converted to selling space.

Sales floors feature the sparing use of fixed structural corrugated glass in horizontal lines, lighted from the interior by diffused lights. Maple floors are laid over the concrete slab in all furniture sales areas, using scatter and home size rugs in furniture groupings. Main entrance features the use of planting boxes, and built in information counter.

All selling areas completely planned to suit the Jackson Furniture Co. requirements as to areas, sales volume, etc. Latest techniques are used making use of Unit Selling Ensembles instead of the old practice of the largest number of units per sales foot. It was found in developing the plan that useful, open, easily supervised floors were far more practicable, making use of group display and keeping the furniture in a more intimate, homey atmosphere.

Each floor was so planned to present a clear vision of merchandise, well arranged and classified, thus eliminating the usual buyer's confusion.

A study of traffic flow was made with origin at the elevator entrances and main entrance, and these studies determining to a great extent the location of the various departments and easy access.



AT THE SIGN OF THE WINDMILL

*Miles Berne, Photos*

# EL RANCHO SACRAMENTO

## Sacramento, California

By **FRANK W. GREEN, Architect**

The remodeled and enlarged El Rancho Sacramento is situated on National Highway No. 99, one mile out of the city of Sacramento. The site extends for 736 feet along the highway and runs to a depth of 800 feet. The administration building, including lobby, dining room, cocktail lounge and enclosed swimming pool, is reached by a broad drive in from the highway. Wide covers extend over the two entrances, one on each side of the trademark feature, the water tower and windmill.

Guest bungalows form a wide border to extensive lawns, plantings and driveways. Newly added are fifty-six guest room units in a second border and space is allowed for some seventy future rooms.

The windmill trademark is visible for a great

distance from both directions on the highway as well as from the swimming pool court inside. Exterior walls of the main building feature natural stone. Remodelling of the service station located on the highway was necessary to eliminate a clashing style and obstruction of the main building.

A particular problem was presented in the heating equipment being located in the water tower. This location created a severe fire hazard and had actually caused several small fires. The equipment itself was ridiculously inaccessible in that it could be reached only through a small trap door. All heating equipment was removed from the tower and a separate room added at ground level. Four additional equipment rooms were also added in the administration building.

# EL RANCHO SACRAMENTO . . .



**UPPER:** Distinctive half circle arch entry to the tile roof porches of the concrete wall guest room buildings.

**BELOW:** Guest room buildings, exposed rafters, concrete block pillars and tile roof add to the pleasure of El Rancho.







**SWIMMING POOL AND COURT: As seen through the plate glass wall of the main dining room. Wood sunvisors together with the extended roofs offer optional degrees of exposure to the sun.**

In the original layout of the main building, the access to the cocktail room took traffic through the dining room and gift shop in a circuitous route. By removing the partition between the foyer and gift shop, direct access was provided. Space in the dining room previously open to traffic was then converted to a poudre room, ladies rest room and check room.

Originally there was only one direct egress from the dining room, creating a fire hazard. An exit to the front drive was provided as well as double doors direct to the pool area and two corridor exits.

By extension of the dining room to include part of the previous patio area, the dining capacity was increased 100 per cent while intimacy of atmosphere was retained through placement of the dance floor on a lower level with additional booth surrounding. A bar was introduced at one end of the new dining space and an open barbecue at the other. A large private dining room overlooking the swimming pool was also added.

In the service area many alterations were made to provide five walk-in refrigerators, employees' dining room, three large storage rooms, a spacious receiving and work room and an enlarged store room.

To accommodate parking at peak periods, areas were increased approximately 100 per cent in sections around lawn space and along the highway.

An interesting addition is the manager's apartment which is located at the end of the front guest building. The living room windows of the apartment open into a clear view of the garden space, administration building and drive-in entrance. It consists of a living room, bedroom, kitchen, dinette, and bath. A Dutch fireplace has been placed in the dinette. Covered porches extend on two sides of the apartment.

A typical section of a guest room building shows the concrete block walls, exposed porch rafter and concrete block pillars. Floors are of concrete with solid carpet. Tile roofs and all steel sash are employed. A special architectural feature of the guest room building is the half circle arch entry to the long porches which breaks an otherwise monotonous facade.

Unusual ceiling design has been introduced in the main dining room, featuring tube lighting on top of beams running between ceiling joists. A mellow and homey atmosphere has been achieved through the generous use of copper planting boxes,

(See Page 46)



*Fred Mae, Photos*

# DESIGN OF AN AUTOMOBILE SALES AND SERVICE BUILDING

Santa Rosa, California

**C. A. CAULKINS, JR., A.I.A. Architect**

The problem and the solution in the design of a new sales and service building for Mr. W. W. Penhorwood, Dodge and Plymouth distributor of Santa Rosa, California embodied numerous interesting features.

FIRST. An entirely new site for the construction was selected which offered ample space for the building and utilities on level ground, and was ideally located with frontage on State Highway

No. 101 with rear access available on "B" Street.

## **THE PROBLEM**

The problem was to design a shop as efficiently arranged as possible with quick access to the Parts Department, elimination of all unnecessary moving of automobiles, and with good light, heat and ventilation.

The Show Room should be modest, but attractive, and show automobiles in the most convincing

# . . . AUTOMOBILE SALES & SERVICE

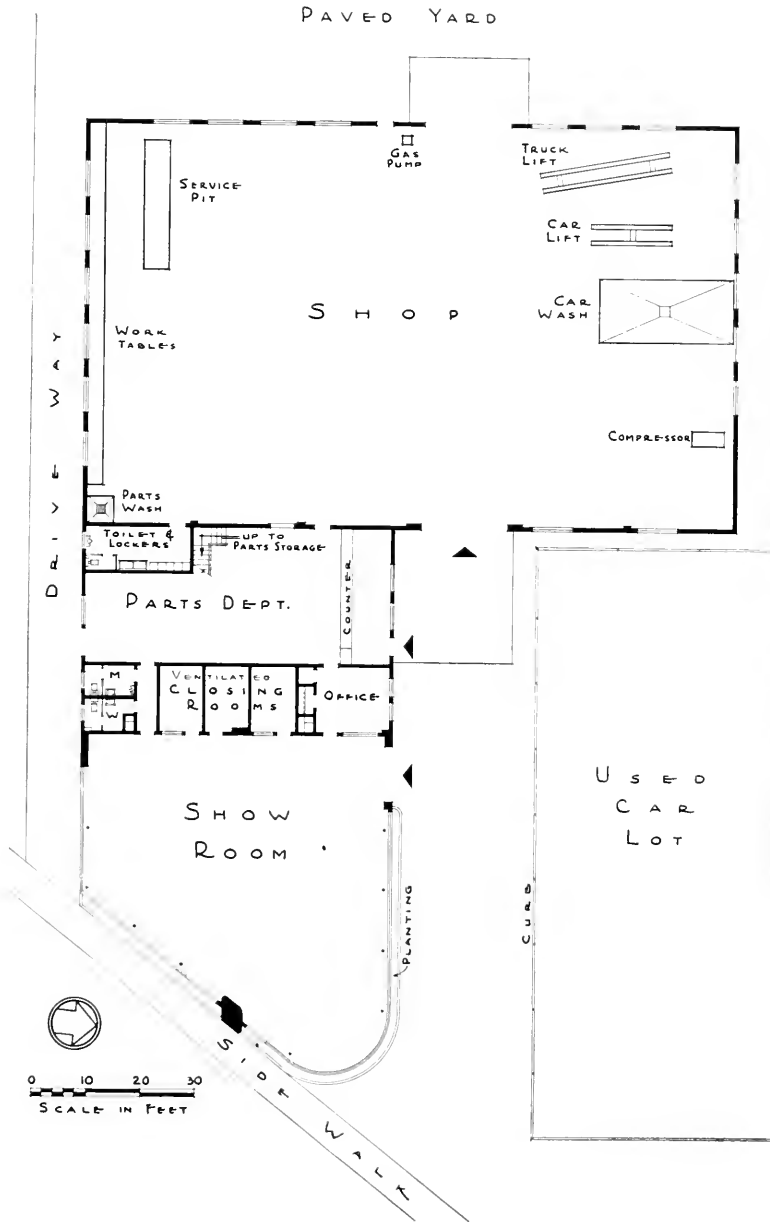

manner possible. The Show Room should be easily accessible to Closing Rooms, Offices and Toilets, and should be large enough to properly display trucks as well as pleasure automobiles.

The Parts Department should have quick access to the Shop, the Public and the main offices. The delivery of parts should not conflict with any circulation of regular business activities.

The Used Car lot should be conspicuous and

conveniently located with supervision from the main offices.

The Main Office should have supervision of the whole plant including the Used Car Department, Show Room, and Shop and should be well lighted, heated, and ventilated.

The Parking Area in the rear should not only have direct access to the Shop, but also access to "B" Street.

There should be large, dignified Signs, clearly

visible to the north and south bound traffic on State Highway No. 101.

## THE SOLUTION

The Solution, shown in the illustration on Page 28, the Plan on Page 29, and the illustration on Page 30, provides that all incoming automobiles and trucks are taken either directly into the Shop from State Highway No. 101 or straight through the Shop to the Parking lot in the rear at "B" Street. In this way the passage is clear at all times.

All incoming vehicles have to pass the Used Car area, the main Showroom, the Offices and the Parts department, so that all merchandise handled by the firm is conveniently displayed to customers entering the area regardless of the reason for their call.

The main Showroom, projecting towards the front of the building and facing the State Highway, is emphasized by means of large curved plate glass windows fifteen feet high. Most of the wall area in the Showroom is plate glass, except the rear wall, which has doors into the Closing Rooms, the main Offices and Toilets.

The ceiling is acoustically treated and the floors are stained concrete marked off with an attractive design.

The Showroom is brilliantly lighted by means of large fluorescent fixtures with special spot light

effects to stress automobiles and trucks on display.

The Parts Department, is located between the Showroom and the Shop, so that it conveniently serves the Shop, the Public, and the main offices. The delivery, as can be seen on the Plan, is to the South of the building via a drive-way and thus does not conflict with circulation of traffic thru the Shop, Used Car area, Parking area, or Showroom. The Used Car Area is directly across the main entrance from the Showroom and Offices. The separation is accomplished by means of a concrete curb and iron chains on metal posts.

Because of fire hazard, the Shop is separated from the other portions of the building by means of a high masonry fire wall. This wall, incidently, lowers the insurance rates.

The design of the building is Contemporary. The wall surfaces are light plaster and the trim is aqua-blue. A broad fin projects over the Showroom windows, protecting automobiles and trucks on display from the glare of the sun. A large pylon in front together with the rear wall, supports the large sign extending over the roof. The letters are Dodge-Blue against a background of off white.

Around the show windows is a 2-foot planting strip which adds considerably to the attractiveness of the entire building and surrounding area.

The entire area not actually occupied by the new building is paved.



# A. I. A.

American Institute



# ACTIVITIES

of Architects

**Arizona Chapter:**

James Macmillan, President; Arthur T. Brown, Secretary, 740 N. Country Club Road, Tucson, Arizona.

**Central Valley of California:**

Herbert E. Goodpastor, President; Frank V. Mayo, Secretary, 307 Exchange Building, Stockton 2, California.

**Colorado Chapter:**

Raymond H. Ervin, President; James M. Hunter, Secretary, 2049 Broadway, Boulder, Colorado.

**Montana Chapter:**

Ralph H. Cushing, President; H. C. Cheever, Secretary, Montana State College, Bozeman, Montana.

**Northern California Chapter:**

Hervey P. Clark, President; Lester Hurd, Vice-President; Ralph Pollack, Secretary; William C. Ambrose, Treasurer; 605 Market Street, San Francisco.

**Oregon Chapter:**

Francis Jacobberger, President; J. D. Annand, Secretary, 401 Central Building, Portland 5, Oregon.

**San Diego Chapter (California):**

H. Louis Bodmer, President; Louis J. Gill, Secretary, 203 Granger Building, San Diego, California.

**Santa Barbara Chapter (California):**

Chester L. Carjola, President; Robert I. Hoyt, Secretary, 116 E. Sola St., Santa Barbara, California.

**CALIFORNIA COUNCIL OF ARCHITECTS**

Vincent Palmer, President; Andrew Hass, Vice-President; A. C. Martin, Jr., Secretary-Treasurer; 369 Pine St., San Francisco 4.

**Southern California Chapter:**

Adrian Wilson, President; A. C. Martin, Jr., Vice President; Walter L. Reichardt, Secretary; George E. Gable, Treasurer; Chapter Headquarters, 3757 Wilshire Blvd., Los Angeles 5, California.

**Spokane Chapter (Washington):**

Noel E. Thomson, President; Kenneth D. Storment, Secretary, Hutton Building, Spokane, Washington.

**Utah Chapter:**

George Cannon Young, President; Theodore R. Pope, Secretary, 29 South State Street, Salt Lake City 1, Utah.

**Washington State Chapter:**

Clifton J. Brady, President; Arrigo M. Young, Vice-President; John Richards, 2nd Vice-President; Ralf E. Decker, Sec.; Waldo B. Christenson, Treasurer. Office 1411 Fourth Avenue Building, Seattle 1, Washington.

**Hawaii Chapter:**

Kenneth W. Roehrig, President; James Morrison, Secretary, 334 Federal Bldg., Honolulu, T. H.

**CALIFORNIA COUNCIL OF ARCHITECTS**

Architects of California, Hawaii, Arizona, Nevada, Oregon and Washington will gather on Catalina Island, October 1, 2, 3, 4, 1947 for the Annual Convention of the California Council of Architects.

Governor Earl Warren of California, President Douglas W. Orr of the American Institute of Architects, and many other distinguished guests are expected to attend, including representatives from the Structural Engineers of California, Pacific Coast Building Officials Conference, State Builders Exchange, Associated General Contractors, Producers Council, and the Building Industry Conference Board.

Vincent Palmer, President California Council of Architects, announces the tentative program will include discussions on Hospitals, Schools, Commercial Construction and Urban Planning, with such notables as Carl Erikson and George Bugbee, Chicago; Marshall Shaffer, U. S. Public Health Service; Dr. Wilton Halverson, California State Director of Public Health; James Follin and others taking part.

"A full four day's program of 'Business' and recreation has been planned for all the Architects of California and the West, plus their wives and guests," declares Donald Beach Kirby, Convention Chairman.

**SOUTHERN CALIFORNIA CHAPTER**

The regular September meeting was devoted to the Annual Outing and Joint meeting with the Producers Council at the Uplifters Club in Santa Monica.

Aside from a general good time many tentative thoughts were given to the Annual Convention of the California Council of Architects to be held on Santa Catalina Island, October 1 to 4.

\* \* \*

CARL McELVEY, Division of Architecture and Engineering, has asked help in programming and liaison work in the University of California building program on the Los Angeles campus.

**WASHINGTON STATE CHAPTER**

The State Examination for architects' license were held in Seattle, at the University of Washington School of Architecture, September 8th to 11th.

\* \* \*

Emil Anderson, Chairman of the Education Committee, has announced the schedule of speakers obtained for students in Interior Decorating at Cornish School, under direction of Mr. Elliot. The course extends over a period of three years, going into the actual field during the last year, to work with upholstering, drapery making, paint mixing, etc.

All lectures are held on Wednesday afternoons from 4:00 to 5:00

\* \* \*

NEW CHAPTER ASSOCIATES include Arnold G. Gangnes, Clarence H. Irwin, Oliver W. Olson, and Jay Robinson, Jr.; and as JUNIOR ASSOCIATES, Eskel A. Kennedy and Otto L. Franke.

\* \* \*

COMMITTEE ANNOUNCEMENTS: The Domestic Architecture Committee now consists of Wegg,

(See Page 34)

# WITH THE ENGINEERS

Structural Engineers Association of Northern California

William W. Moore, President; John A. Blume, Vice President; Franklin P. Ulrich, Treas.; G. A. Sedgwick Sec.; Wm. H. Popert, Consultant; Office, Room 712, 57 Post St., San Francisco, Phone SUtter 1-5474. DIRECTORS, Mark Falk, M. V. Pregnoff, and R. D. Dewell.

American Society of Civil Engineers San Francisco Section

Sidney T. Harding, President; Lawrence A. Elsener, Vice President; John E. Rinne, Secretary-Treasurer, 225 Bush Street, San Francisco 20.

Puget Sound Engineering Council (Washington)

R. E. Kister, A. I. E. E., Chairman; E. R. McMillan, A. S. C. E., Vice Chairman; L. B. Cooper, A. S. M. E., Secretary; A. E. Nicherson, I. E. S., Treasurer; Offices, L. B. Cooper, c/o University of Washington, Seattle 5, Washington.

## STRUCTURAL ENGINEERS ASSOCIATION OF NORTHERN CALIFORNIA

"Structural Engineers and Public Relations" will be the theme of the four day annual Convention of the Structural Engineers of California scheduled for Yosemite Valley, October 16 to 19th.

The Structural Engineers Association of South-

ern California and the Structural Engineers Association of Northern California, together with the newly formed Structural Engineers Association of Central California are combining in presenting the three day program.

Technical papers, discussion of policy within the Association and general business matters affecting western Engineers are scheduled for the various meetings, according to an pre-convention announcement by William W. Moore, president of the state Association who will preside.

\* \* \*

The Advisory Committee of Engineering Seismology of the U.S.C. & G. Survey, comprising a membership representing 13 organizations throughout the West, met in San Francisco recently.

Henry C. Powers, represented the SEAONC, while John A. Blume represented the State SEA.

\* \* \*

H. J. BRUNNIER, has been honored as an officer of the order of the Crown of Belgium, for recognized public service. The award was made by Prince Charles at Brussels recently.

\* \* \*

JOHN H. LITTLE spoke before the Highway and Transportation Section of the Commonwealth Club of California recently on the subject: "Possible Future Bridges for San Francisco Bay and Connections for Mass Transportation thereto, in San Francisco."

\* \* \*

JOSEPH P. HAAS is now a member of the firm of HAAS and PETERSON CONSTRUCTION COMPANY, San Francisco. GEORGE J. KERKES is now with J. A. BLUME, San Francisco.

### A. S. T. E. PRESIDENT

W. B. Peirce, president of the American Society of Tool Engineers, has announced his resignation from the Flannery Bolt Company, Bridgeville, Penn., to devote full time to the A.S.T.E.

### CALIFORNIA STATE BOARD OF REGISTRATION FOR CIVIL ENGINEERS

After September 19, 1947 any person using the title "Professional Engineer," "Chemical Engineer," "Mechanical Engineer," or "Petroleum Engineer" will be required to register under provisions of an amendment to the Civil Engineers' Act passed by the recent California Legislature.

Engineers practicing in any of the four branches of professional engineering—chemical, electrical, mechanical, or petroleum—have until June 30, 1948, in which to make application for registration without a written examination. Only applicants who have had not less than six years experience in the branch of professional engineering for which they seek registration, and who can furnish evi-

# F.H.A. LOANS

TO BUY—  
REMODEL—  
REFINANCE

Long-term and low-cost F. H. A. loans are available to finance the purchase of homes already built, and to aid in the construction of new homes. Monthly payment F. H. A. loans on existing homes may be arranged for periods ranging up to 20 years. F. H. A. loans up to \$5400 on new construction may be made for as long as 25 years.

*For further information  
call at our Real Estate  
Loan Department*

## CROCKER FIRST NATIONAL BANK

SAN FRANCISCO • OAKLAND  
*California's Oldest National Bank*

*Member Federal Deposit Insurance Corporation*

dence of good character, are eligible for registration.

Under a provision of the amendment the present Civil Engineers Board is increased from three to seven members. The Governor has sixty days after the effective dates of the Act to appoint the new members, one each from the four branches of professional engineering included in the amendment.

Civil engineers, who hold a valid registration at the time the amendment becomes effective have the right, without making application, to use the title Professional Engineer. Civil engineering applicants are not eligible for registration under the so-called "grandfather clause" of the amendment. They are subject to the provisions of the law relating directly to registration of civil engineers.

Although an engineer may be registered as a Professional Engineer, he has no authority to engage in the practice of civil engineering (structural engineering included) unless he holds registration as a Civil Engineer.

A provision has been made in the new law for the registration of "Engineers-in-Training." This means that immediately after graduation from an engineering school that has been accredited by the Board (there are five in California) an engineering graduate may be registered as an engineer-in-training, and after he has had the experience he will then be eligible for registration as a professional engineer in the branch of engineering he has selected as his profession. This provision does not apply to civil engineering graduates.

Application forms for registration will not be available for three or four months, according to the Executive Secretary of the State Board of Registration for Civil Engineers.

#### ENGINEER APPOINTED

Dr. Hans Albert Einstein, well known hydraulics engineer and son of the noted theoretical physicist, has been appointed acting associate professor of engineering on the Berkeley campus of the University of California.

Born in Switzerland, he comes to the University from the U. S. Department of Agriculture Soil Conservation Service.

#### NATIONAL CONFERENCE ON INDUSTRIAL HYDRAULICS

The 3rd Annual Meeting of the National Conference on Industrial Hydraulics, will be held October 16 and 17 at Chicago, Illinois.

The conference is sponsored by the Armour Research Foundation and the Graduate School of Illinois Institute of Technology in cooperation with the Western Society of Engineers and the Chicago section of the Society of Automotive Engineers, American Society of Civil Engineers and the Amer-

(See Page 39)

## A builder is judged by his buildings



A builder has no finer advertisement nor more severe critic than his own buildings. He establishes a reputation by thinking of the future, planning and building for comfort and convenience for years to come. One way to increase the value of homes and buildings is to specify built-in telephone outlets during construction. Here's why!



#### Built-in telephone

outlets add little to building costs... much to building value.

The location of the telephone can be changed or additional telephones may be added in the future



without tearing up the flooring or running wires along baseboards.

The convenience of well placed telephone outlets will be appreciated year after year.



Call or dial local Telephone Business Office.  
Ask for Architects and Builders Service.

## The Pacific Telephone and Telegraph Co.



Chairman; Thiry, vice-chairman; Kirk, Carleton, Overturf, Bain and Chiarelli. The EXHIBITION COMMITTEE now has John Rohrer as Chairman and Barney Grevstad as vice chairman. The APPRENTICE COMMITTEE consists of John I. Mattson, Chairman; Clare Moffitt, vice chairman, and Charles T. Miller. The BULLETIN COMMITTEE is: Alden, Stanton, Pearson and Turner.

\* \* \*

MEETING IN VICTORIA, October 18-19, the Washington State Chapter, A.I.A. will be hosts to their friends and colleagues of the Oregon State and Spokane Chapters at the Empress Hotel in Victoria, B. C.

\* \* \*

TACOMA SOCIETY OF ARCHITECTS is again becoming active following a brief summer vacation, reports "Chuck" Pearson.

**NORTHERN CALIFORNIA CHAPTER**

The East Bay Chapter of the A.I.A. has been formally organized, as the outcome of a recent election held to determine whether sanction should be granted by the Northern California Chapter.

Included in action by the Board of Directors, Northern California Chapter, was a resolution which stated in part: "RESOLVED, That the Northern California Chapter of the American Institute of Architects extends its greetings and best wishes for the successful development of the new chapter to the best interests of our profession."

RALPH WYCKOFF of San Jose has been appointed representative to the California Council from the Coast Counties Chapter, a sub-chapter of the N.C.C. Other delegates in the Northern California area include Clarence Calkins, Santa Rosa; A. Lewis Koue, Alameda, and William Hemple of Palo Alto.

\* \* \*

CHARLIE POPE, has been appointed Program Committee Chairman.

\* \* \*

MEMBERSHIP CHANGES during 1947 to August 12th include: NEW CORPORATE MEMBERS of A. I. A., Ralph B. Berger, Walter C. Clifford, Thomas P. Dunlop, Albert R. Hunter, Erland Siren, Lynn R. Duckering, Francis B. Hayne, Conrad F. T. Kett, Peter Kump, Wm. B. McCormack, William Mooser, William H. Rowe, Gifford E. Sobey, Oleg N. Ivanitsky.

P. J. Herold, Thomas S. Elston, Jr., Robert R. Jones, Irving F. Brown, Wm. H. Edie, Michael Goodman, Edward W. Kress, Richard A. Morse, Robert T. Reid, Jerry A. Riddell, John C. Warnecke, Ira D. Beals, Louis H. Roth, and Francis Lai Chinn.

New ASSOCIATE MEMBERS include: Helen D. French, and Frederick M. Mann, Jr.,

**BRITISH ARCHITECT APPOINTED COLLEGE OF ENGINEERING**

Joseph Haydn Miller, Associate of the Royal Institute of British Architects, has been appointed an instructor in architecture at the California College of Engineering Sciences, Oakland, California, according to Ivan Rummel, college president.

Miller is a graduate of the University of Liverpool.

**PACIFIC COAST BUILDING OFFICIALS CONFERENCE**

The Central District of the Pacific Coast Building Officials Conference recently met in San Francisco to hear A. W. Russell discuss the building code problems.

A \$60,000 Candy Factory is being built at Lomita Park, San Mateo county California.

**No More Worry on this Job... THREE HINGES.**

VISIBLE Mark of Good Construction

**STANLEY**  
Trade Mark  
THE STANLEY WORKS, NEW BRITAIN, CONNECTICUT

REMEMBER... THREE HINGES TO A DOOR



By Elmer Grey, Architect

MY DENTIST'S ASSISTANT phoned me that her employer had a client for me who would be in my office at eleven the next morning. He came in—a tall man, roughly dressed, wearing a sombrero and carrying a roll of plans in his hand. Said they were preliminaries for a large house which he had made in Canada, that I had been recommended to him and he would like my slant on them. He would leave them with me and be in again in a few days to see what I thought of them. It didn't sound any too good.

The next morning his wife came in to tell me that her husband wanted my criticisms in writing! "Look out" I said to myself, "he wants to show them to his Canadian architect! Be careful what you say!" I felt that I should tell him exactly what I thought of the plans, but do it in a way that would not offend his Canadian architect. So I put a good deal of thought into my letter—something like five pages long of single spaced typewriting it was, and delivered it at his hotel.

A few days later he called up and asked me to come over. I supposed that he wanted to settle with me for it and debated how much to charge him. At first I thought \$50 would be right; but reflected that I had given him a lot of valuable advice and raised it to \$100. That did seem like a good deal to charge for a letter—but the amount of my fee did not come up that evening.

Two days later he phoned me to come over again, saying he was leaving. After some preliminary conversation he turned to his wife and said, "Well, I must leave Mr. Grey something now"—whereupon he pulled out his wallet and handed me a \$1,000 bill!!!

I hope I concealed by emotion! I learned afterward that he owned a string of race-horses, some gold mines, some oil wells, and "everything he touches turns to gold!"

It was a Sunday and I couldn't bank the bill. I didn't know what to do with it over night. My wife suggested putting it between the pages of a book in the bookcase, but that didn't appeal to me. On the shelf in my closet was a little pasteboard box containing a bottle of ink. I made a false bottom for it, placed the \$1,000 bill beneath it and the bottle back in place. It was all wasted effort—I didn't sleep a wink that night!

The story stretches further. He sent his Canadian architect down to Pasadena from Canada to have me show him some houses I had shown him—and he finally ended up by deciding not to build at all—he bought a house instead!



## Is Each Home You Plan a "GOOD RISK"?

Banks and other home financing institutions, experienced in home construction values, agree that a poorly wired home is not as good a "risk" as one with adequate wiring.

Homes, new or remodeled, which lack a sufficient number of circuits and convenience outlets, or which utilize wire of insufficient size, are handicapped for loan or resale purposes . . . and also fail to provide the efficient electrical service the modern family requires.

Make sure the homes you plan give your clients maximum value . . . financially and in the comforts and conveniences of electrical living . . . by specifying certified Adequate Wiring.

Your local utility office will be glad to assist, without cost or obligation in the preparation of wiring layouts.

### NORTHERN CALIFORNIA ELECTRICAL BUREAU

1355 MARKET STREET  
SAN FRANCISCO 5

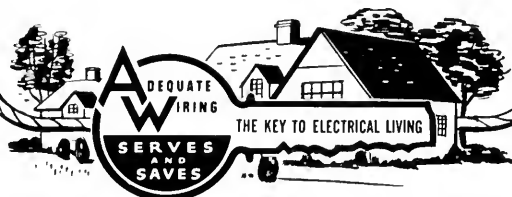

# BAXCO

CHROMATED ZINC CHLORIDE

# CZC

**PRESSURE TREATED LUMBER**  
● **PROTECTS AGAINST DECAY**  
**AND TERMITE ATTACK**

*Specify it in your home  
Available through Lumber Dealers*

LOS ANGELES  
601 W. 5th Street  
Phone Michigan 6294

SAN FRANCISCO  
333 Montgomery Street  
Phone DOuglas 2-3883

## J. H. Baxter & Co.

AGENTS FOR WEST COAST WOOD PRESERVING CO. SEATTLE, WASH.



## E. K. WOOD LUMBER CO.

**SAN FRANCISCO** General Offices: No. 1 Drumm Street

**LOS ANGELES** Office and Yards: 4710 S. Alameda St. — JE 3111

**OAKLAND** Yards and Wharves: 2111 Frederick St. — KE 24277

**PORTLAND** Mill Sales Office: 827 Terminal Sales Bldg.

**SAW MILLS:** Roseburg, Oregon • Reedsport, Oregon

**RETAIL YARDS:** LOS ANGELES • OAKLAND • ONTARIO • HOLLYWOOD

LONG BEACH • RIVERSIDE • TEMPLE CITY • SIERRA MADRE • INDIO • THERMAL

LA VERNE • WHITTIER • PASADENA • SAN PEDRO

## HEADLINE NEWS & VIEWS

By E. H. W.

A \$382-million dollar rehabilitation, repair and refurbishing program is being launched by the nation's larger hotels, according to a recent survey.

\* \* \*

The only defense against bad laws is an informed and an aroused public opinion.

\* \* \*

A recent rental advertisement in Los Angeles, offering a 5-room house on a 2-year lease at \$75 a month, resulted in 3700 replies.

\* \* \*

The national debt is \$258-billion.

\* \* \*

"The public has its fingers crossed on the real worth of present-day community planning,"—Ernest J. Kump, San Francisco Planning Consultant.

\* \* \*

Annual Fire Prevention Week has been set for October 5 to 11.

\* \* \*

"In comparison of area and population, Alameda county (California) is gaining new industries at a more rapid rate than any other Western industrial area."—Don Follet, Alameda County New Industries Committee.

\* \* \*

During the first five months of 1947 more than 300,000 new homes were completed throughout the nation. This compares with 89,000 for the same period of 1946.—National Association of Home Builders.

\* \* \*

Costs of new houses have increased 82 per cent since the 1935-39 years; Average individual income (after taxes) have risen 119 per cent, and the liquid assets of individuals is up 250 per cent over 1939.

\* \* \*

A recent "Report to Stockholders" for the year ending April 30, 1947 shows the United States Plywood Corporation's "growth has been extremely rapid—from a sales volume of 9-million dollars in 1941 to over 43-million dollars in the 1947 fiscal year."—Lawrence Ottinger, President.

\* \* \*

"On the basis of information received from our chapters throughout the country representing highway contractors, the A.G.C. brings you this recommendation: **The time has arrived to speed up the highway construction program.**"—H. E. Foreman, Managing Director, Associated General Contractors of America, Missoula, Montana.

## IN THE NEWS

### VETERANS MEMORIAL

Paul I. Jenks, Grass Valley, has been awarded a \$53,237.00 contract for remodeling the Grass Valley (California) Veteran's Memorial Building.

### RACE TRACK

A permit has been granted for the construction of a new stable at the Pacific Turf Club, Albany, California to cost \$115,000. Alterations to the race track costing \$179,000, have also been authorized. Swinerton & Walberg, San Francisco, are the general contractors. Troehlech & Mahew, Architects.

### VEST POCKET COMPASS

Circles from 2-inches to 12-feet in diameter can be made with the new vest-pocket size FLEX-A-BEAM compass, manufactured by the Stewart-Jackson Instrument Company of Los Angeles, California.

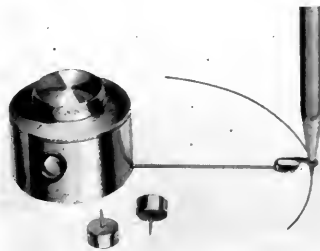

The compass consists of a stretch proof linen line on an aluminum encased reel; special push pins serve as center points, and the line will hold true to any desired length.

### HIGH SCHOOL ADDITION

A CPA permit has been granted for the construction of an agricultural classroom for the Manteca, California, Union High School to cost \$43,640.

### FACTORY BUILDING

A CPA permit has been granted and work started on a new \$50,000 factory building addition to the Kawneer Company plant in Berkeley, California.

### CHEESE FACTORY

A CPA permit has been granted for the construction of a \$75,000 cheese factory at Tulare, California. Walter Wagner, Architect, Fresno. Ralph Utter, Contractor, Tulare.

# MORE LIGHT on Outdoor Living

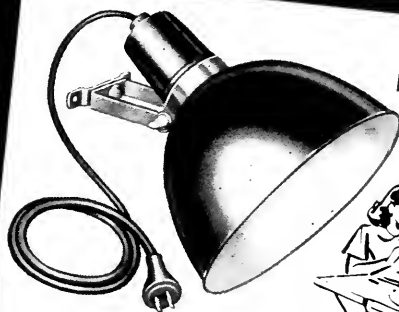

## IN THE HOME



Smoot-Holman lighting is filling ever greater needs in today's trend toward better living. Architects and home builders are planning patios and garden spots for exterior living space in every home. Smoot-Holman Outdoor Lighting Equipment doubles their usefulness by providing efficient, comfortable lighting for any desired area.



## FOR SPORTS

From croquet and back-yard badminton to tournament tennis, Smoot-Holman Outdoor Lighting provides the means to extend the usefulness of recreation areas far into evening hours. Certified Smoot-Holman lighting equipment distributes light evenly, without glare—for home, playground, office, store or factory.



Offices in  
Principal  
Western  
Cities

Branch and  
Warehouse  
in  
San Francisco

**SMOOT-HOLMAN**

INGLEWOOD, CALIFORNIA

MADE IN U.S.A.

FOR THE BEST IN INDOOR AND OUTDOOR LIGHTING IT'S SMOOT-HOLMAN

# LANDSCAPE ARCHITECTURE

## Notes of The Profession

---

ASSOCIATION OF LANDSCAPE ARCHITECTS, SAN FRANCISCO REGION

Vernon Dean, President; Robert Royston, Vice-President; Ned Rucker, Treasurer; E. L. Anderson, Corresponding Secretary, 1736 Franklin St., Oakland, California.

---

### ALBANY RACE TRACK

Low bidders on the landscape construction for the Albany (California) Race Track were Huettig & Schromm. Their bid of \$54,704 was more than \$16,000 under the next lowest.

William Penn Mott, Jr., A.L.A. is the Landscape Architect for the project.

\* \* \*

### MARIN ART & GARDEN SHOW

Many Bay Area Landscape Architects are participating in the Marin Art & Garden Show to be held in Ross, September 18 to 21. Landscape Architects are collaborating with sculptors of the Bay area to produce numerous small gardens, each featuring a piece of sculpture. Mrs. Van Pelt, who is directing the proceedings, is circularizing a prospectus, points out that this exhibit "At least could be genuine creative effort which might have true significance."

\* \* \*

### A.L.A. MEETING

At a recent A.L.A. meeting held at the Claremont Hotel in Berkeley, the membership committee reported the acceptance of 12 new members during the past year. It also reported the eligibility standards have been raised in an effort to increase the strength and quality of the profession.

\* \* \*

### FEES

The fee problem is currently being considered by a special committee. In an exhaustive study begun last fall, examinations were made of many sources pertinent to the matter of professional and office fees. A uniform guide for eventual use by A. L. A. members has been compiled, and a resume of the general report has been sent to members for their consideration and comment. The subject is extremely important and complicated and requires intensive study. The committee hopes, with a little more time to present for adoption a fair and comprehensive fee chart.

\* \* \*

### MAJOR PROJECT

The new Campbell's Soup Cannery in Sacramento (California) will be landscaped by Arthur Cobbleddick of Menlo Park. Cobbleddick's plans cover 12 acres of the 50 acre site and include a

wide lawn approach, convenient parking areas, and extensive employee recreation facilities. Building construction is being done by the Austin Company of Oakland.

---

### DAVIS FACULTY HOMES

Construction of 45 new homes for sale to University of California College of Agriculture faculty members at Davis, California, began in September.

The homes are of two and three bedroom size located on one acre lots near the entrance to the University.

---

GARDNER A. DAILY, San Francisco, has been selected as the Architect for the new \$2,000,000 Del Monte Hotel, Monterey County, California.

---

### JUVENILE HOME

Belmont, California, will be the site of a \$150,000 juvenile home to be operated by San Mateo County. Bonds have been voted. Hervey P. Clark, San Francisco, is the Architect.

---

CPA PERMIT has been granted the Memorial Baptist Church, Fresno, California, for construction of a \$30,000 Community Center Building. Donald Powers Smith, Architect, San Francisco.

---

### PLYWOOD INDUSTRY

To better offer a practical field department, the Douglas Fir Plywood Association has appointed Joe Weston to head this new department. Weston, formerly of Los Angeles, California, has been connected with design and construction of all types of plywood buildings since 1934, introducing the modular design for plywood in 1938.

His offices will be in Tacoma, Washington.

---

### PLASTIGLAZE

A new plastic coating called "Plastiglaze" has been developed by the Calresin Corp'n of Culver City, California. It is impervious to water, salt air and water, and most mild acid solutions.

---

BONDS VOTED. John I. Sasterly, Architect, announces bonds have been voted for a \$122,000 grammar school near San Jose, California.

## WITH THE ENGINEERS

(From Page 33)

ican Society of Mechanical Engineers.

Subjects under discussion will include: "Cavitation," "Industrial Application of Hydraulics," "Automotive Fluid Transmissions," and "Hydraulic Controls."

### UC EXTENSION OFFERS ENGINEERING COURSES

The University of California Extension has announced the scheduling of a number of evening courses in Engineering to be held during the fall semester in San Francisco, Oakland and Berkeley.

Open to all interested persons, the courses will begin in September and will include General Engineering, Civil Engineering, Electrical Engineering, Mechanical Engineering, and Properties of Metals.

### SOCIETY OF AUTOMOTIVE ENGINEERS

The annual Fall meeting of the Aeronautics and Aircraft Engine division of the Society of Automotive Engineers will be held in Los Angeles on October 2, 3, 4.

A comprehensive exhibit will be arranged in conjunction with the meeting.

### CALIFORNIA CIVIL SERVICE

The California State Personnel Board has announced a continuous civil service for Senior Structural Engineer. The work to consist of more difficult types of technical and supervisory structural engineering work involved in the design and in the examination in the field of major structures.

The salary will range from \$481 to \$584.

Complete information is available through California State Division of Architecture, Sacramento, California.

### THEATRE ENGINEERING CONFERENCE

The fall Semi-Annual Convention of the Society of Motion Picture Engineers will be held on October 20 to 24 at the Hotel Pennsylvania in New York, according to an announcement by Loren L. Ryder, president.

The meeting will be devoted principally to theatre design and construction, including acoustics, lighting, seating, ventilating, floor covering, decorating and display.

### THE PRODUCERS COUNCIL NORTHERN CALIFORNIA CHAPTER

"The Cavalcade of Marble" was the subject of a colored motion picture shown members recently by Louis D. Saylor of the Vermont Marble Company.

The picture portrayed the history of the vast marble beds that exist in the State of Vermont, and follows through modern mills and shops which fabricate the marble for use in a wide variety of instances.

### CONCRETE PIPE ASSOCIATION

Howard F. Peckworth, managing director of the American Concrete Pipe Association, was one of the principal speakers at the Associated Concrete Products Manufacturers meeting in Seattle on September 19.

He is also scheduled to speak at the annual convention of the California Associated Concrete Pipe Manufacturers in Bakersfield on October 23-25, on the subject "Current Affairs Effecting the Concrete Pipe Industry."

### BRICK ASSOCIATION MOVES

The Clay Brick Manufacturers' Association of Northern California have moved their general offices to the Sharon Building, 55 New Montgomery Street, San Francisco, according to a recent announcement by George E. Solnar, Jr., Manager.

YOUNGER CONSTRUCTION CO., San Francisco, have been awarded contract for construction of a \$40,000 market building at Ukiah, California.

## THE UNIVERSITY OF SYDNEY CHAIR OF TOWN AND COUNTRY PLANNING

The Senate of the University of Sydney invites applications for the Chair of Town and Country Planning which has recently been established. The tenure of the Chair will be for a period of five years; extension of tenure may be made under conditions to be determined before the expiry of that period. The Professor will be required to conduct post-graduate courses leading to a Diploma in Town and Country Planning and such other special courses in the University as may be established. He will also be required to undertake duties of an advisory character for the Department of Local Government and the Sydney Technical College and to discharge such teaching duties in addition at the Sydney Technical College as may be determined. He will be permitted to engage in consultative practice under conditions approved by the University. The salary will be at the rate of £2,000 (Australian) per annum. Applicants for the Chair are requested to send one application to the Secretary, Universities Bureau of the British Empire, 8 Park Street, London, W.1, and one copy to the undersigned not later than 30th September, 1947, in each case.

**G. DALE, REGISTRAR**  
**University of Sydney**  
**July, 1947**                      **Sydney, Australia**

## FORDERER CORNICE WORKS

Manufacturers of

Hollow Metal Products • Interior Metal Trim  
Elevator Fronts and Cabs  
Metal Plaster Accessories • Sanitary Metal Base  
Flat and Roll Metal Screens  
Metal Cabinets • Commercial Refrigerators

269 POTRERO AVE.

SAN FRANCISCO, CALIF.

HEMLOCK 4100

## STRUCTURAL STEEL

For Class A Buildings,  
Bridges, etc.

JUDSON PACIFIC - MURPHY CORP.

4300 EASTSHORE HIGHWAY  
EMERYVILLE, CALIF.

## VALUABLE NEWS SERVICE

- BUILDING MATERIAL DEALERS
- CONTRACTORS
- ENGINEERS
- FINANCIAL INSTITUTIONS

**ARCHITECTS REPORTS** gives advance news on construction projects in Northern California, lists: name of projects, location, architect, proposed cost and other pertinent information.

**HANDY** individual slip-reports, issued daily at a total cost of only

\$10 a month

## ARCHITECT'S REPORTS

Published Daily

The ARCHITECT and ENGINEER, Inc.

68 Post Street, San Francisco - DO 8311

## A LOW COST G.I. HOME

In an effort to solve the problem of rising costs in building a home, Carlton A. Steiner, A.I.A., Architect, and the Henry Arian Construction Company of San Francisco, pooled their interests in developing a new type G. I. residence, which can be built under construction industry conditions for approximately \$6500.

Two experimental low-cost units have been completed in Sausalito, a Marin county community across the Golden Gate Bridge from San Francisco, and opened to the public for inspection.

These two residences are modern in design with large glass areas for indoor-outdoor living. They have spacious kitchens equipped with an automatic dishwasher-washing machine combination and a stove and a refrigerator. The bathroom includes the latest in fixtures; there is a fireplace, and all other appointments a well constructed home should have.

The extremely low cost feature of the completed unit is based upon the principle of quantity production, and it is the opinion of both the architect and the contractor that these homes will create considerable interest among veterans as the average residence is not available under \$10,000.

Another very important feature of the initial construction is that the home is designed to grow with the family needs.

The dining area of the 30 foot long living room is separated by a removable unit wall closet and door to do duty as a temporary bedroom. The roof and electrical work for future bedrooms are in place and are utilized for a carport.

With some tinkering ability and weekend time the veteran, with guidance from the architect and contractor supplied at no cost to him, can finish floors and walls for two bedrooms at a cost of less than \$500. No structural work will be required.

Based upon a full G.I. loan monthly payments will run \$40 or less per month. Modern furnishings in keeping with the home can be financed by the lending agency without becoming a burden to the home-owner, as it is estimated the home can be furnished at a cost of \$1000.

## AGC SURVEY

A nationwide survey conducted by the Associated General Contractors of America, Inc. among local chapters in the 48 states of the nation shows the volume of commercial, industrial, and institutional construction since Federal decontrol on July 1st, to be up 30 per cent in California.

Montana shows an upswing of approximately 50 per cent; and Oregon reports an increase of 15 per cent.

# ESTIMATOR'S GUIDE

## BUILDING AND CONSTRUCTION MATERIALS

PRICES GIVEN ARE FIGURING PRICES AND ARE MADE UP FROM AVERAGE QUOTATIONS FURNISHED BY MATERIAL HOUSES TO SAN FRANCISCO CONTRACTORS. 2½% SALES TAX ON ALL MATERIALS BUT NOT LABOR

All prices and wages quoted are for San Francisco and the Bay District. There may be slight fluctuation of prices in the interior and southern part of the state. Freight cartage, at least, must be added in figuring country work.

**BONDS**—Performance—\$10 per \$1000 of contract. Labor and materials, \$10 per \$1000 of contract.

**BRICKWORK**—

- Common Brick—Per 1M laid—\$80.00 to \$100.00 (according to class of work).
- Face Brick—Per 1M laid—\$150 to \$200 (according to class of work).
- Brick Steps—\$2.30 per lin. ft.
- Brick Veneer on Frame Bldg.—Approx. \$1.50 per sq. ft.
- Common Brick—\$26.00 per M, truckload lots, f.o.b. job.
- Face Brick—\$60 to \$100 per M, truckload lots, delivered.
- Cartage—Approx. \$5.00 per M.

**BUILDING PAPER**—

- 1 ply per 1000 ft. roll..... \$5.30
- 2 ply per 1000 ft. roll..... 7.80
- 3 ply per 1000 ft. roll..... 9.70
- Brownskin, Standard, 500 ft. roll..... 7.00

**BUILDING HARDWARE**—

- Sash cord com. No. 7.....\$2.65 per 100 ft.
- Sash cord com. No. 8..... 3.00 per 100 ft.
- Sash cord spot No. 7..... 3.65 per 100 ft.
- Sash cord spot No. 8..... 4.00 per 100 ft.
- Sash weights, cast iron, \$75.00 ton.
- Nails, \$3.42 base.

**CONCRETE AGGREGATES**—

The following prices net to Contractors unless otherwise shown. Carload lots only.

	Bunker per ton	Del'd per ton
Gravel, all sizes .....	\$2.44	\$2.75
Top Sand .....	2.38	3.13
Concrete Mix .....	2.38	3.06
Crushed Rock, ¼" to ¾".....	2.38	2.94

	Bunker per ton	Del'd per ton
Crushed Rock, ¾" to 1½".....	\$2.38	\$3.13
Roofing Gravel .....	2.81	3.50
River Sand .....	2.50	3.06

**Sand**—

Lapis (Nos. 2 & 4).....	3.56	3.94
Olympia (Nos. 1 & 2).....	3.56	3.88

**Cement**—  
Common (all brands, paper sacks), carload lots, \$3.02 per bbl. f.o.b. car; delivered \$3.40.  
Cash discount on carload lots, 10c a bbl., 10th Prox., less than carload lots \$4.00 per bbl. f.o.b. warehouse or delivered.  
Cash discount 2% on L.C.L.

Atlas White	} 1 to 100 sacks, \$3.13 sack warehouse or del.; \$9.56 bbl. carload lots.
Calaveras White	
Medusa White	

**DAMP-PROOFING and Waterproofing**—

- Two-coat work, \$5.00 per square.
- Membrane waterproofing—4 layers of saturated felt, \$9.00 per square.
- Hot coating work, \$3.00 per square.
- Medusa Waterproofing, \$3.50 per lb. San Francisco Warehouse.
- Tricocel waterproofing.  
(See representative.)

**ELECTRIC WIRING**—\$15 to \$20 per outlet for conduit work (including switches).

Knob and tube average \$6.00 per outlet. (Available only for priority work.)

**ELEVATORS**—

Prices vary according to capacity, speed and type. Consult elevator companies. Average cost of installing a slow speed automatic passenger elevator in small four story apartment building, including entrance doors, about \$8000.00.

**EXCAVATION**—

Sand, \$1.00; clay or shale, \$1.50 per yard. Trucks, \$30 to \$45 per day.  
Above figures are an average without water. Steam shovel work in large quantities, less; hard material, such as rock, will run considerably more.

**FIRE ESCAPES**—

Ten-foot galvanized iron balcony, with stairs, \$250 installed on new buildings; \$300 on old buildings.

**FLOORS**—

- Composition Floors, such as Magnesite, 50c per square foot.
- Linoflor—2 gages—\$3.00 per sq. yd.
- Mastipave—\$1.50 per sq. yd.
- Battleship Linoleum—available to Army and Navy only—1/8"—\$3.50 sq. yd. 3/16"—\$3.50 sq. yd.
- Terazzo Floors—\$1.50 per sq. ft.
- Terazzo Steps—\$2.50 per lin. ft.
- Mastic Wear Coat—according to type—20c to 35c.

**Hardwood Flooring**—

- Standard Mill grades not available.
- Victory Oak—T & G
- 3/4" x 2 1/4".....\$252.00 per M. plus Cartage
- 1/2" x 2"..... \$210.00
- 1/2" x 1 1/2"..... 200.00

Refinished Standard & Better Oak Flooring  
3/4" x 3 1/4".....\$265.00 per M. plus Cartage  
1/2" x 2 1/2"..... 237.00 per M. plus Cartage

Maple Flooring  
3/4" T & G Clear \$330.00 per M. plus Ctg.  
2nd 305.00 per M. plus Ctg.  
3rd 255.00 per M. plus Ctg.  
Floor Layers' Wage, \$2.12½ per hr. (Legal as of July 1, 1947. Given us by Inlaid Floor Co.)

**GLASS**—

- Single Strength Window Glass..... \$.40 per □ ft.
- Double Strength Window Glass..... .60 per □ ft.
- Plate Glass, under 75 sq. ft..... 1.25 per □ ft.
- Polished Wire Plate Glass..... 2.10 per □ ft.
- Rgh. Wire Glass .....
- Obscure Glass .....
- Glazing of above is additional.
- Glass Blocks.....\$2.75 per □ ft. set in place

**HEATING**—

Average, \$2.50 to \$3.00 per sq. ft. of radiation, according to conditions.  
Warm air (gravity) average \$64 per register.  
Forced air average \$91 per register.

**INSULATION AND WALLBOARD**

Asph. Insulation—Full thickness (2")	\$65.00 per M sq. ft.
Cotton Insulation—Full thickness (3 1/2")	\$95.50 per M sq. ft.
Aluminum Insulation—Foil-mounted on both sides	\$33.50 per M sq. ft.
Tileboard—4'x6' panel	\$9.00 per panel
Wallboard—1/2" thickness	\$49.50 per M sq. ft.
Finished Plank	\$69.00 per M sq. ft.
Ceiling Tileboard	\$69.00 per M sq. ft.

**IRON**—Cost of ornamental iron, cast iron, etc., depends on designs.

**LUMBER**—

No. 1 Common	\$90.00 per M
No. 2 Common	88.00 per M
Select O. P. Common	94.00 per M
<b>Flooring</b> —	
	Per M Delvd.
V.G.—D.F. B & Btr. 1 x 4 T & G Flooring	\$170.00
"C" and better—all	170.00
"D" and better—all	170.00
Rwd. Rustic—"A" grade, medium dry	150.00
B to 24 ft.	
"B" grade, medium dry	150.00
<b>Plywood</b> —	
	15c to 18c per ft.
Plyscord	9/2c per ft.
Plywall	9c per ft.
Plyform	15c per ft.
<b>Shingles (Rwd. not available)</b> —	
Red Cedar No. 1	\$13.00 per square; No. 2, \$10.50; No. 3, \$9.00.
Average cost to lay shingles	\$6.00 per square.
Cedar Shakes—Tapered: 1/2" to 3/4" x 25"	\$17.00 per square.
Resawn: 3/4" to 1 1/4" x 25"	\$22.00 per square
Average cost to lay shakes	8.00 per square

**MILLWORK**—Standard.

D. F. \$150 per 1000. R. W. Rustic \$175 per 1000 (delivered).  
 Double hung box window frames, average with trim, \$12.50 and up, each.  
 Complete door unit, \$15 to \$25.  
 Screen doors, \$6.00 to \$8.00 each.  
 Patent screen windows, \$1.25 a sq. ft.  
 Cases for kitchen pantries seven ft. high, per lineal ft., \$12.00 each.  
 Dining room cases, \$15.00 per lineal foot. Rough and finish about \$1.00 per sq. ft.  
 Labor—Rough carpentry, warehouse heavy framing (average), \$60.00 per M.  
 For smaller work average, \$60.00 to \$75.00 per 1000.

**MARBLE**—(See Dealers)

**PAINTING**—

Two-coat work .....per yard 60c  
 Three-coat work .....per yard 80c  
 Cold water painting .....per yard 25c  
 Whitewashing .....per yard 15c  
 Turpentine..... \$1.85 per gal. in 5-gal. cont.  
 Raw Linseed Oil.....\$3.33 per gal. in 5-gal. cont.

Boiled Linseed Oil ..... \$3.23 per gal. in drums.  
 Boiled Linseed Oil—\$3.33 per gal. in 5-gal. containers.  
 Replacement Oil—\$2.75 per gal. in drums. \$2.75 per gal. in 5-gal. containers.  
 Use Replacement Oil.....\$3.00 per gal. in 1 gal. cont.  
 A deposit of \$7.50 required on all drums.

**PATENT CHIMNEYS**—

6-inch	\$2.00 lineal foot
8-inch	2.50 lineal foot
10-inch	3.50 lineal foot
12-inch	4.50 lineal foot

**PLASTER**—

Neat wall, per ton delivered in S. F. in paper bags, \$17.60.

**PLASTERING (Interior)**—

3 Coats, metal lath and plaster	Yard \$3.00
Keene cement on metal lath	3.50
Ceilings with 3/4 hot roll channels metal lath (lathed only)	3.00
Ceilings with 3/4 hot roll channels metal lath plastered	4.50
Single partition 3/4 channel lath 1 side (lath only)	3.00
Single partition 3/4 channel lath 2 inches thick plastered	8.00
4-inch double partition 3/4 channel lath 2 sides (lath only)	5.75
4-inch double partition 3/4 channel lath 2 sides plastered	8.75
Thermax single partition; 1" channels; 2 1/4" overall partition width. Plastered both sides	7.50
Thermax double partition; 1" channels; 4 3/4" overall partition width. Plastered both sides	11.00
3 Coats over 1" Thermax nailed to one side wood studs or joists	4.50
3 Coats over 1" Thermax suspended to one side wood studs with spring sound isolation clip	5.00
Note—Channel lath controlled by limitation orders.	

**PLASTERING (Exterior)**—

2 coats cement finish, brick or concrete wall	Yard \$2.50
3 coats cement finish, No. 18 gauge wire mesh	3.50
Lime—\$4.00 per bbl. at yard.	
Processed LLime—\$4.15 per bbl. at yard.	
Rock or Grip Lath—3/8"—30c per sq. yd. 3/4"—29c per sq. yd.	
Composition Stucco—\$4.00 sq. yard (applied).	

**PLUMBING**—

From \$150.00 per fixture up, according to grade, quality and runs.

**ROOFING**—

"Standard" tar and gravel, 4 ply—\$11.00 per sq. for 30 sqs. or over.  
 Less than 30 sqs. \$14.00 per sq.  
 Tile \$40.00 to \$50.00 per square.  
 Redwood Shingles, \$15.00 per square in place.  
 5/2 # 1-16" Cedar Shingles, 4 1/2" Exposure .....\$16.50 square

5/8 x 16"—#1 Cedar Shingles, 5" Exposure .....\$17.00 square  
 4/2 # 1-24" Royal Shingles, 7 1/2" Exposure .....\$18.25 square  
 Re-coat with Gravel \$5.50 per sq.  
 Asbestos Shingles \$30 to \$60 per sq. laid.  
 1/2 x 25" Resawn Cedar Shakes, 10" Exposure .....\$18.50  
 3/4 x 25" Resawn Cedar Shakes, 10" Exposure ..... 21.00  
 1 x 25" Resawn Cedar Shakes, 10" Exposure ..... 22.00  
 Above prices are for shakes in place.

**SHEET METAL**—

Windows—Metal, \$2.50 a sq. ft.  
 Fire doors (average), including hardware \$2.80 per sq. ft.

**SKYLIGHTS**—(not glazed)

Copper, \$1.25 sq. ft. (flat).  
 Galvanized iron, 65c sq. ft. (flat).  
 Vented hip skylights 90c sq. ft.

**STEEL—STRUCTURAL**—

\$220 per ton erected, when out of mill.  
 \$270 per ton erected, when out of stock.

**STEEL REINFORCING**—

\$150 to \$170 per ton, in place.

**STORE FRONTS** (None available).

**TILE**—

Ceramic Tile Floors—\$1.50 per sq. ft.  
 Cove Base—\$1.25 per lin. ft.  
 Glazed Tile Wainscot—\$1.50 per sq. ft.  
 Asphalt Tile Floor 1/8" x 3/8"—\$.40 per sq. ft. Light shades slightly higher.  
 Cork Tile—\$1.00 per sq. ft.  
 Mosaic Floors—See dealers.  
 Lino-Tile—\$1.00 per sq. ft.

**Wall Tile**—

Glazed Terra Cotta Wall Units (single faced) laid in place—approximate prices:  
 2 x 6 x 12.....\$1.25 sq. ft.  
 4 x 6 x 12..... 1.50 sq. ft.  
 2 x 8 x 16..... 1.45 sq. ft.  
 4 x 8 x 16..... 1.75 sq. ft.

**VENETIAN BLINDS**—

75c per square foot and up. Installation extra.

**WINDOWS—STEEL**—

50c per square foot, \$5 for ventilators.



# IN THE NEWS

## KING CITY SCHOOL

Five classrooms and a shop building costing \$144,170 will be added to the King City (California) Elementary School, according to a recent CPA permit. Chas. E. Butler, Architect, Salinas.

## JEWELRY STORE REMODEL

Roselyn & Gartner, Architects, San Francisco, report that Jacks & Irvine, general contractors, have been awarded contract for remodeling of the Albert F. Samuels jewelry store in San Francisco. Cost \$100,000.

## PROJECTED STEEL SASH

The new COPCO COMMERCIAL PROJECTED STEEL SASH with ventilators that swing out from the bottom and slide down from the top, is available in six sizes.

Easy action side arms allow the ventilator to be opened to any angle up to 75 degrees.

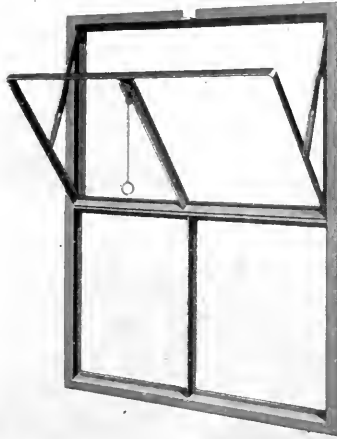

No projections extend into the building to interfere with free movement near the window.

When installed in tandem a strong mullion, three inches wide,

provides anchorage without cutting down the amount of light. Manufactured by Copco Steel and Engineering Company, 14035 Grand River Ave., Detroit 27, Michigan.

## T B HOSPITAL

A CPA permit has been granted for construction of a 105-bed Tuberculosis Infirmary Building at Springville (California) to cost \$411,192. W. D. Coates, Architect, Fresno.

## COLLEGE OF LAW

The California State Legislature recently approved an expenditure of \$1,450,000 for the construction of a new Hastings College of Law in San Francisco. Site not yet selected.

## BANK ADDITION

The Citizens Bank of Sacramento (California) has been granted a permit for remodeling their building. Harry J. Devine, Architect, and A. E. Erickson & Sons, general contractor, both of Sacramento.

## BUILDING TRADES WAGE (JOB SITES) NORTHERN AND CENTRAL CALIFORNIA

ATTENTION: The following are the PREVAILING hourly rates of compensation as determined by the Wage Adjustment Board, or which have been determined by the United States Department of Labor—Revised to July 1, 1946. Wage scales shown are those being paid and in effect mostly by agreement between employees and their union.

CRAFT	San Francisco	Alameda and Contra Costa		Marin	Vallejo	San Mateo	San Jose	Stockton	Sacramento	Fresno
ASBESTOS WORKERS	1.75	1.75	1.75	1.75	1.75	1.75	1.75	1.75	1.75	1.75
BRICKLAYERS	2.05	2.05	2.05	2.05	2.05	2.05	2.05	1.75	2.05	2.00
BRICKLAYERS, HODCARRIERS	1.57½	1.57½	1.57½	1.57½	1.57½	1.57½	1.57½	1.47½	1.15	1.25
CARPENTERS	1.75	1.75	1.75	1.75	1.75	1.75	1.62½	1.50	1.50	1.50
CEMENT FINISHERS	1.75	1.75	1.75	1.75	1.75	1.75	1.75	1.75	1.75	1.75
ELECTRICIANS	1.87½	1.87½	1.87½	1.70	1.87½	1.87½	1.87½	1.75	1.82½	1.75
ENGINEERS: MATERIAL HOIST	1.60	1.60	1.60	1.60	1.60	1.60	1.60	1.60	1.60	1.60
PILE DRIVER	2.00	2.00	2.00	2.00	2.00	2.00	2.00	2.00	2.00	2.00
STRUCTURAL STEEL	2.00	2.00	2.00	2.00	2.00	2.00	2.00	2.00	2.00	2.00
GLASS WORKERS	1.58½	1.58½	1.58½	1.58½	1.58½	1.58½	1.21	1.40	1.37½	1.37½
IRONWORKERS: ORNAMENTAL	1.85	1.85	1.85	1.85	1.85	1.85	1.85	1.85	1.85	1.85
REINF. RODMEN	1.75	1.75	1.75	1.75	1.75	1.75	1.75	1.75	1.75	1.75
STRUCTURAL	2.00	2.00	2.00	2.00	2.00	2.00	2.00	2.00	2.00	2.00
LABORERS: BUILDING & CONCRETE	1.25	1.25	1.15	1.15	1.15	1.15	1.15	1.25	1.25	1.15
LATHERS	1.90	1.90	1.60	1.87½	1.75	2.00	1.87½	1.60	1.87½	1.60
MARBLE SETTERS	1.75	1.75	1.75	1.75	1.75	1.75	1.75	1.75	1.75	1.75
MOSAIC & TERRAZZO	1.75	1.75	1.75	1.75	1.75	1.75	1.75	1.60	1.60	1.12½
PAINTERS	1.75	1.75	1.75	1.64	1.75	1.75	1.75	1.60	1.60	1.50
PILEDRIVERS	1.86	1.86	1.86	1.86	1.86	1.86	1.86	1.86	1.86	1.86
PLASTERERS	2.00	2.00	1.75	2.00	2.05	2.00	2.00	1.87½	1.87½	1.87½
PLASTERERS' HODCARRIERS	1.75	1.75	1.75	1.75	1.75	1.75	1.75	1.65	1.65	1.40
PLUMBERS	1.87½	1.87½	1.87½	1.87½	1.87½	1.87½	1.87½	1.87½	1.87½	1.87½
ROOFERS	1.50	1.62½	1.50	1.62½	1.25	1.37½	1.50	1.50	1.50	1.50
SHEET METAL WORKERS	1.75	1.75	1.75	1.75	1.75	1.75	1.75	1.75	1.75	1.75
SPRINKLER FITTERS	1.58	1.58	1.58	1.58	1.58	1.58	1.58	1.58	1.58	1.58
STEAMFITTERS	1.87½	1.87½	1.87½	1.87½	1.87½	1.87½	1.87½	1.87½	1.87½	1.87½
STONESETTERS (MASONS)	2.05	2.05	2.05	2.05	2.05	2.05	2.05	1.75	2.05	2.00
TILESETTERS	1.80	1.75	1.75	1.75	1.75	1.75	1.75	1.37½	1.37½	1.37½

Prepared and compiled by

CENTRAL CALIFORNIA CHAPTER, ASSOCIATED GENERAL CONTRACTORS OF AMERICA

with the assistance and cooperation of secretaries of General Contractors Associations and Builders Exchanges of Northern California

# CLASSIFIED ADVERTISING

RATE: 10c PER WORD . . . CASH WITH ORDER

MINIMUM \$2.50

**ARCHITECT'S REPORTS**—A valuable advance news service giving building and construction information daily on projects in Northern California. Name, location, architect, proposed cost, etc., on individual slips. Ideal for securing new business leads. Hundreds of items, total monthly cost only \$10. Don't delay, subscribe today. ARCHITECT & ENGINEER, Room 618, 68 Post Street, San Francisco, California. Phone DOUGLAS 2-8311.

**PHOTOGRAPHS:** Specializing in building and construction photographs for publication, or historic records. For Industrial-Aerial Publicity photography use the INDUSTRIAL PHOTO'S, Room 722, Hearst Bldg., San Francisco, Phone SUtter 1-6953.

**METAL WINDOWS** (Steel-Aluminum-Bronze). Large Stock, ALL TYPES. STEEL SASH SALES & SERVICE, Weehawken, N. J.

**ENGRAVING**—Good engravings are essential to a satisfactory job of printing reproduction. For the best, see Poor Richard Photo Engraving Co., 324 Commercial St., San Francisco.

# SISALKRAFT

REG. U. S. PAT. OFF.

*"More than a building paper"*

## THE SISALKRAFT CO.

205 West Wacker Drive  
Chicago, Ill.

55 New Montgomery Street  
San Francisco, Calif.

## CLINTON CONSTRUCTION CO. OF CALIFORNIA

**General Contractors**

923 FOLSOM STREET • SAN FRANCISCO  
SUtter 1-3440

## HOGAN LUMBER CO.

*Wholesale and Retail*

### LUMBER

MILL WORK • SASH & DOORS

*Office, Mill, Yard and Docks*  
SECOND AND ALICE STREETS • OAKLAND, CALIF.  
Telephone GLencourt 1-6861

## SANTA MARIA INN SANTA MARIA, CALIFORNIA

FRANK J. McCOY, General Manager

FERNAND E. PIMENTEL, Manager

On the  
Coast  
Highway  
between  
San  
Francisco  
and  
Los  
Angeles



American  
or  
European  
Plan  
•  
Old  
English  
Tap  
Room



### NEW FACTORY

The Fiat Metal Manufacturing Company have opened their new factory in Los Angeles which is equipped with modern machinery for the complete manufacture of shower cabinets, shower doors and receptors.



Willard C. Thompson

Willard C. Thompson, well known in the plumbing industry has been named manager of this new unit. "The erection of this new building with its facilities for manufacturing, clearly indicates our confidence in the future of the Western States. The splendid support given our company by the plumbing industries in this section was largely responsible for the creation of this new manufacturing facility which we sincerely hope will render to the industry the service and quality products that they most certainly are entitled to," company officials declared.

### ARCHITECT

Our attention has been called to the fact that Mr. Edward T. Foulkes, Architect, of Oakland, California, was the Architect on the original Andrew Williams Store in Oakland.

During the period when Williams was developing his group of super markets, Architect Foulkes worked very closely with him in the design and arrangement of the various properties.

SUPER DRIVE-IN-MARKET costing \$350,000 will be built in Sacramento, California by Luckystores, Inc., Francis A. Constable, Architect.

ARCHITECT AND ENGINEER

# BOOK REVIEWS

## PAMPHLETS AND CATALOGUES

**FACTORY LOCATION IN CALIFORNIA.** A Guide to Sources and Services. By California State Chamber of Commerce, San Francisco.

Designed to serve manufacturers seeking factory location sites in California. Includes data on industrial sites, labor costs and supply, living conditions and costs, market and distribution facilities, raw materials, power, fuel and water supply, transportation, tax and license laws, community industrial surveys, and general economic surveys. Copies free, write Research Department.

**SUPERIOR VOLTAGE CONTROL.** The Superior Electric Co., Bristol, Conn.

A fully illustrated 12-page Bulletin 547 on voltage control has just been published by the SUPERIOR ELECTRIC CO, Bristol, Conn. It features latest developments in Powerstat variable transformers and Stabiline automatic voltage regulators; ratings, detail drawings, photo's, performance and engineering data. Free upon request.

**ENGINEERING PROPERTIES and APPLICATIONS OF NI-RESIST.** The International Nickel Company, Inc., New York City, N. Y.

A 36-page well illustrated booklet giving detailed information on the physical and mechanical properties of cast nickel alloy, as well as performance under a wide variety of industrial conditions involving corrosion, heat and water. Completely indexed. Copies from publisher.

**SIMPLIFIED ENGINEERING for ARCHITECTS and BUILDERS.** 2nd Edition. By Harry Parker. \$3.00. John Wiley & Sons, Inc., New York 16, N. Y. Publishers.

Was first published in 1939 as Parkers "Simplified Engineering" and achieved wide recognition as a valuable reference for engineers, architects, contractors and students requiring quick and easy access to important terms and basis principles employed in the design of structural members in building construction. Contains valuable material on mechanics of metals, timber, steel and reinforced concrete construction and design of roof trusses. Changes in building code requirements, new tables, problems revised, and many other important features have been added to the new addition.

**SHOWROOM AND WAREHOUSE**

Earl W. Heple, San Jose, has been awarded a general contract for the construction of a \$123,093 office, showroom and warehouse in San Jose for the Tay-Holbrook, Inc. firm of San Francisco.

The Most Complete Line of  
**STEELS and BUILDING MATERIALS**  
Made by a Single Producer



See Sweet's Catalog File or write us for full information.

**REPUBLIC STEEL CORPORATION**

GENERAL OFFICES: CLEVELAND, OHIO

DENVER, COLORADO . . . . . CONTINENTAL OIL BUILDING  
LOS ANGELES, CALIFORNIA . . . . . EDISON BUILDING  
SALT LAKE CITY, UTAH . . . . . WALKER BANK BUILDING  
SAN FRANCISCO, CALIFORNIA . . . . . RIALTO BUILDING  
SEATTLE, WASH. . . . . WHITE-HENRY-STUART BUILDING

## PACIFIC MANUFACTURING CO.

HIGH CLASS INTERIOR FINISH  
QUALITY MILLWORK

142 SANSOME ST., SAN FRANCISCO  
GARfield 1-7755

6820 MCKINLEY AVE., LOS ANGELES  
THornwall 4196

BUILDERS EXCHANGE, OAKLAND

## "AMERICAN - MARSH"

CONDENSATION UNIT

Pumping  
Machinery  
for  
Every  
Purpose

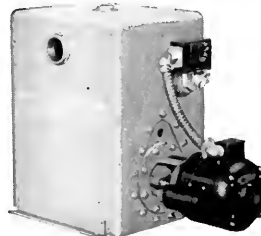

For Service  
Call  
DOuglas  
2-6794  
or  
MUtual 8322

**SIMONDS MACHINERY CO.**

SAN FRANCISCO  
816 FOLSOM

LOS ANGELES  
455 EAST 4TH

## VERMONT MARBLE COMPANY

Producers and Finishers  
of  
Domestic and Imported Marbles

525 MARKET STREET, SAN FRANCISCO  
Phone SUTter 1-6747

3522 COUNCIL STREET  
(Beverly Blvd. at Virgil Ave.)

LOS ANGELES 4, CALIF.  
Telephone FAirfax 7834





**DINING ROOM: Unusual ceiling design featuring tube lighting on top of beams. Dance floor is in center, and copper planting boxes, natural stone, wood and leather fixtures contribute to the relaxing western atmosphere.**

natural stone, wood and leather fixtures and accessories. The dance floor is of parquet hardwood flooring. To further the relaxing western air, the bar is recessed from the main dining room separated by a wood grille. A plate glass wall of the dining room overlooks the swimming pool.

A wood sun visor extends the length of the glass wall, breaking glare and reflection of light.

The charcoal broiler and service counter at the end of the dining room is of particular interest. The counter is of stainless steel. A copper hood over the broiler and rotisserie is set in brick. This section

is featured as an integral part of the dining room in plain sight of the diners. The entire section is air conditioned.

The view of the bar shows the wood baluster screen separating but not isolating the dining room from the bar. Natural stone walls and asphalt tile floor are used. Indirect light and copper trim on bar and stools are featured. The liquor display is separated from the bar proper by removable screens for night lock up. An attractive planting box lends its mellowing influence while separating the main bar from the dining room service bar.

The opposite end of display and storage space has another service bar for the cocktail lounge adjoining.

Clearly shown in the view from the swimming pool court toward the main dining room are the plate glass wall of the dining room, the wood sun visor, water tower and windmill and the natural stone wall and buttresses.

"There's still life in the old gray mare."

**DON'T** throw away those used paint brushes

## **CABOT'S BRUSH CLEANER**

*Positively removes old paint right down to the heel*

**GUNN CARLE & CO**  
20 POTRERO AVENUE • SAN FRANCISCO, CALIF.

## IN THE NEWS

### CAMP STONEMAN

A general contract has been awarded the M & K Corp'n, San Francisco, for the construction of 9-apartment buildings at Camp Stoneman, Pittsburg, California.

### MAUSOLEUM ADDITION

Henry A. Minton & Wilton Smith, Architects, San Francisco, announce a contract has been awarded Moore & Roberts for construction of 1400 Crypts in a \$300,000

addition to the St. Joseph's Cemetery Mausoleum in San Pablo, California.

### ARCHITECT SELECTED

E. Goeffrey Bangs, San Francisco architect, has been selected to design the new \$250,000 Juvenile Hall Building in Martinez, California.

### NEW Y-TYPE STRAINER

A new streamlined y-type strainer for steam, air, gas, oil or water has been announced by the WRIGHT-AUSTIN CO, 315 W. Woodbridge Street, Detroit, Mich.

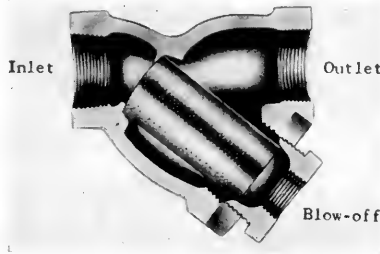

It overcomes back pressure thru a new arrangement of interior surfaces, guiding liquids or gases on a course unobstructed by sharp corners or abrupt changes in path of flow. Strainers are self cleaning, by use of blow-off cock. Suitable for steam pressures up to 50 psi. and temperatures up to 450 degrees F.

### NEW FIRE HOUSES

North Sacramento will construct a new fire house and police station, while Fresno has been granted a CPA permit for a new \$175,000 fire house.

### BOYS CLUB HOUSE

A CPA permit has been granted for the construction of a Boys Club House at Pittsburg, California, at an estimated cost of \$73,980. An initial bid offering was rejected.

### BLEACHERS

A CPA permit has been granted the Vallejo Unified School District for construction of \$67,800 worth of bleachers at the Junior College and High School, Vallejo, California.

### PETALUMA GYMNASIUM

The Petaluma Board of Education have awarded a \$75,373 contract to the Vogensen Construction Company, Petaluma, for the construction of additions to the Junior High School auditorium.



## HERRICK IRON WORKS

STRUCTURAL STEEL  
REINFORCING STEEL

18TH AND CAMPBELL STS.  
OAKLAND, CALIF.  
Phone GLencourt 1-1767

## MULLEN MFG. COMPANY

BANK, STORE AND OFFICE  
FIXTURES—CABINET WORK  
OF GUARANTEED QUALITY  
CHURCH SEATING

Office and Factory  
60-80 RAUSCH ST., Bet. 7th and 8th Sts.  
San Francisco  
Telephone UNDERhill 1-5815

## THE TORMEY COMPANY

GENERAL PAINTERS  
AND DECORATORS

Phone UNDERhill 1-1913

563 FULTON STREET  
San Francisco

Phone GARfield 1-1164

## Thomas B. Hunter

DESIGNER OF HEATING

AIR CONDITIONING  
VENTILATING AND WIRING  
SYSTEMS, MECHANICAL  
AND ELECTRICAL EQUIP-  
MENT OF BUILDINGS

★  
41 SUTTER STREET  
ROOM 710  
San Francisco California

## Scott Company

HEATING - - PLUMBING - - TILE

★  
243 MINNA STREET  
SAN FRANCISCO  
Phone EXbrook 2-6741

## DINWIDDIE CONSTRUCTION COMPANY

•  
BUILDERS  
•

CROCKER BUILDING  
SAN FRANCISCO

*Fine*  
**ENGRAVINGS**

**POOR  
RICHARD**  
PHOTO ENGRAVING CO.  
320-324 COMMERCIAL STREET  
SAN FRANCISCO 11

## A. F. MATTOCK CO.

Builders



212 CLARA STREET  
SAN FRANCISCO

## INDEPENDENT IRON WORKS

Steel Buildings  
Service Stations  
Steel Storage Tanks  
Fabricated Plate Work  
Steel & Sheet Metal Products  
Fabricated Structural Steel  
Steel Distributors

Eighth & Pine Sts. Oakland, 7

## George F. Brayer ELECTRICAL CONTRACTOR

166 Seventh Street  
San Francisco

Phone: Market 1-1761

## PITTSBURGH TESTING LABORATORY

Successors to  
SMITH, EMERY & COMPANY

Testing and Inspecting  
Engineers and Chemists

Structural Materials, Structures  
Equipment, Pipe, Soils.

651 Howard St., San Francisco 5  
EXbrook 2-1747

## Index to Advertisers

ALADDIN Heating Corp.	48
ANGIER Pacific Corp.	*
ARCHITECTS Reports	40
BASALT Rock Company	Back Cover
BAXTER & Company, J. H.	36
BRAYER, Geo. F.	48
CLASSIFIED Advertising	43
CLINTON Construction Company	44
CROCKER First National Bank	42
DETROIT Steel Products Co.	7
DINWIDDIE Construction Co.	47
FORDEKER Cornice Works	40
FULLER, W. P. Co.	8
GORDON & Gotch, Ltd.	39
GUNN, Carle & Company	46
HANKS, Inc., Abbott A.	48
HAWS Drinking Faucet Company	5
HERRICK Iron Works	47
HOGAN Lumber Company	44
HUNT, Robert W., Company	48
HUNTER, Thos. B.	47
INDEPENDENT Iron Works	48
JUDSON, Pacific-Murphy Corp.	40
MATTOCK, A. F.	48
MICHEL & Pfeffer Iron Works	Inside Back Cover
MULLEN Mfg. Co.	47
MUELLER Brass Co.	2
NORTHERN California Electrical Bureau	35
PACIFIC Coast Aggregates, Inc.	*
PACIFIC Coast Gas Association	*
PACIFIC Manufacturing Company	45
PACIFIC Portland Cement Company	9
PACIFIC Telephone & Telegraph Co.	33
PITTSBURGH Testing Laboratory	48
POOR RICHARD Engraving	47
REMILLARD-Dandini Co.	48
REPUBLIC Steel Corporation	45
SANTA Maria Inn	44
SCOTT Co.	47
SIMONDS Machinery Company	45
SIMPSON Logging Co.	6
SISALKRAFT Company	44
SMOOT-Holman Co.	37
STANLEY Works, The	34
TAYLOR Co., Halsey W.	*
TORMEY Company, The	47
U. S. BONDS	1
VERMONT Marble Company	45
WESTERN Asbestos Company	Inside Front Cover
WESIX Company	*
WOOD, E. K., Lumber Company	36

\*Indicates Alternate Months

## Robert W. Hunt Company

ENGINEERS

Inspection - Tests - Consultation

Schools and Other Structures  
Are Built as Designed

When Construction Materials are  
Inspected at point of Manufacture  
and during Erection by

ROBERT W. HUNT COMPANY  
Cement, Concrete, Chemical, Metallurgical,  
X-Ray and Physical Laboratories

Chicago - New York - Pittsburgh  
Los Angeles - All Large Cities  
San Francisco, 251 Kearny Street

## REMILLARD-DANDINI Co.

Brick and  
Masonry Products



400 MONTGOMERY STREET  
SAN FRANCISCO, CALIF.

## A L A D D I N Heating Corp.

Specializing in  
QUALITY HEATING  
EQUIPMENT

2222 San Pablo Avenue  
OAKLAND  
TWinoaks 3-1022

## ABBOT A. HANKS, INC. Engineers & Chemists

INSPECTING - TESTING - CONSULTING  
CONCRETE • STEEL • MATERIALS  
CHEMICAL AND TESTING  
LABORATORIES

• RESEARCH AND INVESTIGATION •

TESTS OF STRUCTURAL MATERIALS  
DESIGN OF CONCRETE MIXES  
SHOP AND ERECTION INSPECTION OF  
STRUCTURES AND EQUIPMENT  
INVESTIGATION OF STRUCTURES  
AND MATERIALS  
TESTS AND INVESTIGATION OF  
FOUNDATION SOILS  
FIRE RESISTANCE AND INSULATION  
TESTS

624 Sacramento Street, San Francisco

# ARCHITECT AND ENGINEER

REXALL SQUARE, LOS ANGELES



REXALL  
DRUG  
COMPANY

OCTOBER

1947



"There's nothing more MODERN than a **GAS**-equipped kitchen"

**\*Any ARCHITECT or BUILDER can make that statement, backed by OVERWHELMING EVIDENCE**

—the beauty of line, the exclusive advantages of today's fully automatic gas ranges . . . with self-lighting burners, "high-low" flame-flexibility, clock control, oven heat control, "cool-kitchen" insulation and countless other features . . . all dear to the heart of today's "kitchen-conscious" homemaker.

—the attractive design, trouble-free long life and *silent* operation of the new gas refrigerator, (*no moving parts* in the freezing system) with its huge frozen food compartment and galaxy of other advantages

—the recognized superiority of the automatic gas water heater, always dependable and economical.

*The West Prefers*  
**GAS** 

QUICK • CLEAN • DEPENDABLE • FLEXIBLE • ECONOMICAL

Design your kitchens around these new-day *gas* appliances, with thought for step-saving, "assembly-line" food preparation . . . and you'll bank dividends of good will to draw upon in the form of *more* jobs, *new* clients!

THE PACIFIC COAST GAS ASSOCIATION



# ARCHITECT

Vol. 171

No. 1

# AND ENGINEER

ARCHITECTS' REPORTS—Published Daily

Telephone DOuglas 2-8311

## Contents for

# OCTOBER

E. H. WILDER

Editor

MARK DANIELS, A.I.A.

Associate Editor

PROF. LELAND VAUGHAN

Landscape Architecture

MICHAEL GOODMAN

Planning

JOHN S. BOLLES, A.I.A.

Book Reviews



### COVER PICTURE:

LOOMING OUT OF THE DARK-  
NESS of a Hollywood night, is the  
Rexall Drug Company's new world  
headquarters at Los Angeles, Califor-  
nia.

EDITORIAL NOTES . . . . .	4
NEWS & COMMENT ON ART . . . . .	9
LANDSCAPE ARCHITECTURE . . . . .	10
Ned S. Rucker, Landscape Architect	
FOX TILE COMPANY, New Plant . . . . .	12
Irwin M. Johnson, Architect	
AMENDMENTS TO THE CALIFORNIA STATE HOUSING ACT NOW IN EFFECT . . . . .	14
A CONTEMPORARY STORE IN CHINATOWN, SAN FRANCISCO . . . . .	15
William W. Wolf, A.I.A., Architect	
PERFORMANCE STANDARDS ESTABLISHED . . . . .	18
Fir Plywood Industry	
WORLD HEADQUARTERS OFFICE BUILDING, REXALL DRUG COMPANY, LOS ANGELES . . . . .	19
By Albert F. Roller, A.I.A., Architect	
A. I. A. ACTIVITIES . . . . .	31
WITH THE ENGINEERS . . . . .	32
IN THE NEWS . . . . .	33, 37, 43, 46, 47
HEADLINE NEWS & VIEWS . . . . .	36
By E. H. W. News of the Profession	
LANDSCAPE ARCHITECTURE . . . . .	38
COMEDY IN PROFESSIONAL PRACTICE . . . . .	39
By Elmer Grey, Architect	
ESTIMATOR'S GUIDE . . . . .	41
Building and Construction Materials	
BUILDING TRADES WAGE SCALES . . . . .	43
Northern and Central California	
CLASSIFIED ADVERTISING . . . . .	43
BOOK REVIEWS, Pamphlets and Catalogues . . . . .	45
INDEX TO ADVERTISERS . . . . .	48

ARCHITECT AND ENGINEER (Established 1905) is published on the 15th of the month by The Architect and Engineer, Inc., 68 Post St., San Francisco 4; Telephone EXbrook 2-7182. President, K. P. Kierulff; Vice-President and Manager, L. B. Penhorwood; Treasurer, E. N. Kierulff.

Los Angeles Office: Wentworth F. Green, 6605 Hollywood Blvd., Los Angeles 28, Telephone HEMPstead 3171.

Entered as second class matter, November 2, 1905, at the Post Office in San Francisco, California, under the Act of March 3, 1879. Subscriptions United States and Pan America, \$3.00 a year; \$5.00 two years; foreign countries \$5.00 a year; single copy 50c. ARCHITECTS' REPORTS are published daily from this office, Vernon S. Yallop, Manager.



WASHINGTON, D. C.

## DE LUXE TRAINS

Our attention has been called to "THE AMERICAN HERITAGE PROGRAM" which is "A plan to raise the level of active citizenship in our country" and is sponsored by a board of trustees which reads like a Who's Who of American industry, banking and education.

The program proposes a national tour of a "FREEDOM TRAIN," now being constructed as a National Shrine to house about 100 original documents of American history upon which the development of American democracy and civil rights is based.

The "FREEDOM TRAIN" is to visit each of the 48 states, coupled with special local "days," and in general function as a "revival meeting" for American democracy.

The "AMERICAN HERITAGE PROGRAM" and its "FREEDOM TRAIN" has already run into an open switch, thrown by political opportunists who see in the project an opportunity to convert the "FREEDOM TRAIN" into one of Washington's customary "gravy trains."

If American democracy really needs a shot-in-the-arm, there is no better place to start than right in Washington, D. C.

\* \* \*

## NEVADANS DON'T GAMBLE WITH THEIR OWN MONEY

When it comes to construction projects there is little evidence that contractors are willing to take a chance or gamble with ultimate ledger results in the State of Nevada, if a recent incident in the famed City of Reno is any criterion.

The Reno School District recently advertised for bids on a reinforced concrete and brick Veterans Memorial Grammar School consisting of eleven classrooms, an auditorium, and a cafeteria, to cost an estimated \$225,000.

The only bid received was from a San Jose, California, contracting firm who estimated the project would cost, according to specifications, something like \$797,000.

Many buildings exceed the initial estimates of construction costs, however, a differential of more than 300 per cent, is an item not to be overlooked.

## BUILDING COSTS

Reports of members of the Governing and Advisory Boards of the Associated General Contractors of America heard at the Fall Meeting of the organization early in October, indicated costs for most types of construction throughout the country are inching upward with the national trend toward higher wages and prices.

F. W. Parrott, President, declared: "One of our first duties as an industry is to inform the public that it should not believe that there can or will be quick or drastic reductions in construction costs. Because construction is so important to development of the nation, it is essential that it be carried out as efficiently, as economically, and as rapidly as possible."

The conference of top ranking construction men conceded that in an inflated economy subjected to upsets of international developments, construction costs can not return to prewar levels unless the nation suffers an economic catastrophe.

\* \* \*

## STRUCTURAL ENGINEERS ASSOCIATION OF CALIFORNIA—CONVENTION

The annual convention of the Structural Engineers Association of California is being held this month in Yosemite National Park, and according to all pre-convention indications the numerous technical and academic sessions which have been scheduled will be exceptionally well attended.

The benefits derived from attendance and participation in your own profession or industry convention, is limited solely by the desire of each individual delegate. The casual and informal discussions; the regularly scheduled technical programs; and the general exchange of thoughts and ideas with people engaged in the same line of endeavor, all offer unlimited possibilities for the individual seeking the answer to some of the complex problems confronting the Construction Industry today.

Public reaction is generally favorable towards members of a profession who seek through open conference an improved opportunity to serve their clients.

\* \* \*

## CALIFORNIA COUNCIL OF ARCHITECTS

Considerable credit is due those Architects who planned and carried to a successful conclusion details of the recent annual convention at Catalina Island.

*Your*  
**REQUIREMENTS  
POINT TO**  
*HAWS*



**You want *these features*** in the drinking fountains you specify: modern design, quality materials and workmanship . . . dependable operation and simple maintenance . . . durability and sanitation. In HAWS you get all these . . . plus a wide selection of models from which to choose . . . *and* your recommendations are backed by the reputation of a company which has built quality drinking fountains since 1909.

*Write today for catalog*

**HAWS DRINKING FAUCET CO.**

1808 HARMON STREET (SINCE 1909) BERKELEY 3, CALIFORNIA  
*Agents and Sales Representatives in All Principal Cities*

**"...YOUR INSULATING  
BUILDING BOARD PERFECT  
— SHIP US MORE"**

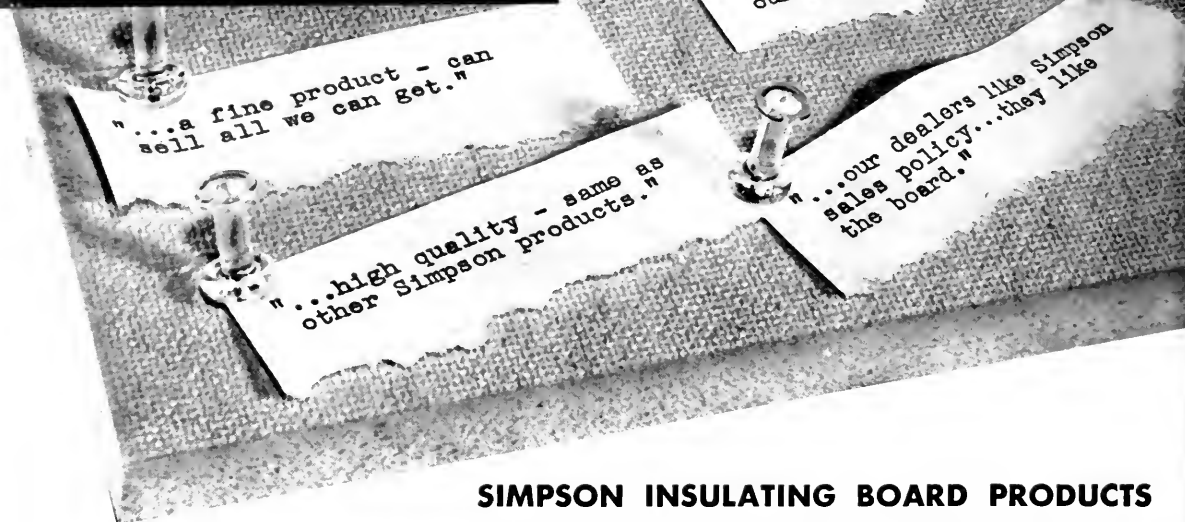

**SIMPSON INSULATING BOARD PRODUCTS  
RECEIVE ENTHUSIASTIC DEALER RESPONSE**



**Simpson**  
QUALITY SINCE 1895

**INSULATING BOARD PRODUCTS**



*Made in the West and allocated to western dealers*

**Q**UOTED ABOVE are a few excerpts from scores of letters from distributors and dealers who are enthusiastic about the new Simpson Insulating Building Board. They like the new building board . . . its structural strength . . . its new tapestry-like finish . . . its paint color . . . and its uniformity and general high quality. Only complaint from distributor and dealer alike is that they are not getting enough. Every letter and telegram says, ". . . ship us more." This we are trying to do. We are stepping up production at our new plant as shortages of equipment will permit. Our technical field service is available to architects, builders and dealers without charge.

WOODFIBER DIVISION • SIMPSON LOGGING CO.  
SALES DIVISION • SIMPSON INDUSTRIES  
1010 WHITE BUILDING • SEATTLE 1, WASHINGTON

**DISCUSS YOUR NEEDS WITH THE SIMPSON DISTRIBUTORS LISTED BELOW**

**ARIZONA SASH, DOOR & GLASS CO.**  
521 S. 9th Ave., Phoenix, Ariz.  
Phone: 3-3151

**ARIZONA SASH, DOOR & GLASS CO.**  
657 W. St. Mary's Road, Tucson, Ariz.  
Phone: 1699

**CALIFORNIA BUILDERS SUPPLY CO.**  
700 Sixth Avenue, Oakland 4, Calif.  
Phone: Highgate 6015

**CALIFORNIA BUILDERS SUPPLY CO.**  
19th & S Sts., Sacramento 14, Calif.  
Phone: 2-0788

**CALIFORNIA BUILDERS SUPPLY CO.**  
3180 Hamilton Ave., Fresno, Calif.  
Phone: 2-9470

**CALIFORNIA PANEL & VENEER CO.**  
955-967 So. Alameda St.,  
Los Angeles, Calif. Phone: Trinity 0057

**CONTINENTAL LUMBER CO.**  
P.O. Box 2042, Boise, Idaho, Phone: 450

**ELLIOTT BAY LUMBER CO.**  
600 W. Spokane St., Seattle, Wash.  
Phone: Elliott 8080

**ELLIOTT BAY LUMBER CO.**  
2712 McDougall St., Everett, Wash.  
Phone: Main 150

**ELLIOTT BAY LUMBER CO.**  
Box 188—Union Gap Station  
Yakima, Wash., Phone: 24671

**FROST HARDWOOD LUMBER CO.**  
Market of State St., San Diego, Calif.  
Phone: F-7224

**LUMBER DEALERS, INC.**  
T A Box 5222, Denver 17, Colo.  
Phone: Tabor 6141

**LUMBER DEALERS, INC.**  
108 South Main St., Pueblo, Colo.  
Phone: 4881

**LUMBER DEALERS, INC.**  
423 N. 33rd, Billings, Mont., Phone: 3911

**MORRISON-MERRILL & CO.**  
353 No. Park Street, Reno, Nevada  
Phone: 2-2196

**CHAS. E. SAND PLYWOOD CO.**  
1106 N.W. 16th Ave., Portland, Ore.  
Phone: Atwater 6421

**SIMPSON INDUSTRIES**  
1610 E. Washington Blvd.  
Los Angeles, Calif.  
Phone: Prospect 6183

**SIMPSON INDUSTRIES**  
Shelton, Wash., Phone: Shelton 611

**UTAH LUMBER CO.**  
333 W. 1st St., Salt Lake City 9, Utah  
Phone: 4-4318

**WESTERN DOOR & SASH CO.**  
5th & Cypress St., Oakland 7, Calif.  
Phone: Templebar 8400

# *Distinctive!.. and standardized for economy* THE FENCRAFT FAMILY\* OF WINDOWS

\*CASEMENT...PROJECTED...COMBINATION

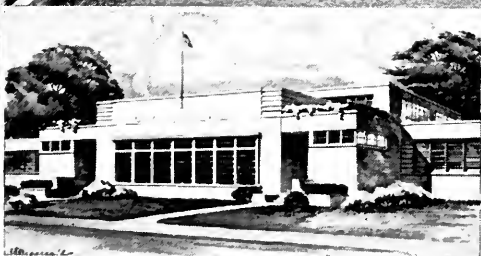
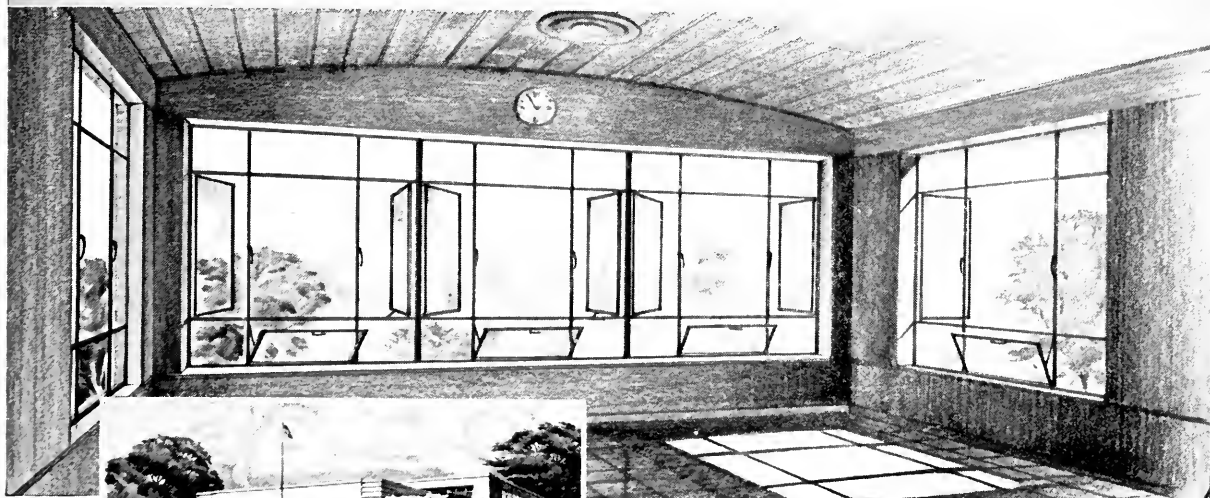

*Suggestion:* Provide more daylight and better ventilation for a fresh-air playroom in a school with Fenecraft Standard Intermediate Combination Windows, such as type 656 shown here. The sill vent provides excellent ventilation—deflects incoming air upward.

Distinctive window treatment is a mark of truly fine building. Of course, you want it in the buildings you are planning—along with high quality and marked economy.

Then take a good, close look at Fenecraft. These windows were designed for beauty... for easy operation, year after year... for weather-tightness... for safe cleaning... for abundant fresh-air ventilation. *And then they were standardized for economy.*

This standardization economy takes two forms—both important. There's economy in first cost because standardization simplifies

and speeds production procedures. And there are real economies in installation because of uniform installation details and co-ordination of window dimensions with those of wall materials.

Fencraft Windows are made of specially-designed casement sections—by craftsmen in the plants of America's oldest and largest steel window manufacturer. They're every bit up to the Fenestra standard. You can recommend them with confidence for the finest buildings. Fenecraft Windows are now being shipped to many localities. For product details, mail the coupon.

## *Fenestra*



FENCRAFT INTERMEDIATE STEEL WINDOWS

Detroit Steel Products Company  
Dept. AE-10  
2262 East Grand Blvd.  
Detroit 11, Michigan

Please send me data on types and sizes of the new Fenecraft family of Fenestra Windows:

Name \_\_\_\_\_

Company \_\_\_\_\_

Address \_\_\_\_\_

# When you specify INTERIOR COLORS remember the EYES of your client's employees

Color Engineering makes color functional as well as beautiful—corrects causes of eye-strain and fatigue—increases efficiency—reduces accidents

Paint is more than protection, important as that can be. Paint is COLOR—color that can weaken morale through strain and fatigue or raise morale through stimulation; color that can help a man do more and better work without strain, keep him alert and safer in danger areas.

That's why we suggest Color Engineering by Fuller for new construction, remodeling or maintenance work.

Our trained representative will talk Color Engineering with you, or with you to your customer—and without obligation. Why not have him demonstrate a Color Engineering survey—see exactly how this modern color approach meets the functional requirements of structures, plant machinery and equipment?

W. P. Fuller & Co., San Francisco.  
Branches and Dealers throughout the West.

## NEW structural steel Primer

Composite Red LZI (lead, zinc, iron) Metal Primer is far advanced over old rust inhibitors. Gives longer service at less cost. Definitely worth knowing!

## Fuller leads in floor finishes

Our specifications show why leading recreation arenas, institutions and industrial plants use Fuller floor preservatives. Use proof is the final proof!



FREE—For your files: Our 24-page book, "Color Engineering by Fuller." Full-color photos; complete text.



# NEWS AND COMMENT ON ART

**"MAN'S CHILD"** by Margaret Peterson.  
San Francisco Art Association Prize for  
Painting — Open Exhibition of Artist  
Members, San Francisco Art Associa-  
tion showing at the deYoung Memorial  
Museum.



## SAN FRANCISCO ART ASSOCIATION

Diverging from its regular order of shows, the San Francisco Art Association will hold an open exhibition from October 4 through November 4 at the de Young Memorial Museum in Golden Gate Park.

The exhibition will consist of drawings, print and painting media, and sculpture, representing approximately 120 pieces.

The jury of Awards will comprise Alfred Krankenstein, Dr. Walter Heil, Charles Lindstrom, Dr. Jermayne MacAgy and Dr. Stephen C. Pepper, Anton Refregier and Jean Varda will act as alternates.

The exhibition arrangements were under direction of the Artists' Council of the Association.

## CALIFORNIA PALACE OF THE LEGION OF HONOR

Thomas Carr Howe, Jr., director, has announced the following schedule of exhibitions and special events for October:

**EXHIBITIONS:** PAINTINGS LOOTED FROM HOLLAND, opening October 9; PAINTING IN FRANCE, 1939-1946, opening October 9; RENAISSANCE VENICE—Lent by Life Magazine, opening October 15; SCALAMANDRE TEXTILES, closing October 3; CERAMICS by Whitney Atchley, through October.

The Alma de Bretteville Spreckels Collection of Sculpture by Auguste Rodin.

The Mildred Anna Williams Collection of Paintings, Sculpture, Tapestries and Furniture.

The Collis Potter Huntington Memorial Collection of 18th Century French Paintings, Sculpture, Tapestries, Furniture and Porcelain.

**EDUCATIONAL ACTIVITIES:** A Tour of the Museum Collections will be given every Wednesday and Friday in October at 2:30 p.m. The group will meet in the Sculpture Court. Conducted by Katharine L. Parker.

Saturday morning children's classes were resumed on Saturday, October 4, at 10:00 a.m.

The painting class for adults was resumed on Saturday, October 4 at 2:00 p.m.

**ORGAN PROGRAMS:** Organ Recital by Uda Waldrop, every Saturday and Sunday, 3 p.m.

Organ Concert Broadcast at 3:30 p.m. Saturday.

## CITY OF PARIS ART IN ACTION

The Pacific Coast Textile Exhibition instead of holding a competitive exhibit, as in previous years, is inviting the work of a few designers of the highest standard from the Pacific Coast to be shown in the textile show this year in the Rotunda Gallery from October 15 to November 1.

During October the Art in Action Shop will feature "Pictures of the Month" by Leah Rinne Hamil-

(See Page 31)

# LANDSCAPE

**NED S. RUCKER,**

**Landscape Architect**

**Berkeley, California**

**Member Association of Landscape Architects**

## **A PATIO GARDEN**



*Photos by Philip Fern*



# ARCHITECTURE

**WHITE PERGOLA** extends from top of reinforced concrete retaining wall over two small seats surrounded by green shrubbery and brilliant flowers.



The kidney shaped patio garden designed by Ned S. Rucker, Landscape Architect, to enhance the barren hillside outlook from the private office of Mr. Claude C. Gillam, owner of the Hotel Claremont, Berkeley, California, is beautifully carried out in an architectural manner with colors of soft grey on the retaining wall and of the basalt wall blocks used for paving and as coping on the walls of buff Sonoma stone supporting the raised beds and pool. The buff is repeated in two lines of quarry tile used as a border and pattern throughout the paving. The retaining wall is coped with a fine red brick which repeats the brick of the fireplace in the office.

Looking out through the wide French doors of the owner's office the slightly raised pool is the center of interest. On both ends of the pool are raised beds with green shrubbery and brilliant flowers breaking the grey of the wall.

The garden has been excavated back into the hill. This determined the horizontal arch shape of the retaining wall which is reinforced concrete of the cantilever type. To reduce the glare from the afternoon sun the wall has been plastered in a rough texture and given a grey tone.

The raised beds are of various heights and widths to increase the interest of the walls and planting.

Built against these beds are two small white wood seats. Over one of these seats is a white pergola using the cantilever principle extending out from the top of the retaining wall.

The garden has very effectively accomplished its purpose of creating a pleasing restful view in a difficult location and has created a fitting setting for the office of the owner of the hotel.



IRWIN M. JOHNSON, Architect

James Stevenson Studio, Photo

# NEW PLANT FOX TILE COMPANY Oakland, California

Architects and contractors who have seen the new show room and warehouse of the Fox Tile Company in Oakland, California, say it is one of the most attractive and best arranged buildings of its type in the West.

The plant was designed by Irwin M. Johnson, Architect, who developed a happy combination of beauty and utility with a modern front and roomy interior.

Raymond L. Fox, owner and manager of the Company, has operated the business since 1939, at which time he maintained a small shop at his residence in Oakland. For the past four years the Company has expanded, despite crowded conditions at its present site, and last year additional space was leased.

Now the old building has been modernized and enlarged with a 20 by 125 foot unit of Class C construction. The new structure is two stories in height with general offices, including the private office of Mr. Fox, and show rooms on the ground floor. Storage room is also provided in the rear of the general offices, while back of the show room, which is attractively decorated in ceramic and faience tiles, are several small booths for the salesmen. Showers are provided for the employees on both floors, and an electric refrigerator filled with soft beverages has also been provided for the employees.

The Company operates a fleet of ten trucks which make deliveries to points as far distant as 500 miles, and some of the recent tile contracts



**LINOLEUM and TERRAZZO DISPLAY ROOM . . . Fox Tile Company**

of the firm include: the Berkeley General Hospital, Golden State Theatres, Howard Taft School in San Mateo County, Conway-Culligan tract houses in San Mateo county, Henry Dolger houses in San Francisco and Sacramento county, Detention Home and the Modesto High School.

In addition to ceramic and faience tile, the Fox Tile Company carry a complete stock of linoleum, terrazzo, and bath room accessories.

Arthur Nichols is in charge of terrazzo work, while William Smith handles linoleum and asphalt tile installations.

**VIEW OF TILE SHOW ROOM FROM GENERAL OFFICES**



# AMENDMENTS

## To the California State Housing Act NOW IN EFFECT

Important amendments to the California State Housing Act took effect on September 9, 1947, under the provisions of Chapter 1493, Statutes of 1947, enacted at the recent session of the Legislature.

The State Housing Act governs the construction, maintenance, safety and fire protection of apartment houses and hotels throughout the State. The provisions of the Law also apply to dwellings in cities. The construction provisions are enforced by local Building Departments and the maintenance, sanitation and safety features are enforced by local Health Departments. Local governing bodies are empowered, under the provisions of the Law, to designate any other local departments as the enforcing units for the Act other than those mentioned above. The Housing Division of the Department of Industrial Relations is the only State enforcement agency of the Act, and its scope of authority extends throughout California.

Some of the major amendments to the Housing Act applicable to hotels and apartment houses, are as follows:

A section has been added to provide that any doorway furnishing public egress shall be not less than 35" in clear width and 79" in clear height. Hallway and stairway widths have been changed to coincide with the general run of local codes. A further addition provides that no transom shall be installed opening from any room into any public hallway or passageway.

The stairway chapter of the Law has been given a general overhauling and revision. It provides that all interior public stairways in apartment houses and hotels three or more stories in height, shall be closed off with fire resistive walls and doors at each story level. This will prevent the spread of flames from one story to another. Provision is also made that buildings of this character shall have interior basement and cellar stairways closed off as provided for other stairways. This requirement will, in the same manner as the enclosed stairways, aid in confining flames to their point of origin.

Additional amendments to the State Housing Act require that in the construction of apartment houses 3 or more stories in height and containing more than 15 apartments, and hotels 3 or more stories in height and containing 20 or more guest

rooms, approved automatic or manually operated fire alarm systems designed to warn the occupants of the building in the event of fire must be installed. These installations must be made in accordance with the standards of the National Board of Fire Underwriters.

The new legislation also requires that in the erection of apartment houses and hotels basements or cellars containing more than 1800 square feet of floor area or any basement or cellar compartment or room used for the storing of combustible materials be equipped with automatic sprinkler systems of a type designed by the National Board of Fire Underwriters. Boiler rooms, central heating rooms, and bank vaults are excluded from this requirement, as they will have other protection.

Apartment houses and hotels will be required to provide portable fire extinguishers placed in accessible and conspicuous places along the hallways, in garage spaces, paint or spray maintenance rooms, amusement, entertainment, bar, reception, lobby, public dining rooms, public kitchens and in rooms used for similar purposes.

Further requirements are flame retardant treatment of decorative material, such as drapes, hangings, curtains, etc., in any amusement, entertainment, bar, reception, lobby, public dining room, or room used for similar purposes, or along the walls, and ceilings of any public hallway or along the walls and on soffits of any interior public stairway in any apartment house or hotel. False ceilings of combustible material will not be permitted in any of the above mentioned rooms or places.

Doors or windows furnishing required egress from any hotel or apartment house must be of a type which can be readily opened from the interior of the building without the use of a key, or any special knowledge or effort. Every apartment house 3 or more stories in height containing more than 15 apartments and every hotel 3 or more stories in height containing 20 or more guest rooms hereafter constructed must be equipped with wet standpipes and hose to reach all parts of every floor of the building. This is a much needed fire protective measure.

It will hereafter be unlawful for any owner, operator, lessee or other person in charge of any apartment house or hotel or any occupant thereof

(See Page 35)



FIVE FIFTY GRANT AVENUE . . . San Francisco, California

# A CONTEMPORARY STORE IN CHINATOWN

San Francisco

By WILLIAM W. WOLF, A.I.A., Architect



The "Mane On" Store at 550 Grant Avenue, main thoroughfare of Chinatown. Its owner, Raymond Tong, an art dealer and master of window display, wanted a modern store front on occasion of the remodeling of the building, with a functional and economical layout of the store taking care of Grant Avenue's specific conditions regarding the many tourists invited to "take a look-see." The

**CLOSE-UP** view of the four foot in diameter circular neon sign above the entrance with Chinese lettering "Mane On" which sparkles with all the brilliance of San Francisco's fascinating Chinatown at night.

*Hassman-Myers, Photos*



**INTERIOR view looking towards the steel covered entrance door. Layout of the store is economical and functional.**

architect faced the problem to fit the appearance of the store to the neighboring pagoda towers and iron grilled balconies with a distinct oriental touch. His design was conceived as an effort to create a style which blends the serenity of the old Cathay with the modernism of new America without the Hollywood touch.

The merchandise to be displayed and sold is impulse—and luxury goods like antiques, cloisonet

wares, vases and bowls from the seventeenth century and blanc de chine figurines of Kwan Yin, the Goddess of Mercy.

The conception of the architect, likewise trying to overcome the handicap of a rather narrow street and the size of the lot puts a strong accent on the front in arranging as eye-catch a circular box with Chinese lettering "Mane On" above the entrance; according to the well established rules of merchandising psychology this unusual sign, four feet in diameter, arouses the interest of the passers-by by day and night and, together with the ornamental lettering "Mane On" in heavy bronze, reflects immediately the Chinese character of this specialty shop. At night this lettering sparkles in all the brilliant colors of Chinatown and has no illumination of its own; the circular box, however, shows during the night a dark silhouette of the Chinese lettering on red opaque glass, very intensely lightened with evenly dis-

(EDITOR'S NOTE: Architect William W. Wolf fled from Vienna in 1939, where he was employed in one of the City's larger construction firms, having received his education at the Vienna Technical University and in 1930 represented Austria at the International Architectural Congress at Budapest. Going to France and later London, Wolf then came to America where he engaged in architectural work for the Henry J. Kaiser interests during the War, subsequently opening his office for the practice of architecture in San Francisco.)

tributed neon tubes behind. The look is guided to the entrance on the same center line and the two display windows, the larger one for general display, the smaller one for jewelry. Both are set back in order to create an inviting space and the ornamental large "550" in bronze of the terrazzo floor attracts again the attention of a passer-by. A heavy framing with flutes, horizontally and vertically keeps all the elements of design together and helps to accentuate the main entrance.

The layout of the store is economical and functional and accommodates the many sight-seeing tourists and the factual sale. On the owner's wish Chinese colors, especially jade green, are used for the Vitrolite of the front, the terrazzo floor outside, the interior floor of asphalt tiles in two shades, and the various fixtures; vivid colors, however, are avoided in order not to compete with the displayed merchandise. The steel covered main entrance door has a combination grille-pushbar, ornamental in heavy bronze. The display window

for jewelry has a service mirror door. The general display window is open from inside. In order to keep the display arrangement flexible there are several short panels which can be located or removed independently; they serve as screen and likewise for display of laces and embroidery, if so desired. A sliding panel from bottom to top of the window serves to display paintings but is likewise removable. Three masonite panels on the floor of the display case can be taken out and covered with material of any texture or color according to the various arrangements of the owner. Aluminum moulding are used because of their flexibility and the ability to give the impression of a full-open front with no projecting members indicating the glass line. All walls and ceiling of the building are painted in delicate colors and ventilating wall heaters without outlets are provided.

Different types of display cases, counters, etc.,

(See Page 44)

**STAIRWAY to display balcony and rear arrangement of store.**



# PERFORMANCE STANDARDS

## ESTABLISHED - Fir Plywood Industry

Higher performance standards for adhesives used in all Interior type Douglas fir plywood top the list of product refinements set forth in the new U. S. Commercial Standard CS45-47 adopted by the Pacific Northwest panel makers who produce two-thirds of the nation's plywood.

Other improvements of quality under the standard, promulgated through the National Bureau of Standards and effective for new production from September 15, include:

1. Higher specifications for inner plies of all grades of both Exterior and Interior types of Douglas fir plywood.
2. An improved Plywood sheathing grade.
3. Simplification of grades through combining the old Plywood (wallboard) grade and Plypanel Sound 1 Side grade. Plypanel Sound 1 Side grade now becomes the all-purpose interior panel material.

"That which is special now has become regular," Managing Director Charles E. Devlin of Douglas Fir Plywood Association of Tacoma, Wash., commented in explaining the rigid new performance requirements for adhesives in interior type fir plywood. "The highly moisture resistant (but NOT waterproof) adhesives previously used only in 'special' or 'premium' quality Interior fir plywood, under the new standard is the regular glue for Interior type Douglas fir plywood."

### Performance Upped

These previously-considered "special" adhesives originally were introduced in the Plyform (concrete form) grade fir plywood nine years ago to assure a panel for form construction that can be used numerous times on concrete jobs, the plywood official said. This type of adhesive recently has been termed "10 cycle glue," "concrete form glue," and "CCF glue" as well as "special" or "premium."

Formerly, the test for regular Interior plywood was two cycles of wetting and drying without delamination. As set forth in the new Commercial Standard, all Interior type fir plywood now is produced to withstand an average of 10 cycles of wetting and drying without failure.

There are just two types of Douglas fir plywood, the type being determined by the glue used to bond the plies together. Exterior type fir plywood is manufactured with completely waterproof adhesives and is intended for permanent outdoor and marine uses! Interior type fir plywood is bonded with highly moisture-resistant (but NOT waterproof) glues and intended for inside uses and such structural parts of the house as sheathing and sub-flooring.

Within each type there are several appearance grades, the grade being established by the appearance properties of the wood in the outer or face plies rather than with regard to the adhesive.

### Limitations Set

The raising of the quality standards for all Douglas fir plywood is exemplified in stricter limitation of defects permitted in inner plies of the Exterior type material under CS45-47. This tightening of the inner veneer construction is to assure greater serviceability quality of outer plies is, of course, determined by appearance requirements for the various grades.

Limitations, although less stringent, also are announced for the veneer of inner plies of Interior type panels.

Also, under the new standard, certain other western softwood species are allowed for inner plies of several grades of Interior type plywood, but Plyscord (sheathing grade) and Plyform must be entirely of Douglas fir. Similarly, all inside as well as outer plies of the Exterior type fir plywood must be of Douglas fir veneer.

The new, more stringent specifications for glue performance in interior plywood is particularly important in the Plyscord grade as such panels may be subjected to wetting from rain during construction. As well, as veneer specifications for outer plies of this grade of material have been modified to provide a structurally stronger panel. Plyscord remains, however, a rough, unsanded material for utility use where appearance is of little consequence.

### Grades Combined

In effect, the old Plywood grade, which has prov-

(See Page 44)





**AERIAL VIEW** of the Rexall Drug Company's new "horizontal skyscraper."

# WORLD HEADQUARTERS

## Office Building Rexall Drug Company

### Los Angeles, California

By **ALBERT F. ROLLER, Architect, A.I.A.**

Because of the firm conviction of Justin W. Dart, President of the Rexall Drug Company, that California is the best place for the management of business, there is now being completed at the Southeast corner of Beverly and La Cienega Boulevards in Los Angeles, the World Headquarters Office Building for the world's largest drug store chain.

Technically, this building is an ideal adminis-

tration plant. Architecturally, it is intended as a monument to modern business. From the structural standpoint, every precaution has been taken to make it as perfect as modern engineering design and materials can.

Soil analysis disclosed the necessity of placing the building on a foundation of 1150 step tapered concrete piles, assuring a uniform settlement.



**ENTRANCE** to the Owl Rexall Super Drug Store which is located in the northwest corner of the new world headquarters building in Los Angeles.

The super structure is two stories high, approximately 325'x400' in size—an area of about 3 acres, which provides off-street parking for over 350 cars on the balance of the 6-acre site.

The square footage contained in the finished basement and first and second floor areas would create a 20-story building covering a ground area of approximately 100'x170'.

Extensive basement and sub-basement areas, housing the intricate mechanical systems and for drug storage, have been provided.

### **REXALL DRUG COMPANY Los Angeles, California**

The following firms, participants in the construction of the World Headquarters office building of the Rexall Drug Company, Los Angeles, have display advertisements in this issue.

**GENERAL CONTRACTOR:** The Louis C. Dunn Co.

**ACOUSTICAL ENGINEERS:** The Harold E. Shugart Co., Inc.

**STRUCTURAL STEEL:** Harold E. Peterson  
Sheet Metal  
Air Conditioning  
Kitchen Equipment

**LIGHTING FIXTURES:** Sunbeam Lighting Co.

**VENETIAN BLINDS:** Metropolitan Blind Co.

**MARBLE & TILE:** Bruner Marble & Tile Co., Inc.

**FLOOR COVERINGS:** Jack Freeman

**PUBLIC ADDRESS SYSTEM:** Otto K. Olesen  
RCA Music Systems

**SPARKLE FINISH:** Super Concrete Emulsions, Ltd.

**LOOKING** through the circular, structural plate glass window at front of Super Drug Store. Terrazzo flower box in foreground is planted with shrubs.

Showcases are lighted above by 17 soft spot-lights. The large Dali-esque soffit in background is interesting.



## . . . REXALL SQUARE, Los Angeles

The building has been constructed around four spacious interior courts, which will be interestingly landscaped, and which in addition to providing light to the large interior floor area, will serve as recreation and dining areas for the 1000 employees.

Access for the public to two of these unique court areas is through the world's largest drug store occupying the first floor corner area of the building.

A fountain and dining area seating 200 will occupy the La Cienega frontage and an additional 200 may enjoy a luncheon or a dinnertime

buffet service in the charming garden atmosphere of the outdoor courts.

The building can be entered from any one of the four sides, the main entrance being the central motif on Beverly Boulevard, with the personnel entrance on La Cienega Boulevard.

The main entrance, emphasized by the four rectangular polished black granite columns, leads into a lobby flanked by two reception rooms, styled for the comfort of visitors who might be required to wait.

The lobby with its green and black and red marble walls and a black terrazzo floor presents

(See Page 25)

### MAIN ENTRANCE

Rexall Drug building covers three acres of a six acre lot and includes seven research laboratories, merchandise display room and 200 private offices as well as the Owl Rexall Drug Store. Off street parking will provide for 300 cars.

The building has four patios, or light courts.





**UPPER PATIO** shows use of striking serpentine wall and combination of red bricks and chemically treated red-wood blocks for walkways. Patio provides natural light for inside offices.

**ONE OF TWO MAIN STAIRWAYS** leading to second floor from entrance lobby. Columns in foreground are verde-alps marble. Walls are travertine.

**LOWER PATIO** used for outdoor dining room, accommodates 200 people. Umbrellas equipped with fluorescent lighting for night. Note tree and planting.





**ABOVE:** Beauty Bowl in the new Owl Rexall Super Drug Store. Circular light trough overhead has one soft spotlight for each of the 17 sectional cases.

**BELOW:** Island display cases fit snugly around center pillars which are painted a rich, antique bronze. Spots in ceiling illuminate store interior and show cases.



**REXALL SQUARE, Los Angeles . . .**



**LIQUOR ROOM** in drugstore is, actually, a store within a store, since it is completely enclosed by structural plate glass and has own private entrance from general store interior. The lighting dome is styled in the tone of an old Dutch wine cellar.

**ENDLESS LIGHTING TROUGHS** around wall alcoves makes the store light pleasant and inviting. The store has 32,000 square feet of floor space, all of which is well lighted.



**Gales  
Fountain  
Room**

**Accommodates  
225 people**



(From Page 21)

an interesting approach to the two main staircases, the first floor corridors and to the corner drug store.

On the first floor of the building are located the merchandising offices and the merchandise display room where every facility will be provided for setting up standards not only for the 10,000 franchised druggists, but also for all of the Owl, Sontag, Liggett and Renfro chains which are owned by the company.

The Publicity and Advertising Departments are also on the first floor, as are the Construction,

Personnel and Medical Departments and the extensive Mail Room where 20,000 pieces of mail will originate daily.

One of the unique service features on this floor is a 3-chair barber shop, exclusively for the convenience of the building population.

The second floor is occupied by the General Executive Offices, Legal Department, Accounting Department, and Directors' Room, one wall of which will be covered by a mural 32'-0" long and 20'-0" high of the map of the United States, whereon in picturesque fashion will be depicted the location of the main manufacturing, warehousing

(See Page 27)



**OFFICES of J. W. Dart, president, are paneled in bleached black walnut matched by graceful black walnut desk. Ceiling, below and above light cove, is edged in bleached black walnut strip.**

RIGHT is shown reception room.  
LOWER LEFT is El Patio Dining  
Room and Terraces; other view is  
Executives' Dining Room.



All  
Floor Coverings  
in World Headquarters

REXALL DRUG  
COMPANY

installed by

**JACK FREEMAN**

Floor Coverings

460 N. Rodeo Drive  
Beverly Hills, Calif.

Linoleum	Carpeting
Asphalt Tile	Broadloom
Rubber	Rugs
Lino Tile	

Bradshaw 23374  
Crestview 11109

## AN RCA Paging System

and two RCA Music Systems designed and installed  
by us gives the Rexall organization music when and  
where they want it—locates personnel quickly with  
voice paging. Specify RCA for best results.

## OTTO K. OLESEN COMPANY

Exclusive RCA Sound Systems Distributors

1560 N. Vine St.

Hollywood 28, Calif.

San Francisco Office 74 Tehama St.





## REXALL SQUARE, Los Angeles . . .

(From Page 25)

and office locations. The map will be flanked by a heroic figure of a Rexall pharmacist holding a beaker in the process of compounding a prescription. The mural will be visible from Beverly Boulevard, as the opposite wall is entirely of glass from floor to ceiling. The mural is by Don Clever, California artist.

A specially built oval walnut table 22 feet long will accommodate the Directors at their meetings.

On the second floor there will also be a trainee soda kitchen, and an officers' conference dining

(See Page 30)

### **Cemelith Sparkle Finish**

BEAUTIFIES AND PROTECTS  
EXTERIOR OF NEW

**UNITED REXALL**  
HOME OFFICE

Manufactured and Applied by

**SUPER CONCRETE EMULSIONS, Ltd.**

1372 E. 15th St.  
Los Angeles 21  
PRospect 4076

420 Market St.  
San Francisco 11  
EXbrook 2-5566

## VENETIAN BLINDS

featuring

**ALUMILITED ALUMINUM FINISH**

installed in the

**REXALL DRUG CO.**

**WORLD HEADQUARTERS**

Los Angeles

by

**METROPOLITAN BLIND COMPANY**

2362 W. Washington Blvd.

Los Angeles 7

### **Bruner Marble & Tile Co., Inc.**

**Decorative Marble and Tile  
Contractors**

ALBERENE SOAPSTONE  
LABORATORY EQUIPMENT

**1012 Architects Building**

816 West Fifth Street

Michigan 3817

MADison 8237

Los Angeles 13, California

## GENERAL CONTRACTORS

For

World Headquarters

Rexall Drug Company

Los Angeles

---

---

THE LOUIS C. DUNN CO.

417 South Hill Street

Los Angeles 14, California

MIchigan 7085



# Announcing



## SUNBEAM'S COMPLETE NEW ADVANCED LINE OF FLUORESCENT LIGHTING FIXTURES

*Sold Only Thru Leading Electrical Jobbers*

**THE ANSWER TO THE NEEDS OF MODERN LIGHTING**

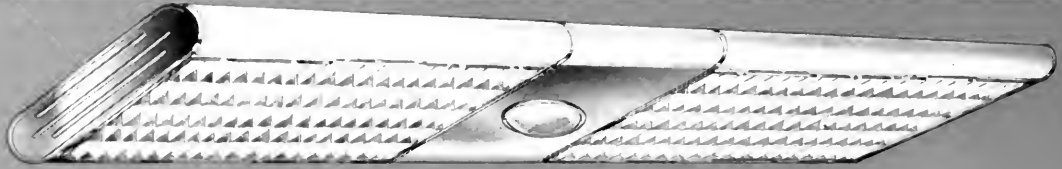

THE SUNBEAM "PRESIDENT"  
1504-48 AND 1504-5 CONTINUOUS RUNS.

SUNBEAM Leads the Nation in Perfect Modern Design Fluorescent Fixtures

All SUNBEAM Fixtures Can Be Mounted Directly on Ceiling, Suspended or in Continuous Runs

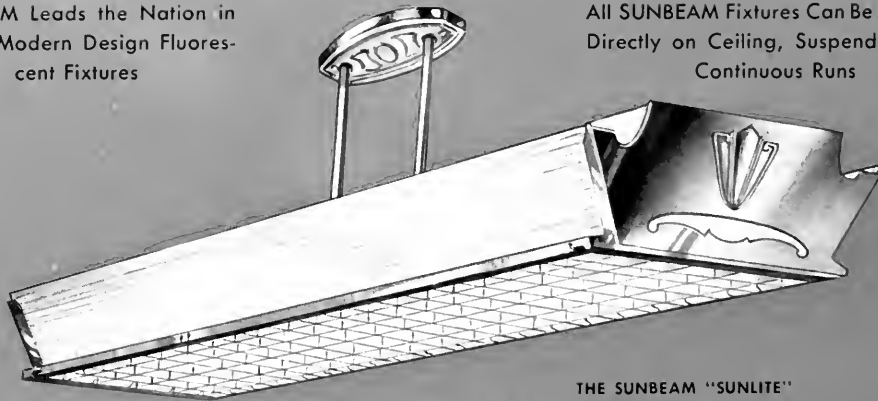

THE SUNBEAM "SUNLITE"  
L6002-48 AND L6004-48 HINGED LOUVRE



THE SUNBEAM "STREAMLINER"  
4003-48 OR 4004-48 WITH 4000-5 SPOT. CONTINUOUS RUNS.

There are 2500 Sunbeam Streamliner Fixtures installed in the new United Rexall World Headquarters Building in Los Angeles. These were sold through the Westinghouse Electric Supply Company and installed by Fischbach & Moore, Inc., electrical contractors. This Sunbeam achievement provides an excellent medium for contributing to the advancement of better seeing through better lighting

**There Is a Sunbeam Fluorescent Fixture for Every Purpose —  
Ask Your Jobber for a Catalogue of Our Complete Line**

DESIGNERS AND  
MANUFACTURERS  
OF



FLUORESCENT  
LIGHTING  
FIXTURES

777 EAST 14TH PLACE

LOS ANGELES 21, CALIFORNIA



### **THE BOARD OF DIRECTORS ROOM**

**Rexall Square, Los Angeles**

The permanent mural painted on a concave wall was created by Don Clever of San Francisco and is 32 feet by 20 feet. It has an undercoat of 5000 sheets of featherweight aluminum foil. The table is of bleached black walnut, to match the panelling of the room, and is 22 feet long and 11 1/2 feet wide at the center. Directly above the large table is an elliptical light cove having the exact measurements of the table and containing endless neon tubes.

## REXALL SQUARE, Los Angeles . . .

(From Page 27)

room opening onto a dining terrace, so landscaped to insure privacy without being obtrusive.

Throughout the building in repetitive locations,

are the men's and women's toilets and cloak rooms and the required service rooms.

Conference rooms of ample size are located at frequent intervals so any group or staff can make use of such spaces.

The largest air-conditioning system ever to be installed on the Pacific Coast in an office building has been incorporated into the structure. Two 250 H. P. centrifugal compressors will supply the chilled water for the cooling cycle. The building is divided into 33 zones.

The aluminum windows throughout merely serve to admit light and as a protection from the elements. They need never be opened except for cleaning the exterior of the glass.

The exterior of the building is architectural concrete and in designing the building it was the architect's wish to express the long horizontal elements in a continuous form rather than as a veneer with joints. Concrete was the only medium in which this could be properly done. The building is finished in a color closely resembling the natural color of the material.

Lighting effects make this an outstanding and interesting structure at night as well as by day.

### THE HAROLD E. SHUGART COMPANY

ACOUSTICAL ENGINEERS AND CONTRACTORS

911 NORTH SYCAMORE AVENUE

LOS ANGELES 38, CALIFORNIA

Four Carloads of Acousti-Celotex effectively quiet the World Headquarters of the Rexall Drug Company.

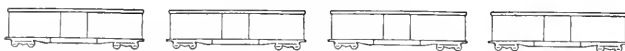

## HAROLD E. PETERSON

Sheet Metal • Air Conditioning  
Kitchen Equip • Structural Steel

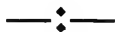

1350 Elwood St.  
TRinity 4886  
Los Angeles, Calif.

Established in 1936—One of the Largest  
and Most Modernly Equipped Plants on  
the Pacific Coast.

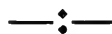

Contractor for Rexall Drug Co.  
World Headquarters



**Arizona Chapter:**

James Macmillan, President; Arthur T. Brown, Secretary, 740 N. Country Club Road, Tucson, Arizona.

**Central Valley of California:**

Herbert E. Goodpastor, President; Frank V. Mayo, Secretary, 307 Exchange Building, Stockton 2, California.

**Colorado Chapter:**

Raymond H. Ervin, President; James M. Hunter, Secretary, 2049 Broadway, Boulder, Colorado.

**Montana Chapter:**

Ralph H. Cushing, President; H. C. Cheever, Secretary, Montana State College, Bozeman, Montana.

**Northern California Chapter:**

Hervy P. Clark, President; Lester Hurd, Vice-President; Ralph Pollack, Secretary; William C. Ambrose, Treasurer; 605 Market Street, San Francisco.

**Oregon Chapter:**

Walter E. Church, President; Frank Reehr, Secretary; Office 619 Builders Exchange Bldg., Portland 4, Oregon.

**San Diego Chapter:**

H. Louis Badmer, President; Louis J. Gill, Secretary, 203 Granger Building, San Diego, California.

**Santa Barbara Chapter (California):**

Chester L. Canola, President; Robert I. Hoyt, Secretary, 116 E. Sola St., Santa Barbara, California.

**CALIFORNIA COUNCIL OF ARCHITECTS**

Vincent Palmer, President; Andrew Hass, Vice-President; A. C. Martin, Jr., Secretary-Treasurer; 369 Pine St., San Francisco 4.

**Southern California Chapter:**

Adrian Wilson, President; A. C. Martin, Jr., Vice President; Walter L. Reichardt, Secretary; George E. Gable, Treasurer; Chapter Headquarters, 3757 Wilshire Blvd., Los Angeles 5, California.

**Spokane Chapter (Washington):**

Noel E. Thomson, President; Kenneth D. Stormont, Secretary, Hutton Building, Spokane, Washington.

**Utah Chapter:**

George Cannon Young, President; Theodore R. Pope, Secretary, 29 South State Street, Salt Lake City 1, Utah.

**Washington State Chapter:**

Clifton J. Brady, President; Arrigo M. Young, Vice-President; John Richards, 2nd Vice-President; Ralf E. Decker, Sec.; Waldo B. Christenson, Treasurer, Office 1411 Fourth Avenue Building, Seattle 1, Washington.

**Hawaii Chapter:**

Kenneth W. Reehrig, President; James Morrison, Secretary, 334 Federal Bldg., Honolulu, T. H.

**SOUTHERN CALIFORNIA CHAPTER**

The regular October meeting was held in conjunction with the 20th Annual Convention, California Council of Architects, on Catalina Island. Many items developed during the four day conference of Western architects will be reviewed at subsequent Chapter meetings.

\* \* \*

A. C. Martin, Jr., will represent the Chapter at the Convention of Pacific Coast Building Officials Conference, October 21 to 24, South Rim of the Grand Canyon, Arizona.

\* \* \*

Walter Hagedohm will represent the Chapter at the annual Convention of the Structural Engineers scheduled for October 16 to 19 at Yosemite.

\* \* \*

The Los Angeles County Board of Supervisors has increased the number of technical positions allowed, such as Architectural Draftsmen, Senior Planning Assistants, etc., in conjunction with the work of the Regional Planning Commission of which Col. William J. Fox, is the Chief Engineer.

**ARCHITECTURAL VIOLATIONS**

Leo G. Whitaker, special agent for the California Board of Architectural Examiners, reports that the total complaints received this year by the Board have numbered 389.

Of the total complaints some 336 have already been investigated and 7 have been prosecuted.

Increased activity throughout the construction industry has increased the work of the department.

**ARCHITECTS RECEIVE CALIFORNIA CERTIFICATES**

The California State Board of Architectural Examiners have announced the following were granted Certificates to practice Architecture in California.

Elso B. DiLuck, Fresno; Dorothy D. Gray, Redwood City; W. G. Knoebel, and Benjamin Shapiro, St. Louis, Missouri; Herbert T. Seipel, Carmel; Eugene Benham, Columbus, Ohio; John D. Forsyth, San Clemente; Tra E. Tron, and John N. Sill, Pasadena; Norman K. Fugelso, Sherman Oaks; Frank R. George, San Diego; Stewart S. Granger, Glendale; Everett H. Hughes, Montebello; Yukio Kako, Chicago; Stanley A. Moe, North Hollywood; and William S. Morris of Los Angeles.

Bolly A. Andrew, Carlton L. Camp, Edward H. Fickett, John E. Fortune, M. E. Fuller, Gus W. Kalionzes, Charles F. Nagel, Charles A. O'Grady, Dan S. Palmer, Louis W. Pursel, Romeo A. Rodriguez, Henry N. Silvestri, Robert E. Smith, Raphael S. Soriano, Marion J. Varner, Donald E. Wilcox, Carleton M. Winslow, Jr. and Hermann E. A. Figgé, all of Los Angeles.

George V. Banning, John W. Gloe, Leslie C. Irwin and Carl H. Riesen of San Francisco; Earl V. Barker and Herbert E. Riley, Whittier; Robert E. Brown and Walter W. Wilkman, North Hollywood; Vincent D. Case, Montrose; Dan C. Cherrier and Francis O. Merchant, Long Beach; Eugene E. Crawford, Mill Valley; Roy M. Drew, La Canada; Robert N. Eddy, Bakersfield; DeWitt J. Griffin, Alhambra; Franklin D. Howell, III, Pasadena; Robert M. King, Pomona.

(See Page 40)

# WITH THE ENGINEERS

Structural Engineers Association of Northern California

William W. Moore, President; John A. Blume, Vice President; Franklin P. Ulrich, Treas.; G. A. Sedgwick Sec.; Wm. H. Popert, Consultant; Office, Room 712, 57 Post St., San Francisco, Phone SUtter 1-5474. DIRECTORS, Mark Falk, M. V. Pregnoff, and R. D. Dewell.

American Society of Civil Engineers San Francisco Section

Sidney T. Harding, President; Lawrence A. Elsener, Vice President; John E. Rinne, Secretary-Treasurer, 225 Bush Street, San Francisco 20.

Puget Sound Engineering Council (Washington)

R. E. Kister, A. I. E. E., Chairman; E. R. McMillan, A. S. C. E., Vice Chairman; L. B. Cooper, A. S. M. E., Secretary; A. E. Nicherson, I. E. S., Treasurer; Offices, L. B. Cooper, c/o University of Washington, Seattle 5, Washington.

---

---

## STRUCTURAL ENGINEERS ASSOCIATION OF NORTHERN CALIFORNIA

October's regular meeting featured the Annual Convention at Yosemite, with an excellent turnout of members. More about this Convention later.

GEORGE T. McKEE is instructing ELEMENTS OF STRUCTURAL DESIGN, ELEMENTARY DESIGN IN STRUCTURAL STEEL AND WOOD, ELEMENTARY DESIGN IN REINFORCED CONCRETE, and INTRODUCTION TO CONTINUITY OF FRAMED STRUCTURES in the Division of Engineering Extension at the University of California in San Francisco.

JOHN CHERNO is now located in the Philippine Islands.

RICHARD D. KARR is now with the Bechtel Corporation, San Francisco.

FRANKLIN P. ULRICH will represent Association at the annual convention of the Pacific Coast Building Officials Conference, October 21 to 24 at the Grand Canyon. Other members attending included M. C. Poulsen, Milo S. Farwell, Ralph D. Rader, Artheu C. Horner, George S. Solnar, and Wm. H. Popert.

The fall STRUCTURAL SEMINAR, scheduled for each Wednesday evening, has been started under direction of CLARENCE E. RINNE, chairman of the Professional Guidance Committee.

---

## FINLAND TECHNICAL INSTITUTE

An appeal is being made for books and scientific data to be sent to the Technical Institute, Teknillien Korkeakoulu, Finland, which was bombed and totally destroyed by the Russians during the War.

Dr. Martti Levon, director of the Institute, will welcome Scientific and Technical books and periodicals. In the remarkable efforts for recovery that the Finns are making, the lack of technical library facilities is a very serious handicap.

Material should be marked for the Institute of Technology, Helsinki, and sent to the Legation of Finland, 2144 Wyoming Avenue, N. E., Washington, D. C. Dr. K. T. Jutila, Finish Minister, will arrange for their being shipped to Finland.

---

## INSTITUTE OF AERONAUTICAL SCIENCES

The San Francisco Bay Area chapter of the Institute of Aeronautical Sciences held a recent meeting in Atherton, with Frank Fink, Chief Engineer of the Consolidated Vultee Aircraft Corporation as the principal speaker.

---

## UNIVERSITY BUILDING FUND

State funds totalling \$95,147,000 are now available for new construction on the eight campuses of the University of California.

This building fund consists of \$35,932,000 appropriated by the last California Legislature and \$59,215,000 made available by the State between 1941 and 1946.

Allocation of funds by campuses is as follows: Berkeley, \$17,380,000; Davis, \$8,150,000; La Jolla, \$502,000; Los Angeles, \$31,825,000; Mt. Hamilton, \$1,950,000; Riverside, \$765,000; San Francisco, \$21,465,000; and Santa Barbara, \$3,405,000. In addition, \$270,000 is available for improvements at the Meloland experiment station in Imperial County and \$6,600,000 for dormitory construction on the Berkeley, Davis, Los Angeles and Santa Barbara campuses.

---

## WELDING PATENTS

A classification system for the more than 11,000 welding patents in the Davis Welding Library at Ohio State University, Columbus, is being established under the direction of Dr. W. H. Simon, according to an announcement by Dean Charles E. MacQuigg of the College of Engineering.

The library includes a large collection of patents relating to the welding processes and their industrial application.

---

## MEDICAL BUILDING

A CPA permit has been granted for the construction of a \$35,000 Three-suite Medical Building at Antioch, California.

IVAN M. NELIDOV is serving as instructor in the Division of Engineering Extension, University of California in San Francisco in "Review of Civil Engineering," and "Advanced Analysis of Indeterminate Structures."

## TRACY PUMPING PLANT

Contractors have begun construction of the Tracy Pumping Plant of the Central (California) Valley Project, and have 960 days to complete the job at a cost of \$5,888,695.

It is the second largest of its type in the world.

## ORGANIZATION CHANGES



FREEMAN C. SCHARR

Bryant Electric Company, replaces Mr. Smoot as district manager of the Northwest.

L. A. Hobbs, vice president and sales manager of Smoot-Holman, Inglewood, California, has announced the transfer of C. E. Smoot, Jr., from Seattle to San Francisco as district manager of that area.

Freeman C. Scharr, formerly Pacific Coast district manager for the

## DRAWINGS STARTED

Concord, Calif., school district has authorized the starting of work on drawings for a new \$375,000 grammar school which will consist of 12 classrooms, an auditorium, cafeteria and kindergarten. Confer, Ponsford & Price of Oakland are the architects.

## ELECTRONICS

Advantages of the San Francisco area as a location for plants to produce electronic devices are covered in a special report, "The San Francisco Bay Region Electronics Industry." The report was submitted to the San Francisco Chamber of Commerce by George C. Tenney, chairman of the chamber's electronics section.

## ELMWOOD

A new \$250,000 grammar school is contemplated for Elmwood, Calif., near Stockton. It will have 17 classrooms, a cafeteria and craft room. Construction is to be of reinforced concrete with asphalt tile floors. Elmore G. Ernest of Stockton is the architect.

HARRIS CONSTRUCTION COMPANY, have been awarded contract for construction of 33 duplex residences, ten rooms each, at Fresno, California. Cost \$600,000.

## Thanks to my builder



## My home has convenient, built-in telephone outlets

By specifying that telephone conduit be installed during construction, little was added to building cost . . . real value was added to the house.



The location of the telephone can be changed or additional telephones added without drilling through the flooring or running wires along baseboards.

The convenience of well-placed telephone outlets will be appreciated for years to come.



Call or dial your local Telephone Business Office. Ask for Architects and Builders Service.

## The Pacific Telephone and Telegraph Co.



(From Page 9)

ton, plus a special showing of Guatemalan Textiles, October 1 to 31.

**SAN FRANCISCO MUSEUM OF ART**

The program of exhibitions and activities announced by Dr. Grace McCann Morley for October includes the following:

**EXHIBITIONS:** Photographs and Plan drawings by the Society of Industrial Designers, October 8 through November 2; Recent **PAINTINGS** and **SCULPTURES** by Bay Region Artists, October 7 through November 2; **MODERN ART in ADVERTISING**, October 8 through November 9.

**ACTIVITIES:** Invitation to Modern Art, four round table discussions and a house tour, each Thursday afternoon at 2:30 o'clock, October 9 through November 6; Four Lecture Demonstrations on **FLOWER ARRANGEMENT**, to be given by Madame Obata on Wednesday afternoons at 2:30 o'clock, October 8 through October 29; **ART IN CINEMA**, a five week film program of the Avant-garde, Friday evenings at 8 o'clock October 10 to October 31. There will be a Concert by The Berkeley Chamber Singers on Friday evening, 8:15 p.m., November 21.



"TWO COPS"

by Albin Templeman

Anonymous Donor Prize for Water Color in the open exhibition for Artist members, San Francisco Art Association, Showing at the DeYoung Memorial Museum October 4 to November 4.

FAMOUS FILM SERIES will continue each Tuesday evening at 8 o'clock; and the KNOW YOUR WORLD FILM SERIES, each Saturday and Sunday at 2:30.

**UNIVERSITY OF OREGON SCHOOL OF ARCHITECTURE**

Mark R. Sponenburgh, chairman of the exhibitions for the School of Architecture and Allied Arts, has announced the following schedule of Exhibitions for the fall and winter terms at the University of Oregon.

**FACULTY SHOW** of architecture, painting, sculpture and crafts, September 27 to October 5; **M. F. A. TERMINAL PROJECT** of Curtis and Sandgren, Oils and Watercolors, October 7 to 13; **SYRACUSE ANNUAL**, featuring Ceramics, October 27 to November 13; **SCALAMANDRE**, textiles, November 22 to December 4; **ARTS OF EARLY PEOPLE**, Anthropology Collection of the University of Oregon, January 10 to 29; **FRENCH PRINTS**, from

**FOR BETTER SERVICE**  
*Remember that*  
**KRAFTILE is**  
**WESTERN HEADQUARTERS**  
**FOR**

- ▶ GLAZED Structural Wall Units
- ▶ PATIO Tile
- ▶ QUARRY Tile
- ▶ SWIMMING POOL Overflow Gutter
- ▶ ACID Brick
- ▶ ACID-PROOF Jointing Compounds
- ▶ ACID-PROOF Floor and Tank Construction
- ▶ ACID-PROOF Coatings

**QUONSET** Packaged Steel Buildings    ▶ **STRAN-STEEL** Framing

For complete information and prompt service, phone or write

**KRAFTILE COMPANY**  
 NILES, CALIFORNIA    NILES 3611  
 SAN FRANCISCO: 50 Hawthorne Street — DOUGLAS 3780  
 LOS ANGELES: 316 E. Commercial Street — MUTUAL 2411



Corot to Picasso, consisting of Drawings, Etchings and Lithography, February 7 to 26; and ECKBO, ROYSTON and WILLIAMS exhibit of Landscape Architecture, March 6 to 20.

**CALIFORNIA SCHOOL OF FINE ARTS**

A special series of photographs of the Stanford University Campus, representing the results of a special assignment to members of the Photography Department of the School, will be on exhibit during October. Student instruction is under the guidance of Minor White.

**AMENDMENTS TO THE CALIFORNIA STATE HOUSING ACT**

(From Page 14)

who becomes aware of any fire or smouldering combustion of an unwarranted or insidious nature not confined within the equipment designed for fire or which is a hazard to the apartment house or hotel, not to report the matter without delay to the local fire department.

To compensate for the added fire protection to new apartment houses and hotels as set forth above there will be a reduction in the number of fire escapes and stairways required to the extent of 2000 square feet per floor.

The foregoing are the major changes to the State Housing Act. Several sections of the Law have been repealed and revised to fit in with the new requirements.

Some question has arisen as to the retroactive application of certain of these amendments and the matter is now before the Attorney General for an opinion.

The California State Housing Act, as amended, is one of the foremost statutes having to do with fire protection, safety, sanitation and maintenance of hotels and apartment houses. Copies of Chapter 1493, embodying the recent amendments may be secured from the Housing Division at either of its San Francisco, Los Angeles or Sacramento office.

The Housing Division, through the Department of Industrial Relations, intends to submit other constructive amendments at future Legislative sessions so as to maintain the law up to modern standards at all times. Such suggested amendments will be formulated in cooperation with enforcing officials and representatives of organizations and groups interested in housing so their proposals may be incorporated in the legislation.

EUREKA RESIDENCE designed by Architect Ernest F. Winkler, San Francisco, for Dr. and Mrs. Merced J. Wrigley will cost \$25,056 to build.

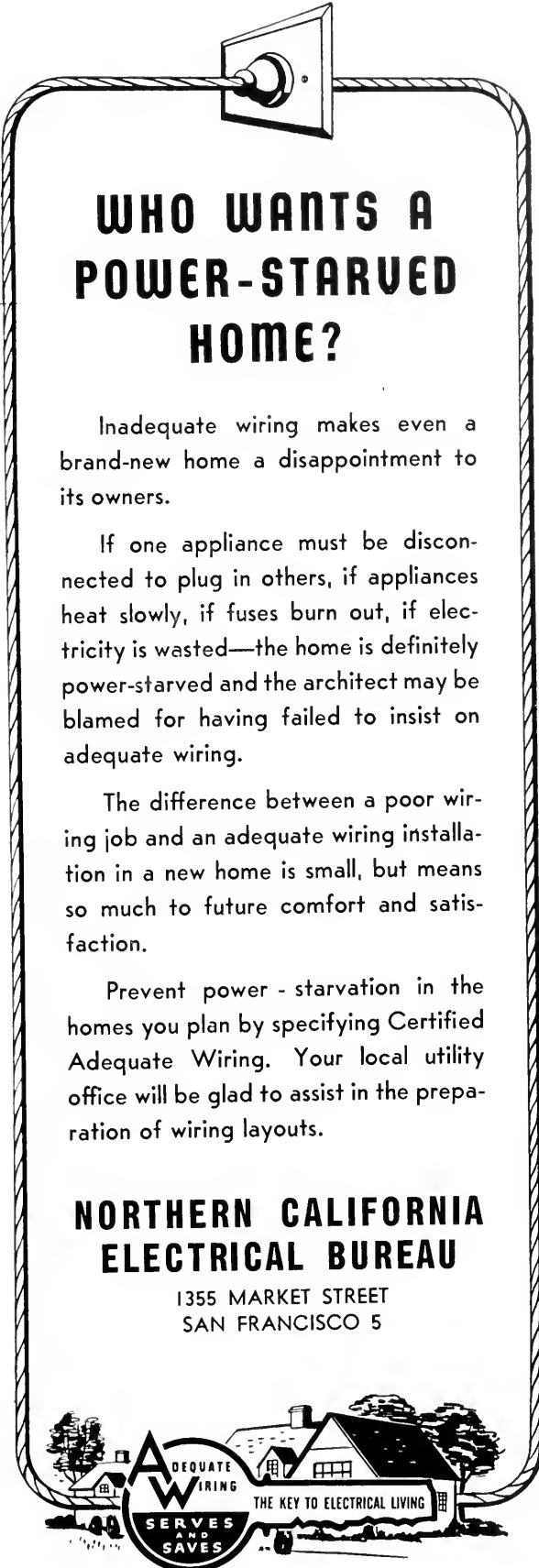

**WHO WANTS A POWER-STARVED HOME?**

Inadequate wiring makes even a brand-new home a disappointment to its owners.

If one appliance must be disconnected to plug in others, if appliances heat slowly, if fuses burn out, if electricity is wasted—the home is definitely power-starved and the architect may be blamed for having failed to insist on adequate wiring.

The difference between a poor wiring job and an adequate wiring installation in a new home is small, but means so much to future comfort and satisfaction.

Prevent power - starvation in the homes you plan by specifying Certified Adequate Wiring. Your local utility office will be glad to assist in the preparation of wiring layouts.

**NORTHERN CALIFORNIA ELECTRICAL BUREAU**  
 1355 MARKET STREET  
 SAN FRANCISCO 5

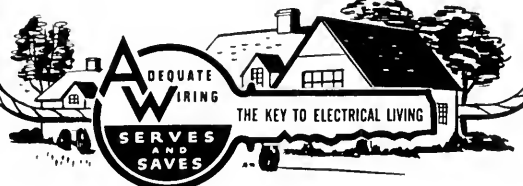

By E. H. W.



## E. K. WOOD LUMBER CO.

**SAN FRANCISCO** General Offices: No. 1 Drumm Street  
**LOS ANGELES** Office and Yards: 4710 S. Alameda St. — JE 3111  
**OAKLAND** Yards and Wharves: 2111 Frederick St. — KE 24277  
**PORTLAND** Mill Sales Office: 827 Terminal Sales Bldg.

**SAW MILLS:** Roseburg, Oregon • Reedsport, Oregon

**RETAIL YARDS:** LOS ANGELES • OAKLAND • ONTARIO • HOLLYWOOD  
 LONG BEACH • RIVERSIDE • TEMPLE CITY • SIERRA MADRE • INDIO • THERMAL  
 LA VERNE • WHITTIER • PASADENA • SAN PEDRO

"Federal bureaucracy is the most powerful and potentially the most dangerous lobby of all . . ." —Christian Herter, Congressman from Massachusetts.

\*\*\*

According to recent surveys predictions of substantial declines in construction costs are unfounded. High labor costs and high materials preclude the possibility of any immediate reduction in general construction costs.

\*\*\*

Good Housekeeping magazine is offering \$500 to any architect whose house is published in their nationwide contest "Homes America Wants." . . . E. H. W., being American, wants a home too.

\*\*\*

"An analysis of budgets submitted to legislatures of 24 states in the early months of this year shows that, almost without exception, greater expenditures are proposed." —U. S. Census Bureau.

\*\*\*

"I would like the record (Congressional) to reflect that we were very favorably impressed with many of the local Housing Authority operations. Such places as Phoenix, Fort Worth, New Orleans, Cleveland and San Francisco . . . presented an operation that was a real credit to the community." —Robert E. L., FBI, testifying before a House Subcommittee.

\*\*\*

Americans received \$169-billion last year as income from all sources.—U. S. Department of Commerce.

\*\*\*

More than 4650 new factories and major plant expansions, representing private capital investments of some \$700-million, have been started, or completed in California during the past two and one half years.

\*\*\*

Cities should "pitch in" and work out their slum clearance problems on a community level, using private enterprise methods.—Edward R. Carr, President, National Ass'n of Home Builders.

\*\*\*

"The widest possible development and use of such tools of management as interchangeability of parts, standard components, precise units of length, weight, color and visibility are the very key to national progress."—Brig. General Donald Armstrong, speaking before the American Standards Association.



**PRESSURE TREATED LUMBER**  
 ● **PROTECTS AGAINST DECAY**  
**AND TERMITE ATTACK**

*Specify it in your home*  
*Available through Lumber Dealers*

LOS ANGELES  
 601 W. 5th Street  
 Phone MIchigan 6294

SAN FRANCISCO  
 333 Montgomery Street  
 Phone DOuglas 2-3883

## J. H. Baxter & Co.

AGENTS FOR WEST COAST WOOD PRESERVING CO. SEATTLE, WASH

## IN THE NEWS

### NEWSPAPER BUILDING

The Daily Californian at Salinas has awarded a contract for the construction of a new \$300,000 newspaper building. Eugene T. Denham, Columbus, Ohio, and Chas E. Butner, Salinas are the Architects.

### BANK BUILDING

The First National Bank of San Jose, California, have awarded a contract to E. A. Hathaway Company of the same city, for the construction of a \$100,000 branch bank building in Santa Clara County.

### HOME TYPE WATER FILTER

Particularly suitable for homes the new W-8 filter, manufactured by the SPARKLER MANUFACTURING Company, Mundelein, Ill., measures 6 by 9 inches and has a flow rate of 60 gal. per hr.

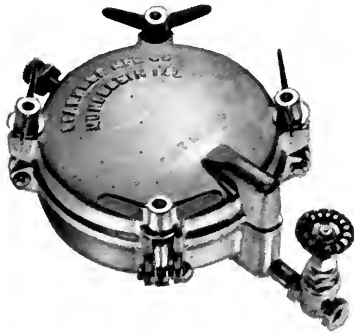

Easy to install at kitchen, or utility sink, and delivers filtered water through auxiliary faucet. Removes off-tast and odors in water, as well as chlorine, algae, sediment and pipe rust. Available through plumbing trade.

### CHURCH ADDITION

A CPA permit has been granted for a \$36,500 addition to the Trinity Methodist Church in Chico, California.

### PACIFIC PIPE

Barritt & Hilp have been awarded contract for remodeling the Pacific Pipe Company's San Francisco plant.

### SCHLAGE LOCK COMPANY

A CPA permit has been granted for \$90,000 addition to the Schlage Lock Company plant in San Francisco.

# The West's Outstanding Lighting Equipment

Users know from experience that the Smoot-Holman label is an assurance of quality. Look for it whenever you select lighting equipment, and be assured of outstanding service and trouble-free performance.

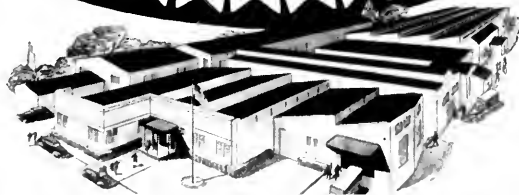

Offices in Principal Western Cities—Branch and Warehouse in San Francisco

# LANDSCAPE ARCHITECTURE

## Notes of The Profession

---

ASSOCIATION OF LANDSCAPE ARCHITECTS, SAN FRANCISCO REGION

Vernon Dean, President; Robert Royston, Vice-President; Ned Rucker, Treasurer;  
E. L. Anderson, Secretary, 1736 Franklin, Oakland, California.

---

### APPOINTED

Edwin G. Thurlow, Head of the Department of Landscape Architecture, North Carolina State College of Agriculture and Engineering, recently announced the appointment of Lawrence A. Enerson as Professor of Landscape Architecture.

Prof. Enerson taught Landscape Architecture at the University of Michigan and the Graduate School of Design of Harvard University prior to practicing Architecture and Site Planning in Lincoln, Nebraska.

---

### GOLDEN GATE FIELD

The office of **William P. Mott, Litton and Whitney**, have completed the work on the recently opened Golden Gate Field, horse racing track at Albany, California, for the Pacific Turf Club, Inc.

Included in the project was preparation of a Master Plan, a Plan Study, Working Drawings, and specifications for the Grandstand Entrances, Perimeter Planting and the Infield Planting.

\* \* \*

The firm is also doing the landscaping of Thrasher Park in San Leandro, California, which includes area surrounding a large swimming pool, a sun terrace, a special development for younger children and a baseball park.

---

THE WILLIAM P. MOTT office has announced the extensive landscaping of an area for the Presbyterian Conference Ground at the Pacific Palisades in southern California.

---

ACROSS THE GOLDEN GATE BRIDGE in Marvellous Marin County, **Katy and Paul Steinmetz** are very busy on their newest project, that of landscaping a specialized Shopping Center in Corte Madera, California.

---

ANOTHER OFFICE which is humming with activity is that of **Thomas D. Church** where several large landscape projects are under way. Notable among them is the site planning of a shopping center in Beverly, Massachusetts; the new Richmond Chase Canning Company Plant at San Jose, California; and of great interest to the pro-

fession because of its position in national affairs, is the work being done with the Architect in connection with the development of the new Del Monte Properties Company at Del Monte, California.

---

### PAN AMERICAN CONFERENCE EXHIBIT

Through the fine cooperation of its members the American Landscape Association has assembled an exhibit of the work of A.L.A. members which will be shown at the Pan American Conference of Architects in Lima, Peru.

The Conference, scheduled for October, will bring together outstanding Architects and allied professions in what promises to be one of the finest gatherings ever held.

---

MACK HALLAWER is now employed by the Island Engineers who are engaged in the design of numerous interesting projects on Guam and other Pacific islands. Offices of the Company are located in the Ferry Building, San Francisco.

---

### U. C. DEPARTMENT OF LANDSCAPE DESIGN

The Fall enrollment in the University of California, Department of Landscape Design, at Berkeley has been so large that numerous revisions have had to be made in the Department to meet the current needs.

---

### PLEASANTON

The taxpayers of the Pleasanton, Calif., school district have voted favorably on a \$130,000 bond issue for the building of a 10-classroom grammar school addition. The architect will be Ralph N. Kerr of San Leandro.

---

### RENO HOSPITAL

Architects DeLongchamps & O'Brien of Reno, Nevada, are working on drawings for an addition to the Washoe County Hospital. Plans call for a 4 story brick and reinforced concrete and steel building to cost \$1,500,000.

---

# COMEDY IN PROFESSIONAL PRACTICE

By **ELMER GREY, Architect**

We'll call his name Woodbury, but all the rest is exactly true to facts. His financial interests were in Mexican gold mines and one day he came into the office and started telling me how he wanted the front of a house to look like one that he contemplated building down there. He went into considerable detail about it and every time I made an attempt to discuss the plan back of the architectural front he would head me off with an interruption—and revert back to the front. Finally I interrupted him and said, "But Mr. Woodbury, don't you think that before we go any further we ought to discuss somewhat, at least, a tentative plan?" "Oh no," he said, "you don't understand. I've got a lot of Mexicans down there that I've got to keep busy to keep them out of mischief; and all I want to build now is the front wall of a house—and later on, perhaps I'll build the rest behind it!"

On another day he was conducting me around Los Angeles for some reason or other and took me into an old wooden house that he owned over the Broadway tunnel. It was used at the time as the office of a moving picture company. As you came into the hall a staircase wound around three sides of it, and in the middle was some enormous object, all covered up with what looked like bed sheets sewed together.

I said, "For Heaven's sake, Mr. Woodbury, what have you got here?" "Well, that's quite a story," he said. "Many years ago my father went to Rome, and in the Vatican Museum saw a statue known as the Apollo Belvedere. He admired it so much that he had an exact duplicate made of it out of Carrara marble. When he got it over here he didn't know what to do with it so put in in this old house. It cost him \$20,000. There is a fine

pedestal that belongs to it out under the street. When the street was re-graded it was covered up and you can see only about three inches of it now sticking above the ground in the parking."

I said, "But Mr. Woodbury, why have you got this valuable statue all covered up with bed sheets?" "Oh, why some of the girls working for this moving picture company thought it was indecent," he explained, "so we got a lot of bed sheets, had them sewed together, and covered it up!"

My brain began to work at the double-quick and finally I said, "Mr. Woodbury, this work of art doesn't do anybody any good here. Would you be willing to make an indefinite loan of it to

## TERRAZZO

for Floors and Wainscoting in Hospitals, Theaters, Hotels,  
Office Buildings, Schools and Stores.

**DECORATIVE • DURABLE • SANITARY**



### FOX TILE CO.

3247 E. 14th Street, Oakland  
Phone: ANdover 1-0431

## RAMONA TILE

A Complete Line of  
**INTERIOR and EXTERIOR TILES**  
For Floor and Wall

Durability and Beauty Throughout the Years

**PACIFIC TILE & PORCELAIN CO.**

Office and Display Rooms  
1270 West Olive Street  
Hynes, California

Telephones: NEvada 6-1477—MEtcalfe 3-1195



.IN PUBLIC BUILDINGS



.IN SCHOOLS



.IN HOSPITALS

...the logical specification



In office buildings in major cities throughout the country, in the nation's important hospitals, in public and parochial schools from coast to coast . . . and in thousands of industrial plants, too . . . you'll find Halsey Taylor Drinking Fountains the logical installations.

Patented health-promoting, trouble-proof features make them easily the most hygienic fountains you can specify! Get our latest catalog.

**THE HALSEY W. TAYLOR CO.**  
WARREN, O.  
West Coast Plant, Redlands, Calif.



Halsey-Taylor

DRINKING FOUNTAINS

## STRUCTURAL STEEL

For Class A Buildings,  
Bridges, etc.

**JUDSON PACIFIC - MURPHY CORP.**

4300 EASTSHORE HIGHWAY  
EMERYVILLE, CALIF.

## FORDERER CORNICE WORKS

*Manufacturers of*

Hollow Metal Products • Interior Metal Trim  
Elevator Fronts and Cabs  
Metal Plaster Accessories • Sanitary Metal Base  
Flat and Roll Metal Screens  
Metal Cabinets • Commercial Refrigerators

**269 POTRERO AVE.**

**SAN FRANCISCO, CALIF.**

**HEMLOCK 4100**

## VALUABLE NEWS SERVICE

- BUILDING MATERIAL DEALERS
- CONTRACTORS
- ENGINEERS
- FINANCIAL INSTITUTIONS

**ARCHITECTS REPORTS** gives advance news on construction projects in Northern California, lists: name of projects, location, architect, proposed cost and other pertinent information.

**HANDY** individual slip-reports, issued daily at a total cost of only

\$10 a month

## ARCHITECT'S REPORTS

Published Daily

The **ARCHITECT and ENGINEER, Inc.**

68 Post Street, San Francisco - DO 8311

the California Institute of Technology if I raised the money to move it?" He thought a moment and then said, "Yes, I would do that." So I interviewed the directors of the Institute, found that they would be glad to get it, raised the money for moving it (\$100) by \$10 subscriptions—and it has been over at the California Institute of Technology ever since.

### WAR DEVELOPED HIGH TENSILE STEEL NOW USED IN STRAN-STEEL

A fifty per cent increase in strength and greatly increased resistance to corrosion on arch rib framing members in "Quonset" packaged steel buildings has been achieved through use of a war-developed high tensile alloy steel, according to C. W. Kraft of the Kraftile Company local distributors for the Stran-Steel Division of the Great Lakes Steel Corporation, Detroit.

Known as "N-A-X High Tensile," the alloy was developed for armor plate use during the war, and exhibits high resistance to impact, flexing fatigue, corrosion and abrasion.

### LECTURE COURSE

"Introduction to City and Regional Planning" is the subject of a course offered by the University of California Extension. Los Angeles.

The 15 weekly lectures will be given at 813 S. Hill Street under the direction of Charles B. Bennett, Director of Planning for Los Angeles.

### COLMAN NAMED ASSISTANT

C. J. Colman, has been appointed General Assistant to Vice President of A. J. Stream, Plant Rubber and Asbestos Works, San Francisco.

He has been associated with Plant Rubber for more than 18 years.

FRANK BURNS, has been appointed Public Relations Representative of Columbia Steel Company for Southern California, Arizona, and Southern Nevada, with offices in Los Angeles.

### ARCHITECTS' CERTIFICATES

(From Page 31)

John W. Kruse, Daly City; Lawrence B. Lackey, Atherton; Roger Y. Lee, John A. Zerkle and Raymond S. Ziegler, Berkeley; Allyn C. Martin, Richmond; William F. Meaney and Donald E. Olson, Oakland; Delmar S. Mitchell and Richard G. Wheeler, San Diego; Alfred C. Prescott, Burbank; Albert A. Richards, Montebello; Benton E. Urmston, Sherman Oaks; David A. Wallace, Jr., Hollywood; Allan S. Watts, Hayward; Pierre Woodman, Ontario; and Joseph F. Thomas, Riverside.

A certificate was also granted to Edward H. DeWolf of Reno, Nevada.

# ESTIMATOR'S GUIDE

## BUILDING AND CONSTRUCTION MATERIALS

PRICES GIVEN ARE FIGURING PRICES AND ARE MADE UP FROM AVERAGE QUOTATIONS FURNISHED BY MATERIAL HOUSES TO SAN FRANCISCO CONTRACTORS. 2½% SALES TAX ON ALL MATERIALS BUT NOT LABOR

All prices and wages quoted are for San Francisco and the Bay District. There may be slight fluctuation of prices in the interior and southern part of the state. Freight cartage, at least, must be added in figuring country work.

**BONDS**—Performance—\$10 per \$1000 of contract. Labor and materials, \$10 per \$1000 of contract.

**BRICKWORK**—

- Common Brick—Per 1M laid—\$80.00 to \$100.00 (according to class of work).
- Face Brick—Per 1M laid—\$150 to \$200 (according to class of work).
- Brick Steps—\$2.30 per lin. ft.
- Brick Veneer on Frame Bldg.—Approx. \$1.50 per sq. ft.
- Common Brick—\$26.00 per M, truckload lots, f.o.b. job.
- Face Brick—\$60 to \$100 per M, truckload lots, delivered.
- Cartage—Approx. \$5.00 per M.

**BUILDING PAPER**—

- 1 ply per 1000 ft. roll.....\$5.30
- 2 ply per 1000 ft. roll.....7.80
- 3 ply per 1000 ft. roll.....9.70
- Brownskin, Standard, 500 ft. roll.....7.00

**BUILDING HARDWARE**—

- Sash cord com. No. 7.....\$2.65 per 100 ft.
- Sash cord com. No. 8.....3.00 per 100 ft.
- Sash cord spot No. 7.....3.65 per 100 ft.
- Sash cord spot No. 8.....4.00 per 100 ft.
- Sash weights, cast iron, \$75.00 ton.
- Nails, \$3.42 base.

**CONCRETE AGGREGATES**—

The following prices net to Contractors unless otherwise shown. Carload lots only.

	Bunker per ton	Del'd per ton
Gravel, all sizes .....	\$2.44	\$2.75
Top Sand .....	2.38	3.13
Concrete Mix .....	2.38	3.06
Crushed Rock, ¼" to ¾".....	2.38	2.94

	Bunker per ton	Del'd per ton
Crushed Rock, ¾" to 1½".....	\$2.38	\$3.13
Roofing Gravel .....	2.81	3.50
River Sand .....	2.50	3.06

**Sand**—

Lapis (Nos. 2 & 4).....	3.56	3.94
Olympia (Nos. 1 & 2).....	3.56	3.88

**Cement**—  
Common (all brands, paper sacks), carload lots, \$3.02 per bbl. f.o.b. car; delivered \$3.40.  
Cash discount on carload lots, 10c a bbl., 10th Prox., less than carload lots \$4.00 per bbl. f.o.b. warehouse or delivered.  
Cash discount 2% on L.C.L.

Atlas White	1 to 100 sacks, \$3.13 sack warehouse or del.; \$9.56 bbl. carload lots.
Calaveras White	
Medusa White	

**DAMPPOOFING and Waterproofing**—

- Two-coat work, \$5.00 per square.
- Membrane waterproofing—4 layers of saturated felt, \$9.00 per square.
- Hot coating work, \$3.00 per square.
- Medusa Waterproofing, \$3.50 per lb. San Francisco Warehouse.
- Tricocel waterproofing.  
(See representative.)

**ELECTRIC WIRING**—\$15 to \$20 per outlet for conduit work (including switches).

Knob and tube average \$6.00 per outlet. (Available only for priority work.)

**ELEVATORS**—

Prices vary according to capacity, speed and type. Consult elevator companies. Average cost of installing a slow speed automatic passenger elevator in small four story apartment building, including entrance doors, about \$8000.00.

**EXCAVATION**—

- Sand, \$1.00; clay or shale, \$1.50 per yard.
- Trucks, \$30 to \$45 per day.
- Above figures are an average without water. Steam shovel work in large quantities, less; hard material, such as rock, will run considerably more.

**FIRE ESCAPES**—

Ten-foot galvanized iron balcony, with stairs, \$250 installed on new buildings; \$300 on old buildings.

**FLOORS**—

- Composition Floors, such as Magnesite, 50c per square foot.
- Linoflor—2 gages—\$3.00 per sq. yd.
- Mastipave—\$1.50 per sq. yd.
- Battleship Linoleum—available to Army and Navy only—1/8"—\$3.50 sq. yd.  
3/16"—\$3.50 sq. yd.
- Terazzo Floors—\$1.50 per sq. ft.
- Terazzo Steps—\$2.50 per lin. ft.
- Mastic Wear Coat—according to type—20c to 35c.

**Hardwood Flooring**—

- Standard Mill grades not available.
- Victory Oak—T & G
- ¾" x 2¼".....\$252.00 per M. plus Cartage
- ½" x 2".....\$210.00
- ½" x 1½".....200.00
- Prefinished Standard & Better Oak Flooring
- ¾" x 3¼".....\$265.00 per M. plus Cartage
- ½" x 2½".....237.00 per M. plus Cartage
- Maple Flooring
- ¾" T & G Clear \$330.00 per M. plus Ctg.
- 2nd 305.00 per M. plus Ctg.
- 3rd 255.00 per M. plus Ctg.
- Floor Layers' Wage, \$2.12½ per hr. (Legal as of July 1, 1947. Given us by Inlaid Floor Co.)

**GLASS**—

- Single Strength Window Glass.....\$ .40 per □ ft.
- Double Strength Window Glass......60 per □ ft.
- Plate Glass, under 75 sq. ft.....1.25 per □ ft.
- Polished Wire Plate Glass.....2.10 per □ ft.
- Rgh. Wire Glass......60 per □ ft.
- Obscure Glass......40 per □ ft.
- Glazing of above is additional.
- Glass Blocks.....\$2.75 per □ ft. set in place

**HEATING**—

- Average, \$2.50 to \$3.00 per sq. ft. of radiation, according to conditions.
- Warm air (gravity) average \$64 per register.
- Forced air average \$91 per register.

**INSULATION AND WALLBOARD—**

Rockwool Insulation— (2")	\$65.00 per M sq. ft.
Cotton Insulation—Full-thickness (3½")	\$95.50 per M sq. ft.
Aluminum Insulation—Foil-mounted on both sides	\$33.50 per M sq. ft.
Tileboard—4'x6' panel	\$9.00 per panel
Wallboard—½" thickness	\$49.50 per M sq. ft.
Finished Plank	\$69.00 per M sq. ft.
Ceiling Tileboard	\$69.00 per M sq. ft.

**IRON**—Cost of ornamental iron, cast iron, etc., depends on designs.

**LUMBER—**

No. 1 Common	\$90.00 per M
No. 2 Common	88.00 per M
Select O. P. Common	94.00 per M
<b>Flooring—</b>	
	Per M Delvd.
V.G.-D.F. 8 & 8tr, 1 x 4 T & G Flooring	\$170.00
"C" and better—all	170.00
"D" and better—all	170.00
Rwd. Rustic—"A" grade, medium dry	150.00
8 to 24 ft.	
"B" grade, medium dry	150.00
<b>Plywood</b>	
	15c to 18c per ft.
Plyscord	9½c per ft.
Plywall	9c per ft.
Plyform	15c per ft.
<b>Shingles (Rwd. not available)—</b>	
Red Cedar No. 1	\$13.00 per square; No. 2, \$10.50; No. 3, \$9.00.
Average cost to lay shingles	\$6.00 per square.
Cedar Shakes—Tapered: ½" to ¾" x 25"	\$17.00 per square.
Resawn ¾" to 1¼" x 25"	\$22.00 per square
Average cost to lay shakes	8.00 per square

**MILLWORK—Standard.**

D. F. \$150 per 1000. R. W. Rustic \$175 per 1000 (delivered).  
 Double hung box window frames, average with trim, \$12.50 and up, each.  
 Complete door unit, \$15 to \$25.  
 Screen doors, \$6.00 to \$8.00 each.  
 Patent screen windows, \$1.25 a sq. ft.  
 Cases for kitchen pantries seven ft. high, per lineal ft., \$12.00 each.  
 Dining room cases, \$15.00 per lineal foot.  
 Rough and finish about \$1.00 per sq. ft.  
 Labor—Rough carpentry, warehouse heavy framing (average), \$60.00 per M.  
 For smaller work average, \$60.00 to \$75.00 per 1000.

**MARBLE—(See Dealers)**

**PAINTING—**

Two-coat work .....per yard 60c  
 Three-coat work .....per yard 80c  
 Cold water painting .....per yard 25c  
 Whitewashing .....per yard 15c  
 Turpentine..... \$1.85 per gal. in 5-gal. cont.  
 Raw Linseed  
 Oil.....\$3.33 per gal. in 5-gal. cont.

Boiled Linseed  
 Oil ..... \$3.23 per gal. in drums.  
 Boiled Linseed Oil—\$3.33 per gal. in 5-gal. containers.  
 Replacement Oil—\$2.75 per gal. in drums.  
 \$2.75 per gal. in 5-gal. containers.  
 Use Replacement  
 Oil.....\$3.00 per gal. in 1 gal. cont.  
 A deposit of \$7.50 required on all drums.

**PATENT CHIMNEYS—**

6-inch	\$2.00 lineal foot
8-inch	2.50 lineal foot
10-inch	3.50 lineal foot
12-inch	4.50 lineal foot

**PLASTER—**

Neat wall, per ton delivered in S. F. in paper bags, \$17.60.

**PLASTERING (Interior)—**

3 Coats, metal lath and plaster	Yard \$3.00
Keene cement on metal lath	3.50
Ceilings with ¾ hot roll channels metal lath (lathed only)	3.00
Ceilings with ¾ hot roll channels metal lath plastered	4.50
Single partition ¾ channel lath 1 side (lath only)	3.00
Single partition ¾ channel lath 2 inches thick plastered	8.00
4-inch double partition ¾ channel lath 2 sides (lath only)	5.75
4-inch double partition ¾ channel lath 2 sides plastered	8.75
Thermax single partition; 1" channels; 2¼" overall partition width. Plastered both sides	7.50
Thermax double partition; 1" channels; 4¾" overall partition width. Plastered both sides	11.00
3 Coats over 1" Thermax nailed to one side wood studs or joists	4.50
3 Coats over 1" Thermax suspended to one side wood studs with spring sound isolation clip	5.00
Note—Channel lath controlled by limitation orders.	

**PLASTERING (Exterior)—**

2 coats cement finish, brick or concrete wall	Yard \$2.50
3 coats cement finish, No. 18 gauge wire mesh	3.50
Lime—\$4.00 per bbl. at yard.	
Processed LLime—\$4.15 per bbl. at yard.	
Rock or Grip Lath—¾"—30c per sq. yd.	
¾"—29c per sq. yd.	
Composition Stucco—\$4.00 sq. yard (applied).	

**PLUMBING—**

From \$150.00 per fixture up, according to grade, quality and runs.

**ROOFING—**

"Standard" tar and gravel, 4 ply—\$11.00 per sq. for 30 sqs. or over.  
 Less than 30 sqs. \$14.00 per sq.  
 Tile \$40.00 to \$50.00 per square.  
 Redwood Shingles, \$15.00 per square in place.  
 5/2 # 1-16" Cedar Shingles, 4½"  
 Exposure .....\$16.50 square

5/8 x 16"—# 1 Cedar Shingles, 5"  
 Exposure ..... \$17.00 square  
 4/2 # 1-24" Royal Shingles, 7½"  
 Exposure ..... \$18.25 square  
 Re-coat with Gravel \$5.50 per sq.  
 Asbestos Shingles \$30 to \$60 per sq. laid.  
 1/2 x 25" Resawn Cedar Shakes,  
 10" Exposure ..... \$18.50  
 3/4 x 25" Resawn Cedar Shakes,  
 10" Exposure ..... 21.00  
 1 x 25" Resawn Cedar Shakes,  
 10" Exposure ..... 22.00  
 Above prices are for shakes in place.

**SHEET METAL—**

Windows—Metal, \$2.50 a sq. ft.  
 Fire doors (average), including hardware \$2.80 per sq. ft.

**SKYLIGHTS—(not glazed)**

Copper, \$1.25 sq. ft. (flat).  
 Galvanized iron, 65c sq. ft. (flat).  
 Vented hip skylights 90c sq. ft.

**STEEL—STRUCTURAL—**

\$220 per ton erected, when out of mill.  
 \$270 per ton erected, when out of stock.

**STEEL REINFORCING—**

\$150 to \$170 per ton, in place.

**STORE FRONTS (None available).**

**TILE—**

Ceramic Tile Floors—\$1.50 per sq. ft.  
 Cove Base—\$1.25 per lin. ft.  
 Glazed Tile Wainscot—\$1.50 per sq. ft.  
 Asphalt Tile Floor ½" x ¾"—\$ .40 per sq. ft.  
 Light shades slightly higher.  
 Cork Tile—\$1.00 per sq. ft.  
 Mosaic Floors—See dealers.  
 Lino-Tile—\$1.00 per sq. ft.

**Wall Tile—**

Glazed Terra Cotta Wall Units (single faced) laid in place—approximate prices:

2 x 6 x 12	\$1.25 sq. ft.
4 x 6 x 12	1.50 sq. ft.
2 x 8 x 16	1.45 sq. ft.
4 x 8 x 16	1.75 sq. ft.

**VENETIAN BLINDS—**

75c per square foot and up. Installation extra.

**WINDOWS—STEEL—**

50c per square foot, \$5 for ventilators.



# IN THE NEWS

## NEW OUTLET

Completely fool-proof twin outlet; prohibits wires, hairpins, scissors or other foreign objects from being inserted in slots.

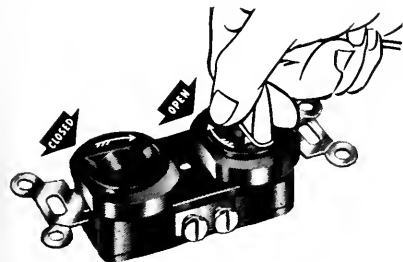

To connect simply insert plug of rotary cap and give plug a quarter turn to right, and push in plug.

NO-SHOK is available in brown or ivory, fits all standard outlet covers. Manufactured by BELL ELECTRIC Company, Chicago 8, Ill.

## RENAMED CHAIRMAN

Edward C. Huerkamp, sales manager of the Lighting Division of the Westinghouse Electric Corporation, has been named chairman of the Second International Lighting Exposition and Conference, scheduled for November 3rd to 7th in Chicago.

## FATALLY INJURED

Harry A. Schary, A.I.A., Architect, was fatally injured when his automobile was struck by a Key System bus at the corner of College Avenue and Woolsey Street in Berkeley, California, on October 5th.

# 3 IN 1-KIMSUL

INSULATION  
COLD • HEAT • SOUND  
PERFECTLY CONTROLLED

TREATED AGAINST FIRE, MOISTURE, VERMIN AND INSECTS. ECONOMICAL, LIGHT, EASY TO HANDLE AND INSTALL.

**GUNN CARLE & CO**  
20 POTRERO AVENUE • SAN FRANCISCO, CALIF.

## BUILDING TRADES WAGE (JOB SITES) NORTHERN AND CENTRAL CALIFORNIA

ATTENTION: The following are the PREVAILING hourly rates of compensation as determined by the Wage Adjustment Board, or which have been determined by the United States Department of Labor—Revised to July 1, 1946. Wage scales shown are those being paid and in effect mostly by agreement between employees and their union.

CRAFT	San Francisco	Alameda and Contra Costa	Marin	Vallejo	San Mateo	San Jose	Stockton	Sacramento	Fresno
	ASBESTOS WORKERS	1.75	1.75	1.75	1.75	1.75	1.75	1.75	1.75
BRICKLAYERS	2.05	2.05	2.05	2.05	2.05	2.05	1.75	2.05	2.00
BRICKLAYERS, HODCARRIERS	1.57½	1.57½	1.57½	1.57½	1.57½	1.42½	1.50	1.50	1.50
CARPENTERS	1.75	1.75	1.75	1.75	1.75	1.75	1.75	1.75	1.75
CEMENT FINISHERS	1.75	1.75	1.75	1.75	1.75	1.75	1.75	1.75	1.75
ELECTRICIANS	1.87½	1.87½	1.87½	1.70	1.87½	1.87½	1.75	1.82½	1.75
ENGINEERS: MATERIAL HOIST	1.60	1.60	1.60	1.60	1.60	1.60	1.60	1.60	1.60
PILE DRIVER	2.00	2.00	2.00	2.00	2.00	2.00	2.00	2.00	2.00
STRUCTURAL STEEL	2.00	2.00	2.00	2.00	2.00	2.00	2.00	2.00	2.00
GLASS WORKERS	1.58½	1.58½	1.58½	1.58½	1.58½	1.21	1.40	1.37½	1.37½
IRONWORKERS: ORNAMENTAL	1.85	1.85	1.85	1.85	1.85	1.85	1.85	1.85	1.85
REINF. RODMEN	1.75	1.75	1.75	1.75	1.75	1.75	1.75	1.75	1.75
STRUCTURAL	2.00	2.00	2.00	2.00	2.00	2.00	2.00	2.00	2.00
LABORERS: BUILDING & CONCRETE	1.25	1.25	1.15	1.15	1.15	1.15	1.25	1.25	1.15
LATHERS	1.90	1.90	1.60	1.87½	1.75	2.00	1.87½	1.60	1.87½
MARBLE SETTERS	1.75	1.75	1.75	1.75	1.75	1.75	1.75	1.75	1.75
MOSAIC & TERRAZZO	1.75	1.75	1.75	1.75	1.75	1.75	1.60	1.40	1.13½
PAINTERS	1.75	1.75	1.75	1.64	1.75	1.75	1.60	1.60	1.50
PILEDRIVERS	1.86	1.86	1.86	1.86	1.86	1.86	1.86	1.86	1.86
PLASTERERS	2.00	2.00	1.75	2.00	2.05	2.00	2.00	1.87½	1.87½
PLASTERERS' HODCARRIERS	1.75	1.75	1.75	1.75	1.75	1.75	1.65	1.65	1.40
PLUMBERS	1.87½	1.87½	1.87½	1.87½	1.87½	1.87½	1.87½	1.87½	1.87½
ROOFERS	1.50	1.62½	1.50	1.62½	1.25	1.37½	1.50	1.50	1.50
SHEET METAL WORKERS	1.75	1.75	1.75	1.75	1.75	1.75	1.75	1.75	1.75
SPRINKLER FITTERS	1.58	1.58	1.58	1.58	1.58	1.58	1.58	1.58	1.58
STEAMFITTERS	1.87½	1.87½	1.87½	1.87½	1.87½	1.87½	1.87½	1.87½	1.87½
STONESETTERS (MASON'S)	2.05	2.05	2.05	2.05	2.05	2.05	1.75	2.05	2.00
TILESETTERS	1.80	1.75	1.75	1.75	1.75	1.75	1.37½	1.37½	1.37½

Prepared and compiled by

CENTRAL CALIFORNIA CHAPTER, ASSOCIATED GENERAL CONTRACTORS OF AMERICA

with the assistance and cooperation of secretaries of General Contractors Associations and Builders Exchanges of Northern California

# CLASSIFIED ADVERTISING

RATE: 10c PER WORD . . . CASH WITH ORDER

MINIMUM \$2.50

**ARCHITECT'S REPORTS**—A valuable advance news service giving building and construction information daily on projects in Northern California. Name, location, architect, proposed cost, etc., on individual slips. Ideal for securing new business leads. Hundreds of items, total monthly cost only \$10. Don't delay, subscribe today. ARCHITECT & ENGINEER, Room 618, 68 Post Street, San Francisco, California. Phone DOUGLAS 2-8311.

**PHOTOGRAPHS:** Specializing in building and construction photographs for publication, or historic records. For Industrial-Aerial-Publicity photography use the INDUSTRIAL PHOTO'S, Room 722, Hearst Bldg., San Francisco, Phone SUTTER 1-6953.

**METAL WINDOWS** (Steel - Aluminum - Bronze). Large Stock, ALL TYPES. STEEL SASH SALES & SERVICE, Weehawken, N. J.

**ENGRAVING**—Good engravings are essential to a satisfactory job of printing reproduction. For the best, see Poor Richard Photo Engraving Co., 324 Commercial St., San Francisco.

**CLINTON  
CONSTRUCTION CO.  
OF CALIFORNIA**

**General Contractors**

923 FOLSOM STREET • SAN FRANCISCO

SUtter 1-3440

**HOGAN LUMBER CO.**

*Wholesale and Retail*

**LUMBER**

**MILL WORK • SASH & DOORS**

*Office, Mill, Yard and Docks*

SECOND AND ALICE STREETS • OAKLAND, CALIF.

Telephone GLencourt 1-6861

**SISALKRAFT**

REG. U. S. PAT. OFF.

*"More than a building paper"*

**THE SISALKRAFT CO.**

205 West Wacker Drive  
Chicago, Ill.

55 New Montgomery Street  
San Francisco, Calif.

**SANTA MARIA INN**

**SANTA MARIA, CALIFORNIA**

FRANK J. McCOY, General Manager

FERNAND E. PIMENTEL, Manager

On the  
Coast  
Highway  
between  
San  
Francisco  
and  
Los  
Angeles



American  
or  
European  
Plan  
•  
Old  
English  
Tap  
Room

**A CONTEMPORARY STORE**

(From Page 17)

some with sliding glass doors and adjustable glass shelves, soffits with fluorescent lights are used; the material is Eastern combgreen oak, sanded and finished with lacquer and Formica for service plates and the wrapping counter. A semi-private corner space has been arranged in the back of the store for display of high-class merchandise and factual sale.

Special care has been taken regarding lighting and fixtures; there is a combination of luminous direct and indirect lighting. The main fixture is suspended beneath the ceiling of the mezzanine and two rows of specially designed fixtures add to the apparent length of the store. A large mirror in back of the store improves likewise this impression. Superimposed upon general illumination is the spotlighting for display windows and the interior of the store to emphasize color and special features.

**PERFORMANCE STANDARDS**

(From Page 18)

ed highly popular for Interior wall covering and for miscellaneous uses where only one paintable surface is desired, is being replaced by the new Plypanel Sound 1 Side (S01S) grade. The face of the Sound 1 Side panel is, and has been, the same as that of the old Plywood. In the back of the panel being retained, blemishes and appearance defects permitted must be smaller than those previously allowed in the old Plywood back, but may be somewhat more conspicuous than in the back of the Plypanel S01S grade under the previous standard.

Also eliminated from the stock grades of fir plywood being manufactured is the Marine grade of the Exterior type. The Marine grade, developed for military during the war, was intended to withstand the extreme use conditions imposed by the Army and Navy; very little has been produced since the war's end. Some manufacturers will continue to produce, on special order, Exterior plywood of selected veneer and special ply construction in accordance with specifications of the individual producer.

All grades of Exterior type fir plywood, of course, are manufactured with the same waterproof phenolic resin adhesives. The Sound 2 Sides grade of Exterior plywood has proved most popular for most uses either in commercial or pleasure craft; for some applications, Sound 1 Side panels are specified.

A CPA permit has been granted for the construction of a \$1,000,000 Plant Science Building at the University of California at Berkeley.

## BOOK REVIEWS

### PAMPHLETS AND CATALOGUES

**STAINLESS STEEL VALVES & FITTINGS.** Catalog No. 47 Alloy Steel Products Company, Inc., Linden, N. J.

A completely illustrated and charted 60-page brochure devoted to valves and fittings used in the manufacture and processing of chemicals, dye-stuffs, food and beverages, oil refinery products, pharmaceuticals, plastics, pulp and paper, soap and fatty acids, textiles and numerous other processes.

**RADIANT PANEL HEATING—A Non-Technical Discussion.** Revere Copper and Brass Inc., 230 Park Avenue, New York 17, N. Y.

A simple readable 38-page, 2-color, non-technical booklet on Radiant Panel Heating, describing advantages; disadvantages relative advantages of ceiling panels, wall panels, and floor panels; and best methods of distributing the panel surface. Copies from publisher.

**HOW ARCHITECTURAL PORCELAIN ENAMEL PRODUCES PROFITS.** Porcelain Enamel Institute, Inc., Washington 5, D. C.

Architectural porcelain enamel is described in a new 16-page brochure, including its uses in standardized new constructions and remodeling. Its advantages to building owner, architect, and contractor is well illustrated and described. Copies of the booklet A.I.A. File No. 15-H-2 are available without cost from the Institute.

**REMPE ENGINEERING DATA BOOK.** Rempe Co., 340 N. Sacramento Blvd., Chicago 12. By Arthur G. Vogel, A.S.R.E., W. S. E. Price \$1.50.

Provides all the fundamentals of pipe and fin coil calculation as compiled by engineers especially for draftsmen and designers to use in laying out pipe and fin coils for heating and cooling application.

Also treats subject of inspection, testing and finishing of coils, calculation of heating and cooling coils, methods of computing fin coil surfaces, application of coils to particular types of heating and cooling units, and properties of saturated steam. Illustrated.

**ELECTRIC PLANTS.** D. W. Onan & Sons, Inc., Minneapolis, Minn.

A new, attractive, three-color catalog covering a complete line of electric plants (Form A-138).

Fully illustrated, electric generating plants in sizes ranging from 350 to 35,000 watts A.C. in all standard voltages, frequencies and phases are described. Battery charging plants are also described. Full details from publisher.

## PACIFIC MANUFACTURING CO.

HIGH CLASS INTERIOR FINISH  
QUALITY MILLWORK

142 SANSOME ST., SAN FRANCISCO  
GARfield 1-7755

6820 MCKINLEY AVE., LOS ANGELES  
THornwall 4196

BUILDERS EXCHANGE, OAKLAND

## "AMERICAN - MARSH"

CONDENSATION UNIT

Pumping  
Machinery  
for  
Every  
Purpose

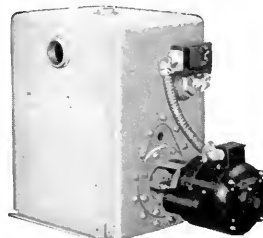

For Service

Call

DOuglas

2-6794

or

MUtual 8322

**SIMONDS MACHINERY CO.**

SAN FRANCISCO  
816 FOLSOM

LOS ANGELES  
455 EAST 4TH

## VERMONT MARBLE COMPANY

Producers and Finishers  
of  
Domestic and Imported Marbles

525 MARKET STREET, SAN FRANCISCO  
Phone SUtter 1-6747  
3522 COUNCIL STREET  
(Beverly Blvd. at Virgil Ave.)  
LOS ANGELES 4, CALIF.  
Telephone Fairfax 7834



The Most Complete Line of  
STEELS and BUILDING MATERIALS  
Made by a Single Producer



See Sweet's Catalog File or write us for  
full information.

**REPUBLIC STEEL CORPORATION**

GENERAL OFFICES: CLEVELAND, OHIO

DENVER, COLORADO . . . . . CONTINENTAL OIL BUILDING  
LOS ANGELES, CALIFORNIA . . . . . EDISON BUILDING  
SALT LAKE CITY, UTAH . . . . . WALKER BANK BUILDING  
SAN FRANCISCO, CALIFORNIA . . . . . RIALTO BUILDING  
SEATTLE, WASH. . . . . WHITE-HENRY-STUART BUILDING

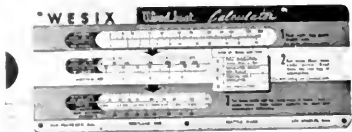

**WESIX** *Wiredheat* **CALCULATOR**  
 "Slide-rule" style, for quick computing of the correct WESIX Wiredheat SYSTEM for any house. Available to architects, engineers, contractors and dealers.

Also available NOW our

**NEW CATALOG**

Mailed free on request



**WESIX ELECTRIC HEATER CO.**

390 First Street, San Francisco

Telephone: GARfield 1-2211

**IN THE NEWS**

**CABINET CATCH**

Latest addition to the cabinet hardware line of THE STANLEY WORKS, New Britain, Conn., is the New No. 32 Catch.

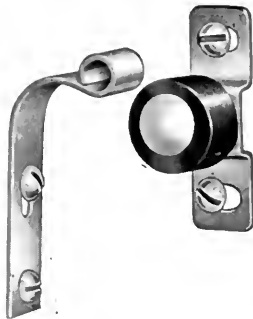

Smartly designed for either lipped or flush doors; no mortising necessary; easy to adjust. Is quiet in operation.

**ASSOCIATED GENERAL CONTRACTORS**

Adolph Teichert, Jr., President of A. Teichert & Son, Inc., Sacramento, California has been nominated to the vice presidency of the Associated General Contractors of America.

He succeeds Dwight W. Winkelman of New York who will be elevated to the presidency of the organization for 1948.

The annual meeting of the association will be held in Dallas, Texas, February 9-12, 1948.

**THE YOUNGER CONSTRUCTION CO.**, San Francisco, have been awarded contract for construction of a warehouse building for the Purity Stores in Gilroy, California.

**DALEY BRO'S CONTRACTORS**, Belmont, California, have been awarded contract for moving and erecting a gymnasium building for the Stockton Junior College.

**ARTHUR BRO'S CONTRACTORS**, San Mateo, have been awarded general contract for construction of a 60 bed wing addition to the San Mateo County Relief Home. Estimated cost \$519,000.

**PACIFIC TEL & TEL CO.** will build a new exchange building at Quincy, California.

**TOURNALAYER**  
 The Sales Division of the R. G. LeTourneau, Inc., have opened a new division office in Los Angeles, California.

**ENGINEER APPOINTED**  
 Joseph F. Manildi, Ph.D., has been appointed assistant professor of engineering on the Los Angeles campus of the University of California, and will also serve on the Extension staff.

He was formerly Director of Research and Chief Engineer for the G. M. Giannini & Co., Inc., directing a research program in jet propulsion engines.

**MORE WINDOW VALUE FOR YOUR MONEY!**

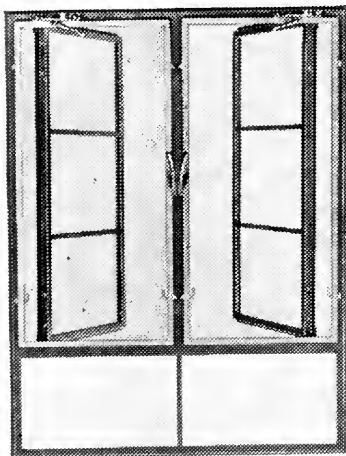

*with*  
**CECO**  
**Steel Windows**

- Easy opening and closing . . . no sticking or warping.
- "Bonderized" as a protection against rust.
- Ceco steel windows provide for economical wall construction . . . enhance the architectural effect of the building.
- Weathertight . . . durable and fire resistive.
- The Ceco window line is so complete and so flexible that every type of building from the small residence to the largest institutional structure may be equipped with tight weather seal Ceco steel windows.

CONTACT THE NEAREST P.C.A. OFFICE

**PCA Pacific Coast Aggregates, Inc.**

SAN FRANCISCO  
 400 Alabama St.  
 KLondike 2-1616

OAKLAND  
 2400 Peralta St.  
 GLencourt 1-0177

SACRAMENTO  
 16th and A Sts.  
 Ph. 3-6586

STOCKTON  
 1020 E. Main St.  
 Phone 8-8643

SAN JOSE  
 790 Stockton Ave.  
 Ballard 8670

FRESNO  
 2150 G St. or 414 P St.  
 Ph. 3-5168 Ph. 4-3065

**Bronskin**  
**VAPORSEAL**

The resilient building paper creped to S-T-R-E-T-C-H

Quality Products Since 1895

**ANGIER PACIFIC CORPORATION**  
 55 NEW MONTGOMERY ST. 7424 SUNSET BOULEVARD  
 SAN FRANCISCO 5, CALIF. LOS ANGELES 44, CALIF.

A complete line of Angier products available from your building material dealer.

**NEW FENESTRA STEEL  
 BEDROOM WINDOW**

An in-tilting vent at the sill that protects against drafts, rain or falls is the feature of a new FENESTRA steel bedroom window by the DETROIT STEEL PRODUCTS COMPANY.

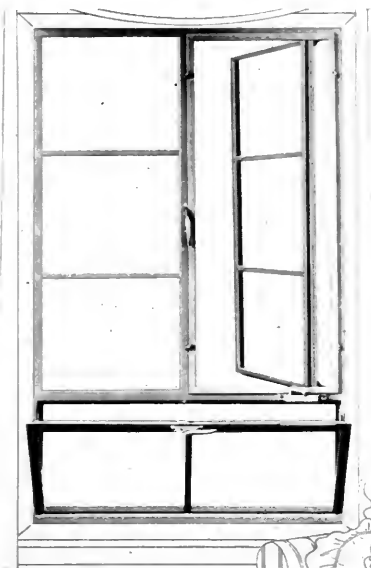

When opened, air currents go upward toward the ceiling, and rain is deflected outward. Made of steel; finger tip control; Cam action lock; can be fitted with all-metal screens.

**GERM KILLING LIGHT**

A new all purpose germicidal unit designed for either direct irradiation with sterilizing ultraviolet, or indirect room air disinfection called PROTECT-O-RAY (No. G211) has been announced by Lustra Corporation of America, New York.



Can be hung anywhere for temporary or permanent installation; chromium plated with satin aluminum reflecting surface; completely wired and equipped with 15-watt germicidal ultraviolet tube, 10-foot cord, and all necessary equipment.

Phone GARfield 1-1164

**Thomas B. Hunter**

DESIGNER OF HEATING

AIR CONDITIONING  
 VENTILATING AND WIRING  
 SYSTEMS, MECHANICAL  
 AND ELECTRICAL EQUIP-  
 MENT OF BUILDINGS



41 SUTTER STREET  
 ROOM 710

San Francisco

California

**THE TORMEY  
 COMPANY**

**GENERAL PAINTERS  
 AND DECORATORS**

Phone UNderhill 1-1913

563 FULTON STREET  
 San Francisco

**MULLEN MFG.  
 COMPANY**

BANK, STORE AND OFFICE  
 FIXTURES—CABINET WORK  
 OF GUARANTEED QUALITY  
 CHURCH SEATING

Office and Factory  
 60-80 RAUSCH ST., Bet. 7th and 8th Sts.  
 San Francisco  
 Telephone UNderhill 1-5815

**Scott Company**

HEATING . . PLUMBING . . TILE



243 MINNA STREET  
 SAN FRANCISCO

Phone EXbrook 2-6741

**DINWIDDIE  
 CONSTRUCTION  
 COMPANY**

**BUILDERS**

CROCKER BUILDING  
 SAN FRANCISCO

*Fine*  
**ENGRAVINGS**

**POOR  
 RICHARD**  
 PHOTO ENGRAVING CO.  
 320-324 COMMERCIAL STREET  
 SAN FRANCISCO, 13



**HERRICK  
 IRON WORKS**

STRUCTURAL STEEL  
 REINFORCING STEEL

18TH AND CAMPBELL STS.  
 OAKLAND, CALIF.  
 Phone GLencourt 1-1767

## INDEPENDENT IRON WORKS

Steel Buildings  
Service Stations  
Steel Storage Tanks  
Fabricated Plate Work  
Steel & Sheet Metal Products  
Fabricated Structural Steel  
Steel Distributors

Eighth & Pine Sts. Oakland, 7

## George F. Brayer

ELECTRICAL  
CONTRACTOR

166 Seventh Street  
San Francisco

Phone: Market 1-1761

## PITTSBURGH TESTING LABORATORY

Successors to  
SMITH, EMERY & COMPANY

*Testing and Inspecting  
Engineers and Chemists*

Structural Materials, Structures  
Equipment, Pipe, Soils.

651 Howard St., San Francisco 5  
EXbrook 2-1747

## A. F. MATTOCK CO.

*Builders*



212 CLARA STREET  
SAN FRANCISCO

## Index to Advertisers

ALADDIN Heating Corp.	48
ANGIER Pacific Corp.	47
ARCHITECTS Reports	40
BASALT Rock Company	Back Cover
BAXTER & Company, J. H.	36
BRAYER, Geo. F.	43
BRUNER Marble & Tile Co.	27
CLASSIFIED Advertising	43
CLINTON Construction Company	44
DETROIT Steel Products Co.	7
DINWIDDIE Construction Co.	47
DUNN Louis C. Co.	27
FORDERER Cornice Works	40
FOX Tile Co.	39
FREEMAN, Jack	26
FULLER, W. P. Co.	8
GUNN Carle & Company	43
HANKS Inc., Abbott A.	48
HAWS Drinking Faucet Company	5
HERRICK Iron Works	47
HOGAN Lumber Company	44
HUNT Robert W., Company	48
HUNTER, Thos. B.	47
INDEPENDENT Iron Works	48
JUDSON Pacific-Murphy Corp.	40
KRAFTILE Company	34
MATTOCK, A. F.	48
METROPOLITAN Blind Co.	27
MICHEL & Pfeiffer Iron Works	48
Inside Back Cover	
MULLEN Mfg. Co.	47
MUELLER Brass Co.	2
NORTHERN California Electrical Bureau	35
OLESEN, Otto K. Co.	26
PACIFIC Coast Aggregates, Inc.	46
PACIFIC Coast Gas Association	46
Inside Front Cover	
PACIFIC Manufacturing Company	45
PACIFIC Portland Cement Company	*
PACIFIC Telephone & Telegraph Co.	33
PACIFIC Tile & Porcelain Co.	39
PETERSON, Harold E.	30
PITTSBURGH Testing Laboratory	48
POOR RICHARD Engraving	47
REMILLARD-Dandini Co.	48
REPUBLIC Steel Corporation	45
SANTA Maria Inn	44
SCOTT Co.	47
SHUGART, Harold E. Co., Inc.	30
SIMONDS Machinery Company	45
SIMPSON Logging Co.	6
SISALKRAFT Company	44
SMOOT-Holman Co.	37
STANLEY Works, The	*
SUNBEAM Lighting Co.	28
SUPER Concrete Emulsions, Ltd.	27
TAYLOR Co., Halsey W.	39
TORMEY Company, The	47
U. S. BONDS	1
VERMONT Marble Company	45
WESTERN Asbestos Company	*
WESIX Company	46
WOOD, E. K., Lumber Company	36

\*Indicates Alternate Months

## REMILLARD-DANDINI Co.

Brick and  
Masonry Products



400 MONTGOMERY STREET  
SAN FRANCISCO, CALIF.

## A L A D D I N Heating Corp.

Specializing in  
QUALITY HEATING  
EQUIPMENT

2222 San Pablo Avenue  
OAKLAND  
TWinoaks 3-1022

## ABBOT A. HANKS, INC. Engineers & Chemists

INSPECTING — TESTING — CONSULTING  
CONCRETE • STEEL • MATERIALS  
CHEMICAL AND TESTING  
LABORATORIES

• RESEARCH AND INVESTIGATION •

TESTS OF STRUCTURAL MATERIALS  
DESIGN OF CONCRETE MIXES  
SHOP AND ERECTION INSPECTION OF  
STRUCTURES AND EQUIPMENT  
INVESTIGATION OF STRUCTURES  
AND MATERIALS  
TESTS AND INVESTIGATION OF  
FOUNDATION SOILS  
FIRE RESISTANCE AND INSULATION  
TESTS

624 Sacramento Street, San Francisco

## Robert W. Hunt Company ENGINEERS

Inspection • Tests • Consultation  
Schools and Other Structures  
Are Built as Designed

*When Construction Materials are  
Inspected at point of Manufacture  
and during Erection by*

ROBERT W. HUNT COMPANY  
*Cement, Concrete, Chemical, Metallurgical,  
X-Ray and Physical Laboratories*

Chicago - New York - Pittsburgh  
Los Angeles - All Large Cities  
San Francisco, 251 Kearny Street

# ARCHITECT AND ENGINEER

SEVENTH WOODLANDS . . . Merla County, California



MERVY PARKER CLARK ARCHT.

NOVEMBER

1947

# DEPENDABLE



A  
"PACIFIC  
PRODUCT"

*Produced by*

**PACIFIC PORTLAND  
CEMENT COMPANY**

San Francisco • Los Angeles  
Portland

*Sold by*

**YOUR BUILDING  
MATERIALS DEALER**

# UNIFORM - TIME TESTED



# ARCHITECT

Vol. 171 No. 2

# AND ENGINEER

ARCHITECTS' REPORTS—Published Daily  
Telephone DOuglas 2-8311

## Contents for

# NOVEMBER

E. H. WILDER  
Editor

MARK DANIELS, A.I.A.  
Associate Editor

PROF. LELAND VAUGHAN  
Landscape Architecture

MICHAEL GOODMAN  
Planning

JOHN S. BOLLES, A.I.A.  
Book Reviews



### COVER PICTURE:

KENT WOODLANDS, Marin County  
California

Designed by Hery Parke Clark of Clark & Beuttler, Architects, San Francisco, for Mr. Roger Kent, of the famous California pioneer Kent family, "The Kent House" is of redwood plywood stained a driftwood color (both inside and out) and combines gracious spaciousness with individual living privacy; plus a close integration of garden and house.

*Esther Born, Photo*

EDITORIAL NOTES . . . . .	4
NEWS & COMMENT ON ART . . . . .	8
A PLANNED COMMERCIAL CENTER, Hillside Dormitories, Vallejo, California By CECELIA MOGENSEN, A.I.A.	10
THE ARCHITECT AND THE COLOR CONSULTANT—Elizabeth Banning By EUGENE BURNS	12
ROCKY BUTTE JAIL, Portland, Oregon . . . . . By A. J. DREYER, Architect	18
ISOGONIC DRAFTING, a New Tool for the Architect . . . . . By SIBLEY S. MORRILL, Willard Engineering Co.	22
RESEARCH LABORATORY COMPLETED FOR PABCO, Emeryville, California . . . . .	25
ADDRESS BY JAMES W. FOLLIN, Assistant Administrator, Federal Works Agency . . . . .	27
A.I.A. ACTIVITIES . . . . .	31
WITH THE ENGINEERS . . . . .	32
IN THE NEWS . . . . .	37, 46, 47
LANDSCAPE ARCHITECTURE, Notes of the Profession . . . . .	38
ESTIMATOR'S GUIDE, Building and Construction Materials . . . . .	41
BUILDING TRADES WAGE SCALES, Northern and Central California . . . . .	43
CLASSIFIED ADVERTISING . . . . .	43
BOOK REVIEWS, Pamphlets and Catalogues . . . . .	45
INDEX TO ADVERTISERS . . . . .	48

ARCHITECT AND ENGINEER (Established 1905) is published on the 15th of the month by The Architect and Engineer, Inc., 68 Post St., San Francisco 4; Telephone EXbrook 2-7182. President, K. P. Kierulff; Vice-President and Manager, L. B. Penhorwood; Treasurer, E. N. Kierulff.

Los Angeles Office: Wentworth F. Green, 6605 Hollywood Blvd., Los Angeles 28, Telephone HEMPstead 3171.

Entered as second class matter, November 2, 1905, at the Post Office in San Francisco, California, under the Act of March 3, 1879. Subscriptions United States and Pan America, \$3.00 a year; \$5.00 two years; foreign countries \$5.00 a year; single copy 50c. ARCHITECTS' REPORTS are published daily from this office, Vernon S. Yallop, Manager.



## RACIAL COVENANTS ON REAL ESTATE

The United States Supreme Court has indicated its intent to rule on the validity of racial covenants on real estate and has set a hearing for December 8th on two Washington, D. C. cases. Consideration may also be given to other cases pending before the Court and representing the cities of St. Louis, Detroit, Columbus, and Los Angeles.

The records show that such covenants have been tested and upheld many times by local and state courts, yet despite considerable agitation and pressure the high Court has avoided passing on the issue.

An increasing demand from racial groups for a Supreme Court decision on whether real estate deed provisos are actually constitutional has resulted in the Court's announcement of the pending hearing and ruling.

Billions of dollars worth of real estate property in practically every city in the nation are involved, as is local custom and the habits of a great many people.

\* \* \*

KAY KAYSER, Band Leader and Radio Entertainer, declared at the recent 20th Annual Architects Convention at Catalina Island, that "The Architect is the KEY man in any Hospital Program." The Architect can reduce the cost of hospital and medical care by giving proper consideration to, and knowing the details of, Hospital facilities and personnel and costs of operation.

\* \* \*

## WE MUST NEVER LET IT HAPPEN HERE

A recent communication from Frank W. Cortright, Executive Vice-President of the National Association of Home Builders of the United States addressed to the members of his organization is a simple, straight from the shoulder report on home building conditions throughout Europe.

Says Mr. Courtwright—"I have just returned from a three weeks' look at the wreckage of the home building industry in other countries. I visited six countries (His trip included England, France, Belgium, Holland, Denmark and Sweden), and while the story differed somewhat in each place, the totally inadequate volume of construction was general and resulted from various rigid governmental controls and subsidization which, over a period of years, has taken its full toll of the industry."

Emphasis is placed on the fact that few Ameri-

cans are aware of the tremendous toll taken by the recent War on the populations of countries over which the fighting armies passed. Destruction was not limited to personnel and equipment engaged in actual combat, but included the civilian population and their possessions resulting in thousands of persons becoming homeless.

Government regulations imposed during World War I in some of the countries were never recinded. This resulted in inadequate home facilities even prior to the World War II.

If we can learn from those who have an opportunity to see first hand the plight of European countries, it is obvious we must never permit wartime government controls to be extended into peacetime economy.

\* \* \*

## NOT A SERIOUS PROFESSIONAL PROBLEM

A great deal of attention has been centered recently throughout the nation upon European professionals who, uprooted from their normal life by the late War, are now seeking to establish themselves in new environments, new homes, new professional endeavor, and a country new to them.

Every profession, and the practice of Architecture is no exception, has experienced the effect of individuals endeavoring to inject the theory and sometimes practice of prewar European professional procedure.

In but a very few instances, these displaced people have been unable to grasp immediately the American way of life, and rather than to successfully adjusting themselves to their new surroundings, have assumed that America and Americans should accept and prefer their old world thinking.

It should be remembered that this nation has been developed to its present position as one of the greatest nations of the World—largely by people from many lands who were discontented and dissatisfied with conditions existant in their old world surroundings, and sought a new and greater opportunity.

In the long run these new-comers will recognize that here in America the members of the profession to which they are allied, have already adopted the progressive thinking, the high professional standards, and the better ways of life which were in reality merely wishful thinking in prewar Europe.

Patience, tolerance, and extending a helping hand is one way to convert a profession into a successful enterprise for all concerned.

# Many Models to choose from

...the complete  
line of  
**HAWS...**

- Wall Hung Drinking Fountains
- Multiple Bubbler Wall Hung Fountains
- Pedestal Fountains
- Multiple Bubbler Pedestal Fountains
- Electric Water Coolers
- Ice Water Coolers and Fountains
- Small Receptacle Drinking Fountains

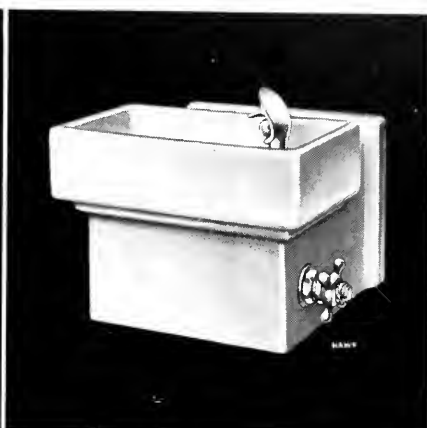

Always specify

# HAWS

—the finest in  
drinking water facilities

**HAWS DRINKING FAUCET CO.**

SINCE 1909

1808 HARMON STREET • BERKELEY 3, CALIFORNIA

Agents and Sales Representatives  
in all Principal Cities

where people must be served with cool, refreshing drinking water... HAWS Drinking Fountains, Faucets and Electric Water Coolers are the logical choice. They are sanitary, operate efficiently and dependably, are economical and meet all architectural requirements for beauty and design. You are providing for complete drinking water satisfaction when you specify HAWS. Write for complete details.



# INSULATING BUILDING BOARD

*... made better in the West and distributed through Western Lumber Dealers*

More and more Simpson Insulating Building Board is being shipped daily from our new plant to western lumber dealers. That means that every bit of our new Insulating Building Board is being sent to western dealers, for that is the Simpson sales policy. We believe not only in producing a superior product but likewise in maintaining high standards in our dealer relationship. Dealers, architects and builders alike have expressed splendid enthusiasm for the new Simpson Insulating Board... for its structural strength, uniformity, new tapestry-like finish and its paint color. The map below shows locations of our distributors. If you require use of our technical field service, please feel free to request it through the nearest Simpson distributor.

**WOODFIBER DIVISION  
SIMPSON LOGGING CO.**  
Plant at Shelton, Washington  
Sales Division, SIMPSON INDUSTRIES  
1010 White Building  
Seattle 1, Washington

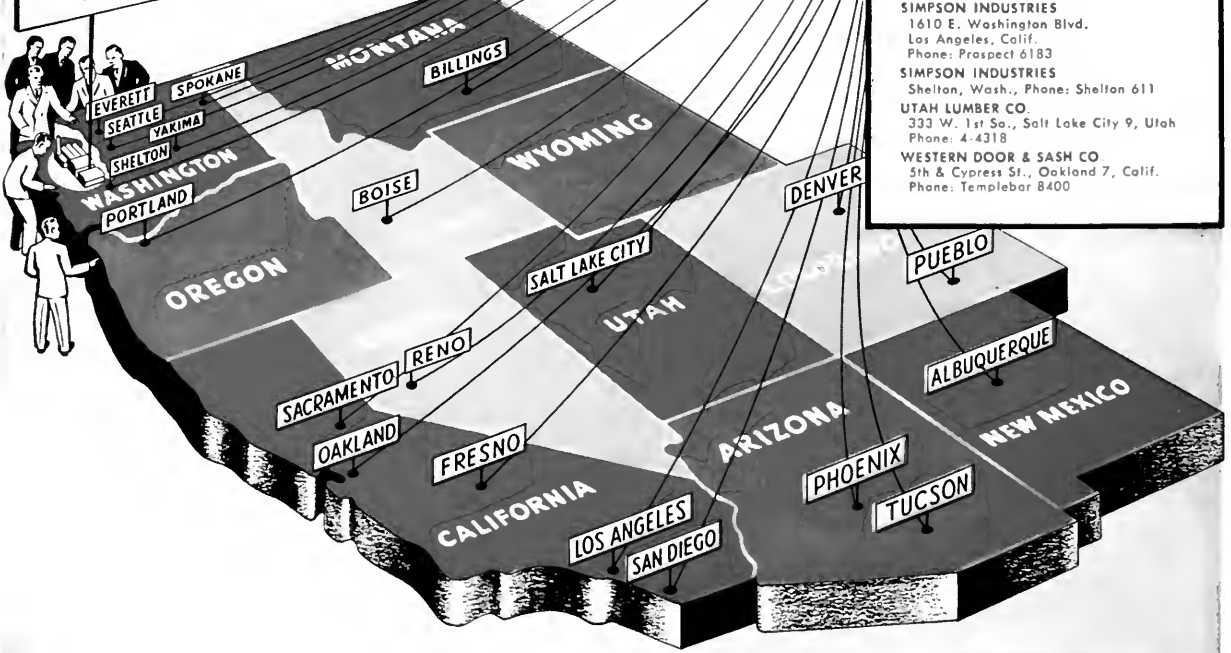

## Dealers!

SEE YOUR NEAREST  
DISTRIBUTOR LISTED HERE

- ARIZONA SASH, DOOR & GLASS CO.  
521 S. 9th Ave., Phoenix, Ariz.  
Phone: 3-3151
- ARIZONA SASH, DOOR & GLASS CO.  
657 W. St. Mary's Road, Tucson, Ariz.  
Phone: 1699
- CALIFORNIA BUILDERS SUPPLY CO.  
700 Sixth Avenue, Oakland 4, Calif.  
Phone: Highgate 6015
- CALIFORNIA BUILDERS SUPPLY CO.  
19th & S Sts., Sacramento 14, Calif.  
Phone: 2-0788
- CALIFORNIA BUILDERS SUPPLY CO.  
3180 Hamilton Ave., Fresno, Calif.  
Phone: 2-9470
- CALIFORNIA PANEL & VENEER CO.  
955-967 So. Alameda St.,  
Los Angeles, Calif., Phone: Trinity 0057
- CONTINENTAL LUMBER CO.  
P.O. Box 2042, Boise, Ida., Phone: 450
- ELLIOTT BAY LUMBER CO.  
600 W. Spokane St., Seattle, Wash.  
Phone: Elliott 8080
- ELLIOTT BAY LUMBER CO.  
2712 McDougall St., Everett, Wash.  
Phone: Main 150
- ELLIOTT BAY LUMBER CO.  
Box 188—Union Gap Station  
Yakima, Wash., Phone: 24671
- EXCHANGE LUMBER &  
MANUFACTURING CO.  
P.O. Box 1514, Spokane 7, Wash.  
Phone: Glenwood 1621
- FROST HARDWOOD LUMBER CO.  
Market of State St., San Diego, Calif.  
Phone: F-7224
- LUMBER DEALERS, INC.  
T A Box 5222, Denver 17, Colo.  
Phone: Tabor 6141
- LUMBER DEALERS, INC.  
108 South Main St., Pueblo, Colo.  
Phone: 4881
- LUMBER DEALERS, INC.  
423 N. 33rd, Billings, Mont., Phone: 3911
- MORRISON-MERRILL & CO.  
353 No. Park Street, Reno, Nevada  
Phone: 2-2196
- NEW MEXICO COMPANY  
1401-15 North 12th St.,  
Albuquerque, New Mexico  
Phone: 3-1708
- CHAS. E. SAND PLYWOOD CO.  
1106 N.W. 16th Ave., Portland, Ore.  
Phone: Atwater 6421
- SIMPSON INDUSTRIES  
1610 E. Washington Blvd.  
Los Angeles, Calif.  
Phone: Prospect 6183
- SIMPSON INDUSTRIES  
Shelton, Wash., Phone: Shelton 611
- UTAH LUMBER CO.  
333 W. 1st So., Salt Lake City 9, Utah  
Phone: 4-4318
- WESTERN DOOR & SASH CO.  
5th & Cypress St., Oakland 7, Calif.  
Phone: Templebar 8400

*Designed for beauty... standardized for economy*  
**NEW FENCRAFT FAMILY\* OF WINDOWS**

\*Casement... Projected...  
**Combination**

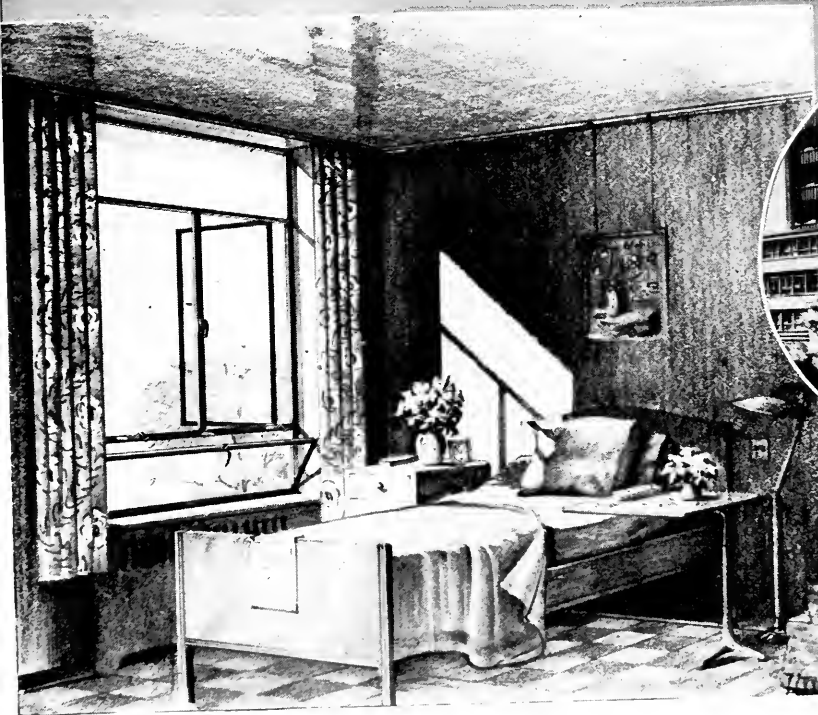

*Suggestion:*

For hospital bedrooms, Fenecraft Standard Intermediate Combination Windows, such as type 626 illustrated, provide abundant sunlight, and controlled fresh-air ventilation. Sill vent serves as built-in wind guard.

Three new lines of Fenecraft Windows now offer new high quality, lower cost and important installation economy.

Built of specially-designed steel casement sections, by craftsmen in the shops of America's oldest and largest steel window manufacturer, all Fenecraft Windows beautify both the outside and the inside. They provide permanently easy operation, firesafety, more daylight, better ventilation, safe cleaning, superior screening, lasting weather-tightness and low maintenance cost.

Singular economy in first cost is made possible by standardized manufacture—the concentration of production on standard types and sizes.

Uniform installation details, plus the coordination of window dimensions with those of collateral materials in the wall, minimize installation cost.

Eminently suited for America's finest hospitals, Fenecraft Windows are now being shipped to many localities. For product details, mail the coupon below.

*Fenestra*

**FENCRAFT INTERMEDIATE STEEL WINDOWS**

Detroit Steel Products Company  
 Dept. AE-11, 2262  
 2250 East Grand Blvd.,  
 Detroit 11, Michigan

Please send me data on types and sizes of the new Fenecraft family of Fenestra Windows:

Name \_\_\_\_\_

Company \_\_\_\_\_

Address \_\_\_\_\_

# NEWS AND COMMENT ON ART



TITLE "W-2" 1935

by LUCIEN LABAUDT

Bought by the San Francisco Art Commission from the 57th Annual Exhibition and now in custody of the San Francisco Museum of Art.

## SAN FRANCISCO MUSEUM OF ART

The schedule of exhibitions and events announced for the month of November will include:

EXHIBITIONS: Christmas Sale, through December 14; William L. Gerstle Collection, November 16; Art as Therapy for Veterans, Sponsored by the American Women's Volunteer Services, through December 16; Twenty-second Annual Exhibition of the San Francisco Women Artists, Through December 15; Thirty-third Annual Exhibition of The California Society of Etchers, through December 14; The First National Print Annual of the Brooklyn Museum, through December 6.

\* \* \*

A MEASURE OF PICASSO. The Women's Board will present three lectures by Richard Borden Freeman, Thursday afternoon, 2:30 p.m., November 13, 20, and December 4. The subjects will cover "Depth", "Breadth", and "Height."

\* \* \*

BERKELEY CHAMBER SINGERS. Under the direction of Iva Dee Hiatt, a program will be presented Friday evening 8:15, November 21. Works of Darius Milhaud, Aaron Copland, Benjamin Britten, Maurice Ravel, Paul Hindemith and others in the contemporary musical scene will be sung.

\* \* \*

CHILDRENS ART CLASSES. Saturday morning 10 to 11:30, conducted by Nora Lee Rohr.

FAMOUS FILM SERIES. Tuesday evenings at 8 o'clock

## CALIFORNIA PALACE OF THE LEGION OF HONOR

Thomas Carr Howe, Jr., Director, has announced the following schedule of exhibitions and special events for November.

EXHIBITIONS will include Photographs by Aaron Siskind; Second Annual Exhibition of Contemporary Painting, opening November 19; Paintings looted from Holland; Paintings in France, 1939-1946; Renaissance Venice; Alma de Bretteville Spreckels collection of Sculpture by Auguste Rodin; the Mildred Anna Williams collection of Paintings, Sculpture, Tapestries and furniture; and the Collis Potter Huntington Memorial collection of 18th Century French Paintings, Sculpture, Tapestries, Furniture and Porcelain.

EDUCATION ACTIVITIES will include a tour of the Museum each Wednesday and Friday afternoon at 2:30. Saturday morning Art Classes for Children, under direction of Katharine L. Parker and Lilly Weil Jaffs. Painting Classes for Adults, each Saturday afternoon.

## M. H. deYOUNG MEMORIAL MUSEUM

The schedule of Exhibitions and activities for the month of November, as announced by Walter Heil, director, will include:

EXHIBITIONS: Paintings and Drawings by Channing Peake; Paintings by Dan Lutz; Paintings by William Schwartz; Chinese Paintings by Tseng Yu-Ho; Sculpture and Drawings by Chana Orloff; "The Young in Art" an exhibit of Drawings and Paintings by Children in the Museum's classes;

and Watercolors, by students of architecture, University of California.

ACTIVITIES: Painting for Pleasure, Saturday and Friday afternoons. Saturday classes for Children, conducted by Miriam Lindstrom.

---

#### MILLS COLLEGE ART GALLERY

An exhibition of Arts and Crafts by the Oakland Public School Teachers, sponsored by the Art Section, will be shown from November 2nd to December 8th. Exhibition will be open on Wednesday, Friday, and Sunday, 3 to 5 p.m.

Ray Faulkner, Chairman of the Art Department, Stanford University will give a lecture November 19, 8 p.m., on the subject "The Contribution of Art to Education."

---

#### UNIVERSITY OF OREGON SCHOOL OF ARCHITECTURE

The School of Architecture and Allied Arts at the University of Oregon, through its chairman of Exhibitions Mark R. Sponenburgh, has announced the following exhibit for November.

A comprehensive display of TEXTILES featuring Scalandre. It will be shown November 22 to December 4.

---

#### CITY OF PARIS ART IN ACTION

The "Pictures of the Month" for November will feature "The Plaza" and "Taxco Afternoon" by Caroline Martin. New Horizons in Lithography will be shown by Robert Cole Caples.

The Rotunda Gallery, on the fourth floor, will feature an exhibit of oils and watercolors by Paul Carey, Douglas Parshall, Louis Siegriest, and an exhibit of wood forms by Cornelia Chase.

The showing will continue until November 29th.

---

#### DOROTHY W. LIEBES HONORED

The American Institute of Architects' "Craftsmanship Medal" was recently awarded to Miss Dorothy W. Liebes of San Francisco by Earl T. Heitschmidt, A. I. A., Regional Director of the Sierra Nevada District.

Miss Liebes was chosen to receive this high award at the 79th Annual Convention of the A. I. A., held at Grand Rapids, Michigan, this year.

---

SCHOOL CONTRACT AWARDED to N. H. Sjoberg & Son of Oakland for the construction of Grammar School addition at Pleasanton, California. John J. Donovan & Ralph Kerr, Berkeley, are the Architects.

#### HELICOPTER FACTORY BUILDING

The Remmet Construction Company of Palo Alto have been awarded a \$250,000 contract for the construction of a helicopter building at the East Palo Alto airport.

The building will be 160' x 200' structural steel frame, Haydite block and protected metal, concrete floors and asphalt tile, according to United Helicopters, Inc. owners of the building.

---

NEWSPAPER BUILDING at Salinas, California, to house the Salinas Daily Californian will cost \$332,677, according to Eugene T. Denham, Columbus, Ohio, Architect. Harold C. Geyer, Monterey, is the contractor.

---

#### NAVAL TEST STATION HOUSING

A contract has been awarded Haddock Engineers, Ltd., of Montebello, California, for the construction of housing at the Naval Test Station at Inyokern, California.

According to the U. S. Bureau of Yards and Docks, owners of the project, costs of the housing will approximate \$3,187,259.

---

WILLIAM HOWARD EDIE, A.I.A., Architect, has become associated with the firm of BAMBERGER & REID, San Francisco, California.

---

#### TRANSMITTING STATION

Stolte, Inc., of Oakland, California, have been awarded a cost-plus and fixed fee contract for the construction of a U. S. Navy radio transmitting station near Dixon, California. It is estimated the cost of the project will exceed \$1,000,000.

---

#### SIXTH PAN AMERICAN CONGRESS OF ARCHITECTS

Five projects designed by the firm of Franklin, Kump & Falk, architectural engineers of San Francisco, were included in the U. S. Department of State's exhibit at the VI Pan American Congress of Architects held in Peru, during October.

The projects included the Acalanes Union High School at Lafayette, Sill Building at Bakersfield, United Air Lines Terminal at Merced, United Air Lines Terminal at Modesto, and the City Hall of Fresno.

---

BLANCHARD, MAHER & LOCKHARD, Architects of Reno, Nevada, have announced the construction of a new heating plant for the University of Nevada at Reno to cost \$378,000.



AIR VIEW OF HILLSIDE DORMITORIES Near Vallejo, California

# A PLANNED COMMERCIAL CENTER

Hillside Dormitories, Vallejo, California

By **CECELIA MOGENSEN, A.L.A.**

In the office of **Hahn & Campbell & Associates,**  
Planning Consultants

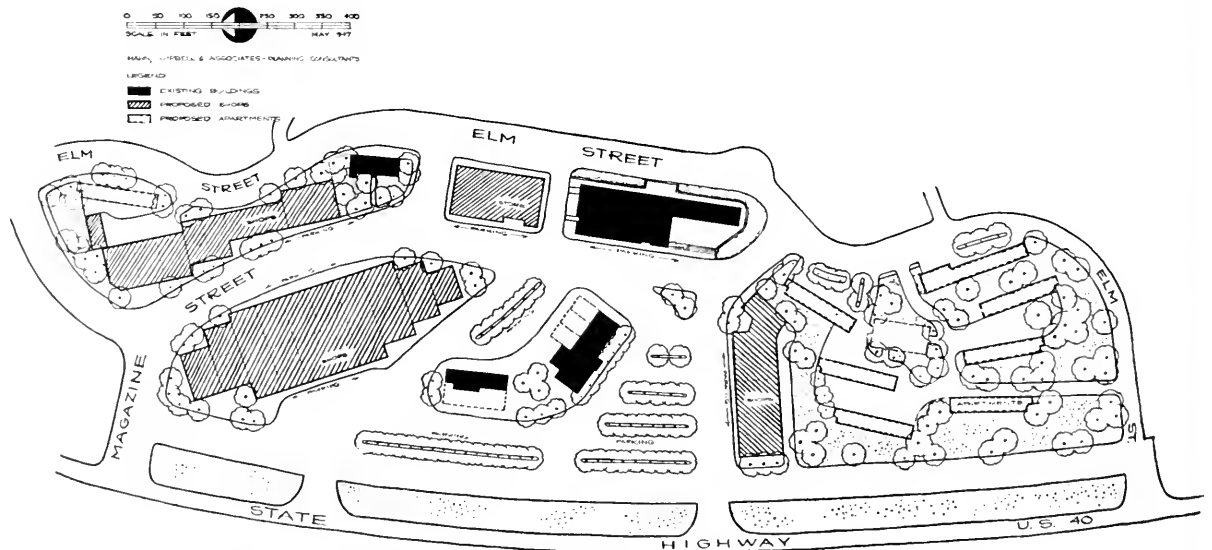

PLAN OF PROPOSED PROJECT AND AREA TO BE INCLUDED



During the late war, thousands of "temporary" housing units were constructed to accommodate the great influx of workers into vital production areas.

Presumably these structures were to be raised at the end of the war emergency, but the changed population structure has now created a new emergency—housing. So the temporary accommodations in most cases are being extended beyond their proper period of time.

Recently, however, the Hillside Dormitories on the Lincoln Highway southwest of Vallejo, California, designed by the Farm Security Administration has been turned back to the original land owner Don Jordan, who now proposes to develop the project to meet current needs for housing in the Vallejo area.

The project is to consist of a commercial center, seven apartment houses, and two thousand homes.

The former buildings, though temporary in character, had been planned and located by a capable group of Designers, Architects, Engineers, and Landscape Architects, working in the Farm Secu-

rity Administration. The planning of this temporary project was done with complete recognition of the terrain and orientation. The buildings were related three dimensional units with ample space between. Thus, the original planning was of such a character and quality as to lend itself efficiently to a housing development. Consequently the foundations of some of those dormitories will be used, and in addition some of the remaining buildings—such as, administration community center, the cafeteria—will be used intact with some remodeling for appropriate use. These latter named can be seen from the aerial photograph on page ??.

The present administration building and cafeteria will be remodeled first. These buildings will be converted into a super-market, including luncheon counter and a children's nursery. The shopping center will accommodate 100,000 people who will come from the immediate residential area, and from the large subdivision of Carquinez Heights, and about thirty per cent will come from through traffic to Vallejo, Fairfield, Suisun, Benicia,

(See Page 45)

**DETAILED SECTION OF PLAN showing location of commercial buildings, apartments, and recreational facilities.**

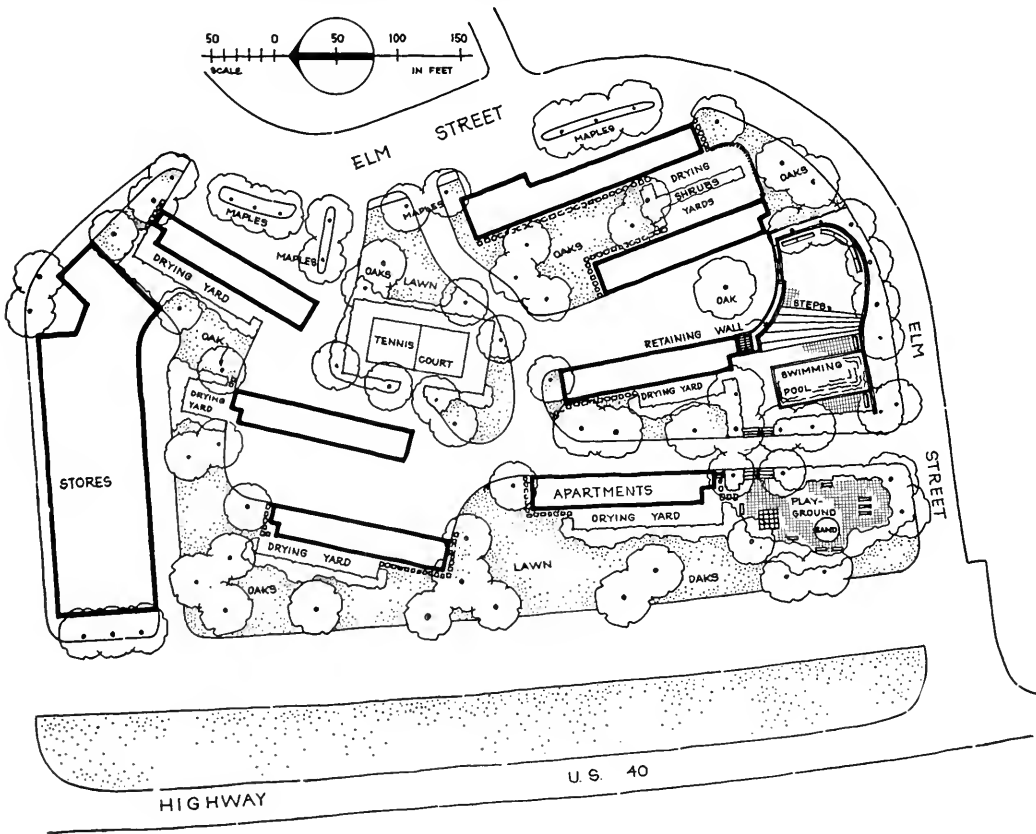



**Robert Keeler  
Moser  
Architect**

**FRED HARVEY RESTAURANT . . . Hollywood, California**

# The ARCHITECT And The COLOR CONSULTANT

By **EUGENE BURNS**

MODERN ARCHITECTURE, with its simplicity of design, demands intelligent color treatment to achieve maximum distinction.

With the professional aid of a color consultant, the architect is assisted in extracting the greatest eye appeal from his design and getting the liveliest effects from his structure while at the same time he saves himself costly hours. Elizabeth Banning, foremost western color consultant—for many years the only one—is authority for the statement.

She recently completed her 1,000th Color Plan, the beautiful Werner Shoe Store, 2020 Broadway, Oakland, for Hertzka & Knowles, Architects, and has had perhaps a greater effect on California's clear modern colors in architecture than any one else.

The western architect's desire for color to enrich his designs, says Elizabeth Banning, is a natural process. The Western slope of the U. S. is in itself a paradise of rich, unescapable colors. The daz-

(See Page 14)

## **ELIZABETH BANNING**

**Color Consultant**

Elizabeth Banning, who has won national acclaim for her distinctive color contribution to industry and business, came to San Francisco in 1936. In the succeeding eleven years she has advanced from minor assignments to being retained as color consultant for the Santa Fe, Fred Harvey, Ford Motor Co., Manning Restaurants, Emporium, Werners, and the W. P. Fuller Co. for whom she has just developed one hundred new deep modern paint colors.





**FRED HARVEY HOLLYWOOD RESTAURANT**

The small existent Fred Harvey Restaurant located on Cahuenga Blvd., a stone's throw from Hollywood Blvd., was established ten years ago as an adjunct to the Santa Fe Trailways Depot. During this time it became less important as a depot restaurant and increasingly popular as a local gathering place due primarily to the famous Fred Harvey cuisine and service. This increase together with heavy wartime traffic necessitated the enlargement and renovations herewith presented.

Rigid restrictions allowed for only a 12 foot wide extension on the bus court giving a long narrow room which was augmented to the existing restaurant by way of three former window openings. In spite of the fact that expenditures did not allow changing the structural shape of the main building, a desired new architectural character

was achieved by the use of totally different materials acting primarily as a screen to the old building. A heavy base and wall masses both inside and out of rose colored Roman brick was interspersed with low plaster panels between shallow bay windows with mitered glass corners. Glass areas are framed with diamond-shaped copper sections oxidized to turn a verte-green color.

Interior materials and furnishings have been designed with extreme simplicity for continued efficient operation, decorative treatment being such that requires little overall maintenance. Floor is a 12" square blue-green tile, ceilings of a softone acoustical tile resembling cork-floated plaster, wood is rift oak, table tops of rift oak, table tops of rift oak formica. Chairs and the predominating circular bancos (Hollywood being rightfully termed a 'banco town') are of natural leather. Wall and ceiling colors are a light turquoise throughout with the exception of the center piers dividing the two dining rooms which are a sand-dune color.

The decorative scheme evolves around the theme of the recent Metro-Goldwyn-Mayer production of "The Harvey Girls" which portrayed historic incidents in the lives of the famous waitresses of the western eighteen nineties. The dining room mural symbolizes a typical western desert town along the reaches of the railway, while the 24 foot long mural in the Cocktail Room characterizes the goings on in the main set on the MGM lot. Paintings done on the set during the filmmaking by Doris Lee are hung strategically. Chinaware repeats the desert motif by use of a stylized cactus on each piece.

Planting by way of different species of desert cactii, Yucca and Joshua Trees, integrally placed both inside and out, is spotlighted at night to give a play of patterns on wall and ceiling surfaces.

*Hoffman-Luckhaus  
Studio, Photos*

**MURALS by  
Edgar Miller**





**MINNESOTA MINING and  
MANUFACTURING CO.**

Los Angeles

**Harry T. Miller, A.I.A.  
Chief Architect**

Approving coloring of the wood finish in the Entrance Foyer as workmen complete the project are: Paul Haugen, Architect; Elizabeth Banning, Color Consultant; and Wm. P. Neil, Engineer.

(From Page 12)

ling strata of the Grand Canyon, the multi-colored layers of the Painted Desert and the Mojave, the sun-splashed beaches of Southern California, the intense blue of Crater Lake and the contrasting whites and greens of Mount Rainier are ever-present examples of color in the architect's own front and back yard.

Like any other artist, the architect contributes aesthetically to his creation through the use of colors.

The elimination of traditional design has actually forced the architect to exhaust every means of expressing his ideas of beauty. By working with the color consultant, he is able to exploit this sought-for beauty through color. Conversely, if his lines are clean and beautiful but color is lacking, the desired effect may be missed. Too, color

without beauty of design, may be meaningless.

Recently, while in New York, Elizabeth Banning talked with a publisher of architectural books. He said: "Your Far West is architecturally unfair to the rest of the United States. The West—particularly California—is developing a tremendous amount of talent, essentially modern, all benefiting by its exposure to great natural beauty, climatic moderation, abetted by an ambitious, fearless population."

The publisher cited the San Francisco skyline backed up by its two majestic bridges and the massive redwood forests and tumbling snow-fed streams as representing the ultimate in beauty. His comment of the West being "unfair" to the rest of the United States, says Elizabeth Banning, is justification for her contention that color is the predominant factor in contemporary architecture.

**FORD MOTOR COMPANY**

Los Angeles

**Harry T. Miller, A.I.A.  
Architect**

Studying the Red Carrara glass, warm gray and white sash and "eyebrow," colors of the new Lincoln-Mercury assembly plant, are Fred Sach, Ford Motor Company; Elizabeth Banning, Color Consultant; and Wm. P. Neil, Engineer.



She further believes that western architects will continue to lead the way to this new era of beauty extracted through color.

Strangely enough, hard-headed business-minded industrialists today are exhibiting the liveliest interest in the use of color in warehouses, factories and stores. After several studies of color and its effect on the employee, they have found that color has a great importance upon fatigue, cheerfulness, absenteeism, and more important to him, upon increased production and decreased accidents.

The work of the color consultant goes hand in hand with the work of the architect. One complements the other. To extract the best effect from design and lend impact to the completed project, the color consultant works with the architect from the inception of the plan to its completion. A Color Plan includes the specification of the color for the

exterior of the building whether it be paint, tile, concrete, modern glass, or any other structural medium. It includes the color for the floors, walls, ceilings, furniture and fabrics incorporated in the plan. During the entire process, the color consultant strives to visualize the drama inherent in the plan and to implement it with deep and important color. It goes without saying, the Color Plan should always be approved by the architect before the client sees it.

The busy and successful architect normally is unable to devote sufficient time to a comprehensive study of the complexities of modern color planning. However, by consulting a color expert he not only conserves his own valuable time, but also avails himself of the services of a professional technician in the field of color.

A typical example of the work of the architect-

## SAN FRANCISCO MUNICIPAL AIRPORT

Wayne W. Gray, United Air Lines Designer at left; Elizabeth Banning, color consultant, and David C. Patrick, manager Technical Service Dept. of W. P. Fuller Paint Co. view plans of new United Airlines terminal at the San Francisco municipal airport.

In the background is a mobile scaffolding mounted atop a pickup truck which enables the painters to move around quickly.

*United Air Lines Photo*





**UPPER:** Striking interior of the new Frank Werner Store, San Francisco, showing use of full length drapes as integral part of inter-departmental design.

color consultant team was demonstrated in Los Angeles recently. A client had asked his architect to use white as the predominant color of his new restaurant in Hollywood. Before the plans were completed, however, the owner was impressed by results achieved in a restaurant similar to his own through the use of color. As a result, he asked his architect to use color in the interior color which would impart individuality. The architect immediately consulted Elizabeth Banning. Together they devised a plan calling for the use of hand-made cream tiles of a soft grey-green for the floor and a projection of the color over the wall area. The magic touch of individuality was reached with murals depicting the history of the establishment. The result was startlingly beautiful and the public responded to it with an enormous and continuing patronage. In this instance, what might have been a time-consuming problem for the architect was solved with the assistance of a craftsman scientifically versed in the use of pigments. The architect witnessed the enrichment of his creation through the simple expedient of introducing the services of a color consultant to his problems in color. And, it paid dividends to the architect. The client was delighted with the finished plan and the public's response and immediately retained the architect for a second project.

The study of color is a relatively new develop-

**BELOW:** Coordination of Architect, Color Consultant, and Designer is evident in this view of the Frank Werner Store.



**Moulin  
Studio  
Photo**

ment, according to Elizabeth Banning, and most architects have not had any intensive formal training in the subject. For example, when Elizabeth Banning approached the Chicago Art Institute and expressed the wish to study industrial color design, the mixing of pigments, and the use of color in industrial work, she was told that such work was being accomplished not at the Institute but in Paint Laboratories. But today that is an entirely different story—the Chicago Art Institute has the most advanced course in Color Design with an enrollment of students numbering in the hundreds. By investigation Elizabeth Banning found that a good spot to study color in the laboratory was in Germany so she went to Coblenz. For two years she worked in dungarees mixing paints. Since then, upon her return to the United States, she has done considerable pioneering in the color field in this country.

Elizabeth Banning would be the first to say that a great deal of nonsense has been written about color and a great many false premises have been made with respect to color and its effect on emotion. Any color, she says, can be "busy" and "violent" or "quiet" and "subdued," even insurgent red. Contrast is the flux that tames and checks, or warms and vitalizes. The color consultant merely offers the architect a broadened point of view on range, consciousness and utility. The generally accepted uses of commercial paint gives way to a better understanding of color and finishes. The architect working with a scientifically-trained color consultant furthermore acquires a professional knowledge of techniques required in the use of caseins, oils, lacquers, varnishes and recent developments in synthetic pigments.

With the aid of the color consultant, the architect keeps abreast of the most recent progress in color but he does so without robbing himself of valuable time. His visualization of an interior, precisely as he wants it is obtained smartly, promptly and with good taste in the color consultant's laboratory. And the reward to the architect, is greater earnings through an enhanced reputation.

On the industrial scene, Elizabeth Banning thinks Southern California is destined for leadership. Reportedly, it has the largest industrial acreage in the world. During this year building permits total-

ing \$200,000,000 have been applied for. The ultimate plan is to make Southern California not only the most productive industrial region in the world but also the most attractive. On its way to development is a Southern California industrial area where every factory must have attractive architectural style and occupy a site with ample space for landscaping. And, an architectural committee has been set up to approve the factory designs.

Elizabeth Banning and Architect Harry Miller, of Wm. P. Neil & Co., Los Angeles, are taking part in this vast program. For the past eight months they have been collaborating on color design for the Mercury-Lincoln Assembly Plant of the Ford Motor Co., one of the world's largest assembly plants. They are also implementing plans for the Los Angeles' branch of the giant Minnesota Mining and Manufacturing Co. which among other things, controls the manufacture of scotch tape. The Color Plan for this development includes a plan for the exterior as well as the interior where every working space has been carefully planned for modern color.

Finally, but probably most importantly, the public is eager today for color change. There was a time when an interior was completed, painted and the paint job lasted five years. If monotony was recognized, it was expected that all concerned would meet it with stoical resignation. However, through its buying power the public has since registered its disapproval of monotony. One alert restaurant organization has evaluated this desire for change and regularly schedules frequent changes of Color Plans. Other up-to-date firms are going even further and they repaint their interiors seasonally. Executives, too, are insisting upon the use of color in what were once drab offices as an escape from this same monotony. On every hand there has been enthusiastic reception of this new concept of color in architecture.

The color consultant's service, essentially, offers the busy architect these three advantages: (1) It helps him extract the maximum beauty from his modern designs; (2) It saves his time by giving him expert help throughout his planning; and (3) It makes the result of his plan more distinctive and crowns his hard-won labor with greater appreciation measured in new assignments.



AMINISTRATION BUILDING . . . East Exposure

# ROCKY BUTTE JAIL

Multnomah County  
Portland, Oregon

A. J. DREYER, Architect

A recent State Legislative Report gave Multnomah county's Rocky Butte Jail the highest rating for the state, while the Federal Bureau of Prisons, department of justice, rated it among the top 12 or 15 jails of its kind in the nation.

The jail averages about 250 prisoners, including Federal, but has no juveniles.

It is outstanding for its cleanliness and sanitation well equipped laundry where all bedding, towels and prisoner's uniforms are laundered regularly; ample bathing, washing and toilet facilities; well equipped kitchen and hospital.

John H. Matthews is superintendent, and Martin T. Pratt sheriff.

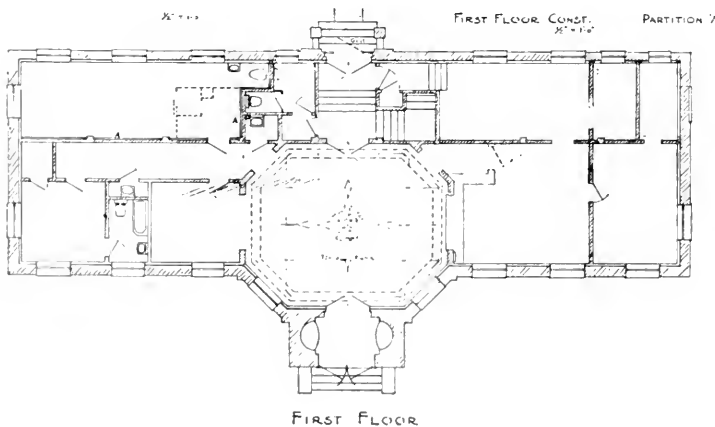

**FIRST FLOOR PLAN** of the new Administration Building which forms a portion of buildings surrounding a large courtyard.



# . . . ROCKY BUTTE JAIL

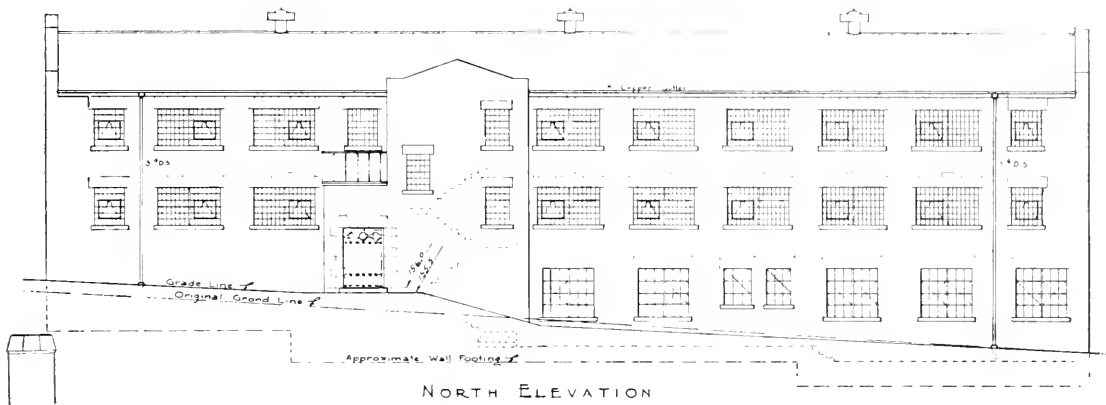

**NORTH ELEVATION** showing the original ground line, the grade line of the Administration Building and the approximate wall footing.

**LOBBY** of the Administration Building showing the attractive entrance hall of the stone structure. The inlaid stone floor includes a terrazzo county emblem. At rear is reception desk, while the lobby opens to the inner court as well as the front.





**PORITION OF DORMITORY**  
designed for maximum in  
cleanliness and sanitation.  
Individual lockers are provided.

**LAUNDRY (below)** is well  
equipped providing facilities  
for all institutional  
washing with prisoners doing  
the work.

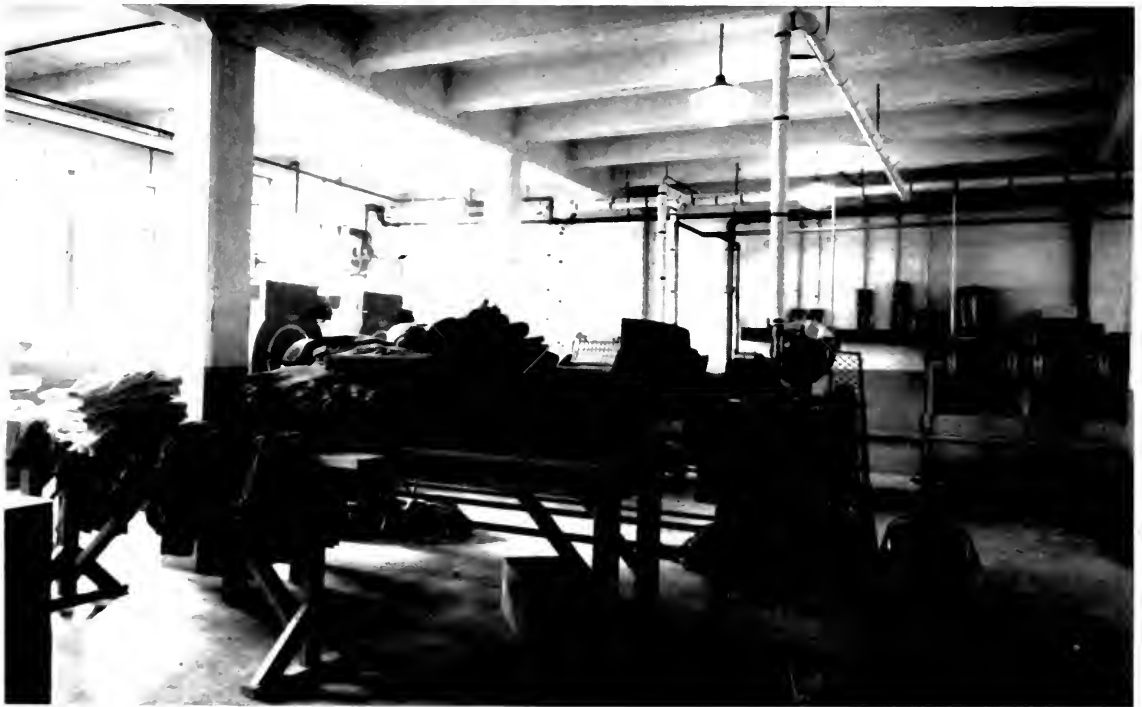

**CORNER OF DINING HALL**  
where cafeteria meals are  
served, each man allowed  
as much food as he wants  
with the exception of meat  
and desert.

**KITCHEN** in women's quarters where some meals are prepared. All of the most modern equipment has been provided.



**DAY ROOM** of the women's quarters where rehabilitation program is conducted.

**LOBBY** in the women's quarters. The entire section is separated from the rest of the jail.



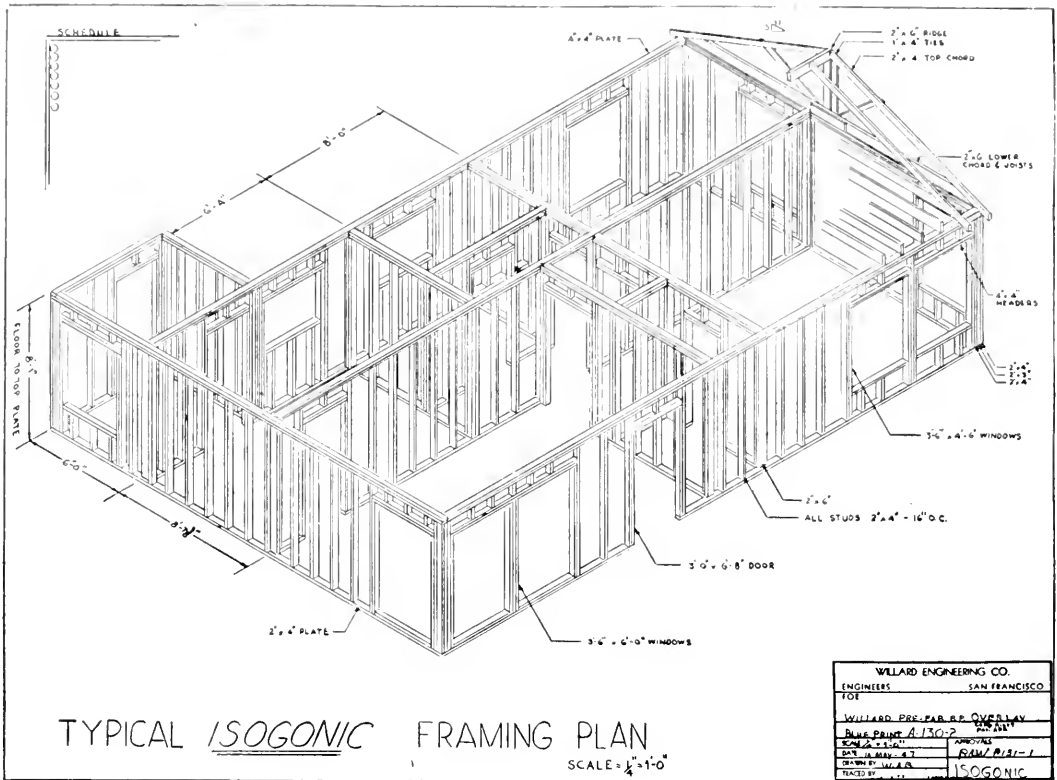

# Isogonic Drafting

## A New Tool For The Architect

By **SIBLEY S. MORRILL**  
Willard Engineering Co.

While the advantages of using Isogonic drafting in the preparation of architectural plans are not as obvious as in machine design, shipbuilding and other fields, they are nonetheless both very real and very great.

Why this is so consists of two main reasons: The certainty that the number of interferences so often found in blueprints prepared in the traditional way will be eliminated before the plans leave the drawing board; and the great increase in readability of the plans when they are given to the workmen.

To appreciate the truth of this it is essential to know precisely what Isogonic drafting is.

Briefly, Isogonic drafting, developed by Nelson E. Bohall of San Francisco, is a method of making three-dimensional engineering drawings, in scale, and which contain all pertinent data.

Though the Isogonic is an outgrowth of the Isometric system, employing the same three axes of projection, it differs so widely from the Isometric that it forms a highly practical—indeed, in the opinion of many, the most practical—method of making most kinds of working drawings.

Heart of the difference between the Isogonic and Isometric lies in the way in which the angles between the three axes of projection are regarded. In the Isogonic, the angles between the arms of the

Y are considered as being in fact 90 degrees each instead of the 120 degrees as traditionally interpreted. In other words, the angle shown on the drawing is considered as having the same value as that on the corresponding part of the object itself. Hence the name Isogonic meaning having equal angles.

Odd as such a concept may seem, the fact remains it works so well that even with the most complex objects it forms a similar way of making more readable plans than any other method.

Further, the Isogonic drawings are self-checking in that the draftsman can immediately see—cannot help seeing—any interferences as they arise.

Because of this advantage of Isogonic Drafting in dealing with complex drafting problems it forms a most important technique for the architect who will use it. While many plans which an architect is called upon to make are relatively simple, it is equally true that he often has to prepare highly complicated layouts. Many office buildings and factories for example, in fact, most special purpose buildings as they might be called are frequently as complex as some of the more intricate of the problems in machine design. And as all architects

and builders know, increased complexities mean increased chances of interferences which may not be discovered until actual construction is under way, a condition which necessitates the use of red ink on the profit and loss sheets rather than the profitable black.

A case in point is that which occurred recently in the San Francisco City Engineer's office during the drafting of piping layouts for the new Richmond-Sunset Sewage Treatment Plant. To test the effect of three-dimensional plans on workers' speed in installing the complex piping system, it was decided to furnish the workers with Isogonic drawings, and a draftsman was given a set of orthographic prints to convert into the Isogonic.

In making the conversion, however, use of the self-checking Isogonic projection revealed the existence of several interferences in the orthographic plans themselves. Possible as it is that these interferences might have been discovered before actual construction had got under way, if the conversion to Isogonic had not been ordered, the probabilities are that they would not have been. In any event, the interferences were discovered as related above and a considerable

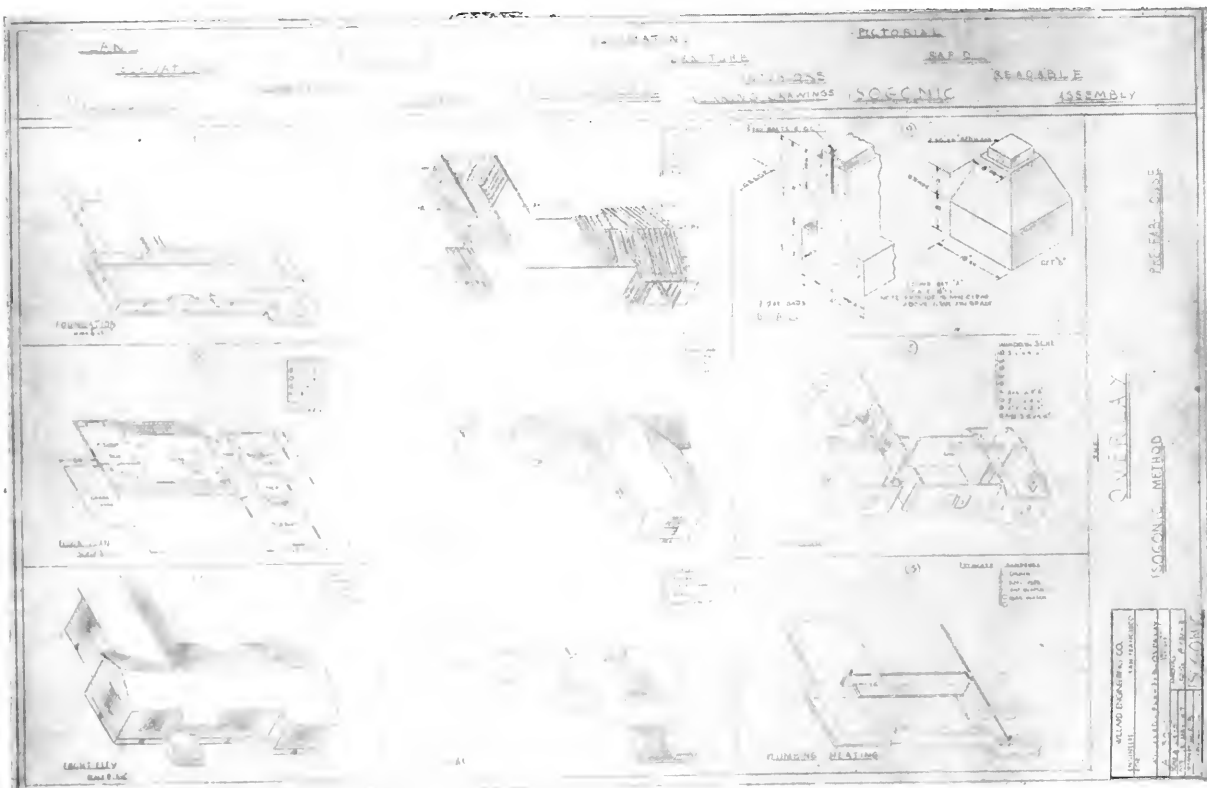

**OVERLAY BLUE PRINT**

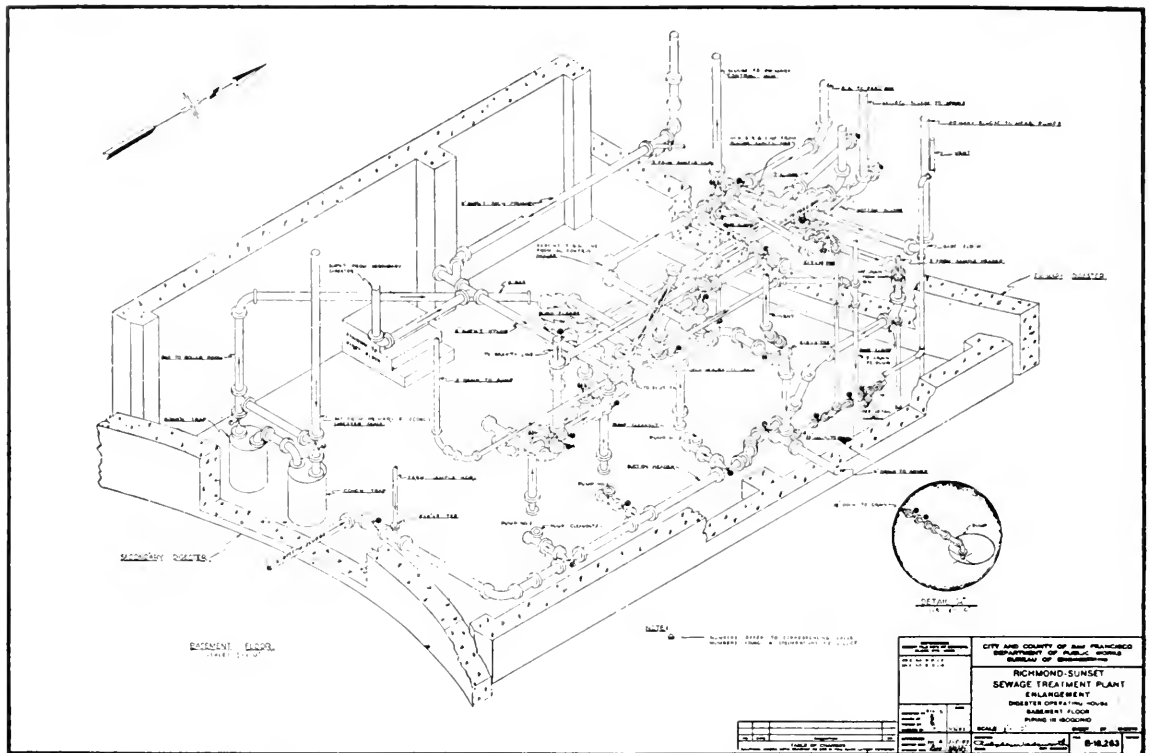

**RICHMOND-SUNSET SEWAGE TREATMENT PLANT . . . Basement Floor**

amount of money was saved as a result.

Yet another case is found in the experience of the Willard Engineering Company of San Francisco, whose chief draftsman, W. Boussard, states that "use of the Isogonic projection is now standard procedure on all complex drafting problems here because of its assured detection of interferences."

Incidentally, this is as good a place as any to point out that the advantages of Isogonic in checking for interferences are not confined to those occurring within a single system. It is also possible to check for interferences between different systems.

How this is accomplished is through use of what is known as the overlay. The overlay consists of a series of related Isogonic drawings made on transparencies, each one in register with all of the others. For an architect such an overlay might compose a series showing the floor plan, framing, plumbing, wiring, heating and ventilating systems. With each of them shown in a different color, it is easy to check—two at a time—for interferences between all the systems.

But though the discovery of interferences on the drawing board is a dramatic advantage of Isogonic drafting, the advantage of greater construction speed through improved ease of visualizing what is to be constructed is fully as important.

Architects and builders know that the more unusual a job the more time must be used in interpreting blueprints. Because the traditional blueprints are made in two dimensions only, it is imperative that they be translated in the mind of the workmen into three dimensional ideas before they can go ahead with their work. On a simple job this translation is automatic for the foreman or skilled worker, but on the more complex job a considerable amount of time-consuming thought is required. And even then it often happens that a mistake is made—sometimes through misinterpretation, sometimes through an error in the original plans—which involves actual waste of material as well as wasted hours.

Obviously if the workman is using a three-dimensional plan, no act of translation can take

(See Page 36)



MAIN FOUR-STORY LABORATORY BUILDING

Barry Evans, Photo

# Research Laboratory Completed for Pabco

## Emeryville, California

Completion of the new Research Laboratory at the Emeryville plant of The Paraffine Companies, Inc., provides the West Coast with one of the largest and most completely equipped building material research centers in the world. Extensive additions and general improvement in research facilities have been effected at an expenditure of well over a half-million dollars.

The four-story, Research Building houses several groups of laboratories; a library with a compre-

hensive collection of technical journals and books; executive offices and a well-ordered storeroom. Important units include an air-conditioned conductivity room equipped with machinery for testing the resistance of material to heat and cold; an air-conditioned micro-analytical room and a weatherometer room which affords an accelerated method of testing the resistance of products to exposure.

In addition to the latest, most up-to-date standard



**View of organic research laboratory, one of the many specialized centers within the Pabco Research Building. Shown on left is instrument panel of equipment for studying the processing of asphalt and pitch.**

equipment found throughout PABCO's Research Laboratory, special machinery designed to the company's specifications has been installed. Pilot equipment simulating manufacturing equipment has been set up to aid in studying product quality and production methods through actual small scale manufacture.

#### **Staffs of Chemists Doubled**

In the expansion move, The Paraffine Companies Inc., has more than doubled its staff of scientists and is engaged in a continual search for men with outstanding qualifications. The firm has attracted a group of chemists and chemical engineers from every section of the United States. The staff members hold degrees from 24 American and foreign universities, and they participate in the activities of 19 different scientific and technical societies.

Dr. A. M. Ersine, Director of the Research Division, is a graduate of Cornell University and has had extensive academic and industrial research experience. The company retains Dr. Ludwig Rosenstein as consultant and advisor. Dr. Rosenstein, a graduate of the University of California, is nationally recognized as a consultant in petroleum and other fields.

#### **Research Spearheads Production at Paraffine**

"The Laboratories will spearhead Paraffine's efforts to produce new and better materials for

housing America's families and industries at lower cost," Company President W. H. Lowe declared in a recent statement.

"Development of more attractive, durable and economical materials for housing of the future will come from scientists' test tubes and pilot plant equipment," Mr. Lowe continued. "Through their technical skill, research will develop new and better building materials and processes for manufacturing them so that they can be made available to the consumer at constantly lower costs."

"The Paraffine Companies believe that our progressive Research Program has been our greatest aid in expanding our markets," President Lowe said. "Research has enabled us to compete successfully with other areas despite our high labor and transportation costs."

#### **Only Part of Program**

Plans for the expansion started in April, 1944 and completion of the Laboratories, with its exacting structural and installation requirements, has taken more than a year and a half. Design and construction of the laboratories was under the direction of Leland S. Rosener of San Francisco, the firm's consulting engineer.

The opening of the Laboratories marks completion of that part of the Company's 11 million dollar construction expansion program now underway.



Address by

# James W. Follin

Assistant Administrator

FEDERAL WORKS AGENCY

Delivered October 2, 1947 Before Members

CALIFORNIA COUNCIL of ARCHITECTS

At Annual Meeting - Catalina Island

**SUBJECT: "Metropolitan Planning and Urban Redevelopment—  
What About Them?"**

The title of my little talk might be taken to indicate a certain skepticism. My purpose rather is to discuss a few of the numerous questions which arise when mention is made either of metropolitan planning or urban redevelopment, to say nothing of what occurs when the two are brought together.

Metropolitan planning has been a matter of public discussion for much the longer period, but urban redevelopment has come into prominence in a rather surprising way recently. Since 1941, nearly half the States and the District of Columbia, have enacted urban redevelopment laws of one kind or another. Conferences of associations related to any aspect of building or development in urban areas invariably have urban redevelopment on their current programs! It has become, in short, a matter of widespread interest.

### **Urban Growth and Urban Decay**

In a relatively short time the United States has changed from an almost primitive agricultural economy to the industrial giant of the world. When the first census was made in 1790 less than 5 per cent of our population lived in communities of 2500 or over, the census definition of an urban community today. The whole country had only 4,000,000 inhabitants then.

Fifty years after that first "inventory" of our people, there still was no Chicago. A stockaded fort was there on the lake, plus a trading post and a few so-called farms. A hundred years later, however, the city's boundaries alone enclosed nearly the 4 million total of 1790. Today, Chicagoland, the metropolitan area, extends into three States.

Chicago is only one of more than a hundred cities the Census Bureau now calls metropolitan. Technology, and chiefly machine technology, has made the metropolitan city possible. Techniques of manufacturing, the rail, highway, water and air transportation have transformed a small fraction, about 2 per cent of the abundant land of this country, into the cities, and has expanded them and maintained them. More than half our people live in urban areas and the proportion is increasing.

People, lots of them and all kinds, have been at the bottom of the phenomenal growth of America and its cities. Our skilled and energetic citizens have erected the industrial colossus of the United States.

Migration from abroad was the most powerful factor in our growth throughout our early history. An enormous population increase accompanied the migrations. This natural increase has continued but it has recently started to taper off, to decline in the rate of its increase.

The westward migration from Europe populated the early States. Successive waves of people, to the present day, mostly traveling from East to West, have created your land-rich and population-rich State of California. Population growth continues to be a primary factor in California's development. An expanding market for the goods and services of your communities is a certainty. The new people, whether born here or elsewhere, require the products of your factories, shops, and offices; also the networks of public works and services provided by the public authorities.

Here in California, as elsewhere, the cities are bursting their seams. The new families, as well as old families from the congested older sections of your still young metropolitan centers, seek today an enormous number of homes. They are searching for them in locations where there is a fair-sized plot of land, some open space and a California view. They demand modern means of transportation and up-to-date highways.

The cities everywhere are opening up and spreading out. Some aspects of this process increasingly have caused concern. The typical central city throughout most of the country now loses residential and industrial population steadily to its suburban areas. This is both alarming and costly to certain individual and institutional property owners, to investors and to the municipal authorities alike. The city recognizes that public services must be maintained, but it sees the tax revenues to support them declining. Those who remain in the city to live and do business are penalized.

Decentralization is causing financial headaches in the cities and the universal urban disease called "blight" is causing trouble nearly everywhere. Considered together they explain much of the very general and considerable interest in metropolitan planning, and in urban redevelopment.

I admit that in listening to the talk one hears nowadays and in reading portions of the five-foot shelf on city problems of today, my reactions do not always follow the standard pattern. The chronically worried note that is so often struck frankly does not move me to feel as bad as other citizens apparently do. Cities seem to me to have some achievement to point to even if they are still far from perfect.

It seems to me no mean achievement that all Chicago was built in about one century. I know it is smoky and windy and has too many railroad tracks, but there it is and you must admit it is quite a lot of city for three or four generations to have put together.

Consider how fast we built these cities, yours too. Your metropolitan cities and smaller communities, urban and rural, are about the youngest of the lot. We built these cities of ours in a hurry and not always of the best materials. We had few architects and fewer engineers until very recent times. We paid a lot of attention to building factories, stores, railroads; lately we have done much

about highways and airports. We had to work in these cities while we lived in them. We didn't do them over every few years, because we just couldn't afford to. Besides we didn't have time. We were expanding, expanding, expanding. We had all kinds of fish to fry. We had to build commercial, industrial, residential sections, because the people were coming all the time.

Now our continental territory is about opened up if not all settled. Migration from outside is down to a trickle. We are pretty big in land and people and fairly prosperous. We extended ourself somewhat during the war and were surprised at our own strength.

My point is this: decentralization—wasn't it to be expected? This blight? Construction isn't expected to last forever. Wasn't it largely inevitable that the cities would expand and parts of them would wear out? Our villages became towns, the towns turned into cities and the cities have become metropolitan centers mostly since grandfather's day.

Grandfather's original plant expanded too. First it was down on the river, close to the center of things. It's not there now, it's decentralized. The people who run today's plant no longer live downtown either. Everything in the town has changed including the people. Water wheels were supplanted by electric generators, and maybe these will give way to atomic turbines. Transportation started at walking, switched to horseback, then to wagoning, railwaying, street-caring, automobiling and now we are expanding our airwaying.

There's a lot of decentralizing in what's happened since granddaddy first set up in business. The cities were very much a part of what was happening. They have been through a lot—these cities. Take the matter of land too. Take the street system, the gridiron plan laid down long ago. We don't use land in cities now as we did then. There are too many intersections in these gridirons. The blocks are too short for the automobile. A driver sadly holds himself down to twelve miles an hour in a 90-horse power machine that would do a hundred—if it weren't for stop signs, street lights, pedestrians, and endless intersections every few seconds.

On these streets inherited from previous generations, as you travel out from the business district, take a good look at the building—in St. Louis, in Los Angeles, in San Francisco. These are the sections the planning office has colored red and

marked with large black letters—**BLIGHT**—on the city's maps. These sections are simply old. Blight may be a disease, but if it is, the disease should be called obsolescence. These old stores, lofts, offices and factories, frame houses, brick warehouses have been with us a long time. We should ask ourselves: Haven't these relics about reached retirement age? When you look again please check on this: Isn't nearly every one of these blight-infected old structures an architect's or a builder's potential commission?

Blight is a replacement opportunity on a vast scale—billions in new construction are ahead in that urban blight. Decentralization and blights are two of the devils that have brought to public attention the urban redevelopment talk we hear.

There has been and will be a tremendous expansion of cities. The census figures tell this story of unsuccessful competition of the older central cities with their suburbs. The older central cities are losing ground in the contest with the new communities on their outskirts. Cities are overflowing their original boundaries. Valuable central cores of cities already have their fill of blight and steadily are given more.

We know we are not going to abandon the cities. The investment, private and public, in streets, sewers, sanitation and all the rest, costly improvements already in place, are one reason we don't take seriously leaving cities to rot. But we are not going to be able to hold people, either residents or business people, in those portions of the cities which increasing numbers of people don't like—if they have any choice in the matter and can move.

The things that force change and growth upon cities are very strong. Property owners, officials and housers combined have so far had no effect upon them—blight and decentralization continue. Urban redevelopers, however, are launching an attack to bring about some changes and improvements in the very centers of our original cities. New layouts for whole sections and new structures, conforming to a city plan are pretty well along. The process they call urban redevelopment begins in the old, mostly downtown sections. The changes are to give protection from noise and congestion. Dilapidation and obsolescence, old streets and old buildings—they propose to eliminate them. New residential neighborhoods, complete with all modern conveniences; safe streets, shopping centers, schools to compete with the suburban ones—these are planned.

But metropolitan planning, some authorities are

insisting, will have to go hand in hand with urban redevelopment if the old city is to be renewed and is to be able at the same time to meet the expenses of the operation. Central city suburbs old and new and some to come, are an interdependent whole. Because city and suburbs are related physically, in economic or finance aspects, in community purposes generally, the parts of the metropolitan city will have to get together.

The older community, losing its people and their taxes, cannot afford to renew itself, cannot provide modern transportation, cannot continue to support a combined business, industrial, public works and services center unless the metropolitan populace as a whole that has the use and advantage of all these things also plays on the team, shares costs along with benefits.

### Metropolitan Planning

It is not realistic to expect that metropolitan planning is going to come in everywhere overnight, no matter how clear the need nor large, either the immediate, or what is more likely, long-term, benefits of such planning to the community. While it is quite well recognized by a number of people that water supply, sanitation, highways and transport operate without paying much attention to municipal boundaries, the general public moves mighty cautiously toward the idea that the big city and the little cities should pool their resources in order to do a better job. More are convinced than admit it. Even fewer are ready to make the first move!

While we do not yet have metropolitan planning, in the sense that the built-up central city and related communities on its periphery join officially in an overall plan, progress has been made. On the whole although it is not yet much to shout about.

Still there is cooperative planning in many places. Milwaukee City and County are clearing their plans with each other and adjusting differences as they go. Los Angeles city and county have a similar arrangement that dates back many years, I believe. Louisville is perhaps unique in its Area Development Commission—created under State law—on which city and county officials and private groups are represented in the same agency.

Special purpose public authorities, which often plan for large areas but usually for a single function, are familiar. These cut across municipal boundary lines, build and operate sewer and water systems, port facilities, airports and other terminals. This is not real metropolitan planning but a kind of limited metropolitan government.

It has been said that real metropolitan planning, preparing the coordinated land-use scheme of public facility routes or sites and the private developments they serve, will probably have to wait for metropolitan government—something even more complex and remote than anything discussed in this paper. An argument usually made for metropolitan government is that there must be power to act and get results. In my opinion we have a long time to wait for cities and suburbs to combine their governments and unite in this sense.

A number of States, among them California, have regional planning powers in their planning laws which permit cities and counties, any combination that wishes to work together, to prepare metropolitan area plans, either jointly or by delegating the planning task to one of their number.

In recent years the number of cities informally and unofficially getting together on metropolitan planning has increased greatly. Local facts are assembled for group study. Private organizations of citizens representing a cross-section of business, industry, professional and civic viewpoints, meet frequently with their public officials in these cities. Official planning is becoming stronger and more influential in these communities. This continuing association of officials, technicians and laymen is given much of the credit.

At a meeting in Washington the middle of last month, called by the U. S. Chamber of Commerce, I attended a series of round table discussions conducted jointly by business men, Federal, State and local officials and city planners. Much of the discussion centered around the topics that are before us.

I found interesting an analogy drawn by one speaker who compared industry and a city. An industrial enterprise would succumb if handled as our cities are run, he stated. When an industry grows out of its clothes, it doesn't continue to live in them. It may endure the discomfort for a while but if the industry is really growing, it finds ways to build a new modern plant, even while it continues to operate and use the old one.

The housing, industry, commerce, education, health and recreation facilities of a metropolitan city are interdependent operations in no ordinary sense—they are mutually supporting and mutually dependent. We need in our communities to provide ourselves with a common plan that serves all of us, in which all of the separate parts are fitted together. Over the years, private enterprise and the public authorities, building the new urban

plant for living and for work, may proceed even while we are living and gradually replacing the old.

We need to take stock of what we inherited from grandfather and great grandfather. We need to set in motion a community-wide program to replace what has been made obsolete by use. While better techniques of designing and building have been coming forward steadily, ways of doing business, of maintaining health, of educating, and of living in general, have changed and in many ways improved, we still use many of the old fashioned facilities. It is time to put present needs and present day techniques together. The communities, if we are to judge by the interest in metropolitan planning and urban redevelopment, are striving in many parts of the country to rise to this challenge. California's towns and cities are prominent among them.

## Urban Redevelopment

While urban redevelopment still is largely associated in the public mind with housing it means far more than housing. Industrial and commercial decay are widely prevalent in the blighted areas. Streets and highways are outmoded and the new superior design highway and street plans should replace and are replacing the old. City halls and courthouses, Federal and State office structures are needed. Urban redevelopment, therefore, is also public works and community facilities.

The narrowing of urban redevelopment to housing probably dates back to activities some years ago when public housing commenced its attack upon slums in a number of cities. Private enterprise, however, as early as 1935, was at work on the problem. The surveys of the period showed the alarming extent, the costs, and the waste of blight.

Federal Housing Administration, the Government agency that insures mortgages of private home finance institutions, put a small staff to work a year or two before the War to study the effects of its policies in cities and the possible effects of blight and decentralization on its nation-wide operations and program.

The Urban Land Institute and the U. S. Chamber of Commerce Construction and Civic Development Division have long been actively in the field and contributing to the public's information and understanding of urban blight and decentralization.

Private enterprise and Government have sought together methods for dealing with the critical physical and financial conditions in urban com-

(See Page 34)



**Arizona Chapter:**  
 James Macmillan, President; Arthur T. Brown, Secretary, 740 N. Country Club Road, Tucson, Arizona.

**Central Valley of California:**  
 Herbert E. Goodpastor, President; Frank V. Mayo, Secretary, 307 Exchange Building, Stockton 2, California.

**Colorado Chapter:**  
 Raymond H. Ervin, President; James M. Hunter, Secretary, 2049 Broadway, Boulder, Colorado.

**East Bay Chapter:**  
 A. Lewis Koue, President; James H. Anderson, Vice-President; Loy Chamberlain, Secretary; Chester H. Treichel, Treasurer, Office, 3933 Piedmont Ave., Berkeley, California.

**Montana Chapter:**  
 Ralph H. Cushing, President; H. C. Cheever, Secretary, Montana State College, Bozeman, Montana.

**Northern California Chapter:**  
 Hervey P. Clark, President; Lester Hurd, Vice-President; Ralph Pollack, Secretary; William C. Ambrose, Treasurer; 605 Market Street, San Francisco.

**Oregon Chapter:**  
 Walter E. Church, President; Frank Roehr, Secretary; Office 619 Builders Exchange Bldg., Portland 4, Oregon.

**San Diego Chapter:**  
 H. Louis Bodmer, President; Louis J. Gill, Secretary, 203 Granger Building, San Diego, California.

**Santa Barbara Chapter (California):**  
 Chester L. Carjola, President; Robert I. Hoyt, Secretary, 116 E. Sola St., Santa Barbara, California.

**CALIFORNIA COUNCIL OF ARCHITECTS**  
 Vincent Palmer, President; Andrew Haas, Vice-President; A. C. Martin, Jr., Secretary-Treasurer; 369 Pine St., San Francisco 4.

**Southern California Chapter:**  
 Adrian Wilson, President; A. C. Martin, Jr., Vice President; Walter L. Reichardt, Secretary; George E. Gable, Treasurer; Chapter Headquarters, 3757 Wilshire Blvd., Los Angeles 5, California.

**Spokane Chapter (Washington):**  
 Noel E. Thomson, President; Kenneth D. Storment, Secretary, Hutton Building, Spokane, Washington.

**Utah Chapter:**  
 George Cannon Young, President; Theodore R. Pope, Secretary, 29 South State Street, Salt Lake City 1, Utah.

**Washington State Chapter:**  
 Clifton J. Brady, President; Arrigo M. Young, Vice-President; John Richards, 2nd Vice-President; Ralf E. Decker, Sec.; Waldo B. Christenson, Treasurer, Office 1411 Fourth Avenue Building, Seattle 1, Washington.

**Hawaii Chapter:**  
 Kenneth W. Roehrig, President; James Morrison, Secretary, 334 Federal Bldg., Honolulu, T. H.



**NEW EAST BAY CHAPTER A. I. A. Organization Dinner.** Seated at the speakers table are Wm. McGrath, State Builders Exchange (left to right); Jack Y. Long, Structural Engineers Association of California; Hervey P. Clark, President Northern California Chapter A. I. A.; Albert R. Hunter, Director East Bay Chapter; Oscar Price, Director East Bay Chapter; James H. Anderson, Vice-president East Bay Chapter; Earl Heitschmidt, Regional Director, A. I. A.; Louis Koue, President East Bay Chapter; Loy Chamberlain, Secretary East Bay Chapter; Chester Treichel, Treasurer East Bay Chapter; Fred L. R. Confer, Director East Bay Chapter; Andrew Haas, California Council of Architects; Chas. Nicholas, President Northern California Producers Council; Bernard Wistletier, Landscape Architects Association; Wm. Hague, Associated General Contractors; Cliff Dorwin, Oakland Builders Exchange; and Mrs. Elizabeth K. Thompson.

**EAST BAY CHAPTER A. I. A.**

Formation of the East Bay Chapter of the American Institute of Architects as an integral part of the California Council of Architects was completed at a banquet in Berkeley on October 9, 1947, when a Charter from the national association was presented to the new architectural organization.

In making the Charter presentation to A. Lewis Koue, president of the East Bay Chapter, Earl T. Heitschmidt, Regional Director of the A. I. A., and prominent Los Angeles architect, pointed out the opportunities which were present in California because of its continual growth and development.

Members of the Chapter were urged by Heit-  
 (See Page 35)

# WITH THE ENGINEERS

Structural Engineers Association of  
Northern California

William W. Moore, President; John A. Blume, Vice  
President; Franklin P. Ulrich, Treas.; G. A. Sedg-  
wick Sec.; Wm. H. Popert, Consultant; Office, Room  
712, 57 Post St., San Francisco, Phone SUTter  
1-5474. DIRECTORS, Mark Falk, M. V. Pregnoff,  
and R. D. Dewell.

American Society of Civil Engineers  
San Francisco Section

Sidney T. Harding, President; Lawrence A. Elsener,  
Vive President; John E. Rinne, Secretary-Treasurer,  
225 Bush Street, San Francisco 20.

Puget Sound Engineering Council  
(Washington)

R. E. Kister, A. I. E. E., Chairman; E. R. McMillan,  
A. S. C. E., Vice Chairman; L. B. Cooper, A. S. M.  
E., Secretary; A. E. Nicherson, I. E. S., Treasurer;  
Offices, L. B. Cooper, c/o University of Washing-  
ton, Seattle 5, Washington.

---

## AMERICAN SOCIETY OF CIVIL ENGINEERS—San Francisco Section

A recent technical program was devoted to the  
subject "San Francisco's Traffic and Transporta-  
tion Problems." Taking part were T. J. Kent, Jr.,  
Director of Planning for the City and County of  
San Francisco J. H. Turner, M ASCE, Manager of  
Utilities for San Francisco; and H. C. Vensano,  
M ASCE, Director of Public Works of San Fran-  
cisco.

---

The Spring meeting of the Society for 1948,  
originally planned for Sacramento, California, has  
been tentatively set for Washington, D. C.

---

"THE TRANS-ARABIAN PIPE LINE" was the  
subject of an illustrated talk by Sidney P. Johnson,  
Mechanical and Electrical Engineer with the Stand-  
ard Oil Company and Consultant to the Trans-  
Arabian Pipe Line Company, at the October 21st  
meeting.

Johnson described his experiences and obser-  
vations as a member of the reconnaissance party  
which traversed the route of the line.

---

CARL NORWICK, Pacific Telephone & Tele-  
graph Company recently spoke before the Junior  
Forum on the subject, "Co-axial Cable Develop-  
ment".

---

The first Annual Party since the War was held  
October 3 at the Officers' Club on Treasure Island  
with L. Harold Anderson in charge of arrange-  
ments. More than 110 members, wives and guests  
attended.

---

NEW MEMBERS: John G. Little, I. D. Raffin, W.  
B. Berger, and J. R. Burnham, Associate Members;  
W. A. Buehl, J. C. Vandermeij, J. L. Durkee, and

J. D. Naillon. The subscribing membership of the  
Section now exceeds 868.

---

## STATE BOARD OF REGISTRATION

Governor Earl Warren has appointed L. M. K.  
Boelter, Chemical Engineer W. H. Geis, Petroleum  
Engineer; R. W. Sorensen, Electrical Engineer;  
and G. L. Sullivan, Mechanical Engineer, as the  
four additional members of the new seven man  
Board of Registration for Civil and Professional  
Engineers.

They will serve with Paul E. Jeffers, Asa G. Proc-  
tor, and A. V. Saph, Civil Engineers.

---

## AMERICAN SOCIETY FOR METALS PUGET SOUND CHAPTER

In a recent talk before members of the Chapter,  
Mr. A. J. Langhammer, President, Amplex Division,  
Chrysler Corporation, explained a 90% copper and  
10% tin powder mixture for gears which is com-  
pressed into the desired shape and sintered, re-  
sulting in a sponge metal.

The metal is then impregnated with oil and  
becomes a self lubricated, oil cushioned bearing.

The speaker also pointed out that machine parts  
made by powder metallurgy are replacing die  
castings, cast iron parts and stamping.

During the war powder metallurgy was used  
in the mass production of many precision tools  
such as micrometer frames and tool makers V  
blocks.

---

## SANTA CLARA UNIVERSITY

Eugene Campi, has been elected president of  
the student ASCE Chapter at Santa Clara Uni-  
versity for the Fall semester. Other officers in-  
clude: Joseph Patten, vice-president; Joseph Rech-  
enmacher, secretary; and Edward Vadnais, treas-  
urer.

---

## OPEN NEW OFFICE

George E. Garthorne, A. L. Buonaccorsi and  
Jos. E. Murray recently announced their associa-  
tion in the practice of Electrical and Mechanical  
Engineering with offices at 1095 Market Street,  
San Francisco.

---

## RESEARCH ADVISORY BOARD ESTABLISHED

Creation of a Building Research Advisory Board  
under the chairmanship of Dr. Frank B. Jewett,  
has been announced by the National Research  
Council.

Dr. Jewett, former president of the Bell Telephone  
Laboratories, Inc., will be assisted by a Board  
comprising twenty leaders in the field of scientific  
research, architecture, engineering, and building  
construction.

The Board's objectives are to serve as a central clearing house for information on scientific research in the building construction industry, to stimulate correlation of research information and coordination of research activities.

Establishment of the Research Board was at the specific request of the Construction Industry Advisory Council.

### ENGINEERS TO HEAR U. C. SCIENCE TALKS

Eleven leading scientists will give eighteen lectures in a unique course on "Modern Physics for Engineers", on the Los Angeles campus of the University of California.

Speakers on the program, being sponsored by the Division of Engineering extension, will include: Dr. Stafford Warren, dean of the U. C. L. A. Medical School; Alfred Banos, associate professor of physics; Dr. F. A. Bryan, associate professor of medicine; David S. Saxon, assistant professor of physics; L. M. K. Boelter, dean, U. C. L. A. College of Engineering; Leo A. Ohlinger, nuclear consultant; J. R. Richardson, associate professor of physics; Morris Neustadt, research physicist; Vern O. Knudsen, professor of physics; Joseph Kaplan, professor of physics; and Chauncey Starr, research physicist.

### ENGINEERING SOCIETIES' BUILDING

A special Building Committee of the San Francisco Engineering Council is being formed to study the possibilities of financing and constructing an Engineering Societies' Building in San Francisco, owing to the limited facilities of the present Engineers' Club.

### STANFORD ENGINEERING FACULTY

C. C. Lomax, Jr., and B. G. Woolpert have been appointed acting assistant professors to the Civil Engineering faculty of Stanford University.

W. K. MacCurdy has been named an instructor, and J. W. Rolston and John F. Brahtz have been appointed acting instructors.

### NEW FACTORIES IN NORTHERN CALIFORNIA

During the past two and one half years more than 1400 new industrial plants have been built or announced for definite construction in northern California, according to Carlton Green, Regional Economist of the U. S. Department of Commerce.

The figure represents 56 per cent of the total for the State.

PROFESSOR Raymond E. Davis has returned to the University of California Campus at Berkeley, following an extended visit to European countries.

## The builder who thinks of tomorrow



### Plans for built-in telephone outlets now

One sure way to provide for your clients' comfort and convenience for years to come is to plan for built-in telephone outlets before construction starts. Here's why.

The location of the telephone can be changed, or additional telephones added without drilling through the flooring or running wires along baseboards.



The convenience of well-placed telephone outlets will be appreciated year after year.

And, built-in telephone outlets add little to building costs . . . much to building value.



Call or dial your local Telephone Business Office. Ask for Architects and Builders Service.

**The Pacific Telephone and Telegraph Co.**



GOOD CONSTRUCTION DEMANDS

3 HINGES TO A DOOR

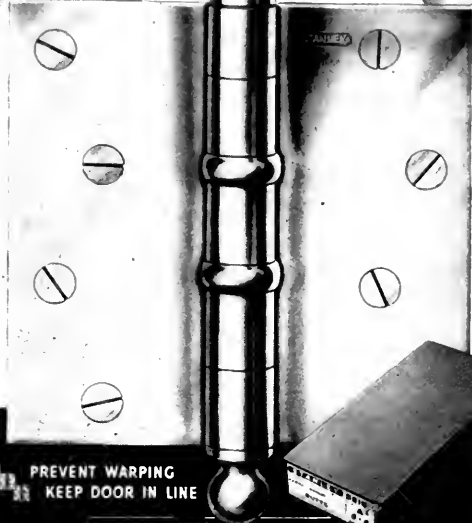

PREVENT WARPING  
KEEP DOOR IN LINE

STANLEY

THE STANLEY WORKS, NEW BRITAIN, CONNECTICUT

FOR BETTER SERVICE

Remember that

KRAFTILE is  
WESTERN HEADQUARTERS

FOR

- ▶ GLAZED Structural Wall Units
- ▶ PATIO Tile
- ▶ QUARRY Tile
- ▶ SWIMMING POOL Overflow Gutter
- ▶ ACID Brick
- ▶ ACID-PROOF Jointing Compounds
- ▶ ACID-PROOF Floor and Tank Construction
- ▶ ACID-PROOF Coatings



- ▶ QUONSET Packaged Steel Buildings
- ▶ STRAN-STEEL Framing

For complete information and prompt service, phone or write

KRAFTILE COMPANY

NILES, CALIFORNIA

NILES 3611

SAN FRANCISCO: 50 Hawthorne Street — DOuglas 3780

LOS ANGELES: 316 E. Commercial Street — MUtual 2411

JAMES W. FOLLIN

(From Page 30)

munities. There has been recognition on both sides of the constructive intent of urban redevelopment, properly conceived, to provide an approach, technical and administrative methods for orderly, progressive renewal of the urban and metropolitan "plant" and ground plan as a whole. Housing is important, but business and manufacturing sections, and public areas are no less so, and must be included.

State laws for urban redevelopment are of three types:

1. Permitting private corporations to engage in redevelopment.
2. Making public housing authorities the administrative as well as the construction agency.
3. Establishing a land agency in local government to administer redevelopment.

California has enacted the third type which is growing in favor. Laws of this character are not primarily housing bills nor are they anti-public housing. Conflicting viewpoints appear best reconciled in them and they provide for a comprehensive attack. The local communities have control, private funds and private enterprise are encouraged to do the job and the public authorities are active partners in meeting public works and public services requirements.

Two of the "private corporations" State laws have been challenged. Illinois' law was declared unconstitutional. The test came on the grant of condemnation power to a private corporation without adequate controls in the public interest.

New York's "private corporations" law was upheld by a vote of two to one, providing a case that is worth study, as the dissenting judge argued vigorously.

In July the Pennsylvania Supreme Court upheld the law adopted in 1945. The Philadelphia Inquirer hailed the case, stating it "provided the most far-reaching action in speeding Philadelphia's vast program of postwar improvements. Pennsylvania and California laws are the third or "land agency" type.

The land assembly power is the chief legal innovation provided by the new urban redevelopment laws. As the new powers for condemning land in large tracts are used it becomes possible for the first time to clear, plan, construct and manage broad-gauge developments of the character which have a unity and logic that accords with present day urban conditions and requirements. The development area is designed as a whole under these laws and must meet certain local standards of adjustment and relationship to the overall plans of the locality.

(See Page 40)



## A.I.A. ACTIVITIES

(From Page 31)

schmidt to "participate in community activities and make the public aware of the architectural profession".

In accepting the Charter on behalf of the architects of Alameda and Contra Costa counties, President Koue, declared the members of his group were well aware of and would accept the many responsibilities being placed upon their Chapter.

Representatives at the Charter Dinner included: Andrew Haas, vice-president California Council of Architects; Oscar M. Price, East Bay Association of Architects; Bernard Wistletier, Landscape Architects Association; Ernest Higgins, California Horticultural Ass'n; J. Y. Long, Structural Engineers Association of California; Sidney Hardy, American Society of Civil Engineers; Clyde Bently, American Society of Heating and Ventilating Engineers; Chas. J. Nicholas, president Northern California Chapter of the Producers Council; Harold W. Smith, president Central California Chapter Associated General Contractors; Wm. E. McGrath, president State Builders Exchange; Wm. E. Hague, general manager Associated General Contractors; Hervey P. Clark, president Northern California Chapter A. I. A., and numerous letters and telegrams of congratulations and best wishes.

Officers and directors of the East Bay Chapter A. I. A. are: A. Lewis Koue, president; James H. Anderson, vice-president; Loy Chamberlain, Secretary; Chester H. Treichel, treasurer; and Oscar M. Price, Albert R. Hunter and Frederick L. R. Confer, directors.

James H. Anderson, vice-president served as chairman of the meeting.

### CALIFORNIA COUNCIL OF ARCHITECTS CATALINA CONVENTION



VINCENT PALMER, President California Council of Architects, and Mrs. Palmer at Producers Council Sportsmen's dinner at recent convention.

## THE MEASURE OF A HOME

The degree to which homes can be truly modern is measured by the convenient, satisfactory operation of their electrical facilities.

Before you complete plans and specifications for new homes, be sure that nothing has been omitted from the wiring plans. Make certain they are adequate for today, tomorrow and ten years beyond tomorrow.

Are there plenty of convenience outlets, plenty of light switches properly located, wires that are large enough to supply all the appliances that will be used during the life of the house?

Adequate wiring costs so little and means so much to the future comfort of your clients . . . as well as to the resale or rental value of the house itself. It is truly the "measure" of the liveability of any home.

Don't handicap homes of the future with wiring of the past. Specify Certified Adequate Wiring in every home you design.

### NORTHERN CALIFORNIA ELECTRICAL BUREAU

1355 Market Street

San Francisco 3

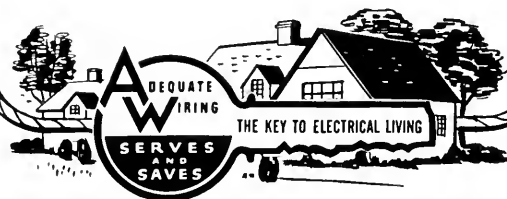

**BAXCO**  
CHROMATED ZINC CHLORIDE

**CZC**

**PRESSURE TREATED LUMBER**  
● **PROTECTS AGAINST DECAY**  
**AND TERMITE ATTACK**

*Specify it in your home*  
*Available through Lumber Dealers*

<p>LOS ANGELES 601 W. 5th Street Phone MIchigan 6294</p>	<p>SAN FRANCISCO 333 Montgomery Street Phone DOuglas 2-3883</p>
--	---

**J.H. Baxter & Co.**

AGENTS FOR WEST COAST WOOD PRESERVING CO. SEATTLE, WASH.

CATALINA CONVENTION HIGH-LIGHT  
CALIFORNIA COUNCIL OF ARCHITECTS



ABOVE: John Hall, President, Producers' Council, Southern California Chapter, and Mrs. Hall. Hall was M. C. at the Sports-men's Dinner.

BELOW: Vincent Palmer, C.C.A., President, demonstrating to Mr. and Mrs. Arthur Frolich, Architect, the confusion caused by inflation.



**ISOGONIC DRAFTING**

(From Page 24)

place. There is no need for it. His powers of visualization are immediately complete and no huddles with the foreman are necessary. Furthermore, because the Isogonic plans are self-checking, likelihood of an error from a mistake in the plans, and thus the probability of wasted material and hours, is still further reduced.

To quote from a report by Charles Trilling, Naval Architect: "in one activity which was converted to the Isogonic an enormous saving in the amount of waste material was effected."—and again—"when the overall time of construction is considered, then the ease, the rapidity, and the accuracy with which Isogonic drawings can be read results in the Isogonic running away with all time saving honors."



**E. K. WOOD LUMBER CO.**

**SAN FRANCISCO** General Offices: No. 1 Drumm Street  
**LOS ANGELES** Office and Yards: 4710 S. Alameda St. — JE 3111  
**OAKLAND** Yards and Wharves: 2111 Frederick St. — KE 24277  
**PORTLAND** Mill Sales Office: 827 Terminal Sales Bldg.  
**SAW MILLS:** Roseburg, Oregon • Reedsport, Oregon  
**RETAIL YARDS:** LOS ANGELES • OAKLAND • ONTARIO • HOLLYWOOD  
 LONG BEACH • RIVERSIDE • TEMPLE CITY • SIERRA MADRE • INDIO • THERMAL  
 LA VERNE • WHITTIER • PASADENA • SAN PEDRO

# IN THE NEWS

## SCHOOL BONDS VOTED

A new grammar school building consisting of 18 classrooms, music, library, offices and lavatories and costing \$175,000 will be built by the Manteca (California) Elementary School District. Frank Mayo and Eric Johnson, Stockton, are the Architects.

## NEWSPAPER RADIO STATION

at Palo Alto, California, is being designed by BRIDGE M. CLARK and WALTER STROMQUIST, Architects of Palo Alto.

## COTTON INSULATION

A new type Cellulite, flame-proof cotton building insulation has been developed by the GILMAN BROTHERS COMPANY of Gilman, Conn.



Called Type-E-Cellulite it has a sturdy vapor seal on one side, and a tough paper covering on the other. Available in standard widths, packaged in cartons for easy shipping, storage, and handling.

## LARGE PROJECT

The David D. Bohannon Company of San Mateo, California, have announced the starting of construction on 54 residences to be built in the Hilldale Tract, San Mateo. Cost of individual homes will vary from \$9,800 to \$13,000 each.

## THREE APARTMENT BUILDINGS

comprising 24 apartments and costing \$170,000 are being built in the Monte Vista Village, Monterey, California. Robert R. Jones, Carmel, is the architect.

**WILLIAMS & BURROWS**, General Contractors, Burlingame, California have been awarded a \$172,750 contract for the construction of six classrooms, kindergarten and offices at the Willow School, East Palo Alto.

*Planned Lighting*



PLANNED LIGHTING for greater efficiency of operation was produced by Smoot-Holman for this new and ultra-modern printing plant of Pacific Press, Inc., Los Angeles.

Smoot-Holman PLANNED LIGHTING may well increase your production and improve your product.

*By*



Offices in Principal Western Cities—Branch and Warehouse in San Francisco

# LANDSCAPE ARCHITECTURE

## Notes of The Profession

ASSOCIATION OF LANDSCAPE ARCHITECTS, SAN FRANCISCO REGION

Vernon Dean, President; Robert Royston, Vice-President; Ned Rucker, Treasurer;  
E. L. Anderson, Secretary, 1736 Franklin, Oakland, California.

### SAN MATEO'S FIESTA AT BAY MEADOWS ARTHUR COBBLEDICK, A.L.A., SHOW DESIGNER

San Mateo county's recent annual Fiesta at Bay Meadows has been judged the most attractive in the history of this colorful event. Those responsible for its success, both amateurs and



**ARTHUR COBBLEDICK**  
Show Designer

professionals under the leadership of Norvell Gillespi, show manager, were too numerous to give full credit.

This year's model gardens contributed much, due to the combined efforts of ten members of the Association of Landscape Architects, headed by Arthur Cobbledick, show designer. Outstanding were the modern gardens designed by Douglas Bayliss, John Boucher and the firm of Osmundson, Staley and Gibson. Most admired was an arrangement of old fashioned perennials for today's garden by Geraldine Scott and Katherine Imlay.

A hobby garden, featuring an aviary, was successfully demonstrated by Rodney Strauss, aided by other landscape architects. In keeping with the theme "Gardens Through the Years" was an exceptionally well executed oriental garden by Ari Inouye and Masaru Kimura.

Equally effective were the amateur gardens planned and executed by the various garden clubs under the general direction of Mrs. Oscar Thayer. Rivalling the floral displays were the agricultural exhibits staged under the direction of Agricultural Commissioner Max Leonard and his staff. Lack of a suitable site or structure in which to stage a really fine show presented a most serious obstacle.

Some degree of success was achieved, regardless, by an effective use of war camouflage netting. Both colored and in its natural state, it served not only as a screen but provided a textured background at low cost.

Recently the San Mateo County Fair Association acquired a permanent site for staging future

Fiestas, just north of Bay Meadows. It is anticipated that when fully developed its buildings and grounds will provide a year 'round center for garden club activities, hobbyists and other recreation purposes.

\* \* \*

HOWARD GILKEY has finished plans for the 1948 Oakland Spring Garden Show and claims that it will be better than ever, with more exhibitors and more spectators. The theme is naturalistic—based upon the California Coast forest lands, from the beach back to the first ridge. No title has been accepted as yet, although the Show dates have been set for April 27 to May 2 inclusive.

Gilkey participated in the two weeks good will tour of Mexico which was sponsored by the Oakland Chamber of Commerce early in October.

\* \* \*

RODNES S. STRAUSS has worked up quite a large business cooperating with G. I's. in their private gardens.

\* \* \*

ECKBO, ROYSTON and WILLIAMS have finished the preliminary landscape drawing on the P. H. A. (Ladera) Project which is located near Palo Alto.

\* \* \*

THOMAS CHURCH spent the early part of October in New York and the East. He is engaged in landscaping the North Shore Center at Beverly, Massachusetts, and the Panamanian Hotel, Panama City. His firm is preparing preliminary plans for a swimming pool and recreational area at Calneva Lodge, Lake Tahoe, California.

\* \* \*

RALPH JONES, LANDSCAPE ARCHITECT, City of Alameda, who was his city's official delegate to the recent American Institute of Park Executives convention, reports that the Master Plan for Alameda parks is not completed as yet, but is progressing. Among preliminary plans for seven of the parks is one for the reconstruction of Washington Park which will include a 66-acre yacht harbor with a capacity for 600 boats; docking and repair facilities, large clubhouse, landscaping, and parking area, along with complete recreational facilities. The plans for Washington Park and the

other six parks for which preliminary plans have been made have not been approved by the City Council as yet. Another park has been approved by the Council and construction is underway. This is an area dedicated to model airplane flying and is adjacent to the Golf course. The construction is continuing as the necessary fill is made, and part of the park is now in use and is proving to be very popular with model plane enthusiasts. Plans have not been made as yet for the last of Alameda's nine parks.

DOROTHY CRAWFORD is now working for the Oakland Planning Commission.

#### ASSOCIATION OF LANDSCAPE ARCHITECTS

The Association of Landscape Architects participated in the banquet recently at which time the new Charter was presented to the East Bay Chapter of the American Institute of Architects.

#### MARIN ART AND GARDEN SHOW

Eckbo, Royston and Williams, Landscape Architects, collaborating with Jacques Schneir and Claire Falkenstein, Sculptors, won first and second prizes for their class in the Show.

Ruth Jaffe, Landscape Architect, collaborating with Blanche Phillips, Sculptor, won third prize.

#### LYNN HARRISS and WM. PENN MOTT OAKLAND PARK DEPARTMENT

Members of the American Institute of Park Executives were recently entertained in Oakland. Bill Mott was on the committee of the "East-Bay Day" of the Institute's convention. Some 300 delegates and their wives visited the East-Bay Regional Parks and the Oakland City Parks, terminating the day with a barbecue and program in Woodminister Bowl.

ARI INOUE exhibited at the San Mateo Fiesta Flower Show winning first prize in the Oriental Garden Class. Use of natural rock in a naturalistic setting, and the possibilities of using rock and plant materials together for desired effects was emphasized. He is writing an article on the subject which he contemplates publishing soon.

WM. B. SEABURY has moved his offices to 2063 Mountain Blvd., Oakland. He is designing a park for the town of Elkton, Maryland.

OSMUNDSEN, STALEY and GIBSON are working on an Apartment House Subdivision in East Oakland being built by Groom & Groom. Miller and Warneke are the Architects and Osmundsen,

Staley and Gibson are working through them. The firm, in collaboration with the Franciscan Forge, won first prize in their class at the recent San Mateo Fiesta Flower Show.

#### LANDSCAPE ARCHITECT

Geraldine Knight Scott, Landscape Architect, designed one of the prize winning exhibits at the recent San Mateo County Fiesta. Senior partner of the firm of Scott and Imlay, Landscape Architects, she is now preparing plans for gardens in a number of Peninsula communities.



GERALDINE KNIGHT SCOTT  
Landscape Architect

This month the firm opened new offices in Palo Alto, in an old carriage house that Mrs. Scott has extensively remodeled into a studio and residence. Scott and Imlay formerly were located in San Jose.

Mrs. Scott is a newly elected member of the board of directors of the Association of Landscape Architects, San Francisco Bay Region. In addition to participating in the San Mateo County Fiesta, she recently served as a judge of landscape exhibits at the California State Fair and also designed an exhibit for the Marin Art & Garden Show displaying sculpture of Joseph Goethe, Monterey artist.

Kathryn Imlay, associated with Mrs. Scott, is also a member of the Association of Landscape Architects.

#### LANDSCAPE ARCHITECTURE U. C. ACTIVITIES

This fall the Division of Landscape Design has a total enrollment of over eighty students, a marked increase over normal due to reorganization of classroom and drafting space.

Several changes have been made in class procedure, criticism, and lectures to accommodate the larger number of students, and still maintain the individual professor-student contact.

A. M. Soudry, Student President of the U. C. Landscape Design Club, has urged all upper division students to apply for student membership in the Association of Landscape Architects. The new blood will supplement the already active membership, and aid the students to become cognizant of the contemporary problems of Landscape Architecture.

During the summer, students traveled to the four

## FORDERER CORNICE WORKS

Manufacturers of

Hollow Metal Products • Interior Metal Trim  
Elevator Fronts and Cabs  
Metal Plaster Accessories • Sanitary Metal Base  
Flat and Roll Metal Screens  
Metal Cabinets • Commercial Refrigerators

269 POTRERO AVE.

SAN FRANCISCO, CALIF.

HEMLOCK 4100

## STRUCTURAL STEEL

For Class A Buildings,  
Bridges, etc.

**JUDSON PACIFIC - MURPHY CORP.**

4300 EASTSHORE HIGHWAY

EMERYVILLE, CALIF.

## VALUABLE NEWS SERVICE

- BUILDING MATERIAL DEALERS
- CONTRACTORS
- ENGINEERS
- FINANCIAL INSTITUTIONS

**ARCHITECTS REPORTS** gives advance news on construction projects in Northern California, lists: name of projects, location, architect, proposed cost and other pertinent information.

**HANDY** individual slip-reports, issued daily at a total cost of only

\$10 a month

## ARCHITECT'S REPORTS

Published Daily

The ARCHITECT and ENGINEER, Inc.

68 Post Street, San Francisco - DO 8311

## JAMES W. FOLLIN

(From Page 34)

### What About Uncle Sam?

The question is often asked: Is the Federal Government in on this? Is Federal aid necessary? The answer to question number one is "no", so far as direct financing is concerned. To number two: the experts, who have looked over the job in many cities, say Federal aid or at least Federal credit of some kind will be needed.

The biggest figure I have heard about to do the housing part of the urban redevelopment job, not including necessary public works, is a prewar figure of fifty billion dollars. These global figures don't impress me much. At the same time, frankly my hunch is that Uncle Sam will be on the urban redevelopment team sometime, in some way not fully spelled out.

There have been Federal bills with urban redevelopment features in them brought before Congress for several years now. The Wagner-Ellender-Taft bill which became the Taft-Ellender-Wagner bill during the first session of the 80th Congress, while not the earliest, is probably the best known. The T. E. W. bill called for half a billion dollars to help cities get started. Urban redevelopment is in a housing setting in that bill.

Representative Dirksen's bill, H. R. 4012, introduced last session, proposed to authorize the Federal Works Agency to grant or lend half the proceeds from Federal war housing sales to State and local bodies for slum clearance and redevelopment.

None of these bills has cleared Congressional hurdles. It is hard to guess whether an urban redevelopment will be enacted into law when Congress reconvenes. There would seem to be a high probability, however, that the Federal Government will ultimately, perhaps soon, assume a role of collaboration and probably not much more than that, with the cities in this field. Grants and credit formulas have been proposed but nothing has been decided.

### Can Cities Go-It-Alone?

Meanwhile, there is increasing action on the local front although it is still fairly limited in quantity.

Two cities, Indianapolis and Detroit, have attracted national attention, by their go-it-alone attempts to get redevelopment started.

Indianapolis has raised \$1,200,000 in two years with a tax of 10 cents per \$100 of assessed value applied to the whole city. The first area to be done over is being tackled. The cities are watching this courageous venture. It is bound to teach us something, although land values are lower in this metropolitan city than nearly everywhere else. That, of course, makes a very difficult job to some extent easier.

(See Page 43)

ARCHITECT AND ENGINEER

# ESTIMATOR'S GUIDE

## BUILDING AND CONSTRUCTION MATERIALS

PRICES GIVEN ARE FIGURING PRICES AND ARE MADE UP FROM AVERAGE QUOTATIONS FURNISHED BY MATERIAL HOUSES TO SAN FRANCISCO CONTRACTORS. 2 1/2% SALES TAX ON ALL MATERIALS BUT NOT LABOR

All prices and wages quoted are for San Francisco and the Bay District. There may be slight fluctuation of prices in the interior and southern part of the state. Freight cartage, at least, must be added in figuring country work.

**BONDS**—Performance—\$10 per \$1000 of contract. Labor and materials, \$10 per \$1000 of contract.

**BRICKWORK**—

Common Brick—Per 1M laid—\$80.00 to \$100.00 (according to class of work).

Face Brick—Per 1M laid—\$150 to \$200 (according to class of work).

Brick Steps—\$2.30 per lin. ft.

Brick Veneer on Frame Bldg.—Approx. \$1.50 per sq. ft.

Common Brick—\$26.00 per M, truckload lots, f.o.b. job.

Face Brick—\$60 to \$100 per M, truckload lots, delivered.

Cartage—Approx. \$5.00 per M.

**BUILDING PAPER**—

1 ply per 1000 ft. roll.....	\$5.30
2 ply per 1000 ft. roll.....	7.80
3 ply per 1000 ft. roll.....	9.70
Brownskin, Standard, 500 ft. roll.....	7.00

**BUILDING HARDWARE**—

Sash cord com. No. 7.....	\$2.65 per 100 ft.
Sash cord com. No. 8.....	3.00 per 100 ft.
Sash cord spot No. 7.....	3.65 per 100 ft.
Sash cord spot No. 8.....	4.00 per 100 ft.
Sash weights, cast iron, \$75.00 ton.	
Nails, \$3.42 base.	

**CONCRETE AGGREGATES**—

The following prices net to Contractors unless otherwise shown. Carload lots only.

	Bunker per ton	Del'd per ton
Gravel, all sizes .....	\$2.44	\$2.75
Top Sand .....	2.38	3.13
Concrete Mix .....	2.38	3.06
Crushed Rock, 1/4" to 3/4".....	2.38	2.94

	Bunker per ton	Del'd per ton
Crushed Rock, 3/4" to 1 1/2".....	\$2.38	\$3.13
Roofing Gravel .....	2.81	3.50
River Sand .....	2.50	3.06

**Sand**—

Lapis (Nos. 2 & 4).....	3.56	3.94
Olympia (Nos. 1 & 2).....	3.56	3.88

**Cement**—

Common (all brands, paper sacks), carload lots, \$3.02 per bbl. f.o.b. car; delivered \$3.40. Cash discount on carload lots, 10c a bbl., 10th Prox., less than carload lots \$4.00 per bbl. f.o.b. warehouse or delivered. Cash discount 2% on L.C.L.

Trinity White	1 to 100 sacks, \$3.13 sack warehouse or del.; \$9.56 bbl. carload lots.
Medusa White	

**DAMP-PROOFING and Waterproofing**—

Two-coat work, \$5.00 per square. Membrane waterproofing—4 layers of saturated felt, \$9.00 per square. Hot coating work, \$3.00 per square. Medusa Waterproofing, \$3.50 per lb. San Francisco Warehouse. Tricocel waterproofing. (See representative.)

**ELECTRIC WIRING**—\$15 to \$20 per outlet for conduit work (including switches).

Knob and tube average \$6.00 per outlet. (Available only for priority work.)

**ELEVATORS**—

Prices vary according to capacity, speed and type. Consult elevator companies. Average cost of installing a slow speed automatic passenger elevator in small four story apartment building, including entrance doors, about \$8000.00.

**EXCAVATION**—

Sand, \$1.00; clay or shale, \$1.50 per yard. Trucks, \$30 to \$45 per day.

Above figures are an average without water. Steam shovel work in large quantities, less; hard material, such as rock, will run considerably more.

**FIRE ESCAPES**—

Ten-foot galvanized iron balcony, with stairs, \$250 installed on new buildings; \$300 on old buildings.

**FLOORS**—

Composition Floors, such as Magnesite, 50c per square foot.

Linoflor—2 gages—\$3.00 per sq. yd.

Mastipave—\$1.50 per sq. yd.

Battleship Linoleum—available to Army and Navy only—1/8"—\$3.50 sq. yd. 3/16"—\$3.50 sq. yd.

Terazzo Floors—\$1.50 per sq. ft.

Terazzo Steps—\$2.50 per lin. ft.

Mastic Wear Coat—according to type—20c to 35c.

**Hardwood Flooring**—

Standard Mill grades not available.

Victory Oak—T & G

3/4" x 2 1/4".....	\$252.00 per M. plus Cartage
1/2" x 2".....	\$210.00
1/2" x 1 1/2".....	200.00

Prefinished Standard & Better Oak Flooring  
3/4" x 3 1/4".....\$265.00 per M. plus Cartage  
1/2" x 2 1/2"..... 237.00 per M. plus Cartage

**Maple Flooring**

3/4" T & G Clear	\$330.00 per M. plus Ctg.
2nd	305.00 per M. plus Ctg.
3rd	255.00 per M. plus Ctg.

Floor Layers' Wage, \$12 1/2 per hr. (Legal as of July 1, 1947. Given us by Inlaid Floor Co.)

**GLASS**—

Single Strength Window Glass.....	\$.40 per □ ft.
Double Strength Window Glass.....	.60 per □ ft.
Plate Glass, under 75 sq. ft.....	1.25 per □ ft.
Polished Wire Plate Glass.....	2.10 per □ ft.
Rgh. Wire Glass .....	.60 per □ ft.
Obscure Glass .....	.40 per □ ft.
Glazing of above is additional.	
Glass Blocks.....	\$2.75 per □ ft. set in place

**HEATING**—

Average, \$2.50 to \$3.00 per sq. ft. of radiation, according to conditions.

Warm air (gravity) average \$64 per register.

Forced air average \$91 per register.

## INSULATION AND WALLBOARD—

Rubber—Insulation—	
(2")	\$65.00 per M sq. ft.
Cotton—Insulation—Full-thickness	
(3½")	\$95.50 per M sq. ft.
Aluminum—Insulation—Foil-mounted	
on both sides	\$33.50 per M sq. ft.
Tileboard—4'x6' panel	\$9.00 per panel
Wallboard—½" thickness	\$49.50 per M sq. ft.
Finished Plank	\$69.00 per M sq. ft.
Ceiling Tileboard	\$69.00 per M sq. ft.

IRON—Cost of ornamental iron, cast iron, etc., depends on designs.

## LUMBER—

No. 1 Common	\$90.00 per M
No. 2 Common	88.00 per M
Select O. P. Common	94.00 per M

### Flooring—

Per M Delvd.

V.G.-D.F. B & Btr. 1 x 4 T & G Flooring	\$170.00
"C" and better—all	170.00
"D" and better—all	170.00

Rwd. Rustic—"A" grade, medium dry	150.00
8 to 24 ft.	
"B" grade, medium dry	150.00

### Plywood

	15c to 18c per ft.
Plycord	9½c per ft.
Plywall	9c per ft.
Plyform	15c per ft.

### Shingles (Rwd. not available)—

Red Cedar No. 1—	\$13.00 per square; No. 2, \$10.50; No. 3, \$9.00.
Average cost to lay shingles,	\$6.00 per square.
Cedar Shakes—Tapered: ½" to ¾" x 25"—	\$17.00 per square.
Resawn: ¾" to 1¼" x 25"—	\$22.00 per square
Average cost to lay shakes,—	8.00 per square

## MILLWORK—Standard.

D. F. \$150 per 1000. R. W. Rustic \$175 per 1000 (delivered).
Double hung box window frames, average with trim, \$12.50 and up, each.
Complete door unit, \$15 to \$25.
Screen doors, \$6.00 to \$8.00 each.
Patent screen windows, \$1.25 a sq. ft.
Cases for kitchen pantries seven ft. high, per lineal ft., \$12.00 each.
Dining room cases, \$15.00 per lineal foot. Rough and finish about \$1.00 per sq. ft.
Labor—Rough carpentry, warehouse heavy framing (average), \$60.00 per M.
For smaller work average, \$60.00 to \$75.00 per 1000.

## MARBLE—(See Dealers)

## PAINTING—

Two-coat work	per yard 60c
Three-coat work	per yard 80c
Cold water painting	per yard 25c
Whitewashing	per yard 15c
Turpentine	\$1.85 per gal. in 5-gal. cont.
Raw Linseed Oil	\$3.33 per gal. in 5-gal. cont.

Boiled Linseed Oil	\$3.23 per gal. in drums.
Boiled Linseed Oil—	\$3.33 per gal. in 5-gal. containers.
Replacement Oil—	\$2.75 per gal. in drums, \$2.75 per gal. in 5-gal. containers.
Use Replacement Oil	\$3.00 per gal. in 1 gal. cont.
A deposit of \$7.50 required on all drums.	

## PATENT CHIMNEYS—

6-inch	\$2.00 lineal foot
8-inch	2.50 lineal foot
10-inch	3.50 lineal foot
12-inch	4.50 lineal foot

## PLASTER—

Neat wall, per ton delivered in S. F. in paper bags, \$17.60.

## PLASTERING (Interior)—

3 Coats, metal lath and plaster	Yard \$3.00
Keene cement on metal lath	3.50
Ceilings with ¾ hot roll channels metal lath (lathed only)	3.00
Seilings with ¾ hot roll channels metal lath plastered	4.50
Single partition ¾ channel lath 1 side (lath only)	3.00
Single partition ¾ channel lath 2 inches thick plastered	8.00
4-inch double partition ¾ channel lath 2 sides (lath only)	5.75
4-inch double partition ¾ channel lath 2 sides plastered	8.75
Thermax single partition; 1" channels; 2¼" overall partition width. Plastered both sides	7.50
Thermax double partition; 1" channels; 4¼" overall partition width. Plastered both sides	11.00
3 Coats over 1" Thermax nailed to one side wood studs or joists	4.50
3 Coats over 1" Thermax suspended to one side wood studs with spring sound isolation clip	5.00
Note—Channel lath controlled by limitation orders.	

## PLASTERING (Exterior)—

2 coats cement finish, brick or concrete wall	Yard \$2.50
3 coats cement finish, No. 18 gauge wire mesh	3.50
Lime—	\$4.00 per bbl. at yard.
Processed LLime—	\$4.15 per bbl. at yard.
Rock or Grip Lath—	¾"—30c per sq. yd.
¼"—29c per sq. yd.	
Composition Stucco—	\$4.00 sq. yard (applied).

## PLUMBING—

From \$150.00 per fixture up, according to grade, quality and runs.

## ROOFING—

"Standard" tar and gravel, 4 ply—	\$11.00 per sq. for 30 sqs. or over.
Less than 30 sqs.	\$14.00 per sq.
Tile	\$40.00 to \$50.00 per square.
Redwood Shingles, \$15.00 per square in place.	
5/2 #1-16" Cedar Shingles, 4½" Exposure	\$16.50 square

5/8 x 16"—#1 Cedar Shingles, 5" Exposure	\$17.00 square
4/2 #1-24" Royal Shingles, 7½" Exposure	\$18.25 square
Re-coat with Gravel	\$5.50 per sq.
Asbestos Shingles	\$30 to \$60 per sq. laid.
1/2 x 25" Resawn Cedar Shakes, 10" Exposure	\$18.50
3/4 x 25" Resawn Cedar Shakes, 10" Exposure	21.00
1 x 25" Resawn Cedar Shakes, 10" Exposure	22.00
Above prices are for shakes in place.	

## SHEET METAL—

Windows—Metal, \$2.50 a sq. ft.  
Fire doors (average), including hardware \$2.80 per sq. ft.

## SKYLIGHTS—(not glazed)

Copper, \$1.25 sq. ft. (flat).  
Galvanized iron, 65c sq. ft. (flat).  
Vented hip skylights 90c sq. ft.

## STEEL—STRUCTURAL—

\$220 per ton erected, when out of mill.  
\$270 per ton erected, when out of stock.

## STEEL REINFORCING—

\$150 to \$170 per ton, in place.

## STORE FRONTS (None available).

## TILE—

Ceramic Tile Floors—	\$1.50 per sq. ft.
Cove Base—	\$1.25 per lin. ft.
Glazed Tile Wainscot—	\$1.50 per sq. ft.
Asphalt Tile Floor 1/8" x 3/8"—	\$.40 per sq. ft.
Light shades slightly higher.	
Cork Tile—	\$1.00 per sq. ft.
Mosaic Floors—	See dealers.
Lino-Tile—	\$1.00 per sq. ft.

### Wall Tile—

Glazed Terra Cotta Wall Units (single faced) laid in place—approximate prices:	
2 x 6 x 12	\$1.25 sq. ft.
4 x 6 x 12	1.50 sq. ft.
2 x 8 x 16	1.45 sq. ft.
4 x 8 x 16	1.75 sq. ft.

## VENETIAN BLINDS—

75c per square foot and up. Installation extra.

## WINDOWS—STEEL—

50c per square foot, \$5 for ventilators.



# JAMES W. FOLLIN

(From Page 40)

Detroit is also enterprising. With the city and the private construction industry cooperating the Motors Capital is taking an initial loss on land acquisition and preparation and has computed it will later recover that loss through increased tax revenues from the redeveloped sites. The details of the Detroit and Indianapolis plans are available and both cities recognize an obligation to report fully to other communities facing similar tasks.

## Federal Works and Urban Redevelopment

Federal Works Agency is already in one sense, and a real one, in the urban redevelopment business. As the chief construction arm of the civil establishment it has worked with the cities of the country, the small towns and rural communities as well as metropolitan centers. The home towns of every one of you is served by our organization. I should say your organization, because FWA is only nominally in Washington—the services it performs are local.

The Public Roads Administration has for years been closely associated with the highway commissions of State government and their staffs. PRA

helped the States build their modern highway systems between cities. Recently Congress has authorized an extension of this function and at present, again in partnership with the State governments, there is beginning a new chapter: City-State-Federal teamwork on highway building. The new express highways, advanced in engineering and in traffic efficiency are gradually appearing—and their number will steadily grow. These will be the boundary insulators and traffic expeditors serving many urban redevelopment areas of the future. Meanwhile they will provide a major source of relief to the traffic problem which exists in every city. More than any single element highways are the backbone of an urban community and the underlying basic consideration in the overall city or metropolitan plan.

Public Buildings Administration, another member of the Federal Works team, is the Nation's largest manager of Federal property in urban areas. Federal offices, Federal court buildings, the post offices are constructed and maintained by PBA in the localities and much in addition. PBA is associated with many cities on their civic cen-

(See Page 44)

## BUILDING TRADES WAGE (JOB SITES) NORTHERN AND CENTRAL CALIFORNIA

ATTENTION: The following are the PREVAILING hourly rates of compensation as determined by the Wage Adjustment Board, or which have been determined by the United States Department of Labor—Revised to Nov. 1, 1947. Wage scales shown are those being paid and in effect mostly by agreement between employees and their union.

CRAFT	San Francisco	Alameda and Contra Costa	Marin	Vallejo	San Mateo	San Jose	Stockton	Sacramento	Fresno
ASBESTOS WORKERS	1.90	1.75	1.75	1.75	1.75	1.75	1.75	1.75	1.75
BRICKLAYERS	2.25	2.05	2.05	2.05	2.05	2.05	1.75	2.05	2.00
BRICKLAYERS, HODCARRIERS	1.75	1.57½	1.57½	1.57½	1.57½	1.57½	1.47½	1.15	1.25
CARPENTERS	2.00	1.75	1.75	1.75	1.75	1.62½	1.50	1.50	1.50
CEMENT FINISHERS	2.02½	1.75	1.75	1.75	1.75	1.75	1.75	1.75	1.75
ELECTRICIANS	2.25	1.87½	1.87½	1.70	1.87½	1.87½	1.75	1.82½	1.75
ENGINEERS: MATERIAL HOIST	2.25	1.60	1.60	1.60	1.60	1.60	1.60	1.60	1.60
PILE DRIVER	2.25	2.00	2.00	2.00	2.00	2.00	2.00	2.00	2.00
STRUCTURAL STEEL	2.00	2.00	2.00	2.00	2.00	2.00	2.00	2.00	2.00
GLASS WORKERS	1.58½	1.58½	1.58½	1.58½	1.58½	1.21	1.40	1.37½	1.37½
IRONWORKERS: ORNAMENTAL	1.85	1.85	1.85	1.85	1.85	1.85	1.85	1.85	1.85
REINF. RODMEN	2.00	1.75	1.75	1.75	1.75	1.75	1.75	1.75	1.75
STRUCTURAL	2.00	2.00	2.00	2.00	2.00	2.00	2.00	2.00	2.00
LABORERS: BUILDING & CONCRETE	1.40	1.25	1.15	1.15	1.15	1.15	1.25	1.25	1.15
LATHERS	2.25	1.90	1.60	1.87½	1.75	2.00	1.87½	1.60	1.87½
MARBLE SETTERS	2.00	1.75	1.75	1.75	1.75	1.75	1.75	1.75	1.75
MOSAIC & TERRAZZO	2.15	1.75	1.75	1.75	1.75	1.75	1.60	1.60	1.12½
PAINTERS	2.00	1.75	1.75	1.64	1.75	1.75	1.60	1.60	1.50
PILEDRIVERS	2.02½	1.86	1.86	1.86	1.86	1.86	1.86	1.86	1.86
PLASTERERS	2.25	2.03	1.75	2.00	2.05	2.00	2.00	1.87½	1.87½
PLASTERERS' HODCARRIERS	2.00	1.75	1.75	1.75	1.75	1.75	1.65	1.65	1.40
PLUMBERS	2.25	1.87½	1.87½	1.87½	1.87½	1.87½	1.87½	1.87½	1.87½
ROOFERS	2.00	1.62½	1.50	1.62½	1.25	1.37½	1.50	1.50	1.50
SHEET METAL WORKERS	2.00	1.75	1.75	1.75	1.75	1.75	1.75	1.75	1.75
SPRINKLER FITTERS	1.75	1.58	1.58	1.58	1.58	1.58	1.58	1.58	1.58
STEAMFITTERS	2.25	1.87½	1.87½	1.87½	1.87½	1.87½	1.87½	1.87½	1.87½
STONESETTERS (MASONS)	2.37½	2.05	2.05	2.05	2.05	2.05	1.75	2.05	2.00
TILESETTERS	2.15	1.75	1.75	1.75	1.75	1.75	1.37½	1.37½	1.37½

Prepared and compiled by

CENTRAL CALIFORNIA CHAPTER, ASSOCIATED GENERAL CONTRACTORS OF AMERICA

with the assistance and cooperation of secretaries of General Contractors Associations and Builders Exchanges of Northern California

# CLASSIFIED ADVERTISING

RATE: 10c PER WORD . . . CASH WITH ORDER

MINIMUM \$2.50

**ARCHITECT'S REPORTS**—A valuable advance news service giving building and construction information daily on projects in Northern California. Name, location, architect, proposed cost, etc., on individual slips. Ideal for securing new business leads. Hundreds of items, total monthly cost only \$10. Don't delay, subscribe today. ARCHITECT & ENGINEER, Room 618, 68 Post Street, San Francisco, California. Phone DOuglas 2-8311.

**PHOTOGRAPHS:** Specializing in building and construction photographs for publication, or historic records. For Industrial-Aerial-Publicity photography use the INDUSTRIAL PHOTO'S, Room 722, Hearst Bldg., San Francisco, Phone SUtter 1-6953.

**METAL WINDOWS** (Steel-Aluminum-Bronze). Large Stock, ALL TYPES. STEEL SASH SALES & SERVICE, Weehawken, N. J.

**ENGRAVING**—Good engravings are essential to a satisfactory job of printing reproduction. For the best, see Poor Richard Photo Engraving Co., 324 Commercial St., San Francisco.

# HOGAN LUMBER CO.

Wholesale and Retail

## LUMBER

MILL WORK • SASH & DOORS

Office, Mill, Yard and Docks  
SECOND AND ALICE STREETS • OAKLAND, CALIF.

Telephone GLencourt 1-6861

# SISALKRAFT

REG. U. S. PAT. OFF.

*"More than a building paper"*

## THE SISALKRAFT CO.

205 West Wacker Drive  
Chicago, Ill.

55 New Montgomery Street  
San Francisco, Calif.

# CLINTON CONSTRUCTION CO. OF CALIFORNIA

## General Contractors

923 FOLSOM STREET • SAN FRANCISCO

SUtter 1-3440

# SANTA MARIA INN

## SANTA MARIA, CALIFORNIA

FRANK J. McCOY, General Manager

FERNAND E. PIMENTEL, Manager

On the  
Coast  
Highway  
between  
San  
Francisco  
and  
Los  
Angeles



American  
or  
European  
Plan  
•  
Old  
English  
Tap  
Room

# JAMES W. FOLLIN

(From Page 43) \*

ter plans; it will, in the nature of its responsibilities be an active partner with the local people and their officials in urban redevelopment.

The Bureau of Community Facilities is well known to this group, perhaps chiefly as a result of its Advance Planning Program, but in addition because it administered war community facilities and services under the Lanham Act. BCF has advanced interest-free funds to cities, counties and States to prepare plans and specifications of needed and useful projects—water supply and sewers, schools, city halls, hospitals and the like. Congress adjourned without replenishing the Bureau's funds, but we are hopeful this will be remedied when Congress reconvenes. Where city planning has been done locally, BCF has required projects aided in its program to conform to the community's overall plan.

From this "capsule" description of the Federal Works Agency's far flung operations, I believe it will be clear that this Federal agency has had and will continue to have an interest and acknowledges a responsibility in urban communities.

There is increasing teamwork in the Federal Works Agency itself in the cities and States of the country where our local offices are, as well as in Washington. In our offices around the United States joint committees of the three main branches of FWA are operating to coordinate our work in the cities and regions.

As for metropolitan planning and urban redevelopment, our long experience in helping local people tussle with their local problems, and our stores of information on local conditions calling for remedy, are available. Let me say in conclusion: we are ready to work with you; or your local and metropolitan planning. We are ready and waiting to undertake whatever part Congress decides the Federal Government will play henceforth in urban redevelopment. Count us in on the team!

## LANDSCAPE ARCHITECTURE

(From Page 39)

winds. Wallace Ruff, Bill Rosenburg, Danny Hawk and Jesse Johnson jeeped to Baja California for three weeks of camping and "fishing"; Robert Cornwall studied at the University of Mexico; and Bill Gant has stories about the fish on his trip along the Alcan Highway to Alaska; Jim Cowan spent the summer in Hawaii.

The Division of Landscape Design now comprises Leland Vaughn, Chairman; Harry W. Shepherd, Professor; Robert Royston, Assistant Professor; Wallace Ruff, Teaching Assistant; and Marion F. Page, Secretary.

## A PLANNED COMMERCIAL CENTER

(From Page 11)

and Rodeo. Other shops in the commercial area will be built later.

The present recreation buildings will be remodeled to serve the future community with a restaurant and a dining terrace overlooking Carquinez Heights and the Bay.

To meet the demand for adequate housing, the seven apartment houses will be erected first at the south end of the development, with a landscape treatment comparable to that of the open park. The development will include a playground, tennis courts, and a swimming pool.

This type of development has a distinct advantage in being designed and laid out by one form of planners. The design of the integral parts—housing, shopping, and recreational facilities—through coordination of planners, architects and landscape architects, presents a unified solution to the problem.

The Solano County Planning Commission recently approved the commercial zoning of the property and the project will be started early in 1948.

## BOOK REVIEWS PAMPHLETS AND CATALOGUES

### DUST & FUME ELIMINATORS, Schmiegl Industries Inc., 300 Piquette Ave., Detroit 2, Michigan.

A 12-page brochure containing illustrations, designs, and plans of the SCHMIEGL "Centri-Merge," swirl type dust and fume eliminators. Also description of uses.

### Q-FLOOR WIRING Data Manual. General Electric Co., Bridgeport 2, Conn.

A 106 page data manual describing G-E Q-FLOOR WIRING is now available to Architects and Engineers (A.I.A. File No. 31-C-62). Contains general description of Q-Floors, fittings, accessories, etc., necessary to utilize the cells of the floor as raceways for electrical conductors.

Forty-pages of dimensional drawings and 21 pages of photographs. Copy available by writing G-E, Bridgeport 2, Conn.

**"AMERICAN - MARSH"**  
CONDENSATION UNIT

Pumping Machinery for Every Purpose

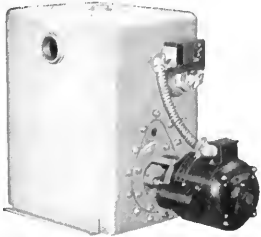

For Service Call DOuglas 2-6794 or MUtual 8322

**SIMONDS MACHINERY CO.**  
SAN FRANCISCO 816 FOLSOM      LOS ANGELES 455 EAST 4TH

**VERMONT MARBLE COMPANY**

Producers and Finishers of Domestic and Imported Marbles

525 MARKET STREET, SAN FRANCISCO  
Phone SUtter 1-6747  
3522 COUNCIL STREET  
(Beverly Blvd. at Virgil Ave.)  
LOS ANGELES 4, CALIF.  
Telephone Fairfax 7834



The Most Complete Line of STEELS and BUILDING MATERIALS  
Made by a Single Producer



See Sweet's Catalog File or write us for full information.

**REPUBLIC STEEL CORPORATION**  
GENERAL OFFICES: CLEVELAND, OHIO

DENVER, COLORADO . . . CONTINENTAL OIL BUILDING  
LOS ANGELES, CALIFORNIA . . . EDISON BUILDING  
SALT LAKE CITY, UTAH . . . WALKER BANK BUILDING  
SAN FRANCISCO, CALIFORNIA . . . RIALTO BUILDING  
SEATTLE, WASH. . . . . WHITE-HENRY-STUART BUILDING

**PACIFIC MANUFACTURING CO.**

HIGH CLASS INTERIOR FINISH  
QUALITY MILLWORK

142 SANSOME ST., SAN FRANCISCO  
GARfield 1-7755

6820 MCKINLEY AVE., LOS ANGELES  
THornwall 4196

BUILDERS EXCHANGE, OAKLAND

# NEW!

★ *Venetian Blinds*

**BUILT WITH**

**REMOVABLE SLATS**

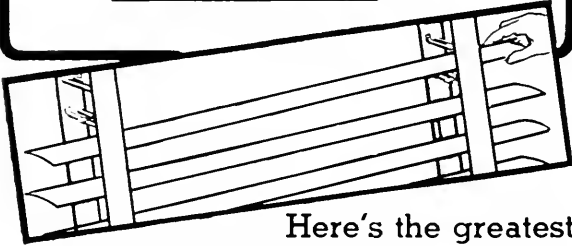

Here's the greatest  
Blind improvement of 50 years  
**AMBASSADOR VENETIANS with**  
**REMOVABLE SLATS**

Just unsnap the fasteners (there's only one to each slat) and slip the slats out. Clean them . . . it's as easy as washing dishes, then put them back. It couldn't be simpler. • These revolutionary Ambassador Venetians are ideal for use in all

**Offices**  
**Apartments**  
**Hotels, Hospitals**  
**Public Buildings**  
**Factories**

May we show you how much better they are, how much tighter they close, and how little they cost?

**GUNN, CARLE & Co.**

20 POTRERO AVE. • SAN FRANCISCO 3

UNderhill 1-5480

## SIMPLIFIED PLUMBING FIXTURE

A voluntary Simplified Practice Recommendation for Plumbing Fixture Fittings and Trim for Housing has been approved for general use by the Commodity Standards Division of the National Bureau of Standards.

## FITTINGS AND TRIM

The recommendation is identified as R227-47.

It covers the necessary fitting and trim for plumbing fixtures in single and multiple dwellings. Copies are available from the Government Printing Office, Washington, D. C.

## SCHOOL BONDS VOTED

Albany, California, recently voted \$65,000 in bonds for construction of a 5-classroom Primary School Building. Wm. H. Young, Architect.

## THEATRE REMODEL

Salih Bros, General Contractors of San Francisco, have been awarded a contract for rebuilding the old American Theatre in Chico, California at an estimated cost of \$150,000.

NEW GRAMMAR SCHOOL. Bonds have been voted for a new \$35,000 school at Soda Springs, Placer County, California. Koblick & Fisher, Architects, Sacramento.

RANCH HOUSE. Architect Guy L. Rosebrook of San Leandro is awarding contracts on the construction of the \$200,000 Ranch House near Yuba City, California. The structure will include 20 rooms, 5 baths, a 125 foot swimming pool and a recreation building.

MacDONALD, YOUNG & NELSON, Contractors have been awarded contract for construction of a \$500,000 department store building in Modesto, California.

NEW HOTEL near Williams, Arizona, to be known as the "Bill Williams Hotel" will cost \$2,500,000. Millard Sheets is in charge of designs.

# TILE

**UNUSUAL AND PRACTICAL  
INSTALLATIONS OF  
CERAMIC AND FAIENCE TILE**

for bathrooms, kitchens, vestibules, stores,  
patios and cocktail bars

  
**FOX TILE CO.**

3247 E. 14TH STREET, OAKLAND  
Phone: ANdover 1-0431

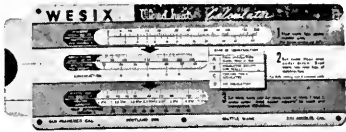

**WESIX** *Wiredheat* **CALCULATOR**  
 "Slide-rule" style, for quick computing of the correct WESIX Wiredheat SYSTEM for any house. Available to architects, engineers, contractors and dealers.

**WESIX ELECTRIC HEATER CO.**  
 390 First Street, San Francisco

## MULLEN MFG. COMPANY

BANK, STORE AND OFFICE  
 FIXTURES—CABINET WORK  
 OF GUARANTEED QUALITY  
 CHURCH SEATING

Office and Factory  
 60-80 RAUSCH ST., Bet. 7th and 8th Sts.  
 San Francisco  
 Telephone UNderhill 1-5815

## THE TORMEY COMPANY

GENERAL PAINTERS  
 AND DECORATORS

Phone UNderhill 1-1913

563 FULTON STREET  
 San Francisco

*Fine*  
**ENGRAVINGS**

**POOR RICHARD**  
 PHOTO ENGRAVING CO.  
 220-224 COMMERCIAL STREET  
 SAN FRANCISCO, CALIF.

STATEMENT OF THE OWNERSHIP, MANAGEMENT, CIRCULATION, ETC., REQUIRED BY THE ACT OF CONGRESS OF AUGUST 24, 1912, AS AMENDED BY THE ACTS OF MARCH 3, 1933, AND JULY 2, 1946.

Of the Architect and Engineer, published monthly at San Francisco, Calif., for October 1, 1947.

State of California )  
 City and County of San Francisco ) SS.

Before me, a notary public in and for the state and county aforesaid, personally appeared L. B. Penhorwood, who, having been duly sworn according to law, deposes and says that she is the Business Manager of The Architect and Engineer, and that the following is to the best of her knowledge and belief, a true statement of the ownership, management (if daily paper, the circulation), etc., of the aforesaid publication for the date shown in the above caption, required by the Act of August 24, 1912, as amended by the Acts of March 3, 1933, and July 2, 1946, (section 537, Postal Laws and Regulations), printed on the reverse of this form, to wit:

1. That the names and addresses of the publisher, editor, managing editor, and business managers are:

Publisher, The Architect and Engineer, Inc., 68 Post St., San Francisco, Calif.

Editor: Edwin H. Wilder, 68 Post St., San Francisco, Calif.

Managing Editor—None.

Business Manager, L. B. Penhorwood, 68 Post St., San Francisco, Calif.

2. That the owner is: (If owned by a corporation, its name and address must be stated and also immediately thereunder the names and addresses of stockholders owning or holding one per cent or more of total amount of stock. If not owned by a corporation, the names and addresses of the individual owners must be given. If owned by a firm, company, or other unincorporated concern, its name and address, as well as those of each individual member, must be given.)

The Architect and Engineer, Inc., 68 Post St., San Francisco, Calif.

K. P. Kierulff, 68 Post St., San Francisco, Calif.

E. N. Kierulff, 68 Post St., San Francisco, Calif.

L. B. Penhorwood, 68 Post St., San Francisco, Calif.

F. W. Jones, 1153 McKinley Ave., Oakland, Calif.

V. S. Yallop, 68 Post St., San Francisco, Calif.

E. J. Cardinal, 942 Howard St., San Francisco, Calif.

Sewall Smith, Lafayette, Calif.

3. That the known bondholders, mortgagees, and other security holders owning or holding one per cent or more of total amount of bonds, mortgages, or other securities are: (If there are none, so state.)

None.

4. That the two paragraphs next above, giving the names of the owners, stockholders, and security holders, if any, contain not only the list of stockholders and security holders as they appear upon the books of the company but also, in cases where the stockholder or security holder appears upon the books of the company as trustee or in any other fiduciary relation, the name of the person or corporation, for whom such trustee is acting, is given; also that the said two paragraphs contain statements embracing affiant's full knowledge and belief as to the circumstances and conditions under which stockholders and security holders who do not appear upon the books of the company as trustees, hold stock and securities in a capacity other than of a bona fide owner; and this affiant has no reason to believe that any other person, association, or corporation has any interest direct or indirect in the said stock, bonds, or other securities than as so stated by him.

5. That the average number of copies of each issue of this publication sold or distributed, through the mails or otherwise, to paid subscribers during the twelve months preceding the date shown above is: (This information is required from daily publications only.)

L. B. Penhorwood, Business Mgr.

Sworn to and subscribed before me this 30th day of September, 1947.

(Seal) CHAS. F. DUSENBERG  
 Notary Public in and for the City and County of San Francisco, Calif.

(My commission expires May 23, 1949.)

## Scott Company

HEATING - - PLUMBING - - TILE



243 MINNA STREET

SAN FRANCISCO

Phone EXbrook 2-6741

## DINWIDDIE CONSTRUCTION COMPANY

BUILDERS

CROCKER BUILDING

SAN FRANCISCO



**HERRICK  
 IRON WORKS**  
 STRUCTURAL STEEL  
 REINFORCING STEEL

18TH AND CAMPBELL STS.  
 OAKLAND, CALIF.  
 Phone GLencourt 1-1767

Phone GARfield 1-1164

## Thomas B. Hunter

DESIGNER OF HEATING

AIR CONDITIONING  
 VENTILATING AND WIRING  
 SYSTEMS, MECHANICAL  
 AND ELECTRICAL EQUIP-  
 MENT OF BUILDINGS



41 SUTTER STREET  
 ROOM 710

San Francisco

California

## George F. Brayer

ELECTRICAL  
CONTRACTOR

166 Seventh Street  
San Francisco

Phone: Market 1-1761

## PITTSBURGH TESTING LABORATORY

Successors to  
SMITH, EMERY & COMPANY

*Testing and Inspecting  
Engineers and Chemists*

Structural Materials, Structures  
Equipment, Pipe, Soils.

651 Howard St., San Francisco 5  
EXbrook 2-1747

## A. F. MATTOCK CO.

*Builders*



212 CLARA STREET  
SAN FRANCISCO

## INDEPENDENT IRON WORKS

Steel Buildings  
Service Stations  
Steel Storage Tanks  
Fabricated Plate Work  
Steel & Sheet Metal Products  
Fabricated Structural Steel  
Steel Distributors

Eighth & Pine Sts. Oakland, 7

## Index to Advertisers

ALADDIN Heating Corp. ....	48
ANGIER Pacific Corp. ....	*
ARCHITECTS Reports .....	40
BASALT Rock Company .....	Back Cover
BAXTER & Company, J. H. ....	36
BRAYER, Geo. F. ....	48
CLASSIFIED Advertising .....	43
CLINTON Construction Company ..	44
DETROIT Steel Products Co. ....	7
DINWIDDIE Construction Co. ....	47
FORDERER Cornice Works. ....	40
FOX Tile Co. ....	46
FULLER, W. P. Co. ....	1
GUNN, Carle & Company. ....	46
HANKS, Inc., Abbott A. ....	48
HAWS Drinking Faucet Company. ....	5
HERRICK Iron Works .....	47
HOGAN Lumber Company .....	44
HUNT, Robert W., Company. ....	48
HUNTER, Thos. B. ....	47
INDEPENDENT Iron Works .....	48
JUDSON, Pacific-Murphy Corp. ....	40
KRAFTILE Company .....	34
MATTOCK, A. F. ....	48
MICHEL & Pfeffer Iron Works. ....	Inside Back Cover
MULLEN Mfg. Co. ....	47
MUELLER Brass Co. ....	2
NORTHERN California Electrical Bureau .....	35
PACIFIC Coast Aggregates, Inc. ....	*
PACIFIC Coast Gas Association. ....	*
PACIFIC Manufacturing Company. ....	45
PACIFIC Portland Cement Company .....	Inside Front Cover
PACIFIC Telephone & Telegraph Co. ....	33
PITTSBURGH Testing Laboratory. ....	48
POOR RICHARD Engraving .....	47
REMILLARD-Dandini Co. ....	48
REPUBLIC Steel Corporation .....	45
SANTA Maria Inn .....	44
SCOTT Co. ....	47
SIMONDS Machinery Company .....	45
SIMPSON Logging Co. ....	6
SISALKRAFT Company .....	44
SMOOT-Holman Co. ....	37
STANLEY Works, The. ....	34
TAYLOR Co., Halsey W. ....	*
TORMEY Company, The .....	47
U. S. BONDS. ....	*
VERMONT Marble Company .....	45
WESTERN Asbestos Company. ....	*
WESIX Company .....	47
WOOD, E. K., Lumber Company. ....	36

\*Indicates Alternate Months

## A L A D D I N

### Heating Corp.

Specializing in  
QUALITY HEATING  
EQUIPMENT

2222 San Pablo Avenue  
OAKLAND  
TWinoaks 3-1022

## ABBOT A. HANKS, INC. Engineers & Chemists

INSPECTING — TESTING — CONSULTING  
CONCRETE • STEEL • MATERIALS  
CHEMICAL AND TESTING  
LABORATORIES

• RESEARCH AND INVESTIGATION •

—

TESTS OF STRUCTURAL MATERIALS  
DESIGN OF CONCRETE MIXES  
SHOP AND ERECTION INSPECTION OF  
STRUCTURES AND EQUIPMENT  
INVESTIGATION OF STRUCTURES  
AND MATERIALS  
TESTS AND INVESTIGATION OF  
FOUNDATION SOILS  
FIRE RESISTANCE AND INSULATION  
TESTS

624 Sacramento Street, San Francisco

## Robert W. Hunt Company ENGINEERS

Inspection • Tests • Consultation  
Schools and Other Structures  
Are Built as Designed

*When Construction Materials are  
Inspected at point of Manufacture  
and during Erection by*

**ROBERT W. HUNT COMPANY**

*Cement, Concrete, Chemical, Metallurgical,  
X-Ray and Physical Laboratories*

Chicago - New York - Pittsburgh  
Los Angeles - All Large Cities

San Francisco, 251 Kearny Street

## REMILLARD-DANDINI Co.

Brick and  
Masonry Products



400 MONTGOMERY STREET  
SAN FRANCISCO, CALIF.

# ARCHITECT AND ENGINEER

DECEMBER, 1947



# WHEN DRAFTING



# YOUR PLANS for 1948



## Include A Regular Schedule

of

# ADVERTISING

To reach the Construction Industry of the West . . . .  
Architects, Engineers, Contractors, Planning Commissions

IN

# ARCHITECT & ENGINEER

MAGAZINE

68 Post Street

San Francisco 4, California

Phone EXbrook 2-7182

Publishers of ARCHITECTS (daily) REPORTS



# ARCHITECT

Vol. 171 No. 3

# AND ENGINEER

ARCHITECTS' REPORTS—Published Daily

E. H. WILDER  
Editor

MARK DANIELS, A.I.A.  
Associate Editor

PROF. LELAND VAUGHAN  
Landscape Architecture

MICHAEL GOODMAN  
Planning

JOHN S. BOLLES, A.I.A.  
Book Reviews



## COVER PICTURE:

Significant of the HOLIDAY SEASON the Stained Glass medallion reproduced on the cover this month is a representation of the Nativity, translated in terms of color and light by the CUMMINGS STUDIO of San Francisco. (See Page 4 for further details.)

## Contents for

# DECEMBER

EDITORIAL NOTES . . . . .	4
NEWS AND COMMENT ON ART . . . . .	9
THE GARDEN DESIGNER SETS THE STAGE . . . . .	13
By RUTH JAFFE, A.L.A.	
RESEARCH IN ENGINEERING SEISMOLOGY, A Report . . . . .	16
By G. W. HOUSNER, Prof., California Institute of Technology	
EMERGENCY COMMITTEE PROGRAM FOR COMMUNITY RELIEF, A Report . . . . .	17
By JOHN G. LITTLE, Superintendent, Bureau of Building Inspection, San Francisco	
NEW PLANT CHALLENGE CREAM AND BUTTER ASSOCIATION, Berkeley, California . . . . .	18
ALBEN R. FROBERG, Architect	
A.I.A. ACTIVITIES . . . . .	29
WITH THE ENGINEERS . . . . .	30
HEADLINE NEWS & VIEWS . . . . .	34
By E. H. W.	
IN THE NEWS . . . . .	35, 41, 44
LANDSCAPE ARCHITECTURE, Notes of the Profession . . . . .	36
ESTIMATOR'S GUIDE, Building and Construction Materials . . . . .	39
BUILDING TRADES WAGE SCALES . . . . .	41
Northern and Central California	
CLASSIFIED ADVERTISING . . . . .	41
BOOK REVIEWS, Pamphlets and Catalogues . . . . .	43
INDEX TO ARTICLES AND ILLUSTRATIONS . . . . .	47

Volumes 168-171, 1947

ARCHITECT AND ENGINEER (Established 1905) is published on the 15th of the month by The Architect and Engineer, Inc., 68 Post St., San Francisco 4; Telephone EXbrook 2-7182. President, K. P. Kierulff; Vice-President and Manager, L. B. Penhorwood; Treasurer, E. N. Kierulff.

Los Angeles Office: Wentworth F. Green, 6605 Hollywood Blvd., Los Angeles 28. Telephone HEMPstead 3171.

Entered as second class matter, November 2, 1905, at the Post Office in San Francisco, California, under the Act of March 3, 1879. Subscriptions United States and Pan America, \$3.00 a year; \$5.00 two years; foreign countries \$5.00 a year; single copy 50c. ARCHITECTS' REPORTS are published daily from this office, Vernon S. Yallop, Manager. Telephone DOuglas 2-8311.



**T**HE STAINED GLASS MEDALLION reproduced on our cover this month is a representation of the Nativity, translated in terms of color and light. Forming the base medallion in a sanctuary window of the Church of St. Vincent Ferrer in Vallejo, California, this panel presents the story of the first Christmas according to ancient tradition. The glass craftsman's art during the 13th, 14th and 15th centuries followed closely the style of the illuminated manuscript, and in his glowing and sparkling windows we may see the simple but honest and direct interpretation of spiritual values through a material medium.

OUR COVER MEDALLION is part of a window — a modern window—that makes use of the same methods of design and fabrication that have been used for the past eight or nine centuries. The manger containing the infant Christ is shown, together with the figures of the Virgin Mary and St. Joseph who are disposed in positions of tender solicitude. The colors are rich primaries, blues, rubies and golds, picked out with little accentuating fragments of green and white.

*(Description of cover design by Harold W. Cummings of Cummings Studio, San Francisco)*

# Smart Design

## STURDY CONSTRUCTION

### *in Drinking Water Facilities*

MODELS that afford ease in the selection of the right type of drinking water facilities for the new buildings you are now planning are available in the complete line of distinctive HAWS Electric Water Coolers and HAWS Drinking Fountains. For the healthful protection of sound sanitation in drinking water... for that "invitation to use" appearance and for lasting satisfaction... specify the installation of HAWS Electric Water Coolers and HAWS Drinking Fountains.

*Write today for full information  
on HAWS Electric Water Coolers and  
HAWS Drinking Fountains.*

# HAWS

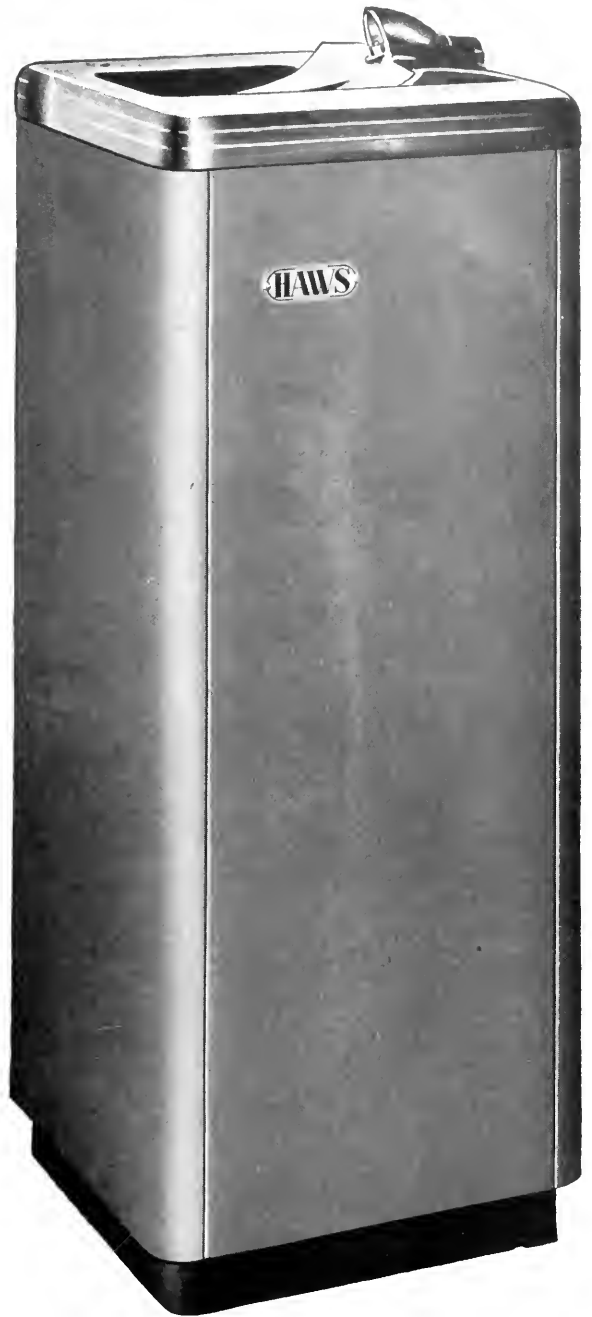

## ELECTRIC WATER COOLERS

### HAWS DRINKING FAUCET CO.

1808 HARMON STREET (SINCE 1909) BERKELEY 3, CALIFORNIA  
Agents and Sales Representatives in All Principal Cities

# Simpson

QUALITY SINCE 1895

BRINGS YOU A

*Termite-proof  
Rot-proof*

## INSULATING BUILDING BOARD



### COMPLETE PROTECTION

**T**HROUGH a process developed by our Research Laboratory, Simpson Insulating Building Board is treated during manufacture to render it resistant to termite attack, fungus growth, dry rot, mold, mildew and other microscopic organisms. By the Simpson process, every fiber of the board is coated uniformly with a non-toxic agent, harmless to humans and animals, so that the interior as well as the exterior is given *tested protection*. This is one of the many reasons why Simpson Insulating Board is especially suitable for dry

wall construction in various types of structures: as a floor insulation and for building and insulating farm structures such as poultry and laying houses, dairy barns, hog houses, brooder houses, fruit and vegetable storages.

### IMPROVED BUILDING QUALITIES

Made from the long and tough fiber of the matchless Douglas fir, the new Simpson Insulating Building Board has the advantage of *greater structural strength and better insulating properties.*

**Woodfiber Division • Simpson Logging Co.**  
Plant at SHELTON, WASHINGTON  
Sales Division: SIMPSON INDUSTRIES  
1010 White Building, Seattle 1, Washington



### ENTIRE PRODUCTION ALLOCATED TO WESTERN DEALERS FOR WESTERN BUILDING

*Discuss Your Needs with the Simpson Distributors Listed Below or Write Direct*

ARIZONA SASH, DOOR & GLASS CO.  
521 S. 9th Ave., Phoenix, Ariz.  
Phone: 3-3151

ARIZONA SASH, DOOR & GLASS CO.  
657 W. St. Mary's Road, Tucson, Ariz.  
Phone: 1699

CALIFORNIA BUILDERS SUPPLY CO.  
700 Sixth Avenue, Oakland 4, Calif.  
Phone: Highgate 6015

CALIFORNIA BUILDERS SUPPLY CO.  
19th & 5 Sts., Sacramento 14, Calif.  
Phone: 2-0788

CALIFORNIA BUILDERS SUPPLY CO.  
3180 Hamilton Ave., Fresno, Calif.  
Phone: 2-9470

CALIFORNIA PANEL & VENEER CO.  
955-967 So. Alameda St.,  
Los Angeles, Calif., Phone: Trinity 0057

CONTINENTAL LUMBER CO.  
P.O. Box 2042, Boise, Idaho, Phone: 450

ELLIOTT BAY LUMBER CO.  
600 W. Spokane St., Seattle, Wash.  
Phone: Elliott 8080

ELLIOTT BAY LUMBER CO.  
2712 McDougall St., Everett, Wash.  
Phone: Main 150

ELLIOTT BAY LUMBER CO.  
Box 188—Union Gap Station  
Yakima, Wash., Phone: 24671

EXCHANGE LUMBER &  
MANUFACTURING CO.  
P.O. Box 1514, Spokane 7, Wash.  
Phone: Glenwood 1621

ROST HARDWOOD LUMBER CO.  
Market at State St., San Diego, Calif.  
Phone: F-7224

LUMBER DEALERS, INC.  
T A Box 5222, Denver 17, Colo.  
Phone: Tobor 6141

LUMBER DEALERS, INC.  
108 South Main St., Pueblo, Colo.  
Phone: 4881

LUMBER DEALERS, INC.  
423 N. 33rd, Billings, Mont., Phone: 3911

MORRISON-MERRILL & CO.  
353 No. Park Street, Reno, Nevada  
Phone: 2-2196

NEW MEXICO COMPANY  
1401-15 North 12th St.,  
Albuquerque, New Mexico  
Phone: 3-1708

CHAS. E. SAND PLYWOOD CO.  
1106 N.W. 16th Ave., Portland, Ore.  
Phone: Atwater 6421

SIMPSON INDUSTRIES  
1610 E. Washington Blvd.  
Los Angeles, Calif.  
Phone: Prospect 6183

SIMPSON INDUSTRIES  
Shelton, Wash., Phone: Shelton 611

UTAH LUMBER CO.  
333 W. 1st St., Salt Lake City 9, Utah  
Phone: 4-4318

WESTERN DOOR & SASH CO.  
5th & Cypress St., Oakland 7, Calif.  
Phone: Templebar 8400



"There's nothing more **MODERN**  
than a **GAS**-equipped kitchen"\*

**\*Any ARCHITECT or BUILDER can make that  
statement, backed by OVERWHELMING EVIDENCE:**

the beauty of line, the exclusive advantages of today's  
automatic gas ranges . . . with self-lighting burn-  
"high-low" flame-flexibility, clock control, oven  
control, "cool-kitchen" insulation and countless  
other features . . . all dear to the heart of today's  
"kitchen-conscious" homemaker.

- the attractive design, trouble-free long life and  
*silent* operation of the new gas refrigerator, (*no mov-  
ing parts* in the freezing system) with its huge frozen-  
food compartment and galaxy of other advantages.
- the recognized superiority of the automatic gas  
water heater, always dependable and economical.

The West Prefers  
**GAS** 

Design your kitchens around these new-day *gas* appliances,  
with thought for step-saving, "assembly-line" food preparation . . .  
and you'll bank dividends of good will to draw upon in the  
form of *more jobs, new clients!*

# Specific Need... Standard Window

—A TYPICAL MONEY-SAVING SOLUTION WITH FENCRAFT

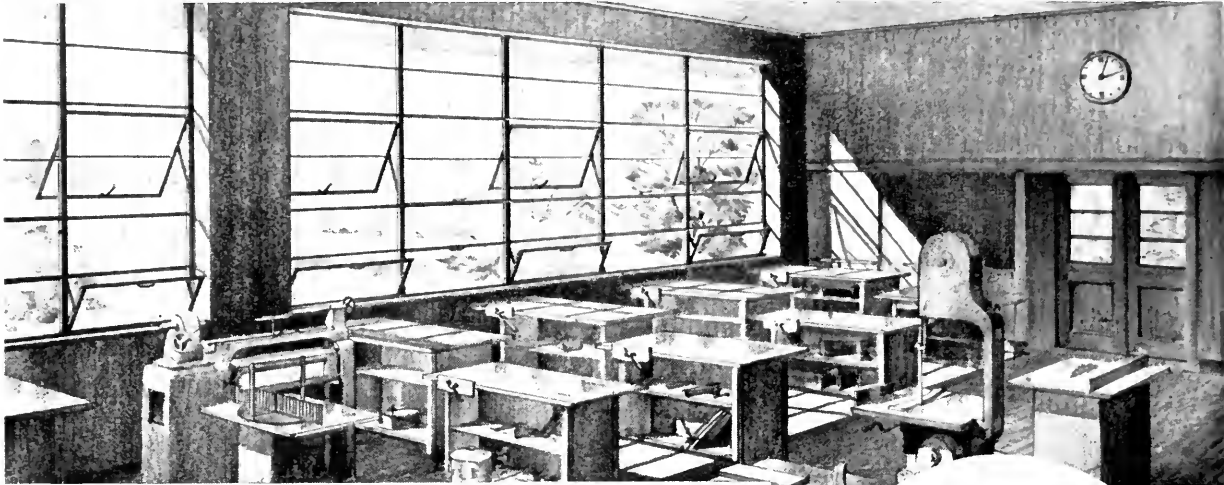

This school training shop exemplifies the versatility of Standard Fenecraft Windows. It calls for abundant daylight . . . plenty of ventilation and good control of it. The use of medium size panes is recommended for easy, low-cost glass replacement. Sill vents that discourage leaning out of windows are desirable.

Standard Fenecraft Windows provide these benefits—and more. Their trim beauty enhances both inside and outside appearance. They provide permanently easy operation, safe cleaning, lasting weather-tightness, firesafety and low maintenance costs.

*Standardization means economy . . .* in first cost and installation. Use of uniform installation details, plus co-ordination of window dimensions with those of wall materials, result in minimized installation costs.

All three types of Fenecraft Windows—Casement, Projected or Combination—fit the same size openings. Window openings can be drawn into early plans, permitting later selection of window type without redrawing of plans.

Fenecraft Windows are built by craftsmen of America's oldest and largest steel window manufacturer. Quality appearance highly recommends them for the finest of buildings. Standardization economics make them practical for buildings of all types. For details, mail the coupon.

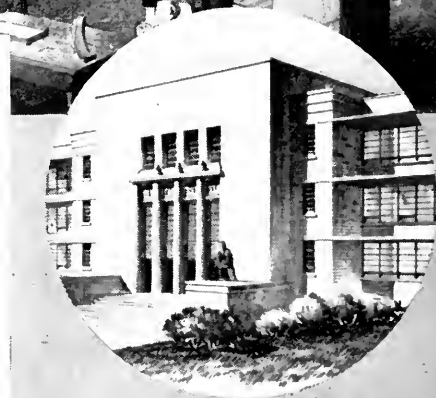

## Suggestion:

**In a school workshop, achieve large daylighting areas and excellent ventilation control with combined units of Fenecraft Intermediate Projected Windows, such as Type 418 (illustrated).**

**Fenestra**

CASEMENT      PROJECTED      COMBINATION

FENCRAFT INTERMEDIATE STEEL WINDOWS

Detroit Steel Products Company  
Dept. AE-12  
2262 East Grand Blvd.,  
Detroit 11, Michigan

Please send me data on types and sizes of the new Fenecraft family of Fenestra Windows:

Name \_\_\_\_\_

Company \_\_\_\_\_

Address \_\_\_\_\_

# NEWS AND COMMENT ON ART

## UNIVERSITY OF OREGON SCHOOL OF ARCHITECTURE

Mark R. Sponenburgh, chairman of the exhibitions for the School of Architecture and Allied Arts at the University of Oregon, has announced the following Exhibit for January 1948.

Arts of Early People which is the Anthropology Collection of the University of Oregon, and very comprehensive in scope.

The Exhibit will open January 10 and continue until January 29.

## MILLS COLLEGE CERAMIC GUILD

The annual Christmas Show of the Mills College Ceramic Guild is being held this year at Fenner Fuller's Gallery, 614 Grand Avenue, Oakland, California.

Among the things being shown are many decorated and functional pieces consisting of bowls, pitchers, vases, plates, covered jars, and ceramic sculpture.

Included in the Show are work by Elena Montalvo Netherby, Prof. F. Carleton Ball, Jade Snow Wong, Ruby O'Burke, Florence Bruntjen, Esther Fuller, Edna Stoddart, Helen Gester, Margaret Jipp, Helen Mitchell, Thel and Claude Wilson, Robert and Nancy Clough, Marie Wilson, Vernon Coykendall, and Fenner Fuller.

## M. H. DE YOUNG MEMORIAL MUSEUM

The program of exhibitions and events for the month of December, as announced by Walter Heil, director, will include the following:

EXHIBITIONS: PAINTINGS by Paul A. Schmidt, PAINTINGS AND DRAWINGS by Carlyle Brown, PAINTINGS by Miklos Suba, PAINTINGS by Hayes Lyon, CHINESE PAINTINGS by Tseng Yu-Ho, and "THE YOUNG IN ART" consisting of an exhibition of drawings and paintings by children in the Museum's art classes.

EVENTS: Saturday classes for children, conduct-

(See Page 11)

## CHANA ORLOFF

### M. H. DE YOUNG MEMORIAL MUSEUM

GOLDEN GATE PARK  
SAN FRANCISCO, CALIFORNIA

Blazing her own trail and never subscribing to any academic forms or modern fads—Chana Orloff's personality breathes of strength with an almost masculine virility—her life alive with growth; a record of challenges met; a record of achievement realized.

Of Russian origin and French by adoption, she owes little to any particular teacher. Studying for a short period at the Ecole Des Arts Décoratifs in Paris (she was a recalcitrant pupils), she seems to have absorbed more from her favorite Egyptian and Gothic models than from any academic teaching.

Chana Orloff commenced to exhibit in public in 1913, and has since confirmed her reputation in exhibitions at the Salon d'Automne, the Independants, and the Salon des Tuileries in Paris, and also in Brussels and in New York. She is one of the favored minority who are represented in the French Government's collection. France made her an officer of the Legion of Honor.



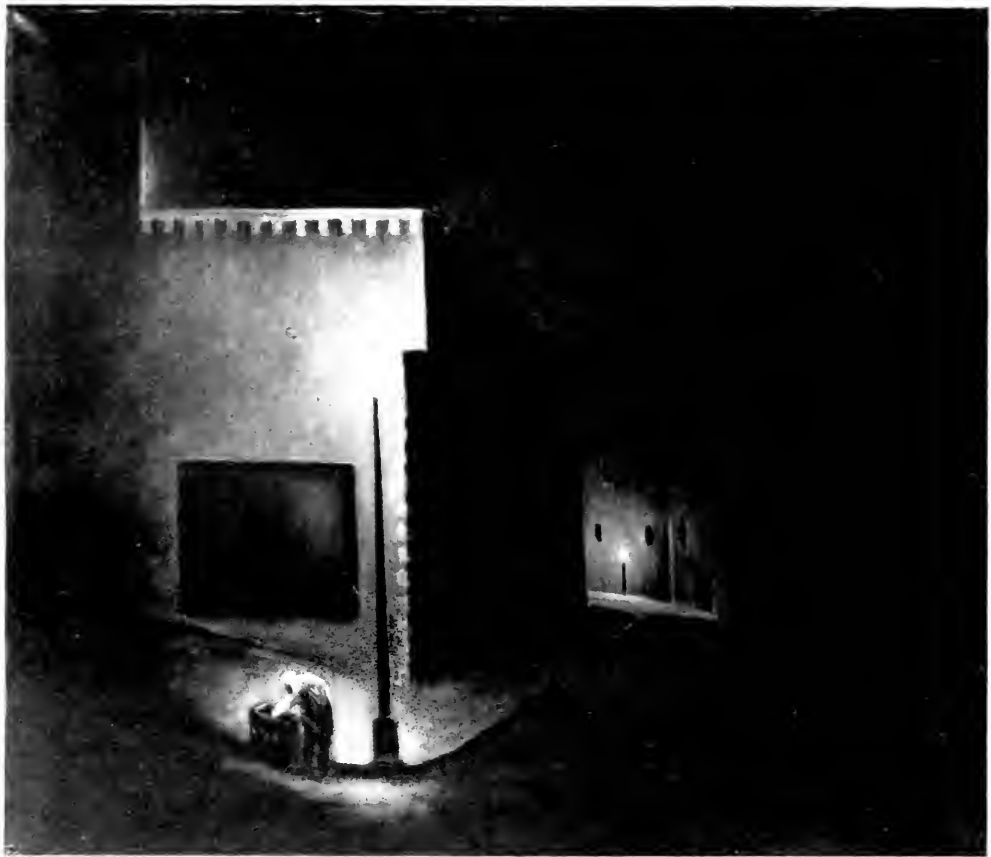

**NIGHT SCENE**

**By MATTHEW BARNES**

### SAN FRANCISCO MUSEUM OF ART

NIGHT SCENE by Matthew Barnes is an old favorite at the San Francisco Museum, and forms part of the Albert M. Bender Collection.

When Albert Bender, active art patron, died in 1941, he left most of his collection of modern art to the Museum, which he had always patronized liberally during his lifetime. Every year in December it is the Museum's custom to have an extensive showing of the Bender collection in all its galleries.

NIGHT SCENE has been on exhibition for the greater part of a year, because of its many admirers. Mr. Barnes, originally from Scotland, is well known, locally and nationally, for his romantic and mystical subjects and the mysterious moonlit atmosphere of his boldly conceived oils. He is presently exhibiting in Washington with an invited group of West Coast artists, personally picked by Duncan Phillips for the Phillips Memorial Gallery. This exhibition will subsequently go on a six months tour of Eastern and Mid-Western cities.



(From Page 9)

ed by Miriam Lindstrom. These classes will be discontinued during the holidays, December 20 to January 3, and will be resumed on January 10th.

### SAN FRANCISCO MUSEUM OF ART

The schedule of events and exhibitions for December will include the following:

**EXHIBITIONS**—Paintings by Keith Martin; Picasso in The Museum Collections; Selections from the Albert M. Bender Collection; Orozco in the Museum Collections; Twenty-Second Annual Exhibition of the San Francisco Women Artists; Thirty-Fourth Annual Exhibition of the California Society of Etchers; Art as Therapy for Veterans; and The Christmas Sale.

The Museum will be closed for renovation from December 29th through February 15th, however a full schedule of exhibitions and activities will be resumed following the Museum's reopening on February 15th.

### CITY OF PARIS ART IN ACTION

December Exhibitions will include An Exhibition of Watercolors by Standish Backus, Jr., Joseph Knowles and George Post. This exhibit will be in the Rotunda Gallery, 4th floor.

The Art in Action Shop will feature "Pictures of the Month" by Ruth Armer. Weav-rite Loom demonstration; Pure silk scarfs by Asher of London, designed by Derain, Henry Moore, Jean Hugo and others.

Other displays will include Casseroles, Lucite trays, Aluminum place mats and candles, pottery settings, and other items of particular interest at this season of the year.

### CALIFORNIA SCHOOL OF FINE ARTS

Registration is now open to prospective students wishing to enroll for the Spring term.

The new 18-week semester will open on Monday, January 5, 1948.

The Art School will have a faculty of thirty instructors teaching in the fields of orientation, fine arts, design for commerce and industry, and photography. A number of advanced courses in the commercial department, including those in wall decoration, advanced lettering and agency and client, are being offered

Both day and night classes will be given, as well as special Saturday sessions for children.

### CALIFORNIA PALACE OF THE LEGION OF HONOR

Thomas Carr Howe, Jr., Director of the California Palace of the Legion of Honor, Lincoln Park, San Francisco, has announced the following schedule of exhibitions and special events for December:

**EXHIBITIONS:** The Age of Enlightenment—Lent by Life Magazine, Closing December 15; Photographs by Aaron Siskind, Closing December 31.

Second Annual Exhibition of Painting, Closing January 4: The exhibition, containing approximately 300 works in oil, provides a cross-section of the painting which is being produced in the United States today. The show is a departure from the First Annual, held in the Spring of 1946, in that one-half of the entries were invited while the remainder were selected by jury from paintings submitted voluntarily by artists living in the United States. Both the invitational and juried entries were eligible for awards. The Jury of Selection and Awards was composed of Dr. Ray Faulkner, Head of the Art Department, Stanford University; Mr. Wright Ludington, Trustee, Santa Barbara Museum of Art; and Mr. Arthur Millier, Art Critic, Los Angeles Times.

The Alma de Bretteville Spreckels Collection of Sculpture by Auguste Rodin.

The Mildred Anna Williams Collection of Paintings, Sculpture, Tapestries and Furniture.

The Collis Potter Huntington Memorial Collection of 18th Century French Paintings, Sculpture, Tapestries, Furniture and Porcelain.

**EDUCATIONAL ACTIVITIES:** Regular Saturday morning art classes for children 4-15, will be held at 10:00 a.m. under the direction of Katharine L. Parker, Lilly Weil Jaffe and William T. Getman. Admission free.

The painting class for adults, under the direction of William T. Getman, will be held at 2:00 p.m. on Saturday. Admission free.

Gallery tours of the Second Annual Exhibition of Painting at 2:30 p.m. each Wednesday and Friday. Conducted by Katharine L. Parker.

### M. H. DE YOUNG MEMORIAL MUSEUM

The de Young Museum announces the opening on December 9th of an exhibition of paintings and drawings by CARLYLE BROWN, 28-year-old California-born artist. Brown, who served in the Navy during the war, has just had his first one-man in New York City.



1

BAYLIS

---

---

SCULPTORS

---

---

1. Joch Schineer
2. Blanche Phillips
3. Elah Hale Hayes
4. Kisa Beck
5. F. Alston Swift
6. Clair Falkenstein

2





# THE GARDEN DESIGNER SETS THE STAGE

By RUTH JAFFE, A.L.A.

Sculpture in the hands of our contemporary artisans has become a simple pleasure which everyone may enjoy. And a garden offers a particularly sympathetic setting for this form of art which is so broad in mood and interpretation.

In the recent Marin Art and Garden Show at Ross, California, members of the Association of Landscape Architects collaborated with sculptors of the Bay Area to express various conceptions of this idea. The show took place in the garden of an old estate which offered the advantage of a natural setting, rather than an artificial enclosure. Small areas were chosen by the collaborators, and designed appropriately to receive the pieces of sculpture.

In the planning, architects and sculptors considered numerous elements for the successful integration of sculpture into the garden. In cases where the piece already existed, the architect gave consideration to the form of the sculpture which suggested the mood and pattern of the garden. On the other hand, some pieces of sculpture were especially designed to fit into a particular garden scheme. In all cases the sculpture was placed with a sense of space, scale, light and shadow, and accompanying textures and color, both in the plant materials and construction materials.

In arranging the work of the sculptor in the garden, there is unlimited opportunity to express

BAYLIS



4



14

changing moods, even as the garden itself changes with the seasons. The day of the massive stone figure planted for eternity amid greenery is gone. The art lover today may be indulgent of his growing appreciations. He may, at a whim, substitute a mischievous Puck for a figure more placid or serene.

It has been felt that sculpture or other art forms have been too esoteric for the layman to use—but this is no longer so.

Art excludes no one, for it is but the skillful construction of man's ideas; the things that man creates for his use and enjoyment, and sculpture, as the Marin Art and Garden Show so eloquently demonstrated, is ideas which may be constructed in materials that happily incorporate themselves into an outdoor setting.

3

5



ARCHITECT AND ENGINEER



6

ROBINSON

---

---

LANDSCAPE ARCHITECTS

---

---

1. Eckbo, Royston & Williams
2. Ruth Jaffe
5. Helen Van Pelt
6. Eckbo, Royston & Williams

# Research In Engineering Seismology

**A Report Presented to the Members of the Structural Engineers  
Association at the Yosemite Annual Convention**

**By G. W. HOUSNER, Professor  
California Institute of Technology,  
Pasadena, California**

It is well known to engineers that there are a number of unsolved problems in engineering seismology. These problems have a direct bearing on public safety and the economic construction of buildings within the major earthquake zones of the United States. The problems have naturally aroused the interest of engineers, geologists and seismologists and considerable work has been directed toward their solution. It is, however, rather difficult to present an adequate description of research in engineering seismology. There is in existence no organized program of research on the engineering problems in seismology. A relatively small number of men have been actively engaged in such work and the results of their work have not been publicized and, in fact, much of their work has never been published. The work that has been done in the past has covered widely divergent aspects of the general problem, ranging from statistical studies of earthquake damage to mathematical analyses of strong motion earthquakes. It is not possible to present an adequate description of this work in a limited time, and it is probably not desirable to attempt it since structural engineers are chiefly concerned about the development of sound rules to govern the design of structures to resist earthquakes. The present method of designing structures to resist specified lateral forces represents a great advance over prior practice but, as is well known, there are many questions whose answers must be found before the design rules have attained the optimum in

safety and economics. I shall give a brief description of research that has been aimed at obtaining ultimately sound rules for the design of structures. My remarks will apply chiefly to work carried on at the California Institute of Technology.

A study of the general problem reveals two promising methods of approach. The first method is to make statistical studies of damage incurred during earthquakes and the second is to make a more or less complete analysis of the dynamical behavior of structures when subjected to strong motion earthquakes. The chief difficulty in both of these approaches is the large number of variables and uncontrolled factors that are involved. This means that a statistical study must be based upon large groups of data which will be available only after the occurrence of a sufficiently large number of earthquakes. Although an analytical study is complicated by the many factors entering the problems this approach appears to be capable of furnishing the desired answers.

The analytical solution of the problem poses the question. What will be the stresses and strains imposed upon a structure when it is subjected to an earthquake? This problem has two special features. In the first place no two earthquakes are exactly alike, and it is not possible to predict the ground motions that will occur in a future earthquake. In the second place, there is a wide variety of types of structures that differ from each other

(See Page 31)

# EMERGENCY COMMITTEE PROGRAM for COMMUNITY DISASTER RELIEF

**Structural Engineers Association of California—  
Report to Members**

**By JOHN G. LITTLE, Superintendent  
Bureau of Building Inspection,  
City and County of San Francisco**

The program of the Emergency Committee is a very simple one, but I think it will be effective and it will continue to live long after the present members of the Committee have gone out of office.



**John G. Little**

The Emergency Committee is concerned with community disaster relief. Community disasters occur from many causes, such as earthquakes, floods, enemy bombings, hurricanes, tidal waves, etc. I think our proposed participation in disaster relief will fit in equally well for any disaster that may occur. We, in this vicinity, think largely of

earthquakes as a disaster cause.

It seems to the members of the Committee that the value of the structural engineer in disaster relief will be largely through his ability to determine whether it is safe to enter a structure that has been damaged by disaster, and to determine what temporary precautions must be taken to enter such structures, and to determine what structures should be immediately demolished to prevent possible injury to persons who might enter the structure or approach its vicinity.

---

*EDITOR'S NOTE: This paper delivered by John G. Little, in an address before members of the Structural Engineers Association during the Association's recent annual meeting at Yosemite National Park.*

It is possible that the structural engineers in the immediate disaster location may be so completely occupied in taking care of their own families that they might not be available to assist the general public.

The structural engineer, to be of any particular value in disaster, must be located quickly, and since all communications, except possibly radio and messenger service, may be momentarily put out of business, the most important thing for the structural engineer is that he make known his whereabouts.

With this in mind, the Structural Engineers Association of Northern California has agreed to furnish a roster of its organization to every building inspector in every community, for all communities from Bakersfield to Chico inclusive, and we expect to form a committee of one or more members of our Association to contact the building inspector in each community to the end that they too will be the nucleus of a Committee for disaster relief in each community.

The principal thought in the mind of the Committee is to make the office of the building inspector a rallying point where all available structural engineers will attempt to meet or send in notification of their whereabouts.

This program, of course, could not be carried out without the cooperation of the building inspectors, so the matter was taken up with the Central District Organization of the Pacific Coast Building officials Conference who have enthusiastically agreed to cooperate to the fullest extent with the

(See Page 33)



WESTERN VIEW OF THE MAIN PLANT

# New Plant Challenge Cream and Butter Association

Berkeley, California

ALBEN R. FROBERG, Architect

## NORTH ELEVATION—

Front view showing main entrance to executive offices which are indicated by the two rows of windows at the rear of the building.





THIRD ST (SPRR)

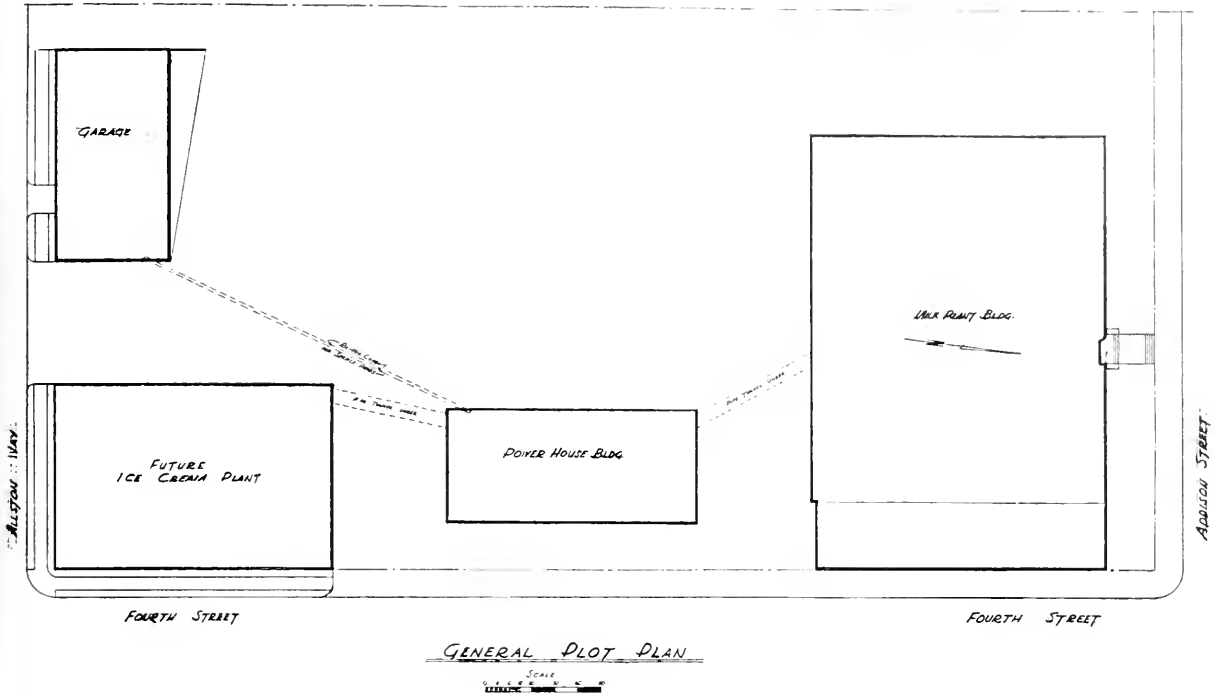

The new processing plant of the Challenge Cream and Butter Association at Berkeley, California, resolved itself into the architect planning for the eventual construction on a lot 246 feet by 482 feet of four buildings—with three units, the Milk Processing Building, the Power House and

the Truck Maintenance Building, or Garage, being built at this time while the fourth unit, the Ice Cream Plant will be developed later.

The Milk Processing Building, 128 feet by 190 feet of reinforced concrete, houses the activities involved in the processing of milk, including homo-

**GARAGE FOR MAINTENANCE AND REPAIR OF DELIVERY TRUCKS**

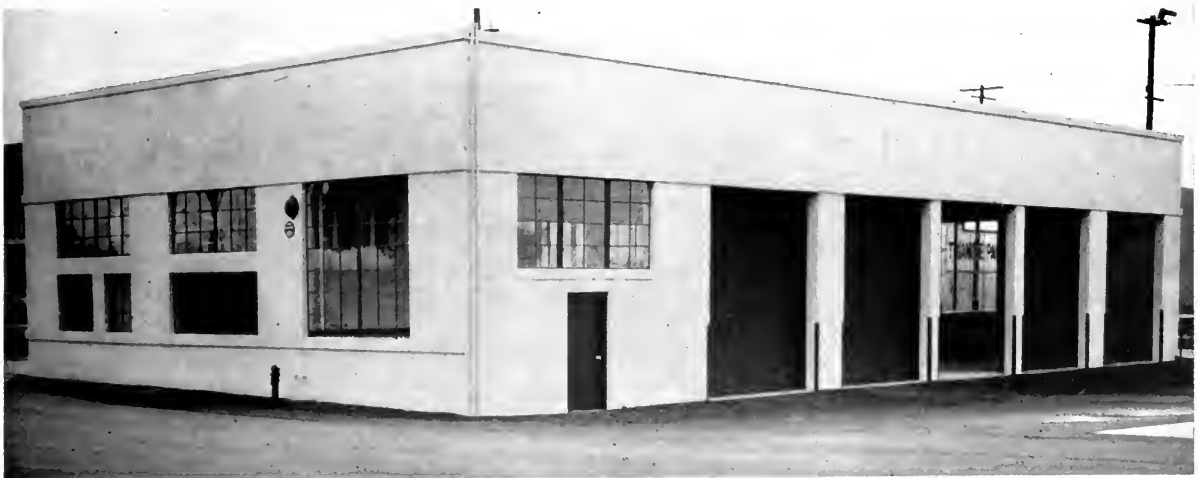

# CHALLENGE CREAM & BUTTER . . .

genizing and pasteurizing and the bottling and packaging of milk for local delivery. The structure also provides refrigerated storage space for milk products such as cheese and butter.

Administration and executive offices, sanitary facilities and recreational space for employees has also been provided for in the main processing building.

The Power House structure, which is 50 feet by 110 feet and of reinforced concrete, contains a boiler room, a compressor room, and a work shop for general plant maintenance, while on the roof over the compressor room are located two 80-ton

## CHALLENGE CREAM & BUTTER PLANT Berkeley, California

The following firms, participants in the construction of the new Challenge Cream & Butter Plant, have display advertisements in this issue:

- ARCHITECT: Alben R. Froberg, A.I.A.
- MECHANICAL & DESIGN ENGINEER: C. B. Tetherow
- PLANT ENGINEER: Harvard L. Francis
- CONTRACTORS: Christensen & Lyons
- PAVING: Ransome Company
- MILLWORK: Clinton Mill & Lumber Company
- GLASS BRICK & CONCRETE BLOCKS: A. Hallert
- PLUMBING: E. C. Braun Company
- HEATING & VENTILATING: Pacific Heating & Ventilating Company
- ELECTRIC WORK: California Electric Company
- PAINTING: Allied Painters & Decorators
- PAINT MATERIALS: Glidden Company
- METAL DOORS: McKune Metal Products Company
- ELEVATOR: Moody, Swazey & Rowe
- MACHINERY INSTALLATION: Condict Company

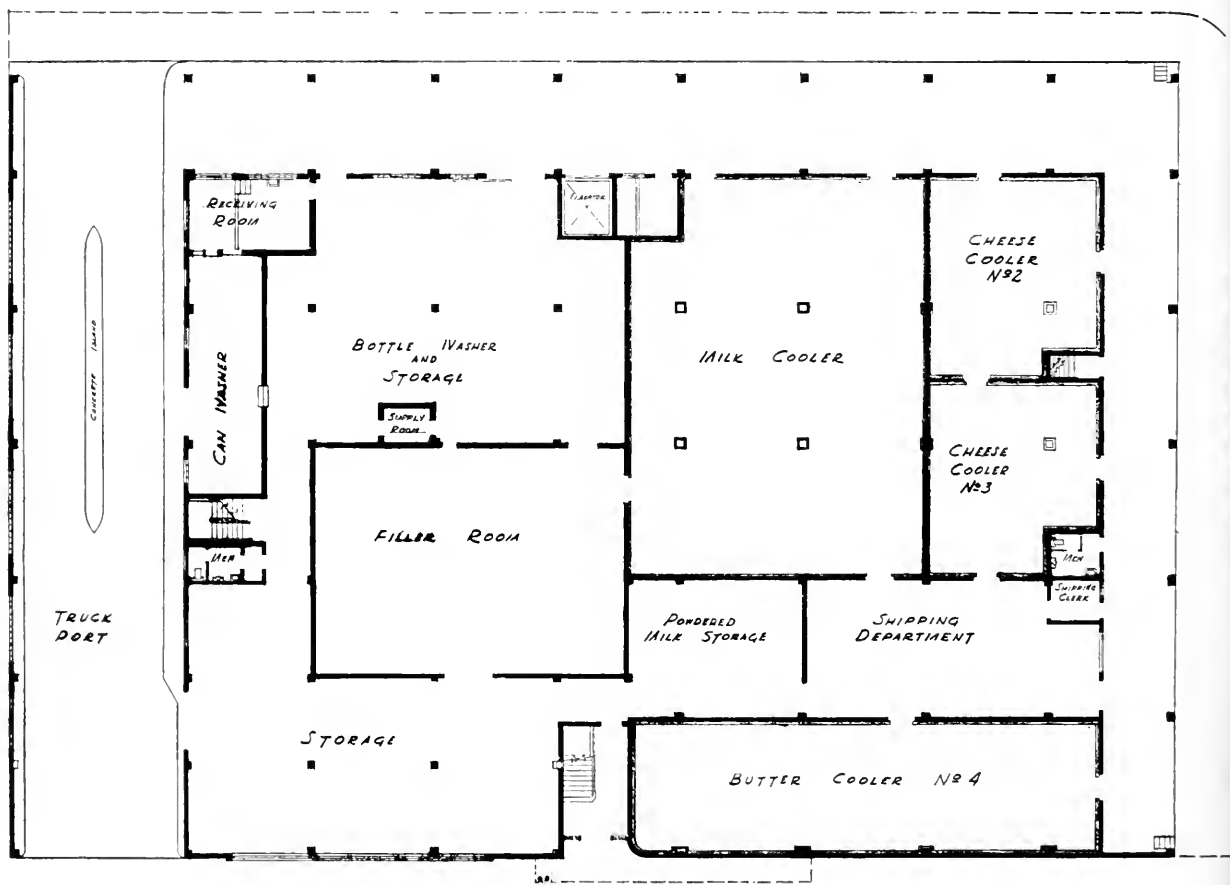

FIRST FLOOR PLAN  
SCALE  
1/4" = 1'-0"

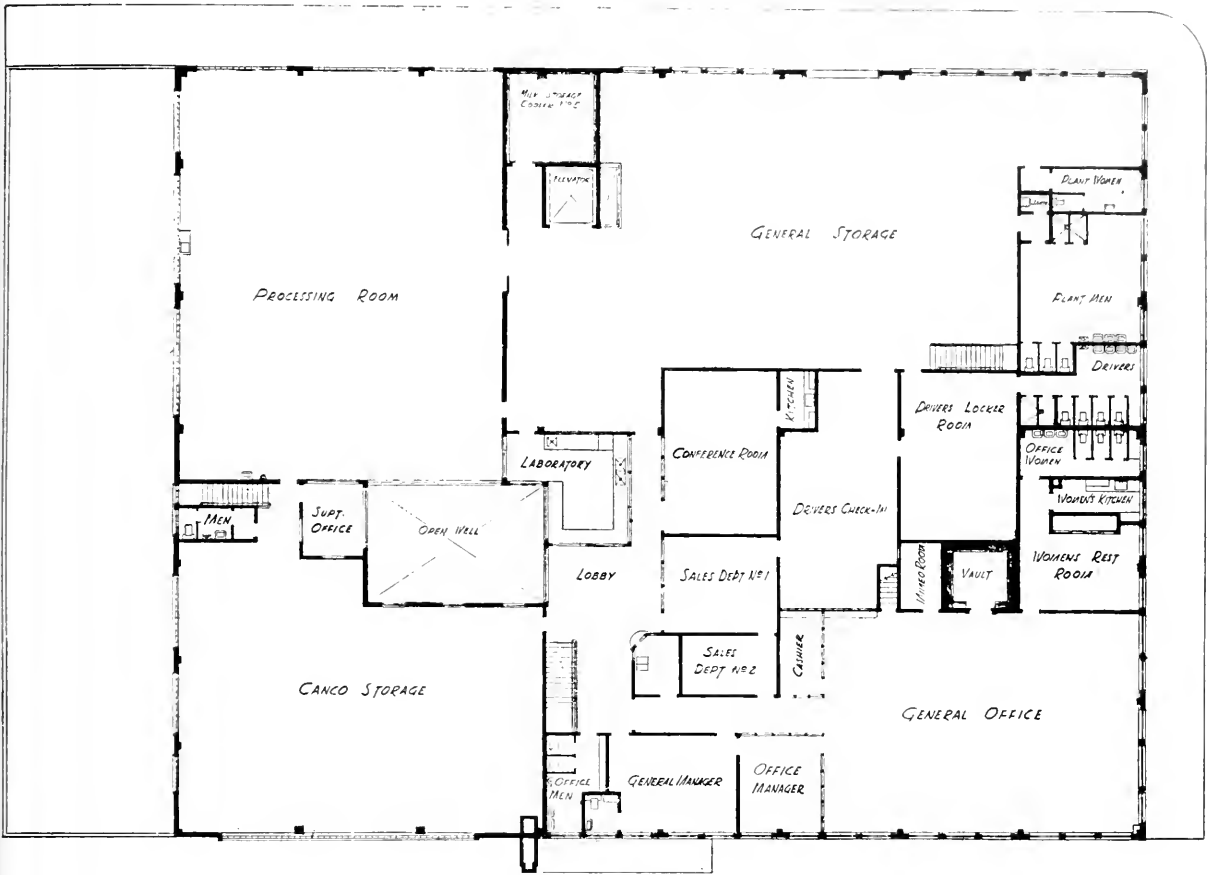

SECOND FLOOR

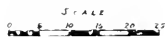

evaporative condensers. There are at present two 150 horsepower automatic natural gas boilers installed with provision being made for a third, and space has been allotted in the compressor room for additional refrigeration required when the contemplated Ice Cream Plant is put into operation. Also included is a transformer vault and the main electrical switchboard. Steam, hot water, refrigeration, and the electric energy is supplied to the processing plant through a concrete underground tunnel.

The Garage is a building of reinforced concrete 50 feet by 93 feet used for the maintenance and repair of over 100 local delivery trucks operated by this particular plant. These trucks will be parked in the paved yard area surrounded by a 7-foot wire fence when not in operation. The building facilities also include a shop foreman's office, grease racks, washing and cleaning racks, and nearby are two 1100-gallon storage capacity gasoline tanks with pumps.

The main part of the plant, however, is the milk



**STAIRWAY:**

Looking down stairway towards main entrance from general executive offices which are located on the second floor of the main plant building.

processing building. Here all the refrigerated rooms and heavy storage facilities are located on the ground floor, which incidently has been raised to about three feet above the natural ground grade to form the truck loading docks on the west and south sides of the yards. A covered passage, or driveway, is provided on the east side of the

building adjoining the street or receiving side where fresh milk from the dairy farms is received and weighed. The milk is usually delivered to the plant in large truck and trailer trucks, two of which can be accommodated at the same time.

From the first floor receiving room, adjoining the

---

**MACHINERY INSTALLATION  
AND  
GENERAL RIGGING  
FOR  
CHALLENGE CREAMERY PLANT**

**BY  
CONDICK CO.**

**RIGGERS — ERECTORS  
TRUCK CRANES**

Berkeley

California

*Challenge Creamery*  
**CONCRETE BLOCKS**

**AND  
GLASS BRICK**

THE WORK OF

**ALBERT HALLERT**

**2500 Sixty-fifth Ave., Oakland**

**Sweetwood 8-1047**

**GENERAL OFFICES:**

Of the Challenge Cream and Butter Association, Berkeley, California, include many modern features—note acoustical ceiling and three rows of blue and white fluorescent lights.



covered driveway, the fresh milk is pumped to the second floor processing room into large receiving tanks lined with stainless steel. Here it is subjected to pasteurization and homogenizing, the cream is separated, butter is churned, and other milk products are developed.

The milk which is designed for bottling and packaging flows by gravity back to the first floor filler room where automatic machines fill the bottles and cartons, and then automatic conveyors take the finished products to the milk storage cooler. From here they are again taken by conveyor

**ELEVATOR**

By  
**MOODY, SWEAZEY & ROWE**

Electric Elevators  
Oildraulic Elevators  
Dumbwaiters  
Motorstairs

814 Alice Street

Oakland 7

TWinoaks 3-4562

**MILLWORK**

**Challenge Cream and Butter Plant**

Supplied by

**CLINTON MILL & MFG. CO.**

Millwork • Sash • Doors  
Frames and Cabinets

345 E. 7th Street, Oakland 6, Calif.

Telephone: GLencourt 1-9480

**LABORATORY:**

**A small corner of the ultra modern laboratory showing the autoclave for sterilizing laboratory utensils.**



to the loading docks to be loaded into delivery trucks.

All floor and wall surfaces where milk or milk products are stored or handled are of tile or washable enamel. All piping and tanks through which milk passes are of stainless steel. A fully equipped and staffed technical laboratory maintains constant tests on the quality of the products. Such tests and the entire operation of the plant is in conformity with local city, state, and federal health department regulations.

Certain portions of the second floor of the Processing Plant are rather heavily loaded to about

400 pounds to the square foot, and it was found that a flat slab type of construction was most feasible.

All the structures have concrete walls and floors.

The General offices, executive offices, and plant personnel areas are fluorescent lighted to about 50-foot candles and have automatic controlled heating and ventilating systems.

In all of the construction provision has been made for further expansion of plant facilities by the installation of additional equipment as the need arises.



**POWER HOUSE:**

**Equipped with two 150 h.p. steam boilers and battery of modern type compressors.**

## GENERAL PLANT DATA

**Receiving Driveway** — 28' wide,  
Clearance 13'10"

For receiving milk from tankers  
and 10 gal. cans

Power conveyor from driveway to  
receiving room

Can cover loosener

Milk pump for unloading tankers

Service island, dividing driveway

Two steam and water mixing sta-  
tions, for washing trucks and  
tankers

Signal system to give warning and  
stop milk pump when raw milk  
storage tanks are full

**Receiving Room**—12'x20'

Tile — floor, ceiling and walls—  
joints in tile floor filled with tegul  
(an acid resisting grouting)

Weigh scales

Weigh tank s.s. (1000#) with auto-  
matic dump valve

Sump tank—200 gal. with control  
to stop and start milk pump

Milk pump

Signal system to give warning and  
stop milk pump when raw milk  
tanks are full on second floor

Stainless steel refrigerated sample  
cabinet

Incoming power conveyor. Full  
can capacity 38-10 gal. cans.  
With can stop and can dump

Outgoing power conveyor. Empty  
can capacity, to truck 54-10 gal.  
cans

Total cans on conveyor system  
and can washer, 107-10 gal. cans

Lavatory

Steam and water mixing station

**Can Washer Room**—12' x 39'

Can washer—13 cans per minute  
—Power conveyor to truck in  
driveway

Can washer vented through roof  
with fan

Space—12' x 18' for stacking emp-  
ty cans

Steam and water mixing station

4' tile wainscot—tile (tegul) floor

## Technical Paint Application and General Painting Work of Durable Beauty

PERFORMED BY

**Specialized Craftsmen**

OF THE

**ALLIED PAINTERS & DECORATORS, INC.**

**CONTRACTORS**

OAKLAND 1, CALIFORNIA

## Color Styling

FOR THE NEW CHALLENGE MILK AND BUTTER PLANT,  
BERKELEY, CALIFORNIA, EXECUTED BY

**MR. CARL SMEDLEY**

GLIDDEN'S OUTSTANDING COLOR EXPERT, AT THE  
REQUEST OF THE ALLIED PAINTERS AND DECORA-  
TORS, INC., PAINTING CONTRACTORS ON THE JOB.

THE GLIDDEN COMPANY IS PLEASED THAT THE  
OWNERS OF THIS MODERN INDUSTRIAL PLANT HAVE  
FOLLOWED MR. SMEDLEY'S SUGGESTIONS  
THROUGHOUT.

*The Glidden Company is offering free  
this valuable color advice to all  
architects, engineers and contractors.*



**SAN FRANCISCO**

## CHALLENGE CREAM & BUTTER . . .

### **Bottle and Case Washing Room—43' x 59'**

Power conveyor from dock to case washer—to filler room

Space for stacking empty cases — returned from route trucks

Water and steam mixing station

Electrical switchboard for first floor

Small can washer

Bottle case washer

4' tile wainscot—tile (tegul) floor

### **Filler Room—37' x 51'**

Power conveyor from case washing room—to fillers—to milk cooler

1—No. 176 Canco filler—capacity 100 qts. per min.  
1—No. 75 Canco pt. and ½ pt. filler—capacity 75 packages per min.

1—Jr. D Purepak filler—(½ gal.) 25 packages per minute

1—Jr. G Purepak filler qts, pts and ½ pts—35 packages per minute

1—4 valve can fillers

Space for future glass filler

4—Water and steam mixing stations

Drinking fountain and lavatory

2 Exhaust fans in skylight

Tile (tegul) floor, walls and ceilings

### **Ice Cream Mfg. Room—(temporary) 22' x 29'**

Two ice cream freezers—150 gal. per hour, each

2 Flavor tanks

Pass door to hardening room

Exhaust fan for ventilation

Water and steam mixing station

### **Milk Storage Cooler—48' x 65'**

4" corkboard 35°

3 Niagara Blower Units — (8.5 tons refrigeration each) with automatic controls and air ducts

## Heating & Ventilating

Equipment in  
CHALLENGE CREAMERY PLANT  
Berkeley, California

Installed by  
**PACIFIC HEATING AND VENTILATING CO.**  
Heating, Piping, Air Conditioning  
Contractors

288 Whitmore Street

Oakland, Calif.

# CHRISTENSEN & LYONS

## GENERAL CONTRACTORS



### *Industrial and Commercial Buildings*

The New

**CHALLENGE CREAMERY PLANT**

One of our recent contracts



Power conveyor from filler room to storage space—  
to loading dock  
2 water and steam mixing stations  
4' tile wainscot—tile (tegul) floor

**Shipping Dept. and Shipping Clerk Office**—23' x 48'  
For out-going merchandise—special del., etc.  
Motor for Lamson tube equipment

**Ice Cream Hardening Room**—8" cork—21' x 38'  
One Niagara Blower Unit—7.5 ton, 30° below zero

**Conference Kitchen**  
For preparing lunches — refreshments for various  
meetings  
Ample cupboard space — space for stove — Pass  
door to Conference Room  
Asphalt tile floor

**Laboratory**—14' x 18'  
Fully equipped for making all necessary tests of  
all samples of milk, ice cream, etc.  
Tile walls and ceiling—asphalt tile floor  
Refrigerated space for samples  
Ventilating fan

## CHALLENGE CREAM & BUTTER

**Canco Storage**—38' x 61'  
Storage space for the canco paper bottles which  
are fed from this room to the filling machines by  
chutes

The canco packages are received in the driveway  
and elevated to this room by belt conveyor  
which is reversible

**Plant Supt. Office**  
Has full view of operations in the processing filler  
room, Canco storage and laboratory  
Asphalt tile floor

**STAINLESS STEEL**  
**CHALLENGE CREAMERY PLANT**  
Berkeley, California

Installed by  
**McKUNE METAL PRODUCTS CO.**  
ENGINEERS and FABRICATORS

266 Tehama Street                      San Francisco

**INDUSTRIAL  
PAVING**



Ransome Company has for many years specialized in all types of paving for industrial and commercial concerns. We are experienced and prepared to construct paving for all types of commercial uses—such as—large parking areas, tennis courts, roadways, driveways—in fact, any type of pavement. Our recommenda-

tions are free and we are at all times willing to give specifications and estimates.

If you have a paving problem of considerable area to give you maximum all-season use, phone RANSOME COMPANY, OLYmpic 2-3600.

## RANSOME COMPANY

*Designing and Constructing Engineers*

4030 HOLLIS STREET

EMERYVILLE, CALIFORNIA



## CHALLENGE CREAM & BUTTER . . .

### Pipe Tunnel

Connecting processing building with power plant  
All pipe—steam, hot and cold water, ammonia refrigeration. Compressed air, electric conduit etc., are run through this tunnel in the open—The tunnel is 5'-0" x 6'-0" high x 60' long.

### Boiler Room—37' x 50'

Two—150 HP fully automatic Erie Economic Boilers—burning natural gas or oil  
Space for one more boiler  
Boiler feed pumps

Fuel oil heating & pumping set  
Boiler feed water preheating & storage tank  
Hot water heating system  
One steam and water mixing station  
Water softening and treating equipment

### Shop Room—30' x 50'

Engineers office—toilet, shower and lockers  
Vault, inclosing 3 electrical transformers  
Mez. floor. Work shop, etc.  
Main electrical power panel on Mezzanine above transformer vault

### Compressor Room—43' x 50'

Four 7½ x 7½ ammonia compressors, One 6" x 6" standby  
Vertical pipe shaft from tunnel  
Two air compressors—Ammonia receiver  
One steam and water mixing station

### Garage

Shop foreman's office, store rooms, toilet and shower rooms  
Two pits—for grease and repair work, six steel rolling doors  
Drinking fountain  
Wash rack on west side for washing trucks

## ELECTRICAL CONTRACTORS

New Challenge Creamery Buildings  
Berkeley, California

### CALIFORNIA ELECTRIC COMPANY

Industrial and Commercial Electric Construction

3015 ADELIN STREET, OAKLAND

## PLUMBING REFRIGERATION INDUSTRIAL PIPING

IN THE NEW PLANT OF  
CHALLENGE CREAM & BUTTER  
ASSOCIATION, BERKELEY,

Installed by



# E. C. BRAUN CO.

PLUMBING • HEATING • REFRIGERATION  
AIR CONDITIONING • INDUSTRIAL PIPING

2115 Fourth St., Berkeley

Phone BERkeley 7-2356

# A. I. A.

## American Institute



# ACTIVITIES

## of Architects

### Arizona Chapter:

James Macmillan, President; Arthur T. Brown, Secretary, 740 N. Country Club Road, Tucson, Arizona.

### Central Valley of California:

Herbert E. Goodpastor, President; Frank V. Mayo, Secretary, 307 Exchange Building, Stockton 2, California.

### Colorado Chapter:

Raymond H. Ervin, President; James M. Hunter, Secretary, 2049 Broadway, Boulder, Colorado.

### East Bay Chapter:

A. Lewis Koue, President; James H. Anderson, Vice-President; Loy Chamberlain, Secretary; Chester H. Treichel, Treasurer, Office, 3833 Piedmont Ave., Berkeley, California.

### Montana Chapter:

Ralph H. Cushing, President; H. C. Cheever, Secretary, Montana State College, Bozeman, Montana.

### Northern California Chapter:

Hervy P. Clark, President; Lester Hurd, Vice-President; Ralph Pollack, Secretary; William C. Ambrose, Treasurer; 605 Market Street, San Francisco.

### Oregon Chapter:

Walter E. Church, President; Frank Roehr, Secretary; Office 619 Builders Exchange Bldg., Portland 4, Oregon.

### San Diego Chapter:

H. Louis Bodmer, President; Louis J. Gill, Secretary, 203 Granger Building, San Diego, California.

### Santa Barbara Chapter (California):

Chester L. Carjola, President; Robert I. Hoyt, Secretary, 116 E. Sola St., Santa Barbara, California.

### CALIFORNIA COUNCIL OF ARCHITECTS

Vincent Palmer, President; Andrew Hass, Vice-President; A. C. Martin, Jr., Secretary-Treasurer; 369 Pine St., San Francisco 4.

### Southern California Chapter:

Adrian Wilson, President; A. C. Martin, Jr., Vice President; Walter L. Reichardt, Secretary; George E. Gable, Treasurer; Chapter Headquarters, 3757 Wilshire Blvd., Los Angeles 5, California.

### Spokane Chapter (Washington):

Noel E. Thomson, President; Kenneth D. Stormont, Secretary, Hutton Building, Spokane, Washington.

### Utah Chapter:

George Cannon Young, President; Theodore R. Pope, Secretary, 29 South State Street, Salt Lake City 1, Utah.

### Washington State Chapter:

Clifton J. Brady, President; Arriego M. Young, Vice-President; John Richards, 2nd Vice-President; Ralf E. Decker, Sec.; Waldo B. Christenson, Treasurer, Office 1411 Fourth Avenue Building, Seattle 1, Washington.

### Hawaii Chapter::

Kenneth W. Roehrig, President; James Morrison, Secretary, 334 Federal Bldg., Honolulu, T. H.

### NORTHERN CALIFORNIA CHAPTER

A. C. Horner of the National Lumber Manufacturers' Association, and T. K. May and W. J. Graham of the West Coast Lumbermen's Association, discussed and demonstrated "Lumber Grading" according to the latest revised Rule No. 14 of the West Coast Lumbermen's Association, at a meeting on November 17th.

\* \* \*

A talk and color slides on "Store Design," given at the California Council of Architects convention at Catalina in October, was presented to members November 18th at a meeting held at the St. Francis Yacht Club.

### CONSTRUCTION INDUSTRY ADVISORY COUNCIL

James D. Edmunds, Jr., of Baltimore, Md., has been elected chairman of the Construction Industry Council, according to an announcement from the Construction and Civic Development Department Committee of the Chamber of Commerce of the United States.

Edmunds is past president of the American Institute of Architects.

The Construction Industry Advisory Council comprises more than 100 national trade and professional organizations. It meets to consider broad problems of interest to the entire construction industry.

\* \* \*

### WASHINGTON STATE CHAPTER

"Modern Architecture for the Modern School"

was the subject of a lantern slide discussion at the regular November dinner and business meeting. The material was loaned for showing by the Museum of Modern Art of New York City.

# • There's a type to suit your needs



• for plants, schools and public buildings

You'll find just the type of drinking fountain appropriate to your design or purpose in the Halsey Taylor line! Smartly styled, recognized for health-safety advantages, trouble-proof, dependable, they are the choice of architects and building authorities the country over. Write for newest catalog, or see SWEETS.

THE HALSEY W. TAYLOR CO., WARREN, O.  
West Coast Plant REDLANDS, CALIF.

# Halsey-Taylor

## DRINKING FOUNTAINS



A-4

# WITH THE ENGINEERS

Structural Engineers Association of Northern California

William W. Moore, President; John A. Blume, Vice President; Franklin P. Ulrich, Treas.; G. A. Sedgwick Sec.; Wm. H. Popert, Consultant; Office, Room 712, 57 Post St., San Francisco, Phone SUtter 1-5474. DIRECTORS, Mark Falk, M. V. Pregnoff, and R. D. Dewell.

American Society of Civil Engineers San Francisco Section

Sidney T. Harding, President; Lawrence A. Elsener, Vice President; John E. Rinne, Secretary-Treasurer, 225 Bush Street, San Francisco 20.

Puget Sound Engineering Council (Washington)

R. E. Kister, A. I. E. E., Chairman; E. R. McMillan, A. S. C. E., Vice Chairman; L. B. Cooper, A. S. M. E., Secretary; A. E. Nicholson, I. E. S., Treasurer; Offices, L. B. Cooper, c/o University of Washington, Seattle 5, Washington.

## STRUCTURAL ENGINEERS ASSOCIATION OF NORTHERN CALIFORNIA

Col. Lyle Rosenberg, U. S. A. Engineers, Retired, spoke at the November 4th meeting on "PLANNING AND CONSTRUCTION AT OKINAWA," giving many interesting details and sidelights of activities on the Pacific island.

\* \* \*

JOHN A. BLUME was a panel speaker at the recent CONSTRUCTION INDUSTRY CONFERENCE in San Francisco.

**FOR BETTER SERVICE**  
*Remember that*  
**KRAFTILE is**  
**WESTERN HEADQUARTERS**  
**FOR**

- |                                 |  |
|---------------------------------|--|
| ▶ GLAZED Structural Wall Units  | ▶ ACID Brick                             |
| ▶ PATIO Tile                    | ▶ ACID-PROOF Jointing Compounds          |
| ▶ QUARRY Tile                   | ▶ ACID-PROOF Floor and Tank Construction |
| ▶ SWIMMING POOL Overflow Gutter | ▶ ACID-PROOF Coatings                    |



▶ QUONSET Packaged Steel Buildings

▶ STRAN-STEEL Framing

For complete information and prompt service, phone or write

**KRAFTILE COMPANY**

NILES, CALIFORNIA

NILES 3611

SAN FRANCISCO: 50 Hawthorne Street — DOuglas 3780

LOS ANGELES: 316 E. Commercial Street — MUtual 2411

CHARLES B. WILKIE, resident manager of Spencer & Morris, Inc., has moved to San Francisco, where offices are located at 580 Market.

\* \* \*

JAMES W. HERRON has moved to the Sharon Building, San Francisco.

\* \* \*

NEW MEMBERS include John P. Hopps, James E. Arnson, W. Caven Taylor, and John F. Meehan.

\* \* \*

## LIGHTING ENGINEERS SCHEDULE

### 1948 CONFERENCE FOR BOSTON

A. H. Manwaring, chairman of the Illuminating Engineering Society Conference Committee has announced that the Society's National Technical Conference for 1948 has been set for Boston, Massachusetts.

Technical papers on lighting, lamps and related subjects by experts from all parts of the United States and Canada are scheduled for consideration.

Dates have been set for September 20 to 24.

\* \* \*

JOHN A. BLUME has moved into larger offices at 45 Second Street, San Francisco.

\* \* \*

## SAN FRANCISCO MAYOR CALLS BRIDGE MEETING

Roger Lapham, Mayor of San Francisco, called a meeting of civic, professional, and governmental representatives in San Francisco early in December for the purpose of discussing a second bay crossing.

The State of California has approved the construction of a second bay bridge, however, some of the details as to the exact location of the approaches in San Francisco have met with a certain amount of opposition.

\* \* \*

F. G. ERIC PETERSON, Engineer, has been appointed a member of the City Planning Commission for the City of El Cerrito, California.

\* \* \*

## APPOINTED CONSULTING ENGINEER GOLDEN GATE BRIDGE

John G. Little, Superintendent, Bureau of Building Inspection, City and County of San Francisco, has been appointed consulting engineer for the Golden Gate Bridge and Highway District.

He succeeds the late L. H. Nishkian.

ARCHITECT AND ENGINEER

(From Page 16)

in many ways and over a wide range. It is apparent that to obtain a satisfactory solution to such a problem it is necessary to use a special approach since it is out of the question to attempt a complete analysis of all possible stresses and strains that may occur in all types of building when subjected to all possible earthquakes. The general problem reduces itself to two special problems. First, a study of strong motion earthquakes to determine what characteristics are common to all earthquakes and how these common characteristics can be utilized to predict the maximum stresses that may occur in structures. Second, a study of building types to evaluate the properties that influence the dynamic behavior during an earthquake.

The study of strong-motion earthquakes is based upon the earthquake accelerograms recorded by the U. S. Coast and Geodetic Survey. One feature of this phase of research is the processing of the accelerograms by a mechanical analyzer. Without going into the mathematical details of the problem it can be stated that by an application of mathematical statistics it has been shown that the strong motion earthquakes which have been recorded have a common characteristic which is essentially of a "random" nature.

The most interesting feature of this is that the maximum energy pumped into a structure by the ground motion is essentially independent of the period of vibration. Essentially independent means that when the maximum energy is plotted for periods of vibration ranging from two tenths of a second to three seconds there is obtained an irregular line whose segmental average height is approximately the same over the complete range. The local irregularities in the line are rather sharp so that two structures of very closely the same period of vibration may attain markedly different maximum energies despite the fact that "on the average" the short period, medium period and long period structures pick up approximately the same maximum energies. This explains the rather surprising instances where it has been observed that two very similar structures, located near each other, received quite different amounts of damage during an earthquake. This characteristic of strong motion earthquakes can be explained by stating that the ground waves during a strong motion earthquake are not spaced uniformly in time so that they are not in resonance with the vibration of a structure. Actually the time of arrival of the waves is such that their effects tend to cancel and

(See Next Page)

**NEW!**★ *Venetian Blinds***BUILT WITH****REMOVABLE SLATS**

Here's the greatest  
Blind improvement of 50 years  
**AMBASSADOR VENETIANS with**  
**REMOVABLE SLATS**

Just unsnap the fasteners (there's only one to each slat) and slip the slats out. Clean them . . . it's as easy as washing dishes, then put them back. It couldn't be simpler. • These revolutionary Ambassador Venetians are ideal for use in all

**Offices**  
**Apartments**  
**Hotels, Hospitals**  
**Public Buildings**  
**Factories**

May we show you how much better they are, how much tighter they close, and how little they cost?

**GUNN, CARLE & Co.**

20 POTRERO AVE. • SAN FRANCISCO 3

UNderhill 1-5480

(From Preceding Page)

the maximum energy pumped into a structure is only a small percentage of that which would be obtained if resonance did occur. Of course, the cancelling is not complete and that energy which is picked up by a structure corresponds to random times of arrival of the ground waves. The random time of arrival is the reason that short period and long period structures have the same energy response and is also the reason that two structures with almost the same period may have markedly different responses. These characteristics of earthquakes permit certain important generalizations to be made concerning the effect of earthquakes upon structures. These studies of earthquake records have also developed a method of measuring earthquake intensities, in an engineering sense, which with the accumulation of more data should give a very satisfactory statistical description of strong motion earthquake intensities.

The study of the behavior of structures during earthquakes is intended to answer the following questions: Knowing the characteristics of earthquakes, what maximum stresses will be induced in a structure with specified properties? The chief difficulty in this line of approach is the determination of the properties of actual structures. It appears that the characteristics of the ground upon which the foundation of the structure rests may have an important influence upon the dynamic behavior of the structure, and it also appears that the internal dissipation of energy within the structure during an earthquake has an important affect upon the stresses developed. The dynamic properties of soils and the energy dissipation within structures are items about which relatively little is known and considerable investigation is necessary before a satisfactory state of knowledge is attained. There are, of course, other unknown factors in addition to those which have been mentioned. It may be pointed out that the desirability of using seismic factors that vary along the height of the building was established by this phase of research.

There is little doubt but that if the significant properties of structures and foundation materials can be catalogued and if the significant characteristics of strong motion earthquakes are known then rational rules for the design of structures can be laid down. Of course, a very considerable amount of research is necessary before it is possible to lay down definitive rules. So far satisfactory progress has been made in the study of engineering seismology and it is unfortunate that the information has not been disseminated among

## Is Each Home You Plan a "GOOD RISK"?

Banks and other home financing institutions, experienced in home construction values, agree that a poorly wired home is not as good a "risk" as one with adequate wiring.

Homes, new or remodeled, which lack a sufficient number of circuits and convenience outlets, or which utilize wire of insufficient size, are handicapped for loan or resale purposes . . . and also fail to provide the efficient electrical service the modern family requires.

Make sure the homes you plan give your clients maximum value . . . financially and in the comforts and conveniences of electrical living . . . by specifying certified Adequate Wiring.

Your local utility office will be glad to assist, without cost or obligation in the preparation of wiring layouts.

### NORTHERN CALIFORNIA ELECTRICAL BUREAU

1355 Market Street

San Francisco 3

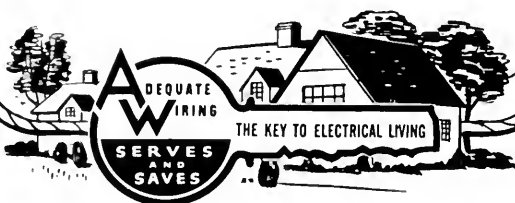

all interested parties. The interruption caused by the war can perhaps be blamed in large part for the failure to make the greatest possible use of existing knowledge in engineering seismology. In this postwar period the renewed interest of engineers and seismologists should give an impetus to the work being done in engineering seismology that will lead to important advances.

---

### LOS ANGELES CIVIL SERVICE

The Los Angeles Civil Service Commission has openings for permanent positions as Building Specification Writers in the Los Angeles County Mechanical Department.

Persons with at least 3 years recent experience writing building specifications in architectural offices, are desired. Salary ranges from \$395 to \$440 per month.

---

### COLOR STYLING

The Glidden Company, nationally known paint manufacturers, is offering a free service in color styling to architects, engineers and contractors, through its color expert, Carl Smedley, whose reputation in this specialized field is outstanding.

All that is necessary is for the architect or engineer to supply the Glidden Company with a set of blue prints indicating the type of building planned and from these prints Mr. Smedley will work out a complete decorative scheme for both the exterior and interior of the building.

---

### EMERGENCY COMMITTEE PROGRAM FOR COMMUNITY DISASTER RELIEF

(From Page 17)

structural engineers in this undertaking. It was also taken up with the San Francisco Bay Area Health and Safety Officials who also desire to cooperate.

It is hoped that these little community committees composed of the building inspector and the structural engineer, will be joined by an architect and possibly a mechanical engineer, an electrical engineer and a builder, etc., to form a disaster relief committee for the building industry in each community.

The principal purpose of this committee will be that the building inspector's office will always be kept in contact with available technicians in the building business for disaster relief purposes.

## How to keep your buildings young



### Plan for built-in telephone outlets now

Even though only one telephone is needed initially, plan others for your client's future convenience.



Specify that telephone conduit be installed during construction. It adds little to building costs . . . adds real value to the house.

Additional telephones may be added without drilling through the flooring or running wires along the baseboards.

And the convenience of well-placed telephone outlets will be appreciated year after year.



Call or dial your local Telephone Business Office. Ask for Architects and Builders Service.

### The Pacific Telephone and Telegraph Co.



## HEADLINE NEWS AND VIEWS

By E. H. W.

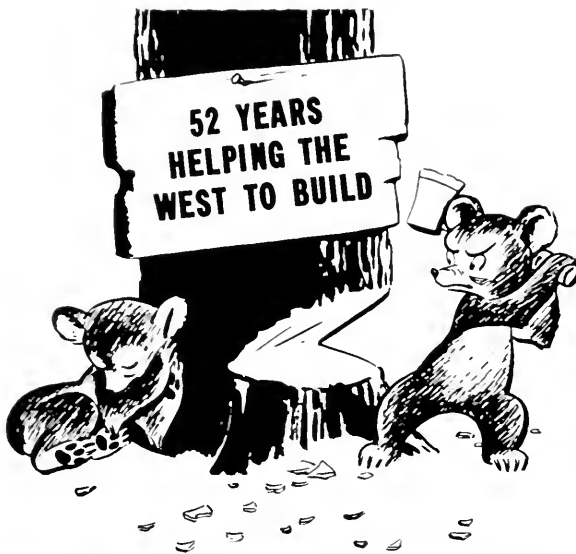

### E. K. WOOD LUMBER CO.

**SAN FRANCISCO** General Offices: No. 1 Drumm Street  
**LOS ANGELES** Office and Yards: 4710 S. Alameda St. — JE 3111  
**OAKLAND** Yards and Wharves: 2111 Frederick St. — KE 24277  
**PORTLAND** Mill Sales Office: 827 Terminal Sales Bldg.  
**SAW MILLS:** Roseburg, Oregon • Reedsport, Oregon  
**RETAIL YARDS:** LOS ANGELES • OAKLAND • ONTARIO • HOLLYWOOD  
 LONG BEACH • RIVERSIDE • TEMPLE CITY • SIERRA MADRE • INDIO • THERMAL  
 LA VERNE • WHITTIER • PASADENA • SAN PEDRO

"The greatest contribution which the Federal government can make in the field of housing and construction is to help the building industry speed up the adoption of modular coordination and the principles of the Industry Engineered Housing Program";—Tyler S. Rogers, president Producers' Council.

Marking San Francisco Airport's transition into an international air terminal. Dedication ceremonies were recently held with civic, business and military leaders attending. An additional \$20,000,000 is expected to be spent on further improvements.

The School of Management, Golden Gate College, San Francisco, is conducting an Institute on "Home Building Today and Tomorrow," for contractors, developers, materials and equipment producers and distributors, home furnishers, and home loan executives . . . Everybody seems to be in the picture except The ARCHITECT.

Industrial Development in northern California during the month of September accounted for 49 projects at a cost of \$12,834,500:—Industrial Department, San Francisco Chamber of Commerce.

"There is plenty of work ahead of the construction industry with an estimated need for new construction approaching \$21,000,000,000 in 1950":—James W. Follin, Ass't. Adm. Federal Works Agency.

"What the Government aids, it will also control",—Frank P. Foisie President, Waterfront Employers of the Pacific Coast.

"No Art is more widely misunderstood than the art of architecture,"—Joseph Hudnut, Dean, Graduate School of Design, Harvard University.

A proposed Simplified Practice Recommendation for Welded Wire Fabric Reinforcement for Concrete Pipe has been submitted to producers, distributors and uses for approval, and comment by the Commodity Standards Division, National Bureau of Standards.

A very simple solution to the G. I. Housing problem is to divert our Federal tax funds from Europe to America—Just think, what could be done for the U. S. Veteran with the funds being tossed overseas!

# CZC

**PRESSURE TREATED LUMBER**  
**● PROTECTS AGAINST DECAY**  
**AND TERMITE ATTACK**

*Specify it in your home*  
*Available through Lumber Dealers*

<b>LOS ANGELES</b> 601 W. 5th Street Phone Mlchigan 6294	<b>SAN FRANCISCO</b> 333 Montgomery Street Phone DOuglas 2-3883
--	---

## J. H. Baxter & Co.

AGENTS FOR WEST COAST WOOD PRESERVING CO. SEATTLE, WASH



## IN THE NEWS

### HOME SHOW

The San Francisco Real Estate Board and the Associated Home Builders of San Francisco, Inc., will sponsor a National Home Show in the San Francisco Civic Auditorium on April 7-14, 1948.

**COUNTY HOSPITAL ADDITION,** Reno, Nevada. The Walker Bowdin Construction Co., Reno, have been awarded contract for construction of a laundry and boiler room addition to the County Hospital at a cost of \$347,790. Douglas D. Stone & Lou Mulloy, San Francisco, and DeLongchamps & O'Brien, Reno, are the architects.

### SEWAGE BONDS VOTED

Voters of Hayward, California, recently approved a \$1,840,000 bond issue for the construction of a new sewage disposal plant. Construction to be of reinforced concrete.

C. S. CONRAD has been appointed General Manager of Sales for the Columbia Steel Company, according to a recent announcement. Other executive Sales appointments includes W. B. Sawyer, Jr., Assistant General Manager of Sales-administration; Eric Barnett, Assistant general manager of soles-distribution; and C. L. Hamman, General Sales Staff Manager.

### SCHOOL BONDS VOTED

A F.W.A. grant of \$13,615 for plans and bonds have been voted for the construction of a 6-classroom, shop building and cafeteria and home making department high school at Elk Grove, California. Cost of the building will exceed \$245,000 according to Harold H. Weeks, Architect of San Francisco.

**GRAMMAR SCHOOL ADDITION.** The Alta Construction, San Francisco, have been awarded a \$381,494 contract for construction of an addition, shop building, community building, and swimming pool for the Lakeside Union School District, near Bakersfield, California.

## Planned Lighting with **ZENITH**

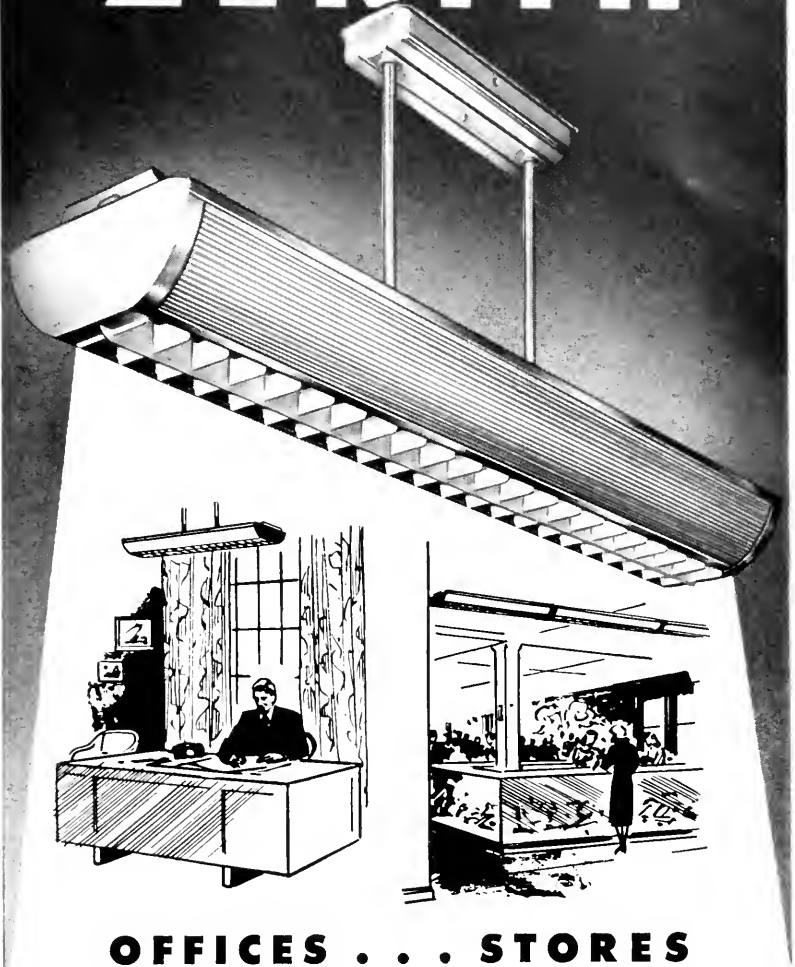

## OFFICES . . . STORES

Here's a commercial fluorescent luminaire that's engineered for superlative lighting performance — yet costs only a very little more than conventional equipment. Precision formed on precision tools, the Zenith installs easily, services quickly. Polystyrene plastic side panels are light, strong and shatterproof. The shielding unit controls the light for greatest effectiveness, with a minimum of surface brightness. The Zenith may be installed individually as shown, or in continuous mounting.

*Write for the new Zenith catalog sheet*



**FOR THE BEST IN INDOOR AND OUTDOOR LIGHTING IT'S SMOOT-HOLMAN**

# LANDSCAPE ARCHITECTURE

## Notes of The Profession

ASSOCIATION OF LANDSCAPE ARCHITECTS, SAN FRANCISCO REGION

Vernon Dean, President; Robert Royston, Vice-President; Ned Rucker, Treasurer;  
E. L. Anderson, Secretary, 1736 Franklin, Oakland, California.

### ASSOCIATION OF LANDSCAPE ARCHITECTS SAN FRANCISCO REGION

The Association has scheduled its regular annual Christmas Party at the Claremont Hotel in Berkeley, at a date yet to be determined by the Executive Board. It is expected that in addition to the members of the Association, and their individual guests, that there will be several officers and members of the newly organized East-Bay Chapter of the A.I.A. present.

Invitations are being sent thru the office of E. L. Anderson, Secretary of the Association.

Governor Earl Warren has requested that the Association of Landscape Architects, San Francisco Region, recommend men for appointment to the Physical Advisory Planning Board, the appointments to which will be announced in the near future. The Association recommended four men to the Governor, but the names of those men will not be published until after Governor Warren has made his selection.

The Association wishes to welcome the new California Association of Landscape Architects, Los Angeles, into the fold of organized Landscape Architects. This new group was organized after the pattern set by the Association of Landscape Architects, San Francisco Region. We have also received word that another new organization has been formed following our pattern in Omaha, Nebraska, and is called the Association of Landscape Architects, Omaha Region. Welcome to that group also.

On October 9, 1947, the East-Bay Chapter of the A.I.A. held its Charter meeting at the Claremont Hotel, Berkeley. The Association was represented at this meeting by Ned S. Rucker, Bernard Wiseltier, E. L. Anderson, and Harry W. Shepherd. Members attending the meeting were very much pleased by the fine reception their attendance received from the Architects, and all members of the Association appreciate the fact.

HOWARD GILKEY, Designer of the Oakland Spring Garden Show, has just returned from a

trip to Mexico. He says the trip, sponsored by the Oakland Chamber of Commerce, was very fabulous with State banquets, brass bands, and all the trimmings in their honor. Gilkey reports a big building boom underway in Mexico with designing of buildings being done in modern style but without neglect of the Mexican tradition. Among interesting experiences was the honor of being the first group to travel on the first paved road in the city of Guanojuato.

\* \* \*

RALPH JONES, City Landscape Architect, City of Alameda, reports the Alameda Planning Commission met recently and approved plans for the construction of the Longfellow Park which were designed and drawn by Ralph. The plans call for the complete remodeling of the existing Park and clubhouse.

\* \* \*

DOROTHY CRAWFORD, now with the Oakland Planning Commission as Planning Engineer, a position she has held for the past four months. Dorothy recently designed and drew the site plans for the five Municipal swimming pools about to be constructed in Oakland. All five of her site plans have been approved by the Oakland Planning Commission.

\* \* \*

ROBERT N. ROYSTON. The University of California recently announced that Robert N. Royston has been appointed as an Assistant Professor in the Division of Landscape Design.

\* \* \*

STUDENT MEMBERS A.L.A. A greater interest in the activities of the professional designers by student members of the A.L.A. was evidenced at the recent General meeting of the Association on October 24, 1947. Besides attending the general meetings, the Junior members are serving on many committees in the A.L.A.

\* \* \*

PRENTISS FRENCH, vice president of Western Engineers, Inc., reports this company is working on the design of a new run-way for light private planes at Buchanan Field, Concord, California. The work is being done for the Contra Costa County Board of Supervisors. Western Engineers,

Inc., of which Rex A. Daddisman is president, have completed a master plan for the ultimate development of this airfield, with construction to be completed in the Spring. The firm have another project in the planning stage, an air field at Placerville, California, which is being sponsored jointly by the city of Placerville and the U. S. Forest Service, together with local city and county interests.

\* \* \*

DOUGLAS BAYLISS is doing the landscaping on the building for the new headquarters of the American Red Cross in San Francisco.

\* \* \*

JACK GIBSON of the Landscape Architectural firm of OSMUNDOSN, STALEY & GIBSON, reports his firm is completing work on the Severson Estate in Atherton, California, and a number of small places where they have emphasized the use of new materials and new combinations of the old. Along this line he has designed and has on display in Menlo Park, California, a new line of garden furniture, pergolas, pools and fountains, showing a combination of copper, brass, and wrought iron along contemporary lines.

\* \* \*

WILLA CLOYS CARMACK of San Carlos, California, is busy with a number of interesting gardens in Atherton, Belmont, Redwood City, Los Altos and Hillsborough.

\* \* \*

T. J. KENT, JR., Director of Planning for San Francisco, spoke at a recent meeting of the Association on the activities of the San Francisco Planning Commission which may generally be broken down into three categories:

1. Land use and the new zoning ordinance.
2. Urban redevelopment.
3. Transportation.

Much to everyone's satisfaction he emphasized the transportation phase, and in particular the all important question of the second bay crossing.

He stressed the fact that the main problem we face is not that of a second bay crossing for automobiles, but of a regional mass transit system. Effective circulation in a metropolitan area can be achieved only by provision and full utilization of efficient mass transit facilities.

\* \* \*

#### LANDSCAPE ARCHITECTS WITH THE SAN FRANCISCO PLANNING COMMISSION

Hired as a consultant to work with the San Francisco Planning Commission staff on the redevelopment studies of the Western Addition under the California Community Redevelopment Act, is a member of the Association of Landscape Architects, San Francisco Region, Mel Scott.

Other member Landscape Architects of the Asso-

ciation employed as staff members are: Frank Lombardi, Samuel Jung, Ruth Jaffe, Edna Horn, and Bill Spangler. (Everybody was happy to hear of Bill's recent marriage to Frances Yeazell—October 31st.)

#### MARIN COUNTY LANDSCAPE ARCHITECTS

Officials of the Marin Art & Garden Show have announced that the 1948 event will be held early in June, rather than in September as heretofore.

Larger prizes will be offered and every effort made to provide for the increasing participation and public interest in the Show.

\* \* \*

Marin County Planning Commission Conservation League directors Helen Van Pelt and Prentiss French are working on the acquisition of Tomales Bay beaches, and the road to the top of Mt. Tamalpais, as a part of the California State Park System.

\* \* \*

KATY & PAUL STEINMETZ are moving their offices to Redhill Boulevard in San Anselmo.

#### LANDSCAPING BEGINS ON U. C. L. A. GARDENS

Two 300-foot quadrangles, soon to become the heart of the greatly enlarged U. C. L. A. campus of the future, are being laid out on the filled in land on either side of what used to be the bridge.

Rubber trees, lawn, a sprinkling system and four temporary walks are now being installed. Later shrubs, flowers and additional walks will be added to make two formal gardens, which will eventually be flanked by campus buildings.

STORE CONTRACT AWARDED to Pacific Builders, Salinas, for construction of a \$200,000 store building at Salinas for the J. C. Penney Company. Harold S. Johnson, Los Angeles, is the Architect; W. D. Peugh, San Francisco, is supervising architect.

## LINOLEUM

Armstrong, Nairne, Pabco, Sloane-Blabon

**Linoleum, Asphalt and Rubber Tile  
for any installation**



### FOX TILE CO.

3247 E. 14th Street, Oakland  
Phone:: ANdover 1-0431

# STRUCTURAL STEEL

For Class A Buildings,  
Bridges, etc.

## JUDSON PACIFIC - MURPHY CORP.

4300 EASTSHORE HIGHWAY  
EMERYVILLE, CALIF.

## FORDERER CORNICE WORKS

*Manufacturers of*

Hollow Metal Products • Interior Metal Trim  
Elevator Fronts and Cabs  
Metal Plaster Accessories • Sanitary Metal Base  
Flat and Roll Metal Screens  
Metal Cabinets • Commercial Refrigerators

269 POTRERO AVE.

SAN FRANCISCO, CALIF. HEMLOCK 4100

## VALUABLE NEWS SERVICE

- BUILDING MATERIAL DEALERS
- CONTRACTORS
- ENGINEERS
- FINANCIAL INSTITUTIONS

**ARCHITECTS REPORTS** gives advance news on construction projects in Northern California, lists: name of projects, location, architect, proposed cost and other pertinent information.

**HANDY** individual slip-reports, issued daily at a total cost of only  
\$10 a month

## ARCHITECT'S REPORTS

Published Daily

The ARCHITECT and ENGINEER, Inc.

68 Post Street, San Francisco - DO 8311

## EXHIBIT BUILDING LIVESTOCK BARN

A contract has been awarded Willis F. Lynn for construction of a structural steel frame and concrete block exhibit building and livestock barns at the Alameda County Fair Grounds, Pleasanton.

Kent & Hass, San Francisco, are the architects.  
Cost of the construction is estimated at \$215,850.

**HANGAR BUILDING** at Merced (California) City Airport has been awarded to Graham & Jensen, Contractors, Merced.

**AWARDED SEWAGE CONTRACT:** The Hoagland Findlay Engineering Company of Long Beach, California, have been awarded a \$192,970 contract for the construction of a sewage disposal plant at Tracy, California.

C. A. WILLSON has been appointed Research Engineer of the Committee on Reinforced Concrete Research, American Iron & Steel Institute, New York, succeeding Roy Zipprodt, deceased.

## GRACE BROS.—SANTA ROSA

The Litchfield Construction Company of San Rafael, California, have been awarded a \$124,324 contract for the construction of a new bottling plant for the Grace Bro's. Brewery at Santa Rosa, California.

According to J. Clarence Felciano, Architect, Santa Rosa, the new building will be of one story reinforced concrete, with acid proof tile floors, and vitrolite front.

**GENERAL JONATHON M. WAINWRIGHT** has been named vice-president in charge of public relations for the ACME SASH BALANCE COMPANY of Los Angeles.

**LITHOGRAPH PLANT CONTRACT:** Theo G. Meyer, Quint & Custer of San Francisco have been awarded a \$555,904 contract for the construction of a new lithographing plant for A. Carlisle Co., San Francisco.

**CLINTON CONSTRUCTION COMPANY,** San Francisco, have a contract for remodeling the American Weekly printing plant, San Francisco, at \$300,000.

## SEEKS LITERATURE

The Building Utilities Unit Company, 666 Mission Street, San Francisco, is seeking literature from manufacturers and distributors on products covering all phases of the construction industry for its files.

# ESTIMATOR'S GUIDE

## BUILDING AND CONSTRUCTION MATERIALS

PRICES GIVEN ARE FIGURING PRICES AND ARE MADE UP FROM AVERAGE QUOTATIONS FURNISHED BY MATERIAL HOUSES TO SAN FRANCISCO CONTRACTORS. 2½% SALES TAX ON ALL MATERIALS BUT NOT LABOR

All prices and wages quoted are for San Francisco and the Bay District. There may be slight fluctuation of prices in the interior and southern part of the state. Freight cartage, at least, must be added in figuring country work.

**BONDS**—Performance—\$10 per \$1000 of contract. Labor and materials, \$10 per \$1000 of contract.

**BRICKWORK**—

- Common Brick—Per 1M laid—\$100.00 to \$120.00 (according to class of work).
- Face Brick—Per 1M laid—\$215 to \$250 (according to class of work).
- Brick Steps—\$3.50 per lin. ft.
- Brick Veneer on Frame Bldg.—Approx. \$2.25 per sq. ft.
- Common Brick—\$28.50 per M, truckload lots, f.o.b. job.
- Face Brick—\$75 to \$90 per M, truckload lots, delivered.
- Cartage—Approx. \$9.00 per M.

**BUILDING PAPER**—

1 ply per 1000 ft. roll.....	\$5.30
2 ply per 1000 ft. roll.....	7.80
3 ply per 1000 ft. roll.....	9.70
Brownskin, Standard, 500 ft. roll.....	8.00

**BUILDING HARDWARE**—

- Sash cord com. No. 7.....\$2.65 per 100 ft.
- Sash cord com. No. 8.....3.00 per 100 ft.
- Sash cord spot No. 7.....3.65 per 100 ft.
- Sash cord spot No. 8.....4.00 per 100 ft.
- Sash weights, cast iron, \$100.00 ton.
- Nails, \$5.50 base.

**CONCRETE AGGREGATES**—

The following prices net to Contractors unless otherwise shown. Carload lots only.

	Bunker per ton	Del'd per ton
Gravel, all sizes .....	\$2.44	\$2.75
Top Sand .....	2.38	3.13
Concrete Mix .....	2.38	3.06
Crushed Rock, ¼" to ¾".....	2.38	2.94

	Bunker per ton	Del'd per ton
Crushed Rock, ¾" to 1½".....	\$2.38	\$3.13
Roofing Gravel .....	2.81	3.50
River Sand .....	2.50	3.06

**Sand**—

Lapis (Nos. 2 & 4).....	3.56	3.94
Olympia (Nos. 1 & 2).....	3.56	3.88

**Cement**—  
Common (all brands, paper sacks), carload lots, \$3.02 per bbl. f.o.b. car; delivered \$3.60. Cash discount on carload lots, 10c a bbl., 10th Prox., less than carload lots \$4.00 per bbl. f.o.b. warehouse or delivered. Cash discount 2% on L.C.L.

Trinity White	} 1 to 100 sacks, \$3.13 sack warehouse or del.; \$9.56 bbl. carload lots.
Medusa White	

**DAMP-PROOFING and Waterproofing**—

- Two-coat work, \$8.00 per square.
- Membrane waterproofing—4 layers of saturated felt, \$9.00 per square.
- Hot coating work, \$5.00 per square.
- Medusa Waterproofing, \$3.50 per lb. San Francisco Warehouse.
- Tricocel waterproofing.
- (See representative.)

**ELECTRIC WIRING**—\$15 to \$20 per outlet for conduit work (including switches).

Knob and tube average \$6.00 per outlet. (Available only for priority work.)

**ELEVATORS**—

Prices vary according to capacity, speed and type. Consult elevator companies. Average cost of installing a slow speed automatic passenger elevator in small four story apartment building, including entrance doors, about \$8000.00.

**EXCAVATION**—

- Sand, \$1.00; clay or shale, \$1.50 per yard.
- Trucks, \$30 to \$45 per day.
- Above figures are an average without water. Steam shovel work in large quantities, less; hard material, such as rock, will run considerably more.

**FIRE ESCAPES**—

Ten-foot galvanized iron balcony, with stairs, \$250 installed on new buildings; \$300 on old buildings.

**FLOORS**—

- Composition Floors, such as Magnesite, 50c per square foot.
- Linoflor—2 gages—\$3.00 per sq. yd.
- Mastipave—\$1.50 per sq. yd.
- Battleship Linoleum—available to Army and Navy only—1/8" —\$3.50 sq. yd. 3/16" —\$3.50 sq. yd.
- Terazzo Floors—\$1.50 per sq. ft.
- Terazzo Steps—\$2.50 per lin. ft.
- Mastic Wear Coat—according to type—20c to 35c.

**Hardwood Flooring**—

- Standard Mill grades not available.
- Victory Oak—T & G
- 3/4" x 2 1/4".....\$252.00 per M. plus Cartage
- 1/2" x 2".....210.00
- 1/2" x 1 1/2".....200.00
- Prefinished Standard & Better Oak Flooring
- 3/4" x 3 1/4".....\$265.00 per M. plus Cartage
- 1/2" x 2 1/2".....237.00 per M. plus Cartage
- Maple Flooring
- 3/4" T & G Clear \$330.00 per M. plus Ctg.
- 2nd 305.00 per M. plus Ctg.
- 3rd 255.00 per M. plus Ctg.
- Floor Layers' Wage, \$2.12½ per hr. (Legal as of July 1, 1947. Given us by Inlaid Floor Co.)

**GLASS**—

- Single Strength Window Glass.....\$ .40 per □ ft.
- Double Strength Window Glass......60 per □ ft.
- Plate Glass, under 75 sq. ft.....1.50 per □ ft.
- Polished Wire Plate Glass.....2.25 per □ ft.
- Rgh. Wire Glass......60 per □ ft.
- Obscure Glass......40 per □ ft.
- Glazing of above is additional.
- Glass Blocks.....\$2.75 per □ ft. set in place

**HEATING**—

- Average, \$2.50 to \$3.00 per sq. ft. of radiation, according to conditions.
- Warm air (gravity) average \$64 per register.
- Forced air average \$91 per register.

**INSULATION AND WALLBOARD—**

Rockwool Insulation— (2")	\$65.00 per M sq. ft.
Cotton Insulation—Full-thickness (3 3/4")	\$95.50 per M sq. ft.
Aluminum Insulation—Foil-mounted on both sides	\$33.50 per M sq. ft.
Tileboard—4'x6' panel	\$9.00 per panel
Wallboard—1/2" thickness	\$55.00 per M sq. ft.
Finished Plank	\$69.00 per M sq. ft.
Ceiling Tileboard	\$69.00 per M sq. ft.

**IRON**—Cost of ornamental iron, cast iron, etc., depends on designs.

**LUMBER—**

No. 1 Common	\$90.00 per M
No. 2 Common	88.00 per M
Select O. P. Common	94.00 per M

**Flooring—**

	Per M Delvd.
V.G.-D.F. 8 & 8tr, 1 x 4 T & G Flooring	\$170.00
"C" and better—all	170.00
"D" and better—all	170.00
Rwd. Rustic—"A" grade, medium dry	150.00
8 to 24 ft.	
"B" grade, medium dry	150.00
Plywood	.15c to 18c per ft.
Plyscord	9/2c per ft.
Plywall	.9c per ft.
Plyform	.15c per ft.

**Shingles (Rwd. not available)—**

Red Cedar No. 1—\$13.00 per square; No. 2, \$10.50; No. 3, \$9.00.  
Average cost to lay shingles, \$6.00 per square.  
Cedar Shakes—Tapered: 1/2" to 3/4" x 25"—\$17.00 per square.  
Resawn: 3/4" to 1 1/4" x 25"—\$22.00 per square  
Average cost to lay shakes,—8.00 per square

**MILLWORK—Standard.**

D. F. \$150 per 1000. R. W. Rustic \$175 per 1000 (delivered).  
Double hung box window frames, average with trim, \$12.50 and up, each.  
Complete door unit, \$15 to \$25.  
Screen doors, \$6.00 to \$8.00 each.  
Patent screen windows, \$1.25 a sq. ft.  
Cases for kitchen pantries seven ft. high, per lineal ft., \$12.00 each.  
Dining room cases, \$15.00 per lineal foot.  
Rough and finish about \$1.00 per sq. ft.  
Labor—Rough carpentry, warehouse heavy framing (average), \$65.00 per M.  
For smaller work average, \$75.00 to \$85.00 per 1000.

**MARBLE—(See Dealers)**

**PAINTING—**

Two-coat work .....per yard 75c  
Three-coat work .....per yard \$1.00  
Cold water painting .....per yard 25c  
Whitewashing .....per yard 15c  
Turpentine.....\$1.85 per gal. in 5-gal. cont.  
Raw Linseed  
Oil.....\$3.33 per gal. in 5-gal. cont.

**Boiled Linseed**

Oil.....	\$3.23 per gal. in drums.
Boiled Linseed Oil—	\$3.33 per gal. in 5-gal. containers.
Replacement Oil—	\$2.75 per gal. in drums.
	\$2.75 per gal. in 5-gal. containers.
Use Replacement Oil.....	\$3.00 per gal. in 1 gal. cont.
A deposit of \$7.50 required on all drums.	

**PATENT CHIMNEYS—**

6-inch	\$2.00 lineal foot
8-inch	2.50 lineal foot
10-inch	3.50 lineal foot
12-inch	4.50 lineal foot

**PLASTER—**

Neat wall, per ton delivered in S. F. in paper bags, \$17.60.

**PLASTERING (Interior)—**

3 Coats, metal lath and plaster	Yard \$3.00
Keene cement on metal lath	3.50
Ceilings with 3/4 hot roll channels metal lath (lathed only)	3.00
Seilings with 3/4 hot roll channels metal lath plastered	4.50
Single partition 3/4 channel lath 1 side (lath only)	3.00
Single partition 3/4 channel lath 2 inches thick plastered	8.00
4-inch double partition 3/4 channel lath 2 sides (lath only)	5.75
4-inch double partition 3/4 channel lath 2 sides plastered	8.75
Thermax single partition; 1" channels; 2 1/4" overall partition width. Plastered both sides	7.50
Thermax double partition; 1" channels; 4 3/4" overall partition width. Plastered both sides	11.00
3 Coats over 1" Thermax nailed to one side wood studs or joists	4.50
3 Coats over 1" Thermax suspended to one side wood studs with spring sound isolation clip	5.00
Note—Channel lath controlled by limitation orders.	

**PLASTERING (Exterior)—**

2 coats cement finish, brick or concrete wall	Yard \$2.50
3 coats cement finish, No. 18 gauge wire mesh	3.50
Lime—\$4.00 per bbl. at yard.	
Processed LLime—\$4.15 per bbl. at yard.	
Rock or Grip Lath—3/8"—30c per sq. yd.	
1/4"—29c per sq. yd.	
Composition Stucco—\$4.00 sq. yard (applied).	

**PLUMBING—**

From \$150.00 per fixture up, according to grade, quality and runs.

**ROOFING—**

"Standard" tar and gravel, 4 ply—\$11.00 per sq. for 30 sqs. or over.  
Less than 30 sqs. \$14.00 per sq.  
Tile \$40.00 to \$50.00 per square.  
Redwood Shingles, \$15.00 per square in place.  
5/2 #1-16" Cedar Shingles, 4 1/2"  
Exposure .....\$16.50 square

5/8 x 16"—#1 Cedar Shingles, 5"  
Exposure .....\$17.00 square  
4/2 #1-24" Royal Shingles, 7 1/2"  
Exposure .....\$18.25 square  
Re-coat with Gravel \$5.50 per sq.  
Asbestos Shingles \$30 to \$60 per sq. laid.  
1/2 x 25" Resawn Cedar Shakes,  
10" Exposure .....\$18.50  
3/4 x 25" Resawn Cedar Shakes,  
10" Exposure ..... 21.00  
1 x 25" Resawn Cedar Shakes,  
10" Exposure ..... 22.00  
Above prices are for shakes in place.

**SHEET METAL—**

Windows—Metal, \$2.50 a sq. ft.  
Fire doors (average), including hardware \$2.80 per sq. ft.

**SKYLIGHTS—(not glazed)**

Copper, \$1.25 sq. ft. (flat).  
Galvanized iron, 65c sq. ft. (flat).  
Vented hip skylights 90c sq. ft.

**STEEL—STRUCTURAL—**

\$220 per ton erected, when out of mill.  
\$270 per ton erected, when out of stock.

**STEEL REINFORCING—**

\$200.00 per ton, in place.

**STORE FRONTS (None available).**

**TILE—**

Ceramic Tile Floors—\$1.50 per sq. ft.  
Cove Base—\$1.25 per lin. ft.  
Glazed Tile Wainscot—\$1.50 per sq. ft.  
Asphalt Tile Floor 1/8" x 3/4"—\$.40 per sq. ft.  
Light shades slightly higher.  
Cork Tile—\$1.00 per sq. ft.  
Mosaic Floors—See dealers.  
Lino-Tile—\$1.00 per sq. ft.

**Wall Tile—**

Glazed Terra Cotta Wall Units (single faced) laid in place—approximate prices:  
2 x 6 x 12.....\$1.25 sq. ft.  
4 x 6 x 12..... 1.50 sq. ft.  
2 x 8 x 16..... 1.45 sq. ft.  
4 x 8 x 16..... 1.75 sq. ft.

**VENETIAN BLINDS—**

75c per square foot and up. Installation extra.

**WINDOWS—STEEL—**

60c per square foot, \$5 for ventilators.

ARCHITECT AND ENGINEER

# IN THE NEWS

## FENESTRA CONVENTION

More than 350 Fenestra representatives from all sections of the United States attended a national sales convention this month.

H. F. Wardwell, president of the Detroit Steel Products Company, reported the convention program included trips through the company's window and spring plants in Detroit and a cruise of the Great Lakes; tour of the Fenestra building panel and door plants in Buffalo, and discussions of standardization, product development, marketing and advertising.

## FULLER PAINT TECHNICIAN RETIRES

Walter D. Jones, veteran technical director of W. P. Fuller & Co., retired from active duty on November 1, 1947 after 40-years of service with the pioneer western paint, glass and wall paper firm.

During his long career with the Company, Jones has been active in both the sales and technical divisions of the paint business.

A. P. Pahl, formerly manager of the South San Francisco laboratories, succeeds Jones as technical director in charge of all Fuller laboratories.

**AUTO SALES & SERVICE:** The H. H. Larsen Company of San Francisco have been awarded a \$65,000 contract for construction of an auto sales and service building in Burlingame, California. Wm. H. Teepe & Otto Hinterman, San Mateo, are the architects.

## NEW NEVADA HOTEL

A contract has been awarded to the J. Watkins construction company of Reno, Nevada, for the construction of a new 42-room and 2-apartment hotel.

The two-story structure will also contain a casino, bar, and coffee shop. A swimming pool is included in the plans.

## BUILDING TRADES WAGE (JOB SITES) NORTHERN AND CENTRAL CALIFORNIA

ATTENTION: The following are the PREVAILING hourly rates of compensation as determined by the Wage Adjustment Board, or which have been determined by the United States Department of Labor—Revised to Nov. 1, 1947. Wage scales shown are those being paid and in effect mostly by agreement between employees and their union.

CRAFT	San Francisco	Alameda and Contra Costa	Merin	Vallejo	San Mateo	San Jose	Stockton	Sacramento	Fresno
	ASBESTOS WORKERS	1.90	1.75	1.75	1.75	1.75	1.75	1.75	1.75
BRICKLAYERS	2.25	2.05	2.05	2.05	2.05	2.05	1.75	2.05	2.00
BRICKLAYERS, HODCARRIERS	1.75	1.57½	1.57½	1.57½	1.57½	1.57½	1.47½	1.15	1.25
CARPENTERS	2.00	1.75	1.75	1.75	1.75	1.62½	1.50	1.50	1.50
CEMENT FINISHERS	2.02½	1.75	1.75	1.75	1.75	1.75	1.75	1.75	1.75
ELECTRICIANS	2.25	1.87½	1.87½	1.70	1.87½	1.87½	1.75	1.82½	1.75
ENGINEERS: MATERIAL HOIST	2.25	1.60	1.60	1.60	1.60	1.60	1.60	1.60	1.60
PILE DRIVER	2.25	2.00	2.00	2.00	2.00	2.00	2.00	2.00	2.00
STRUCTURAL STEEL	2.00	2.00	2.00	2.00	2.00	2.00	2.00	2.00	2.00
GLASS WORKERS	1.58½	1.58½	1.58½	1.58½	1.58½	1.21	1.40	1.37½	1.37½
IRONWORKERS: ORNAMENTAL	1.85	1.85	1.85	1.85	1.85	1.85	1.85	1.85	1.85
REINF. RODMEN	2.00	1.75	1.75	1.75	1.75	1.75	1.75	1.75	1.75
STRUCTURAL	2.00	2.00	2.00	2.00	2.00	2.00	2.00	2.00	2.00
LABORERS: BUILDING & CONCRETE	1.40	1.25	1.15	1.15	1.15	1.15	1.25	1.25	1.15
LATHERS	2.25	1.90	1.60	1.87½	1.75	2.00	1.87½	1.60	1.87½
MARBLE SETTERS	2.00	1.75	1.75	1.75	1.75	1.75	1.75	1.75	1.75
MOSAIC & TERRAZZO	2.15	1.75	1.75	1.75	1.75	1.75	1.60	1.60	1.12½
PAINTERS	2.00	1.75	1.75	1.64	1.75	1.75	1.60	1.60	1.50
PILEDRIVERS	2.02½	1.86	1.86	1.86	1.86	1.86	1.86	1.86	1.86
PLASTERERS	2.25	2.09	1.75	2.00	2.05	2.00	2.00	1.87½	1.87½
PLASTERERS' HODCARRIERS	2.00	1.75	1.75	1.75	1.75	1.75	1.65	1.65	1.40
PLUMBERS	2.25	1.87½	1.87½	1.87½	1.87½	1.87½	1.87½	1.87½	1.87½
ROOFERS	2.00	1.62½	1.50	1.62½	1.25	1.37½	1.50	1.50	1.50
SHEET METAL WORKERS	2.00	1.75	1.75	1.75	1.75	1.75	1.75	1.75	1.75
SPRINKLER FITTERS	1.75	1.58	1.58	1.58	1.58	1.58	1.58	1.58	1.58
STEAMFITTERS	2.25	1.87½	1.87½	1.87½	1.87½	1.87½	1.87½	1.87½	1.87½
STONESETTERS (MASON'S)	2.37½	2.05	2.05	2.05	2.05	2.05	1.75	2.05	2.00
TILESETTERS	2.15	1.75	1.75	1.75	1.75	1.75	1.37½	1.37½	1.37½

Prepared and compiled by

CENTRAL CALIFORNIA CHAPTER, ASSOCIATED GENERAL CONTRACTORS OF AMERICA

with the assistance and cooperation of secretaries of General Contractors Associations and Builders Exchanges of Northern California

# CLASSIFIED ADVERTISING

RATE: 10c PER WORD . . . CASH WITH ORDER

MINIMUM \$2.50

**HELP WANTED:** Bldg. Specif. Writers for arch. work—perm. Civil Service \$395 & \$440 month. Annual increases, sick leave, retirement, L. A. County Civil Service, Rm. 102, Hall of Records, Los Angeles 12, Calif.

**ARCHITECT'S REPORTS**—A valuable advance news service giving building and construction information daily on projects in Northern California. Name, location, archi-

tect, proposed cost, etc., on individual slips. Ideal for securing new business leads. Hundreds of items, total monthly cost only \$10. Don't delay, subscribe today. ARCHITECT & ENGINEER, Room 618, 68 Post Street, San Francisco, California. Phone DOUGLAS 2-8311.

**PHOTOGRAPHS:** Specializing in building and construction photographs for publication, or historic records. For Industrial-Aerial-Publicity photography use the INDUSTRIAL

PHOTO'S, Room 722, Hearst Bldg., San Francisco, Phone SUTTER 1-6953.

**METAL WINDOWS** (Steel-Aluminum-Bronze). Large Stock, ALL TYPES, STEEL SASH SALES & SERVICE, Weehawken, N. J.

**ENGRAVING**—Good engravings are essential to a satisfactory job of printing reproduction. For the best, see Poor Richard Photo Engraving Co., 324 Commercial St., San Francisco.

# SISALKRAFT

REG. U. S. PAT. OFF.

*"More than a building paper"*

## THE SISALKRAFT CO.

205 West Wacker Drive  
Chicago, Ill.

55 New Montgomery Street  
San Francisco, Calif.

## CLINTON CONSTRUCTION CO. OF CALIFORNIA

### General Contractors

923 FOLSOM STREET • SAN FRANCISCO

SUtter 1-3440

## HOGAN LUMBER CO.

Wholesale and Retail

### LUMBER

MILL WORK • SASH & DOORS

Office, Mill, Yard and Docks  
SECOND AND ALICE STREETS • OAKLAND, CALIF.

Telephone GLencourt 1-6861

## SANTA MARIA INN SANTA MARIA, CALIFORNIA

FRANK J. McCOY, General Manager

FERNAND E. PIMENTEL, Manager

On the  
Coast  
Highway  
between  
San  
Francisco  
and  
Los  
Angeles



American  
or  
European  
Plan  
•  
Old  
English  
Tap  
Room

Cost of the project, which is located on Carson City and Mount Rose Highway, is estimated at \$500,000.

NURSING HOME CPA Permit granted for construction of a 52-bed nursing home at Sacramento, California, to cost \$110,000. Leonard F. Starks, Architect.

### NEW SKYSCRAPER FOR SAN FRANCISCO

The Standard Oil Company of California have announced the construction of a new office building to be erected on Bush Street, San Francisco.

The building will be 22 stories and basement, of reinforced concrete and steel construction, with terra cotta exterior. Harry A. Thomsen & Aleck L. Wilson, San Francisco, are the architects.

MORGAN F. WILLEY, representing the Sloan Valve Co., Elkay Manufacturing Co., is now located at 65 9th Street San Francisco, California.

### AIR-CONDITIONING

A permanent far-reaching policy of holding national refrigeration and air-conditioning exhibitions, centering around one all-industry show every two years was announced recently by the Refrigeration Equipment Manufacturers Association.

Inaugurating the policy will be the Fifth All-Industry Exposition, which will be held in the Cleveland Public Auditorium beginning January 26, 1948.

ABATTOIR BUILDING for the Kaufmann Meat Company, San Jose, California, will cost \$450,000 according to a contract awarded to the Gresham Construction Company of Sunnyvale, California.

### BOILERS

Carroll M. Baumgardner, of the Institute of Boiler and Radiator Manufacturers, believes that in the future boilers will be as decorative as any other home appliance and will no longer be relegated to an obscure corner of the basement. He points out that the trend is toward streamlined beauty in jackets as well as automatic, finger-tip operation of heating plants.

### SEWAGE TREATMENT PLANT

A contract has been awarded to Barrett & Hilp, San Francisco, contracting firm for the construction of the South Side sewage treatment plant at Stockton, California.

The work, consisting of reinforced concrete construction, will cost in the neighborhood of \$1,330,000, according to Clyde C. Kennedy, consulting engineer.



## BOOK REVIEWS PAMPHLETS AND CATALOGUES

**HOUSES FOR MODERATE MEANS.** By R. Randal Phillips, Hon. A.R.I.B.A. Transatlantic Arts, Inc., New York. Price \$3.00

This is a Second Edition, considerably revised and enlarged, by the author, who has written many successful books on the subject of housing.

In selecting his subject Mr. Phillips recognizes that what is considered "moderate" by one person might be viewed differently by another. He has therefore selected for examples groups of houses which vary in price from \$2500 to \$10,000. Even this price range is only approximate as the presentation is made on the basis of construction costs in England.

About 100 houses are shown in the book, so that anyone interested in the building of a new home is given an excellent opportunity to select features which appeal to them, or meet their particular needs.

**FLUORESCENT LIGHTING MANUAL.** By Charles L. Amick. McGraw-Hill Book Company, Inc., New York. Price \$4.00.

The author, Charles L. Amick, Lamp Department, General Electric Company, Nela Park Engineering Division, has prepared a second edition of this book which deals with the newer principles of operation, design, construction, and performance characteristics of all types of fluorescent lamps.

Graphs, charts, and illustrations provide manufacturers, contractors, dealers, and users with a complete reference manual for solving various problems of modern fluorescent lighting practice.

**CHAPMAN, "Penta" Preservative.** Chapman Chemical Co., Chicago 1, Ill.

A colorful new booklet telling how modern chemistry is making wood last longer; discusses the chemical nature of pentachlorophenol. All lumber treating plants and users of wood will be interested in this striking and instructive booklet. Copies from Chapman.

**CATALOG OF REFRACTORIES.** Robinson Clay Products Co., Akron, Ohio.

New loose-leaf catalog containing latest data on fire brick and refractories. Has seven sections with complete brick tables; estimates for any building relining, repairing, or rebuilding. Castable refractories, bonding mortars, fire brick, silica brick, patching mortars and acid proof cements are thoroughly discussed. Available by writing manufacturer.

## VERMONT MARBLE COMPANY

Producers and Finishers  
of  
Domestic and Imported Marbles

525 MARKET STREET, SAN FRANCISCO  
Phone Sutter 1-6747  
3522 COUNCIL STREET  
(Beverly Blvd. at Virgil Ave.)  
LOS ANGELES 4, CALIF.  
Telephone Fairfax 7834



The Most Complete Line of  
STEELS and BUILDING MATERIALS  
Made by a Single Producer



See Sweet's Catalog File or write us for  
full information.

**REPUBLIC STEEL CORPORATION**

GENERAL OFFICES: CLEVELAND, OHIO

DENVER, COLORADO . . . . . CONTINENTAL OIL BUILDING  
LOS ANGELES, CALIFORNIA . . . . . EDISON BUILDING  
SALT LAKE CITY, UTAH . . . . . WALKER BANK BUILDING  
SAN FRANCISCO, CALIFORNIA . . . . . RIALTO BUILDING  
SEATTLE, WASH. . . . . WHITE-HENRY-STUART BUILDING

## PACIFIC MANUFACTURING CO.

HIGH CLASS INTERIOR FINISH  
QUALITY MILLWORK

142 SANSOME ST., SAN FRANCISCO  
GARfield 1-7755

6820 MCKINLEY AVE., LOS ANGELES  
THornwall 4196

**BUILDERS EXCHANGE, OAKLAND**

## "AMERICAN - MARSH" CONDENSATION UNIT

Pumping  
Machinery  
for  
Every  
Purpose

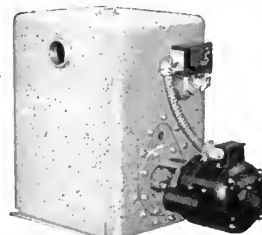

For Service  
Call  
DOuglas  
2-6794  
or  
MUtual 8322

**SIMONDS MACHINERY CO.**  
SAN FRANCISCO 816 FOLSOM  
LOS ANGELES 455 EAST 4TH

## IN THE NEWS

**GRAMMAR SCHOOL** plans for Lakeport, California, have been approved according to C. A. Caulkins, Jr., Architect, of Santa Rosa.

### RETIRES

After 39 years service with subsidiaries of U. S. Steel Corp'n, E. W. Long, Claims Bureau Chief for Columbia Steel Company, retired on November 1, 1947.

**Brownskin**  
**VAPORSEAL**

The resilient building paper creped to S-T-R-E-T-C-H

Quality Products Since 1895  
**ANGIER PACIFIC CORPORATION**  
55 NEW MONTGOMERY ST. 7424 SUNSET BOULEVARD  
SAN FRANCISCO 5, CALIF. LOS ANGELES 46, CALIF.  
A complete line of Angier products available from your building material dealer

He began his steel career as a freight clerk with the American Steel and Wire Company.

### CELLAR WINDOW CATCH

A new styling and major improvement in cellar window fasteners has been announced by the STANLEY WORKS of New Britain, Conn.



The former friction element of style 1763 has been replaced by a steel, dished washer, located between the catch and the plate for protection and long-lasting performance. The mounting plate permits a flush application of the fastener to the window frame.

### BOND ELECTIONS TO BE HELD

Voters in Richmond and Martinez, California, will go to the polls in February to vote on whether extensive school additions will be undertaken. Richmond has before

them a project involving \$3,590,000, while the Martinez school improvements will cost an estimated \$1,500,000.

**JOSEPH BARNES**, General Contractor, San Francisco, has been awarded contract for the construction of a \$800,000 printing plant at San Bruno, California, for the H. S. Crocker Co.

**DRAGON, SCHMIDTS & HARDMAN**, Architects of Berkeley, California, announce that the Central California Construction Co., San Francisco, have been awarded a \$253,412 contract for the construction of a 12-classroom, kindergarten and auxiliary building addition to the Thomas Jefferson School at San Leandro, California.

**SCHOOL BONDS VOTED** and approval of State Architect is awaited in connection with the construction of a \$240,000 grammar school building at Mountain View, California. Birge M. Clark & Walter Stromquist, Palo Alto are the architects.

**CLYDE C. KENNEDY**, Consulting Engineer, San Francisco is working on a \$1,400,000 sewage treatment plant for the City of Stockton, California.

**CONVENT ADDITION**. Carrico & Gautier, Contractors, San Francisco, have been awarded a contract for a \$100,000 addition to Our Lady of Mt. Carmel Parish, Redwood City.

**SCHOOL CONTRACT AWARDED** to Wilfred H. May, general contractor, Belmont, California for the construction of a \$164,000 seven classroom school building at Millbrae, California. Masten & Hurd, San Francisco, are the architects.

**ARCHITECT ARTHUR D. JANSSEN**, Atherton, California, has announced the construction of a \$47,972 residence in Redwood City.

**CONTRACT** has been awarded Cattich & Stevenson, contractors of Redwood City, California, to construct a \$57,654 swimming pool at the Livermore Union High School. Fred L. Swartz & Wm. G. Hyberg, Fresno, Architects.

## MORE WINDOW VALUE FOR YOUR MONEY!

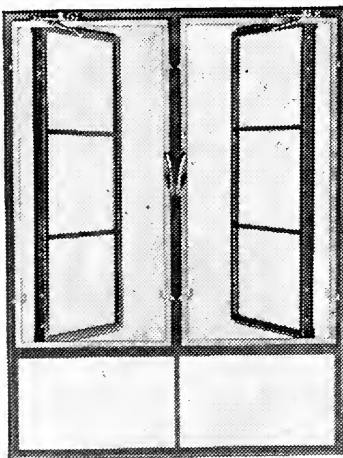

### with CECO Steel Windows

- Easy opening and closing . . . no sticking or warping.
- "Bonded" as a protection against rust.
- Ceco steel windows provide for economical wall construction . . . enhance the architectural effect of the building.
- Weathertight . . . durable and fire resistive.
- The Ceco window line is so complete and so flexible that every type of building from the small residence to the largest institutional structure may be equipped with tight weather seal Ceco steel windows.

CONTACT THE NEAREST P.C.A. OFFICE

## P.C.A. Pacific Coast Aggregates, Inc.

SAN FRANCISCO  
400 Alabama St.  
KLondike 2-1616

OAKLAND  
2400 Peralta St.  
GLencourt 1-0177

SACRAMENTO  
16th and A Sts.  
Ph. 3-6586

STOCKTON  
1020 E. Main St.  
Phone 8-8643

SAN JOSE  
790 Stockton Ave.  
Ballard 8670

FRESNO  
2150 G St. or 414 P St.  
Ph. 3-5168 Ph. 4-3065

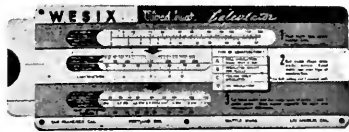

**WESIX** *Wired Heat* CALCULATOR  
 "Slide-rule" style, for quick computing of the correct WESIX Wiredheat SYSTEM for any house. Available to architects, engineers, contractors and dealers.

**WESIX ELECTRIC HEATER CO.**  
 390 First Street, San Francisco

## THE TORMEY COMPANY

**GENERAL PAINTERS  
 AND DECORATORS**

Phone Underhill 1-1913

563 FULTON STREET  
 San Francisco

## MULLEN MFG. COMPANY

BANK, STORE AND OFFICE  
 FIXTURES—CABINET WORK  
 OF GUARANTEED QUALITY  
 CHURCH SEATING

Office and Factory  
 60-80 RAUSCH ST., Bet. 7th and 8th Sts.  
 San Francisco  
 Telephone UNDERhill 1-5815

*Fine*  
**ENGRAVINGS**  
**POOR RICHARD**  
 PHOTO ENGRAVING CO.  
 320-324 COMMERCIAL STREET  
 SAN FRANCISCO, 11

**NEW JUNIOR COLLEGE** and High School buildings are being planned for Monterey, California. Robert Stanton and Crespi Lane, have been selected as the Architects. The cost is estimated at \$1,000,000.

**HIGH SCHOOL CONTRACT** has been awarded to the Baldwin, Straub Corp'n, San Rafael, California, for construction of a 10-classroom High School Addition at Arcata, California. Cost \$165,730, Masten & Hurd, San Francisco, are the architects.

**SCHOOL BONDS VOTED.** Lafayette, California, voters have approved \$540,000 for construction of a new girls gymnasium, seven class-room wing, and alterations to the present High School buildings.

**SWIMMING POOL.** Peter Kiewit Sons, San Francisco, contractors, have been awarded a contract for the construction of a \$69,102 swimming pool and bath house at the Moffett Field Naval Air Station, Santa Clara county.

**ARCHITECT J. S. GOULD,** San Francisco, announces contract has been let to Ed. Desjardin for construction of a \$100,000 Methodist Church at Crescent City, California.

**STORE BUILDING.** The Pacific Builders, Salinas, have been awarded a contract for the construction of a \$200,000 Woolworth building at Salinas, California.

**C. H. THRAMS,** General Contractor, Oakland, has been awarded contract for the construction of a \$135,000 warehouse addition to the Gerber Products Company, Oakland.

**BONDS** have been voted for construction of a \$150,000 swimming pool at Redding, California.

**CAHILL CONSTRUCTION** Company, San Francisco, have been awarded contract for construction of a \$225,000 can factory at San Leandro, California.

**JOHN E. DINWIDDIE,** Architect, San Francisco, has announced the construction of a \$100,000 Clinic Building at Menlo Park, California.

## DINWIDDIE CONSTRUCTION COMPANY

**BUILDERS**

CROCKER BUILDING  
 SAN FRANCISCO



## HERRICK IRON WORKS

**STRUCTURAL STEEL  
 REINFORCING STEEL**

18TH AND CAMPBELL STS.  
 OAKLAND, CALIF.  
 Phone GLencourt 1-1767

Phone GARfield 1-1164

## Thomas B. Hunter

DESIGNER OF HEATING

AIR CONDITIONING  
 VENTILATING AND WIRING  
 SYSTEMS, MECHANICAL  
 AND ELECTRICAL EQUIP-  
 MENT OF BUILDINGS

★  
 41 SUTTER STREET  
 ROOM 710  
 San Francisco California

## Scott Company

HEATING . . PLUMBING . . TILE

★  
 243 MINNA STREET  
 SAN FRANCISCO  
 Phone EXbrook 2-6741

## PITTSBURGH TESTING LABORATORY

Successors to  
SMITH, EMERY & COMPANY

*Testing and Inspecting  
Engineers and Chemists*

Structural Materials, Structures  
Equipment, Pipe, Soils.

651 Howard St., San Francisco 5  
EXbrook 2-1747

## A. F. MATTOCK CO.

*Builders*



212 CLARA STREET  
SAN FRANCISCO

## INDEPENDENT IRON WORKS

Steel Buildings  
Service Stations  
Steel Storage Tanks  
Fabricated Plate Work  
Steel & Sheet Metal Products  
Fabricated Structural Steel  
Steel Distributors

Eighth & Pine Sts. Oakland, 7

## George F. Brayer

ELECTRICAL  
CONTRACTOR

166 Seventh Street  
San Francisco

Phone: Market 1-1761

## Index to Advertisers

ALADDIN Heating Corp. .... 46  
ALLIED Painters & Decorators 25  
ANGIER Pacific Corp. .... 44  
ARCHITECTS Reports ..... 38  
ARCHITECT and Engineer.....  
Inside Front Cover

BASALT Rock Company..... Back Cover  
BAXTER & Company, J. H. .... 34  
BRAUN, E. C., Co. .... 28  
BRAYER, Geo. F. .... 46

CALIFORNIA Electric Co. .... 28  
CHRISTENSEN & Lyons..... 26  
CLASSIFIED Advertising ..... 41  
CLINTON Construction Company... 42  
CLINTON Mill & Mfg. Co. .... 23  
CONDICK Co. .... 22

DETROIT Steel Products Co. .... 8  
DINWIDDIE Construction Co. .... 45

FORDERER Cornice Works..... 38  
FOX Tile Co. .... 37  
FULLER, W. P. Co. .... \*

GLIDDEN Co. .... 25  
GUNN, Carle & Company..... 31

HALLERT, Albert ..... 22  
HANKS, Inc., Abbott A. .... 46  
HAWES Drinking Faucet Company... 5  
HERRICK Iron Works..... 45  
HOGAN Lumber Company..... 42  
HUNT, Robert W., Company..... 46  
HUNTER, Thos. B. .... 45

INDEPENDENT Iron Works..... 46

JUDSON, Pacific-Murphy Corp..... 38

KRAFTILE Company ..... 30

MATTOCK, A. F., Co. .... 46  
McKUNE Metal Products Co. .... 27  
MICHEL & Pfeffer Iron Works.....

Inside Back Cover  
MOODY, Sweazey & Rowe..... 23  
MULLEN Mfg. Co. .... 45  
MUELLER Brass Co. .... 2

NORTHERN California Electric  
Bureau ..... 31

PACIFIC Coast Aggregates, Inc. .... 44  
PACIFIC Coast Gas Association..... 7  
PACIFIC Heating & Ventilating Co. 26  
PACIFIC Manufacturing Company ... 43  
PACIFIC Portland Cement Company \*  
PACIFIC Telephone & Telegraph Co. 33  
PITTSBURGH Testing Laboratory... 46  
POOR RICHARD Engraving Co. .... 45

RANSOME Company ..... 27  
REMILLARD-Dandini Co. .... 46  
REPUBLIC Steel Corporation..... 43

SANTA Maria Inn..... 42  
SCOTT Co. .... 45  
SIMONDS Machinery Company..... 43  
SIMPSON Logging Co. .... 6  
SISALKRAFT Company ..... 42  
SMOOT-Holman Co. .... 35  
STANLEY Works, The..... \*

TAYLOR Co., Halsey W. .... 29  
TORMEY Company, The..... 45

U. S. BONDS..... 1

VERMONT Marble Company..... 43

WESIX Company ..... 45  
WOOD, E. K., Lumber Company..... 34

\* Indicates Alternate Months

## A L A D D I N

### Heating Corp.

Specializing in

QUALITY HEATING  
EQUIPMENT

2222 San Pablo Avenue

OAKLAND

TWinoaks 3-1022

## ABBOT A. HANKS, INC. Engineers & Chemists

INSPECTING — TESTING — CONSULTING  
CONCRETE • STEEL • MATERIALS  
CHEMICAL AND TESTING  
LABORATORIES

• RESEARCH AND INVESTIGATION •

TESTS OF STRUCTURAL MATERIALS  
DESIGN OF CONCRETE MIXES  
SHOP AND ERECTION INSPECTION OF  
STRUCTURES AND EQUIPMENT  
INVESTIGATION OF STRUCTURES  
AND MATERIALS  
TESTS AND INVESTIGATION OF  
FOUNDATION SOILS  
FIRE RESISTANCE AND INSULATION  
TESTS

624 Sacramento Street, San Francisco

## Robert W. Hunt Company

ENGINEERS

Inspection - Tests - Consultation

Schools and Other Structures  
Are Built as Designed

*When Construction Materials are  
Inspected at point of Manufacture  
and during Erection by*

ROBERT W. HUNT COMPANY

*Cement, Concrete, Chemical, Metallurgical,  
X-Ray and Physical Laboratories*

Chicago - New York - Pittsburgh  
Los Angeles - All Large Cities

San Francisco, 251 Kearny Street

## REMILLARD-DANDINI Co.

Brick and  
Masonry Products



400 MONTGOMERY STREET

SAN FRANCISCO, CALIF.

# ARCHITECT and ENGINEER

## INDEX TO ARTICLES AND ILLUSTRATIONS

VOLUMES 168-171, 1947

### A

A.I.A. Activities.....	Jan.-Dec. 31
A.I.A. New East Bay Chapter.....	Nov. 31
Air Distribution, Important Phase of Air Conditioning (Leonard R. Phillips).....	Jan. 10
Anemostat Air Diffusers.....	Jan. 13
Apartments, Kelton, Westwood, (Richard J. Neutra).....	Mar. 17
Architects' Acceptance of Materials (Leslie Childs).....	Apr. 14
Architect and the Color Consultant (Eugene Burns).....	Nov. 12
Architectural Practice, Drama in, (Elmer Grey).....	Sept. 35
Architectural Practice, Comedy in, (Elmer Grey).....	Oct. 39
Art News and Comment.....	Jan.-Dec. 6
Autobiography in Color and Light (Orin E. Skinner).....	Feb. 16
Automobiles, Post War (R. M. Schindler).....	Feb. 12
Auto Sales & Service Bldg., W. W. Penhorwood, Santa Rosa (C. A. Caulkins Jr.).....	Sept. 28

### B

Bank of America, Los Angeles.....	Jan. 11
Bridge, World's First Reinforced Concrete Structure (Curtis Tobey).....	Jul. 12

### C

Ceramic Exhibition—6th Annual—City of Paris S. F.....	Jun. 14
Color Consultant and the Architect (Eliz. Banning).....	Nov. 12
Colors, How Many Can We Distinguish, (Dr. W. S. Schweisheimer).....	Mar. 10
Comedy in Architectural Practice (Elmer Grey).....	Oct. 39
Convention, California Council of Architects, Catalina.....	Nov. 35

### D

Drafting, Isogonic, (S. S. Morrill).....	Nov. 22
Drama in Architectural Practice, (Elmer Grey).....	Sept. 35

### E

Editorial Notes (E. H. Wilder).....	Jan.-Dec. 4
Engineering, Research in Seismology (G. W. Housner, Prof.).....	Dec. 16
Engineers, With The.....	Jan.-Dec. 32
Engineers, Emergency Committee Program for Community Disaster Relief (John G. Little).....	Dec. 17
Estimators' Guide.....	Jan.-Dec. 41

### F

Factory Building, Challenge Cream and Butter Association, Berkeley, California (Alben R. Froberg, Architect).....	Dec. 18
Factory Building, W. P. Fuller & Co.....	Aug. 15
Factory Building, Judson Pacific Murphy Corp., Emeryville.....	Jul. 14
Factory Building, Pabco Research Laboratory, Emeryville.....	Nov. 25
Factory Building, Vega Aircraft Co., Burbank.....	Jan. 15

### H

Headline News & Views (Edwin H. Wilder).....	Jan.-Dec. 35
Honor Awards, So. Calif. Chapter, A.I.A.....	Mar. 14
Hotel, California Motel, (James H. Garrott).....	May 16
Hotel, El Rancho, Sacramento, (Fran W. Green).....	Sept. 25
Hotel, Sir Francis Drake, S. F., Starlite Roof.....	Apr. 20
Housing Act, California, Amendments to.....	Oct. 14
Housing, Baldwin Hills Village, Los Angeles (Reginald Johnson).....	Mar. 24
Housing, Channel Heights, San Pedro, (Richard J. Neutra).....	Mar. 14
Housing, Hillside Dormitories, Vallejo, (Cecelia Mogen- sen).....	Nov. 10
House, Tomorrow's Today, Richard Wallberg, S. F. (Wald & Bolles).....	July 16

### I

Insulation (Henry J. Wingate).....	April 15
Insulation, Wood Fiber.....	May 43
Interiors, Four Modern, (Klaus Pfeffer).....	Aug. 13
Isogonic Drafting (S. S. Morrill).....	Nov. 22

### L

<b>Landscaping:</b>	
Garden Designer Sets the Stage (Ruth Jaffe).....	Dec. 13
Gardens, Roof, (Albert Wilson).....	Jan. 16
Gardens, Michael A. Naify, Woodside (Eckbo, Royston & Williams).....	Aug. 16
Landscape Architecture (Ned S. Rucker).....	Oct. 10
Notes to the Profession.....	Aug.-Dec. 38
Planned Commercial Center, Hillside Forms, Vallejo (Cecilia Mogensen).....	Nov. 10
Proposed Pacific Nurseries, Colma (R. Royston).....	Feb. 11
United Airlines Maintenance Base, S. F. (Wayne W. Gray).....	Sept. 18

**M**

Medical Building, Recent Trends In Small (Daniel Gage). April 7  
 Medical Building, Eugene, Ore., (Graham Smith) April 7  
 Murals Starlite Roof, S. F. (John Garth) April 19  
 Murals S. F. Post Office (Refregier) June 9

**O**

Office Building, Westinghouse Elec. Corp., S. F. Mar. 30  
 Office and Store Building, Rexall Drug Co., L. A. (A. F. Roller) Oct. 19

**P**

Planning & Urban Development (Jas. W. Follin) Nov. 27  
 Plywood Performance Standards Established Oct. 18  
 Porcelain Enamel on Steel July 11  
 Prefabrication, What Is It? April 18  
 Producers Council—B. F. Wade and C. J. Nicholas Jan. 38  
 Public Building, County Jail, Portland, Ore. (A. J. Dreyer) Nov. 18  
 Public Building, Stanislaus Co. Court House Jan. 12

**R**

Radar Control Searchlight Feb. 26  
 Rancho Sta Fe (S. R. Nelson) Jan. 20

**Residence:**

Cranwell House, \$13,000, England Jan. 5  
 Custom Made (Elsa Bussard) April 12  
 Kent Woodlands, Marin County (Hervey P. Clark) Nov. Cover  
 John B. Nesbitt, Brentwood (R. J. Neutra) Mar. 20  
 Richard Walberg, San Francisco July 16  
 Restaurant, Starlite Roof, San Francisco April 20

**S**

Stained Glass, Windows of Grace Cathedral (C. J. Connick) Feb. 16  
 Starlite Roof, Sir Francis Drake Hotel, S. F. April 20

**Store Building:**

Apparel City, San Francisco (Ward & Bolles) June 21  
 Robt. S. Atkins, San Francisco (Donald B. Kirby) May 18  
 Auto Sales & Service, W. W. Penhorwood, Sta Rosa (C. A. Caulkins Jr.) Sept. 28  
 Contemporary, in China Town, San Francisco (W. W. Wolf) Oct. 15  
 Fox Tile Co., Oakland (Irwin M. Johnson) Oct. 12  
 Jacksons Furniture Store, Sacramento (H. E. Good-pastor) Sept. 20  
 Merchandise Mart Addition, S. F. Aug. 20  
 Rucker Fuller Desk Co., S. F. (Eugene Burns, C. Bolton White) May 12  
 Rexall Drug Co., Los Angeles (A. F. Roller) Oct. 19  
 Sherman, Clay & Co., Oakland (Theo. C. Bernardi, et al) June 24  
 Andrew Williams, Oakland (Stone & Malloy) June 22  
 Sound Motion Pictures for Schools and Auditoriums (John A. Howland) Mar. 27

**T**

Theatre, U. S. Army, Presidio, S. F. Jan. 10

**U**

United Air Lines Maintenance Base, S. F. (Wayne Gray) Sept. 18

**W**

Weavers Assn. of California Exhibit May 8













