

ARTIFICIAL DYE-STUFFS

CHAPTER I

INTRODUCTION

FROM the very earliest times the production of colouring matters for various purposes has engaged the attention of man. In the savage state he coloured his own body, for example, with the woad of the Britons whom Cæsar found in this country ; whilst as civilisation advanced, buildings, domestic articles, and clothing became the subjects which man chose to adorn with pigments which he was able to obtain from a variety of natural sources. In developing the art of colouring substances two forces had constantly to be encountered ; namely, the action of light and that of water, the former bleaching white or changing a shade, and the latter washing away colours altogether. How greatly the art of preparing fast-colouring matters had developed even so long ago as the days of ancient Egypt is shown by the remarkable paintings and decorations which adorn their temples and other buildings, and are as fresh to-day, after several thousand years of the fierce Egyptian sun, as when they were finished.

Man's first efforts in the direction of dyeing were probably the production of fugitive stains with juices and decoctions obtained from berries, flowers, and other vegetable matter. At a later period accident

or experiment showed that by the use in conjunction with these vegetable matters of earth or mud containing alumina and iron these stains could be rendered more permanent and the effects of light and water counteracted.

A number of these vegetable dyes, such as indigo, madder, and woad, are in use at the present day, although, as we shall see later, they are almost entirely superseded by dyes of an artificial nature. As an indication of their antiquity, however, it may be mentioned that some years ago investigations carried out in connection with some Egyptian mummy cloths of very great age revealed the presence of indigo and madder colouring matters.

The use of dye-stuffs appears to have been brought almost to a state of perfection by the ancients, and although few examples of their work remain, owing to the perishable nature of fabrics, there is sufficient in existence to prove that the manufacture and use of dye-stuffs constituted not only a widely practised art, but one in which very highly prized results were obtained, as evidenced by the famous purple of Tyre. This dye, which had become famous 1000 B.C., and produced the purple robes of the Roman emperors, is now generally concluded to have been obtained from a certain kind of mollusc or sea-snail which is found throughout the Mediterranean Sea. These creatures contain a pus-like matter secreted near their shells, which was diluted with water in which the fabrics were subsequently steeped. Exposure to sunlight, which was essential to the process, caused the colour to change rapidly from yellow to light then deep green, and finally to a purplish red or crimson, known respectively as the Byzantine and Tyrian dyes. We shall see in a later chapter how this principle of obtaining colours by the

action of light has been applied in a very recently discovered series of artificial dye-stuffs.

The molluscs from which the dyers of Tyre obtained their raw material were called by the Roman writer Pliny "purpura," from which our word purple is derived. It is interesting to note that in excavating the ruins of Pompeii an ancient dye-works was among the discoveries, large quantities of shells being found near by.

Another important natural dye-stuff is madder root, which is known to have been used in very early times by the Egyptians, Persians, and Indians, the general supposition being that the latter were the originators of its use ; but so indefinite are the records that its origin may fairly be said to be lost in the mists of antiquity. It is, however, tolerably certain that under the influence of Alexander the Great a number of dye-stuffs and the methods of their use were introduced from India, first to Greece and subsequently to Rome, under whose imperial sway numbers of arts and crafts were spread over Western Europe, to be developed subsequently by the Celtic and Teutonic races, to whom the Romans had given their first impulse of civilisation.

By the time of the Crusades the cultivation of madder became very extensive in France and Northern Italy, and for many centuries the madder root continued to be one of the most important of the raw materials used in the dyeing industry. The usual method of preparing the dye consisted in drying the roots thoroughly either in the sun or in kilns, washing with water, and grinding to a very fine powder. The root and sometimes the whole plant were known on the Continent as alizari, the source of the word alizarin, which was applied to the actual colouring matter isolated from madder in the year 1827.

In the thirteenth century the dye industry was

largely fostered by Venetian merchants, and a little later, in the year 1429, the first European book on Dyeing was published at Venice. In the reign of Edward III. Flemish dyers were brought to England ; and their art was taken up in this country to such an extent that the Dyers Company was formed in the City of London in the year 1472.

The discovery of America by Columbus in 1492 and the route to India via the Cape of Good Hope in 1498 were two important events for the European dye industries, in that not only was the transit of Oriental dye-stuffs considerably facilitated and the imports thereof to Europe increased, but the way was opened up to the discovery of numbers of hitherto unknown dyes. For instance, among many remarkable discoveries made by the Spaniards during their invasion of Mexico in the year 1518 was that of cochineal, a red—or, more strictly speaking—a carmine dye-stuff made from an insect found throughout Central America, and still extensively used as a colouring matter.

The year 1630 is a very important one in the history of dye-stuffs, for in that year a Dutch chemist named Drebbel discovered accidentally that a finer scarlet than had yet been known was to be obtained by dyeing with cochineal after mordanting with a solution of tin. Tin has subsequently proved itself to be one of the most useful of mordants, and of late years mordant dyes have become especially prominent, more particularly in dyeing cotton fabrics, upon which colours are otherwise very fugitive. By impregnating these fabrics, however, with various metallic compounds, and especially with those of aluminium and chromium, not only are beautiful and fast colours obtained, but colours are produced with substances which in themselves do not possess dyeing properties.

Drebbel's discovery, therefore, marked a new era in the dyeing industry, and a fresh impetus was given to the trade, which became of sufficient importance for the Royal Society to publish in the year 1662 the first book on dyeing in the English language.

For the next two hundred years the natural dye-stuffs held the field, new ones being introduced from time to time, as well as new mordants. The middle of the nineteenth century, however, saw the beginning of a revolution in this as in many other industries. Various factors combined to forward the new movements, the changing economic conditions made it almost a necessity to try and effect a utilisation of what had hitherto been waste products, and, further, chemists were beginning to make extensive researches into the hitherto almost unexplored field of the Chemistry of Organic Substances.

Until this time the idea had prevailed that organic matters, that is, animal and vegetable substances, were essentially different from the inorganic ones, and could not be prepared artificially owing to the intervention of a supposed "vital force." In the year 1828, however, this idea was shown to be incorrect, for a chemist named Wöhler prepared in his laboratory a substance previously obtained solely from living creatures, a great impetus being given thereby to the development of organic research. Chemists began to analyse large numbers of organic substances, and having ascertained their constitution, to build them up from the elements known to compose them. By this means, the actual chemical composition of the historic vegetable dye-stuffs was made known, and, after many experiments, it has been possible to produce these dye-stuffs artificially, although it is only in very recent years that their manufacture on a commercial scale has been

rendered possible. It was found, moreover, that many of these artificial dyes gave far better colours than the natural products, on account of the fact that the colouring properties of the latter were often due to constituent parts only ; for instance, the dyeing properties of the madder root were found to be due to the alizarin and purpurine which it contained in combination with other substances. Similarly indigo, when subjected to dry distillation in the year 1826 by Unverdorben, was found to contain a colouring matter which was called aniline, from the word *anil*, the Portuguese name for indigo, which is itself a Greek word meaning the " Indian dye."

We must now turn for a moment to another industry which developed during the first half of the nineteenth century, namely, that of the dry distillation of coal for the production of illuminating gas. For a time, and, indeed, until well within living memory, the by-products of this industry were considered to be of so little use that gas manufacturers almost gave them away ; but with the increased utilitarianism that began to mark commercial life came a scientific investigation of these by-products, which speedily produced very remarkable and far-reaching results.

As will be seen from the following chapter, when the condensed tar from the dry distillation of coal is itself distilled at gradually increasing temperatures, a process known as fractional distillation, a series of oils known as aromatic hydrocarbons is obtained, the specific gravities of which increase as the temperature rises. The best known of these oils are benzene, toluene, used largely in the manufacture of explosives, naphthalene, used as a burning oil, and the heavy oil anthracene. A number of other oils are also present in smaller quantities, and in the year 1834 a German chemist,

Runge, discovered one of their number to be identical in composition with the aniline obtained from indigo by Unverdorben eight years previously. The extremely small proportions in which it was present, however, rendered it of little use commercially, until some little time later it was produced by treating benzene with nitric acid. The chemical nature of several other constituents of coal-tar was revealed by A. W. Hofmann during the years 1842-63, but the industry of the synthetic dye-stuffs really dates from the year 1856, when W. H. Perkin produced a mauve colouring matter by oxidising aniline. Perkin's discovery was quite accidental and took place while Hofmann, to whom he was assistant, was away on a holiday. The young assistant was endeavouring to manufacture artificially the important drug known as quinine. The experiment failed in its object, but produced instead a mauve colouring matter which he showed to Hofmann, who advised him to throw it away. Nothing daunted, however, the energetic young chemist investigated his discovery thoroughly, and before long had started the manufacture of it on a commercial scale. It is worthy of note that for a great number of years, concluding with the death of Queen Victoria, the English penny postage-stamps were coloured with Perkin's mauve dye, thereby offering a singular tribute to the man who had given such an impetus by his energies to the development of the dye industry. Perkin was subsequently knighted in recognition of his work in this direction.

After Perkin's discovery other discoveries of new artificial dye-stuffs quickly followed, and in 1859 the important dye-stuff Fuchsine was isolated by Verguin, and soon afterwards aniline blue was discovered.

As already stated, the colouring matter was isolated

from madder in the year 1827, but at first considerable difficulties occurred in obtaining alizarin in a state pure enough for its composition to be determined with exactitude. After many unsuccessful attempts had been made, a German chemist, Graebe, commenced a series of researches, which ended in proving what alizarin really was and resulted in its synthetic production. He found that alizarin consisted to a large extent of carbon and hydrogen, and, judging from what was already known of the hydrocarbon benzene and its compounds, concluded that alizarin was itself derived from a hydrocarbon base. By applying one of the methods employed to obtain benzene from its compounds he obtained a crystalline substance from alizarin which proved to be identical in composition with the anthracene obtained from the distillation of coal-tar. It was only necessary then to reverse the process to obtain artificial alizarin, and after many attempts had been made Graebe and Liebermann were successful in 1868. Several years elapsed, however, before Perkin devised a process which was commercially successful.

While the foregoing developments were in progress, researches were being carried out in other directions, and numbers of derivatives, not only of aniline, but of the hydrocarbons, such as toluene, naphthalene, and xylene were produced, many being found suitable for use as dye-stuffs. The Azo dyes, which now form the largest group of artificial dyes, were first put on the market in the year 1876, although the first of these compounds, aminoazobenzene, was produced from aniline as early as 1861.

From the earlier and simpler azo dyes have been developed a large series of direct cotton dyes—an exceedingly important development, in view of the

difficulties formerly experienced in producing fast colours on cotton.

The last of the historic vegetable colouring matters to be produced artificially was indigo. This blue dye was produced for many centuries in India from the juices of several plants of a certain species. The juice is practically colourless, but, on continued exposure to air, oxygen is taken into combination and indigo is formed. As indigo is insensitive to the action of light, air, acids, and alkalis, as well as being fast to washing, its value as a dye will be readily appreciated. There is in addition a European plant called woad, from which indigo can be obtained, although in smaller proportions than from the Indian plants. The use of this plant is of considerable antiquity, and owing to the difficulties in the Middle Ages of transporting indigo from the East, the woad plant attained considerable importance and was very largely cultivated, especially in certain districts in Germany. As trade with India grew, and shipping facilities increased, the European indigo manufacturers could no longer compete with the much cheapened Indian product, which for a considerable period controlled the markets of the world.

Having successfully produced artificial alizarin and other dye-stuffs, the energies of scientists were at once turned to the problem of the production of artificial indigo. Many attempts were made, and in the year 1880 von Baeyer achieved success. The process, however, was more expensive than the production of natural indigo, and it took seventeen years of careful research before artificial indigo was placed on the market in 1897 at a moderate price; and its success as a dye may be judged from the great reduction which has taken place in the last few years in the area devoted to the cultivation of indigo in India.

Another interesting dye-stuff which is now prepared artificially is picric acid, much better known as a high explosive. This substance was first produced in 1771 by the action of nitric acid on silk and other animal products. It is now made exclusively by the nitration of phenol, or carbolic acid, a coal-tar product, and is known chemically as tri-nitro-phenol. Picric acid is still used for dyeing animal fibres, such as wool and silk, yellow.

Although a number of vegetable dye-stuffs, such as cochineal, logwood, gamboge, turmeric, and red-wood, and mineral dyes, such as iron buff, manganese brown, and prussian blue are still in fairly general use, the great majority of modern dye-stuffs are coal-tar derivatives; and as new compounds are constantly being introduced, giving more brilliant and faster colours, the artificial dye-stuffs have every prospect of entirely superseding the natural products at a no very distant date.

Up to the present time artificial colour manufacturers have been almost entirely dependent upon the by-products of coal-gas production for their raw materials, but, as will be seen from the following chapter, the yield of hydrocarbon products from the dry distillation of coal is in very small proportion to the quantity of coal treated. Of these products a considerable amount is needed for purposes other than the manufacture of dye-stuffs, such, for instance, as burning and lubrication.

The world's output of benzene, toluene, and allied substances is likely to be augmented considerably, in future, however, by the use of a process which has recently been worked successfully in America, by which heavy mineral oils, such as petroleum, are passed through a steel tube, subjected to high temperature

and pressure, and cracked into oils of much lower boiling point. By this means benzene and toluene have been obtained directly from petroleum and kerosene, thirty gallons having been treated in an hour. When this is contrasted with the twelve gallons of coal-tar which is obtained on an average from each ton of coal, it will be evident that the supply of raw material to the dye manufacturer should be considerably cheapened in future.

It is a matter of constant comment that although the first aniline dye was produced by an Englishman, the subsequent researches and commercial exploitation of the new products have been to a very large extent carried on by Germans. The English manufacturer is frequently blamed for his lack of initiative and his failure to encourage research on the part of his works' chemists; but although, unfortunately, this may have been the case in some instances, it should be remembered that even the progressive English dye manufacturers were heavily handicapped by the inequalities of the Patent laws of this country. Under the laws existing prior to the year 1907 there was no provision which compelled a foreigner possessing an English patent to work that patent in this country. Owing to this defect a number of blocking patents were obtained by German firms, by which they were enabled to manufacture exclusively in their own country for the English market, whilst the English manufacturers were kept out of the market for fourteen years, and often longer, owing to inaccurate information given in the specifications of these German-owned patents. At last, however, a change was made, and not only was a more thorough examination of all patent specifications instituted, but owing very largely to the activities of Mr. Levinstein, a dye manufacturer of Manchester,

clauses were inserted in the Patents and Designs Act of 1907 under which, if an invention is insufficiently worked in this country, a manufacturer may apply to the Court to compel the patentee to grant him a license to work it ; or if the invention is worked wholly abroad the patent may be revoked entirely, and British manufacturers be free to exercise the invention for their own and the country's benefit.

These few remarks will illustrate the great difficulties which have beset the artificial dye industry and chemical industry generally in this country in the past, and it is interesting to note that in the few years, during which the new Act has been in operation, a considerable impetus has been given to chemical industry.

As regards the future of the artificial dye industry, it is evident from the number of new plants that are being erected, some of which are receiving Government aid, that a great effort is to be made to wrest this important industry from German hands ; but if the feat is to be accomplished and the development of the industry revert to British hands, full scope and encouragement must be given to our works' chemists to emulate the spirit of inquiry which animated the youthful Perkin when he made his epoch-making discovery of the first aniline dye, a discovery that goes most emphatically to prove that "Peace hath her victories no less renowned than war."

CHAPTER II

THE DISTILLATION OF COAL
AND COAL-TAR

It is difficult to imagine, from a mere external examination of a piece of coal, that such an apparently simple substance can in reality have the complex constitution which chemical science has proved it to possess. It is only when it is remembered that coal is formed by the natural decay and compression of organic vegetable matter that its potentialities can be realised, its four chief constituents, namely, carbon, hydrogen, nitrogen, and oxygen, being capable of forming an almost infinite variety of compounds. As far back as 1681 the first patent for the destructive distillation of coal was obtained, the object of the patentees, Becher and Serle, being to obtain coal-tar and pitch, although they were not aware of the great possibilities of coal-tar and the many valuable products which are now known to be obtainable from it.

More than a century later, namely, in 1792, Murdock, a Scottish engineer, carried on the distillation of coal for the production of coal-gas, but for a number of years the tar which condensed from the gases evolved when the coal was heated was regarded more or less as a valueless waste product. In 1815 and 1822, however, the distillation of the coal-tar was carried out in order to produce naphtha, which was used as an illuminating oil, and also as a solvent in the manufacture of rubber goods, for which purpose what is known as "solvent naphtha" is still used.

At the present time something like 800,000 tons of coal-tar are produced annually in this country, which was not only the first to recognise the importance of this substance and to carry on its distillation, but also produces a greater quantity of it than any other country, almost the only source of supply being the gas-works and coke-ovens. Substances such as bituminous shale, peat, bituminous lignite, etc., yield tar when subjected to dry distillation, but tar produced from these substances contains little benzol and a number of paraffinoid oils which are difficult to remove, and is therefore of little or no value from the point of view of the manufacturer of coal-tar dye-stuffs.

One ton of coal usually yields about 140 lbs. of coal-tar, which contains 1.1 lbs. of benzene, .9 lb. of toluene, 1.5 lbs. of phenol, 6.3 lbs. of naphthalene, and .46 lb. of anthracene, so that it will be seen that an enormous amount of coal has to be treated in order to produce the large quantities of the substances mentioned which are at present used in the artificial dye industry. It is very probable, however, that a new source of extensive supply of benzene, toluene, and other similar hydrocarbons will be developed in the near future by the treatment of petroleum oils according to a process referred to in Chapter I. In recent years the ordinary gas retorts have been superseded to some extent by coke-ovens, which have been found more economical for gas manufacture. As, however, higher temperatures are employed, the quality of the tar is deteriorated and its content of benzol diminished; such tar, however, may be, and often is, mixed with tar produced by the older method, before distillation. Fig. 1 shows a section through a coke oven.

The main products of the destructive distillation of coal are three in number, namely, coal-gas, coal-tar,

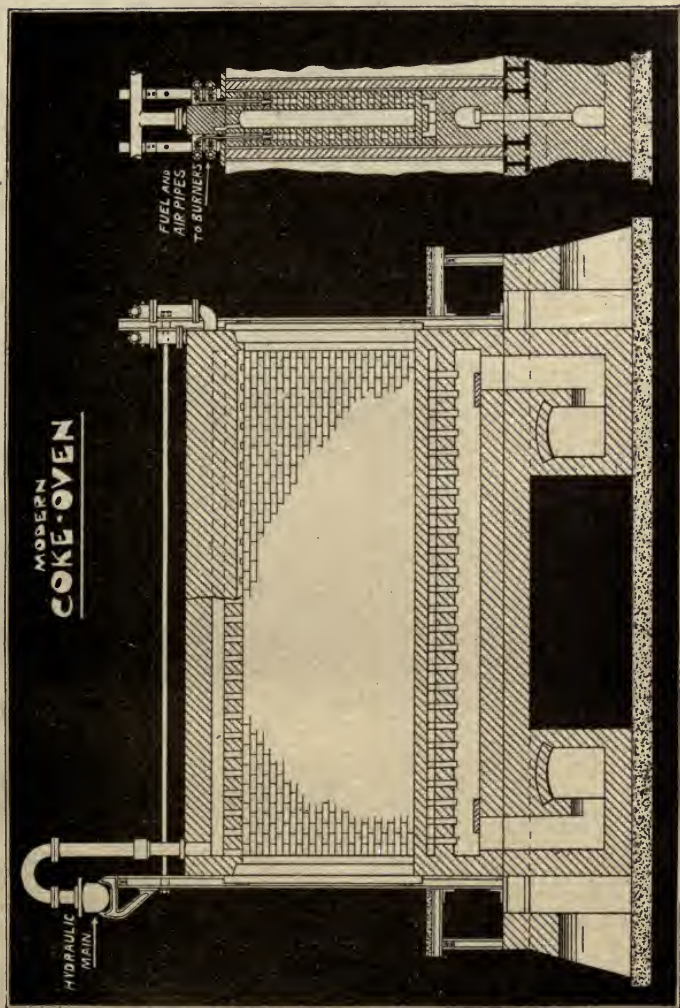

FIG. I.

and ammoniacal liquor, but as only the second of these is of interest to us in connection with the manufacture of artificial dye-stuffs, we shall not describe the treatment of the remaining distillation products beyond the stage at which coal-tar is produced.

The coal is charged into tubular fireclay retorts arranged in groups or batteries, usually of five, which are heated by what is known as the gaseous system, in which the air admitted to the furnace is regulated so as to produce carbon monoxide above the hearth, and carbon dioxide around the retorts. The temperature inside the retorts is raised to about 950° C., and the gaseous products given off ascend a vertical pipe, as shown in Fig. 2, and thence pass into a large horizontal pipe called the "hydraulic main," where a large proportion of the coal-tar is deposited, together with some ammoniacal liquor. The gases then pass on to a series of tubes, or condensers, where more tar is condensed, and they are then conveyed to the scrubbers, which consist of towers filled with coke on which water is sprayed, and here the remaining tar constituents and ammoniacal liquor are extracted. The tar collected in the condensers and scrubbers is allowed to run into what is known as the "tar-well," from whence it is collected and mixed with the tar from the hydraulic main in large settling tanks. The tar remains in the settling tanks until the ammoniacal liquor, with which it is mixed, separates as an upper layer, which is then drawn off, this separation being necessary before the tar is pumped to the tar-stills.

The tar-still is an iron vessel set in brickwork and provided with a concave bottom protected by a brick arch, the top of the still being dome-shaped and having an outlet pipe for conducting the hot gases to a condensing worm. An outlet is provided at the base of the

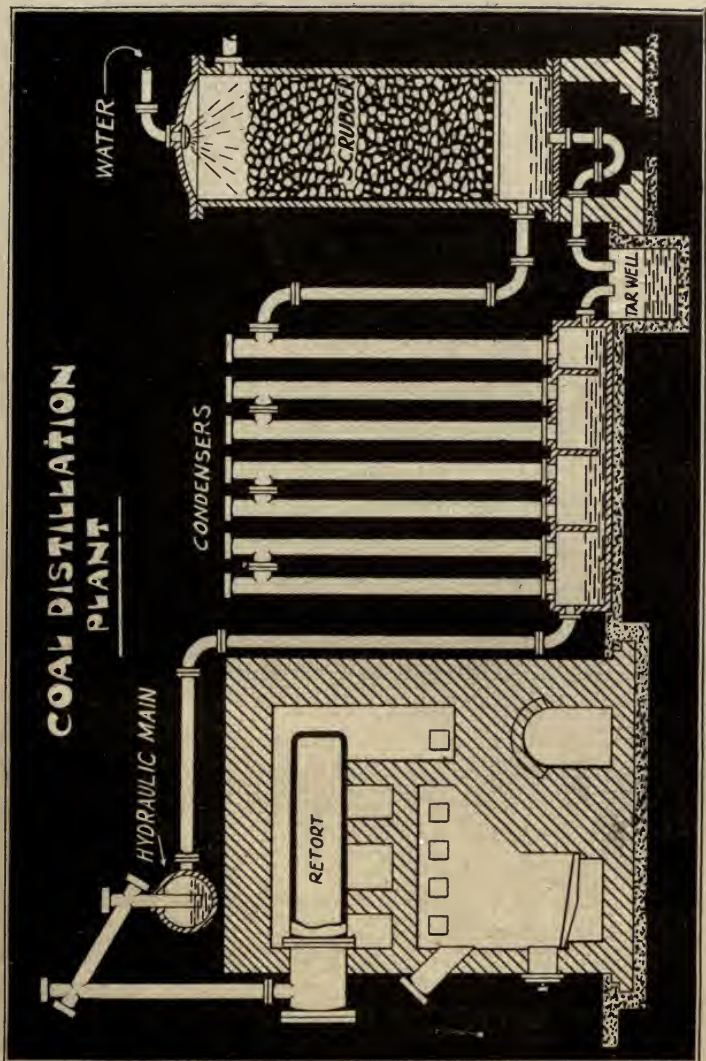

FIG. 2.

still for running out the pitch remaining when the distillation is complete, whilst mounted in the dome-top is a safety valve and a thermometer tube, steam pipes being also led into the vessel terminating in an arrangement of jets at the bottom, the purpose of these being to allow steam to be blown in to prevent the pitch from hardening and caking in the still.

The still is heated from below by a furnace, the gases from which are led through flues surrounding the still as shown in Fig. 3, before finally reaching the smoke shaft. The outlet at the base of the still is connected to a pitch cooler, whilst the gas outlet pipe in the dome is connected to a water-cooled condensing worm which empties its contents into a receiver, the latter being changed from time to time, as the temperature in the still is increased, so as to keep the several "fractions" resulting from the distillation separate.

The size of the still employed varies with different distillers, but the capacity of the average still is about 5,000 gallons of tar, this being run in from the settling tanks whilst the still is warm from the previous distillation.

Coal-tar is a thick, black, viscous fluid having a peculiar smell, its specific gravity being about 1.2, the greater part of it being composed of non-volatile hydrocarbons which are solid at ordinary temperature and form pitch. The volatile constituents of coal-tar are distilled in four fractions according to the temperatures at which they boil. The first fraction, containing oils boiling up to 170° C., is known as the Light oil fraction; the second, or Middle oil, fraction boils up to 230° C.; the third, or Heavy oil fraction, boils up to 270° C.; and the fourth fraction, known as Anthracene oil, boils above 270° C. and up to 400° C.

The temperature of the tar-still is raised gradually, and any water or ammoniacal liquor still remaining in

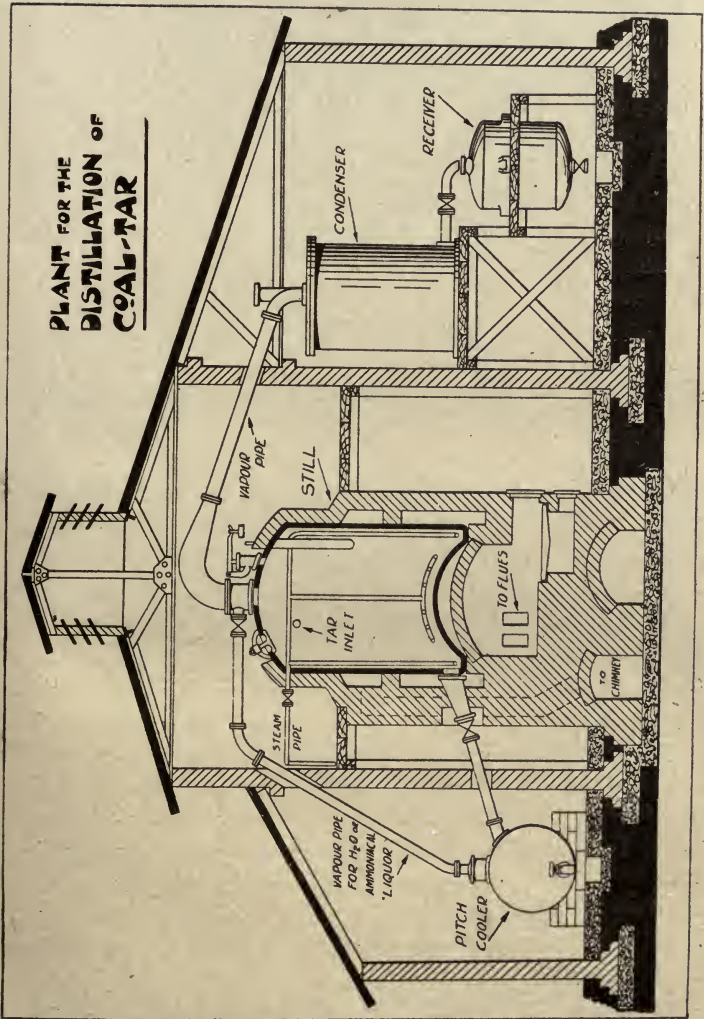

FIG. 3.

the tar comes over ; and when the temperature rises to the degrees mentioned the receiver is changed and the various fractions kept separate. Instead of changing the receiver, the condensing worm may be arranged to empty into a vessel provided with a number of outlet pipes, provided with cocks, one for each fraction, the pipes being connected to separate vessels, so that when the temperature in the still reaches the correct point, the fraction which has collected in the distributing vessel is run off and the vessel is then free to collect the next fraction.

It may be mentioned here that tar is now sometimes distilled by the continuous system, in which a series of stills heated to different temperatures is employed, the tar passing through the several stills in succession and the fractions distilled in this manner.

Of the four fractions thus obtained, one only is made use of without further treatment, namely, the third fraction or heavy oil, which is used for creosoting wood and for other similar purposes.

The remaining three fractions are all subjected to further treatment, the light oils being fractionally distilled, and the middle and anthracene oils left to separate into solid and liquid parts, which are subsequently purified.

The light oils are first distilled through a fractionating column at a temperature not exceeding 170° C., any liquid which does not distil over at that temperature being afterwards added to the middle oils. The redistilled light oils boiling up to 170° C. contain basic and phenolic impurities which have to be removed, and the liquid is therefore run into lead-lined wooden vats, or cast-iron pans, and a quantity of concentrated sulphuric acid, equal to 5 per cent. of the oil to be treated, is run in.

The sulphuric acid extracts the basic impurities by forming salts with them, and it also removes any sulphur compounds which may be present, together with any unsaturated hydrocarbons. The acid forms a layer separate from the oils and is drawn off, and the oils are then washed with water and sodium hydroxide (caustic soda) in order to remove any trace of phenol, after which they are again fractionally distilled.

The fractional distillation of the light oils is carried out in a special form of still, known as a Heckman's Still, to which a fractionating column is connected. The still itself consists of a wrought-iron boiler, as shown in Fig. 4, provided with a series of steam tubes connecting steam chests at either end of the still, the steam passing through these tubes serving to heat the contents of the still to boiling-point. The still is provided with a gauge-glass, safety-valve, and run-off cock, and is connected by means of a swan-neck vapour pipe to the fractionating column. The fractionating column is made in sections, either of cast-iron or mild steel, each section containing a plate provided with hooded vapour pipes and also with a drip pipe. At the base of the column is an S-pipe which allows of the return of liquid to the still, whilst at the top of the column a vapour pipe is attached which is connected to a dephlegmator. The dephlegmator is a cast-iron cylinder about 7 or 8 feet long and 2 feet 6 inches in diameter, provided internally with a tube plate about 18 inches from either end, a number of copper tubes about 1 inch in diameter being expanded into the tube plates. Water is circulated through the copper tubes, between which the vapours from the fractionating column pass, the liquid which is condensed being returned to the column through a U-tube, and the

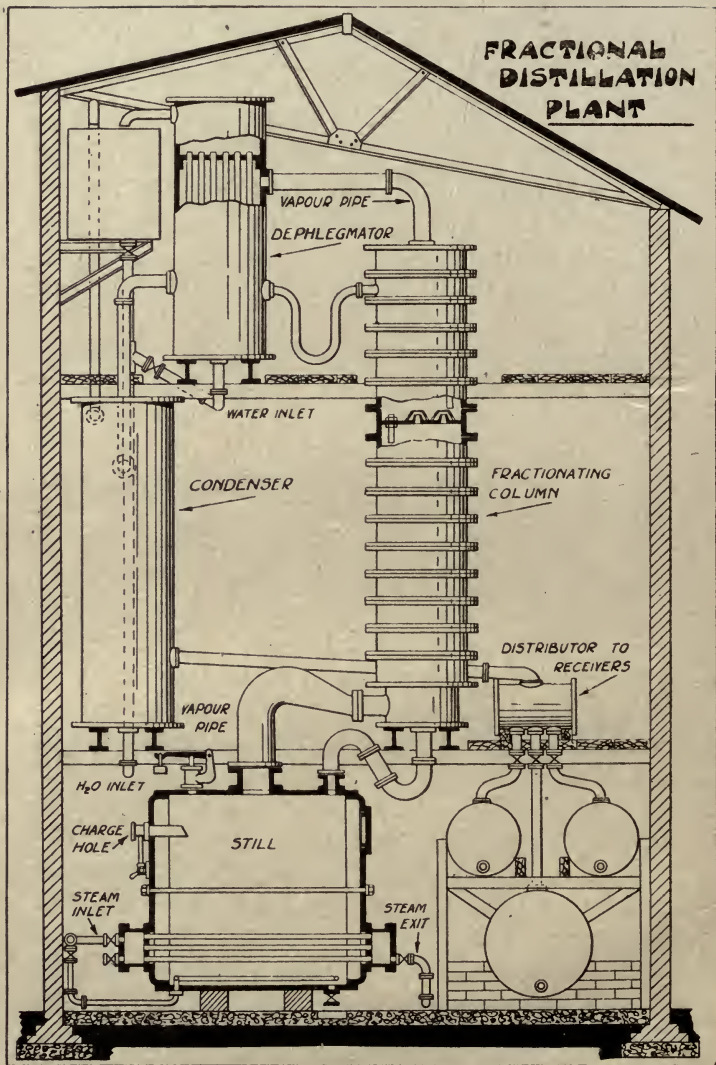
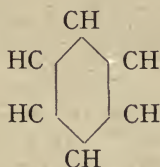

FIG. 4.

uncondensed vapours conducted to a condenser and thence to a receiver from which the several fractions are drawn off. In operation, the still is charged with the light oil fraction obtained from the tar-still, the contents of the still being then boiled by passing steam through the steam tubes, and the vapours produced pass up the swan-neck pipe to the fractionating column, where some of them condense. The condensed liquid overflows from the successive plates or trays of the column into the ones beneath, through the drip pipes provided for this purpose, and are thence returned to the still, whilst the uncondensed vapours pass on to the dephlegmator, where they are partially condensed, the liquid portion returning to the column and the vaporous portion passing to a final condenser. Three fractions are collected from the receiver, namely, benzene, toluene, and xylene, the liquid still remaining in the still being used as solvent naphtha.

Benzene, the lightest of the fractions collected, is a substance of very great importance. It is a colourless liquid boiling at 80° C., and having a specific gravity of $\cdot 879$, its formula being C_6H_6 , which may be expressed by Kekule's hexagon formula, thus—



The next fraction, toluene, is a homologue of benzene, and is very similar in appearance, but

boils at 111° C. Its formula is C_7H_8 , or, structurally expressed—

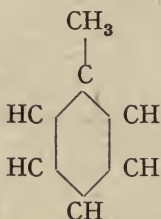

from which it will be seen that it consists of benzene in which one of the hydrogen atoms has been replaced by a methyl group (CH_3), and for this reason toluene is sometimes spoken of as methyl-benzene. Xylene, the third fraction, is another homologue of benzene, and may be called dimethyl-benzene, since it contains two methyl groups. It boils at 142° C., and has the formula C_8H_{10} , or—

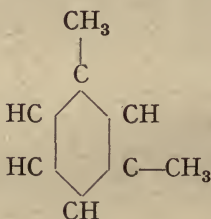

There are three forms of xylene, the form indicated by this formula being called metaxylene, which is the most important of the three.

All of the three fractions we have described are extremely important in the dye industry, as they are the basis of many of the most valuable dye-stuffs.

It has already been mentioned that the middle oil obtained by the distillation of tar is left to cool and

separate into a solid and a liquid part. The solid part which crystallises out, and is separated in a centrifugal machine, the nature of which will be seen from Fig. 5, is naphthalene, a substance having the formula $C_{10}H_8$, or—

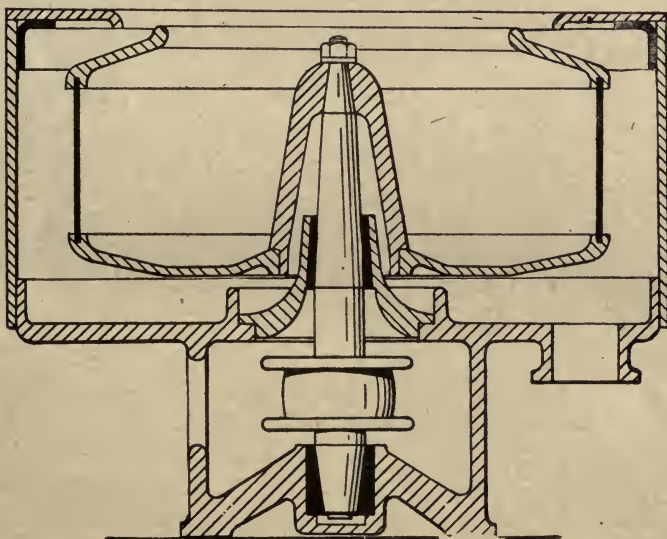
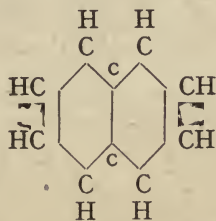

FIG. 5.

Hydro Extractor or Centrifugal.

Naphthalene is of great importance to the dye manufacturer, as it is the starting-point in the

manufacture of artificial indigo, its derivatives also being employed as constituents of many other dye-stuffs. Naphthalene is purified by being dissolved in sulphuric acid and distilled, or by sublimation.

In Fig. 6 an apparatus for subliming naphthalene is shown, the substance being placed in an iron pan heated by means of steam pipes, the naphthalene vapours passing into the large chamber, where they

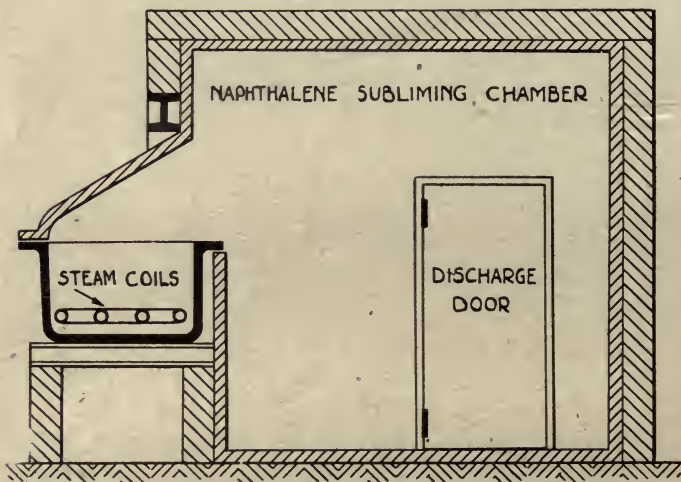
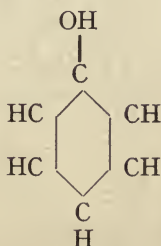

FIG. 6.

sublime on its walls, being subsequently removed through the discharge door shown. After sublimation the naphthalene is recrystallised by being dissolved in petroleum in steam-heated enamelled iron pans, to which are connected reflux condensers, so that any vapours condensed will be returned to the pans. The crystals thus obtained are freed from the solvent petroleum in a centrifugal machine and are then dried.

The liquid part of the middle oil consists largely of

phenol, or carbolic acid, which is sometimes called hydroxy-benzene because it consists of benzene in which one hydrogen atom has been replaced by an hydroxyl group (OH). It therefore has the formula $C_6H_5 OH$ or—



and when pure forms a white solid. The liquid part of the middle oil is mixed with a 10 per cent. solution of sodium hydroxide (Na OH) in order to extract the phenol, which separates with the alkaline solution as a separate layer, which is drawn off and freed from any remaining naphthalene, etc., by passing steam through it. Sulphuric acid is then added to the alkaline solution in order to neutralise it and precipitate the phenol, which is then fractionally distilled and the distillate allowed to crystallise, after which it is centrifuged in order to separate the crystallised phenol from the higher hydroxyl compounds, called cresols, with which it is mixed. Phenol is largely used in the manufacture of dye-stuffs, being frequently employed as a component in the azo dyes, which are dealt with in the next chapter.

The anthracene oils form about 15 per cent. of the tar from which they are distilled, and, as their name implies, they contain considerable quantities of anthracene, which is the substance from which the important

dye-stuff alizarin is obtained. Anthracene has the formula $C_{14}H_{10}$, or—

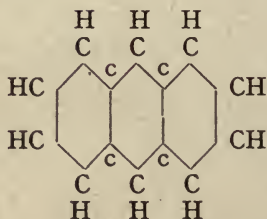

and, as its preparation is fully described in Chapter IV., it will not be necessary to give any further description of it here. It may be mentioned that the sulphuric acid washings from the light oils are subsequently treated for the recovery of ammonium sulphate and the important base pyridine; whilst the sulphuric acid washings of the heavier tar oils are treated for the recovery of quinoline, a substance used in the preparation of certain dye-stuffs.

CHAPTER III

ANILINE AND THE AZO DYE-STUFFS

THE azo dyes were discovered in 1858, and are extremely important, as they constitute the largest group of the artificial dye-stuffs. All the members of this series are characterised by the possession of an "azo-group," which is a radical consisting of two atoms of nitrogen (N_2) which can be substituted in a suitable substance for one atom of hydrogen, thus forming an azo-compound. An azo-compound which contains only one azo-group is called a monazo-compound, but many of the dye-stuffs included in this series contain more than one azo-group and are accordingly known as diazo-, triazo-, tetrakisazo-compounds, and so on, according to the number of azo-groups which they contain.

Before an intelligent understanding can be obtained of the nature of synthetic dye-stuffs it will be necessary for the reader to grasp thoroughly the reason why certain organic substances possess visible colouration. Certain substances, such as benzene, have the property of selectively absorbing light; that is to say that, according to their chemical constitution, they only absorb light waves of a certain frequency of vibration. In the case of benzene and substances of a similar character, the light waves which they are capable of absorbing are of such high frequency that they are invisible to the human eye and belong to the ultraviolet region of the spectrum.

30 ANILINE AND THE AZO DYE-STUFFS

Thus, although such substances appear to be colourless, they possess, in reality, latent or potential colour, and for this reason they are known as "chromogens."

If, now, one of the hydrogen atoms contained in benzene be replaced by a radical such as the azo-group, a substance is produced which possesses a visible colour. This is due to the fact that the azo-group reduces the rate of vibration of the chromogen molecule, thus causing it to absorb light waves of a lower frequency, which are visible to the human eye. The azo-group and other radicals having a similar action are known as chromophores, and the particular colour of the dye-stuff produced when a chromophore is combined with a chromogen depends to a great extent upon the particular chromophore employed.

The chemical structure of a molecule of most organic dye-stuffs is what is known as "quinonoid" in form; that is to say, it resembles the structure of a molecule of quinone. Quinone is a substance which contains six atoms of carbon, four of hydrogen, and two of oxygen, these being linked together and arranged in a special manner as shown in the following "ring" or "hexagon" formula—

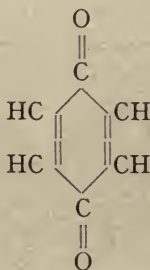

If, now, this formula be compared with that of benzene, viz.—

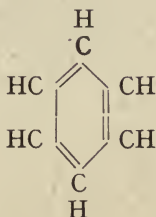

it will be noticed that there are less links or bonds between the carbon atoms in the quinone ring than in the benzene ring. In the benzene ring each carbon atom is linked to its adjacent carbon atoms by triple bonds, whilst a fourth bond links each carbon atom to an atom of hydrogen. Now carbon is a quadrivalent element, and therefore all its four valencies are satisfied in the benzene ring, which is therefore said to be "saturated." In the case of quinone, however, it will be observed that the top and bottom carbon atoms of the ring are linked to their adjacent carbon atoms by double, instead of triple, bonds. This arrangement leaves these two carbon atoms with two free valencies, or bonds, each, and thus enables them to link two atoms of a di-valent element, such as oxygen, to the ring. It is now generally considered that all derivatives of aromatic compounds which possess the properties of dye-stuffs are capable of existing in this quinonoid form, and it is because the azo-group, and other chromophores, appear to enable the chromogenic aromatic compounds to assume the quinonoid form that they are capable, with the aid of auxochromes or salt-forming groups, such as the amino (NH₂) and phenolic (OH, hydroxyl) groups, to

convert such chromogenic substances into useful dye-stuffs.

Dye-stuffs are generally either "para-" or "ortho-" compounds; that is to say, their substituted groups occupy the top and bottom positions of the hexagon in the former case, and two adjacent positions in the latter case.

Before proceeding further, it will be well to explain clearly the exact meaning of the "ring" or "hexagon" formula which occurs so frequently in expressing chemically the composition of organic dye-stuffs. Let us take benzene as an example. Benzene is the primary member of a series of substances known as the aromatic hydrocarbons, and a molecule of it is composed of six atoms of carbon and six atoms of hydrogen. These carbon and hydrogen atoms are not, however, combined in a haphazard manner, nor are they linked together, one after the other, in chain fashion, but the six carbon atoms are joined together in a closed ring which is, however, generally represented as a hexagon with one of the carbon atoms at each of its corners. Each of these carbon atoms has an attraction for each of the other carbon atoms, this attraction being represented in the formula by radial lines approaching the centre of the hexagon from its corners. This formula is called the "centric formula"; the one we have already given is, however, often used. This carbon "nucleus," as it is called, is very stable, and the hydrogen atoms are disposed around it, one of them being linked to each of the carbon atoms. This idea of the arrangement of the atoms in a benzene molecule is, of course, quite hypothetical, but it fully explains the chemical properties and behaviour of benzene and its ability to lend itself to the formation of what are called "substitution" products; and it is,

therefore, the accepted conception of the molecular structure of benzene. The hydrogen atoms in benzene are not nearly so firmly linked to the carbon atoms as the latter are to one another, and for this reason it is possible to replace them by atoms of some other substance or by "radicals," which are groups of atoms capable of acting chemically as a single atom.

When a hydrogen atom is replaced in benzene, or some other aromatic compound, the substance produced is termed a "substitution product"; and a very large number of these substitution products are artificial dye-stuffs.

The azo dye-stuffs are obtained from compounds known as "amines," owing to the fact that they contain one or more "amino-groups." An amino-group, or the amidogen radical, consists of one atom of nitrogen and two atoms of hydrogen (NH_2), and substances which contain only one of these groups are called primary amines. One of the most important of the primary amines, from the point of view of the dye-stuff manufacturer, is aniline or aminobenzene, which forms the basis of the large class of aniline dyes.

It has already been stated that benzene is a substance which contains six carbon atoms and six hydrogen atoms, and its conversion into aminobenzene or aniline simply means that an amino-group has been substituted for one of the hydrogen atoms which it contains.

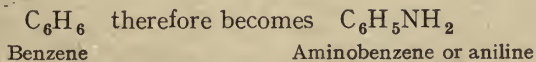

This substitution of an amino-group is not carried out directly in benzene, the first stage in the process being the nitration of the benzene; or, in other words, the

34 ANILINE AND THE AZO DYE-STUFFS

substitution of a nitro-group (NO_2) for one of the benzene hydrogen atoms.

Nitrobenzene, which has the formula—

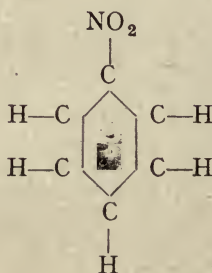

is manufactured by agitating, in an iron pan, a mixture of benzene and nitric and sulphuric acids, the sulphuric acid, however, not entering into the composition of the resulting product.

The cast-iron nitrating pan usually employed is capable of treating a charge of 500 gallons of benzene ; and, as will be seen from Fig. 7, this pan is provided with internal lead cooling coils and with a central shaft carrying two spiral agitators, the cooling coils being supported upon suitable grids. When the pan has been charged with the requisite quantity of benzene, the charge of mixed acids in the mixed acids pan is run in in a fine stream, the agitators, the speed of which is about sixty revolutions a minute, keeping the contents of the nitrating vessel constantly stirred. The mixed acids employed are made up of 6,600 lbs. of sulphuric acid (H_2SO_4) and 5,000 lbs. of nitric acid (HNO_3), which are thoroughly mixed by means of agitation with compressed air, the sulphuric acid being included in the mixture for the purpose of absorbing the water formed during the operation of nitration. While the

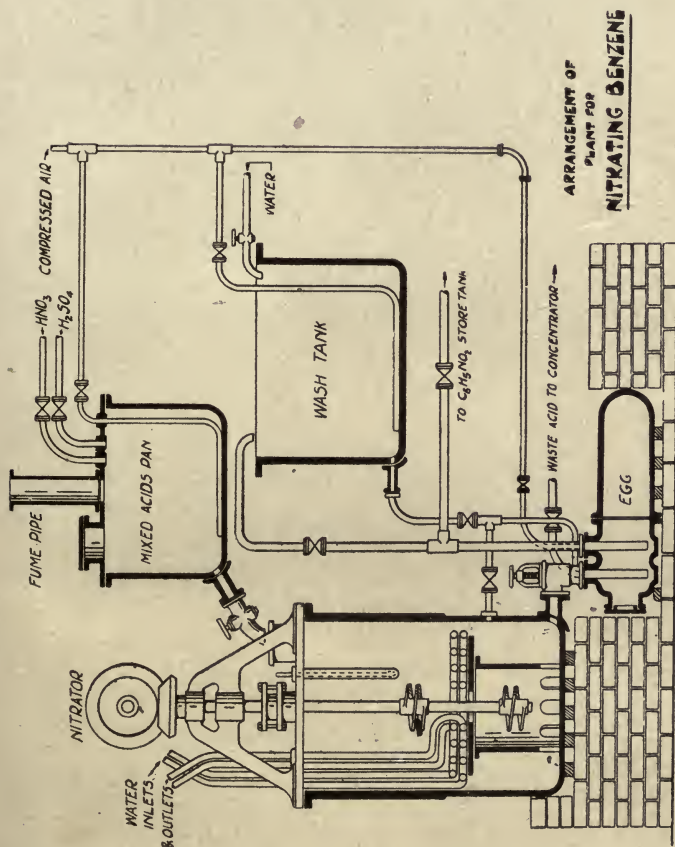

FIG. 7.

36 ANILINE AND THE AZO DYE-STUFFS

nitration is in progress the temperature of the mixture in the nitrating pan should not be allowed to rise above 60° C., and if it exceeds this at any time, the flow of mixed acids should be retarded so as to keep the temperature within the stated limit. The agitation of the mixture in the nitrating pan is continued for about four and a half hours after the charge of mixed acids has been run in, and at the end of this time the nitration is complete and the contents of the pan are left to settle for five hours.

The waste acid, which consists of diluted sulphuric acid, being heavier than the nitrobenzene, settles at the bottom and is run into an air pressure egg, from which it is forced to a concentrator, where it is reconcentrated by passing down a cascade of heated trays, and subsequently used again for making up the charge of mixed acids.

When the waste acid has been drawn off and blown to the concentrator, the nitrobenzene left in the nitrating pan is run into the egg, and is thence forced into a washing tank, where it is mixed with an equal quantity of water, to which some sodium hydroxide has been added in order to neutralise any free acid which may be mixed with the nitrobenzene, the washing being effected by well agitating the mixture by means of a jet of compressed air.

The contents of the washing tank are then left to settle for some hours, and when the nitrobenzene has settled at the bottom it is run back into the egg, from whence it is blown into store tanks prior to being converted into aniline. The wash water is afterwards run into settling tanks, from which most of the nitrobenzene still remaining in it is recovered, whilst the total yield of nitrobenzene, using the charges already mentioned, is about 154 per cent. of the quantity of

benzene employed, this being very nearly the theoretical maximum expected.

The nitrobenzene is then "reduced" and its nitro-group becomes converted into an amino-group (NH_2), thus forming the basic benzene substitution product aniline, which has the structural formula—

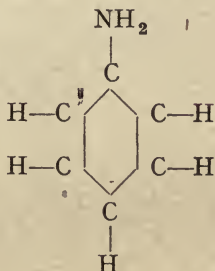

Aniline was first discovered in 1826, when it was obtained as one of the products of the distillation of indigo; but in 1834 it was found to be present in coal-tar, from which it was extracted by slaking the latter with dilute acids. Neither of the foregoing methods is now employed in practice, as it is much more convenient to manufacture aniline by the reduction of nitrobenzene, hydrochloric acid (HCl) and scrap iron being employed for this purpose.

A large cast-iron aniline pan is usually employed, having a capacity of 650 gallons and a diameter of about 4 feet 6 inches, this pan being provided with a renewable bottom and sides, this being necessary owing to the excessive wear caused by the iron used in the process. On reference to Fig. 8, which shows the arrangement of a plant for the manufacture of aniline, it will be seen that the reducing pan is also provided with a mechanically driven central shaft having

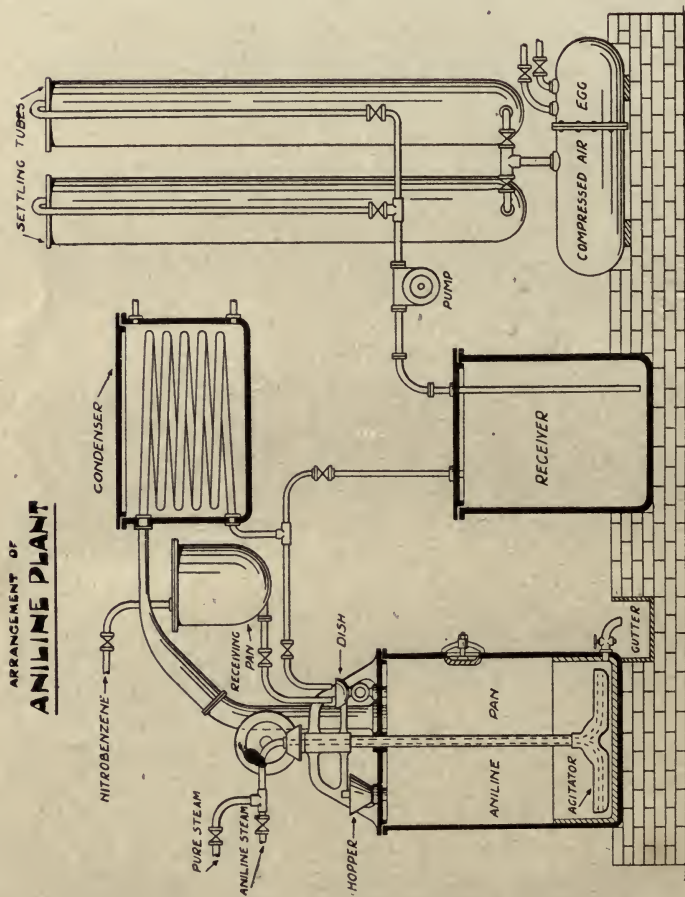

FIG. 8.

mounted upon it a pair of agitator blades which serve to keep the contents of the pan constantly stirred. This shaft is hollow and serves for the admission of the steam used for boiling the mixture to be treated, whilst on either side of the shaft are mounted a hopper, normally closed by means of a wooden plug, and a dish connected, through a stop-cock, with the interior of the vessel. There is also, connected to the cover of the aniline pan, a vapour-pipe for conducting the aniline vapour to the condenser, which is in turn connected with a receiving tank, the contents of which are pumped into settling tubes and thence into an air pressure egg, from which they are forced to the crude aniline store tanks. Above the aniline pan is arranged a receiving pan, from which a pipe connection is taken to the dish mounted on the former, to which dish a connection is also led from the condenser. A charge of 1 cwt of cast-iron borings is placed in the aniline pan through the hopper provided for this purpose, together with 6 gallons of water and 10 gallons of hydrochloric acid, whilst the receiving pan is charged with 1,000 lbs. of nitrobenzene.

Steam, which is generated from water containing from 2 to 3 per cent. of aniline, is admitted into the aniline pan and the nitrobenzene is run in through the dish in the form of a fine stream. A violent reaction occurs and distillation takes place, aniline, nitrobenzene, and water vapour being carried over to the condenser, the liquid formed being returned to the dish and thence to the reducing pan so long as its colour remains yellow, this indicating the presence of nitrobenzene.

As soon as the level of the liquid in the dish on the reducing pan becomes low, more iron borings are admitted by loosening the wooden plug in the hopper and allowing the borings which surround it to fall into

the pan, care being taken not to admit too large a quantity at one time, as, if this should happen, the reaction becomes too violent, and is liable to produce an explosion.

The admission of the full charge of nitrobenzene takes about ten hours, and the reduction is complete when the liquid returned from the condenser becomes colourless, the total quantity of iron borings used being about 9 cwt. The aniline pan now contains iron oxide, water, and aniline oil, and the next step in the process consists in the distillation of the water and aniline oil. This distillation takes about seven hours to accomplish, pure steam, instead of that generated from aniline water, being used during the last hour, and the distillate, which is composed of aniline oil and water, is diverted from the condenser into a receiver, from which it is pumped into settling tubes.

After remaining in the settling tubes for forty-eight hours, the aniline oil being heavier than water—its specific gravity being 1.026—settles at the bottom of the tubes and is run off into a steel egg, from which it is blown by means of compressed air into the crude aniline store tanks before being purified by redistillation in a vacuum still. The water remaining in the settling tubes contains about 2 per cent. of aniline, and is used again for the generation of steam for the next reduction and distillation. The yield of aniline, using the charges given, is about 760 lbs., approximately 75 per cent. of the nitrobenzene employed. Aniline is a colourless oily liquid which is easily oxidised and has a faint odour of gas lime. It boils at 184° C. and when frozen forms a crystalline mass. It is rather poisonous, and is readily soluble in acids and organic solvents, but considerably less so in water. Its presence may be detected by adding to a watery

solution of it a little bleaching soda solution, with which it gives a violet colouration, or, if it be dissolved in concentrated sulphuric acid and a drop of potassium dichromate added, a characteristic intense bluish-green colouration results.

Having considered the method of manufacturing aniline, we are now in a position to study the treatment necessary in order to produce azo dye-stuffs from it. When aniline, which it will be remembered is a primary amine, or one of its salts, such as, for instance, aniline hydrochloride ($C_6H_5NH_2HCl$) is treated at a low temperature with nitrous acid (HNO_2), or with a concentrated solution of sodium nitrite ($NaNO_2$), which has been acidified with hydrochloric acid, a reaction occurs in which the hydrogen atoms contained in the amino-group of the aniline are replaced by another nitrogen atom, which thus forms the azo-group (N_2). This process is called "diazotisation," and the resulting compound is termed a "diazocompound." If the substance mentioned above, namely, aniline hydrochloride, is diazotised, the resulting compound is diazobenzene hydrochloride, and the change which has taken place may be clearly seen by the following formulæ—

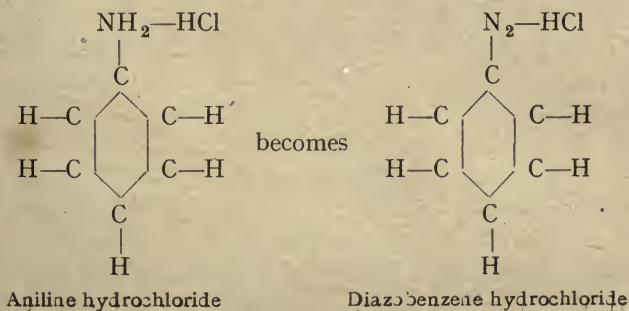

42 ANILINE AND THE AZO DYE-STUFFS

In order to produce the dye-stuff the diazotised compound is made to react with another compound, which is usually either a phenol—that is, an aromatic substance containing hydroxyl (OH), or another amino compound.

This reaction with another compound converts the diazo compound into an azo compound, the exact nature of the change being clearly seen in the following example—

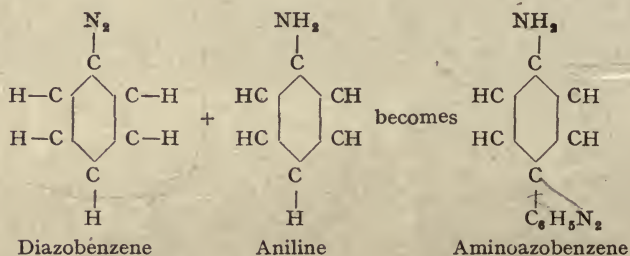

It will be observed from these formulæ that diazobenzene and aniline have been “coupled,” as it is termed, the diazobenzene, or “benzenediazo radical,” having replaced one of the hydrogen atoms of the aniline. The formula for aminoazobenzene is usually written— $\text{C}_6\text{H}_5 \cdot \text{N}_2 \cdot \text{C}_6\text{H}_4 \cdot \text{NH}_2$, but from the structural formula given above it will be seen that the benzenediazo radical ($\text{C}_6\text{H}_5\text{N}_2$) has attached itself to the carbon ring of the aniline at the opposite position to that occupied by the amino-group (NH_2), and it is therefore said to be in the “para-” position, or fourth position round the hexagon relative to the amino-group. The substance with which a diazo compound is coupled is called the “second component,” and almost any amine which has been diazotised may be coupled with another amine or a phenol, the diazo

compound almost always assuming the para-position, although, in the case of some second components, this is impossible, and the diazo compound, therefore, replaces the hydrogen at the second or "ortho-" position in the second component.

In the practical method of carrying out the process of diazotisation a solution, in water, of the amine to be treated is run into a vat provided with a mechanical stirrer, together with hydrochloric acid, the proportions being one molecular part of the amine to two and a half molecular parts of the acid. A solution of one molecular part of sodium nitrite (NaNO_2) is then run into the vat slowly, the mixture being meanwhile kept cool and agitated. When the reaction has been completed, a solution of one molecular part of the substance forming the second component is added to the diazotised amine and the mixture again agitated and warmed until the coupling has been effected; when the dye will precipitate, or may be extracted with ether or "salted out" with salt. The dye is then filtered and finally washed and dried. The diazotisation of an amine is effected by means of nitrous acid (HNO_2), but, in practice, sodium nitrite is always used and the nitrous acid generated in the solution by means of hydrochloric acid, as this method facilitates the reaction.

The solution of the second component which it is desired to couple to a diazo compound is varied according to the nature of such second component, that is to say, if the second component is an amine its solution is acidified by means of acetic or hydrochloric acids, or else rendered neutral; but if it is a phenol its solution is made alkaline by the addition of sodium carbonate.

The process of diazotisation and coupling has a very

wide and extensive application, and it has already been mentioned that substances produced in this manner form the largest group of artificial dye-stuffs known. It will therefore only be possible, in a work of this kind, to give a few examples of the actual dye-stuffs, especially as the already large list of these is frequently being added to by the synthesis of new compounds. But if the reader has thoroughly mastered the explanation in the foregoing pages of the methods employed in the production of these dyes, and the general chemical nature of the substances which form their basis, he will be in a position to understand the nature and manufacture of almost any of the series of azo dyes.

Aminoazobenzene, the composition of which we have already considered, is a crystalline substance having an orange colour, and when combined with oxalic acid ($\text{COOH} \cdot \text{COOH}$) forms an oxylate which is the dye-stuff known as **Aniline Yellow**. Aniline yellow is a typical azo dye, capable of dyeing wool and silk directly and cotton after treatment (mordanting) with stannic (tin) tannate, the colour produced, however, being dull and not very fast to light.

Acid Yellow, which is a faster and better colour than aniline yellow, is produced by sulphonating aminoazobenzene, the chemical name of this dye being aminoazobenzene disulphonic acid. Sulphonation is a process which consists of treating an organic substance with sulphuric acid (H_2SO_4), and thus introducing into it a "sulphonic" group (SO_3H). Strong concentrated or "fuming" sulphuric acid is employed, and this, together with the substance to be sulphonated, is heated in an agitated vat until the reaction is completed.

In the substance we are considering, namely, amino-

azobenzene disulphonic acid, two sulphonic groups have been substituted for two hydrogen atoms, and this compound, therefore, has the formula—

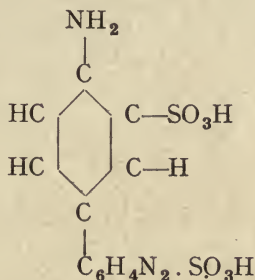

or—

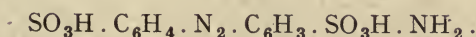

In the preparation of this substance three to five parts of acid are used to every part of aminoazobenzene, and it will be seen from the formula that one of the sulphonic groups enters each of the two components of the azo compound. Sulphonic acids, in common with all other acids, have the property of forming "salts" with bases, and the actual composition of the dye-stuff known as Acid Yellow is a mixture of the sodium (Na) salts of the mono- and disulphonic acids of aminoazobenzene.

A similar dye, which is, however, deeper and more orange in colour, and is known as **Fast Yellow B.**, is obtained from the corresponding compound of toluene, namely aminoazotoluene disulphonic acid, toluene being a substance homologous to benzene and containing, in its molecule, seven atoms of carbon and eight of hydrogen, one of the former and three of the latter being united to form a "methyl" group (CH_3), which is attached to the "six carbon ring" or nucleus.

Many important azo dye-stuffs are derived from

46 ANILINE AND THE AZO DYE-STUFFS

naphthalene, which is a substance similar in many respects to benzene, but having a more complex structure. Naphthalene ($C_{10}H_8$) has a molecular structure consisting of two benzene rings linked together, the two middle carbon atoms being common to both rings, as will be seen from the formula—

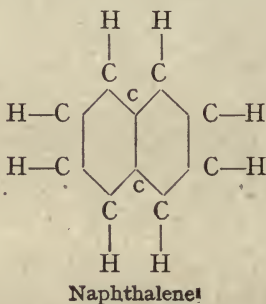

Owing to this structure, the substitution products of naphthalene are more numerous than those of benzene, and there are two sets of mono-substitution products, these being distinguished by the prefix "alpha," written " α ," and "beta," written " β ." The following formula will make this clear—

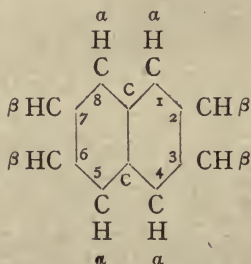

If, for instance, an amino-group is substituted for a hydrogen atom at one of the positions marked " α ," the

resulting amine is called α -naphthylamine, but it is also possible for the amino-group to be attached at one of the β positions, thus forming β -naphthylamine.

Naphthylamine, like aniline, can be diazotised, nitrated, or sulphonated, and the acid wool dye known as **Fast Red A** is produced by its sulphonation. The actual dye-stuff consists of α -naphthylamine-sulphonic acid, $C_{10}H_6(SO_3H) \cdot NH_2$ (α), usually known as naphthionic acid, coupled with β -naphthol, $C_{10}H_7 \cdot OH$ (β), which is the naphthalene derivative corresponding to phenol. The α -naphthylamine-sulphonic acid is made by treating α -naphthylamine with sulphuric acid at a temperature of $130^\circ C.$, the coupling with β -naphthol being effected in a manner similar to that described in connection with aminoazo-benzene.

Palatine Red is another naphthalene dye-stuff, being composed of α -naphthylamine—

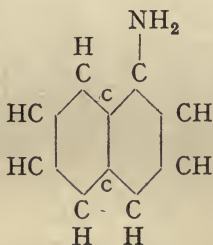

coupled with 1 : 3 : 6-naphthol disulphonic acid—

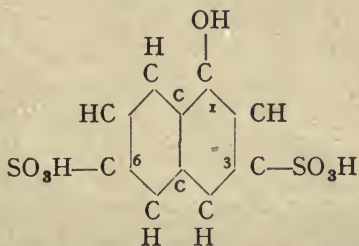

48 ANILINE AND THE AZO DYE-STUFFS

Lanacyl Blue BB., which is an acid wool dye, consists of 1 : 8 : 3 : 6-aminonaphthol disulphonic acid—

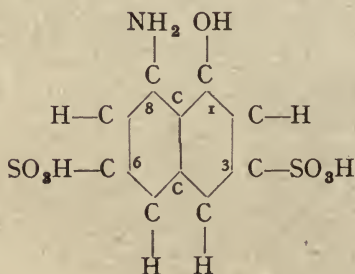

coupled with 1 : 5-aminonaphthol—

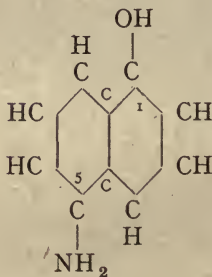

There are a number of dyes used for dyeing wool which has been chrome-mordanted, but the following three examples will suffice, although there are a number of more complex dyes of this character which are obtained from *o*-aminophenols which have been diazotised, these being the subject of recent patents.

Azochromine is a combination of *p*-aminophenol—

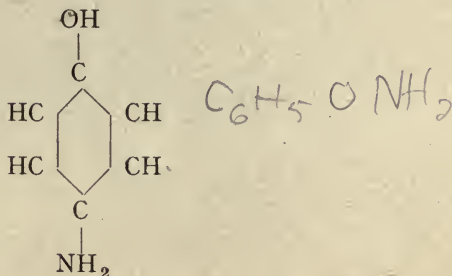

and pyrogallol, or *v*-trihydroxybenzene, which has the formula—

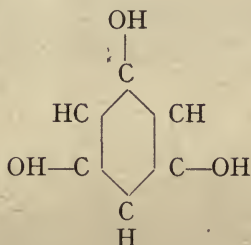

Diamond Yellow R. consists of anthranilic acid, which is the name given to *o*-aminobenzoic acid—

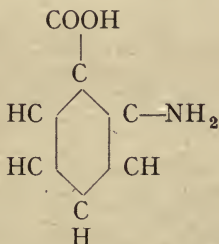

coupled with salicylic acid, which is a substance manufactured from anthranilic acid, and has the

50 ANILINE AND THE AZO DYE-STUFFS

formula $C_6H_4(OH) \cdot COOH$, the hydroxyl-group being substituted for the amino-group contained in anthranilic acid.

Azofuchsine B. is made up of toluidine, the toluene derivative corresponding to aniline, the para-compound having the formula—

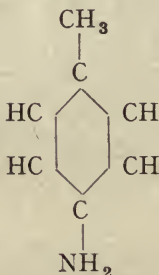

being generally used, coupled with 1:8:4-dioxy-naphthalene sulphonic acid—

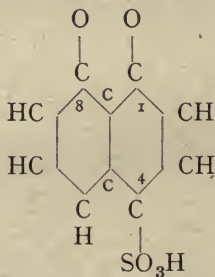

Another class of dyes consists of those used in manufacturing "lakes," which are combinations of dye-stuffs and mordants, a mordant being a substance employed to precipitate the colouring matter in the fibres of the fabric to be dyed.

A good example of this class of dye-stuffs is **Lithol**

Red, this being a combination of 2-naphthylamine-1-sulphonic acid—

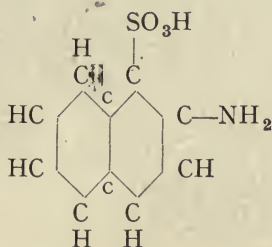

and β -naphthol, which has the formula—

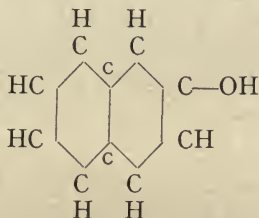

Amongst the monazo dyes there are a number of compounds forming a series of Direct Cotton Dyes—that is, dyes which are capable of dyeing cotton which has not previously been mordanted. These are produced by derivatives of 2:5:7-aminonaphthol sulphonic acid, when coupled with a diazo compound such as aniline or naphthylamine, and also by diazotised primuline in combination with an amine or other suitable component.

These direct, or “substantive dyes,” as they are called, are very important, as, by reason of the colour being formed within the fibres themselves, the dye imparted to the fabric is very fast to light and washing. Primuline forms the basis of many of the most valuable

of these dye-stuffs, and it is therefore important to understand the chemical nature and manufacture of this substance. If a quantity of para-toluidine, or aminotoluene, which is the amino derivative of toluene corresponding to aniline, is heated with an excess of sulphur, some of the hydrogen of the *p*-toluidine combines with the sulphur to form hydrogen sulphide, whilst some of the sulphur combines with the dehydrogenated *p*-toluidine, which is then said to be "thionated." The products of this reaction, then, are hydrogen sulphide and dehydrothiotoluidine, the latter being a yellow crystalline substance, having basic properties, which is soluble in alcohol, but not in water. If, now, dehydrothiotoluidine is heated with a further quantity of sulphur, the reaction is carried farther and higher condensation products result, these being known as "primuline bases," as on being sulphonated they yield primuline.

The manufacture of primuline is carried out in its primary stage, namely, the production of the primuline base, in an enamelled iron melt-pot provided with a mechanical agitator and a condensation pipe, as shown in Fig. 9. This pot is charged with 1,000 lbs. of *p*-toluidine and 670 lbs. of sulphur, which are heated to boiling-point and constantly agitated for some hours, the hydrogen sulphide evolved being conducted to an iron box, where any *p*-toluidine carried over with it collects, and is then burnt to assist the heating of the melt-pot.

When the evolution of sulphuretted hydrogen ceases the agitator is stopped and a discharge pipe is inserted in the charge hole of the melt-pot, through which the condensation product is removed by means of air pressure.

After removal from the melt-pot, the product is

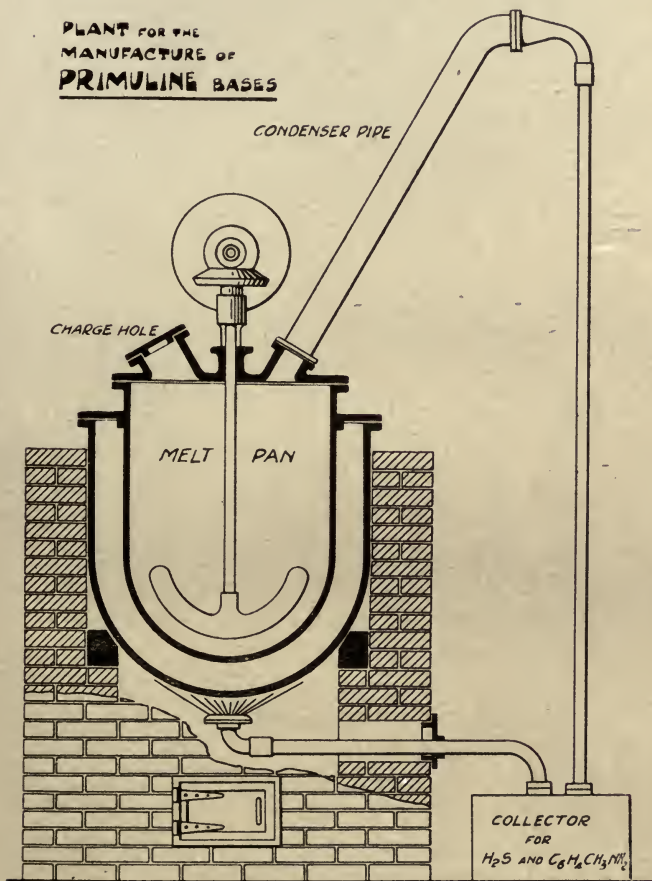

FIG. 9.

54 ANILINE AND THE AZO DYE-STUFFS

ground to powder form, and 400 lbs. of it are placed in a sulphonation pan provided with cooling coils and an agitator, as shown in Fig. 10, where it is mixed with

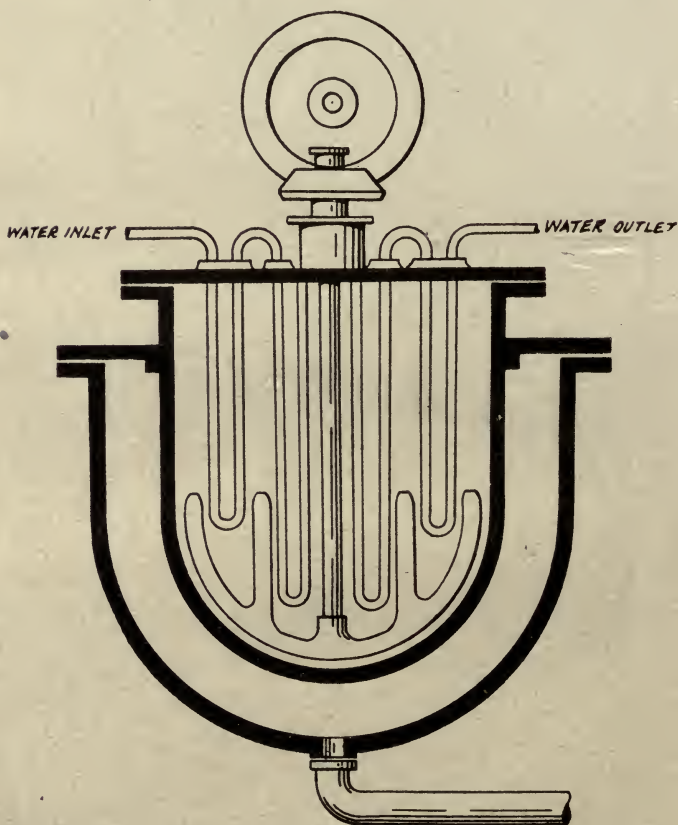

FIG. 10.

1,000 lbs. of sulphuric acid and dissolved by agitation. When the solution is complete, 800 to 900 lbs. of sulphuric acid containing 70 per cent. of SO_3 are run

in slowly, the mixture being constantly agitated and the temperature kept below 40° C. In about six hours the sulphonation is completed, and this may be verified by testing a sample from the sulphonation pan by precipitation in water, to which boiling dilute ammonia is added, when the precipitate should dissolve, leaving a clear solution.

Compressed air is then admitted into the sulphonation pan, and its contents blown out through the hollow shaft of the agitator, being then run into a vat which contains 3,000 gallons of cold water. A profuse orange-yellow precipitate, consisting of dehydrothiitoluidine and primuline sulphonic acids, forms in the water, and this is washed and filtered in a filter-press, where any traces of mineral acid still remaining in it are removed. When this operation is finished, the primuline sulphonic acid is separated out and mixed with sodium chloride (common salt) in order to standardize its strength.

Commercial primuline is the sodium salt of the mono-sulphonic acid of the primuline bases, or higher condensation products of the action of sulphur on *p*-toluidine, and the yield of standard primuline from 1,000 lbs. of *p*-toluidine is about 1,700 to 1,800 lbs.

Dehydrothiitoluidine, the substance first formed when sulphur reacts with *p*-toluidine, has the composition $C_{14}H_{12}N_2S$, the arrangement of the atoms in the molecule being according to the structural formula—

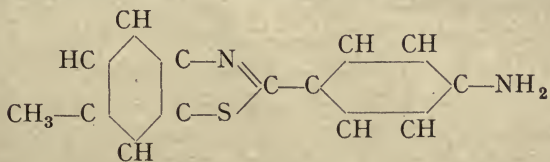

The higher condensation products, or primuline

bases, are simply di- and tri-thionated compounds, or, more correctly speaking, they contain respectively two and three chromophoric groupings, and therefore have the following formulæ—

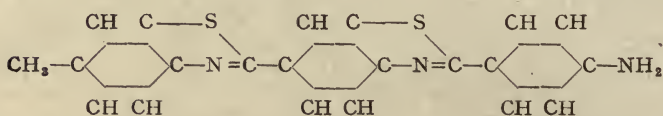

or—

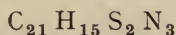

and—

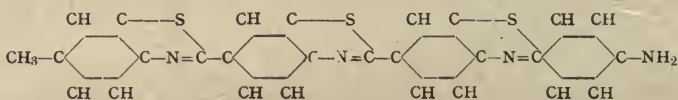

or—

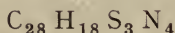

As will be seen from the foregoing formulæ, only one amino-group is present in the thionated products of *p*-toluidine, and therefore in their sulphonic acids. These latter, however, form soluble alkaline salts which dye unmordanted cotton a primrose yellow, the fabric so dyed being afterwards treated with a dilute solution of nitrous acid, or hydrochloric acid and sodium nitrite, in order to diazotise the amino-group of the compound. This diazotisation does not in any way lessen the degree in which the compound combines with the fibres of the fabric, and when it has been carried out, the fabric is then immersed in a bath consisting of a solution of an amine or a phenol, the latter being thus coupled to the diazotised compound, and thus developing the dye in the fibres. By carrying out this process with various components a whole

series of fast dyes can be produced, their colours ranging from reddish-yellow to violet.

Oriol Yellow is a typical example of this class of dye-stuff, being obtained by diazotising primuline and coupling with salicylic acid ($C_6H_4(OH)COOH$).

Erica B. is an important, fast, and brilliant pink dye-stuff which is obtained by coupling diazotised dehydrothioxyldine, having the formula—

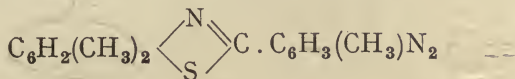

with the sodium salt of α -naphthol 3 : 8-disulphonic acid, which has the formula $C_{10}H_4(OH)(SO_3Na)_2$.

Rosopenine IO B. consists of dehydrothiotoluidine sulphonic acid coupled with 1-naphthol-4-sulphonic acid.

Ingrain, or Primuline Red, is produced by dyeing the fabric with primuline, diazotising its amino-group and developing in a bath of β -naphthol.

Ingrain Orange is produced in the same manner, using resorcinol ($C_6H_4(OH)_2(m)$), however, instead of β -naphthol.

Ingrain Brown is another of the Ingrain series of colours, this being produced by the use of a developing bath of meta-phenylenediamine ($C_6H_4(NH_2)_2(m)$). This dye is also known as Alkali Brown (D.), Benzo Brown (5 R.), Cotton Brown (R.), and Terra-cotta (G.). In addition to the process by which the foregoing dyes are produced, another process is also used, namely, that of dyeing the fabric with primuline, or dehydrothiotoluidine sulphonic acid, and then oxidising by means of a solution of sodium or calcium hypochlorite. By this method valuable fast direct dyes can be produced which are chiefly yellow in colour.

A substance which is of great importance, and which is widely used in the production of dyes which develop on the fibre, is β -naphthol, the composition of which has already been given. The fabric is "padded," as it is termed, with this substance before being immersed in the dye bath, one of the most important of the colours produced by this method being **Para-nitraniline Red**. In the production of this colour the fabric to be dyed is first placed in a bath consisting of an alkaline solution of β -naphthol, or a solution of sodium β -naphoxide, and *p*-nitraniline ($C_6H_4(NO_2) \cdot NH_2(p)$), at a temperature of from 65° to 80° C, and is then treated with a diazotising solution, being subsequently soaped and washed.

Azo Turkey Red is produced in a similar manner, using diazotised β -naphthylamine instead of diazotised *p*-nitraniline. It gives a bright scarlet colour which, however, is rather fugitive.

Thus far we have considered only dyes of the monazo-group, that is, dyes which are produced by coupling a diazo compound with a second component consisting of an amine or a phenol, and we must now turn to the consideration of Disazo dyes. Disazo dyes may be divided into three classes, according to the method of their production, but they will be quite easy to understand if it is remembered that all of them contain two azo-groups.

Primary disazo dyes are made by diazotising two different amines or two molecular proportions of the same amine, and then linking together the two diazo compounds thus produced by means of a suitable component.

A typical example of this type of dye is **Terracotta F.**, which consists of diazotised primuline and diazotised naphthionic acid ($C_{10}H_6(SO_3H) \cdot N_2$) linked

or coupled together by *m*-phenylenediamine ($C_6H_4(NH_2)_2(m)$), this being a direct cotton dye.

Cotton Orange R. consists of diazotised primuline and diazotised metanilic acid coupled together by *m*-phenylenediamine sulphonic acid.

Fast Brown is an acid wool dye, and is made by diazotising two molecular proportions of naphthionic acid and linking together the resulting compounds with resorcin ($C_6H_4(OH)_2$).

Resorcin Brown is made by diazotising *m*-xylydine, which is the amino derivative of xylene ($C_6H_4(CH_3)_2$), and coupling the resulting diazo compound with diazotised sulphanilic acid by means of resorcin.

These examples will suffice to show the nature of the primary disazo dyes. The *secondary* disazo dyes are made by diazotising aminoazo compounds and coupling the products with suitable amino or phenolic components. The first stage in the process is the diazotisation of an amino compound, which is then combined with another amino compound, usually called the middle component, the amino group of this middle component being then diazotised and the product coupled with an amine or phenol. The amines usually employed as middle components, when combined with a diazo compound, form para-aminoazo compounds, that is to say, the amino-group adopts the para- or fourth position round the hexagon relative to the azo-group, or, alternatively, the amino-group attaches itself to a different ring from the one to which the azo-group is attached, the amino-group of the aminoazo compounds thus formed being readily diazotisable in consequence of this arrangement.

The nature and method of production of this class of dye-stuffs will be readily understood by the consideration of the few following examples.

Cloth Red G. is produced by diazotising aminobenzene, or aniline, the diazo compound thus produced being coupled with aminobenzene and again diazotised, and finally coupled with α -naphthol-4-sulphonic acid in an alkaline bath.

Biebrich Scarlet consists of diazotised aminoazobenzene coupled with β -naphthol.

Cloth Scarlet G. is made by diazotising aminoazobenzene sulphonic acid and coupling the resulting product with β -naphthol. This is an acid wool dye.

Fast Violet R. is produced by coupling together diazotised sulphanilic acid and diazotised α -naphthylamine with β -naphthol sulphonic acid S.

Jet Black R. consists of diazotised disulphonic-benzenazo- α -naphthylamine $((\text{SO}_3\text{H})_2\text{C}_6\text{H}_3\text{N}_2 \cdot \text{C}_{10}\text{H}_6\text{N}_2)$ coupled with phenyl- α -naphthylamine $(\text{C}_{10}\text{H}_7\text{NH} \cdot \text{C}_6\text{H}_5)$. This gives a bluish-violet solution in water, and dyes a jet black.

Naphthylamine Black D., which is an acid wool dye, is made by coupling two diazotised proportions of α -naphthylamine with naphthylamine disulphonic acid.

Croceine Scarlet 7 B., which is another acid wool dye, consists of aminoazotoluene sulphonic acid which has been diazotised, and 2 : 8-naphthol sulphonic acid.

Brilliant Croceine M., also an acid wool dye, is produced by coupling 2 : 6 : 8-naphthol disulphonic acid with diazotised aminoazobenzene.

Ponceau 4 RB., a scarlet dye suitable for wool or cotton, consists of diazotised aminoazobenzene sulphonic acid coupled with 2 : 8-naphthol sulphonic acid.

There is yet another class of disazo dyes in addition to those already mentioned, namely, disazo dyes which are obtained from tetrazotised diamines, the majority of which are substantive dyes, and therefore dye unmordanted cotton.

Dyes of this class consist of primary diamines in which both the amino-groups have been diazotised, thus forming a tetrazo compound, coupled with two molecular proportions of a second component to form a "symmetrical" disazo dye, or with one molecular proportion of two different components, thus forming a "mixed" disazo dye.

One of the most important of the diamines employed in the production of disazo dyes is benzidine or *p*-diaminodiphenylene, the molecular structure of which consists of two benzene rings linked together, each ring containing an amino-group in the para-position—

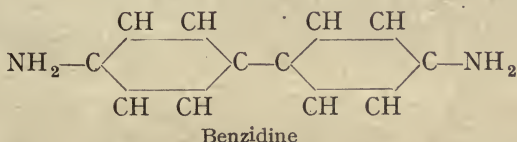

A number of other diamines of a similar type are also employed, among which are dianisidine, benzidine-*o*-disulphonic acid, *o*-tolidine, diethoxybenzidine, and diaminostilbene disulphonic acid, most of these diamines having the amino-groups in para-positions.

A few examples of dyes obtained from various diamines will make their nature clear.

Benzopurpurine 4 B. is a scarlet direct cotton dye which consists of tetrazotised tolidine, which is the derivative of toluene corresponding to benzidine, coupled with two molecular proportions of naphthionic acid.

Benzopurpurine 10 B. is a similar dye-stuff obtained by tetrazotising dianisidine and coupling the resulting disazo compound with two molecular proportions of

naphthionic acid, thus forming a "symmetrical" dye.

Congo Red, which is the prototype of a series of "Congo dyes" derived from benzidine, consists of tetrazotised benzidine coupled with two molecular parts of naphthionic acid. In practice the sodium salt is used having the formula—

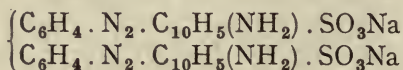

and this is a scarlet powder imparting a reddish-brown fast colour to cotton.

Congo Blue 2 B is made by coupling tetrazotised dianisidine with 1-naphthol-4-sulphonic acid, and 2-naphthol-3 : 6-disulphonic acid, this being therefore a "mixed" disazo dye.

Congo Red 4 R. consists of tetrazotised tolidine, naphthionic acid and resorcin.

Congo Corinth B. consists of tetrazotised tolidine, and this is coupled with two molecular proportions of 1-naphthol-4-sulphonic acid.

Diamine Blue BB. is made by coupling tetrazotised benzidine with two molecular parts of 1 : 8 : 3 : 6-amino-naphthol sulphonic acid, the coupling being effected in alkaline solution.

Diamine Red 3 B. or **Deltapurpurine 7 B.** consists of tetrazotised tolidine, to which is coupled 2-naphthylamine-7-sulphonic acid in the requisite molecular proportions.

Oxamine Red is a mixed disazo dye made by coupling tetrazotised benzidine with one molecular part of salicylic acid and one molecular part of 2 : 5 : 7-aminonaphthol sulphonic acid in alkaline solution.

Bismarck Brown or **Manchester Brown** consists of

tetrazotised *m*-phenylenediamine coupled with two molecular proportions of *m*-phenylenediamine—

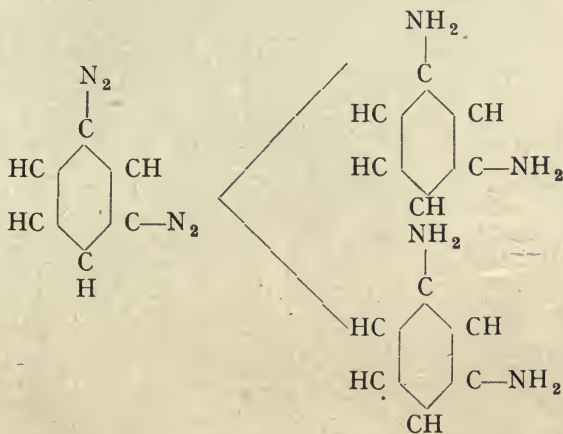

This is a direct wool and leather dye, and it also dyes cotton when the latter is mordanted with tannin.

Naphthylene Red, a substantive dye, is composed of tetrazotised 1:5-diaminonaphthalene coupled with two molecular parts of naphthionic acid.

Brilliant Yellow is made by tetrazotising diamino-stilbene disulphonic acid and coupling the product with the necessary molecular proportions of phenol—

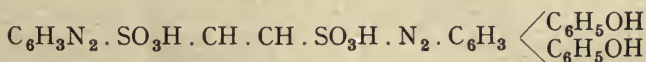

Hessian Yellow is similar to the preceding dye-stuff, salicylic acid being used, however, instead of phenol, as the second component.

We have now to consider the Trisazo Dyes, that is, dyes which contain three azo-groups, and the methods

by which they are produced, the first of these methods being from secondary disazo dyes. It will be remembered that a secondary disazo dye consists of a diazotised amine coupled with an amine known as the middle component, which is itself in turn diazotised, and coupled with an end component, which may be either an amine or a phenol. If this end component is an amine its amino-group may also be diazotised, and coupled with another component, thus producing a trisazo dye.

An example of a trisazo dye produced in this way is—

Janus Brown B., which is produced by diazotising *m*-aminophenyltrimethylammonium chloride, coupling the product with α -naphthylamine, diazotising again, and finally coupling with chrysoidine. The dye has the formula—

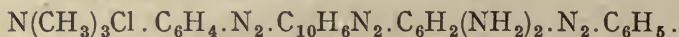

Sometimes the end component of a secondary disazo dye possesses the property of "double coupling," in which case a further diazo compound may be coupled to it. This class of dye-stuffs is illustrated by the following examples.

Diamine Green B. consists of tetrazotised benzidine coupled with phenol, the product being then combined with the colouring matter produced by coupling diazotised *p*-nitraniline with 8-amino- α -naphthol-3:6-disulphonic acid.

Diphenyl Green G. is similar to Diamine Green B.; in this dye, however, *o*-chloro-*p*-nitraniline is employed instead of *p*-nitraniline.

Another way of obtaining trisazo dyes is from tetrazotised diamines. By this method benzidine, or some other tetrazotised diamine, is combined with a middle component containing a diazotisable amino-group, to

produce an intermediate product which is afterwards diazotised and forms a tetrazo compound, which is coupled with two molecular parts of an end component.

Congo Fast Blue B. is produced in the above way by tetrazotising dianisidine and coupling the product with α -naphthylamine, the intermediate compound thus formed being diazotised and coupled with two molecular proportions of 1-naphthol-3 : 8-disulphonic acid. Instead of the end component consisting of two molecular parts of one substance it may consist of one molecular part of two different substances.

Trisazo dyes are also formed by making a "mixed" disazo dye, consisting of a tetrazotised diamine, one molecule of a diazotisable middle component, and a molecule of a second component. The middle component is diazotised, and the product coupled to an end component.

Benzo Grey is produced in this way by tetrazotising benzidine and coupling with α -naphthylamine and salicylic acid, the α -naphthylamine being then diazotised and coupled with 1-naphthol-4-sulphonic acid.

Diamine Beta Black is another of this class of dye-stuffs, and consists of tetrazotised benzidine coupled with 1 : 8 : 3 : 6-aminonaphthol disulphonic acid and *p*-xylidine which is then diazotised and coupled with 1 : 8 : 3 : 6-aminonaphthol disulphonic acid.

Diamine Green G. is produced by another method, which consists in diazotising *p*-nitraniline and coupling the product with 1 : 8-aminonaphthol-3 : 6-disulphonic acid in acid solution. The substance thus produced is a monazo dye which is coupled in alkaline solution with the intermediate product produced by combining tetrazotised benzidine with salicylic acid, thus producing a direct cotton green dye. This dye-stuff is typical of a series of dyes produced in a similar manner.

Several other methods are employed for producing trisazo dyes; for instance, three molecules of a diazo compound may be combined with 1:8:4-aminonaphthol sulphonic acid to produce a dye; or a primary disazo dye, containing as one of its components either acetyl-*p*-phenylenediamine, or *p*-nitraniline, may be treated, by saponification in the case of the former, and reduction in the case of the latter, so as to form an amino-group which is then diazotised and coupled with a suitable component. Triamines may also be diazotised, and made into dyes by coupling with three molecular parts of a suitable component, a typical example being **Alizarin Yellow FS.**, which consists of diazotised magenta ($C_{20}H_{20}N_3Cl$), or rosaniline chloride, coupled with three molecules of salicylic acid.

Tetrakisazo Dyes, as their name implies, contain four azo-groups, and they are produced by a variety of methods. Their composition is easily understood if they are regarded as trisazo dyes, the end component of which contains a diazotisable amino-group, the product after the diazotisation of this amino-group being coupled with a suitable component, thus forming a tetrakisazo dye.

A few examples will suffice to show the general character of these dyes.

Benzo Brown G. is the compound resulting from the action of two molecules of diazotised sulphanilic acid ($C_6H_4 \cdot N_2 \cdot SO_3H$) on one molecule of Bismarck Brown (tetrazotised *m*-phenylenediamine coupled with two molecular proportions of *m*-phenylenediamine). It has the formula—

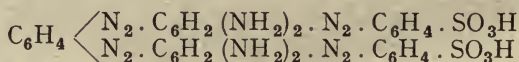

and gives a reddish-brown solution in water.

Toluylene Brown R. is produced in a similar manner, by the action of two molecules of diazotised naphthionic acid on the colouring matter produced by coupling tetrazotised 2 : 6-tolylenediamine-4-sulphonic acid with two molecular parts of *m*-phenylenediamine.

Hessian Brown BB. is the product of the action of a monazo dye, produced by coupling diazotised sulphanic acid with resorcinol, on tetrazotised benzidine.

Mekong Yellow G. is made by combining two molecular parts of tetrazotised benzidine with two molecular parts of salicylic acid, the intermediate compound thus produced being coupled with dihydroxydiphenylmethane. This composition may be shown thus—

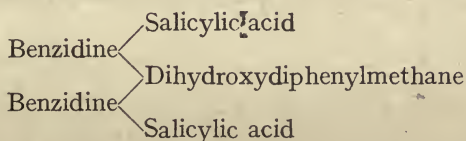

There is yet another class of azo dye-stuffs, and this is composed of what are known as Stilbene Dyes.

Stilbene, or diphenylethelene, has the formula $\text{C}_6\text{H}_5 \cdot \text{CH} : \text{CH} \cdot \text{C}_6\text{H}_5$, and the dyes to which this substance gives its name contain what is called a stilbene residue (CH). The dyes of this series are produced by condensing with alkali and oxidising *p*-nitrotoluene sulphonic acid, the first result of this action being the production of dinitrostilbene sulphonic acid—

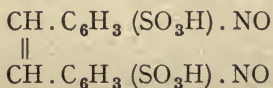

One of the molecules of this substance is oxidised by means of the oxygen of the second molecule—

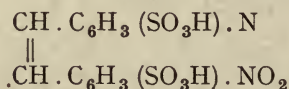

and the free nitrogen atom thus remaining in the molecule combines with a similar nitrogen atom in another molecule to form an azo-group, a molecule of the resulting compound being known as a distilbene molecule.

Stilbene Yellow 8 G. is a greenish-yellow substantive dye composed of dinitroazodistilbene disulphonic acid having the formula—

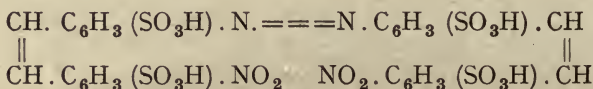

which is prepared in the manner we have described by the alkaline condensation of *p*-nitrotoluene sulphonic acid and oxidation.

Orange and reddish-yellow shades are obtained from the above substance by reducing the nitro-groups (NO_2) which it contains to an azoxy or an azo-group.

Chicago Orange RR. is produced by the condensation of *p*-nitrotoluene sulphonic acid with benzidine and sodium hydroxide (NaOH), the resulting compound giving an orange-yellow solution in water.

Mikado Yellow L. is made by oxidising, with suitable agents, the condensation products of sodium hydroxide and *p*-nitrotoluene sulphonic acid.

Arnica Yellow G., which is a direct cotton dye, is made by condensing *p*-nitrotoluene sulphonic acid together with *p*-aminophenol in a boiling solution of sodium hydroxide in water.

Curcuphenine, a yellow dye, is made by condensing *p*-nitrotoluene sulphonic acid with dehydrothio-*p*-toluidine sulphonic acid, the nature and manufacture of which has already been explained, in the presence of a dilute solution of sodium hydroxide in water.

There are a number of other stilbene dyes, amongst which may be mentioned Mikado Orange, Sun Yellow, Diphenyl Orange RR., and Stilbene Yellow, but the examples already given are sufficient to make their general character clear, and the reader is referred to the larger text-books for an exhaustive list of the large number of azo dyes now made.

CHAPTER IV

THE ANTHRACENE DYES

As described in a previous chapter, anthracene is obtained entirely from the heavy coal-tar oils which boil at a temperature above 300° , and constitute the "last runnings" of the tar distiller. These heavy oils after redistillation are cooled, and the anthracene oils collected as the distillate solidifies. The anthracene at this stage is a greenish semi-solid substance, and after treatment in hydraulic presses to free it from excess of oil, it forms the raw material for the manufacture of alizarin.

Alizarin is one of the oldest and most important dyes, and, before its production from coal-tar, was obtained from madder root, in which it occurs naturally. Artificial alizarin was first prepared by Graebe and Liebermann in the year 1868.

The first operation necessary before the actual production of alizarin can commence is that of purifying the crude anthracene obtained from the tar distillers, which rarely contains more than 40 per cent. of anthracene, the remainder consisting of phenanthrene, naphthalene, carbazol, and small quantities of other hydrocarbons.

According to one well-known process, about 1,500 to 1,800 lbs. of crude anthracene are, after grinding between edge runners, boiled with 300 gallons of petroleum spirit in large steam-heated iron vessels fitted with mechanical stirring apparatus. The boiling is

continued for from one to two hours, and the product is cooled, filtered through coarse canvas, washed with clean petroleum spirit, and sublimed. A plant suitable for subliming anthracene is shown in Fig. 11. The anthracene is disposed to a depth of two or three inches in a shallow iron pan, heated from below by a furnace. By means of a perforated pipe, superheated steam is introduced above the pan, to carry away the vapours through the outlet into a large chamber, where they are suddenly chilled by a spray of cold water from the rose, the anthracene being thereby precipitated in the finest state of division, which condition is necessary for its subsequent easy conversion into anthraquinone by the action of oxidising agents.

Anthracene can also be obtained in the form of colourless crystalline plates, and has the formula $C_{14}H_{10}$, its constitution being better indicated, however, by the structural formula—

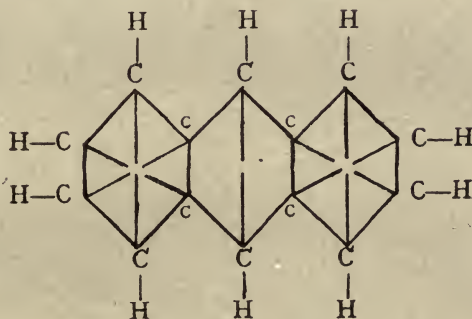

This formula indicates that a molecule of anthracene contains three rings, linked together, the para-atoms of the middle ring being shown linked together as they form groups having a ready oxidability. Having

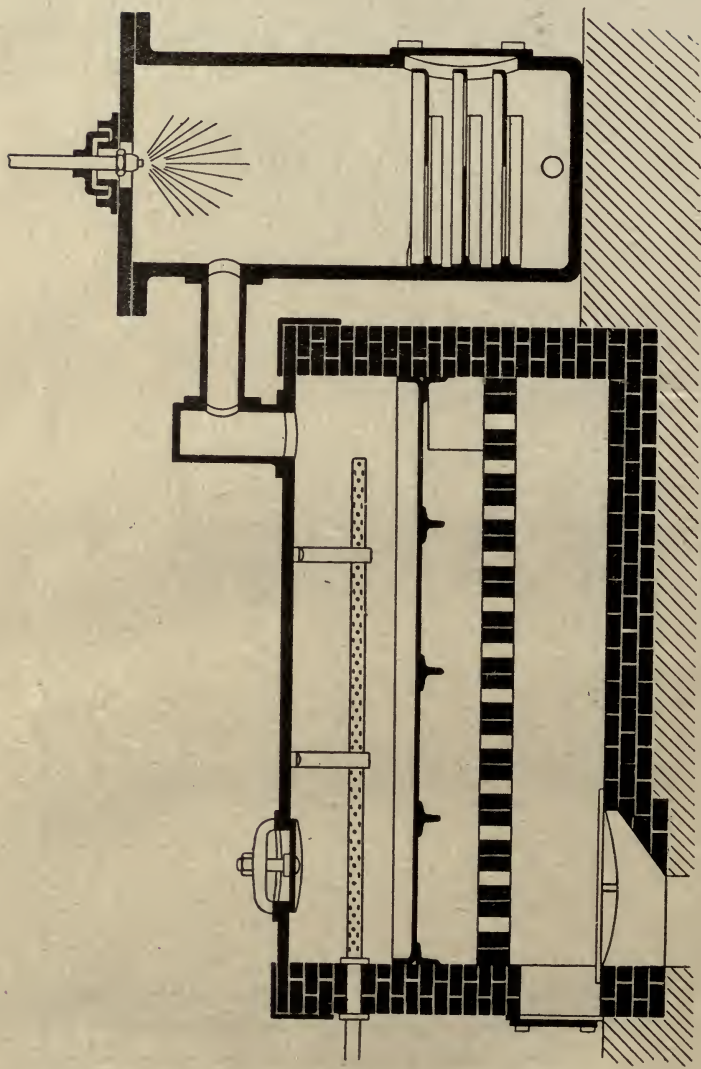

FIG. 11.—Anthracene Subliming Plant.

purified the anthracene, it is possible to proceed with the manufacture of alizarin.

The following description of one well-known process will be better understood by reference to Fig. 12, in which the plant used is diagrammatically set out.

The first step in the manufacture of alizarin consists in oxidising the finely divided anthracene into anthraquinone. This operation is carried out by placing a quantity of anthracene in lead-lined tanks with twice its weight of bichromate of potash or soda dissolved in water. Dilute sulphuric acid is slowly added, and the whole mass boiled and kept in a state of constant agitation by means of a jet of steam from an injector. The product is transferred to settling tanks, and the crude yellowish-brown anthraquinone washed from the green chrome liquors, being finally freed from water by placing it in canvas bags, which are subjected to the action of powerful hydraulic presses.

To purify the anthraquinone thus obtained the process generally used consists in treating the product with concentrated sulphuric acid at a temperature of 100° C. The anthraquinone, when treated thus, dissolves, but is not acted upon chemically. The impurities, however, combine with the sulphuric acid to form sulphonic acids which are removed by water, and nearly pure anthracene remains.

In carrying out this step of the process the crude anthraquinone and sulphuric acid are placed in circular lead-lined iron pots in the proportions of one part to three. The mass is steam-heated and agitated constantly for about twenty-four hours, at the end of which a blackish product is run into shallow tanks and subjected to a gentle current of damp air or steam until the acid is diluted. Anthraquinone separates out as a light brown crystalline powder, which is washed by

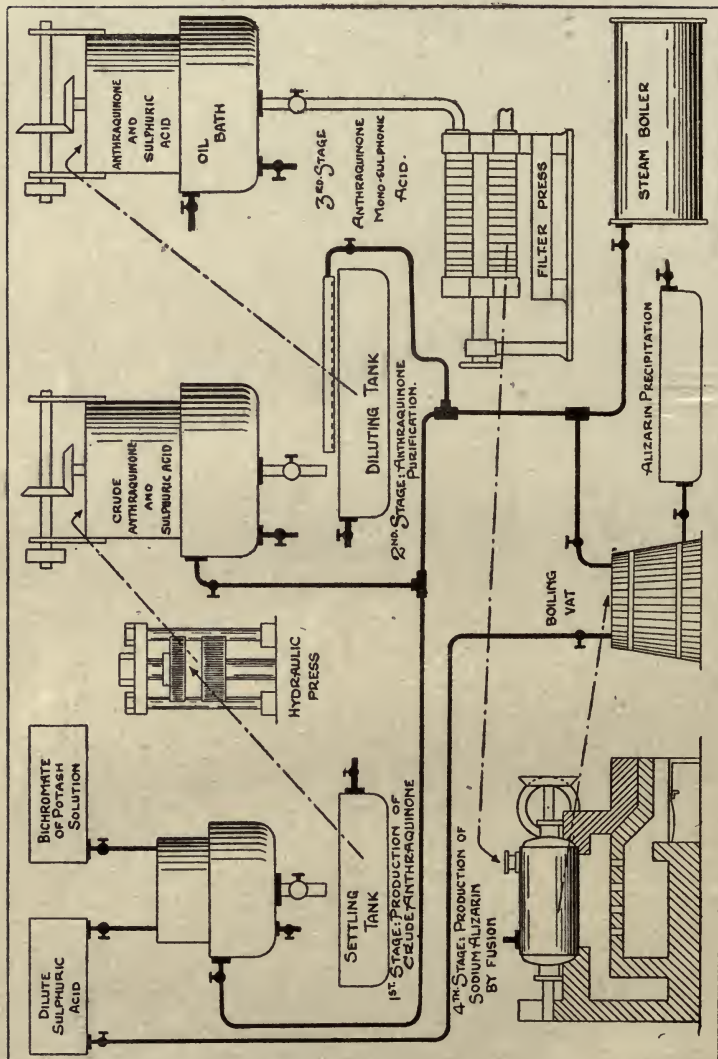
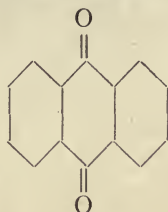

FIG. 12.—Diagram of Plant for Alizarin Manufacture.

decantation, pressed and dried, the resulting product being 95 per cent. pure anthraquinone.

The chemical action which has taken place is shown in the following structural formula of anthraquinone—



From this it will be seen that two atoms of oxygen have replaced the two hydrogen atoms at the para-positions on the middle ring. The empirical formula for this substance is $C_{14}H_8O_2$.

Several processes are used for obtaining alizarin from anthraquinone, the following being one in general use. Anthraquinone and fuming sulphuric acid, in the proportions of 1 part of sulphuric acid to $1\frac{1}{4}$ parts of anthraquinone, are placed in large iron pots capable of containing 30 to 40 gallons and heated by means of an oil bath to a temperature of 170° to 190° C., which is maintained for a period of 8 to 10 hours, during which time it is constantly stirred.

The product of this operation is anthraquinone-monosulphonic acid, having the formula—

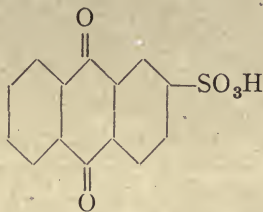

a sulphonic group (SO_3H), having been added to the

structural formula of anthraquinone. This acid is obtained diluted with water, and is subjected to the action of a filter press, and neutralised with caustic soda, and again passed to the filter press.

The crystalline sodium anthraquinone sulphonate, or "soda salt," as it is called, is collected in the filter presses in the form of brilliant pearly scales.

The final stage in the production of alizarin is carried out by fusing the soda salt in large wrought-iron cylinders fitted with mechanical stirrers, and heated by a furnace. Usually about 700 lbs. of caustic soda are dissolved in water, 1,300 lbs. of the concentrated solution of soda salt, and 13 to 15 per cent. of potassium chlorate constitute the charge for one cylinder. If the potassium chlorate is not used, loss occurs owing to the reducing action of nascent hydrogen formed during the fusion which converts the soda salt partially into anthraquinone and hydroanthraquinone. The reaction takes twenty-four hours or longer, a temperature of 180° C. being maintained throughout, whilst small quantities are extracted occasionally for laboratory examination. The resulting product is obtained in the form of an intense purple fluid, which contains the colouring matter in the form of a sodium salt of alizarin and includes also some sodium sulphite and excess caustic soda. To separate the dye, the melt is run into wooden tanks, diluted with water, and boiled with dilute sulphuric acid, as a result of which the solution turns orange, owing to the precipitation of artificial alizarin. The solution passes to settling tanks, from which the supernatant liquor is run off and washed, the colouring matter being made up into commercial form as a 10 per cent. or 20 per cent. yellow paste, in wooden tubs fitted with stirrers.

Alizarin paste is sufficiently finely divided to be appreciably soluble in hot water, but when dry it loses this property. For shipment, alizarin is usually prepared in the form of a powder, dissolved in caustic soda, and reprecipitated by hydrochloric acid at its destination.

Alizarin in its pure form is a red crystalline substance having the formula $C_{14}H_6O_2(OH)_2$ and the structural formula—

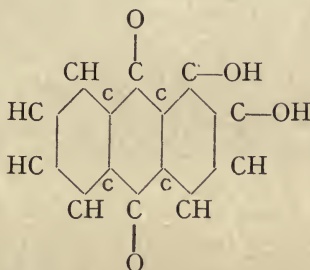

The sulphonic-group, during the last reaction above described, is replaced by a hydroxyl-group (OH), and at the same time another hydroxyl-group enters into combination at the α -position, so that the two are in ortho-position the one to the other. These hydroxyl-groups give to the compound its chemical name of 1 : 2-dihydroxyanthraquinone.

Alizarin, or turkey-red, as it is called commercially, is scarcely soluble in water, but dissolves in alkalis to a purple solution from which insoluble lakes are precipitated by using metallic hydroxides as mordants, and has been very successfully used for dyeing bright yellowish-red shades on cotton, from which, owing to the insoluble nature of the dye, the colour cannot be easily washed out.

Alizarin itself is not a dye ; hence the use of the mordants above referred to, experiment having shown that when it is combined with certain other substances new insoluble highly-coloured lakes are the result. The fabrics to be dyed are therefore mordanted or saturated with the substance known to produce the required colour, and then dipped in the purple solution of alizarin in an alkali, so that the colour is precipitated *within* the fibres, very brilliant and fast dyes being obtained in this manner owing to the insoluble nature of the new product.

Alizarin colours are largely precipitated by using metallic hydroxides, particularly the hydroxides of metals of the aluminium group. The latter being very weak bases, the compounds can be hydrolysed easily into free acid and free base ; for example, when a fabric soaked in aluminium acetate is steamed, the salt is dissociated, and when the fabric is passed subsequently through hot water in which alizarin is suspended, it is dyed a fast purple-red. To produce a brilliant scarlet or turkey-red on a cotton fabric, the latter is first mordanted with the aluminium salt of Ricinoleic acid. From this it will be seen that by the use of various aluminium salts many shades of red can be produced, whilst other shades of the same colour can be produced by using stannic or tin salts. By using ferric salts as mordants in the manner described, fabrics are dyed dark violet, and by using chromic salts, purple-brown.

So far the properties of alizarin only as a dye have been discussed, but it is now necessary to consider some examples of the large number of derivatives of anthraquinone as well as of alizarin, which are now in use as dyes. As already stated, alizarin is chemically known

as dihydroxyanthraquinone, a substance which is represented by attaching two hydroxyl (OH) groups to the structural formula of anthraquinone. There are, however, a large number of substances in use as dyes which contain more than two hydroxyl groups, and according to the number of such groups which they contain are known as tri-, tetra-, penta-, hexa-, etc., anthraquinones. It should be noted, however, that only those substances which contain at least two hydroxyl groups in ortho-position to one another (as in alizarin) possess the property of forming lakes with mordants.

A number of methods are in general use for forming derivative compounds of anthraquinone and alizarin as well as other coal-tar products, one being sulphonation with sulphuric acid, by which one or more sulphonic radicals (SO_3H) are added, the resulting products being known as sulphonic acids with the prefix mono-, di-, tri-, etc., according to the number of sulphonic groups which they contain.

Another method of producing dye-stuffs is that of nitration, which is generally carried out in fuming sulphuric acid at a low temperature, and results in the addition of a nitro-group (NO_2) to the compound. The sulphonic acids as well as the original compounds can be nitrated, and the nitro-groups can further be replaced by amino-groups.

Fusion with caustic alkalis is productive of another group of compounds, examples of which will be given later.

Alizarin Brown is a substance produced by nitrating alizarin, the process being carried out by dissolving alizarin in fuming sulphuric acid, cooling to -5° to -10° , and treating with nitric acid dissolved in

sulphuric acid. The resulting product is expressed by the formula—

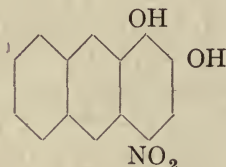

and the substance is known chemically as α -nitroalizarin 1 : 2 : 4.

By including boric acid in the sulphuric acid, the character of the reaction is changed slightly, and although only one nitro-group enters the molecule as before, it attaches itself in the third position on the structural formula, and the resulting dye is known as **Alizarin Orange**, or β -nitroalizarin.

By reducing α -nitroalizarin in an alkaline solution with sodium amalgam, the nitro-group is changed to an amino-group, and the product is known as α -aminoalizarin, or commercially as **Alizarin Garnet**.

Sulphonation of alizarin results in the production of alizarin mono-sulphonic acid, in which one sulphonic group is attached at the third position on the alizarin formula. The sodium salt of this substance is known commercially as **Alizarin Red S**.—

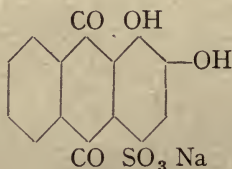

and dyes wool with alumina or chrome mordants.

We have now to consider a few examples of dyes

consisting of anthraquinone derivatives, the molecules of which contain more than two hydroxyl groups. The first of these are the trihydroxyanthraquinones, the structural formula of each containing two hydroxyl-groups in the 1 : 2 positions, whilst throughout the series the third hydroxyl occupies each position in turn from the third to the eighth. It should be remembered that, in all these compounds, the number of parts or atoms constituting the substance remains the same as in the basic substance anthracene, and that each of the radical groups acts only as a single atom for combination purposes, displacing a single hydrogen atom wherever it attaches itself. The following are important members of the trihydroxyanthraquinone series :

Anthragallol, or 1 : 2 : 3-trihydroxyanthraquinone, is obtained by condensing benzoic acid ($C_6H_5 \cdot COOH$) and gallic acid ($C_6H_2(OH)_3 \cdot COOH$) in the sulphuric acid solution, and dyes brown with chrome mordants.

Purpurin, or 1 : 2 : 4-trihydroxyanthraquinone, occurs with alizarin in madder, but is now obtained by oxidising alizarin with manganese dioxide and sulphuric acid. It gives scarlet shades with alumina mordants.

Flavopurpurin, or 1 : 2 : 6-trihydroxyanthraquinone, is prepared by alkaline fusion of anthraquinone disulphonic acid in a closed vessel with potassium chlorate. This substance dyes yellowish-red shades with alumina, and violet-red with iron mordants.

Anthrapurpurin or **Isopurpurin**, 1 : 2 : 7-trihydroxyanthraquinone, is obtained by alkaline fusion of anthraquinone—2 : 7—disulphonic acid, and is used for dyeing red shades on alumina mordanted cotton.

Commercial **Alizarin** frequently contains either or both **Flavopurpurin** and **Anthrapurpurin**, on account

of the fact that the anthraquinone sulphonic acid used in the manufacture of alizarin often contains a certain amount of the disulphonic acids.

An important dye of the tetrahydroxyanthraquinone group is known commercially as **Alizarin Bordeaux**. These poly-hydroxyanthraquinones owe their existence as dyes to the discovery made by Bohn in 1890, that by the action of fuming sulphuric acid on anthraquinone, and anthraquinoline derivatives, new hydroxyl groups could be introduced, the reaction being better in the presence of boric acid.

The oxidation of alizarin to **Alizarin Bordeaux** is effected by fuming sulphuric acid containing 80 per cent. sulphurous acid SO_3 , the resulting product having the formula—

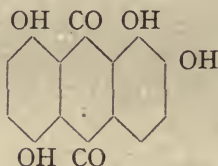

1 : 2 : 5 : 8 Tetrahydroxyanthraquinone

Alizarin Bordeaux forms claret lakes with aluminium and violet-blue with chrome salts.

Oxidation of **Alizarin Bordeaux** by any suitable oxidising agents, but principally with manganese dioxide and sulphuric acid, forms a blue chromium lake much used in wool dyeing—**Alizarin Cyanine R.**, or 1 : 2 : 4 : 5 : 8-pentahydroxyanthraquinone, having the structural formula—

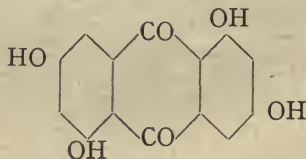

The poly-hydroxyanthraquinones above described can themselves be nitrated, sulphonated, and otherwise treated, to produce a further set of compounds; for example, nitration of **Flavopurpurin** gives **Nitroflavopurpurin** 1 : 2 : 6 : 3, having the formula—

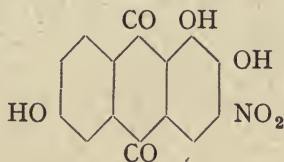

and known as **Alizarin Orange G**.

A considerable number of other dyes are used which are derivatives of the hydroxyanthraquinones, but enough have already been described to make clear the nature of these compounds, and the manner in which they can be formed one from another by suitable treatment to substitute various radical groups for the original hydrogen atoms and for one another.

The substances which have so far been discussed in this chapter are all mordant dyes, but a large class of acid wool dyes are in use, which, although anthraquinone derivatives, dye without mordants. It has already been pointed out that a number of hydroxyanthraquinones exist which in themselves are not dyes, neither do they dye with mordants, and further, that these substances do not possess two hydroxyl groups in ortho-position to one another. We shall now see that by nitrating, sulphonating, and otherwise treating these substances they produce the acid wool dyes above referred to.

An example of these acid wool dyes is **Anthrachryson**, or 1 : 3 : 5 : 7-tetrahydroxyanthraquinone, which, as will be observed from the following formula,

does not possess two hydroxyl groups in ortho-position to one another.

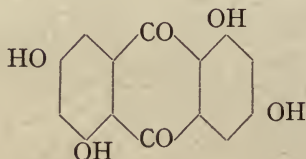

This substance is prepared by heating 3:5-dihydroxybenzoic acid with ten times its volume of sulphuric acid for from three to five hours. Sulphonation, and nitration of this substance, produce **Dinitroanthrachryson disulphonic acid**, which dyes fast brown shades on wool, and has the formula—

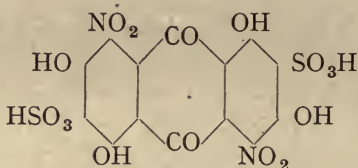

Reduction of this acid, by which the nitro (NO₂) groups are replaced by amino-groups (NH₂) gives **Diaminoanthrachryson disulphonic acid**, which dyes wool violet from an acid bath, or blue on chromium mordant.

If the reduction is carried out in an alkaline solution with sodium sulphide, **Acid Alizarin Green** results, which dyes chromed wool a fast pure green.

By boiling diaminoanthrachryson disulphonic acid with an alkali, **Acid Alizarin Blue** is obtained. By this dye a red shade is produced on wool from an acid bath, which on chroming develops a beautiful blue, which is fast to light, milling, acids, and alkalis.

Quinizarin is 1 : 4-dihydroxyanthraquinone, and has no dyeing properties, but, in common with other anthraquinone derivatives, possesses an important property by which negative substituents such as the nitro-groups (NO_2), hydroxyl-groups (OH), and also amino-groups (NH_2) can be readily replaced by substituted amino-groups NHR , in which the letter R indicates an alkyl or aryl radical, which has replaced one of the hydrogen atoms in the amino-group. This reaction is productive of a number of wool dyes; for example, when quinizarin is treated with an excess of aniline and sulphonated, the sodium salt of the sulphonic acid is a dye-stuff known as **Quinizarin Green**, having the formula—

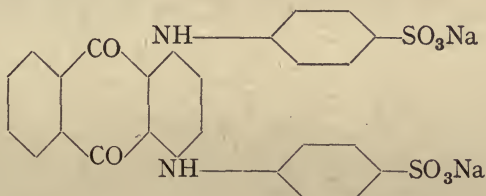

In this substance it will be seen that the two hydroxyl groups have been replaced at the 1 : 4 positions by two substituted amino-groups indicated by the letters NH , and the rings linked thereto. For the sulphonic acid these rings would, of course, have two sulphonic (SO_3H) groups attached, but the hydrogen atoms having been replaced by sodium, the letters Na appear, indicating the sodium salt.

This dye produces green shades on wool from an acid bath, fast to light and milling.

When the hydroxyanthraquinones which contain* nitro- or amino-groups are treated with glycerol and

sulphuric acid, another group of anthracene derivatives is formed—the anthraquinolines. Treatment of β -nitro or β -aminoalizarin in this manner produces **Alizarin Blue**, in which a nitrogen-containing ring is added to the alizarin formula, taking the place of two hydrogen atoms, this ring being characteristic of the anthraquinoline dye-stuffs. **Alizarin Blue** has the formula—

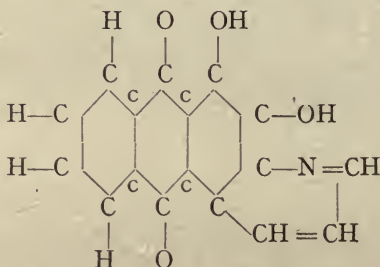

Treatment of α -aminoalizarin with glycerol and sulphuric acid produces **Alizarin Green**, which differs from the blue, above described, only in the arrangement of the nitrogen-containing ring, as shown by the following formula, in which the atoms and radicals of the alizarin nucleus are omitted.

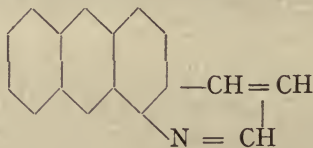

Both **Alizarin Blue** and **Green** may be treated with sodium bisulphite to form their bisulphite compounds, which give modified shades and are known respectively as **Alizarin Blue S.**, and **Alizarin Green S.**

Another class of dyes in regard to which important developments have taken place in recent years is known as the Anthracene Vat Dyes. By the term "vat dye" is understood a pigment insoluble in water, which on reduction with an alkaline reducing agent yields colourless or slightly coloured compounds which are soluble in alkali. These compounds are absorbed by fabrics steeped in the alkaline solution, and are reconverted into pigments when the materials are exposed to the oxidising action of the air, indigo being a typical example of this important class of dyes, which produces shades very fast to light and washing.

In the year 1901 Bohn made the discovery that certain derivatives of anthraquinone could be applied as vat dyes, the first of these to be produced being **Indanthrene**, which is manufactured by fusing β -aminoanthraquinone with caustic potash at a temperature of 200°-300° C. This action results in the production of a soluble potassium salt of a blue hydro-derivative which, when dissolved in water with free access of air, is converted into the insoluble blue colouring matter with which fabrics are dyed as above described.

Another important vat dye is **Flavanthrene**, which is generally prepared by treating β -aminoanthraquinone with antimony pentachloride in boiling nitrobenzene. **Flavanthrene** dyes blue shades on cotton, which on exposure to air become a bright yellow; hence the alternative name of the dye, **Indanthrene Yellow**.

In recent years a large number of experiments have been carried out by treating anthraquinone, and its various reduction products and derivatives, with the object of introducing fresh radicals into the compounds, and testing the results as dye-stuffs. That this experimental work has proved to a large degree successful

is evident from the great number of patents granted in recent years in connection with new anthraquinone dye-stuffs; and as soon as a new group of dye-stuffs is evolved, the various methods of sulphonation, nitration, reduction, etc., are applied to produce further compounds of an ever-increasing complexity of composition.

It is interesting to note that during the time that this book has been in preparation, an announcement has been made that British chemists have succeeded in preparing **Indanthrene** satisfactorily, and it has been placed on the market by British Dyes, Limited, under the name of **Chloranthrene Blue**.

CHAPTER V

ARTIFICIAL INDIGO AND ALLIED DYES

THE artificial indigo industry, which has now almost supplanted that of the natural product, owes its origin to the persistent researches of Van Baeyer, who in the year 1880 first succeeded in producing indigo by artificial means. It was nearly seventeen years later, however, before it was placed on the market, the intervening period being occupied with numerous researches with the object of discovering more economic methods of effecting the various stages of the process so as to enable the artificial colouring matter to be produced at a price sufficiently low to compete with the natural product.

Since its introduction its success in practically driving the natural product off the markets of the world has been due largely to the fact that the artificial product is more certain in action and produces a more effective colour. A number of methods have been found of producing artificial indigo, some utilising aniline derivatives as a base, and others naphthalene derivatives. The latter are now more generally used, owing to the large quantities of naphthalene contained in coal-tar compared with other constituents. Naphthalene having the formula $C_{10}H_8$, or—

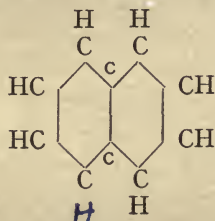

is first oxidised with concentrated sulphuric acid with mercury or mercury sulphate to form phthalic acid. The mercury, or mercury compound, takes no visible part in the reaction, which, however, will not take place without it. This property of promoting chemical action without apparently taking part in it is called catalytic action, and up to the present is very imperfectly understood.

The oxidation step is generally carried out in practice by dissolving naphthalene in fuming sulphuric acid in the proportions of one part of the former to fourteen of the acid. This is kept in a large elevated reservoir, from which it is transferred to a cast-iron distillation pan through a measuring tank. In order to obtain a clearer understanding of these operations reference is directed to the diagram of plant shown in Fig. 13. The distillation pan is first coated with a mercury preparation by charging it with 120 parts of sulphuric acid and 4 parts of mercury, and heated for about one and a half hours, at the end of which time the excess of sulphuric acid and sulphurous acid distil over. The temperature is then lowered to about 300° C., and the contents of the measuring tank run into the distillation pan. Each quantity distils over in fifteen minutes, or a little more, and the process is repeated until the accumulation of carbon in the pan becomes large enough to stop work.

During the operations just described a considerable change takes place in the arrangement of the atoms of carbon and hydrogen which form the molecules of naphthalene. A very large portion of the distillate consists of sulphur dioxide and sulphurous acid, calculations having shown that for every pound of naphthalene oxidised, about four and a half pounds of sulphur dioxide are evolved. The success of the

DIAGRAM OF PLANT FOR THE MANUFACTURE OF SYNTHETIC INDIGO.

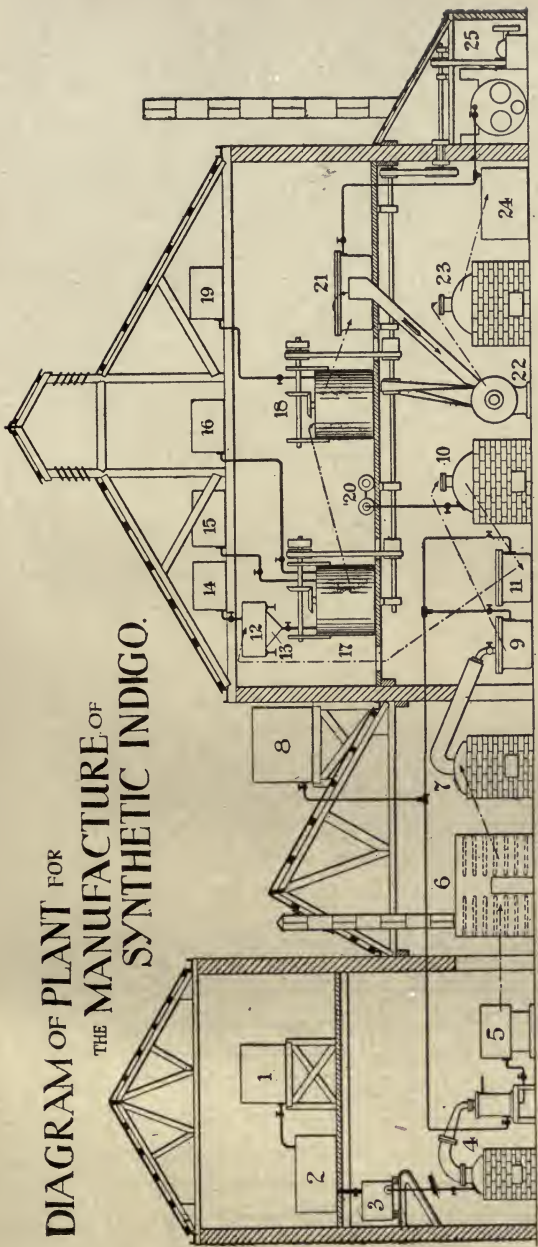
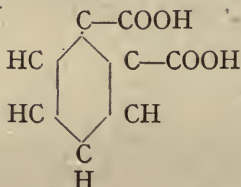

FIG. 13.

- | | | | |
|---|---------------------------------------|---|---------------------------|
| 1. Sulphuric Acid Tank. | 8. Water Tank. | 15. Hydrochloric Acid Tank. | 20. Ammonia Cylinders. |
| 2. Mixing Tank. | 9. Cooling Pan. | 16. Sulphurous Acid Tank. | 21. Drying Pan. |
| 3. Measuring Tank. | 10. Gas Furnace : Phthalimide formed. | 17. Formation of Anthranilic Acid. | 22. Ball Mill. |
| 4. Still : Formation of Phthalic Anhydride. | 11. Cooling Pan. | 18. Formation of Phenylglycine-o-Carboxylic Acid. | 23. Gas Furnace. |
| 5. Hydro-extractor. | 12. Mixing Tank. | 19. Chloracetic Acid Tank. | 24. Indigo Precipitation. |
| 6. Drying Stove. | 13. Filter. | | 25. Power House. |
| 7. Still. | 14. Caustic Soda Solution Tank | | |

process largely depends on the recovery of the sulphuric acid used, the sulphur dioxide and sulphurous acid being passed from the condenser to absorbers, converted into sulphuric acid by the contact process, and used many times over.

During the distillation phthalic acid forms in the pan owing to the rearrangement of hydrogen and carbon atoms already referred to. Some of these combine with oxygen atoms from the sulphuric acid to form carboxyl groups (COOH), which are seen attached in ortho-position to a benzene ring in the phthalic acid formula—



The loss of oxygen from the sulphuric acid (H_2SO_4) is clearly shown by the evolution of sulphur dioxide (SO_2) and sulphurous acid (H_2SO_3).

During the distillation, however, the phthalic acid is changed to phthalic anhydride, which is phthalic acid without water, as shown by its formula—

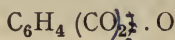

The distillate is passed to a hydro-extractor in which the phthalic anhydride is separated from the other substances, and subsequently dried in stoves. It is then redistilled in iron cylinders, and the molten distillate run into shallow water-cooled pans, and solidified.

The next operation consists in the production of phthalimide. This is accomplished by melting 650

parts of phthalic anhydride in a gas-heated cast-iron boiler for four hours, the temperature rising during this time to 140° C. In seven to eight hours it is raised to 170° C., at the end of which time it is raised to 240° C. At this point about 75 parts of gaseous ammonia are admitted from pressure cylinders, the complete operation occupying eighteen hours. The molten phthalimide which is formed is run into pans, cooled, and then ground up.

Phthalimide is, in its pure state, a crystalline substance having the formula $C_6H_4(CO)_2.NH$, an imino-group having replaced the oxygen atom in the anhydride molecule.

Phthalimide is next dissolved in the proportion of about 500 parts in a cold solution containing 144 parts of chlorine, 640 parts of caustic soda, and 440 parts of water. The solution is filtered, blown into an agitated vat, and saturated with sulphurous acid. On the addition of 600 parts of hydrochloric acid, anthranilic acid separates out. This substance is known chemically as *o*-amidobenzoic acid, having the formula $C_6H_4(NH_2).COOH$.

The next step in the process takes place in a lead-lined tank fitted with a wooden agitator. Into this receptacle are introduced about 1,300 parts of anthranilic acid dissolved in 800 parts of caustic soda. This is cooled by the addition of 800 parts of ice; 670 parts of chloracetic acid dissolved in 50 parts of water are added, and the contents of the tank are stirred for five hours, being kept alkaline throughout by the addition of caustic soda to the amount of about 900 parts. The result is phenylglycine-*o*-carboxylic acid, which appears first as a dark coloured viscous mass, which is dried in pans heated to 50° C. until hard and crystalline, and then finely ground. Water is added

94 ARTIFICIAL INDIGO AND ALLIED DYES

and the whole treated in a hydro-extractor. The chemical nature of the change which has taken place is shown by substituting two groups of atoms for one of the hydrogen atoms in the amino-group in the anthranilic acid formula, thus—

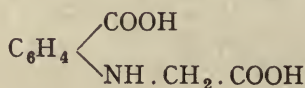

Phenylglycine-o-carboxylic acid, when fused with an alkali, is converted into indoxyl, an unstable, oily liquid soluble in water, acids, and alkalies, and having the formula—

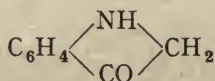

To effect this change the acid and caustic soda in the proportions of about 6 parts of the former to 10 of the latter are ground in a ball mill, air being excluded, and the ground material collected in sheet-iron receptacles, which are transferred to a gas-heated furnace fitted with stirrers and heated to a temperature of 250° C. for about three hours. The receptacles are then removed, and their contents washed out into a large iron tank, steam-heated to 115° C., into which air is blown at the same time. Indigo then begins to separate out, and after cooling and treating in a filter press the dye-stuff is ground with water to a 20 per cent. paste into which a little gum is sometimes worked.

When indoxyl is oxidised by blowing in air as above described, the oxygen combines with the hydrogen atoms in the CH₂ group to form water, and in place of

ARTIFICIAL INDIGO AND ALLIED DYES 95

these atoms another molecule becomes linked through its carbon atom, as shown in the formula—

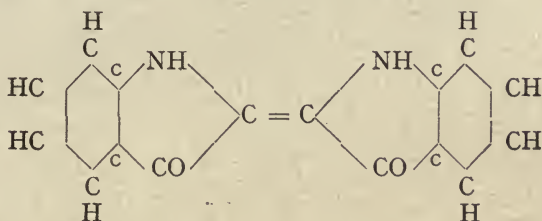

This is the formula of indigotin, or indigo blue, and may also be expressed $C_{16}H_{10}N_2O_2$. When the structural formula is carefully examined it will be found to comprise two benzene nuclei linked together by two NH groups, two CO groups, and two carbon atoms, the latter, it will be observed, being linked to each other by a double bond. This may be explained by the fact that carbon is a quadrivalent substance, that is, one atom of it will combine with four atoms of other monovalent elements, or radical groups. In the above formula each carbon atom is combined with an NH and CO group, which are substituted for two atoms of hydrogen in the rings. The carbon atoms have therefore two links each left, with which they are combined with one another. For the sake of convenience the indigo formula is frequently written—

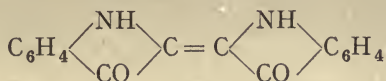

An alternative process for the manufacture of artificial indigo, and one that is in fairly general use, utilises benzene as a base. The benzene is first nitrated and reduced to aniline in the manner described

96 ARTIFICIAL INDIGO AND ALLIED DYES

in Chapter III., the aniline being subsequently heated with chloracetic acid to form a substance known as phenylglycine. The reaction may be represented by the following chemical equation—

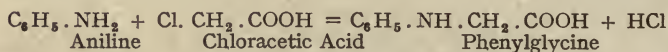

From this it will be evident that the new compound includes all the components of the aniline and chloracetic acid, with the exception of some hydrogen and chlorine (represented by the letters HCl) given off during the reaction.

The next step in this process consists in melting the phenylglycine with caustic soda to form indoxyl, but as it has been found that the high temperature necessary for fusion causes a large amount of the phenylglycine to be destroyed by the alkali, thereby rendering a poor yield of indoxyl, chemists have endeavoured to find new and more satisfactory methods of performing this step at a lower temperature. As a result of their researches, caustic soda has now given place to sodamide, a substance made by heating metallic sodium in a current of dry ammonia and having the formula $\text{Na} \cdot \text{NH}_2$.

When phenylglycine and sodamide are heated together, the melt includes indoxyl and caustic soda, whilst ammonia is given off and collected to be used over again in the formation of sodamide. The melt is then dissolved in water, and air blown through to oxidise the indoxyl to indigo.

Indigo is completely insoluble in water, and in its pure state consists of dark-blue crystals. The artificial product is generally sold in the form of a paste containing 20 per cent. pure indigo.

The processes described above for the production of

artificial indigo may be varied in certain stages, four processes similar as regards many of their details being in general use. Fig. 14 shows diagrammatically four processes used by well-known manufacturers, arranged for comparison. From the length and complexity of the processes described, some idea will be gained of the patience and perseverance of the chemists who made the artificial production of indigo possible on a commercial scale.

As stated above, indigo is insoluble in water, and, therefore, being incapable of use directly as a dye, must be converted into soluble derivatives, which can either be precipitated within the fibres or actually combined therewith.

Indigo is a typical vat dye, and, before dyeing, is reduced to **Indigo White**, in which the two oxygen atoms in the indigo molecule are replaced by two hydroxyl groups, the reduction being carried out with sodium hydrosulphite and alkali. Fibres such as cotton, wool, or silk are immersed in the alkaline solution, and subsequently oxidised by exposure to air to precipitate indigo within the fibres.

When indigo blue is dissolved in fuming sulphuric acid, **Indigo sulphonic acid** is formed, which dyes wool directly by combining with the fibres and gives the shade known as **Saxony Blue**. A disulphonic acid can also be formed, known as **Indigo Carmine**, an acid wool dye.

A number of indigo derivatives are also dye-stuffs, and among these the Halogenised Indigo Dyes form an important group. In obtaining these derivatives one or more of the hydrogen atoms of the benzene nuclei of indigo is or are replaced by the halogens, bromine or chlorine. This is generally effected by one or other of two methods, the first consisting in the treatment of

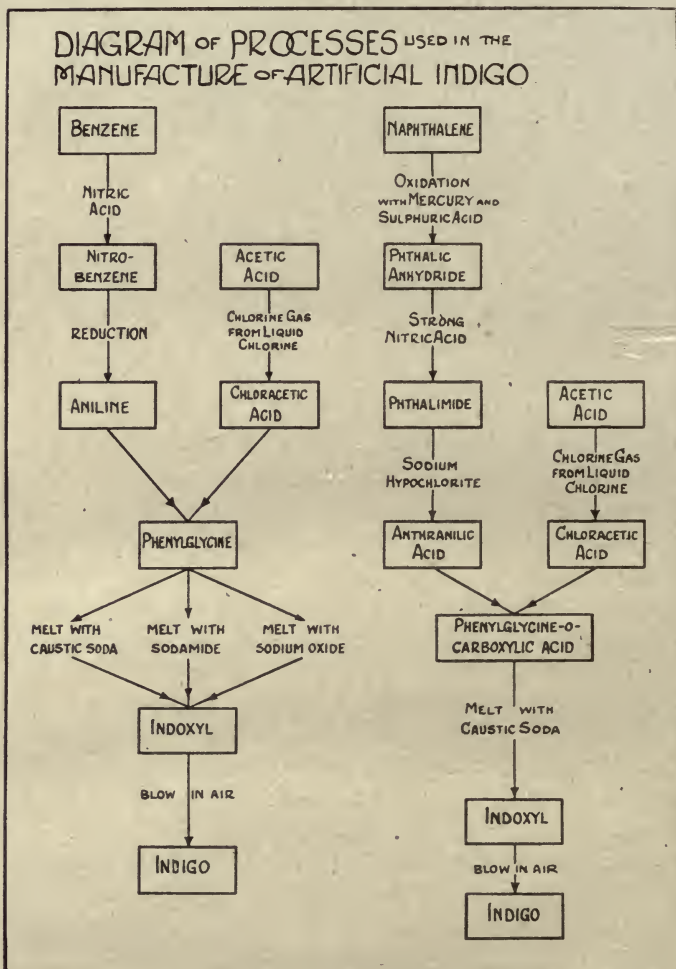

FIG. 14.

indigo or a derivative suspended or dissolved in various substances, with a halogen or halogenising agents. The second method consists in the introduction of chlorine or bromine at an earlier stage in the manufacture of indigo; for example, a brom- or chlor-phenylglycine-*o*-carboxylic acid may be obtained and oxidised, and otherwise suitably treated to form a halogenised dye.

When indigo, suspended in a medium such as nitrobenzene, is treated with bromine at a raised temperature, substances known as **Tri-** and **Tetra-bromindigo** are produced, in the one case three atoms of bromine replacing three of hydrogen, and in the other case four atoms. In a similar manner the introduction of chlorine results in the production of **Tri-** and **Tetrachlorindigos**. All these substances dye reddish-blue shades.

By treating indigo suspended in concentrated sulphuric acid with bromine in the absence of heat, **Penta-** and **Hexa-bromindigos** are produced, which dye greenish-blue shades.

Indirubin is a substance having the same empirical formula as indigo, $C_{16}H_{10}N_2O_2$, but the atoms are arranged differently in the structural formula. This substance, which is sometimes known as **Indigo Red**, is of little use as a dye, but, as will be seen later, forms the basis of a number of useful dye-stuffs. **Indirubin** is prepared by condensing together indoxyl and isatin. The latter is an orange-coloured crystalline substance, which is formed by boiling indigo with dilute nitric, or chromic acid, and cooling the product.

Various methods are known for brominating **Indirubin**, and mono- to hexa-brom-derivatives are obtained which dye various reddish-blue shades.

One of the most important of these is **Tetra-bromindirubin**, which is better known under its trade name of **Ciba Heliotrope**.

100 ARTIFICIAL INDIGO AND ALLIED DYES

Thioindigo is an important substance, very similar to indigo, but containing sulphur instead of the imino-(NH) groups. It is not made directly from indigo, however, the processes, about six in number, which are in general use, starting from anthranilic acid or thiophenol-*o*-carboxylic acid, the following being an example. Anthranilic acid having the formula—

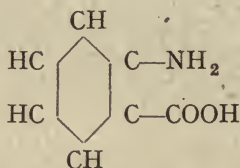

is diazotised and treated with thioglycollic acid (SH . CH₂ . COOH), by which means the amino-group (NH₂) is displaced by a group containing sulphur and a second carboxyl group, the resulting product being known as phenylthioglycollic-*o*-carboxylic acid, having the formula—

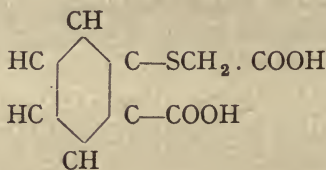

When this substance is heated with caustic soda, or acetic anhydride, a rearrangement of the molecules takes place, and one atom of oxygen and two atoms of hydrogen leave the compound as water, whilst

ARTIFICIAL INDIGO AND ALLIED DYES 101

thioindoxyl carboxylic acid is formed, having the formula—

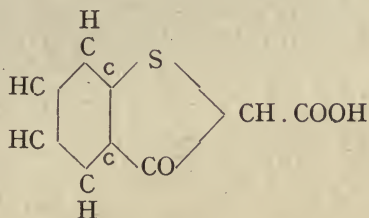

Heat is again applied, and carbon dioxide is given off, leaving thioindoxyl—

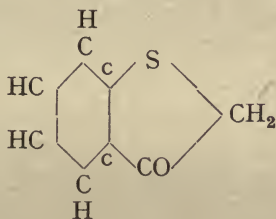

condensation and oxidation of which gives **Thioindigo**, or **Thioindigo Red**.

An alternative method consists in treating anthranilic acid with sulphur containing bodies to form thio-salicylic acid. This is usually carried out by mixing anthranilic acid with water and hydrochloric acid, and diazotising by the addition of a concentrated aqueous solution of sodium nitrite. Ice is added to keep the temperature at a low point, and the diazo solution is constantly stirred and slowly run into a solution containing sulphur, and sodium sulphide in water, to which aqueous caustic soda has been added. The mass is cooled with ice to keep the temperature below 5° C.

After a short time nitrogen is evolved in large quantities, and the temperature rises to 15° — 25° C., due to the formation of dithiosalicylic acid. After about two hours hydrochloric acid is added, and the precipitated dithiosalicylic acid is filtered and washed with water.

The acid is brought into solution as the sodium salt by boiling with anhydrous sodium carbonate in water. The solution of the sodium salt is then mixed with iron powder and boiled for some hours, after which the iron is precipitated by the addition of caustic soda solution, and the mixture boiled and filtered. By the addition of acid, thiosalicylic acid is caused to separate as a colourless or pale yellow crystalline substance which is filtered and washed. By this process the amino-group of anthranilic acid has been eliminated and a sulphur-containing group substituted therefor, thiosalicylic acid having the formula—

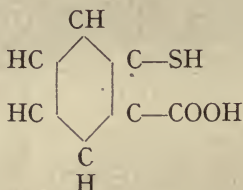

When this is treated with monochloroacetic acid ($\text{CH}_2\text{Cl}\cdot\text{COOH}$), in alkaline solution under the influence of heat, phenylthioglycine-*o*-carboxylic acid is formed, having the formula—

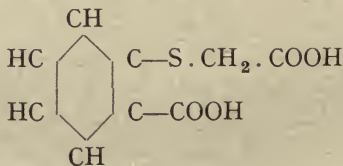

When this is melted with caustic soda thioindoxyl

carboxylic acid is formed from which **Thioindigo Red** is obtained as above described. This substance has the formula—

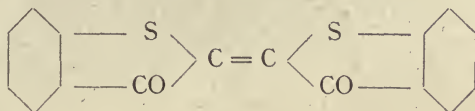

the atoms on the benzene nuclei being omitted for the sake of clearness.

A number of derivatives of **Thioindigo** have been obtained, among which the amino compounds are worthy of notice. The *m*-amino compound has the formula—

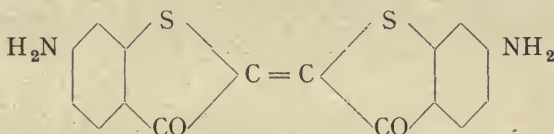

and dyes brown shades, whilst the *p*-amino compound has the formula—

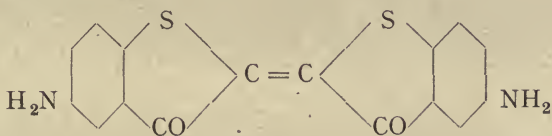

and dyes black shades. Halogen derivatives of these amino compounds have also been obtained which dye orange and black shades respectively.

Thioindigo Scarlet is not a direct **Thioindigo** derivative, but stands in the same relation to **Indirubin** as **Thioindigo** does to **indigo** itself, being known technically as an analogue of that substance. To obtain **Thioindigo Scarlet**, thioindoxyl is condensed with isatin,

the result being an unsymmetrical dye containing only one thionaphthene residue, and having the formula—

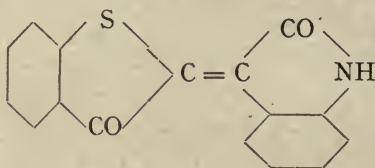

Thioindigo Red and **Scarlet** yield a further number of dye-stuffs by the substitution of halogens for hydrogen atoms, these derivatives dyeing various shades of scarlet, bluish red, and reddish-violet, and constituting a very useful series of vat dyes.

With these examples our rapid survey of the manufacture of artificial indigo and its allied dye-stuffs must be brought to a close, but it should be remembered that the industry is a comparatively new one, and an immense field remains to be explored by experimental chemists, who in the next few years will undoubtedly add many more to the number of vat dyes which, as will be seen from a later chapter, are very easily applied to fabrics compared with other dye-stuffs, over which they have a great advantage in this respect.

CHAPTER VI

THE ARYLMETHANE DYES

WE have now to consider a very extensive group of dye-stuffs, which are theoretically substitution products of methane (CH_4), also known as marsh gas. To understand fully the composition of these dye-stuffs it should be remembered that carbon is known as a quadrivalent substance, that is, an atom of carbon is capable of uniting with four atoms of a univalent substance, such as hydrogen. In the composition of methane, therefore, the combining power of the carbon atoms is utilised to its fullest extent, and in using methane as the basis of new compounds, atoms of other elements, or radicals, may be substituted for some or all of the hydrogen atoms. A large number of substances may be formed in this manner, those which include an aromatic radical or group such as the phenyl radical (C_6H_5) being known as arylmethane compounds.

The first group of dye-stuffs constituted on these lines is comprised by the derivatives of diphenylmethane. This substance, as its name implies, is a substitution product of methane in which two phenyl radicals are substituted for two of the hydrogen atoms, the formula being usually expressed—

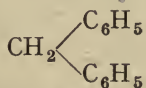

This formula, and many of the formulæ in the succeeding pages, will be better understood by

remembering the quadrivalent nature of the carbon atom referred to above, and by examining briefly a more graphic representation of the constitution of diphenylmethane, thus—

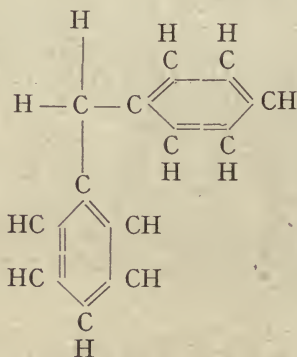

In this it will be seen that two valencies of the carbon atom in the methane molecule are united to carbon atoms in two benzene rings in place of two hydrogen atoms, whilst the two remaining valencies of the "central" carbon atom are united to the two remaining hydrogen atoms of the methane molecule. The six carbon atoms and five hydrogen atoms remaining in each of the two rings constitute what is known as the phenyl radical, one of those groups of atoms which enter into combinations in the manner of a single atom, but which have so far not been isolated.

Diphenylmethane is usually prepared by mixing and agitating benzene and formaldehyde in the presence of concentrated sulphuric acid, the reaction being expressed as follows—



Diphenylmethane crystallises in long, colourless, prismatic needles, and does not possess dyeing

properties. Among its derivatives, only **Auramine** and some of its compounds are of any importance as dyes. In the manufacture of auramine a substitution product of diphenylmethane, namely, dimethyl-tetramethyl-diaminodiphenylmethane, forms the basis of the operation, 14 parts by weight of this substance being heated with 6 parts of sulphur, 7 parts of ammonium chloride and 120 parts of sodium chloride in a current of dry ammonia for eight hours at a temperature of 175° C. The resulting product is washed with cold water, dissolved in water at a temperature of 70° C., filtered, pressed, and dried. It may be crystallised, and forms yellow scales.

Auramine dyes wool and silk direct, and gives a pure yellow fairly fast to light and soap, but commercially is chiefly used for cotton, which must, however, be mordanted with tannin and tartar-emetic. Compound shades can also be produced with other basic dyes, such, for example, as **Safranine**, fixed by the same mordant.

By substituting other radicals for those which constitute the **Auramine** molecule, a number of other important substances, such as **Methylauramine**, **Ethylauramine**, and **Phenylauramine** are produced, which are also cotton dyes giving reddish- or brownish-yellow shades with the mordants above noted.

Another arylmethane compound from which an exceedingly large and important series of dye-stuffs is produced is Triphenylmethane ($C_{19}H_{16}$) the structural formula of which is found by substituting a third phenyl radical for one of the hydrogen atoms of the methane molecule, thus—

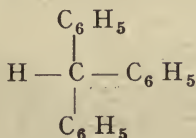

The dye-stuffs which are members of what is known as the triphenylmethane group vary in character and dyeing properties more than those of any other group, and include dyes for wool, silk, and cotton, applicable to almost any kind of dyeing, or colour-printing, the only connecting link between the members of this group being their chemical constitution, of which the above formula is a prototype.

In these dyes the hydrogen of triphenylmethane is replaced by salt-forming groups, and it is, therefore, termed a chromogen. Each phenyl radical may be replaced by any other aromatic radical, and all the hydrocarbons thus formed will yield dye-stuffs.

The triphenylmethane dye-stuffs, which are used commercially, however, are derived from comparatively few hydrocarbons, of which triphenylmethane itself is the most important. Tolyldiphenylmethane, naphthyldiphenylmethane, ditolyldiphenylmethane, and tritolylmethane are the principal parent substances of a large number of dye-stuffs extensively manufactured.

Triphenylmethane was first prepared in the year 1872 by Kekulé, the originator of the hexagon formula. At the present day it is prepared by mixing 2 parts of chloroform with 7 parts of benzene and aluminium chloride. When the evolution of hydrogen chloride has ceased the resulting liquid is washed with water and dried. Distillation of this liquid yields benzene, diphenylmethane, and triphenylmethane, the latter being purified by crystallisation, forming colourless crystals.

Triphenylmethane has three principal derivatives, which, although not dyes, and not even coloured, form in themselves the starting-points in the manufacture of

many valuable dye-stuffs. The first of these substances is triphenylcarbinol, a tertiary alcohol, having the formula $C_{19}H_{16}O$ or CPh_3OH , where Ph represents the phenyl radical. This substance is obtained by oxidising triphenylmethane with chromic acid.

By treating triphenylmethane with fuming nitric acid, the second of these substances is formed—trinitrotriphenylmethane, having the formula $C_{19}H_{13}N_3O_6$. Treatment of this substance with chromic acid gives tri-*p*-nitrotriphenylcarbinol, $C_{19}H_{13}N_3O_7$, which is crystallised from glacial acetic acid. This substance has the structural formula—

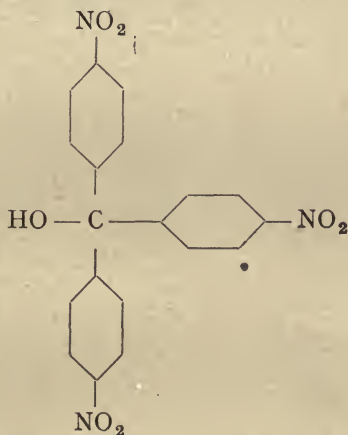

When this substance is reduced by adding zinc dust to its solution in acetic acid, triaminotriphenylcarbinol results, another name for which is **Pararosaniline**, the formula for which is given on the next page—

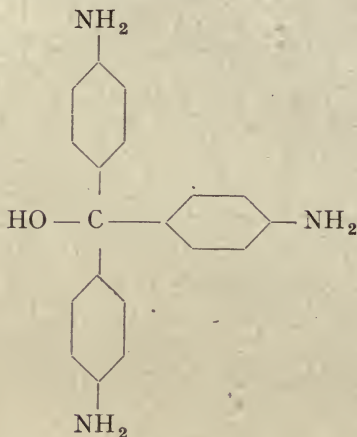

When pararosanine is acidified with dilute hydrochloric acid it yields a dye-stuff, **Pararosanine Chloride**, having the formula $C_{19}H_{18}N_3Cl$, which may be expressed structurally as follows—

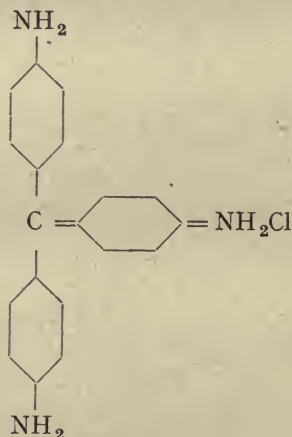

In the reaction the character of the compound has been altered, and one of the rings has become quinonoid in form. The hydroxyl group disappears, and an atom of chlorine attaches itself to the quinonoid

ring. **Pararosaniline Chloride** dyes wool and silk a fast purple-red, and cotton with mordants.

Magenta is one of the oldest synthetic dyes, having been brought out in the year 1859, and is an important member of the triphenylmethane group. It is also known as **Fuchsine** or **Rosaniline Chloride**, and is, to give it the full chemical name, the hydrochloride of triaminodiphenyltolylcarbinol, having the formula $C_{20}H_{20}N_3Cl$, or the structural formula—

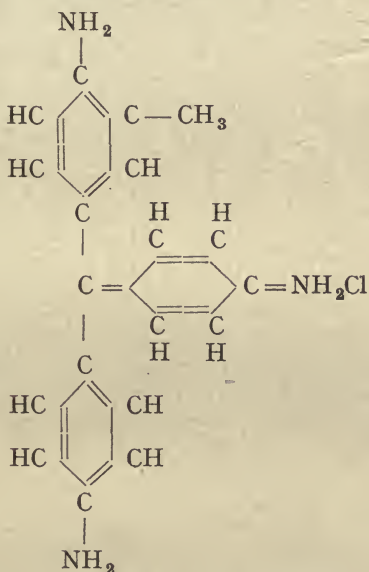

In this formula it will be observed that the whole four methane hydrogen atoms have disappeared, the four valencies of the central carbon being linked instead to three rings, one of which contains a methane-group (CH_3), whilst all contain amino-groups (NH_2). The central ring is of quinonoid structure, and therefore the carbon atoms at the top and bottom of the hexagon have two free valencies for external combination, the top in this case completing the saturation of the

central carbon, whilst the bottom is linked to an atom of chlorine as well as an amino-group.

Magenta may be manufactured by dissolving three amines, aniline, ortho-toluidine, and para-toluidine in hydrochloric acid, and heating to 190° C. with the requisite amount of nitrobenzene, iron filings being added periodically. The heating is continued for several hours, after which the aniline is distilled off with steam, and the magenta extracted with boiling water. Magenta in its pure state is a crystalline substance, nearly black in colour, but having a sort of green metallic lustre. It dissolves freely in water and alcohol to a crimson solution, which dyes silk and wool a fast purple-red. It is a basic dye, and, therefore, requires a mordant, tannin being preferably employed, before the red can be produced on cotton.

The hydrogen atoms of the amino-groups of rosaniline may be substituted by alkyl groups, the discovery of this property being due to Hofmann. A number of basic dye-stuffs formed in this manner will now be described, the first of which is **Malachite Green** or **Benzaldehyde Green** ($C_{23}H_{25}N_2Cl$), or—

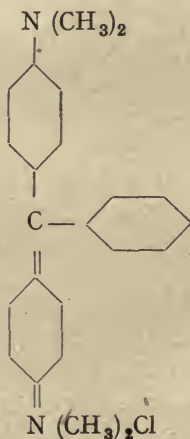

the carbon atoms, and the non-substituted hydrogen atoms of the rings being omitted for the sake of clearness, this applying also to other formulæ which follow.

Malachite Green is technically tetramethyldiaminodiphenylmethane chloride, and is prepared by heating together benzaldehyde, dimethylaniline, and anhydrous zinc chloride for several hours in a water bath. Some of the dimethylaniline remains unchanged, and is removed by distillation with steam, the resulting compound being dissolved in dilute hydrochloric acid, and oxidised to the carbinol by the addition of freshly precipitated lead peroxide. The dissolved lead is precipitated with sodium sulphate, and the carbinol converted into the double zinc chloride of the dye by precipitation with zinc chloride. This dye produces a dark green on wool, silk, and tannin mordanted cotton. In appearance it is a crystalline substance nearly black in colour, but is usually sold as the double zinc chloride already described.

Hofmann's Violet ($C_{26}H_{32}N_3Cl$) is a typical rosaniline-substitution product, being, in fact, the hydrochloride of triethylrosaniline, having the structural formula—

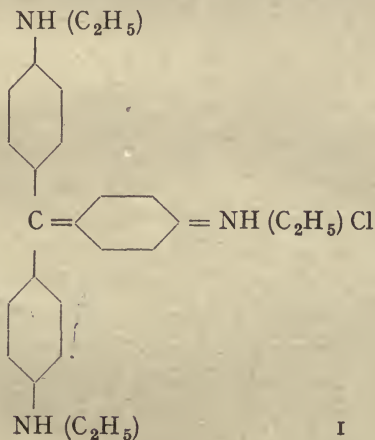

In manufacturing this dye-stuff a magenta base is first prepared by decomposing a weak fuchsine solution with ammonia or milk of lime. The magenta base is then heated together with ethyl iodide, chloride, or bromide, and an alcoholic soda solution in a sufficient quantity to neutralise the acid formed during the reaction. This alkylation process is effected in closed vessels of copper or cast-iron at a temperature of 80° to 100° C. produced by steam or a water bath.

Methyl Violet is the hydrochloride of penta-methyl-pararosanine, having the formula $C_{24}H_{28}N_3Cl$, or—

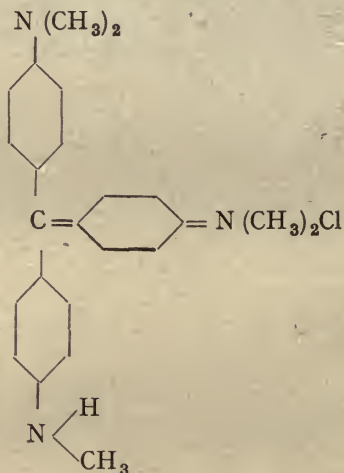

It is manufactured by the direct oxidation of dimethylaniline, the process being usually carried out by heating together, at a temperature slightly above atmospheric, 10 parts of dimethylaniline, 3 parts of cupric nitrate, 2 parts of sodium chloride, 1 part of weak acetic acid, and 100 parts of sand, the latter rendering the melt porous to allow free access of air to

all parts thereof. The melt is placed in the form of cakes in a hot chamber until hard and brittle. They contain the violet as an insoluble compound with cuprous chloride, and are subsequently powdered, the soluble substances being extracted with water, and the double salt of the violet and cuprous chloride decomposed.

According to one method, the powdered melt is boiled with dilute sulphuric acid, and filtered to free it from sand. Violet sulphate is then precipitated with sodium sulphate, and washed, redissolved, and reprecipitated as the chloride with common salt.

Iodine Green ($C_{27}H_{35}N_3I_2$) is the methyl ammonium derivative of hexamethylrosaniline, having the structural formula—

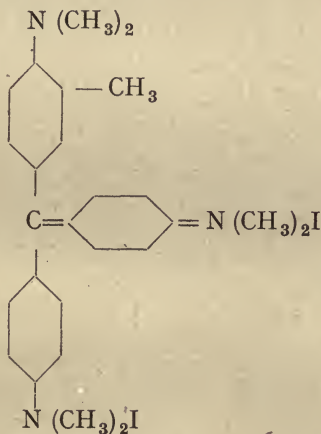

It is prepared by heating Hofmann's Violet with methyl iodide in a methyl alcohol solution in closed vessels at a temperature of 120°C . and a pressure of ten to twelve atmospheres. The product is dissolved in water, and agitated with amyl alcohol to dissolve out

the unused violet. The green is then precipitated with zinc chloride and common salt.

Victoria Blue B. ($C_{33}H_{32}N_3Cl$) is best represented by the formula—

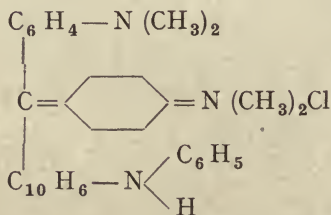

It may be prepared by mixing 10 parts of tetramethyldiaminobenzophenone, 9 parts of naphthylphenylamine, and 7 parts of phosphorous trichloride. A reaction commences immediately, and heat is subsequently applied up to $110^\circ C.$, the product being dissolved in water, and the dye precipitated with salt.

Aniline Blue is a pure blue obtained by introducing phenyl-groups into rosaniline chloride, its chemical name being triphenylrosaniline chloride, having the formula—

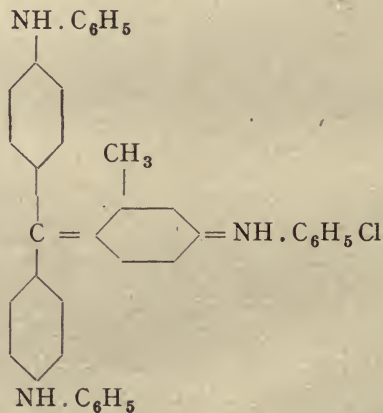

It is manufactured by heating rosaniline acetate with aniline, a temperature of 180° C. being maintained for several hours. The product is extracted with dilute hydrochloric acid, and the chloride precipitated with the concentrated acid. The dye is a nearly black substance insoluble in water, but freely soluble in alcohol to a dark blue solution, which dyes wool and silk a pure blue.

Another group of triphenylmethane dye-stuffs is produced by substituting hydroxyl-groups for the amino-groups in rosaniline. The most important dye of this group is **Chrome Violet**, which is prepared by the action of formaldehyde upon a solution of salicylic acid in sulphuric acid. It has the formula—

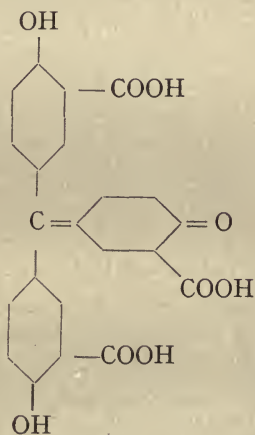

Owing to the fact that the substituted radicals are in ortho-position, the dye-stuff is capable of entering into combination with metallic mordants of the iron group, and especially with a chrome mordant,

producing a fast violet on cotton. It is chiefly used in printing cotton.

One other dye-stuff of this group is worthy of mention, namely, **Phenolphthalein**, which is obtained by heating phenol with phthalic anhydride and concentrated sulphuric acid. This step in the process takes several hours, the product being boiled with water to remove phthalic and sulphuric acids, and distilled with steam to remove the excess of phenol. The insoluble portion is then treated with dilute caustic soda to extract the phthalein, which is precipitated from the crimson solution with acetic acid. Phenolphthalein has the formula—

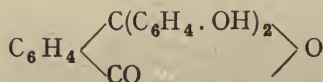

or $\text{C}_{20}\text{H}_{14}\text{O}_4$, and is useless as a dye owing to the fact that the colour cannot be fixed; but as it forms a deep crimson solution when dissolved in alkalis, it is employed largely as an alkali indicator in volumetric analysis.

The last group of phenylmethane dyes to be considered is that known as the Pyrone-group. Chromogens containing the pyrone ring combined with the structure of the triphenylmethane derivatives give some of the most beautiful dye-stuffs which modern science has placed at the disposal of the textile industry.

Fluorescein ($\text{C}_{20}\text{H}_{12}\text{O}_5$) is prepared by mixing phthalic anhydride and resorcinol in molecular proportions and heating to 190°C . in enamelled iron pots in an oil bath. The ingredients melt, steam being evolved, and the mass subsequently solidifies into a dark brown cake of nearly pure fluorescein.

The reaction may be explained by stating that two molecules of resorcinol combine with one molecule of phthalic anhydride, at the same time interacting with one another, losing one molecule of water, and forming the pyrone ring. This reaction may be expressed—

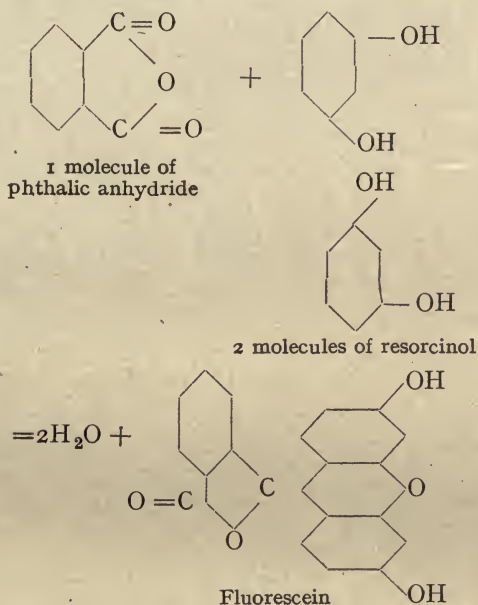

Abstracting the pyrone ring from this formula, it may be expressed thus—

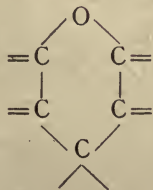

Fluorescein is a dark-red crystalline substance insoluble in water, but soluble in alcohol and alkalis. A solution of its alkali salts in water possesses a beautiful green fluorescence, hence its name. The alkali salts dye wool and silk yellow, as does fluorescein itself, the shade produced by the latter possessing a greenish fluorescence, but the colour is not fast to light.

The disodium salt of fluorescein ($C_{20}H_{10}O_5Na_2$) is sold under the name of **Uranin** in the form of a yellow powder soluble in water, used for dyeing pale yellow shades on silk.

Eosine is tetra-bromofluorescein ($C_{20}H_6O_5Br_4K_2$), and is prepared by the action of 4 parts of bromine on one part of fluorescein. The bromine is first dissolved in caustic soda and evaporated to dryness, being subsequently dissolved in water and mixed with the theoretical quantity of fluorescein dissolved in caustic soda. The product is acidified with hydrochloric acid, and to purify the eosine it is dissolved in a solution of potassium carbonate, forming its potassium salt, from which it is liberated with dilute sulphuric acid and extracted with ether. Eosine, a halogen substitution product of fluorescein, is a strong dibasic acid, forming reddish-yellow crystals, and is practically insoluble in water. It has the formula—

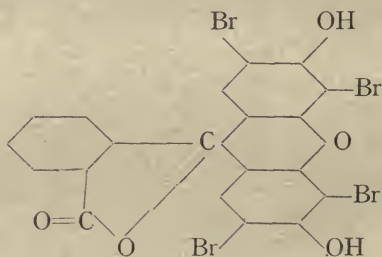

Eosine dyes wool, silk, and alumina-mordanted

cotton a delicate pink, hence its name, which is derived from a Greek word meaning dawn.

The alkali salts of **Eosine** are strong and stable, and, under the name of **Water-Eosines**, are used in the paper-making industry, as the fibre being mordanted during sizing readily takes up the dye without further treatment.

Erythrosin is the sodium salt of tetraiodofluorescein and has the formula $C_{20}H_6O_5I_4Na_2$. It is prepared by treating fluorescein with iodine, and oxidising agents such as mercuric oxide, iodic acid, and cupric chlorate. It dyes silk more bluish shades than **Eosine**, but it finds an exceedingly important application in the photographic industry.

Erythrosin holds first place as a sensitiser of silver bromide, and is used largely in the production of orthochromatic dry plates.

Rhodamine B. ($C_{28}H_{31}N_2O_3Cl$) is an amino substitution product of fluorescein, and, among other methods, may be prepared from that substance by treating it with phosphorous pentachloride. When the latter is heated with diethylamine under pressure, **Rhodamine** is formed, having the formula—

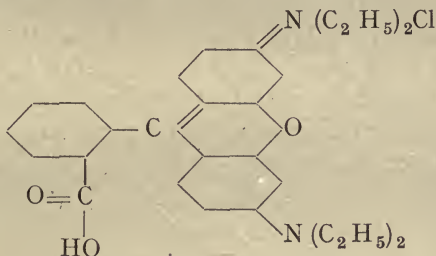

Rhodamine, a basic dye, is one of the most beautiful colouring matters ever prepared, and dyes wool, silk, and tannin-mordanted cotton a brilliant pink.

A number of **rhodamine** derivatives are dye-stuffs, of which the following are typical :

Rhodamine G. ($C_{26}H_{27}N_2O_3Cl$), or tri-ethyl-rhodamine, is prepared by heating **Rhodamine B.** with aniline hydrochloride, and dyes wool and silk red with a more yellowish tinge than **Rhodamine B.**

Rhodamine 3 B. or **Anisoline** is an alkylated rhodamine, and dyes a little more bluish than **Rhodamine B.**, but more brilliant and pure.

Two other dye-stuffs containing the pyrone ring in their formulæ will now be considered. The first of these is **Galleine** ($C_{20}H_{12}O_7$), which is prepared from phthalic anhydride and pyrogallol, and is represented by the structural formula—

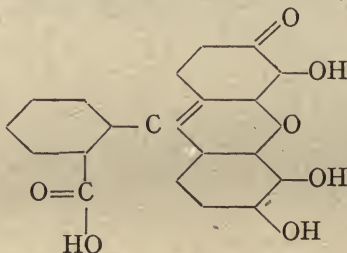

It dyes mordanted wool and cotton, giving dark violet shades with chrome mordants.

Coeruleine ($C_{20}H_8O_6$) is obtained by heating **galleine** with concentrated sulphuric acid to $200^\circ C$. It dyes wool and cotton a fast olive green with chrome mordants, and is extensively used in cotton printing. It has the structural formula—

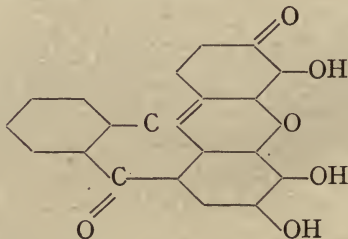

With this dye-stuff our rapid survey of the phenylmethane derivatives must come to an end, but it is thought that enough has been described to give an idea of the wonderful range of shades which has been opened up to dyers and printers of textile goods by the discovery of these products. Unlike such dyes as indigo and alizarin, these triphenylmethane derivatives were unknown to mankind altogether, until the perseverance of chemists not only produced them, but, what is far more important, rendered their manufacture possible on a commercial scale.

Many of these dyes are of German origin, and at the present time a number of prominent English chemists are engaged in research work which it is hoped will result in the permanent establishment of the manufacture of the bulk of these valuable dye-stuffs in this country.

CHAPTER VII

AZINE AND HETEROCYCLIC RING DYES

A LARGE number of very important dye-stuffs are included in what may be termed the heterocyclic ring dyes, and are divided into groups or classes according to the constitution of their characteristic ring. As there is considerable similarity between these groups of dye-stuffs, it will be most convenient, for the purpose of simple explanation in a book of this kind, to consider them in a single chapter under suitable sub-headings. Before, however, passing to the consideration of the first of these groups—the azine dyes—it may be explained that a heterocyclic ring is one which, unlike the nucleus of the benzene ring, is made up of atoms of different elements, the ring being usually, but not necessarily, a six-membered one.

I. AZINE DYES.

The azine ring is composed of four carbon atoms and two nitrogen atoms, the latter being arranged in para-position with respect to each other, the ring being, therefore, represented by the formula—

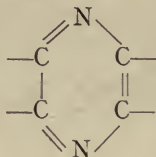

Now it will be noticed that each atom in this ring is linked to its neighbouring atoms by triple bonds, or, in other words, three valencies of each atom are utilised in linking the several component atoms together in the ring. But carbon is a tetravalent element; that is to say, one atom of carbon can combine with four atoms of a mono- or univalent element to form one molecule of a new compound, such, for instance, as methane (CH_4), whilst nitrogen is normally a trivalent element. It will be obvious, then, that all the nitrogen valencies are occupied in linking these atoms to the carbon atoms of the ring, whilst the carbon atoms themselves each have one free valency remaining, which can be satisfied by an atom of a univalent element or a radical.

The simplest azine compound thus consists of an azine ring plus four atoms of a univalent element, and in the case of this latter being hydrogen, the compound formed is known as pyrazine, and has the formula $\text{C}_4\text{N}_2\text{H}_4$, or—

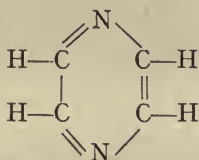

This compound, however, does not show the characteristic properties of the azines, these only becoming apparent when the azine ring is linked to at least one other ring of the aromatic series, in such a manner that two of the carbon atoms of the azine ring form part of the aromatic ring. Phenazine, the simplest compound

of this type, clearly shows this molecular structure, its formula being—

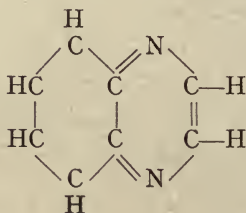

or $C_8H_6N_2$.

The remaining two carbon atoms of the azine ring may also form part of a second aromatic ring, thus forming diphenazine, a substance from which many of the azine dyes are obtained, and which has the formula—

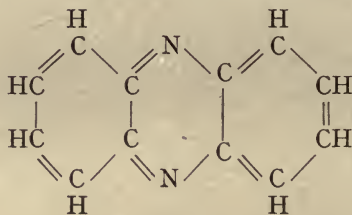

or $C_{12}H_8N_2$.

Although they possess strong chromogenic properties, the simple azines, such as diphenazine, are not in themselves dye-stuffs, but only become useful as such when auxochromic, or salt-forming groups, such as the amino- or phenolic-groups, are introduced into the nuclei of the azine compound. The azines are strongly basic substances, usually of crystalline form, and varying in colour from white to orange. They are very stable, and possess high melting and boiling points, and form highly-coloured salts with mineral acids. These salts, however, in spite of their colouration, are

useless as dye-stuffs and are readily hydrolysed by water to free acid and free base. When converted into dye-stuffs by the introduction of auxochromes, and also when in the form of their salts, the azines have the quinonoid or quinoxaline form shown in the formula we have given for diphenazine; but in its free state diphenazine exists in a tautomeric form, having a symmetrical structure which accounts for its great stability.

This tautomeric form is represented by the formula—

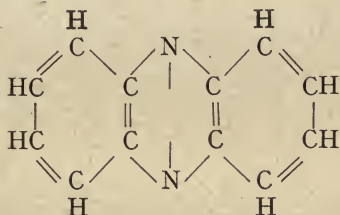

From this formula it will be seen that the third valency of the nitrogen atoms is occupied in linking these atoms to each other instead of forming a double bond between the adjacent carbon atoms. In a compound such as diphenazine, the azine ring, owing to its position, is known as the "meso" ring, and the names of the radicals attached to it are prefixed to the word "azine," in order to designate the compound formed.

Besides the method of converting azines into dye-stuffs by the introduction of auxochromes into their nuclei, there is another method of producing azine dyes which consists in first converting the simple azines into what are known as "azonium bases," and then introducing auxochromes as before.

The azonium bases are, at present, not fully understood, but they are formed by treating azines with a substance containing an organic radical, which latter, together with an acid radical, attaches itself to one of the nitrogen atoms of the azine ring, the nitrogen atom in consequence becoming pentavalent instead of trivalent. The following example showing the formula for a typical azonium base will make their molecular structure clear—

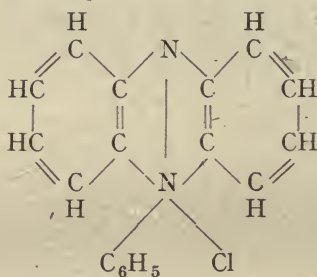

It will thus be seen that one of the nitrogen atoms is linked to three organic radicals, and an acid radical by four of its valencies, the fifth being utilised to maintain its connection with the other nitrogen atom of the ring. Like the azines themselves, the azonium bases are not dye-stuffs, although they are highly coloured substances, but their chromogenic properties are developed, so as to make them useful as dye-stuffs, by the introduction of auxochromes, as in the case of the azines.

The azine dye-stuffs are sub-divided into the following groups, viz. : Eurhodines, which are amino derivatives of azines ; Eurohodols, which are phenolic derivatives of azines ; Safranines, amino derivatives of azonium bases ; Safranols, which are the corresponding phenolic derivatives of azonium bases ; Rosindulines,

or naphthophenazine compounds; and Indulines, which are aryl- and alkyl-poly-amino-azines.

Various methods are known for producing the simple azines, but it will be sufficient if we consider two of these by way of example.

According to one method, diphenazine is produced by the reaction of orthodihydroxyl compounds with orthodiamines, the hydro derivative of the diphenazine thus produced being converted into the pure azine by oxidation. Taking, as our orthodihydroxyl compound, a benzene derivative known as pyrocatechol, having the formula—

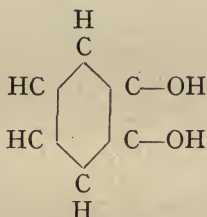

and, as our orthodiamine, *o*-phenylenediamine, which has the formula—

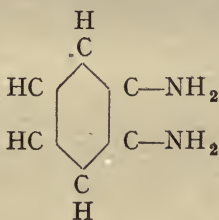

it will readily be seen that when these two substances react together in the presence of one atom of oxygen for each molecule of the reacting compounds, the hydrogen and oxygen contained in the amino- and

130 AZINE AND HETEROCYCLIC DYES

hydroxyl-groups of the pyrocatechol and *o*-phenylenediamine, together with the oxygen employed for oxidation, unite to form three molecules of water, thus leaving the two benzene nuclei free to unite with the two nitrogen atoms contained in the diamine, so as to form diphenazine. The following equation expresses the reaction which occurs—

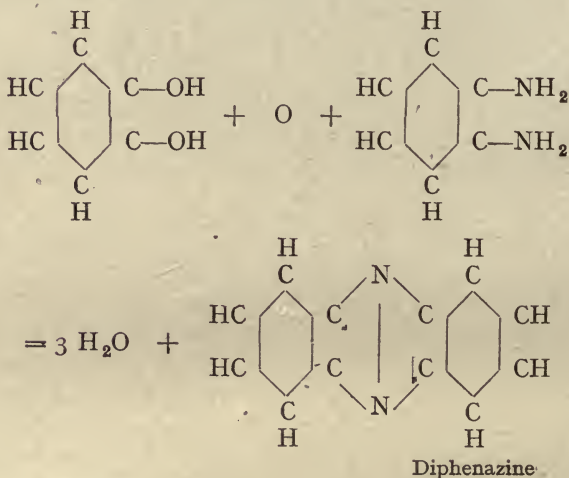

A method of producing azines, which is widely used, consists in the action of alpha- or ortho-diketones (a ketone being a substance containing the radical CO) on aromatic orthodiamines. A simple example illustrating this method is the production of phenazine from glyoxal, a diketone having the formula—

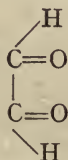

and ortho-phenylenediamine. In this instance two

molecules of water are formed together with phenazine according to the equation—

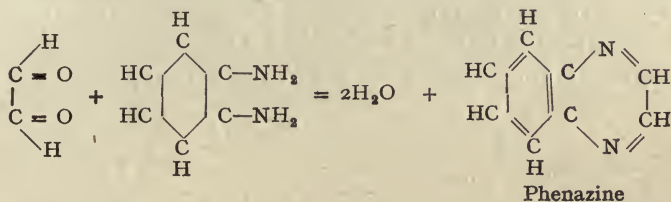

The simplest azine dyes are the amino derivatives of the simple azines, which, as we have already mentioned, are known as eurhodines. The simplest eurhodine is made according to a general process, which consists in the reaction of an orthoaminoazo compound with the hydrochloride of an aromatic monamine under the influence of heat, the monamino compound being employed in phenolic solution. To form this simplest eurhodine, which has the formula $\text{C}_{17}\text{H}_{13}\text{N}_3$, equal molecular parts of orthoaminoazotoluene and α -naphthylamine hydrochloride dissolved in phenol are heated to a temperature of 130°C ., until the emerald green colour of the mixture changes and becomes a bright scarlet, when an excess of toluene is added to the mixture and precipitates the hydrochloride of the eurhodine. The free eurhodine is obtained from its salt by precipitation with ammonia or an alkali, and the resulting yellow powder is crystallised from aniline and forms silky yellow prisms and brown needles.

A characteristic feature of eurhodine, and the series of dye-stuffs to which it belongs, is the beautiful and striking fluorescence produced when it is dissolved in ether. Eurhodine is a bright scarlet dye, but is not used commercially, as the colour it imparts to the fabric is not fast, and turns yellow when the fabric is washed.

A good example of an eurhodine dye is **Neutral**

132 AZINE AND HETEROCYCLIC DYES

Red, which is formed by the decomposition of an indamine. An indamine is a compound which consists of an imino compound (containing the imino radical NH), linked by means of a nitrogen atom to an amino compound, as shown in the formula—

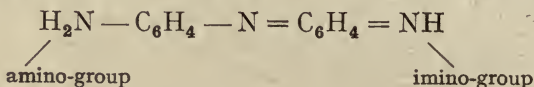

or expressed structurally—

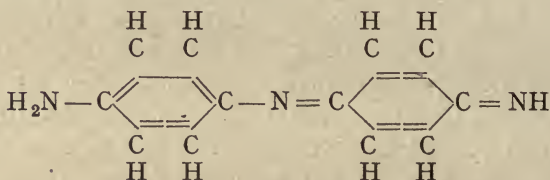

It will be observed from the latter formula that the imino portion of the molecule is quinonoid in form; the indamines, therefore, possess dyeing properties, but they are too unstable for commercial use, and are therefore only used for producing azine dyes. The particular indamine employed in the production of neutral or tolylene red is Tolylene Blue, which is the product resulting from the action of para-nitrosodimethylaniline hydrochloride—

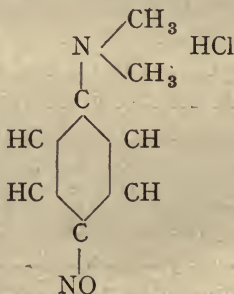

upon meta-tolylenediamine—

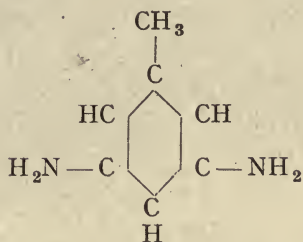

Tolylene blue has the quinonoid structural formula—

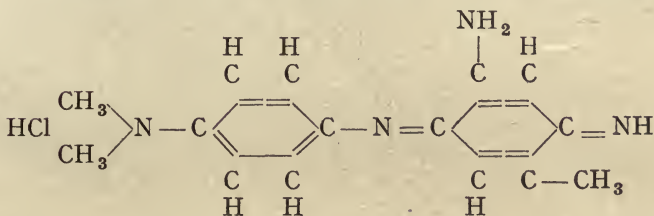

and when this substance is boiled it is decomposed, forming as the principal product dimethyldiaminotoluphenazine hydrochloride, or neutral red, having the formula—

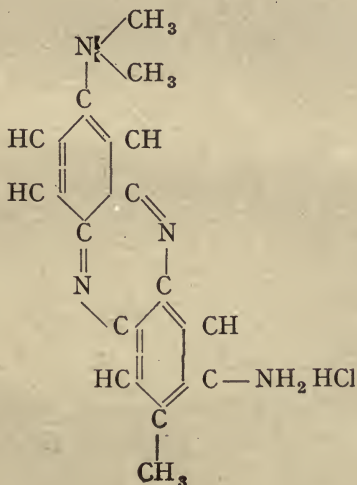

This substance is a dark red powder, which is soluble in water and is a direct cotton dye. It is largely used for calico printing and produces very fast shades, which may be varied from pink to a coppery red.

If, instead of using meta-tolylene-diamine and para-nitrosodimethylaniline for producing an indamine, meta-phenylenediamine is used together with a para-diamine, such as para-amino-dimethylaniline—

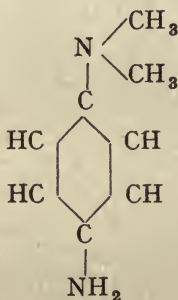

and the indamine thus formed is boiled as before **Neutral Violet**, another eurhodine dye, is produced and has the formula—

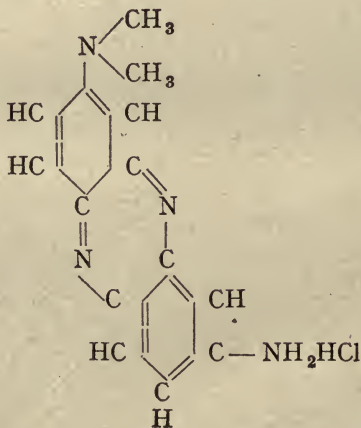

These two dye-stuffs are representative examples illustrating a general method for the production of eurhodines.

Eurhodols, it will be remembered, are phenolic, or hydroxyl, derivatives of azines, and may be produced in several ways. If naphthaphenanthrazine- α -sulphonic acid ($C_{24}H_{13}N_2SO_3H$) is fused with caustic potash (KOH), or caustic soda (NaOH), phenanthranaphthaurhodol is produced, having the formula $C_{24}H_{13}N_2OH$. This substance is too costly to produce so as to enable it to be used commercially. It is a yellow dye for mordanted cotton, and its production by the fusion of the sulphonic acid of an azine with a caustic alkali is representative of a general method for producing eurhodols. Other methods of producing eurhodols consist in hydrolising eurhodines by heating them with concentrated acids under pressure, and in boiling diazo azine compounds with water.

The most important dye-stuffs derived from the azonium bases are the Safranines. The most widely used method for producing these dye-stuffs is that which consists in oxidising a diamine compound and an aromatic monamine, in the proportions of one molecular part of the former and two molecular parts of the latter. This method is similar to that which we have described for the production of neutral red, and, as in that process, intermediate products are formed during the reaction, these being unstable indamines. If the formula for indamine is referred to, it will be seen that compounds of this character are para-compounds, the amino- and imino-groups and the linking nitrogen atom being attached to the rings at the top and bottom positions. It will, therefore, be obvious that in order to enable an indamine to be formed as an intermediate product in the process for

producing safranines, one of the two molecules of a monamine which are used must have the para-position, with respect to the amino-group, free; whilst, as azines, and consequently azonium bases, are ortho-compounds, the second molecule of monamine must have a free ortho-position. This will be clearly understood when we consider specific examples illustrating the process. Safranines are diamino derivatives of azonium bases, so that, instead of oxidising a diamine with a monamine, the diamine may be replaced by an aminoazo compound or a nitroso compound, but if the latter is used it has to be reduced in the course of the process so as to convert the nitroso-group (NO) into an amino-group, or enable its nitrogen atom to be utilised in forming the chromophoric azine-group.

Phenosafranine, which is a very beautiful pink dye for wool, silk, and cotton, is a typical example of its class, and is manufactured according to the general method already referred to. A dilute solution, in water, of paraphenylenediamine hydrochloride—

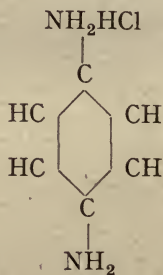

and aniline hydrochloride—

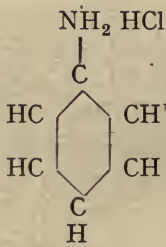

which is, of course, the monamine component, is boiled, and manganese dioxide, or bichromate of potash or soda, is then added in order to effect the oxidation. This is the first stage in the process, and results in the formation of indamine, which is immediately converted into the safranine by the continued oxidation in the presence of the second molecule of monamine. The following equation, on page 138, represents the reaction in which phenosafranine is produced, together with four molecules of water.

The impurities contained in the liquid after the oxidation has been completed are removed by precipitation with chalk, or soda solution, and filtration, and the salts of the safranine are extracted by suitable treatment with acids, usually nitric or hydrochloric, and a nitrate or chloride. The salts so obtained are recrystallised, either from water or alcohol, so as to obtain the safranine in pure form. If the process is carried out carefully it is possible to obtain a yield of pure safranine of approximately 70 per cent. of the theoretical yield.

Basle Blue is a beautiful blue safranine dye-stuff, which is produced according to the process just described, by the action on the paratolynaphthylenediamine, which is produced by heating together paratoluidine hydrochloride and dihydroxynaphthalene, of nitrosodimethylaniline. It has the formula $C_{32}H_{29}N_4Cl$, and is a brown crystalline powder.

Methylene Violet, another safranine dye, is the product of the oxidation of paranitrosodimethylaniline—

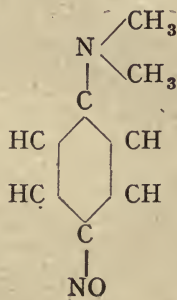

with two molecules of aniline hydrochloride, the formula for this dye-stuff being—

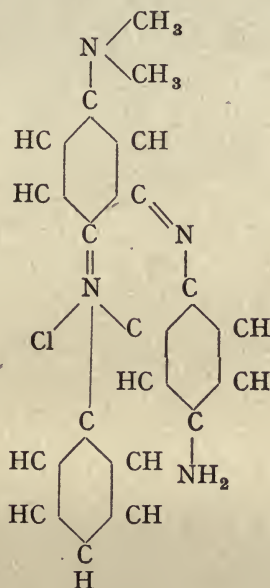

Azine Green, also a safranin, is the product of the reaction between nitrosodimethylaniline hydrochloride and 2-6-diphenylnaphthylenediamine, and has the formula $C_{30}H_{25}N_4Cl$.

Induline Scarlet is not a member of the induline series as its name would imply, but is really a fine red safranin dye, which is manufactured according to the process described for the production of eurhodine by melting anilinazoethylparatoluidine with α -naphthylamine.

Amethyst is a beautiful but fugitive violet dye-stuff, and may be either tetramethyl- or tetraethyl-safranin.

It is manufactured by oxidising, in the manner previously described, paraphenylenedimethyl- (or diethyl) diamine, and one molecular part of dimethyl- (or diethyl) aniline, and one molecular part of aniline.

Magdala Red is a naphthalene safranine dye used for dyeing silk a beautiful pink colour. It is manufactured by heating together α -naphthylamine acetate and α -aminoazonaphthalene, which forms a magenta melt, to which para-naphthylenediamine is added in order to increase the yield of the dye-stuff, which would otherwise be small. This melt is treated several times with boiling water to extract the dye, which separates from the solution when cool, and is subsequently recrystallised from water. This dye-stuff has the formula $C_{30}H_{21}N_4Cl$, and is insoluble in cold water.

Indoin Blue is a basic dye largely used for calico printing and for dyeing cotton, and is produced by diazotising one of the amino-groups of phenosafranine and coupling with β -naphthol.

Mauveine, the first artificial dye-stuff to be discovered, is phenylphenosafranine and therefore has the formula—

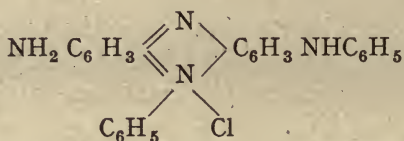

It was formerly prepared by the oxidation of impure aniline by potassium dichromate, but is now manufactured by oxidising diphenylmetaphenylenediamine and paraphenylenediamine, or alternatively, meta-aminodiphenylamine and para-aminodiphenylamine may be used. It is insoluble in cold water, and is very fast to light and washing. It is used for paper printing

to some extent, and also for shading bleached silk. The commercial substance is a violet paste, and is known as Rosolane.

Aposafranine is a red dye-stuff which is a monamino derivative of an azonium base. It is, however, of little importance, but is interesting as being akin to the indulines.

Induline, which, together with **Nigrosine**, is used for making inks, is a mixture of arylaminoazines, and is manufactured by heating together aminoazobenzene, aniline, and aniline hydrochloride. It contains di-, tri-, and tetra-arylaminoazine compounds, which are, mesophenyl-dianilinoaminodiphenazonium chloride—

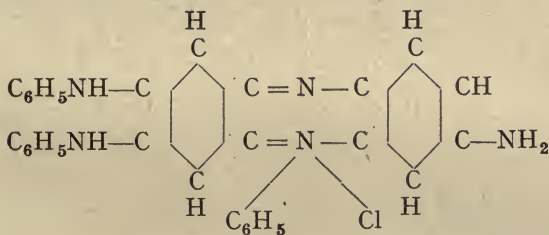

mesophenyl-trianilinophenazonium chloride—

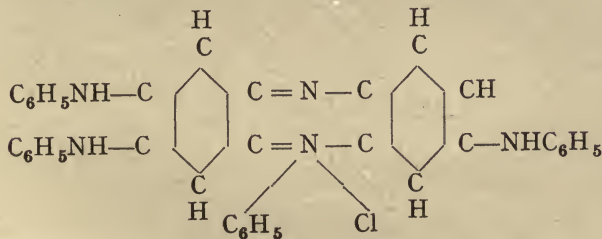

142 AZINE AND HETEROCYCLIC DYES

and mesophenyl-tetraanilinophenazonium chloride—

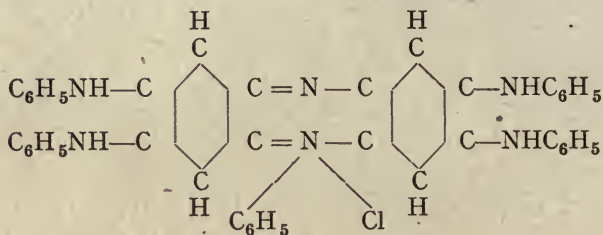

Flavinduline, a yellow dye-stuff, is manufactured by heating phenanthraquinone—

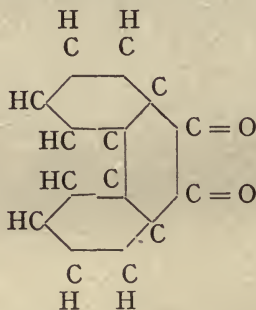

and *o*-aminodiphenylamine—

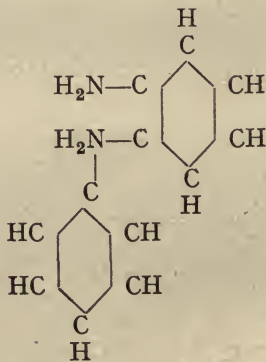

together, and treating with hydrochloric acid. This dye-stuff has the formula—

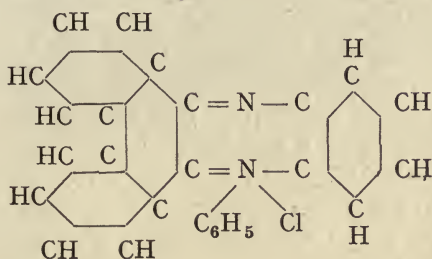

II. OXAZINE DYES.

The members of this group of dye-stuffs are characterised by the six-membered oxazine ring—

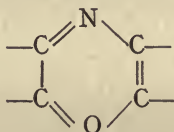

which, as in the case of the azines, forms part of other aromatic rings in the dye compounds themselves. Although the molecular constitution of the oxazines has not been finally determined, they are now generally considered to be ortho-quinonoid compounds, with which salts are formed by the linking of an acid radical to the oxygen atom of the ring, this atom thereby becoming tetravalent. Compounds of this nature are known as oxonium compounds, and those of them which are dye-stuffs are usually divided into two main groups, according to whether they are basic or mordant dyes.

The members of the basic group are, as a rule, hydrochlorides or sulphates of oxazines, although a

number of them are double salts, as, for instance, the zinc chloride of an oxazine.

Meldola's Blue is an example of an oxazine double salt dye-stuff, and is manufactured in the following manner. An alcoholic solution of nitrosodimethylaniline hydrochloride and β -naphthol, in the proportions of two and a half parts of the former to one of the latter, is placed in a reflux apparatus consisting of a flask and an inverted condenser which returns the condensed liquid to the flask, and boiled for a day. The dye-stuff forms as a chloride in the boiled solution, from which it is precipitated by means of zinc chloride solution; the dye-stuff, which when dried is a dark violet soluble powder, is therefore a zinc chloride double salt. The yield of dye-stuff is about 40 per cent. by weight of the total quantity of the starting components. Commercial Meldola's Blue contains a small quantity of New Blue R., this being due to the fact that, in the process of manufacture, one-third of the nitrosodimethylaniline employed undergoes reduction, forming a compound known as asym-dimethyl-*p*-phenylenediamine, which, when condensed with Meldola's Blue, forms New Blue R. The method of manufacturing Meldola's Blue, which is an indigo blue dye for mordanted cotton, is representative of a general process for producing oxazine dyes, and the method of its formation is shown by the following equation—

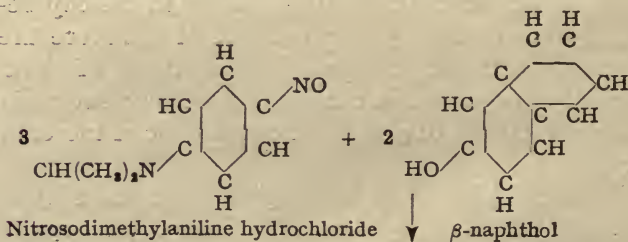

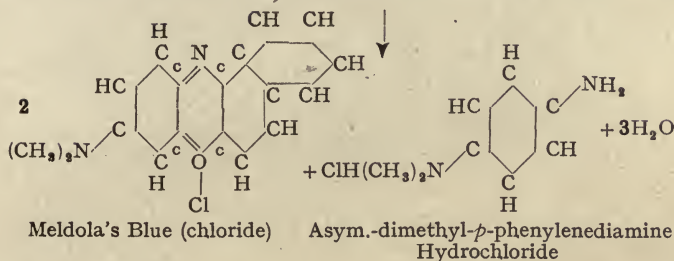

Nile Blue A., a bright blue dye-stuff for tannin-mordanted cotton, is produced by another process from α -naphthylamine and nitrosodiethyl-*m*-amino-phenol.

According to this process, a 10 per cent. solution of α -naphthylamine hydrochloride in glacial acetic acid (20 per cent. H₂O) is heated to boiling-point in a vessel connected to a condenser, and a quantity of nitrosodiethyl-*m*-aminophenol, equal to about twice the weight of α -naphthylamine hydrochloride used, is then fed into the vessel. The reaction which ensues is vigorous, and the nitrosodiethyl-*m*-aminophenol is therefore introduced slowly, a sufficient interval elapsing between the feeds to allow the reaction from the previous feed to subside. The contents of the vessel are allowed to boil for half an hour after the whole of the necessary quantity of the phenol compound has been fed in, and it is then allowed to cool, when the dye-stuff crystallises out, forming a bronze powder, which is soluble in water. The equation representing the reaction is as follows—

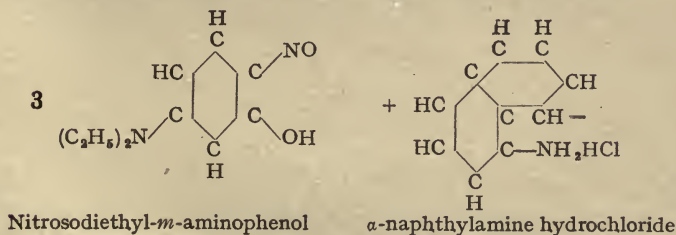

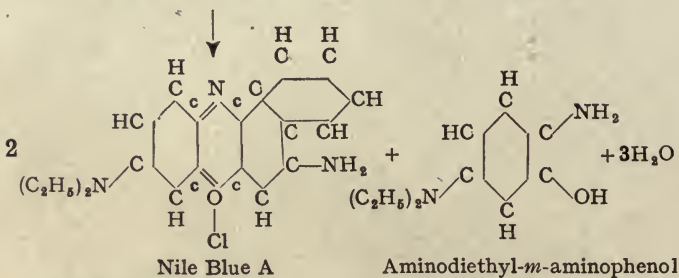

New Methylene Blue is a greenish blue dye-stuff used for dyeing mordanted cotton and silk, to which it imparts very fast colours. It is manufactured by condensing dimethylamine with Meldola's Blue, and has the formula—

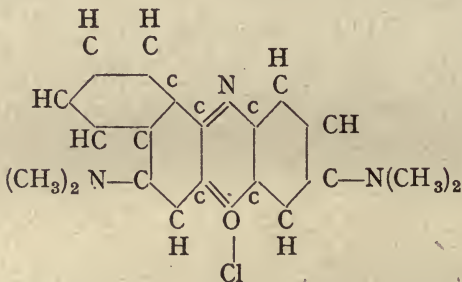

The members of the second main group of oxazine dyes are known as the mordant colours, because they form insoluble lakes with metallic salts when the latter are used as mordants, and in this respect they resemble alizarin. They are produced by condensing gallic acid—

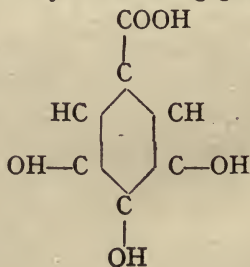

or its derivatives, with nitroso or aminoazo compounds.

Galloyanine is the most important of this series, and is manufactured from nitrosodimethylaniline and gallic acid. An alcoholic solution containing about 12 per cent. by weight of a mixture of gallic acid and nitrosodimethylaniline hydrochloride in the proportions of one part of the former to 1.7 parts of the latter, is heated in a reflux apparatus for some time. As soon as a test sample of the mixture, when placed on filter paper, produces a dark violet stain which is not surrounded by a ring of yellow, the alcohol is distilled off from the vessel containing the mixture, the residue left being then boiled in water, filtered, and dried. This dye-stuff is an insoluble bronze powder, and is used for dyeing bluish-violet shades on chrome-mordanted wool and cotton. Its formation takes place in accordance with the following equation—

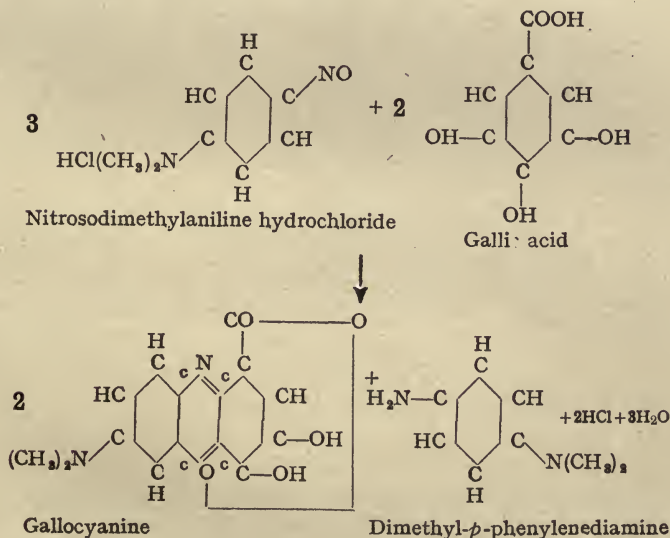

Prune is a dye of the gallocyanine type, which is manufactured by a similar process to that just described. In the production of this dye, however, gallic acid is replaced by methylgallate.

Celestine Blue B. is another dye-stuff belonging to this series, and is manufactured from nitrosodiethylaniline and gallimide.

The sulphonic acids of gallocyanines also form dye-stuffs, as, for instance, **Delphine Blue**, which is the sulphonated product of the reaction between aniline and gallocyanine hydrochloride when these two substances are condensed together.

Indalizarin is a dye-stuff formed by the action of sulphites on gallocyanine sulphonic acid, and is representative of a series of dyes produced in a similar manner, and known as Chromocyanines.

Another series of dye-stuffs known as Phenocyanines is produced by reacting on gallocyanines with resorcin.

Phenocyanine VS. is produced in this manner from resorcin an diethylgallocyanine, which is the diethyl compound corresponding to ordinary gallocyanine, the formula for which has already been given.

Phenocyanine TC. is produced by the oxidation in air of Phenocyanine VS., and has the formula—

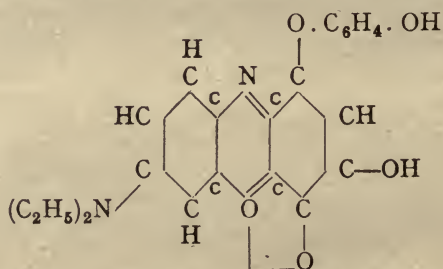

Phenocyanine TV. is produced by sulphonating Phenocyanine TC., and with the other similar dyes just

described is used for dyeing blue to violet shades on chromed wool.

Muscarine is an oxazine dye of the naphthalene series, and has the formula—

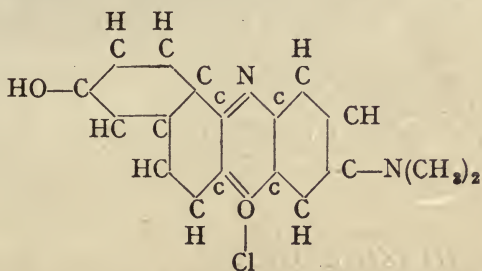

It is the product resulting from the action of nitrosodimethylaniline on 2-7-dihydroxynaphthalene—

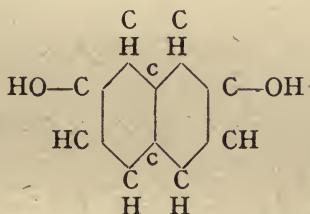

and dyes tannin-mordanted cotton blue.

Fast Green M. is produced from muscarine by treatment with aniline. It is a very fast green used for tanned cotton printing.

Fast Black is an interesting dye-stuff, as its constitution is that of a combined azonium and oxonium compound. It is manufactured by condensing *m*-hydroxydiphenylamine with nitrosodimethylaniline, and has the formula which is given on the next page—

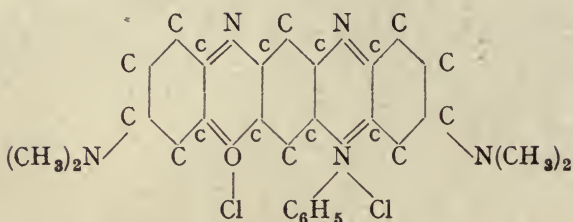

It is a blue-black dye for mordanted cotton, the colour imparted to the fabric being very fast to light and washing.

III. THIAZINE DYES.

These dye-stuffs also possess a six-membered meso-ring, and are generally formulated as para-quinonoid compounds; the ring, therefore, may be written thus—

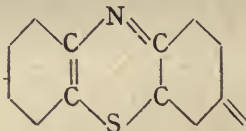

The most important member of the series is **Methylene Blue**, which is a basic dye of great fastness and considerable commercial importance. The process for its manufacture is somewhat involved, and is carried out in three operations. In the first place a solution of about 47 gallons of *p*-aminodimethylaniline hydrochloride is prepared from a suitable quantity of dimethylaniline dissolved in weak hydrochloric acid, and treated with sodium nitrite, which converts the dimethylaniline into nitrosodimethylaniline hydrochloride, which is then reduced to the amino compound

by means of zinc dust and hydrochloric acid. This solution is neutralised with sodium hydroxide at a temperature not exceeding 20° C., and about 32 lbs. of sulphate of aluminium is added to it, the mixture being then thoroughly stirred in an agitated pan for half an hour. When this has been done, a concentrated solution of about 26 lbs. of sodium thiosulphate ($\text{Na}_2\text{S}_2\text{O}_3$) is rapidly run into the mixture, and this is followed by about 16 gallons of a 10 per cent. aqueous solution of potassium dichromate ($\text{K}_2\text{Cr}_2\text{O}_7$), and the mixture again agitated for one hour. By this means a thiosulphonic acid is formed as follows—

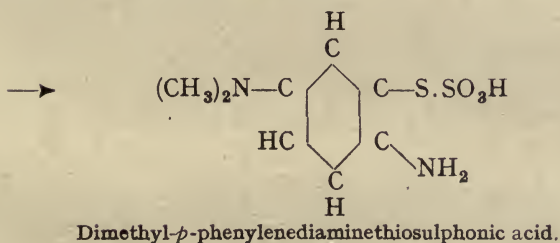
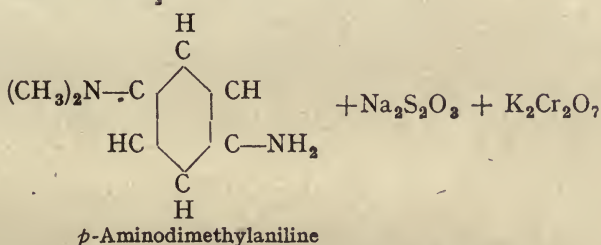

The mixture from the first operation is diluted to bring the quantity to 130 gallons, when about 13 lbs. of dimethylaniline hydrochloride are added to it. A saturated solution of 30 lbs. of potassium dichromate is then rapidly run into the mixture, while the latter is kept well agitated.

152 AZINE AND HETEROCYCLIC DYES

The oxidation of the thiosulphonic acid and dimethylaniline hydrochloride thus effected produces an indamine, as follows—

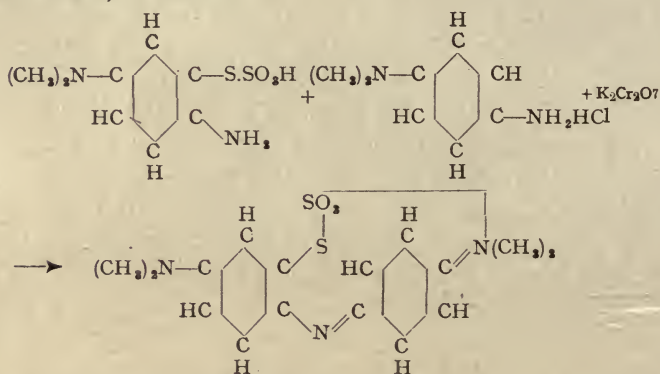

and, on boiling the mixture for half an hour, with the addition of a solution of about 165 lbs. of zinc chloride, the indamine is oxidised, first to the leuco-base of the dye—

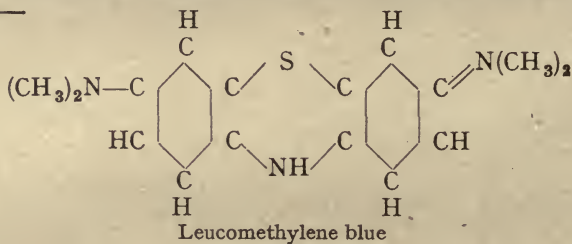

and then to the dye itself—

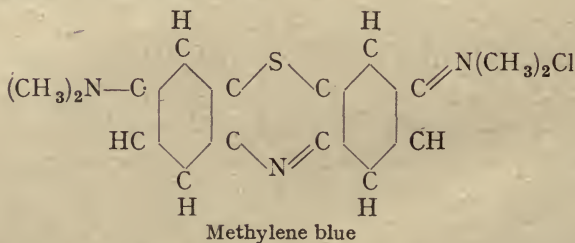

The dye-stuff is precipitated in the boiled mixture, which, when cool, is filtered, the separated dye being then redissolved and precipitated by means of zinc chloride in order to purify it. Methylene blue is extensively used for dyeing cotton yarns, on which it produces greenish-blue shades with tannin mordants. It is also used for calico printing, and is often shaded with other basic dye-stuffs. Its bacteriological uses are referred to in Chapter IX.

Methylene Green. If methylene blue is dissolved in sulphuric or acetic acid and the solution is treated with nitric or nitrous acid, a mono-nitro derivative is formed which dyes mordanted cotton bluish-green shades, and is therefore known as methylene green.

Gentianine is a bluish-violet dye for mordanted cotton, and is also used for bacteriological and histological work. It is manufactured by oxidising *p*-phenylenediamine with dimethyl-*p*-phenylenediamine in the presence of hydrogen sulphide, and has the formula—

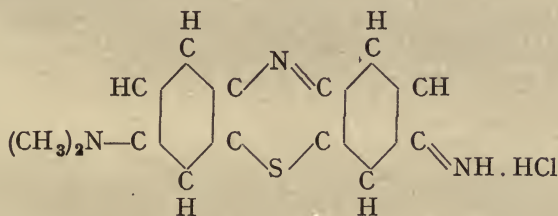

The commercial product is, however, the zinc chloride double salt of the dye-stuff, and is a soluble reddish-brown powder.

New Methylene Blue N. is also a dye for tannin-mordanted cotton, and gives more purple-blue shades than methylene blue. The general process for its

manufacture is similar to that employed in making methylene blue, and consists in oxidising *p*-aminoethyl-*o*-toluidine in the presence of sodium thiosulphate, thus forming ethyl-*p*-tolylene-diaminethiosulphonic acid, which is then oxidised with ethyl-*o*-toluidine to form an indamine, the latter being boiled and oxidised to the dye. The molecular structure of the dye-stuff is shown by the formula—

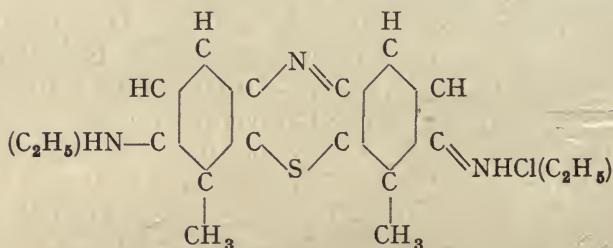

Thionine Blue G. is also manufactured by the methylene blue process, the same materials being used for the first operation producing dimethyl-*p*-phenylene-diaminethiosulphonic acid. This is then oxidised with methylethylaniline to form, first, an indamine, and then the dye, which has the formula—

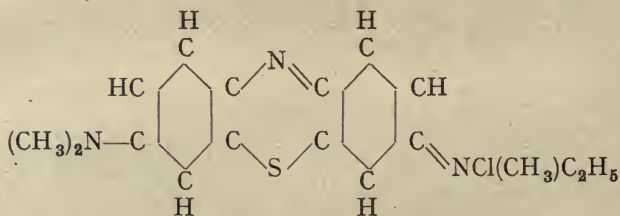

This dye-stuff is used for dyeing tannin-mordanted cotton, and also as a stain for bacteriological purposes.

Brilliant Alizarin Blue is a thiazine dye produced by the condensation of two sulphonic acids, namely, 1 : 2-naphthaquinone-6-sulphonic acid and dimethyl-*p*-phenylenediaminethiosulphonic acid. It is used for dyeing chrome mordanted wool, silk, and cotton, the colour imparted to the fabric being very fast. The formula for this dye-stuff is—

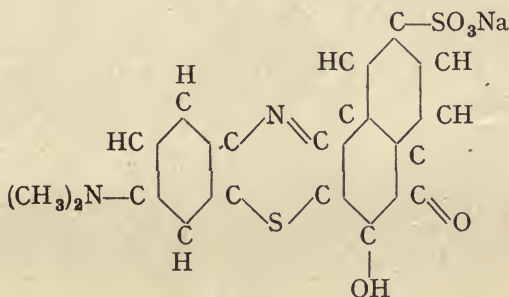

IV. THIAZOLE DYES.

These are dyes which are characterised by a five-membered ring, similar to the thiazine ring, but minus a carbon atom—

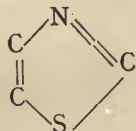

Primuline is a typical thiazole dye, and its manufacture and constitution have been fully described in Chapter III., where also a description will be found of its azo derivatives, the ingrain colours. If dehydrothiolumidine, which, it will be remembered, is formed

156 AZINE AND HETEROCYCLIC DYES

by the action of sulphur on *p*-toluidine, is methylated, a thiazole dye is formed, known as **Thioflavine T**. This is a greenish-yellow dye for tanned cotton or silk, and has the constitution—

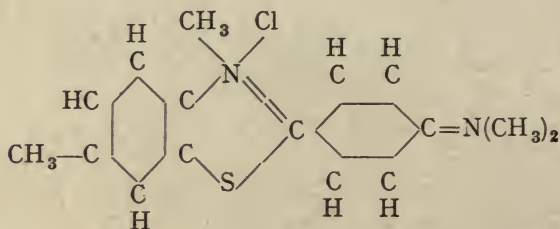

Other thiazole dyes have also been manufactured, most of which are derivatives of primuline.

CHAPTER VIII

SULPHIDE AND MISCELLANEOUS DYES

ALTHOUGH a large number of dye-stuffs—many of them of considerable commercial importance—is included in the Sulphide group, their exact constitution has not yet been definitely ascertained, chiefly owing to the fact that their proper analysis presents peculiar difficulties. Some of the dye-stuffs belonging to this series, however, resemble the thiazole and thiazine dyes, and probably contain their characteristic rings. But in spite of the uncertainty regarding their final constitution, their general character will readily be understood by a consideration of the substances from which they are made, and the comparatively simple method of their production. The sulphide dyes in general are soluble in sodium sulphide or hyposulphite, and in such solution they are used for dyeing cotton. The sodium sulphide has a reducing action on the dye-stuff, which is thus converted into a leuco-base, this leuco-base combining with the cotton fibre, on which it is then oxidised, and thus reconverted to the dye.

The general method for producing sulphide dyes consists in fusing a variety of parent substances with sulphur mixed with sodium sulphide (Na_2S), or sodium polysulphide (Na_2S_6). As many of the parent substances employed are nitro compounds, sulphur alone cannot be used for the fusion, owing to the danger of an explosion occurring. The vessel in which the fusion is

carried out is quite simple, and consists of a cast-iron, steam-jacketed, agitated pan, as shown in Fig. 15, which is connected to a reflux condenser.

If the temperature required for the fusion exceeds 200°C ., it is usual to employ a vessel which, instead of being heated by super-heated steam, is raised to the requisite temperature in an oil bath containing vaseline or some high-boiling-point oil, this method being preferable to exposing the vessel to the direct heat of a fire.

The first sulphide dye produced was a brown dye-stuff known as **Cachou de Laval**, which was manufactured by heating organic waste products of a cellulose character, such as sawdust, with sodium polysulphide, the temperature employed ranging between 250° and 300°C ., according to the darkness of the shade required. It is probable that the products thus obtained are of a phenolic nature existing in the quinonoid form.

Immedial Brown B. is another brown sulphide dye which imparts very fast yellowish-brown shades to cotton. It is manufactured by boiling 4-hydroxy-4-amino-diphenylamine with a solution of sodium hydroxide (NaOH) in water, the resulting product being then heated with sodium polysulphide to a temperature of 160°C .

Immedial Yellow GG. is a greenish-yellow dye for cotton, the colour imparted to the fabric being very fast. It is manufactured by fusing together sulphur, benzidine, and dehydrothiolumidine, the proportions used being one part of the latter substance to about four and a half parts of sulphur and one and a quarter parts of benzidine. The fusion is carried out at a temperature of 210°C ., and occupies one hour, after which the fused mass is placed in a digester, such as is

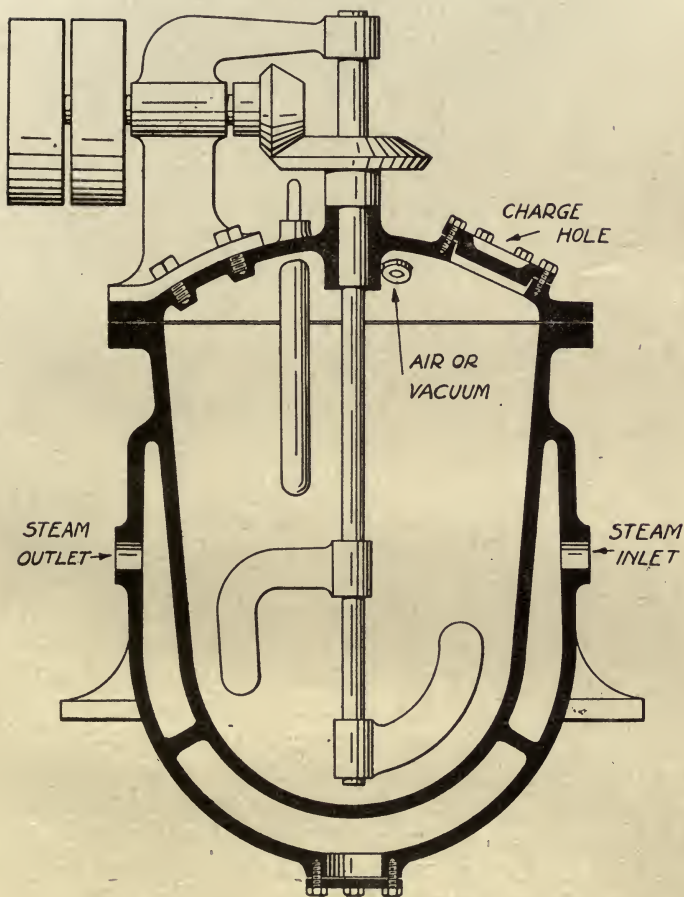
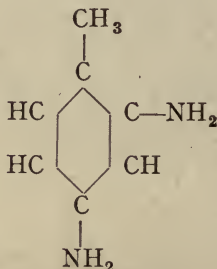

FIG. 15.
Sulphur Fusion Pan.

shown in Fig. 16, and treated with fused sodium sulphide at a temperature of 120° C. until the product becomes soluble. The dye-stuff is precipitated from its solution by means of mineral acid, and is a substance allied to the primuline dyes.

Immedial Orange C. is produced by fusing tolylene-2 : 4-diamine—



with sulphur in the proportions of two and a half parts by weight of the latter to one part of the former. As a product of the reaction resulting from the fusion hydrogen sulphide is evolved, and as soon as this ceases the fused product is formed into a hard mass by baking it at a temperature of 250° C. It is then mixed with a quantity of sodium sulphide equal to three times the weight of tolylene-2 : 4-diamine used, and heated to a temperature between 110° and 120° C. An aqueous solution of the mixture is then made, and the dye-stuff precipitated, as in the case of Immedial yellow, by means of mineral acid. The dye-stuff is used for producing orange-brown shades on cotton.

Italian Green is a sulphide dye obtained by gradually heating, to a temperature of 210° C., a solution of 27 lbs. of *p*-nitrophenol and 10 lbs. of copper sulphate in 4½ gallons of water, mixed with a solution of about 42 lbs. of sodium hydroxide and 38 lbs. of sulphur in

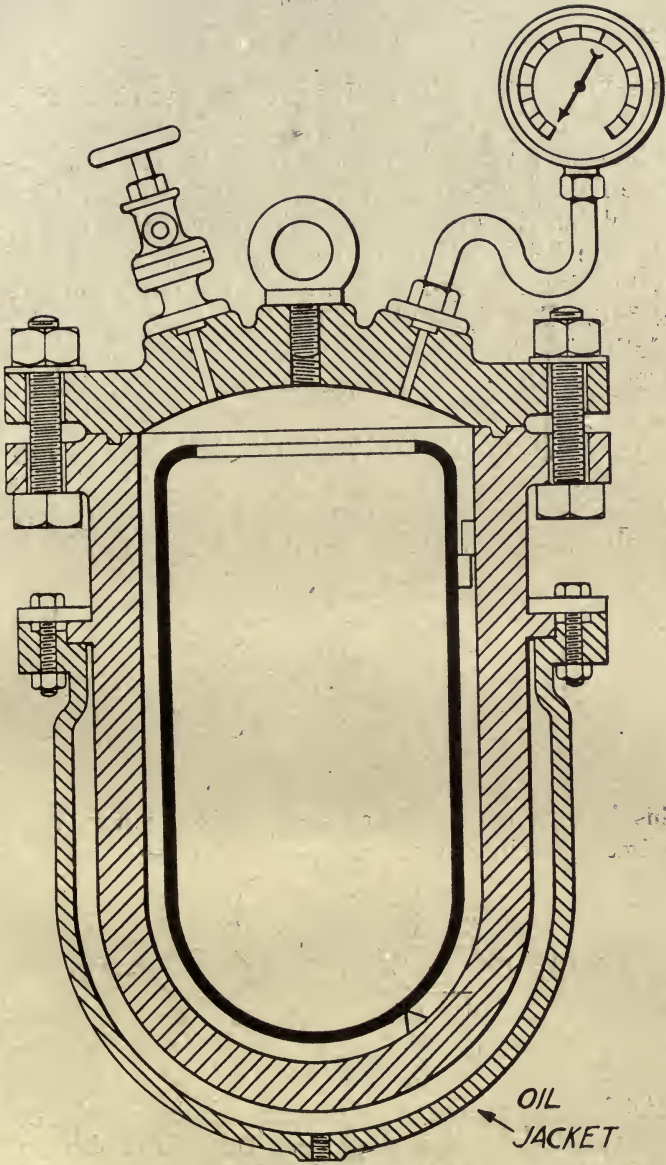
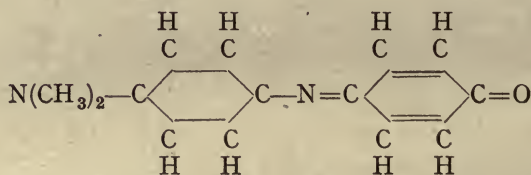

FIG. 16.
Digester or Autoclave.

3 $\frac{3}{4}$ gallons of hot water. The product thus obtained is used for dyeing cotton dull green shades.

Immedial Green is manufactured by dissolving 4-dimethylamino-4-hydroxydiphenylamine in a solution of sulphur in crystallised sodium sulphide, copper sulphate being added to the solution, which is then heated for twenty-four hours at a temperature of 120° C. The dye-stuff, which is obtained from its solution by precipitation with salt, is used for dyeing cotton bluish-green shades, which are fast to light and washing.

Immedial Pure Blue (Sky Blue) is a brilliant and very fast dye. It is manufactured by oxidising a mixture of reduced nitroso-dimethylaniline and an aqueous solution of phenol to what is called an indophenol—



This is then converted, by means of reduction, into 4-dimethylamino-4-hydroxydiphenylamine—

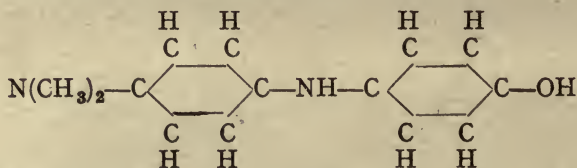

which is then added to a hot aqueous solution of sulphur and crystallised sodium sulphide. This mixture is then heated for twenty-four hours in a reflux apparatus at

a temperature of 110° C., after which the product is dissolved in water and the dye-stuff salted out.

Hydron Blue is a dark blue dye imparting a very fast and intense colour to the fabric. It is produced by reducing nitrosophenol—

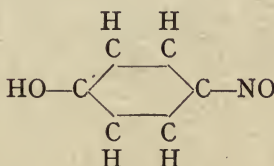

with carbazole—

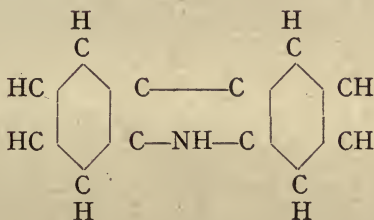

so as to form the indophenol—

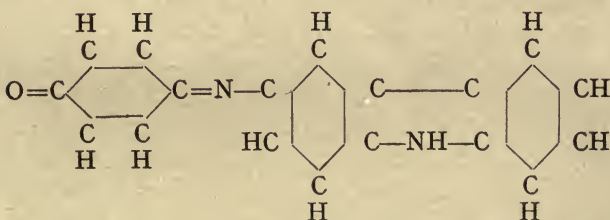

which is then heated with sodium sulphide and subsequently with sulphur.

Thiogen Violet V., another sulphide dye, is manufactured by heating together sulphur and phenosafraninone—

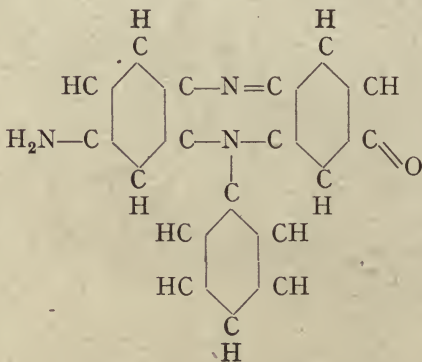

at a temperature of about 115° C., and then heating again at 200° C. with sodium sulphide. The product is then heated in a reflux apparatus at a temperature of 135° C. for about twenty hours with sodium polysulphide.

Vidal Black is an important sulphide dye, the discovery of which really marked the beginning of the development of this group of dye-stuffs. It is produced by gradually adding *p*-nitrophenol to melted sodium sulphide, in the proportion of one part of the former to four parts of the latter, and heating the mixture to a temperature of 130° C., whereby reduction of the *p*-nitrophenol is effected. The necessary quantity of sulphur, about 75 per cent. by weight of the *p*-nitrophenol used, is then added, and the temperature raised to between 150° and 175° C. During the reaction which follows hydrogen sulphide is given off, and the mixture becomes stiff, and as soon as stirring is no

longer possible the mass is dried at a temperature of 180° C. and purified by precipitation by mineral acid from a solution in sodium sulphide. The dye bath consists of a solution of the dye-stuff in sodium sulphide, and cotton immersed in this is dyed green, and subsequently chromed, the colour being thereby changed to a very fast black.

Anthraquinone Black is an intense dye produced by heating together one part of 1:4-dinitro-anthraquinone, five parts of sodium sulphide and one and a half parts of sulphur. The product forms a bluish-green solution in water, but is dissolved in sodium sulphide for dyeing purposes.

A large number of other sulphide dyes is known, but the foregoing will suffice to show their general nature.

ACRIDINE DYES

The acridine dyes are characterised by the acridine nucleus which contains one atom of nitrogen, carbon, and hydrogen arranged as shown in the formula for acridine—

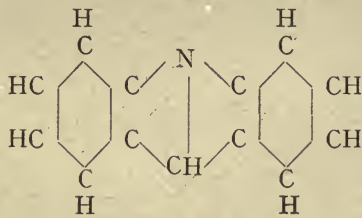

or $C_{13}H_9N$.

Acridine itself is present as an impurity in crude anthracene produced by the distillation of coal-tar, but the acridine dyes are synthesised from suitable component compounds, one of which is usually a meta-diamine. A general method for the manufacture of acridine dyes consists in condensing an aldehyde with a *m*-diamine, treating the product with mineral acid to eliminate ammonia, and then oxidising the hydro-acridine so produced to the dye itself. This method is used for the production of the yellow dye **Benzo-flavine**, which is used for dyeing cotton, and is a soluble orange powder, its solution in water showing a green fluorescence, which is characteristic of the acridine dyes. The first stage in its manufacture consists in condensing benzaldehyde—

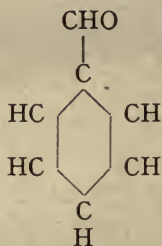

with *m*-toluenediamine—

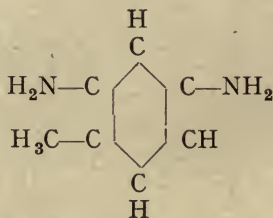

thus producing tetra-aminodimethylphenylacridine—

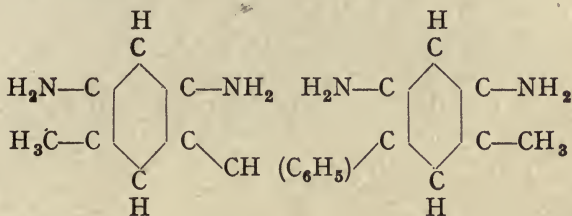

This is then treated with hydrochloric acid to remove ammonia, and is thus converted into the hydroacridine—

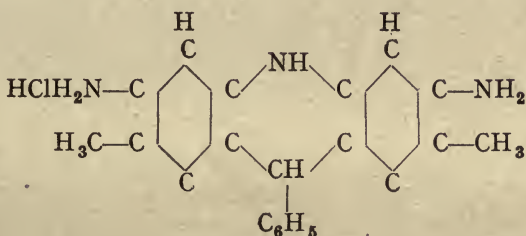

which is then oxidised, by treatment with an oxygen carrier such as ferric chloride (FeCl₃), thus producing the dye-stuff which is diaminodimethylphenylacridine hydrochloride—

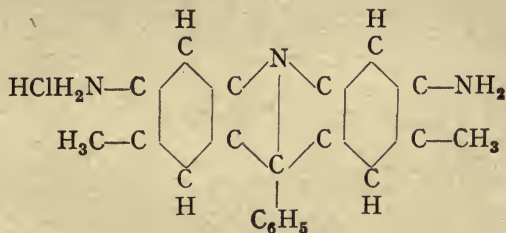

from the formula of which it will be seen that the hydrogen atom of the acridine nucleus has been replaced by a phenyl radical. If, instead of using benzaldehyde in the process just described, formaldehyde (H . CHO) is employed, another dye-stuff, **Acridine Yellow**, is produced, which is diaminodimethylacridine hydrochloride, having the formula—

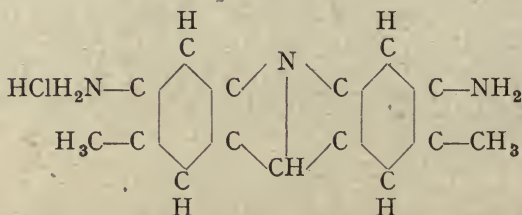

This is a soluble yellow powder used for dyeing yellow shades on tanned cotton, whilst it also dyes silk greenish-yellow, having a green fluorescence.

Acridine Orange is produced in a similar manner, by condensing dimethyl-*m*-phenylenediamine with formaldehyde. It is a soluble orange powder which produces fast shades on cotton mordanted with tannin. The dye-stuff is a zinc chloride double salt having the formula—

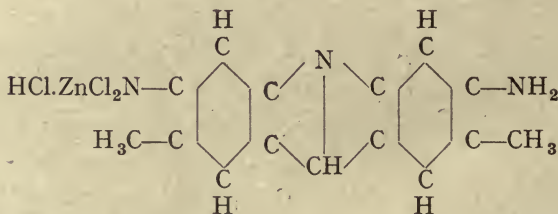

Rheonine is an acridine dye obtained by condensing tetramethyldiaminobenzophenone—

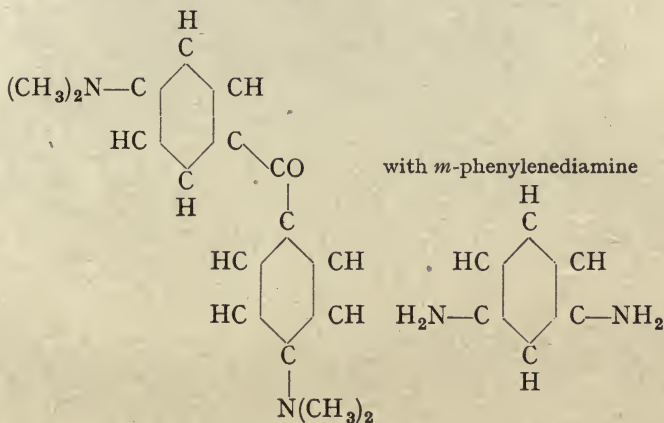

at a temperature of 200° C. in the presence of zinc chloride. The dye is a brown powder which dyes tanned cotton or leather brownish-yellow shades. It is soluble in water, the solution showing a characteristic green fluorescence, the constitution of the dye-stuff being represented by the formula—

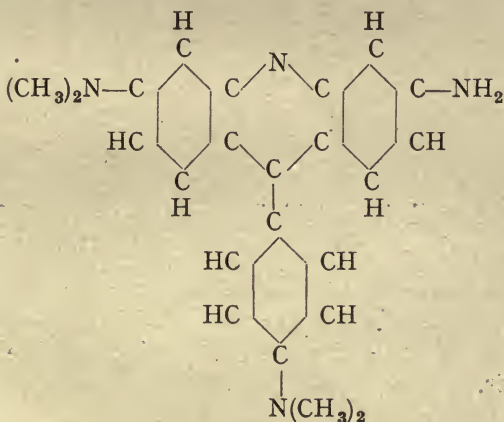

Flaveosine is obtained by condensing *m*-acetamidodimethylaniline—

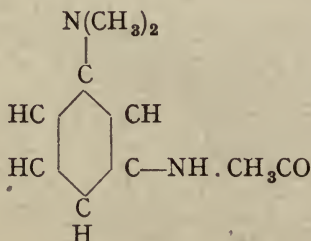

with phthalic anhydride—

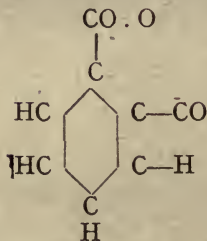

The dye-stuff forms shining golden yellow flakes, and dyes tanned cotton and wool fast reddish-yellow shades, and silk a beautiful golden yellow.

▮ **Chrysaniline** is a leather dye, and is a by-product in the manufacture of magenta. It is a soluble orange-powder.

Phosphine is also a leather dye, and has the formula—

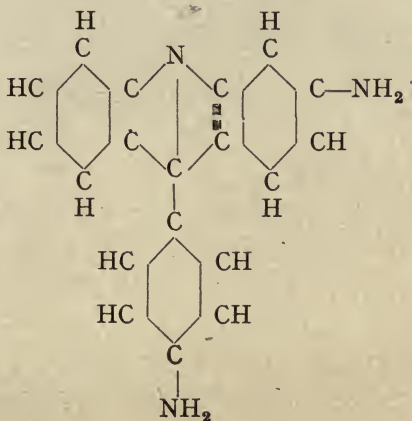

It is a by-product in the manufacture of rosaniline, from which magenta is derived. Other phosphines may also be obtained by alkylating acridine yellow and benzoflavine. A number of other acridine dyes have been prepared, amongst which may be mentioned the Corioflavines, which are red or reddish-brown leather dyes.

ANILINE BLACK.

This dye-stuff is extremely important for cotton dyeing, but is seldom produced in substance, being almost always produced on the fabric to be dyed by a process of oxidation. Although produced simply by the oxidation of an aniline salt, its constitution has not been finally determined, although it is now recognised that it is a complex product having a high molecular weight. If the oxidation is not carried to its final

extent, the black produced is liable to turn green after a time, owing to the action of sulphurous acid, which is contained in the atmosphere. In producing the best blacks, however, care is always taken to ensure that the oxidation is complete, in addition to which the fabric is often "woaded," or grounded with indigo in order to improve the appearance and durability of the black subsequently produced on the cloth. The oxidising agents employed for developing this dye-stuff are usually bichromate of potash or soda, potassium ferricyanide, and sodium chlorate. A catalyst, such as copper sulphate (bluestone) is often used to promote the necessary chemical action, and is, in fact, necessary when sodium chlorate is employed as the oxidising agent. When the dye is developed in the dye-bath, the fabric, after being washed, soaped, and dried, is treated in a hot bichromate bath in order to ensure the complete oxidation of the aniline; but it is more usual and advantageous to immerse the fabric in the dye-bath, and then, after drying, develop the black by means of a process known as "ageing," which is described in Chapter IX. The development of the dye by the ageing process occupies from six to eight hours, after which the fabric is treated for about a quarter of an hour in a hot bichromate bath and subsequently washed, soaped, and dried. Within recent years a very important new process for producing aniline black has been developed. This consists in oxidising the aniline salt by atmospheric air in the presence of a catalytic agent composed of paraphenylenediamine and copper sulphate.

The inventor of this process, A. G. Green, has shown that aniline black consists of several quinonoid substances, the most important of which are Emeraldine and Nigraniline, but it seems probable that these

substances are still further oxidised with a further quantity of aniline so as to produce a final azonium compound having the formula—

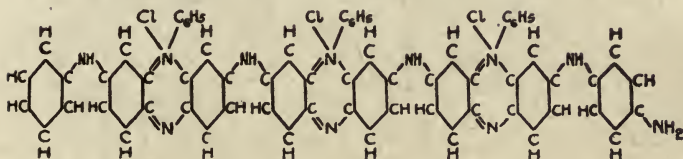

NITRO DYES.

These are aromatic nitro compounds of comparatively simple constitution. They are mostly acid wool dyes, and the processes for their manufacture are all very similar.

Picric Acid,* or trinitrophenol $C_6H_2OH(NO_2)_3$, is one of the oldest artificial dyes, and is used for dyeing wool, silk, and leather. It is the final product of the nitration of phenol.

Martius Yellow, an acid wool dye, is dinitro-*a*-naphthol, which, if sulphonated, produces two sulphonic acids which are dye-stuffs, and are known as **Naphthol Yellow S.** and **Naphthol Yellow RS.**

Aurantia, another acid wool dye, is the final product of the nitration of diphenylamine, namely, hexanitrodiphenylamine.

* The manufacture of Picric Acid is fully described in the authors' "Manual on Explosives."

QUINOLINE DYES.

These are used mainly as sensitisers for silver bromide photographic plates and films, as very few of them are suitable for textile work. As their name implies, they are derivatives of quinoline, a substance which consists of a benzene and a pyridine ring united as shown in the formula—

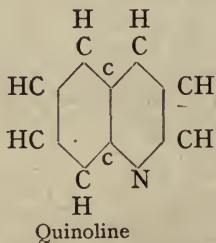

or C_9H_7N .

whilst some of them, known as the Isoquinolines, are derived from an isomeric form of quinoline in which the nitrogen atom occupies the β position, thus—

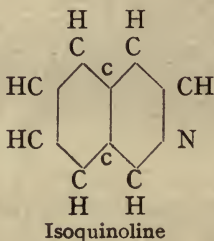

Both quinoline and isoquinoline are contained in coal-tar, from which they can be extracted by fractional distillation; or they can be synthesised from aniline and glycerol ($C_3H_8O_3$).

Cyanine is a blue quinoline dye used as a panchromatic sensitiser. It is prepared by reacting on a mixture of quinoline and lepidine with amyl iodide, its technical name being lepidinquinolineamylcyaniniodide.

Ethylcyanin is a similar dye, which is prepared in the same manner, ethyl bromide being used instead of amyl iodide.

Ethyl Red is an isocyanine dye used as a red sensitiser, and prepared by the action of ethyl iodide on a mixture of quinoline and quinaldine, or *a*-methylquinoline. A number of other quinoline dyes are prepared for photographic purposes, but those already given are sufficiently representative. As a dye suitable for textile work we may mention the sulphonic acid of **Quinoline Yellow**, which latter is manufactured from quinaldine and phthalic anhydride, the sulphonic derivative being used for dyeing wool. Many other dye-stuffs are, of course, known belonging to the various groups, whilst scarcely a week passes without fresh patent applications being made for new dyes and new methods for their manufacture.

CHAPTER IX

THE APPLICATIONS OF ARTIFICIAL DYE-STUFFS

I.—HOW FABRICS ARE DYED

BEFORE proceeding to describe the actual mechanical means by which fabrics are dyed, it is necessary that the distinctions between the natures of the various classes of dye-stuffs should be made perfectly clear. From the preceding chapters it is evident that some dye-stuffs of an acid nature combine directly with fabrics to form fast colours ; others, such as alizarin and a number of its derivatives, only give colours in combination with substances known as mordants ; whilst with a third group, of which indigo is the chief example, it is simply necessary to dip a fabric in a solution of the dye to impart colour thereto, either immediately or after oxidation in the atmosphere, or by other means. The latter is the oldest method of dyeing at present in use, having received much wider application of late years owing to the introduction of artificial indigo, and a number of other vat dyes.

Dye-stuffs which are taken directly out of a solution by a fabric are usually termed "substantive" dye-stuffs, whilst those which are precipitated chemically as insoluble substances during a series of successive operations are termed "adjective" dye-stuffs.

Further, different textile fabrics require different treatments ; and a great division has to be made between fabrics of animal origin, such as wool and silk,

and those of a vegetable nature, such as cotton. For example, suppose three pieces of material, of wool, silk, and cotton respectively, are dipped in a solution of picric acid. All will be dyed a bright yellow; but if they are subsequently washed in a solution of soap and water the wool and silk will be found to have retained the colour, whilst the latter will be washed out of the cotton. The reason for this is not far to seek; animal fibres contain among other constituents substances of the nature of amino-acids, with which acid dyes such as picric acid and basic aniline dyes form insoluble compounds; whilst the cellulose of which cotton is mainly composed is practically a neutral substance, and only in comparatively rare instances does it combine with colouring matters.

In order, therefore, to dye cotton, a mordant must be introduced into the fibre to form an insoluble compound with the dye-stuff, this compound, be it noted, forming on the fibres of a piece of material, instead of being a chemical combination with them, as in the case of fabrics of animal origin. From an earlier chapter, however, it will be seen that a number of direct cotton dyes have recently been introduced, these being also useful in dyeing what are known as union fabrics—that is, mixtures of cotton and wool.

Mordant dyes themselves fall into two groups, those which give one colour whatever the mordant used being known as “monogenetic,” whilst those such as alizarin, which give varying shades with different mordants, are known as “polygenetic.”

Before proceeding further, a few remarks are necessary in connection with water, which plays such an important part in the dyeing of fabrics. As is well known, most natural waters contain a certain proportion of alkaline constituents, and in order that the

latter may not have an injurious effect upon the colours they must be neutralised before use by means of an acid, sulphuric or acetic being those generally employed for the purpose, the latter preferably, since a small accidental excess does no harm. When acid colours are to be used, however, this preliminary neutralisation is unnecessary, since enough acid is added during the process to effect the desired end.

Waters containing substances of the nature of iron and lime also generally require special treatment before use, as iron will act as a mordant, usually tending to dull otherwise brilliant colours. Lime also will in certain cases act as a mordant unless eliminated, whilst all hard waters should be softened before using with direct cotton dyes and sulphur colours.

With these few remarks on the physical natures of the substances employed it is now possible to describe the actual dyeing operations. Textile fibres may be dyed at any stage of their manufacture into fabrics, either as loose fibres, as hanks of yarn, when wound into cops or on to bobbins, or as finished cloth, the latter, known as piece-dyeing, being much more frequently resorted to than dyeing the material at earlier stages in its manufacture. At whichever stage the fibres are dyed, however, they must be subjected to a preliminary treatment to free them from impurities, particularly from fatty substances, which not only occur naturally in wool, but are added for certain purposes during the operations of spinning and weaving. In order that no risk may be run of spoiling delicate shades, bleaching of the fabrics is frequently necessary before dyeing, and fibres should always be thoroughly wetted before immersion in the dye-bath.

Dyes, after dissolving in water, should be filtered before use.

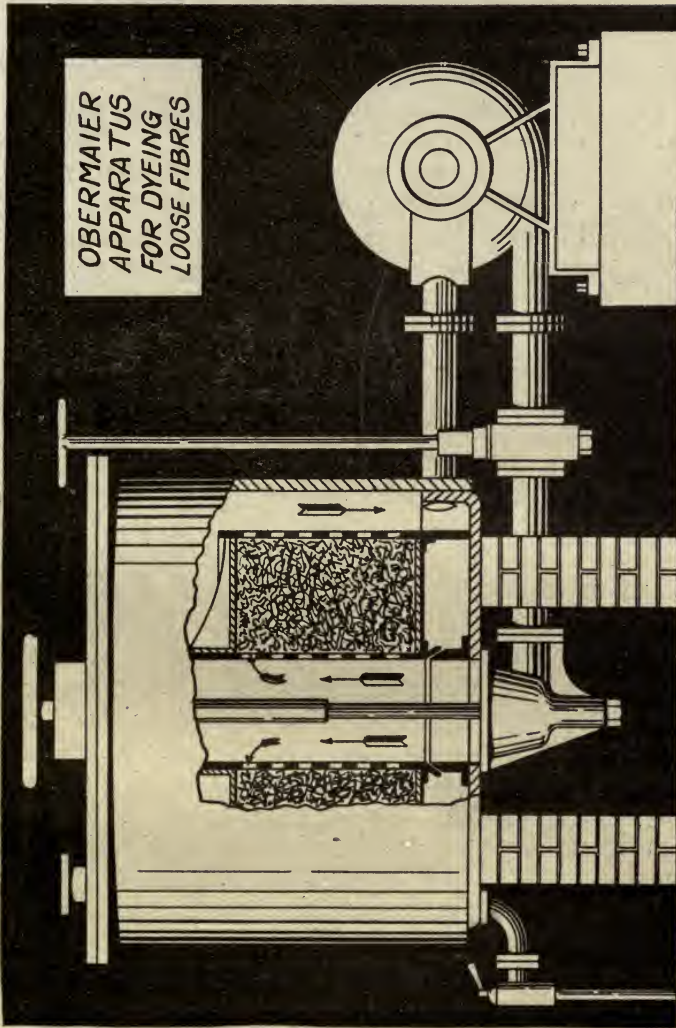

To dye fibres thoroughly constant movement is necessary, and where it is not possible to keep them moving through the liquid means are employed to circulate the liquid constantly through the fibres, these operations being usually carried out in heated vats, as will appear hereafter.

Fig. 17 illustrates what is known as the Obermaier type of machine for dyeing loose fibres such as cotton or wool. The material to be dyed is placed in an annular drum having perforations on its inner and outer walls. This drum is fitted inside the dye-tank, from which it can be lifted by means of a crane for the purpose of charging and discharging. Pipes having a control valve connect the tank with a centrifugal pump, by which the liquor is circulated in the direction of the arrows. A drain cock is provided whereby the liquor may be run off when spent.

Fig. 18 shows a vat for dyeing yarn in the hank—an operation usually performed by hand. The vat is of wood, is of rectangular form, and provided with a perforated steam coil for heating, the hanks being kept out of contact with this coil by a false bottom. The hanks are suspended on square wooden bars resting on the upper edges of the vat, and workmen at either side of the vat constantly turn the hanks so that the exposed portions become submerged, this being generally accomplished by inserting a thin rod in the loop of the hanks beneath the square bar and raising it outwardly.

Owing to the slowness of this method a number of machines have been devised for performing the same functions automatically, and in Fig. 19 a hank-dyeing machine is illustrated. This machine comprises two sets of rods arranged concentrically in discs mounted on a central rotating shaft. Each hank is disposed as

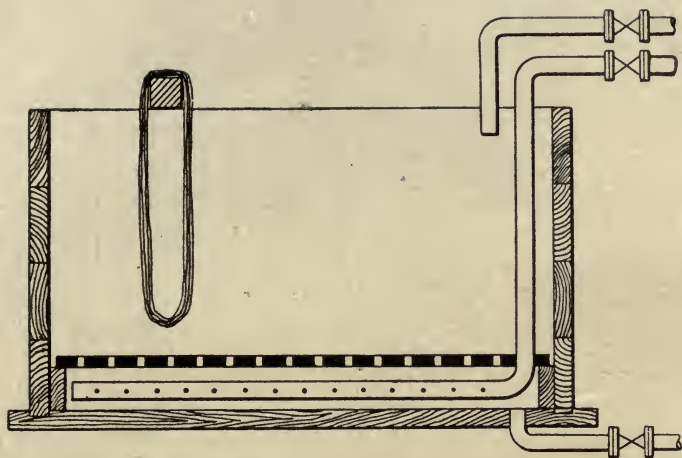

FIG. 18.—Vat for dyeing Yarn in Hanks by Hand.

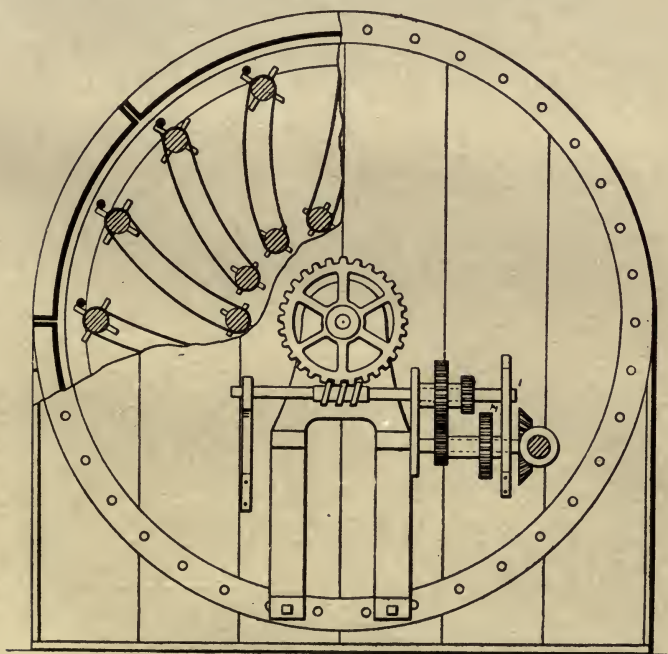

FIG. 19.—Hank-Dyeing Machine.

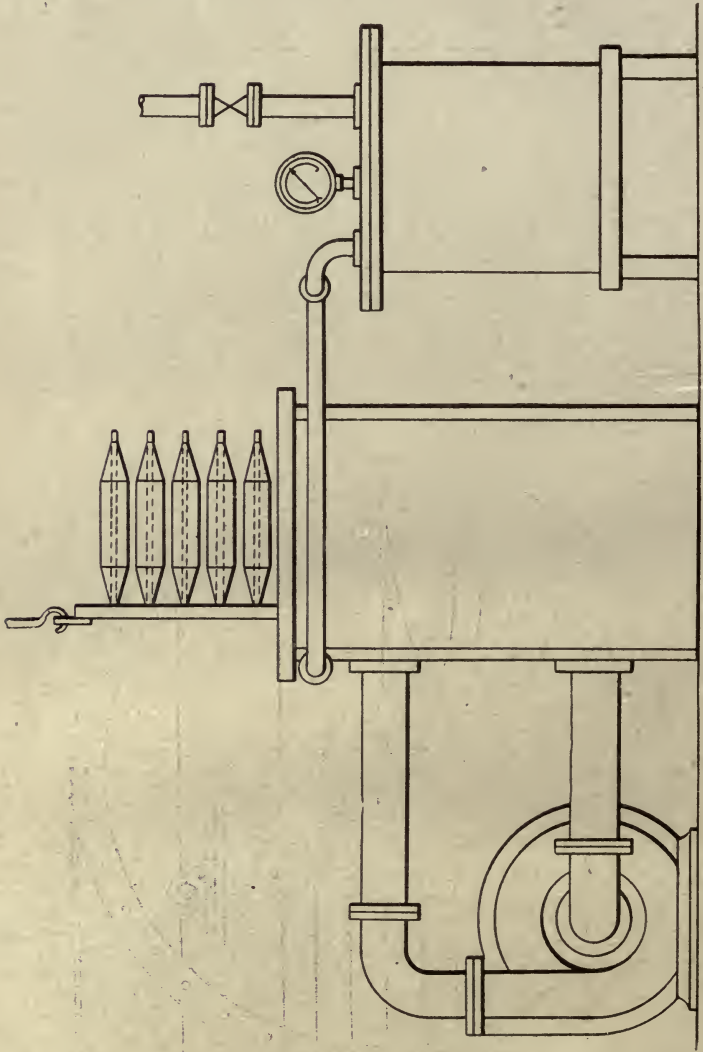

FIG. 20.—Cop-Dyeing Machine.

shown over an inner and an outer rod. These rods themselves receive a rotary motion, and, as the whole series moves slowly round within the casing, the hanks are alternately dipped in the liquor and lifted out to drain.

Fig. 20 illustrates, by way of example, a machine for dyeing cops, bobbins, and the like. Each cop or bobbin is on a hollow perforated skewer, a number being arranged in cylindrical fashion as shown, and immersed in the vat through which the dye liquor is forced by means of a pump. The perforations in the skewers on which the cops or bobbins are mounted allow the dye liquor to penetrate to every part of the threads.

Turning now to the dyeing of piece goods. Fig. 21 shows a vat for dyeing heavy pile fabrics. The pieces are stitched together to form an endless band, which is fed into and drawn out of the vat by the winch A, driven from some suitable source of power. The vat is heated by steam passing through the jacket B.

A machine very largely used in the dyeing of piece-goods is the Jigger, Fig. 22, which is principally used for cotton cloth. The jigger comprises two draw-rollers, 1 and 2 placed above the vat 3, the cloth in journeying from the one to the other passing over the guide rollers, 4, 5, 6, 7, and 8, of which the two latter are submerged. Each of the draw-rollers 1 and 2 is provided with a tension brake, 9, and each may be driven separately, in opposite directions, from the driving shaft 10. The draw-rollers are driven alternately until the one is full and the other empty, when the brakes are altered and the motion reversed. This is continued until the cloth is dyed the desired shade, after which it is run off on to the batch roller 11. Steam is supplied through the perforated pipe 12.

The pieces of machinery above described are of general application, and may be used for different

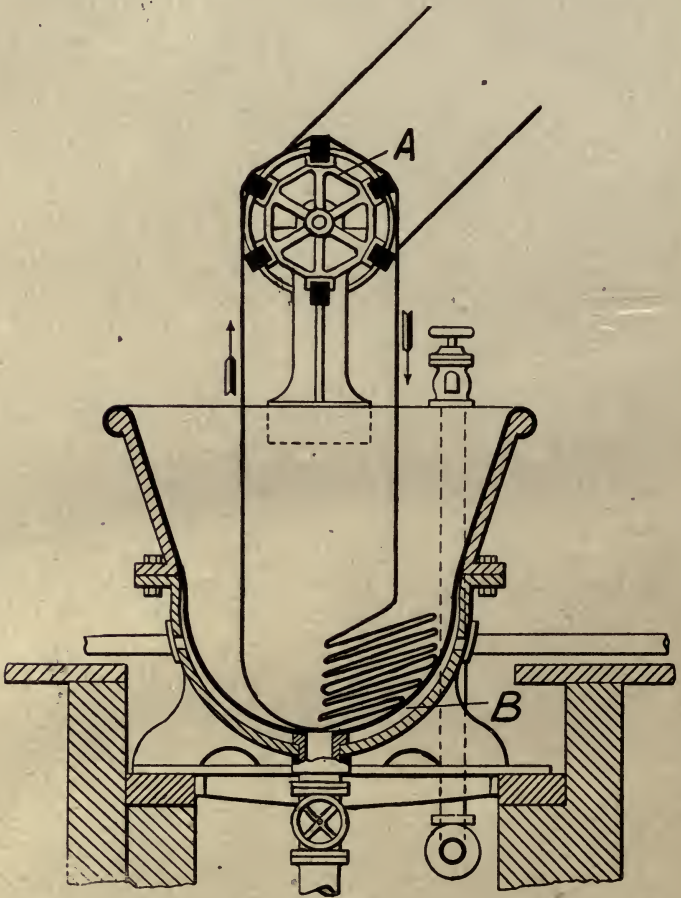

FIG. 21.
Double-walled Copper Dye-vat for Pile Fabrics.

classes of dyes, but in some cases it has been necessary to design special machines for certain colours, and some

of these will be described later in connection with the dye-stuffs for which they are used.

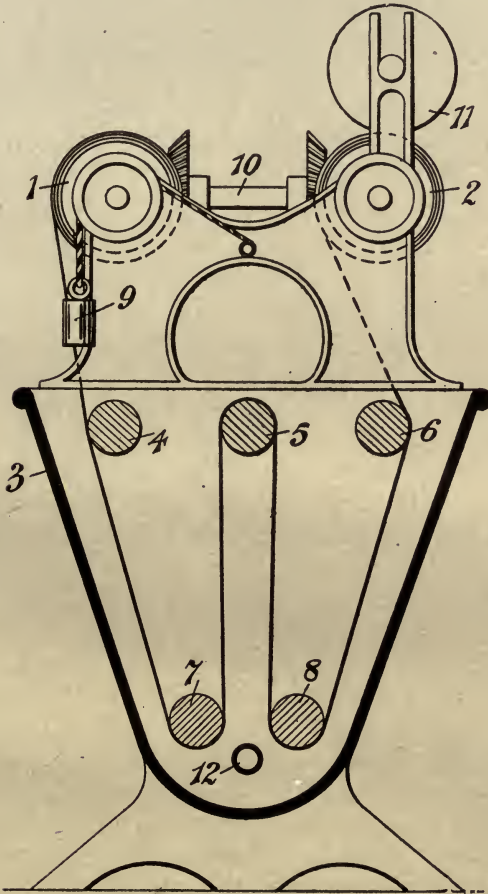

FIG 22.
Jigger (Lower Part in Section).

All the dye-stuffs described in the preceding chapters are, for the purposes of dyeing, grouped into eight

classes, each of which will be dealt with separately. The groups are not altogether strictly defined, as some dye-stuffs may be classed in more than one, according to which of their properties are taken into account. For example, some of the direct cotton dyes fall under the heading of Acid Dye-stuffs. The latter constitute the first group to which it is proposed to direct the attention of the reader for the purpose of outlining, very briefly, the operations necessary to the production of colours on textile materials.

The **Acid dye-stuffs** are either nitro-compounds or sulphonic acids, as will be seen from earlier chapters. They are not generally sold commercially in such forms, however, but as sodium or calcium salts. They are used largely in dyeing wool and silk, but, except in the case of the direct cotton dyes, they produce only fugitive stains on cotton.

Wool is dyed at boiling temperature, and the colouring acid is liberated from its commercial salt by the addition of sulphuric acid. Recent research has led to the sulphuric acid being added in considerably larger quantities than is necessary for such liberation, owing to the fact that it produces from the wool lanuginic acid, the substance which really combines with the dye-stuff to produce the colour on the fibre.

For the purpose of example it may be stated that to dye 220 lbs. of wool a bath of 1,000-2,000 gallons' capacity should be employed, containing about 8 lbs. of concentrated sulphuric acid, 16-20 lbs. of Glauber's salt crystals, and the necessary amount of dye-stuff. The dyeing operation is commenced at about 70° C., and heat applied till boiling-point is reached, the wool being left in the boiling bath for about an hour.

The Glauber's salt is added on account of the fact that it has a slight solvent action on the dye taken

up by the fibre, and is therefore useful in removing it from places where an excess of colour has been deposited.

The above is, of course, not applicable in the case of every acid dye-stuff, and certain modifications are made to meet special needs ; for instance, the addition of stannic chloride increases the brilliancy of a shade.

In dyeing silk with acid dye-stuffs, a temperature slightly below boiling is maintained throughout the dyeing operation, the silk being afterwards washed in water and brightened with sulphuric, acetic, or tartaric acid, which is absorbed by the silk, increasing its lustre and imparting to it the property of "rustling" when folded and pressed together.

The **Basic dyes** are the salts of colourless bases which contain chromophoric groups. They will produce colours directly on animal fibres, but require mordants for cotton. In their commercial form they are usually sold as hydrochlorides and occasionally in the form of acetates, oxalates, and sulphates.

Wool is dyed from a neutral, or slightly acid, or alkaline bath, which is started cold and gradually raised to the boil, dyeing being continued until the bath is exhausted. About one part by weight of the dye-stuff to 200 parts by weight of wool is sufficient, and the dye should be filtered before adding to the bath.

The basic dyes find a very wide application in the dyeing of silk, the treatment being similar to that of wool above described, except that the temperature is maintained slightly below boiling-point, and boiled-off liquor from the treatment of raw silk, or neutral soap solution, is added to the bath. After washing, the silk is brightened as already described.

MORDANT DYES

As already explained, the mordant dyes cannot be fixed directly on the fibre, but only through the medium of another substance previously deposited on the fibre, with which the dye-stuff forms an insoluble compound called a colour-lake.

Various mordants are employed according to the nature of the dye-stuff; for instance, metallic hydroxides may be deposited on textile fibres, and, as in the case of alizarin already noted, are subsequently dissociated by the dye to form a fast colour. Cotton, however, does not readily take up these metal salts, far less decompose them, and therefore in dyeing cotton with mordant dyes it is necessary to employ an acid substance to act as a fixing agent.

An important acid mordant is tannic acid, a member of the group of substances known as the tannins, which not only possess the property of combining with the metal salts used as mordants, but also that of combining with basic dyes, and it is by the agency of such substances as the tannins that basic dyes can be used for cotton goods.

In dyeing with tannic acid as a fixing agent, the bath may include up to 8 per cent. of that substance on the weight of cotton treated, according to the amount of colour to be fixed. If the final shade of the material is to be a pale one, it remains for a period of one half to an hour in the dye-bath. For darker shades, however, a boiling temperature is maintained, and the material is subsequently treated in a cooling bath for about twelve hours. It then enters a bath containing tartar-emetic, a basic soluble antimony salt, in the proportions of $\frac{1}{4}$ per cent. to 4 per cent. on the weight of cotton, the latter remaining in the bath for about a

quarter of an hour. An insoluble antimony tannin compound is thereby produced, but the material must be thoroughly washed in a further tannin bath to remove any excess of the antimony salt.

Another important acid mordant is Turkey-red Oil, which is produced by the action of concentrated sulphuric acid on such oils as olive oil, cotton-seed oil, and castor oil, and, besides being soluble in water, retains many of the properties of the oils from which it is produced. As its name implies, it is employed very largely in the production of Turkey-red on cotton, the following being typical of the processes employed for attaining this end.

The cotton, after bleaching, is steeped in a 10 or 15 per cent. solution of Turkey-red oil in water. The excess of oil is squeezed out, and the goods aged or steamed at 5 lbs. pressure to render the oil insoluble and fix it on the fibre. The next stage consists in mordanting the goods in a tepid solution of aluminium acetate (red liquor). The mordanted cotton is then worked in a cold bath of alizarin suspended in water containing lime, calcium being essential to the formation of the colour-lake, and the bath is slowly heated to 70° C., and maintained at this temperature until all the dye is deposited.

The cotton is by this time a dull red in colour, and to develop a brilliant shade it is steamed at 15 lbs. pressure for one hour, being sometimes oiled a second time before this steaming. It is then washed thoroughly with soap, two or three times, and it should be carefully noted that throughout the process all traces of iron must be eliminated from the various baths.

By varying the mordant and using salts of iron, tin, chromium, etc., other shades can be produced.

In dyeing wool and silk with alizarin similar mordants

are employed to those employed for cotton, but the Turkey-red oil is unnecessary. The bath may be made up, for example, in the proportions of 10 parts by weight of alizarin paste, 2 parts of calcium acetate, 1 part of soap, and $\frac{1}{2}$ part of tannic acid. The wool, after mordanting, is introduced to the bath made up as above, while cold, heat being subsequently applied, and the bath maintained at boiling temperature for an hour and a half. For light shades the wool may be mordanted and dyed simultaneously from the same bath.

Nearly all insoluble metal hydroxides are capable of acting as mordants, and forming colour-lakes with various dyes, a very important and widely used mordant for wool being the bichromate of potassium or sodium.

The **Vat Dyes**, of which indigo is the best known example, are substances insoluble in water, which must be treated with a reducing agent and dissolved in an alkaline solution to form a dye liquor readily taken up by fibres, on which the actual colour is produced by oxidation in air after immersion in the liquid.

A number of reducing agents is in common use, some of which serve in dyeing both wool and cotton. One method of dyeing indigo on cotton is by means of the hydrosulphite vat, which may be made up as follows. The capacity of the dye vat is preferably 220 gallons, and a stock liquor is introduced therein which has been prepared by heating to 60° C., 10 parts by weight of 30 per cent. indigo paste, 20 parts of water, 2 parts of sodium hydrosulphite, and 6 parts of caustic soda solution.

A small quantity of hydrosulphite is also added to the liquor after introduction to the vat to remove any superfluous oxygen, and the cotton is dyed cold.

For wool the proportions of indigo paste and water should be about equal, and the amount of caustic soda solution about one-third that required in dyeing cotton, whilst the wool must be dyed at a temperature of about 50° C.

Cotton is also dyed with indigo in the copperas vat. For this vat a stock liquor is first prepared consisting of 20 parts by weight of 20 per cent. indigo paste, 25 parts of quicklime, and 20 parts of green copperas (ferrous sulphate). This is stirred intermittently for about six hours, during which time the lime reacts with the ferrous sulphate to form ferrous hydroxide, which in turn reacts with the indigo to form ferric hydroxide; thereby acting as a reducing agent for the indigo by depriving it of its oxygen. The liquor is introduced into the dye vat with about three times its volume of water, and dyeing commenced. The large amount of sediment produced, however, renders this process unsuitable for continuous dyeing, and as an alternative the zinc-lime vat may be employed. In this case the stock solution consists of 10 parts by weight of 20 per cent. indigo paste, $1\frac{1}{4}$ parts of zinc dust, and 20 parts of water. Five parts of quicklime slaked to a paste are subsequently added, and also about 25 parts of hot water, the whole being maintained at a temperature of between 50° and 60° C. for about four hours. The reduction in this case is effected by the nascent hydrogen produced by the reaction between the zinc and lime. In preparing the vat for dyeing, further small proportions of zinc dust and lime, about one part of the former to 4 parts of the latter, are introduced, and, after stirring and settling, dyeing may commence.

It should be understood that the proportions given above are varied by different dyers, whilst other

reducing agents may be employed, of which space will not permit a description.

In Fig. 23 is shown a machine specially designed for indigo dyeing, in which the operations of steeping and oxidising may be carried out in a continuous manner. In the vat A is disposed a series of rollers B, over which cloth is run, the lower set of rollers being completely submerged in the liquor. The cloth then passes through squeezing rollers C, and on to an endless travelling band D, on which it is piled loosely to oxidise the indigo white deposited thereon in the vat A. The dye vat is provided with an agitator, E.

Dipping vats are also employed in indigo dyeing, the cloth being disposed in frames which are lowered into the vat and subsequently removed with the cloth still in position for the oxidation part of the process.

A number of other vat dyes is described in chapters IV. and V., and may be applied to fabrics in much the same way as indigo, namely, by reduction in alkaline solution, steeping the fabric therein, and oxidising in air.

It must also be mentioned that indigo is used largely as a backing for compound shades, such as browns, olives, and blacks, good quality cloths being dyed first with indigo before receiving these colours.

The **Direct Dyes**, which have simplified the dyeing of cotton to a very great extent in recent years, consist mainly of three groups of chemical compounds, a number of examples of which will be found in earlier chapters, the first being the congo-red group, the second the primuline group, and the third the distilbene azo dyes.

Several processes are in use for dyeing with these substances, of which the following will serve as examples.

According to one process, cotton is treated for not

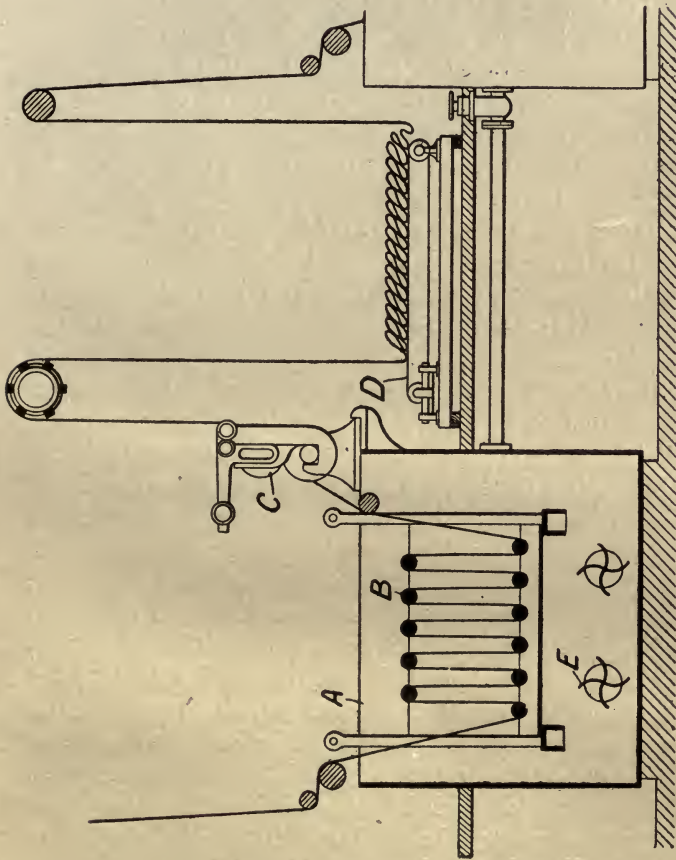

FIG. 23.
Indigo Dyeing Machine.

more than one and a half hours at boiling temperature in a neutral or alkaline bath, the weight of the solution in which is anything from ten to thirty times that of the cotton. To aid in the exhaustion of the bath a substance known as an assistant is added in small proportions. For this purpose Glauber's salts, common salt, soda, borax, sodium phosphate, or soap, may be employed. These substances do not enter into combination, but merely aid in the deposition of the dye on the fibres.

Cotton can also be dyed cold, but in this case the dye-stuff is mixed with an equal weight of caustic soda solution, and the whole dissolved in boiling water. When cold the cotton is introduced and dyed with the addition of a little soap.

The colours obtained with these direct cotton dyes are frequently improved by after-treatment with such substances as copper sulphate and chromium salts.

In dyeing fibres with the **Sulphur Colours**, no vat made of copper or its alloys must be employed, as these dye-stuffs combine readily with that metal, which would therefore produce deleterious effects in the colours. The sulphur colours are insoluble in water, and are therefore dyed from a sodium sulphide solution. In preparing the dye bath, the dye-stuff with three or four times its weight of sodium sulphide crystals, and some soda ash in the proportion of about 5 per cent. on the weight of cotton treated, are dissolved in hot water, and the solution added to the bath with water in an amount equal to about thirty times the weight of cotton. The bath also contains common salt, the quantity of which varies according to the depth of shade desired, as much as 60 per cent. on the weight of cotton being employed for dark shades. For these dark shades a boiling temperature is employed, and

dyeing takes several hours, whilst for lighter shades a much lower temperature may be employed, and dyeing takes a much shorter time.

The sulphur colours are not generally employed for wool, as the alkaline solution has a deleterious effect on animal fibres unless the latter are subjected to special treatment first. Further, there is a tendency for sulphuric acid to be formed in fabrics dyed with the sulphur colours, and to counteract the effects of this substance the cotton is frequently subjected to an after-treatment with a slightly alkaline substance, such as soap or sodium acetate.

The **Ingrain Colours** are produced directly from their constituents on the fibre. The chief dye-stuff of this group is Aniline Black, whilst other important members are azo bodies, such as para-reds, and browns, and some of the mineral colours. They are chiefly cotton dyes.

Aniline black is produced on the fibre by the oxidation of an aniline salt to a completely insoluble compound, and the production of the colour is carried out largely at the present day by what is known as the ageing process. The process is characterised in that the colour is not produced in the dye-bath, but the oxidation is effected after the fabric is removed therefrom.

According to one method the cotton, after boiling with soda, is treated for about half an hour in a liquor made up with about 300 parts of an aniline salt solution, 50 parts of copper sulphate solution, 40 parts of sodium chlorate solution, 12 parts of ammonium chloride solution, and 20 parts of aluminium acetate solution. The cotton is then wrung or otherwise treated to remove superfluous liquor, stretched, dried, and aged. The two latter operations are preferably carried out in the rapid ager shown in Fig. 24. The

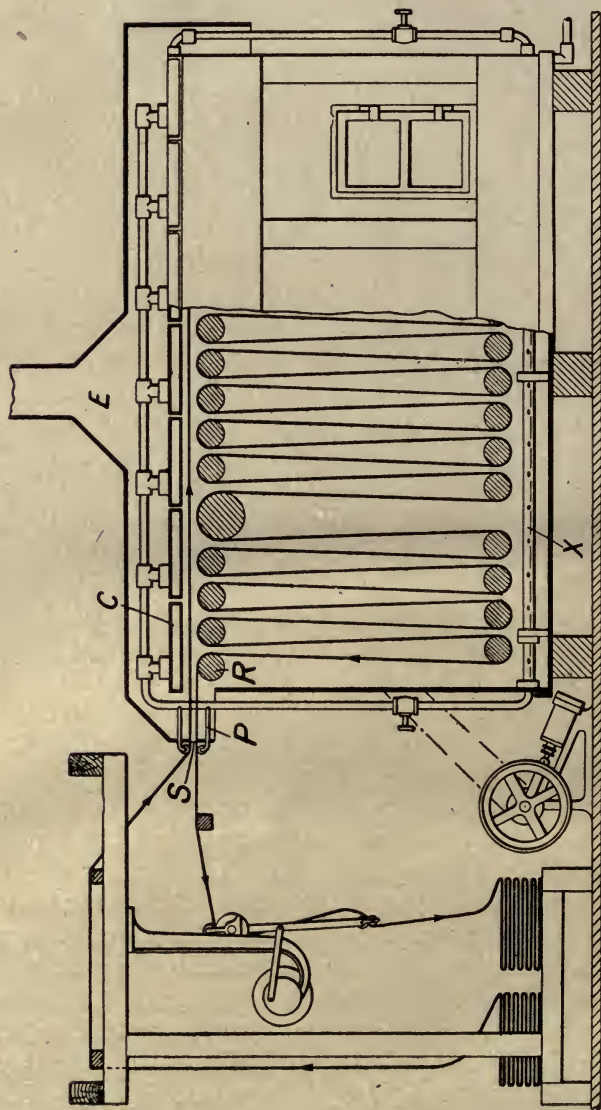

FIG. 24.
Rapid Ager for Aniline Black.

cotton passes continuously over the copper rollers R, disposed in chambers heated by steam passing through coils C, and issuing from a perforated pipe X. A powerful fan fitted at the top, E, draws in air through the bottom, and the fabric enters and leaves by a small aperture S, shown at the top left-hand corner of the apparatus, and passes between steam-heated pipes P, which prevent the formation of water. The rapid ager allows fabric to be treated at an average rate of about 60 yards per minute.

The treatment of the fabric is not finished with the ageing, however, for it has to undergo a further treatment for about a quarter of an hour at a temperature slightly below boiling-point in a bath containing 3 parts of bichromate and $\frac{3}{4}$ part of sulphuric acid in 1,000 parts of liquor. It is then rinsed, soaped, rinsed again, and dried, a black being produced which is exceedingly fast to light, bleaching, and washing.

BACTERIOLOGICAL USES

At the present time coal-tar dyes play a very important part in the science of bacteriology, and it is by their employment that the proper examination and differentiation of the numerous forms of bacteria has been rendered possible. When it is remembered what a large number of diseases are due to the action of pathogenic bacteria in the human body, the value of any substances which enable these diseases to be accurately diagnosed by facilitating the examination and identification of the particular organism concerned will be apparent. The most useful dyes or stains for bacteriological purposes are basic aniline dyes, although acid dyes are also employed in suitable cases, whilst it is necessary, in some cases, to use mordants, as in

dyeing cotton, the reason for this being that bacteria are minute vegetable organisms of a comparatively simple nature, and the composition of their protoplasm, therefore, obviously resembles that of vegetable fibres such as cotton.

Some of the most commonly employed aniline dyes are Methyl, Gentian, and Crystal Violet, Methylene, Thionin, and Victoria Blue, Fuchsin and Safranin as red stains, and Bismarck Brown, which, however, is not much used at present. Saturated alcoholic solutions of the dyes are usually employed, a small quantity of such solution being filtered and diluted with ten times its volume of distilled water for use. A film of serum or culture media containing bacteria is placed on a cover-glass, which is then floated on the dye solution in a watch-glass, or the dye is poured over the film on the cover-glass, and after a few minutes the surplus dye solution is washed off with distilled water. After washing, the wash-water is blotted off from the cover-glass with filter-paper, the film being then dried over a flame and covered with a drop of xylene balsam, when it is ready for mounting on a slide for microscopical examination. When viewed under a high-power microscope the size, shape, and structure of stained bacteria prepared in this way are clearly visible to the observer, and thus enable him to decide to which particular species the organisms under examination belong.

Some colours are more suitable for particular organisms than others; for instance, bacteria which are somewhat difficult to stain, such as the typhoid bacillus, require the use of violet or red dyes, which are more intensive than blues, although the latter are preferable in many cases, as they are not so liable to overstain. If a piece of fabric which is composed of a

mixture of wool and cotton is dyed with a non-substantive dye, the wool in the fabric absorbs and retains the dye much better than the cotton. This selective action is somewhat analogous to the action of dyes upon some bacteria which contain a nucleus, the latter absorbing the stain in a different degree to that of the general protoplasm of the bacteria. If the bacteria possess an envelope or capsule this also absorbs the dye in varying degrees, and the structure of the bacteria is thus exhibited. Eosine, which is an acid dye, is largely used in bacteriological work, especially for staining the tissues, when a section of the latter infected with bacteria is being examined, the bacteria themselves being contrast-stained with another dye, such as methylene blue. Mordants, such as metallic salts, phenol, and aniline oil, are used for fixing the dye in the bacteria, especially when it is desired to decolourise the surrounding tissues by mineral acids or alcohol, so as to enable the bacteria to be more clearly seen. The mordant may either be applied separately, or in the dye solution, good examples of the latter method being carbol thionin blue, which consists of a solution of 1 gramme of thionin blue in 100 cubic centimetres of phenol, and carbol-fuchsin, a very powerful dye made up of 1 part of basic fuchsin, 100 parts of a 1-in-20 solution of phenol, and 10 parts of alcohol, dyes of this kind being used for staining bacteria such as the tubercle bacillus. Mordants which are applied separately vary in composition, but a typical example consists of a mixture of tannic acid, corrosive sublimate, alum, and carbol-fuchsin; the latter constituent may, however, be replaced by the dye which it is intended to employ. Another widely used dye consists of a compound formed by mixing watery solutions of eosine and methylene blue together,

this being extensively employed for staining bacteria and protozoa in tissues. This latter dye is known as the Romanowsky Stain, many modifications of which have been developed for bacteriological use.

Inks. In addition to their bacteriological uses, coal-tar dyes are also largely used in the manufacture of inks. Blue and black writing inks which do not corrode metal pens, and are therefore specially used for stylographic pens, are made from a 1-in-80 watery solution of the sodium salt of sulphonated nigrosine, an azine dye made by heating aniline and aniline hydrochloride with nitrobenzene and a metal, and from induline blue, another azine dye, the composition of which is given in Chapter VIII.

Coloured writing inks are made from aniline dyes which are soluble in water, a 1-in-80 solution being usually employed, although this, of course, varies with the strength of the dye. Red inks are usually made from eosine, cotton scarlet, or erythrosin; yellow inks from tartrazin or Fast Yellow; green inks from Diamond Green G. or Neptune Green; blue inks from Soluble Blue T. or indigo, and violet inks from Acid Violet 4 BL. Methyl Violet in a very strong solution is employed for making indelible pencils, whilst indigo and aniline black are used as constituents of marking-inks. The copying and hectographic inks commonly employed are made from strong solutions of basic aniline dyes, any of which may be used, together with a small quantity of glycerine.

PHOTOGRAPHIC USES

Coal-tar dyes are now extensively employed for photographic purposes, in order to render sensitised

plates and films more sensitive to light rays of particular colours. The silver bromide used in preparing the sensitive emulsion is particularly susceptible to the influence of blue and violet rays, and, in order to make it almost equally responsive to other light rays, such as red, green, and yellow, the emulsion is treated with suitable dyes or is first applied to the plate or film, which is then placed in baths of the requisite dyes. Plates prepared in this manner produce what is termed a "panchromatic effect," but instead of this the plates may be rendered specially sensitive only to yellow and green rays when they are termed "orthochromatic."

Dyes of the phthalein series, such as eosine and erythrosin, are usually used for making orthochromatic plates, whilst a number of dyes are used as red sensitisers, among which are Formyl and Ethyl Violet of the Rosaniline series, and Nigrosin D. and Alizarin blue bisulphite. A number of azo dyes are also used as sensitisers, among which may be mentioned Pluto and Wool Black, Dianil Black R, Benzoinitrol Brown, and Glycin Red, whilst acridine dyes are blue and green sensitisers. Cyanin, which is a blue quinoline dye, is extensively used for making panchromatic plates, as it is too fugitive to be of any use as a dye for textile goods, whilst when mixed with quinoline red it forms a compound known as Azalin, which is used for making orthochromatic plates. Ethyl red, which is an isocyanin dye, when applied in very dilute solution, also produces panchromatic effects.

Dyes such as Erythrosin, Diamine pure blue, Aurophenin and Naphthol Yellow, are largely employed in the three-colour photographic process, whilst a number of dyes, such as Congo Red, Fuchsin, Methylene Blue, Auramine O., Naphthol Green, etc., are used for

making colour filters—that is, filters which will only allow light waves of a certain wave-length, and therefore colour, to pass through them, these colour filters or screens being essential for colour photography and cinematography.

X THERAPEUTIC USES

Within recent years certain artificial dye-stuffs have been found to possess therapeutic properties, and attempts have, therefore, been made to apply them to the cure of certain diseases. The employment of these substances for this purpose is known as Chemotherapy, and the dyes found to be of use in this connection include those of the benzidine group, and basic triphenylmethane dyes, such as Methyl Violet, whilst Eosine has also been used. Quite recently a dye known as Trypaflavine has been shown to possess remarkable antiseptic and healing properties.

It will thus be seen that artificial dye-stuffs are by no means confined in their usefulness to textile work, but have a wide and varied application which is likely to be still further extended in the future.

BIBLIOGRAPHY

Those wishing to pursue the subject of Artificial Dye-stuffs further are directed to the following books:—

- “The Synthetic Dye-stuffs and Intermediate Products.” Cain and Thorpe. 1913.
- “The Chemistry of the Coal-Tar Dyes.” I. W. Fay. 1911.
- “A Manual of Dyeing.” 2 volumes. Knecht, Rawson and Loewenthal. 1916.
- “The Analysis of Dye-stuffs.” A. G. Green. 1915.
- “The Manufacture of Organic Dye-stuffs.” A. Wahl, translated by F. W. Atack. 1914.
- “Aniline Black.” A. Morris. 1909.
- “The British Coal-Tar Industry.” W. M. Gardner. 1915.
- “Dyeing and Cleaning.” F. J. Farrell. 1908.
- “Tests for Coal-Tar Colours in Aniline Lakes.” Zerr and Mayer. 1910.
- “Chemistry and Physics of Dyeing.” Dreaper. 1906.
- “Synthetic Dye-stuffs and Coal-Tar Products.” G. Martin. 1916.
- “Bleaching and Dyeing of Textile Fibrous Materials.” Hübner and Meldola. 1912.
- “The Principles and Practice of Textile Printing.” Knecht and Fothergill. 1912.

INDEX

- Acetaminodimethylaniline, 170
 Acetyl-*p*-phenylenediamine, 66
 Acid Alizarin Blue, 84
 Acid Alizarin Green, 84
 Acid dye-stuffs, dyeing with,
 186, 187
 Acid Yellow, 44
 formula for, 45
 preparation of, 45
 Acid wool dyes, 83
 Acridine, 165
 dyes, 165
 dyes, general process for
 making, 166
 nucleus, 165
 Orange, 168
 Yellow, 168
 Adjective dye-stuffs, 176
 Ageing process, 195, 197
 for Aniline Black, 172
 Ager, rapid, 195, 197
 Alizarin, 3, 6, 8, 70, 81
 Blue, 86
 Blue S., 86
 Blue Bisulphite, 201
 Bordeaux, 82
 Brown, 79
 Cyanine R., 82
 Garnet, 80
 Green, 86
 Green S., 86
 Orange, 80
 Orange G., 83
 Paste, 76, 77
 Red S., 80
 Yellow FS., 66
 Alkali Brown (D.), 57
 Alpha compounds, 46
 Aluminium salts as mordants,
 78, 189
 Amethyst, 139
 Amidobenzoic acid, 93
 Amines, 33
 Amino radical, 33
 Aminoalizarin, 80, 86
 Aminoanthraquinone, 87
 Aminoazobenzene, 8
 formula for, 42
 nature of, 44
 Aminoazotoluene sulphonic
 acid, 60
 Aminobenzoic acid, 49
 Aminodimethylaniline, 134
 Aminonaphthol, 48
 Aminonaphthol-disulphonic acid,
 48
 Aminophenol, 49
 Aminophenyltrimethylammon-
 ium chloride, 64
 Amyl iodide, 175
 Aniline, 6, 95, 96
 discovery of, 37
 manufacture of, 37, 39, 40
 formula for, 37
 Black, 171
 Black, dyeing with, 195, 197
 Black, formula for, 173
 Blue, 116
 Blue, manufacture of, 117
 Yellow, 44
 Anilineazoethylparatoluidine,
 139
 Anisoline, 122
 Anthracene, 27, 28, 70
 Vat dyes, 87
 Anthrachryson, 83
 Anthragallol, 81
 Anthranilic acid, 49, 93
 Anthrapurpurin, 81
 Anthraquinoline derivatives, 82,
 86
 Anthraquinone, 71, 73, 75
 Black, 165
 -disulphonic acid, 81
 -monosulphonic acid, 75
 Aposafraanine, 141

- Arnica Yellow G., 68
 Aromatic molecules, structure of, 32
 Arylmethane dyes, 105
 Assistants in dyeing, 194
 Auramine, 107
 Aurantia, 173
 Aurophenin, 201
 Auxochromes, 31, 126
 Azalin, use of for orthochromatic plates, 201
 Azine compounds, chemical properties of, 126
 Azine dyes, 124
 Green, 139
 ring, 124
 Azo compounds, 42
 Azo dyes, 8
 discovery of, 29
 characteristic of, 29
 Azo group, 41
 Azo Turkey Red, 58
 Azochromine, 49
 Azofuchsine B., 50
 Azonium bases, 127
 formation of, 128

 Bacteriological uses of dyes, 197
 Basic dyes, dyeing with, 187
 Basic oxazine dyes, 143, 144, 145
 Basle Blue, 137
 Benzaldehyde, 166
 Benzaldehyde Green, 112
 Benzene, 23
 as base for indigo manufacture, 95
 Benzenediazo radical, 42
 Benzidine, 61
 dyes, therapeutical use of, 202
 Benzo Brown (5R.), 57
 Benzo Brown G., 66
 Benzo Grey, 65
 Benzoflavine, 166
 Benzonitrol Brown, 201
 Benzopurpurine 4B., 61
 Benzopurpurine 10B., 61
 Beta compounds, 46
 Bichromate of Potash, 73
 as mordant, 190
 Bichromate of sodium as mordant, 190
 Biebrich Scarlet, 60

 Bismarck Brown, 62
 Bleaching Fabrics, 178
 Bobbin dyeing, 183
 Bohn, 82, 87
 Boiling point of light oil, 18
 middle oil, 18
 heavy oil, 18
 anthracene oil, 18
 Brightening silk, 187
 Brilliant Alizarin Blue, 155
 Brilliant Croceine M., 60
 Brilliant Yellow, 63

 Cachou de Laval, 158
 Carbazole, 70, 163
 Catalyst, 172
 Celestine Blue B., 148
 Chicago Orange RR., 68
 Chloracetic acid in indigo manufacture, 96
 Chloranthrene Blue, 88
 Chloro-*p*-nitraniline, 64
 Chrome Violet, 117
 Chromic salts as mordants, 78
 Chromocyanines, 148
 Chromogens, 30
 Chromophores, 30
 Chrysaniline, 170
 Chrysoidine, 64
 Ciba Heliotrope, 99
 Cloth Red G., 60
 Cloth Scarlet G., 60
 Coal, distillation of, 16
 first patent for, 13
 for gas, 13
 for naphtha, 13
 Coal-tar, 18
 composition of, 14, 18
 distillation of, 16, 18
 distillation of by continuous process, 20
 from coke-ovens, 14
 products from distillation of, 14, 16
 Cochineal, 4, 10
 Coeruleine, 122
 Colouration of organic substances, 29
 Congo Blue 2B., 62
 Congo Corinth B., 62
 Congo dyes, 62
 Congo Fast Blue B., 65

- Congo Red dyes, 192
 Congo Red, 62
 Congo Red 4R., 62
 Cop dyeing, 183
 Copperas vat for indigo dyeing, 191
 Corioflavines, 171
 Cotton Brown (R.), 57
 Cotton dyeing, 188, 189, 190, 191, 192, 194, 195
 Cotton Orange R., 59
 Coupling, 42, 43
 solution for, 43
 Croceine Scarlet 7B., 60
 Crystal Violet, bacteriological use of, 198
 Curcuphenine, 69
 Cyanine, 175
- Dehydrothiitoluidine, 52
 formula for, 55
 Delphine Blue, 148
 Deltapurpurine 7B., 62
 Dephlegmator, 21
 Diamine Beta Black, 65
 Diamine Blue BB., 62
 Diamine Green B., 64
 Diamine Green G., 65
 Diamine Red 3B., 62
 Diaminoanthrachrysonedisulphonic acid, 84
 Diaminodimethylacridine hydrochloride, 168
 Diaminodimethylphenylacridine hydrochloride, 167
 Diaminodiphenylene, 61
 Diaminostilbene-disulphonic acid, 61
 Diamond Yellow R., 49
 Dianil Black R., 201
 Dianisidine, 61
 Diazo compound, 41
 Diazobenzene hydrochloride, 41
 Diazobenzene radical, 42
 Diazotisation, 41
 process of, 43
 Diethoxybenzidine, 61
 Diethylgallocyanine, 148
 Dihydroxyanthraquinone, 77, 79, 85
 Dihydroxybenzoic acid, 84
 Dihydroxydiphenylmethane, 67
- Dihydroxynaphthalene, 149
 Dimethyldiaminotoluphenazine hydrochloride, 133
 Dimethyl-*p*-phenylene diamine thiosulphonic acid, 151, 155
 Dinitroanthrachrysonedisulphonic acid, 84
 Dinitroazodistilbenedisulphonic acid, 68
 Dinitrostilbene sulphonic acid, 67
 Dioxynaphthalene sulphonic acid, 50
 Diphenazine, 126
 tautomeric form of, 127
 Diphenyl Green G., 64
 Diphenyl Orange RR., 69
 Diphenylethelene, 67
 Diphenylmethane derivatives, 105, 106
 Direct cotton dyes, 51
 Direct cotton dyeing, 192
 Disazo dyes, 58
 Distilbene molecule, 68
 Distilbene azo dyes, 192
 Disulphonic-benzeneazo- α -naphthylamine, 60
 Ditolyldiphenylmethane, 108
 Double coupling, 64
 Drebbel, 4
 Dyeing, assistants for, 194
 bacteriological method of, 198
 cotton, 188, 189, 190, 191, 192, 194, 195
 cotton cloth, 183
 machine for cops and bobbins, 183
 machine for hanks, 180, 183
 mordant dyes, 188
 piece goods, 183
 pile fabrics, 183
 silk, 186, 187, 189, 190
 with acid dye-stuffs, 186, 187
 with basic dyes, 187
 with direct dyes, 192
 with ingrain colours, 195, 197
 with sulphur colours, 194, 195
 wool, 186, 187, 189, 190, 191
 vat for hanks, 180
 Dyers Company, 4
 Dyes for three-colour process, 201

- Dyes from tetrazotised diamines,
60
used in bacteriology, 197
used in inks, 200
used in photography, 200, 201
used in therapeutics, 202
- Emeraldine, 172
- Eosine, 120, 121
bacteriological use of, 199
therapeutical use of, 202
- Erica B., 57
- Erythrosin, 121
use of, 201
- Ethyl bromide, 175
- Ethyl iodide, 175
- Ethyl Red, 175
- Ethyl Violet, photographic use
of, 201
- Ethylauramine, 107
- Ethylcyanin, 175
- Ethyl-*o*-toluidine, 154
- Ethyl-*p*-tolylenediaminethio-
sulphonic acid, 154
- Eurhodine, 131
- Eurhodines, 128
fluorescence of, 131
general process for making, 131
- Eurhodols, 128
general process for making, 135
- Fast Black, 149
- Fast Brown, 59
- Fast Green M., 149
- Fast Red A., 47
- Fast Violet R., 60
- Fast Yellow B., 45
- Ferric salts as mordants, 78
- Flavanthrene, 87
- Flaveosine, 170
- Flavinduline, 142
- Flavopurpurin, 81, 83
- Fluorescein, 118, 119, 120
- Fluorescence of Eurhodines, 131
- Formaldehyde, 168
- Formyl Violet, photographic use
of, 201
- Fractional distillation, 20, 21
- Fuchsine, 7, 111
- Galleine, 122
- Gallic acid, 146
- Gallimide, 148
- Gallocyanine, 147
- Gamboge, 10
- Gentianine, 153
- Glauber's salt, use of in dyeing,
186, 194
- Glycerol, 174
- Glycin Red, 201
- Glyoxal, 130
- Graebe, 8, 70
- Green, A. G., 172
- Green's process for Aniline
Black, 172
- Halogenised indigo dyes, 97, 99
- Hank dyeing by hand, 180
by machine, 180, 183
- Heckman's still, 21
- Hessian Brown BB., 67
- Hessian Yellow, 63
- Heterocyclic ring, nature of, 124
dyes, 124
- Hexabromindigo, 99
- Hexagon formula, explanation
of, 32
- Hexahydroxyanthraquinone, 79
- Hexanitrodiphenylamine, 173
- Hofmann, A. W., 7, 112
- Hofmann's Violet, 113, 115
manufacture of, 114
- Hydroacridine, 167
- Hydron Blue, 163
- Hydrosulphite vat for indigo
dyeing, 190
- Hydroxydiphenylamine, 149
- Hydroxyl, 42
- Imino radical, 131
- Immedial Brown B., 158
- Immedial Green, 162
- Immedial Orange C., 160
- Immedial Pure Blue, 162
- Immedial Yellow GG., 158
- Indalizarin, 148
- Indamines, 131
- Indanthrene, 87, 88
Yellow, 87
- Indigo, 2, 6, 9, 97
manufacture of, 89, 95, 96
constitution of, 95
dyeing, 190, 191
dyeing machine, 192

- Indigo, dyeing vats, 192**
 Carmine, 97
 Red, 99
 sulphonic acid, 97
 White, 97
Indirubin, 99
Indoin Blue, 140
Indophenol, 162
Indoxyl, 99
 constitution of, 94
 manufacture of, 94
Induline, 141
Induline Scarlet, 139
Indulines, 129
Ingrain colours, dyeing with,
 195, 197
 Brown, 57
 Orange, 57
 Red, 57
Inks, dyes used for, 200
Iodine Green, 115
Iron Buff, 10
Isatin, 99
Isomerism of dye-stuffs, 32
Isopurpurin, 81
Isoquinoline, 174
Italian Green, 160
- Janus Brown B., 64**
Jet Black R., 60
Jigger, 183
- Kekulé, 108**
Ketones, 130
- Lakes, 50**
Lanacyl Blue BB., 48
Lanuginic acid, 186
Lepidine, 175
Lepidinquinolineamyl-cyanin-
 iodide, 175
Levinstein, 11
Liebermann, 7, 70
Light oils, purification of, 20, 21
Lithol Red, 51
Logwood, 10
- Madder, 2, 3, 6, 70**
Magdala Red, 146
Magenta, 66, 111
 manufacture of, 112
Malachite Green, 112
 Malachite Green, manufacture of,
 . 113
Manchester Brown, 62
Manganese Brown, 10
Martin's Yellow, 173
Mauveine, 140
Mekong Yellow G., 67
Meldola's Blue, 144
Mercury, use of in indigo manu-
 facture, 90
Meso ring, 127
Mesophenyl-dianilinoaminodi-
 phenazonium chloride, 141
Mesophenyl-tetraanilinophen-
 azonium chloride, 142
Mesophenyl-trianilinophen-
 azonium chloride, 141
Metanilic acid, 59
Methane, 125
 constitution of, 105
Methyl Violet, 114, 115
Methylauramine, 107
Methylene Blue, 150
 process for making, 150, 151,
 152
Methylene Green, 153
Methylene Violet, 137
Methylethylaniline, 154
Methylgallate, 148
Methylquinoline, 175
Middle component, 59
Mikado Orange, 69
Mikado Yellow L., 68
Mixed diazo dyes, 61
Monogenetic dye-stuffs, 177
Mordant dyes, dyeing with, 188
Mordant oxazine dyes, 146
Mordants, 4, 50
 action of, 77, 78, 178, 188, 189
 bacteriological use of, 199
Muscarine, 149
- Naphthalene, 25, 46, 70**
 sublimation of, 26
 as base for indigo manufac-
 ture, 89
Naphthaphenanthrazine - α - sul-
 phonic acid, 135
Naphthaquinone sulphonic acid,
 155
Naphthionic acid, 47
Naphthol, β -, 47

- Naphthol disulphonic acid, 47
 Naphthol Yellow R.S., 173
 Naphthol Yellow S., 173
 Naphthylamine Black D., 60
 Naphthylamine sulphonic acid,
 51
 Naphthylaldiphenylmethane, 108
 Naphthylene Red, 63
 Neutral Red, 132
 Neutral Violet, 134
 New Blue R., 144
 New Methylene Blue, 146
 New Methylene Blue N., 153
 Nigraniline, 172
 Nigrosine, 141
 Nile Blue A., 145
 Nitraniline, 58
 Nitration, 79
 Nitro dyes, 173
 Nitro group, 34
 Nitroalizarin, 80, 86
 Nitrobenzene, constitution of, 34
 manufacture of, 34, 35
 Nitroflavopurpurin, 83
 Nitrosodiethylaminophenol, 145
 Nitrosodimethylaniline hydro-
 chloride, 132

 Obermaier dyeing machine, 180
 Oriol Yellow, 57
 Orthochromatic plates, dyes
 used for, 201
 Oxamine Red, 62
 Oxazine dyes, 143
 general method for producing,
 144
 ring, 143
 Oxydising agents for Aniline
 Black, 172³

 Padding, 58
 Palatine Red, 47
 Para-aminoazo compounds, 59
 Paranitraniline Red, 58
 Pararosanine, 109, 110
 chloride, 110, 111
 Pentabromindigo, 99
 Pentahydroxyanthraquinone,
 79, 82
 Pentamethylpararosanine
 hydrochloride, 114
 Perkin, Sir W. H., 7

 Phthalic acid, 90
 constitution of, 92
 anhydride, 92, 93, 170
 Phthalimide, 92, 93
 Phenanthranaphthaeurhodol,
 135
 Phenanthraquinone, 142
 Phenanthrene, 70
 Phenazine, 125
 Phenocyanines, 148
 Phenocyanine TC., 148
 Phenocyanine TV., 148
 Phenocyanine VS., 148
 Phenol, 27
 purification of, 27
 Phenolphthalein, 118
 Phenosafranine, 136
 purification of, 137
 Phenosafranone, 164
 Phenyl radical, 105
 Phenyl- α -naphthylamine, 60
 Phenylauramine, 107
 Phenylenediamine, 59
 Phenylglycine, 96
 Phenylglycine-*o*-carboxylic acid :
 manufacture of, 93
 constitution of, 94
 Phenylphenosafranine, 140
 Phosphine, 171
 Photographic uses of dyes, 200
 Picric acid, 10, 173
 action of as a dye, 177
 Pile fabrics, dyeing, 183
 Pluto Black, 201
 Polygenetic dye-stuffs, 177
 Ponceau ARB., 60
 Primary Disazo dyes, 58
 Primuline, 51, 155
 bases, 55
 dyes, 192
 formula for, 56
 manufacture of, 52, 54
 Red, 57
 Products of fractional distilla-
 tion, 23
 Prune, 148
 Prussian Blue, 10
 Purpurin, 81
 Pyrazine, 125
 Pyridine, 28
 Pyrocatechol, 129
 Pyrogallol, 49

- Pyrone dyes, 118
Pyrone ring, 119
- Quinaldine, 175
Quinizarin, 85
Quinizarin Green, 85
Quinoline, 28
 dyes, 174
 formula for, 174
 Yellow, 175
- Quinone, 30
Quinonoid structure of dye-stuff
 molecule, 30
 nature of azines, 127
- Rapid ager for aniline black,
 195, 197
- Reducing agents for vat dyes,
 190, 191
- Redwood, 10
Resorcin, 59
Resorcin Brown, 59
Rheonine, 169
Rhodamine, 121, 122
Rhodamine B., 121
Rhodamine G., 122
Rhodamine 3B., 122
Ricinoleic acid, 78
Romanowsky stain, 200
Rosaniline chloride, 66, 111
Rosindulines, 128
Rosolane, 141
Rosophenine 10B., 57
Runge, 7
- Safranine, 107, 128
 method of producing, 135
Safronols, 128
Salicylic acid, 49, 50
Saxony Blue, 97
Second component, 42
Secondary disazo dyes, 59
Silk dyeing, 186, 187, 189, 190
Simple azines, production of,
 129, 130
Sky Blue, 162
Sodamide, 96
Sodium hydroxide, 68
 polysulphide, 157
 sulphide, solubility of sul-
 phide dyes in, 157
Stannic salts as mordants, 78
- Stilbene, 67
 dyes, 67
 residue, 67
 Yellow, 69
 Yellow 8G., 68
- Substantive dyes, 51, 176
Substitution products, 33
Sulphanilic acid, 66
Sulphide dyes, nature of, 157
 general method for making,
 157
Sulphonation, 44, 79
Sulphonic group, 44
Sulphur dyes, dyeing with, 194
Sun Yellow, 69
Symmetrical diazo dyes, 61
- Tannin as mordant, 107, 188,
 190
Tartar emetic as mordant, 107
Terra-cotta F., 58
Terra-cotta G., 57
Tetrabromindigo, 99
Tetrabromindirubin, 99
Tetrabromofluorescein, 120
Tetrachlorindigo, 99
Tetrahydroxyanthraquinone,
 79, 82, 83
Tetrakisazo dyes, 66
Tetramethyldiaminobenzo-
 phenone, 169
Tetramethyldiaminodiphenyl-
 methane chloride, 113
Tetraaminoditolyphenylacri-
 dine, 167
Tetrazo compounds, 61
Therapeutic use of dyes, 202
Thiazine dyes, 150
Thiazine ring, 150
Thiazole dyes, 155
Thiazole ring, 155
Thioflavine T., 156
Thiogen Violet V., 164
Thioindigo, 100
 Red, 101
 Scarlet, 103
Thionine Blue G., 154
Tolidine, 61
Toluene, 23, 24
Toluidine, 50
Toluylene Brown R., 67
Tolyldiphenylmethane, 108

- Tolylene Blue, 132, 133
 Tolylene Red, 132
 Tolylenediamine, 133, 160
 Tolylenediamine-4-sulphonic acid, 67
 Tolylnaphthylenediamine, 137
 Triaminotriphenyltolylcarbinol hydrochloride, 111
 Triaminotriphenylcarbinol, 109
 Tribromindigo, 99
 Trichlorindigo, 99
 Triethylrosaniline hydrochloride, 113
 Trihydroxyanthraquinone, 79, 81
 Trinitrotriphenylmethane, 109
 Tri-*p*-nitrotriphenylcarbinol, 109
 Triphenylcarbinol, 109
 Triphenylmethane:
 dyes, nature of, 108
 dyes, therapeutical use of, 202
 nature of, 107
 preparation of, 108
 Triphenylrosaniline Chloride, 116
 Trisazo dyes, 63, 64, 65, 66
 Tritolylmethane, 108
 Turkey Red, 77, 189
 oil, 189
 Turmeric, 10
 Tyrian dyes, 2, 3
 Unverdorben, 6
 Uranin, 120
 Vat dyes, 87, 97
 dyeing with, 190
 Verguin, 7
 Victoria Blue B., 116
 bacteriological use of, 198
 Vidal Black, 164
 Von Baeyer, 9, 89
 Water-eosines, 121
 Water, treatment of, for dyeing, 178
 Woad, 1, 2
 Woading, 172
 Wool Black, 201
 Wool Dyeing, 186, 187, 189, 190, 191
 Xylene, 24, 59
 Xylidine, 59

University of California Library
or to the
NORTHERN REGIONAL LIBRARY FACILITY
Bldg. 400, Richmond Field Station
University of California
Richmond, CA 94804-4698

ALL BOOKS MAY BE RECALLED AFTER 7 DAYS

- 2-month loans may be renewed by calling (510) 642-6753
 - 1-year loans may be recharged by bringing books to NRLF
 - Renewals and recharges may be made 4 days prior to due date.
-

DUE AS STAMPED BELOW

DEC 26 1996

RETURNED

DEC 05 1996

Santa Cruz

RECEIVED

DEC 09 1996

CIRCULATION DEPT.

12,000 (11/95)

OCT 28 1972

LOAN LDR HC m-5, '43 (6061s)

397955

Ramsey

UNIVERSITY OF CALIFORNIA LIBRARY

