

AUTOMATIC SPRINKLER
PROTECTION

▼
GORHAM DANA, S. B.

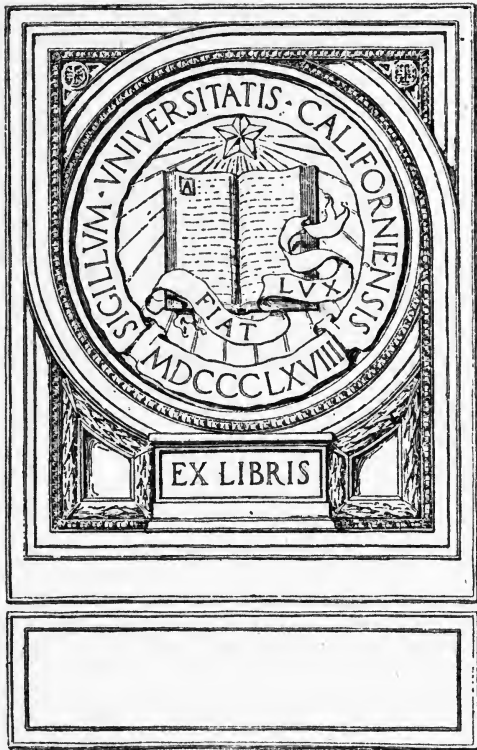



EX LIBRIS



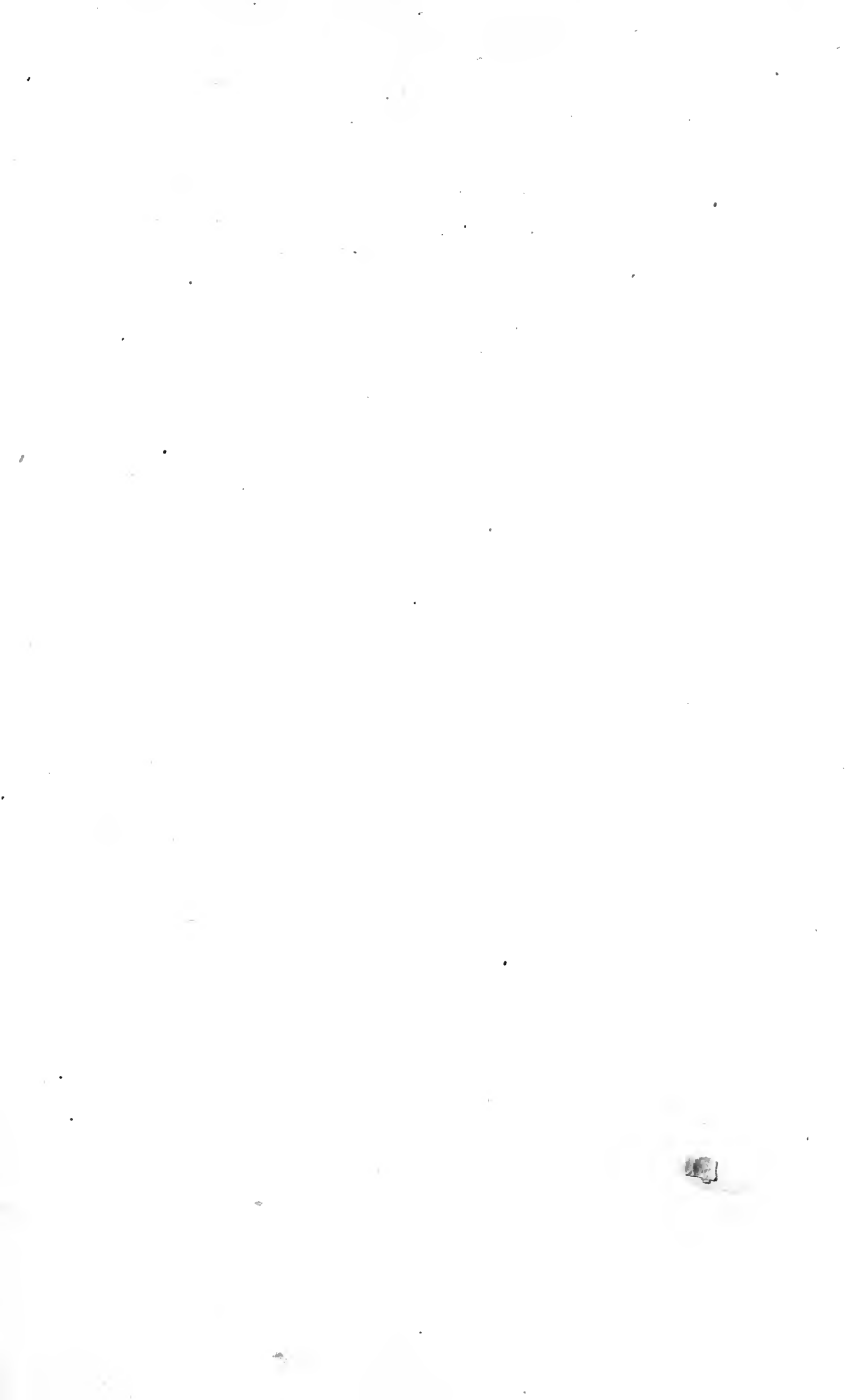

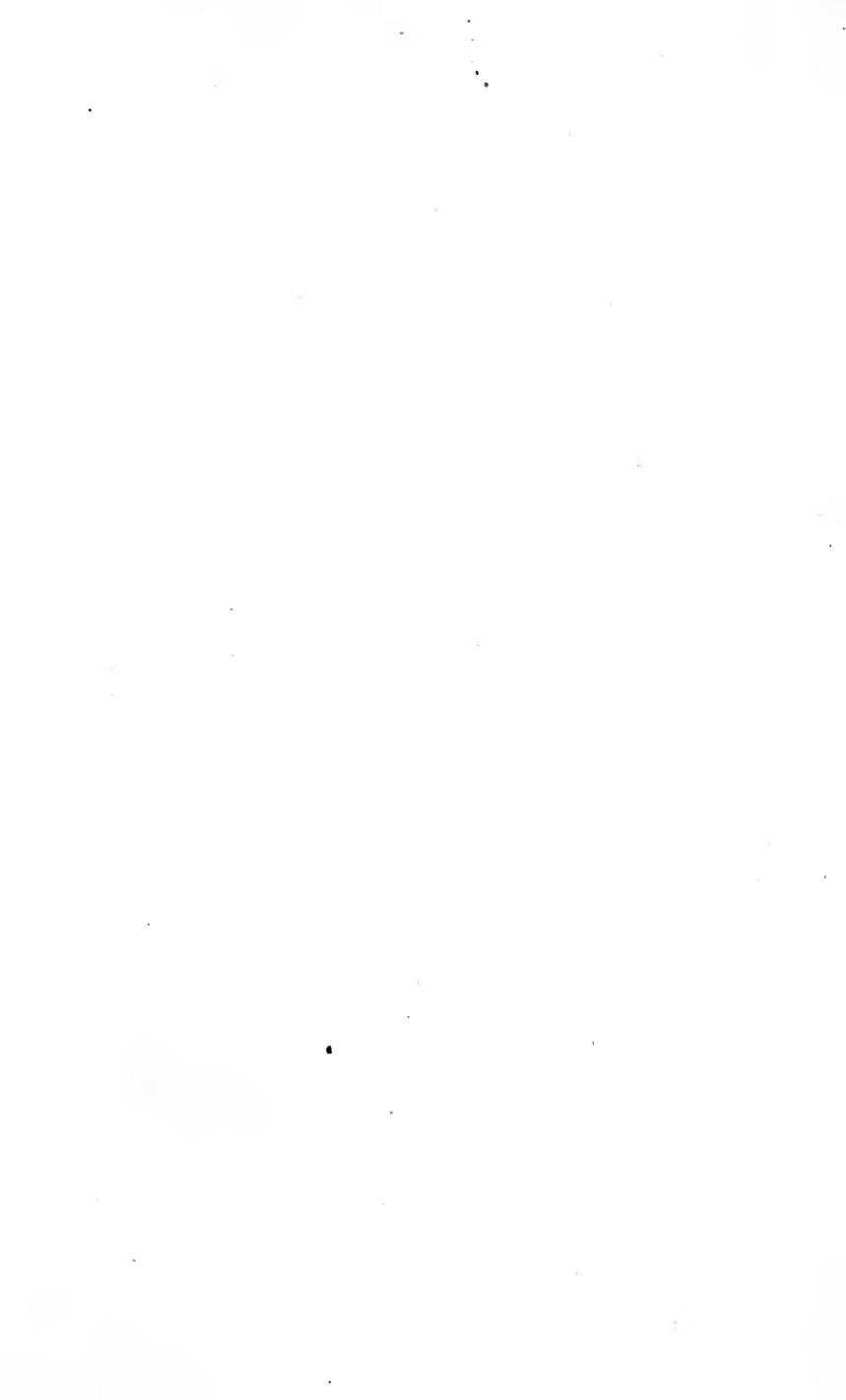



AUTOMATIC SPRINKLER PROTECTION

BY

GORHAM DANA, S. B.

MANAGER, THE UNDERWRITERS' BUREAU OF NEW ENGLAND,
BOSTON, MASSACHUSETTS

SECOND EDITION



NEW YORK

JOHN WILEY & SONS, INC.

LONDON: CHAPMAN & HALL, LIMITED

1919

12/17/19

TH9336
D3
1919

COPYRIGHT, 1914, 1919.
BY
GORHAM DANA

TO THE
LIBRARY OF THE
STANBOPE PRESS

Stanbope Press
F. H. GILSON COMPANY
BOSTON, U.S.A.

PREFACE

THIS book is based on a series of lectures delivered by the writer before the Insurance Library Association of Boston in the spring of 1913. These lectures covered the third year course in the subject of Fire Protection as outlined by the Insurance Institute of America. In this book the lecture notes have been greatly amplified in an effort to cover more thoroughly all phases of the subject.

There has been added an appendix in which all sprinkler heads, about which any information could be obtained, are listed alphabetically, and briefly described. Several years ago the writer listed and photographed the sprinkler heads shown in the first edition of the Crosby-Fiske Hand Book of Fire Protection, these being taken largely from the collection owned by the Underwriters' Bureau of New England. These were afterwards re-photographed and a number were added. The authors of the Hand Book have kindly loaned these cuts for use in the appendix. A number of new types and variations of old types have been added to this list but as the names and numbers as given in the Hand Book have become quite generally recognized throughout the country, care has been taken not to change these and fractional numbers have in some cases been used to designate sprinklers that have come to notice since these photographs were taken.

Having been a member of the Committee on Automatic Sprinklers of the National Fire Protection Association for several years, the writer has had an opportunity to keep in touch with all the late developments in this interesting art.

The aim of the book is to cover the subject in such a way that it can be used as a text book for persons studying sprinkler protection and as a reference book for those already versed in it.

Assistance, which is gratefully acknowledged, has been received from Mr. E. V. French, Vice-President of the Arkwright Mutual Insurance Company; Mr. C. W. Mowry, Engineer, Factory Mutual Ins. Cos.; Mr. Russell Grinnell, Vice-President of the General Fire Extinguisher Company; Mr. J. C. Meloon, Mechanical Engineer with the same company, Mr. A. M. Lewis of the Associated Automatic Sprinkler Co., and others. Mr. C. J. H. Woodbury's report on Automatic Sprinklers made in 1884 has been freely quoted and much valuable information was obtained from this and other articles by Mr. Woodbury. Mr. C. C. Johnson of the American District Telegraph Company and Mr. George H. Spooner gave valuable assistance on the subject of Sprinkler Supervisory Systems.

To Messrs. Fiske and Crosby, the General Fire Extinguisher Company, several other sprinkler companies, the American District Telegraph Company and others the writer is indebted for many of the illustrations. Much valuable data on English sprinklers was obtained from Mather & Platt, Ltd., London, Agents for the Grinnell devices.

It has been very difficult in some cases to verify the data obtained from doubtful sources and for this reason corrections and criticisms will be especially welcomed by the author.

GORHAM DANA.

January, 1914.

In preparing the second edition the text was thoroughly revised and information on new devices was added. New chapters have also been added on Combined Heat and Sprinkler Systems and Sypho Chemical Sprinkler Systems.

G. D.

May, 1918.

TABLE OF CONTENTS

	PAGE
INTRODUCTION.....	ix
CHAPTER I. — PERFORATED PIPES.....	1
Francis; Whiting; Grinnell; and Hall systems. Pipe scheme. Defects. Fire Record.	
CHAPTER II. — EARLY AUTOMATIC SYSTEMS AND SPRINKLERS.....	10
Godfrey; Carey; Congreve; Macbay; Pratt; Souther and Meehan systems. Harrison; Parmelee; Conant; Buell; Barnes; Bishop; Burritt; Whiting; Granger; Brown; Mackey; Harris; Kane; Draper; Walworth; Ruthenburg; Grinnell; and other sprinklers.	
CHAPTER III. — LATER DEVELOPMENTS IN AUTOMATIC SPRINKLERS.....	42
Types. Mascot; Nagle; Shaw; Bishop; Brown; Buell; Star; Clapp; Hill; Gray; Hibbard; Harkness; Kane; International; Associated; Evans; Kersteter; Mackey; Manufacturers; Neracher; N. Y. & N. H.; Newton; Phoenix; Pierce; Rockwood; Walworth; Esty; Babcock; Grinnell; and other sprinklers.	
CHAPTER IV. — TESTS AND CHARACTERISTICS OF SPRINKLERS.	67
Woodbury tests. Sprinkler solder. Leakage. Fire record. Later Mutual tests. Approved sprinklers. Size of orifice. Failures from age. Limit of age. Corrosion. Painting. Rotating deflectors. Valve discs. High-test heads. Defective heads in use. Cost of equipments. Tests for acceptance. Requirements for construction. Test specifications.	
CHAPTER V. — INSTALLATION RULES.....	88
General information. Location. Circulation in pipes. Service connections. Painting. Hanging and piling of stock. Extra sprinklers. Hand hose. Spacing. Pipe sizes.	

	PAGE
CHAPTER VI. — LAYOUT OF EQUIPMENTS.....	107
<p>Feed mains and risers. Valves and fittings. Hangers. Test pipes. Drip pipes. Pressure gages. Protection against freezing. Water supplies. Waterworks. Meters. Gravity tanks. Pressure tanks. Steam pumps. Rotary pumps. Centrifugal pumps. Electric pumps. Steamer connections. Underground pipe.</p>	
CHAPTER VII. — ALARM VALVES.....	137
<p>Types. Installation. Rules for designing alarm valves. Installation rules. Fire record. Associated; Carpenter; Crowder; Evans; Gray; Globe; Grinnell angle; Grinnell English; Grinnell Straightway; Harkness Tee; International; Manufacturers or Venturi; Neu; Niagara; Rockwood; Walworth alarm valves.</p>	
CHAPTER VIII. — DRY VALVES.....	184
<p>General features. Types. Installation rules. Early systems. Requirements for a dry valve. Associated; Brown; Cataract; Clapp; Clayton; Crowder; Dixon; Dodge; Globe; Gray; Grinnell bellows; Grinnell No. 12; Grinnell Straightway; Hibbard; Higgins; Ideal; Independent; International; Kane; Kersteter; Linn; Mackey; Manufacturers; Nagle; Neracher; Nyasco; N. Y. & N. H.; Niagara; Phoenix; Richmond; Rockwood; Shaw; Steck; U. T. D.; and Walworth dry valves. Combined sprinkler and heating system.</p>	
CHAPTER IX. — SPRINKLER SUPERVISORY SYSTEMS.....	260
<p>Installation rules. Description of devices. Water flow apparatus. Gate valve attachment. Pressure indicator. Water level device. Temperature device. Supervision by water flow.</p>	
CHAPTER X. — MAINTENANCE AND FIRE RECORD.....	288
<p>Inspection methods in use. Care of valves. Drip valve tests. Tanks and pumps. Dry valves and alarm valves. Sprinkler systems. Tests of sprinkler heads. Self-inspection. Fire record. Important fires.</p>	
CHAPTER XI. — SPRINKLER LEAKAGE.....	310
<p>What should be inspected. Policy form.</p>	

CONTENTS

vii

	PAGE
CHAPTER XII. — AUTOMATIC SPRINKLERS AS A PROTECTION TO LIFE	322
Record of loss of life in sprinklered risks. Need of legis- lation.	
CHAPTER XIII. — COMBINED HEAT AND SPRINKLER SYS- TEMS	326
CHAPTER XIV. — SYPHO CHEMICAL SPRINKLER SYSTEM.....	340
APPENDIX I.....	353
List of over 250 sprinklers described and rated.	
Result of tests on 6277 old types of sprinklers.	
APPENDIX II.....	439
Standard report blank for Inspection by the assured.	



INTRODUCTION

AUTOMATIC sprinklers have now been on the market for over forty years and while the early types were crude and unreliable they have now been so perfected that little remains to be desired. The development was due largely to the ingenuity of a number of inventors, including Parmelee, Grinnell, Barnes, Bishop, Buell, Gray and

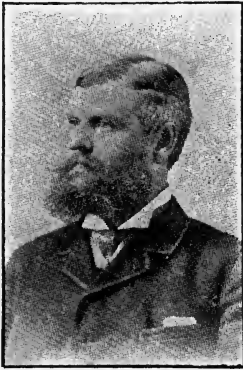

HENRY S. PARMELEE.



FREDERICK GRINNELL.

Kane, but also in no small degree to the work of the fire protection experts connected with the fire insurance companies. The thorough tests made in the insurance laboratories, the advice given as a result of these tests and the study they involved were important factors in the development. The rebate allowed by the insurance companies for sprinkler protection was undoubtedly the most powerful factor in the growth of the business and without this rapid increase in their use, the development of the devices would have been much slower.

While the first practical automatic sprinkler was designed in England, it may be considered an American invention for the first sprinkler to be used in practice was invented here and most of the early development took place in this country.

The Stock Insurance Companies were rather slow in taking up the idea and much of the early development is due to the Associated Factory Mutuals — a group of mutual insurance companies devoting most of their attention to large manufacturing plants. The foresight of their officials and the exhaustive tests made by their laboratory staff did much to bring the sprinkler into prominence.

The National Board of Fire Underwriters, comprising all the leading Stock Insurance Companies doing business in this country, appointed a committee in 1875 to report on this subject. This committee consisted of Wm. H. Ross, John E. Kahl, James Nichols, Geo. P. Field and John A. Child. The following quotation is taken from their able report:

“Another patented improvement on this principle comes up for examination, viz. the Automatic Fire Extinguisher and Alarm which appears to be nearly all that is required, an apparatus in all places, sufficient in itself, always ready, always there to act entirely by itself and which cannot go to sleep or make blunders.”

No further action was apparently taken by the Stock Companies for about 10 years, although some of the individual companies did take some interest in property so protected. In 1886 the New England Insurance Exchange, the rating body for New England, appointed a special committee to report on Automatic Sprinklers. As a result of this report the Factory Improvement Committee was appointed the same year “to prescribe requirements, approve devices, encourage standard construction, and fix rates.”

Mr. U. C. Crosby of Boston, Chairman of this Committee was one of the first Stock Company insurance representatives to become interested in the device and his work, together with the valuable tests made by his son Everett U. Crosby at the Underwriters' Bureau of New England, did much to popularize the sprinkler among Stock Companies.

In the early days, tests for acceptance were made by a number of local boards and bureaus and different devices were approved in different parts of the country.

In 1901 the Underwriters' Laboratories, Incorporated, of Chicago, a corporation supported largely by the National Board of Fire Underwriters, took over practically all the testing of sprinklers for the Stock Companies. The splendid work of this organization has done much to bring automatic sprinkler protection to its present high state of development.

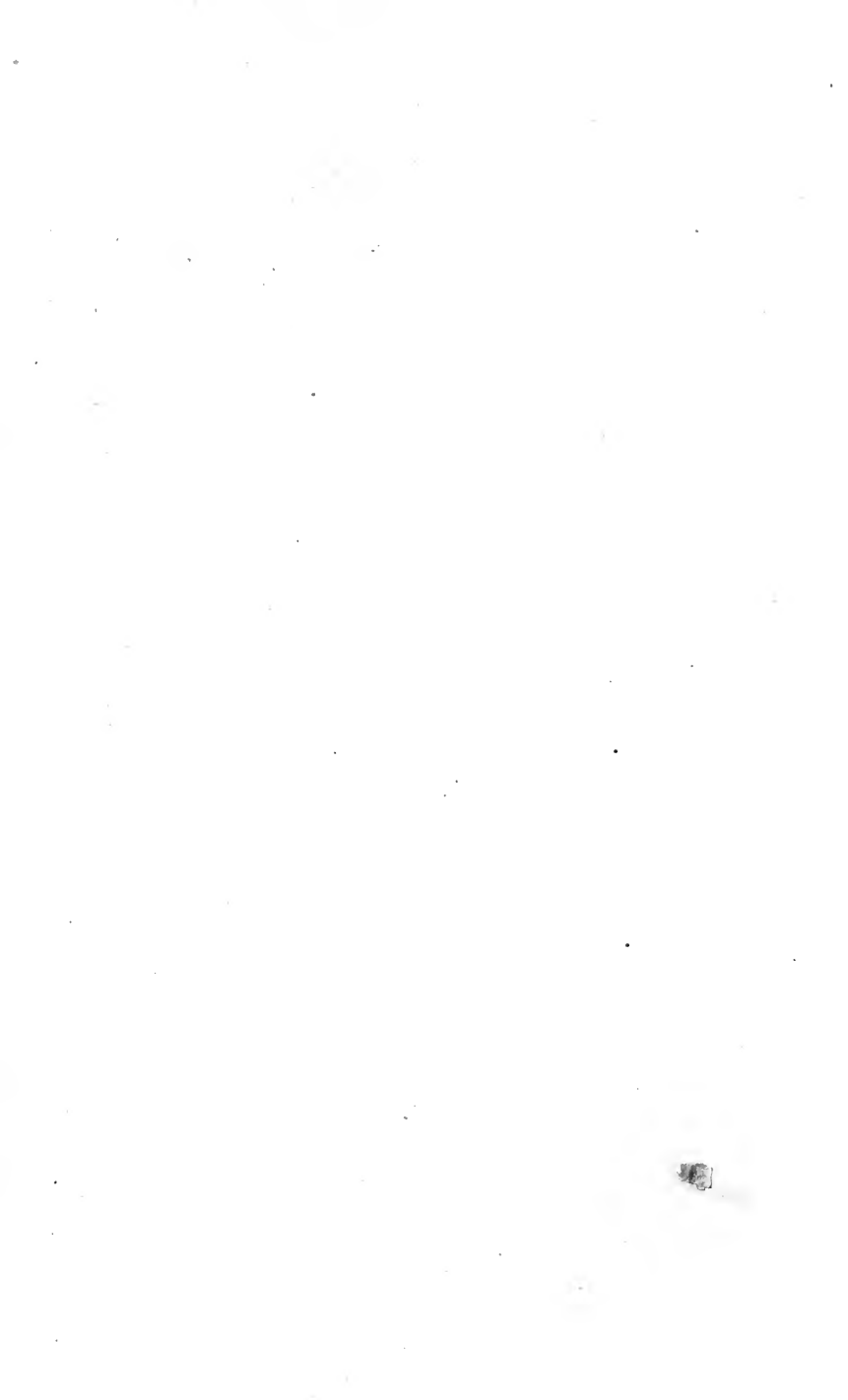

AUTOMATIC SPRINKLER PROTECTION

CHAPTER I

PERFORATED PIPE SYSTEMS

Francis System. The first form of sprinkler to be used in practice was the perforated pipe. These systems were first used in this country about 1852, the idea having been apparently imported from England. The first installation on record was made at a plant of the Proprietors of the Locks and Canals on the Merrimack River at Lowell, Mass. The early equipments were installed to protect the roofs of mill buildings only; but later they were extended to picker, card and spinning rooms of textile mills. In 1859 the Locks and Canals Company was requiring perforated pipes in all hazardous and certain inaccessible rooms in their mills. Mr. James B. Francis, the hydraulic engineer for this company, early saw the possibilities of such a system and made experiments to determine the best size and location of perforations; the proper size of feed pipes and branch lines; and the best location of the pipes.*

He developed a system in which the piping was placed close to the ceiling, running across the mill in the center of each bay. The pipe was perforated with holes $\frac{1}{16}$ inch in diameter, placed 9 inches apart alternately on different sides and at a point a little above the horizontal center of the pipe. This caused the water to be discharged toward the ceiling at an angle which would wet the ceiling to advantage as well as properly cover the floor below. In order to reduce the friction loss of the water in the pipes it was found necessary to grade

* See Journal of Franklin Institute, April, 1865.

2. AUTOMATIC SPRINKLER PROTECTION

the pipe sizes so that the area of the cross section at any point was about twice the area of the perforations to be supplied. Such a system under 20 pounds pressure would discharge enough water to cover the floor to a depth of $\frac{1}{4}$ inch in a minute.

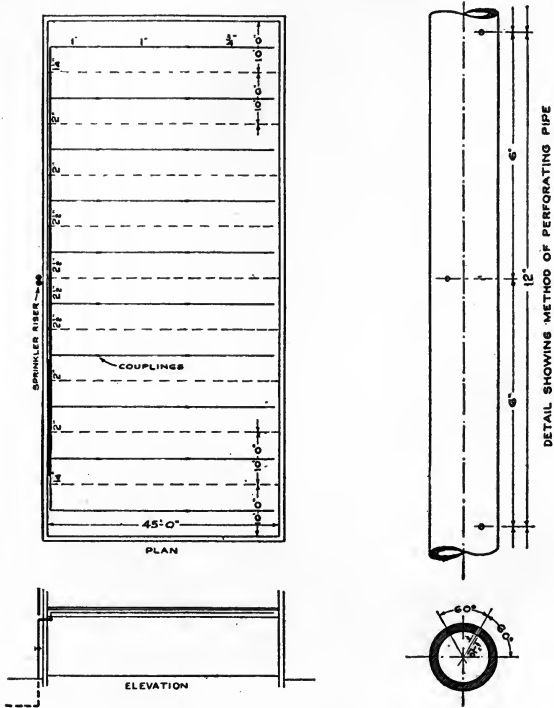

FRANCIS SYSTEM

of perforated pipes installed by Providence Steam and Gas Pipe Co.

Prior to 1870 the Providence Steam & Gas Pipe Company became interested in fire protection and began installing the Francis system of perforated pipes in mill property. Soon after 1870 the Francis system was, in existing installations, very generally extended to cover

picker, card and spinning rooms as well as other rooms where processes of a hazardous nature were carried on.

The Boston Manufacturers Mutual Insurance Company bulletin for 1880 advised the Assured to make cer-

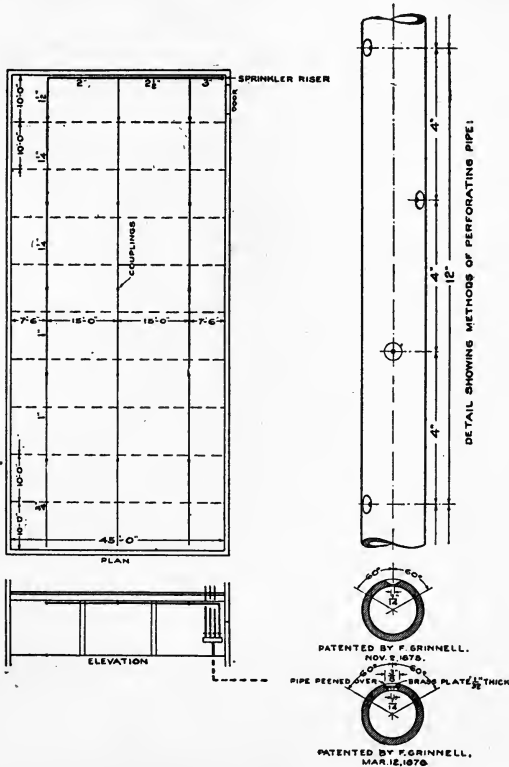

GRINNELL SYSTEM

of perforated pipes installed by Providence Steam and Gas Pipe Co.

tain that the pipe sizes of their perforated pipe systems, where supplied from a reservoir, were of such a size that the area of the orifices would not exceed 50 per cent that of the area of the pipe that fed them; but

that where the supply was from pumps, the area of the orifices might be 66 per cent that of the area of the pipe.

Whiting System. Mr. William B. Whiting modified this system by using holes $\frac{1}{2}$ inch in diameter and placing them 3 inches apart alternately on the top of the pipe and at a point 30 degrees from the vertical on each side. The pipes were run across the bays and under the beams.

Grinnell System. About 1873 the Providence Steam & Gas Pipe Company further modified the system by using holes $\frac{1}{4}$ inch in diameter in three rows 12 inches apart on the row and staggered, so that the holes were 4 inches apart between centers on the line of pipe. The center row of holes was at the top of the pipe and the two side rows were at an angle of 60° from the vertical. Standard wrought-iron pipe was used for all the lines that were perforated. Boiler tubing with fine threads and long bend fittings was used for the feed pipes.

In 1875 Frederick Grinnell, president of the Providence Steam & Gas Pipe Company, devised a countersunk orifice for the perforations which tended to prevent clogging of the outlets by corrosion. In 1878 he still further improved the system by using a non-corrosive orifice consisting of a thin plate $\frac{3}{8}$ inch in diameter and $\frac{3}{2}$ inch thick with a $\frac{1}{4}$ -inch hole in the center. This was placed over the outlets in the pipe and held by being peened into the pipe with a hammer.

Hall System. Between 1870 and 1875 there was considerable competition in the business and Hall Brothers of Boston began to install systems where the perforated pipes were of galvanized sheet metal with slip joints similar to stovepipe joints. These were attached to wrought-iron feed pipes. This made a cheap installation but the sheet-iron pipe was not well suited to withstand severe corrosion or heavy pressure. Many of

the joints pulled out under pressure and the system was soon given up.

Pipe Scheme. In all these systems the general scheme of piping was the same. Starting at one end of a room the piping was run in parallel lines 10 feet or less apart beginning with $\frac{3}{4}$ -inch pipe and gradually enlarging so that the diameter of the pipe at any point would comply with the rules given above. These lines of pipe connected with a feed pipe which in turn was enlarged until the riser or upright pipe feeding the entire floor was reached. This riser passed down through the floors or on the outside of the building to a controlling valve.

Each floor had a separate riser and controlling valve. These valves were located in a group, each one being labelled, showing which floor or section it controlled. In the best laid out systems these valves were housed in a valve house at a safe distance from the mill building. The valves being underground were operated by hand wheels on a spindle and a light was constantly kept burning so that the labels could be quickly read. In other systems the valves were either in the building or on the outside according to the location of the risers. Sometimes the valve stem extended through the wall. Where the valves were in stair towers the arrangement was much safer than where they were in the main building. Any location except the detached valve house was undesirable and this defect of location was the cause of many failures, owing to the impossibility of reaching the valves after the fire was discovered. The valves were, of course, kept closed and in well laid out systems the water was under constant pressure in the pipes up to those controlling valves.

If there was a hydrant system in the yard the perforated pipe system could be connected with the hydrant piping provided it was of sufficient size and capacity,

care being taken to keep all piping up to the valves below frost line.

The water supplies used were generally reservoirs or pumps, but sometimes public waterworks systems and elevated tanks were used. Where elevated tanks were used it was quite necessary to have pumps in reserve in order to obtain sufficient capacity to supply the system for any length of time. Systems depending upon pumps alone were not as desirable on account of the delay that would probably be experienced in starting the pumps.

The operation of the system was as follows: When a fire was discovered at any particular point the valve controlling that floor and section was opened. The water issued from the perforations in the pipe, flooding the entire floor. If the fire spread to another floor the valve for that floor could be opened, although the water supply was not always sufficient to supply many floors at once.

Defects. A very undesirable feature of a system of this kind was the fact that the water was not concentrated where needed but would wet down the whole floor irrespective of the extent of the fire. This not only caused a heavy water damage in locations where no fire existed but it wasted the water so there was often not enough available at the seat of the fire.

Another feature was the possible clogging of the perforations by rust, paint and sediment. Pipe scale is very apt to form on the inside of wrought-iron pipe, which washed along by the current of water may readily clog any holes as small as these. Such a system could not ordinarily be tested on account of the heavy water damage that would result. It was therefore impossible to determine accurately whether or not the orifices were in a condition to properly discharge water. This feature did not apparently cause much trouble in practice and

was improved in some of the later equipments by drilling the holes larger than the size desired and inserting brass bushings with orifices of the proper size. This tended to prevent corrosion at the outlets and made them less liable to be clogged by paint.

Trouble occasionally occurred from a perforated pipe valve being opened, through error or malice, thus causing great water damage. Then again the valves sometimes leaked, thus allowing the water to fill the pipes gradually and cause damage either by wetting down the building or by freezing and breaking the pipes. This trouble was overcome in many systems by putting a small pet cock in the pipe just above the controlling valve and keeping it open. This allowed the leakage from the valve to waste away at a safe point and yet did not allow too much water to be lost when the system was put into operation.

Perhaps the most unsatisfactory feature of these systems as compared with automatic sprinkler systems was the fact that they were not automatic in action. In many of the fires that occurred in mills so equipped, the valves were either forgotten or were not opened soon enough so that the equipment failed to hold the fire.

In rooms where corrosive vapors were present, Mr. Wm. B. Whiting used brass rosettes or rose sprinklers attached to the pipes instead of perforations in the pipe itself. These were placed about 10 feet apart, in much the same way as in modern automatic sprinkler systems. The rosettes consisted of perforated brass caps similar to watering-pot nozzles but with somewhat larger holes. A cap without perforations fitted loosely over the rosette thus protecting it from dust and corrosion. When the water was turned on, the pressure forced off the outer cap and the water was distributed through the holes in the rosette.

Perforated pipe systems in spite of their many defects

were quite extensively used from 1852 until about 1885 especially in the New England cotton mills insured in the Factory Mutuals Insurance Companies. They were a considerable factor in fire protection until about 1875, and while they have practically disappeared from mill property they are still used to some extent in New York City. Though in many cases they failed to control the fire, they were at times quite successful. A brief description of a few fires, taken from the valuable book compiled by Mr. E. V. French in commemoration of the fiftieth anniversary of the Arkwright Mutual Fire Insurance Company, will give an idea of the practical value of the device.

Fire Record. In 1885 a large fire occurred in the plant of the Plymouth Cordage Company, Plymouth, Mass. Mill No. 1 was equipped with perforated pipe sprinklers and these were successfully used, assisting greatly in saving the mill. The fire started in the picker house, which was just being equipped with automatic sprinklers, and burned this, together with Mill No. 3, which was so equipped.

A fire in the Cocheco Mfg. Co., Dover, N. H., in 1887, started in a cloth drier and spread so rapidly that the employees had barely time to get out. There were perforated pipes in the attic only. These were apparently of some value although the fire was finally extinguished by hose streams. The loss was about \$170,000.

At a fire in the Border City Mill in Fall River in 1877, the perforated pipe system was turned on but no water was delivered. It was afterwards found that there was another valve in the pipe back of the controlling valve and that this was closed. This was a good example of the need of carefully laying out such a system with as few valves as possible and of having all valves up to the controlling valve kept open at all times. The loss was \$398,000.

Another fire occurred in the Flint Mill, Fall River, in 1882, starting in the engine room and spreading rapidly through beltways to all floors. The perforated pipes covering the three upper floors were put into use but failed to hold the fire as the large number of floor equipments used at the same time overtaxed the water supply. The mill was destroyed with a loss of about \$569,000.

At a fire in the Sagamore Mfg. Co., Fall River, in 1884, the perforated pipe system was ineffective as the fire started in the basement and quickly spread to the tower where the valves were located so that they could not be opened. A similar case occurred at the Dunnell Mfg. Co., Pawtucket, in 1890.

CHAPTER II

EARLY AUTOMATIC SPRINKLERS AND SYSTEMS

An automatic sprinkler may be defined as a device that when heated to a predetermined point will automatically release and distribute a stream of water. In all modern sprinkler heads this releasing is accomplished by the melting of low-fusing solder which is used in the construction of the device. In some of the older types of heads the releasing was accomplished in other ways, such as by the burning of a cord, the explosion of gunpowder, the expansion of a volatile liquid in a closed receptacle or the expansion of wax. None of these devices however, except those depending upon the melting of solder, have been of any importance in a commercial sense. While therefore the main principle underlying all successful automatic sprinklers has been essentially the same, the details of construction have varied so widely that one can hardly recognize any resemblance between some of the types.

The time spent and the ingenuity displayed in the invention of sprinkler heads has been prodigious. The patent records show that over 450 patents have been taken out in the United States since 1872, and there have probably been a great many more invented that were never patented. Yet out of this vast array there are today on the approved list of the National Board of Fire Underwriters only 11 heads and of these but 5 or 6 are being extensively used. There are a large number that have been quite generally and successfully used in years past but that have been superseded by improved types and gradually eliminated from use.

AUTOMATIC SYSTEMS

Godfrey. The first automatic fire extinguisher of which we have any record was patented in England in 1723 by Ambrose Godfrey, a celebrated chemist. It consisted of a cask of fire-extinguishing liquid containing a pewter chamber of gunpowder. This was connected with a system of fuses which were ignited, exploding the gunpowder and scattering the solution. In the quaint old patent record the inventor says, "the said vessells so filled and prepared . . . to be made use of by firing the said fuse and then flinging the said vessell into the place where the fire is broke out, which upon the explosion of the gunpowder, blasts out all the flame, and the water or other ingredients which were in the vessell are forcibly driven by the gunpowder against the parts that were on fire, and do damp and suffocate the same so effectually that any man may safely enter the place, and with the proper implements may totally extinguish the remaining fire." This device was probably used to a limited extent, as Bradley's Weekly Messenger for November 7, 1729, refers to its efficiency in stopping a fire in London.

Carey. The first automatic device using water through a system of pipes appears to have been invented by John Carey in 1806. The device was for "the extinguishment of fires in gentlemen's apartments and warehouses, etc.," although there seems to be no reason why it could not have been used in more hazardous places. It consisted of a number of rose or perforated sprinklers connected to pipes supplied with water from an elevated tank. There was a valve in the main pipe normally closed but connected to a system of cords and weights in such a manner that in case the cord was burned the valve would be opened by a counterweight. This was a very crude and impractical device, for the stretching

of the cord would probably have caused the valve to leak, unless, as was quite likely to be the case, the valve became stuck in place so that it would neither leak nor open.

Congreve. In 1809 Sir William Congreve, a hydraulic engineer and Member of Parliament, further developed this idea and patented a sprinkler system consisting of rose sprinklers with combustible cords leading to valves in a place of "outside security and arrangements for a further supply of water by water mains or hose connections to fire engines." In 1812 he substituted for burning cords, a cement fusible at 110 degrees or less. The patent described an automatic sprinkler as "an apparatus for extinguishing fires which shall be called into action by the fire itself at its first breaking out and which shall be brought to bear upon the precise part where the flames exist." Apparently the mechanical details were not worked out in a way which would realize this much to be desired result. This patent included an alarm attachment operated by the dropping of a weight.

Smith. Other systems operating upon the same general principle were patented in England in 1855 by James Smith who employed burning cords or gutta percha as a releasing agent. He also stated that "wire fusible at a low temperature or lime chemically prepared to render it easily ignitable may be employed for the same purpose."

In 1861 Lewis Roughton invented a system which used fusible metal; and in 1863 Roger Dawson used perforated pipes with rose or fan-tail outlets.

Macbay. In 1852 William Macbay patented a device which more closely resembled the automatic sprinkler. It consisted of a system of piping having outlets closed by caps of fusible metal, gutta percha or other substances that would melt at a low temperature.

Pratt. The first patent upon an automatic sprinkler system in this country was apparently the one taken out in 1872 by Philip W. Pratt of Abington, Mass. This device consisted of two revolving hollow arms containing perforations. These arms were attached to a pipe containing water under pressure and there was a valve just above the connection ordinarily kept closed. There was a system of cords and fuses attached to the valve in such a way that when any fuse melted the valve was opened.

Souther. In 1872 John Souther of Boston advocated an automatic fire extinguisher consisting of perforated brass steam pipes.

Steam was turned on automatically by the expansion of the pipe or by the burning of cords. A steam whistle was sounded at the same time.

Meehan. In April, 1873, J. C. Meehan of Springfield, Mass., patented an automatic steam sprinkler operated by fuses running to a small cylinder of gunpowder. When this exploded a valve was opened.

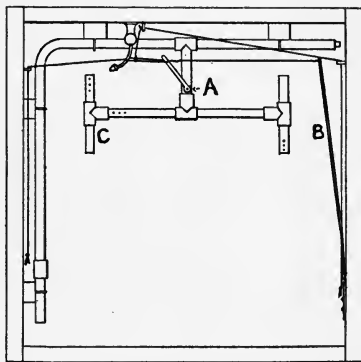

PRATT SPRINKLER SYSTEM.
A, valve. B, cord. C, distributor.

AUTOMATIC SPRINKLER HEADS

Harrison. The first automatic sprinkler head, as the term is used today, was undoubtedly invented by Major A. Stewart Harrison of the First Engineer London Volunteers in 1864. While this device was never patented and was never apparently put upon the market, it not only

showed a very marked advance in the art but was actually superior to the devices that followed it for several years. The head consisted of a hollow brass casting shaped like a flattened sphere with an internal diameter of 3 inches. This contained a large number of counter-sunk holes $\frac{1}{8}$ inch in diameter, located $\frac{1}{8}$ to $\frac{3}{4}$ inch apart.

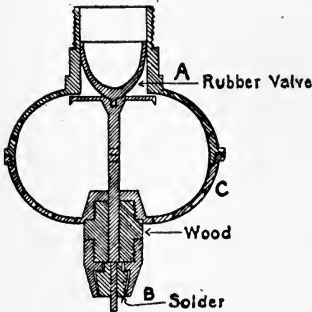

HARRISON SPRINKLER.
(Section.)

At the upper end, the head contracted into a cylinder 1 inch in diameter threaded on the outside so that it could be screwed into a pipe. Inside of this was a valve in the form of a cup-shaped piece of soft rubber which when closed held back the water. The inside of the head at this point was tinned to prevent the rubber from sticking to the brass. The valve being of

rubber and cup-shaped, the water tended to make the joint tighter as the pressure increased. The valve was held in place by a spindle which extended down through the head and through a wooden projection on the under side, to a shoulder at the lower extremity. Here it was held by low-fusing solder under compression. The wooden projection was put on, in order to insulate the solder joint from the brass casting and make the head more sensitive to heat. When the solder fused, the spindle and valve were pushed down by the water pressure and the water was discharged through the perforations.

The particular features in which this head surpassed many that followed it were as follows:

1. A cup-shaped rubber valve that tended to tighten under pressure.

2. A solder joint insulated from the brass casting and from the piping by a good non-conducting material.

3. A valve that had to slide a short distance before any water could be discharged, thus tending to prevent a small stream of water from being discharged before the solder joint had fully parted and chilling or "freezing" the solder so that the head would not open fully.

4. Low-fusing solder under compression rather than tension or shearing strain.

This last point is important from the fact that sprinkler solder melting at a low temperature is subject to cold flow and is not well adapted to withstand, for a long continued period, either heavy tension or shearing strains.

The only serious defects in this remarkable sprinkler were the distribution, which is never satisfactory from a rose or perforated head; the possibility of the holes becoming clogged with pipe scale and sediment; and the soft rubber valve which would only last a few years before becoming hard and brittle. Major Harrison planned to overcome the last trouble by replacing the valves every two or three years.

It was planned to install these heads in much the same way that sprinklers are installed today, spacing them 6 to 10 feet apart according to the combustibility of the contents of room to be protected, and attaching them to the under side of pipes fed by an elevated tank. The inventor also planned an alarm valve in the system actuated by the flow of water when a head operated.

The Harrison head was of the so-called "sensitive" type, as distinguished from the "sealed" or water-joint sprinkler. That is, the solder joint was not in contact with the water in the pipes as was the case in most of the early sprinklers. In the "sealed" type the water in the pipes and the piping nearby has to be heated nearly to the melting point of the solder before the head

can open. This makes them much slower in operation than those of the sensitive type.

Major Harrison's sprinkler was far in advance of its time and it is surprising that it was not imitated more closely by other sprinkler inventors who followed him.

Parmelee. To Mr. Henry S. Parmelee of New Haven, Conn., belongs the credit of inventing the first automatic sprinkler head to be used extensively in practice. It is said that Mr. Parmelee objected to the high rates of insurance charged for his piano factory after the Chicago and Boston conflagrations and that he determined to find some form of protection that would warrant a reduction in rate.

His first idea was a sprinkler depending upon the burning of a cord. This, however, was apparently given up after a conference with Mr. Foskett of Messrs. Foskett, Bishop & Co., New Haven. In the words of Mr. Rounds, Secretary of the Company:

“ Mr. Henry Parmelee visited the shop one morning and exhibited his sprinkler, which contained a spring, to Mr. Foskett. Mr. Foskett . . . told him that his idea of having a releasing device, consisting of a jute or tow string, made it necessary for a flame to be present, and in his opinion an automatic sprinkler should be operated by heat as well as flame, and suggested to him that if he would wait a few minutes he would make him a sprinkler and, with his own hands, turned a cap and attached it to a rose head by means of fusible solder.”

Mr. Parmelee took out his first patent in August, 1874. This covered a device which consisted of a perforated head containing a valve which was held closed against water pressure by a heavy spring. This spring was held in place by two eyes made of low-fusing material. These eyes were protected from water thrown from the other sprinklers by a hood. The device was greatly complicated by an auxiliary valve in the main supply

pipe which shut off the water supply from the head so that when it first opened it was fed only by a small

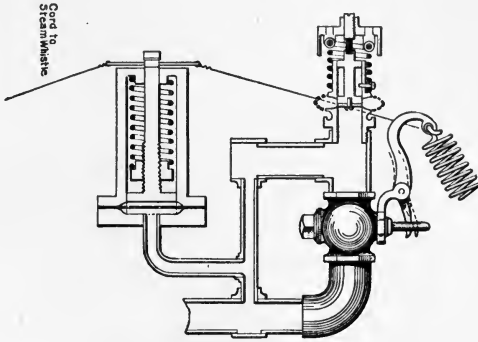

PARMELEE "A" SPRINKLER.

auxiliary pipe. This valve was then automatically opened by the dropping of a piston which was ordinarily held up by the water pressure in the small pipe.

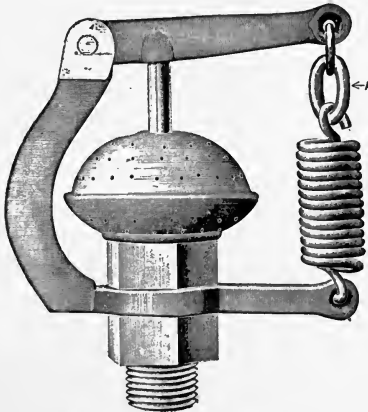

PARMELEE SPRINKLER 1.
A, fusible link.

This sprinkler was of the sensitive or non-water-joint type and was so far as known never used in practice.

The first sprinkler which had actual use in his factory was of radically different design. It consisted of a perforated distributor and a valve, the valve being held in place by a spindle which rested against a lever. One end of the lever was pivoted and the other was attached to the casting with a heavy spring and fusible link.



PARMELEE SPRINKLER 2.
E, distributor. B, fusible washer.

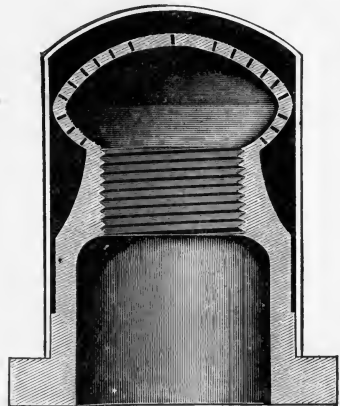

PARMELEE 3.
(Section.)

This design was changed a little later so that the valve was held in place with a wood strut bearing at the upper end against a fusible washer. In 1875 an entirely new type was developed in which a brass cap was soldered over a distributor.

This was one of the simplest sprinklers ever made but was not as sensitive as the previous type because water rested against the inside of the solder joint. This head was designed to screw onto a nipple and was threaded on the inside.

In 1878 the sprinkler was further modified by substituting a rotating slotted turbine for the perforated

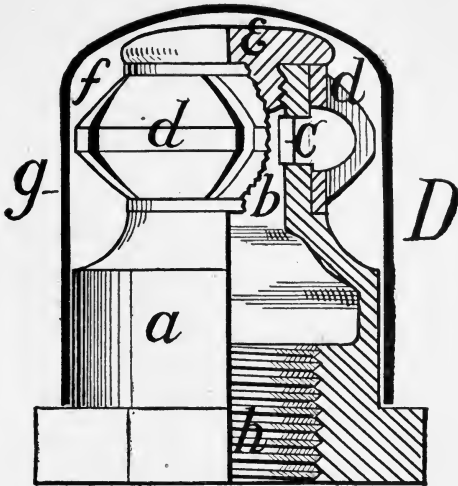

PARMELEE 4.

Fig. 1.

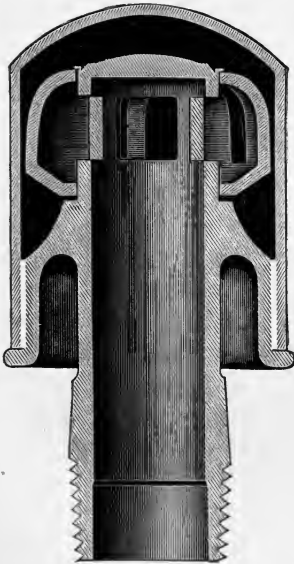

ACTUAL SIZE.

Fig. 2.

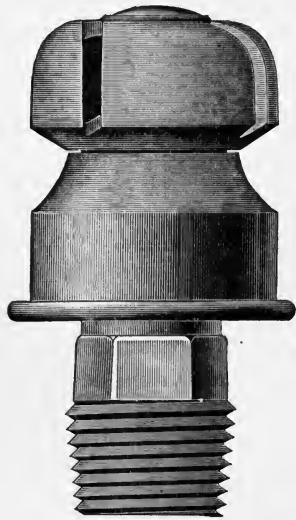

ACTUAL SIZE.

PARMELEE 5.

distributor, thus improving the distribution and giving less chance for clogging by sediment. The same year the head was redesigned by Mr. Grinnell and made more sensitive by hollowing out the base so that much less of the solder joint was in contact with the water in the pipes. It was also threaded on the outside to fit a $\frac{1}{2}$ -inch pipe fitting.

These heads were screwed into the upper side of pipes suspended from the ceiling and spaced about 10 feet apart in each direction. When the head and the piping became heated to the fusing point of the solder (about 160° Fahr.) the pressure would force the cap off from the head and water would be distributed by the revolving turbine.

The method of piping originated by Mr. Parmelee and used for many years in his systems was the so-called "tree" system. The main feed pipes were placed about 20 feet apart and the branch lines were of $\frac{3}{4}$ -inch pipe 5 feet long spaced about 10 feet apart on the feed pipe. This brought the heads about 10 feet apart in each direction. This plan was developed so that each sprinkler would be on a dead end and would not be cooled by water flowing past it in case of fire. In mill construction the feed pipes usually ran across the timbers and the branch lines ran along the center of each bay. The feed pipe was enlarged where the branch lines connected so as to give enough capacity to feed practically all the heads on a floor at once.

Instead of a riser for each floor, as in the perforated pipe systems, one riser was sufficient for all floors and it was large enough to feed the greatest number of heads on any one floor. This was done on the theory that only one floor would be on fire at a time and this same principle is in use today.

The Parmelee system also contemplated an alarm valve which would operate a bell or a whistle in case one

or more sprinklers opened. This consisted of a flapper check valve placed in the main riser near its base. A lever connected with the hinged end of the check extended through a stuffing box and was connected by a wire to a steam whistle or to a mechanical gong. When the check valve was lifted by the flowage of water the steam whistle or the gong was put into operation.

This system was first installed by the piping firm of Foskett, Bishop & Co., of New Haven, Conn. The first regular installation, outside of an experimental one in the plant of the Parmelee Piano Works, was in the risk of M. Seward & Son, New Haven, Conn. Later Mr. Parmelee made arrangements with the Providence Steam & Gas Pipe Company for installing this system, and this company continued to install these heads until about 1882 when Mr. Frederick Grinnell invented an improved type of sprinkler which bears his name.

It is said that some 200,000 of these Parmelee heads were installed, mostly in mills located in New England. The Parmelee catalogue for 1881 gives a list of 214 plants equipped with the device. Of these 140 were in New England, 17 in New York, 14 in Pennsylvania and the rest scattered through the southern states and Canada. This catalogue also gives a list of 19 fires successfully controlled by these heads between 1877 and 1881.

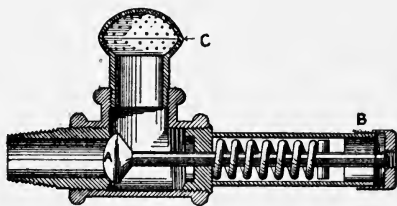

BROWN AND FOSKETT SPRINKLER.
A, valve disc. B, releasing device.
C, distributor.

Brown and Foskett. J. R. Brown and Wm. A. Foskett of New Haven, Conn., took out a patent in August, 1875, for a sprinkler of the sensitive type. It was an

22 AUTOMATIC SPRINKLER PROTECTION

elbow head with a valve in the horizontal pipe to which the rose sprinkler pointing up was attached. The valve was held closed by a piston extending through packing and released by the fusing of solder. There was also a spring to assist opening the valve when the water pressure was light.

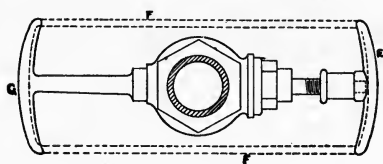
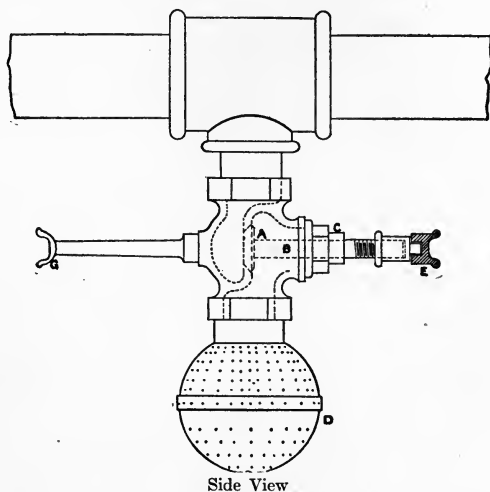

Top View
CONANT SPRINKLER.

Conant. In the same month Hezekiah Conant of Pawtucket, R. I., patented a crude and cumbersome device consisting of a globe valve *A*, held closed against the water pressure in the pipe. The stem *B* of the valve extended through a stuffing box *C* for some dis-

tance, terminating in a short cross arm *E*. It was held in place by light cords or cotton skeins *F* wound around the cross arm and a corresponding projection *G* on the other side of the head. When this cord burned the water pressure opened the valve and water was discharged through a spherical distributor *D* filled with holes.

In a later type a manual attachment in the form of a knife blade was added. This blade was attached to a pivoted arm from which hung a cord that could be reached from the floor. When it was desired to open the head by hand the cord was pulled and the knife blade was drawn across the cord, cutting it and releasing the valve.

This type of head was installed in the plant of the Conant Thread Company at Pawtucket, R. I., but probably nowhere else. It was one of the largest sprinklers ever put on the market and weighed 2 pounds 15 ounces. Like the majority of the earlier heads its most undesirable feature was the possibility of sticking at the valve. One of these heads was taken apart about 25 years after it was made and the valve was found stuck so hard that it was very difficult to loosen it. No head having the valve spindle passing through a stuffing box can be depended upon to work properly for many years.

Buell. Mr. Charles E. Buell invented a sprinkler that was made in New Haven, Conn., in 1873. A few of these were installed in the shop of James Buel, Woburn, Mass., in September, 1881. This was probably the first head of the sensitive type to be put into practical use. It was also said to be the first head to use the modern principle of distributing water coming through an open outlet by means of a splash plate or deflector. To quote Mr. Buell: "The sprinkler with the spring strap, like sugar tongs, was the first of its class and was made first in New Haven, Conn., in 1873. It comprises a valve

closing the otherwise open outlet in a manner to be discharged without any friction. The spring strap is, like the sugar tongs, a lever of the third class and by leverage removes strain from the film of solder that in turn is removed from the chill of the water. The spring

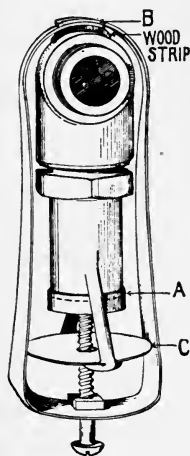

BUELL SPRINKLER.

- A, valve cap.
- B, solder joint.
- C, deflector.

of the strap gives a thrust to the releasing parts and with the exception of not being as conveniently put in place, this form will do all that modern sprinklers will do." This, says Mr. Buell, was the first of the class of open outlet sprinklers and the first to deliver a stream of water against a deflector secured in front of the outlet.

This sprinkler was of the elbow type, that is, it was designed to screw into the side of a pipe, and the water turning a right angle was distributed on a splash plate at the lower side. The outlet was closed by a round metal cap containing a lead washer. This was held against the outlet by a screw passing through a small hole in the deflector and fastened to the sugar-tong spring.

This spring was of thin brass and extended up over the body of the sprinkler. Here the two ends were soldered together with low-fusing solder but the joint was insulated from the body of the head by a thin strip of wood. The deflector was a thin brass plate about $1\frac{1}{4}$ inches in diameter, held in front of the orifice by two arms extending out from the lower side of the head.

This head, while crude in design, contained, like the Harrison head, many advanced principles and theoretically at least was superior to many heads that followed it.

Barnes. Mr. Charles Barnes of Cincinnati was one of the group of early inventors in this field. He patented

his first sprinkler head in 1879. This was of the sensitive type and somewhat resembled the Harrison sprinkler although it lacked many of the good features of the latter. It consisted of a hollow brass casting perforated with small holes and with the valve located inside at the upper end. The valve stem extended down through the head and was threaded through a nut of low-fusing solder attached to the lower side of the casting.

In 1881 he improved the head by discarding the fusible nut and substituting a horizontal lever *D* for holding the stem in place. One end of the lever was hinged and the other was held in place by a latch fastened by low-fusing solder *B*. The solder joint was well placed to receive the heat quickly, but the head was weak in the matter of distribution and in the construction of the valve.

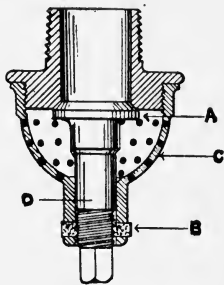

BARNES A.
(Section.)

- A, valve.
- B, fusible nut.
- C, distributor.
- D, stem.

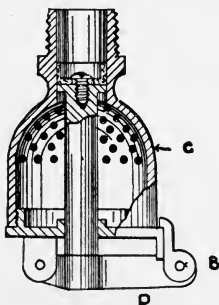

BARNES 1.
(Section.)

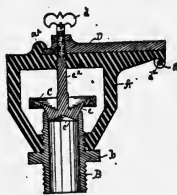

BARNES 2.
(Section.)

In 1885 Mr. Barnes invented a valve sprinkler with a deflector. In this head, known as Barnes No. 2, the deflector and valve, which were in one piece, consisted

of a small brass disc with a raised toothed edge and with a few small perforations near the outer edge. This was held against the orifice by a long lever hinged at one end and connected to an arm projecting from the casting, by a fusible link. The valve could be set up tight against the orifice by a set screw. The brass against brass valve was not well adapted to withstand the tendency to leak. Otherwise, except for its bulk, this was a well-designed head.

Bishop. Mr. John W. Bishop of New Haven, who was quite prominent in the early development of sprinklers, took out his first patent for such a device in 1879.

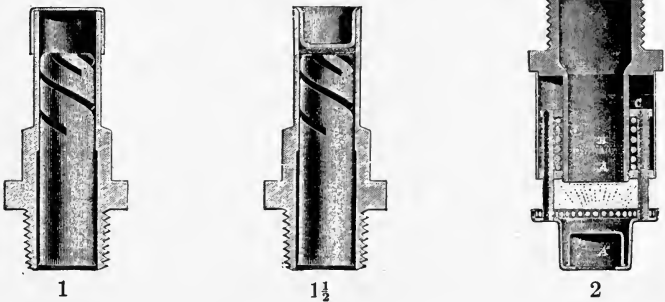

BISHOP SPRINKLERS. (Section.)

This was a sealed head of complicated design containing a balanced sliding valve around which was a small bypass. This was apparently never used, but in 1883 he patented an improved head, generally known as the Bishop No. 1 head, which attained considerable prominence. This was probably the first head to use the principle of the interior or sleeve distributor. It consisted of a brass pipe-shaped casting threaded at one end for a half-inch fitting and with a thin brass cap soldered over the other end. Inside was a sleeve containing helical slots. When the cap was released, this sleeve was pushed forward a short distance from the

orifice by the water pressure and held at that point by an interior shoulder. The water passed through the sleeve and was distributed from the helical slots.

Later this head was rendered more sensitive by making the releasing device in the form of a thimble soldered to the inside of the orifice. A washer of insulating material was placed between the thimble and the sleeve. This kept the water away from the soldered joint and allowed both sides of the joint to be exposed to the heated air.

In 1884 this head was radically changed by doing away with the interior sleeve and substituting a deflector with perforated edge. This deflector was attached to the head by two bars running to a collar surrounding the head. There was a light spring inserted under the collar to hold the deflector close to the orifice. The pressure of the water pushed the deflector a short distance away during the time that the head was in operation. In this head, known as the Bishop No. 2, the screw thread was made for a $\frac{3}{4}$ -inch fitting but the orifice was bushed down to $\frac{1}{2}$ inch.

Burritt. A. M. Burritt of Waterbury, Conn., invented several sprinklers, the first of which was patented in 1881. This was a rose sprinkler of the sealed or water-joint type. The orifice pointed inward from a hollow casting and was closed by a metal thimble soldered in place. The head was spherical in shape with perforations covering about half of the sphere. It was threaded on the inside for a pipe connection.

The so-called Burritt No. 1 was a slight modification of this and had the thread on the outside and a loose fitting cap which covered the rose distributor to keep out dust and dirt. In 1882 the Burritt No. 2, a slight modification of No. 1, was used, but in 1883 an entirely new type, known as No. 3, was adopted. This was of the sensitive type and consisted of a rectangular-shaped

casting with a slotted deflector surrounding the orifice. The valve was a round metal disc with a stem extending to the lower part of the frame where it was held by a

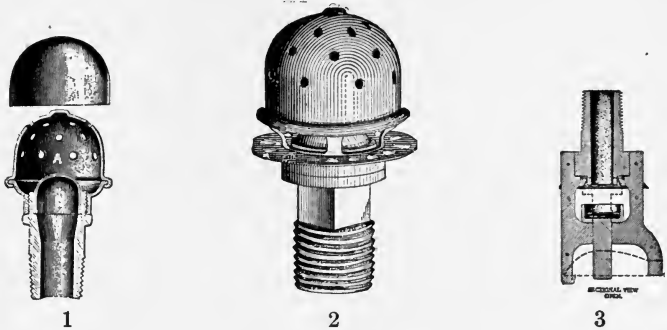

BURRITT SPRINKLERS.

lever, one end of which was hooked to the main casting, and the other soldered to a projection on the frame. The water was distributed by striking the flat circular valve seat and being thrown back onto the deflector.

Whiting. Mr. F. M. Whiting of Chelsea patented a sprinkler in 1881, which in the original and modified form was used to some extent in New England. The

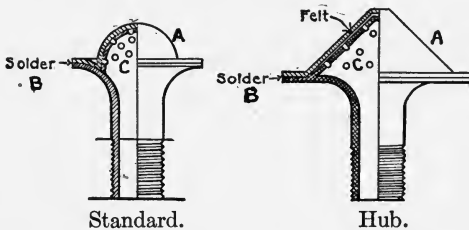

WHITING SPRINKLER.

original head, sometimes known as the Standard, was fan-shaped in cross section with a curved perforated distributor inserted near the large end. Over this was soldered a cap, of a similar shape, turned up at the edges

to fit the large end of the head. This solder joint, like that in the last type of Parmelee head, was exposed to the heated air on two sides and was thus more sensitive than many heads of this type. This head was simple in construction but the distribution was limited to a comparatively small angle.

The modified form known as the Hub was very similar to the first type except that the distributor and cap were conical in shape and there was a layer of felt between the two. This tended to keep the water away from the solder joint and make the head more sensitive. In both these heads the solder joint, unlike that in most of the early heads, was under tension stress only.

Granger. Mr. A. M. Granger of Boston, afterwards agent for the General Fire Extinguisher Company at Buffalo, N. Y., invented a sprinkler in 1881 of the elbow type. The valve stem was capped with a disc of fusible metal against which rested a stiff spring holding the valve closed. When the fusible disc melted the water pressure opened the valve. The water was distributed through a reactionary turbine located on the top side of the head.

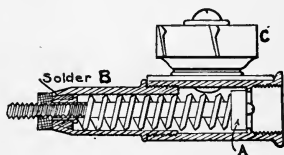

GRANGER SPRINKLER.

A, valve. B, solder joint.
C, turbine.

Brown. Mr. J. R. Brown of Bridgeport, Conn., formerly with the P. S. & G. P. Co., and who invented several early heads in conjunction with W. A. Foskett, patented a head under his own name in 1881. This was a valve sprinkler in which the valve was held closed by a cap soldered over the lower end. The valve stem was hollow; the water entering this hollow space through slots at the top was distributed through holes or slots in the lower end when the head opened.

In 1883 this head was slightly changed and this

pattern, known as Brown No. 1, was quite extensively used. In this head the valve was conical in shape and seated against a ring of softer metal which was wedged by the water pressure between the interior of the head and the valve, thus making a tight joint. The valve stem extended down through the head and was attached to a solid deflector with grooves on the upper surface.

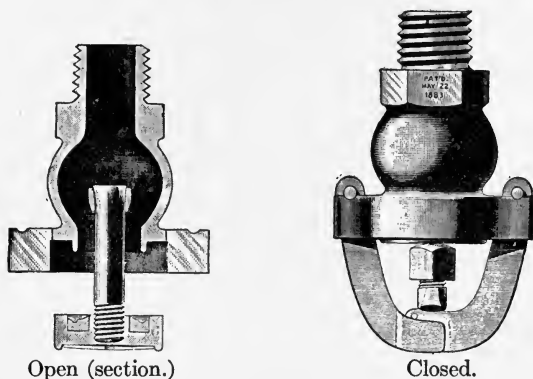

BROWN SPRINKLER NO. 2.

The deflector was beveled on the edge and fitted tightly into a lower side of the head which was beveled in the same way. This deflector, soldered in place, held the valve closed. When the solder fused, the deflector dropped about $\frac{3}{4}$ inch and was then held by an enlargement in the stem wedging into a hole in a bridge supported in an enlargement of the head.

About the same time the Brown No. 2 head was patented. In this head the valve and deflector were in one piece, the valve seat being at the lower side of the head. The deflector was held in place by two curved levers hinged at the upper end and soldered together at the lower ends. A short strut, which could be adjusted to take up any play, extended from the deflector to the levers. The deflector was held from dropping too far

by a spindle as in the former head. The solder joint was well placed in this head so as to make it quite sensitive to heat. Both of these heads were assigned to the Automatic Fire Alarm and Extinguisher Co. of New York.

Harris. A. C. Harris of Chelsea, Mass., patented a sprinkler in 1881 of the sealed or water-joint type. This was quite similar to the Whiting head except in the manner of soldering the cap over the outlet. The head was fan-shaped in section with a curved perforated rosette for distributing the water. A thin brass cap covered the rosette extending slightly over the edge where it was soldered with low-fusing solder. In 1882 Mr. Harris took out a patent on a valve or sensitive type head. The valve stem extended through the head and was soldered to two curved springs projecting from the body of the head.

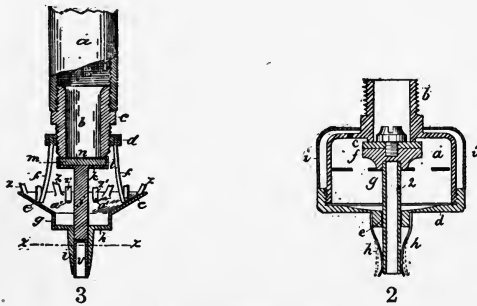

HARRIS SPRINKLERS.
(Section.)

Neither of these heads were used in practice so far as is known but a third type patented in 1883 did have considerable use. In this head a six-sided deflector was attached to sprinkler by arms extending downward from a collar. In the center of the deflector was a hole through which the valve stem passed. The orifice, which extended down nearly to the deflector, was closed

by a valve with a stem extending down through a hollow tube at the bottom of the head. A thimble was soldered into the end of the tube to hold the valve in place.

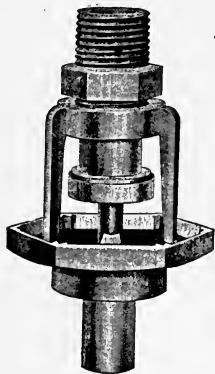

HARRIS 3.

The principal defect in this head, in common with all heads having this form of release, was the tendency of the thimble to bind in the tube and not slide out readily when the solder fused. In case the tube was slightly bent or indented it would almost surely cause the thimble to stick.

Kane. John and William Kane were very prominent in the sprinkler business in Philadelphia for a number of years. They, separately and together, invented many heads. A large number of these heads were installed especially in Philadelphia and near-by sections. The Wm. Kane Fire Extinguisher Co. installed the early heads and the Universal Automatic Fire Extinguisher Co. installed some of the later types.

The first patent of John Kane was taken out in 1881 and was one of the most curious heads ever invented. It was a valve sprinkler with a long stem extending down below the casting.

The distributor was in the form of four curved arms which rotated when the water passed through them.

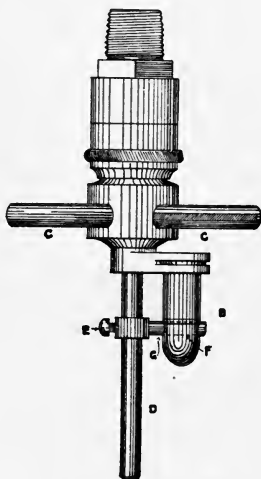

KANE CARTRIDGE
SPRINKLER.

B, cartridge. C, distributor.
D, valve stem.

The most extraordinary feature, however, was the releasing device. An ordinary ball cartridge was clamped to the head with the ball end pointing down. A hole was bored in the ball end and through this hole a short rod projected. This rod was fastened to the stem of the valve by means of a set screw, thus holding the valve in place. The explosion of the cartridge was necessary to open the head and if anyone happened to be under the head at the time he might have suffered from a bullet wound. The sprinkler was never used so far as known.

In 1882 John and William Kane patented a sprinkler in which the valve was held in place by a spring passing over the end of the head. This spring was hooked to a projection at one side and soldered to a projection at the other side. This head slightly modified is generally known as the William Kane head No. 1. The head known as the William Kane Eclipse or No. 2 was apparently patented by John Kane in 1886, although it is said to have been in use as early as 1882.

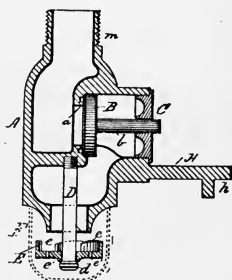

KANE 2. (Section.)

It was a large cumbersome head containing a globe valve with a spindle held in place by a complicated system of levers, one of which was curved and extended a considerable distance beyond the head. Distribution was by means of a small revolving deflector attached to a rod at the lower end. A loose cap fitted over the deflector when the head was closed.

Draper. In 1884 F. H. Prentiss of Boston patented a sprinkler depending in its operation upon the expansion of ether and other volatile materials. The valve opened against the water pressure so that the pressure in the pipes tended to keep the valve closed. The spindle of the valve was attached to one side of a closed

receptacle containing ether and alcohol. This receptacle had corrugated sides and when the volatile contents

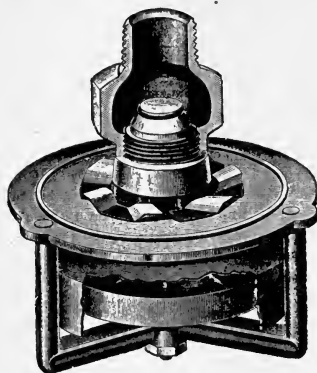

DRAPER.

expanded from heat these sides were forced apart. This motion pushed up the valve, thus opening the sprinkler. The water was distributed from a flat plate, though in the later types a thin corrugated ring was installed to break up the stream. The closed receptacle was protected from the possibility of getting wet by a metal hood. In the earlier patterns of this head there was

no device for locking the valve open and it was apt to close too soon from the cooling of the air around it. Later a latch was provided to hold the valve up after it had once opened.

This head was usually known as the Draper head and, though ingenious, had but little use in this country. It was submitted for approval in England under the name Draper-Hetherington, but G. H. Bailey, who made tests upon a number of heads in 1889, reported that acceptance should be refused as it failed to fulfill the requirements for an efficient sprinkler. In these tests the head opened as low as 110° F., although it was supposed to open at 140° F. This was, of course, too low an operating point to be safe in warm weather. In several of the sprinklers tested, leakage of ether occurred when the sealed receptacle was greatly warmed, in one case to such an extent that the vapors ignited. The heads submitted apparently had no locking device as they closed again in two or three minutes. The valve so obstructed the outlet that the amount of water dis-

charged was much less than would come from a $\frac{1}{2}$ -inch free outlet.

The principal objection to such a head is the danger of the volatile ether leaking out owing to corrosion, age or slight defects, thus making the head useless.

Walworth. In 1883 C. C. Walworth and O. B. Hall of Boston patented the first type of Walworth sprinkler. This head was modified and improved at intervals until 1899, but the same characteristics were carried through all the modifications. The head was installed by the Walworth Manufacturing Company of Boston until 1900 when the business was sold out to the Manufacturers Automatic Sprinkler Company of Syracuse, N. Y. This head was extensively used and was especially popular in the New England field. One reason for this popularity was the fact that, in all but the original type, the head was so constructed that it could be used again after it had operated by simply replacing the old link. This feature, while appealing to the factory owner, was later found to be undesirable from the fact that it led to frequent adjustments in the field. On this account the stresses on the parts, particularly in the soldered link, were of unknown and variable quantity; there were occasional leaks due to too light a stress being applied, as well as sticking at the seat due to too heavy stresses.

The first Walworth head had a $\frac{1}{2}$ -inch orifice closed by a valve disc with a lead seat. This was held in place by a lever which, when in its normal position, was parallel to the frame of the sprinkler and was soldered to it. This was not a very sensitive head, for as the solder joint was not in any way separated from the main casting, it was necessary to heat the entire head before the solder would fuse.

During the same year the head was improved by replacing the soldered arm with a link of fusible solder which fitted over the top of the lever and held it to a

projection on the main casting. This, the so-called solder link or No. 2 model, was found defective in that

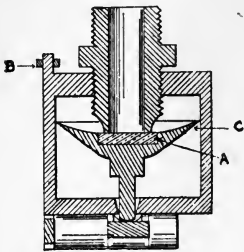

WALWORTH 2.

(Section.)

A, valve disk. B, solder link. C, deflector.

the link stretched under pressure and allowed the head to leak. In order to overcome this difficulty the third type, known as the drop deflector type or 2 A, was put out a little later. In this head the link was made of two U-shaped pieces of brass soldered together with one piece entirely inside the other.

This link was found unsatisfactory because the inner section of the link tended to spread slightly, thus forming a wedge-shaped joint that created too much friction when the two pieces forming the link parted. The link was later changed so that the two pieces were soldered together side by side and tended to separate more freely when the low-fusing solder melted.



WALWORTH LINKS.

In the No. 2 Walworth head the deflector and valve were all one piece and the deflector, guided by the uprights of the main casting, dropped to the bottom of the frame when the head opened. The No. 3 type, dated 1885, was similar except that the deflector was fastened to the frame about half an inch below the orifice and the valve spindle passed through a hole in the center of the deflector.

Mackey. The first Mackey sprinkler, patented in 1885, was the first type of the well-known Manufacturers heads which have been used for many years. This head went through a development of four types under the name Mackey and seven more types under the name of Manufacturers, finally emerging as the Manufacturers type C, which is on the approved list today.

The first type, known as No. 1, was threaded for a $\frac{3}{4}$ -inch outlet but the orifice was bushed down. The valve was cone-shaped with a short spindle extending through the deflector. Two curved levers passing through bosses on the under side of the deflector held the valve in place. They were released by the fusing of a link somewhat similar to that used in the Walworth head except that the two outer ends were longer and extended around part of the end of the other link.



The deflector was about half an inch from the orifice and contained small perforations and a corrugated surface.

Ruthenburg. Another cumbersome head was the Ruthenburg, patented by Marcus Ruthenburg of Cincinnati in 1885. It was, however, simple in construction, consisting of a casting containing an orifice and with a

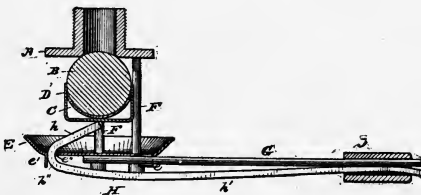

RUTHENBURG. (Section.)

deflector fastened to the frame by bolts. The valve was a rubber sphere and was held in place by a thin lever about 6 inches long. This lever was held to a similar projection by a fusible link. The head was used to considerable extent in the West.

Grinnell. To Mr. Frederick Grinnell of Providence should be given the credit of doing more than any other one man to develop the art of sprinkler protection. His company, the Providence Steam & Gas Pipe Co., was

one of the first to install perforated pipes and sprinklers and the scale of pipe sizes and method of erecting the piping inaugurated by this company was the generally recognized standard for many years. This company originally installed the Parmelee sprinkler and continued to do so until 1882 when the first Grinnell head was invented.

Mr. Grinnell took out a vast number of patents covering perforated pipes, sprinkler heads, deflectors, solder joints and many other details. Under his control the Providence Steam & Gas Pipe Co., afterwards the General Fire Extinguisher Co., became the leading sprinkler company in the country.

In 1880 he patented a sprinkler somewhat resembling the Harrison head in principle, but this was never used so far as known. In 1882 he invented a sprinkler which was a radical departure from anything that had been made up to that time. Instead of a nozzle, he used a plate orifice or, in other words, a thin brass plate or diaphragm, containing a $\frac{5}{16}$ -inch hole, for discharging the water. This diaphragm was inserted in an enlargement of the casting and had a total diameter of a little over an inch. As it was quite thin, a stiff spring plate was inserted just under it so as to insure a strong spring action to the levers and to prevent the diaphragm from collapsing when the sprinkler was not under pressure. The edges of the orifice in the diaphragm were bent over to form a seat ring about $\frac{1}{8}$ inch wide. The valve and deflector were in one piece, the center of the deflector being depressed and filled with a disc of lead to form the valve. The deflector itself had teeth projecting at right angles around the edge to distribute the water. The valve was held in place by a pair of compound levers, the first being held at one end by a notch in the yoke and at the other end by the second lever. The latter was hooked under a notch in the other side of the yoke

and soldered at the extreme lower end by fusible solder reinforced by an L-shaped piece of wire. Perhaps the best feature of this head, and one that was confined to Grinnell heads for many years, was the arrangement of the diaphragm discharge whereby the increase of

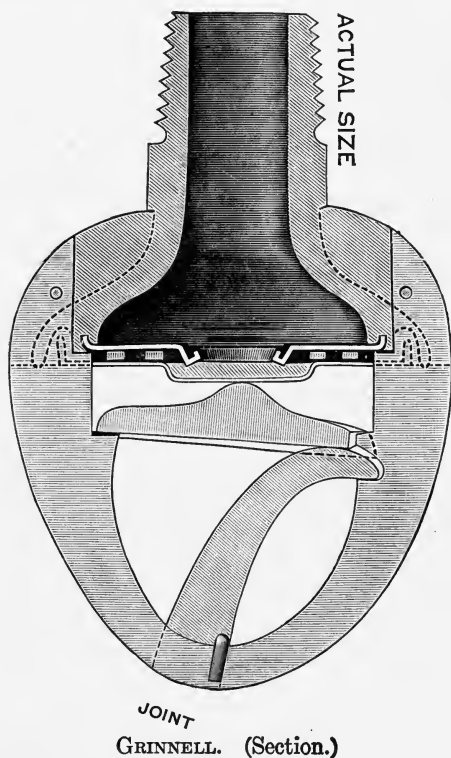

pressure tightened the valve instead of tending to make it leak, as in most heads. This was accomplished by making the area of the diaphragm exposed to the water pressure larger than the area of the valve which was exposed to water pressure. The valve was held rigidly in place by the levers but the diaphragm was flexible.

Thus the pressure of the water being greater on the diaphragm than on the valve (on account of its larger area) the tendency of increasing the pressure was to make the joint tighter.

The first type of Grinnell head was only used a few weeks when a few minor improvements were made and the so-called Grinnell type A head was put upon the market. Three other types were put out at intervals, namely, the type B in 1884, C in 1886 and D in 1888. They were all similar in principal, however, the changes being only in details such as the width of the valve seat ring and the metal used in the valve disc.

The Grinnell head soon became the standard sprinkler of the country and was very extensively used. It is one of the few early heads that after numerous developments and changes is still on the market.

ODD DEVICES

In this first decade of the history of sprinkler protection a number of patents were taken out upon odd devices that were never used in practice but are interesting to note.

Miller. Joseph A. Miller of Providence patented a head in 1878 in which the releasing device was actuated by the expansion of rods and the expansion of oil in a closed receptacle.

Briggs. In 1882 R. Briggs of Brooklyn invented a head in which the melting of the solder was supposed to be accelerated by placing some highly combustible substance like sulphur close to it. ¶

Delmage. C. L. Delmage of Woonsocket, R. I., took out a patent in 1883 for a head, which was covered with a glass ball. There was a small pivoted hammer actuated by a spring so arranged that when a fusible link melted the hammer was released, and striking the glass ball shattered it and released the water.

A similar device was patented by R. L. Cumnock and P. J. Marrs in 1892.

Ashcroft. In 1886 E. H. Ashcroft of Lynn, Mass., patented a head with a very novel form of distribution. The water issued from four small outlets arranged around the head and each stream played onto a bell-shaped deflector fastened just below the outlet.

CHAPTER III

LATER DEVELOPMENTS IN AUTOMATIC SPRINKLERS

TYPES

The first decade of the history of automatic sprinklers may be said to have ended in 1885. It was a period of prolific invention in which many heads of widely different types were thoroughly tested by field experience. The more important of these types were as follows:

1. Heads depending upon the burning of cords.
Example: Conant.
2. Rose heads of the sealed or water-joint type.
Examples: Whiting, Harris and early types of Burritt.
3. Rose sprinklers with valves.
Examples: Harrison, Brown & Foskett, Barnes.
4. Sealed type with turbine or slot distribution.
Examples: Parmelee 5, Bishop.
5. Valve sprinklers with deflectors and operating by the fusing of solder.
Examples: Buell, Grinnell, Burritt 3, Mackey.

The latter type might be divided into several sub-types as follows:

- (a) Those with valve held in place by soldered thimble under direct strain.
Examples: Harris, Bishop 2, Gray.
- (b) Those in which valve is held by levers and a link.
Examples: Bishop, Mackey, Walworth, Ruthenburg.

- (c) Those in which valve is held by levers soldered in place.

Examples: Brown 1, Burritt 3, Grinnell, Kane.

The developments which followed 1885 were more along the lines of perfecting old types rather than creating new ones. For reasons too obvious to dwell upon the types depending upon the burning of cords and those with rose distributors were very soon given up. The use of the turbine and slot distributors was also short lived and was practically limited to the Parmelee and early Bishop heads. The use of the sealed or water-joint types was discarded on account of their lack of sensitiveness. Thus it was that after 1885, there were practically no sprinklers made except those of the last type, namely, valve sprinklers with deflectors. The development after this date consisted largely of improvements in the sub-types under this general heading, although one rather distinct sub-type was created, namely, the valve held closed by a strut composed of several pieces of metal held together by low-fusing solder. Several important inventions were made in the form of valve and in the orifice such as the hollow valve disc, valve discs of glass and porcelain and diaphragm orifices; but the heads in which these were used were all of the same general type. While a few heads of radically different types were patented they were as a rule unsuccessful and had but a short life.

ODD TYPES

Before discussing the further development of the fifth type of sprinkler it might be well to mention briefly three sprinklers of other types that are of interest, namely, the Mascot, Nagle and Shaw.

Mascot, 1881. This was an elbow sprinkler with a valve and a deflector. The valve was located inside

of a hollow casting and was held against its seat by a number of hinged levers which when in the normal position formed a strut. At the upper side of the head there was a small chamber containing a wax which expanded under heat. A piston extended from this chamber to one of the levers which formed the strut. The wax receptacle was so adjusted that when the wax expanded the piston was moved forward and pushed the lever, against which it rested, sufficiently to throw the hinged levers off centre, and thus relieve the pressure on the valve. This allowed the valve to be opened by the water pressure and pushed forward a sufficient distance to allow the water to be discharged from a $\frac{1}{2}$ -inch hole in the side of the hollow casting. The deflector was held in front of this outlet at a distance of about $\frac{1}{2}$ inch from it. The water turned a right angle as it passed through the head so that the sprinkler had to be screwed into the side of the supply pipe in order to have the deflector parallel to the ceiling. There was also

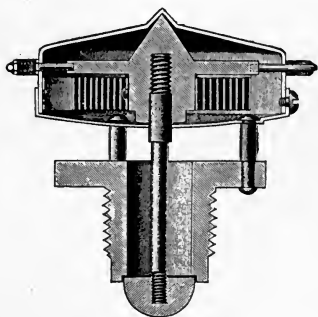

NAGLE.
(Section.)

an alarm attachment. This head though interesting in principle was crude in construction and was of little importance practically.

Nagle 1, 1890. This was a valve sprinkler with a deflector and was operated by the melting of solder. The valve was at the end of the screw fitting and, like the Draper, opened against the water pressure. A

spindle was attached to the inside of the valve and extended into a closed metal cylinder where there was a long steel spring like a clock spring. One end of this spring was attached to a nut into which the spindle of

the valve was threaded; the other end was attached to the inside of the cylindrical casing. Two arms extended from the nut to the outside of the casing and were soldered with low-fusing solder to projecting brackets. When these arms were released by heat the spring uncoiled and the motion it imparted to the nut screwed the spindle forward and threw the valve off its seat. As the valve fitted into a groove and was cemented in place with asphaltum or some similar material the chance of sticking seemed to be great in spite of the strong spring that was supposed to release it.

Shaw, 1901. This was a valve sprinkler with a toothed deflector and a frame of modern design. It operated upon a principle similar to the Mascot, except that the actuating device which caused the parts of the strut to fall apart was a small receptacle containing alcohol or ether instead of an expansive wax. When the alcohol or ether expanded, the side of the thermostatic chamber was pressed outward and this movement threw out a key which allowed the strut to collapse. Like the Draper, this head could readily be made inoperative by corrosion, blows or other means which might allow the leakage of the expansive fluid.

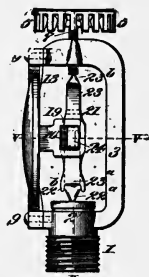

SHAW.

DEVELOPMENT OF THE PRINCIPAL TYPES

Bishop. In 1885 the fourth Bishop sprinkler known as No. 2 $\frac{1}{4}$ was first made. This was a valve sprinkler with a deflector, the valve being held closed by a stem extending to the lower end of the head and held in place by a plug soldered into a collar surrounding the spindle. This head, together with the other five types of Bishop heads, made between 1884 and 1888, was threaded for a $\frac{3}{4}$ -inch fitting. This is also true of the Gray, Harkness

No. 1, the New York & New Haven, and all Mackey heads. The last of these heads was made in 1889 and

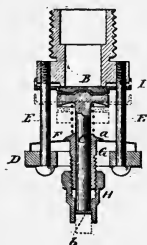

BISHOP 2 $\frac{1}{4}$.
(Section.)

after this the business became standardized to the extent that all heads, with the single exception of the Manufacturers, were made for a half-inch fitting.

The type of Bishop head, known as No. 3, was very similar to the 2 $\frac{1}{4}$ head, the deflector of each sliding on a spindle and being held up by a light spring. When the head operated, the deflector was pushed down on guides a short distance by the water. Two other types of Bishop heads No. 3 $\frac{1}{2}$ and 4 followed in 1887 and 1888. These were quite similar to the previous types except that the valve spindle was held in place by two hinged levers, these being held together by a fusible link.

Brown. In one of these heads, patented in 1884, Mr. Brown used a very novel principle, namely, that of having water pressure on two valves, one at each end of the strut that held the valves closed. To accomplish this, the water passage of the sprinkler was split and ran to two opposing outlets. One outlet was enlarged and covered by a flexible diaphragm which acted as a deflector. The strut which held the valve against the other outlet consisted of a small cylinder soldered into a cup-shaped receptacle. The lower end of the strut rested on the flexible deflector and the water pressure acting on this created a balanced pressure and tended to keep the valve tight. This head was never used so far as known.

Buell. The Buell head known as No. 3, made in 1884, was unique in the method of distribution. The head was in the form of a hollow ring with a small orifice, about $\frac{1}{8}$ inch in diameter at the bottom and a larger orifice, about $\frac{1}{4}$ inch in diameter, at the further or upper

side facing the first one. The size of the two orifices was supposed to be figured so that, allowing for friction loss, each orifice would discharge the same amount of water. The valves which closed these two outlets were apparently in the form of a single strut with the component parts held together with fusible solder. When the strut melted the two streams of water were released and these striking each other distributed the water without the aid of any deflector.

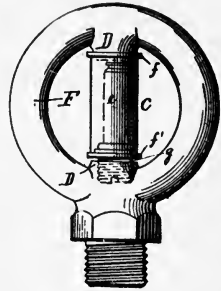

BUELL 3.

The No. 4 head was similar except that it was in the form of a half ring, the water coming only in one direction to each outlet. The orifices were about $\frac{3}{8}$ inch in diameter.

The last two types, No. 5 and No. 6, were similar to each other and contained $\frac{3}{8}$ -inch orifices closed by a valve, the stem of which extended through the deflector.

This was held by a fusible joint consisting of a horizontal plate into which the stem was screwed and two levers with corrugated surfaces soldered together.

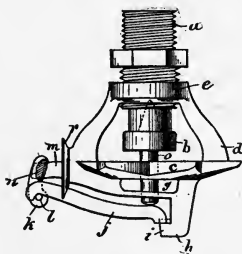

STAR SPRINKLER.

h, valve cap. *j*, *k*, levers.
n, solder joint. *r*, disc to
protect solder joint.

Star. Patented by W. T. Montgomery in 1886. This was a valve sprinkler with a conical valve fitting into a $\frac{1}{2}$ -inch orifice. The stem of the valve was held by two levers, the shorter one being soldered to the frame. The solder joint was protected to some extent from being

wet by a flat disc in the casting. The deflector was star shaped. Mr. Montgomery formed a company and installed these heads for a few years. Later he became Boston Agent of the General Fire Extinguisher Co.

Clapp. Joseph Clapp of Chicago invented a head in 1887 and another in 1890, the latter being quite extensively used. Both were valve sprinklers with fixed deflectors. In the first head the deflector was supported

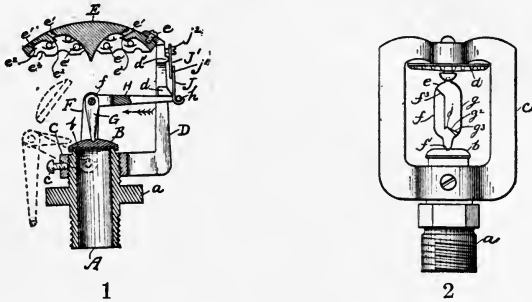

CLAPP SPRINKLERS.

by an arm extending over the orifice. The valve was held in place by a complicated strut consisting of several levers with a fusible link attached to the arm. The second head was of modern design with a strut bearing against a valve disc at one end and the deflector at the other end.

Hill. Patented by John Hill of Columbus, Ga., in 1885. This was a valve sprinkler with an oscillating deflector. The fusible release consisted of two semi-circular plates soldered to a hollow base. The spindle from the valve had a conical-shaped point resting in a hole between the two soldered plates. When the solder melted these plates were pushed to either side allowing the valve to drop.

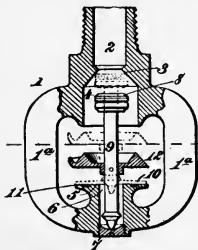

HILL. (Open.)
(Section.)

The conical point dropped into a depression and the deflector was so shaped that the water gave it an oscillating motion about the end of the spindle as a center. The Hill

Company installed a considerable number of equipments but finally sold out to the General Fire Extinguisher Co.

Gray. The Gray head was installed for some years by the Edward Barr Co., of New York, but was sold to the General Fire Extinguisher Co. There were several types of Gray heads but they were quite similar. The releasing device consisted of a thimble soldered to the inside of a hollow tube which constituted the lower end of the head. The defect of this type of construction has already been noted.

This company had a very elaborate dry system for use in unheated buildings. It consisted of an auxiliary system of piping of small size, placed parallel with the main piping and containing small fusible plugs at intervals. Air was pumped into these small pipes and when a plug melted the reduction of the air pressure was made to open a dry valve controlling the sprinkler system.

Hibbard. The first Hibbard sprinkler was invented by Mr. Geo. E. Hibbard of Chicago in 1893. It was an upright sprinkler with conical-shaped deflector. The valve was held in place by two long levers hooked to the frame and extending around the deflector to the top of the head where they were held together by a fusible link of corrugated metal. (See appendix.)

It was installed in the vicinity of Cincinnati. In 1894 the No. 2 head was invented which was of quite different construction. This had a perforated deflector attached to the outside of the frame. A hollow valve cap was held in place by two toggle-joint levers, these being secured by a fusible link.

In 1897 the head was slightly modified by lengthening the levers and using a stronger valve disc which had more spring action. This was known as No. 3. In

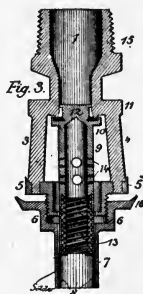

GRAY.
(Section.)

1898 a slight modification was made by arranging the toggle joint to move on pivots. This is called 3A.

In 1901 a head, made by the Niagara Fire Ext. Co., but labeled Hibbard, was installed. In this the toggle-joint levers were straighter and less ornate. The link was of different design, being hollow with a horizontal section in the center.

The Hibbard sprinkler was made by four different concerns, three of these operating simultaneously, so that there are several variations that are rather hard to distinguish from one another. These companies were:

American Fire Extinguisher Co., Chicago.

Mallers, Allen & Frazer, Chicago.

National Fire Extinguisher Co., Kansas City.

Niagara Fire Extinguisher Co., Akron, O.

In 1902 the Niagara Fire Extinguisher Co., secured full control of the head and changed the name to Niagara-Hibbard. Soon after this a new form of link was adopted. In 1903 the general form of the frame was radically changed and the new form was approved in 1904.

The largest number of the Hibbard heads was put out by the two Chicago concerns. Those made at Akron were of a later date and were more reliable than the older ones.

Many Hibbard heads have failed on test during the last few years due principally to the following causes:

1. Levers too near a "dead center."
2. Wedging at fulcrum of levers.
3. Defects in links.
4. Sticking of valve.
5. Sticking of washers, thus cutting down the discharge about 20 per cent.

In 1911 Mr. Hibbard submitted a new head known as the Hibbard I for approval. He formed a new com-

pany under the name of Geo E. Hibbard & Co. This head was quite similar to the Niagara-Hibbard head but was made distinctive by two fins cast onto the outside of the frame.

It was withdrawn from approval in October, 1912, and its manufacture was discontinued.

Harkness. The Harkness head was used to a large extent throughout the Middle States. The first type, made in 1887, was distinctive but the other three types, made in 1889-1890 and 1895, were all quite similar to each other. The No. 1 head was large and was threaded for a $\frac{3}{4}$ -inch connection. The valve and the deflector were all one piece and this was held in place by a heavy lever soldered onto an angle-shaped projection on the frame. The solder joint was thin and well located to receive the heat quickly.

The three other types were smaller heads threaded for $\frac{1}{2}$ -inch fittings. The valve was separate from the deflector but the valve spindle passed through a hole in the deflector and was held in place by a lever somewhat similar to but of better construction than that in the first type. The only important difference in these three heads was the shape of the solder joint which was L-shaped in the first, rectangular in the second and V-shaped in the third.

Kane. John and William Kane of Philadelphia invented several sprinklers subsequent to the No. 2 or "Eclipse." In 1888 the No. 3 "Bulb Root" was put on the market. In this head there was a hollow casting, the valve seating on a ring inside of the casting. The valve spindle extended through a $\frac{9}{16}$ -inch outlet in the

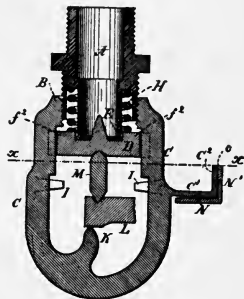

HARKNESS 1.

B, valve cap. M, strut.
L, lever. N, solder joint.

base of the casting and there was a small rotating deflector on the end of the spindle. The spindle was held in place by two levers, the second of which was held to a projection on the casting by a fusible link. This head distributed the water in a very fine spray but the interior valve caused a considerable friction loss.

The W. Kane No. 4 and the J. Kane No. 1 and No. 2 were quite similar to each other, being valve sprinklers with the spindle held in place by levers and a link similar to those used in the "Bulb Root" head.

The J. Kane No. 3 and No. 4, dated 1900 and 1902, respectively were heads of a modern design similar to the present International. The frame was of circular shape, the orifice being at the bottom and a toothed deflector being attached to the outside of the frame at the top. The metal valve cap was held over the orifice by two levers of the toggle joint type and a fusible link, consisting of two thin plates of brass, fitted into grooves at the ends of the levers.

John and William Kane operated under the name of the Universal Automatic Sprinkler Co. for a number of years but this company was sold and taken over by Clark Merchant & Co. in 1899. John Kane continued in business under the name of the John Kane Fire Extinguisher Co. until 1902, when he sold out to the International Sprinkler Co.

International. The International Sprinkler Co. was organized in 1899 by Clark Merchant & Co., with Mr. Powell Evans as President, and A. M. Lewis as Secretary. This company at first installed the Universal sprinkler but in 1900 began the manufacture of the No. 1 International head. This was very similar to the Universal sprinkler but had a somewhat narrower frame. In 1902 the head was slightly modified and was known as type A. This type gave trouble by breaking open

owing to weakness of the link. In 1904 type B with a wider link was used. This was installed very extensively by the International Sprinkler Co. of Philadelphia until 1911 when the company was absorbed by the "Automatic" Sprinkler Co. of America. It is now being used in some parts of the country. The numerous devices of this company were also installed by the following licensees:

New England: Rhode Island Supply & Engineering Co., Providence, R. I.

Chicago and the Northwest: Kellogg Makay-Cameron Co., Chicago, Ill.

Canada: W. J. McGuire & Co., Ltd., Montreal and Toronto.

Central and Southwest District: Standard Fire Extinguisher Co., Kansas City, Mo.

Francis Bros. & Jollett, Inc., were also licensed to install these systems within a district covered by an agreement.

The International Company also had approved alarm valves and dry valves.

Associated. Some of the gentlemen formerly connected with the International Sprinkler Co. formed, early in 1913, a new company known as the Associated Automatic Sprinkler Co. A sprinkler which was a duplicate of the International head, except for shape of frame, width of link and minor details, known as issue A, was approved by the Underwriters Laboratories in 1913.

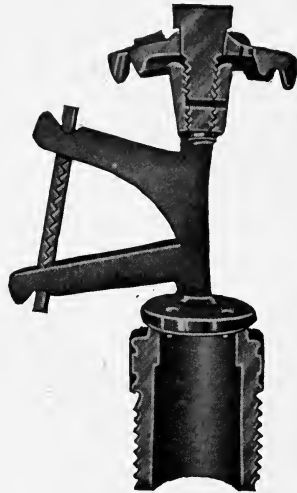

INTERNATIONAL.
(Section.)

Soon afterwards this head was replaced by the issue B sprinkler which was very similar except that the link was altered and made stronger by means of a depression and the deflector was redesigned.



ASSOCIATED A.

This sprinkler was approved by both the Underwriters Laboratories and the Mutual Companies and was used to considerable extent till 1916, when the Associated Automatic Sprinkler Company merged with the Globe Automatic Sprinkler Company.

Evans. Mr. Powell Evans, formerly president of the International Sprinkler Company, invented a sprinkler in 1913 which was quite similar to the International

sprinkler, although easily distinguished from it by the curved levers and thin deflector. In 1915 this head was slightly changed and was known as issue B. These heads together with alarm and dry valves were installed by the Merchant and Evans Co. of Philadelphia until 1916, when this company also merged with the Globe Automatic Sprinkler Company.



EVANS A.



KERSTETER 1.

Kersteter. Mr. Charles W. Kersteter of Chicago invented three sprinklers that had considerable use in the Middle West. They were all valve sprinklers with fixed deflectors. In the first head, patented in 1888, the valve was held closed by two levers, one on either side of the frame, the lower ends being hooked onto projections on the casting and the upper ends being held by a fusible link spanning the top of the head just over the deflector. The deflector was a large thin plate filled with triangular-shaped holes and teeth.

The two later types, dated 1893 and 1898, were of modern design, the valve being held by a strut composed of several small pieces soldered together.

About 1896 Mr. Kersteter started a company in

Cleveland, financed by Messrs. Corning & Chisholm, which soon sold out to the General Fire Extinguisher Co. Later he formed the Niagara Sprinkler Co. in Akron, O., but left this to organize the Phoenix Sprinkler Co. with Mr. Cook. This company put in devices patented by Jarvis Hunt for a few years. He left this company and returned to the Niagara Sprinkler Co. In 1910 he went to Milwaukee and became associated with the Rundle Spence Co.

Mackey. John C. Mackey of Syracuse, N. Y., invented in 1883 the No. 1 Mackey head which has already been mentioned. The No. 2 Mackey, dated 1885, was patented in 1889. In this head a metal valve disc closed an interior valve seat located inside of a hollow cylindrical casting. The valve spindle extended down through the orifice and as the stem was over $\frac{1}{4}$ inch in diameter and the orifice was only $\frac{1}{2}$ inch, the amount of water which this head could discharge was much below the normal. The valve stem was held in place by a

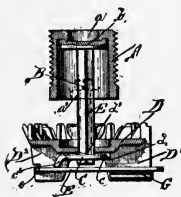

MACKEY 4.
(Section.)

link at the lower end of the head. In 1888 the head was improved and the No. 3 and No. 4 models were put on the market. In these heads the releasing device was somewhat changed so that there were two levers instead of one. The solder joint, which is similar in principle to that used in the modern Manufacturers head, consisted of a slot in

one of the levers through which a narrow projection from the casting passed. A V-shaped piece of thin brass was soldered to the end of this projection and overlapping the sides of the slot held the lever in place. All four of these heads had a metal-to-metal valve and were threaded for a $\frac{3}{4}$ -inch pipe outlet.

Manufacturers. The first three types of Manufacturers sprinklers, sometimes known as the "Manu-

facturers Mackey " type, were very similar to the last Mackey head. Some of these heads were made with " non-corrosive " agate or glass valves, and the last two types had an unthreaded projection about $\frac{1}{2}$ inch long extending beyond the threaded section. This was done to prevent sediment lodging in the head, but unless the pipe was of ample size at that point it was liable to obstruct the flow of water.

The last four types of Manufacturers sprinklers were quite similar to each other but of entirely different design from the former types. The $\frac{1}{2}$ -inch orifice was closed by a non-corrosive porcelain valve, thin copper and lead rings being used to make a tight seat. A hollow metal cap was placed over the porcelain valve and this was held in place by two levers of the toggle joint type. The ends of the levers were slotted and a fusible link, shaped like a double T, formed two shoulders against which the levers rested and by which they were held together.

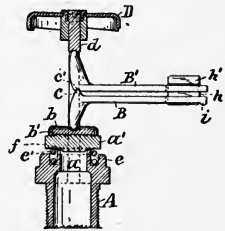

MANUFACTURERS.
(Section.)

Trouble was experienced in the earlier form of links from binding when the solder fused. In the later types, "B" and "C," the link was redesigned to overcome this trouble. There is still a considerable sliding motion in the link before the parts actually separate and this is a feature of design that is liable to allow the solder to become "frozen" by leakage from the valve before the solder joint is entirely free. This is more apt to happen in old heads where the metal has lost its elasticity.

There is also a coiled spring under the edge of the porcelain disc fitting into a groove in the casting. This tends to throw the disc up quickly when the head fuses. While this spring is embedded in wax it is liable after

years of exposure to corrode so as to lose its effectiveness. This, however, should not prevent the head from operating properly.

The Manufacturers' Automatic Sprinkler Co. bought out the sprinkler business of the Walworth Manufacturing Co. of Boston in 1901, and in 1911 they combined with the International Sprinkler Co. and the Niagara Fire Extinguisher Co. to form the "Automatic" Sprinkler Co. of America. This company installs all three types of sprinklers.

Neracher. Mr. William Neracher of Cleveland, O., invented seven types of sprinklers between 1884 and 1903, some of which were extensively used. He sold out to the General Fire Extinguisher Co., and was for many years their Cleveland agent. The first and second heads were drop deflector types, the valve and deflector being one piece. In the first head the valve was held against the orifice by a simple strut composed of two pieces, one of which was at a slight angle to the direction of thrust. This was held in place by a horizontal member soldered to the frame.

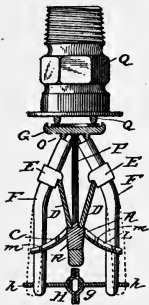

NERACHER 3.

The second head, dated 1887, was similar except that the lower part of the strut had a long arm extending horizontally and held to a projection on the frame by a triangular-shaped link. This style of link with slight modifications was used in all the later types. The four later types were all quite similar to one another. A metal valve cap closed the orifice and was held in place by a four-piece set of levers, the two long levers extending to the top of the head and being held in place by a link. This was a very elastic head and was particularly popular in sugar refineries because of its ability to withstand corrosion and the gumming effects of sugar,

and because the fusible link could be easily cleaned. The latest type is on the approved list but is not being extensively used as it is controlled by the General Fire Extinguisher Co. who ordinarily use the Grinnell head.

New York & New Haven. The two heads, known as the New York & New Haven, both dated 1889, were very similar and of the elbow type. The interior valve was

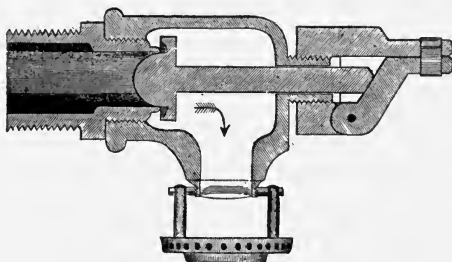

N. Y. & N. H. 2. (Section.)

fitted with a long spindle and rested against a shoulder in two hinged or hooked levers. These levers were held together by a fusible link, of much the same design as the last Bishop head. They were installed by the New York & New Haven Co. and by Foskett & Bishop of New Haven, Conn.

Newton. Robert Newton of Providence, R. I., invented a head in 1894 that was used quite extensively in Rhode Island and Eastern Massachusetts. It was a metal valve head with fixed perforated deflector. The valve was held in place by a balanced strut consisting of two parts set at an angle and bearing against two flat plates soldered onto a horizontal plate.



NEWTON.

The pressure tending to throw the plates off when the solder fused was small and the design was not well adapted to resist corrosion. This was rather

a short lived sprinkler, and after about ten years these heads failed to open properly and practically all were removed.

Phoenix. This head made by the Phoenix Fire Extinguisher Co. of Chicago was submitted for approval in January, 1908, and approved on recommendation of the Underwriters' Laboratories later in the year. It was installed for about four years by the above company and then withdrawn as the manufacture was discontinued.

The head resembled the Grinnell glass disc very closely except that the strut was of slightly different design, the diaphragm of different shape and the valve disc was metal instead of glass.

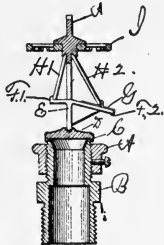

PIERCE.
(Section.)

Pierce. Octavius Pierce of Chicago patented a sprinkler in 1894 which was assigned to the Underwriters' Fire Sprinkler Co. It was a valve sprinkler with a strut built upon somewhat the same principle as the Newton head. It was used to some extent in the West.

Rockwood. Geo. I. Rockwood of Worcester patented a sprinkler head in 1906 which was modified and approved



ROCKWOOD B.



ROCKWOOD D.
(Section.)

in 1907. This was a valve sprinkler with a silver washer under the brass valve cap. The valve was held in place by a four-piece strut in the form of a triangle with the

vertical member a little off center. The deflector was a "double decker," part being under and part over the main casting. This head was slightly modified during the next two years, the new designs being known as issue B, C and D. In the issue C head the solder joint was strengthened. In the issue D type the double deflector was abandoned and a single deflector on the outside of the frame was substituted.

This head was originally installed by the Worcester Fire Extinguisher Co., the company being later reorganized as the Rockwood Sprinkler Co. The head is being extensively used today all over the country. The issue A type gave some trouble by opening prematurely, on account of the weakness of the solder joint. These were practically all replaced by the makers. The other types are entirely satisfactory.

Walworth. This sprinkler was very extensively used, especially in New England, from the time it was invented, 1883, down to 1901. There are nine distinct types recognized besides a few minor modifications which are not important.

In all these types the same general characteristics were retained. Up to 1888 it was distinctly a pendent head and would not operate properly in any other position. In that year the first upright heads were made, a spring being inserted to throw up the deflector and hold it in that position. In 1892 a specially designed upright head, known as No. 5, was made in which the valve was held closed by a lever with an upright arm. The deflector, which was perfectly smooth, was attached to the upper part of the frame.

In 1894 this head was improved by making the deflector cup shaped, with perforations near the edge and by putting on a double link to lessen the danger of premature opening.

In 1898 the pendent head was improved and a new

head, known as No. 8, with a greatly improved deflector was substituted. The next year the upright head was improved in a similar manner. All the later types had double links and it was customary to wire these two links together. Occasionally these were wired on the side (long dimension) instead of on the end, thus binding the sliding parts together and preventing the proper operation of the head.

The Walworth head was generally approved by local boards and the Factory Mutual Insurance Companies and was extensively used until 1901 when the Walworth Manufacturing Co. sold the sprinkler business to the Manufacturers Automatic Sprinkler Co. and the head was no longer made. This head had a good record up to about 1911 when tests showed that its age limit had been about reached, as many heads that were tested

about that time either stuck or were very sluggish in action. It did not resist corrosion as well as many types and in many instances there were defects in workmanship. Numerous cases have been discovered where high-test solder was carelessly used on low-test heads. It is today considered defective and is being very generally replaced.



ESTY 5.

Esty. This head was patented by William Esty of Laconia, N. H., in 1895. It was a valve sprinkler with a solder joint of

the duck-bill type. The first four types, known as the "plain," "corrugated," "knob," and "pin," were experimental types and but few of them were installed. In 1896 the No. 5, or spring type, was invented in which the duck bills were soldered together for part of

their length, the rest of the surface being cut out to form a pocket in which a steel spring was inserted. This pocket was filled with wax to protect the spring against corrosion.

In 1903 the head was slightly modified and the new type was known as No. 6.

This head was never approved by the Underwriters Laboratories. The issue B sprinkler made in 1912 was approved and this type has been extensively installed since then.

They are made by the Esty Sprinkler Co. of Laconia, N. H., and are installed mostly by the H. G. Vogel Co. of New York and Montreal.

Babcock. The Babcock sprinkler was patented by E. F. Steck of Chicago in 1897. It was installed by the Fire Extinguisher Manufacturing Co. of Chicago. A few thousand were installed. After a few years these heads gave trouble on test by sticking of the strut levers and sticking at the seat and most

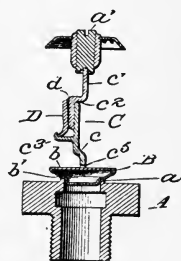

BABCOCK.
(Section.)

of them were removed. The head was of modern design, the valve disc being hollow, and held in place by a strut.

Grinnell. The General Fire Extinguisher Co. is perhaps the best-known sprinkler company in the country, and in fact in the world. There have been more Grinnell sprinklers than any other make installed in this country and they are very extensively used abroad. Starting with the Providence Steam & Gas Pipe Co. — a small piping concern in Providence, R. I. — Mr. Frederick Grinnell, by his ingenuity as an inventor and ability as an organizer, soon made the company famous throughout the world.

In 1893 the company was reorganized as the General Fire Extinguisher Co. with offices and factory at Provi-

dence, R. I., and plants at Warren, O., and Charlotte, N. C. Mather & Platt, Ltd., were appointed agents for Great Britain and the continent with a factory at Manchester, England.

The General Fire Extinguisher Co. was the first company to put on the market a full line of automatic sprinkler system devices including, besides the sprinkler head, a dry-pipe valve and an alarm valve.

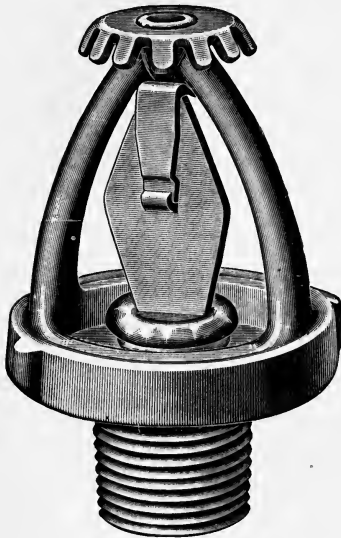

View.

GRINNELL GLASS DISC.

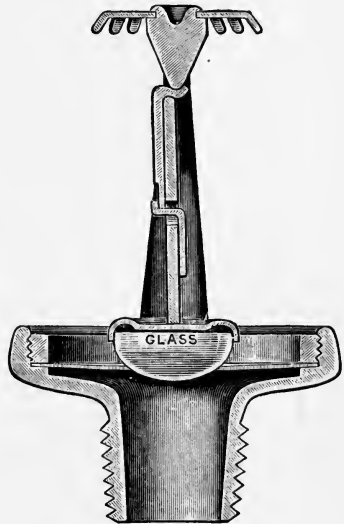

Section.

The four types of Grinnell metal disc sprinklers were made from 1882 to '88, and were all similar in construction. The principal differences were in the kind of metal used for the valve disc and the width and shape of the seat ring. In 1890 the Grinnell glass disc sprinkler, which is essentially the same as the head now used, was invented. This was quite different from the metal disc heads in appearance but embodied many of the same

principles. The same style of diaphragm was used but the valve cap, instead of being of metal and seating on a raised rim formed in the diaphragm, was of glass and projected into the $\frac{1}{2}$ -inch hole in the diaphragm. The



GRINNELL SPRINKLERS IN A DEPARTMENT STORE. PIPING CONCEALED AND CEILING DECORATED BY ROSETTES OF A SIMILAR SHAPE TO A SPRINKLER. ROSETTES OMITTED AT PROPER PLACES AND SPRINKLERS SUBSTITUTED.

diaphragm was made thicker so that it needed no auxiliary plate to prevent collapse when the pressure was released. The glass disc was semi-spherical in shape, the curved side resting in the orifice and the flat side being protected by a metal cap. The orifice was faced with hard solder so that a tight joint could readily be secured.

The valve was held in place by a strut composed of three interlocking pieces of metal soldered together. The deflector was quite small in diameter and had a row of teeth projecting from the circumference at almost a right angle. The head was improved in 1903 by making the frame heavier and the deflector thicker but no change was made in the principles involved.

The head is especially neat and symmetrical in appearance and is particularly well adapted for decorative effects with concealed piping. It has now been on the market for twenty-three years practically in its present form and has very seldom failed to operate from the effect of age alone.

The General Fire Extinguisher Co. has absorbed many of its competitors, including the Neracher, Hill, Granger, Gray, Star, Jahn, Swan and Harkness companies.

While the approved sprinklers of today may not be perfect it is certain that they have been developed to a point where there is little in the way of improvements that can be suggested. The test of time may show defects that cannot now be predicted but, taken as a whole, the automatic sprinkler is an extremely reliable device.

CHAPTER IV

TESTS AND CHARACTERISTICS OF SPRINKLERS

WOODBURY TESTS

The first important tests upon automatic sprinklers made by the insurance interests were those of the Factory Mutual Fire Ins. Cos. in 1884. These tests were made by Mr. C. J. H. Woodbury, Inspector, and afterwards Vice-President of the Boston Mfg. Mutual Ins. Co., assisted by Mr. F. E. Cabot, Inspector and afterwards Secretary of the Boston Board of Fire Underwriters. These tests were extremely comprehensive and were reported in a pamphlet covering 58 pages. The following heads were tested: Parmelee 5, Grinnell "B," Brown standard (sealed type), Brown sensitive, Walworth soldered arm, Walworth solder link, Burritt sealed (rose type), Burritt sensitive 3, Bishop sealed 1, Bishop sealed 1½, Bishop sealed 2, Bishop valve deflector with cup joint, Bishop valve deflector with conical sleeve, William Kane Eclipse 2, Harris deflector, Harris closed, Whiting Hub, O. C. Heath (revolving head), Ruthenburg.

The results and conclusions are summarized as follows:

1st. That time and pressure has not affected the strength and fusion point of the solder during an experience of twelve years.

2nd. Portions of sprinklers where corrosion might interfere with prompt action should be protected, preferably by heavy mineral oil.

3rd. The distribution of water between three and thirty-six pounds pressure is such that water is directed upon a smooth ceiling and upon each square foot of floor, with all of the sprinklers used in these experiments.

4th. The concentration of water at the beginning of a fire is greater than by any other form of inside apparatus.

5th. Where tanks are used for a first supply for sprinklers, the bottom of the tank ought not to be less than ten feet above the sprinklers.

6th. As a matter of practical application, sprinklers have worked at 131 mill fires in seven years without any known instance of their failure.

7th. The results of the experience in respect to automatic sprinklers demonstrate that their efficiency is not liable to become impaired by time, and prove the good judgment of those underwriters who advocate their introduction as a safeguard against loss.

8th. It is essential that valves be so arranged that the proper persons can readily know that a full-water pressure is upon the sprinklers. Valves with traveling stems are preferable on this account. Valves with stationary stems can be fitted to show their position by winding around the valve stem a line with a weighted tag at the end. When the valve is open or shut, the tag will hang in a corresponding extreme position of the line. Left-hand valves should not be used in sprinklers. It is well to secure the valves open with a riveted strap; if it is necessary to shut the valve on account of mishap, anybody can cut it; but do not use a lock and chain, as the key will, in the nature of things, be lost, and the valve spindle bent, in the efforts to sunder the chain."

Sensitiveness. Tests on sensitiveness were made as follows:

"With the purpose of employing a method which would give precise results, the following apparatus was devised for the object of learning the relative sensitiveness of automatic sprinklers under pressure: A box of thirty cubic feet capacity, measuring three by four feet, and two and a half feet deep, was swung top downwards over a large table. A Parmelee sprinkler head projected through the center of the table, and was connected with a piece of four-inch pipe about two feet long, which was beneath the table, and capped at both ends. Water was placed in the lower end, and connections were made with a steam supply and a steam gauge. This arrangement served to furnish a supply of saturated steam at any desired pressure, and therefore the quantity of heat and its temperature could be known and controlled. The sprinklers were screwed into a framework of fittings which was placed on the table, so that the sprinklers under trial were about two feet above the table. The

sprinklers were filled with water at the temperature of the room, and weights applied in such a manner as to be equivalent to a water pressure of fifteen pounds to the square inch upon the sprinklers. Electric apparatus was attached, so that when any sprinkler opened, a bell corresponding to each sprinkler would ring in an adjoining room. On making a trial, the box was lowered upon the table, and the temperature increased very slowly to 112 degrees, and then the valve was opened and steam blown through the Parmelee sprinkler head into the box. It required two minutes to increase the temperature within the box one hundred degrees, and the circulation of the steam was so rapid that thermometers inserted through orifices in various parts of the box varied less than one degree from each other. Although this was not the heat proceeding directly from a fire yet it enabled the use of constant conditions, and the results with any one sprinkler, as given in the record, do not vary from each other more than would correspond to varying masses of solder in the joint."

Tests on sensitiveness showed the following time necessary to open the different heads.

Averages.	Time in seconds.	With Grinnell as 100.
Grinnell.....	15	100
Kane.....	15	103
Walworth link.....	17	116
Bishop sensitive, with cup.....	18	123
Bishop sensitive, with sleeve.....	19	132
Brown sensitive.....	21	140
Burritt sensitive.....	26	180
Bishop sealed upright.....	30	202
Walworth soldered.....	31	212
Bishop sealed deflector.....	34	236
Burritt rose, open base.....	38	260
Parmelee.....	52	357
Burritt rose (hard solder).....	63	432
Brown standard.....	80	548
Harris deflector.....	85	581

Bursting Strength. The tests on bursting strength showed a wide variation, the heads leaking at from 70 to 6000 pounds per square inch. Some of the heads were new and some had been in use for 3 years or less.

Distribution. The tests on distribution showed that under 3, 13, 22 and 36 pounds pressure the heads ranked as follows:

3 pounds per square inch.	13 pounds per square inch.	22 pounds per square inch.	36 pounds per square inch.
Parmelee Grinnell Burritt rose Kane	Parmelee Burritt rose Grinnell Bishop sealed deflector	Parmelee Burritt rose Grinnell Brown sensitive	Parmelee. Burritt rose. Grinnell. Burritt sensitive.
Brown sensitive	Brown sensitive	Bishop sealed deflector	Kane.
Grinnell placed upright	Burritt sensitive	Burritt sensitive	Brown sensitive.
Bishop upright	Grinnell placed upright	Grinnell placed upright	Bishop sealed deflector.
Burritt sensitive Bishop sealed deflector Walworth	Walworth Kane Bishop upright	Bishop upright Walworth Kane	Bishop upright. Walworth.

Discharge. The cubic feet of water discharged per minute under 3, 20 and 50 pounds pressure including 5 feet of $\frac{3}{4}$ -inch pipe and one elbow was as follows:

Name.	3 pounds.	20 pounds.	50 pounds.
Parmelee.....	0.83	2.14	3.38
Burritt rose.....	1.09	2.81	4.44
Burritt open base.....	1.48	3.82	6.03
Bishop.....	1.28	3.29	5.21
Bishop sealed.....	1.70	4.38	6.92
Brown standard.....	1.06	2.75	4.35
Heath.....	1.01	2.61	4.12
Whiting (Hub).....	0.94	2.41	3.82
Grinnell.....	0.96	2.48	3.93
Burritt sensitive.....	1.10	2.83	4.47
Brown sensitive.....	1.20	3.09	4.88
Walworth.....	1.33	3.43	5.42
Bishop (valve).....	1.65	4.25	6.72
Kane (Eclipse).....	1.07	2.76	4.36
Harris deflector.....	1.26	3.26	5.16
Harris (closed).....	0.90	2.31	3.65
Ruthenburg.....	1.30	3.35	5.29

The following is also noted:

“Sealed sprinklers should not be connected directly to distributing pipes, in the manner of valve sprinklers, because the circulation of water after one sprinkler has opened is sufficient to cool the sprinkler and prevent the prompt operation of the remaining sprinklers; and it is only when placed at the ends of branch pipes in the proper manner, that sealed automatic sprinklers should be approved for protection against fire.”

SPRINKLER SOLDER

It might be well to describe here the low-fusing solder used in automatic sprinklers as it has been practically the same in all makes from the earliest heads to those of modern times. Strange to say there has been practically no improvement in this detail of sprinkler construction, perhaps because none was needed. It was Sir Isaac Newton, in 1699, who first discovered that certain alloys possessed a lower melting point than their constituents. He devised a mixture of bismuth 5 parts, lead 3 parts, and tin 2 parts, which melted at 212° F.

Barnabas Wood of Nashville, Tenn., took out a patent in 1860 upon which the composition of sprinkler solder was afterwards based. The usual formula is:

Bismuth.....	4 parts
Lead.....	2 parts
Cadmium.....	1 part
Tin.....	1 part

This has a melting point of about 165° F., though it granulates a few degrees lower. Woodbury in his tests found that when a mass of this solder is cooled slowly there will be a variation in the different portions of the bar, due to the tendency of mixtures of metals to separate into well-defined alloys.

He tested 19 samples of solder from nine manufacturers and found the melting points of the low-test solder varied from 161 to 172 degrees. Solder cooled in ice water began to soften at 6 degrees lower temperature

than when cooled slowly. He also found a variation of from 2 to 26 degrees between the point at which the solder softened and at which it actually melted.

By changing the proportions of the above formula slightly, a melting point of 159.8° can be obtained. Lower melting temperatures can be obtained by adding an excess of bismuth but this makes the solder too brittle. The above formula gives the lowest melting point that is sufficiently hard, ductile and permanent for sprinkler work.

The melting points of the constituents are:

Cadmium.....	600° F.
Lead.....	504° F.
Bismuth.....	476° F.
Tin.....	421° F.

LEAKAGE

The matter of leakage from sprinkler heads has been an important consideration ever since sprinklers were first installed. It was frequently used as an argument by mill owners against installing the device, and the comparatively few cases where trouble did occur were brought forward to support the argument. The matter was investigated by the Factory Mutual Fire Insurance Cos. in 1885. Letters were sent to plants equipped with sprinklers and replies were received as follows:

Total number of replies received 224.	
Number of leaks not due to accident.....	22
Number causing no damage.....	16
Number causing slight damage.....	6
	<u>22</u>
Number of leaks caused by accident.....	41
Number causing no damage.....	27
Number causing slight damage.....	14
	<u>41</u>
Total number of leaks.....	<u>63</u>

Many of the older heads developed slight leaks which did no damage. A large part of these old heads were

adjustable so that when they began to leak the valve could readily be tightened.

FIRE RECORD

A record of fires in buildings equipped with sprinklers and buildings not so equipped was tabulated by the same organization. In the sprinklered class only fires starting in sections equipped with sprinklers were included. The results were as follows:

	1877-1887	1877-1894
Average loss per fire — sprinklered buildings.....	\$1,081 (205 fires)	\$1,360
Average loss per fire — unsprinklered buildings.....	\$17,613 (759 fires)	\$16,104

Mr. Woodbury states in his report that sprinklers of the sensitive type cause less water damage than those of the sealed type because fewer of the former operate.

Fire Record of Old Heads. The record of some of the earlier types of sprinklers in actual fires between 1877 and 1885 was tabulated in his report as follows:

Head.	Number of fires.	Loss per fire.
Walworth.....	6	\$2487
Harris.....	3	972
Brown.....	3	4040
Barnes.....	3	611
Kane.....	2	45
Parmelee.....	83	262
Grinnell.....	102	112
Burritt.....	17	1207

LATER MUTUAL TESTS

A second series of tests was made in 1886 and was also in charge of Mr. Woodbury. The tests on sensitiveness were made by placing the heads in a building 20 by 30 feet and 10 feet high. Six sprinklers were installed

on piping near the roof, under a pressure of 35 to 40 pounds. They were subjected to heat from a fire consisting of $\frac{1}{2}$ barrel of shavings to which excelsior was added if necessary. The time necessary to open the different heads under these conditions was as follows:

Grinnell.....	1 minute,	4 seconds
Granger.....	1 minute,	33 seconds
Gunn.....	1 minute,	34 seconds
Star.....	4 minutes,	36 seconds
Kane (Excelsior).....	6 minutes,	12 seconds
Walworth.....	6 minutes,	55 seconds
Braman Dow (Jordan).....	7 minutes,	38 seconds
Buell, stuck in 3 cases out of 5.		
Kane (reversible), stuck in 1 case out of 4.		

APPROVED SPRINKLERS

The approved list of the Mutuals in 1886 included the following: Grinnell, Buell, Kane, Walworth and Gunn. Later the Clapp, Neracher and Hill heads were added. Those approved in 1894. were: Grinnell, Hill, Neracher, Clapp, Wm. Kane (all put in by the General Fire Extinguisher Co.), Esty, Walworth, J. Kane, Newton and Kersteter.

The heads approved by the New England Insurance Exchange were as follows:

In 1892, Buell, Grinnell (metal and glass disc types), Harkness, Hill, Kane, Neracher, Mackey, New York & New Haven, Walworth.

In 1896 the Buell, Harkness, New York & New Haven had been taken off the approved list and the Newton and Esty added.

In 1900 the following heads had been added: Jahn, Hibbard, Babcock and Universal.

List of approved sprinklers of the National Board of Fire Underwriters, Jan., 1918:

- Crowder, A, Crowder Bros., St. Louis, Mo.
 Esty, B, Esty Sprinkler Co., H. G. Vogel, sole agents,
 New York City.
 Globe, C, Globe Automatic Sprinkler Company,
 Philadelphia, Pa.
 Grinnell, Improved, General Fire Extinguisher Co.,
 Providence, R. I.
 Independent, A, Independent Ætna Sprinkler Co.,
 Philadelphia, Pa.
 International, B, International Sprinkler Co., New
 York City.
 Lapham, B, Ohio Sprinkler Co., Youngstown, Ohio.
 Manufacturers, C, Automatic Sprinkler Company
 of America, New York City.
 Neracher, Improved, General Fire Extinguisher Co.,
 Providence, R. I.
 Niagara, B, Automatic Sprinkler Co. of America,
 New York City.
 Rockwood, D, Rockwood Sprinkler Co., Worcester,
 Mass.

SIZE OF ORIFICE

The $\frac{1}{2}$ -inch diaphragm or ring-nozzle outlet has been taken for the standard and practically all sprinklers as made today comply with this standard. A few heads with 1-inch outlets, called jumbo heads, have been made for use at the top of elevators and similar places but these heads are much less sensitive and it is considered better practice today to install several smaller ones in place of one large head. There is a slight difference in the discharge from the different makes of heads but the following table gives a fair average.

DISCHARGE FROM SPRINKLERS

Pressure at sprinkler, pounds.	Water discharged, gallons.
5	15
10	19
15	24
20	28
25	31

Failures from Age. The limit of life of a sprinkler is something that is generally overlooked by the property owner who puts in an equipment. It is quite commonly assumed that so long as no fire occurs they have no work to do and should last indefinitely. As a matter of fact they are called upon to do work all the time, namely, to hold back the water pressure in the pipes, and like any other machine they have a limited life. One reason for this misconception is the fact that sprinklers do not show their age and defects to the casual observer. A head that has been in use for 20 years may appear to be as good as new except that it is not so bright and clean; yet when it is heated it may be found that owing to the constant strain, the metal has lost its elasticity or certain parts may have stuck together so that it will not operate.

The greatest number of failures in old sprinklers are those due to sticking of the valve where some soft metal like lead has been used for a valve disc. The disc becomes so indented that it may require a pressure of 100 pounds or more to force it off especially when the orifice has a sharp edge or burr.

All the Grinnell metal disc sprinklers used lead or some similar soft metal for the valve disc but after a very successful career of from 20 to 30 years they have been found in such an unsatisfactory condition that they have all been condemned as defective. The Walworth

head contained a lead valve disc covered with a copper washer. This was certainly better than lead alone, yet after giving good service for 10 to 25 years many of them have been found to stick at the seat so as to utterly fail on test.

Perhaps the next most important defect is the design that allows of the slow opening of a head and does not protect the solder joint from water leaking from the head. Unless the sprinkler opens promptly and with a snap, a small stream of water is liable to be liberated when the head starts to open that may strike the solder joint and chill it. This would ordinarily cause a complete failure of the head. This has occurred in many of the older heads where the parts are liable to lose their elasticity, notably the Walworth. Any joint where there is considerable sliding action before it parts is undesirable for this reason.

Sticking and binding of the movable parts after the solder has fused is another important defect that develops in many of the older designs. This is due to imperfect design and workmanship but is much less noticeable in modern heads. This has occurred in some of the earlier types of Manufacturers heads, in the Newton head and in the Grinnell metal disc heads.

Another feature that has caused a great many heads to open prematurely is the tendency of the solder joint to give way owing to excessive strain on the soft solder. This feature is often difficult to judge without the test of time although the laboratories are able to imitate the actual conditions upon an exaggerated scale so that the results can be observed in a comparatively short time. Sprinkler solder is soft and will not withstand heavy tension and shearing strains. It is also more or less viscous and will flow very slowly, like a glacier, when under strain. It is necessary therefore to arrange the leverage of the releasing parts so that

the solder will not be overstrained and yet will be under sufficient strain to allow a quick sharp action when it fuses.

Limit of Age. It is difficult to give any reliable data as to the limit of age of sprinklers as different types vary greatly and heads of the same type vary in different localities and under different conditions. In general it may be said that for heads in dry, clean, locations not subject to corrosive influences the earlier types remained in good condition for about 10 years. Heads of a later date, made from 20 to 25 years ago, were mostly in good condition for 20 years. Modern approved heads have not been in use long enough to allow the effects of age to develop but it seems probable that they will last much longer than those of the older types.

Corrosion. There are many corrosive influences which affect sprinklers, amongst which are nitric and

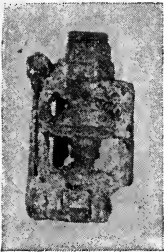

CORRODED WAL-
WORTH SPRINK-
LER.

hydrochloric acids, chlorine, sulphurous and ammonia fumes. Some forms of corrosion act on the surface of the solder, coating it with a hard crust which holds the moving parts together and prevents the solder from flowing after it has melted. Other forms act on some of the ingredients of the solder, generally the bismuth or cadmium, changing them chemically and making the whole mass of solder hard and brittle. The most active forms attack the whole sprinkler,

forming a heavy coating which prevents the moving parts from being released.

Certain of the older types of sprinklers like the Walworth, Draper and old Manufacturers were especially susceptible to corrosion, but all heads on the approved list today are constructed so as to reduce the chances of trouble from this source to a minimum.

There have been many plans suggested for preventing corrosion of sprinklers including painting and coating with various kinds of wax. Paint is undesirable as it tends to cause sticking of the moving parts. Wax coatings have proved quite satisfactory where the right kind of wax was used, and when it was properly applied. It should have a melting point below that of the fusible solder and yet not so low that it will soften or run in hot weather. Paraffine has been used but it has too low a melting point. A preparation of ozokerite (mineral wax) has been found most satisfactory and most of the sprinkler companies now supply a coating of this kind. The head is dipped in hot wax, care being taken that this is hot enough so that it will cover the head evenly and yet not so hot that it will melt the solder. The heads should be carefully treated and it is much safer to leave this work to the manufacturers. In screwing the head into the fitting this coating is apt to become cracked or broken and it is necessary to go over all broken places with a hot knife in order to make the coating complete and effective. If this is carefully done the head should last for many years, even in very corrosive locations.

No coating has yet been put on the market that is suitable for highest heads in hot places. The General Fire Extinguisher Co. has recently put out a glass-covered head, which is a modification of a former device of the same company, and which seems to fill a long felt want. The frame of the sprinkler has been enlarged to make room for a groove in the circular casting outside the arms. This groove is filled with a thick non-drying

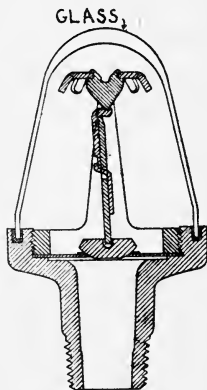

GRINNELL SPRINKLER
WITH GLASS COVER.
(Section.)

grease and an oval-shaped glass flask, which covers the upper part of the head, fits into this groove, making a corrosion-tight joint. When properly installed this is very effective in preventing corrosion and can be used on high- as well as low-test heads. The heat radiates through the glass so rapidly that the melting point of the head is only raised a few degrees. When the head fuses, the pressure of the water throws off the glass cover.

Painting. Both paint and whitewash seriously affect the operation of sprinklers and the moving parts should never be coated with these materials. If a ceiling is to be painted with a spraying machine, the sprinklers can be covered with small paper bags during the operation.

Rotating Deflectors. In many of the older heads the deflectors were made to rotate when the stream from the orifice struck them, in order to improve the distribution. In modern heads the deflectors have been so perfected that this is no longer necessary. In fact, it is now considered an undesirable feature because the vibration in certain buildings, like weave sheds, will set the deflector in motion and this constant motion will frequently wear the parts so badly that they become loose and defective. A number of sprinklers have been taken from the weave sheds of cotton mills where the



ESTY SPRINKLER
WITH DEFLECTOR
WORN BY VIBRA-
TION.

deflectors were missing, having been so badly worn by constant vibration that they dropped off. In the case of one upright Esty head the deflector was almost cut through by becoming loose and dropping onto the sharp duck-bill lever which holds the valve disc in place.

Valve Discs. Mr. C. J. H. Woodbury, in his first report on automatic sprinklers in 1884, stated that "Lead is the only material which has been used with success in sensitive automatic sprinklers" for valve discs. The test of time has thrown an unexpected light on this subject, for the experience of 35 years has shown that this is one of the few metals that is not suitable for this purpose. The art of sprinkler construction has advanced so that it is entirely practical to make a tight joint with a harder metal that will afford much less chance for sticking. Brass against brass is not entirely satisfactory as it is hard to keep the joint tight. The most successful valve discs have been glass, as used in the Grinnell head; porcelain with a copper and lead washer, as used in the Manufacturers head; brass with silver washer, as in the Rockwood; and brass with copper washer, as used in the International and other heads.

High-test Heads. The ordinary sprinkler has a melting point of about 160° F. Experience teaches that it is not safe to install such heads in locations where the temperature frequently exceeds 110° F. This is because at this temperature the solder is more subject to cold flow than at lower temperatures so that in the course of years the head is liable to open. It is, of course, frequently necessary to install sprinklers in rooms that are hotter than this, so that high-fusing sprinklers are necessary. In the early days each manufacturer made the high-test melting points to meet his own ideas and there was considerable variation. The Walworth Company, for instance, used solders melting at approximately 200° F. and 300° F. Many of the older heads were unmarked and some were incorrectly marked and were therefore liable to be incorrectly installed. The General Fire Extinguisher Co. early adopted the following melting points which have now become universal: 212°, 286° and 360° F.

A safe rule for installing high-test heads is to allow 60 to 80 degrees leeway. That is, if the temperature in the room exceeds 100° F., but does not exceed 160° F., use 212° heads. This head is usually safe in boiler rooms, hot engine rooms and skylights. If the temperature exceeds 160° F. but does not exceed 210° F., use a 286° head. This is suitable for most dry rooms. If the temperature exceeds 210° F., use a 360° head.

The 286° head is slow in operation and therefore somewhat unreliable. It should never be used unless absolutely necessary and even then the protection cannot be considered first class. There are several cases on record where disastrous fires have occurred in rooms equipped with these heads, where the only probable explanation was the slowness of the heads in operating.

The 360° heads give but poor protection and should only be used in rare cases where a very high temperature is maintained, such as in extra hot dry rooms.

The Underwriters' Laboratories and the Factory Mutual Laboratories require all high-test heads to be plainly marked to show their operating point, both by stamping this temperature on the head and by painting the frame with a distinguishing color. For 212° heads, white is used; for 286° heads, blue; and for 360°, red.

Defective Heads in Use. Amongst the heads that are found to some slight extent in risks today and that should be, in general, considered defective are:

- Grinnell — metal disc.
- Walworth — all types.
- Manufacturers A.
- Mackey — all types.
- Babcock.
- Hibbard — certain types.
- Hill.
- Buell — all types.
- Newton.

Cost of Equipments. The cost per head of equipping a building with sprinklers has gone up very rapidly the last few years; while formerly an equipment could be put in for \$3.00 to \$4.00 a head, the cost today is nearer \$10.00 a head. This is due to an increase both in stock and in labor and is probably a temporary condition.

The type of building has considerable effect on the price and under some conditions the cost may go up to \$15.00 or \$20.00 a head.

Extra sprinklers cost about \$1.00 each.

TESTS FOR ACCEPTANCE

Up to 1901 the testing and approving of sprinklers was done by the local insurance boards, and bureaus. As the art of making and installing the device improved and as their success in extinguishing and holding fires became more marked, the insurance interests were willing to give more and more discount in rates for the installation of sprinklers. It was evident from the first that some makes had more merit than others and that only those that, after careful and disinterested tests, were found to be free from important defects should be given credit. The local boards who made the rates therefore found it necessary to make tests on the different heads submitted before they could properly pass on their merits. This resulted in a good deal of confusion for a head approved in one territory might be barred out in the adjoining territory.

In 1901 the Underwriters' Laboratories of Chicago began the testing of sprinklers and other fire appliances. They took up the work in a much more thorough and systematic manner than had ever before been attempted, and their findings, as promulgated by the National Board of Fire Underwriters, were almost universally

adopted by the local organizations. This and the drawing up of rules for the installation of sprinklers by the National Fire Protection Association in 1896 were the two greatest steps ever taken toward uniformity in the automatic sprinkler industry.

REQUIREMENTS FOR CONSTRUCTION OF AUTOMATIC SPRINKLERS

The following rules for the construction of an automatic sprinkler head give a fairly complete outline of the requirements which an approved head should fulfill.

1. *Discharge Capacity.* As a basis for these rules, it is required that each automatic sprinkler have an unobstructed outlet of such size and form that with 5 pounds pressure maintained at the sprinkler, it will discharge approximately 12 gallons per minute.

2. *Pressure Test.* An automatic sprinkler upon original test must not leak at or under a pressure of 300 pounds hydrostatic pressure.

3. *Water Hammer Test.* Sprinklers upon original test must not burst or leak by suddenly increasing the pressure from 0 to 300 pounds, repeated 500 or more times.

4. *Fusing Point.* An automatic sprinkler when intended for ordinary use must, when immersed in hot fluid, fuse at not less than 155° F., nor more than 165° F. Head not to be under pressure in this test. "Hard heads," in like manner, must fuse at not less than 275° F. or more than 300° F. The fusing point of solder should not change with age.

5. *Action in Opening.* On original test an automatic sprinkler on fusing must open without perceptible halt or hesitation at any point of the opening action. All freed parts must be thrown clear. This test to be made without subjecting the sprinkler to pressure, or depending upon the action of a coiled spring.

6. *Position.* An automatic sprinkler must be designed to open and spray satisfactorily in an upright or pendent position.

7. *Distribution of Water from Sprinklers.* Sprinkler upright or pendent with deflector 4 to 6 inches below smooth ceiling and 10 feet above smooth floor:

(a) Shall, under 5-pound nozzle pressure, wet ceiling over an area of not less than 3 to 4 feet in diameter.

(b) Shall, when under 5-pound nozzle pressure, throw approximately 90 per cent of water inside an area 10 feet square on floor.

(c) Shall, when under 50-pound pressure, throw not less than 75 per cent of water inside the 10 feet square area.

(d) Distribution in both above tests to be approximately uniform over the 10 feet square area.

(e) Water should not be cut up into fine spray.

(f) Rotary deflectors are allowable, but the distribution must be satisfactory with deflector fixed.

(g) The distribution in any direction shall not be obstructed by yoke, levers or other parts of sprinkler.

8. *Materials.* Automatic sprinklers must contain no iron, steel or fibrous material subject to the effect of corrosion.

The following is a brief summary of the tests and examinations made by the Underwriters' Laboratories on new sprinklers submitted for approval.

TEST SPECIFICATIONS—AUTOMATIC SPRINKLERS

1. Hydrostatic Pressure.

(a) *Leakage.* Heads are tested under a hydrostatic pressure ram with gage readings from 0 to 2400 pounds. Readings are taken of leaking points and any heads leaking under 300 pounds are noted. Similar readings are taken at intervals of 30 to 300 days.

(b) *Steady Pressure.* Heads are put under a constant pressure of 300 pounds for 3700 hours (154 days), and any leakage noted.

(c) *Water Hammer.* Sprinklers are placed on piping connected to a cylinder with a plunger. A weight is dropped onto the plunger from a predetermined point.

2. *Hot-air Oven.* Tests are made in a cylindrical water-jacketed copper gas heated oven. Diameter 10 inches, height 30 inches. Heads attached to pipe and tested under a hydrostatic water pressure of 5 pounds.

RATE OF HEATING

Time.	Temperature.
0	100
1	150
2	190
3	218
4	235
5	250

Clean heads are tested and also heads subjected to ammonia fumes, sulphurous fumes, chlorine fumes, hydrochloric acid fumes, nitric acid fumes, two coats white lead and boiled oil, four coats shellac, three coats asphaltum, two coats calcine.

For corrosion of seats a saturated solution of sal ammoniac under 5 pounds pressure is held against the seats during a period of 30 days and the head is then dried:

3. Hot Fluid.

(a) *Fusing Point in Water.* Heads are immersed in 1 gallon of water and temperature raised gradually to 100° F. Temperature is then raised at a rate not exceeding 2° F. per minute. Opening temperature of sprinkler is noted.

(b) *Plunge in Water.* Heads are allowed to stand at least 1 hour in water of 60° F. Then removed and immersed in a water bath at 175° F. Time of fusing under these conditions noted. High-test heads are tested in a similar manner in melted leaf lard.

4. **Intermittent Flame.** Heads are tested under 5 pounds hydrostatic pressure by gas flame, 10 inches long, coming from a 1-inch orifice under 6-inch pressure applied intermittently. Record taken of the number of applications of flame before heads open.

5. **Distribution.** Heads are tested under 5 and 25 pounds nozzle pressure and record made of the diameter

of circle wet on ceiling and on floor; also per cent of water falling within a 10-foot circle, etc.

6. Design and Construction. Heads are examined for effect of blows, effects of excessive tension and compression, uniformity of parts and workmanship.

7. Record in Service. Includes number in service, length of time in service and record.

CHAPTER V

INSTALLATION RULES

The rules of the National Board of Fire Underwriters for the installation of automatic sprinklers are the standard for all stock companies interests in the country. The rules of the Associated Factory Mutuals are practically identical.

These rules give in detail the information necessary for the proper installation of sprinkler equipments and as they are subject to revision every few years care should be taken to use the latest edition. In the following pages an attempt is made to give all the essential rules, and in many cases the reasons therefor, in a form that is less technical and perhaps more easily understood by the beginner, than that in the pamphlet of the National Board.

GENERAL INFORMATION—SECTION A

Buildings vary greatly in their adaptability to sprinkler protection and some buildings require a great many structural changes before they can become good sprinklered risks. The fundamental idea to be borne in mind is that sprinklers should be so located throughout a building that there is no unprotected place, however unexpected, where a fire can start. In other words, no matter where a fire starts there must be one or more sprinklers so located in relation to that particular point that the heat rising from the fire will open a head and allow the water that issues therefrom to strike the seat of the fire. Furthermore, there should be no direction

that the fire could spread in which it will not encounter other sprinklers to stop its progress.

It is evident therefore that sheathing, resulting as it does in hollow walls and floors, in which it is not practical to place sprinklers, is very undesirable from the standpoint of sprinkler protection; for should a fire work into such a hollow space it might spread for a considerable distance without opening sprinklers or without coming within the radius of the water thrown by them. Such sheathing should therefore be removed whenever possible, and if this is not done, the concealed spaces should be stopped off at intervals with tight fire stops designed to stop the spread of fire in any direction. These stops should be preferably of brick or other non-combustible material, but wood can be used if it is made sufficiently thick and is fitted in so tightly that no fire can work around the edges. In hollow ceilings the stops should be placed about every 30 feet, and in walls, at each floor level.

In a similar way large hanging shelves, wide benches, and numerous partitions are undesirable as they all tend to prevent the proper distribution of water from sprinklers. Highly inflammable sheathing, like cloth and paper, allows fire to spread rapidly along the surface and is detrimental to good sprinkler protection because it may cause the opening of many more heads than would otherwise occur.

Pitch roofs, leaving low studded or concealed spaces at the eaves, are undesirable as the heat from the fire tends to flow toward the peak and to open sprinklers at some distance from the flames. Such places are also very apt to become filled with storage that will obstruct the proper distribution of the water, and they are usually very inaccessible to hose streams from the outside.

Unprotected openings in floors are also bad features

as they tend to augment draughts from floor to floor, thus allowing the fire to spread quickly and also to prevent the banking up of heat around the sprinklers which is so necessary for their prompt operation. Such openings should be stopped off or enclosed in a standard manner. If for any reason this is impractical, curtain boards extending 12 to 18 inches below the ceiling around the opening offer an effectual means of banking up the heat in case of fire.

All floors should be made tight so that fire will not readily spread through any cracks and so that water from sprinklers will not leak rapidly through to the floors below. All sheathing that remains on the walls or ceilings should be made perfectly tight so as to retard the spread of fire into the concealed spaces which it forms. All floor openings, such as stairs, elevators, dumb waiters, etc., should be tightly enclosed or stopped off with traps. Partitions should be cut down or if possible should be entirely removed. Benches should be set away from walls at least 3 inches so that the water can wet both sides and thus prevent a fire underneath from spreading.

The rule requiring 24 inches clear space between sprinkler heads and any storage is of particular importance in order to give the sprinklers sufficient space in which to operate effectively. This is a matter that is frequently forgotten or disregarded by the property owner and has to be carefully looked out for at inspections.

High-studded rooms, like auditoriums of theatres, are not adapted to good sprinkler protection for the reason that the heat rising from a fire is liable to be deflected to one side by draughts and thus open sprinklers that are so far away that the water they discharge cannot reach the fire. Then again the heads do not open as promptly under these conditions, because the

heat is dissipated to a greater extent and because there is a much larger amount of air to be heated before the melting point of the solder is reached.

There have been many very disastrous fires in saw mills using logs as raw stock, largely due to the fact that these buildings are not well adapted to sprinkler control. They are usually high studded and with open ends so that the draught conditions, especially if there is any wind blowing, are very severe.

Very large areas cannot be as well protected by sprinklers as those of moderate or small size as there is more apt to be draughts which will carry the heat away from the sprinklers above. This means that more sprinklers will have to open to control the fire and thus more damage will result. For this reason fire walls or non-combustible partitions dividing the area into smaller sections are very desirable in such buildings. While no exact figure can be given, it is generally considered good practice to keep the floor area of fire sections down to 10,000 square feet or less. It is also very essential to partition off any unsprinklered section, such as a vacant part of a basement by a fireproof or solid plank partition, so as to prevent a fire from getting headway where there are no sprinklers to control it. For the same reason when an unsprinklered building adjoins or communicates with one equipped with sprinklers there should be a standard fire wall between them. Where there is a space between the buildings, the sprinklered building should be protected by standard shutters, wired glass windows or open sprinklers.

Curtain boards can be used to advantage in large area sections where solid walls cannot be used to cut up the area; as, for instance, in electric car barns. These should be preferably non-combustible and should extend from the ceiling a distance of at least 6 inches, preferably 1 to 2 feet below the sprinkler heads. These tend to

prevent draughts at the ceiling level and to pocket or bank up the heat where it is needed.

In certain classes of risks sprinklers are at a permanent disadvantage on account of the nature of the processes or the stock used. These include risks where the stock is stored in deep hollow piles, such as empty barrels in tiers, and cold storage plants where the piping and heads are kept at a very low temperature; also risks using large amounts of benzine, especially in exposed tanks; and those using celluloid or explosives, where a rapid flash fire is possible.

Most important of all is the rule stating that sprinklers should be installed in all parts of a plant. Mr. Edward Atkinson once said that if we could only tell where a fire was going to start we could place one sprinkler over that spot and that would be sufficient. Unfortunately this is a fact that we never can determine unless perchance we are connected with the "Arson Trust." Fires start in the most unexpected places as will be seen in the following illustrations.

A serious fire in Berlin, N. H., about 25 years ago started at the main water wheel bearing in the sub-basement of a saw mill. It was a dark wet spot and the keen eyes of the inspectors would hardly have looked for trouble there even if they had succeeded in reaching such an inaccessible place. Yet this was where the fire started and as there were no sprinklers there it soon gained such headway that the entire plant was destroyed.

In Norwich, Conn., one building of a large group was built directly over a raceway. The ground floor was 3 or 4 feet above the water and was open to the weather. No one had ever suggested placing sprinklers over running water, yet in this case they were needed. Trouble developed in an oil pipe in the yard and a lot of oil escaped into the raceway. This oil became

ignited and flowing under the building set it on fire causing a heavy loss.

It was formerly thought unnecessary to install sprinklers in one-story beam houses and tan yards connected with tanneries. These contain only vats of water and wet hides where one might think a fire could not start. In Peabody, Mass., a few years ago a serious fire occurred in one of these beam houses caused by working men's overalls, or burlap, being carelessly thrown behind steam pipes. After that experience, the beam house was equipped and it is now quite customary to equip all buildings of this character.

It is clear, therefore, that all parts of a plant should be equipped before the sprinkler protection can be considered good. The only important exceptions to this rule are the following: fireproof sections containing wet work or no readily combustible contents; low vacant basements that are tightly partitioned off and not used for any purpose, even for non-combustible storage; fireproof stair towers except at the top; fireproof dynamo rooms containing nothing but electrical machinery.

LOCATION OF AUTOMATIC SPRINKLERS — SECTION B

Heads should point up on the pipe except where construction or occupancy of the room makes it preferable to have them point down. Most of the older heads were constructed so that they had to point down but it was found that when in this position they were more apt to be injured by blows than when they were above the pipe and were protected by the piping below. Furthermore, such a system could not be readily drained and was therefore not suitable for dry-pipe installations. A pendent head was more liable to be clogged with sediment and was also somewhat less sensitive as the solder joint was further from the ceiling. For these

reasons the rules now prohibit pendent sprinklers except in special cases.

As the bulk of the water is thrown in an umbrella-shaped spray from the head it is necessary to have the deflector parallel to the ceiling or surface under which the head is located in order to give the best protection. Under peak roofs or sloping stairs this requires turning the head so that the deflector is parallel to the slope of the roof, ceiling or stairs. The line which comes directly in the peak should, however, point up as it cannot be parallel to both the surfaces that it is to protect.

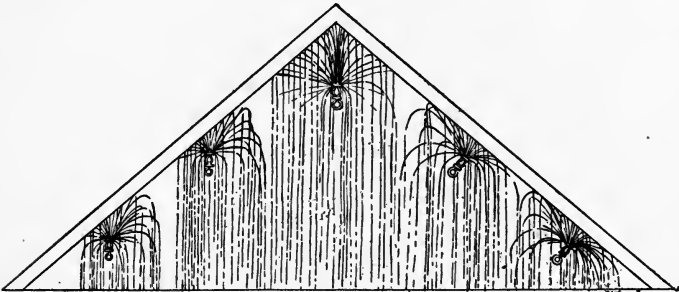

SKETCH OF PEAKED ROOF SHOWING DISTRIBUTION OF SPRINKLERS IN AN UPRIGHT POSITION (ON LEFT) AND THOSE WITH DEFLECTORS PARALLEL TO SLOPE (ON RIGHT).

The distance of the sprinkler from the ceiling is also important. If it is too close the spray will not cover a large enough area of the ceiling and is unduly obstructed by joists or beams. If it is too far away, not enough of the water will reach the ceiling and the sensitiveness will be lessened. The rules state that the deflector shall be between 3 and 10 inches from the ceiling or bottom of joists, preferably 6 to 8 inches. If the ceiling is of fireproof construction a 50 per cent greater distance is allowed as in this case it is not important that the ceiling be sprayed.

It is of particular importance that sprinklers should not be placed too close to a joisted ceiling as the obstruction of the joists to the spread of water greatly affects the distribution in the direction across joists. There is a great temptation to do this in dry systems, especially the end heads on a line, in order to get good drainage.

There are many concealed spaces like belt boxes, gear boxes, chutes, cupboards, etc., which should have sprinklers inside unless the tops can be removed. Cloth or paper tops are frequently allowed instead of placing sprinklers inside, on the theory that if a fire starts in such a place, the top will quickly burn off so that the ceiling sprinklers outside can control the fire.

Sprinklers should be placed beneath large shelves or tables, especially if there be shafting or any similar hazard there. No exact rule can be given for the limit of width which calls for sprinklers but in most cases the line should be drawn at about 4 feet. Benches or shelves of a less width need not usually be equipped, although care should be taken that they are set clear from walls or partitions. Where there is a wide bench with shafting under the center it is often possible to get good protection by taking out the boards in the center of the bench, leaving an open strip 8 inches or more wide over the shafting.

The question frequently arises whether sprinklers should be installed in dynamo and switchboard rooms. The owner frequently objects to sprinklers in such places, as water on electrical machinery is apt to do more damage than fire, and, in addition, to endanger life. If the room is fireproof or is small and thoroughly cut off it is generally desirable to omit sprinklers. In other cases it is better practice to install them though permission is frequently given to keep the water shut off by a well-located, quick-opening valve that can be opened without delay in case of need.

In vertical shafts of combustible material, such as wood-enclosed elevators or chutes, it is necessary to install heads at intervals along the vertical walls as well as at the top. Fire travels very rapidly up shafts of this kind and if sprinklers were placed at the top only, they would not open promptly enough to prevent the spread of fire; neither would they throw enough water to thoroughly wet all walls for their entire length. Therefore heads are called for at each floor level where practicable and in any event at least one for every 200 square feet of inflammable surface.

MISCELLANEOUS RULES—SECTION K

Circulation in Pipes. Sprinkler pipes should be used for sprinkler service only. The circulation of water in pipes causes corrosion and may bring in sediment. It may also cause condensation of moisture on the pipes which in many classes of risks will result in considerable damage to stock. There is a growing tendency on the part of water departments to require meters in sprinkler connections on account of the illegal use of water from these pipes. This is undesirable on account of the cost of the meters and the possible obstruction to the pipes. By strictly enforcing the rule that sprinkler pipes be used for no other purpose and by metering the domestic service connections, there would be less cause for complaint from the water departments.

Service Connections. Where the domestic service pipe is small, say 1 inch or less, and the street connection is larger than the riser it supplies, there is no particular objection to taking the domestic service pipe off the fire service connection back of all valves provided there is a valve and meter on the domestic service connection close to the main pipe.

Painting and Bronzing. It is often desirable to paint or bronze sprinkler pipes both to prevent corrosion and

to improve the appearance of the piping. There is no objection to doing this providing the moving parts of the sprinklers are not coated. Paint of any kind on the soldered portions will render them less sensitive and may cause the moving parts to stick. In case a ceiling is to be painted or whitewashed with a spraying machine the sprinkler heads should be protected during the process. This can easily be done by tying a small paper bag over each head, care being taken to remove these bags as soon as possible.

Piling of Stock. Sprinklers should have a clear space of at least 2 feet in which to operate. That is, all storage should be kept at least 18 inches below sprinkler pipes, assuming that the piping will be about 6 inches below the ceiling. In city buildings or others where floor space is particularly valuable, this means a loss of storage space which may be worth a good deal of money. This feature should be fully understood before an equipment is installed so that when an inspector orders the storage lowered there can be no cause for complaint. In a like manner, stock so piled as to greatly obstruct distribution, such as on high wide racks, is undesirable, and special care must be taken in arranging sprinkler heads so as to give proper protection.

Hanging of Stock. The rules prohibit the hanging of stock, clothing, etc., on sprinkler pipes, both because of the obstruction to distribution which might result and on account of the danger of loosening or breaking the pipe supports.

Extra Sprinklers. The rules call for at least six extra sprinklers to be kept on hand at all times to replace any that may have been fused or injured. Where there are high-test heads in the equipment there should also be extra heads of all the different fusing points which might be needed. Extra heads should be kept in engine room, or some other well-known place so that

they can be quickly found when needed. Several persons connected with the plant, including watchman if there be one, should be instructed as to the location, and it is well to have this information posted on placards. The need of having extra sprinklers readily available was well illustrated by the Phelps Building fire in Springfield, Mass., in 1907, described under Fire Record.

Hand Hose. Hand hose is allowed to be connected to the sprinkler equipment under certain restrictions. Hose to be $1\frac{1}{2}$ inches and nozzle not larger than $\frac{1}{2}$ inch. Pipe nipple and hose valve to be 1 inch and hose to be connected to piping not smaller than $2\frac{1}{2}$ inches. It is self-evident that hose should never be connected to dry-pipe systems. The reason that $1\frac{1}{2}$ -inch hose is called for with 1-inch nipple is because 1 inch is the largest outlet that it is thought desirable to make to a sprinkler equipment on account of the possible loss of pressure that would result when the hose was in use. The friction loss in 1-inch linen hose is however considerable and $1\frac{1}{2}$ -inch hose is preferable on this account.

Hand hose installed as above specified is considered a very desirable form of protection and is, of course, very inexpensive. It is strongly recommended in hazardous rooms like picker and card rooms of cotton mills. Hose of 25-foot lengths located about every 40 feet down the length of a building is a desirable arrangement. Hand hose should, however, be used sparingly in case the primary water supply is weak.

SPACING OF AUTOMATIC SPRINKLERS—SECTION C

The spacing of sprinklers varies greatly according to the construction of the ceiling under which they are placed. In general, it may be said that they should be so located that no head will have to cover, under most conditions, over 80 square feet floor area and under no conditions more than 100 square feet. In no case

should the distance between heads exceed 12 feet, nor should the distance to walls or partitions exceed half the distance between the heads.

Under "mill" or plank and timber construction the lines should run in the center of the bay, and the heads should be from 8 to 12 feet apart depending upon the width of the bay. In narrow bays of 5 to 8 feet, heads can be 12 feet apart, and in bays 11 to 12 feet wide, heads should be 8 feet apart. For intermediate widths the spacing should be such that one head will not have to cover more than 100 feet. In bays wider than 12 feet, two lines are required, although where the width of bay is between 12 and $13\frac{1}{2}$ feet, good protection can often be secured by placing one and two lines alternately in the bays. Mill construction, strictly speaking, includes only widths of bays between 5 and 12 feet, but semi-mill and special forms of construction are frequently found with bays or spaces between supporting beams of greater or less amount than this. Where bays are less than 5 feet, good protection can be obtained by running the feed lines across timbers and placing a head in every other bay, staggered on alternate lines. Bays of less than 4 feet are usually treated as joisted construction.

Under plank and timber pocket construction, that is where cross beams cut the ceiling into squares and oblongs, special rulings should be made for each particular case. In general it is safe to consider each pocket as a short bay and space the heads accordingly, but in cases where this arrangement would give an excessive number of heads, good protection can generally be obtained by alternating one and two or two and three heads in a pocket.

Under open-joist construction the distance between heads should not exceed 8 feet across joists and 10 feet with joists. By "across joists" is meant the direction at right angles to the direction the joists run and

by "with joists" is meant the direction parallel to that of the joists. The requirement for a closer spacing across joists is due to the fact that fire travels much more readily along than across joists, and also to the fact that the water from the sprinklers is thrown further and more effectively in the direction parallel to the joists. For the same reason the rules require that the sprinklers be "staggered" across joists; that is the heads on one line should come half way between the heads on the adjoining line measured in a direction parallel to the joists. With this arrangement it is possible for a fire to spread along joists half way between the heads on one line, but when the next line is reached there will be a head directly in its path to stop further progress. In other words the staggering of the heads gives the fire a path only 4 feet wide in which it can travel along between joists without coming directly in contact with some sprinkler. Without staggered spacing this path would be 8 feet wide. This rule, which has been in effect since 1896, is a very important one and equipments installed under the previous rules which did not require staggered spacing cannot be considered as entirely satisfactory today.

In laying out an equipment under open joists it is better and usually cheaper to run the lines of pipe at right angles to the joists. The best method of procedure is as follows: First line, end head to be 4 feet from wall; second head, 8 feet from first; third, 8 feet from second, etc. Second line, first head, 2 feet from wall; second head, 6 feet from the first; third head, 8 feet from the second, etc. Third line, same as first and fourth line, same as second. In this way perfect staggering is obtained.

Where joists are supported by timbers forming bays, one line is allowed in a bay up to a width of $11\frac{1}{2}$ feet. It is customary to double this rule, that is to allow two

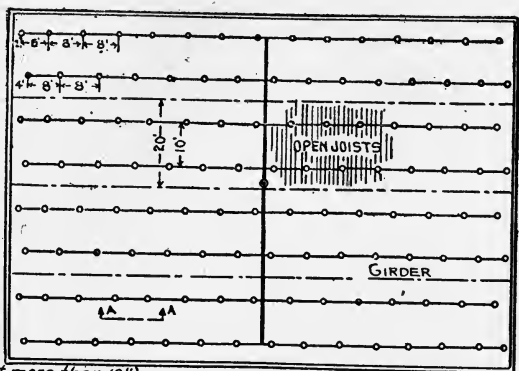

METHOD OF SPACING SPRINKLER HEADS UNDER OPEN JOIST CEILINGS IN BUILDINGS OF ORDINARY CONSTRUCTION
SPRINKLERS STAGGERED

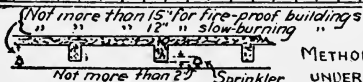
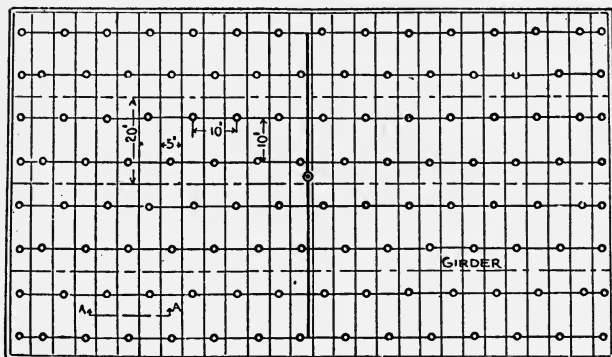

METHOD OF SPACING SPRINKLER HEADS UNDER CEILINGS OF SLOW-BURNING AND FIREPROOF CONSTRUCTION
BAYS 5 FT X 20 FT
SPRINKLERS STAGGERED IN ALTERNATE BAYS.

○ Indicates a sprinkler
● " " riser

SPRINKLER SPACING.

lines in widths up to 23 feet. In either case the heads should be placed sufficiently close on the lines so that no head will have to cover more than 80 square feet. In bays $11\frac{1}{2}$ to 13 feet wide, fairly good protection can often be obtained by alternating one and two lines in a bay. In cases where there are partitions running across joists it is impossible to strictly follow the rule that the distance from the head to a partition shall not exceed one-half the distance between heads, without installing an excessive number of heads. The rule is frequently modified by Underwriters having jurisdiction in this case.

Under smooth finish ceiling, such as lath and plaster or fireproof construction, heads can be placed 10 feet apart in each direction. Such ceilings are, however, often cut up by timbers or girders, in which case the heads should be placed with due reference to these obstructions.

Under pitch roofs fires are more difficult to control than under horizontal surfaces, and the rules are therefore somewhat more exacting. Where the slope is steep (one foot in three or over) a line is required in the peak and one within $3\frac{1}{2}$ feet of the eaves on each side. The intermediate lines to be not over 10 feet apart measured on a line parallel to the roof. Where conditions make it desirable, two lines not over $2\frac{1}{2}$ feet from the peak may be used instead of the line at the peak. In saw-tooth roofs the end sprinkler on branch line ought to be not over $2\frac{1}{2}$ feet from peak of saw tooth so as to properly protect the steep side of the saw-tooth which, unlike a side wall, is seldom or never vertical.

Under fireproof construction the spacing may be somewhat modified to suit conditions, bearing in mind that it is the contents rather than the building which should be protected and that under no conditions should a sprinkler on one line exceed 12 feet to a sprinkler on an adjoining line.

PIPE SIZES—SECTION D

The original pipe sizes for sprinkler equipments were undoubtedly the outgrowth of those used for perforated pipe systems. The most common schedule of pipe sizes in the early equipments was that designed by the Providence Steam and Gas Pipe Company. This schedule which was the standard for many years was as follows:

1-3-6 SCHEDULE

Pipe, inches.	Head.	Pipe, inches.	Head.
$\frac{3}{4}$	1	3	48
1	3	$3\frac{1}{2}$	78
$1\frac{1}{4}$	6	4	115
$1\frac{1}{2}$	10	5	150
2	18	6	200
$2\frac{1}{2}$	28		

It is generally known as the 1-3-6 or P.S. and G.P. schedule. There were, however, various other rules both for pipe sizes and spacing used in different parts of the country up to 1896. In that year the National Fire Protection Association was organized and one of the principal reasons for its formation was the demand for a standard set of rules for automatic sprinklers. The pipe sizes first adopted by the Association called for considerably larger pipes than were used in the 1-3-6 schedule, as it had been found by experiments and by actual practice that these caused too much friction loss under moderate and lightwater pressures. The 1896, or 1-2-4 schedule, was as follows:

1-2-4 SCHEDULE

Pipe, inches.	Head.	Pipe, inches.	Head.
$\frac{3}{4}$	1	3	48
1	2	$3\frac{1}{2}$	78
$1\frac{1}{4}$	4	4	110
$1\frac{1}{2}$	8	5	150
2	16	6	200
$2\frac{1}{2}$	28		

These rules limited the number of sprinklers on a branch line to 6 unless the sizes were increased beyond the 6th head to one size larger than the schedule specified. This was done because it was felt that even with these increased sizes there was some question whether the end head on a long line would receive enough water when all the other heads on the line were operating.

Meanwhile the Factory Mutual Insurance Companies had adopted a new schedule of sizes which was still larger. This schedule, known as the 1-2-3 schedule, was adopted by the National Fire Protection Association, and promulgated by the National Board of Fire Underwriters in 1905. Since then it has been the standard in all parts of the country and for all interests. This schedule, which does not limit the number of heads on a line, is as follows:

1-2-3 SCHEDULE

Pipe, inches.	Heads.	Pipe, inches.	Heads.
$\frac{3}{4}$	1	3	36
1	2	$3\frac{1}{2}$	55
$1\frac{1}{4}$	3	4	80
$1\frac{1}{2}$	5	5	140
2	10	6	200
$2\frac{1}{2}$	20		

The number of sprinklers on a given size pipe refers to the number on a floor of a fire section or building, as all equipments are installed upon the supposition that only one floor will be on fire at once. A fire that will open a large number of heads upon more than one floor is usually beyond the control of sprinklers. In other words the same size riser is allowed for an eight-story building as for a one-story building provided the number of heads on a floor is the same.

In the case of blind attics containing unprotected openings to the floor below it is frequently necessary to install the piping by running up offsets at each head from the piping below. In this case the system may be installed without increasing the pipe sizes except those under 3 inches in diameter.

CHAPTER VI

LAYOUT OF EQUIPMENTS

FEED MAINS AND RISERS—SECTION E

The best and usually the most economical method of arranging feed pipes to sprinklers is to have the riser near the center of the group of sprinklers that it supplies and to have the branch lines short. In the center central scheme, which is the most desirable one, the riser is near the center of the building, the main feed lines run lengthwise of the building, near the center, and the branch lines run across the short dimension of the building. In this case the cross lines cover only one-half of the short dimension of the building. In the side central scheme, which is perhaps the next best, the riser is near the center of one of the long sides of the room and the main-feed lines run lengthwise of the room but at one side. In this case the cross-feed lines run parallel to the short dimension of the building, but are twice as long as in the previous case. Another scheme of piping is shown in the sketch and explains itself. The only unapproved schemes are those in which the riser is located in the corner of the building thus giving end side or across end feed. In either case the friction loss is excessive as compared with the approved methods.

For small buildings this scheme of feed lines is of little importance and where there are less than 50 heads on a floor it need hardly be considered. It is a feature that usually takes care of itself, for it is more economical for the sprinkler contractor to lay out the equipment in an approved way because it takes a smaller amount of the

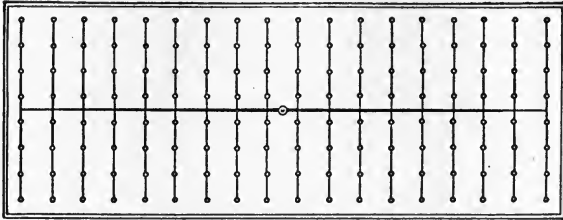

Center Central Feed to Automatic Sprinklers

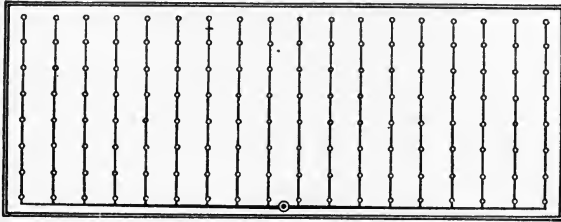

Side Central Feed to Automatic Sprinklers.

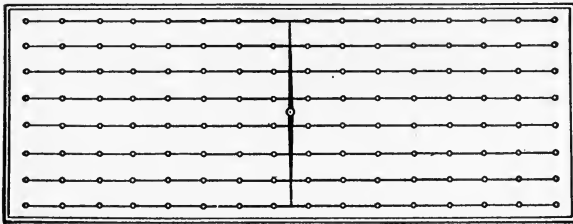

Across Center Feed to Automatic Sprinklers
 ○ shows a Sprinkler . ● shows Riser.

LAYOUTS OF FEED MAINS AND RISERS.

larger pipes. It is, however, always desirable to arrange the piping so that there will not be over 8 heads on a branch line.

There should be a separate riser for each building and for each fire section in a building. It should be of ample size to supply the maximum number of heads on any floor and preferably a little larger so as to allow for additional heads which may be needed in the future due to structural changes. Stair and other similar towers should be piped as though they were all one floor. That is, the sizes, beginning at the top, should be increased as each head is added. A fire in such a place is liable to open the heads on all floors.

Except where tanks on the building are the only automatic supplies to the system, the supplies should feed in at the bottom of the riser. This is required so that the valves, including gate valve and alarm valve or dry valve, can be conveniently located at the lower level and so that one gate valve may be arranged to shut off all the supplies from the system.

Great care should be taken to thoroughly fasten together the cast- and wrought-iron pipe as this is apt to be one of the weakest parts of the system. If wrought-iron pipe is connected to bell and spigot cast iron the joint should be strapped with heavy metal straps clamped to the pipe. If possible flanged and spigot pipe should be used as with this a stronger joint can be obtained.

It is desirable to have the underground pipe laid to the base of the riser so that there will be but one elbow and so that the riser will be well supported.

VALVES AND FITTINGS—SECTION F

Shut-off valves are needed in sprinkler systems to shut off the water in the pipes after a fire has occurred, or in case of leakage or repairs. The only type of valve approved is the so-called outside screw and yoke gate

valve. In this valve there is a free water way when the valve is open and therefore practically no friction loss. The outside screw and yoke feature consists of a rising stem threaded on the outside which shows by its position the condition of the valve. When the valve is closed the stem is down and but little of it is visible. When the valve is open the stem is exposed and shows this fact plainly from a considerable distance. This is the simplest and best form of indicator yet devised and was therefore adopted as a standard.

The older types of indicators consisted of sliding or swinging targets attached to the valve stem usually by a threaded nut. These were somewhat unreliable as they could in many cases be set in the wrong position and were quite liable to get out of order. While many of these indicator valves are still found in old equipments, they have not been installed to any extent since the present requirements went into effect some 20 years ago.

Underground valves if not located in pits should be post valves of an approved indicator pattern. These consist of a hollow iron post attached to the valve, extending about 3 feet above ground with the spindle extending up through the post to a wrench head located at the top. This can be operated either by a movable wrench or a permanently attached hand wheel. The post is arranged with a frost-proof casing so that it will not be thrown out of place by frost, and a target indicator is attached which is usually covered by a small glass plate.

In fenced yards or other locations where it is not liable to be tampered with, the permanent hand wheel is advised as it is always ready for use and gives a means of sealing or strapping open the valve. In public streets or other exposed places a removable wrench is preferable.

Check valves are devices which work automatically, allowing water to flow through in one direction but not in the other. Several styles are on the market, but the simplest and best type for sprinkler use is the straightway swing type. In this type there is a clapper, which is a disc hung from a pivot in such a way that in its normal position it rests against a valve seat placed at a slight angle with the vertical. The water coming in one direction pushes the valve against the seat making a tight joint and preventing any flow in that direction. In the other direction the water tends to swing the valve off the seat and allow a flow. If the flowage is sufficient, the valve is swung into a practically horizontal position, in which case it causes but little obstruction to the pipe in which it is placed. The clapper or valve should be of brass and have a good clearance so that there will be no danger of corrosion or sticking. (See rules of National Fire Protection Association for Hydrants and Valves.)

When two sources of supply feed one sprinkler system it is necessary to have a check valve in each so that the water will not back up or flow from one source back through the other supply. Without a check valve the water from a supply of heavy pressure, such as a waterworks system, would flow back through the pipes of a supply of lighter pressure, such as a gravity tank, and overflow the latter. Again if the pressure in the waterworks mains should drop for any reason, — such as a break, — to below the tank pressure, the tank would be drained through the break unless the flowage in that direction was safeguarded by a check valve.

The rules, therefore, require that a gate valve and a check valve be provided on each source of supply, the gate valve to enable one source to be shut off independently of the other source, for repairs or testing purposes, and the check valve to prevent one supply

from backing up into the other. The gate valve should be located as close to the source of supply as practicable so that as much of the piping as possible may be shut off. Otherwise it might be difficult to make repairs in case of a break at some point back of the gate valve. In the case of a tank supply, this would mean that the gate valve should be placed right under the tank or as near the tank as would be readily accessible; while in the case of a waterworks connection, the valve should be as near the street main as possible. In practice gate valves are located close to pressure tanks but not always close to gravity tanks. If the tank is in a tower, the valve can be located close to the tank, but if it is on a trestle over a building, the gate valve can be more conveniently located in the building on the top floor. If the tank is on a detached trestle the gate valve is usually located underground at the foot of the trestle and a post-indicator valve is used for the purpose.

The check valve should be located as far from the source of supply as possible so that in case of a break as much of the piping as possible will be protected. If, for example, the check is located close to a tank, a break in the tank pipe anywhere between the check valve and the connection with the system would allow both sources of supply to waste away through the break; while if the check is located close to the connection to the system, all of the piping between that point and the tank is protected by the check so that in case of a break only the tank supply will be lost. In most cases, of course, the gate valve would be closed before much water had been lost, but occasionally the leak would not be discovered in time to do this; while if the break occurred during a fire the consequences might be very serious.

It is desirable when possible to arrange the check valve so that it can be examined or repaired without

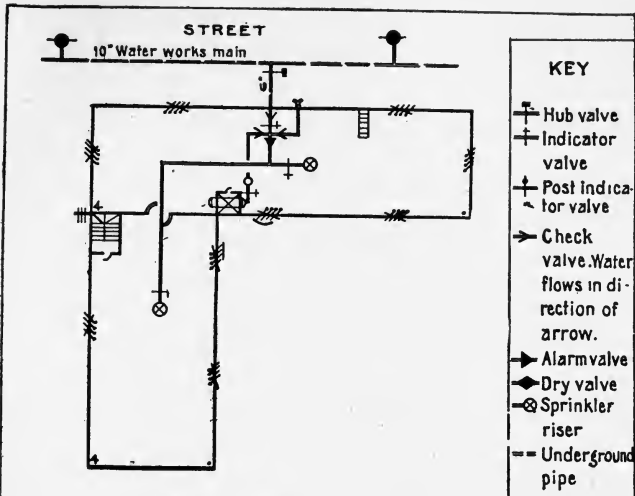

PIPE SCHEME 1
City Plant with water works pressure tank and steamer connection.

- KEY**
- ⊕ Hub valve
 - ⊕ Indicator valve
 - ⊕ Post indicator valve
 - ➔ Check valve. Water flows in direction of arrow.
 - ➔ Alarm valve
 - ◆ Dry valve
 - ⊗ Sprinkler riser
 - - - Underground pipe
 - Exposed pipe
 - ⊕ Three way private hydr. with valves on outlets
 - Two way public hydr.
 - Standard fire door
 - Hose house
 - Pit
 - ▨ Boiler
 - ⊠ Chimney
 - ⊕ Steamer connection
 - ▭ Pressure tank
 - Gravity tank

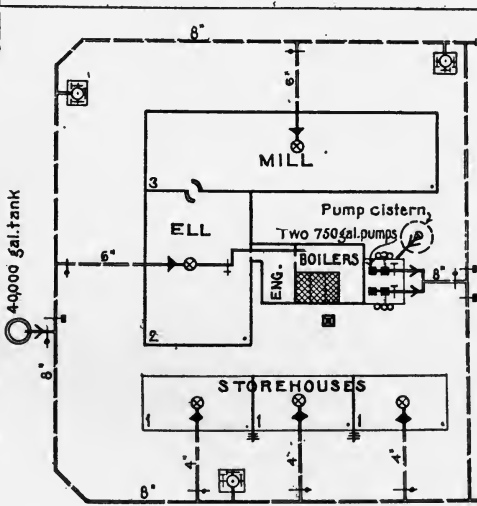

PIPE SCHEME 2
Country Plant with gravity tank and steam pumps. 8" loop containing repair valves and private hydrs.

shutting off the other supply or, in case of a tank, without draining the tank. For this reason it is desirable to have a gate valve on each side of a check valve when located on waterworks, reservoir or large tank supplies. In connections from waterworks systems there is usually a gate valve put in by the water company and located on the connection close to the main. This, while not readily accessible, can be used in case of repairs and therefore does away with the need of one of these private gate valves. In supplies from pumps, only one gate valve is usually necessary, for unless the pump is automatic, there is ordinarily no pressure on the pump side of the check.

All gate valves should be located where easily visible and readily accessible; permanent ladders and platforms should be provided where necessary. Check valves should, where possible, be located so as to be accessible. When underground, it is desirable to locate them in pits, but this is not always practicable on account of the danger of freezing or of flooding the pit and sometimes on account of the expense. In case there is no pit, a permanent marker of stone or iron should be installed to show the exact location of the check.

When a pump is not in a fireproof pump house but is subject to damage by falling walls, the check valve on the pump discharge should be underground and a post valve should be located in the pipe just beyond the check and at a safe distance from the building.

The ideal arrangement for most classes of risks is to feed a sprinkler system through an underground pipe containing a post valve located at a safe distance from the building but with no valves inside of the building. This makes it possible to shut off or turn on the supplies without going into the building. Occasionally in case of a serious fire the sprinkler piping will become so badly broken that it is desirable to shut off the con-

nection and utilize the entire supply for hose streams. Without a post valve this would usually not be possible as the heat would prevent close approach to the inside valve. Again, in case of repairs, post valve control is sometimes of vital importance. A fire at the Armstrong Cork Co. a few years ago brought out this point very forcibly. There was an inside and outside valve on the sprinkler connection to one of the buildings but during repairs the inside valve was closed. A fire occurred and the inside valve could not be reached on account of the heat. As a result a serious fire occurred and the building was nearly destroyed. Had the post valve been used during repairs the water could have been turned on after the fire was discovered.

As a general proposition the fewer valves the better. A multiplicity of valves makes a complicated system and gives more chance for a valve being closed by mistake. In risks where the contents are very susceptible to water damage, inside valves may be desirable in addition to post valves because in case of emergency they can usually be closed more quickly. In most risks the single post valve located outside the building is sufficient.

The post valve should, whenever possible, be located at a safe distance from the building. By this is meant a distance that will not permit damage by falling walls and that will not be too hot to approach in case of fire. For the average 3- or 4-story building this distance should be 40 to 50 feet while for small 1-story buildings it might be as close as 20 feet.

In city risks post valves are generally out of the question, for if installed they would have to be located on a sidewalk where they would be quite close to the building and where they might readily be tampered with. It is possible in some cases to loop the pipe back across the street and locate the valve on the opposite

sidewalk, but this is rather expensive and causes additional friction loss. It is therefore usually necessary in such risks to have the controlling valves inside the building. The best arrangement of valves inside a building will vary greatly according to circumstances and but few general rules can be laid down. Where possible it is desirable to locate all controlling valves, alarm valves, dry valves, etc., together in a fireproof room accessible from outside.

Occasionally, shut-off valves are located on each floor of a building, but, as a general rule, they are not desirable as they make the system more complicated and give further chance for trouble from closed valves. In department stores, or other risks where the care of fire appliances is first class and where any delay in shutting off the water would cause a heavy water loss on susceptible stock, floor valves are recommended. A valve is placed close to the riser shutting off all the sprinklers on the floor, and it should be made readily accessible by a permanent ladder.

Long-bend fittings are now required on all feed lines. They cost a little more than short bend fittings, but cause much less friction loss and are therefore very desirable. All fittings should have standard threads. Extra heavy fittings should be used where the pressure exceeds 150 pounds.

Hangers. The rules require either U-type hangers made of round wrought iron or malleable cast iron, ring clips or approved adjustable hangers. Flat U-hangers are allowed when the metal is $\frac{3}{16}$ -inch thick or more.

The size of screws and the size of hangers for different sizes of pipes are specified in detail in the rules. Drive screws are allowed only in a horizontal position as in the side of a beam.

Hangers should be located about 12 inches from the

sprinkler heads so as not to obstruct distribution, except round hangers which may be located as close as 3 inches under mill or fireproof construction.

Two hangers are required for $\frac{3}{4}$ -inch pipe at the end of lines where such pipe is over 6 feet long.

For concrete construction cast-iron inserts should be used or hangers should be attached directly to the steel beams. In buildings already constructed expansion bolts satisfactory to the Inspection Department having jurisdiction may be used, preferably in a horizontal position.

Test Pipes. A test pipe is required at the top of the riser on all wet-pipe systems. This is installed so that a test can be made to see that the water is on the system and under full pressure. This should be of a capacity equivalent to one sprinkler head so that in testing a system in which there is an alarm valve, the test will show whether the alarm valve is adjusted to operate with one head open. To this end a $\frac{3}{4}$ -inch pipe should be used with as few angles as possible and a $\frac{1}{2}$ -inch brass bushing should be attached at the end. An open sprinkler head with the deflector removed can be used for this purpose.

Half-inch pipe has been generally used in the past for this purpose, but is unsatisfactory in testing an alarm valve, especially if it contains many angles, as it will discharge considerably less than one sprinkler head. The test pipe is connected to the top of the riser so as to prevent sediment and corrosion being drawn into the branch lines when a test is made. The writer has seen a case in a town where the water was very muddy at certain times in the year, where the frequent use of a test pipe attached to a branch line finally filled the line completely with mud.

Drip Pipes. Arrangements should be made to thoroughly drain all parts of a sprinkler system so that when the water is drawn off for repairs or in case of shut down

there would be no water remaining in the pipes which might cause trouble by freezing. To this end all pipes should be pitched not less than $\frac{1}{4}$ inch in 10 feet, and all branch lines should drain back to feed lines and risers. When possible one drip pipe should be arranged to drain the entire system. This should be located at the base of the riser just above the main controlling valve, or in cases where the system is controlled by a post valve, at the lowest practical point in the system. It should be 2 inches in diameter and should extend outside of the building or to some point where the flow of water will do no damage.

In some city risks it is necessary to connect drip valves to the sewer but this is not recommended as it frequently prevents accurate tests and occasionally causes trouble by back pressure from the sewer. In some cities a section of glass is required in the drip pipe when it runs direct to a sewer, so that in case the drip valve should leak, this fact could be readily ascertained. When this is done great care should be taken to prevent a possible blow-out or breaking of the glass as this might result in heavy water damage. A few systems have been installed with indirect connection to the sewer; that is the drain is run to a blind well which is connected to the sewer. This is undesirable because any clogging of the pipe between the blind well and the sewer would be hard to determine on inspection and might cause the overflowing of the blind well on test.

When the drip pipe extends out of doors it should be fitted with a hood or turned-down elbow to prevent clogging with ice. When it extends under a building, care should be taken to so locate it that the discharge of water will do no damage. This is especially important in cases where a riser comes up through an unheated basement and is boxed to prevent freezing. If the

drip pipe discharges too close to the boxing it is liable to wash away the earth from the pipe below the boxing and allow it to freeze.

Pressure Gages. Standard $4\frac{1}{2}$ -inch dial spring-pressure gages are required on all systems in the following places:

Discharge pipe from each supply.

Above and below each alarm valve.

Above and below each dry valve.

At air pump supplying pressure tank.

At pressure tank.

At each independent pipe from air supply to dry-pipe system.

Gages to be located in a suitable and convenient place where not subject to freezing. A controlling cock with square head to be located on each gage connection; also a plugged tee or pet cock between each gage and cock.

The gages are required so that the water or air pressure can be readily noted at any time, thus giving a means of discovering closed valves or clogged pipes. The plugged tee or pet cock is installed so as to allow for putting on another gage for purposes of comparison and to allow drawing the pressure off the permanent gage to see that the needle comes back to zero.

Drip valves and pressure gages properly arranged are of great value to inspectors in making tests on water supplies, and without them it is frequently impossible to determine accurately the condition of the supply. The exact location of the gage is of great importance for if it is located on or close to the drip pipe, the suction caused by the flowage of water past the gage connection is liable to make the reading much too low. Care should be taken therefore to locate the gage on the main riser and where possible at least a foot above the drain pipe. The method of making the test will be described in the chapter on maintenance.

Protection Against Freezing. In unheated basements or other places where pipes cannot be buried below frost line, they should be thoroughly protected against freezing in some other way. Pipes running above ground from one building to another can often be boxed with a steam pipe inside of the boxing. This is a satisfactory arrangement provided the boxing is tight and that adequate steam pressure is constantly

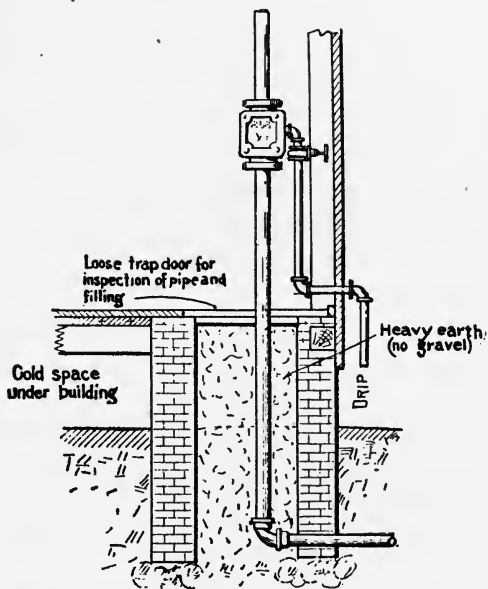

METHOD OF PROTECTING SPRINKLER PIPE IN UNHEATED BASEMENT
BY BRICK PIT FILLED WITH EARTH.

kept up in cold weather. Where this is not practical, a triple frost-proof boxing with air spaces, such as is called for in the rules for protecting discharge pipes from gravity tanks, can be installed. (See rules for Gravity Tanks.)

A riser coming up through an unheated basement can be protected by enclosing it in a brick, concrete or

wooden well extending from below frost line to the ceiling of the basement. The top can be left open so that warm air will circulate or steam pipes can be installed inside. Another method is to put in triple boxing, as mentioned above, running it below frost line. In some cases it can be surrounded by sufficient earth to make it safe. A thickness of three feet on all sides extending up to the under side of the floor should, in most cases, be enough. In a partially heated basement less protection may be necessary but it is desirable to be on the safe side.

Water Supplies — Section I

The water supplies commonly used are:

1. Waterworks.
2. Gravity tanks or reservoirs.
3. Pressure tanks.
4. Steam pumps.
5. Rotary pumps.
6. Centrifugal pumps.

In addition to the above, steamer connections are occasionally installed although they can seldom be considered as an additional supply.

In England the hydraulic injector is frequently used although its use is apparently limited to that country. The principle on which it operates is similar to that of any injector; namely, heavy pressure with small volume is used to raise the pressure in a supply of comparatively low pressure and large volume. The high-pressure source is the hydraulic mains which are quite common in the larger cities of England. They were installed for the transmission of power before the advent of electricity and were used to operate elevators and similar devices. The mains are small in size but carry water under a pressure of from 600 to 700 pounds per square

inch. A small jet of water under this pressure is used to induce a higher pressure in a connection from the regular waterworks supply, which is usually under as low a pressure as 20 to 30 pounds. The exact pressure can be accurately regulated and is controlled by an automatic attachment.

For standard protection two independent water supplies are necessary so that if anything happens to one supply there will be another one to fall back upon. In the case of town water, there is a chance it will be shut off on account of breaks in the mains, for making new connections for laying new mains, for cleaning reservoirs, etc. In the case of tanks they have to be occasionally drained for painting, cleaning and repairs. Pumps are particularly liable to be out of commission on account of repairs.

Another reason for the double supply is that it gives additional water in case of a large fire. Many waterworks systems are of insufficient capacity to give more than a few hundred gallons of water per minute without causing an undesirable drop in pressure. Most gravity tanks are not large enough or of sufficient elevation to give good hose streams for any length of time. In either of these cases a good pump would be a very desirable secondary supply as it would furnish a large supply of water under a heavy pressure in case the primary supply became overtaxed. The rules require that one of the supplies be automatic and that one be capable of furnishing water under heavy pressure.

One or more of the supplies should be capable of giving a pressure of at least 25 pounds on the highest sprinklers. The value of a supply is not to be judged, however, entirely by the static pressure. There should be sufficient capacity so that under a moderate flow there will not be an excessive drop in pressure. An excessive drop in pressure is difficult to define but in a

general way it might be said that it should not exceed 25 per cent with a 2-inch drip pipe wide open.

Waterworks Systems. In large cities, where there is a water works supply of heavy pressure and where the mains are of large size, and are well gridironed, a connection from the public mains with no secondary supply may generally be considered satisfactory for good sprinkler protection. In addition to the above, the water system should be under good management so that the chance of shutting off any particular section for repairs will be small. Where a connection can be made from two different street mains, so arranged with valves at the intersection of streets that it would not be necessary to shut off both streets for repairs, even better protection can be secured. While this cannot be considered the equivalent of two independent supplies it is certainly much better than one. Such an arrangement is frequently better than two supplies as found in some country risks which have to depend upon the limited supply furnished by tanks and pumps.

Connections from street mains to sprinkler risers should be at least as large as the risers they supply. Such a connection is usually cast iron while the riser is wrought iron. It is more liable to become clogged with sediment than is the riser and in the course of years this and corrosion may have considerable effect upon its capacity. For this reason it is desirable to use pipe of at least 6-inch diameter, although if the building is so small as to require not over a 4-inch riser and the distance to the street main is short, a 4-inch pipe may be satisfactory.

In order to constitute a standard water supply, a waterworks system should give at least 25 pounds pressure, at all times, on the highest line of sprinklers. The street main should be at least 6 inches in diameter and preferably fed from both directions. Street mains

fed one way, or in other words running to a dead end, are undesirable both from the fact that the supply of water is not as good and because trouble from water hammer is much more likely to occur. Water hammer is due to the sudden stopping of the flowage in a pipe and the larger the flow in proportion to the size of the pipe the worse is the effect of the hammer. Hydraulic elevators and the filling of locomotives cause a heavy flow for a short time and are particularly liable to cause water hammer in the mains from which they are supplied. When such connections are made with street mains running to a dead end there is almost sure to be trouble.

Water hammer may affect a sprinkler system by operating alarm valves or dry valves and occasionally by actually breaking pipes or sprinkler heads. Modern sprinklers are seldom affected by water hammer, but it is not uncommon to have old types of heads set leaking from this cause. There is no very effectual remedy for this trouble except possibly by extending the street main so as to do away with the dead end. In the case of a railroad filling pipe the trouble can often be obviated, or at least lessened, by putting in a slow-moving valve so that the water cannot be shut off too quickly. Relief valves connected to the system are also of some value although the impulse is often so quick that the valve does not have time to operate.

While street mains smaller than 6-inch diameter cannot be considered as affording a standard water supply, yet where the plant does not require a larger riser than 4 inches and where the main is fed both ways or where the distance to a larger main is short, such a supply may give very fair protection. Tests should be made to determine the actual efficiency of any such supply.

Meters. The rules state that no meters or pressure-regulating valves should be installed on sprinkler con-

nections without special consent. Pressure regulators are seldom necessary but it is not uncommon for a water department to insist on meters. There is a growing tendency on the part of water departments to call for meters and while they are undesirable from a fire protection standpoint, their importance from a waterworks point of view should not be overlooked. The demand for their introduction has been due almost entirely to the misuse of water from sprinkler connections. If all domestic service connections were metered and kept separate from fire service connections there should be but little need of meters on the latter. There are, however, cases where, on account of the size of the yard system, there is liable to be considerable leakage from underground joints and occasional drawing of water from hydrants. Under these circumstances it is not unreasonable to ask for meters on the fire service connection. Where, however, there is no yard piping, the separation of the domestic service pipe and the installation of an alarm valve on the sprinkler connection would seem to be ample safeguard to prevent the misuse of water from the sprinkler connection.

In some cases, where additional protection was desired, small meters have been installed in the $\frac{1}{2}$ -inch pipe between the alarm valve and the alarm connections in order to give an indication of the amount of water that passes through the system.

Where a meter must be used, one of the detector type is desirable from a fire protection standpoint. Such a meter consists of a weighted check valve around which there is a small by-pass containing an ordinary meter. The weighted check valve is placed in the sprinkler connection and is of the same diameter as the pipe. For the 6-inch size the by-pass is about 3 inches in diameter. All small flows are taken care of by the by-pass and are measured on the ordinary meter. When more water

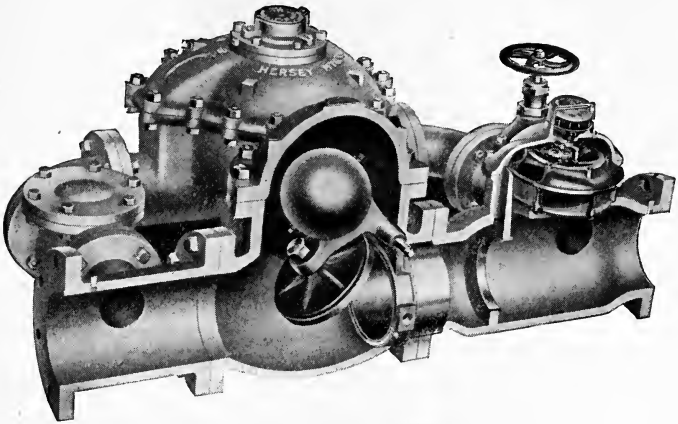

HERSEY DETECTOR METER.

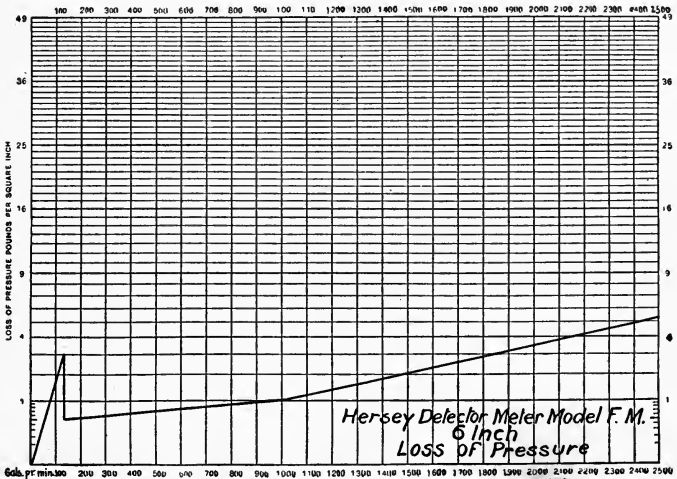

HERSEY DETECTOR METER.

Friction loss curve.

Horizontal spaces show gallons per minute.

Vertical spaces show loss of pressure in pounds per square inch.

is needed than can be supplied by the by-pass, the weighted check opens and the flow is recorded by a proportional meter located in the main pipe. The total flow is the sum of the readings of the two meters.

The Hersey Meter Co. is building this type of meter having friction loss as shown in preceding chart.

The Trident Protectus Meter, style I, made by the Neptune Meter Co. is approved for this use.

Gravity Tanks.

Note: For construction and installation rules, see pamphlet of National Board of Fire Underwriters on Tanks.

The capacity should never be less than 5000 gallons and preferably not less than 10,000 gallons. Where there is only one building to be supplied, a safe method for determining the proper size of tank, provided there is to be another supply of heavy pressure to back it up, is to figure the amount of water needed to supply one-quarter of the sprinklers on a floor for twenty minutes. This amounts to practically the same thing as taking 100 times the number of heads on a floor, assuming an average elevation of 25 feet for the water in the tank above the sprinklers. Thus, if there are 150 heads on a floor, a 15,000-gallon tank should be used. If the other supply is exceptionally good, a somewhat smaller tank might be used, but if the other supply is weak or if there is no other supply, a much larger tank would be desirable.

In hazardous risks where quick flash fires opening many heads are liable to occur, larger tanks are also desirable.

The elevation should be such as to give at least 15 pounds pressure on the top line of sprinklers. Here again the value of the other supply should be considered,

but 20 feet elevation for the bottom of the tank may be considered a minimum for good protection.

When the tank is to supply hydrants as well as sprinklers it should have a capacity of at least 40,000 gallons and an elevation of at least 100 feet above the ground. If the buildings are small and low these figures might be considerably modified but it cannot be considered good protection to use any tank for hydrant service unless it has a capacity of at least 30,000 gallons and an elevation above the highest building of at least 25 feet.

Ordinarily tanks should be used for sprinkler service only, but when the water is clear and without sediment it is not objectionable to make the tank somewhat larger than the size required for fire protection and to use the excess for domestic service. Thus if a 25,000-gallon tank is called for, a 30,000-gallon tank might be installed and the upper 5000 gallons used for domestic service or other purposes. This is done by running the domestic service pipe up to the proper elevation in the tank so that it can draw off only the upper sixth of the tank capacity. This arrangement tends to keep the tank full at all times, or at least full to the point where the domestic service pipe is connected, and it also tends to prevent freezing of the water. On the other hand the tank will act as a settling basin and any dirt or sediment in the water that is pumped into the tank will tend to settle to the bottom and to clog the sprinkler pipes.

Wood is generally used for the smaller sizes of tanks and steel for the larger sizes, say over 40,000 gallons. Both require careful maintenance, frequent painting, cleaning, etc. Concrete tanks are being used to some extent and are probably economical for sizes over 50,000 gallons. They have the advantage of being very permanent and requiring comparatively little expense for maintenance.

APPROXIMATE COST OF WOODEN TANKS COMPLETE ON STEEL
TRESTLE*

Including average cost of foundation, piping, painting, etc.

Size of tank, gallons.	Height of trestle in feet.						
	30	40	60	75	90	100	125
5,000	\$600	\$665	\$790	\$900	\$1050
10,000	875	950	1090	1160	1400	\$1525
15,000	950	1065	1300	1425	1675	1800	\$2140
20,000	1220	1350	1500	1700	1940	2100	2500
30,000	1600	1765	2000	2230	2465	2665	3090
40,000	2000	2150	2550	2850	3160	3425	3930
50,000	2250	2430	2820	3100	3510	3800	4450
75,000	2900	3030	3700	4000	4485	4775	5480
100,000	3450	3750	4500	4920	5360	5675	6430

APPROXIMATE COST OF STEEL TANKS COMPLETE ON STEEL
TRESTLES*

Including average cost of foundations and piping

Size of tank, gallons.	Height of trestle.				
	50 feet.	75 feet.	100 feet.	150 feet.	200 feet.
30,000	\$2200	\$2500	\$3,100	\$4,400	\$6,000
40,000	2400	2900	3,600	4,800	6,300
50,000	2800	3400	3,800	5,400	6,500
75,000	3500	4000	4,500	6,000	8,000
100,000	4200	4850	5,600	7,600	11,000
150,000	6000	6800	7,600	10,000	13,000
200,000	8100	8800	10,000	12,200	16,000

Pressure Tanks.

Note: For construction and installation rules, see National Board of Fire Underwriters' pamphlet on Tanks.

Pressure tanks are installed upon the principle that a moderate amount of water under heavy pressure is as efficient for sprinkler protection as a greater amount

* These were 1914 prices. Present prices (1918) are about 85% higher.

of water under lighter pressure. This is true for a small fire but not necessarily so for a fire of considerable size. Pressure tanks are necessarily limited to comparatively small sizes and should never be used except where there is another source of supply of large volume available. They are especially desirable in city risks where there is a waterworks supply of only light or moderate pressure available. Thus if the public water supply is ample in volume, but gives only 5 to 15 pounds on the top line of sprinklers, a pressure tank, giving as it does a heavy pressure on the first few heads that operate, is a desirable supply. The pressure is heavy at the start (which is the critical time in the extinguishment of the fire) but diminishes quite rapidly as the flow continues.

If the air pressure is maintained as called for by the rules, the minimum pressure, when the last water is leaving the tank, is 15 pounds.

Pressure tanks should always be located on the roof or upper floor. Otherwise the pressure which it is necessary to maintain will be excessive. If the tank is on the roof, the pressure required is 75 pounds. If it is below the roof an excess pressure is required equal to three times the pressure due to the height of the sprinklers above the tank. For example, if the pressure tank is 10 feet below the highest sprinklers, the excess pressure over 75 pounds would be three times the pressure due to the height of 10 feet. This height is equivalent to a water pressure of 4.3 pounds (one foot of water giving a pressure of 0.43 pound) and three times this is 13 (12.9). Therefore 88 pounds pressure should be carried. If the tank is located in the basement of a six-story building, the pressure required would be about 165 pounds, which is a very difficult air pressure to produce and maintain.

Pressure tanks should be enclosed in a heated room or roof house and should be used for sprinkler service only.

They should be filled two-thirds full of water and one-third of air. Sufficient pressure should be pumped in by means of an air compressor to comply with the above mentioned rule.

The common sizes of pressure tanks are as follows:

- 4500 (3000 gallons of water).
- 6000 (4000 gallons of water).
- 7500 (5000 gallons of water).
- 9000 (6000 gallons of water).

No general rule can be given for determining the proper size of tanks for buildings, but in practice they are seldom called for of a size that would give more than half the water that would be specified in case a gravity tank was used. Thus a 6000-gallon tank (4000 gallons of water) might be used where there were 80 sprinklers on a floor or where an 8000-gallon gravity tank would be called for.

Where capacities larger than 7500 gallons are needed it is usually better and more economical to use two smaller tanks instead of one large one. Thus in a building having 100 sprinklers on a floor, two 4500-gallon tanks (6000 gallons of water) might be used.

Steam Pumps.

Note: For rules for construction and installation see National Board of Fire Underwriters' pamphlet on Steam Pumps.

A modern Underwriter steam pump is an excellent supply for a sprinkler system as well as for hydrants provided it is well located and maintained and has ample water supply. There should also be an ample supply of steam available at all times so that the pump can be started without delay.

Nearly all styles of fire pumps are built in three principal sizes, namely, 500, 750 and 1000 gallons per minute. Some pumps are also built in 1250- and 1500-gallon sizes. They are all multiples of 250 which is the number of gallons per minute required for a standard hose stream.

The proper size of a pump for any given plant depends largely upon the other supply available. The combined capacity of both supplies should be enough to supply the number of hose streams thought to be desirable as well as the sprinklers that are liable to open. The 500-gallon size is too small for good protection except in plants of unusually small size, or when used to increase the pressure from low-service waterworks. As a standard hose stream required 250 gallons per minute, such a pump is good for only two standard streams. The 750-gallon pump is suitable for some of the smaller plants but the 1000-gallon size is the one most generally used and the small additional cost over one of smaller capacity is usually justified. If a larger pumping capacity is desired it is good practice to install two pumps so that if one is out of commission at any time there will be something to fall back upon.

Rotary Pumps.

Note: For rules for construction and maintenance see pamphlet of National Board of Fire Underwriters on Rotary Pumps.

Up to 1914 the rules recognized type A and type B rotary pumps but at present only the type B is approved. The type A was a modification of the older pumps which had been on the market for many years but which were rather inefficient types of pumps. Type B was designed especially for fire fighting and contained some radical changes in the old design.

Rotary pumps are not usually as good fire-fighting devices as steam pumps on account of the fact that they wear much more rapidly and cannot be as readily repaired when worn. They frequently have to be located in wet places where they are subject to corrosion and where they cannot be easily cared for. In a plant that depends upon water power and has no adequate steam supply, a rotary pump may be found necessary as it is the only approved pump, except the

centrifugal pump, that can be readily connected to water power.

Centrifugal Pumps.

Note: For rules for construction and installation see pamphlet of National Board of Fire Underwriters on Centrifugal Pumps.

These pumps are a comparatively new invention and are not yet in very general use. They are high-speed pumps and are particularly well adapted to locations where the source of power is electricity.

Electric Pumps.

Note: For rules for construction and installation see rules of National Board of Fire Underwriters for Electric Pumps.

Either rotary, centrifugal, or plunger pumps may be fitted for electric drive. They are expensive to install and in most cases expensive to operate. The requirements for power supply and transmission are severe and in many locations these cannot be readily complied with. Electric pumps are usually not economical to install except in power houses or street railway property where electric power can be obtained at a low cost.

Steamer Connections.

These are desirable for all equipments where there are steamers available that can pump into the system in case of fire, and especially where the other supplies are weak in pressure. Their use is, however, practically limited to the larger cities, as it is only here that steamers and efficient departments to man them are available at short notice. In cities where the public water pressure is light and



STEAMER CONNECTION.

where the fire department

is willing to coöperate in their use, they are of especial value.

The rules require the hose connection to be not less than 4 inches in diameter and as a matter of fact larger sizes are seldom used. Each connection should be fitted with a check valve but not with a gate valve. It is quite usual to install double or siamese connections, in which case each inlet should be checked against the other. This is most easily accomplished by locating one double-acting check in the Y of the connection.

There should be a $\frac{3}{4}$ -inch drip pipe so located that it will drain the piping between the check valve and the outside hose coupling.

Hose connections should be attached direct to the sprinkler riser on single riser equipments. On wet-pipe systems connection should be made above the gate and alarm valves so that if the valve should be closed the steamer connection would still be operative. In dry systems it is not practical to make the connection above the dry valve, as it is very difficult to make the check valve air-tight. It should therefore be connected below the dry valve but preferably above the gate valve. Where there is more than one riser controlled by valves, the connection should be made below the gate valves so that if any gate valve is closed the other risers may be supplied. In general hose connections should feed the system above all shut-off valves whenever possible.

Hose connections should be of brass with the same thread as that used by the fire department (National Standard if possible). Each outlet to be kept covered with a brass or iron cap to keep out dirt, stones, etc. Connection to be plainly marked, showing the purpose for which it is intended, by raised letters at least one inch in size.

Underground Pipes and Fittings. Only cast-iron pipe to be used for underground work and the weight to

be in accordance with the Standard Specifications of the American Water Works Association. Extra heavy piping to be used where pressures exceed 125 pounds per square inch.

TABLE FOR WEIGHTS OF ORDINARY CAST-IRON PIPING

Diameter in inches.	Weight per foot in pounds.	Diameter in inches.	Weight per foot in pounds.
4	23	12	91.7
6	35.8	14	116.7
8	52.1	16	143.8
10	70.8		

Where a system of yard piping can be laid out on a loop, better protection can be obtained with smaller pipe sizes than where the piping runs to a dead end. In no case should the pipe be less than 6 inches in diameter, and where the plant is large enough to require more than three 2-way hydrants and a sprinkler connection, an 8-inch pipe should be used.

For three 2-way hydrants or less, 6-inch pipe may be used if it is looped. Where system is not looped the next larger size of pipe is usually necessary. For supplying six hose streams or more the yard system should be at least the equivalent of an 8-inch loop or a 10-inch dead end system.

A 6-inch pipe should not be used for supplying more than three hose streams.

Where a number of sprinkler connections take off from an underground system in addition to the hydrants, the pipes should be sufficiently large to supply both. It is usually safe to allow for enough water to feed one quarter the sprinklers on one floor of one fire section in addition to the number of hose streams thought to be necessary. Each sprinkler head will require 20 to 40 gallons per minute, depending upon the pressure. A standard hose

stream discharges 250 gallons per minute. This amount is delivered by a hose stream with $1\frac{1}{8}$ -inch nozzle under about 60 pounds pressure.

Where long lines of pipe are used, care should be taken to make due allowance for friction loss. For new clean pipe the friction loss per 1000 feet is approximately as follows: for 6-inch pipe, 10 pounds with 500 gallons flowing and 40 pounds with 1000 gallons flowing. For 8-inch pipe, 2.3 pounds with 500 gallons flowing; 9 pounds with 1000 gallons; 21 pounds with 1500 gallons and 37 pounds with 2000 gallons. For 10-inch pipe, 7 pounds with 500 gallons flowing; 2.9 pounds with 1000; 6.6 with 1500; 12 with 1500 and 26 with 3000. For 12-inch pipe, 2.6 pounds with 1500 gallons flowing; 4.7 pounds with 2000 and 10 with 3000. Corrosion, sediment and sharp bends increase these figures considerably.

Great care should be taken in laying underground pipe to see that it is buried well below the frost line. The safe depth varies with the location from $2\frac{1}{2}$ feet in the south to 10 feet in northern Canada, measured from the top of the pipe to ground level. The best local practice should be followed, provided it has been found safe during the recent cold winters, bearing in mind that there will probably be no flowage in these pipes most of the time.

All piping should be tested for two hours under 150 pounds pressure, or if normal pressure is to exceed 100 pounds, to a pressure at least 50 pounds above normal. Pressure should be put on the pipes before the trench is filled in if possible.

Care should also be taken in properly supporting the pipe in poor soil, in anchoring the pipe on steep inclines and in carefully filling in and tamping around all underground pipe when it is laid.

CHAPTER VII

ALARM VALVES

An alarm valve is a very inexpensive and valuable addition to the fire protection in a sprinklered risk and is strongly advised for every equipment. It consists of a device which is installed in the main sprinkler riser and is arranged to actuate some form of alarm as soon as water flows through the system. These alarms are of two types: rotary gongs, operated like water wheels, by the passage of water through them; and electric gongs, operated by the movement of a check valve or by the closing of an electric circuit through the action of water pressure on a diaphragm. Alarm valves are valuable for two reasons: they give an alarm when sprinklers open on account of fire, thus acting as a fire alarm; and they give warning in case of flowage through the system for other causes such as a broken pipe, opening sprinkler head, etc. For the latter reason they are of great importance from a sprinkler leakage point of view, and most companies insuring against this form of loss require either an alarm valve in the system or standard watchman's service in the risk insured.

TYPES

There are two principal types of alarm valves that have been successfully used. In one a check valve is placed in the main water pipe and the movement of the clapper when water begins to flow, transmitted usually through a packed stem, is used to actuate the alarm. In the other type a check valve is also used and this, when in its normal position, closes an outlet to a small

pipe running to the alarm devices. This is accomplished by having the small pipe run from a groove in the valve seat, a horn in the water way or an auxiliary valve outside the main water way. In any type, a retarding or interrupting element should be used to retard the alarm long enough so that water hammer will not produce a false alarm.

The early valves were of the first type and usually had no retarding element. The most common variety was that using a swing check with an arm attached which extended through a stuffing box to a lever on the outside. This lever was so arranged that when it was moved forward by the opening of the check, a mechanical gong was tripped or an electrical circuit connected to a bell was completed.

This was a very crude form of alarm valve and particularly defective in the following points:

1. Sticking of the packed stem. The packing used to make a tight joint often caused the stem to stick owing to its age or to its being packed too tightly. In many cases this sticking was great enough to cause a serious menace to the equipment by obstructing the water way.

2. Susceptibility to false alarms. Any valve of this character, having no retarding element, is very liable to give false alarms from water hammer. A slight impulse in the water would force the clapper off its seat and would probably give an alarm if the device was adjusted to operate for small flows.

3. Lack of sensitiveness. Where the movement of a large check valve is used to give an alarm it is evident that the amount of water necessary to feed one sprinkler head would only open the valve a very small amount. It is therefore very difficult to adjust the device so that it will operate for small flows caused by the opening of one or even two heads.

4. The valves were liable to stick open. This was

especially the case where the lever was weighted so that when it started to move the weight would carry the clapper over to the wide open position.

In addition to the above the electrical and mechanical gongs used at this time were crude and unreliable. The mechanical gongs had to be rewound each time they operated and this was frequently forgotten. Valves of this type have not been installed to any extent for many years and but few are now found in the field.

HISTORICAL SKETCH

In 1881 *Mr. J. C. Meloon* of Providence patented an alarm valve of the vertical check type in which the movement of the clapper operated an auxiliary valve which admitted water from below the check valve to a chamber. The water pressure in the chamber actuated a diaphragm which, when it moved, tripped the catch of a mechanical alarm.

In 1884 *Mr. Charles E. Buell* patented a valve of the packed stem type in which the lever attached to a swing check started a train of clockwork actuated by a weight. This rang a mechanical gong. The Walworth Manufacturing Co. also made some valves of this general type.

Another of the early valves of this type was the *Neu*. This was a vertical check valve seating like a globe valve on a horizontal seat. A spindle extended through a stuffing box at the top and closed an electrical contact when the clapper was raised by the flowage of water. This had practically all the defects of the swing check type except the liability to stick open.

The *Grinnell Angle Alarm*, so-called, was somewhat similar to the *Neu*. It was a vertical check of the angle type. A rod attached to the lower side of the check valve contained a groove, and a horizontal pin passing through a stuffing box to the outside of the casing rested

in this groove. When the valve opened the pin was pushed a short distance forward thus making an electrical connection or tripping a mechanical gong.

This valve was an improvement over the old swing check as it was less subject to false alarms. The valve could lift slightly without giving an alarm and there was less chance of sticking. Like the older valve, however, it had no retarding element and was difficult to adjust so as to be sensitive to small flows and at the same time not to be subject to false alarms.

In 1888 *Messrs. R. Dowson and J. Taylor* of Bolton, England, patented in this country the well-known English Alarm Valve. This was manufactured by the General Fire Extinguisher Co. for many years and is still used in a slightly modified form. It is also the basis of several other valves and embodies perhaps the most successful principle that has ever been used in alarm valve construction. It consisted of a vertical check valve having a grooved seat. A pipe extended from the groove to a rotary gong actuated by the flow of water. When the valve was seated, the groove was tightly covered by the clapper and no water could escape. When the valve was raised by flowage in the system, the water entered the groove and flowed to the water rotary gong.

In the original valve there was no retarding chamber and the valve was therefore somewhat subject to false alarms from water hammer. There was, however, a small compensating valve located in the main check valve which allowed water in small quantities to pass upwards through the alarm valve but not back again. This was installed to prevent trouble from water hammer by building up an excess pressure in the system above the main check valve.

The same year (1888) *Mr. Frederick Grinnell* patented a very ingenious device which, however, was never put on the market so far as known. The principle involved

was apparently a very effective one for preventing false alarms from water hammer although in case it failed to work properly it completely blocked the water way.

It consisted of a double or balanced valve comprising two self-packing pistons $h - h$ located several inches apart and connected by a rod running in a guide. The pipe from the water supply b' was connected between

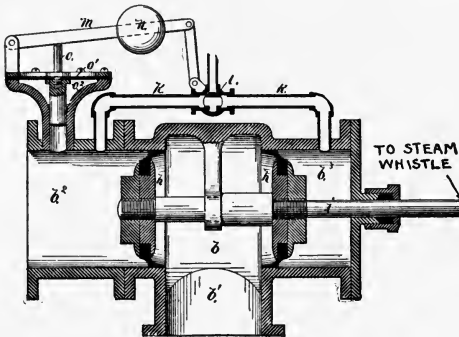

GRINNELL ALARM DEVICE 1888.
(Section.)

the two pistons, when in their normal position, so that there was an equal pressure on each, thus balancing the valve.

The cylinder in which these two pistons could move horizontally was connected at one end to the sprinkler riser and at the other end to a pocket b^3 normally full of water. A rod i connected with the pistons extended through the pocket and a stuffing box to the outside of the casting. Here it came in contact with a valve supplying a steam whistle. A small by-pass k extended around the two pistons of the alarm valve connecting the sprinkler riser with the pocket. In this by-pass was a three-way cock l which when in its normal position left a free way through the by-pass, thus equalizing the water pressure in the riser and in the pocket.

This three-way cock was connected to a lever arm *m* actuated by a flexible diaphragm *o* and connected by a short piece of pipe to the riser. When in normal position the two pistons spanned the inlet pipe and prevented any flow of water into the riser. Any water hammer or variation in pressure acted equally on both pistons and gave no alarm. When, however, a sprinkler operated the pressure in the riser was reduced. This caused the diaphragm to drop, thus moving the lever downward and changing the position of the three-way cock so as to close the by-pass but open a passage from the pocket to a waste pipe. This relieved the pressure in the pocket thus causing the two pistons to move in that direction to the limit of their travel. This opened the main water way from the supply pipe into the riser and at the same time operated the steam whistle.

The *International* valve was of a somewhat similar principle to the English Alarm valve. Instead of a grooved seat, however, a horn was used. This horn extended from outside the casing to the under side of the main clapper of a swinging check valve. When the clapper was on its seat, it also closed the open end of the horn. When the clapper was raised, the water flowed into the horn, hence through the retarding chamber to the circuit closer and rotary gong. The retarding chamber was, however, of an entirely different principle from that used in the English Alarm valve as will be described later.

The first *Rockwood* alarm valve was practically a copy of the English valve. The present type has a grooved seat and, in addition, a by-pass containing an auxiliary valve to care for the small flows.

The *Venturi* valve made by the Venturi Alarm Co., and installed by the Manufacturers' Automatic Sprinkler Co. (later by the "Automatic" Sprinkler Co. of America), is of a radically different principle from any other alarm valve.

There is a weighted swing check in the main water way but no grooved seat or horn. There is a by-pass around the check valve containing a Venturi tube, that is a tube containing a restricted portion or throat. Water flowing through such a tube has an increased velocity accompanied by a decrease in pressure at the throat. This difference in pressure is made use of to give an alarm by piping one side of a mercury column to the throat, and the other side to the full-sized pipe below the throat. A heavy iron float rests on one side of the mercury column and when water passes through the by-pass, owing to flowage in the system, the float falls and its movement opens an outlet which allows the water to flow to the alarm devices.

In February, 1908, *Mr. E. L. Thompson* of the Manufacturers' Automatic Sprinkler Co. patented an alarm valve which operated entirely on account of reduction of pressure in the system when a sprinkler opened. It was a complicated device containing a balanced valve which fell when the pressure was reduced thus allowing water to pass into a pipe which operated an electrical and water rotary gong. This was never used in practice so far as known.

Mr. Geo. E. Hibbard of Chicago patented a valve in 1903, which could be used either as an alarm or dry valve. This depended upon an excess pressure being maintained above the valve and was never used so far as known.

INSTALLATION

In all types of alarm valves great care should be taken in the matter of installation. Most of the valves on the market have had a remarkably good record so far as giving an alarm in case of fire is concerned, but the record of false alarms has not been satisfactory. The greater portion of this trouble has, however, been due

to defective installation. A few of the more important points that are often overlooked are the following:

1. Vent for circuit closer. There should be a small outlet about $\frac{1}{8}$ inch in diameter located under each circuit closer so that when the water flow ceases the pressure under the diaphragm will be released at once and the circuit will be thereby broken. This also allows the pipe from the diaphragm to drain quickly by admitting air at the upper end. The vent should be piped through a visible outlet and so arranged that water discharged from it will do no damage.

2. All drips should run to the space under the building or out of doors in such a manner that the chance of clogging or freezing will be reduced to a minimum. Drips running to a sewer are liable to cause trouble by the backing up of water which may operate the alarms. When it is necessary to connect to a sewer, the drip pipe should run into an open cup or into a pipe of larger diameter, this latter pipe running to the sewer. The top of the cup can be closed with a sliding cover if desired and this, not being air-tight, will prevent any back pressure from reaching the retarding chamber. The piping should be arranged so that the end of the drip can be easily inspected for leaks. If necessary a trap can be placed in the large pipe that connects with the sewer. The drip from the circuit closer can easily be carried to the same drain pipe.

3. The water rotary gong should be located as near the alarm valve as possible. If located at too great a distance from, or at too great an elevation above, the alarm valve, the loss of head entailed may cause trouble. In case the length of pipe is over 15 feet it is desirable to enlarge it to at least 1 inch diameter. This pipe should be arranged so that it will drain quickly.

There should be a substantial hood and screen over the gong to prevent clogging by ice, birds' nests, etc. These are usually supplied with the valve.

RULES FOR DESIGNING AN ALARM VALVE

The following specifications give a general idea of the requisites for a satisfactory alarm valve.

1. Must be capable of actuating and maintaining in operation either mechanical or electrical devices, or both.

2. The electrical alarm type must be capable of actuating an electrical circuit opener or closer, according to the character of the alarm circuit to which it may be connected.

3. The combination electrical and mechanical type must operate to set and maintain in operation both alarms, or either independently.

4. Must operate at all rates of water delivery from the system, exceeding ten (10) gallons per minute.

5. The retarding factor must not exceed thirty (30) seconds. The retarding factor is here defined as the time elapsing between the first movement of water past the valve due to opening of a system outlet and the completion of the act by which the valve actuates the alarm devices; it is not construed as including the delay incident to excessive lengths of connecting pipes leading to such devices, or other delays which may be largely dependent in magnitude upon details of installation or excess pressure above the valve.

6. Must be equally operative, without special adjustment, at all service pressures for which it is rated.

7. Must discontinue alarms on stoppage of flow.

8. Must be capable of transmitting successive alarms without manual resetting.

9. Must not spatter water upon the surroundings of the valve nor cause waste of water.

10. Must not give false alarm under any variation in service pressure for which it is rated.

11. Must be substantially constructed and not embody delicate parts.

12. Must not waste water while in service and not in operation.

13. Must not depend on moving parts which are liable to become stiffened by corrosion, other results of lapse of time or by misadjustment.

14. Must be so designed as not to invite improper adjustment in the field.

15. Must not require frequent renewal, or adjustment of parts.

16. Must have all working parts readily accessible for removal and repairs.

17. Must be made up and shipped from the factory in such form as not to be liable to incorrect installation or assembly.

18. Must not be susceptible to accumulation of foreign matter.
19. Must not be liable to failure from the effects of corrosion, sticking of parts or ordinary accumulation of sediment and other foreign matter from the piping.
20. Must not possess sufficient differential properties to cause danger of water columning in service or undesirable action in operation.
21. Must not depend, for proper action, on manually-wound spring motors or any other form of motive power which is liable to be out of commission when needed.
22. Electrical contact devices must be so protected from moisture that they will be dry under all conditions short of actual submerging of the apparatus.
23. Must not invite internal or external gagging. The necessary test valves and devices must be as simple as possible. If of such nature or so located that they may be carelessly left in condition to render the alarm devices inoperative, provision must be made for pad-locking or sealing them, in proper operative condition only.
24. Must not cause excessive loss of pressure by hydraulic friction.

NATIONAL BOARD RULES FOR ALARM VALVES

See Sprinkler Rules Section G.

The National Board rules for alarm valves state that every sprinkler system should contain an alarm valve that will operate an electrical, a mechanical gong or both. The character of the property and the local conditions should determine just what bells should be used and where they should be located. In a city risk the electric bell should if possible be located in a fire department house or in a central station. It is also very desirable to wire it on a closed circuit in such locations. It is often advisable to omit the rotary gong when the risk is located in a congested district on account of the panic or the frightening of horses which might result from the ringing of so large a gong.

In small towns or villages both electric and rotary gongs are desirable and the electric bell should be at a fire department house or in the dwelling of some inter-

ested party. In some cases, the electric bell can be located in the power house of some nearby plant where there is some one on hand nights, Sundays and holidays.

The alarm valve should be so located that the supplies from all automatic sources will pass through it. This excludes steamer connections and occasionally pump supplies although it is usually better practice to have the pump water pass through the alarm valve. This necessitates bringing all water supplies together below the valve, as, for instance, bringing the tank supply down to the basement level and connecting it with the town water supply under the main gate valve and alarm valve. It was formerly customary to feed the tank supply into the top of the riser but this is not allowed today, except in the case of risks having no other supplies than gravity or pressure tanks. In this case, which is sometimes found in cities having a waterworks system of very light pressure, the alarm valve and controlling gate valve may be located at the top of the building thus doing away with the extra friction loss due to the water flowing down to the low level and then returning through the riser.

The wiring for electric bells should be in conformity with the rules given in the National Board of Fire Underwriters' pamphlet on *Signalling Systems*.

TESTING

All alarm valves should be tested occasionally to make sure they are in good working order. Once a week should be often enough under any conditions and once a month is frequently sufficient.

The principal sources of trouble to be looked for are: the failure of the electric bell due to exhausted batteries, corrosion at bell or broken wire; the failure of the rotary gong due to clogging at the outlet or binding of parts; sticking at the seat of the valve. This latter

is infrequent, but occasionally occurs with valves having a soft rubber seat especially if there is a heavy water pressure on top of the clapper. The electric bell is by far the most usual part of the device to get out of order, largely due to battery trouble, and it is well to test this as often as once a week. This can be done by short-circuiting the wires without disturbing the alarm check or the water rotary. A push button should be installed for this purpose connected directly to the binding posts at the circuit closer and not tapped into the wires running to the bell. In this way the entire circuit is tested and if the main wires are corroded or broken off at the binding posts this fact would be brought out on test. If the push button is tapped into the wires running to the bell, any break at the binding posts or between them and the point where the button is tapped in would not be discovered by the test.

A testing device giving a record of the test on a paper dial is very desirable. A small tester, made on the same principle as the test clock for thermostat systems, was formerly made for this purpose but so far as is known there is nothing on the market today suitable for this purpose.

It might be possible to use a small magneto actuated by the rotary gong instead of batteries for supplying current to ring bells, thus doing away with one of the most frequent causes of trouble.

When a closed outside circuit is used, the wires are always in test and it is not, therefore, necessary to make frequent tests of the electrical features.

The best way to make a complete test is to open the small (usually half-inch) test pipe at the top of the sprinkler system. If this is properly installed it should give a flow, when wide open, approximately equal to the discharge from one sprinkler head, and this is the minimum flow at which an alarm valve can be expected to operate.

Defects. The principal defect in alarm valves today is the liability to false alarms. A modern valve properly installed should give but little trouble but if not installed strictly according to rules, trouble may be expected. This trouble is often overcome by maintaining an excess pressure in the system above the alarm valve. There is no great objection to doing this except that it causes extra work and if carried to an extreme may tend to cause the valve to stick. It also makes the valve slower in operation as the excess pressure must drop to normal before the main check will open. In plants where this is done the Assured usually do not test the system as often as it should be tested and also object to tests being made by insurance inspectors.

In alarm valves containing soft rubber facings the rubber ring should be replaced every few years and perhaps oftener where the pressure is very heavy.

FIRE RECORD

While the record of alarm valves is not very satisfactory so far as false alarms is concerned, and while they are frequently found out of order on inspection, their fire record has certainly been good. The statistics of the National Fire Protection Association for 22 years covering various forms of alarm service are as follows:

	Fires	Failures	Per cent of failures
Thermostats alone.....	230	48	21
Watchmen alone	1738	179	10
Sprinkler alarm alone.....	1849	115	6

APPROXIMATE COST

Alarm valves cost from \$250 to \$300 each according to size at present prices.

in a vertical or horizontal position. There was an auxiliary check valve connected by an arm to the main clapper and closing the port to the alarm devices. This auxiliary valve had a loose, self centering valve disc actuated by a light spring but normally held on its seat by the water pressure in the system. It was so located that it was not likely to be affected by scale or sediment.

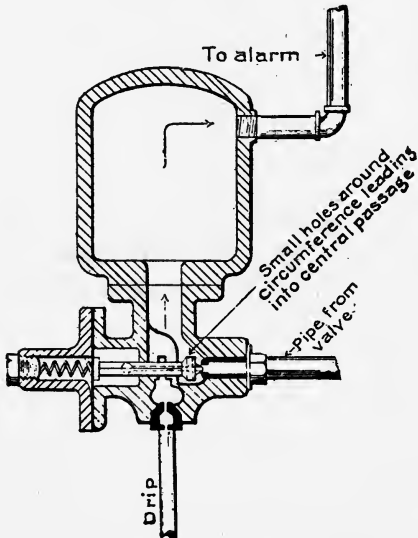

ASSOCIATED ALARM VALVE RETARDING CHAMBER.
(Section.)

The Retarding Chamber contained an inlet at the lower side normally closed by a valve and an outlet to the alarm devices, taking out at the upper side. The inlet valve was attached to a diaphragm behind which was a coiled spring. The valve disc was drilled with sixteen small holes to permit a small amount of water from the alarm valve to pass through the inlet valve and act on the diaphragm. When sufficient pressure accumulated, the diaphragm was pushed back and

the valve thereby opened. There was a small drip which drained the retarding chamber and this was normally open. When the inlet valve opened, it seated against this drip, thus closing the drip outlet. The water then filled the chamber and passed through the outlet pipe to the alarm devices. When the water flow ceased the auxiliary valve closed, thus stopping the flow to the retarding chamber. The diaphragm was then pushed forward by the spring, thus closing the inlet valve. This action opened the drip and drained the chamber and pipe to the alarm devices.

The electric circuit closer consisted of the usual knife switch operated by a diaphragm.

The rotary gong consists of a wheel with single buckets operated by two nozzles.

The device gave an alarm with from 7 to 10 gallons per minute flowing. The retarding element was about 20 seconds.

The device was installed to considerable extent from 1914 to 1916 when the company combined with the Globe Automatic Sprinkler Co.

Rating: *Not standard. Generally satisfactory.*

CARPENTER

Patented by *Orville Carpenter of Pawtucket, R. I.*

1897. (Probably used before that time.) This was a magnetic valve with no provision for a water rotary attachment. A hollow iron ball *B* was used which when in its normal position rested on lugs *C'* in the water way, which it practically filled. Above this point the water way was enlarged so that when the ball was carried up by the movement of water it did not seriously obstruct the flow. There were also lugs *D'* higher up, to limit the height to which the ball could rise.

Outside the main valve casting and separated from it by a tight brass partition *C2* was a brass casing contain-

ing a suspended magnet *F*, one end of the magnet coming close to the brass partition so that the iron ball was in the field of the magnet.

When flowage occurred in the riser, the iron ball, which nearly floated, was carried up, thus taking it outside the magnetic field. The suspended magnet then

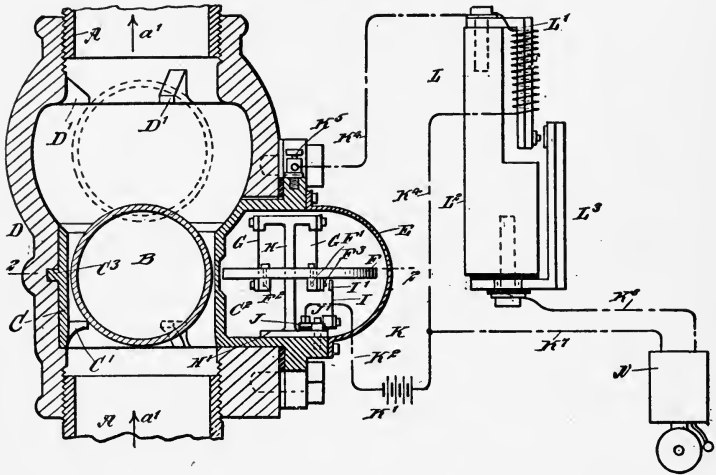

CARPENTER ALARM VALVE.
(Section.)

swung back away from the partition, and in so doing closed an electrical circuit at *I*. This was arranged to ring an electrical bell at any desired location, through a retarding element.

This valve was used in a few equipments but did not prove satisfactory. There was a possibility of the ball becoming filled with water and thus being too heavy to operate properly.

Practically obsolete.

Rating: *Unreliable*.

CROWDER

Made by *Crowder Bros., St. Louis, Mo.*

1909. Vertical check seating on a horizontal valve seat. It is guided by a stem at the top and three projecting brackets underneath. There is an auxiliary

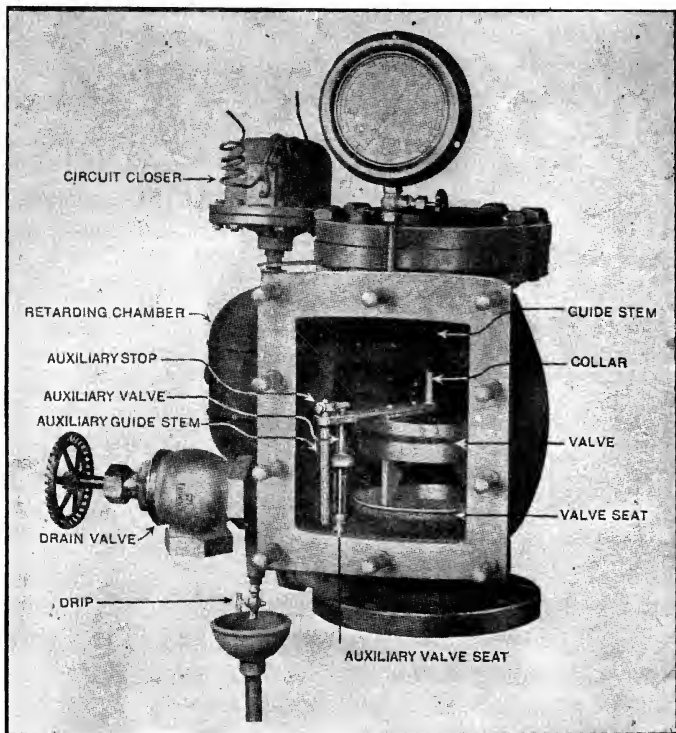

CROWDER ALARM VALVE.

valve attached to the main valve and closing over an opening running to a retarding chamber. When the main valve is on its seat, the auxiliary valve closes the outlet to the retarding chamber. There is a small petcock in the pipe to the chamber and this is normally open.

When the main check rises, the auxiliary valve is opened and water flows into the retarding chamber. The retarding action is due to the difference in capacity of the pipe to the retarding chamber and the open drip through the petcock. There are no valves in this chamber. Said to operate under normal conditions in 5 to 8 seconds.

Rotary gong when used is connected to the pipe running to retarding chamber at petcock.

Has been used to a limited extent since 1909. Field experience said to be satisfactory.

Rating: *Not standard.*

EVANS

Merchant & Evans Co., Philadelphia, Pa.

D-1914. This valve contained a weighted swing clapper, seating at an angle. The passage to the retarding chamber was controlled by an adjustable auxiliary valve supported on an arm extending from the main clapper. This valve consisted of a bronze plunger without diaphragm or spring but held to its seat by the water pressure.

The valve remained seated after the main clapper had slightly opened, thus giving a retarding action. A $\frac{1}{2}$ -inch pipe led from the auxiliary valve to the upper part of the retarding chamber where it was screened. There was a double diaphragm in the lower part of the chamber, the upper part of which contained a $\frac{3}{8}$ -inch hole. Attached to the diaphragm was a valve which normally closed the port leading from the inlet screen. There was a small hole in this valve which allowed water to drain down to the diaphragms, hence through the small hole in the upper diaphragm to the drip pipe which was connected between the diaphragms. Below the diaphragms was a pressure chamber connected by a small pipe to the main riser below the alarm check.

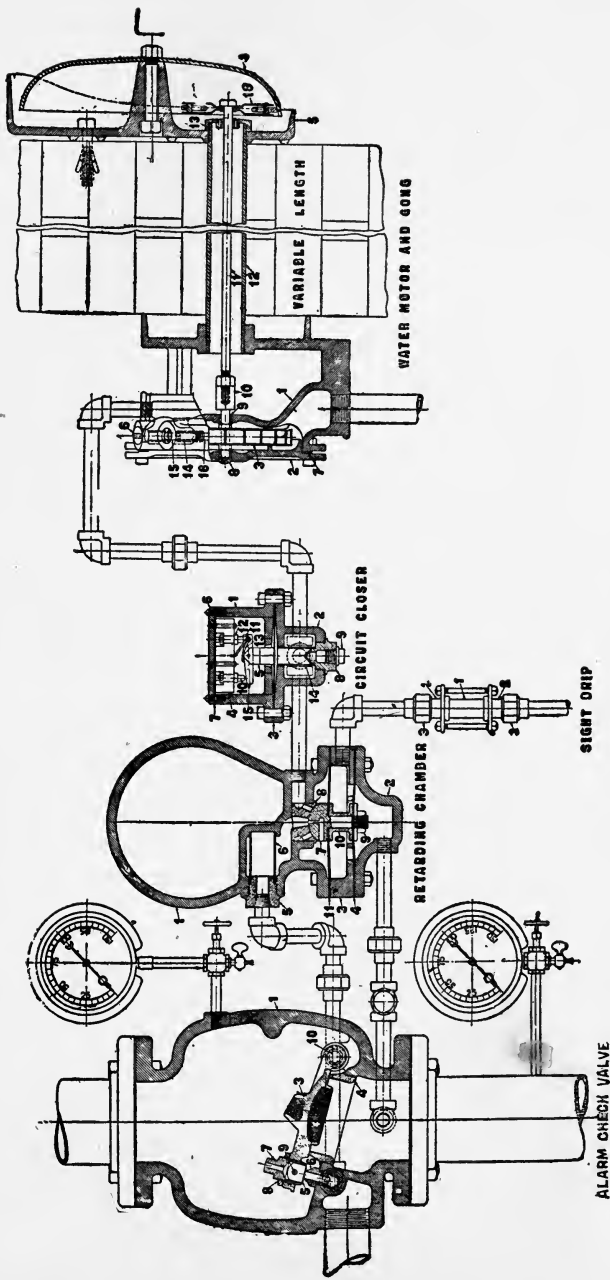

EVANS ALARM VALVE
(Section)

Normally the pressure from the water in the riser acting through the small pipe on the under side of the lower diaphragm held the diaphragm up, thus closing the small valve in the port, which was attached to it. In case of water flow in the system the auxiliary valve opened, thus allowing water to flow into the upper part of the retarding chamber. A small amount of water passing through the small hole in the diaphragm valve and the hole in the upper diaphragm acted on the lower diaphragm, finally forcing it down and opening the valve in the port. This gave full opening to the alarm devices which were connected by a pipe leaving the retarding chamber at a point between the upper diaphragm and the attached valve. When the water flow ceased the retarding chamber and piping were drained through the small holes mentioned above.

The electric circuit closer and rotary gong were of the usual type, there being two nozzles pointing downward to actuate the water motor.

This device gave an alarm with about 9 gallons per minute flowing in the system. The retarding element was about 15 seconds.

Field experience is generally satisfactory.

Rating: *Not standard. Generally satisfactory.*

GRAY

Frank Gray, Chicago.

1897. Double vertical check valve on a single spindle running in a guide. From the intermediate space between the two valves a pipe ran to a small chamber containing a cylindrical float. This chamber was drained by a small open pipe. There was a small by-pass around the two valves to take care of water hammer.

When the flowage was sufficient to raise the valves, water filled the intermediate space and flowing into the

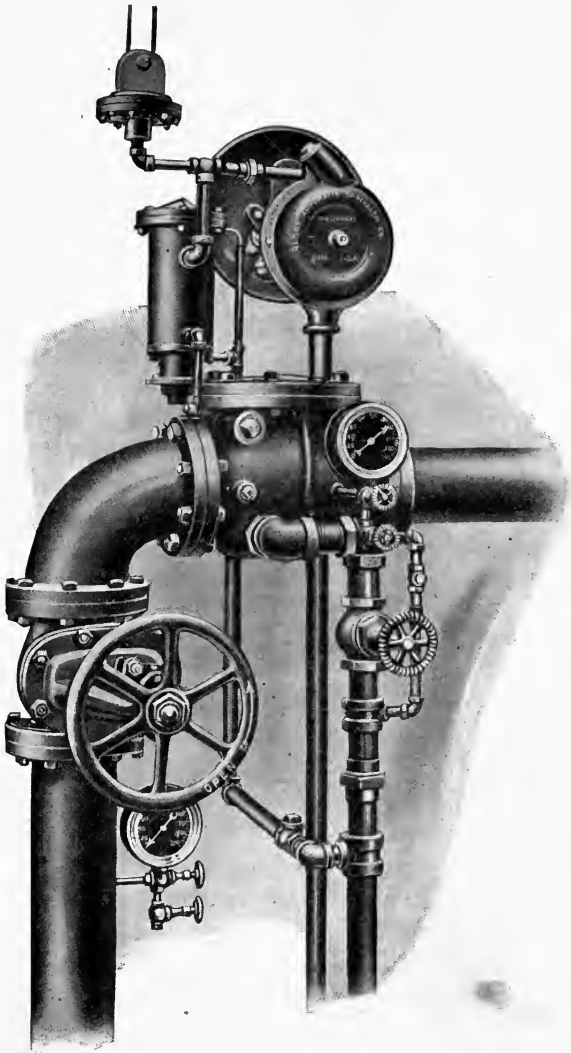

GARRETT ALARM VALVE.

chamber raised the float which closed an electrical circuit by forcing two contact points together.

No rotary gong was shown in the patent drawing although this could readily be installed.

Not generally used so far as known.

Now practically obsolete.

GARRETT

Globe Automatic Sprinkler Co., Cincinnati, O.

This is a swing check seating on a grooved horizontal seat. There is a rubber facing on the clapper to make a tight joint.

The pipe from the grooved seat runs to the lower part of a

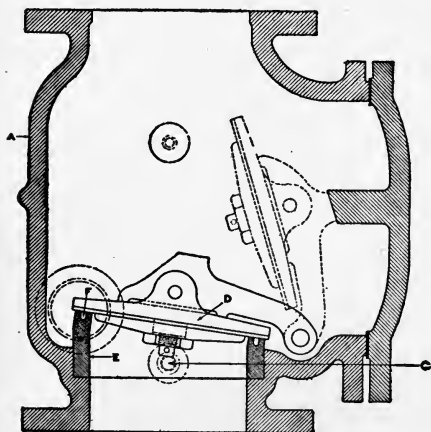

GARRETT ALARM VALVE.
(Section.)

- A, main casting.
- C, outlet from grooved seat.
- D, main clapper.
- E, valve seat.
- F, groove.

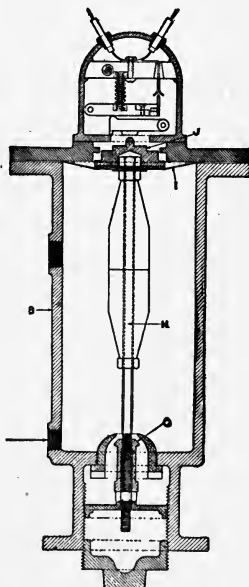

GARRETT RETARDING
CHAMBER.
(Section.)

- I, diaphragm.
- M, weighted rod.
- D, drip valve.

retarding chamber. There is a metal diaphragm at the upper end of the chamber which, when it is thrown up, operates a knife switch connected to the electrical circuit. A weighted rod is attached to the diaphragm and at the lower end of this rod is a valve leading to a drip pipe. A $\frac{3}{4}$ -inch pipe to the rotary gong connects to the chamber near its upper end.

Water entering the chamber from the grooved seat leaks out through the drip valve until enough pressure has accumulated to throw up the diaphragm. This closes the drip valve and at the same time operates the knife switch on the electrical circuit.

Field experience limited but said to be satisfactory.

Rating: *Not standard. Generally satisfactory.*

GLOBE A, B, C.

Globe Automatic Sprinkler Co., Philadelphia, Pa.

Models A, B, and C were experimental types varying only slightly from later types, particularly with refer-

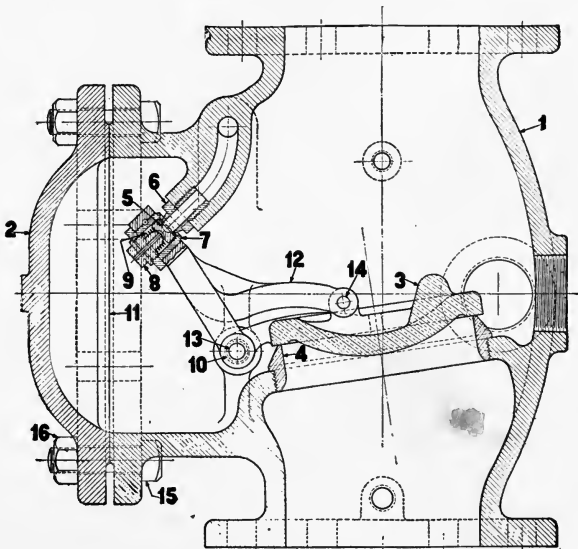

GLOBE ALARM VALVE (Model E).

ence to supplementary opening and clearance around hinge pins.

Model D, 1916. Same as Evans D.

Model E, 1917. Similar to Model D except opening to retarding chamber is located higher up above main current of water where it is less liable to clogging and is easily accessible when bonnet is removed. There are two outlets for standard drip pipes and other minor changes including slight change in circuit closer.

Rating: *Not standard. Generally satisfactory.*

GRINNELL ANGLE ALARM VALVE

Made by the *Providence Steam & Gas Pipe Co.*

1885. This consisted of a vertical check valve lo-

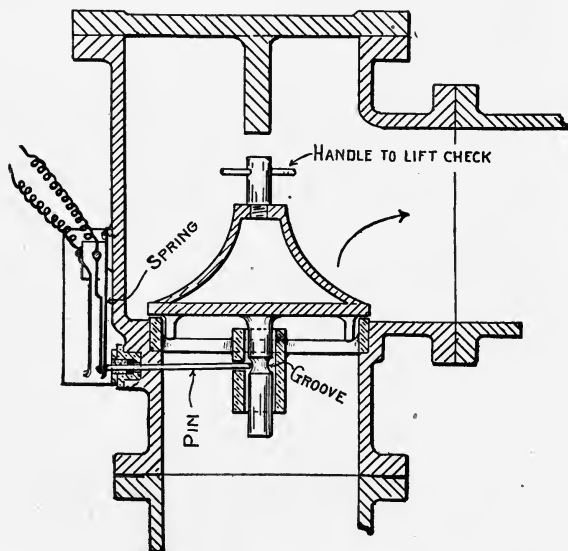

GRINNELL ANGLE ALARM VALVE.
(Section.)

cated in a casting which was in the form of an angle. There was a round stem containing a groove attached

to the lower side of the check. A pin was inserted in the side of the valve in such a way that one end of the pin rested in the groove of the stem when the valve was closed. When the check was raised by the passage of water, this pin was pushed outwards a short distance by the pressure of the stem below the groove. This motion was utilized to make an electrical connection or to trip a mechanical gong.

A good deal of trouble developed in the course of years from the sticking of the pin, for there had to be a stuffing box to make a water-tight joint. Another undesirable feature was the possibility of the pin becoming bent and thus being prevented from moving easily along its guides. These defects were so serious that this type of valve was finally condemned and most of them have either been taken out or have had the pin removed.

A considerable number were installed. Field experience fairly satisfactory for a few years.

Present rating: *Unreliable. A menace to sprinkler system.*

GRINNELL ENGLISH ALARM VALVE

Patented by *Dowson & Taylor*. Manufactured by *Providence Steam & Gas Pipe Co.* Later by the *General Fire Extinguisher Co.*

1-1888. A vertical check valve with a rubber facing seated on a grooved seat. A small auxiliary valve in main check allowed water to pass upwards through the valve but not to return. This tended to create an excess pressure above the valve and thus to prevent false alarms.

Pipe from grooved seat ran direct to rotary gong and circuit closer with no interrupting pot.

But few installed. Now practically obsolete.

Rating: *Subject to false alarms. Unsatisfactory.*

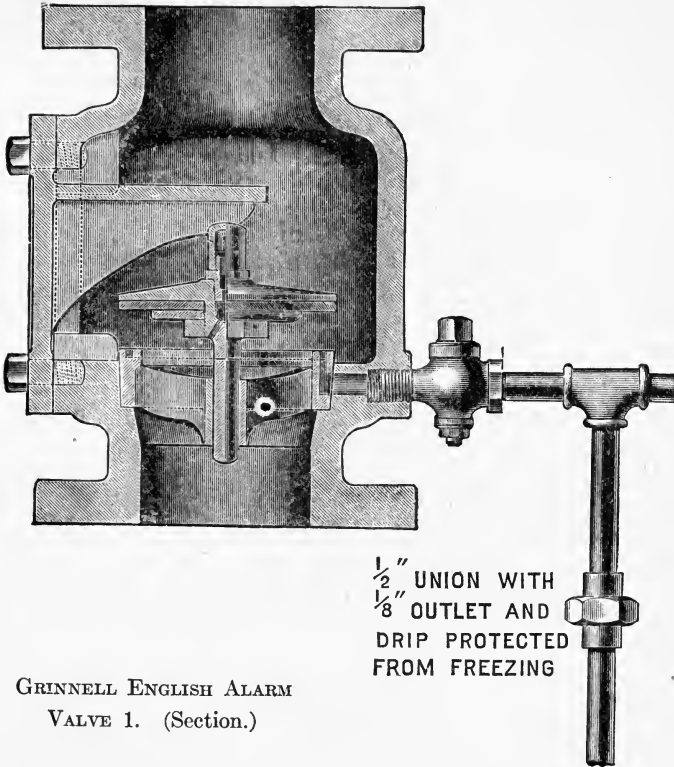

GRINNELL ENGLISH ALARM
 VALVE 1. (Section.)

2-1890. Similar to No. 1 but with interrupting pot. This pot had a small outlet at the bottom protected by a long vertical strainer. The outlet being smaller than the inlet the pot gradually filled with water when the main check valve was raised and water entered the grooved seat.

Some of the early types gave trouble from sticking of the rubber valve at the grooved seat. This was especially the case where the valve was in a warm place or where there was normally a heavy pressure on top of the valve. Later a hard rubber was used for this purpose.

There was a metal diaphragm at the top of the chamber. When the chamber became full of water this diaphragm was raised and an electrical connection was made.

The time element of the retarding chamber was about 20 seconds.

The water rotary connected directly with the pipe from the grooved seat. The water rotary gong, consisting of a wheel with paddles like a water wheel, was revolved by a stream of water issuing from a nozzle. When the wheel revolved, a hinged hammer on the outside of the building was made to strike a large gong.

A large number were installed. Field experience quite satisfactory though the device was somewhat subject to false alarms. New circuit closers, properly vented, have been in-

stalled on some of these old valves to obviate this trouble.

Rating: *Not standard. Fairly satisfactory.*

3-1900. Main valve similar to previous type but without auxiliary check valve. Interrupting chamber and circuit closer redesigned. The outlet pipe from the chamber ended in an elbow pointing up. A valve arranged to close the end of this outlet was attached to a metal

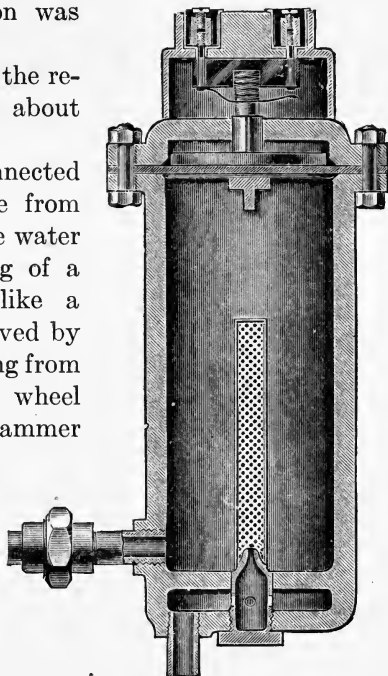

GRINNELL ENGLISH ALARM VALVE 2.
RETARDING CHAMBER.
(Section.)

diaphragm in the bottom of the chamber. The pipe to the circuit closer and rotary gong connected at the top of the chamber.

When the water entered the chamber from the grooved seat it created a pressure on this diaphragm. When the chamber became full, the pressure was sufficient to operate the diaphragm. This pulled down the valve onto the outlet pipe and closed the outlet. The water then flowed to the rotary gong and circuit closer from the top of the chamber.

The circuit closer contained a diaphragm which operated a knife switch.

Many of these valves were installed and are still in use. Where properly installed the field experience has been quite satisfactory.

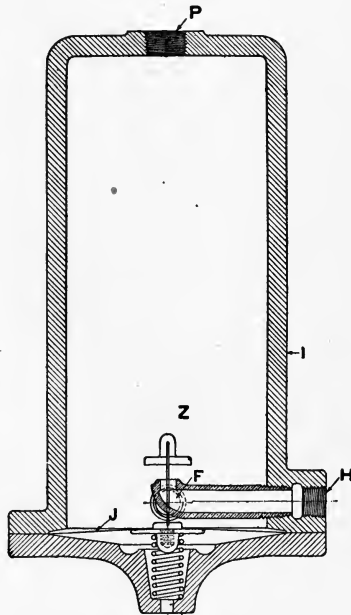

GRINNELL ENGLISH ALARM VALVE 3.
RETARDING CHAMBER.

(Section.)

Rating: *Not standard. Generally satisfactory.*

GRINNELL STRAIGHTWAY ALARM VALVE

General Fire Extinguisher Co., Providence, R. I.

1908. Swing check with grooved seat. Capable of being used in upright or horizontal position. A pipe from grooved seat runs to an interrupting chamber of the same design as that used in the No. 3 English Alarm

valve. Circuit closer and rotary gong are also of the same design as those in the English Alarm No. 3.

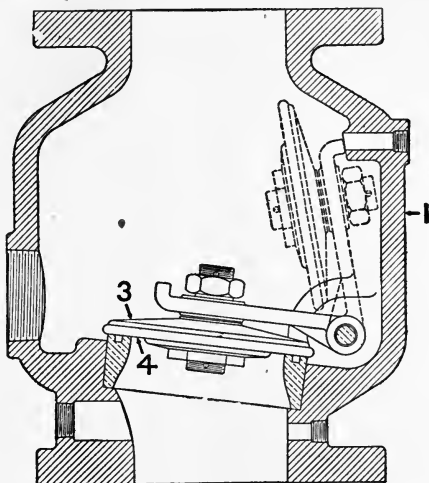

GRINNELL STRAIGHTWAY ALARM VALVE.
(Section.)

Criticized by the Underwriters' Laboratories in 1907 as follows:

- Somewhat subject to false alarms.
- Susceptible to improper installation.
- Water motor alarm inefficient.

Many of these valves are in use. Where properly installed field experience has been quite satisfactory.

Rating: *Not standard. Generally satisfactory.*

HARKNESS TEE

Made by the *Harkness Fire Extinguisher Co.* Redesigned by the *General Fire Extinguisher Co.*

This was a constant-pressure alarm designed for branch pipes. It consisted of a thin copper flapper supported by a flexible diaphragm. When in its normal position, the flapper closed the water way. In case of flowage

it was pushed to one side and this motion transmitted through the flexible tube made an electrical contact outside the pipe.

It was not designed to use with a water rotary gong and could only be used where the water pressure was very constant, as where a tank was the primary supply.

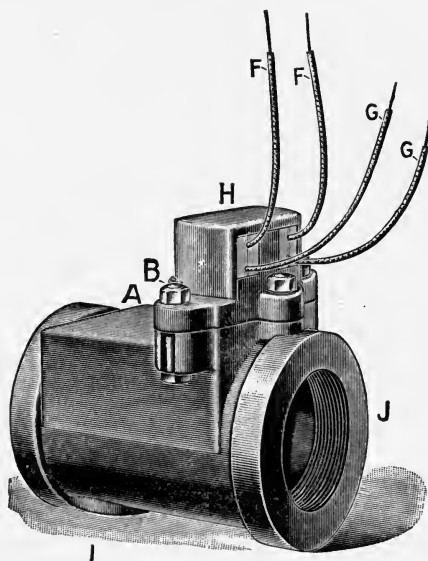

HARKNESS TEE.

J, main casting. H, circuit closer. F, G, wires to circuit closer.

By installing one on the branch pipe feeding each floor and connecting the wiring to an annunciator, the device would show the floor on which a fire occurred.

Used to a considerable extent in city risks. As redesigned it is being used in connection with supervisory apparatus.

Field experience quite satisfactory.

Rating: *Not standard. Satisfactory under constant pressures only.*

HUNT

Jarvis Hunt, Chicago. Assigned to *Phœnix Fire Extinguisher Co.*

1904. Vertical check valve, hollow and shaped like a truncated cone. It was guided by rods passing through supports above and below the check. Seated on a grooved seat, a pipe from which ran to the atmosphere.

No retarding element or alarm connections shown in the patent drawing. Valve designed to be used either as a differential dry valve or an alarm valve. The buoyancy of the valve was supposed to prevent water columning.

Not used to any extent so far as known.

INTERNATIONAL

Made by *International Sprinkler Co., Philadelphia.*

1901. This company first used an alarm valve of the swing clapper type with a stem extending through a stuffing box. This was soon discarded for the better known "horn" type. This valve was put on the market in 1901 and consisted of a swing check valve seating at a slight angle, designed to be used in either a vertical or horizontal position. A horn, connected to a small pipe, extended through the casing into the water way just below the check valve. When on its seat, the check valve also rested on the end of the horn, thus tightly closing the outlet into the small pipe. There was a diaphragm inserted in the lower side of the main check, at the point where the check valve covered the horn. There were perforations in the edge of this diaphragm so as to admit water above it, thus making it easier to adjust the valve so as to give a tight joint both at the main seat and at the horn.

When the check valve was raised off its seat, due to flowage in the system, water entered the horn and flowed to the interrupting pot and finally actuated the alarms.

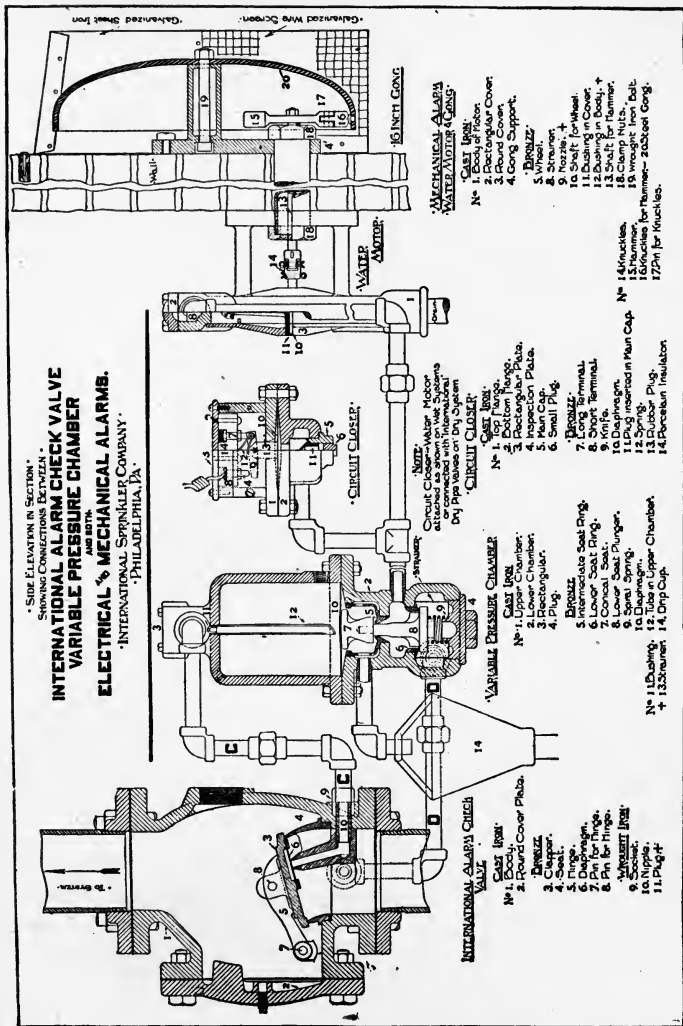

INTERNATIONAL ALARM VALVE. TYPE C.

The interrupting chamber or time element was of an entirely different principle from that in any other valve. It consisted of three compartments, an upper, a middle and a lower one. A valve between the lower and middle compartments was held closed by water pressure coming through a pipe that connected with the riser below the main check and ran to the lower compartment. The small pipe from the horn ran to the upper compartment. There was a thin metal diaphragm at the bottom of the upper compartment separating it from the middle one. The pipe to the alarm devices connected with the middle compartment.

When the alarm valve was closed, no water could enter the horn and there was therefore no pressure in the upper compartment. The water pressure from below the main valve held closed the valve between the middle and lower compartments. There was, therefore, no pressure in the middle compartment.

When the main check valve opened, water entered the horn and flowed from this into the upper compartment. When this became full, the pressure forced down the diaphragm in the bottom of this compartment, thus opening the valve between the middle and lower compartments. The water from the lower pipe then flowed into the middle compartment and thence to the circuit closer, the water rotary gong or both.

This valve was criticized by the Underwriters' Laboratories in 1905 as follows:

1. Variable in action under high and low pressure especially with small water flows.
2. Subject to leakage (through valve).
3. Some parts fragile and susceptible to improper adjustment.

In 1912 they criticized in addition:

1. Liability to false alarms.
2. Reliability doubtful under service pressures of less than 25 pounds.
3. May obstruct flow of water in riser.

A large number of these valves have been installed and the field experience has been generally satisfactory.

There are four types of this valve varying but little from each other. Early types sometimes known as Evans' Alarm Valve.

A-1901. Horn of large diameter ($1\frac{1}{2}$ -inch in 6-inch size) with flaring outlet seating on diaphragm in about the center of the clapper. Circuit closer on top of retarding chamber.

B-1902. Horn of smaller diameter ($\frac{3}{16}$ -inch) and not flaring as much, seating in center of clapper.

C-1903. Similar to *B* but horn somewhat off center of clapper.

D-1906. Diaphragm discarded and horn seats on an adjustable plug adjusted from upper side of clapper.

Circuit closer connected to pipe running to rotary gong in all but *A*.

Rating of all types: *Generally satisfactory.*

MANUFACTURERS

Manufacturers Automatic Sprinkler Co. of New York.

Swing check with packed stem. Subject to false alarms under fluctuating pressures.

Present rating: *Unreliable and menace to sprinkler system.*

VENTURI OR MANUFACTURERS

Submitted to the Underwriters' Laboratories by McNab & Harin Manufacturing Co.

The Venturi alarm valve is made by the Ohio Automatic Sprinkler Co., and installed by the "Automatic" Sprinkler Co. of America.

A-1907. There is a weighted check valve around which there is a small by-pass containing a Venturi tube. This tube, starting with a given diameter at the lower side of the main check, decreases rapidly in diameter until the throat is reached and then increases more

TYPE D. DESCRIPTION.

- 2, clapper.
- 3, horn.
- 4, adjustable plug closing end of horn.
- 10, pipe from horn to upper compartment of retarding pot.
- 12, strainer.
- 59, pipe from supply pipe to lower compartment.
- 21, pipe from middle compartment to circuit closer and rotary gong.
- 56, drain pipe for sprinkler system.
- 53, drain pipe from retarding pot.
- 16, diaphragm containing a small hole 17.
- 31, diaphragm in circuit closer.
- 25, switch in circuit closer.
- 36-50, rotary gong.

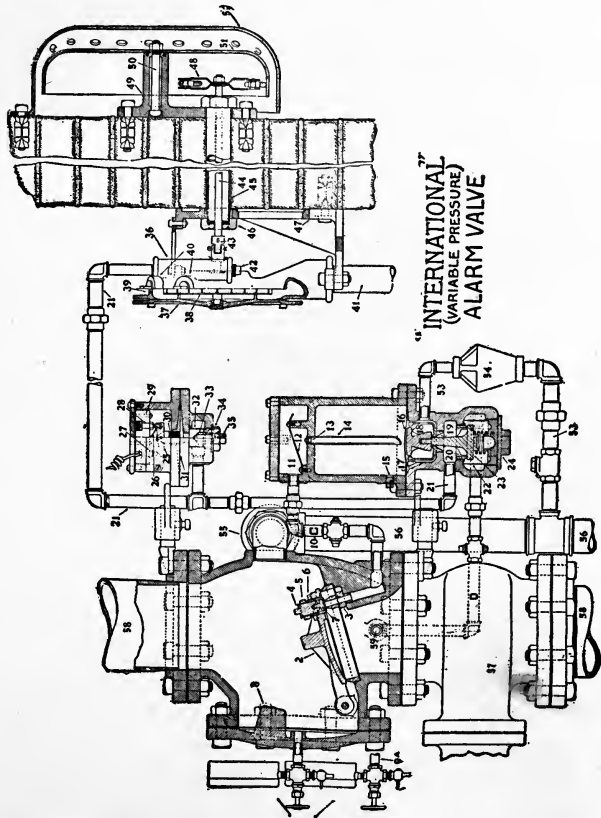

VENTURI ALARM VALVE A.
(Section.)

- 1, main clapper.
- B, iron float on mercury column.
- 8, pipe from riser to one side of mercury column.
- 3, pipe from Venturi throat to other side of mercury column.
- 10, (Fig. 2) valve opened by dropping of float, thus letting water into pipe 15.
- 17, circuit closer.
- 19-28, rotary gong.

Fig. 3. Venturi tube, A, throat of tube.

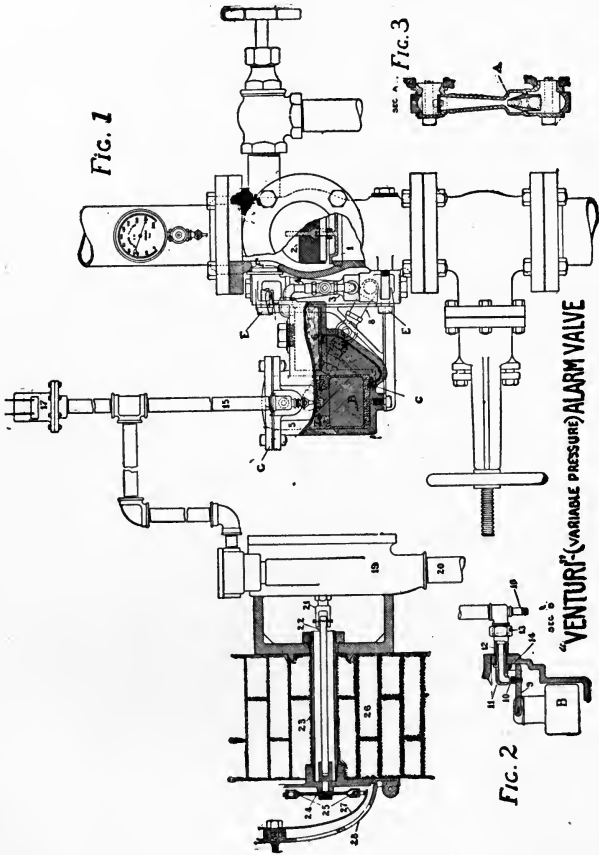

VENTURI-(VARIABLE PRESSURE) ALARM VALVE

gradually to the original diameter. Water passing through such a tube increases in velocity and decreases proportionally in pressure at the throat. This feature is used in an ingenious way to actuate an alarm-giving device. A double column, or, more correctly, a double chamber of mercury, is arranged with a heavy iron float on one side of the column. When in its normal position, this float holds closed a valve on the end of a pipe leading to the circuit closer and rotary gong. There is one pipe running from the riser below the main check valve to the float side of the mercury column and another pipe running from the throat of the Venturi tube to the other side of the column. When the system is in normal condition, the mercury is at the same level in each side of the column and the valve on the pipe to the gongs is closed. When water begins to flow in the riser, it causes a flow through the Venturi tube. The pressure at the throat of the tube is decreased and this decrease is transmitted to one side of the mercury column. The float therefore falls and opens the small valve to the gongs.

This type of valve has been used quite successfully for several years. One feature that is apt to cause trouble and which must be carefully watched is the wedging open of the main check valve which might cause a failure of the alarm to operate and still would give no trouble alarm. In case a small stick, stone or other obstruction should lodge on the seat of the check and hold it open no alarm or trouble signal would probably be given. In case a sprinkler opened, the water to feed it would flow through the main check instead of through the Venturi by-pass. In other types of valves the wedging open of the check valve in this way will cause a continuous alarm until the trouble is remedied and no failure in case of fire would result.

To reduce the possibility of such trouble to a mini-

mum a quarter-inch test pipe is installed just above the main check. This can be used to make a final test after there has been a flowage of water through the system. If the alarms will operate with this quarter-inch test pipe open, it is safe to assume that the main check is on its seat or at least there is not enough obstruction under it to cause trouble.

Another feature which is liable to cause trouble is the possible leakage of mercury at the gage joints, although this has now been well guarded against.

The time element in this valve depends upon the size of the orifice through which the mercury has to pass in flowing from one chamber to the other. This orifice is wedge shaped so that the mercury flows back a little faster than it flows in.

Reported upon by the Underwriters' Laboratories in 1909. Features criticized:

1. Unreliability of alarm at rates of flow around 300 gallons per minute.
2. Danger of clogging of mercury column.
3. Danger of mercury leakage.
4. Susceptibility to misadjustment.
5. Effects of water eddies at inlet.
6. Inaccessibility of main valve seat.
7. Liability of failure to send in alarm if check is not tightly seated.

In June, 1912, the following criticism was also made.

Liability to false alarms.

A large number have been installed and field experience has been generally satisfactory where properly installed and adjusted.

Rating: *Not standard. Generally satisfactory.*

B-1910. Similar to *A* but with main check valve seating at an angle and Venturi tube in a vertical position. There is less liability of this device being improperly set up.

Rating: *Not standard. Generally satisfactory.*

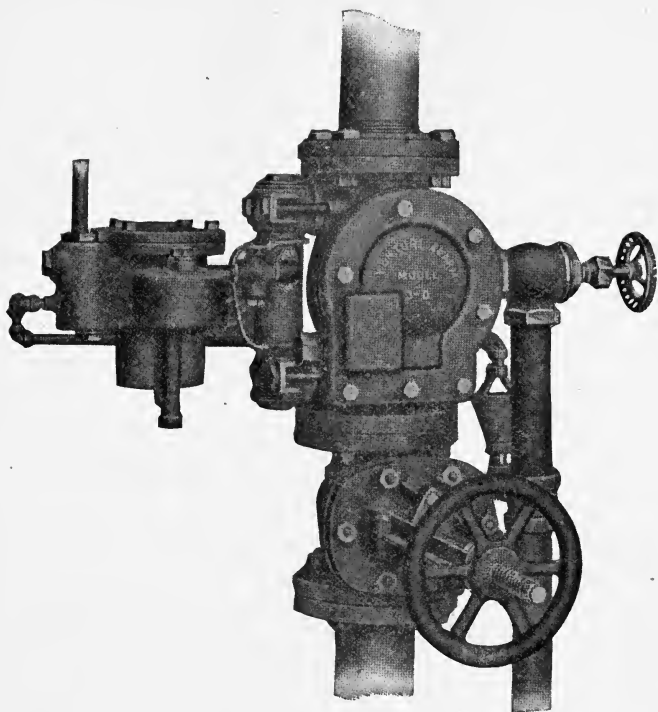

VENTURI ALARM VALVE 3D.

3D-1914. Similar to type A except as follows:

1. Main clapper is less heavily weighted and has a boss projecting about $\frac{1}{4}$ inch below the seat ring. This retards the wide opening of the clapper at the first part of its movement.

2. Connected to the spindle of the main clappers and moving with it, except for a slight looseness, is a $\frac{3}{4}$ -inch auxiliary clapper covering the outlet to a double-seated tube. The inner tube leads to a waste pipe and the outer tube or channel leads through a small pipe into the Venturi tube at a point about half way

along its down-stream nozzle. This auxiliary device insured that water will always be drawn through the tube, giving an alarm whenever the main clapper is off its seat and thereby eliminating the principal defect in the former device. As the small check operates with the main check, the channelled seat ring is exposed when the main check opens and water will flow through the Venturi tube to the open air by way of the channelled seat and bleed pipe.

3. The Venturi tube has been slightly modified in form to give more correct velocities. It is placed vertically and is covered at the outlet or upper end by a gravity check valve. Screens have been placed at both ends of the Venturi tube.

4. The mercury pot is now a solid casting with no glass gage or other joints below the mercury level. This to prevent possible leakage of mercury.

The small passage from the high to the low pressure side of the mercury pot contains a small hard rubber differential check device operating vertically by means of its buoyancy in the mercury. This permits prompt restoration of the mercury level in the two chambers after the flow has stopped, thus tending to eliminate false alarms.

The iron float has vertical corrugations on the side to reduce the friction. The pipe to the gong opens downward with a horizontal valve seat so no deposit is likely to obstruct this valve.

5. The motor pipe chamber has been screened and there are hand plugs to clean out the space below the screen. A brass plug with small orifice has been tapped into this chamber to drain the pipe to gong after the alarm has been given.

Approved by the Underwriters' Laboratories in July, 1915. Field experience fairly satisfactory.

Rating: *Standard.*

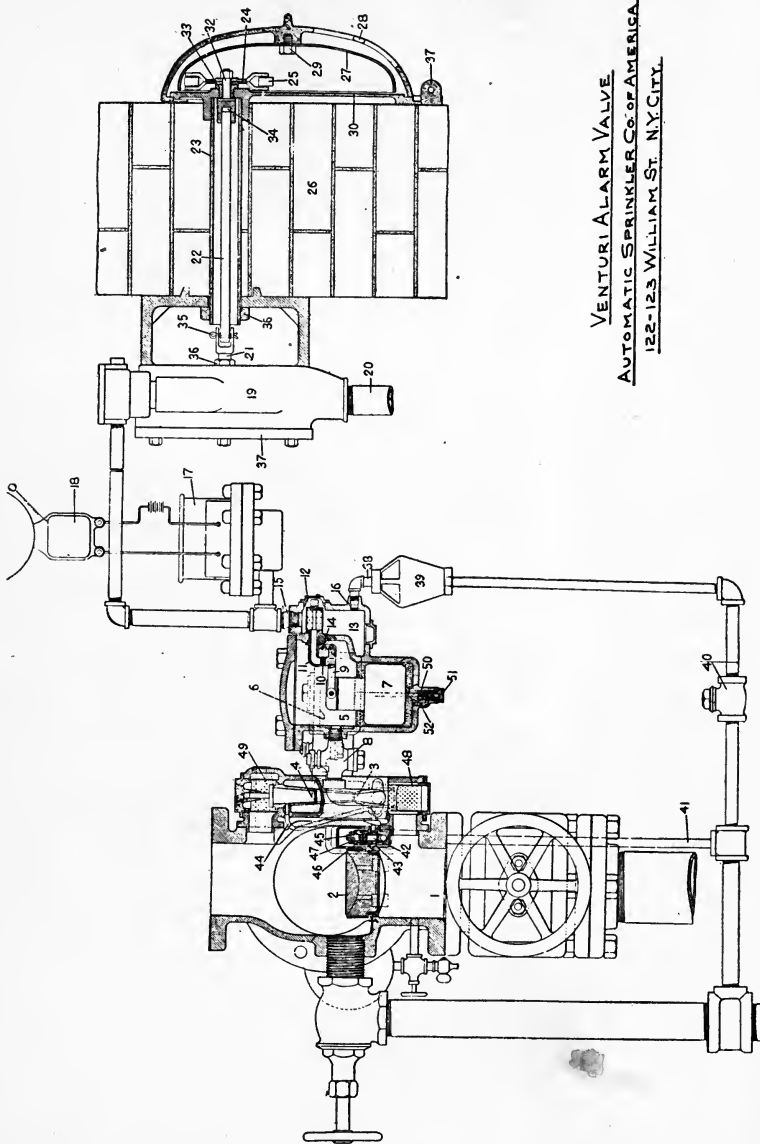

VENTURI ALARM VALVE 3 D.
(Section.)

VENTURI ALARM VALVE
 AUTOMATIC SPRINKLER CO. OF AMERICA
 122-123 WILLIAM ST. N.Y. CITY.

NEU

Gustave S. Neu, New York City.

Installed by the Walworth Manufacturing Co. and other sprinkler concerns.

This consisted of a vertical check valve seating on a horizontal valve seat in much the same way as the disc of a Globe shut-off valve.

There was a spindle on the lower side running in an interior guide supported by two arms. On the upper side was another spindle carrying a small plunger which ran through a stuffing box to a metal casing attached to the top of the valve. In this casing were two contact points which were brought together when the plunger was thrown up by the opening of the check valve, thus closing an electric circuit and ringing a bell.

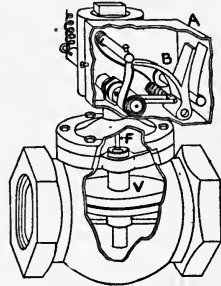

NEU ALARM VALVE.

(Part in section.)

V, valve clapper.

F, spindle.

A, contact case.

B, contact points.

This device had no provision for a water rotary alarm. It was subject to sticking at the stuffing box.

It was used to a considerable extent about 1895.

Reported upon by Underwriters' Laboratories in 1905. All features criticized.

Rating: *Unreliable. A menace to sprinkler system.*

NIAGARA

Niagara Fire Extinguisher Co., Akron, Ohio.

This was a swing-check valve with a weighted clapper seating on a phosphor bronze seat ring. The arm carrying the clapper was keyed to a rod which passed through the casing and actuated the alarm device on the outside. The rod or stem was rotated as the clapper opened or closed. Instead of a stuffing box at the point where the

stem passed through the casing, as was customary in old valves of this type, a flexible ground joint was used. This consisted of a ring attached to a metal diaphragm bearing on a ground plate. The water pressure in the system acting on the diaphragm caused a pressure on this ground joint which kept it tight. Not used to any extent so far as known.

Present rating: *Unreliable.*

ROCKWOOD

Worcester Fire Extinguisher Co. Later Rockwood Sprinkler Co.

1-1906. This was built on the same lines as the Grinnell English pattern No. 3. The main valve was a vertical check with rubber seat. The retarding cham-

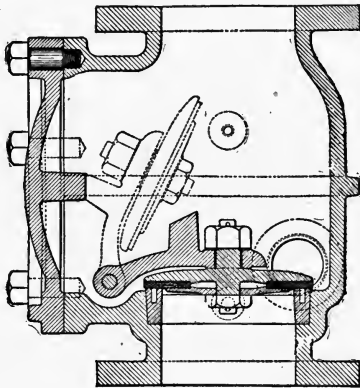

ROCKWOOD ALARM VALVE A.
(Section.)

ber had a valve at the end of the outlet pipe closed by the movement of a metal diaphragm.

But very few valves of this type were installed, and the retarding chambers have now all been replaced.

Rating: *Obsolete.*

A-1909. Similar to No. 1, except a swing check was

used. Retarding chamber redesigned. The pipe from the grooved seat entered the base of the retarding chamber through a screen. Taking a sharp curve it flowed through a Venturi tube into the chamber proper. A small drip ran from the throat of the Venturi tube to a drip pipe. This acted as a drain for the entire retarding chamber.

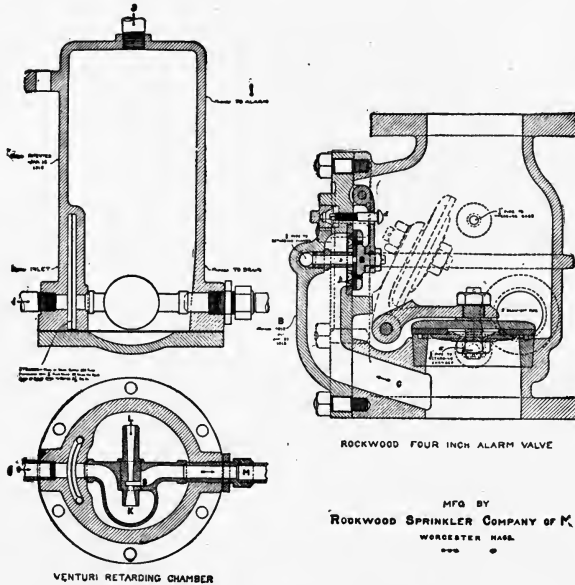

ROCKWOOD ALARM VALVE TYPE B.

Section of valve on right. Sections of retarding chamber on left. C, by-pass around main check. B, auxiliary valve in by-pass.

In case of water hammer the water from the grooved seat would not fill the chamber and would quickly drain out. In any case there would be a constant flowage from the drip pipe while the main check was off its seat.

This valve was installed to a considerable extent and gave fairly good results. Somewhat subject to failure of rotary under light pressures.

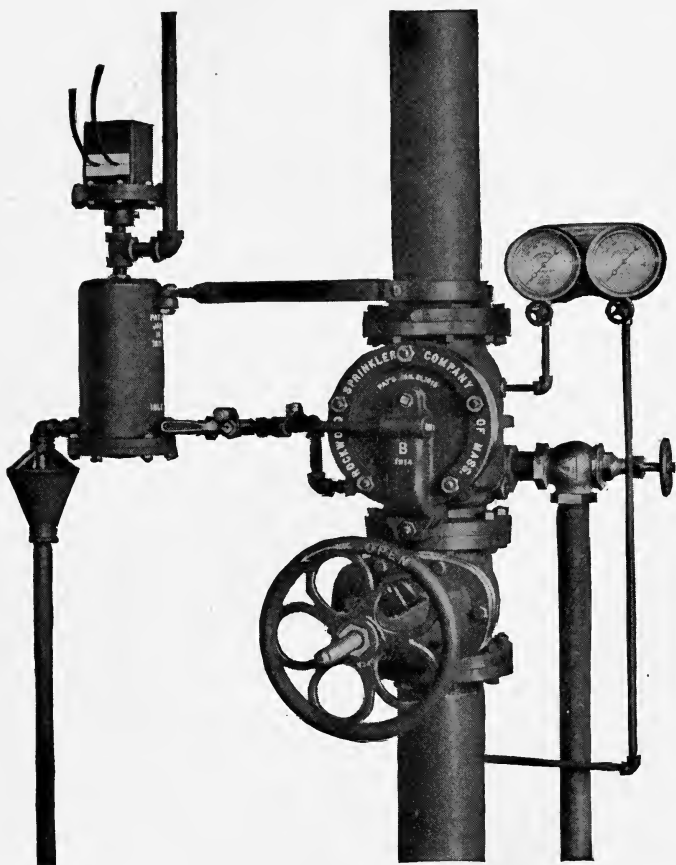

ROCKWOOD ALARM VALVE.
Exterior view showing retarding chamber, etc.

Rating: *Not standard. Generally satisfactory.*

B-1911. Main valve redesigned. Same retarding chamber as in A.

Main valve consists of a swing check seating on a horizontal grooved seat. Designed for a vertical position only. There is a small by-pass ($1\frac{1}{2}$ -inch on 4-inch size) around the main check with a swing check at the upper end. This check closes on the open end of the by-pass. A $\frac{1}{2}$ -inch pipe runs from the small by-pass to the retarding chamber connecting with the pipe from the main check just outside the chamber. This by-pass is designed to take care of small flows and water hammer so that the main valve will not open frequently.

This valve is being extensively installed and is giving fairly good satisfaction.

Rating: *Not standard. Generally satisfactory.*

WALWORTH

Walworth Manufacturing Co., Boston.

This was a swing check with lever attached to check passing through stuffing box to outside of the casing.

The movement of the lever, when the check opened, tripped a mechanical gong. No water rotary could be used with this valve.

Used to considerable extent. Now practically obsolete.

Field experience unsatisfactory. Subject to false alarms and sticking at the packed stem.

Rating: *Unreliable and a menace to system.*

Note: In late equipments the Walworth Co. used the Grinnell English type valve to some extent.

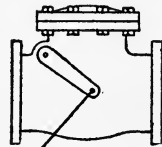

WALWORTH
ALARM VALVE.

CHAPTER VIII

DRY SYSTEMS AND DRY VALVES

DRY SYSTEMS. GENERAL FEATURES

A dry-pipe system is one in which there is air under pressure, instead of water, in the sprinkler pipes.

These systems are needed in buildings which are not sufficiently heated to prevent freezing in winter. They are never considered quite as effective as wet-pipe systems as they are slower in action, more complicated and more likely to cause interruptions in the sprinkler service.

A dry-pipe system is installed in a similar manner to a wet-pipe system except that more care is necessary in arranging all parts to drain properly and, on account of the increased difficulty of holding air under pressure, extra precaution should be taken to make all joints as tight as possible. A dry valve is installed in the system, usually inside the building at the lowest level, and when the system is in normal condition there is no water in the pipes above this point.

DRY VALVES

A dry-pipe valve is a device for holding back the water in a sprinkler system until fire occurs and then opening automatically and allowing the water to flow into the pipes. Air is pumped into the pipes above the dry valve and the pressure thus created holds the valve closed. These valves are always designed so a moderate amount of air pressure will hold back a much heavier water pressure. This is done for two reasons: first, because a heavy air pressure is difficult to pump up and

hard to maintain; second, because the time necessary to exhaust a heavy air pressure and the fanning effect on the fire of the escaping air both act against the quick control of a fire.

Several different types of dry valves have been invented but those in use today are of two types, the differential and the mechanical. In the differential type there is a double-seated check valve, the upper or air seat being much larger than the lower or water seat. The difference in area between these two seats determines the differential or difference in pressure necessary to balance the valve. Valves of this type are generally designed with a differential of about 7 to 1, that is one pound of air pressure on the upper side will just hold the valve closed against 7 pounds water pressure on the lower side. Examples: Grinnell and Rockwood.

In the mechanical type the check on the water side is held closed by a system of levers, these being held in place by the action of air pressure in the pipes. Here there is generally no fixed ratio of air and water pressure that will hold the valve closed but the valve is designed to open at a predetermined air pressure which, however, can be somewhat varied by the amount of pressure exerted on the adjusting screw. Examples: International, Manufacturers and Niagara.

All types of dry valves are subject to "water columning" if not properly installed and maintained. In other words if there is enough water in the pipes above the valve to produce a pressure on the valve greater than the pressure at which it will trip, then the valve is "columned" and will not open automatically. If, for instance, in a differential valve, having a differential of 6 to 1 and a water pressure of 30 pounds in the supply pipe, enough water should accumulate above the valve to make a column 12 feet high, the pressure of this water, namely a little over 5 pounds (0.43 pound to each foot),

would be more than one-sixth of the water pressure and would therefore hold the valve closed. This water pressure, unlike air pressure, is not reduced when a sprinkler head at a higher level opens. This feature gives little trouble in practice however.

Water accumulates above a valve in two ways: first, by slowly draining from the small end pipes which will not drain quickly when the main draw-off pipe is open owing to the vacuum action; second, by the condensation of water from the air which is pumped into the pipes.

Water collecting in the pipe above a dry valve may also cause trouble by freezing where the pipe is exposed. It is therefore of vital importance that the draw-off pipe above the dry valve be opened occasionally to drain off any water that may have collected.

It is essential that the intermediate space between the air and water valves in a differential dry valve be kept free from water. Should water leaking past the water valve fill this space under a pressure greater than the air pressure, the air valve would be opened and the system flooded. In all systems having a closed intermediate space this feature is safeguarded by an automatic drip. This drip takes care of any small leakage but closes automatically under the pressure resulting from the opening of the valve.

Operation. The general operation of dry systems is as follows. The system is set up by closing the main gate valve and draining off all the water above the dry valve. The dry valve is then set up and air pressure is pumped into the pipes. When the pressure has reached a sufficient amount to hold the dry valve closed, the gate valve is opened and the water pressure rests on the lower side of the dry valve. When a sprinkler opens, the air pressure in the pipes escapes until the tripping point is reached, when the dry valve is forced open by the water pressure thus allowing the water to flow into the pipes.

Maintenance. A dry system is much more difficult to maintain than a wet system because the air in the pipes is certain to leak out slowly, thus necessitating more or less frequent pumping. Unless the system is carefully watched and cared for the valve is liable to trip and flood the pipes. This would do no damage in warm weather, but in freezing weather great damage would probably result from frozen pipes.

The air pressure maintained should vary only between small limits, for too high a pressure will retard the action of the system and too low a pressure may allow the valve to trip. In a differential valve, with a ratio of 7 to 1 and with a water pressure of 80 pounds, the tripping point is about 12 pounds and the air pressure should range from 20 to 30 pounds. With a lower water pressure these figures could be somewhat reduced and with higher pressure they should be increased. In a valve of the mechanical type the air pressure should be between 30 and 40 pounds regardless of the water pressure.

NATIONAL BOARD RULES FOR DRY SYSTEMS

The rules of the National Board of Fire Underwriters for dry-pipe valves and fittings (Sec. H) state that dry-pipe systems should be used only where wet-pipe systems are impractical, and while not as desirable as wet-pipe systems they are far preferable to shutting off the water supply in cold weather.

Air pressure should be maintained on the system the entire year, except by special consent. This is required because the draining and filling of the system every year tends to cause corrosion in the pipes and frequently brings in dirt and sediment. Then again the Assured usually take better care of a system that is maintained dry the entire year. When water is admitted in the spring there is a strong temptation to neglect the system

during the summer and not to drain it and pump up the air until cold weather has already caused damage. Another undesirable feature is that when the water is in the dry system, all automatic alarm attachments must be shut off to prevent them from ringing continuously. Therefore, unless an alarm valve is also installed in the pipe, the alarm service must be sacrificed.

On the other hand it cannot be denied that a system with water in the pipes is somewhat quicker and more reliable in action (except for the alarm feature), for at best it takes an appreciable time for the water to reach a sprinkler after it has opened and dry valves are not infallible in their action. It is therefore occasionally wise to waive this rule. This is especially the case in new systems that are not perfectly tight, for by letting water remain in the pipes during the first summer, small leaks are frequently closed by corrosion and the system made much tighter. It is also questionable whether it is not wise to run the dry systems wet during the summer in the southern states where freezing weather lasts only about two months out of the twelve. The Factory Mutual Insurance Companies do not have this restriction in their rules. In fact they prefer to have water let into the system each spring and usually require a full-sized by-pass around the dry valve for this purpose. The gate valve in this by-pass is kept open during warm weather.

Drainage. Sprinklers on a dry system should always be installed in an upright position so that they will drain properly. Great care should be taken to arrange all piping to drain thoroughly and if possible to drain to one drip pipe located just above the dry valve.

The horizontal pipes should have a greater pitch than those in a wet-pipe system, namely, not less than $\frac{1}{2}$ inch in 10 feet, so that the pipes will drain more rapidly and thoroughly.

Supplies. All water supplies must be brought together below the dry valve so that they will feed the sprinklers through the valve.

Size of Systems. The number of sprinklers on one dry system is limited to 400 sprinkler heads, preferably not over 300. The larger the system the longer it will take for water to reach a head after it has operated, because of the larger amount of air to be exhausted. In a system installed in a grain elevator some years ago there were about 1500 heads on one 6-inch dry valve and an actual test showed that it would take the water four minutes to reach a head 150 feet above the valve. Most of this time was taken in reducing the air pressure through one open head to a point that would allow the valve to trip. In a system installed under the present rules it should not take more than 20 to 40 seconds for the water to reach any head after it has opened.

Where more than one valve is needed in a building the system should be divided horizontally instead of vertically. In other words the basement, first and second floors might be on one valve and the third, fourth and fifth floors on another valve. If the system were divided vertically with half of each floor on one valve and the other half on the other valve, a fire starting near the center of a floor might open heads on one system and then spread to the section controlled by the other valve. This would necessitate the operation of the other dry valve, with the resulting delay, at a time when any delay might be quite serious. Where the systems are divided by fire walls this rule would not apply.

Air-filling Pipe. An air pump is necessary to pump air into the system. The connection from the air pump to the system should be made at the dry valve and there should be a shut-off and check valve in the air pipe close to the system. The check valve prevents the air in the system from leaking out through the air pump or

through any break that might occur in the air pipe behind the check.

Enclosure of Valve. The dry valve should be so located that it will not freeze. If in a cold building, it can either be in a pit or else in a frostproof closet. In any case the enclosure should be of sufficient size to give 2½ feet on all sides of the valve. The closet can be

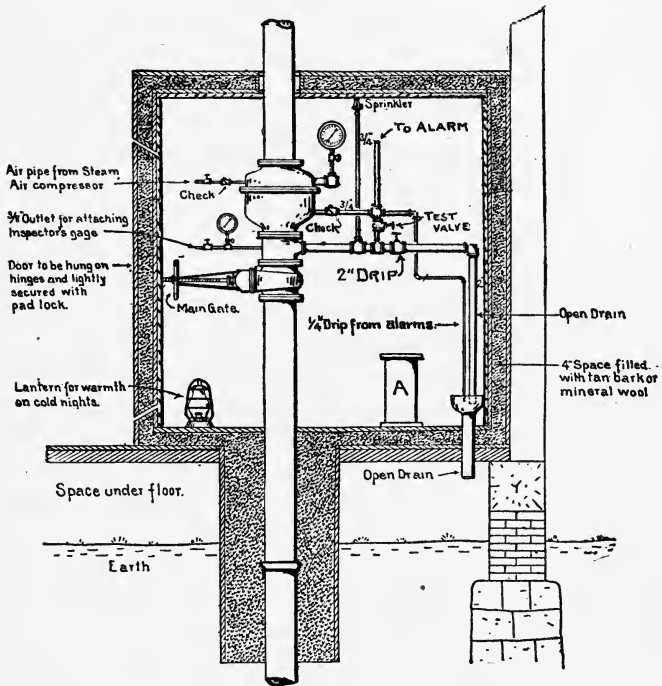

DRY VALVE CLOSET.

A, flanged dummy.

heated with steam, gas, electricity or a lard oil lantern. A sprinkler, connected to the main riser below the dry valve, should be located in the closet.

Test Pipes. A 2-inch test pipe is now required on the riser just below the dry valve so that the water

supply can be thoroughly tested. This is in addition to the drain pipe above the dry valve. This is of great importance for without it no adequate test can be made to prove that water in proper volume is in the pipes up to the dry valve.

Air Compressor. An air compressor or air pump should be provided of sufficient capacity to increase the air pressure in the system at least one pound in two minutes. With such a pump, it should not take over 60 minutes to pump up a system. With some of the pumps formerly furnished, it often took a day to do this and during the interval the system was out of commission. Steam or electrically driven pumps are preferable to power pumps as they are more reliable.

The air pump should draw its supply from some place where the air is dry and not too warm. Unless this is done, moisture-laden air, which will condense and may cause trouble, will be pumped into the pipes. It is often desirable to take the air from out of doors. A very good plan is to draw the air through a reservoir or tank of about 30 gallons capacity containing 10 to 15 pounds of granulated calcium chloride which absorbs the moisture and leaves the air very dry. The end of the suction pipe should be screened to prevent drawing in any foreign material.

Auxiliary Dry System. Where the larger part of a sprinkler system must be dry, it is desirable to pipe the entire equipment on the dry system; but where less than 25 per cent must be dry, a separate dry valve should be installed to control this section, and the rest of the system should be wet pipe. Show windows and stair towers come under this heading. There is always a temptation to shut off the sprinklers in such places during cold weather, but this is undesirable and should only be done in extreme cases and with the consent of the inspection department having jurisdiction. It is

particularly important to keep the sprinklers in show windows in commission at all times as there is considerable hazard there, especially at Christmas time, and a number of fires have been caused by the elaborate illumination installed in these windows.

In order to save the expense of a dry valve it is sometimes feasible to use an ordinary check valve, pumping up a heavy air pressure above it. This should only be done where there are but few heads involved and where the water supply is of steady and not of too heavy pressure. The air pressure must considerably exceed the water pressure in such a case but the time necessary for the water to reach a head is not excessive as the volume of air to be exhausted is small. The check valve like a dry valve should be primed with water to make it tight.

Flanged Dummy. A flanged dummy, or section of pipe of the same length as the dry valve, is required with each dry system. This is to be used to replace the dry valve in case the latter has to be sent away for repairs. If the repairs are made in mild weather the water can then be kept on the system until the valve has been replaced.

EARLY SYSTEMS

One of the first attempts to prevent freezing in a sprinkler system was in 1861 when *Osmund Williams* patented a non-freezing chemical solution to be used in sprinkler pipes. The *Harkness* system also used a similar solution.

In 1864 *Wm. Gilbert*, *Edwin Cooper* and *G. R. Webster* made a fusible cord of gutta percha, chloride of sulphur, sulphuret of antimony, copper bronze and naphtha. This melted at from 90° to 120° F. and was arranged so that when it fused it would release the hammer of an alarm and also open the water valve on a sprinkler supply pipe.

John W. Bishop of New Haven suggested a dry-pipe valve in 1879 and took out patents in 1881. This consisted of a vertically rising valve closing the water port. A stem on the upper side of the valve was clamped to an elastic diaphragm of a much larger area than the water valve. Water was allowed to enter the system above the diaphragm to a sufficient height to hold the valve closed by pressing on the upper side of the diaphragm. There was a by-pass containing a cock normally closed, extending from below the water valve to the space under the diaphragm.

A system of cords containing fusible links at short intervals was strung along the ceiling near the sprinklers and so arranged that when any link melted, a weighted lever connected to the cock was released. This opened the cock in the by-pass and allowed water pressure to enter the space under the diaphragm. This counteracted the pressure above the diaphragm and allowed the water pressure in the main pipe to open the water valve.

Another early system was the *Mackey*, installed by J. C. Mackey of Syracuse, N. Y., in conjunction with the sprinkler head of the same name. In this system a gate valve normally closed and with a weighted arm kept the water out of the system, no air pressure being used. There was an auxiliary thermostat system installed with a thermostat near each sprinkler. The weighted arm of the valve was held by an electrically operated tripping device connected to the thermostat system.

In case of fire a sprinkler opened and the thermostat near it also operated. This closed an electrical circuit through an electro-magnet and tripped the weighted arm. The valve was thereby opened and water allowed to enter the system.

Mr. Frederick Grinnell took out his first patent on a

dry valve in 1879. This consisted of a horizontal check valve seating vertically and with a stem running in guides. A system of levers was used to hold this valve securely closed. A small diaphragm in the lower part of the casting acted on a rod which was arranged to trip the levers. Air pressure pumped into the pipes above the check valve held this diaphragm down. When the air pressure was released the diaphragm, actuated by a weighted lever or spring, was forced up and this motion tripped the levers and allowed the valve to open. This valve was self-contained, except for an alarm attachment, and was far superior in principle to many that succeeded it.

The alarm connection consisted of a lever attached to the water valve and extending through a stuffing box to the outside. The movement of the check valve was used to trip a mechanical gong.

The first valve to be generally used was the Grinnell differential "bellows type" invented in 1885. The differential valve No. 12 which succeeded it in 1890 was very widely used — perhaps more so than any other valve, and the field experience was remarkably successful.

Amongst the other early dry systems was the *Gray*, first patented in 1884. This used an auxiliary system of pipes for the air pressure and was quite extensively installed. Mr. Gray patented seven other dry-pipe valves and systems between 1884 and 1902 but most of them had very limited use.

The Walworth Manufacturing Co. installed a limited number of dry systems but their valves were cumbersome and unreliable and they preferred to install wet-pipe equipments.

Many of the older valves were very unreliable and but few that have been in use for over twenty years can be considered efficient today. The valves made today

are very reliable when properly installed and carefully maintained. They all require careful supervision to see that water is kept drained from the pipes and sufficient air pressure maintained at all times.

REQUIREMENTS FOR DRY VALVES

The following are the more important general requirements which an approved dry valve should fulfill although a valve fulfilling them all is not necessarily satisfactory.

Should be strong and simple in design and construction and capable of withstanding 300 pounds pressure.

Should not cause excessive loss of hydraulic head.

Should not depend upon delicate adjustments and should not be subject to misadjustments as a result of wear, repair or reassembling.

Should have all working parts enclosed.

Should not be easily affected by corrosion, mud or pipe scale.

Should have an opening action giving direct relief to water valve.

Should not have an opening action traversing a pressure-retaining joint or fit.

Should trip between 6 and 14 pounds air pressure under service pressures between 50 and 120 pounds.

Should not trip from normal leakage at air or water seat; or if water pressure is entirely removed.

Should not have intermittent action after opening.

Design should be such that valve can be located close to a wall, floor or ceiling; is easy to repair or adjust; will not spill water when it operates; cannot be set unless correctly assembled; is not easily gagged; is not readily water columned; air pressure seats not likely to require regrinding.

ALPHABETICAL LIST OF DRY VALVES

ASSOCIATED

Manufactured by *Associated Automatic Sprinkler Co.*,
Philadelphia, Pa.

A-1915. Mechanical valve. There were two swing clappers in the main water way, the lower clapper being held down by a series of levers and weights. The last lever of the series rested on the under side of an auxiliary air check, located inside of the main casting. Most of the levers were located in an offset accessible through a swinging door.

Construction. The water clapper (8) is held closed by yoke (14) which has bearing points on its two outer ends upon which rest the toes of the bifurcated bell crank lever (15). The ball joint pin (16) passes through one end of the bell crank lever (15) and is securely riveted in place. This ball joint pin fits into a recess in the inner end of the atmospheric valve (12) and is held in place by the retaining plate (17) which is securely bolted to the inner face of the atmospheric valve. The outer end of the atmospheric valve stem (12) rests in a recess in the adjusting screw (23), which adjusting screw is threaded into and carried by hook lever (18); hook lever (18) at its lower end bears against a partition in weight lever (19), which lever carries weights (22). Weight lever (19) has a partition against which bears the toe of the tumbler (20) and tumbler (20) is fitted with a recess into which fits the lower end of strut (21) while the upper end of strut (21) fits into a recess in a lug on auxiliary air clapper (10). The yoke (14) is carried on the same pin as water clapper (8) while the bell crank lever (15) and weight lever (19) are carried by round pins, and hook lever (18) and tumbler (20) are carried by knife-edge pins to prevent binding.

Operation. The opening of a sprinkler head in the system releases the pressure in the lines until it falls below twelve pounds, when the weights (22) overcome the pressure on valve (10) and release hook lever (18) which causes atmospheric valve (12) to close seat (13),

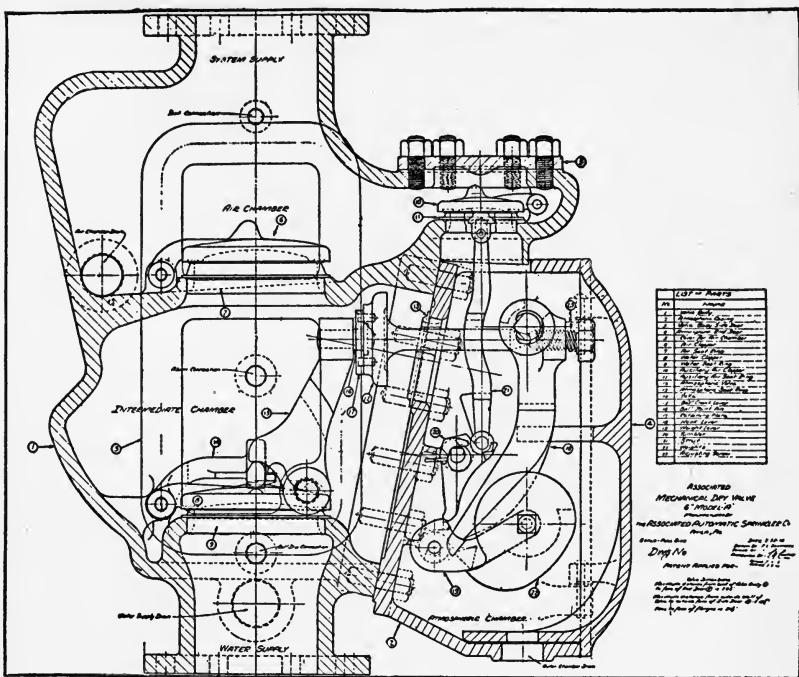

ASSOCIATED DRY VALVE (Section).

and releases lever (15) and yoke (14) allowing water pressure to open water clapper (8) and main air clapper (6) and admit water to the sprinkler lines. The water entering the intermediate chamber passes through alarm connection to alarm devices and gives immediate notification of the operation of the sprinkler.

Approved by the Underwriters' Laboratories, May, 1915, in 6-inch size. Withdrawn 1916, manufacture discontinued.

Rating: *Satisfactory.*

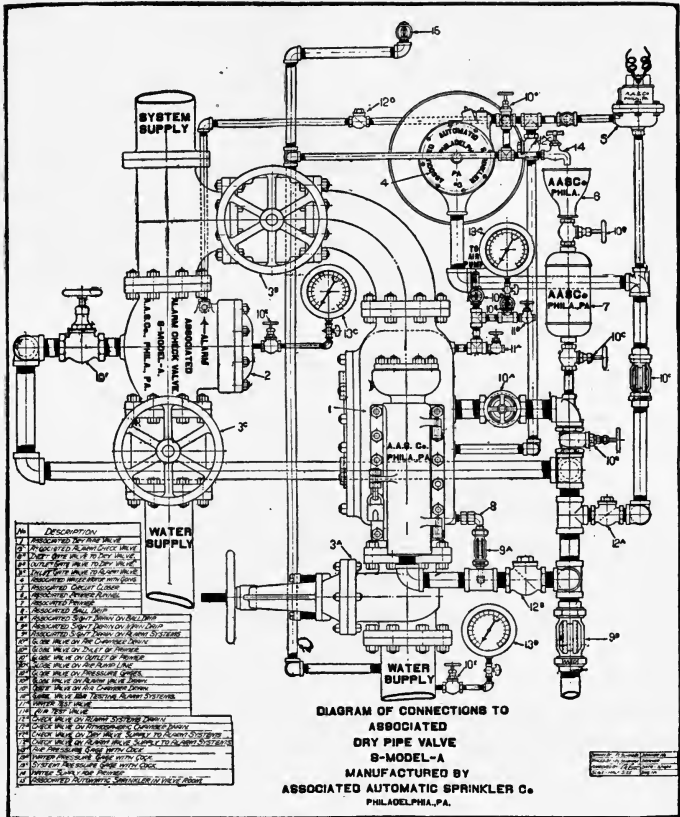

BROWN

Manufactured by the *Automatic Fire Alarm & Extinguisher Co., New York.*

Mechanical valve. Opinion of the Device and Material Committee of the National Fire Protection Association, November, 1904.

1. Liable to be inoperative under ordinary service conditions.
2. Has opening action failing to give direct relief to water valve.
3. Has opening action traversing a pressure-retaining joint or fit.
4. Working parts not satisfactorily enclosed.

Present rating: *Unreliable.*

CATARACT

Automatic Sprinkler Equipment Co., Chicago, Ill.

1905. This was a valve of simple construction and of the mechanical type. There were two vertical clappers seating on horizontal valve seats with an intermediate space between. The lower or water clapper was held closed by a stem bearing against two hinged levers forming a toggle joint. The upper ends of these levers rested in a cup-shaped depression in the base of the upper or air valve. The leverage was such as to cause the valve to trip at very low air pressure: namely, 2 pounds air under 44 pounds water, and 5 pounds air under about 85 pounds water.

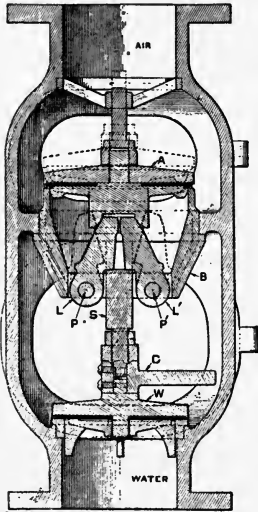

CATARACT DRY VALVE.

(Section.)

- A, air clapper.
- W, water clapper.
- S, stem.
- L, levers.

Criticized by the Underwriters' Laboratories in February, 1907, as follows:

1. Low trip point.
2. Adjusting mechanism for water valve.
3. Friction loss.
4. Effects of corrosion.
5. Features of design and construction.

Third sample, October, 1907, criticized by Underwriters' Laboratories as follows:

Effects of compression screw on trip point renders valve liable to water column on low pressures and necessitates excessive air pressures on high-service pressures.

Rating: *Unreliable.*

CLAPP

Made by *Clapp Automatic Fire Extinguisher Co., Chicago.*

1-1890. Mechanical type. Angle valve with water clapper seating horizontally. Stem on upper side of water valve passed through top of casing, a tight joint

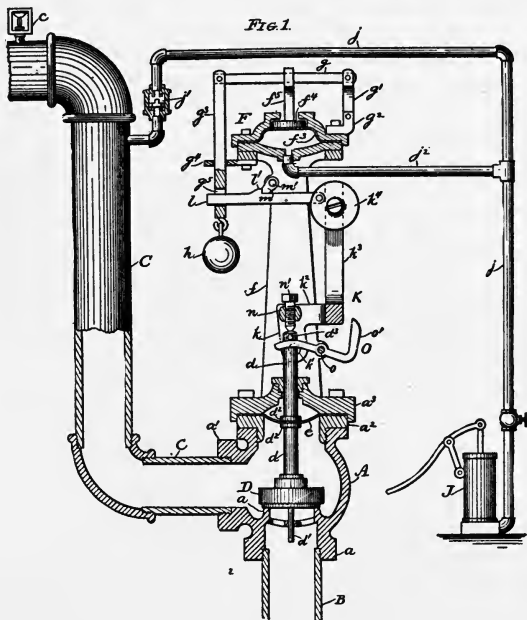

CLAPP DRY VALVE 1.
(Part section.)

D, water clapper. *d*, stem. *e*, diaphragm. *g*, *m*, *k*, levers.
*f*³, tripping diaphragm.

being made by use of a flexible diaphragm. Stem held down by a system of levers. When the air pressure dropped, a diaphragm normally held up by the air pressure fell, thus allowing a weighted lever to drop and trip the levers. There was no air check and the air pressure rested on the upper side of the water valve.

But few were made.

Opinion of the Device and Material Committee of the National Fire Protection Association, 1904:

1. Liable to be inoperative under ordinary service conditions.
2. Easily affected by exterior corrosion.
3. Operating action does not give direct relief to water valve.

Present rating: *Unreliable.*

2-1891. Piston type. Angle valve with vertical air check, and horizontal water valve opening against water

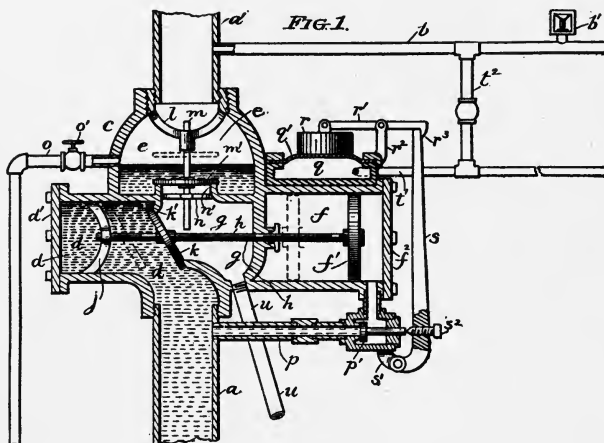

CLAPP DRY VALVE A.

(Section.)

k, water clapper. *f*, piston. *m*¹, air clapper. *p*, by-pass to space behind piston. *p*¹, valve in by-pass. *q*, diaphragm. *r*, *s*, levers tripping valve in by-pass.

pressure. There was a piston of slightly larger area than the water valve connected to the valve by a rod. The sprinkler supply pipe entered the device between the water valve and the piston. A by-pass admitted water pressure to the further side of the piston and as the pressure was balanced on each side of the piston, the water pressure held the main valve closed. When the air

pressure was released, a diaphragm connected to a weighted lever was allowed to drop. This lever opened a drip pipe in the space back of the piston thus releasing the pressure there. The water pressure acting with more force on the piston than on the valve pushed the piston back and opened the valve. Made up to 1893.

Underwriters' Laboratories Report, 1903:

Thirteen features criticized.

Present rating: *Unreliable*.

Note: A slight modification of this valve is shown in Cut A.

CLAYTON

Ernest S. Clayton, Newark, N. J. Made by Independent Fire Extinguisher Co., Newark, N. J.

1906. This was a differential valve of the balanced type. It consisted of two valve discs held together by a rod, the upper disc being somewhat larger than the lower one. The water entered an intermediate space between the two discs and held them up, the pressure being greater on the upper disc. There was a small water way through the upper disc closed by a loose stopper held in place by a diaphragm. The air pressure in the system ordinarily held the stopper in the opening. When the air pressure was reduced the stopper was released and water entered the chamber above the valve. This created an equal pressure on the upper and lower sides of the upper disc, and the water pressure acting on the lower disc (then unbalanced) opened the valve.

Underwriters' Laboratories Report, May, 1907.

Features criticized:

1. General principle of operation.
2. Necessity of delicate adjustment.
3. Danger of water columning by leaking at water seat.
4. Delay in action.
5. Features of design and construction.

Never used so far as known.

Present rating: *Unreliable*.

CROWDER

Crowder Bros., St. Louis, Mo.

1-1907. Mechanical valve. Large casting with swing check valve for air seat and a similar check for water seat, both seating horizontally. The water check held in place by a series of external and internal levers and weights was tripped by the release of air pressure in a small air pot.

Underwriters' Laboratories Reports, January, 1907, and September, 1911.

Various criticisms.

2-1913. Modified form. Features criticized:

1. Ease of gagging.
2. Improper safeguard against leaving intermediate chamber open.
3. Failure to open.
4. Trip or operating point.
5. Effects of corrosion.
6. Other features of design and construction.

Never used so far as known.

Rating: *Unreliable.*

DIXON

J. H. Dixon, Erie, Pa.

Underwriters' Laboratories Report, 1904, on undeveloped device.

Practically all features criticized.

Never used so far as known.

DODGE

Dodge Manufacturing Co., Mishawaka, Ind.

Mechanical valve. Water clapper was held in place by a system of levers and an inverted auxiliary air clapper. When the air pressure was released the air

clapper dropped, thus releasing a weighted lever connected with the water clapper.

Underwriters' Laboratories Report, April, 1903. Six features criticized.

March, 1904. One feature criticized.

Never used so far as known.

EVANS

Merchant & Evans Co., Philadelphia, Pa.

A or Model 3-1915. Mechanical valve. There were two swing check valves in the main water way. An auxiliary air valve in the main casting near the upper check held in place a series of levers and weights, which in turn held the lower clapper closed when the valve was in normal condition.

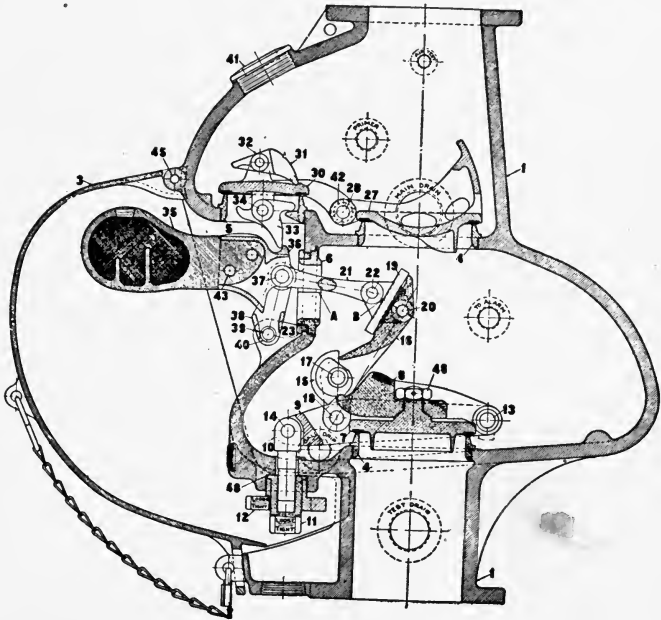

EVANS DRY VALVE.
(Section.)

**INSTRUCTIONS FOR SETTING DRY THE "EVANS"
DRY PIPE VALVE**

1. Loosen lock nut (12) (turn to left) very slightly ($\frac{1}{2}$ turn only) and loosen adjusting nut (11) until center line "B" of intermediate clapper (19) is opposite center line "A" of intermediate seat (6).

2. Open main cover (2) and carefully clean water and air seats (4), also auxiliary (5) and intermediate seat (6), being especially careful not to bruise or damage the seats in any way. Likewise clean the companion clappers of these seats (7, 27, 30 and 19). Be sure that no grit or dirt of any kind remains to prevent the clappers from seating properly. Place clappers (7, 27 and 30) on their respective companion seats. Replace main cover (2) and bolt securely.

3. By using primer be sure there is at least 12 inches of water above the air clapper (27), and then pump air pressure of 40 lbs. into the system.

4. Open each drain valve on system and allow air pressure to escape, blowing out any water remaining in the system.

5. When the system is entirely drained of water, replace 40 lbs. of air pressure which is sufficient to safely retain any available water pressure. Caution. Air pressure should not exceed 40 lbs. or drop below 30 lbs.

6. Raise ball weight cover (3) and lift ball weight (35) sufficiently to engage lever of ball weight (36) with trigger (33) of auxiliary clapper (30).

7. Open slowly the controlling gate valve in water supply pipe, and with a 12-inch wrench slowly tighten (turn to right) adjusting nut (11) until main water seat (4) shows no leak which is noticeable through ball drip.

8. Tighten (turn to right) lock nut (12). Caution. Care should be taken not to put more tension on

adjusting nut (11) than is necessary to prevent water leaking past main water clapper (7).

The dry pipe valve is now set complete and ready for operation, excepting the following features which require special attention.

1. Close and lock ball weight cover (3).
2. **Most Important.** Open wide the controlling gate valve in supply pipe.

INSPECTION OF "EVANS" DRY PIPE SYSTEM WHEN DRY PIPE VALVE IS SET

1. Open $\frac{1}{2}$ -inch air test valve and see that system is free from water to the level of this valve.
2. Open water test cock, making sure that the air clappers are primed with water.
3. Open water test valve below water seat of dry pipe valve to insure that controlling gate is wide open and water supply is not frozen.

TEST OF "EVANS" DRY PIPE SYSTEM WHEN DRY PIPE VALVE IS SET

1. Close controlling gate valve in water supply pipe.
2. Open drain valve and allow air pressure to escape, then the dry pipe valve will trip and operate as in case of fire, but will not allow water into the system.
3. Close drain valve, reset dry valve as per instructions, and open main controlling valve.

Field experience very limited.

Approved by Underwriters' Laboratories, September, 1915. Manufacture discontinued in 1916. See Globe 3.

Rating: *Satisfactory*.

GLOBE OR GARRETT

C. B. Garrett, Minneapolis, Minn. Assigned to *Globe Automatic Sprinkler Co.*

A-1906. Mechanical valve with two clappers. Upper or air clapper seated at an angle of about 45 degrees.

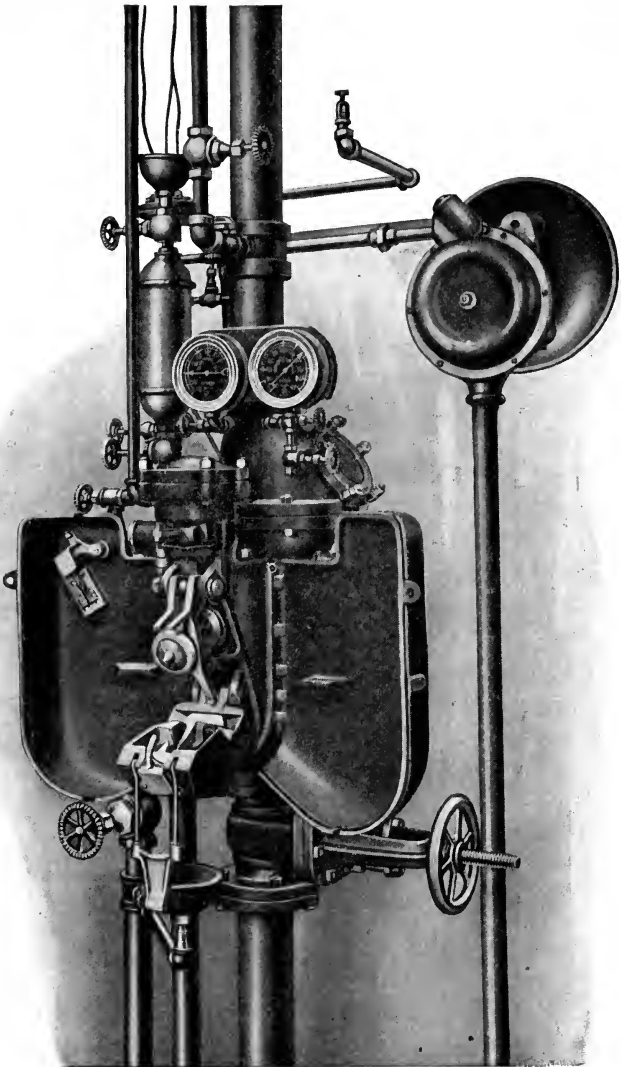

GLOBE DRY VALVE "B."
 Interior View. Tripped.

Lower or water seat was horizontal. Lower clapper held in place by a long hinged lever bearing against upper clapper.

Several laboratory reports between July, 1910, and February, 1913.

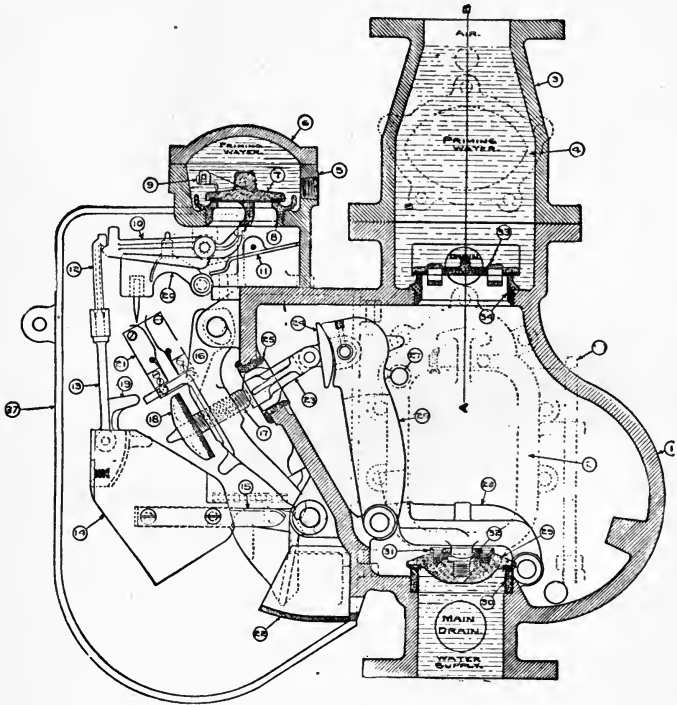

GLOBE DRY VALVE "B."
(Section.)

B-1913. This consists of a casting containing an air and a water clapper. There is also an auxiliary air check located in an offset. The main water clapper is held closed by a system of levers connected to the auxiliary air check.

Criticized by the Underwriters' Laboratories in August, 1913, as follows:

1. Strength of parts.
2. Erratic action of parts.
3. Ease of gagging.
4. Liability of improper adjustment of parts and other features of design and construction.

Description. 29, water clapper. 33, air clapper. 7, air pot clapper. 28, compression lever. 26, 23, 16, 15, 14, 13, 12, 10, levers holding air clapper in place.

Rating: *Not standard.*

D-1914 Garret Model. Mechanical valve similar to type B except as follows:

1. Hand-hole cover plate hinged at the bottom and the cam rod eliminated.
2. The method of fastening the atmospheric valve hinge pin changed.
3. The tripping lever guard cast with the air pot.
4. The weight lever changed in shape.
5. The weight bail and rods eliminated and a bronze weight bail substituted.
6. The drip spout eliminated and a cast iron apron bolted to the valve body to receive the weight as it falls.
7. The air pot altered in shape.
8. The cast iron weights made in one piece.
9. The adjusting screw provided with $9\frac{1}{2}$ instead of $8\frac{1}{2}$ threads to the inch.
10. The setting lever slightly altered in shape and the hole for adjusting screw tapped to receive a screw having $9\frac{1}{2}$ threads to the inch.

Approved by the Underwriters' Laboratories, April, 1915. Manufacture discontinued in 1916.

Rating: *Satisfactory.*

Globe Model 3-1916. Globe Automatic Sprinkler Co., Philadelphia. This is the same devise as Evans A, Model 3, but is now made by the Globe Automatic Sprink-

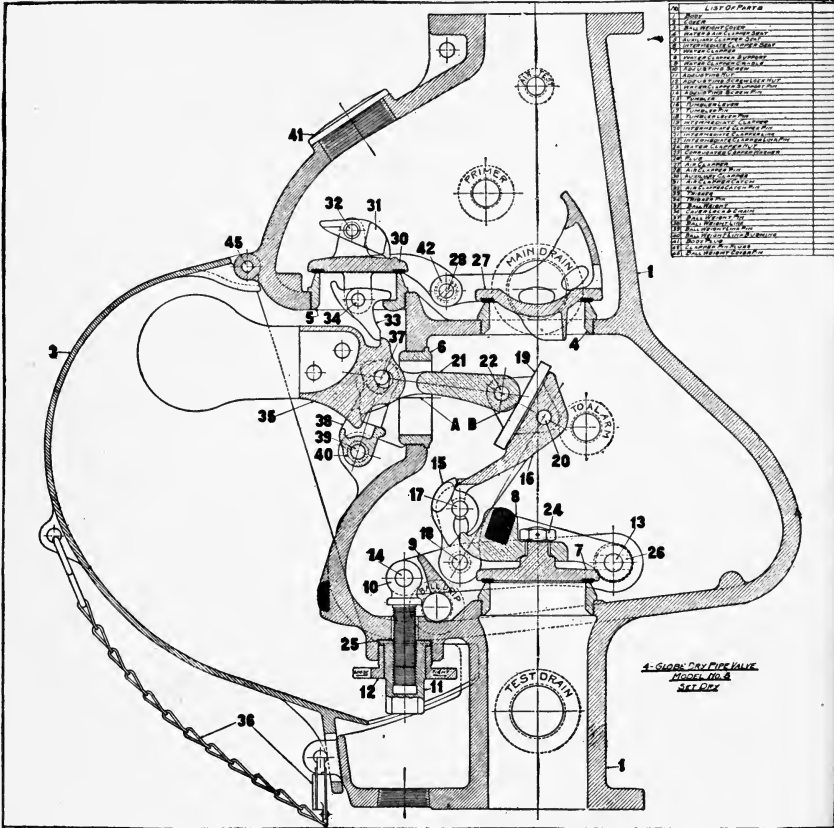

GLOBE DRY VALVE MODEL 5.

ler Company. Approved by the Underwriters' Laboratories, 1916, and by the Associated Factory Mutuals.

Withdrawn from approval by Underwriters' Laboratories, March, 1917.

Manufacture discontinued. After listing, some ques-

tion developed regarding strength of operating mechanism and reliability in operation.

Rating: *Generally satisfactory.*

Model 4-1916. Approved by Associated Factory Mutual Fire Insurance Companies and installed in their risks pending the approval of Model 5.

Model 5-1917. Same as Model 3, except for the following minor changes:

The tumbler hinge pin (17) has been increased in diameter from $\frac{1}{2}$ to $\frac{3}{4}$ of an inch.

The tumbler (15) changed to accommodate the large hinge pin and more metal added to this member, at the point where it bears against the tumbler lever (16).

The water valve support (8), the adjusting nut (11), the atmospheric valve link (21), and the ball weight link (38) changed from phosphor bronze to magnesium bronze.

Two toes or bearing surfaces added to front end of atmospheric valve (21), and bearing surfaces added to ball weight link (38).

The off-center distance of toe of water valve support increased.

Approved by the Underwriters' Laboratories in 4-inch and 6-inch sizes, March, 1917.

Rating: *Standard.*

GRAY

Manufactured by *Gray Sprinkler Co., New York.* Installed by *Insurers Automatic Fire Extinguisher Co., New York.*

1-1884. Mr. Frank Gray of New York patented a dry-pipe system in 1884 in which an auxiliary system of small piping was used for the air pipes. This piping was run parallel and close to the sprinkler piping and small fusible plugs were inserted in this piping near each sprinkler. Air was pumped into the smaller system of

pipes and this pressure acted upon a differential valve in the main riser. The pipe running to the sprinklers connected to the intermediate space of the differential valve, the valve being in the form of two pistons with a travel of several inches.

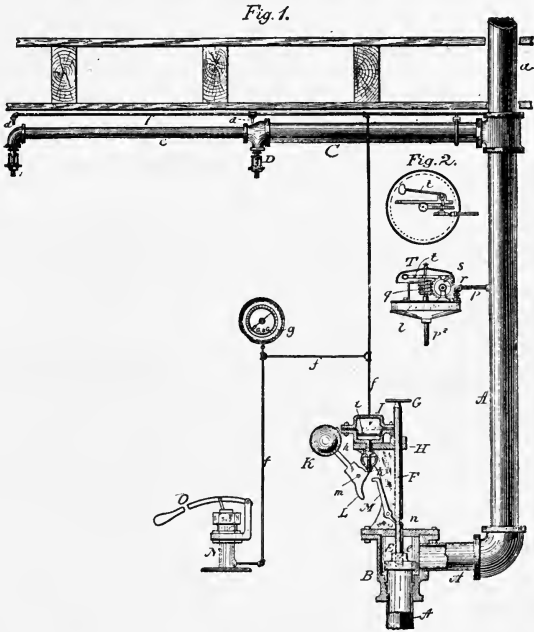

GRAY DRY SYSTEM 2.

D, sprinkler. *d*, fusible plug in small piping. *B*, angle valve.
M, m, levers holding valve closed. *i*, diaphragm.

2-1886. In 1886 and 1887 the releasing device was modified and instead of a differential valve, an angle valve held closed by a series of levers attached to a diaphragm was used.

Both systems used to a considerable extent. Now practically obsolete.

Device and Material Committee opinion, 1904:

1. Opening action does not give direct relief to water valve.
2. Opening action traversing a pressure retaining joint.
3. Working parts not satisfactorily enclosed.

Present rating: *Unreliable.*

GRINNELL

Manufactured by *Providence Steam & Gas Pipe Co.*

1-Bellows, 1885. This was a differential valve. Water and air clappers held together by a rod which also acted as a guide. Water clapper was metal seating on a horizontal metal seat. Air clapper attached to the casting by rubber bellows giving a total area about eight

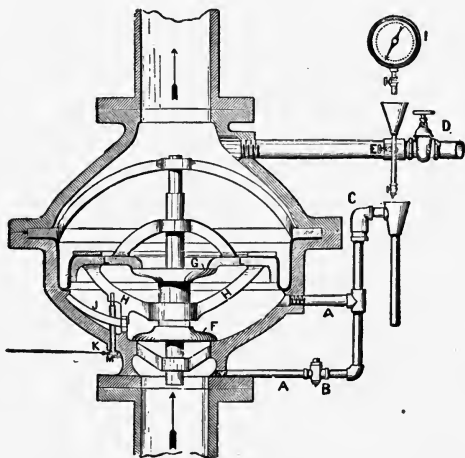

GRINNELL "BELLOWS" DRY VALVE.
(Section.)

See description, page 202.

times that of the water valve. The rubber bellows was subject to deterioration and sediment was apt to collect in fold of same. Used successfully for several years. Now practically obsolete.

Present rating: *Unreliable.*

Description. The water clapper *F* is attached to a spindle carrying the air clapper *L* seating on *G*, both seats being metal to metal. There is a large rubber diaphragm clamped to the edge of the air valve and also to the outer casting. This is folded like a bellows to allow considerable movement of the air clapper. The spindle runs in four guides and can be raised until a shoulder comes in contact with a stop, shown near the top of the device. There is a single step latch at *J* to hold the valve up when it opens. *M* is an alarm attachment operating at *K*. There is an automatic drain for the intermediate space, an air test pipe at *E*, and a cup for priming the space above the valve with water.

The differential is due to the difference in area between the water clapper *F* and the air clapper *L*, including the horizontally projected area of the rubber diaphragm.

When the valve opens, the water and the air clappers move upwards until the spindle reaches the stop, the rubber diaphragm being distorted to allow this motion. The water enters the system by flowing around the water clapper *F* and the air seat *G*.

Note: Eleven minor changes were made in this valve between 1885 and 1890 but they were mostly of minor importance. These constitute the eleven types of valve made prior to the so-called No. 12.

GRINNELL

General Fire Extinguisher Co., Providence, R. I.

12-1890. Differential valve. Air and water valve in one flower pot shaped casting. Water seat metal to metal. Air seat consisted of flexible rubber ring clamped to edge of valve. Latch actuated by spring held up the valve when it once opened and prevented columning. Electric alarm connection consisted of metal diaphragm attached to plug which was screwed to casing at intermediate space. This style of electrical circuit closer

the air seat to give flexibility. The latch *D* operated by a heavy spring held the valve up when it opened and prevented water column. There was a step on this latch part way up and the valve could be latched by this step or by the top of the latch depending upon how much it opened. A hand-hole plug *J* could be removed for cleaning the water seat or examining the intermediate space. The differential was about 7 to 1. There was an automatic drain in the intermediate chamber to take care of any water that might leak past the water valve.

To set the valve the water was shut off and hand-hole plug was removed. After wiping the water seat clean the plug *E* was removed, the latch *D* was pulled out and the valve allowed to drop onto its seats. Priming water was then poured in above the air seat. The air pressure was then pumped in and the water valve opened.

Tests. *Valve should be tested as follows:*

1. For water column by opening test pipe above the valve to see if any water has accumulated. If so it should be drained off.
2. For strength of spring in latch *D*. This is done by unscrewing the small plug covering the latch and pulling on the ring attached to the latch to see that it is in working order. Some trouble has occurred from defective latches.
3. Free way. Open hand-hole plug *J* to see that there is no obstruction in the intermediate space which would prevent the valve from opening.

Note: In 1897 the new circuit closer consisting of a diaphragm operating a knife switch was used.

GRINNELL STRAIGHTWAY

General Fire Extinguisher Co., Providence, R. I.

A-1907. Differential type. Lower part of valve is in the form of a gate valve and is attached to a piston working in a horizontal cylinder. When the valve opens this part is pushed to one side by the water pressure,

leaving a free way. Cylinder of bronze. Upper part of body of valve lined with Babbitt metal.

Rating: *Approved.*

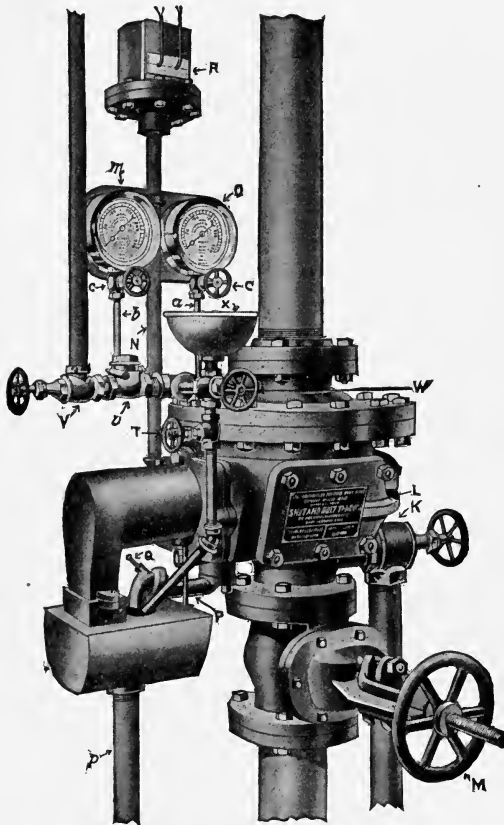

GRINNELL DRY VALVE.
Straightway Type.
General view showing fittings.

B-1910. Same as type A except that cylinder and valve body are of iron, copper plated on the inside.

Rating: *Standard.*

Description. The valve J, J, F, F, has a water seat at *F* and an air seat at *G*. The upper part of the valve is attached to a flexible diaphragm *B* clamped between two parts of the valve body. A piston *D* is attached to the movable part of the valve by a rod. This piston fits loosely in a cylinder made of iron, copper plated and

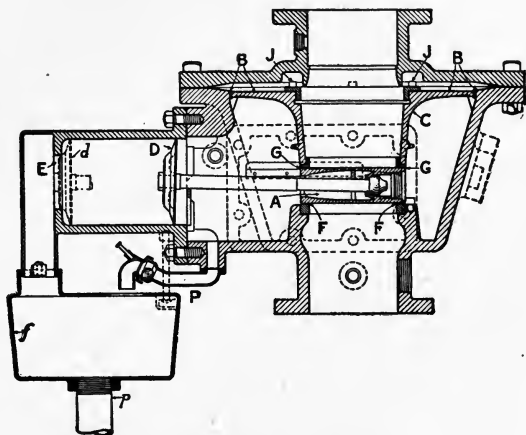

GRINNELL DRY VALVE.

Straightway Type.

(Section.)

tinned. There is a vent *E* at the end. There is a drain pipe *P* connecting with the intermediate space and having an automatic ball drip on the end. When the air pressure on the diaphragm and air valve is sufficiently reduced, the water pressure will force open the valve a small amount. The water entering the intermediate space will fill it and then force the piston *D* to the further end of the cylinder where it closes the vent *E*. This carries with it the valve disc, leaving a free water way through the system.

Tests.

1. Open draw-off pipe to test for water column.
2. Open hand-hole plate to intermediate space occasionally to see that there are no obstructions and that water valve is tight.

GRINNELL

General Fire Extinguisher Company, Providence, R. I.

C-1916. This is a differential valve of the swinging clapper type. The air and water valve both swing on the same pivot but are set at an angle with each other,

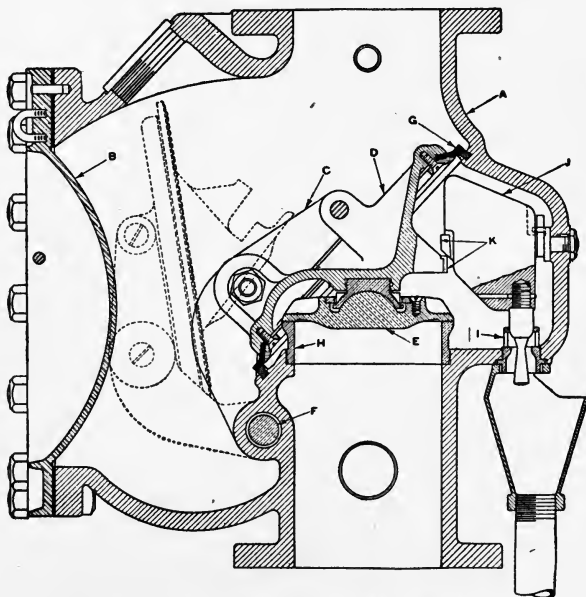

GRINNELL DRY VALVE MODEL C.
(Section.)

- A, main casting. B, hand-hole plate. C, arm carrying clappers. D, air clapper casting. E, water clapper. F, clapper arm pin. G, rubber ring on air clapper. H, water valve seat ring. I, automatic drip valve. J, latch weight. K, latch.

thus making a smaller and more compact valve. There is a hemispherical seat that transmits pressure from air valve to water valve between the center of rotation and the line of action of the air force. This results in a slight movement of the air valve about the hemispherical seat, which is arrested by the clapper arms coming in contact with the pin which is the axis of rotation.

The differential is about 6 to 1. The air valve has a rubber ring seating on a babbitt metal seat ring. The water valve is bronze to bronze. The latch is in the form of a weight which normally rests on a "nose" or projection between the two valve discs. The automatic valve which drains the intermediate space is attached to the latch weight and is held off its seat when the dry valve is set. When the valve operates the weight drops and the drip valve is thus closed.

The electric and rotary gongs are piped to the intermediate space as in the older types.

Approved by the Underwriters' Laboratories and Factory Mutuals in 1916.

Rating: *Standard*.

HIBBARD

1-1894. Made by *American Fire Extinguisher Co., Chicago*.

Differential type. The air check seated on a flexible spun brass seat and held a small water valve on its seat. When the air pressure was released, the water flowing through the small valve relieved the pressure on the upper side of a double-seated water valve. This latter valve was then raised by the water pressure in the system opening the main water way.

Only about 100 made. Manufacture discontinued in 1900.

Opinion of Device and Material Committee, 1904:

1. Susceptible to internal corrosion.
2. Dependent upon delicate adjustment.
3. Liable to permit excessive air leakage.
4. Cannot be set without risk of water damage

Present rating: *Unreliable.*

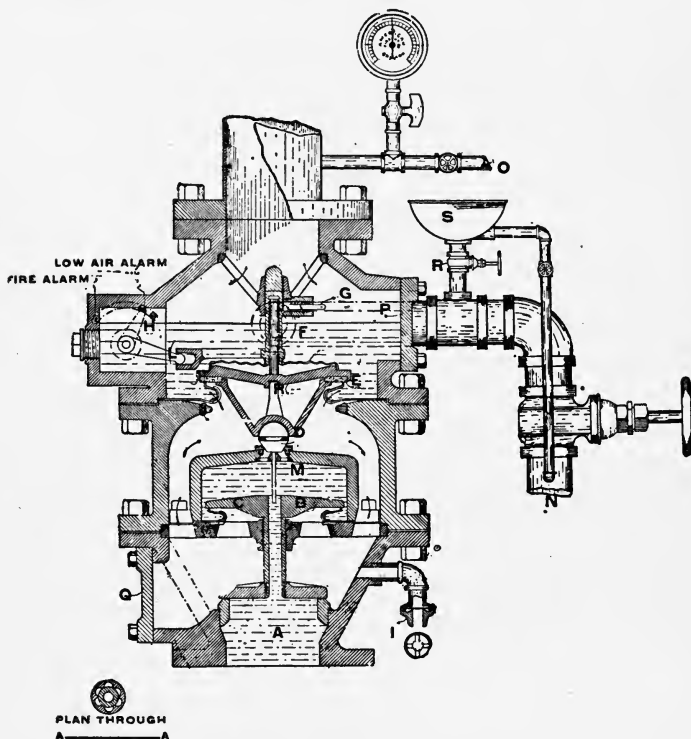

HIBBARD DRY VALVE 1.

(Section.)

A, B, C, water valve. M, small water valve held in place by air valve E. N, draw off pipe. S, priming cup.

2-1898. Made by *National Fire Extinguisher Co., Kansas City, Mo.*

Differential counterweighted valve.

Opinion of Device and Material Committee, 1904:

1. Difficult to set without producing water column.
2. Subject to disablement from back slap.
3. Adjustment easily destroyed by minor repairs.

Manufacture discontinued in 1901. Very few in service.

Rating: *Unreliable*.

3-1898. Made by *Mallers, Allen, Fraser & Co., Chicago, Ill.*

"Pile driver" type. This consisted of two swing checks seating horizontally in the main water way with an intermediate space between. The lower or water check was held closed by a lever extending through a hole in the casing to the outside and pivoted to a vertical rod. There was a large weight enclosed in a cylindrical casing and sliding on this rod. When the valve was set, this weight was held up by a lever connected to a small auxiliary air valve. When the air pressure was released the weight fell and striking the end of the water valve lever opened this valve.

Over 100 made. Manufacture discontinued in 1900.

Opinion of Device and Material Committee, 1904:

1. Liable to be inoperative under service conditions.
2. Opening action fails to give direct relief to water valve.

Rating: *Unreliable*.

4-1909. *Geo. E. Hibbard, Chicago.*

Differential type. Plans submitted in December, 1909, and criticized by Underwriters' Laboratories. Revised plans submitted, 1911. No finished valve submitted. Never used so far as known.

HIGGINS

Kellogg-Mackay-Cameron Co., Chicago.

Opinion of Device and Material Committee, 1904:

1. Liable to be inoperative under service conditions.
2. Opening action not positive under high-service pressure.
3. Opening action fails to give direct relief to water valve.
4. Opening action traverses a pressure retaining joint.

But few made. Manufacture discontinued in 1901.

Rating: *Unreliable.*

IDEAL

Ideal Automatic Fire Extinguisher Co., Philadelphia.

"Ever ready" dry-pipe valve. Plans examined and criticized January, 1912, and March, 1913, by Underwriters' Laboratories. No working device submitted to date.

IDEAL

Patented by *John H. Derby, Boston, Mass.*

1-1899. Mechanical valve. Water clapper held closed by toggle-joint levers bearing against a spindle and attached to air clapper. Air clapper of larger area than water clapper and of inverted type.

2-1903. Differential valve. Bronze double-seated valve placed in an inverted position, the lower or larger area being held up by air pressure. A swing check valve kept the air out of the intermediate space.

Report by Underwriters' Laboratories, January, 1906.

Features criticized:

1. High trip point.
2. Arrangement for outside connections.
3. Difficulty of repairs.
4. Weakness of parts.
5. Features of design and construction.

3-1906. Mechanical valve with two horizontally seating swing checks. Upper or air check held the lower check closed by means of a lever and a strut.

None of the types were ever put on the market.

INDEPENDENT

Independent Fire Sprinkler Co., Chicago, Ill.

1902. Mechanical valve. Vertical check valve held in place by wedge. A small auxiliary air valve held a train of levers outside the valve casing in position. These levers were released when the air pressure dropped,

thus releasing a heavy weight. This gave a threaded spindle a quarter turn, thus pulling out the wedge so that the water valve could open.

Underwriters' Laboratories Report, March, 1902.
Features criticized:

1. Effects of water column.
2. Opening movement.
3. External operating parts.
4. Internal sliding parts and complication of parts.

Rating: *Unreliable.*

INTERNATIONAL

International Sprinkler Co., Philadelphia, Pa.

1900. Differential.

Patented by J. C. Scott, August, 1900. This was a swing check valve seating at an angle of about 45 degrees. There was a large groove or intermediate space in the valve seat giving a differential of 4 to 1. An O. S. & Y. gate valve was so placed that the stem would hold the check closed when screwed down. This was used in setting the valve. This was omitted in later type. A

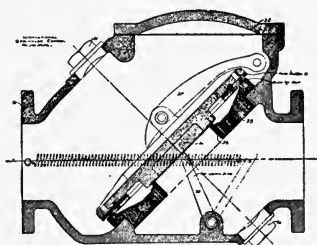

INTERNATIONAL DIFFERENTIAL
DRY VALVE.
(Section.)

A latch operated by an external spring was used to hold the valve open when it tripped.

Opinion of Device and Material Committee, 1904:

1. Subject to injury from back-slap.
2. Has opening action involving traverse of a pressure retaining joint.
3. Unduly subject to water hammer.

But few made. Manufacture discontinued in 1901.

Present rating: *Unreliable.*

Model No. 1-1901. Mechanical valve. There were but 32 of this model made, this number being replaced almost immediately by Model No. 2. The valve had the general arrangement of parts as seen in the present valve, with the following exceptions:

1. The hand-hole cover giving access to air check was elliptical in form, and located at the back of valve immediately over water inlet.

2. The hand hole giving access to intermediate space was covered by a triangular plate fastened by stud bolts to the body, but not attached by hinge or other shackle.

3. The tripping mechanism was in the main as in the present valve, except that lever No. 8 (hook) was not double as in the present valve, but made of a single member and was located sufficiently far to one side of lever No. 7 so as not to interfere, the stress screw operating through a lug on one side of "hook."

4. Covers or doors protecting external working parts were formed of sheet iron.

Rating: *Doubtful.*

Model No. 2-1902. (*Some patterns marked Evans Model No. 2.*)

Mechanical valve. This valve was provided with the present type of "hook," composed of two members, with a slot between, with the compression screw operating through a web connecting the two members, while the external parts were protected by cast-iron doors, as in the present type.

Tested by Underwriters' Laboratories, 1902. Withdrawn from list, June, 1907. Criticisms: — Use of hand-book plate which may be left off thus leaving equipment crippled, weakness of parts, undue influence of compression screw on trip point.

Field experience generally satisfactory.

Rating: *Not standard. Generally satisfactory.*

Model No. 3. This model was never manufactured, always remaining in the experimental stage. Its one distinguishing feature consisted of a cored channel, extending between the interior of the air check chamber to the wall of the main casting immediately under the finished surface of the inspection plate and gasket, the object being to prevent setting of valve without properly attaching the inspection plate.

Model No. 4-1908. Vertically seating water valve held in place by a system of levers and weights, the last lever bearing upon a depression in the lower side of air clapper. Air valve a swing check seating horizontally. When the air pressure is released the leverage forces the air clapper up, thus tripping the system of levers and allowing the pressure in the supply pipe to open the water check. Differs from previous model in that the hand hole to the air check chamber and the one to the intermediate chamber are covered with the one plate, attached to the body by stud bolts and loosely hinged to same. A section of the air check chamber was enlarged to permit the air clapper to swing completely out of water way.

Approved by Underwriters' Laboratories and Factory Mutual Insurance Cos.

Rating: *Standard.*

Description. The water supply enters horizontally and is held back by a vertically seating valve (12). A swing check seating horizontally holds the air pressure back from the intermediate space. This is primed with water to the level of the draw-off pipe. The water valve is held in place by the horizontal lever (7) adjusted by the set screw. The horizontal lever is connected with the curved lever (8) and this holds up a pivoted weight (6). This weight is held up by a vertical lever (10) bearing directly on the under side of the air clapper (13) and at the lower end on a short lever (9). Both clappers are metal to metal.

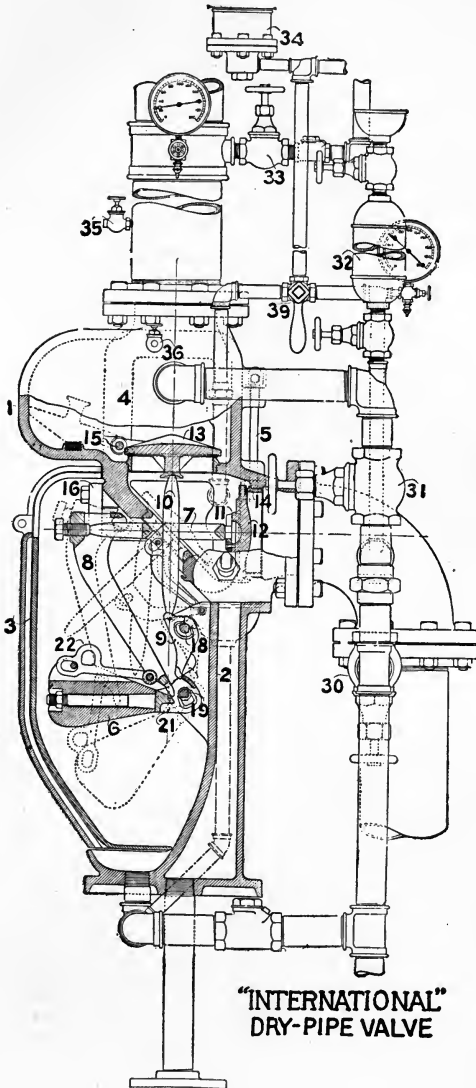

INTERNATIONAL DRY-PIPE VALVE 4.
(Section.)

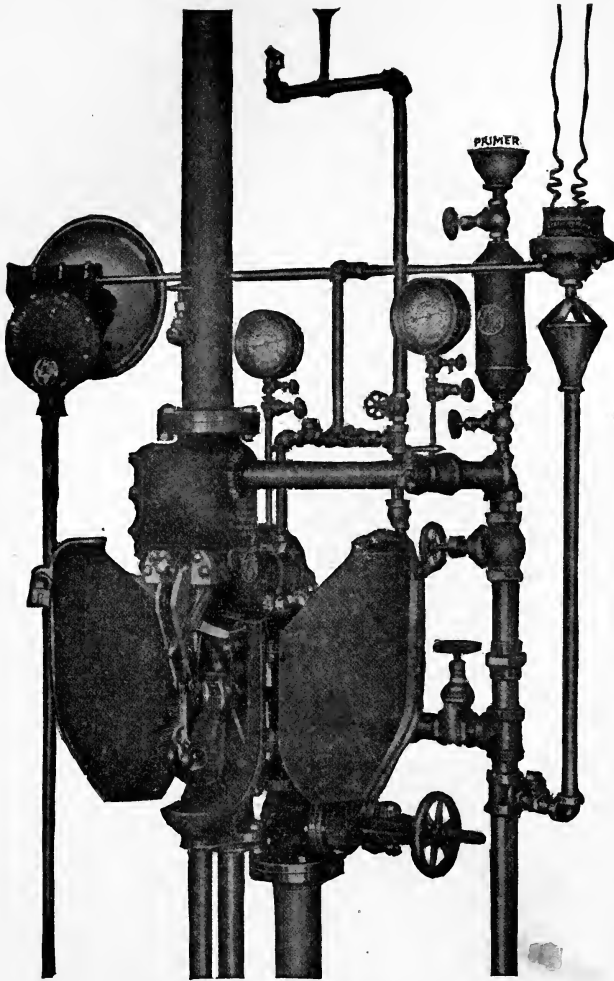

"INTERNATIONAL" DRY-PIPE VALVE
(Doors open showing valve set up.)

When the air pressure is released the vertical lever (10) is pushed up, thus releasing the weight and the whole train of levers that holds the water valve in place. When the water valve opens it swings through an angle of 45 degrees, seating tightly on the opening through which the levers pass.

The alarm attachments are similar to those used in the International alarm valve and connect with the intermediate space.

Tests and Examinations. Valve should be tested for water column by opening the test valve above the air check.

The casing around the levers can be opened to see that the parts are properly set up and not obstructed.

KANE

John Kane, Philadelphia, Pa.

1889. A globe valve with a sliding spindle controlled by a pivoted lever having a fixed weight at one end and a heavier weight resting on the opposite end to hold the valve normally closed. A lighter weighted and pivoted lever actuated by a diaphragm, subjected to the system pressure, was attached to a releasing mechanism pivoted to the end of the main lever in such a way that when the pressure was reduced the weighted end of the auxiliary lever dropped, raising the opposite end and dislodging the heavy weight from the end of the main lever. Not used to any extent.

Underwriters' Laboratories Report, 1904. Twelve features criticized.

Rating: *Unreliable.*

KERSTETER

Made by *C. W. Kersteter.*

1-1895. **Differential.** Horizontal valve. This consisted of a differential valve with air and water seat in

one plane. This was located in a casting above the main water way. The intermediate space was in the form of a groove. A spindle extended from this valve to a globe valve located in the main water way. An air pipe extended from the system above the dry valve to the space over the differential valve. When air pressure was released the differential valve was forced up carrying with it the globe valve and opening the water way.

Device and Material Committee opinion, 1904:

1. Not substantial in construction.
2. Not designed to withstand heavy pressure.
3. Subject to intermittent action after opening.
4. Invites process of setting which may leave it water columned or gaged.

Rating: *Unreliable.*

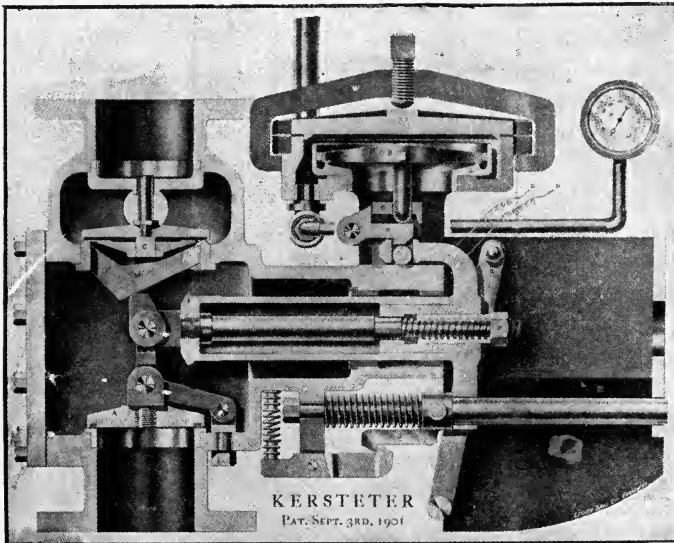

KERSTETER DRY VALVE 2.
(Section.)

KERSTETER

Made by *National Fire Extinguisher Co., Kansas City.*

2-1901. Mechanical Valve. Vertical air check and swing water check valve in main water way. Water valve closed by levers, operated by an auxiliary air valve. When the air pressure was released, the air valve was pushed up, thus releasing a rather complicated mechanism and pulling out a lever which wedged the water valve in place.

Report of Underwriters' Laboratories, 1903, criticized the valve as follows:

1. Too much variation in adjustment.
2. Opening action not positive.
3. Subject to false tripping and misadjustment as a result of wear.
4. Invites process of assembling that may leave it gagged.
5. Not designed to withstand heavy pressure.
6. Subject to clogging by mud, etc.

Rating: *Unreliable.*

LINN

Made by *A. D. Linn, Grand Rapids, Michigan.*

1894. Differential. This consisted of a vertically rising air check and water check with an intermediate space between. The air seat was offset so that it did not come directly above the water valve. The air check was connected to a hinged lever extending outside the casing with a weight on the end. A system of interior hinged levers connected the air and water valves so as to give the desired differential.

Manufacture discontinued in 1897.

Opinion of Device and Material Committee, 1904:

1. Not suited to all service conditions.
2. Unduly complicated.
3. Dependent on delicate adjustments.
4. Comparatively unsuccessful when corroded.

Rating: *Unreliable.*

MACKEY

John C. Mackey, Syracuse, N. Y.

Gate valve, normally closed and opened in case of fire by means of an auxiliary thermostat system. There was a heavy weighted arm connected to the gate valve. This was held up by a tripping lever *C*. When a ther-

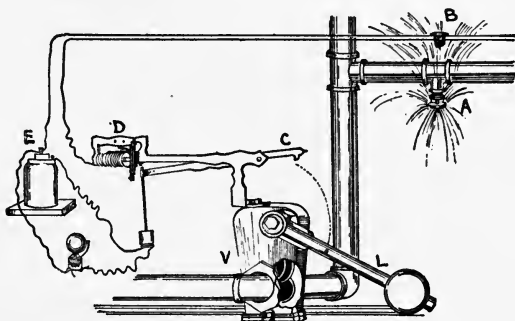

MACKEY DRY SYSTEM.

A, sprinkler. B, thermostat. C, tripping lever. D, magnet.
L, lever. V, valve.

mostat operated, the electro-magnet *D* was energized and this pulled the tripping lever and allowed the arm to fall, thus opening the valve.

Now obsolete.

Rating: *Unreliable.*

MANUFACTURERS

Manufacturers Automatic Sprinkler Co., Syracuse, N. Y.

Later "*Automatic*" Sprinkler Co. of America.

1-1892. Robert Wood Type. Mechanical valve, angle type. Swing air check, seating horizontally. Sliding water valve seating vertically. Water valve held in place by system of external levers and weights. An auxiliary air valve connecting with sprinkler system on story above, to prevent water columning, held levers in place. The auxiliary air valve was metal to metal and difficult to keep tight.

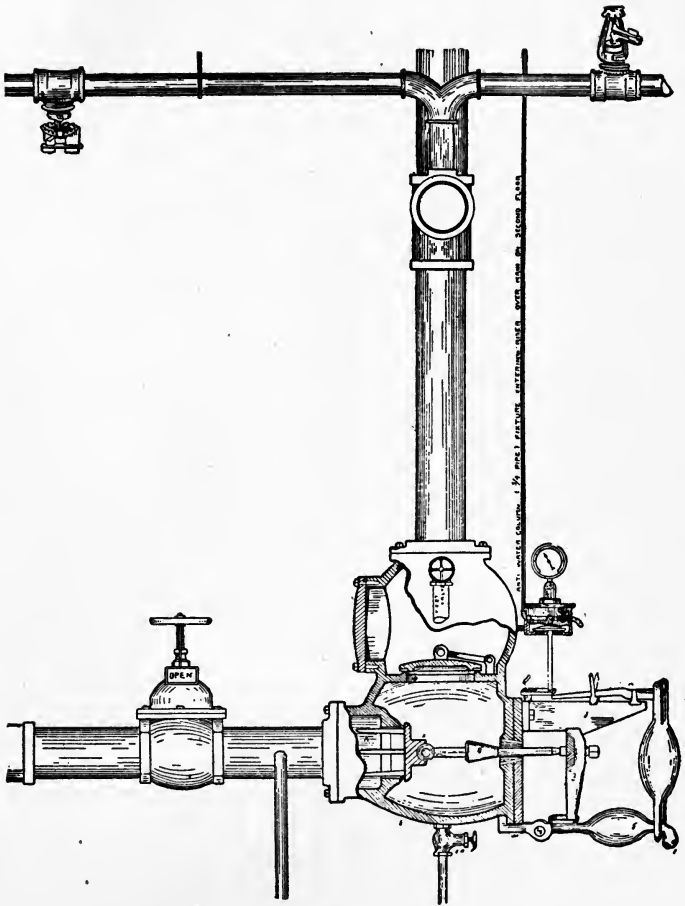

MANUFACTURERS DRY VALVE.
Robert Wood Type.
(Section.)

Criticized by Underwriters' Laboratories, 1907, as follows:

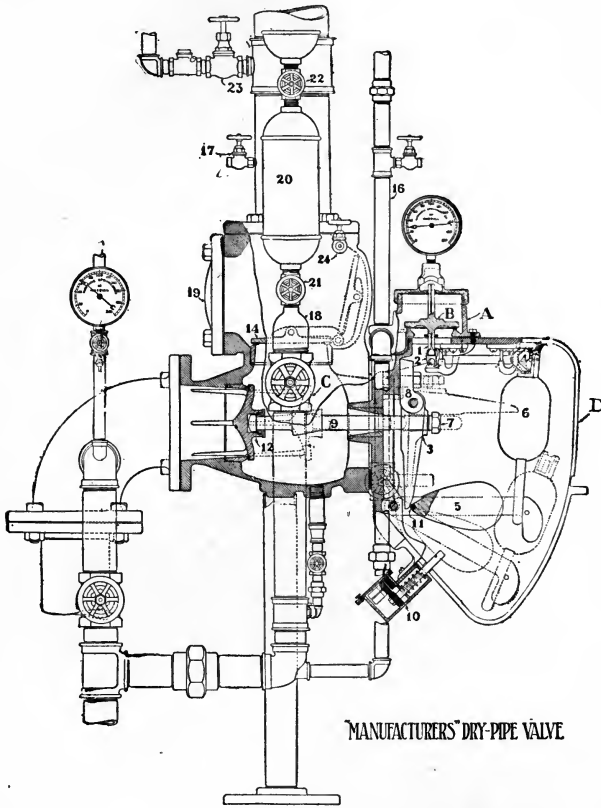

MANUFACTURERS DRY-PIPE VALVE 3.
(Section.)

1. Invites process of setting that will leave valve gaged or water columned.
2. Permits degree of variation in adjustment, causing excessive variation in trip point.
3. Is dependent on loose parts.
4. Features of design and construction.

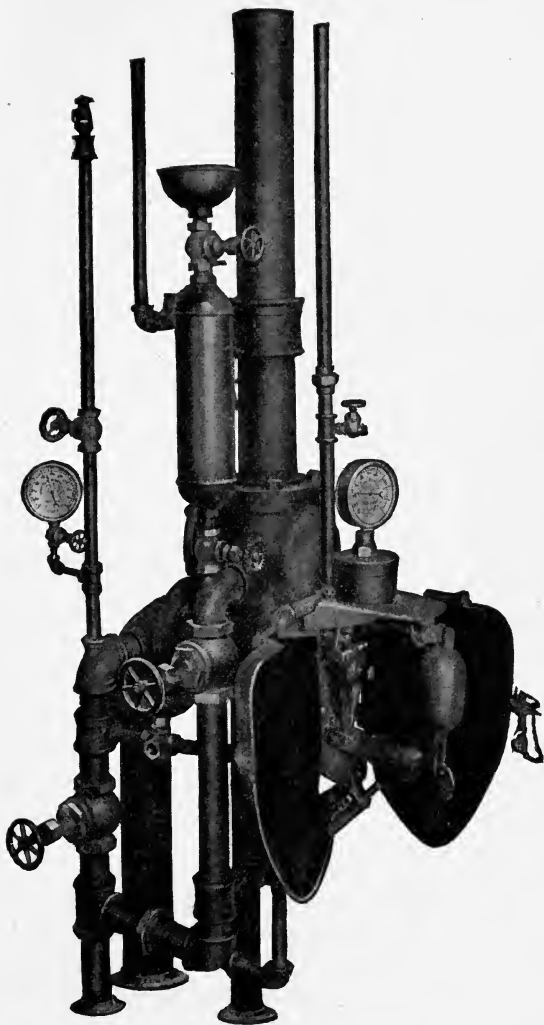

MANUFACTURERS DRY VALVE.
 No. 3 Model. General View.

Field experience unsatisfactory after a number of years service due to leaking of auxiliary air check and general use of gaskets, etc., to make it tight. A large number of valves failed on test from this cause.

Present rating: *Unreliable with old air pot.*

3-1907. New air pot of larger diameter. Weights and levers enclosed by swinging metal doors.

Description. The water valve (12) seats vertically and is held closed by horizontal stem adjusted by set screw (7).

This stem has a conical shaped enlargement (9) which, when the valve opens, tightly closes the orifice through which it passes. A train of levers and weights (3, 5, 6, 4, 2), resting finally on the under side of an auxiliary air valve *B*, holds the valve closed. The main air check is at 14 and this keeps the air pressure out of the intermediate space. An air pipe (16), connecting with the sprinkler system on the 2nd floor, holds the auxiliary valve down. When the air pressure is reduced, the train of levers is released and the valve is opened by the water pressure. The rotary gong is connected to the intermediate space. The electric circuit closer is at 10 and is operated by the weight 5 striking a small plunger.

Tests and Examinations. 1. Open the air cock above auxiliary air check to see that there is no accumulation of water that might column the valve. 2. Open casing around levers to see that they are properly set up and not obstructed. 3. In the old type care should be taken to see that the auxiliary air check has not been set up with a gasket or other foreign material and that the unenclosed levers are not obstructed.

Approved by Underwriters' Laboratories and Factory Mutual Insurance Cos.

Rating: *Standard.*

NAGLE

F. Nagle. Nagle Automatic Sprinkler Co., Chicago.

About 1889. This was a differential valve with a ratio of 1 to 15.

Description. The waste valve *B* is double seated, the intermediate space being connected to the atmosphere.

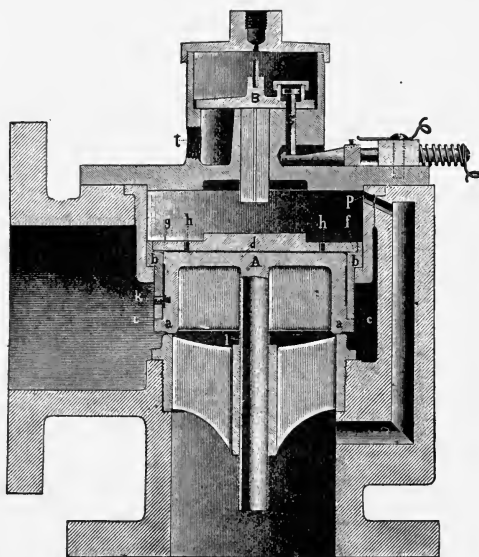

NAGLE DRY-PIPE VALVE.

(Section.)

The small outlet above this valve is connected to the sprinkler pipes normally under air pressure, thus allowing the air pressure in the system to rest on top of this valve. Water pressure from the main supply pipe reaches the lower side of the valve *B* through the by-pass *P*.

The main valve *A* is also a differential valve seating at *a* and *b*. The upper area is 60 per cent larger than the

lower area. The by-pass *P* allows water to rest above as well as below the valve, thus holding it closed on account of the differential.

When the air pressure in the system is sufficiently reduced the waste valve *B* will open. The by-pass *P* being smaller than the waste pipe *t*, the water pressure above the main valve is soon reduced and this valve opens.

There is a pin and latch connected to the waste valve *B* which operates an electric bell when the valve opens. Present rating: *Unreliable*.

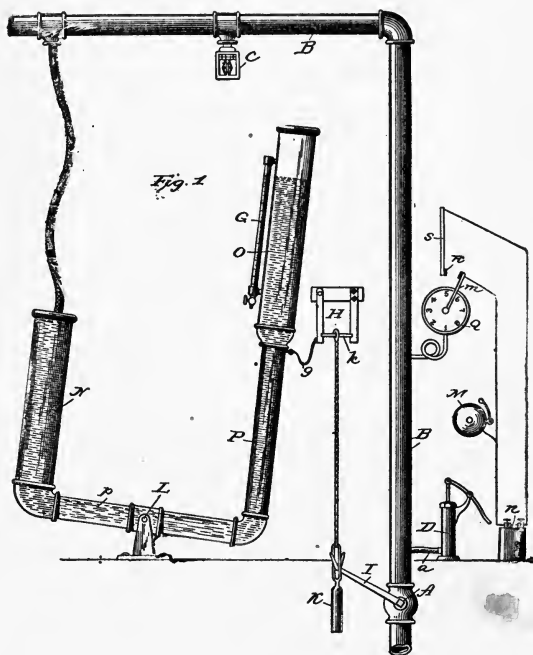

NERACHER DRY VALVE 1.

A, cock valve in main riser *B*. *N, P*, U-shaped tube. *L*, pivot. *D*, air pump. *K*, weight. *g*, cord. *k*, pin pulled out when U-tube rocked back, thus releasing weight.

NERACHER

Wm. Neracher, Cleveland, Ohio.

1-1887. Lever type. There was a cock in the main pipe operated by a lever moving through an angle of 90 degrees. When the system was set up the cock was closed and the lever engaged with a cord and weight connected with a large U-shaped tube. This tube had a short closed end and a longer open end and was pivoted at the center so that it could rock back and forth. It was filled with water up to the level of the top of the short arm. Air was pumped into the system above the cock and a flexible tube connecting the U-tube to the sprinkler system allowed the air pressure in the pipes to enter the short end of the U. This forced the water up into the long arm and caused the tube to rock in that direction. When the air pressure was released, the water level in the long arm dropped and this caused the U-tube to rock back to its normal position. This motion was transmitted to the lever by means of the cord and forcibly opened the cock.

In a later type a diaphragm was used instead of a rocking U-tube.

NERACHER

Neracher Sprinkler Co., Warren, Ohio.

2-Piston Type. Device and Material Committee opinion, 1904:

1. Has opening action traversing a pressure retaining joint.
2. Liable to intermittent action after tripping.

But few made.

NYASCO

New York Automatic Sprinkler Company, New York.

1913. This is a mechanical valve built at present only in small sizes. Made primarily for steam jets in vessels.

A horizontally seating check valve is held in place by a spindle and system of levers. A corrugated metal diaphragm is attached to the air side of the check valve

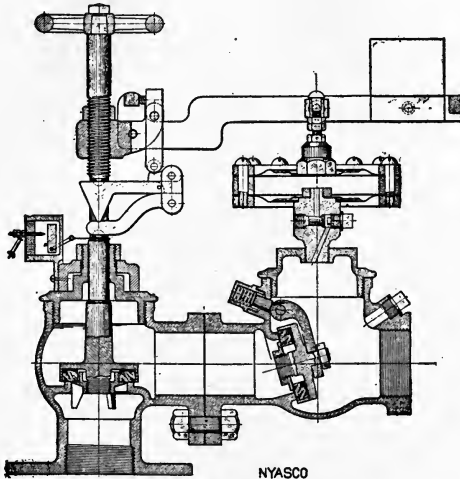

NYASCO DRY VALVE.
(Section.)

and the pressure on the diaphragm holds the tripping levers in place. When the air pressure is released the diaphragm falls and releases the levers.

Not used to any extent so far as known.

N. Y. & N. H.

Installed by the *New York and New Haven Automatic Sprinkler Co.* Office, New York. Factory, New Haven.

About 1889. This was a differential valve operated by an auxiliary thermostat system. In the cut the inlet is shown at *D* and the outlet at *K*. The inlet pipe was connected to the device between the two parts of the differential valve *A-A'*. The valve disc *A* moved

in a cylinder and was of larger area than the valve disc *A'* which seated on a knife edge. The water pressure acting on both discs held the valve closed on account of the differential.

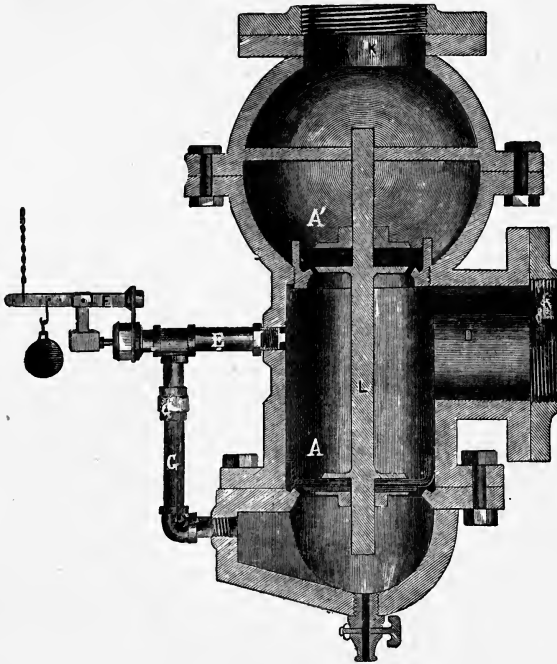

N. Y. & N. H. DRY VALVE.
(Section.)

The lever *F* was released by the thermostat system which was installed parallel to the sprinkler pipes. This opened a valve in the by-pass *E, G*, and allowed water to pass into the chamber, normally free from pressure, below the valve.

This created a pressure on the lower side of the lower valve disc which balanced the pressure on the upper

side of this disc. The pressure on the under side of the upper valve disc then raised the valve and allowed water to flow into the system. This valve was also installed with a vacuum system. In this a system of small lead piping was installed near the sprinkler piping. A hole was bored in this piping near each sprinkler head and filled with low-fusing solder. This piping terminated in a vacuum diaphragm which operated the lever *F*. Air was exhausted from the small piping, thus raising the diaphragm. When fire occurred a fusible plug melted, thus letting air into the vacuum pipes. This operated the diaphragm and tripped the lever, thus opening the dry valve.

There was an alarm gong connected to each system.

Used to a limited extent.

Present rating: *Unreliable*.

NIAGARA

Niagara Fire Extinguisher Co., Akron, Ohio.

1-1902. Kersteter Valve. Mechanical valve. Water valve a swinging check held in place by a system of levers and weights. A swing check air valve was located higher up leaving an intermediate space. Levers tripped by an auxiliary air check.

Features criticized by Underwriters' Laboratories:

1. Setting process.
2. Adjustment.
3. Action in opening.
4. Effect of muddy water.
5. Design and proportions.

But few made. Resembled No. 2 except that it had a square body.

Field experience shows uncertainty of action.

Rating: *Unreliable*.

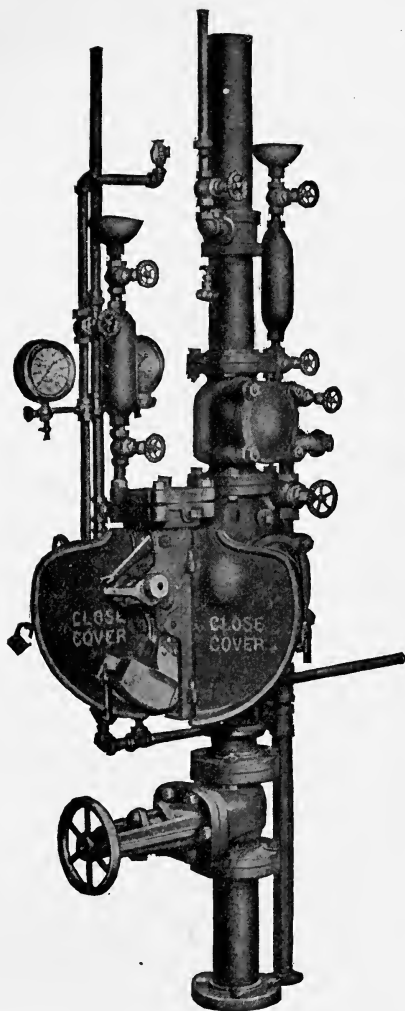

NIAGARA DRY VALVE.
 (General view, tripped.)

NIAGARA DRY VALVE

Model No. 2 (also known as *Kersteter*), 1902.

This valve was manufactured from 1902 to 1906. The body of the valve was rounding, and carried a projection to which the tripping mechanism was attached; this projection was tubular in form and cast integral with valve body. The air pot cover was held in place by a clamp; a heavy spring withdrew the plunger, which

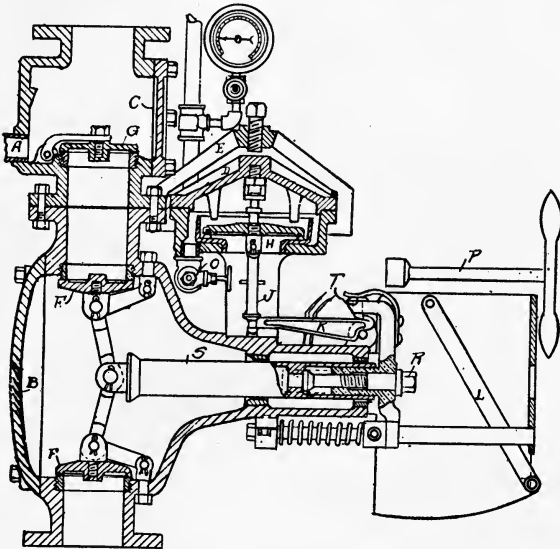

NIAGARA DRY VALVE NO. 2.
(Section.)

operated two clappers through a toggle joint, while a third clapper was located in the air check.

A large elliptical cover plate gave access to the interior of the valve, the external working parts were protected by wrought iron shields, while the stress nut was operated from the exterior.

Tested by Underwriters' Laboratories, November, 1902.

Criticism:— Setting process, adjustment, action in opening, effect of muddy water, design and proportions.

Field experience shows uncertainty of action.

Rating: *Not standard.*

Model No. 3 (Feeley Type), 1906. Manufactured from 1906 to February, 1908. The water way of this valve was offset about one-half the diameter of the riser.

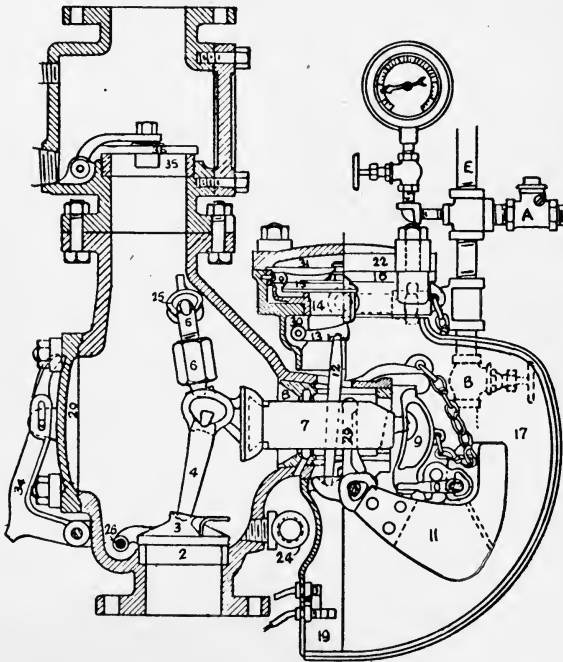

NIAGARA DRY VALVE NO. 3.
(Section.)

There was but one clapper in the main body of valve, while the stress nut was located in the interior.

A round cover plate gave access to the interior. It

was located directly opposite to the operating mechanism, and was attached to the valve by four stud bolts, and also loosely attached by a hasp or shackle.

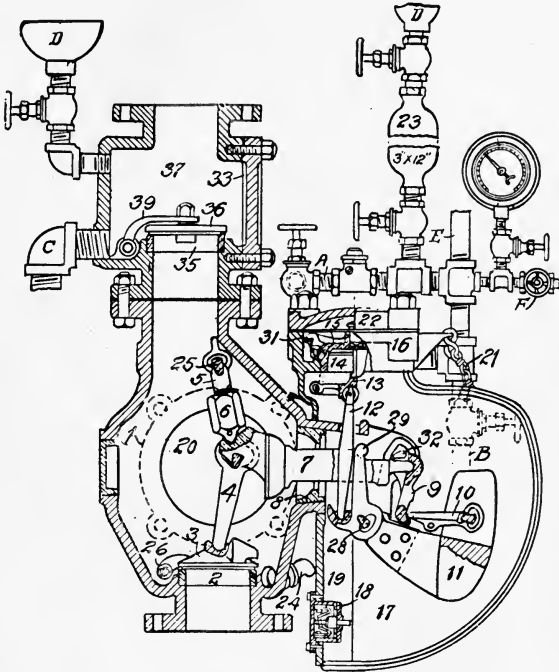

NIAGARA DRY VALVE No. 4.
(Section.)

While the mechanism was similar in appearance to the present day type, fulcrum lever No. 9 was not permanently attached, as at present, but loosely fastened with a chain, and the thrust against the air pot clapper was transmitted from the rear of weight No. 11 through a vertical strut.

The air pot cover was flat in form and attached by four stud bolts.

Rating: *Doubtful.*

Model No. 4 or Model "D," 1908. Manufactured from February, 1908, to April, 1909. This valve differs only slightly from No. 3, being a modification of same. The water way was offset as in No. 3; the hand-hold plate was on the side, but attached in same way as on No. 3. Fulcrum lever No. 9 was modified, being constructed to rotate loosely on pins and the chain was omitted.

Rating: *Doubtful.*

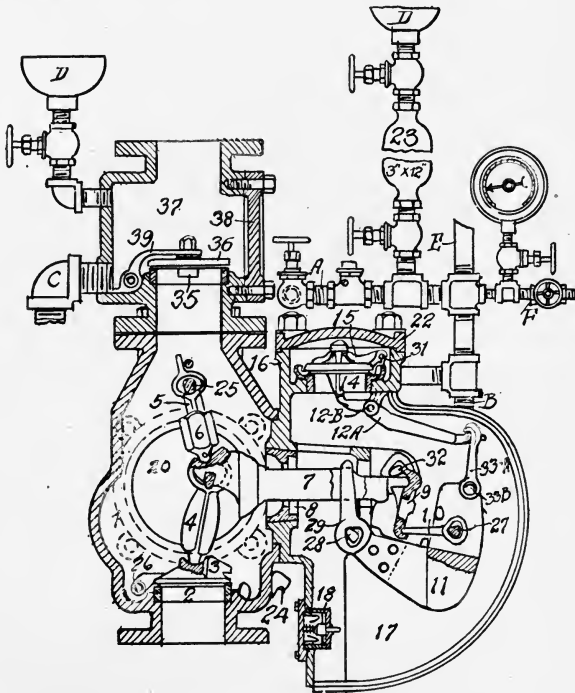

NIAGARA DRY VALVE No. 5 (Section).

Model No. 5 or Model "E," 1909. Made by *Ohio Automatic Sprinkler Co.* for "*Automatic*" Sprinkler Co. of America.

Manufactured from April, 1909, to June, 1910. The

water way in this valve was straight. The tripping mechanism was mounted on a separate casting so that it might be removed. This mechanism in former models had been supported on a cast extension on the valve body.

The method of transmitting stress from the weight to the air pot clapper was changed to the present day type, the vertical strut being omitted.

Approved by the Underwriters' Laboratories, 1909.

Withdrawn, 1915. Manufacture discontinued.

Rating: *Generally satisfactory.*

Model No. 6 or Model EE, 1910. Made by *Ohio Automatic Sprinkler Co. for "Automatic" Sprinkler Co. of America.*

Description. There is an air pot with an air check that holds in place a train of levers and weights which, when they are released, allow a horizontal plunger bearing against the toggle strut to be thrown out.

The operation of the valve is as follows: When the air pressure in the system is released by the fusing of a sprinkler, the air check (15) is pushed up and this acts on the trip lever (12-A) which releases the weight hook and the weight (11). The horizontal strut (10) then releases the fulcrum lever (9) which holds in place the plunger (7). When this plunger is released the toggle strut (4-5) collapses and the water check (2), no longer held in place, is opened by the water pressure. The water then flows up through the valve body and air check into the sprinkler system. The intermediate space is drained by an automatic ball drip and the electric alarm is given by a circuit closer (18), operated by the falling weight (11).

Tests and Examinations. Open drip valve above air check.

Open casing and examine levers.

Rating: *Not standard.*

Manufactured from Nov. 26th, 1910. This valve is identical in external appearance to model E but the

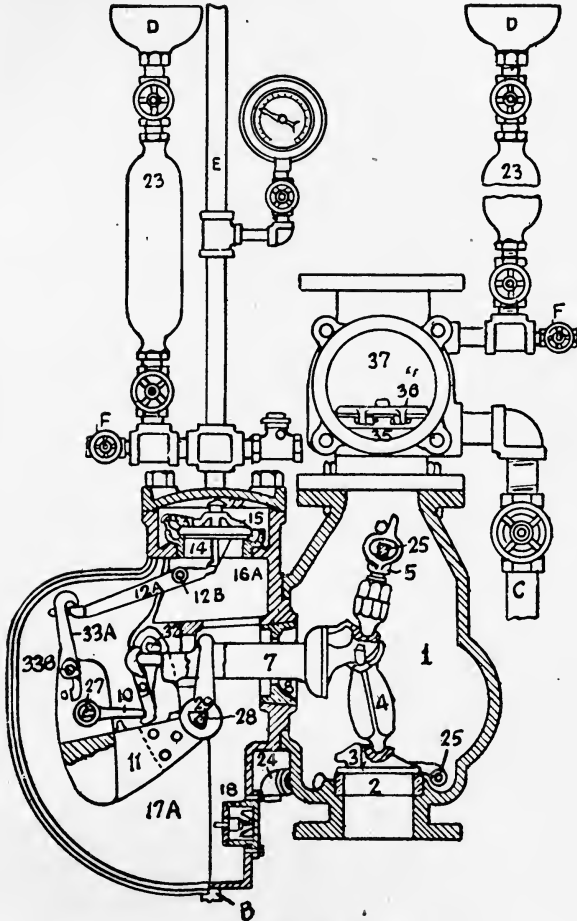

NIAGARA DRY VALVE No. 6
(Section)

bridge piece No. 5 was redesigned with an idea of lessening obstruction in the water way. The upper strut pin

No. 25 in Model E is continuous with bearings at each end in the body casting, while in Model EE the bearing consists of two short pins, one inserted on each side of the body casting, projecting only slightly into the water way. The bridge piece is "Y" shaped, with a bearing on each pin, which gives a water way about equal to size of valve.

The alarm device or circuit closer in this valve was inserted from the front, whereas previously it had been inserted from the rear of the casting, carrying tripping mechanism.

Test by Underwriters' Laboratories, May, 1912, on 4-inch sample. Heavy water clapper constructed of iron broke during test at hinge where metal had been reduced in section to permit insertion of brass bushings. Other features questioned or criticized adversely include: Low operating point, possibility of improper setting and misplacement of parts, minor features of design and construction.

Model No. 7 or Model F, 1914. Similar to 6 or Model EE except stress nut No. 6 has a projection on which the thread is cut that is threaded into the bridge piece 5. Approved by Underwriters' Laboratories, August, 1914. Not used to any extent. Superseded by 8.

Rating: *Satisfactory.*

Model No. 8 or Model G, 1915. Similar to Model EE except that a strengthening web is cast on interior of the valve above the water seat and below the hand hole cover; and a plunger to which the mechanism bearing parts are attached. Approved by Underwriters' Laboratories, 4-inch and 6-inch sizes, 1915. Also by the Factory Mutuals Insurance Companies.

Rating: *Standard.*

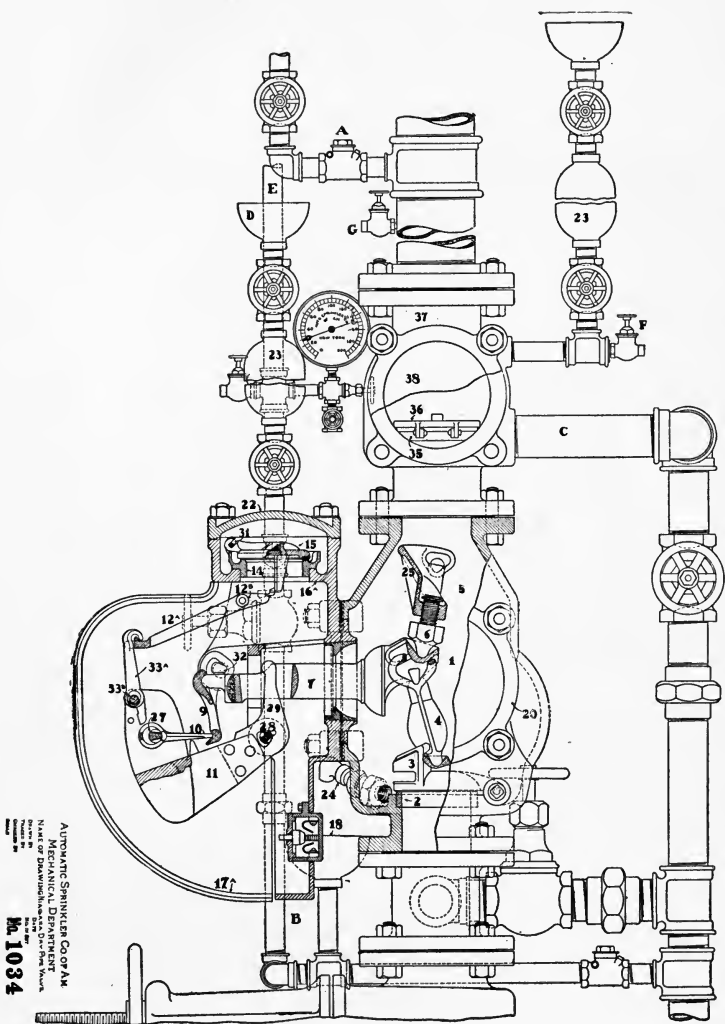

NIAGARA DRY VALVE MODEL 8 OR G.
(Section.)

AUTOMATIC SPRINKLER CO OF ALA
 MECHANICAL DEPARTMENT
 1000 1/2 AVENUE
 MOBILE, ALA.
 MADE IN ALA.
Mo. 1034

PHENIX

Made by *Phœnix Fire Extinguisher Co., Chicago, Ill.*

1. Differential. Horizontally seating water valve. Connected by a curved arm to a vertically seating air

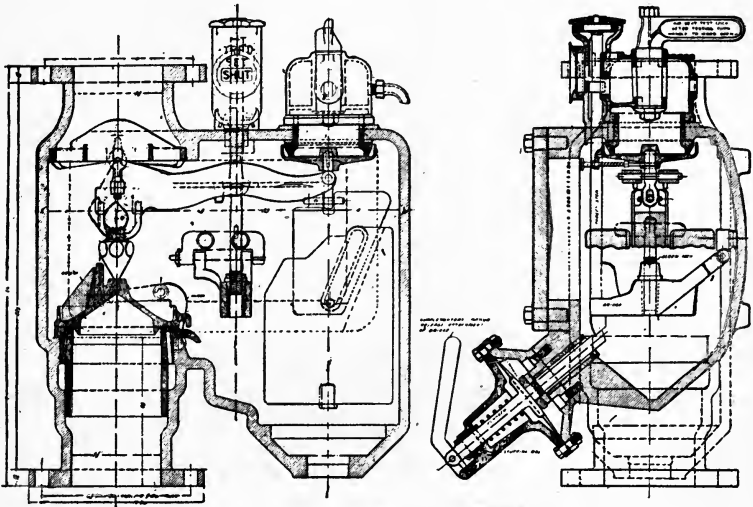

GENERAL DRAWING
3" PHENIX MECHANICAL DRY VALVE
 PHENIX FIRE EXTINGUISHER CO.
 1838-39-40 FIRST NATIONAL BANK BLDG.
 CHICAGO ILL.

PHENIX DRY VALVE.
 (Sections.)

valve of larger area. This large valve could swing through an angle of 90 degrees in an offset to the main pipe. An auxiliary air pipe connected this offset to the sprinkler piping, thus putting the air pressure onto this valve. When the air pressure was released the large valve would swing open carrying the water valve with it. There was also another air check in the main pipe above the water valve.

Underwriters' Laboratories Report, 1906, criticizes:

1. Working differential.
2. Bolted plate opening to intermediate chamber.
3. Seats liable to damage from sediment.
4. Automatic drain.

Not used so far as known.

2-1904. Mechanical valve.

5-inch size approved by Underwriters' Laboratories, 1908. Approval withdrawn, 1909. Manufacture discontinued.

Present rating: *Satisfactory*.

RICHMOND

McCrum Howell Co., Chicago.

Plans submitted to Underwriters' Laboratories. No complete device submitted.

ROCKWOOD

Geo. I. Rockwood, Worcester, Mass. · Made by *Worcester Fire Extinguisher Co.* Later *Rockwood Sprinkler Co.*

1-1906. Copy of Grinnell differential No. 12. Approved by the Underwriters' Laboratories until 1907.

A-1908. Differential valve. Large counterweighted swing check valve with air and water seat. Groove or intermediate space between air and water seat contains an automatic drip. A few of the earlier valves had a spring latch working vertically. This was replaced with a gravity hinged latch in 1909.

Rating: *Standard*.

Description. The differential valve *A* has a metal water seat and a rubber to metal air seat in the same plane. There is a groove *N* between these seats which acts as an intermediate space. There is an automatic drip *M* connected with this space as well as the alarm attachments. The valve is connected to a large arm *D*

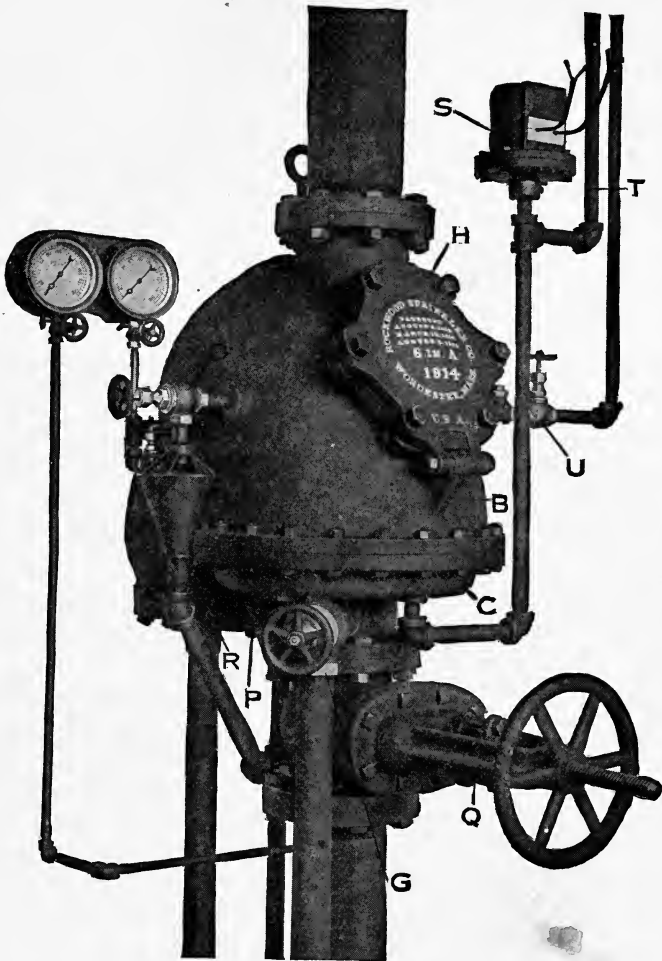

ROCKWOOD DRY VALVE A.
(General view.)

pivoted at *F* and counterweighted at *E*. There is a hinged latch *L* to prevent it from closing after it has once opened. The interior of the chamber is readily accessible through a large hinged hand-hole plate *H*.

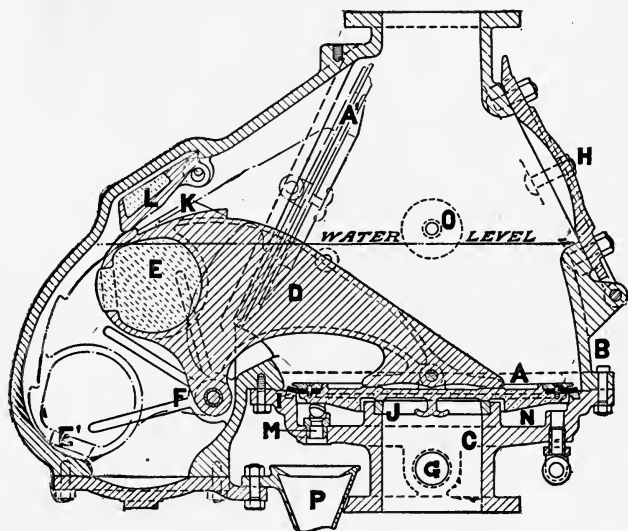

ROCKWOOD DRY VALVE A.

(Section.)

Tests and Examinations. Test for water above draw-off pipe. Test automatic drip *M* to see that it is free and not obstructed by dirt.

SHAW

Campbell B. Shaw, St. Louis, Mo.

1-1898. Mechanical valve. Water valve held closed by spindle extending through stuffing box and connected to a system of levers. These levers were tripped by the opening of a small auxiliary air valve in somewhat the same way as in the Robert Wood valve.

Rating: *Unreliable.*

2-1903. Assigned to Shaw Manufacturing Co. Mechanical valve. Water valve held closed by levers extending to outside of casing and tripped by auxiliary air valve.

Underwriters' Laboratories Report, 1902, criticizes:

1. Setting process.
2. Opening movement.
3. External operating parts.
4. Complication of part.

Rating: *Unreliable.*

STECK

E. F. Steck, Chicago. Assigned to *Fire Extinguisher Manufacturing Co.*

1-1898. Mechanical valve. Water check opening against pressure was opened by a lever counterweighted with a bucket. When the air pressure was released a small air valve was opened and this allowed some entrapped water to flow into the bucket. The weight of this water opened the main valve. Not used so far as known.

Rating: *Unreliable.*

2-1898. Similar to above except that valve was opened by a system of weighted levers held in place by small air valve.

Rating: *Unreliable.*

U. T. D. OR COX

Made by *U. T. D. Sprinkler & Supply Co., Chicago.*

Manufacture discontinued in 1900.

Opinion of Device and Material Committee, 1904:

1. Liable to be inoperative under service conditions.
2. Difficulty of cleaning and setting.
3. Dependent on skilled adjustment.
4. Subject to tripping from cessation of water pressure.

Rating: *Unreliable.*

WALWORTH

Made by *Walworth Manufacturing Co., Boston.*

1-1884. This dry valve was one of the earliest on the market and was patented by C. C. Walworth and O. B. Hall of Boston in 1884. It was installed by the Walworth Manufacturing Co. for a number of years but is now obsolete. It was not a differential valve

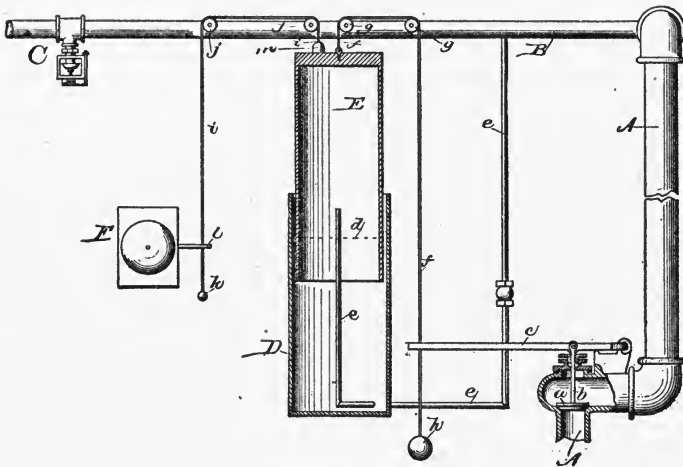

WALWORTH DRY VALVE 1.
(Section.)

A, supply pipe. *a, b*, angle valve. *e*, lever. *f*, cord. *h*, weight.
D, outer tank. *E*, inner tank. *e*, air pipe from sprinkler system.

and still did not bear much resemblance to the ordinary type of mechanical valve. The actuating device was a tank of water with an inverted tank or bell float inside on the principle of a gasometer. A cord was attached to the bell float and extended through a hole in the outer tank over a pulley to a weight. Air was pumped into the bell float, thus raising it to the stops. A pipe from the sprinkler system connected to the pipe feeding the

bell float, thus putting the same air pressure onto both the sprinkler system and the tank. The cord from the bell float engaged with the end of a long lever attached to a normally closed angle valve in the main sprinkler pipe.

When the system was set up the main valve was closed and held closed by the weighted lever. The air pressure in the system raised the bell float, thereby allowing the weighted cord to fall to its lowest position.

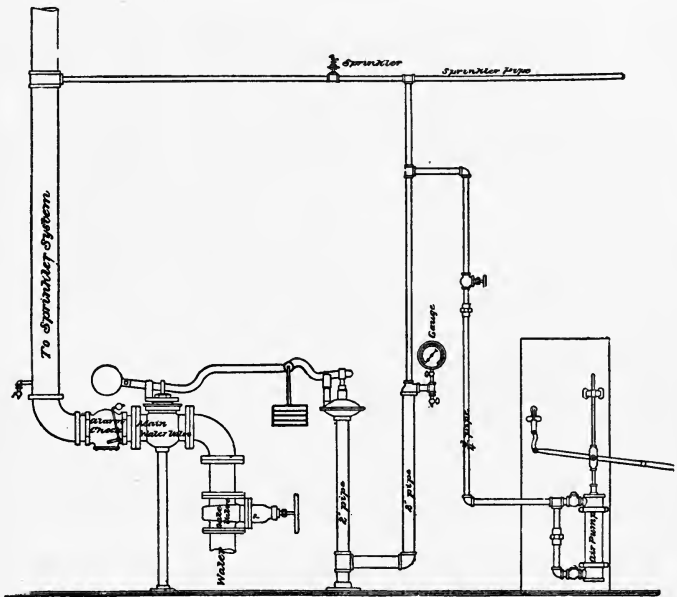

WALWORTH DRY VALVE 3.

When a sprinkler opened the air pressure was exhausted and the bell float dropped. This raised the weighted cord which, pulling on the lever, opened the valve and allowed water to enter the system.

2-1884. In another variation of this device a spindle valve was used instead of a lever valve, the cord from

the bell float being wound around a drum on the valve spindle. When the bell float dropped the cord turned the spindle and opened the valve.

Both used to some extent. Obsolete.

Present rating: *Unreliable*.

WALWORTH

3-1885. In a later type a globe valve was used to hold the water back. The stem of this valve extended through a stuffing box and was loosely fastened to a weighted lever. The long end of this lever was held in place by a tripping device operated by a diaphragm. When the lever was released by the reduction of air pressure the weighted end of the lever dropped and opened the valve. A check valve with a weighted stem kept the air pressure from the upper side of the globe valve.

Used to a limited extent. Obsolete.

Present rating: *Unreliable*.

CHAPTER IX

SPRINKLER SUPERVISORY SYSTEMS

The purpose of these systems is to give notice at a central station in case anything happens to a sprinkler system to seriously impair its effectiveness or in case there is a flowage in the pipes due to a break or to the opening of a sprinkler head. The signals are transmitted to a central station through a closed circuit system of wiring and there received on a bell and tape machine in a similar manner to thermostat signals. When a trouble signal is received a runner is sent from the central station to see that the proper remedies are applied.

This is a comparatively new form of protection, having been on the market only since 1906.

The rules of the National Board of Fire Underwriters (Signalling Systems, Class *H*) give definite requirements for many features of the wiring and central station and are as follows:

RULES OF THE NATIONAL BOARD OF FIRE UNDERWRITERS

Central Station.

(a) From the central office to the protected risk, there must be two (2) separate circuits one for the water flow alarm, and the other for the supervision features. Manuals must not be installed on the supervision circuit unless of approved non-interfering pattern.

(b) The central office must, at all times, be able to determine from the signal received, the particular feature of the sprinklered risk which is out of order and when it has been restored.

This may be accomplished by having separate transmitters for each feature of the service or distinctive signals from the same transmitter or by a combination of both methods.

Devices, Circuits, Etc.

(a) Must be so arranged that devices cannot easily be tampered with or removed without giving a signal in the central office.

(b) All circuits and electrical apparatus must comply with the requirements stated under Class A. It is, however, strongly recommended that all interior circuits be entirely run in approved conduit piping, wire to be such as is required in damp places, under Rule 3, Section *b*. Class A.

(c) All pipe connections to sprinkler system must be made in a workmanlike manner, equal in all respects to the regular standard required for sprinkler work.

(d) Not more than twenty-five (25) sets of transmitters or not exceeding one hundred (100) break wheels must be connected on a single circuit.

Tests.

Complete and satisfactory tests of all transmitters must be made by installing companies monthly and results reported to the Inspection Department having jurisdiction.

SUPERVISION DETAILS**Gate Valves.**

(a) Connection, by means of approved devices, must be made to all gate or other stop valves, under control of the assured, in feed pipes to sprinklers, including all valves on tanks, fire pump, steam and discharge connections, city main connections, pump suction, post indicator valves, and where necessary, on small valves used in installation of the service. Devices to be so attached as not to interfere with the operation of the valve nor obstruct the view of indicator or access to stuffing boxes.

(b) Attachments on all valves must give a signal between the first and second revolutions of the hand wheel, tending to move the valve from its proper position, or when valve is not controlled by hand wheel, signal must be given before the valve has moved $\frac{1}{2}$ of the stem movement from its proper position.

Two separate and distinctive automatic signals will be required for the gate valve alarm, one signal to show that a valve has been removed from its normal position, and another distinctive and different signal to show that the valve has been returned to its normal position. The latter signal shall not be given until all valves have been returned to their normal position, or at least to the point where the first or trouble signal was given.

Pressure.

(a) All tanks or their sources of pressure, including steam supply for fire pumps, also pressure on dry pipe system, must be provided with separate and independent attachments, unless otherwise specified by the Inspection Department having jurisdiction.

Pipe to which supervisory devices are connected must be provided with a plugged test gauge connection and a stop and relief valve of satisfactory pattern; the whole to be so arranged that pressure on attachment and plugged connection can be released for testing purposes.

(b) Pressure tank attachment must give a high and low pressure signal at ten (10) pounds below and thirty (30) pounds above the normal pressure.

Steam pressure attachment must give a low pressure signal at 45 pounds.

Attachment to dry pipe pressure system must give a high and low pressure signal at ten (10) pounds variation above or below normal pressure.

In special cases and for other pressure sources, specific instructions must be obtained from the Inspection Department having jurisdiction.

Two separate and distinctive automatic signals will be required for pressure alarm, one to show that the pressure has gone below or above the required amount and another distinctive and different signal to show that the normal pressure has been restored.

Water Levels.

(a) All pressure and surge tanks, gravity tanks, cisterns and reservoirs used as a supply for sprinkler systems, must be equipped with separate and independent attachments unless otherwise specified by Inspection Department having jurisdiction.

All devices used for this purpose must be designed to withstand corrosion and possible mechanical obstructions.

(b) Must give a low water signal in all supplies, except pressure tanks, when water drops 12 inches below the required level. Pressure tank device must give a signal when water drops 4 inches below or rises 4 inches above the required level.

Two separate and distinctive automatic signals will be required for water alarm, one to show that water has changed from the required level, and another to show that the proper water level has been restored.

Temperature.

(a) All gravity tanks, cisterns and reservoirs for sprinkler service in which water might freeze, must be equipped with suitable temperature indicator, located two feet below the required water level.

Note: Where tanks, cisterns or reservoirs are located in houses in which water might freeze, Inspection Department having jurisdiction may require suitable temperature indicators for such houses.

(b) The indicator must give a separate and distinctive signal when temperature falls below 40° F., or rises above 160° F., and another distinctive and different signal to show that water has been restored to the proper temperature.

Fire Pumps.

Where automatic fire pumps are used a complete supervision shall be provided in each case, for which special instructions must be obtained.

Water Flow Alarm Details.

(a) At the base of each system riser, satisfactory and positive connections must be made by an approved device for indicating the flow of water in the sprinkler system, except that due to waste surges or variable pressure.

(b) The device must indicate at the Central Station any leak or flow of water in the sprinkler system, equal to or greater than at the rate of ten (10) gallons per minute.

Trouble signal to be distinctive and different from the water flow signal.

(c) Where any private local water flow alarm system is in use the supervisory water flow alarm must be so arranged that it shall not be dependent upon the operation of or interfered with by trouble on the local private alarm circuit.

Manual Alarms.

Where a sprinklered risk is provided with either a Central Station Water Flow or a Central Station Supervision Alarm, or both, and has not an approved and properly maintained Automatic Fire Alarm System, or Watchman's Central Station Time Recording System, a Manual Fire Alarm System installed in accordance with Rules 8 and 9 must be provided.

Signals and Reports.

(a) Arrangements must, if possible, be made by the operating company, by which they shall have access to premises under super-

vision, at all hours of the day and night. Where such arrangements cannot be made and it might become necessary to force an entrance to the building, a proper guard shall be placed over the building so long as required.

Note: It will, of course, be understood that all arrangements, under the above paragraph, should be made with the owner of the property and must be subject to the approval of the Inspection Department having jurisdiction.

(b) Arrangements must be made to furnish such reports of signals that may be received and in such form as may be required by the Inspection Department having jurisdiction.

Disposition of Signals.

(a) Upon receipt of signals referring to matters of purely equipment maintenance, the operating company must immediately send a runner to investigate and, if possible, see that the trouble is remedied at once.

They shall also notify the Assured by telephone or by the quickest method available.

Written notice should be given the Assured in all cases.

(b) Upon receipt of signals showing flow of water in the system, the central office must notify the nearest Insurance Patrol and such other parties as the Inspection Department having jurisdiction may require.

They shall also dispatch a runner to the risk.

They shall also notify the Assured by telephone or the quickest method available.

In addition to which, written notice should be given to the Assured.

Note: In all cases where notification is required to parties with whom private lines of communication have not been provided, the quickest available means of communication must be used.

(c) If, at any time, a combination signal is received, which from its nature, is indicative of water flow on the premises equipped, such combination signal must be treated by the central office as a fire alarm.

All manual alarms are to be treated as fire alarms.

Note: Fire alarms received from Sprinkler Supervisory service shall be transmitted to the city fire alarm office and patrol or such other places as required by the Inspection Department having jurisdiction, and should at all times be treated as still alarms.

LIMITATIONS OF THE SYSTEMS

Supplies from tanks and automatic pumps can be efficiently supervised but where a waterworks connection is the only source of supply the supervision is not as satisfactory. The gate valves from tanks and pumps are accessible and the supervisory attachment can be readily made; but it is usually impractical to supervise the underground waterworks valves on a sprinkler connection and it is certainly not practical to supervise all the street main gate valves, the closing of which might shut off water from the risk in question. It would always be possible, therefore, that the street main or even the sprinkler connection from the main might be shut off without giving any trouble alarm. A partial safeguard can be installed in the form of an alarm gage on the sprinkler system. This is adjusted so that when the water pressure drops to a certain predetermined point, say 25 per cent below normal, an alarm will be given. With this arrangement no fire could occur without some alarm being given through the supervisory system although the sprinkler system might be practically out of commission.

If the street connection was shut off it is probable that the pressure in the sprinkler system would gradually fall until a trouble alarm was given. If, however, the system was so tight that this did not occur, then in case of fire a sprinkler head would open and the pressure would at once drop and an alarm be given. While, therefore, the water supply might not be efficiently supervised the supervisory system would still act as a fire alarm. With a sprinkler supervisory system properly installed and maintained the sprinkler system is not only supervised so that the chance of failure in time of fire is reduced to a minimum but the system itself becomes an alarm service of the most efficient

type. This service may generally be considered the full equivalent of a thermostat system or standard watchman's service when efficiently maintained.

Supervisory systems must necessarily be confined to regions where there is a considerable number of sprinklered risks near together, probably to the larger cities and their suburbs, as it would not pay to go to the expense of equipping and maintaining an expensive central station in other places.

Up to a few years ago there were two systems on the market, the American District Telegraph Co. and the Consolidated Co., but at present only the A. D. T. system is being installed.

DESCRIPTION OF DEVICES

The devices consist in general of circuit breakers attached to check valves to give water flow alarm; gate valve attachments, pressure gages, water level attachments, temperature devices and the necessary transmitters, batteries, etc. All wiring is installed in conduit so that there is no chance to short circuit the system, thus putting the alarm connections out of service. The different attachments are securely fastened in place so that they cannot be disconnected without giving an alarm and they all have case contact or telltale attachments to prevent removing the cover and tampering with the interior mechanism without giving a trouble signal.

Water Flow Apparatus. The attachment for giving the water flow signals can be fastened to an alarm valve, or to any check valve provided it is slightly weighted. It consists of an arm pivoted near the middle in a bronze diaphragm. One end of the arm extends inside of the check valve to the under side of the clapper and is normally held down by the weight of the clapper.

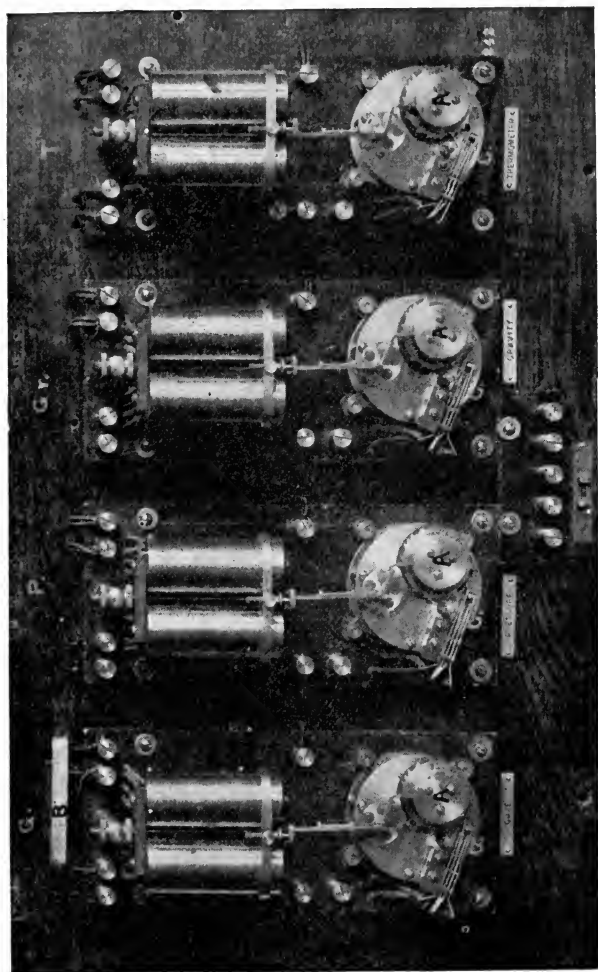

A. D. T. TRANSMITTERS. 1906 TYPE.

G, gate valve transmitter. P, pressure gage transmitter. Gr, water level transmitter. T, temperature transmitter. a, a, a, contact wheels and cams. b, case contact. c, c, c, contact springs, two sets one back of other.

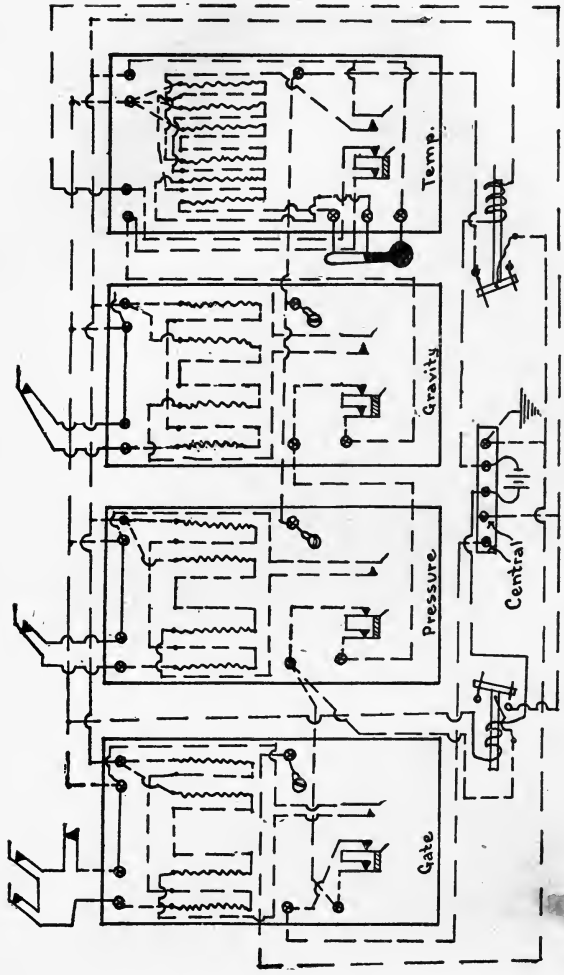

A. D. T. PLAN OF SUPERVISORY CIRCUITS.

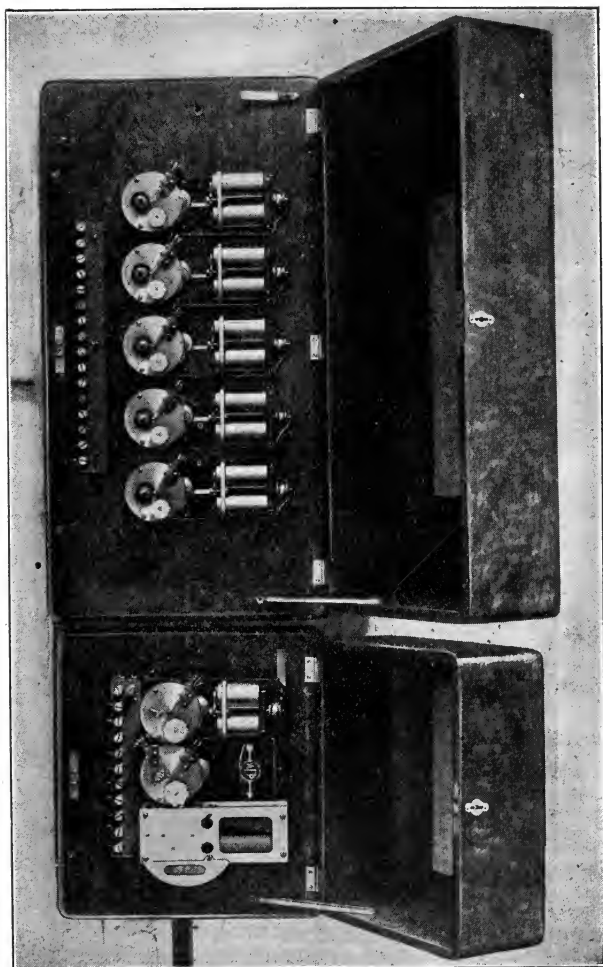

A. D. T. TRANSMITTERS. LATEST TYPE.

The other end of the arm carries an insulating ring which lifts a spring, thereby separating two platinum points. When there is a flow of water through the system the check valve rises, thus allowing one end of

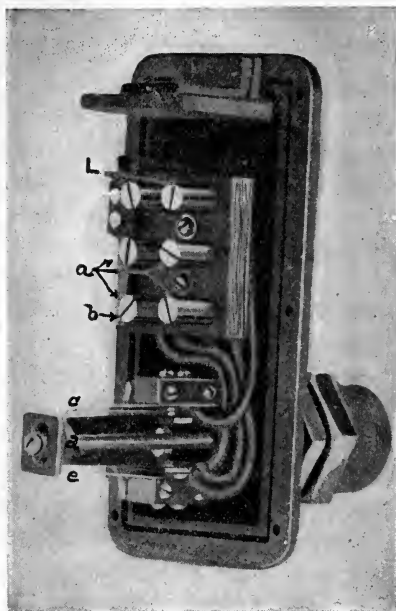

A. D. T. ALARM VALVE APPARATUS.

- a*, binding screws for circuit wires.
- L*, binding screws for local bell wires.
- b*, case contact for telltale.
- c*, platinum contact points.
- d*, insulating ring or lever arm.
- e*, platinum points for local bell.

the arm to rise and make contact between the platinum points at the other end, the motion being transmitted through the flexible diaphragm. The making of the circuit by the platinum points, starts a transmitter and

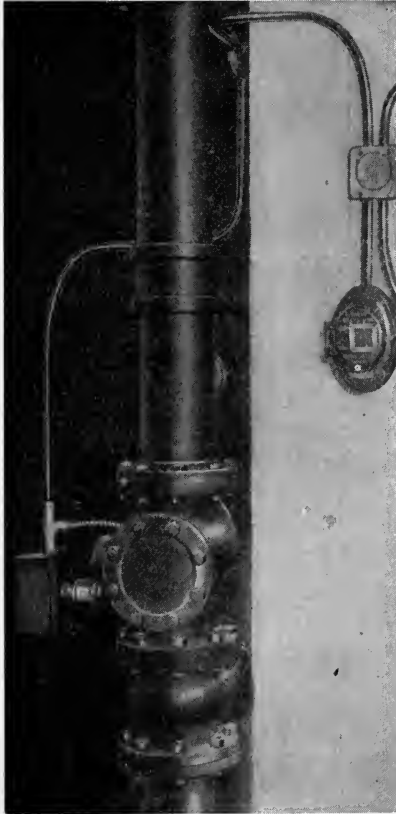

A. D. T. ALARM VALVE ATTACHMENT.

Contacts are in box at extreme left of picture. Wires run in conduit taken out at top of box. Manual alarm box at extreme right.

sends a signal to the central station. The platinum contacts are connected to the transmitter by two loops so as to insure safety and to indicate trouble. The case contact or telltale consists of a make-and-break contact in one of these loops which, when the cover is in place,

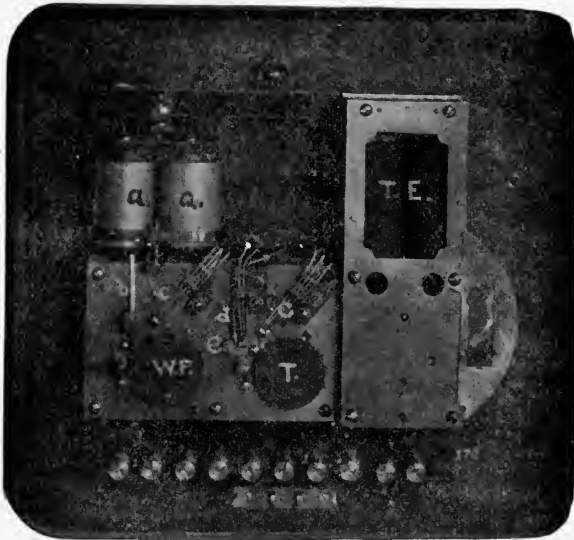

A. D. T. ALARM VALVE TRANSMITTER.

a, a, water flow signal magnets. *b*, device for causing wheel *W, F*. to make one full revolution when it starts. *c, c*, central station contact springs. *d*, springs for changing connections when wheel *T* has made one revolution. *T, E*, Time element magnet. *W, F*, water flow signal wheel. *T*, trouble signal wheel. *e*, cam for changing connections from *T, E* to *a, a*.

is held closed. When the cover is removed the circuit is broken and a trouble signal is sent to the central station.

The transmitter consists of two wheels, driven by clockwork, which are connected in series. One wheel is for trouble signals and one for water flow signals.

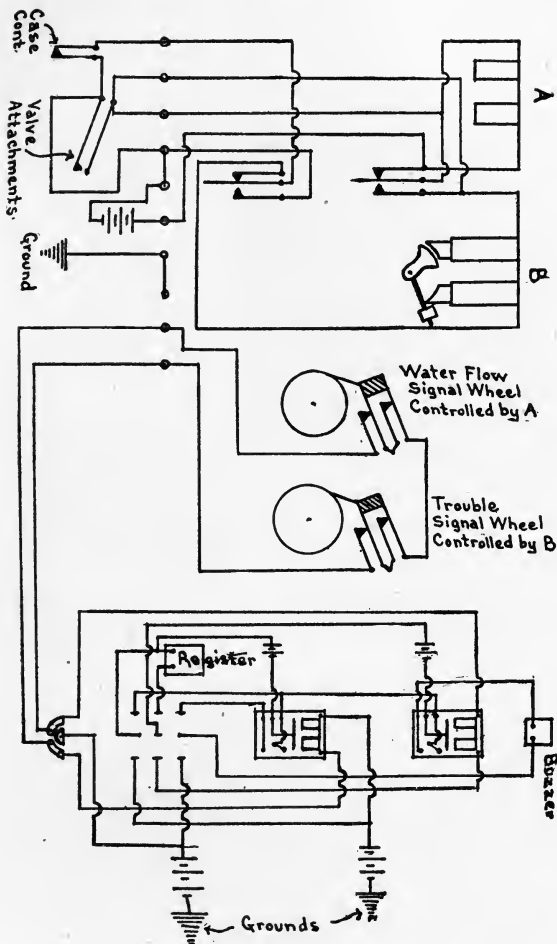

A. D. T. ALARM VALVE CIRCUITS.

The trouble signal is controlled by a time element device consisting of a large magnet energized by a local battery, and normally holding up its armature. When there is a water flow, the attachment on the check valve closes a short circuit around this magnet and allows this armature to fall. The fall of the armature is retarded by clockwork so timed that it will take longer than the duration of any ordinary hammer for the armature to complete its fall. When the short circuit is removed, the armature returns to its normal position; but if it lasts a sufficient length of time, as in case of a sprinkler head opening, the clockwork controlling the trouble wheel is released by the armature and one round of the box number is sent in short quick dashes to the central station. When this wheel completes one revolution it automatically changes the connections and closes the circuit through a second magnet which trips the clock controlling the water flow signal wheel and sends in three rounds of the box number.

If at any time the water flow should cease and the contacts in the check valve attachment open, the results would be as follows. If the short circuit was removed before the armature of the time element magnet completed its fall, the armature would return to its normal position and no signal would be transmitted. This prevents an alarm from being sent in when the water flow is of short duration such as would occur in case of water hammer. A small flowage, such as is caused by the operation of one sprinkler, would cause an intermittent action on the part of the check valve; that is the check would open for a short period and then close. In most cases the interval between the lifting and seating of the check is longer than the period of retard employed, so that while the alarm may be slightly delayed it will finally be given. In a small percentage of cases any adjustment of the retard ele-

ment that would prevent water hammer signals is likely

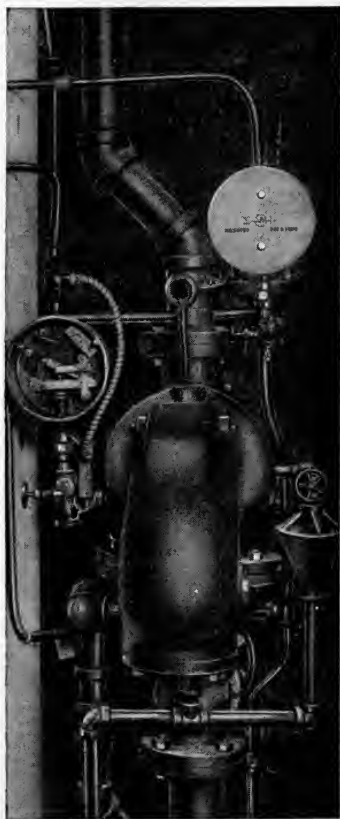

A. D. T. DRY VALVE ATTACHMENT.

High and low air pressure alarm shown in circular case at left.

Water flow switch connecting to intermediate chamber shown at right (white disc).

to cause a failure to get the water flow signal. In such cases it has been necessary to maintain an excess pressure on the sprinkler system above the check valve so as to prevent any water hammer from raising the check. This can be easily done with a small hand pump or by connection to some pump furnishing pressure for other purposes. In order to maintain the pressure properly, a pressure gage is installed on the riser arranged to give notice at the central office when any considerable drop in pressure occurs. When such signals are received, the central office takes steps to restore the pressure to its original amount.

If the contacts did not open until the trouble wheel had started, this wheel would complete one revolution and then stop. A trouble signal would be received at the Central

Station. In this case the armature of the time element would return to its normal position and the time element

would again be in service but no trouble signal would be transmitted until the box had been rewound. A second closing of the platinum points before the box had been rewound, as from water hammer, would send in a water flow signal, but not preceded, as ordinarily, by a trouble signal.

If the contacts did not open until the water flow signal wheel had started, one full round of the wheel or a complete water flow signal would be given before it stopped.

The entire system is wired on a loop, so that in case a wire is broken a trouble signal is received but the water flow signal is not crippled. The giving out of the battery causes a trouble signal to be sent in but no alarm can be transmitted until repairs have been made. The central station apparatus is arranged to indicate grounds and breaks on the outside line. A ground can be taken care of at the central station and it does not disable the circuit. A single break can be temporarily taken care of until repairs are made but two breaks in the line cut out all apparatus located between the breaks.

Gate Valve Attachment. This is a device which is clamped onto a gate valve and arranged to give a trouble alarm in case the valve should be closed or partially closed. The box is fastened to the yoke of the valve so that the rubber roller inside stands in the centre of the circle formed by the curves in two German silver springs. When in this position the platinum points on the ends of the springs are in contact and complete an electrical circuit. Another roller on the same spindle as the first, but outside of the box, fits into a groove in the valve stem. If the valve is turned a predetermined amount from the wide open position, the outside roller is moved sideways by the motion of the valve stem, thus causing the inside roller to be pushed to one side and opening the circuit. The amount of motion neces-

sary to do this can be adjusted as desired but in practice one complete revolution of the valve stem will push the springs apart and break the circuit. There is a tell-tale on this device similar to that on the water flow box which gives a trouble signal when the cover is removed. In case the whole box is removed, the spiral spring inside would move the rubber roller and force the con-

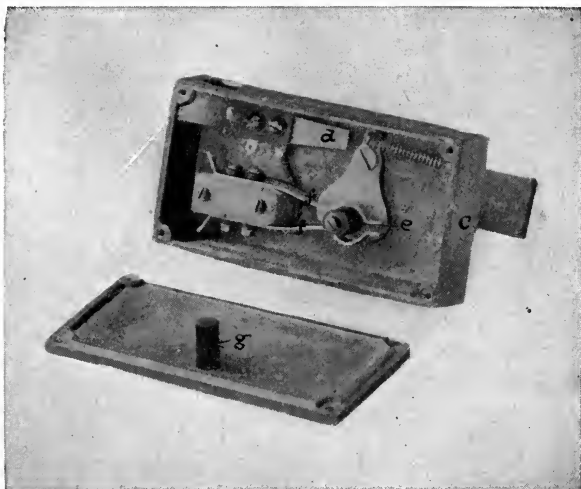

A. D. T. GATE VALVE ATTACHMENT. INTERIOR.

c, case. *d*, case contact. *e*, rubber roller. *f, f*, german silver springs. *g*, rubber post for closing case contact.

tacts apart, thus opening the circuit and giving a trouble signal.

The magnets for this device are operated by a local battery and are in multiple with those used in connection with the pressure, water level and temperature devices. There are separate transmitters for each of these devices and the central station circuit comes up to the number wheels on these. The wheels are operated by clockwork controlled by the magnets. There is

a loop around three of the magnets, normally held open by the local battery but which is closed if this battery circuit fails. The gate valve, pressure and gravity (water level) instruments are each connected in series with a double wound magnet, one circuit being normally open. This magnet normally holds up its armature but drops it when the circuit is opened by the instru-

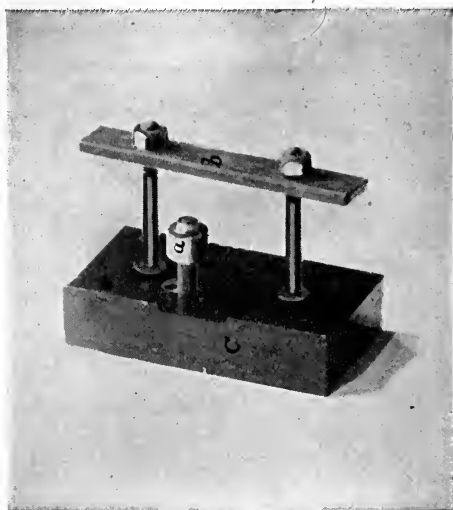

A. D. T. GATE VALVE ATTACHMENT. REAR.

a, roller that fits into slot in valve stem. *b*, clamp for fastening instrument to valve yoke. *c*, instrument case.

ment or by the removing of the cover, thus releasing the clockwork. When the armature drops, the clockwork sends in two rounds of the box number, the clock being then stopped by the lifting of the other armature on the magnet which is raised by the starting of the clock.

When the valve is again opened, the first winding is closed and the magnet is neutralized, thus dropping the

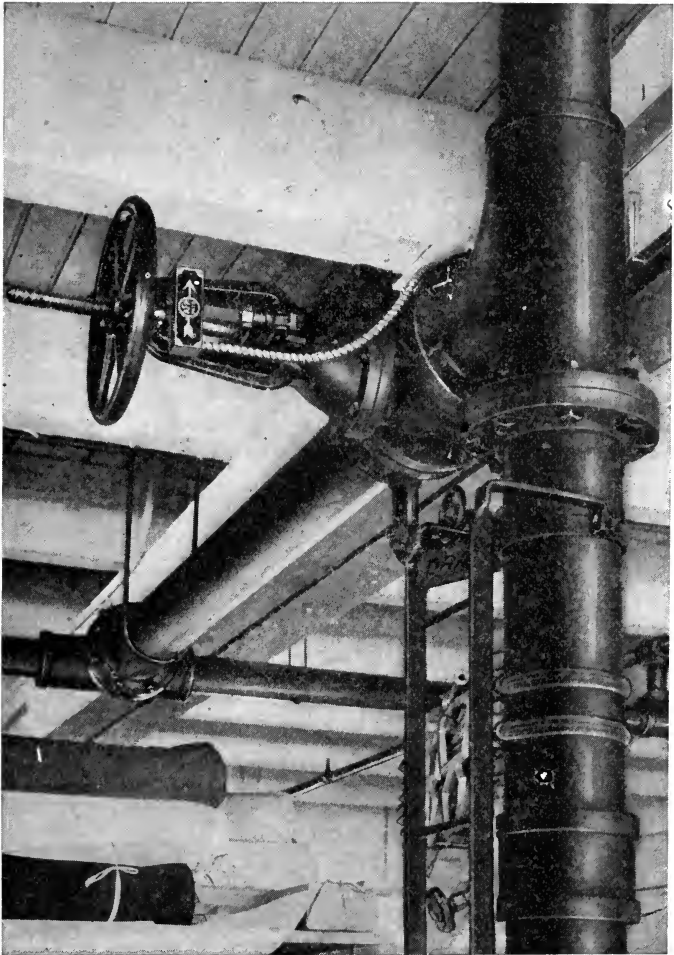

A. D. T. GATE VALVE ATTACHMENT.
Showing attachment to an O. S. & Y. floor valve.
Wiring in flexible conduit.

armature and starting the clock. When the wheel starts, the second winding is opened and the armature

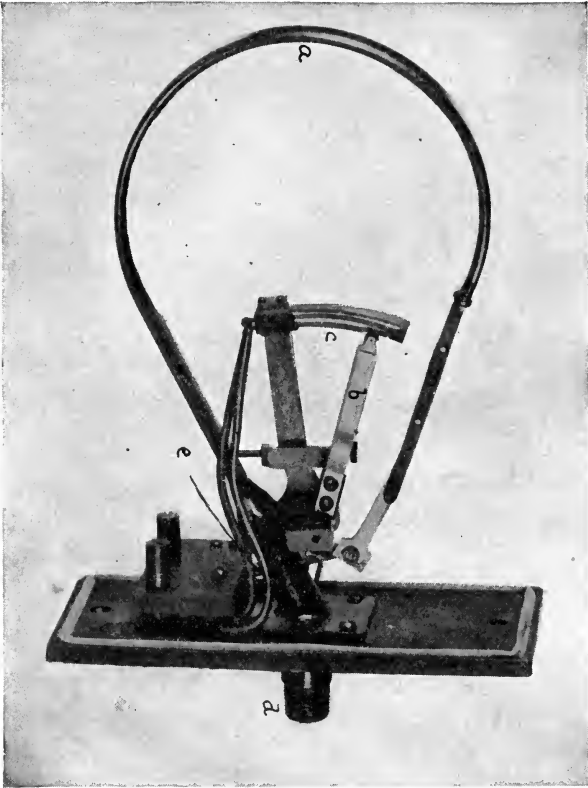

A. D. T. PRESSURE DEVICE. 1906 TYPE. No longer used.

a, bourdon tube. *b*, lever operated by bourdon tube. *c*, contact springs. *d*, pipe connections to pressure tank or dry system. *e*, case contact.

is raised by the first winding and the clock is stopped at the end of one round.

Pressure Indicator. This consists of a metal diaphragm which supports a weighted lever. When this

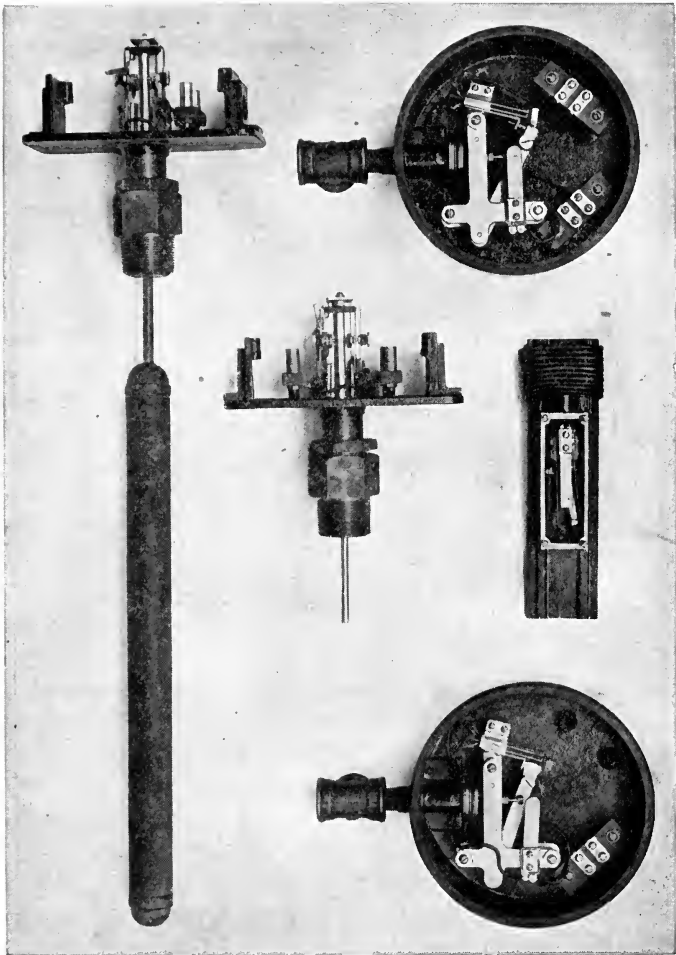

A. D. T. SUPERVISORY DEVICES.

Water level float for pressure tanks, at left. Water flow switch for alarm valves, in centre. Large O. S. & Y. valve attachment, right centre. Water flow device for dry valves, upper right. High and low air pressure device, lower right.

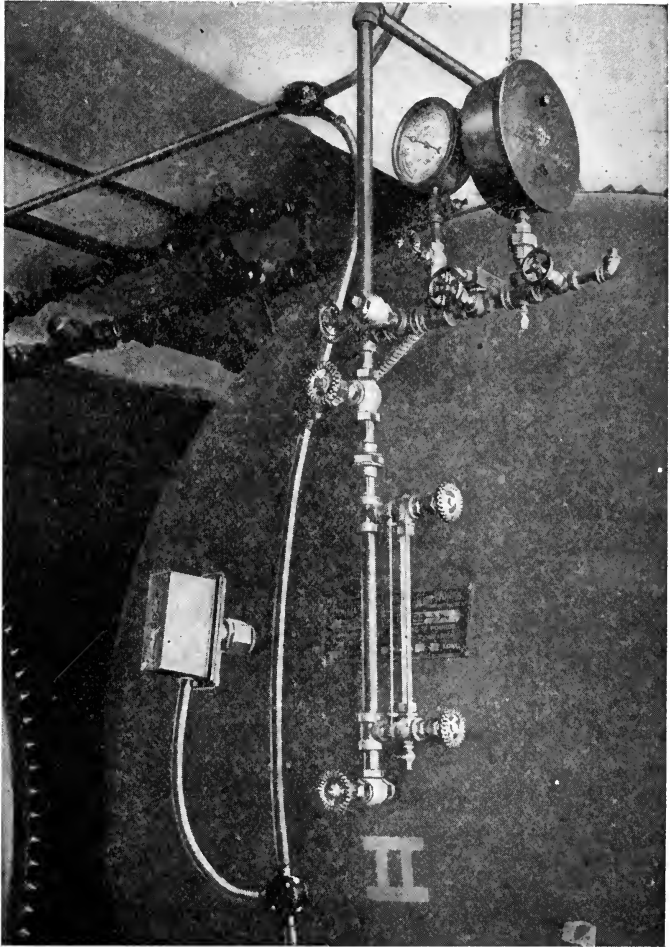

A. D. T. PRESSURE TANK ATTACHMENTS.

Water level alarm in rectangular box at left. High and low air pressure alarm in covered gage located at top of tank.

diaphragm is under pressure, the lever holds two electrical contacts together but when the pressure drops these contacts are opened. The opening pressure can be adjusted to suit any conditions. This replaces an instrument used till quite recently which contained a large bourdon spring as the acting mechanism.

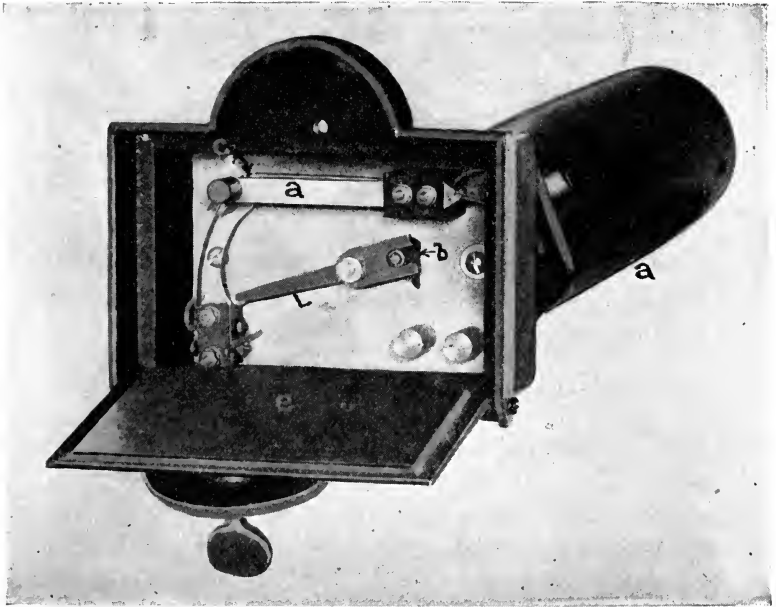

A. D. T. WATER LEVEL DEVICE. 1906 TYPE. No longer used.
a, case. *b*, lever attached to float. *c*, contact point. *d*, case contact springs. *e*, case cover. *L*, lever operated by float.

Water Level Device. This consists of a float inside of a perforated brass pipe which extends into the tank at the water level. A lever which is attached to a float and pivoted in a bronze diaphragm extends into a metal box. This lever ends in a small arm which when in its normal position holds two platinum contacts together.

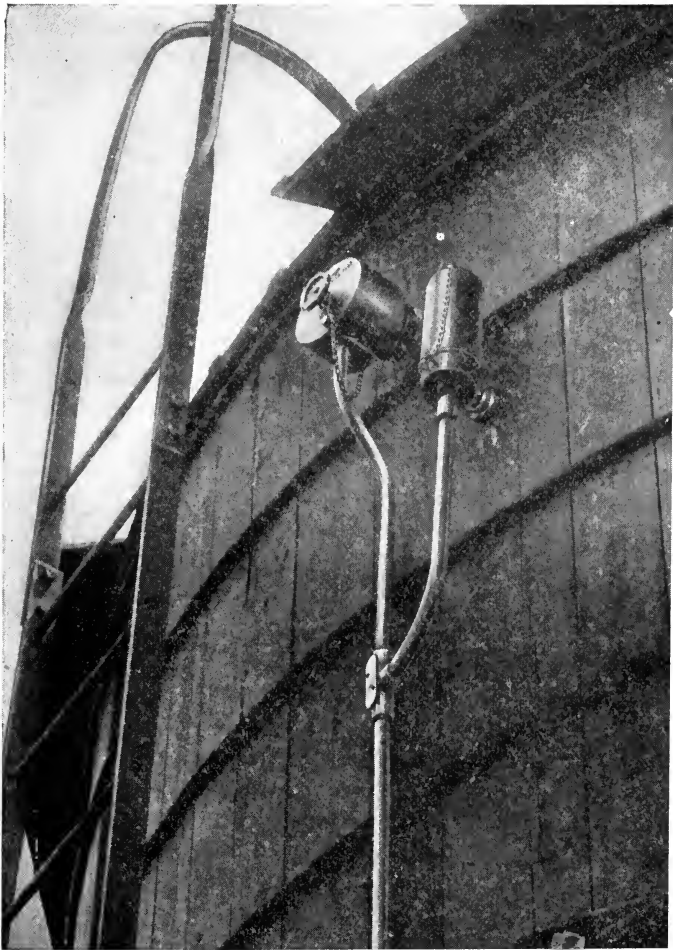

A. D. T. GRAVITY TANK ATTACHMENTS.

Water level alarm at left. Temperature alarm at right.
Wiring in conduit.

When the float falls the lever is moved and the contacts are forced apart. There is a telltale on the cover to give a trouble signal when the cover is removed.

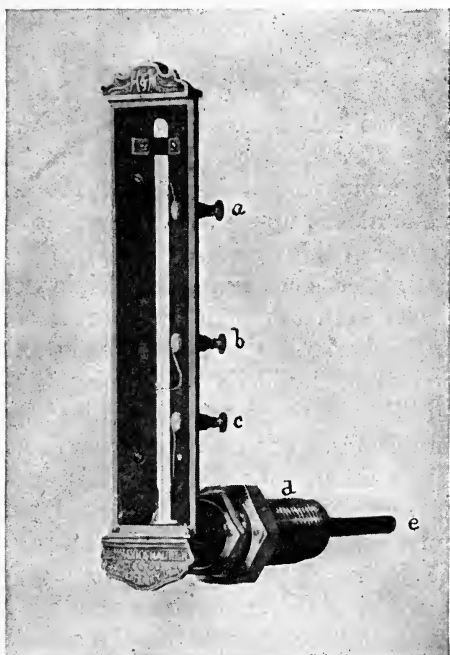

A. D. T. TEMPERATURE DEVICE.

a, high temperature contact binding post. *b*, low temperature contact binding post. *c*, constant contact binding post. *d*, screw for fastening thermometer to side of tank. *e*, thermometer bulb.

The magnets and transmitter are similar to those used in the pressure indicator.

Temperature Device. This is a mercurial thermometer, the bulb of which extends through the side of the tank into the water. Three platinum wires are fused

into the glass tube, the upper one at about 180° F. to give a signal when the temperature nears boiling point; the middle one at about 40° F. to give a signal when the temperature nears the freezing point; the lower at a point where it will always be in contact with the mercury. When the temperature is normal, that is between 40° and 180° F., the circuit is closed through the lower wire running into the base of the mercury column, and the middle wire set to indicate freezing. If the temperature drops below 40° F. the circuit is broken at the middle wire. If the temperature rises above 180° F. a short circuit is made at the upper wire. There is also a tell-tale on the cover of this device.

The thermometer is connected to a triple wound magnet. The wire from the high temperature connection runs to the third winding and is normally an open circuit. When this circuit is closed, by the mercury reaching 180° F., the magnet is neutralized by the two opposite wound coils. The armature then drops and the clockwork is started. As soon as this happens the circuit of the remaining winding is closed, the magnet again becomes operative and raises the armature, thus stopping the clockwork at the end of two rounds. When the circuit of the high temperature winding is opened again the magnet becomes neutral, the armature drops and the clockwork is started. When this happens the second winding is opened and the third winding lifts the armature and stops the clock after one round. The low temperature alarm operates in a similar manner to the other devices.

A few systems were installed in which the local battery circuit contained two relays, one of which short circuited the central station pens of the instruments and the other removed the ground connection from the same instruments in case the local battery circuit failed. This allowed the gate valve instrument to send in an

uninterrupted signal (as all four instruments start on the failure of this battery) so that "central" would be able to locate and remedy the trouble. These have not, however, been found necessary and are not now being used.

CHAPTER X

MAINTENANCE AND FIRE RECORD

MAINTENANCE

A sprinkler system, to be effective, must be maintained in proper working condition at all times. As a matter of fact these systems are very liable to be neglected, partly, no doubt, because their maintenance is not essential to the successful operation of a plant. If a sprinkler valve remains closed it does not cripple the output of a factory as might be the case if a domestic service pipe was shut off. So prone is the average owner or manager to delay or neglect repairs on his sprinkler system that the insurance companies have found it necessary to maintain a very expensive system of inspection in order that they may be reasonably sure that the equipments, for which they are allowing a very large reduction in rate, are maintained in proper condition.

These inspections bring to light a most unexpected number of defects, due mostly to carelessness or neglect. These faults are usually remedied at once and were this not so, the losses on sprinklered risks would be much larger than they are.

In 1917, in one year's inspection by the Underwriters' Bureau of New England, covering about 3650 risks, visited on an average of twice a year, the following defects were found:

Sprinkler gate valves closed	206
Sprinkler gate valves partially closed	23
Tanks or reservoirs over one-third empty	63
Tanks or reservoirs frozen	16

Steam pumps out of service	31
Rotary pumps out of service	48
Dry-pipe systems shut off	42
Sprinklers frozen	51
Alarm valve rotary gongs out of order	239
Alarm valve electric gongs out of order	349

Sprinkler systems, like other fire appliances, are emergency devices and are seldom needed but when the occasion arises they are the most important devices in the plant.

Inspection Methods in Use. Attempts have been made to solve the problem of inspecting fire appliances in three ways.

1. *Inspection by the Company that Installed the Device.* In Russia and in some other countries sprinkler systems are regularly inspected by the installing companies and in our own country certain devices like sprinkler supervisory and thermostat equipments are often under similar inspection. The advantage of this system is that the inspectors are experts in their line and take pride in seeing that the devices are kept in good order. The disadvantages are: that it requires a different set of inspectors for each type of device; that it tends to take the responsibility from the owners and to prevent them from becoming familiar with their own devices; that inspections cannot usually be frequent enough for the best results.

2. *Inspection by Bureaus Supported by the Insurance Companies.* By this method one man can make the inspection of all the devices in the plant as well as make suggestions for lessening the fire hazard and keep the insurance companies informed as to conditions. He is unprejudiced and primarily looks after the interests of his employers who desire first of all the prevention of serious fires. The principal defect in this method, which is common to the first method, is that inspections cannot be made frequently enough.

At best such inspections are not made oftener than three or possibly four times a year and a device might remain out of order three or four months if the Assured were to rely entirely upon supervision by the insurance companies.

3. *Inspection by the Assured.* The great advantage of this method is that it can be done as often as it seems necessary and that there is constantly some one on hand who is familiar with the work. The disadvantages are that the inspector is apt to be prejudiced and not to report matters which it is his interest to conceal. He is also apt to do the work in a perfunctory manner and not to be thorough. There is little incentive to do careful and accurate work.

All three systems have their defects, but as no one defect is common to all, it follows that a combination of these should give satisfactory results. In other words, weekly inspection by the Assured, inspection every three or four months by the insurance interests and regular inspections of certain complicated devices, like sprinkler supervisory and thermostat systems, by the installing companies should result in proper maintenance of fire appliances.

Care of Valves. The closed gate valve is the most important and frequent defect found at inspections. Valves are usually closed for repairs by some employee who forgets to open them and who neglects to notify the manager that they have been closed. The mill can be operated even if all the sprinkler valves are closed and there is nothing to call the attention of the management to the fact except inspection.

The sealing or strapping open of supply valves is one of the best safeguards against this trouble. It tends to prevent malicious or thoughtless closing of valves and also tends to impress upon the employees the importance of using great care in handling these devices.

There are two distinct methods of handling this matter. First by putting the full responsibility upon the Assured and requesting that they keep the valves strapped open. Second by having the valves sealed by the insurance inspectors. The first method is the most common and the results are usually satisfactory in well-managed plants where there are good men in charge of the fire appliances. The second method has long been used in cities where there are local inspection bureaus and where inspectors can be sent at short notice to reseal valves. In locations where the inspection department has to cover a large territory it has not been considered quite as desirable for it may be some time after the notification of a broken seal is received, before an inspector can be sent. Meanwhile the Assured are more apt to neglect the apparatus, putting too much responsibility upon the inspection bureau. When this method is used it is of course quite necessary to have some easy method by which the Bureau may be notified whenever a seal is broken. Self-addressed postal cards supplied for the purpose are sometimes used but even with these, the matter is very apt to be forgotten.

A method of easy notification of such trouble, and one that tends to prevent the shifting of too much responsibility onto the inspection bureau was inaugurated by the writer recently and has been giving excellent results. A special non-stripping wire with the ends sealed with a small lead seal is used for this purpose and a tag, giving directions as to what to do in case the valve is closed, is slipped on to the wire.

This reads on one side as follows:

Name of risk..... *File No.*.....

SPRINKLER VALVE

Controlling..... *Valve No.*.....

Sealed (date)..... *by*.....

In case seal has to be broken please fill in the following data, **TEAR OFF THIS TAG WHERE COUPONED** and send this tag at once to address on reverse side. Open the valve again as soon as possible, strapping it with leather strap, ends riveted or padlocked.

This seal IN NO WAY RELIEVES THE MANAGEMENT OF THIS PLANT OF FULL RESPONSIBILITY FOR PROPER CARE OF VALVES and other fire appliances.

Seal broken (date).....

Cause.....

Is Valve still shut..... *Signed*.....

The inspector fills in the data on the first 3 lines when the seal is affixed. On the other side of the tag is printed the name and the address of the Bureau with a rectangle for a stamp.

When a valve is closed, this tag is torn off, the necessary data filled in, a stamp affixed and the tag mailed.

By this method there is much less chance for the matter of notification being forgotten and much valuable information is received by the Inspection Bureau. If conditions warrant, an inspector can be sent at once to the plant. If not, the valve can be resealed at the first convenient opportunity.

Nothing that cannot be readily broken should be used in sealing valves. Heavy chain and padlock is undesirable because in case of emergency when the key is

not at hand the valve cannot be closed without considerable delay. A light leather strap with ends padlocked or riveted is preferable.

If seals are used, a wire with ends fastened by a lead seal is a desirable arrangement. A non-stripping wire consisting of a small wire wound spirally around a larger wire is now made for this purpose. Self-locking tin seals about $\frac{1}{4}$ inch wide are convenient but are not recommended for the reason that the edges are rough and sharp and apt to cause a bad cut if an attempt is made to break the seal by pulling it with the hand. Several bad cases of blood poisoning have resulted from the use of these seals. Such seals can, however, be used in conjunction with a leather strap or a chain to fasten the two ends together.

The Associated Factory Mutual Insurance Companies have recently inaugurated a system of tagging valves in which the full responsibility is placed on the Assured. They use a large red tag containing certain data to be filled out which is printed in duplicate on the upper and lower half. It is planned to use this only when a valve is closed. The data to be filled out includes the valve number, date and time when closed, by whom closed, reason for closing, time opened, etc. When a valve is closed the upper part of the tag, properly filled out, is tied onto the valve. The lower tab is torn off at a perforated line and after being properly filled out is placed on a peg in the office of the master mechanic. There is a large board for this purpose containing pegs properly numbered representing each valve in the plant. The tab is placed on the proper peg and remains in this conspicuous position as long as the valve is closed. When the valve is opened both the tag and tab are removed.

This plan should work well in large plants where there is a responsible master mechanic.

Drip Valve Tests. Careful tests should be made of water supplies at each inspection to see that they are not deficient in volume or pressure. In the case of waterworks, this can often be determined by careful flowing tests on hydrants when these are available. In other cases a careful drip valve test should be made. Each sprinkler system should have a 2-inch drip pipe and gage located on the riser just above the main gate valve. By opening this drip valve wide for a few minutes the drop in pressure due to this flowage can be ascertained. This drop will vary a good deal with the local conditions, such as length of drip pipe, the number of angles it contains, the point of discharge (whether into a sewer pipe or not), and location of gage. If the gage is located on the drip pipe it will show an apparent excessive drop owing to the suction action of the water flowing past. The gage should be on the main riser about a foot above the drip pipe.

Unless the conditions are abnormal, the drop in pressure should not be much over 10 per cent and if it is over 25 per cent it is safe to assume that either the testing conditions are not normal, the supply is weak or there is some obstruction in the pipes. The latter may be due to a partially closed valve, ice, stones or other foreign matter which may get into the pipes.

While such tests may not be absolutely accurate still they give a good method of judging in a general way the value of the water supply and are of special importance in making comparative tests. If a test is made when the system is first installed and the drop in pressure noted, this will form a basis for future comparisons. If at any time the drop is found to greatly exceed the previous figure, it is safe to conclude that the pipes have become obstructed by a partially closed valve, by ice or by some other foreign matter. Such tests are

of especial value during very cold snaps when underground pipes are liable to freeze.

A 2-inch pipe has about the same capacity as 16 sprinkler heads and this test will give a rough idea of the number of sprinklers that the water supply is capable of feeding.

Tanks and Pumps. Tanks should be examined to see that they are full and the contents not frozen. A careful watch should be kept upon the tank and its supports to see that they are not deteriorating. The hoops on a wooden tank are usually the first part to give way especially if they be flat hoops, which usually corrode on the inside while the outside is often apparently sound.

Pumps should be started at each inspection and tested to full capacity at least once a year.

Dry Valves and Alarm Valves. Dry systems should be examined to see that the air pressure is between the proper limits and that there is no water above the level of the draw-off pipe. Dry valves should be examined to see that they are not obstructed and the regular tests for each particular type should be made.

Alarm connections on both dry valves and alarm valves should be tested; the electrical connection at each inspection, and the rotary gong at least twice a year.

Sprinkler Systems. Inspectors should note the number of extra sprinklers on hand. The rules require at least six and in large plants there should be more. Care should be taken to see that the protection has not been impaired by the installation of partitions or shelves that would obstruct the distribution from the sprinklers. If a partition is not installed midway between the sprinkler heads on each side, it is an obstruction to the distribution. The remedy is to move the partition or to install additional heads, in order to properly cover the area. As a makeshift remedy, large holes are sometimes cut in the partition but this can never give good

protection. It is, however, sometimes possible to cut down a partition several feet and thus get satisfactory results.

New additions should be equipped with sprinklers before they are put in use. New shelves and platforms should have sprinklers installed below them or if not too wide, they may be considered satisfactory if set away 3 inches from walls.

All stock storage should be kept at least two feet below the ceiling as called for in the rules.

Sprinkler heads and piping that are exposed to cold should be carefully watched so as to prevent freezing. This applies especially to heads in monitors, entryways, near large doors, in attics and in basements. Sometimes the wrapping of the pipe in insulating felt is sufficient but generally the only safe remedy is more heat.

In some locations, such as sugar refineries, flour mills, etc., the sprinklers become coated with dust and powder. A careful inspection should be made to determine whether or not this affects the proper operation of the head. In many cases dusting the head is all that is necessary but in other cases a thorough cleaning or replacing of the head may be required.

Sprinklers are often carelessly painted or white-washed when a room is being redecorated and any heads so treated should be replaced or thoroughly cleaned. In all plants where acids or alkalies are used and also in very wet locations, the sprinklers are subject to corrosion. An expert inspector can usually tell by a careful examination whether a head is dangerously corroded or not. If any doubt exists, about one dozen should be removed for test. This can be done by sending them to the Underwriters' Laboratories, Inc., or to one of the Bureaus owning a testing oven. If found defective they should be replaced at once. If the solder

is found to be brittle on scraping it with the point of a knife it shows that it has crystallized and is in a dangerous condition.

The older makes of sprinklers should be carefully watched for the effects of age. While some types will last much longer than others, it is desirable to test

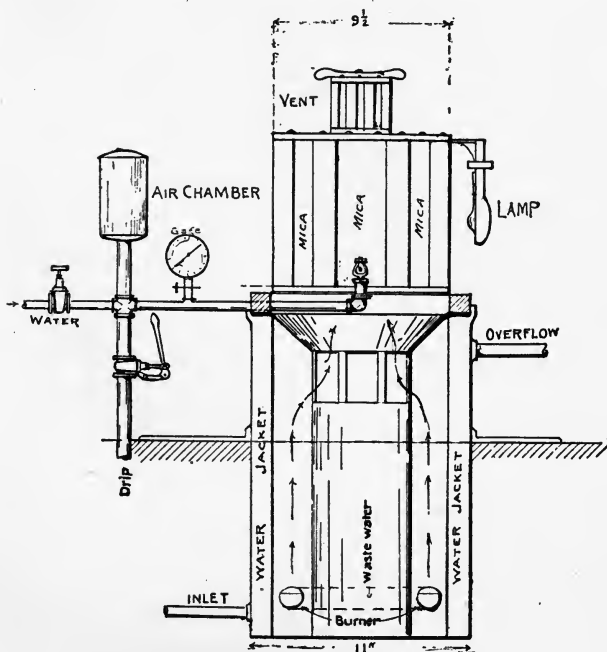

SPRINKLER TESTING OVEN.

As used by the Underwriters' Bureau of New England.

samples of any heads that have been in use over twenty years, at intervals of two years, to see that they have not deteriorated to a point where they can no longer be considered reliable.

Tests of Sprinkler Heads. Several field tests for automatic sprinklers have been suggested but it is not

believed that these are usually accurate enough for reliable results. The general practice today is to test heads in hot air ovens where the conditions will resemble an actual fire as nearly as possible. The head is screwed into a fitting connected to a water supply which is capable of giving a large range of pressures. It is not considered advisable to test a head under air pressure as it is not as severe a test as one with water in the pipes and any head on a dry system is liable to be under water pressure when it operates. It is desirable to start the test under a light pressure, say 5 pounds, as this is a more severe test than if the pressure were higher. A head in almost any equipment may be called upon to operate under such a pressure, in case a large number of heads have already opened so that the normal pressure has been greatly reduced.

A double walled or jacketed oven, about 10 inches diameter and 30 inches high, surrounds the head. A gas burner is placed in the bottom, the flame being protected from water that may issue from the sprinklers by a metal hood. The oven is adjusted to a certain rate of heating and this rate should be accurately maintained in all tests. The Underwriters' Laboratories use the following:

Time.	Temperature.
Minutes	Degrees
0	100
1	150
2	190
3	218
4	235
5	250
Above this about 10° per minute.	

The Underwriters' Bureau of New England formerly used the following rate:

Time.	Temperature.
Minutes	Degrees
0	100
1	275
2	350
3	390
4	415
5	430
6	440

Under these conditions a new clean head should operate in $1\frac{1}{2}$ to $2\frac{1}{2}$ minutes. High test heads should operate as follows: 212 degrees — 2.5 to 3.5 minutes; 286 degrees — 4 to 6 minutes. If the head does not operate in 4 to 5 minutes the pressure is raised to 100 pounds or until it operates. When one test has been completed the oven is quickly cooled by circulating cold water in the surrounding jacket.

Self Inspection. In all well-managed plants it is now generally recognized that self inspection of fire appliances is necessary if these expensive and complicated devices are to be kept in the highest state of efficiency. The engineer or master mechanic is usually given charge of the system and either he or one of his subordinates makes regular inspections. For the best results the inspection should be made by some disinterested employee who reports in writing to the man having charge, in whom full responsibility is vested. In some of the larger plants it has been found that it takes practically all of one man's time to do this work thoroughly and in several plants which have come under the writer's notice a man, often called a fire marshall, is hired solely for this purpose.

No such system of inspection can be considered en-

tirely reliable unless a report blank is used. On this is noted the matters to be investigated and against each item the inspector notes the conditions as found. The report, duly signed, is submitted to the engineer in charge who takes note of any repairs that may be needed and then forwards it to the superintendent or manager. After he has looked it over the report should be filed away for future reference.

The Fire Underwriters' Uniformity Association has adopted a blank for this purpose which will be found in the appendix.

The principal items relating to the sprinkler equipment are as follows:

1. Inside valves. Location and condition of each.
2. Outside valves. Location and condition of each.
3. Dry systems. Location and air pressure. Dry valve closet properly heated. List of systems where water has entered and reason therefor. Hand hole plugs in place. Flanged dummy in place.
4. Alarm valves. Condition of controlling valve. Condition of alarm connections.
5. Automatic sprinklers. Any corroded, bent, whitewashed, painted, dirty or obstructed. Any additions needing sprinklers. Any extra heads. Also the condition of tanks, pumps and other water supplies.

Inspections should be made once a week.

FIRE RECORD

The National Fire Protection Association has kept a careful record of all fires in risks equipped with sprinklers since 1897. The following tables, copied from the annual summary for 1918, give data covering 22 years and show in a striking manner the remarkable efficiency of the automatic sprinkler. These records cover 20,097 fires.

TABLE I

Unsatisfactory Sprinkler Fires, Giving Reason for Unsatisfactory Results

	Number.	Per cent.
Water shut off sprinklers.....	241	26.9
Defective equipment and unsprinklered sections.....	204	22.8
Defective water supply.....	85	9.5
System crippled by freezing.....	25	2.8
Slow-operating or defective dry valve.....	19	2.1
Slow or defective operation of high test heads.....	17	1.9
Faulty building construction, concealed spaces, vertical openings, etc.....	39	4.4
Obstruction to distribution.....	54	6.0
Hazards too severe for average sprinkler equipment.....	44	4.9
Explosion crippled sprinkler system.....	37	4.1
Exposure or conflagration.....	63	7.1
Plugged heads and miscellaneous.....	35	3.9
Not classified.....	32	3.6

TABLE II

Number of Sprinklers Operating in Fires

Number of heads.	Number of fires.	Per cent.
1.....	6,234	31.8
2 or less.....	9,448	48.2
3 or less.....	11,437	58.4
4 or less.....	12,873	65.7
5 or less.....	13,796	70.4
10 or less.....	16,212	82.6
20 or less.....	17,768	90.6
30 or less.....	18,351	93.6
40 or less.....	18,623	95.0
50 or less.....	18,796	95.9
75 or less.....	19,034	97.1
100 or less.....	19,149	97.7
Over 100.....	441	2.3

TABLE III
Effect of Sprinklers

	Number.	Per cent.
Practically or entirely extinguished fire...	13,103	65.20
Held fire in check.....	6,099	30.35
Total successful.....	19,202	95.55
Total unsuccessful.....	895	4.45

TABLE IV
Efficiency of Alarm Service, 1897-1918

	Satisfactory.		Failure.		Total.
	No. of fires.	Per cent.	No. of fires.	Per cent.	
Watchmen alone.....	1559	89.7	179	10.3	1738
Sprinkler alarm alone.....	1734	93.8	115	6.2	1849
Thermostats alone.....	182	79.1	48	20.9	230

It will be noted that sprinkler systems failed in less than 5 per cent of the fires.

It is also interesting to note that sprinkler alarm valves failed in only 6 per cent of the fires where they should have operated. Watchmen failed to discover the fire in 10.3 per cent of the cases and thermostats in 21 per cent.

IMPORTANT FIRES

List of a few of the larger fires in risks equipped with automatic sprinklers.

While over 95 per cent of the fires in sprinklered risks were successfully controlled by the sprinkler equipment, there have been some very serious losses in the remaining 5 per cent. A few of the more important of these fires with the reason therefor are of interest.

1893. *Brown Durrell & Co., Essex St., Boston.*

This building was thoroughly equipped with sprinklers and was attacked by a fierce exposure fire. Fire entered through some of the upper windows where shutters were apparently open. The upper floors were gutted, the gravity tank on the roof fell and the main riser was broken off at the fifth floor. Nevertheless, the sprinklers saved the building from complete destruction and prevented the spread of the conflagration.

1895. *Warren Manufacturing Co., Warren, R. I.*

This was a large brick cotton mill of good construction and well equipped with sprinklers except in the engine room. The contract had already been let for equipping this section. Fire started in the unsprinklered engine room and soon gained such headway that when it spread to the sprinklered mill it was beyond control.

Main buildings were destroyed with a loss of \$930,000.

1900. *Porter Screen Co., Winooski, Vt.*

This was a frame woodworking plant consisting of several buildings well equipped with sprinklers. Screen doors were varnished by dipping them in a large dip tank located in a room well partitioned off. The varnish was thinned with naphtha.

Fire occurred in the dip tank, due to the igniting of the naphtha fumes by a broken electric lamp. This tank was not supplied with an overflow pipe or an automatic cover. The sprinklers opened promptly and threw water into the burning tank. The varnish being lighter than the water soon overflowed and flooded the floor of this and the adjoining room. As water had practically no effect on the burning varnish the building was destroyed. Loss \$68,000.

1902. *Estes Press Building, Boston.*

This was a brick building of mill construction used for printing and publishing. A fire occurred and was successfully held by the sprinklers. The fire depart-

ment, thinking the fire was entirely out, shut off the system. The fire, however, had not been completely extinguished and broke out with such fierceness that the building was gutted. Loss \$200,000.

December, 1903. *Sterling Comb Co., Leominster, Mass.*

This was a well built brick building of mill construction used for the manufacture of celluloid combs. It was equipped with a good sprinkler equipment fed by town water under heavy pressure and a gravity tank located on the roof.

Fire started in the stock room, probably due to celluloid on steam pipes. There were about 19 tons of sheet celluloid stock stored in bulk near where the fire started. This caught fire and the sprinklers had little or no effect upon the blaze.

The building was practically destroyed with a loss of \$65,000.

It is a well-known fact that a fire in a large bulk of this material is practically uncontrollable.

March, 1905. *R. B. Grover & Co., Brockton, Mass.*

This was a large frame joisted shoe factory with brick boiler house adjoining. A boiler exploded wrecking part of the building and breaking many of the sprinkler pipes. Fire ensued and completely destroyed the building. There was a large loss of life and an insurance loss of \$226,000.

1906. *Baltimore Conflagration.*

This fire was held at one point largely on account of the O'Neill Department store which was equipped with sprinklers. A few heads in the blind attic opened and the open sprinklers on the windows were used. All buildings on the exposed side were destroyed but the store was open for business two days after the fire.

1907. *Cochecho Manufacturing Co., Dover, N. H.*

This was a large brick cotton mill of plank and timber construction, the timbers being double with a small

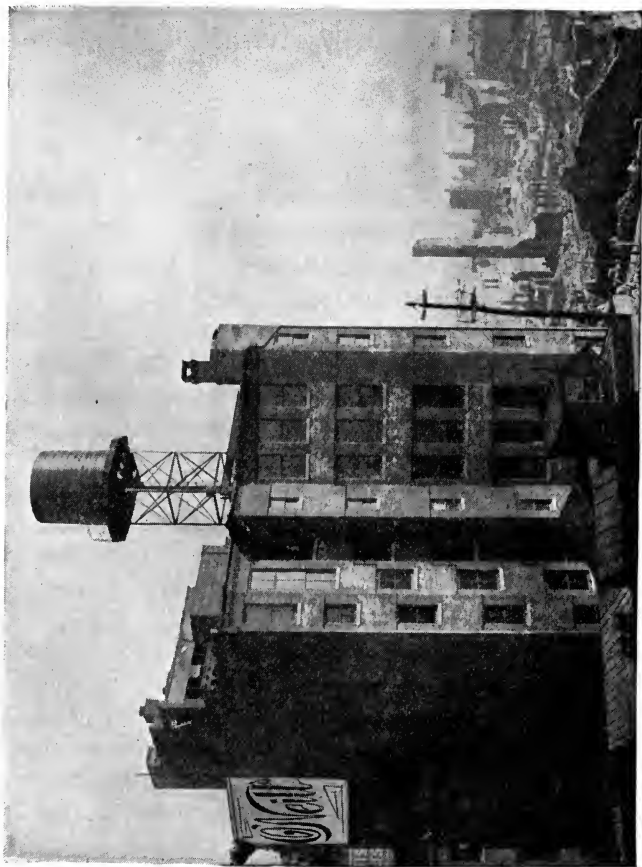

O'NEILL DEPARTMENT STORE AFTER THE BALTIMORE CONFLAGRATION.

space between. Fire started when the sprinkler system was temporarily shut off for repairs. The sprinkler valve was opened but not till the fire had gained such headway as to be beyond control. The loss was considerably increased by the difficulty of extinguishing the fire which worked into the space between the double timbers. Loss \$480,000.

1907. *Shove Mills, Fall River, Mass.*

Cotton Mill. Fire started in engine room and spread rapidly to all floors through large combustible beltways. Loss \$131,000.

1907. *Phelps Publishing Co., Springfield, Mass.*

Large publishing house in the heart of the city. Fire occurred at night and was controlled but not entirely extinguished by the sprinklers. The watchman, thinking the fire out, closed the valve and then telephoned the superintendent for instructions. While he was telephoning the fire broke out again and the building was destroyed. Loss \$535,111.

1909. *A. B. Clark, Peabody, Mass.*

Large frame tannery of light joisted construction. Sprinkler system was shut off through carelessness in the section where fire started. Main building was destroyed with a loss of \$312,000.

1910. *Worcester Bleach & Dye Works, Worcester, Mass.*

Buildings of frame joisted construction. Sprinkler system subject to corrosion and several sprinklers had broken open from this cause. Fire occurred at night and the watchman heard water running from a sprinkler. He closed main valve before investigating, thinking it was a sprinkler leak. Loss \$81,000.

1910. *Herald Co., Ltd., Montreal.*

Newspaper Publishing Plant. Brick building, six stories high located in heart of city. There was a 12,000-gallon gravity tank 17 feet above the roof, supported on a steel trestle. At 11 A.M. when the plant was in full

operation the building suddenly collapsed due probably to overloading of the floors. The weight of the gravity tank may have had something to do with this overloading as the walls were not originally designed to support such a weight. The collapse crippled the sprinkler system and fire ensued probably from stereotype furnaces. Several persons lost their lives and the monetary loss was nearly \$200,000.

1911. *Converse Rubber Shoe Co., Malden, Mass.*

Fire started from unknown cause in two story frame building used largely as a store house. Sprinkler system failed due probably to freezing of the riser in unheated basement, or at alarm valve which was near a window. Loss \$268,000.

1911. *Delohery Hat Co., Danbury, Conn.*

Frame hat factory of poor construction. Fire probably started in driers. Sprinklers failed to hold fire on account of construction and defective (Walworth) sprinklers. Many sprinklers were found after fire with the copper washer stuck to the valve seat. Loss \$45,000.

1911. *Allis-Chambers-Bullock, Ltd., Lachine Locks, P. Q., Canada.*

Two story brick building with plank roof on steel truss. A large 300,000-volt testing transformer was filled with oil and heated outside the building. Fires were drawn from under the transformer and it was brought into the building. The oil was ignited by a spark from the fire and caused a fire which sprinklers could not entirely control. 157 sprinklers opened. Loss \$112,416.

1912. *Rockingham Paper Co., Bellows Falls, Vt.*

A three story brick paper mill largely of mill construction. Part of top floor was supported from roof trusses by iron tie rods. There was a large amount of rag storage on this floor. Fire started in an unsprinklered section and hose streams were used. Part of building

collapsed probably due to weight of water soaked up by the rags. This crippled the sprinkler system and the plant was practically destroyed. Loss \$52,000.

March, 1913. *Champion Coated Paper Co., Hamilton, Ohio.*

Large modern buildings well constructed and protected. Waterworks system was put out of commission by a disastrous flood. The rising water set fire to the building by coming in contact with quicklime. The steam pump could not be started until flood receded as boiler fires had been extinguished. Boilers finally started with rosin and pump was operated under water. Hose streams from pump saved part of plant. Loss over \$600,000.

January, 1914. *Manufacturers' Building, Providence, R. I.*

This was a large 6-story brick building used as a tenant jewelry factory.

Fire was discovered at 4.30 A.M. by the watchman but sprinklers failed to hold it. It was found afterwards that some of the heads had frozen. Building was damaged to the extent of \$92,130, largely by water.

March, 1915. *Woodbury Shoe Co., Derry, N. H.*

This was a 3-story frame shoe factory. Fire occurred at 5.30 A.M., starting in boiler room in a pile of wood waste from a nearby woodworker. Watchman thought fire was out and shut off sprinklers by valve in main building. Fire spread to main building before valve could be opened. Loss \$103,000.

April, 1917. *Dana S. Courtney, Chicopee, Mass.*

This was a frame bobbin and shuttle factory of inferior construction. Fire started in dry room and spread rapidly on account of some sprinklers being shut off for repairs and also because of high test heads and dry system. Loss \$133,900.

October, 1917. *Panther Rubber Co., Stoughton, Mass.*

Frame rubber heel factory of inferior construction. Spontaneous heating of stock in drier opened sprinkler outside dry room. Watchman shut off equipment without thoroughly investigating. Fire spread while sprinklers were shut off and destroyed plant. Loss \$261,096. Also \$52,500 U. & O.

CHAPTER XI

SPRINKLER LEAKAGE

THE subject of sprinkler leakage has of recent years become one of considerable importance, not because of any increase in the loss from leaking sprinklers but from the extension of sprinkler protection to a large number of plants in which the contents are extremely susceptible to water damage, and also because of the extensive advertising that this form of insurance has received. A large number of fire, as well as casualty, companies have recently taken up sprinkler leakage insurance and have been making a strong effort to secure business.

In most states the laws require that sprinkler leakage indemnity be written under a separate policy from that of fire insurance, but in certain cases it is covered by the same policy. Keen competition and a large increase in the business have led during the past few years to a considerable lowering of rates.

Leaking sprinklers and those that open prematurely, owing to defects in construction, are responsible for a very small proportion of the total losses, as modern sprinklers very rarely cause damage in this way. Losses are more apt to be due to trouble in other parts of the system as there is always a large amount of piping and fittings constantly under heavy pressure, in addition to any tanks that may be connected to the system.

In practice the most common cause of loss is freezing. This is most likely to occur during cold snaps that come on Sundays and Holidays, and in buildings that are left unguarded at such times. In some cases the

trouble has been due to leaving some part of a building improperly protected against the weather, during repairs. Sprinkler heads and small piping located near doors or windows and in monitors are especially subject to freezing. Risers or pipes in unheated basements and low spaces under buildings, also pipes running from one building to another, have frequently caused trouble from not being properly boxed. Freezing is more likely to occur in plants having no watchman than in those where there is some one on duty at all times.

Perhaps the next most important cause for loss is the deterioration of the system from age, poor care or corrosion. Some of the older makes of sprinkler heads give trouble from the effects of age, and break open owing to weakness of the solder joint. This is especially the case in places where the water pressure is high and subject to great fluctuations. Certain sprinklers are recognized as being defective and liable to open under constant strain. Amongst those are the Walworth single link heads, the Grinnell metal disc sprinklers, the International type A (narrow link) and the Rockwood type A. None of these heads are now being installed and most of them have already been replaced. The cracking of the glass discs in the Grinnell sprinklers installed between 1890 and 1896, before the annealed glass was used, has also caused some sprinkler leakage losses.

Many losses have been occasioned by tanks, especially wooden gravity tanks with flat hoops. These hoops are very susceptible to corrosion and if this is allowed to go far enough it will result in the collapse of the tank. Many tanks have fallen owing to the weakening of the supports. This may be due to rotting of wooden beams under the tank or to corrosion of the steel trestle. A few bad accidents have occurred from the settling or cracking of a brick wall supporting a tank. Pressure tanks

have also given some trouble by settling, on account of improper support. This generally results in the breaking of some fitting in the discharge pipe.

Sprinkler piping has been broken by the settling of a building due to inadequate foundations or poor workmanship. Breaking belts have been the cause of many

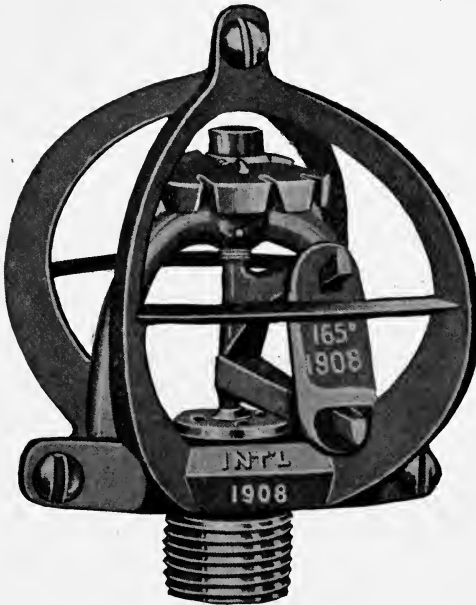

"INTERNATIONAL" SPRINKLER

Closed, with Guard Attachment

losses. Any belt running close to a sprinkler pipe of small size is a source of danger and those encircling a pipe are particularly bad as they are almost sure to injure the piping if they break. Sprinkler heads or small pipes are occasionally broken by careless handling of stock, as, for instance, by throwing shoe lasts into bins. Pendent heads are much more likely to be injured in

this way than upright heads. Sprinklers thus exposed should be protected by metal guards.

Sprinklers have sometimes been opened by the focusing of the sun's rays upon them through the thick glass of a skylight. This is more apt to occur where there is a curtain under the sprinklers which tends to confine the heat.

Sprinklers of too low a fusing point are sometimes installed in hot places like boiler rooms and later open from the long-continued strain under too high a temperature. Even more common is the opening of sprinklers owing to the introduction of some hot process into a room where the heads were not installed with this in view. Frequently a muffler or some form of drying machine is installed without changing the sprinklers for those of a higher test and as a result, some of the heads have fused.

Sprinkler piping has sometimes been ruptured owing to an insufficient number, or to poor quality, of hangers, or to defects in the supports to which they are fastened.

The following are some of the important points that should be investigated in inspecting a plant for sprinkler leakage insurance.

SPRINKLER LEAKAGE REPORT

Occupancy. (Sprinkled portions only.) Raw stock; is
 Goods mfrd
 Contents comprising at least 33% of total value consist of
 Greatest value consists of
 located
 Stock, goods, skidded in Piled too high
 Values in basements light, moderate
 considerable large.
Occupancy. (Full details.) Sub-basement
 Basement First Second Third
 Fourth Fifth

Pipe System. Joints between cast and steel pipe properly strapped. Not, leaky. Main pipe to riser buried, overhead.

Hangers, good, fair, poor type; well screwed, nailed up. More needed. Some, no, bushed fittings.

Main to riser well supported. Hangers in fire proof floors fastened by (give details)

Valves. Main valves outside, well located; not readily accessible, obstructed in

Necessary to close two valves to shut off sprinklers.

Valves on each riser in bmt. 1st. each floor. Test pipe cannot cause damage.

Drip valves well arranged; drain to

Drips sealed by city.

Tank. Gravity, pressure, wood, steel gals. capacity;

Age, located over, inside building. ft. above.

On ft. steel, wood, trestle; located on ft. from

bldg. Cond. of trestle, e. g. f. i. p. Footings,

e. g. f. i. p.

Supported from ground on brick, wood walls;

in. thick, on columns in e. g. f. i. p. condition.

Condition of tank e. g. f. i. p. Hoops round, flat, ample. Cond.

e. g. f. i. p. Corroded

Pipe from tank properly braced; supported by

No, Provision for expansion by expansion joint, two elbows, slip joint at tank bottom.

Overflow well arranged; discharges to

Protection from freezing, good, fair, indif., poor (see above).

Liability to Breakage. *Piping, Sprinklers:* none, slight, considerable, from poor supports, corrosion, belts, stock piling, defective heads.

Pendent sprinklers subject to injury in

Sprinklers guarded where necessary.

High test sprinklers where needed. Low test heads too

near steam coils, liable to overheating in

Liability to Freezing. None, slight, considerable in

Buildings are heated by steam; hot water; hot air; pipes overhead, at sides. Sprinklered blind spaces

properly heated by

Heating, none, inadequate, unreliable, doubtful in (spkld. rooms only).

Building not tight at eaves, walls, Pipe entering building, Riser not properly protected.

Heating plant outside, at risk. Fireman maintained nights, Sundays and holidays. Boiler feed safely arranged. Ample coal supply.

Dry valve not, properly heated. Dry pipes do not drain. More drips needed.

System not kept, found, free of water.

Necessary to shut off sprinklers in winter in

Cold weather valves located in warm places. Drain adequate; open. Pipes are free from water; good condition. No. vacant rooms.

Note. This is a scratch blank and the items which apply are scratched.

Abbreviations: — *e*, excellent; *g*, good; *f*, fair; *i*, indifferent; *p*, poor.

**FORM OF SPRINKLER LEAKAGE INSURANCE POLICY
IN GENERAL USE**

THE.....INSURANCE CO.

In Consideration of the Terms and Stipulations herein named

and of.....Dollars Premium

Does insure

.....for the term of.....

from the.....day of.....19..... at noon,

to the.....day of.....19....., at noon, standard time at the place where the property herein described is located, against all direct loss or damage by sprinkler leakage, except as hereinafter provided, to an amount not exceeding

.....Dollars,

to the following described property while located and contained as described herein, and not elsewhere, to wit

.....
.....
.....
.....

Subject to the following stipulations and conditions:

Wherever in this policy the word "insured" occurs, it shall be held to include the legal representatives of the insured; wherever the word "loss" occurs, it shall be deemed the equivalent of "loss or damage;" wherever the term "sprinkler leakage" occurs, it shall be held to mean leakage, discharge or precipitation of water from the automatic sprinkler system, or tanks supplying it (including accident caused by freezing), in or on the buildings now erected and described herein, whether the accident occurs in the portion occupied by the insured or not.

This company shall not be liable for loss by fire, however caused; nor for loss resulting from the leakage of water, if such leakage is caused directly or indirectly by fire; nor for loss due to stoppage or interruption of any work or plant unless liability for such loss is specifically assumed herein; nor for loss caused by lightning (whether fire ensues or not), cyclone, tornado, wind-storm, earthquake, explosion, or blasting; nor for loss caused directly or indirectly by invasion, insurrection, riot, civil war or commotion, or military, or usurped power, or by order of any civil authority; nor for loss by theft; nor for loss caused directly or indirectly by the neglect of the insured to use all reasonable means at the time of an accident to save and preserve the property; nor for loss caused directly or indirectly by the fall or collapse of any building or any part thereof, unless such fall or collapse is caused by the accidental leakage of water from the automatic sprinkler system, or the tanks supplying it.

This company shall not be liable for loss to accounts, bills, currency, deeds, evidences of debt, money, notes or securities; nor to an amount exceeding ten per cent of this policy for loss to patterns, models, plans and lasts, unless liability is specifically assumed thereon for a stated amount under a separate item mentioning no other kinds of property.

This company shall not be liable beyond the actual cash value of the property at the time any loss occurs, and the loss shall be ascertained or estimated according to such actual cash value, with proper

deduction for depreciation however caused; and shall in no event exceed what it would then cost the insured to repair or replace the same with material of like kind and quality; said ascertainment or estimate shall be made by the insured and this company, or, if they differ, then by appraisers, as hereinafter provided; and, the amount of loss having been thus determined, the sum for which this company is liable pursuant to this policy shall be payable sixty days after due notice, ascertainment, estimate (including an award by appraisers when appraisal has been required), and satisfactory proof of the loss have been received by this company in accordance with the terms of this policy. It shall be optional, however, with this company to take all, or any part, of the articles at such ascertained or appraised value, and also to repair, rebuild or replace the property lost or damaged with other of like kind and quality within a reasonable time on giving notice, within thirty days after the receipt of the proof herein required, of its intention so to do; but there can be no abandonment to this company of the property described.

Ordinary minor repairs and alterations usual and necessary to the care and maintenance of the automatic sprinkler system, building or premises are allowed, but this company shall not be liable for any loss resulting from unusual repairs or extensions to or alterations in the automatic sprinkler system, the buildings, or the premises, unless otherwise provided by agreement endorsed hereon or added hereto.

This policy shall be void if the property described herein is sold as a whole, or this policy assigned, without the written consent of this company endorsed hereon, or if the insured has concealed or misrepresented any material fact or circumstance, concerning this insurance or the subject thereof. If a building herein described be or become vacant or unoccupied, all liability thereon under this policy shall immediately cease, unless otherwise provided by agreement endorsed hereon or added hereto.

In the event of loss covered by this policy, the insured shall give immediate notice thereof in writing to this company, protect the property from further damage, forthwith separate the damaged and undamaged personal property, put it in the best possible order, make a complete inventory of the same, stating the quantity and cost of each article and the amount claimed thereon; and within sixty days after the date of the leakage, unless such time is extended in writing by this company, shall render a statement to this company, signed and sworn to by the said insured, stating the knowledge and belief of the insured as to the time and cause of the leakage; the interest of the insured and of all others in the property; the cash

value of each item thereof and the amount of loss thereon; all encumbrances thereon; all other similar insurance, whether valid or not, covering any of said property.

The insured, as often as required, shall exhibit to any person designated by this company all that remains of any property herein described, also specifications of the buildings, machinery or fixtures, destroyed, damaged or injured, and submit to examinations under oath by any person named by this company, and subscribe the same; and, as often as required, shall produce for examination all books of account, bills, invoices, and other vouchers, or certified copies thereof if originals be lost, at such reasonable place as may be designated by this company or its representative, and shall permit extracts and copies thereof to be made.

In the event of disagreement as to the amount of loss the same shall, as above provided, be ascertained by two competent and disinterested appraisers, the insured and this company each selecting one, and the two so chosen shall first select a competent and disinterested umpire; if no umpire be selected within fifteen days after the selection of appraisers, their power and authority shall cease and new appraisers shall be selected in the manner herein provided. After having chosen an umpire, the appraisers together shall then estimate and appraise the loss, stating separately sound value and damage, and, failing to agree, shall submit their differences to the umpire; and the award in writing of any two shall determine the amount of such loss; the parties thereto shall pay the appraiser respectively selected by them and shall bear equally the expenses of the appraisal and umpire.

This company shall not be held to have waived any provision or condition of this policy or any forfeiture thereof by any requirement, act or proceeding on its part relating to the appraisal or to any examination herein provided for.

This company shall not be liable under this policy for a greater proportion of any loss on the described property than the amount hereby insured shall bear to the whole insurance, whether valid or not, or by solvent or insolvent insurers, covering such property, and the extent of the application of the insurance under this policy or of the contribution to be made by this company in case of loss, may be provided for by agreement or condition written hereon or attached or appended hereto. Liability for reinsurance shall be as specifically agreed hereon.

If this company shall claim that the loss was caused by the act or neglect of any person or corporation, private or municipal, this company shall, on payment of the loss, be subrogated to the extent

of such payment to all right of recovery by the insured for the loss resulting therefrom, and such rights shall be assigned to this company by the insured on receiving such payment, or the insured, if required, shall prosecute therefor at the expense and for the account of this company.

This policy shall be canceled at any time at the request of the insured; or by the company by giving five days notice of such cancellation.

If this policy shall be canceled, as hereinbefore provided, or become void or cease, the premium having been actually paid, the unearned portion shall be returned on surrender of this policy, this company retaining the customary short rate premium; except that when this policy is canceled by this company by giving notice it shall retain only the *pro rata* premium.

This company shall be permitted at all reasonable times to inspect the premises or property insured hereunder, but by so inspecting assumes no liability beyond that expressed herein.

No suit or action on this policy, for the recovery of any claim, shall be sustainable in any court of law or equity until after full compliance by the insured with all the foregoing requirements, nor unless commenced within twelve months (unless otherwise provided by statute or other legal regulation) next after the leakage causing loss claimed.

This policy is made and accepted subject to the foregoing stipulations and conditions, together with such other provisions, agreements, or conditions as may be endorsed hereon or added hereto, and no officer, agent or other representative of this company shall have power to waive any provision or condition of this policy except such as by the terms of this policy may be the subject of agreement endorsed hereon or added hereto, and as to such provisions and conditions no officer, agent or representative shall have such power or be deemed or held to have waived such provisions or conditions unless such waiver, if any, shall be written upon or attached hereto, nor shall any privilege or permission affecting the insurance under this policy exist or be claimed by the insured unless so written or attached.

No change in this policy shall be valid unless made in writing by a duly authorized agent of this company.

In Witness Whereof, this company has executed and attested these presents this.....day of.....19....but this policy shall not be valid until countersigned by the duly authorized Agent of the company at.....

.....

Reduced Rate or Coinsurance Clause.

This Company shall not be liable for a greater proportion of any loss or damage to the property described herein than the sum hereby insured bears to.....per centum (.....) of the actual cash value of said property at the time such loss shall happen.

In case of claim for loss on the property described herein not exceeding five per cent (5%) of the maximum amount named in the policies written thereon and in force at the time such loss shall happen, no special inventory or appraisalment of the undamaged property shall be required.

If the insurance under this Policy be divided into two or more items, these clauses shall apply to each item separately.

CHAPTER XII

AUTOMATIC SPRINKLERS AS A PROTECTION TO LIFE

The automatic sprinkler is without question the most important fire protection device ever invented. This is due to the fact that it is constantly on duty in every part of the property equipped and is automatic in its action. Practically every fire is small at the start and can be put out at that time with a small amount of water. The sprinkler is able to supply this water at just the time it is needed without the intervention of any human agency. The device itself has been so perfected that it practically never fails to operate when needed, provided only that it is properly installed and maintained.

The proof of its value is found in the fact that today a majority of the large manufacturing plants if of a hazardous nature are equipped with automatic sprinklers. In some extra hazardous industries, like the celluloid comb business, it is almost impossible to obtain fire insurance unless the building is sprinklered.

The value placed upon the device by the insurance companies is accurately reflected in the rates charged. A manufacturing plant paying a rate in the neighborhood of 1 per cent per year can be insured for about $\frac{1}{10}$ of 1 per cent, generally speaking, if equipped with a standard sprinkler system, and this tremendous difference is justified by the fire record. Out of 20,097 fires in sprinklered plants tabulated by the National Fire Protection Association during the last 22 years, only 4.45 per cent were not controlled by the equipment.

In nearly all of these cases there was some good reason for the failure, such as a closed valve, frozen pipe, defective water supply, etc. Given a standard equipment, under proper maintenance, with adequate water supplies, in a building of even fair construction, and the automatic sprinkler is practically certain to control any fire that may occur.

Up to a few years ago, sprinklers were more or less of an experiment but they have now been successfully used for 40 years and their efficiency can no longer be questioned. It is a noteworthy fact that in all the fires in sprinklered buildings, there has been practically no loss of life. In the Grover Shoe Factory fire in Brockton in 1907 it is true that several lives were lost but this was due primarily to the explosion of the boiler. In the Herald Building fire in Montreal in 1910, there was also a loss of life but this was due to the collapse of the building that preceded the fire. The records of the Factory Mutual Insurance Companies covering risks employing 1,500,000 people show only 12 deaths in sprinklered buildings in 38 years. Of these 3 were due to persons going back into a burning building to save property and 4 were firemen engaged in fighting the fire. There may be a few other isolated cases but they are so rare that they only go to prove the rule.

This being the case, it is indeed strange that the sprinkler has not been more frequently installed as a life saver. Practically all the equipments thus far installed have been for the protection of property and a large majority of them have been installed primarily because they were a good investment. In practically every case a sprinkler equipment will pay from 10 to 30 per cent upon the money invested on account of the saving in insurance premiums. It is a sad commentary upon the intelligence of the American public that,

were they not of financial benefit, comparatively few sprinkler equipments would ever have been installed. Up to quite recently practically the only agency that has been responsible for the growth of sprinkler protection is fire insurance. But the gradual awakening of the American public to our scandalous fire waste, both of lives and property, is beginning to have its effect, and a few property owners are beginning to look at the subject from a broader point of view.

Public opinion is already beginning to take the form of legislation in a few places and this is only the beginning of a widespread movement. The Massachusetts State Police are now draughting a proposed law, primarily for the safeguarding of life, that will require automatic sprinklers in all celluloid working plants hereafter erected in the Commonwealth. New York City is requiring automatic sprinklers or perforated pipes in certain basements in congested sections. Just why the antiquated perforated pipe, which is not automatic in its action, is put on the same basis as the modern automatic sprinkler is not clear; but the fact that some better form of protection than the hose stream was found necessary in these inaccessible places is a sign of the times. Several cities have similar ordinances relating to the stages of theatres.

The Boston Chamber of Commerce appointed a committee on Fire Prevention a few years ago and after giving the matter long and careful study they made the following recommendation in their report of 1911.

“The passage of a law requiring all second- and third-class buildings now existing within the congested business district of the city to be equipped with sprinkler service, except that houses for habitation not used in any portion for any other purpose need not be so equipped, and that hotels and lodging houses need be so equipped only in the basement, first story, public halls, dining rooms and assembly rooms.”

Public sentiment does not yet seem to have reached the point where such drastic legislation can be passed but the time is surely coming when the public will wonder why such laws were not put into effect long ago.

It should not need another Bighamton or Triangle Waist horror to prove the necessity of this effective and inexpensive form of protection in every factory, whatever its construction, where light, inflammable material is worked. It should not require another Collingwood School holocaust to point out the necessity of automatic sprinklers in the basements and stairways of combustible school buildings. It should not require another *General Slocum* or *Volturno* disaster to demonstrate the practicability of safeguarding the lives of precious human freight by such a simple means as the sprinkler. It should not require another Baltimore conflagration to prove the desirability of equipping all stores having highly combustible contents with this ever-present safeguard. It is not only practical and inexpensive but in most cases a saving of money to equip all such structures and thus reduce the chance for loss of life to as low a point as modern science can devise.

The time is surely coming when automatic sprinklers will be required in all hazardous manufacturing plants, in all large retail stores, in all non-fireproof buildings in congested districts, in theatres, in school houses and even in combustible ships just as surely as proper means of exit are now required in similar places.

CHAPTER XIII

COMBINED HEAT AND SPRINKLER SYSTEMS

It is a curious fact that in the first automatic sprinkler system ever installed an effort was made to combine a heating system with the sprinkler system and that no serious attempt was made to repeat this experiment until very recently. The system in the Parmelee Piano Factory in New Haven, installed in 1874, was used for heating in extremely cold weather. There was an auxiliary system of steam pipes of sufficient capacity to heat the building in moderate weather, but in very cold weather steam was let into the sprinkler pipes. The sprinkler heads were placed upon inverted U pipes to form a trap which would remain full of water and thus keep the steam from heating the heads unduly. The Parmelee system of piping, being a "tree" system, was especially adapted for this purpose, for the heat that circulated in the main feed pipes would not cause much circulation in the branch pipes in which the sprinklers were located.

There were three feed lines running lengthwise of the building with cross feeders at the ends and in the center. At the end of each cross feed was a pipe with a valve extending out of doors. These were used to bleed the system and start a circulation when the steam was let in. The system was not entirely satisfactory and the steam connection was finally abandoned.

No further attempt along this line was made so far as is known until about 1910 when the weave shed of a New Bedford Cotton Mill was piped with a system that could be used both for sprinkler and heating purposes. The building was of large area (about 300 by 237 ft.) and basement and one story in height. The system was

fed by an 8-inch connection from the yard mains supplied by the city water and a steam pump. A check valve was installed in this connection just inside the building.

In the basement the entire piping system was used for heating purposes and there were no auxiliary heating pipes. Check valves were placed on the larger branch lines near the main feed line to prevent circulation in the latter. The ends of the branch lines were tied together and connected to two 4-inch headers or supply pipes from a hot water heater.

The weave shed occupying the 1st floor had a saw-tooth roof not so well adapted to this form of heating. No attempt was made here to utilize the small sprinkler pipes, running to the top of each saw tooth, for heating purposes, but the heat was obtained by the circulation through the larger feed pipes and some auxiliary heating coils.

The heater was located in the basement of an adjoining engine room and the circulating water was here heated by steam. Circulation was effected by means of a pump. The heated water starting in a 4-inch pipe circulated through the sprinkler pipes and auxiliary heating pipes returning through another 4-inch pipe.

One of the most important problems in such a system is to insulate the sprinkler heads sufficiently to prevent them from becoming overheated and fusing. The average temperature of the water in this system was figured at 180° to 200° F. with a possible maximum of 245° F. As sprinkler solder melts at 160° F., it is evident that means must be taken to prevent the sprinkler heads from reaching the temperature of the circulating water. This was accomplished by using $\frac{1}{2}$ -inch offsets about 12 inches long. These were screwed to the top of the sprinkler pipe and the sprinkler head was attached to the other end. This brought the sprinkler about 3 inches

above the main pipe. It was found by tests that these offsets soon became filled with air and nitrogen gas which acted as an insulator and prevented the sprinkler

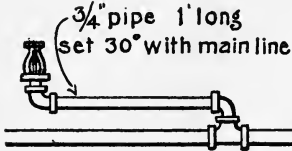

STRAIGHT OFFSET.

from becoming too hot.

This system worked satisfactorily and so far as known no trouble has occurred.

Certain patents were taken out on this system by Pierce Bros., who owned the mill, and later patents covering similar systems were taken out by others.

In 1913 the plant of Gray & Davis at Cambridge was equipped with a similar system by the General Fire Extinguisher Co. In this system the offsets were $\frac{3}{4}$ inch instead of $\frac{1}{2}$ inch as in the earlier system, as $\frac{1}{2}$ -inch pipe is too small for good sprinkler protection. These offsets were 12 inches long, placed at an angle of 30 degrees with the feed pipe instead of being placed parallel to it. These were probably not quite as effective for insulating as the smaller pipes. In this system a connection was made between the sprinkler piping and a domestic service connection through a small pipe in order to take care of contraction and expansion. The system was somewhat complicated by having two main risers, each containing an alarm valve, and these were tied together above the alarm valves. In order to shut the water off from any sprinkler it was necessary to shut the two main controlling valves and a hot water feed valve. During a very cold snap the first winter the heating system was forced in order to keep the building warm and as a result two sprinkler heads near a main riser opened from overheating. The offsets on all heads near main risers were then lengthened and no further trouble has occurred.

The early installations were made by the Pierce Ham-

mond Co. who controlled the patents of the Pierce Bros. and W. B. Hammond.

In 1914 the business of installing such systems was pushed by the Combined Heat and Sprinkler Co. of Boston, which controlled the Chatman and Nutter patents. Several sprinkler companies were licensed to install their system on a royalty basis and during 1914 and 1915 over 15 equipments, largely in New England, were installed.

In these equipments, curved offsets known as "ram's horns" were used instead of straight offsets for insulating the sprinkler heads. The Rockwood Sprinkler Co. used a compound curve while the G. M. Parks Co.

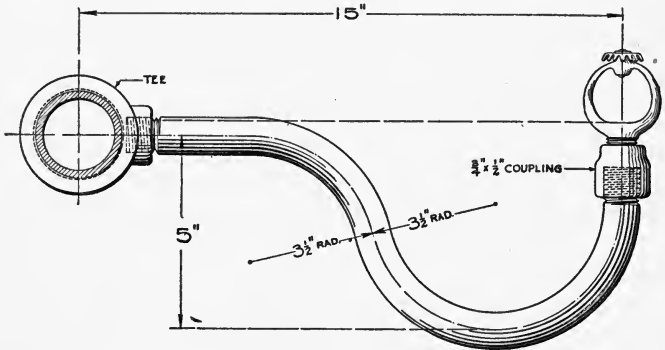

FOR SHALLOW PANEL, OR FLAT CEILING CONSTRUCTION

COMBINED HEAT AND SPRINKLER CO.
CURVED OFFSET.

used a simple curve. These offsets took out from the side of the sprinkler pipe, curved downwards about 5 inches and then upwards about the same amount, bringing the sprinkler head about on a level with the sprinkler feed pipe. This formed a water trap through which but little heat could reach the sprinkler.

In some tests made to determine the temperature of water in different parts of the offset it was found that with a room temperature of 86° F., and a temperature of water in the sprinkler feed pipe of 238° F. the following results were obtained.

With Parks offset, simple curve 18 inches long.

Temperature of water in offset at first bend, 190 degrees.

Temperature of water in offset at second bend, 110 degrees.

Temperature of water in offset at third bend, 104 degrees.

Temperature of sprinkler head, 102 degrees.

With Rockwood offset, compound curve 22 inches long.

Temperature of water in offset at first bend, 180 degrees.

Temperature of water in offset at second bend, 98 degrees.

Temperature of sprinkler head, 100 degrees.

As a matter of fact this was a somewhat excessive temperature in the feed pipes as 220 degrees is recommended as a maximum. The superior results in the Rockwood offset is due largely no doubt to its greater length.

Tests were also made upon the effects of freezing by allowing the temperature in the room to fall to 22° F. while the water in the circulating pipes was 85 degrees. After a five hour run the water in the ends of the offset was frozen but in no case was the pipe split or the sprinkler head injured. With a temperature of 120 degrees in the circulating pipe slight freezing occurred in some cases. With a temperature of 172 degrees in the pipe no freezing occurred.

The ram's horn offset does not comply with the sprinkler rules as it prevents complete drainage of system.

The earlier equipments were somewhat complicated

by a multiplicity of controlling valves both on the sprinkler and heating pipes. The later equipments were somewhat simplified and in most cases one valve was sufficient to control the entire equipment.

The trouble from possible overheating of the sprinkler heads was largely overcome by the use of the curved or ram's horn offset although there was one case where trouble occurred owing to defective workmanship. This was in the building of the Worcester Building Trust at Worcester, Mass. Grinnell sprinklers were installed by G. M. Parks & Co. on compound curved offsets. During the first winter this equipment was in place (1914-1915) there was some trouble from lack of heat in the building. The next summer a larger boiler was installed. On December 11, 1915, just after the first cold snap of the season, a sprinkler on the fourth floor and one on the fifth floor opened almost simultaneously at 9.45 A.M. Investigation showed that the offsets on these two heads as well as several others in the building were defective, or rather had been installed wrong end to. These offsets were changed and no further trouble occurred.

During 1916 and 1917 there was patent litigation between the Pierce Hammond Co. and Combined Heat and Sprinkler Co. and but few equipments were installed. This litigation has now been settled and a working agreement has been reached between the two companies. The Combined Heat and Sprinkler Co. expects to push the business again in the near future.

Heating Properties. The radiating surface of sprinkler pipes as ordinarily installed is about 60 per cent of that required to keep a room at a temperature of 70° F. This will vary a good deal depending on the height of the room, the window surface and other factors but the figure is probably a fair average. Where this temperature is desired with a combined system it is therefore necessary to use auxiliary heating pipes or else to enlarge

the sprinkler pipes. Auxiliary pipes are usually installed and these are quite independent of the sprinkler pipes. The sprinkler pipes are well located for heating purposes as they afford an excellent distribution of the radiating surface.

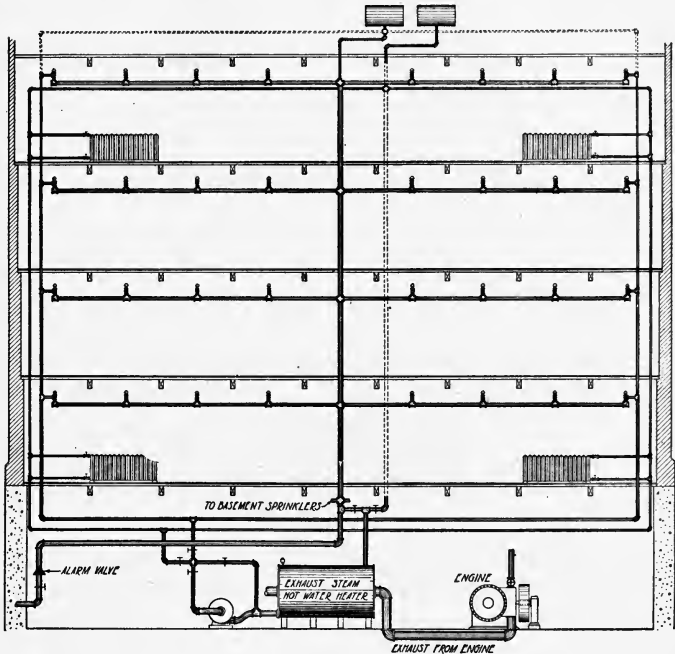

COMBINED HEATING AND SPRINKLER SYSTEM.
(Sectional view showing arrangement of piping.)

Circulation of Water. In most of the equipments already installed a pump has been used for circulating the water. The tendency, however, is toward gravity systems with no pump. These are practical in many buildings of moderate area, say 16,000 square feet to the floor or less and of three stories or more in height.

In most cases a centrifugal pump has been used, this being noiseless and creating no water hammer.

The branch lines are generally enlarged to $1\frac{1}{2}$ or 2 inches and are all tied together. These are then connected to auxiliary risers or return pipes so as to give a complete circulation. The details vary greatly according to local conditions but the return pipes are all connected to a return main and the pump is located in this main near the heater. Various forms of heaters are used.

Expansion. Some arrangement is needed to care for expansion and contraction, as water heated from 40° to 250° F. will expand nearly 5 per cent of its volume. In some equipments this can be regulated by an expansion tank located above the highest pipe as in ordinary hot water heating systems. In other cases it is taken care of by means of a small by-pass around the check valve on the sprinkler supply. This by-pass contains a check valve, usually $\frac{1}{2}$ inch in diameter and punctured with a $\frac{1}{4}$ -inch hole. It points in the opposite direction to that of the large check. Such an arrangement will not interfere with the proper action of the alarm valve, if there is one in the system. The expansion when the water is heated is much more rapid than the contraction when it cools and therefore a larger outlet than inlet is necessary in the by-pass. This is accomplished by the half-inch check containing a quarter-inch hole. In some cases a relief valve has also been installed on the system to care for excessive expansion.

The operating temperature of the water should vary from 100 to 220 degrees. This can be automatically controlled.

Advantages. The principal advantage claimed for the system is economy in original cost of installation and economy in operation. In small equipments, say 300 heads or less, there is seldom or never any economy in first cost but in larger equipments this may run from 5 to 30 per cent. The saving in maintenance is due to

the fact that the use of hot water is generally more economical than steam although it requires larger pipes and therefore greater initial cost. The distribution of heat is more even than where the pipes are arranged in banks, although piping at the ceiling level does not give quite as economical a method of radiation as do pipes on the wall.

Other advantages claimed are as follows: There is less liability of serious obstructions remaining in the pipes without being discovered as they would prevent circulation and the pipes would remain cold where obstructed. The lack of dead ends in the sprinkler pipes gives less friction loss and better distribution of water. The chance of false alarms from alarm valves should be minimized on account of the lack of entrapped air in the pipes.

Disadvantages. Amongst the possible disadvantages may be noted the following:

1. Additional chance for shutting off the sprinkler system due to repairs. A system used for two purposes would generally be more likely to need repairs than if only used for one purpose. The expansion and contraction due to changes in temperature would tend to make the piping leak more than where temperature was more constant. On the other hand repairs are more apt to be made promptly.

2. Complication of valves and need of shutting more than one valve to shut off water from sprinklers. This has been largely overcome in many of the later equipments.

3. Chance of clogging of the trap in the offsets by mud and sediment carried by the circulating water. Where water is impure a mud drum should be installed and the tests of the Underwriters' Laboratories seem to show that this will generally prevent trouble in the offsets.

There is also the feature of using hot water to extinguish a fire. While the cold water would soon follow the discharge of hot water in case a fire occurred it is a fact that hot water is not as good a fire extinguisher and might cause some inconvenience to any person who was near enough to be wet by the first discharge from the sprinkler.

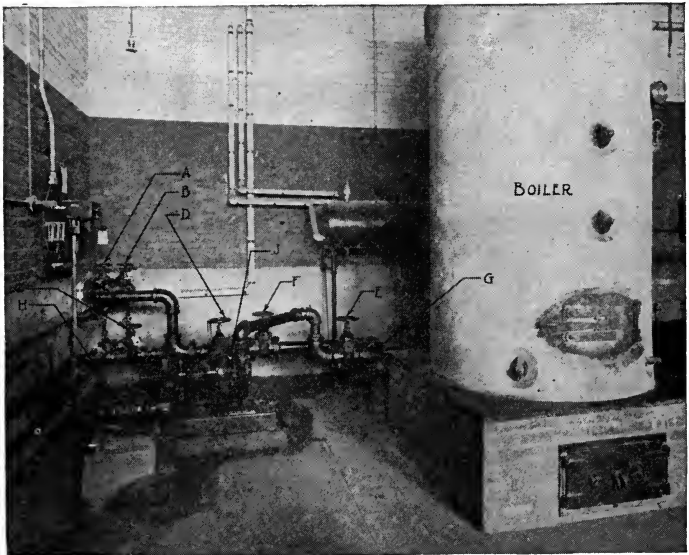

COMBINED HEATING AND SPRINKLER SYSTEM — PUMP AND HEATER.

There is also a possibility that hot water might be slightly detrimental to the rubber faces of alarm valves should the circulation be allowed to come too close to these devices.

The matter of corrosion of the interior of the sprinkler piping is a matter needing more field experience, but the general opinion amongst manufacturers of heating devices seems to be that there should be little if any trouble from this cause.

Conclusions. The Combined Heat and Sprinkler Co. system was thoroughly tested by the Underwriters' Laboratories in Chicago and approved by them in 1917.

A field experience of about 7 years seems to prove that the system is commercially successful and is economical under certain conditions. In buildings less than 50 feet wide and in equipments of less than 300 heads it is usually not economical in regards to first cost. It is particularly desirable in buildings that otherwise would be piped on a dry system because it does away with the inherent undesirable features of such systems, namely: chance of freezing in pockets in the piping and other parts of the system, care in keeping air pressure pumped up, and delay in getting water at a sprinkler head after it has fused. Experience has shown that such a system is not suitable for show windows of a department store.

Installations. The following is a brief description of some of the early installations.

Pierce Bros., Ltd., New Bedford, Mass.

Basement and one-story weave shed, about 300×237 feet. Grinnell sprinklers used on $\frac{1}{2}$ -inch straight offsets about 12 inches long. Water circulated by pump.

Bates Mfg. Co., Lewiston, Maine.

Two-story weave shed, 325×525 feet, and of fireproof construction. Grinnell heads used on straight $\frac{3}{4}$ -inch offsets.

Installed by the General Fire Extinguisher Co.

Gray and Davis, Cambridge, Mass.

Five-story fireproof building, 382×62 feet. Grinnell sprinklers on $\frac{3}{4}$ -inch straight offsets. Installed by General Fire Extinguisher Co. Circulation by centrifugal pump. Expansion taken care of by by-pass.

Installed by the General Fire Extinguisher Co.

Brewer & Co., Fall River, Mass.

Two- and three-story brick wholesale drug house. Area, 90 × 100 feet. Rockwood sprinklers on compound curve offset. Circulation by gravity. Expansion through by-pass and relief valve.

Installed by Rockwood Sprinkler Co.

Worcester Building Trust, Worcester, Mass.

Basement and eight-story fireproof building of about 16,000 square feet ground area. Grinnell sprinklers on single curve offset. Circulation by pump. Expansion through by-pass and relief valve.

Installed by G. M. Parks Co.



COMBINED HEATING AND SPRINKLER SYSTEM IN PLANT OF
WHELOCK LOVEJOY & Co.

Wheelock Lovejoy & Co., Cambridge, Mass.

One-story mill constructed building, 170 × 200 feet. Rockwood sprinklers on compound curve offsets. Cir-

ulation by electrically driven centrifugal pump. Expansion through $\frac{1}{2}$ -inch by-pass. Relief valve also used.

Installed by Rockwood Sprinkler Co.

Outlet Co., Providence, R. I.

Basement and six-story fireproof building, 180 × 110 feet. Grinnell heads on single curve offset. Circulating pump installed but not used. Expansion through by-pass and relief valve.

Installed by G. M. Parks Co.

Fore River Ship & Engine Co., Quincy, Mass.

Four-story building, about 100 × 200 feet. Grinnell heads on single curve offset. Circulation by gravity. Two separate systems with P. I. V. control. Expansion through by-pass.

Installed by G. M. Parks Co.

Albert Geiger, Jr., Three Garages, Commonwealth Ave., Boston, Mass.

Basement and four stories fireproof construction. Rockwood sprinklers on compound curve offset. Gravity circulation. Expansion through by-pass and relief valve.

Installed by Rockwood Sprinkler Co.

Barton Store, Manchester, N. H.

Basement and six-story building, 100 × 150 feet. Rockwood sprinklers on compound curve offset. Circulation by pump. Expansion through by-pass.

Installed by Rockwood Sprinkler Co.

Rockwood Sprinkler Co., Worcester, Mass.

Three-story building, 240 × 110 feet. Rockwood sprinklers on compound curve offset. Circulation by gravity. No auxiliary heating pipes used. Expansion through by-pass and relief valve.

Installed by Rockwood Sprinkler Co.

Essex Associates, Haverhill, Mass.

Basement and eight-story building, 200 × 50 feet.
Grinnell sprinklers on single curve offset. Gravity circulation. Expansion through by-pass.

Installed by G. M. Parks Co.

CHAPTER XIV

SYPHO CHEMICAL SPRINKLER SYSTEM

GENERAL DESCRIPTION

This device which was approved by the Underwriters' Laboratories December 19, 1916, is made by the Sypho Chemical Sprinkler Corporation of New York of which Mr. E. L. Thompson of the Automatic Sprinkler Co. of America is president. It is an automatic extinguishing device designed for moderate areas and to extinguish fires that are subject to control by three or less sprinklers supplied by 200 gallons of liquid.

It consists in brief of a "soda and acid" chemical tank or engine of 200 gallons capacity connected to a system of pipes and sprinklers arranged in a similar manner to a standard automatic sprinkler system; an alarm valve; a combined shut-off and check valve; and an expansion chamber located at the top of the riser above the highest sprinkler. The tank is filled with a solution of bicarbonate of soda such as is used in a soda-acid hand extinguisher. The acid charge is located in a dome attached to the tank and so arranged that the acid can be syphoned into the tank when needed. A small suction pipe extends from the acid dome to the expansion chamber at the top of the riser. The piping, down to a check valve in the riser near the tank, is filled with a non-freezing solution of calcium chloride.

The action of the device is as follows: When a fire occurs a sprinkler head opens and the calcium chloride solution is discharged through the open head or heads. This lowers the height of liquid in the main riser and thus forms a partial vacuum in the expansion chamber.

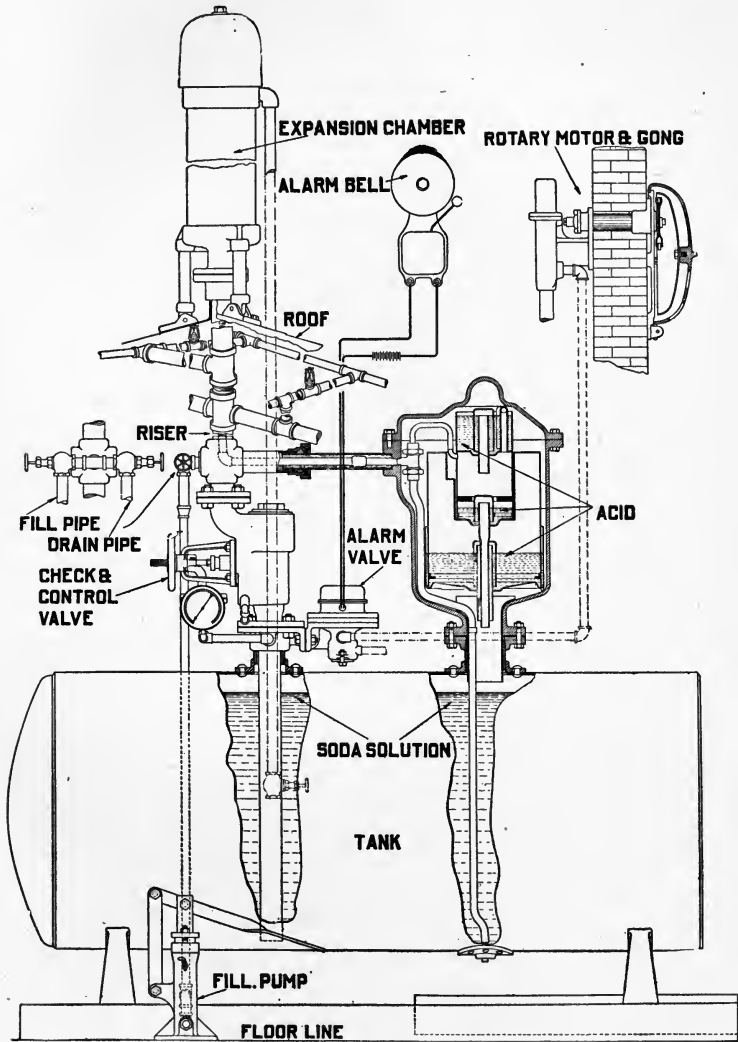

GENERAL VIEW OF SYPHO CHEMICAL SPRINKLER SYSTEM.
(Condensed and not to scale.)

This loss of pressure or partial vacuum is transmitted to the acid dome through the small pipe thus starting the cycles of syphonic action in the acid. The acid then flows into the tank forming carbonic acid gas which soon develops a pressure of about 100 pounds and discharges the contents of the tank through the riser and opened sprinklers.

It is not an automatic sprinkler system but is a new device for automatically extinguishing fires, comprising features of the automatic sprinkler system as well as those of the chemical extinguisher. It is under such a classification that it was approved by the Underwriters' Laboratories.

DETAILS

Description of tank. The tank is cylindrical and made of Allegheny iron uncoated on the inside but painted on the outside with two coats of mineral paint. It is 76 inches long and 30 inches in diameter, which gives a fluid capacity of 200 gallons, and is designed for a working pressure of 130 pounds. There is an opening 5×3 inches for cleaning located in one end provided with a manhole cover bolted on. There is also a one-inch drainage hole in the bottom closed by a threaded cast-iron plug.

The discharge pipe, 2 inches in diameter, enters the top and extends down to the bottom of the tank. There is a dome-shaped casting bolted to the top of the tank which contains the sulphuric acid charge. The tank is kept full of a solution of bicarbonate of soda and water, consisting of 0.6 pounds of bicarbonate of soda to each gallon of water or 120 pounds of soda to each complete charge. The tank is filled to the proper level through the opening caused by the removal of the acid dome.

The tank can be located in any convenient part of the basement or floors above but where temperature will

not fall below 50° F. and never more than 60 feet below the highest sprinkler.

Acid charge. The acid charge is contained in a dome attached to the top of the tank by a flanged joint. The cover of the dome is removable and can be unbolted when the tank is to be examined or recharged.

The acid receptacles are three in number and are supported one above the other in the chamber of the syphon dome. They are made of lead, in three cylindrical parts. The upper receptacle and upper part of the intermediate receptacle constitute one part; the lower part of the intermediate receptacle and the upper part of lower receptacle form the second part; and the lower part of the lower receptacle forms the third part. The upper part telescopes into a recess and is supported by the second part. The second part telescopes into and is supported by the third part, which rests on the bottom of the chamber in the syphon dome.

The upper acid receptacle is open at the top and is filled with sulphuric acid. The intermediate acid receptacle is closed at the top, except for a small vent in the top of a tube extending up through the upper acid receptacle, and is only filled with sufficient acid to form a seal at the bottom, the space above the acid forming an air chamber. The acid in these two receptacles constitutes the primary, or starting, charge. The lower acid receptacle is closed at the top, except for a small vent in the plug closing the opening for filling, and is partly filled by the acid that constitutes the secondary or follow-up charge, the space above the acid in this receptacle also forming an air chamber. The small vent holes into the air chambers of the intermediate and lower acid receptacles serve to equalize pressure difference due to temperature changes and are not large enough to affect the normal operation of the engine.

A syphon of the bell pattern is located in the middle of

each acid receptacle. The long leg of each syphon is made of lead pipe and extends down through the bottom of the receptacle in connection with which it is used. The bell portions are made of an alloy of antimony and lead and are placed in position over the upper ends of the pipe portion.

The upper syphon is started by the suction caused by the lowering of the level of the solution in the expansion chamber at the top of the system, and discharges the acid contained in the upper acid receptacle into the intermediate acid receptacle, which starts the intermediate syphon and discharges the acid from both of these receptacles (constituting the primary charge) down the pipe extending through the middle of the lower acid receptacle and independently into the soda solution in the tank. The lower syphon is started by the expansion of gas in the chamber above the acid in the lower acid receptacle, when the pressure in the tank is lowered and discharges the secondary or follow-up acid charge in the lower acid receptacle independently into the soda solution in the tank, intermittently as required to sustain pressure.

Distribution system. The contents of the tank can be discharged through a system of sprinkler heads and piping similar to that used in the standard automatic sprinkler system except that the sizes of pipes are limited to $\frac{3}{4}$ inch, $1\frac{1}{4}$ inch and 2 inches and that there are no dead ends. The main riser is 2 inches in diameter and extends from the bottom of the tank or engine to near the top of the expansion chamber above the roof. On each floor, $1\frac{1}{4}$ -inch feed pipes connect with the riser and connect with both ends of the $\frac{3}{4}$ -inch tie pipes which are spaced about every 10 feet or less and to which the sprinkler heads are attached. The sprinkler spacing is about the same as in a standard automatic sprinkler system. The piping on each floor is so installed as to

give proper drainage and venting to the entire distributing system. This is done so that the system can be filled with liquid pumped in at the base of the riser, and in so doing all air in the pipes will be driven out through the riser into the expansion chamber and when the system is drawn off all liquid will drain through the draw-off pipe. It is desirable that the runs of $\frac{3}{4}$ -inch pipe be limited to 4 or 5 heads to prevent excessive friction loss.

Sprinkler heads. The piping system and sprinklers are in contact for a greater part of the time with a solution of calcium chloride and may be at times subjected to solutions of bicarbonate of soda and sulphate of soda, the latter being formed when sulphuric acid acts upon bicarbonate of soda. Tests of the Underwriters' Laboratories show that some types of sprinkler heads are likely to leak after being subject to these solutions on account of the chemical action. The Niagara B head was found to be affected the least and to be very satisfactory for the purpose. The Rockwood D heads withstood the calcium chloride solution satisfactorily but showed some leakage under action of the other solution. All other approved types tested showed some leakage after contact for 90 days with these solutions under 90 pounds pressure.

Expansion chamber. This is a somewhat complicated device consisting of three concentric chambers, the outer one, *A*, being 8 inches in diameter by about 5 feet long. It has a $\frac{3}{4}$ -inch overflow pipe, *C*, piped back to where the tank is located. The intermediate or vacuum chamber, *D*, is of tapered form, being 4 inches in diameter at the top and $2\frac{1}{2}$ inches in diameter at the bottom. The top is closed but the bottom is open, terminating about 4 inches above the bottom of the outer chamber. The inner or suction chamber, *F*, is a $1\frac{1}{2}$ -inch pipe, practically a continuation of the 2-inch riser *J* passing up through the building from the tank. The inner chamber communicates with the

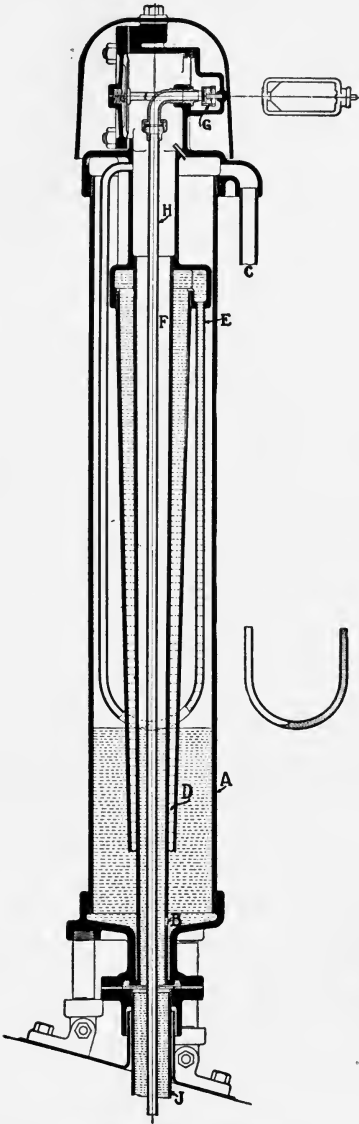

EXPANSION CHAMBER.
(Sectional View.)

outer chamber, *A*, by $\frac{1}{2}$ -inch hole, *B*, located near the base of the device to permit both chambers to fill when the system is charged, and at the top by a brass vent tube having a $\frac{1}{16}$ -inch orifice. The inner chamber, *F*, is also connected to the intermediate chamber, *D*, by a $\frac{3}{8}$ -inch "U" tube, *E*, known as the detector tube whose longer leg connects to the top of the inner chamber, and whose shorter leg connects to the top of the intermediate chamber, which is about 7 inches below.

At the top of the inner chamber, there is a valve, *G*, normally kept open by a spring but closed by a diaphragm when the system has operated. This valve controls the connection between the inner or suction chamber and the $\frac{3}{8}$ -inch tube *H* which passes down inside the riser to the acid chamber and furnishes the means by which the acid syphon in the tank is started.

The expansion chamber is mounted on a suitable plate for erection on the roof above the building, and proper brace rods are provided. Its office is to operate the system when the level of the solution in the sprinkler riser drops rapidly, as in the operation of one or more sprinklers, or if the level falls gradually as in the case of a slight leak. In the latter case the continual lowering of the solution establishes a difference of pressure in the inner and intermediate chambers sufficient to overcome the column of liquid in the detector tube, which destroys the support of the column of liquid in the intermediate chamber, permitting it to fall rapidly and actuate the acid syphon.

Gas check valve. There is a small gas check valve in the top of the expansion chamber to shut off the suction line after the tank has operated and to prevent back pressure from reaching the expansion chamber. This is a rubber-faced valve operated by a diaphragm.

Suction line. This is a small pipe, *H*, extending from the intermediate acid receptacle in the dome through

the riser into the expansion chamber. It is run through the riser to safeguard it against breakage or leaks, for if this pipe should develop a serious leak the system would not operate because the reduction in pressure in the expansion chamber caused by the drop of liquid in the riser would vent itself through the leak and would not start the acid syphon.

A branch, called the sub-suction pipe, extends from the suction pipe in the acid dome down into the chemical engine or tank to a point near the bottom. It provides a means for draining any excess solution from the expansion chamber into the tank. The lower end of this pipe is sealed by the soda solution when the tank is charged.

Shut off and check valve. In the discharge pipe close to the tank is located a combination gate and check valve. The check valve is to prevent the solution of calcium chloride from flowing into the chemical engine. The gate valve is to shut off the supply to the sprinklers when the fire is out. The check valve is of the vertical rising type consisting of a cast-iron disc 4 inches in diameter faced with rubber held in place by a bronze ring. The valve seat is of bronze threaded into a cast-iron body. The check valve is guided by a bronze stem on the under side passing through two guide rings.

There is an automatic drip pipe in the riser just below the check valve arranged to care for any leakage that may get by the check. There is a plug in the casting just over the check which can be removed to clean and examine the valve.

The gate valve consists of an outside screw and yoke type stem passing through a stuffing box and arranged to force the check valve on to its seat when the stem is screwed in. There is a locking mechanism attached to this valve which, by means of a diaphragm, paul and ratchet, prevents the valve from being closed except

when there is pressure in the tank. This is done to prevent the valve from being closed when the system is set in its normal condition, that is with the tank charged and ready for use but not under operating pressure. When the system operates, however, the pressure in the tank and discharge pipe acting on the diaphragm allows this valve to be closed.

Alarm valve. There is an alarm valve attachment consisting of an electric bell and a water motor gong of the same type as those used in a standard sprinkler system. The alarm pipe is connected to the discharge pipe just above the tank and below the check valve. It runs to a casting containing a circuit closer for operating the electric bell and also a diaphragm operating a valve connected to a pipe from a reliable independent water supply. When the system operates and a pressure is created in the tank, this pressure operates the circuit closer and also opens the valve to the independent water supply, thus allowing water from this source to flow to the water motor gong and ring it.

CHARGING

It is planned to ship the solutions of calcium chloride and of bicarbonate of soda to the plant in drums and to have them used only by trained men. After cleaning the tank, the check valve is cleaned and placed on its seat. Then the calcium chloride solution is slowly introduced into the distributing pipes, in which a vacuum has been created through a connection at the base of the riser, until the system is filled.

The gate valve in the end of the overflow pipe is then sealed closed. Great care must be taken in filling the system that all entrapped air is forced out at the top of the system as a considerable amount of air in the pipes would expand when a sprinkler opened, thus retarding the drop in level of the liquid and the operation of the

syphon. The lower end of the discharge pipe in the tank and the ball drip should be carefully examined to make sure that the check valve is tight.

The charge of soda solution is then pumped into the tank to the proper level. Lastly the acid charge of 189 fluid ounces for the lower receptacles and 77 ounces for the upper receptacle is poured in and the acid dome bolted in place.

TESTS AND EXAMINATIONS

The more important tests and examinations of the system are as follows:

1. General condition of piping, sprinklers and tank.
2. Condition of shut-off valve and ball drip.
3. Condition of acid and of soda solution. These can be accurately tested by hydrometers.
4. See that acid vent plugs are in place.
5. Condition of expansion tank and level of solution in same.
6. Test of alarm connections.

INSTALLATION AND MAINTENANCE

The Sypho Chemical Sprinkler Corporation proposes to license responsible sprinkler companies to install and maintain this system. The devices will be rented and not sold. As soon as the work is completed and accepted, the Sypho Chemical Company will assume the responsibility of inspecting the system. This will involve periodic inspection by trained inspectors at which the acid will be examined, the solutions tested for density and a general inspection of the device made. Extra charges of acid and the solutions used should be available at all times so that the device can be recharged without delay.

In case the system operates, the nearest representative of the installing company will be notified by some pre-arranged method and a man will be sent to recharge the

system. Under no conditions should anyone else attempt to recharge the system.

FIELD EXPERIENCE

A few of these systems have been installed during the past year in New England and elsewhere. The field experience, however, has been too limited to allow a fair estimate of the value of the device.

The only fire known to have occurred under this form of protection was in the jewelry store of Thomas Long Company, Boston, April 22, 1918. This is a small six-story brick building completely equipped and with tank on the top floor. A room in the basement about 16 feet square was used as a packing room and contained a quantity of loose excelsior, paper, old boxes and a bale of excelsior. There were seven sprinklers (Niagara B) in the room, one being under a stone stairway leading to an exterior door. Fire started in the waste material early in the afternoon and employees were notified by feeble ringing of electric bell connected to the system. The rotary gong failed and was found afterwards to be clogged. Fire department was called and extinguished remaining blaze with a chemical stream.

Two sprinklers had opened and held the fire but there is a difference of opinion as to whether they entirely extinguished it. The tank was entirely drained. Loss about \$75.

CONCLUSIONS

1. This device is simple in principle though more or less complicated in details. It operates with practically no moving parts and there is but little about it that is liable to get out of order.

2. It is difficult to recharge properly and it is quite essential that all systems be maintained by agents of

the installing company who are thoroughly familiar with the details and who will give it careful supervision.

3. Unless excessively long tie pipes are used such a system should successfully control about 50 per cent of all fires that are likely to occur in risks equipped with it, for the statistics on sprinkler fires covering 20 years show that about 50 per cent of the fires are controlled by 3 sprinklers or less. If limited to risks of light hazard and small size a larger percentage of fires should be controlled. Care should be taken that not over 5 heads are placed on one $\frac{3}{4}$ -inch tie pipe.

4. The protection would seem to be adapted for factories and mercantile risks where high ceilings do not obtain, where flash fires are not liable to occur and where the installation is so made that no undue loss of pressure shall result from pipe friction; and particularly adapted for such properties as country clubs and country homes, where an adequate water supply is not easily obtained.

5. The solution in the pipes is non-freezing and the device is therefore adapted to unheated buildings provided only that the tank is properly protected against frost and not allowed to get too cold.

6. Further field experience is needed to judge of the final merits of the system.

APPENDIX I

Alphabetical List of Automatic Sprinklers

ADAM

Mm. Wauquier et cie, Lille, France.

Upright valve sprinkler resembling the Grinnell glass disc in principle. Orifice a thin metal diaphragm closed by a glass disc. The strut is made up of several pieces and is adjustable. Small toothed deflector.

Not used outside of France so far as known.

ADKINS

Samuel Adkins, St. Louis, Mo.

1-1895. Valve sprinkler. Valve of agate held in place by levers in the form of a triangle.



2-1895. Valve sprinkler. Valve held in place by strut.

Both obsolete. Never used so far as known.

ÆTNA

Ætna Fire Sprinkler Co., Chicago.

Combined with Independent Ætna Sprinkler Co. of Philadelphia in 1918.

Used the Lapham sprinkler at one time.

ALBION

Greenwood & Batley, Ltd., England.

Upright, valve sprinkler. Metal valve disc held in place by toggle joint levers. Very similar to the International Sprinkler. Never used in America so far as known.

Now practically obsolete.

**ALLEN AND REED**

Allen and Reed, Providence, R. I.

1-1906. Upright valve sprinkler with strut. Cast-iron frame.

Never used to any extent.

Rating: *Questionable.*

2-1911. Upright valve sprinkler, almost a duplicate of the Grinnell glass disc head. A few were installed but soon afterwards removed.

Rating: *Questionable.*

3-1912. Similar to No. 2 but with strut split at the base.

Never used so far as known.

Rating: *Questionable.*



ALLEN & REED
2.

ALERT

See *Naylor.*

ALEXANDER

D. A. Alexander Automatic Sprinkler Co., Rochester, N. Y.

A-1918 upright valve sprinkler. Valve held in place by strut. Not yet submitted to the Underwriters' Laboratories.

Note: This company also has a dry valve consisting of two valves on the opposite ends of an arm pivoted in the center.

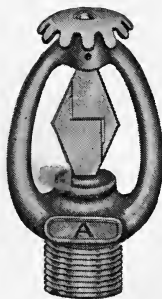

ALEXANDER A.

ALLIS

Allis Fire Extinguisher Company, 198 Milwaukee Street, Milwaukee, Wis.

A-1916. Upright valve sprinkler. Solid valve cap with copper washer held in place by toggle joint levers and link. Link composed of two flat plates containing opposed projections between which a key is inserted.

Combined with Independent-Ætna Sprinkler Co. of Philadelphia, 1918.

Never used so far as known.

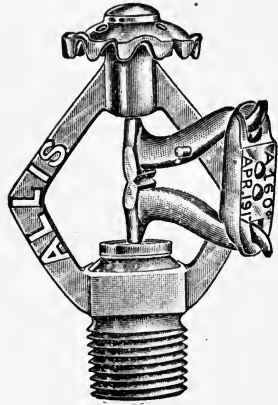

AMERICAN

American Sprinkler Co., Chicago, Ill.

1892. Valve held in place by horizontal arm. Arm held at each end by a soldered joint pinned to an angular projection. Perforated and slotted deflector. Threaded for a $\frac{3}{4}$ -inch fitting.

Never used so far as known.



A. F. M.

A-1918. Designed in the Inspection Department of the Associated Factory Mutual Insurance Companies, Boston. Patents sold to the Fire Protection Securities Co. of Boston. To be manufactured and sold by the Kellogg-Mackay Equipment Co. of Chicago, on a cost plus reasonable profit basis. G. M. Parks Co. of Fitchburg, Mass., will be New England agents.

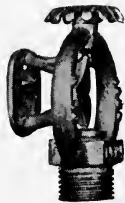

The sprinkler is of the ordinary lever and link pattern of the same general idea as the International head, but the details have not yet been made public. It is expected that the sprinkler will be available for installation about October, 1918.

A dry valve is also being developed by the same interests.

ASSOCIATED

Associated Automatic Sprinkler Co., 2218 Vine St., Philadelphia, Pa.

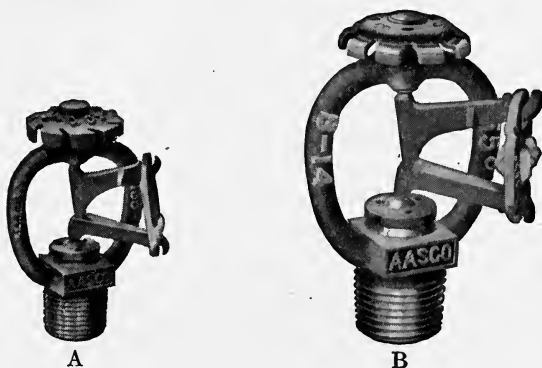

ASSOCIATED SPRINKLER.

A-1913. Practically a duplicate of the International sprinkler except that the frame bulges more at the top and the corrugations in the link are at an angle of 90 degrees.

Approved by the Underwriters' Laboratories, September, 1913. Field experience satisfactory. Replaced by issue B, August, 1914.

Rating: *Satisfactory.*

B-1914. Similar to type A but with a new deflector made of No. 14 B. & S. gauge bronze, containing 9 notches and 3 holes. Upper end of compression screw practically flush with deflector.

Approved by Underwriters' Laboratories, August, 1914. Withdrawn April, 1916; manufacture discon-

tinued. Company combined with Globe Automatic Sprinkler Co. Field experience satisfactory.

Rating: *Satisfactory*.

"AUTOMATIC" SPRINKLER CO. OF AMERICA

Executive Offices, 123 William St., New York.

This company was formed in May, 1911, and was a consolidation of the Manufacturers Automatic Sprinkler Co., the Niagara Fire Extinguisher Co. and the International Automatic Sprinkler Co. The company controls the following approved sprinklers: *Manufacturers, Niagara, International*. Since 1913 this company manufactured the *Lapham B* sprinkler for the *Ætna Fire Sprinkler Co.* of Chicago, but it does not install the device.

See *Manufacturers, Niagara, International*.

BABCOCK

Patented by *E. F. Steck of Chicago*. Assigned to the *Fire Extinguisher Manufacturing Co. of Chicago*.

1900. This was an upright valve sprinkler. Valve was hollow and held in place by a strut somewhat resembling that in the Grinnell glass disc head. Perforated deflector located inside the frame. Underwriters' Laboratories Report in 1902 criticized:

(1) Leaking point, (2) effects of corrosion and loading, (3) releasing device, (4) deflector, (5) disc, (6) structural weakness, (7) distribution, (8) solder in high test pattern.

A few thousand were installed from 1897 to 1904 but field experience was unsatisfactory.

Tests of the Underwriters' Bureau of New England between 1909 and 1912 of clean heads taken from the field; 9 failed out of 18 tested. These heads have now been mostly replaced.

Present rating: *Unreliable*.

See also *Steck*.

Note: There was a previous sprinkler patented in 1897 with a toothed deflector located on outside of frame. This was not used so far as known.



BACH

Patented by *N. S. Bach of Boston.*

1876. A rose sprinkler covered with a cap. The cap was held in place by four hinged levers. The levers were held together by a cord wound around them and then running to the adjacent head. The burning of the cord opened the heads.

Never used so far as known.

BARNES

Charles Barnes of Dayton, Ky., and Cincinnati, O. Some manufactured by *J. I. Covington* of the same city.

A-1879. Perforated bulb head with valve. Valve held in place by spindle which was threaded to a nut, the nut being soldered to the lower side of the casting. Never used so far as known. See page 25.

1-1881. Perforated bulb type. This was a valve sprinkler, the valve being held by a spindle resting against a hinged lever. The lever was held to the frame by a latch of low-fusing solder. Distribution was from a perforated bulb and was therefore poor. Used to a very limited extent. Crude and subject to leakage; easily damaged and clogged. See page 25.

Obsolete.

Present rating: *Unreliable.*



BARNES-1
(Section.)

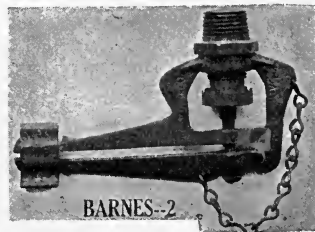

BARNES-2

2-1885. Long side lever type. This was a valve sprinkler, the valve being held in place by a long lever hooked to the frame at one end and attached to a projection on the frame by a link at the other end. Rotating deflector and valve were all one piece. Used to a moderate extent. Crude and easily damaged.

Obsolete.

Present rating: *Unreliable.*

BEECH

Patented by *Handel Beech of Oldham, England*, later of *Monson, Mass.* Bought out by *Dowson & Taylor Co.*

1899. Upright valve sprinkler. Valve was a semi-spherical metal button and was held in place by a five-piece strut with small "sugar tongs" release. Threaded for $\frac{3}{4}$ -inch fitting.



Underwriters' Laboratories Report, 1905, criticized:

1. Susceptibility to corrosion and loading.
2. Lack of sharpness in operating.
3. Possibility of readjustment in the field.
4. Construction of seat.

Never used in this country so far as known.

BIRKETT

1883. Valve sprinkler with large hollow perforated distributor. Valve spindle held in place by horizontal bar soldered across a circular opening at the end of the casting.

Never used so far as known.

BISHOP

John W. Bishop, New Haven, Conn.

Bishop heads were installed by J. F. Gilbert & Co. of New Haven, Conn., as early as 1880. The risks of

A. H. & C. B. Alling, Derby, Conn., and Montgomery Yarn Mills, Windsor Locks, Conn., were equipped about that time. Also the buildings of the Atlanta Exposition. Some Bishop heads were installed by Foskett & Bishop previous to 1882 and later the New Haven Automatic Sprinkler Co. and the New York & New Haven Automatic Sprinkler Co. installed these heads.

A-1879. Pendent, water-joint or "sealed" sprinkler. Slotted rotating distributor. Arrangement for letting out air in sprinkler pipe to prevent disturbance of alarm by momentum of water or water hammer. See page 26.

1-1883. Pendent, water-joint type. Interior slotted distributor. Cap about $\frac{1}{2}$ -inch diameter soldered to outside of head. Direct strain on solder. See page 26.

1 $\frac{1}{2}$ -1883. Similar to No. 1 except that a thimble was soldered to the interior of the outlet instead of a cap on the outside. A slightly more sensitive head. Direct strain on solder. See page 26.

2-1884. Pendent, water-joint head. Thimble soldered to inside of outlet. Deflector with perforated edge



held close to orifice by light spring. Pushed away by water when head opened. $\frac{3}{4}$ -inch fitting. Direct strain on solder. See page 26.

$2\frac{1}{4}$ -1884. Pendent valve sprinkler. Valve spindle held in place by thimble soldered to inside of tube. Deflector with perforated edge held close to orifice. $\frac{3}{4}$ -inch fitting. Direct strain on solder. See page 45.



$2\frac{1}{2}$ -1885. Similar to No. $2\frac{1}{4}$ except frame was all one casting. Threaded for $\frac{3}{4}$ - or $\frac{1}{2}$ -inch fitting.

3-1885. Similar to No. $2\frac{1}{2}$ except for circular piece below deflector. $\frac{1}{2}$ - and $\frac{3}{4}$ -inch fitting. Direct strain on solder. See page 46.

$3\frac{1}{2}$ -1887. Patented by R. W. Miller and assigned to New York & New Haven Automatic Sprinkler Co. of New York. Pendent valve sprinkler. Similar to No. $2\frac{1}{2}$ except that valve stem rested against shoulders on two hinged levers. Levers held together by link.

4-1888. Similar in shape to No. 3 except that there were levers and links as in No. $3\frac{1}{2}$.

The earlier types were subject to breaking open on account of the direct strain on the solder and were slow in action. Later types subject to corrosion. All types crude and easily stuck.

All obsolete.

Present rating: *Very unreliable.*

BISHOP

Joseph Bishop, Meriden, Conn.

1897. Valve sprinkler. Metal valve cap held in place by short toggle-joint levers secured by a solder pin. Large toothed and perforated deflector.

Never used so far as known.

BLAUVELT. See Phenix.

BROWN

Joseph R. Brown, Bridgeport, Conn. Assigned to *Automatic Fire Extinguisher Co. of New York*. Manufactured by *Foskett & Bishop Co. of New Haven, Conn.*, and *Automatic Fire Alarm and Extinguisher Co. of New York*.

1-1881. Pendent valve sprinkler. Interior valve held in place by spindle running through interior guide and attached to deflector. Deflector soldered into conical shaped recess in base of casting. Was used to a considerable extent.

Very slow in operation. Crude and not sensitive. See page 30.

Obsolete.

Rating: *Unreliable*.

Note: There was apparently another and older type similar to No. 1 but of the water seal type without any interior valve.

2-1883. Pendent valve sprinkler. Similar to above except that deflector was not soldered in place but was held by a strut and two hinged levers. Levers soldered together at lower side. See page 30.

Obsolete.

Rating: *Unreliable*.

3-1884. Pendent valve sprinkler with two opposed outlets. Orifices closed by valves held by a single strut bearing on each valve. Probably not much used, if at all.

Obsolete.

Rating: *Unreliable*.



BROWN-1



BROWN-2

BROWN & FOSKETT

J. R. Brown and Wm. A. Foskett of New Haven.

1-1875. Elbow head with perforated distributor. Sealed by soldered disc insulated from the water by a core of non-conducting wax.

Never used so far as known.

2-1875. Elbow valve sprinkler. Valve held in place by spindle bearing against cap soldered to end of casting. Coiled spring to assist in opening the valve. Solder under direct strain. See page 21.

Obsolete.

Rating: *Unreliable.*

BUEL

James Buel, Woburn, Mass.

1885. Pendent valve sprinkler with deflector attached to valve stem. Deflector had raised perforated rim. Valve held in place by three horizontal hooked levers.

Never used so far as known.

BUELL

Charles E. Buell, New Haven, Conn. Afterwards of *Plainfield, N. J.* Installed by *Buell and Thompson, New York, Buell Automatic Alarm and Fire Extinguisher Co., Buell Electric & Hydraulic Manufacturing Co., New York,* and others.

The Buell system included dry valves and alarm valves; also some of the sprinklers had alarm attachments.



1-1873. Pendent, elbow valve sprinkler. Valve held in place by stem bearing against a "sugar tongs" lever. Ends of levers soldered together and insulated from casting by chip of wood. Flat circular deflector. See page 24.

Obsolete.

Present rating: *Unreliable*.



1½-1884. Valve sprinkler with valve held in place by levers attached to fusible nut. Distribution from two arms with holes at upper and lower side opposite each other.

Obsolete.

Rating: *Unreliable*.

2-1884. Pendent valve sprinkler of drop deflector type. Valve held closed by levers. Electric alarm attachment.

Obsolete.

Rating: *Unreliable*.

3-1884. Pendent, double outlet sprinkler of circular form, water feeding lower outlet from both directions. No deflector. Water distributed by two opposing streams striking each other. Both valves were held closed by the same levers, one lever being soldered to a thin projection on the head. See page 46.

Obsolete.

Rating: *Unreliable*

4-1885. Pendent, double outlet sprinkler similar to No. 3 except that frame was semi-circular and water only came in one direction to lower outlet. See page 47.

Obsolete.

Rating: *Unreliable*.

5-1886. Pendent valve sprinkler with fixed smooth deflector. Valve stem extended through deflector and



was held by hooked levers soldered together. Used extensively. See page 47.

Obsolete.

Present rating: *Unreliable*.

6-1892. Similar to above but a shorter head with a toothed deflector. Distribution defective under joisted construction. Used extensively. Recent tests show this head to be unreliable. Most of these heads have now been replaced.

Present rating: *Unreliable*.

7-1896. Upright valve sprinkler. Hollow valve cap held in place by two-piece strut.

Small scalloped deflector.

Never used so far as known.

Note: Mr. Buell patented several other sprinklers between 1905 and 1907 most of which were assigned to the General Fire Extinguisher Co. and were never used so far as known.

BURRITT

Albert M. Burritt, Waterbury, Conn. Made and installed by the *A. Burritt Hardware Co., Waterbury, Conn.*

1-1881. Water-joint sprinkler with perforated rose distributor. A thimble was soldered to the inside of the head. A loose cap covered the distributor to keep out dust. Crude and not sensitive. Direct strain on solder. See page 28.



Obsolete.

Rating: *Unreliable.*

Note: The patent, which was assigned to the A. Burritt Hardware Co., also covered an arrangement by which the thimble could be omitted and the cap soldered on to make the water joint.

2-1882. Similar to No. 1 but with open base; that is, the distributor was set a short distance away from the orifice by metal brackets. Crude and not sensitive. Direct strain on solder. See page 27.

Obsolete.

Rating: *Unreliable.*



3-1883. Sensitive or valve sprinkler. Valve held in place by spindle bearing against a lever which was hooked at one end and soldered to the frame at the other end. When open the water struck the valve

and was thrown back against a slotted deflector. See page 28.

Obsolete.

Present rating: *Unreliable*.

All three types used to some extent.

CATARACT

Patented by *Charles W. Kersteter* in March, 1903.

Manufactured by the *Automatic Sprinkler Equipment Co. of Chicago, Ill.*

A-1906. Upright valve sprinkler with diaphragm orifice. Valve disc seated on raised seat and was held in place by a strut. Large toothed deflector. Criticized by the Underwriters' Laboratories as follows:

1. Adhesion of cap. 2. Unreliability of releasing device. 3. Construction details.

Never used so far as known.

Rating: *Unreliable*.



B-1907. Similar to type A but with a modified form of deflector and strut. Tests showed unreliability of releasing device.

Never used so far as known.

Rating: *Unreliable*.

CLAPP

Joseph Clapp, Evanston, Ill.

Manufactured by the *Clapp Automatic Sprinkler Co. of Chicago, Ill.*

1-1887. Single-arm type. Upright valve sprinkler. Valve held in place by lever attached to frame by small

link. Fixed deflector supported by arm. Used to some extent in this and a slightly modified form. Easily damaged. Faulty distribution. See page 48.

Out of 68 recently tested by the Underwriters' Laboratories 16 per cent failed.

Obsolete.

Present rating: *Unreliable.*



1½-1889. Upright valve sprinkler of modern design. Valve cap held in place by strut consisting of several pieces. Fixed cone-shaped deflector. Never used so far as known.

2-1890. Similar to No. 1½ but with flat three-piece strut and flatter deflector. Cap and deflector criticized by Underwriters' Laboratories. Used to considerable extent. Largely replaced. See page 48.

Present rating: *Doubtful.*

CLARK & COOPER

Patented by *W. L. Cooper, Spigners, Ala., 1903.*

Manufactured by *Globe Cotton Mills, Augusta, Ga.*

1904. Upright valve sprinkler. Valve was of glass or hard rubber and of spherical form. It was held in place by a lever hooked at the lower end and soldered at the upper end. The solder joint was reinforced by solder rivets. Deflector held by an arm. Submitted to

Underwriters' Laboratories and practically all features were criticized. Never used so far as known.

CLAYTON

E. S. Clayton, Newark, N. J.
Independent Fire Extinguisher Co.

1906. Upright valve sprinkler. Diaphragm with raised seat. Metal valve disc held in orifice by strut with a horizontal projection.

Never used so far as known.



COMINS

Frank B. Comins, New Bedford, Mass.

1885. Valve sprinkler with conical shaped valve disc and fixed deflector. Valve held in place by two-piece lever soldered to projection on casting.

Never used so far as known.

CONANT

Hezekiah Conant, Pawtucket, R. I.

1875. Valve sprinkler with perforated rose distributor. Globe type of valve used, the spindle being horizontal and held in place by light combustible cord. Operated by burning of cord. Also knife attachment with handle hanging down for cutting the cord by hand. Installed only at Mr. Conant's thread mill in Pawtucket. But few made. See page 22.

Obsolete.

Present rating: *Very unreliable.*

COOK

See *Kersteter.*

CROWDER

Crowder Bros., St. Louis, Mo.

1903-1908. Eight experimental samples submitted for approval. All were criticized by the Underwriters' Laboratories.

Never used so far as known.

A-1909. Upright valve sprinkler somewhat resembling the International sprinkler except in the construction of the link which consists of two flat plates $\frac{3}{4}$ inch wide with opposed grooves filled with solder.

Rating: *Standard.*

**DALY**

M. J. Daly & Sons, Waterbury, Conn.

1899. Valve sprinkler. Metal valve disc with mica washer held in place by adjusting screw passing through a horizontal lever. One end of lever hooked to inside of frame. The other end held by fusible strut under compression. Loose revolving deflector.

Never used so far as known.

DANIELS

1896. Upright valve sprinkler. Metal valve disc held by strut. Large revolving deflector.

Never used so far as known.

DETROIT

Detroit Sprinkler and Chemical Fire Extinguisher Co., Chicago, Ill.

1903. Upright valve sprinkler. Metal valve disc held by strut similar to that in the Clapp sprinkler. Small slotted deflector attached to the inside of the frame.

Never used so far as known.

DIXON

John H. Dixon, Erie, Pa.

1-1903. Upright, valve sprinkler. Valve and deflector in one piece. Interior spindle held by guide. Undeveloped experimental device submitted to the Underwriters' Laboratories for approval. Practically all features criticized.

Never used so far as known.

2-1904. Altered sample submitted for approval. Practically all features criticized.

Never used so far as known.

DODGE

1904. Upright, valve sprinkler. Valve cap held in place by curved levers, attached to a projection at the top of the frame by a fusible member. Toothed deflector attached to inside of frame.

Never used.

DORAIS

Evan Almvall & Co., New York.

1910. Upright, valve sprinkler. Metal valve disc held in place by levers. End of levers held apart by a compression strut composed of several pieces. Toothed deflector attached to inside of frame.

Never used so far as known.

DOUBLE LOCK

*The Double Lock Automatic Sprinkler Co.,
Chicago, Ill.*

1911. Upright, valve sprinkler. Metal valve disc held by levers. Ends of levers held apart by a compression strut similar to that in Dorais. Criticized by Underwriters' Laboratories in July 1911, as follows:



DOUBLE LOCK.

1. Principles of operation.
2. Reliability of operation.
3. Effects of loading and corrosion.
4. Possibility of premature opening.
5. Inability to withstand ordinary abuse.
6. Distribution.
7. Lack of uniformity of manufacture.
8. Construction details.

Never used so far as known.

DRAPER

1884. Patented by *F. H. Prentiss of Boston.*

1890. Patented by *A. T. Gifford.*

1884. Made by the Draper Co. of Hopedale, Mass.
Interior valve opening against water pressure. Valve

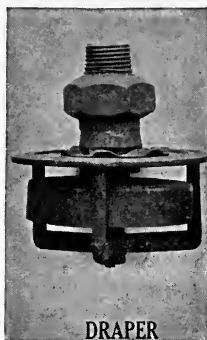

DRAPER

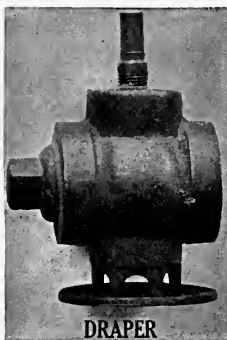

DRAPER

(Differential.)

spindle extended to the upper side of a small closed receptacle with corrugated sides containing volatile hydrocarbon. When the contents expanded from heat the sides were forced apart and the valve was thrown up from its seat. Water distributed from a flat plate with a thin corrugated ring to break up the stream. Used to a limited extent and submitted for approval

in England under the name Draper-Hetherington. Extremely subject to corrosion. See page 34.

Obsolete.

Rating: *Very unreliable.*

1889. "*Differential*" type. Valve sprinkler, the device being in the form of a cross pipe fitting with a valve and orifice at the lower end. Valve held in place by spindle soldered to a sleeve entering vertically from the top of the device. Flat iron deflector supported in front of orifice.

An attempt was also made to use bitumen instead of solder to make the device more sensitive. This was not a success as it was not strong enough. A few were put on the market.

Obsolete.

Rating: *Unreliable.*

ESTY

William Esty, Laconia, N.H. Made by *Esty Sprinkler Co. of Laconia, N.H.* Installed by *H. G. Vogel Co., New York, and others.*



1-1895. *Plain.* Upright, valve sprinkler. Metal valve cap, with oiled paper washer, held in place by duck-bill levers. Flat surfaces soldered together. Revolving deflector perforated and toothed. See page 62.

2-1895. *Corrugated.* Same as No. 1 but with soldered surfaces of duck-bill corrugated.

3-1895. *Cone.* Same as No. 1 but with cone or knob soldered to outer end of duck bill.

4-1895. *Pin.* Same as No. 1 but with solder pin extending through ends of duck bill.



ESTY-3

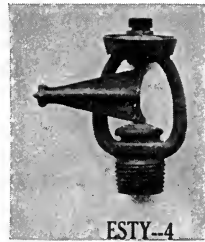

ESTY-4

4½-1895. Same as No. 1 but with bent wire soldered over end of duck bill.

All the above types were experimental and but little used. Liable to open prematurely.

Rating: *Unreliable.*



ESTY-4



ESTY-5

5-1896. *Spring.* Same as No. 1 but with cavity cut between duck bills in which was inserted a steel spring. Cavity filled with wax except in the high test heads. Solder joint strengthened by a wire running under a ledge on the lower duck bill and over a groove in the end of the upper duck bill.

Criticized by the Underwriters' Laboratories as follows:

1. Releasing device. 2. Solder in high degree pattern. 3. Disc. 4. Cap.

Generally approved by local boards. Field experience fairly satisfactory. Not defective except in corrosive locations. Distribution unusually good. See page 62.

Out of 51 recently tested 6 per cent failed.

Rating: *Not standard, generally satisfactory.*

6-1903. Similar to No. 5 but with fixed deflector.

Underwriters' Laboratories Report, 1904, makes similar criticism as for No. 5. Field experience fairly satisfactory. Not standard but not considered defective.

Out of 30 recently tested 2 failed.

Rating: *Not standard, generally satisfactory.*



ESTY-6



ESTY-B

B-1912. Similar to No. 6 except no knob above deflector. Four small knobs cast on edge of valve cap slightly overlapping the valve seat. Slight change in solder joint.

Approved by the Factory Mutual Insurance Companies and by the Underwriters' Laboratories.

Rating: *Standard.*

Note: Mr. Esty took out patents on several other types of heads notably: 1903 valve sprinkler with valve held by two parallel struts about 1 inch apart. 1907 valve disc held by toggle-joint levers and link as in International head. 1909 strut sprinkler with circular frame.

These later types were never used so far as known.

EVANS

Merchant & Evans Co., Philadelphia, Pa.

A-1913. Upright valve sprinkler somewhat resembling the International sprinkler. Two-piece metal valve cap held in place by toggle-joint levers and link. Link composed of two flat plates $\frac{3}{4}$ inch wide containing two opposed angular depressions in which is inserted a key. See page 55.



EVANS.

Approved by the Underwriters' Laboratories in Jan., 1914.

Replaced by issue B in August, 1914. Field experience satisfactory.

Rating: *Satisfactory.*

B-1914. Upright valve sprinkler, very similar to type A, the minor changes being as follows: a one-piece valve made of No. 11 B. & S. gage annealed bronze, diameter of ball depression in valve the same as that in the compression screw, the upper face of the valve slightly crowned, a spring washer used, slight change in pins. It is not readily distinguished from type A except by the markings. Approved by Underwriters' Laboratories, June, 1914. Some of these heads wax coated were found to lack sensitiveness. Replaced by Globe C in 1916. No longer manufactured.



EVANS B.

Rating: *Satisfactory.*

FOWLER

Walter B. Fowler, Lawrence, Mass.

1884. Pendent valve sprinkler with fixed deflector. Valve spindle extended through hole in deflector and was held by two hinged levers. Released by I-shaped piece of solder under tension.

Another type had a loose ring covering a series of radial holes through which the water issued, the water raising the ring slightly.

A few of these sprinklers were installed in eastern Massachusetts. Field experience fairly satisfactory for a few years.

Now obsolete.

Present rating: *Unreliable.*

**F. M.**

See A. F. M.

GARTH

The Garth Co., 26 Craig St., W. Montreal, Canada.



1911. Valve sprinkler with frame resembling the Esty sprinkler. Metal valve disc with mica washer held in place by long duck bill levers overlapping and soldered together at end. Small rotating deflector.

A-1915. Upright valve sprinkler. Diaphragm orifice. Metal valve disc with silver washer held in place by three-piece strut. Fixed toothed deflector. Approved by Associated Factory Mutuals.

Rating: *Probably satisfactory.*

GARRETT

Chas. B. Garrett, Cincinnati, Ohio, formerly of Minneapolis, Minn.

Manufactured and installed by the *Globe Automatic Sprinkler Co., Cincinnati, Ohio.*

1904-1910. Upright valve sprinklers of the strut pattern. Experimental samples submitted to the Underwriters' Laboratories and reported on in December, 1904, May, 1906, June, 1906, August, 1906, February, 1907, July, 1907, and May, 1908.

A few of the 1904 pattern were installed in the State of Washington but nowhere else so far as known.

Rating: *Unreliable.*



GARRETT-GLOBE A

1911. Upright valve sprinkler with strut. Approved in 1911 by the Underwriters' Laboratories.

Withdrawn February, 1914. Manufacture discontinued. Replaced by Globe A. Field experience satisfactory.

Rating: *Satisfactory.*

GLAZIER

J. T. and C. C. Glazier, Indianapolis, Ind. Assigned to Glazier Nozzle & Manufacturing Co.

1905. Small rotating Glazier nozzle with two radial outlets at a slight angle. Perforations in centre of casting between nozzles. Mounted on a casting containing two right angle turns. Interior valve seated vertically and held in place by horizontal stem connected to a hinged lever one end of which was soldered in place.

Never used so far as known.

GLEASON

Elliott P. Gleason, New York.

1888. Pendent, interior valve sprinkler of the Globe valve type. Valve opened against water pressure.

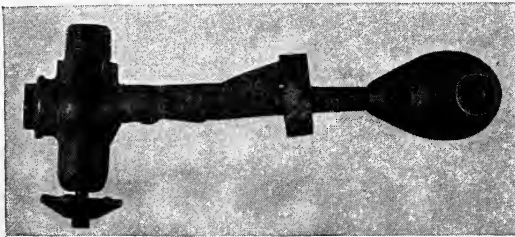

GLEASON.

Rotating deflector. Weighted lever, connected to packed stem extending from valve to outside of casting. The weight was held up by a cord containing a two-piece fusible link. When link melted the weight dropped, opening the valve and starting a train of clockwork which gave an alarm. Not a reliable type of sprinkler.

Never used so far as known.

In another type no cord was used but weight was held by a hinged arm. A link held this arm to a projection on the casting.

GLOBE

Globe Automatic Sprinkler Co., 1610 Reading Road, Cincinnati, O.

A-1914. Upright valve sprinkler similar to Garrett Globe A. Approved by Underwriters' Laboratories. Withdrawn August, 1914. Replaced by issue *B*. Field experience satisfactory.

Rating: *Satisfactory*.

B-1914. Upright valve sprinkler similar to type A except that the lower end of the outer lever is held by a slot stamped out from the inner lever instead of by a separate loop formed of wire. Approved by the Underwriters' Laboratories in 1914.

Withdrawn May, 1916. Manufacture discontinued. Replaced by issue *C*. Field experience satisfactory.

Rating: *Satisfactory*.

Globe Automatic Sprinkler Co., 2019-35 Washington Avenue, Philadelphia, Pa.



GLOBE B SPRINKLER.



GLOBE C.

C (Evans Model) 1916. This is a duplicate of the Evans B sprinkler except for marking which is changed to Globe C. Approved by the Underwriters' Laboratories, 1916.

Rating: *Standard*.

GORTON

English Sprinkler.

Diaphragm sprinkler similar to the Grinnell glass disc head. Approved and used in South Africa.

Not approved in England.

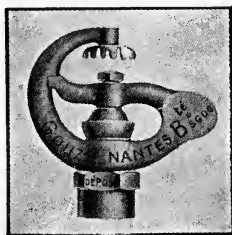
**GOUZÉ**

M. Gouzé, Nantes, France.

Valve sprinkler. Valve disc held by lever hooked at one end and soldered to frame at other end. Toothed deflector supported by an arm.

The Gouzé system includes a water supply consisting of pressure tanks normally under no pressure. Bottles of carbonic acid gas are brought into play when the system operates, thus supplying the necessary pressure.

Used in France but nowhere else so far as known.

GRANGER

A. M. Granger, Boston, afterwards of Buffalo, N. Y.

1-1881. Valve sprinkler of elbow type with rotary turbine distributor. Valve held in place by heavy spring, bearing against the valve and against a nut held in place by fusible solder. Probably not used to any extent. See page 29.

Obsolete.

Present rating: *Unreliable.*

2-1885. Valve sprinkler with rotating deflector attached to valve. Valve held in place by lever somewhat similar to that in the Walworth head. Lever held to projection on casting by a rectangular link. Not much used so far as known.

Obsolete.

Present rating: *Unreliable.*

3-1886. Slight modification of No. 2.

Present rating: *Unreliable.*

GRAY

Frank Gray.

Installed by *Edward Barr Co., New York.*

Manufactured by *Insurers Automatic Sprinkler Co., New York.*

1-About 1884. Pendent valve sprinkler. Valve held in place by stem extending down into hollow tube and resting against thimble soldered into lower end of tube. $\frac{3}{4}$ -inch fitting. Solder under direct stress. See page 49.



GRAY--1



GRAY--1



GRAY--2

2-About 1886. Very similar to No. 1 but with arms of frame at a slight angle.

Both crude and easily stuck. Distribution faulty. A considerable number were installed mostly on the Gray dry system. See page 49.

Obsolete.

Present rating: *Very unreliable.*

3-1899. F. Gray and Charles D. Cox of Chicago patented an upright valve sprinkler. Valve held in place by four-piece strut. Large perforated deflector.

Never used so far as known.

4-1904. Upright valve sprinkler. Perforated deflector on outside of frame. Valve disc held in place by toggle-joint levers and link.

Never used so far as known.

Note: There were several other types of Gray sprinklers varying but little from one another. Also one having a soldered lever for a releasing device.

GREW

English Sprinkler.

1900. Submitted to Underwriters' Laboratories, Chicago, in 1900. Found to be inoperative in test. All features criticized.

A large cylindrical sprinkler.

Never used in this country so far as known.

GRINNELL

Patented by *Frederick Grinnell, Providence, R. I.*

Installed by *Providence Steam & Gas Pipe Co.* up to 1893, after which time by the *General Fire Extinguisher Co.*

1-1881. Pendent valve sprinkler. Valve and deflector all one piece. Valve disc seated on raised ring $\frac{1}{8}$ inch wide in a thin metal diaphragm. Diameter of outlet $\frac{1}{8}$ inch. Stiff plate under diaphragm. Valve held in place by yoke and lever, the yoke being hooked under a notch in the frame and the lever being hooked under a similar notch on the other side. Lever soldered to frame with no reinforcing key. Later the end of the lever was bent over the frame to give greater strength. Deflector had 20 teeth or lobes.

A-1882. Same as No. 1, except a key was used to strengthen solder joint. Deflector had 24 teeth.

In 1883 orifice was enlarged to $\frac{1}{2}$ inch. Valve disc of lead. Seat ring $\frac{1}{8}$ inch wide.

B-1884. Same as *A*, except seat ring was $\frac{3}{32}$ inch wide. Valve disc of tin.

C-1886. Same as *B*, except seat ring was $\frac{1}{32}$ inch wide. In December, 1886, upright heads of this type with perforations in the deflector were first made.



D-1888. Similar to *C*, except babbitt metal was used for the valve disc and seat ring was $\frac{3}{64}$ inch wide. Recess in deflector for the valve disc was $\frac{5}{8}$ inch in diameter while in the older types it was $\frac{7}{8}$ inch. Upright heads of this type were also made, there being holes in the deflector.

About 1895 the issue *C* type was found to be defective as the narrow seat ring caused indentation of the valve disc and sticking of the valve. About ten years later the *A* and *B* types were rated as unreliable on account of sticking at the seat and sticking of the levers. A few years later the issue *D* type was quite generally condemned for the same reason, so that today all these heads having given good service for twenty years or more are considered defective. Nearly all have now been replaced. A few have opened prematurely on account of weakness of solder joint. See page 39.

Present rating of all Grinnell metal disc sprinklers:
Unreliable.

Glass Disc, 1890. Upright valve sprinkler. Heavy diaphragm with $\frac{1}{2}$ -inch orifice. Valve of glass and semi-spherical in shape. Releasing device in the form of a three-piece strut.

In the earliest heads the strut was narrow and with parallel sides. Later it was widened and made bulging in the middle. Key slightly changed in 1893.

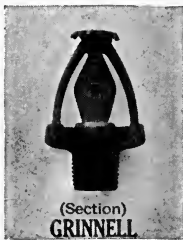

(Section)
GRINNELL
GLASS DISC.



GRINNELL
IMPROVED.

In 1897 the material of the "hook" in the strut was changed from German silver to bronze and it was made thicker. This was done on account of some breaking and cracking at this point.

Some trouble was also caused by cracking of the glass disc. After 1896 annealed glass (with a bubble) was used which obviated all trouble. After 1894 metal discs were used in high test heads. Field experience satisfactory except in some of the earlier heads. See page 64.

Rating: *Generally reliable.*

Improved, 1903. Similar to previous type but with heavier deflector containing fewer teeth. Approved by the Underwriters' Laboratories in 1903.

Rating: *Standard.*

Picker Trunk, 1903. Provided with longer base casting and smooth deflector for use in picker trunks and conveyors.

Rating: *Standard.*

Glass Cover, 1912. Releasing device protected by a glass cover fitting into a groove filled with non-drying compound, in the body of the casting. For use in corrosive locations. See page 79.

Rating: *Standard.*

GRINNELL

Canadian General Fire Extinguisher Co., 1200 Dundas St., Toronto, Ontario.

Improved, 1903. A duplicate of the sprinkler made by the American Company with letters CAN. on lower part of frame. Approved by Underwriters' Laboratories.

Rating: *Standard.*

GUNN

John Gunn, Webster, Mass.

1885. Pendent valve sprinkler. Drop deflector type. Valve held in place by hinged levers fastened to projection on casting by a fusible link. Deep cup-shaped deflector.

Used to a limited extent locally.

Obsolete.

Present rating: *Unreliable.*



HARKNESS

Patented by *Wm. Harkness, New York.* Installed by *Harkness Fire Extinguisher Co., New York.* Some systems installed with non-freezing solution normally in the pipes.

A-1885. Pendent valve sprinkler of drop deflector type. Deflector had teeth on the edge and soft metal valve disc in the middle. Valve held in place by cross-

shaped strut, the two horizontal arms being soldered to the frame. A small spring tended to throw out the vertical members, when solder fused. Threaded for $\frac{3}{4}$ -inch fitting. Never used so far as known.

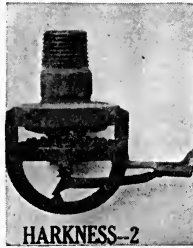

1-1887. Similar to above but strut held in place by horizontal lever soldered to a projection on the frame. Threaded for $\frac{3}{4}$ -inch fitting. See page 51.

Present rating: *Unreliable*.

2-1889. "L" joint. Smaller head than No. 1 threaded for $\frac{1}{2}$ -inch fitting. Valve covered a hole in circular diaphragm. Valve stem held by bent horizontal lever and small ball. Lever soldered to projection on frame by L-shaped joint. Large fixed deflector with teeth on the edge.

Present rating: *Unreliable*.

3-1890. Same as No. 2 but with rectangular-shaped solder joint.

Present rating: *Unreliable*.

4-1894. Same as No. 2 with V-shaped joint.

Present rating: *Unreliable*.

Field experience of all types fairly satisfactory. Now practically obsolete.



HARRIS

Patented by *A. S. Harris, Chelsea, Mass.*

1-1881. Water-joint type. Cap soldered over perforated distributor.

Never used so far as known.

2-1882. Pendent valve sprinkler. Hollow valve stem extended to bottom of casting and was soldered to two small strips of metal projecting downward. Water distributed through perforations protected by a loose cap. Never used so far as known. See page 31.

3-1883. Pendent valve sprinkler with toothed deflector. Valve stem extended through hollow tube and was held by a thimble soldered into end of tube. Direct strain on solder joint. See page 31.

Some of these heads were installed by the Walworth Manufacturing Co. previous to the manufacture of the Walworth head.

Obsolete.

Present rating: *Unreliable.*

**HARRISON**

Stuart Harrison, England.

1864. Pendent valve sprinkler with rose distributor. Soft rubber cup-shaped valve held in place by stem

bearing against a solder joint. Solder insulated from main casting by a projection of hard wood.

Never used so far as known but a remarkably good sprinkler for that date. See page 14.

HEATH

Ozro C. Heath, Providence, R. I.

1-1881. Pendent, water-joint type with revolving distributor. Cap fastened to top of head by means of fusible pins.

2-1882. Pendent valve sprinkler with fixed toothed deflector. Valve held in place by stem threaded to a nut, the latter being soldered to a hole in the frame.

3-1882. Pendent valve sprinkler with similar distributor. Cap was screwed onto a collar, the collar being attached to the head by low-fusing solder. This enabled the cap to be unscrewed from the collar in order to examine the interior of the head.

None of these heads were ever used so far as known.

HIBBARD

Geo. E. Hibbard, Chicago, Ill.

Manufactured by *Geo. E. Hibbard, Chicago; Geo. E. Hibbard & Co., Chicago; American Fire Extinguisher Co., Chicago; National Fire Extinguisher Co., Kansas City; Niagara Fire Extinguisher Co., Akron, Ohio.*

Installed by *Mallers, Allen and Frazier, Chicago; Francis Bros. and Jellett, Philadelphia; Macauley Bros., Grand Rapids, Mich.; W. H. Littlefield, San Francisco; Bowles and Warwick, Richmond, Va.; and W. T. Montgomery, Boston.*

1-1893. Upright valve sprinkler. Valve held in place by two hooked levers bearing on edge of valve cap and extending around edge of deflector to top of sprink-

ler. Levers held together by a two-piece fusible link either straight or corrugated. Fixed conical-shaped deflector. First installed in vicinity of Cincinnati but these have probably all been replaced. See page 49.

Obsolete.

Rating: *Unreliable.*

2-1894. Upright valve sprinkler. Hollow valve button held in place by short levers, almost on dead center, and two-piece straight link. Hexagonal wrench head. Lower lever had an arched lower bearing. Two-piece fusible link. Seriously affected by corrosion.

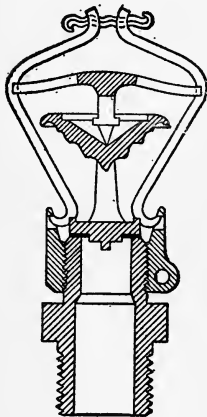

HIBBARD 1.
(Section.)

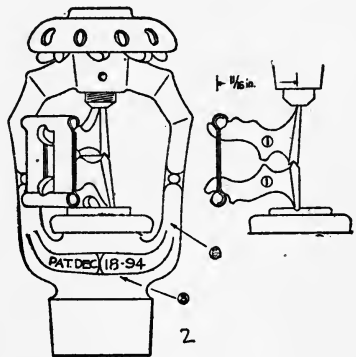

HIBBARD 2.

Structurally weak. Not approved, but a good many in use. Field experience only fair. Age limit about reached. Tests should be made to determine reliability.

Out of 97 recently tested by the Underwriters' Laboratories 29 per cent failed, partly due to levers being on dead center. See page 49.

Rating: *Uncertain.*

3-1897. Same as No. 2 except for longer levers, square wrench head, and heavier frame. Seriously

affected by corrosion and loading. Paper discs in some samples. Caps and discs liable to adhere to seats. Field experience fairly satisfactory. Tests should be made on heads from each equipment to determine reliability.

Out of 193 recently tested by the Underwriters' Laboratories 55 per cent failed, partly due to levers on dead center.

Rating: *Unreliable*.

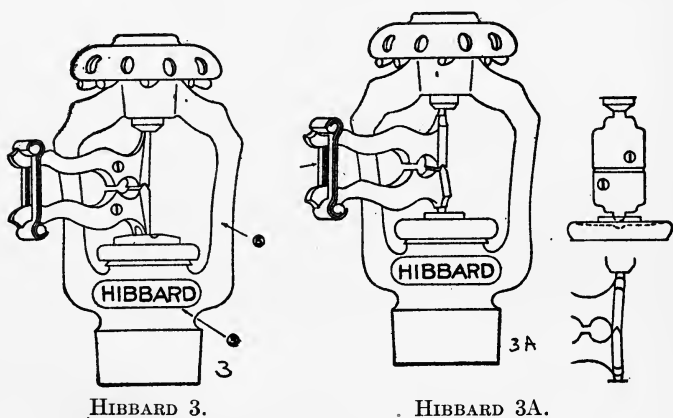

HIBBARD 3.

HIBBARD 3A.

3A-1898. Same as No. 3 except for pivoted lower bearing on lower lever and temperature and date marks usually found on fusible link. Same defects as in No. 3. Soft white metal gasket under valve. This is liable to stick to seat and cut down the discharge about 20 per cent.

Out of 599 recently tested by the Underwriters' Laboratories 32 per cent failed from adhesion at seat, etc.

Rating: *Unreliable*.

4-1901. Same as No. 3 A except for cross piece in fusible link and straight arm levers. Manufactured by

Niagara Fire Extinguisher Co. only and used mostly in the West. Especially subject to corrosion.

Out of 294 recently tested by the Underwriters' Laboratories 34 per cent failed.

Rating: *Unreliable.*

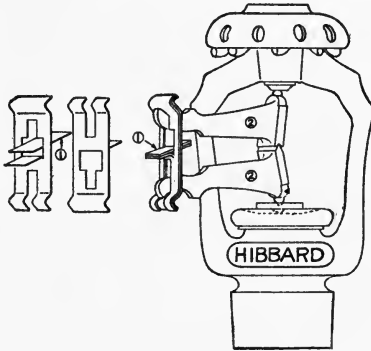

HIBBARD 4.

5-1909. Similar to Niagara-Hibbard *B* except that "Nia-Hib" on wrench head was changed to "Hibbard." Manufactured by Geo. E. Hibbard & Co., Chicago. Not approved.

Rating: *Uncertain.*

I-1911. Upright valve sprinkler, very similar to Niagara Hibbard *B* except for fins on lower ends of arms of casting to give means for distinguishing the head. Manufactured by Geo. E. Hibbard & Co., Chicago. Approved by Underwriters' Laboratories, April, 1911. Withdrawn Oct., 1912. Manufacture discontinued. Used principally in Middle West.

Rating: *Satisfactory.*

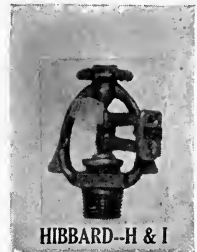

HILL

John Hill, Columbus, Ga.

Manufactured by *John Hill* and by *Hill Automatic Sprinkler Co. of Columbus, Ga.* Later by *Neracher & Hill Sprinkler Co., Warren, Ohio,* and *General Fire Extinguisher Co.*

1890. Pendent valve sprinkler. Oscillating deflector. Has restricted discharge and is somewhat subject to leakage owing to spreading of solder joint. Not standard. Field experience generally satisfactory. Has now about reached its age limit and recent tests show frequent failures.

Out of 184 heads of the light pattern recently tested 20 per cent failed. See page 48.

Present rating: *Unreliable.*

Note: This head was first patented in 1885 and was slightly modified in patents taken out in 1887, 1890 and 1892. Several types were made varying but slightly from one another.

Mr. Hill combined with William Neracher in 1890 and the business was moved from Atlanta, Ga., to Warren, Ohio. A few Hill sprinklers were made at the latter plant. The company sold out to the General Fire Extinguisher Co. in 1892.

**HOFFMAN**

Hoffman Sprinkler Co., Ltd., Manchester, England.

Upright valve sprinkler with diaphragm. Very similar to Grinnell glass disc, except that jet is used instead of glass for the valve disc. Approved and used extensively in England. Agencies in Belgium, France, Germany, Norway and India.



HOLLAND

Made by the *Holland Automatic Sprinkler Company of New York.*

1914. Upright valve sprinkler with rectangular strut composed of several levers soldered together.

Criticized by the Underwriters' Laboratories in November, 1914, as follows:

1. Design of parts. 2. Reliability of operating. 3. Deterioration from corrosion and loading. 4. Sensitiveness. 5. Distribution. 6. Possibility of premature opening. 7. Inability to withstand ordinary abuse. 8. Lack of uniformity in manufacture. 9. Construction details.

Never used so far as known.



HOLLAND.

HORACK

Chas. L. Horack, Brooklyn, N. Y.

Mr. Horack took out several patents between 1882 and 1885 for sprinklers of various types.

None ever used so far as known.

HOXIE

Edmund Hoxie, Everett, Mass.

1891. Pendent valve sprinkler, the valve being of glass and held in place by two large levers soldered together at two points.

Deflector was a flat plate supported about half an inch in front of orifice by five metal bars. Never used so far as known.

IDEAL

Made by *Ideal Automatic Fire Extinguisher Co., Philadelphia, Pa.*

1912. Upright valve sprinkler with diaphragm. Metal disc closed outlet in diaphragm and was held in place by strut. Experimental sample submitted to Underwriters' Laboratories for approval. Features criticized:

1. Halt or hesitation in normal operation. 2. Deterioration resulting from corrosion or loading. 3. Possibility of premature operation under sustained service pressures. 4. Inability to withstand ordinary abuse. 5. Lack of uniformity in manufacturing. 6. Materials employed. 7. Construction details.

Never used so far as known.

Feb., 1913. Experimental sample similar to No. 1, but with different deflector and strut. Features criticized all but 1 and 4 of the above. Also normal operation of hard and extra hard degree rating sprinklers.

A-1914. Similar to previous type but with key on releasing device extending around edges of strut.

Not used to any extent so far as known.



IDEAL A.

INDEPENDENT

Independent Sprinkler Co., Philadelphia.

Independent Aetna Sprinkler Co., 2323 No. Eleventh St., Philadelphia.

A-1916. Upright valve sprinkler of the lever and link type. A phosphor bronze cap with copper washer closes the orifice and is held in place by two bronze levers. The levers are held by a fusible link consisting of three bronze plates, the two outer ones having a semi-spherical depression and the inner one having a round hole for the reception of a ball key $\frac{3}{8}$ of an inch in diameter. Approved by the Underwriters' Laboratories, 1916, and by the Associated Factory Mutual Fire Insurance Companies.

Rating: *Standard.*



INDEPENDENT SPRINKLER.

INTERNATIONAL

Manufactured and installed by the *International Sprinkler Co. of Philadelphia*. Also installed by several licensees in this country and by the *Sprinkler Company, Ltd.*, abroad. Head office of latter company in London. Branch offices in *Amsterdam, Brussels, Milan, Calcutta, Shanghai, Mexico, South Africa, North China, Yokohama* and other places.

The International Sprinkler Co. was founded in 1899, succeeding the Universal Sprinkler Co. and at first installed the Universal Sprinkler. See page 52.

1-1900. Patented by J. C. Scott.

Upright valve sprinkler similar to the Universal No. 2. Link $\frac{1}{2}$ inch wide. Cast metal valve disc. Field experience fairly satisfactory.



INTERNATIONAL-1



INTERNATIONAL-B

Criticized by the Underwriters' Laboratories in 1902: (1) Releasing device, (2) cap, (3) solder, (4) construction details.

Not approved.

Rating: *Uncertain*.

A-1902. Patented by Powell Evans.

Similar to No. 1 except link was made of bronze instead of brass and projections were placed on frame where link would touch it.

Approved, 1902, by Underwriters' Laboratories.

Some trouble experienced from those made in 1902-1904, by premature opening due to cold flow of solder in link. A large number were replaced.

Present rating: *Satisfactory except danger of premature opening*.

A-2 1905. Same as *A* but link made wider ($\frac{1}{3}\frac{1}{2}$ inch). See page 53. Replaced by *B* in 1906.

Rating: *Satisfactory*.

B-1906. Same as *A-2* except slight changes in marking.

Rating: *Standard*.

Note: Special deflectors are also made for aisle lines in car barns, one to distribute in two directions to go between cars, and one to distribute in one direction to go along walls. This company was bought out by the "Automatic" Sprinkler Co. of America in 1911.

JAHN

F. G. Jahn, New York. Made by *Standard Equipment Co., New York.*

1891. Pendent, solid head sprinkler. There was no valve in this sprinkler but a groove was cut in the solid casting at the point where a valve would ordinarily be introduced. There was a heavy lever hinged at one end and attached to the piping by means of a fusible link. When the weight dropped, the lever forcibly broke open the head at the groove. Fixed toothed deflector. Never used so far as known.



1891. Upright valve sprinkler. Porcelain valve cap held in place by four-piece strut, two members of which extended horizontally. Toothed deflector. Not used to any extent so far as known.

Obsolete.

Present rating: *Unreliable*.

JORDAN

Wm. S. Jordan, Worcester. Assigned to *Braman, Dow & Co., of Boston.*

1885. Pendent valve sprinkler, drop deflector type. A large hollow casting contained interior guide for valve which was held against seat by a series of hinged levers bearing against adjustable spindle. Levers tripped by the melting of a short bar of solder under tension. Never used so far as known.



KANE

Patented by *John and William Kane of Philadelphia.*
 Installed by *Wm. Kane Fire Extinguisher Co.; Universal Automatic Sprinkler Co. and John Kane Fire Extinguisher Co.*

W. KANE

1-1881. Pendent valve sprinkler. Valve held in place by a yoke hooked to a projection at one side of the head and soldered to a projection on the other side. Loose cap covered the lower end when the head was closed.

Obsolete.

Present rating: *Unreliable.*

1½-1881. Similar to No. 1 except that there was an arm extending from one side of the head. The yoke was hooked at one end as in No. 1, but at the other end it hooked over a lever which passed through the arm and was soldered to a projection at end of the arm.

Obsolete.

Present rating: *Unreliable.*



W. KANE-1



W. KANE-2

2-1882 Eclipse. Pendent valve sprinkler of globe valve type. Horizontal valve held in place by a complicated system of levers. Loose cap over lower end. See page 33.

Obsolete.

Present rating: *Unreliable.*

3-1888 Bulb Root. Pendent valve sprinkler. Interior valve held in place by two levers. One lever held to projection on casting by two-piece link.

Nearly obsolete.

Present rating: *Unreliable.*



4-1892 Perfection. Pendent valve sprinkler of drop deflector type. Valve held by levers and link similar to those in No. 3.

Out of 28 recently tested by the Underwriters' Laboratories 7 per cent failed.

Nearly obsolete.

Present rating: *Doubtful.*

Note: In 1893 the William Kane Fire Extinguisher Co. sold out to the General Fire Extinguisher Co. and the No. 4 Perfection head was made at the Warren, Ohio, shop of that company for some months.

J. KANE

Made by *Universal Automatic Sprinkler Co.*

1-1892 Universal. Pendent valve sprinkler. Similar to Wm. Kane No. 4, but with fixed toothed deflector.

Out of 6 recently tested by the Underwriters' Laboratories 33 per cent failed.

Nearly obsolete.

Present rating: *Doubtful.*

2-1892 **Universal.** Frame similar to No. 1. Drop deflector similar to Wm. Kane No. 4.



J. KANE-1



J. KANE-2

Out of 139 recently tested by the Underwriters' Laboratories 16 per cent failed from adhesion at seat, etc.

Present rating: *Doubtful.*

2½-1892. Similar to No. 2 with fixed toothed deflector.

Present rating: *Doubtful.*

3-1900. Made by *Niagara Sprinkler Co.* and later by *John Kane Automatic Fire Extinguisher Co.*

Upright valve sprinkler. Valve cap held in place by toggle-joint levers and link. Liable to leakage. Field experience otherwise fairly satisfactory.

Present rating: *Uncertain.*

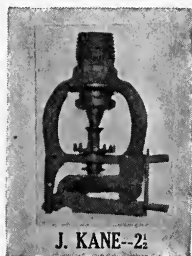

J. KANE-2½



J. KANE-3

4-1902. Upright valve sprinkler. Similar to No. 3 but with levers farther apart. Liable to leakage. Field experience otherwise fairly satisfactory.

Out of 74 recently tested by the Underwriters' Laboratories 5 per cent failed.

Present rating: *Uncertain*.

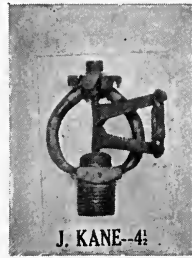

4½-1902. Similar to No. 4 but with longer levers.

Present rating: *Uncertain*.

Note: The J. Kane Automatic Fire Extinguisher Co. sold out to the International Sprinkler Co. in June, 1902, and the latter company manufactured a few J. Kane No. 4 heads until Nov., 1902.

KERSTETER

Chas. W. Kersteter, Chicago, Ill.

A-1888. Single arm type. Valve sprinkler with valve held by a horizontal lever hooked at one end, the other end being hooked to a vertical lever soldered at the upper end to the frame. Deflector supported by a single arm. But few installed.

Practically obsolete.

Present rating: *Unreliable*.

1-1889. Upright valve sprinkler. Valve held in place by two levers hooked at lower end to frame and held together at upper end by a fusible link spanning the head. Perforated toothed deflector. See page 55.

Practically obsolete.

Present rating: *Unreliable*.

2-1893. Upright valve sprinkler. Valve held in place by strut. Crude in workmanship and lacking in sensitiveness.

Present rating: *Unreliable*.

3-1898. Manufactured by *Niagara Fire Extinguisher Co., Akron, Ohio*. Upright valve sprinkler similar to No. 2, but somewhat larger. Subject to crawling and leaking. About 30,000 made. Many replaced by manufacturers. Nearly obsolete. Not made after 1899.

Present rating: *Unreliable*.



KERSTETER--1



KERSTETER--2



KERSTETER--3

4-1897. Upright valve sprinkler, patented by E. M. Cook of Indianapolis. Assigned to Charles W. Kersteter. Valve held by three-piece strut.

Never used so far as known.

5-1898. Similar to No. 3 but with four-piece strut.

LACONIA

See *Vogel*.

LANGFORD

Wm. S. Langford, Baltimore, Md.

1898. Upright valve sprinkler. Valve cap held by strut. Never used so far as known.

LAPHAM

Valentine Lapham, Chicago. Made by *Lapham Automatic Fire Extinguisher Co., St. Louis, Mo.* Later types by *Johnson-Rowe-Paige Co., Omaha, Neb.*; *McCrum-Howell Co., Chicago*; and *Ohio Automatic Sprinkler Co., Youngstown, Ohio*.

1-1890. Upright valve sprinkler with valve cap held in place by three-piece strut of angular shape. Fixed perforated deflector.

Rating: *Unreliable.*

2-1894. Upright valve sprinkler.

Rating: *Unreliable.*

3-1897. Modification of No. 2. Valve cap extended over edge of valve seat with spring underneath.

Rating: *Unreliable.*

4-1902. Upright valve sprinkler. Toggle-joint levers. Experimental sample submitted to Underwriters' Laboratories. Criticized as follows:

1. Releasing device. 2. Effects of corrosion and loading. 3. Solder in high degree pattern. 4. Marking. 5. Distribution. 6. Structural weakness.

Never on the market so far as known.

Rating: *Unreliable.*

A-1910. Upright valve sprinkler similar to No. 4 but with toothed deflector, flatter frame and heavier link. Made by Johnson-Rowe-Paige Co. Submitted to the Underwriters' Laboratories and criticized as follows:

1. Defects in soldering. 2. High and variable leakage point. 3. Inaccuracy in construction. 4. Distribution. 5. Marking. 6. Coloring.

A few of these heads were used in the Middle West.

Out of 33 recently tested 3 per cent failed.

Rating: *Questionable.*

B-1911. Slight modification of A, but much the same in appearance. Approved by the Underwriters' Laboratories. Made by Ohio Automatic Sprinkler Co.

Rating: *Standard.*



LYNDE

Jas. H. Lynde, Manchester, England.

1-1887. Pendent valve sprinkler with interior toothed deflector which dropped when head opened.

Never used in this country so far as known.

2-1893. Pendent valve sprinkler similar to No. 1. Valve held in place by levers attached to a projection in frame by a two-piece rivet-shaped link. Never used in this country so far as known.

MACDANIEL

Valve sprinkler. Large deflector attached to valve disc. Held by strut with spring to throw it off center.

Never used so far as known.

MACKEY

John C. Mackey, Syracuse, N. Y. Installed by *Manufacturers Automatic Sprinkler Co.*

1-1883. Pendent valve sprinkler. Conical shaped valve disc held in place by short strut bearing against brass wire levers. Levers held by two-piece curved link. Fixed deflector. Threaded for $\frac{3}{4}$ -inch fitting. See page 36.

Now obsolete.

Present rating: *Unreliable.*



MACKEY-1



MACKEY-2



MACKEY-3



MACKEY-4

2-1885. Pendent valve sprinkler. Interior valve at top of hollow casting. Stem $\frac{5}{16}$ -inch diameter passed

through $\frac{3}{16}$ -inch hole in casting and was held by lever bar hooked at one end and soldered at other end. Fixed deflector. Threaded for $\frac{3}{4}$ -inch fitting. Water way obstructed. See page 56.

Now obsolete.

Present rating: *Unreliable*.

3-1887. Similar to No. 1 but shorter and with valve stem held by two-piece lever, hooked at one end and held at other end by U-shaped piece of brass soldered around a projection which extended through a slot in lever.

Now obsolete.

Present rating: *Unreliable*.

4-1888. Patented by M. C. Pierce in 1891. Assigned to Manufacturers Automatic Sprinkler Co.

Interior valve sprinkler somewhat similar to No. 3 but longer and with toothed deflector. Valve of copper composition or white metal. Deflector $\frac{3}{8}$ inch from frame. See page 56.

Practically obsolete.

Present rating: *Unreliable*.

Note: There was also an upright sprinkler made by Baker, Smith & Co., New York, about 1883, while Mr. Mackey was with them, that greatly resembled the Mackey head.



MANUFACTURERS-1



MANUFACTURERS-2

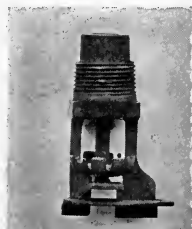

MANUFACTURERS-3

MANUFACTURERS

Made by *Manufacturers Automatic Sprinkler Co., Syracuse, N. Y.* These succeeded the Mackey heads.

Some patents were in the name of C. W. Silver. This company was succeeded by the "Automatic" Sprinkler Co. of America in 1911.

1-1892. Pendent valve sprinkler. Very similar to Mackey No. 4, except that deflector was further from frame ($\frac{1}{8}$ inch). Valve of metal, agate or glass. Head was marked "Non Corrosive." Made for $\frac{3}{4}$ -inch fitting. See page 56.

Out of 14 recently tested 64 per cent failed.

Nearly obsolete.

Present rating: *Unreliable*.

2-1895. Pendent valve sprinkler. Very similar to No. 1 but with an elongated boss at end of threaded portion. Threaded portion $\frac{3}{4}$ inch in diameter.

Out of 30 recently tested 23 per cent failed.

Nearly obsolete.

Present rating: *Unreliable*.

3-1896. Pendent valve sprinkler. Similar to No. 2 but longer and with a smaller deflector. Elongated boss as in No. 2.

Out of 12 recently tested 67 per cent failed.

Practically obsolete.

Present rating: *Unreliable*.

4-1893. Long lever type. Upright valve sprinkler of toggle-joint type. Valve of porcelain held in place by two long levers. A double T-shaped link fitted into slots at end of levers. See page 37. Later issues had spiral spring under porcelain valve. See page 57.

Field experience not satisfactory. Extremely subject to failure by corrosion and sticking of link. But few now in use.

The Underwriters' Laboratories have tested 25 heads of this type which averaged 14 years in service and 40 per cent failed.

Rating: *Unreliable*.

A-1895. Upright valve sprinkler. Similar to No. 4 but with shorter levers. Spring under valve. The link



4 OR LONG LEVER.



as in No. 4 was composed of a T-shaped piece with another piece of similar shape wrapped horizontally around the inner portion. This form of link has been found defective under continued strain and especially if subject to corrosion.

Criticized by Underwriters' Laboratories in 1902 as follows:

1. Releasing device. 2. Solder in high degree patterns. 3. Construction details.

Tests by the Underwriters' Laboratories on 555 samples showed 27 per cent failures.

Present rating: *Unreliable*.

B-1903. Upright valve sprinkler. Similar to A but with small boss projecting above center of deflector. Link of similar shape but with the outer part wrapped over the top of the inner portion. Valve cap rather close to frame so that corrosion at that point might cause trouble. This head has had a fairly satisfactory field experience, but should be carefully watched where subject to any corrosion or loading. Occasional tests desirable.

Out of 225 recently tested by the Underwriters' Laboratories 6 per cent failed.

Present rating: *Fairly reliable.*

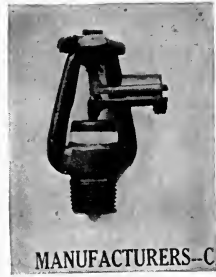

C-1907. Upright valve sprinkler. Similar to *B* but with bosses at end of lower lever so that link cannot be slipped off. Approved by Underwriters' Laboratories, 1907.

Rating: *Standard.*

Underwriters' Laboratories Caution, 1909.

"Last re-examination Feb. 1909 indicates defects in construction not present in samples formerly tested and which render the latest output of these devices unduly susceptible to the influences of corrosion."

These defects in construction were afterwards remedied and the head was approved unconditionally.

MARTIN

H. W. Martin, Ilion, N. Y.

1905. Upright valve sprinkler. Valve of glass held by strut. Toothed deflector somewhat resembling the Grinnell sprinkler. Several variations.

Never used so far as known.

MASCOT

Wm. Shaffer.

1887. Interior valve sprinkler of elbow type. Valve held in place by pivoted levers. Operated by expansion of wax in closed receptacle. Levers were pushed off center by small piston actuated by expanding wax. Used but little if any. See page 43.

Obsolete.

Rating: *Very unreliable.*

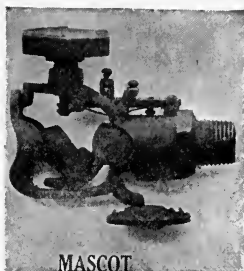
**MAYALL**

W. Mayall & T. Thomasson, Mossley, England.

1891. Valve sprinkler. Valve and deflector in one piece. Valve held by L-shaped lever soldered at lower end to frame. Never used in this country so far as known.

Installed in one mill in England but never officially approved there.

**McLAUTHLIN**

Geo. F. McLauthlin, Boston, Mass.

1894. Valve sprinkler. Upright and pendent types. Valve held in place by strut composed of levers. A

heavy iron case surrounded the sprinkler, which in the upright type was in two pieces. This case was held in place by low-fusing solder. A small chain was attached to the case and to the valve strut. When heated the iron case was released and in falling pulled the strut levers off center and opened the valve. Never used so far as known.

MERCHANT AND EVANS

See *Evans*.

MILLER

J. A. Miller, Providence, R. I.

1878. Valve sprinkler with rose or perforated distributor. Valve opened against water pressure and was operated by the expanding of brass rods placed under the sprinkler pipes. Never used so far as known.

MORRIS

Morris Sprinkler Co., Ltd., London, England.

Upright valve sprinkler of toggle-joint lever type similar to last type of John Kane. Submitted to Underwriters' Laboratories in 1907 Criticized as follows:

1. Cold flow of solder joint. 2. Premature opening. 3. Distribution. 4. Marking. 5. Design of parts. 6. Strength. 7. Workmanship.

Never used in this country so far as known.

Formerly approved in England but approval withdrawn.

Levers poorly designed and head often failed.



MORRISON

Morrison Brass Co., Toronto, Canada.

1. Upright valve sprinkler very similar to the Grinnell glass disc head.

2. Upright valve sprinkler similar to above but valve held in place by duck bill levers similar to those used in the Esty sprinkler.

Neither type used to any extent so far as known.

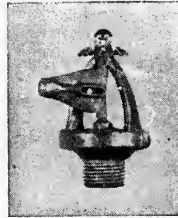

MORRISON 2.

NAGLE

Augustus F. Nagle, Chicago, Ill. Assigned to *Nagle Automatic Sprinkler Co.*

1-1890. Pendent valve sprinkler. Interior valve opening against the water pressure. Valve stem threaded into a nut which was held in a closed case by



NAGLE-1

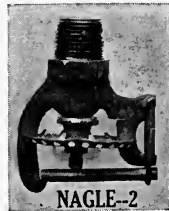

NAGLE-2

a heavy coiled spring. Spring was released by the fusing of two trip pieces soldered to projections on the outside of the case. When released the spring uncoiled and screwed the valve away from its seat. Deflector was a flat plate with raised perforated edge. See page 44.

Present rating: *Unreliable.*

2-1891. Pendent valve sprinkler. Valve held by single lever hooked at one end and secured at other end by a three-piece link.

Obsolete.

Present rating: *Unreliable.*

NAYLOR

James Naylor, Jr., Boston.

1894. Upright valve sprinkler. Valve held in place by glass strut filled with fluid that was supposed to expand when heated and break the glass. Never used so far as known.

Another type had a strut composed of two pieces of metal soldered together. Never used so far as known.

1895. Upright valve sprinkler. Valve cap held by two levers set at an angle to the vertical. Held to frame by a fusible member consisting of two thin metal discs soldered together. Light and easily broken. Never used so far as known.



NERACHER

Wm. Neracher, Cleveland, Ohio. Installed by *Neracher Sprinkler Co., Neracher & Hill Sprinkler Co.,* and later by *General Fire Extinguisher Co.*

A-1882. Pendent valve sprinkler. Valve held in place by lever hinged at one end and held at other end by a short trip lever. Long end of latter lever held by a plate bearing against a small vessel containing paraffine or similar material, fusing at about 120° F. Distribution from four curved rotating arms. Never used so far as known.

1-1884. Pendent valve sprinkler, drop deflector type. Valve held in place by cross-shaped strut with

horizontal arms soldered to frame. Lower part of strut placed at a slight angle with the vertical. Star-shaped deflector.

Obsolete.

Present rating: *Unreliable*.

1½-1886. Pendent valve sprinkler. Similar to No. 1 except releasing device. Strut consisted of triangular-shaped spring with two lower ends soldered to frame.

Obsolete.

Present rating: *Unreliable*.

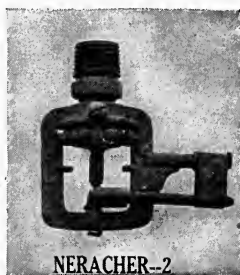

2-1887. Pendent valve sprinkler. Similar to No. 1 except releasing device. Strut consisted of one short piece and one long angular piece, the long end of which was held to a projecting arm by a two-piece triangular-shaped link. See page 58.

Obsolete.

Present rating: *Unreliable*.

2½-1887. Pendent valve sprinkler. Similar to No. 2 except that releasing device consisted of levers extending over lower end of frame and held together by a fusible link.

Present rating: *Unreliable*.

3-1888. Upright valve sprinkler. Valve held in place by four-piece lever. Outer levers of brass wire

extended to top of sprinkler and were held together by a link similar to that used in No. 2.

Out of 48 recently tested 17 per cent failed.

Practically obsolete.

Present rating: *Unreliable.*

3 $\frac{1}{2}$ -1893. Upright valve sprinkler. Similar to No. 3 except that the frame was slightly different in shape and levers were of stamped bronze. Unduly subject to the influence of corrosion.

Out of 232 recently tested by the Underwriters' Laboratories 3 per cent failed.

Rating: *Doubtful.*

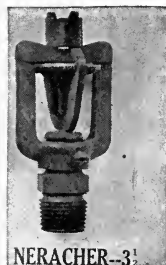

4-1895. Upright valve sprinkler. Similar to No. 3 but a much shorter head. Outer levers of stamped bronze. Toothed, perforated deflector. Reliability somewhat doubtful, due to age.

Out of 52 recently tested by the Underwriters' Laboratories 10 per cent failed from tight fit between links and parts.

Present rating: *Doubtful.*

5-1902. Upright valve sprinkler. Similar to No. 4 but somewhat shorter. Frame not adjustable.

Present rating: *Not standard; generally satisfactory.*

6-1902. Similar to No. 5 but with toothed deflector. Hollow valve cap. Approved.

Rating: *Standard.*

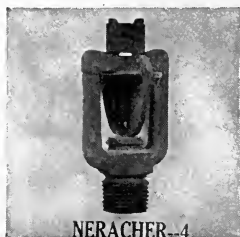

NEW YORK

New York Automatic Sprinkler Co.

Patented by *B. P. Hall of Fanwood, N. J.* Assigned to
New York Automatic Sprinkler Co.

1911. Upright valve sprinkler with two-piece curved strut.

Reported upon by the Underwriters' Laboratories, July, 1912. Features criticized:

1. Deterioration from loading and corrosion.
2. Probability of premature opening.
3. Distribution.
4. Lack of uniformity of manufacture.
5. Design.
6. Construction details.

Rating: *Unreliable.*



NEW YORK.

NEW YORK AND NEW HAVEN

Made by *Foskett & Bishop, New Haven, Conn.; New York & New Haven Automatic Sprinkler Co., New York; John Simmons, New York.*

1-1889 (December). Mill type. Patented by *V. A. Harder of Brooklyn, N. Y.* Interior valve sprinkler of elbow type. Valve spindle held by two hooked levers with ends covered by a two-piece fusible link similar to

the Walworth link. Large deflector with raised slotted edge. Threaded for $\frac{3}{4}$ -inch fitting.

Practically obsolete.

Present rating: *Unreliable*.



N.Y. & N.H.-1



N.Y. & N.H.-2

2-1889 (July). Riveted lever type. Patented by *Daniel C. Stillson of Somerville, Mass.* Interior valve sprinkler of elbow type. Similar to No. 1 except that levers were pivoted and deflector was smaller with raised perforated edge.

Practically obsolete.

Present rating: *Unreliable*.

NEWTON

Robert W. Newton, Providence, R. I. Installed by the inventor.

Patents taken out in 1891-1892 and 1893 for sprinkler heads that were never put on the market so far as known.

1894. Upright valve sprinkler. Metal valve disc held in place by strut consisting of five pieces at an angle, and three horizontal.

The horizontal pieces were soldered to a flat surface. Deflector had a raised perforated edge. This head was used to



NEWTON

a considerable extent in Rhode Island and Eastern Massachusetts. After about ten years use this sprinkler gave trouble from sticking, especially when corroded. Now considered defective. Practically all have been replaced. Used to some extent in England.

Practically obsolete.

Present rating: *Very unreliable.*

Note: The sprinkler was slightly modified in patents taken out in 1902-1903 and 1905, the latter being assigned to the General Fire Extinguisher Co.

NEWTON

Newton Fire Extinguisher Co., Ltd., London, England.

Upright valve sprinkler with diaphragm outlet.

Valve disc held by levers and link similar to those used in the International sprinkler.

Not used in America so far as known.

Used extensively in England and other parts of the world.



NIAGARA-HIBBARD

Manufactured by *Niagara Fire Extinguisher Co., Akron, Ohio.*

A-1902. Upright valve sprinkler. Frame similar to Hibbard sprinkler, levers and link similar to Niagara sprinkler. V joint in link. Projections on frame where

levers would touch. Stamped Niagara on one side and Hibbard on other side.

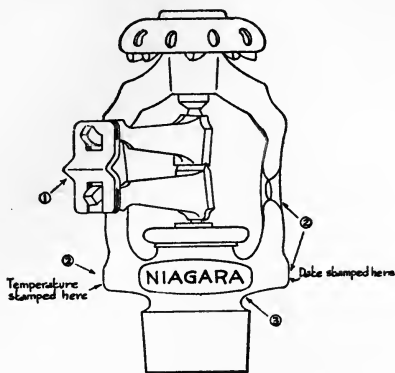

NIAGARA-HIBBARD A-1902.

Underwriters' Laboratories report, 1902. Features criticized:

1. Effects of corrosion and loading.
2. Solder in high degree patterns.
3. Structural weakness.
4. Cap and construction details.

Rating: *Unreliable.*

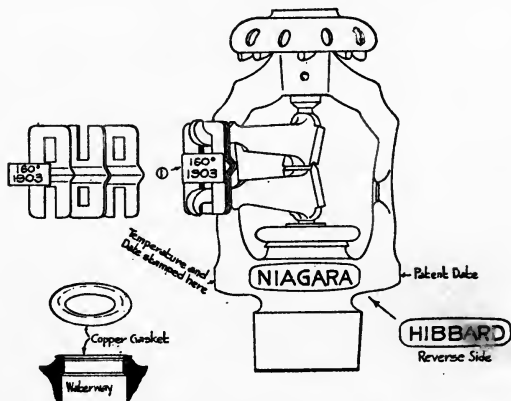

NIAGARA-HIBBARD A₂-1903.

A₂-1903. Similar to 1902 type but with point on link reversed (pointing inward). Date and temperature marked on link.

Out of 55 recently tested by the Underwriters' Laboratories 2 per cent failed.

Rating: *Doubtful.*

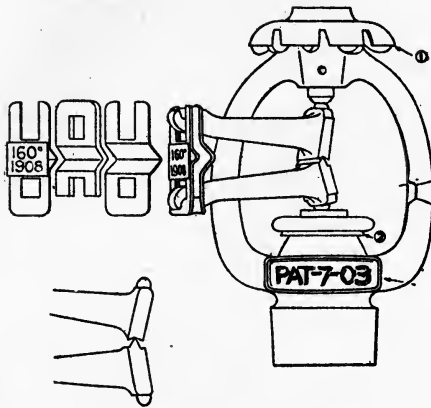

NIAGARA-HIBBARD B-1904.

B-1904. Similar to A but with more rounded frame, toothed deflector and longer levers. Block tin gasket in earlier issues; copper ring gasket in later issues. Nia-Hib cast on one side of wrench head and patent date on the other side.

Installed by Niagara Fire Extinguisher Co., Akron, Ohio. Approved by the Underwriters' Laboratories in 1904. Withdrawn from approval in 1912, inasmuch as name of the device was changed to Niagara when Mr. Geo. E. Hibbard withdrew from the Niagara Fire Extinguisher Co. (See Niagara.)

Rating: *Satisfactory.*

NIAGARA

Manufactured by *Niagara Fire Extinguisher Co., Akron, Ohio,* and after 1912 by the *Ohio Sprinkler Co., Youngstown, Ohio.*

B-1912. Practically the same head as Niagara-Hibbard B. Approved by the Underwriters' Laboratories.

Rating: *Standard.*



PARMELEE

Henry S. Parmelee, New Haven, Conn. Made by J. R. Brown & W. A. Foskett, New Haven, Conn.

Installed by *Foskett & Bishop, New Haven*, by the *Providence Steam & Gas Pipe Co.* and others.

First patent, 1874, showed a valve sprinkler held to its seat by fusible solder. Perforated distributor. Sprinkler fed by small pipe until an auxiliary valve was opened by the reduction in pressure.

Never used so far as known. See page 17.

1-1874 (about). Upright, valve sprinkler. Interior valve held in place by hinged lever the end of which was fastened to an arm by means of a heavy spring and fusible link. Perforated distributor.

Used in Mr. Parmelee's piano factory (probably the first automatic sprinkler equipment ever installed). See page 17.

2-1874 (about). Upright, valve sprinkler. Interior valve held in place by a wooden strut the upper end of which had a bearing against a fusible washer. Perforated distributor. This head was also used to a limited extent in Mr. Parmelee's piano factory. See page 18.

3-1875. Upright, sealed sprinkler. Brass cap soldered over a perforated distributor. Threaded on inside. See page 18.

4-1878. Upright, sealed sprinkler. Brass cap soldered over a rotating turbine distributor. Threaded on inside. See page 19.

5-1878. Upright, sealed sprinkler. Similar to No. 4 but redesigned by Mr. Grinnell. The head was made more sensitive by recessing under the solder joint so that the heated air could circulate on each side of this joint. Threaded on the outside for a half inch fitting. Slow in action and easily damaged.



Field experience very satisfactory for some years. See page 19.

All types now obsolete.

Present rating: *All types unreliable.*

PHELPS

Fred A. Phelps, Laconia, N. H.

1-1904. Upright valve sprinkler. Metal valve cap held in place by a seven-piece strut in the form of a double rectangle. Soldered surfaces corrugated.

2-1907. Sample similar to above tested by Underwriters' Laboratories, 1907, criticized as follows:

1. Deflector. 2. Markings. 3. Soldering. 4. Strength.

3-1910. Experimental sample submitted to Underwriters' Laboratories criticized as follows:

1. Features of design and construction. 2. Hard and extra hard degree solders. 3. Effects of loading and corrosion.

None of the types ever used so far as known.



PHELPS 2.

PHENIX

Albert Blauvelt, Chicago, Ill.

1917. Upright valve sprinkler. Valve cap *a* held in place by an S-shaped strut *b* bearing on a curved lever *c*. Upper end of lever fitted into a slot in curved connection strip *d* above the deflector *e*. This curved strip held in place by a capsule *f* containing a plunger resting on fusible solder in granular form *h*. When heated the solder melts and allows the piston to fall, thus releasing the curved connector strip and the lever attached to it. Fusible solder contains some mercury.

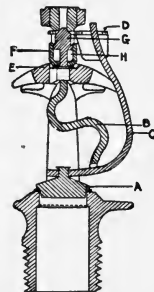

PHENIX.
(Section.)

Criticized by Underwriters' Laboratories, 1917, as follows:

1. Difficulty in packing and shipping without injury. 2. Durability. 3. Certain parts not strong enough to withstand ordinary external strains. 4. Not entirely reliable in operation.

Used to some extent in the Middle West.

Rating: *Not standard.*

PHOENIX

Patented by *Jarvis Hunt, Chicago.*

Assigned to *Phoenix Fire Extinguisher Co.*

1-1904. Upright valve sprinkler with diaphragm. Metal valve cap covered a raised orifice in diaphragm and was held by three-piece strut with a projection at an angle of about 45 degrees.

Never used so far as known.

A-1905. Upright valve sprinkler similar to No. 1 except in shape of strut. Similar in appearance to Grinnell glass disc sprinkler except strut and diaphragm. Approved by the Underwriters' Laboratories, 1905.

Withdrawn from approval, 1909. Manufacture discontinued.

Field experience limited but generally satisfactory except in the matter of leakage and premature opening.



Out of 171 recently tested by the Underwriters' Laboratories 2 per cent failed from adhesion at the seat.

Present rating: *Fairly satisfactory.*

Note: The Phoenix Fire Extinguisher Co. was backed by the late Paul Morton, his brother and others. The company went out of business in 1909.

PIERCE

Octavius Pierce, Chicago, Ill.

Assigned to *Underwriters' Fire Sprinkler Co.*

1894. Upright valve sprinkler. Valve held in place by four-piece strut of triangular shape. Fixed toothed deflector. Used to some extent in the Central West. Subject to crawling and leaking. See page 60.

Present rating: *Unreliable.*

PRENTISS

See *Draper.*

ROCKWOOD

Geo. I. Rockwood, Worcester, Mass.

Manufactured and installed by *Worcester Fire Extinguisher Co.* Later by *Rockwood Sprinkler Co.*

1905. Patents taken out on upright valve sprinkler with single deck deflector.



A-1906. Upright valve sprinkler. Metal valve cap with pure silver washer held in place by four-piece strut of triangular shape. Double deck deflector, part being over and part under the frame.

Approved in 1907 by the Underwriters' Laboratories.

Field experience not satisfactory in the matter of leakage and premature opening. Have been practically all removed. See page 60.

Present rating: *Unsatisfactory.*

Later this head was slightly changed by installing a lump of solder at one end of the soldered lever to give additional strength.

B-1906. Slight modification of A. Key placed in top of soldered lever of strut to give additional strength.

Not approved by Stock Companies. Used in risks insured in Mutual Companies.

Present rating: *Satisfactory*.

C-1910. Similar to A except solder joint strengthened by installing a reinforcing wire.

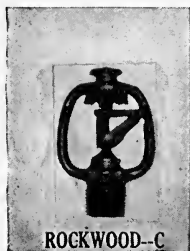

Approved by the Underwriters' Laboratories. Many in use.

Present rating: *Satisfactory*.

D-1911. Similar to C but with single deck deflector.

Approved by Underwriters' Laboratories and the Mutual Companies. Many in use. See page 60.

Present rating: *Standard*.

RUNDLE SPENCE

Made by *Rundle Spence Automatic Sprinkler Co., Milwaukee, Wis.*

R-1911. Upright valve sprinkler. Almost identical with Neracher Improved 1902 sprinkler. No distinguishing marking except that rating and year of manufacture were stamped on link.

A few were installed in the Middle West.

Rating: *Questionable*.

2-1912. Similar to 1911 type except that the letters R. S. were cast at an angle on the upper edge of the frame and notches were provided in levers to prevent link from coming in contact with top frame.

Underwriters' Laboratories report, March, 1913, makes following criticisms:

1. Effects of loading and corrosion. 2. Adhesion of valve cap and disc to seat. 3. Inaccuracies in high test solder. 4. Factors of safety in link, frame and cap. 5. Lack of uniformity of manufacture. 6. Construction details.

Rating: *Questionable.*

A-1913. Similar to 1912 type but letters R. S. in a vertical position and further from link. Rating and date stamped on link.

Approved Sept., 1913, by the Underwriters' Laboratories. Withdrawn, 1915.

Manufacture discontinued.

Rating: *Satisfactory.*



RUNDLE
SPENCE.

RUTHENBURG

Marcus Ruthenburg, Cincinnati, Ohio.

1885. Pendant valve sprinkler.

Rubber valve disc of spherical form held in place by long thin lever. Lever held to arm by cylindrical link of solid solder.

Fixed saucer-shaped deflector.

Used to a limited extent in the Middle West. Crude and subject to crawling. See page 37.



Obsolete.

Present rating: *Very unreliable.*

SHAW

C. B. Shaw, Kirkwood, Mo. Made by Shaw Manufacturing Co., St. Louis, Mo.

1-1897. Upright valve sprinkler with keyed strut. Key released by expansion of alcohol or ether in a closed vessel with corrugated sides. Slightly modified in 1899. Subject to corrosion. Unreliable principle of release. A few equipments were installed in the neighborhood of St. Louis, Mo. See page 45. Out of 14 recently tested 50 per cent failed.

Present rating: *Very unreliable.*



SIMMONS

J. Simmons Co., New York.

Upright valve sprinkler. Practically a duplicate of the Stantial.

Never used so far as known.



SIMPLEX

Made by *Crowder Bros., St. Louis, Mo.*

1902. Upright valve sprinkler. Porcelain valve cap held by toggle-joint levers and link. Criticized by Underwriters' Laboratories as follows:

1. Releasing device.
2. Effects of loading and corrosion.
3. Leaking point.
4. Cap.
5. Disc.
6. Deflector.
7. Marking.
8. Structural weakness.
9. Construction details.

Never on market so far as known.

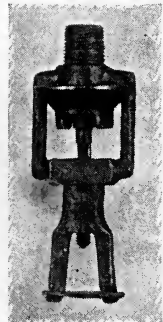

SMITH

Darius B. Smith, Pine Meadow, Conn.

1885. Pendent valve sprinkler of drop deflector type. Valve stem threaded

into two parallel vertical levers. Levers held together by two-piece link. Conical-shaped deflector. A few hundred made. Used only in Mr. Smith's own factory. Gave trouble from leakage due to turning of threaded stem from vibration.

Obsolete.

Present rating: *Very unreliable.*

STANDARD

Made by the *National Fire Extinguisher Co., Kansas City, Mo.*

1902. Upright valve sprinkler. Valve cap held by levers of toggle-joint type and fusible link. Quite similar to Hibbard sprinkler. Criticized by the Underwriters' Laboratories in 1903 as follows:

1. Fusing point. 2. Releasing device. 3. Effects of corrosion and loading. 4. Structural weakness. 5. Solder in high degree pattern. 6. Marking. 7. Workmanship.

Out of 77 recently tested by the Underwriters' Laboratories 8 per cent failed from adhesion at the seat.

No longer made.

Rating: *Unreliable.*



STANTIAL

Otis T. Stantial, Chicago, Ill. Made by *Independent Fire Sprinkler Co., Chicago, Ill.*

1895. Upright valve sprinkler. Valve cap held in place by strut with curved projecting member. Report of Underwriters' Laboratories, 1903, criticized:

1. Fusing point. 2. Releasing device. 3. Effects of corrosion and loading. 4. Cap. 5. Solder in high degree pattern 6. Marking. 7. Distribution.

Out of 160 recently tested by the Underwriters' Laboratories 6 per cent failed:

Used to a limited extent.

Present rating: *Unreliable.*

STAR

Wm. T. Montgomery of Wakefield, Mass. Assigned to *Star Manufacturing Co. of Boston.*

1886. Pendent valve sprinkler. Metal valve with stem held in place by lever, one end being hooked to casting and the other attached to a projection by a solder pin. Large star-shaped deflector. Installed to a considerable extent in New England by the Star Manufacturing Co. Sold out to Providence Steam & Gas Pipe Co. Field experience satisfactory for a number of years.



Obsolete.

Present rating: *Unreliable.*

STECK

Ernst F. Steck, Chicago, Ill. Assigned to *Fire Extinguisher Manufacturing Co.*

1896. Upright valve sprinkler with valve cap held in place by triangular-shaped strut.

Never used so far as known.

STRATTON

W. H. Stratton, New Haven, Conn., and later of *Providence, R. I.,* and *Hartford, Conn.*

1-1885. Pendent valve sprinkler of drop deflector type. Valve held in place by two levers hooked to frame and soldered together at lower side of head.

Never used so far as known.

2-1893. Pendent valve sprinkler. Valve held in place by spindle passing through deflector and resting on a thimble soldered to frame. All working parts of sprinkler protected against corrosion by a papier maché protecting cover.

Never used so far as known.

3-1896. Upright valve sprinkler. Valve seated on a hole in flexible diaphragm. Valve consisted of a frangible stopper adapted to contain a bursting charge. Stopper was clamped in place and when heated it was broken into small pieces.

Whole head enamelled to prevent corrosion.

Slightly modified in 1902.

Never used so far as known.

SWAN

Phineas W. Swan, Winchester, Mass.

1-1892. Pendent valve sprinkler. Valve cap held in place by levers of toggle-joint type curved and pointing upwards. Levers held by two-piece fusible link. Fixed toothed deflector.

Never used so far as known.

2-1895. Upright valve sprinkler similar to No. 1 but with slotted revolving deflector. But little used, if at all.

Present rating: *Unreliable.*



TALCOTT

Charles W. Talcott, Woonsocket, R. I.

Installed to some extent by inventor who afterwards installed other makes of sprinklers.

1-1882. Pendent valve sprinkler. Interior valve held in place by hinged cap, the latter being held by fusible pin. Rose distributor.

Obsolete.

2-1882. Pendent valve sprinkler. Valve of soft metal held in place by two hinged levers bearing directly on the valve cap. Levers were curved and extended around bottom of sprinkler where they were soldered together. Rose distributor. Obsolete.

Present rating: *Very unreliable.*



TALCOTT

TESSIER

Made by *Joseph Tessier, New Bedford, Mass.*

Submitted to Underwriters' Laboratories, 1901. Un-developed device.

Practically all features criticized.

Never used so far as known.

TITAN

George Mills & Co., Ltd., Manchester, England.

1. Pendent valve *sprinkler of drop deflector type; valve held by lever and rivet-shaped fusible link.



TITAN



TITAN_2

2. Upright valve sprinkler. Valve disc held in place by strut the parts of which are held together by a rivet-shaped fusible piece similar to that used in No. 1. Apparently easily clogged by dirt and corrosion.

Installed in England and many other parts of the world. Not used in America so far as known.

TURNER AND GARDINER

1895. Valve sprinkler with perforated distributor. Valve spindle held in place by long lever hinged at one end and attached to piping or to ceiling by a spring and cotton cord.

Never used so far as known.

UNITED STATES

United States Automatic Sprinkler Co., New York City.

A-1917. Upright valve sprinkler. Similar to the International Sprinkler. Valve held in place by toggle-joint levers held by link. Link composed of two plates soldered together, there being slight projections and indentations in each fitting into each other.

Now being tested by the Underwriters' Laboratories.



UNITED STATES.

UNIVERSAL

Universal Automatic Sprinkler Co., Philadelphia, Pa.

John Kane, General Manager. Later reorganized as the *International Sprinkler Co.* This company previously installed the J. Kane sprinklers No. 1 and No. 2.



UNIVERSAL--1



UNIVERSAL--2

1-1896. Upright valve sprinkler. Valve held in place by straight strut. Perforated and toothed deflector.

Not used so far as known.

2-1899. Upright valve sprinkler. Similar to No. 1 except valve cap held by levers of the toggle-joint type with link.

Present rating: *Unreliable.*

Note: There was also a sprinkler similar to No. 1, but with an irregular-shaped three-piece strut, invented by Robert Wood. Never used so far as known.

UP-TO-DATE

Made by *U. T. D. (Up-to-date) Sprinkler & Supply Co., Chicago, Ill.*

1899. Upright valve sprinkler. Valve cap held in place by strut. Small smooth deflector.

Criticized by Underwriters' Laboratories, 1905, as follows:

1. Crude workmanship.
2. Subject to crawling and leakage.
3. Distribution faulty.

Out of 165 recently tested by the Underwriters' Laboratories 21 per cent failed.

Present rating: *Unreliable.*



UP-TO-DATE



LACONIA

OR VOGEL.

VOGEL

Made by *H. G. Vogel Co., New York.*

1904. Upright valve sprinkler. Valve cap held in place by double strut. Fixed toothed deflector. Two horizontal projections on casting just above threaded portion. Experimental sample criticized by Underwriters' Laboratories in 1904 as follows:

1. Structural weakness. 2. Soldered struts. 3. Spring. 4. Distribution. 5. Markings. 6. Construction details.

Never used so far as known in America.

Approved in England under the name Laconia, but not used there to any extent.

WALWORTH

Patents by *C. C. Walworth* and *O. B. Hall of Boston*.

Made and installed by *Walworth Manufacturing Co., Boston*. Patents were taken out in Feb., 1883, and July, 1883, by *C. C. Walworth* on experimental samples that were never used to any extent.



1-1883 (October). **Soldered arm type.** Patented by *C. C. Walworth* and *O. B. Hall*. Pendant valve sprinkler. Valve held by stem resting against a rocker arm lever. Long arm of lever soldered to frame. Not a sensitive head.

Obsolete.

Present rating: *Very unreliable*.

2-1883. **Solder link type.** Similar to No. 1 except that whole deflector dropped when head opened. Long arm of lever held to a projection on frame by an all-solder link. This link caused leakage by stretching and later a two-piece metal link was used. See page 36.

Obsolete.

Present rating: *Unreliable*.

2 A-1883. **Drop deflector type.** Similar to No. 2 but with link composed of two U-shaped pieces of brass soldered together.

Rating: *Unreliable.*

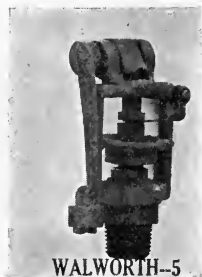

3-1885. **Soldered deflector type.** Pendent valve sprinkler similar to No. 2 except that deflector was large and stationary. Valve disc passed through hole in center of deflector. There were several slight modifications of this sprinkler and in later types a link was used in which the two parts were placed side by side instead of one being entirely within the other. See page 36.

Present rating: *Unreliable.*

4-1888. **Ordinary type.** Pendent valve sprinkler. Similar to No. 3 but with a smaller and smoother deflector. Hexagonal casting for wrench just below threaded portion. See page 61.

Present rating: *Unreliable.*

5-1888. **Upright, spring type.** Similar to No. 4 but arranged to be placed upright. Steel spring tended to force valve open when link melted. Practically obsolete.

Present rating: *Unreliable.*

6-1892. **Smooth deflector type.** Upright valve sprinkler. Valve cap attached to a hinged lever, the upper end of which was held to a projection on the cast-

ing by a fusible link. Small smooth deflector. Poor distribution. Nearly obsolete. See page 61.

Present rating: *Unreliable.*



7-1894. Ordinary upright type. Similar to No. 6 but with perforated deflector.

Present rating: *Unreliable.*

8-1898. Improved pendent type. Similar to No. 6 but with improved toothed deflector, more clearance of levers, etc.

Present rating: *Unreliable.*

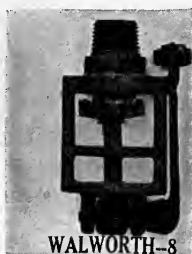

9-1899. Improved upright type. Similar to No. 7 but with toothed deflector and more clearance of moving parts.

Present rating: *Unreliable.*

Note: There are several other minor variations of the above types. Most of the Walworth heads made after 1892 had double links as a safeguard against crawling of solder in the single link. These were generally wired together so that the outer one would

not slip off. A few were wired at the side instead of at the end, thus binding the moving parts of the link together and causing failure to operate.

Melting points of many of the high test patterns were irregular. Walworth heads had a satisfactory field experience up to 1912, when tests showed them to be unreliable.

Out of about 1500 tested by the Underwriters' Bureau of New England between 1911 and 1914, 30 per cent failed.

They are now mostly replaced.

WESTON

A. L. Weston, Adams, Mass.

1899. Upright valve sprinkler. Valve cap held by rectangular strut composed of several pieces soldered together and with a concealed spring.

Report of Underwriters' Laboratories, 1902, criticized:

1. Fusing point. 2. Structural weakness. 3. Releasing device. 4. Cap. 5. Solder in high degree patterns.

Never used so far as known.



WESTON.

WHITING

Francis Whiting, Chelsea, Mass.

1881. Pendent, water-joint type. Perforated distributor, fan shape in cross section. Cap soldered to flanged edge. Used to some extent about 1884. Sold out to Burritt Hardware Co. of Waterbury, Conn.

Obsolete. Not a sensitive type. See page 28.

Present rating: *Unreliable.*

WILBER

Wilber & Son, Bolton, England.

1889. Pendent sprinkler. Valve disc held in place by levers soldered together. Water distributed from a circle of holes discharging onto a loose toothed ring.

Not used in this country so far as known.

WILSON

W. A. Wilson.

1882. A large thimble-shaped cap fitted over an orifice and was held in place by a strap of thin metal containing a fusible joint.

Never used so far as known.

WITTER

Witter & Son, Bolton, England.

1. Pendent valve sprinkler. Valve held in place by lever hooked to frame at each end and with adjusting screw passing through the center. Fusible joint consisted of two flat angular parts pivoted at top and soldered together at lower end. Spring under valve disc.



E-1906. Upright or pendent valve sprinkler. Valve disc held in place by strut. Spring under valve disc.

Not used in America so far as known.

Used extensively in England and other countries.

WOOD

Robert Wood, Philadelphia, Pa.

1896. Mr. Wood while with the Universal Sprinkler Co. of Philadelphia invented several sprinklers. The frame of the Universal sprinkler was used but the valve discs and releasing devices were of several patterns, most of which resembled those used in other sprinklers.

None of these were ever used so far as known.

Summary of Tests

Made on 6277 clean sprinklers from the field during the last few years by the Underwriters' Laboratories, Underwriters' Bureau of New England, Underwriters' Bureau of Middle and Southern States and the St. Louis Fire Prevention Association. Corrected to April, 1918.

Type.	No. Tested.	Operative.	Slow.	Doubtful.	Failure.	Per cent Failure.	% Doubtful or Failure.
Babcock.....	4	2	1	1	25	25
Cataract A.....	6	6	100
Clapp No. 1.....	68	45	2	10	11	16.2	31
Clapp No. 2.....	13	13	0	0
Esty 5 (1896).....	51	44	4	1	2	3.9	5.9
" 6.....	30	27	1	2	6.6	6.6
" 6½.....	3	3	0	0
Garrett A.....	6	6	0	0
Grinnell, 1.....	5	5	0	0
" A.....	44	20	6	4	14	31.8	40.9
" B.....	30	14	2	3	11	36.7	46.7
" C.....	68	39	30	6	3	4.4	13.2
" D.....	213	84	52	29	48	22.5	36.1
" glass disc (1890-03).....	514	414	87	9	4	0.8	2.5
Hibbard, 1.....	16	16	0	0
" 2.....	97	50	9	26	2	2.1	29
" 3.....	193	63	23	100	7	3.6	55.4
" 3-A.....	599	386	23	159	31	5.2	31.7
" 4 (1901).....	294	190	5	35	64	21.8	33.7
" 5.....	13	13	0	0
Hill.....	184	120	27	3	34	18.4	20.1
International, 1 (1900).....	34	32	2	0	0
" A (1902).....	105	84	20	1	0	1
J. Kane, 1 (Universal).....	6	4	2	0	33.3
" 2.....	139	96	21	9	13	9.4	15.8
" 3 (1900).....	12	7	5	0	0
" 4.....	74	53	17	3	1	1.4	5.4
" 4½.....	6	6	0	0
W. Kane, 3 (Bulb Root).....	57	55	1	1	0	1.8
" 4 (Perfection).....	28	23	3	1	1	3.6	7.2
Kersteter.....	28	15	7	1	5	17.9	21.4
Lapham, A (1910).....	33	32	1	0	3
Mackay, 1892 (Mfr. 1).....	14	3	2	3	6	42.8	64.2
Manufacturers, 2.....	30	19	4	5	2	6.7	23.3
" 3.....	12	4	3	5	41.6	66.7
" 4.....	7	6	1	14.3	14.3
" (Long Lever).....	25	9	6	1	9	36	40
" A.....	555	335	69	85	66	11.9	27.2
" B.....	225	185	27	5	8	3.6	5.8
Neracher, 2.....	5	5	0	0
" 3.....	48	39	1	7	1	2.1	16.7
" 3½.....	232	208	18	3	3	1.3	2.6
" 4.....	52	43	3	6	9.6	9.6
Newton.....	24	13	1	10	41.6	45.9
New York & New Haven.....	14	5	9	0	0
Niagara Hibbard, A (1902).....	91	89	1	1	1.1	1.1
" A (1903).....	55	54	1	0	1.8
" B.....	42	42	0	0
Phoenix, A.....	171	140	27	3	1	0.6	2.3
Rockwood, A.....	10	5	0	0
Rundle Spence.....	173	170	1	1	1	0.6	1.2
Shaw.....	14	6	1	1	6	42.8	50
Standard.....	77	71	6	7.8	7.8
Stantial.....	160	143	8	3	6	3.8	5.6
U. T. D.....	165	111	20	34	0	20.6
Walworth drop deflector, 2-A.....	21	15	6	0	0
" sol. def., 3.....	94	29	32	6	27	28.8	35.1
" ord. pend., 4.....	486	237	150	41	58	11.9	20.3
" upr., 7.....	99	50	18	12	19	19.2	31.3
" imp. pend., 8.....	113	62	26	4	21	18.6	22.1
" upr., 9.....	290	84	84	24	98	33.8	42.1

APPENDIX II

Standard Report Blank for Inspection by the Assured

NAME

LOCATION

VALVES (Inside Gates)

Note. — All gate valves to be secured open with leather straps fastened with padlocks riveted or sealed and keys to be held by responsible parties. Each valve to be inspected by turning valve one turn to insure its being wide open and in good working order. Drip valves to be strapped closed in a similar manner.

Note. — Valves under approved supervisory system need not be secured.

List of valves:

Location.	Open.		Strapped.	
	Yes.	No.	Yes.	No.
1.				
2.				
3.				
4, etc.				

VALVES (Outside Post Indicator Gates and Valves in Pits)

Note. — To be secured and inspected in the same way as inside valves.

List of valves:

Location.	Open.		Strapped.	
	Yes.	No.	Yes.	No.
1.				
2.				
3.				
4, etc.				

Give numbers of any of the above valves found closed, part closed, not strapped, closed temporarily at any time since last inspection. Explanation.

Note. — Drip valves to be tested weekly.

DRY SYSTEMS (Dry Valves)

Note. — *Dry valves should be tested for water column and condition of spring at least every three months. Should be tripped at least once a year.*

Note. — *When system is first set, test for water column every few days.*

List of Valves:

Location.	Air Pressure.
1.	
2.	
3.	
4, etc.	

Dry valve closet in good order and properly heated.....

Give number of any air systems into which water has entered during week.....Explanation.....

Are hand hole plugs in place.....

Is flanged dummy in place.....

ALARM CONNECTIONS

Note. — *All controlling valves or cocks for alarm devices to be sealed or strapped open. Special instructions to be given regarding testing alarm valves.*

VALVE CONTROLLING ALARM

List of Valves:

Location.	Open.		Strapped.		Tested.		In Order.	
	Yes.	No.	Yes.	No.	Yes.	No.	Yes.	No.
1.								
2.								
3.								
4, &c.								

Give numbers of any alarm devices out of service..... Explanation.....

GRAVITY TANK

Full..... Contents frozen..... Tell-tale in order.....

Condition of tank, hoops and supports.....

Remedied..... When.....

PRESSURE TANK

Water Level. Air Pressure.

Note. — *Gage glass cocks to be kept closed except while inspecting.*

STEAM PUMP

Note. — *Pumps should be given a thorough test with rated number of hose streams at least twice a year, spring and fall. They should be started once a week, and water discharged through relief valve or otherwise to make certain pump is in order.*

Valves in steam connection from boilers to pump wide open.

Minimum steam pressure for pump during week.

Started.

Tested through. hose streams. Condition.

Supply of oil on hand.

AUTOMATIC REGULATORS

Regulator controlling valves wide open. water pressure maintained. Pump started and regulator operated at. pounds.

ELECTRIC PUMP

Note. — *Pumps should be given a thorough test with rated number of hose streams at least twice a year, spring and fall. They should be started once a week and water discharged through relief valve or otherwise to make certain pump is in order.*

Any interruption of current supply. Condition of contact points on all switches.

Started. Tested through. hose streams.

Condition.

Automatic controller in order. Water pressure maintained Supply of oil on hand.

ROTARY PUMP

Note. — *Pumps should be given a thorough test with rated number of hose streams at least twice a year, spring and fall. They should be started once a week and water discharged through relief valve or otherwise to make certain pump is in order.*

Started. Tested through. hose streams.

Condition. Supply of oil on hand.

AUTOMATIC SPRINKLERS

Steamer connection.....in place.....ready for service.
 Any corroded, bent, whitewashed, gilded or painted, covered with
 dirt or grease, distribution of water from sprinklers obstructed

 Is there a clear space of at least two feet below the ceiling or roof,
 free from storage or other obstruction. Note any exceptions.....
 Any operated since last inspection.....Any additions needing
 sprinklers.
 Any extra heads.....

FIRE PAILS

Number..... In place..... Full.....

STAND PIPES

Water on stand pipes.....Equipment for same in good condition

CHEMICAL EXTINGUISHERS

Note. — These should be recharged at least once a year.

Number in place..... Date tested and charged.....

FIRE DOORS

Closed and fastened nights, Sundays and holidays and all times
 when not in use.....
 Will all fire doors close easily.....Will automatic doors close when
 weight is released..... Note any fire doors in need of repairs
 :.....Automatic attachments in order.....

SHUTTERS AND WIRED GLASS WINDOWS

Closed and fastened nights, Sundays and holidays and all times
 when not in use.....
 Will all shutters or windows close easily..... Note any shutters
 or windows in need of repairs.....

HYDRANTS AND HYDRANT HOUSES

*Note. — Each hydrant should be given a thorough test by flushing
 at least twice a year, spring and fall. One turn to open should be
 sufficient at other inspections.*

Hydrants open easily.....Free from snow and ice and easily
 accessible.....

Hose, Play Pipes, Spanners, Hydrants, Wrenches, Rubber Washers, Axes, Lanterns, Nozzle Holders

In their proper place and ready for use. Condition.

Note. — *Each hose house or stand pipe can be numbered and reported upon separately.*

ELEVATOR AND STAIR DOORS OR TRAPS

In order and kept closed when not in use.

Note any exceptions. Condition of latches or other hardware.

CLEANLINESS

Oily waste well cared for. Basements clean. Yard kept free from combustible material. Belt enclosures clean. Clothes closets and water closets clean. Shafting and bearings well cared for. Clean under benches. Note any suggestions as to possible improvements in cleanliness.

Remarks and suggestions.

Signed,

Date

Supt.

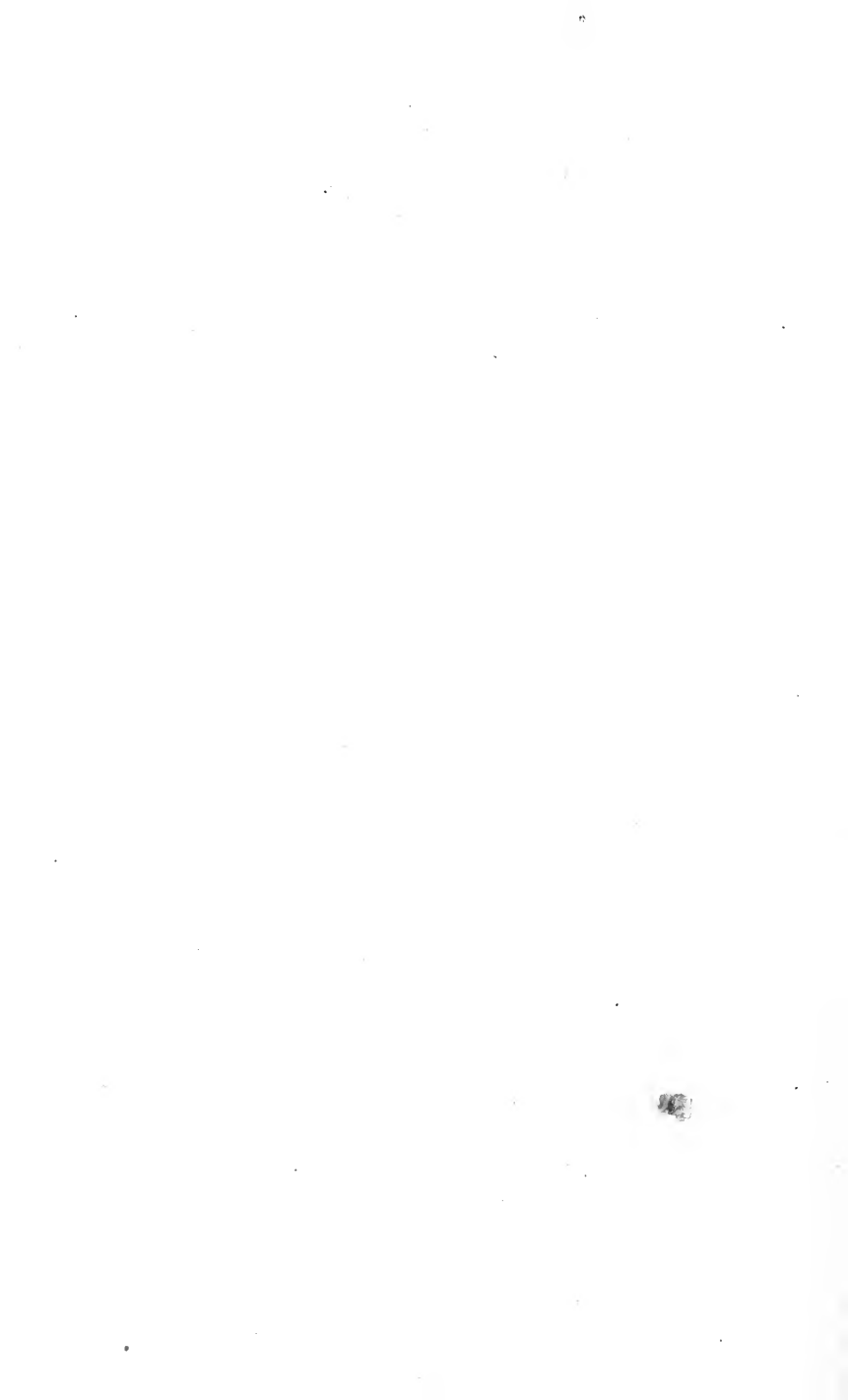

INDEX

- A.
- Acid charge, Sypho Chemical system, 343.
- Across center feed for sprinklers, 108.
- Adam sprinkler, 353.
- Adkins sprinklers, 353.
- Advantages, combined heat and sprinkler system, 333.
- Ætna sprinkler, 353.
- A. F. M. sprinkler, 355.
- Age limit of sprinklers, 78.
- Air compressor for dry systems, 191.
- Alarm service, efficiency of, 302.
- Alarm valve, Sypho Chemical system, 349.
- Alarm valves, types, 137.
- Alarm valves, installation, 143.
- Alarm valves, rules for designing, 145.
- Alarm valves, National Board rules, 146.
- Alarm valves, testing, 147.
- Alarm valves, defects, 138, 149.
- Alarm valves, fire record, 149.
- Alarm valves, cost of, 149.
- Alarm valves, tests of, 295.
- Albion sprinkler, 354.
- Alert sprinkler, 354.
- Alexander sprinkler, 354.
- Allen & Reed sprinklers, 354.
- Allis sprinkler, 355.
- Allis-Chambers-Bullock, Ltd., fire of 1911, 307.
- American Fire Extinguisher Co., 50.
- American sprinkler, 355.
- Approved sprinklers, New Eng. Ins. Exch., 74.
- Approved sprinklers, Factory Mutuals, 74.
- Approved sprinklers, Nat. Board of Fire Underwriters, 1914, 75.
- Armstrong Cork Co. fire, 115.
- Ashcroft sprinkler, 41.
- Associated alarm valve, 150.
- Associated Automatic Sprinkler Co., 53.
- Associated automatic sprinklers A, B, 54, 356.
- Associated alarm valve, 150.
- Associated dry valve, 195.
- Assured, inspection blank for, 439.
- Auditoriums, sprinklers in, 90.
- "Automatic" Sprinkler Co. of America, 357.
- Automatic sprinkler, definition, 10.
- Automatic sprinkler, patents, 10.
- B.
- Babcock sprinkler, 63, 357.
- Bach sprinkler, 358.
- Baltimore conflagration, 1906, 304.
- Barnes, Charles, sprinklers A, 1 and 2, 25, 358.
- Barr, Edward, Co., 49.

- Beech sprinkler, 359.
 Birkett sprinkler, 359.
 Bishop, John W., sprinkler 2 $\frac{1}{4}$,
 45, 361.
 Bishop, John W., sprinklers 1,
 1 $\frac{1}{2}$ and 2, 26.
 Bishop, John W., sprinklers A,
 1, 1 $\frac{1}{2}$, 359.
 Bishop, John W., sprinkler 2,
 360.
 Bishop, John W., sprinklers 2 $\frac{1}{4}$,
 2 $\frac{1}{2}$, 3, 3 $\frac{1}{2}$, 4, 361.
 Bishop, Joseph, sprinkler, 362.
 Bishop sprinklers, 45.
 Bishop dry valve, 193.
 Blank, inspection by Assured,
 439.
 Blank for sprinkler leakage, 313.
 Blauvelt (Phenix) sprinkler, 362.
 Boston Chamber of Commerce
 report on fire prevention, 324.
 Briggs sprinkler, 40.
 Brown, Durrell Co. fire of 1893,
 303.
 Brown dry valve, 198.
 Brown, J. R., sprinkler 1, 29, 46,
 362.
 Brown, J. R., sprinkler 2, 30, 362.
 Brown and Foskett sprinklers,
 21, 363.
 Buel, James, sprinkler, 363.
 Buell alarm valve, 139.
 Buell, Charles E., sprinklers, 23,
 46, 363.
 Bulb-root sprinkler (Kane), 51,
 399.
 Burritt, A. M., sprinklers, 27,
 366.
- C.
- Care of valves, 290.
 Carey, John, automatic system,
 11.
 Carpenter alarm valve, 152.
 Cataract dry valve, 199.
 Cataract sprinklers, 367.
 Center central feed for sprink-
 lers, 107.
 Centrifugal pumps, 133.
 Champion Coated Paper Co.
 fire of 1913, 308.
 Charging, Sypho Chemical sys-
 tem, 349.
 Check valve, description of, 111.
 Check valve, Sypho Chemical
 system, 348.
 Check valve pits, 114.
 Check valves on tank supplies,
 112.
 Circulation in sprinkler pipes,
 96.
 Circulation of water, combined
 heat and sprinkler system,
 332.
 Clapp sprinklers, 48, 367.
 Clapp dry valve 1, 200.
 Clapp dry valve 2, 201.
 Clark, A. B., & Co. fire of 1909,
 306.
 Clark & Cooper sprinkler, 368.
 Clayton dry valve, 202.
 Clayton sprinkler, 369.
 Cocheco Manufacturing Co. fire
 of 1907, 304.
 Combined Heat and Sprinkler
 Co., 329.
 Comins sprinkler, 369.
 Conant, Hezekiah, sprinkler, 22,
 369.
 Conclusions, Sypho Chemical
 system, 351.
 Congreve, Sir William, auto-
 matic system, 12.
 Construction of sprinklers, re-
 quirements, 84.
 Converse Rubber Shoe Co. fire
 of 1911, 307.
 Cook sprinkler, *see* Kersteter.

- Corrosion of perforated pipe systems, 7.
Corrosion of sprinklers, 78.
Cost of alarm valves, 149.
Cost of gravity tanks, 129.
Cost of sprinkler equipments, 83.
Courtney, Dana S., fire of 1917, 308.
Cox, *see* U. T. D.
Crowder alarm valve, 154.
Crowder dry valves 1 and 2, 203.
Crowder sprinklers, 370.
Curtain boards, use of, 91.
Curved offset, combined heat and sprinkler system, 329.
- D.
- Daly sprinkler, 370.
Daniels sprinkler, 370.
Dawson, Roger, automatic system, 12.
Defective sprinklers in use, 82.
Defects found at inspections, 288.
Defects of perforated pipe systems, 6.
Defects of alarm valves, 149.
Delmage sprinkler, 40.
Delohery Hat Co. fire of 1911, 307.
Derby (Ideal) dry valve, 223.
Detector water meters, 125.
Detroit sprinkler, 370.
Disadvantages, combined heat and sprinkler system, 334.
Discharge from sprinkler heads, 76.
Distribution system, Sypheo Chemical system, 344.
Dixon dry valve, 203.
Dixon sprinklers, 371.
Dodge dry valve, 203.
Dodge sprinkler, 371.
Dorais sprinkler, 371.
Double lock sprinkler, 371.
Dowson & Taylor alarm valve, 140.
Draper sprinkler, 33, 372.
Draper-Hetherington sprinkler, 34, 373.
Drip pipes, 117.
Drip pipe, arrangement of, 120.
Drip pipes, connection to sewer, 118.
Drip pipe test, 119.
Drip valve tests, 294.
Dry system, air compressor, 191.
Dry system, auxiliary, 191.
Dry system, air-filling pipe, 189.
Dry systems, 184.
Dry systems, drainage of, 188.
Dry systems, early makes, 192.
Dry systems, National Board Rules for, 187.
Dry systems, size of, 189.
Dry systems, test pipes, 190.
Dry valve enclosures, 190.
Dry valves, examination of, 295.
Dry valves, maintenance, 187.
Dry valves, operation of, 186.
Dry valves, requirements for, 195.
Dry valves, types of, 185.
Dummy-flanged, 192.
Dynamo rooms, sprinklers in, 95.
- E.
- Eclipse sprinkler (Kane), 33, 398.
Effect of sprinklers in fires, 302.
Efficiency of alarm service, 302.
Electric pumps, 133.
Enclosure for dry valves, 190.
English alarm valve, 162.
Estes Press Building fire of 1902, 303.
Esty sprinklers, 62, 373.
Evans sprinkler, 54, 55, 376.
Evans alarm valve, 155.
Evans, Powell, 52-54.

- Evans dry valve No. 3, 204.
 Expansion, combined heat and sprinkler system, 333.
 Expansion chamber, Sypho Chemical system, 243.
 Extra sprinklers, 97.
- F.
- Factory Mutual record of loss of life in sprinklered buildings, 323.
 Factory Mutual (A. F. M.) sprinkler, 355.
 Failures from age, sprinklers, 76.
 Feed mains and risers, 107.
 Field experience, combined heat and sprinkler system, 336.
 Field experience, Sypho Chemical system, 351.
 Fire record of alarm valves, 149.
 Fire record of Factory Mutual Insurance Companies, 1887 to 1894, 73.
 Fire record of National Fire Protection Association, 300.
 Fire record of old sprinklers, 1885 to 1887, 73.
 Fire record of perforated pipe systems, 8.
 Fire record, Sypho Chemical system, 351.
 Fires, important in sprinklered risks, 302.
 Fittings, long bend, 116.
 Flanged dummy, 192.
 Floor valves, 116.
 F. M. (A. F. M.) sprinkler, *see* A. F. M.
 Foskett & Bishop, 21.
 Fowler sprinkler, 377.
 Francis system of perforated pipes, 1.
 Francis Bros. & Jollett, 53.
 Freezing, protection against in cold basements, 120.
 Freezing tests, combined heat and sprinkler system, 330.
- G.
- Gages, pressure, 119.
 Garth sprinkler, 377.
 Garrett alarm valve and sprinkler, *see* Globe.
 Garrett sprinkler, 378.
 Gas check valve, Sypho Chemical system, 347.
 General Fire Extinguisher Co., 63, 66.
 Glass cover for Grinnell sprinkler, 79.
 Glazier sprinkler, 379.
 Gleason sprinkler, 379.
 Globe alarm valve, 159-160.
 Globe dry valve A, 206.
 Globe dry valve 3, 210.
 Globe dry valve B, 208.
 Globe dry valve D, 209.
 Globe sprinkler, 380.
 Godfrey, Ambrose, automatic system, 11.
 Gorton sprinkler, 381.
 Gouzé sprinkler, 381.
 Granger, A. M., sprinkler, 29, 381.
 Gravity tanks, 127.
 Gravity tanks, sizes, 127.
 Gray and Davis system, 328.
 Gray alarm valve, 157.
 Gray dry system, 194.
 Gray dry valve 1, 211.
 Gray dry valve 2, 212.
 Gray sprinkler, 49, 382.
 Grew sprinkler, 383.
 Grinnell angle alarm valve, 139, 161.
 Grinnell alarm device, 1888, 140.
 Grinnell straightway alarm valve, 165.

- Grinnell English alarm valve 1, 162.
 Grinnell English alarm valve 2, 163.
 Grinnell English alarm valve 3, 164.
 Grinnell dry valves, 193.
 Grinnell dry valve 1 (Bellows), 213.
 Grinnell dry valve No. 12 (differential), 214.
 Grinnell dry valve *C*, 219.
 Grinnell dry valve straightway *A*, 216.
 Grinnell dry valve straightway *B*, 217.
 Grinnell, Frederick, ix, 37.
 Grinnell sprinklers, cover for, 79.
 Grinnell sprinklers, glass disc, 385.
 Grinnell sprinklers, later types, 63.
 Grinnell sprinklers, metal disc, 39, 64, 383.
 Grinnell sprinklers, picker trunk, 385.
 Grinnell system of perforated pipes, 4.
 Grover, R. B., fire of 1905, 304.
 Guard, sprinkler, 312.
 Gunn sprinkler, 386.
- H.
- Hall system of perforated pipes, 4.
 Hand-hose connections to sprinkler pipes, 98.
 Hangers for pipes, 116.
 Hanging of stock on sprinkler pipes, 97.
 Harkness sprinklers, 51, 386.
 Harkness Tee, 166.
 Harris, A. C., sprinklers 1, 2 and 3, 31, 388.
 Harrison, A. Stewart, automatic sprinkler, 13, 388.
 Harrison sprinkler, desirable features, 14.
 Harrison sprinkler, defects, 15.
 Harrison sprinkler, installation system, 15.
 Heating properties, combined heat and sprinkler system, 331.
 Heating system combined with sprinkler system, 326.
 Heath sprinkler, 389.
 Herald Publishing Co. fire of 1910, 306.
 Hersey detector meter, 126.
 Hibbard alarm valve, 143.
 Hibbard dry valve 1, 220.
 Hibbard dry valve 2, 221.
 Hibbard dry valves 3 and 4, 222.
 Hibbard sprinklers, 49, 389.
 Hibbard sprinklers, causes of failure, 50.
 Higgins dry valve, 222.
 High-test sprinklers, 81.
 High-test sprinklers, rules for, 82.
 Hill sprinkler, 48, 393.
 Historical sketch of alarm valves, 139.
 Hoffman sprinkler, 393.
 Holland sprinklers, 394.
 Horack sprinkler, 394.
 Hose, hand, on sprinkler pipes, 98.
 Hoxie sprinkler, 394.
 Hub (Whiting) sprinkler, 28.
 Hunt alarm valve, 168.
 Hydraulic injector, 121.
- I.
- Ideal dry valve 1 (Derby), 223.
 Ideal dry valves 2 and 3 (Derby), 223.
 Ideal dry valve "Ever ready," 223.

Ideal sprinkler, 394.
 Independent dry valve, 223.
 Independent sprinkler, 395.
 Injector, hydraulic, 121.
 Inspection by Assured, 290, 439.
 Inspection by Bureaus, 289.
 Inspection by installing companies, 289.
 Inspection methods in use, 289.
 Inspection, self, 299.
 Installation rules for alarm valves, 143.
 Installation rules for sprinklers, 88.
 Installation of sprinklers, general information, 88.
 Installation, Sypho Chemical system, 350.
 Installations, combined heat and sprinkler systems, 336.
 Insulation of sprinklers, combined heat and sprinkler system, 327.
 International alarm valve, 142, 168.
 International dry valves 3 and 4, 226.
 International dry valve, differential, 224.
 International dry valve, mechanical, 225.
 International sprinklers, 52, 396.
 International Sprinkler Co., 52.

J.

Jahn sprinkler, 397.
 Jordan sprinkler, 397.

K.

Kane dry valve, 229.
 Kane, John, Fire Extinguisher Co., 52.
 Kane, John, sprinklers, 399.

Kane, John, Universal sprinkler, 399.
 Kane, John and William, cartridge sprinkler, 32.
 Kane sprinklers 3 and 4, 52, 400.
 Kane sprinkler, Bulb root, 51, 399.
 Kane sprinkler, Eclipse, 33, 398.
 Kane, William, Fire Extinguisher Co., 32.
 Kane, William, sprinklers, 398.
 Kane, William, sprinkler, Perfection, 369.
 Kellogg Makay-Cameron Co., 53.
 Kersteter dry valve 1, 229.
 Kersteter dry valve 2, 231.
 Kersteter sprinklers, 55, 401.

L.

Laconia sprinkler, *see* Vogel.
 Langford sprinkler, 402.
 Lapham sprinklers, 402.
 Leakage (*see* Sprinkler leakage), 310.
 Leakage from sprinklers, Factory Mutuals data, 72.
 Life, loss of, in sprinklered plants, 323.
 Linn dry valve, 231.
 Locks and canals on the Merrimack River, Proprietors of, 1.
 Long, Thomas, Co. fire, 351.
 Long bend fittings, 116.
 Loss of life in sprinklered plants, 323.
 Lynde sprinkler, 404.

M.

Macbay, William, automatic system, 12.
 Macdaniel sprinkler, 404.
 Mackey dry system, 193, 232.

- Mackey sprinkler 1, 36, 404.
 Mackey sprinkler links, 37.
 Mackey sprinkler 2, 56, 404.
 Mackey sprinklers 3 and 4, 56, 405.
 Maintenance, Sypho Chemical system, 350.
 Maintenance of sprinkler systems, 288.
 Mellers, Allen & Frazer, 50.
 Manufacturers alarm valve, 171.
 Manufacturers' Building fire of 1914, 308.
 Manufacturers dry valve, "Wood" type, 232.
 Manufacturers dry valve 3, 236.
 Manufacturers or Venturi alarm valve, 171.
 Manufacturers sprinklers, 57, 405.
 Martin sprinkler, 406.
 Mascot sprinkler, 43, 409.
 Mayall sprinkler, 409.
 McLauthlin sprinkler, 409.
 Meehan, J. C., automatic steam sprinkler, 13.
 Meloon alarm valve, 139.
 Merchant and Evans Co., 55.
 Meters, 124.
 Miller sprinkler, 40, 410.
 Montgomery sprinkler, *see* Star.
 Montgomery, W. T., 47.
 Morris sprinkler, 410.
 Morrison sprinklers, 410.
 Mutual system of tags, 293.
- N.
- Nagle dry valve, 237.
 Nagle sprinkler 1, 44, 411.
 National Board rules for alarm valves, 146.
 National Board rules for dry systems, 187.
 National Board rules for supervisory systems, 260.
 National Fire Extinguisher Co., 50.
 Naylor sprinkler, 412.
 Neracher dry valves 1 and 2, 239.
 Neracher sprinklers, 58, 412.
 Neu alarm valve, 139, 179.
 Newton, Robert, sprinkler, 59, 416.
 Newton sprinkler (England), 417.
 New York & New Haven dry valve, 240.
 New York & New Haven sprinklers, 59, 415.
 New York Automatic Sprinkler Co. dry valve, 239.
 New York sprinkler, 415.
 Niagara alarm valve, 179.
 Niagara B sprinkler, 419.
 Niagara dry valve 1, 242.
 Niagara dry valve 2, 244.
 Niagara dry valve 3, 245.
 Niagara dry valves 4 and 5, 247.
 Niagara dry valve 6, 248.
 Niagara dry valves 7 and 8, 250.
 Niagara Fire Extinguisher Co., 50.
 Niagara-Hibbard sprinkler, 417.
 Nyasco dry valve, 239.
- O.
- Offsets, combined heat and sprinkler system, 328.
 Operation of perforated pipe systems, 6.
 Orifice, size of, in sprinklers, 75.
 Ovens for testing sprinklers, 297.
- P.
- Painting of sprinklers, 80.
 Panther Rubber Co. fire of 1917, 309.

- Parks offset, 330.
 Parmelee, Henry S., ix, 16.
 Parmelee Piano Factory, combined heat and sprinkler system, 326.
 Parmelee alarm valve, 21.
 Parmelee sprinkler A, 16.
 Parmelee sprinkler 1, 17, 420.
 Parmelee sprinklers 2 and 3, 18, 420.
 Parmelee sprinklers 4 and 5, 19, 420.
 Parmelee tree system of piping, 20.
 Perfection sprinkler (Kane), 399.
 Perforated pipes, corrosion of, 7.
 Perforated pipes, defects of, 6.
 Perforated pipes, fire record of, 8.
 Perforated pipes, Francis system, 1.
 Perforated pipes, Grinnell system, 4.
 Perforated pipes, Hall system, 4.
 Perforated pipes, operation of, 6.
 Perforated pipes, pipe scheme, 5.
 Perforated pipes, Providence Steam & Gas Pipe Co., 2.
 Perforated pipes, supplies for, 6.
 Perforated pipes, Whiting system, 4.
 Phelps Publishing Co. fire of 1907, 306.
 Phelps sprinkler, 421.
 Phenix sprinkler, 421.
 Phenix alarm valve, 168.
 Phenix dry valve 1, 252.
 Phenix dry valve 2, 253.
 Phenix sprinkler, 60, 422.
 Picker trunk Grinnell sprinkler, 385.
 Pierce Bros., Ltd., combined heat and sprinkler system, 326.
 Pierce-Hammond Co., 328.
 Pierce sprinkler, 60, 423.
 Piling of stock, 97.
 Pipe hangers, 116.
 Pipe schemes, 113.
 Pipe schemes for perforated pipes, 5.
 Pipes, test, 117.
 Pipe sizes for blind attics, 106.
 Pipe sizes for sprinkler systems, 104.
 Pipe sizes 1-3-6 or P. G. & S. P. schedule, 104.
 Pipe sizes 1-2-4 or 1896 schedule, 104.
 Pipe sizes 1-2-3 or 1905 schedule, 105.
 Pipe, underground, 134.
 Pitch roofs, sprinklers in, 89, 94, 103.
 Pits for check valves, 114.
 Policy form for sprinkler leakage, 316.
 Porter Screen Co. fire of 1900, 303.
 Post indicator valves, location, 110, 114.
 Pratt, Philip W., automatic system, 13.
 Prentiss, F. H., 33.
 Prentiss sprinkler, *see* Draper.
 Pressure gages, 119.
 Pressure needed on top line of sprinklers, 122.
 Pressure tanks, 129.
 Pressure tanks, pressure required, 130.
 Protection against freezing in cold basements, 120.
 Protection to life, sprinklers as a, 322.
 Protectus meter, 127.
 Providence Steam & Gas Pipe Co., perforated pipes, 2.
 Pumps, centrifugal, 133.

- Pumps, electric, 133.
 Pumps, rotary, 132.
 Pumps, steam, 131.
 Pumps, tests of, 295.
- R.
- Report blank for inspection by Assured, 439.
 Report blank for sprinkler leakage, 313.
 Requirements for construction of sprinklers, 84.
 Requirements for designing alarm valves, 145.
 Requirements for designing dry valves, 195.
 Rhode Island Supply and Engineering Co., 53.
 Richmond dry valve, 253.
 Risks in which sprinklers are at a disadvantage, 92.
 Rockingham Paper Co. fire of 1912, 307.
 Rockwood offset, 330.
 Rockwood alarm valve *B*, 183.
 Rockwood alarm valves 1 and *A*, 180.
 Rockwood dry valves 1 and *A*, 253.
 Rockwood sprinklers, 60, 423.
 Rockwood Sprinkler Co., 61.
 Rotary pumps, 132.
 Rotating deflectors of sprinklers, 80.
 Roughton, Louis, automatic system, 12.
 Rundle Spence sprinkler, 424.
 Ruthenburg sprinkler, 37, 425.
- S.
- Sealed sprinkler, definition, 15.
 Self-inspection blank, 300.
 Self-inspection of fire appliances, 299.
 Sensitive sprinkler, definition, 15.
 Service connections from sprinkler pipes, 96.
 Shaw dry valve, 255.
 Shaw sprinkler, 45, 426.
 Shove Mills fire of 1907, 306.
 Show windows, combined heat and sprinkler system, 336.
 Shut-off valve, Sypho Chemical system, 348.
 Side central feed for sprinklers, 107.
 Simmons sprinkler, 426.
 Simplex sprinkler, 426.
 Smith, James, automatic system, 12.
 Smith, Darius, sprinkler, 426.
 Solder, sprinkler, 71.
 Souther, John, automatic steam system, 13.
 Spacing of sprinklers, 98:
 Spacing of sprinklers, joisted construction, 101.
 Spacing of sprinklers, mill construction, 99.
 Spacing of sprinklers under pitch roof, 103.
 Spacing of sprinklers under fire-proof construction, 103.
 Specifications for sprinkler tests, 85.
 Sprinkler guard, 312.
 Sprinkler heads for Sypho Chemical system, 345.
 Sprinkler leakage, causes for loss, 311.
 Sprinkler leakage, defective sprinklers, 311.
 Sprinkler leakage policy, 316.
 Sprinkler leakage report blank, 313.
 Sprinkler orifice, 75.
 Sprinkler pipes, hanging stock on, 97.

- Sprinkler pipes, circulation in, 96.
- Sprinkler pipes, connections from, 96.
- Sprinkler pipes, hose connections to, 98.
- Sprinkler pipe sizes, 104.
- Sprinkler risers, 109.
- Sprinkler solder, 71.
- Sprinkler spacing, 98.
- Sprinkler spacing under fire-proof construction, 103.
- Sprinkler spacing under joisted construction, 101.
- Sprinkler spacing under mill construction, 99.
- Sprinkler spacing under pitch roof, 103.
- Sprinkler supervisory, description of devices, 266.
- Sprinkler supervisory, gate valve attachment, 276.
- Sprinkler supervisory, limitations, 265.
- Sprinkler supervisory, National Board rules, 260.
- Sprinkler supervisory, pressure indicator, 280.
- Sprinkler supervisory, temperature device, 285.
- Sprinkler supervisory, water flow, 266.
- Sprinkler supervisory, water level device, 283.
- Sprinkler systems, test of, 295.
- Sprinkler tests, Mutual, 1884, 67; 1886, 73.
- Sprinklers, age limit, 78.
- Sprinklers, approved list, 74.
- Sprinklers as a protection to life, 322.
- Sprinklers, at a disadvantage in certain risks, 92.
- Sprinklers, coating for, 79.
- Sprinklers, corrosion of, 78.
- Sprinklers, cost of equipments, 83.
- Sprinklers, defective in use, 82.
- Sprinklers, discharge from, 70, 76.
- Sprinklers, distance from ceiling, 94.
- Sprinklers, effect of, 302.
- Sprinklers, failures from age, 76.
- Sprinklers, fire record of old types, 73.
- Sprinklers, high test, 81.
- Sprinklers, in dynamo rooms, 95.
- Sprinklers, in vertical shafts, 96.
- Sprinklers, installation, general information, 88.
- Sprinklers, leakage from, 72.
- Sprinklers, location of, 93.
- Sprinklers, number operating in fires, 301.
- Sprinklers, painting of, 80, 96.
- Sprinklers, requirements for construction, 84.
- Sprinklers, rotating deflectors, 80.
- Sprinklers, size of orifice, 75.
- Sprinklers, spacing of, 98.
- Sprinklers, tests for acceptance, 83.
- Sprinklers, test specifications, 85.
- Sprinklers, testing oven, 297.
- Sprinklers, tests of, 297-438.
- Sprinklers, types of, 42.
- Sprinklers, under peak roofs, 94, 103.
- Sprinklers, unsuitable risks for, 92.
- Sprinklers, valve discs, 81.
- Sprinklers, water supplies for, 121.
- Sprinklers, Woodbury tests, 67.
- Standard sprinkler, 427.

- Standard (Whiting) sprinkler, 28.
- Standard Fire Extinguisher Co., 53.
- Standard Report Blank Inspection by Assured, 439.
- Stantial sprinkler, 427.
- Star sprinkler, 47, 428.
- Steam pumps, 131.
- Steamer connections, 134.
- Steck dry valves 1 and 2, 256.
- Steck sprinkler, 428.
- Sterling Comb Co. fire of 1903, 304.
- Straight offset, combined heat and sprinkler system, 320.
- Stratton sprinkler, 428.
- Summary of recent tests on sprinklers, 438.
- Supervisory, *see* Sprinkler supervisory.
- Supplies for perforated pipe systems, 6.
- Swan sprinkler, 429.
- Sypho Chemical sprinkler system, description, 340.
- T.
- Tags for valves, 292.
- Tags, Mutual system, 293.
- Talcott sprinkler, 429.
- Tank, Sypho Chemical system, 342.
- Tanks, concrete, 128.
- Tanks, examination of, 295.
- Tanks, gravity, 127.
- Tanks, pressure, 129.
- Tessier sprinkler, 430.
- Tests and examinations, Sypho Chemical system, 350.
- Tests for acceptance, 83.
- Tests of temperature, combined heat and sprinkler system, 330.
- Tests for alarm valves, 295.
- Tests of drip valves, 294.
- Tests of sprinkler heads from the field, 297.
- Test on sprinklers, 438.
- Test pipe, 117.
- Test specifications for sprinklers, 85.
- Thompson, E. L., alarm valve, 143.
- Titan sprinklers, 430.
- Turner & Gardiner sprinkler, 431.
- U.
- Underground pipe and fittings, 135.
- Underground pipe, sizes needed, 136.
- Underground pipe, weight, 135.
- Underground pipe tests, 136.
- United States sprinkler, 431.
- Universal Automatic Fire Extinguisher Co., 32.
- Universal sprinkler (Kane), 399, 431.
- Unsatisfactory sprinkler fires, 301.
- U. T. D. dry valve, 256.
- U. T. D. sprinkler, 432.
- V.
- Valve discs of sprinklers, 81
- Valves and fittings, 109.
- Valves, alarm, *see* Alarm.
- Valves, arrangement of gate and check, 111.
- Valves, care of, 290.
- Valves, check, 111.
- Valves, for each floor, 116.
- Valves, post, location, 114.
- Valves, sealing or strapping of, 290.
- Valves, tags, 292.
- Valves, test of drip, 294.

- Venturi alarm valve, 142, 171.
 Venturi alarm valve *B*, 175.
 Venturi alarm valve 3 *D*, 176.
 Vogel sprinkler, 432.
- W.
- Walworth alarm valve, 183.
 Walworth dry valve 3, 259.
 Walworth dry system, 194.
 Walworth dry valve 1, 257.
 Walworth dry valve 2, 258.
 Walworth links, 36.
 Walworth Manufacturing Co.,
 35.
 Walworth sprinkler 1, 35, 433.
 Walworth sprinklers 2 and 3, 36,
 433.
 Walworth sprinklers, late types,
 61, 434.
 Warren Manufacturing Co. fire
 of 1895, 303.
 Water column of dry valves, 185.
 Water hammer, 124.
 Water meters, 124.
 Water pressure needed on top
 line, 122.
 Water supplies for sprinklers,
 121.
 Waterworks supply, 123.
- Waterworks supply, size of pipe,
 123.
 Weston sprinkler, 436.
 Whiting sprinkler (Standard),
 28.
 Whiting sprinkler (Hub), 28, 436.
 Whiting system of perforated
 pipes, 4.
 Wilber sprinkler, 436.
 Wilson sprinkler, 437.
 Witter sprinklers, 437.
 Wood dry valve (Manufacturers),
 232.
 Wood sprinklers, 437.
 Woodbury Shoe Co. fire of 1915,
 308.
 Woodbury tests, 1885, 73.
 Woodbury tests, 1884, conclu-
 sions, 67.
 Woodbury tests, 1884, distribu-
 tion, 70.
 Woodbury tests, 1884, discharge,
 70.
 Woodbury tests, 1884, sensitive-
 ness, 68.
 Worcester Bleach & Dye Works
 fire of 1910, 306.
 Worcester Fire Extinguisher Co.,
 61.

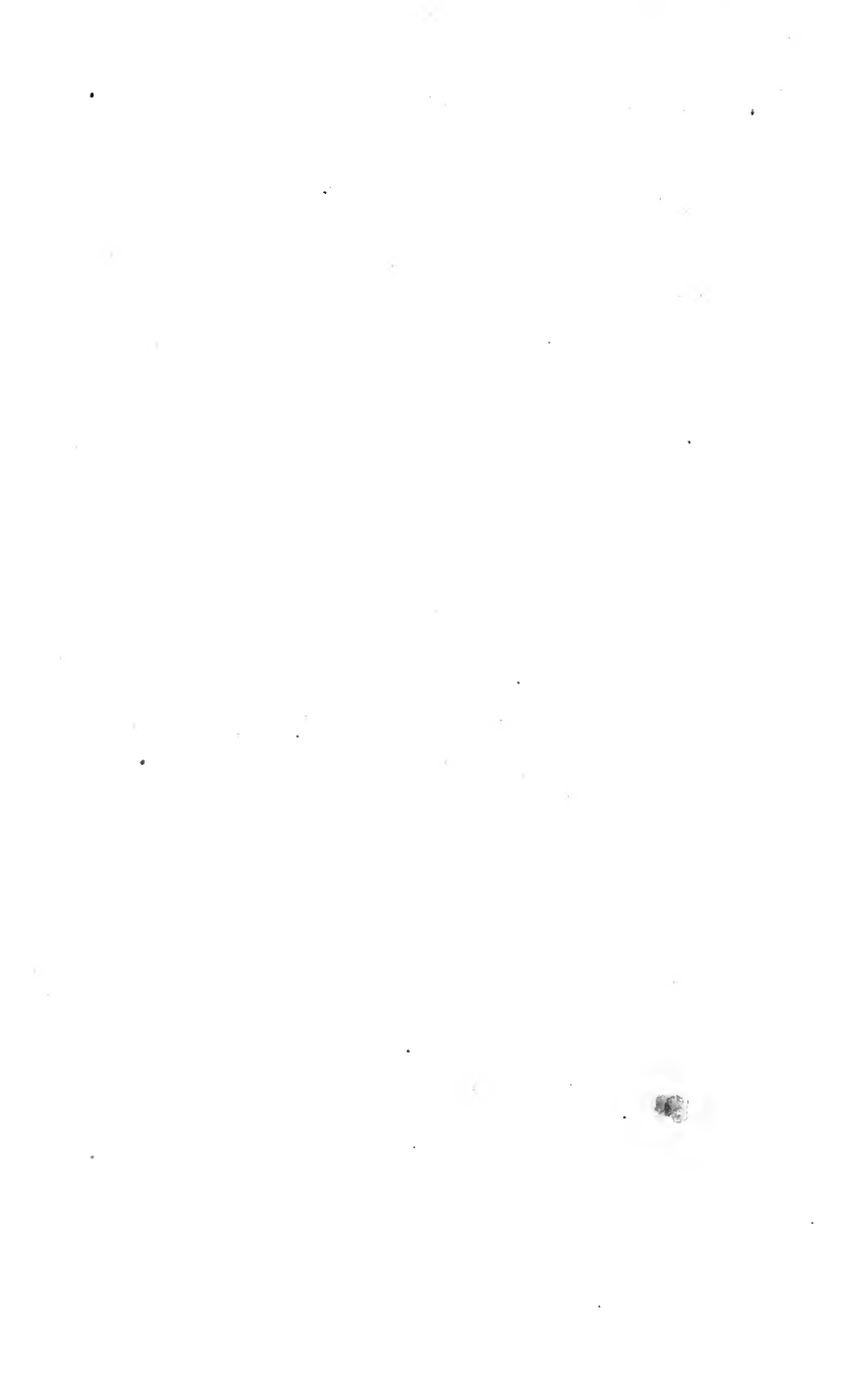



RETURN TO the circulation desk of any
University of California Library

or to the

NORTHERN REGIONAL LIBRARY FACILITY
Bldg. 400, Richmond Field Station
University of California
Richmond, CA 94804-4698

ALL BOOKS MAY BE RECALLED AFTER 7 DAYS
2-month loans may be renewed by calling
(510) 642-6753
1-year loans may be recharged by bringing books
to NRLF
Renewals and recharges may be made 4 days
prior to due date

DUE AS STAMPED BELOW

MAY 16 1996

June 12
350

T H 9336

D 3
19 19

405427

UNIVERSITY OF CALIFORNIA LIBRARY

