

UC-NRLF



QB 33 032

AUTOMOBILE TROUBLES
AND
HOW TO REMEDY THEM



EX LIBRIS

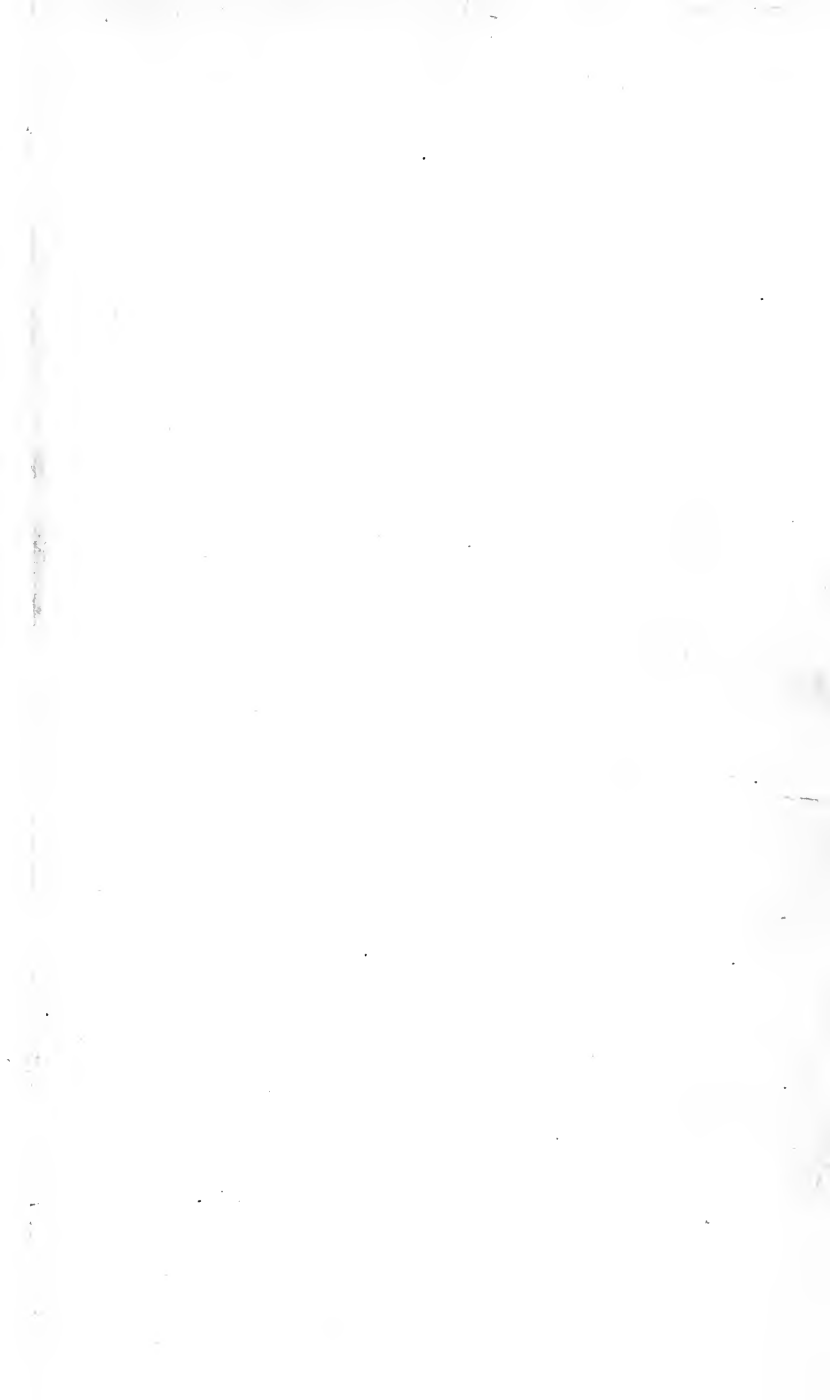

AUTOMOBILE TROUBLES

AND

HOW TO REMEDY THEM

A practical book for the Automobile Owner,
Operator, Dealer, Builder, Salesman,
Experimenter and Student of Mech-
anical Achievements.

REVISED EDITION

—BY—

CHARLES P. ROOT

Former Editor of "Motor Age."



1911—1912

THE CHARLES C. THOMPSON COMPANY

CHICAGO, U. S. A.

T 2208

K 7

1911

Copyright 1911, by
CHARLES C. THOMPSON CO.
CHICAGO, U.S.A.

AUTOMOBILE TROUBLES
Copyright, MCMIX
By THE CHARLES C. THOMPSON CO.
(Not Inc.)

CONTENTS

SYMPTOMS AND CAUSES OF TROUBLES	8
BACK FIRING, CAUSES AND REMEDY	27
BLOW BACKS	32
CARBURATION TROUBLES	35
COMPRESSION	51
CYLINDER TROUBLES	56
IGNITION TROUBLES	60
KNOCKS IN CYLINDER OR GEARINGS	95
LUBRICATION	100
MUFFLER TROUBLES	106
PISTON TROUBLES	114
LOSS OF POWER	118
STARTING TROUBLES	124
TIRE TROUBLES	132
VALVE TROUBLES	150
WATER CIRCULATION	154
NON-FREEZING MIXTURES	166
STARTING ON THE SWITCH	171
NOISE FROM TRANSMISSION GEARS	176
TIMER TROUBLE AND REMEDY	177
TROUBLE WITH VALVE TAPPETS	180
ENGINE HARD TO START	186
OVERHAUL AND REPAIR OF CAR	199

AUTOMOBILE TROUBLES.

In case of trouble with the engine or other essential parts of a motor car it is important to learn as soon as possible the exact nature of the trouble. Diagnosis is at times difficult, and requires experience, because in many cases there may be quite a number of symptoms for a failure, and the same symptoms may be common to many failures. To assist beginners, therefore, in their diagnosis, two tables have been drawn up. In one the various "Symptoms" of failure, with their "Causes," are set down in parallel columns. The other is arranged in three columns: in column I are set down the various "Failures" in alphabetical order; next come the "Symptoms," and after that the "Causes."

For example, if the engine stops, the beginner will save much time by looking up "Stoppage of Engine" in Table I. He will find the probable causes set out, and having thus got the key, will find further on in these pages full directions for putting matters right.

On the other hand, if he thinks he knows what the failure is, he can turn to Table II. The "Symptoms" in the second column will confirm him in his belief, or otherwise, and the "Causes," as before, will assist him in putting matters right. For example the driver finds when trying to start that there is no compression. He turns, therefore, to "Compression, None," in Table II, and there finds the causes, which are dealt with more fully in the articles which follow.

Before discussing in detail the possible roadside failures, we have one word of advice to offer. If the engine stops, or be-

gins to run sluggishly, much time may often be saved by trying one or two vital points before making a systematic diagnosis. For example, flood the carbureter to make sure that the feed is all right, try the engine for overheating, and then make a hasty examination of the wire connections. If one is loose, the trouble is located without a moment's delay. Failing that, test the battery. If two are carried, both being wired up with a two-way switch, switch on the second, and if the car runs all right, it may be taken that the battery was at fault. Failing the battery, try the spark plug and the contact maker or breaker. If all these are in order, it is better then to proceed on a systematic examination.

It is always advisable, after regulating or adjusting any particular part, to try if the car will then run satisfactorily. If a number of adjustments are made, one after another, and the engine is then started and is found to be all right, the operator is no wiser as to the actual cause of the trouble, and his experience is not increased. If, however, he tests the car after each operation, he locates the exact source of the trouble, and consequently, when it next occurs, the symptoms are familiar, and he can locate the trouble at once.

Would-be automobilists must not be alarmed at the length of this work on troubles and their remedies and conclude that the number of possible defects and troubles is enormous. The system of diagnosis which we have adopted necessitates much repetition if it is to prove effective in enabling a driver who is in trouble to locate at once the source of that trouble. If a plain list were made of all the possible roadside failures it would not run to alarming dimensions. It must also be borne in mind that we deal with possible, not probable, failures, and no one motorist is ever likely to meet with more than a small proportion of those dealt with.

As it often happens that failures to start are due to some neglect on the part of the driver, we should advise him to carefully study the starting directions given by each maker of motor cars, wherein he will set forth the general course which has to be followed in starting a car.

It is advisable to examine the whole car immediately after a run, as little failures are then fresh in the mind. Batteries might be tested, tires examined, and the contents of the tanks noted. It is wise to leave the car in perfect running order, as the succeeding trip may have to be undertaken hurriedly.

For convenience of reference, the articles following the tables are arranged in alphabetical order. This, needless to say, does not represent the order of their importance or the direction in which trouble should first be looked for in case of faulty running or stoppage. Under such circumstances the most likely source of the trouble will be found under the following heads, which we have arranged in order of importance:

- | | |
|-----------------------|-----------------|
| 1. Ignition. | 6. Overheating. |
| 2. Carburation. | 7. Knock. |
| 3. Compression. | 8. Timing. |
| 4. Lubrication. | 9. Valves. |
| 5. Water Circulation. | |
- Handwritten note:* H.S.P. P.12

TABLE I.—SYMPTOMS AND CAUSES.

SYMPTOMS.	CAUSES.
BACK OR TOO EARLY FIRING (PREIGNITION)	Premature firing due to ignition advanced too far, timing wrong; engine overheated.—Excessive lubrication, causing a deposit which becomes incandescent.—Overheating due to some failure in the cooling system.—Misfiring.—Switching off before throttling off.
BLOW-BACK OF GAS INTO CARBURER. POPPING NOISES	Pitted inlet valve.—Grit under inlet valve.—Broken inlet valve.—Inlet valve stuck up.—Broken or defective inlet valve spring.—Bad carburation, with ignition too much retarded.—Faulty timing.
BUZZ IN COIL (OTHER THAN CONTACT BREAKER BUZZ)	Short circuit in coil winding or connections.
CLATTER AND GRIND IN GEAR BOX.	Gear wheels loose or worn.—Broken gear wheel.—Wear in operating lever and link joints.—Bearings loose or worn.—Ball broken in bearing.
COMPRESSION, FAULTY.	Leakage from combustion chamber. (See "Compression—Faulty," in Table II.)
COMPRESSION, NONE.	Breakage of valves, piston or cylinder.
ENGINE RUNS AFTER CURRENT SWITCHED OFF	Overheating.—Short circuit.—Switch defective.—Deposit of burnt oil, which becomes incandescent.
EXPLOSIONS	Short circuits.—Misfires.—Battery exhausted.—Sooted or faulty plug.—One cylinder not working.—Bad carburation.—Pitting or wrong adjustment of coil trembler.
IRREGULAR OR UNCERTAIN RUNNING	Ignition—Intermittent short circuits.—Exhausted battery recovering after halt.—Wires broken inside insulation, with ends touching.—Contact maker disk grooved or worn.—Contact blades worn.—Particles of metal embedded in disk. Carburation—Dirt or water in carbureter.—Supply pipe partially choked.—Filter choked.—Jet in-

SYMPTOMS.	CAUSES.
<p>KNOCK</p>	<p>termittently choked by floating particles of foreign matter.—Air-hole in gravity feed tank stopped or partially stopped.</p> <p>Intermittent lubrication—Failure of pump or belt.</p> <p>... Ignition advanced too much.—Faulty timing.—Premature ignition from sooty deposit becoming incandescent.—Short circuit in contact-maker.—Overheated engine.—Want of lubrication.—Unsuitable oil.—Something loose or broken.—Connecting rod bearings worn.—Loose or worn piston pin.—Governor weights becoming loose, or arms of same touching some portion of engine.—Water in cylinder.—Loose fly-wheel.—White metal lining of bearings melted out.</p>
<p>KNOCK IN BEARINGS GENERALLY OR IN TRANSMISSION SYSTEM</p>	<p>Worn or loose bearings.—Bolts of gear case loose.—Joints of universal-jointed shaft loose or worn.</p>
<p>LEAKS: LOSS OF WATER, GASOLINE, OIL, OR AIR</p>	<p>Broken pipes, bad joints.—Weak springs to valves. (See "Leaks," Table II.)</p>
<p>LOSS OF POWER CAUSING SLUGGISH RUNNING</p>	<p>Ignition.—Short circuits.—Battery exhausted.—Coil defective.—Timing wrong.—Sparking plug defective.—Ends of plug wires too far apart or too close.—Contact maker disk grooved or worn.—Contact blades worn, bent, or not making proper contact.—Fiber disk worn.—Distributor dirty or worn.</p> <p>Carburation.—Dirt or water in carbureter.—Float punctured.—Float too light, or lop-sided.—Supply pipe choked or of insufficient bore.—Jet choked, frozen, or of insufficient bore.—Filters choked.—Stale gasoline.—Needle valve spindle bent or worn.—Leak of pressure. Pressure valve not set properly, or sticking (in the case of pressure feed).—Vacuum in supply tank through closing of air inlet (in case of gravity feed).</p> <p>Valves.—Dirty or pitted.—Springs too weak.—Tim-</p>

SYMPTOMS.	CAUSES.
	<p>ing wrong.—Valve stem bent.—Valve stem too long or too short.—Dirt under seating.</p> <p>Bad Circulation.—Air lock.—Steam bound.—Pump out of order.</p> <p>Bad Compression.—Excessive lubrication.—Want of lubrication.—Overheating.—Piston rings defective.—Clutch slipping.—Muffler choked through over-lubrication.</p>
METALLIC OR PUFFING NOISES ...	Joint in exhaust pipe loose or faulty.—Failure of muffler.—Escape of compression at valves, plugs, igniters, or rocking levers.
MISFIRES ...	For causes see "Misfires," Table II.
NOISE ...	For causes see "Noise," Table II.
OVERHEATING	For causes see "Overheating," Table II.
PISTON STICKS OR SEIZES	Overheating, generally caused by faulty lubrication. (See "Overheating," in Table II.)
POPPING NOISE	See "Blow Back."
PREIGNITION	See "Back Firing."
RACING OF ENGINE	Accelerator or throttle wrongly adjusted.—Governor spring too strong.—Governor hunting.—Clutch slipping.—Sparking advanced too much, and engine too much accelerated when running on low speed.
RESISTANCE SLIGHT WHEN OPERATING STARTING HANDLE	Loss of compression. (See "Compression—Faulty," in Table II.)
SMELLS ...	Short circuits.—Misfires.—Bad carburation.—Overheating.—Over-lubrication.
START, FAILURE TO	<p>Faulty manipulation of starting handle.—Ignition or carburation lever in wrong position.</p> <p>Ignition.—Terminals dirty or pitted.—Wires shorting.—Sparking plug defective.—Battery run down.—Coil defective.—Contact dirty or contact maker out of order.—Distributor dirty.—Switch defective.</p> <p>Carburation.—Gasolene not turned on.—Wrong mixture.—Stale gasolene in carbureter.—Dirt in pipes</p>

SYMPTOMS.	CAUSES.
	<p>or carbureter.—Carbureter empty.—Jet choked.—Excessive cold.—Gasolene in tank not reaching exit.—Water in gasolene.—Throttle lever not in best position.</p> <p>Valves.—Gummy.—Springs displaced.—Spring of automatic inlet valve too strong.—Broken exhaust valve stem.—Exhaust valve stuck up.</p> <p>Bad Compression. (See “Compression—Faulty,” in Table II.)</p> <p>Governor out of order.</p>
<p>STEERING ERRATIC</p>	<p>Wheels out of alignment.—(See “Wheels,” “Steering,” Table II.)</p>
<p>STOPPAGE OF ENGINE</p>	<p>Ignition.—Battery exhausted.—Wire disconnected or broken.—Sparking plug broken.</p> <p>Carburation.—Water in gasolene.—Supply pipe choked.—Air lock in supply pipe.—Jet choked.—Carbureter filter choked.—Mixture faulty.—Gasolene not turned on.—Gasolene exhausted.—Gasolene in tank not reaching exit.</p> <p>Valves.—Broken or displaced.—Springs broken or out of place.</p> <p>Engine.—Piston seizes.—Connecting rod broken.</p>
<p>WATER ESCAPES</p>	<p>Pipes burst.—Connections loose.—Leak in pipes.—Crack in water jacket.—Leaky radiator.</p>

TABLE II.—FAILURES, THEIR SYMPTOMS AND CAUSES.

FAILURE.	SYMPTOMS.	CAUSES.
AIR LOCK ...	Circulation fails, and engine overheats.	Air in water pipes.
BACK, OR TOO EARLY FIRING (PREIGNITION)	Knocking noise.—When starting the engine it runs backward, causing starting handle to be violently thrown back, often resulting in injuries to the operator.	Premature firing due to ignition being advanced too far.—Timing wrong.—Engine overheated.—Excessive lubrication, causing a deposit which becomes incandescent.—Overheating due to failure of some part of the cooling system.
BATTERY ...	Car runs sluggishly and jerkily.—Car stops, but runs again on being restarted. — Misfires. — Explosions.	Battery exhausted.—Short circuit in battery.—Bridge piece broken.—Nuts not screwed home or corroded.—Terminals dirty.
BEARINGS ...	Knock.—Squeak.—Jar.—Shake.—Rattle.—Excessive heat.—Bearings seize.	Bearings loose, tight, worn, dry.—Worn cones.—Broken balls.—Want of lubrication.—Grit or metallic matter in bearings.
BENT AXLE	If front axle, steering will become erratic.—Whether front or back axle wheels will get out of alignment.—If back axle, grating noise and wobbly wheel.	Sudden strain or shock, due to sideslips, skidding, collision, taking a culvert at speed, driving with one wheel in a deep gutter or rut.

FAILURE.	SYMPTOMS.	CAUSES.
BLOWBACK	<p>—Tires wear badly.</p> <p>... Popping noise in carbureter or inlet pipe.—Combination of popping noise and explosion, often accompanied by flame through air pipe of carbureter.</p>	<p>Gas blown back past inlet valve through carbureter from following causes:—Pitted inlet valve.—Grit under inlet valve.—Broken inlet valve.—Broken, or defective valve spring.—Inlet valve stuck up.—Bad carburation, especially when ignition is fully retarded.—Faulty timing.—Fully retarded ignition when starting.—Back fire at starting.</p>
BRAKES	<p>... Ineffective.—Heat. — Jamming. — Car shows tendency to slew or deviate from the running line when rear brake is applied. — Pedal brake fails to act through insufficiency of clearance for pedal movement. — Failure of certain forms of brake liners. —Brakes fail to entirely come out of action when released, or may stick in the on or off position, requiring considerable effort on the lever to free.</p>	<p>Grease on drum.—Actuating rods and levers require adjustment.—One of the rear brakes acting, the other remaining inoperative through failure in compensating device.—Liners want redressing or, in the case of metal to metal liners, renewing.—Band releasing movement (spring or bell crank-lever) wants readjusting.—In the case of toggle arms, undue play at points or distortion of one or other of the arm movements.—Take-off spring weak or broken.—Circle of brake block and shoe smaller than the drum, so that the front point of block engages first.</p>
CARBURATION	<p>Engine runs slug-</p>	<p>Gasolene supply at fault, caused by</p>

FAILURE.	SYMPTOMS.	CAUSES.
	<p>gishly on level or on an up gradient, but picks up on a down grade. — Unsteady running. — Misfires. — Popping. — Explosions. — Undue smell.</p>	<p>presence of dirt in carbureter base, filters, or in feed pipe from gasolene tank; by the jet being frozen, choked, or the aperture incorrect; gasolene level too high or too low; carbureter frozen; air lock in gasolene tank; too much pressure in pressure feed tank; bent needle valve stem, and partially jammed needle valve or a leakage past same when seated; punctured float, improperly or unevenly weighted float.—Water in gasolene.—Too weak mixture.—Sluggish or partially inoperative inlet valve (in the case of an automatically operated one).—Insufficient vaporization when starting in very cold weather.—Improperly adjusted automatic air valve.—Tank empty or nearly empty.—Stale gasolene.—Insufficient supply of hot air.</p>
CHAIN BROKEN	<p>Car stops. — Harsh noises.</p>	<p>Chain too loose, too tight, or clogged with mud.—Stone or other foreign matter gets between chain and sprocket.—Broken or distorted spring causing sprockets to get out of line and chain to mount the teeth.—Lack of proper lubrication.—Sprockets or chains worn.</p>
CHANGE SPEED GEAR	<p>Change speed wheels fail to remain in mesh. — Teeth of wheels "bottoming." — General noise at gear box and loss of power through</p>	<p>Entering edges of change speed wheels becoming too rounded by excessive rubbing when speed changing.—Teeth too deeply in mesh.—Excessive play in bearings, due to wear or want of adjustment.—Clutch forks or gear shafts distorted or twisted (the latter is of rare occurrence).—</p>

FAILURE.	SYMPTOMS.	CAUSES.
CLUTCH	<p>increased friction.</p> <p>... Engine runs fast though car travels slowly, through clutch slipping. — Clutch bites fiercely or jerkily. — Will not engage or come out of engagement.</p>	<p>Actuating mechanism requiring adjustment or repair. — Gear wheels overhanging through lost motion in the connections.—Teeth broken or worn.—Gear wheels which are not in use grinding against each other.—Change speed lever or its shaft jamming or becoming strained. — Gear lever quadrant bent so as to jam or bind gear lever.</p> <p>Slipping through oil on bearing surfaces or weak spring.—Fierce or jerky through leather hard and dry, worn, or through protruding rivets.—Jammed.—Wrong adjustment.—Insufficient play for clutch pedal.—Clutch remains slightly in contact when pedal is operated through being swollen.—In case of disk clutch, want of lubricant.—Improper lubricant.</p>
COIL	<p>... Tinny or intermittent buzz at contact breaker different from usual full note. Unusual buzz inside coil.</p>	<p>Pitting of trembler contacts.—Wrong adjustment.—Loose platinums.—Trembler blade too stiff or not springy enough.—Points made of inferior alloys.—Failure of condenser.—Defect in insulation of connections.—Loose or dirty terminals.—Failure of Insulation inside coil.</p>
COMPRESSION —FAULTY	<p>Engine loses power, and very little resistance shown when starting handle is turned.—Hissing sound. — Slow to start.— Misfires. — Overheating (if</p>	<p>Escape of compressed mixture from combustion chamber from following causes:—Valve pitted.—Valve stuck in guide.—Valve spindle bent.—Valves freshly ground.—Bad joint between the seat of inlet valve and combustion chamber.—Cracks in cylinder walls.—Too thin lubricating oil.— Slots in piston rings coinciding</p>

FAILURE.	SYMPTOMS.	CAUSES.
	pressure escaping into base chamber).	with each other, or rings partly sticking in grooves.—Worn rings.—Broken rings.—Valve spindles too long or spring too weak.—Sparking plugs cracked or broken.—Gland nut loose.—Escape between core and metal.—Washer faulty.—Compression cock open or leaking. In low tension magneto ignition escape of pressure at rocking lever of igniter.
COMPRESSION —NONE	Handle turns freely.	Inlet or exhaust valve either stuck up or broken.—Cracked cylinder.—Cracked piston head.—Broken connecting rod.
C O N N E C T - I N G R O D O R C R A N K S H A F T B R O K E N	Knock in case of cranks haft.—Sudden stoppage, accompanied by loud clanging noise in cylinder and crank case.	Preignition. — Cylinders firing against each other.—Laboring on hills.—Severe shock as when clutch is let in suddenly.—Piston seizing for want of lubrication, or through stoppage of water circulation.—Brakes applied forcibly with clutch in engagement.
C O N T A C T B R E A K E R (High Tension Magneto)	Short circuit.—Weak or uneven running.	Contact blades dirty, pitted, worn, or of inferior alloy.—Blades wrongly adjusted. — Terminals dirty or loose.—Appliance generally dirty.
C O N T A C T B R E A K E R (Low Tension Magneto)	Short circuit.—Weak or uneven running.	Timing wrong, due to faulty adjustment.—Springs too weak, broken, or of uneven tension.—Deposit due to burnt oil.
C O N T A C T M A K E R ...	Sparkling at platinum points.—Misfires. — Loss of power.	Contact blades needing adjustment.—Timing wrong.—Fiber and brass segments grooved by wear.—Brass segments worn below surface of fiber, causing contact blades to jump.—Fiber worn below segments.—Bearing surface

FAILURE.	SYMPTOMS.	CAUSES.
CYLINDERS ...	Knock.—Loss of power.— Engine weakens.— Misfires.—Escape of water.	of blade worn and not making even contact.—Contact blade too stiff, or not making firm enough contact.—In roller type—spring too weak.—Presence of oil or dirt either on contact maker or between contact maker and its shaft.—Cam loose on its shaft. Crack in cylinder or water jacket.—Warped head, due to abnormal heating following on failure of the water circulation.—Porous head.—Blowholes in cylinder casting.—Scoring of cylinder by ends of a loose piston pin.
DIFFERENTIAL	Grating noise	Teeth of pinions or driving bevels stripped.—Shaft bearings want adjustment.—Road wheels require adjustment.
DISTRIBUTER	Short circuit	Particles of metal embedded in disk.—Segments worn.—Brushes worn, broken or needing adjustment.—Wet or mud in case.—Platinum points (where such are used) pitted, worn or needing adjustment.—Connections faulty.
ENGINE STOPS	Car stops	See "Stoppage of Engine" in Table
FLARE UP	Flame	Loose pipe connections.—Leaking pipes. — Flooded carbureter.—Gasolene about base of engine.—Gasolene on footboard.—Blow-back through carbureter.
GEAR ...	Difficulty in changing. — Noises.— Breakage.	Worn or loose bearings.—Gear case loosening.—Gear wheel loose. — Wear in gear-operating connections.—Broken tooth or loose nut in gear box.—Broken ball in bearing.
GOVERNOR ...	Engine races, cuts out too	Springs too strong, too weak, or broken.—Arms carrying govern-

FAILURES.	SYMPTOMS.	CAUSES.
	<p>soon or stops.—Runs alternately fast and slow, or "hunts."— Suddenly accelerates—Difficulty in keeping engine running at constant speeds.—Engine runs "dead," and picks up badly.—Loss of power.</p>	<p>ing weights sticking.—Governor "hunts."—Toggles or the sliding sleeve and grooved collar which communicates motion to the throttle operating mechanism sticking.—Backlash and bad adjustment of operating rods and mechanism.</p>
HUNTING	<p>... Uneven action of governor, causing the engine under certain circumstances to slow up and increase its speed at regular intervals.</p>	<p>Wrong adjustment of actuating links and rods.—Wrong adjustment of butterfly valve.</p>
IGNITION	<p>... Car moves sluggishly and jerkily.—Sometimes stops.—Misfires.—Smells.—Explosions.—Knock.</p>	<p>Short circuits.—Faulty sparking plug, coil, or wires, contact maker or breaker, distributor, switch, battery run down.—Timing.—Overheating.</p>
KNOCK	<p>... An unusual noise in the cylinder like a knock or tap.</p>	<p>Ignition advanced too much.—Faulty timing.—Preignition from sooty deposit becoming incandescent.—Short circuit in contact maker.—Overheated engine.—Want of lubrication.—Unsuitable oil.—Something loose or broken.—Connecting rod bearings worn.—Loose or worn piston pin.—Governor weights becoming loose or arms of same touching some portion of engine.—Water in</p>

FAILURES.	SYMPTOMS.	CAUSES.
LEAKS IN GASOLENE SUPPLY, WATER, OIL OR AIR	Rapid falling of gasolene in tank.—Failure of gasolene to reach carbureter.—Engine overheats.—Bearings hot.—Loss of power.—Sluggishness.	cylinder.—Loose flywheel.—White metal lining to bearings melted out. In gravity feed carbureters leakage in supply pipe or shaking loose of bottom cover of strainer.—In pressure feed carbureters leakage of air pressure in air pipe of exhaust, or from tank.—Leakage of water from circulation system.—Leakage of oil.—Oil relief valve not working.—Air relief valve not working.
LOSS OF POWER OR SLUGGISHNESS	Car runs sluggishly.—Slow pace.—Misfires.—Explosions.—Smells.	For causes see "Loss of Power" in Table I.
LUBRICATION	Overheating.—Car runs sluggishly.—Misfires.—Smells.—Piston sticks or seizes.—Bearings seize or become scored.—Smoke from exhaust.—Noise and heat.—Worn bearings.—Warm bearings.	Forgetfulness.—The use of bad quality or improper oil, or defective lubrication system.—Pipe choked with foreign matter.—Relief valve not working.—Spring of relief valve too weak.—Oil pump spindle sheared.—Oil pump drive broken.—Too much oil.—Derangement of drip feed device.—Particles of metal in the oil.—Unsuitable lubricant.
MISFIRES	Car runs sluggishly and jerkily.—Smells.—Explosions.—Plug sooted.—Valve stuck.	Ignition: —Short circuits in wiring, terminals, plug, switch, distributor or battery.—Battery run down.—Coil defective.—Dirty or faulty plug.—Contact maker blades not making firm contact or vibrating too slowly.—Brass segment in disk scored or worn.—Fiber swollen.—Terminals loose or dirty.

FAILURE.	SYMPTOMS.	CAUSES.
		<p>In low tension magneto ignition, contact arm wrongly adjusted.—Broken or weak spring on striker arm.—Short in igniter or wires.—Faulty switch. In h. t. magneto, short in wires or switch, contact breaker or distributor.</p> <p>Carburation:—Dirt or water in carbureter.—Insufficient charge.—Jet choked, of insufficient bore, or frozen.—Filter choked.—Stale gasolene. — Float punctured. — Valve spindle bent or worn.—Leakage of pressure, pressure valve not set properly or sticking (in the case of pressure feed).—Vacuum in supply tank through want of air inlet (in case of gravity feed).—Insufficient supply of hot air.</p>
<p>MUFFLER TROUBLES</p>	<p>Explosions. — Excessive rattle.</p>	<p>Misfires through short circuits.—Insufficiency of current or wrong adjustment of coil tremblers, etc.—Sudden switching off and on of current.—Sooted plug.—Bad carburation.—Muffler choked.—Plates inside loose.</p>
<p>NOISE</p>	<p>Noise. — Knock or Pound</p> <p>Grating noise</p> <p>Rattling noises</p> <p>Atmospheric noises.</p>	<p>Knocking due to looseness in connections of reciprocating parts and almost exclusively confined to the engine. (Dealt with fully under "Knock.")</p> <p>Insufficient lubrication.—Bad fitting.</p> <p>Small parts and connections loose.</p> <p>Bad joints in air, gas, or exhaust pipes.—Bad joints between plugs and cylinder walls.—Bad joints between valve caps and cylinders.</p>

FAILURE.	SYMPTOMS.	CAUSES.
NUTS AND BOLTS ...	Parts become loose and rattle and nuts shake off altogether.—Difficulty in removing nuts and bolts.	—Leaky compression taps or their joints. Improperly tightening.—Neglect to use grease or other lubricant in assembling.—Screwing nut or sideways.—Omission of split pins
OVERHEATING	Smell of burning.—Slight smoke.—Knock. — Car gradually slows, and finally stops. — Sometimes will fire after current turned off. — Piston seizes (rarely). —Water steams.	Defect in water circulation.—Choked or ineffective radiator.—Choked waterpipes.—Pump out of order.—Escape of water.—Air lock.—Steam bound.—Continuous hill climbing at a slow pace, especially when there is a tail wind.—Insufficient lubrication.—Unsuitable oil.—Faulty carburation.—Running continuously with one cylinder misfiring.—Laboring on hills.—Ignition retarded too much.—Running engine too fast.—Escape of compression into base chamber through defective piston rings or worn cylinders.—Escape through bad joint between seat of valve and combustion chamber.—Insufficient lift of exhaust valves.—Slipping clutch.
PIPES BURST or FRACTURED	Water escapes.—Engine overheats, and if not stopped at once piston may seize.	Water freezing. — Connections loose.—Vibration.
PINION LOOSE	Unusual noise. — Grind. — Difficulty in changing gear.—Eventual break up of gear. — Noise.—	Loosening of nuts securing gear rings.—Broken tooth or portion of tooth due to faulty changing or letting in clutch too suddenly.—Backlash in, or faulty adjustment of operating mechanism.

FAILURES.	SYMPTOMS.	CAUSES.
PINION BROKEN	Difficulty in changing. — Eventual locking of gear.	
PISTON TROUBLES	Loss of compression. — Scoring of cylinder walls.	Rings stuck with gummy deposit. — Rings worn or broken. — Slots coinciding with each other. — Rings bad fit.
	Knock. — Gradual weakening and eventual stoppage of engine.	Insufficient lubrication. — Unsuitable oil. — Overheating. — Preignition, resulting from sooty deposit and causing overheating.
POPPING IN CARBURETER	Loss of power. — Popping noise. — Flame about carbureter in some cases.	Carbureter flooded. — Carbureter starved. — Inlet valve spring weak. — Valve sticking open, opening too much or pitted. — Ignition of gas in inlet pipe. — Ignition retarded too much in combination with weak mixture. — Back fire at starting. (See "Blowback," in the following pages.)
PRESSURE LEAKING (in case of pressure feed)	Engine runs sluggishly, and stops if pressure fails altogether. Overheating.	Leakage in gasolene pipes. — Leakage at top of oil cylinder. — Pressure valve out of order or filter choked. — Oil cylinder empty. — Leakage at cap of gasolene tank. — Pressure pipe from exhaust choked.
PREMATURE OR PREIGNITION	Knock	See "Back, or Too Early Firing."
SHORT CIRCUITS	Car moves sluggishly and jerkily. — Misfires. — Explosions. — Car stops.	Loose wires. — Dirty contacts. — Bad insulation. — Battery terminals corroded, dirty, or bridge joining terminals broken. — Spanner, wet cloth or such-like across poles of battery. — Wrong adjustment or dirt in contact maker, or distributor. — Disks of same worn, grooved, fouled with thick oil, or

FAILURES.	SYMPTOMS.	CAUSES.
SPARK PLUG	Short circuits.— Misfires. — Engine stops, or won't start.	dry and gritty.—Sparkling plug broken, points too far apart, touching, or bad contact between shell of plug and metals of motor. —Moisture on porcelain of sparking plug, wires, terminals of contact maker, distributor, or on coil. —Burnt contacts.—Loose platinum on contact blades or coil tremblers.—Oil on contacts. In magneto ignition, shorts may occur in the wiring, terminals, plugs, igniters, switch, contact breaker, or distributor. Unsuitable spark plug.—Moisture on insulating core or points.—Core cracked or loose.—Points touching, or too far apart.—Points sooted.—Porcelain or mica of core sooted.—Wire loose on terminal. —Plug too long or too short.—Escape of compression at packing gland.—Oil or water on base of porcelain or between sparking points.—Bad contact between shell of plug and metal of engine.
STEAM BOUND OR AIR LOCK	Overheating.	Accumulation of steam or air in pipes and radiator which prevents free circulation.
STEERING	...Steering stiff or jerky. — Driver loses control.— Considerable backlash between steering wheel and road wheels.	Unpinned bolt drops out of steering link.—Ball of ball joint comes adrift through wear or lack of adjustment.—Link, or a steering arm breaks.—Bent steering link.—Want of lubrication.—Backlash due to wear in worm and sector. —Wear in joints of adjusting levers or in the front axle jaws or swivel pins.—Worn or loose bearings.—Steering wheels out of alignment.

FAILURES.	SYMPTOMS.	CAUSES.
SUPPLY PIPE CHOKED	Sluggish and intermittent running. — Engine stops.—Misfires.	Dirt in pipe.—Filter choked.
TIMING	... Knock.—Loss of power. — Overheating. — Irregular firing.—Harsh running.	Badly worn crankshaft and connecting rod bearings.—Preignition owing to incorrect timing of contact maker or contact breaker. —Exhaust valve out of time, or insufficient lift, due to wear of stem and tappet, or to wrong setting of camshaft gear wheel.—Mechanical inlet valve out of time, or insufficient lift.—Automatic inlet valve spring too strong or too strongly adjusted or too weak owing to fatigue.—Wear of valve cams.—Cams, or gear wheels loose on cam shaft.—Gear wheels worn, or wrongly meshed. —Valve spindle in contact with tappet owing to constant grinding.—Strained crankshaft putting crank pins out of line.—Too much "lead" given to low tension ignition gear, causing premature ignition.—Cylinders out of synchronism owing to wear in magneto tappet gear. (See "Timing," in following pages.)
TIRES	... Puncture of air tube. Boil on casing. Burst	Nails.—Pieces of metal.—Sharp stones.—Air tube nipped under bead or security bolt.—Security bolt defective or bent.—Air tube frayed by faulty patch on casing. Gradual failure of fabric due to split formed inside by flexion, or moisture penetrating neglected cut in rubber. Neglect to repair boil in time.—

FAILURES.	SYMPTOMS.	CAUSES.
VALVES	<p>Clean longitudinal cut inside casing.</p> <p>Misfires. — Sluggish running. — Explosions. — Popping. — Loss of compression. — Car stops. — Engine fails to start.</p>	<p>Security bolts not tightened.— Fabric completely worn out.</p> <p>Excessive flexion due to tires not being pumped hard enough or to faulty construction, causing uneven strain on strands of fabric in one particular spot.</p> <p>Sooty or gummy deposit.—Spindle bent or broken.—Valve pitted or warped.—Spring too strong, too weak, out of place or broken.—Springs in different cylinders of irregular tension.—Too little or too much clearance between stem and plunger.—Valve stuck.—Valve broken.</p>
VALVE SPRINGS	<p>Irregular action of valves. — Total failure. — Car stops.</p>	<p>Springs Broken. — Twisted. — Jammed. — Too strong. — Too weak.— Unequal tension in multi-cylinder engine (only in cases of automatically operated valves).</p>
WATER IN CRANK CHAMBER	<p>Water appears in oil when drawn off.</p>	<p>Leaky joints. — Porous head. — Crack in water jacket.—Water in gasolene.—Water gets in when washing car. (See "Cylinders," in the following pages.)</p>
WATER IN CARBURETER	<p>Car sluggish, sometimes stops. — Misfires. — Explosions.</p>	<p>Water condensing in tank or carbureter.—Also gets in with gasolene.—Want of care in washing or protection from rain.</p>
WATER CIRCULATION	<p>Overheating. — Sluggish running.—Steam.</p>	<p>Pump:—Defective. — Broken. — Spindle locked and friction wheel not working or slipping.—Chain broken or come off (in chain drive).—Worn washers, valves or bearings. — Swollen washers. — Grease in pump.—Frozen pump.</p> <p>Pipes:—Choked. — Broken. — Leaking.—Air bound or steam bound.</p>

FAILURES.	SYMPTOMS.	CAUSES.
WHEELS	... Wheels out of alignment. — Looseness or creak in spokes. — Faulty steering. — Tires scored transversely. — Car runs sideways. — Car steers erratically.	<p>Radiator:—Grease or other deposit. —Mud in gills.—Improper proportion between the amount of water and the cooling surface of radiator.</p> <p>Fan:—Belt slipping or breaking.</p> <p>Water Jacket:—Leaks.—Deposit.—Scale.</p> <p>Bent car axle, stub axle on which wheels revolve, steering link, or steering arms.—Spoke broken, cracked, shrunk, decayed, loose in hub.—Hub shaky.—Bearings worn or loose.—Wrong adjustment of axles in chain drive.—Axle shifted endways on springs.—Front and rear wheels out of alignment.—Springs shifted across axle.</p>

N. B.—The remedies for all the troubles indicated in the above tables are given in the series of articles which follow, the subjects being arranged in alphabetical order.

BACK FIRING.

Symptoms: When starting the engine it rotates in the opposite direction to that in which it should revolve, and causes starting handle to be violently thrown back, which possibly causes injury to the operator.—Explosions in the exhaust are sometimes known as back fires.

Causes: Wrong timing of ignition.—Preignition, due to incandescent carbon deposit.—Overheating, due to failure of some part of cooling apparatus.—Misfiring.—Switching off before throttling off.

In the majority of cases, this is caused through the ignition taking place too early. The ignition should always be retarded when starting the engine, owing to the low speed at which the crankshaft is turned in starting. In some cases, an automatic arrangement is used to insure the retarding of the ignition when the starting handle is put into engagement with the engine shaft. Where such is fitted it is not well to rely on it too implicitly as, if it becomes deranged, or if the starting handle is not pushed fully home on the crankshaft, a bad back fire may result, with possible injury to the operator. A back fire may also be caused by defective connections in the ignition wiring causing the spark to be passed at the wrong time, or by excessive overheating of the engine due to some derangement of the water circulating system, such as a lack of water, failure of the pump to act efficiently, or the fan belt coming off. Heavy deposits of carbon in the cylinder, combustion chamber, and on the head of the piston may, if the engine is allowed to become overheated, become incandescent, and will fire the charge before the end of the compression stroke. The remedy, of course, is the thorough cleansing of the cylinder and piston. This state of affairs is often due to excessive lubrication. See reference under "Overheating" and "Cylinders" in the following pages.

Popping in the carbureter, which is sometimes erroneously referred to as backfiring, is invariably accompanied by misfiring. See "Misfiring" and "Blowback" in the articles that follow.

Explosions in the exhaust pipe and muffler, often called back-fires, are, in nearly all cases, due to misfiring—the engine sucking in and expelling the charge of combustible gas through the exhaust pipes into the muffler, where it is ignited by the flame of the next exhaust stroke. See “Muffler Troubles.”

In some cases, where the engine has been allowed to stand and is restarted, firing will take place in the muffler. This may be due to switching off the current before closing the throttle. The result is that the exhaust pipes and muffler are supplied with a mixture of combustible gas, and on restarting the engine, as soon as the flames reach the exhaust pipe or muffler, they ignite these gases which have been left behind. There is no danger with a muffler explosion of this description. Four-cylinder engines can often be started again by means of the switch without turning the starting handle, provided the driver switches off before closing the throttle.

BEARINGS.

Symptoms: Grinding, grating, knocking, or squeaking noise.—Heat.—Side shake.—Bearing tight at one side and loose at another.—In extreme cases bearings will seize.

Causes: Want of lubrication.—Wear.—Want of adjustment.—Broken balls.—Grit in bearings.

Roller bearings, ball bearings, plain, and anti-friction lined gunmetal bearings are the four kinds chiefly used in motor cars.

All must be kept well lubricated, clean, and properly adjusted. Lubrication is very important, and, except for the waste of oil, too much cannot be used, except, of course, in the engine. But, in addition to this, all grit must be removed not only from the bearing itself, but also from any place from which it can reach the bearing, otherwise lubrication will not save the bearing from wearing. Plain bearings can be run in a more defective condition than either of the others, as they will not show their condition so quickly, and for this reason are not as constantly examined as they should be. If a bear-

ing shows any scores or ribs, both shaft and bearing must be refitted, but this is a job that should not be undertaken rashly, as it requires much experience to do it properly. Besides cleaning and lubricating, it is advisable to feel all the bearings occasionally to make sure that they are properly adjusted.

The bearings of a new car are apt to get hot at first, and in extreme cases may even seize. They should, therefore, be felt at frequent intervals, and, if distinctly warm, should be freely lubricated, and, if necessary, re-adjusted.

If the bearings are not properly lubricated, as already pointed out, they will wear rapidly, and probably seize. Even with the best treatment, however, there is sure to be a certain amount of wear, and it is absolutely essential that this should be taken up at once. In extreme cases the bearings may require rebushing.

Wear can be taken up in plain bearings by taking out the brasses and filing the two adjoining faces so as to make them a closer fit to the journal. In this case, however, they will have to be scraped to a true fit—a job which can only be properly carried out by an experienced fitter. Very little trouble is given by broken balls on modern cars, and, generally speaking, ball bearings will last as long as the car. Should any wear or damage occur, however, the ball bearing should be replaced with an entirely new set of races and balls. In the case of wheels, ball races which have worn unevenly will result in the wheel becoming tight in one place and slack in another. The proper remedy is a new cone or cup, as the case may be. In all cases the balls should be of exactly the same size, and it is better in replacing balls to use a complete new set, of a known make and taken from one lot, than to replace by odd balls which may be very slightly smaller or larger. If one ball is larger than the rest, even by the thousandth part of an inch, the ball races will be rapidly worn away with the hammering. To preserve plain bearings in proper condition, it is necessary that they should be kept tight and well lubricated, proper lubrication having more to do with the life of a plain bearing than any other consideration. The slightest

looseness in a bearing should be at once taken up, otherwise knocking will result, and the trouble will be rapidly increased. Engine bearings, especially crankpin bearings and piston pin bearings, should have a fair amount of side-play—1-16th of an inch side-play is not by any means too much.

In the case of gear boxes, bearings may become cut through improper changing of the gears allowing the gear wheels to grind against each other. If this occurs, particles of grit will be carried up by the lubricating oil into the bearings and rapidly cut them away. The remedy is to periodically drain away the oil from the gear box and replenish with new oil. If there is an appreciable amount of metallic grit in the oil it is advisable to examine the bearings. If they are scored they will require refitting and scraping, otherwise they will very soon show great signs of wear and allow the oil to escape.

In adjusting a cone ball bearing, as used in some motor car wheels, it is advisable to screw the cone up tight and then to screw up the lock nut hand-tight and afterward screw the cone slightly back—a quarter of a turn will be sufficient—until it jams against the lock nut, finally tightening up the lock nut and securing it with a split pin. Should this not be done, it is possible that, when tightening up the lock nut, so much pressure will be put on to the cone and balls as to cause them to break when they come into operation on the road. At the same time, they should have no appreciable shake.

The bearings in the steering gear are of special importance, and should be kept perfectly adjusted if the driver appreciates nicety of steering.

Loose bearings in any portion of the car are generally indicated by noise and rattle.

BENT AXLE.

Symptoms: Tires wear transversely.—If front axle, steering will become erratic.—If rear live axle, decided grating noise in differential bevel gear, and wobbly wheel.—Whether front or back axle, wheels will get out of alignment and give the appearance of being inclined inwards at the top.

Causes: Side-slip.—Collision.—Culvert.—Deep gutter or rut.

In the event of an accident, due to side-slip or collision with another vehicle, it is advisable to at once examine the axles. Damage to the front one is easily detected, the steering gear becoming strained or erratic in action, and the wheels appearing as though they inclined inward at the top. The condition of the rear axle is not so easy to discover. For the purpose of inspection the rear wheels should be lifted in turn, and the half axle revoived. Any ill effects as regards straining will be detected by the appearance of a "tight" spot. This test should not, however, be regarded as sufficient.

According to the nature of the accident the user can judge its probable effects. There is the danger of a bent axle (according to the nature and situation of the bend), "breaking short" subsequently at the point, so that under any circumstances any visible damage should, as soon as possible, be inspected thoroughly. For the purpose a fair sized magnifying glass will be found serviceable, and requires no trained skill to use.

Where the live part of a live axle carries a wheel at its end, bending is a serious matter, as this axle also supports the weight of the car. Wobbling of the wheel in such a case will indicate a bent axle, and the only safe remedy is to replace it with an entirely new axle. Bending it straight will only stretch the metal and probably render it brittle at a vital point, so that it may eventually break short.

Fitting an entirely new axle is a necessary precaution.

BLOW-BACK.

Symptoms: Popping in carbureter or inlet pipe.

Causes: Gas blown back into carbureter from following causes:—Pitted inlet valve.—Grit under valve.—Broken inlet valve.—Valve stuck up.—Broken or defective valve spring.—Bad carburation, especially when ignition is fully retarded.—Faulty timing.

This term is used as regards the gas, whether ignited or not, blown back through the inlet valve and inlet pipe into the carbureter, generally accompanied by a popping noise.

In those engines in which an automatic inlet valve open-

ing downward is used and the spring breaks, loses its temper, or fails to act, or the valve stem itself breaks, a blow-back may be caused in the carbureter or the inlet pipe. In such cases the derangement will be so serious as to cause the engine either to stop or to fire very intermittently. Where the inlet valve is operated mechanically, a blow-back may be caused by the valve stem bottoming on the top of the plunger instead of the valve head fitting down on its seat. In such cases the remedy is to alter the height of the valve plunger where an adjustment is provided, or to grind the end of the valve stem so as to shorten it and allow the valve to seat properly. This adjustment should be made when the engine is hot. It may sometimes require to be done after the valve has been ground in. If the valve is pitted or unduly corroded, a blow-back may be caused. The remedy is to grind it in. A mixture which is too weak will sometimes cause popping in the carbureter; wrong adjustment of the valve camshaft is another fruitful cause, due to the exhaust valve remaining open too long or to the combustion being so slow that there is actually a flame in the cylinder at the time that the suction stroke commences. The proper set of the valves is dealt with under "Overhauling."

A blow-back should not be confused with a back fire, the latter being the explosion of the charge before the piston has reached the top of its compression stroke, with the result that the direction of rotation of the engine is reversed. See Back Fire.

THE BRAKES.

Symptoms: Ineffective.—Heat.—Jamming.—Chattering.—Car shows tendency to slew or deviate from the running line when rear brakes are applied.—Pedal brake fails to act through insufficiency of clearance for pedal movement.—Failure of certain forms of brake liners.—Brakes fail to entirely "come off" when released or may stick in the on or off position, requiring considerable effort on the lever to free.

Causes: Grease on drum.—Actuating rods and levers want adjustment.—Circle of brake block or shoe smaller than circle of drum so that front point of block engages first.—One of the rear brakes acting, the other remaining inoperative through failure in com-

pensating device.—Liners want redressing, or in the case of metal to metal liners, renewing.—Band releasing movement (spring or bell crank lever) wants readjusting, and in the case of toggle arms undue play at joints, or distortion of one or other of the arm movements.—Take-off spring weak or broken.

A foot-applied, double-acting brake is usually fitted on the countershaft or propeller shaft, as the case may be, and double acting hand-applied brakes act on the back wheels. The countershaft brake is much more used than the hind wheel brakes, and there is a great tendency to depend on the former alone and risk the latter being in order. This is a most dangerous practice, and cannot be too much condemned. As a matter of fact, the hand lever brake acting on the back wheels is the one that should be used for general purposes, because it causes less strain to the car than the countershaft brake. This is especially so in the case of the propeller shaft system of transmission. The strain on the universal joints, bevel wheels, and differential bevel pinions is excessive.

It is also vital to the safety of the motorist that this brake should always be in perfect order, for should the chain (in case of chain transmission) or bevel wheel (in case of propeller shaft) break, or the differential collapse, the brake would become totally inoperative.

Before every run, both brakes should be examined and tested, and any defects at once made right. Brakes should be adjusted so that while there is no danger of their acting when not required, sufficient grip can be secured by the hand or foot lever to hold the car, with either brake, on a very steep incline. The amount of slack to be left can only be told by experience, as different types of brakes require different treatment. If, on applying the hand brake, the car shows a tendency to slew round, this indicates that one of the brakes is gripping more strongly than the other; an immediate adjustment should be made. Both brakes should grip together and evenly. An effective compensatory device should prevent this trouble, however. See that the mechanism of same is clean and well oiled, or it will not work smoothly. If a wire cable running through the brake shaft is used, keep the round-

ed tube edges where it leaves the ends of the shaft well greased. Also periodically see if the cable is fraying, and at once replace the cable on the least sign of wear.

When a brake is applied with a toggle mechanism, it is necessary to periodically examine it to see that the two short levers of the toggle have not come into line with each other, as they may do if excessive wear takes place between the shoe and the drum. As soon as they get into this position, the braking becomes inoperative. In some of the modern cars there is an adjustment provided, by means of which the toggles can be slightly lengthened if necessary. If no such adjustment is provided, it is necessary to have either the shoes or the drum relined, which can only be done by a competent mechanic. Most modern brakes employ cast-iron shoes against steel drums, and occasional lubrication is good for them. In some of the older cars leather-faced steel bands or bands faced with segments of vulcanized fiber may be found. The latter should be oiled occasionally. The former should be well dressed with clutch oil.

Too lengthy an application of the brakes in the case of leather may result in the leather burning. Once this condition has been set up, the bands must be entirely refaced with leather.

In the case of both hand and foot applied brakes it is necessary to see that the lever has plenty of room to move forward or backward—as the case may be—after the brake is on hard. Many brakes have become inoperative owing to their being so adjusted that the lever could not move far enough to operate the brake efficiently. A brake which is in constant contact with the drum will rapidly heat up. This state of affairs can generally only be ascertained after the car has been running for some time, and therefore it is advisable occasionally to feel the brake drums and shoes immediately after the car has come to rest. A brake which has this tendency may become dangerously overheated on a long, steep hill, and a serious accident might occur should it seize, especially in the case of one only of the rear brakes seizing and locking one back

wheel. Sometimes bad adjustment of the brake may be due solely to bad adjustment of the wheel bearing, especially in the case of a chain driven car, or cars having their wheels running on the outside of live axles. Should the adjustment of these be such that the wheel can tilt over on its bearing, the brake shoe will bind sideways. The remedy is to adjust the wheel bearing.

Where a metal to metal brake chatters and then goes on suddenly, it may be taken for granted that the shoes or blocks are bearing more at those ends which face the motion of the drum. The remedy is to file off the engaging surfaces of the shoes or blocks at their ends so as to form a gradual incline in front of the actual braking surfaces.

CARBURATION TROUBLES.

Symptoms: Engine runs sluggishly on level or on an up gradient, but picks up on a down grade.—Unsteady running.—Misfires.—Popping.—Undue smell.

Causes: Gasolene supply at fault, caused by presence of dirt in carbureter base, filters, or in feed pipe from gasolene tank; by the jet being frozen, choked, or the aperture incorrect; gasolene level too high or too low; carbureter frozen; air lock in gasolene tank; too much pressure in pressure feed tank; bent needle valve stem; partially jammed needle valve, or a leakage past same when seated; punctured float; improperly or unevenly weighted float.

Water in gasolene.—Too weak mixture.—Sluggish or partially inoperative inlet valve (in the case of an automatically operated one).—Insufficient vaporization when starting in very cold weather.—Improperly adjusted automatic air valve.—Tanks empty or nearly empty.—Stale gasolene.—Insufficient supply of hot air.

If the car runs fairly well at low speed, on the level, or downhill, but jibs when the work becomes heavy, it is generally an indication that the gasolene supply is at fault.

Before going into a detailed examination it is a good plan to flood the carbureter by depressing the float, and then see if the running of the car is improved for the next few yards—that is, while the gasolene in the carbureter lasts. If it is, the test is a good index that the engine is not getting sufficient feed.

The following is another useful test. Expose the jet; turn the gasolene full on; hold up the valve spindle till the carbureter floods; then jerk the spindle freely up and down by a light effort with the fingers. If the gasolene spurts freely out of the jet or nozzle, it is evident that the gasolene feed is in no wise at fault. If, however, the result of these tests is to point to a failure in the gasolene supply, it will be necessary to make a systematic examination.

If the supply pipe is partially choked, the running of the engine is, as a rule, intermittent, for a certain amount of gasolene gets through, which is sufficient to keep the carbureter full when the work is light, but not otherwise; or the obstruction may be of a movable nature, at times allowing the gasolene to pass more freely, and at times blocking it altogether. A total blockage will, of course, stop the engine. By racing the engine suddenly the increased suction will sometimes clear away the obstruction.

In the carbureter itself dirt may choke the inlet pipe about the region of the valve, or the duct leading to the jet, or the jet itself, may become choked. If dirt is suspected, it is best to begin with the carbureter. Open the aperture at the bottom, and let the contents run off. It will be easily seen if dirt is present. If this does not have the desired effect, it will be necessary to take the carbureter to pieces and clean every portion thoroughly, especially the filter, which is apt to get choked. A tiny piece of grit or other obstruction may intermittently, totally, or partially choke the jet, or the passage leading thereto, by being carried up by the flow of gasolene, and dropping back when the pressure ceases. Agitating the float will in that case be deceptive, as the jet chamber will flood all right temporarily, but when the engine is started the floating particles will get sucked into the jet. The jet should be removed, thin wire (such as is used for tying bunches of flowers) or an acetylene burner cleaner passed through it, and then washed out. Needles should not be used on account of the risk of the end breaking or the hole in the jet being enlarged, and thus upsetting the carburation.

When the supply pipe is disconnected from the carbureter, and the gasolene is turned on, it is easy to see if the flow is steady and strong; if not, the supply pipe should be disconnected from the tank and removed altogether. An ordinary tire pump should then be connected to one end and vigorously operated. This, in most cases, will blow the obstruction through. Failing that, a wire should be passed through the pipe, and to this end the pipe will have to be straightened out. It should be done cautiously, and, if there are actual loops, it may be necessary to heat it to a dull red. If that fails, the obstruction will have to be burnt out on a forge fire, a wire being used to clear away the burnt products which are left.

Neither carbureter nor supply pipe should be disconnected in the presence of any artificial light, except electric. This especially applies to the supply pipe at the tank end, for if the gasolene caught fire nothing could save the car.

In the case of a gravity fed carbureter the partial or complete stoppage of the air hole in the tank will prevent the free flow of the gasolene.

Another cause of trouble, in cases where the gasolene is pressure fed to the carbureter, is an excess of pressure in the tank, which causes the gasolene to actually lift the needle valve off its seat and flood the carbureter. This is solely due to the choking up of the pressure release valve, the object of which is to prevent the air pressure from rising beyond the determined amount. The remedy, of course, is to take down the pressure release valve, and see that it is working properly. In some cases a pressure gauge is fitted on the dashboard, showing the pressure in the gasolene tank, and if this trouble arises, it will be indicated by the increased pressure shown on the gauge.

The surface of the gasolene in the float chamber should remain at a level the least shade under the top of the spraying jet. If the float is too light it will rise too soon, shutting the valve before the gasolene is high enough, and so starving the engine. The remedy is to increase the weight slightly by adding a blob of solder, or the float may be too heavy and cause

flooding, in which case a little weight should be carefully and evenly scraped off.

In increasing the weight of the float by adding solder, it is very necessary to place the solder in such a position on the float as not to interfere with its balance. It is, therefore, better to attach two blobs of solder—one on either side of the central hole through the float—otherwise the float may tilt sideways, and jam on the needle valve, which will prevent the carbureter acting properly. To detect whether the float is evenly weighted, it should be allowed to float in a basin of water, when it may be deemed correct if it rises out of the water the same height on all sides.

Trying either a longer or shorter jet is an alternative means of correcting the gasolene level. It has this advantage, that one can experiment with jets of different lengths so as to arrive at the gasolene level which gives the best all-round results.

The float spindle, the end of which operates as a valve, may get bent, and consequently act irregularly. The float, too, may not be evenly weighted, and may consequently get temporarily jammed, which will affect the height of the gasolene in the carbureter intermittently. This, needless to say, would be an exceedingly difficult trouble to locate. The trying of a spare float would probably be the best way to deal with this trouble.

If the trouble is not in the supply of gasolene to the float chamber, there may be other causes of carburation failure.

The float chamber may be flooded, for example. This is caused either by a punctured float or too heavy a float. In the former case the float itself fills up with gasolene (the presence of which can be detected by shaking it close to one's ear), and consequently will not close the needle valve to the float chamber. The gasolene must be carefully drained out of the float and the hole soldered up. If the hole is so minute that the gasolene will not flow out it should be enlarged with a pin. If, however, the puncture cannot be located at all, the float should be sunk in water which is almost boiling. The heat

will expand the gas to such an extent as to force it through the aperture, and a flow of bubbles will indicate the spot. All the gasolene can be removed in this way, but if the motorist has a soldering kit with him, it is better to enlarge the hole and, having shaken the gasolene out, solder the hole. In rare cases the tube through the center of the float may puncture. Here the trouble is a very difficult one to locate, or to remedy.

If the float is too heavy, the gasolene will rise too high in the float chamber before the valve comes into operation. It must be lightened, but very carefully and gradually. The valve may be worn, allowing the gasolene to leak through and, consequently, flood the carbureter. The remedy is to grind the valve on its seating, but should this be ineffective, owing to the wear being deep-seated, it is then necessary to turn the valve in a lathe. The valve spindle may have been unduly shortened by successive grindings, and consequently the valve fails to act. In this case remove the needle end from the disk by heating the solder, and slide the disk the smallest fraction of an inch up the spindle. Then re-solder. Where a separate air valve is fitted it may jam in the closed position, when all the suction of the engine will be diverted to the jet, and thus cause an over-supply of spirit, resulting in too rich a mixture.

Water in gasolene is a very common source of trouble. In most cars a special trap is arranged to intercept the water, and this should be opened at frequent intervals. There is also an aperture at the bottom of the carbureter for the same purpose.

The presence of only the slightest amount of water in or about the carbureter is often sufficient to cause a stoppage. Therefore, care should be taken that the carbureter is protected from water which may leak from the circulation system, and, in washing a car, no water should be allowed to collect near the carbureter.

Occasionally a mild flare-up at starting may occur through one or other of these causes. It can only happen, however, if the carbureter has been flooded to such an extent that gaso-

lene has run about the engine, and if the inlet pipe near the carbureter is not properly protected with gauze. If a flare-up occurs, the gasolene should be turned off at once, and if the engine is running it should be let run until the gasolene in the carbureter has been exhausted. If the flare-up is really bad, sand should be dashed on the seat of the trouble. This should be carefully cleared away afterward.

The pipe which conveys the gasolene from the tank to the carbureter should be fitted with a cock in an accessible position, so that the gasolene can be turned off at once, should the carbureter overflow. This may arise through faulty seating of the needle valve, and might become the cause of a flare-up. This cock should always be closed when leaving the car, so that one may know instinctively where to find it in case of a flare-up, and that it is in proper condition to shut off the gasolene.

In excessively cold weather trouble is sometimes experienced through the carbureter actually freezing. This is due to the supply of hot air not being sufficient, and the owner of the car should remedy this as soon as possible. A difficulty in starting sometimes occurs owing to the cold air preventing the vaporizing of the gasolene; a hot cloth should be applied to the carbureter.

Where the air intake to the carbureter is exposed this trouble will be increased so that in cold weather it is well to see that the end of the air intake pipe is arranged to draw as much air from around the hottest part of the exhaust pipe as possible. This is conveniently done by using a "tee" connection at the end of the intake pipe, so as to surround the exhaust pipe.

The proper running of the engine depends to a very great extent on the aperture of the jet being absolutely correct. If it is too small the engine will be starved, and if too great too much gasolene will pass to the mixing chamber.

With modern carbureters, it is not advisable to experiment too much with the jet as regards the aperture, as this has usually been carefully calculated by the manufacturers, and is

the result of extensive experiments by them. It may be well to point out, however, that it is possible for the jet to actually become enlarged in use, especially if it is very fine. In such cases the best remedy is a new jet supplied by the manufacturers.

In some carbureters, the air inlet is guarded by a finely woven brass gauze screen. If excessive dust is drawn in, this screen may become partially closed, in which case the mixture will be too rich, and popping and misfiring may result. The richness of the mixture may generally be detected by the smell. The remedy is to clean the wire gauze, which can be easily done by dabbing at it with a dry painter's brush, but it is advisable that the gauze should be detached from the carbureter before this is done.

In all modern carbureters there is a filter, situated generally at the point where the gasolene flows into the float chamber. This should be periodically taken apart, and thoroughly cleaned.

It is stated on the authority of one of the most notable oil experts that dust does actually pass through with the air into the engine and helps in the formation of deposit on the cylinder wall and piston head. It is, therefore, advisable that any extra air opening to the carbureter should be guarded against an inflow of dust from the radiator.

Where the carbureter is water-jacketed, it is necessary occasionally to undo the unions, swill the water jacket out, and examine the pipes to see that the water is circulating properly. Where the carbureter is jacketed by a by-pass from the exhaust, carbon deposit will accumulate in the jacket, and this can be cleaned out by hot water with washing soda dissolved in it. This cleansing should be done occasionally, otherwise, with a jacket of small dimensions, the deposit may choke all up and prevent the proper heating of the carbureter.

There is one important point in connection with carbureters having automatically operated air inlet valves, and that is to see that the sliding pistons are working quite freely in their cylinders. In some cases these are controlled by

means of diaphragm valves, generally of leather. The leather may become hard and cracked, in which case air will be drawn in and the automatic valve will not act properly. The remedy is a new leather diaphragm. In some cases the automatic valve is operated by a spring; the tension of this may vary, but generally provision is made for adjustment. In another type a dashpot using vaseline, glycerine, or other liquid, is applied to control the movement of the automatic air valve. In such a case it is necessary to see that, if the carbureter has from any cause become detached, the glycerine liquid is not spilt. If it should get spilt, the quantity will have to be made up, but otherwise no addition need be made, as the glycerine will not evaporate.

CHAINS,

Symptoms: Car stops.—Harsh noises.

Causes: Chains too loose, too tight, or clogged with mud.—Stone, or other foreign matter gets between chain and sprocket.—Broken or distorted spring causing chain sprockets to get out of line, and chain to mount the teeth.—Lack of proper lubrication.—Sprockets or chains worn.

Given a good chain to start with, there are only two causes likely to give trouble—improper adjustment and insufficient lubrication.

If a chain is left too loose, it is liable to jump the sprocket and come off, probably causing damage to itself or to the wheel before the car can be stopped. To adjust the chain, the top half should be held taut between the sprockets, and the chain stays tightened or loosened till the sag in the lower part is about one inch out of the straight. Chains which are too tight absorb power from the engine, stretch unduly, and are very liable to bend the chain stays.

In making the adjustment it is inadvisable to rely on the apparent tightness of the chain, otherwise, if one chain were worn more than the other, and both were adjusted to the same tightness, the back axle would be put out of alignment with the car. If it is known that the back axle is in true alignment with the car, then each radius rod may be adjusted

by giving the nuts the same number of turns exactly, which will keep the back axle square.

As the chain wears it is likely to stretch unevenly, and this must be taken into account when effecting an adjustment. Before tightening up the lock nuts or making the adjustment, the car should be moved slowly forward for one complete revolution of the chain, and if the chain becomes taut at one particular point, thus indicating uneven stretching, the adjusting nut must be slightly slackened. In wet weather it is well to examine the chains two or three times during the course of a day's run, for, although adjusted to perfection at starting, they may tighten up when smothered in mud, and must be readjusted to suit the altered conditions.

When a chain stretches to such an extent that a link has to be removed, both chains should be replaced by new ones. The same applies when one chain has stretched perceptibly more than the other, even although the extension does not amount to the length of a link.

Chain lubrication, though troublesome, as it necessitates removing the chain, is so beneficial to the life of the chain, and saves so much useless work being done by the engine, that it well repays the trouble it entails. The two main points are to remove grit and dirt, which grind away the metal in the links and rivets, and to insure a due amount of lubricant reaching each rivet and the interior or bearing surface of each block or roller. To remove all dirt, boiling in soda or potash water for half an hour is a good plan. The chains should then be hung up to thoroughly dry. When dry have ready a pan of best quality melted tallow mixed with black lead, into which the chains should be put to soak for a few hours; this insures the mixture reaching all the rivets, and when the chains are drained and wiped, they show a clean dry surface, to which mud and dust are not inclined to stick.

For a quick dressing kerosene may be substituted for the alkali boiling, but care must be taken to see that the kerosene between rivets and rollers is replaced by a lubricant.

Between these dressings, the chains should be treated daily

with an application of good chain dressing, as graphite, etc.

It is good practice occasionally, when chains require cleaning or greasing, to change them from one side of the car to the other, as it often happens that one chain will stretch more than another owing to greater driving strain coming on one side of the car than the other.

Spare links should always be carried in case of breakage. It is a tedious job, however, to cut out the broken link on the roadside, and entails much filing. It is possible to get home with one chain by lashing the sprocket on the other side of the countershaft fast to the frame, so that it cannot revolve. The drive will then be transmitted through the differential. The strain to the latter, however, is considerable, and consequently this expedient should not be adopted unless the motorist is near home. He should also keep on the low speed to reduce the strain as far as possible, and it would be a wise precaution to shed the passengers.

In modern practice chains are very often inclosed in oil-tight gear cases, in which case the use of graphite will not be necessary, as the gear case protects the chain from dust and dirt, but the oil in the gear case should occasionally be drawn off and replenished, and preferably the gear case should be washed out with kerosene. When the teeth of the sprocket wheels are worn so as to become hollow, and thus hold the slack of the chain up to the teeth, they should be filed up. Sometimes an improvement may be made by reversing them—that is, using the left-hand wheel on the right-hand side of the countershaft and vice versa. In this way the wear comes on the other side of the teeth, but if the wear is at all great, it is preferable to replace the sprockets at once. The same applies, but to a lesser extent, to the sprocket wheels on the road wheels.

THE CHANGE SPEED GEAR.

Symptoms: Change speed wheels fail to remain in mesh.—General noise at gear box and loss of power through increased friction.

Causes: Entering edges of change speed wheels have become

too rounded by excessive rubbing when speed changing.—Teeth too deeply in mesh.—Excessive play in bearings due to wear or want of adjustment.—Clutch forks or gear shafts distorted or twisted (the latter is of rare occurrence).—Actuating mechanism requiring adjustment or repair.—Gear wheels overhanging through lost motion in the connections.—Teeth broken or worn.—Gear wheels which are not in use grinding against each other.—Change speed lever or its shaft jamming or becoming strained.—Gear lever quadrant bent so as to jam or bind gear lever.

The teeth of the gear pinions should show a brightly burished surface on the faces, but not across the top or bottom of the faces. By "face" is meant the breadth of the tooth which engages with the opposite wheel. This denotes that the gear wheels are properly meshed as regards depth of engagement, but as in modern gear boxes this is an adjustment which cannot be altered after manufacture, no adjustment is possible nor likely to be required.

If the teeth are worn to a knife edge, the gear ring or the entire wheel will want renewing. The new wheels should be obtained from the makers of the car. The entering edges of the gear wheels will be rapidly backed or rounded off if harshly intermeshed when operating the change speed lever. This, though not actually dangerous to the gear teeth, or their driving power, may cause the gears to slip out of mesh, especially if there be much play in the joints of the striking gear mechanism—that is, the change speed lever and rods and the gear striking forks, by means of which the wheels are moved into mesh.

The speed changing movements should all be closely watched while manipulating the actuating lever. The wheels on the driving sleeve should move deliberately and accurately into their corresponding wheels—that is, provided the teeth are not directly opposite to one another. The edges of the wheels should be in a perfect line, not one overhanging the other; if they overhang it indicates considerable lost motion in the connections between the sleeves and the actuating lever. A certain amount of latitude is permissible here, but the movement should not be more than what might be termed "a little free."

If there is a lot of "backlash," trouble will follow. Test by holding the gear wheels in correct mesh and then operating the change-speed lever. Such backlash is generally due to the wearing oval of the holes in which the pins coupling the rod ends work, or the wearing of the pins themselves. Such wear will result in the gear wheels not being fully in mesh when the change-speed lever is itself right over the notch on the quadrant or sector plate. The remedy is to reamer out the holes in the rods forming the connection and fit new steel-pins, case-hardening both if possible.

It may sometimes happen that the quadrant through which the change-speed lever moves is damaged so as to become bent or distorted. It will then prevent the gear lever being freely operated. The remedy is to unbolt the two plates and straighten them out again so as to afford the lever free room, but not more than enough to allow it to move smoothly through the length of the quadrant.

The shafts carrying the various trains of wheels should be pulled upward, and shaken sideways to test for looseness in the bearing. If there is any sign of looseness they should be adjusted at once, or the wear will become excessive. See "Bearings."

In the Mercedes type of gear it is necessary to see that the locking arrangement which holds one pair of gear wheels out of engagement with the secondary shaft is working properly, and that the wheels are quite free from each other when the change-speed lever, through the medium of the selector bar mechanism, is operating the other pair of sliding gears. Otherwise the teeth of adjacent wheels may grind against each other and cause considerable damage.

Sometimes trouble may be due to the jamming or bending of the rocking shaft, which slides endways to engage with the selector bars. This may be caused by a strain set up in the tube through which it runs, or the shaft along which it slides, due sometimes to lack of proper lubrication, and in other cases to some maladjustment of the brackets which hold the bearings. The remedy in the first case is obvious;

in the other a lining up of the bearings on which or through which the shaft works is all that is necessary.

THE CLUTCH.

Symptoms: Engine runs fast, though car travels slowly, through clutch slipping.—Clutch bites fiercely or jerkily.—Will not engage or come out of engagement.

Causes: Slipping caused by oil or weak spring.—Fierce or jerky through leather hard, dry, worn, or through protruding rivets.—Jammed.—Wrong adjustment.—Insufficient play for clutch pedal.—Clutch remains slightly in contact when pedal operated, through leather being swollen.—In the case of disk clutches want of or improper lubrication or improper lubricant.

There are several different descriptions of clutches. A common type is the conical friction clutch, of which the fly-wheel forms the female portion, whereas the male portion is connected to the shaft which communicates with the gear shaft. This type of clutch is likely to suffer from either mud or oil getting on the leather bearing surface, and for this reason it should be cleaned by squirting gasolene between the faces. A force pump is useful for the purpose; the leather should then be treated with castor or clutch oil, preferably applied warm.

1. A Slipping Clutch.—This trouble can be located by the ear. The expert can tell almost at once if the engine is working at too fast a pace in relation to the speed of the car. If, however, he is uncertain, he should put his engine out of gear, dismount, and feel the male portion of the clutch with his hand. If the clutch has been slipping, the friction will have caused it to become hot. The slipping is usually due to oil on the bearing surface. Wash with gasolene, as already described, and then apply slaked lime or fuller's earth. Continuous slipping may burn the leather, necessitating its removal and replacement.

Sometimes the trouble is caused by the pressure of the spring on the male portion of the clutch not being sufficient. This can be remedied by fitting an additional washer, or substituting a new spring. In some cases there is a special ar-

rangement for adjusting the tension of the spring. A shoulder may also wear on the leather, which prevents the clutch going in far enough to engage, thus causing slipping. When this state of affairs is set up the leather should be replaced. A temporary remedy may be obtained by clearing away the upstanding edge of leather with a rasp.

2. *Leather Hard and Dry.*—When, through neglect, the leather of a leather-faced clutch becomes hard and dry, the clutch may possibly slip if let in quietly, but will grip fiercely if let in more suddenly. If the slip is caused through over-lubrication, it will be continuous, but when due to the surface being dry and polished it operates in a different manner. It can be easily understood that once the grip between any two surfaces is overcome, the tendency to slip is increased. In starting gradually, of course, the clutch is allowed to slip, and the trouble with the hard, dry clutch is that it continues to do so, but when let in suddenly it does not begin to slip, and, consequently, grips firmly, though this method of letting in the clutch is most detrimental. Generally, however, a hard, dry clutch leather does not slip, but grips fiercely.

To get the clutch leather soft and pliable once more, sluice the clutch well with kerosene, letting the clutch in and out, and turning it round during the operation, so that every portion of the leather is treated. The clutch may next be treated with gasolene so as to clear the kerosene out of it, and then, when dry, should have castor oil, or any of the special dressings sold for the purpose, well brushed into it.

In most modern cars having leather in the clutch, the male member of the clutch can be readily dismantled, and when this is the case the treatment of the leather becomes much easier and more convenient.

To maintain the clutch in good condition afterwards, apply a very small quantity of castor or neatsfoot oil at regular intervals, and should the clutch slip through overapplication, wash out with gasolene. After such treatment it is advisable to keep the clutch out of engagement for a few hours by placing a heavy weight on the operating pedal.

3. Too Fierce a Clutch.—This is a very unpleasant failing, as it is impossible to let the clutch home gently, and so take up the drive of the car without a severe jerk and strain. The application of dry graphite is the best remedy, so that the clutch will slip a little when first applied. Oil mixed with a little kerosene may also prove effective, but it may result in making the clutch slip too much. The trouble is generally due to the clutch leather becoming dry and harsh from want of attention. Regular dressing with a small quantity of castor or neatsfoot oil is the best preventive. The clutch may slip a little at first after application, but this will soon stop. Protruding rivets also tend to make the clutch grip fiercely.

4. Worn Leathers.—In process of time the leather is liable to wear. If the wear is uneven the clutch will grip in jerks. In case of excessive wear the clutch may fail altogether to act. In both cases it will have to be relined. If possible, the old leather should be removed intact, as a guide when cutting the new one. This should be taken from the thick part of the hide and fitted rough side out. Great care must be taken to countersink the holes for the rivet heads about 1-16th of an inch, so that they rest below the surface of the leather.

5. Clutch Rivets Protruding.—The leather is usually fixed to the metal center of the clutch by copper rivets, whose heads are countersunk. If these rivets are not originally countersunk sufficiently, or if through wear of the leather they become level with the surface, the clutch may grip fiercely when applied, and may even seize or jam. To allow for wear and compression the rivets should be originally 1-16th of an inch below the outer surface of the leather.

6. Jammed Clutch.—Clutches are generally made to slide along a shaft so that they can be put in or out of gear, and when worn, insufficiently lubricated, or not mounted in line grip fiercely when applied, and may even seize or jam. A clutch may jam when out of gear and refuse to spring into place when the lever is released through want of lubrication between the clutch and the shaft, or the spring by which it is

forced into place may have lost its power by becoming soft or broken, or there may be some unevenness of the sliding bearing which prevents the clutch going home. Very often the clutch may be made to engage in an emergency by putting the toe under the pedal.

A clutch may also appear to take its proper place and yet continually slip; this, again, may be due to the bearing, or to its being out of line with the fly-wheel, and can be investigated by slipping a knife blade round the leather face when in position. If the blade is loose on one side and tight on the other, it will show that the shaft is not in line. This trouble is often accompanied with noise and harshness, especially when starting. In such cases it may be due to the under-frame of the car having warped or got out of alignment with the main frame, so that the clutch shaft and the engine shaft are not in the same plane.

The leather covering, unless very evenly put on, may prevent the clutch taking its proper position, and must be pared in the tight places. A clutch may also become jammed when in position and refuse to come out of engagement. This is generally due to the guide piece which projects from the shaft and runs in a spigot bearing becoming scored, and eventually getting jammed in its bearing. Want of lubrication is the cause, or jamming may result from the rivet heads protruding through the clutch leather. Trouble may also, though very seldom, be caused through broken balls in the bearing in the fly-wheel. If the bearing locks in consequence the clutch may jam.

Sometimes the clutch leather swells from the effect of wet, and takes up the drive jerkily. Wedge the clutch open and apply fuller's earth to absorb the moisture, then brush off the fuller's earth and apply clutch oil or other dressing.

In the De Dion type of expanding clutch, jamming may be due to want of oil in the gear case, or to faulty adjustment. In this type the slipping of the clutch is generally due to faulty adjustment.

7. Wrong Adjustment.—Wrong adjustment of the actu-

ating mechanism is a frequent source of trouble. The rods and levers must be so adjusted as to let the male portion of the clutch right home when the foot is removed from the pedal. The adjustment is further complicated by the fact that the brake levers are often connected up in such a manner that when the brake is applied the clutch is withdrawn.

Disk or plate clutches have during the last few years come into extensive use. They seldom get out of order except through lack of or improper lubrication. If the lubrication is neglected, the plates or disks may seize, which is a serious trouble, and may necessitate the renewal of some or all of them. The lubricant should be of such a consistency as not to gum up. If the oil is too thick the plates or disks may not disengage quickly or easily, while if too thin, it may not lubricate them sufficiently. The makers' instruction as to the oil to be used and the quantity should be followed.

In some types of disk clutches the edges are split to form flat springs, which prevent the too sudden engagement of the clutch, and also allow of its quick disengagement. Adjustment is always provided to the spring which keeps the plates or disks in engagement.

Sometimes by racing the engine for about a minute, then throttling off and getting quickly into the low speed, the plates of a clutch which have temporarily seized may come apart.

COMPRESSION—BAD.

Symptoms: Engine loses power, and very little resistance shown when starting handle is turned.—Hissing sound.—Slow to start.—Misfires.—Overheating (note if pressure is escaping into base chamber).

Causes: Escape of compressed mixture from combustion chamber from following causes.—Valves pitted.—Valves stuck in guides.—Valve spindle bent.—Valves freshly ground.—Faulty joint between the seat of inlet valve and combustion chamber.—Cracks in combustion chamber walls or valve seatings.—Too thin lubricating oil.—Slots of piston rings coinciding with each other, or rings sticking in grooves.—Worn rings.—Broken rings.—Valve spindles too long, or springs too weak.—Spark plug cracked or broken; gland nut loose;

escape between core and metal; washer faulty.—Escape of pressure at rocking lever or igniter plug in low tension magneto ignition.—Compression cock open or leaking.

If there is no compression whatever, it will generally be found that a valve is either stuck up or broken. If the starting handle can be more easily operated than usual, or if a hissing noise as of escaping air is heard, it may be taken for granted that the compression is weak. In a multi-cylinder engine the compression cocks in all but one cylinder should be opened and each cylinder tested separately. If there are no cocks, the exhaust valve stems should be lifted and held up with the aid of a screwdriver or suitable (hand inserted) wedge.

The best way to definitely locate the trouble is to brush soapy water or squirt a moderately thick oil round the joints, etc., and then watch for bubbles rising, while the crankshaft is being revolved by hand, with the ignition, of course, switched off. This leakage may proceed from any part of the cylinder head where there is a joint—as, for example, at the spark plug, at the exhaust valve, between the cylinder walls and piston rings, at the inlet valve, under the inlet and exhaust caps or flange joints, and, in the case of engines having detachable combustion heads or plates, on top of same, at their jointings.

An advantage in testing by hand-operating the crankshaft is that it enables the noise due to leakage of compression to be more clearly noted, besides making it easier to handle the parts affected. Soap or oil bubbles due to the above cause are then more readily and rightly diagnosed, whereas, when the combustion chamber becomes heated, such bubbles might really be produced by the heat acting expansively on them. Leakage at the valve caps may be suppressed by putting a moderate pressure on the flange nuts or screwed caps, as the case may be. If such fails, take off the cap or flange, and carefully remove the existing packing. It is not good practice to place a fresh copper-asbestos packing washer over another. All faced joints should be slightly concave, and when being

faced in the lathe should have one or more thin rings (according to the diameter of the face), about 1-16th inch deep and the same width scribed on the surface. It is a mistake to use packing of too great thickness. Flanged joint packing should not be more than 1-16th inch thick, and made of only best quality asbestos millboard, the jointing, previous to using, being soaked in boiled oil and afterwards dusted on both sides with powdered graphite, so that the joint may be easily taken apart without breaking the packing. The use of red or white lead is not to be recommended.

All nuts holding joints should be again tightened after the engine has warmed up, failing which they will often be found slack when it becomes cold, and, if not noted, the subsequent starting of the engine may result in the jointing being blown out, or leakage may become apparent. Always note that the threads of all studs or valve caps reach well above or below, as the case may be, the flange or hole. There should be at least three full threads below the top of a flange when the same is bolted down. Failure to note this point may lead to the breaking of a stud, or in the case of a screwed cap, inability to tighten it in place, the result being a partial loss of compression.

A broken or bent valve, broken spring, or too weak spring, or a valve spindle which is too long, and thus prevents the valve from closing, will also cause a leakage. In the latter case it is well to remember that metal expands with heat, and consequently, though there may be no loss of compression at starting, when the spindle heats it will become slightly longer, and if there is no clearance when hot this may result in the valve not seating properly. The valve may get stuck up through a bent spindle or a clogged guide, or owing to a weak spring may close so sluggishly as to permit an escape of pressure.

The next point is to examine the valves themselves. They should be carefully cleaned and examined to see if they are pitted, as if this is the case there will be a loss of compression, and they must be carefully re-ground. Much time in

grinding may be saved by at once noting if the seating line on the valve face shows up almost perfect over its circumference. If not, this may be taken as an indication that the spindle is bent, or that the head is distorted. A further trial by "chucking" the spindle in a self-centering lathe-chuck will prove the point. If appreciably out of true it is advisable to substitute a new valve, leaving the other to be dealt with at leisure. After grinding a valve or fitting a new one, the compression will not be absolutely perfect until the car has run some distance. Grit under a valve will, of course, prevent it seating and allow of an escape. Cleaning will remove that trouble. See Valves.

Leakage at or through the spark plug is another cause of trouble. As regards the former, it is usually remedied by screwing home the plug or substituting a new washer, in which case it will be well to again tighten the plug after the engine has been running a little time. If there is still a leakage here try a second copper-asbestos washer. It is advisable to note that some forms of porcelain plugs require the gland nut to be tightened after a brief usage, failing which the central or positive pole will loosen and turn, causing misfiring or actual failure of the spark. There may also be an escape between the insulating core and the metal of the plug, in consequence of the plug being cracked or broken. The remedy is to replace the plug if, after screwing down the gland nut, no better result is obtained. Leakage here will show in the form of a brown deposit on the white surface of the porcelain.

In the case of low-tension magneto ignition, an escape sometimes occurs where the spindle of the rocking lever penetrates the side of the combustion chamber. It will need cleaning and grinding. (See Ignition, in the articles that follow.)

Bad compression also results from leakage past the piston rings, and can be best diagnosed by feeling the base chamber. Excessive heat there is a sure index. Sometimes the rings become stuck in the grooves owing to burnt oil, and

fail to make a gas tight joint. Remedy: pour in gasolene or kerosene on top of piston, and work the starting handle. If this is not successful the rings may have to be removed and treated as described under Piston Troubles in the following pages.

Some engines appear to have perfect compression when cold, but not when hot, due to badly formed castings which are not properly water-jacketed, so that when hot the valve seat is distorted and the valves do not completely shut. In modern engines this fault rarely occurs.

CONNECTING ROD OR CRANKSHAFT BROKEN.

Symptoms: Knock in crank case.—Sudden stoppage, accompanied by loud, clanging noise in cylinder and crank case.

Causes: Premature ignition.—Wrong timing of ignition.—Clutch let in suddenly.—Seized piston through lack of lubrication.—Brakes applied forcibly with clutch in engagement.

These breakages are of rare occurrence, and the repair is too difficult to undertake except in a well-equipped shop.

Prevention is better than cure, however, and therefore we shall enumerate the most likely causes:—Any unusual strain, such as that caused by too early firing; two or more cylinders firing against each other; too severe a strain caused by delaying too long in changing gears on a gradient, which has the effect of making the engine labor; severe shock, such as suddenly altering the speed of the engine; interference with the free motion of the pistons through insufficient lubrication, causing them to seize. The sudden letting in of a fierce clutch with the engine racing, as has been the practice in starting on hill-climbing competitions, puts an enormous strain on crankshaft and rods, and should therefore be avoided. The strain on every part of the mechanism is great, and will take more out of the life of a car than many miles of careful driving.

The sudden application of the brakes without taking out the clutch when the car is traveling fast is also liable to put too great a strain on the engine shaft and connecting rods.

CYLINDER TROUBLES.

Symptoms: Loss of compression.—Engine power weakens.—Misfires.—Escape of water.

Causes: Cracks in cylinder jacket.—Cracks in water jacket.—Blow holes in cylinder casting.—Scoring of cylinder by end of a loose piston pin.

Other troubles which arise inside the cylinder, but which cannot be classified as cylinder troubles, are the following:—Knock, due to seizing of the piston in the cylinder (see Knock); loss of compression (see Compression—Bad; Piston); crack due to freezing of water in circulation system (see Circulation); leaking valves (see Valves). These references deal principally with headings in this volume, but the reader may with profit secure additional information on these subjects from that exhaustive work, the *American Cyclopaedia of the Automobile*, which treats of them in great detail.

Little trouble is to be anticipated so far as the cylinder itself is concerned, provided the piston is kept well lubricated. At first, and until the piston rings have, as it were, properly bedded themselves to the cylinder walls, the compression will not be particularly good. The same effect will be noticeable when the rings have lost their elasticity or become cracked, or in the event of the slots in any pair working into a common line.

As regards trouble from the cylinder casting itself, the chief danger is that due to a burst water jacket. This may arise from the water freezing in the cylinder jacket and expanding in frosty weather, if the radiator and jacket have not previously been emptied (see *Water Circulation*, in the articles that follow); or, in the event of the cylinder having overheated by reason of a failure of the pump or some other obstruction to the flow of the circulating water. If overheating occurs through this derangement of the pump or other obstruction, it is dangerous to immediately pour cold water into the radiator, and even more dangerous in the case of a leak of

water in the circulation system.

A further ill-effect where excessive overheating has taken place may be looked for in a partial distortion of both the cylinder and the valves. It is essential, therefore, that the driver when on a journey should frequently satisfy himself that the circulation is working correctly. In that respect a manometer or little pressure gauge, fixed to the dashboard, will be found useful, but is not absolutely to be depended on.

In the event of a leakage, care must be taken to discover the cause; a suspected crack may often lead one astray, and the leakage be traceable to a trickling or leaky union, or (in the case of engines having detachable top or side metal plates or doors to the cylinder jacket) to a leaking joint. Fractures in the surface of the jacket are usually intimated by a sweating of moisture, which will quickly reappear on wiping or drying the parts. This species of crack will sometimes only reveal its presence when the engine is running. Another type of crack is at once noticeable by the line of fracture being readily visible. Minute leakage, due to blowholes in the casting, is sometimes mistaken for fracture.

We will deal with each in turn. (It must be understood that we deal only with fractures in the exterior walls of the cylinder jacket. Fracture in the walls of the cylinder itself cannot be satisfactorily repaired, and where such occur, a new cylinder casting complete should be procured.) Minor cracks of the first order may be treated—if there be plenty of working space in the region of the crack—by first filing to a bright surface the two sides of the spot, and then tinning the surface with solder, using tinsmith's ordinary killed spirits of salts as a flux. Where the casting suggests porosity, or a tendency to sweat, it is generally sufficient to fill up the jacket (having first plugged the pipe unions) with a strong solution of sal ammoniac, and leave it for a couple of days. A further period for hardening after running off the sal ammoniac solution must be followed by a rinsing with fresh water.

Where the crack is a gaping one, which is, in modern practice, very improbable, the best remedy is a patch of soft plate iron screwed upon the jacket by means of small screws and packed by a thin layer of asbestos millboard. This is essentially a workshop job, to be done by skilled mechanics.

A blow-hole of any size should at once be drilled and tapped to take a metal plug of sufficient diameter to clear all traces of the spongy part.

Where cylinders have been cracked through both outside and inside walls the repair is extremely difficult, but we have heard of good repairs being made in such cases by a patented process of burning together new parts. They require afterwards to be remachined.

If the cylinder walls get appreciably scored through the piston seizing, or from any other cause, it may be necessary to have them re-lapped, or in a bad case even re-bored. A new piston in the latter case will be necessary.

It sometimes happens that a piston pin comes adrift in a piston and, moving sideways, scores the cylinder walls. Before it can become so loose as to do this, however, considerable knock will be set up in the engine. If this knock (see Knock, in this series of articles) is attended to at once, the saving of the replacement of the piston in the cylinder may be effected. If the end of the piston pin has scored the inside walls of the cylinder to any extent, the power of the engine will be very greatly reduced, and the only remedy will be the re-boring of the cylinder and the fitting of a new piston and rings. In extreme cases it may be necessary to fit new cylinders.

THE DIFFERENTIAL.

Symptoms: Grating noise.

Causes: Teeth of pinions or driving bevels stripped.—Shaft bearings want adjusting.—Road wheels require adjusting.

In modern motor vehicles there is little probability of any derangement to the teeth of the differential pinions or crown

and bevel wheels. Such can only occur through bad adjustment of the sleeve which carries the short shaft on which the bevel pinion revolves. Little adjustment is required here, and if any becomes necessary through wear it will be best effected by the makers of the car or their accredited agents.

If such serious trouble arises as to cause stripping of the teeth of any of the wheels or pinions in the differential, then the car should not be run further, and the repair or replacement should be left in the hands of the makers.

Proper adjustment of the wheel bearings and careful attention to the lubrication of the differential gear should prevent the possibility of derangement in this part of the mechanism of any really well made car.

THE GOVERNOR.

Symptoms: Engine suddenly accelerates.—Hunts.—Difficulty in keeping engine running at constant speeds.—Engine runs dead and picks up badly.—Loss of power.

Causes: Springs too strong, too weak, or broken.—Sticking of governor arms, toggles, or the sliding sleeve and grooved collar which communicate motion to the throttle operating mechanism.—Backlash and bad adjustment of operating rods and mechanism.—Actuating rods wrongly adjusted.—Accelerator wrongly adjusted.

This part of the mechanism is formed on a well-known principle. Its most serious defect is a tendency for the springs to weaken from use, with the result that the governor comes into action too soon, and the engine fails to give its full power. It is essential that the springs should be exactly of the right tension. Want of lubrication may cause the arms carrying the governor weights to stick. Hunting, too, is another trouble to which the governor is liable, as when the load is suddenly taken off. If the accelerator or actuating rods are wrongly adjusted the governor may not come into action properly, or may come into action too late and cause a sudden opening or closing of the throttle. This can only be remedied by rebushing the holes in the actuating rods or reaming them out and fitting new and larger hardened pins.

THE IGNITION.

Symptoms: Car moves sluggishly and jerkily.—Car stops.—Mis-firing.—Smells.—Explosions.—Knock.—Harsh running.

Causes: Short circuits in spark plugs, igniter, coil, wiring, contact maker, contact breaker, distributor, condenser, battery.—Battery run down.—Spasmodic working of circuit.—Preignition due to overheating.—Timing wrong.—Loss of compression at rocking lever of igniter.—Disconnection of condenser.

The ignition, unless properly understood, may become the most fruitful source of trouble, particularly in the case of the beginner. It is therefore well worth while to study it carefully.

Short Circuits.

The electric current will always travel by the path which affords the least resistance. The resistance to the spark jumping between the points of the plug is very considerable, and consequently there is a great tendency for the current to take a path of less resistance. The immediate result is that the spark in the combustion chamber fails altogether through want of pressure, or becomes so attenuated as to be insufficient to ignite the charge properly. Short circuits either in the high or low tension circuits have the same result, but are more liable to be found in the high tension circuit.

To cause a spark to pass at the points of a spark plug, even in the open air, requires considerable electrical pressure or voltage, and this voltage must be very much increased to produce the spark under the working conditions met with inside the cylinder of an internal combustion engine. Not only the high compression in the cylinder, but also the gas mixture, tends to very considerably increase the resistance to the passage of the current, and hence reduces the sparking effect. Therefore it is necessary to remember that a good spark in air does not necessarily imply that the same good spark will pass when the engine is at work.

A weak spark may fire a charge under slight compression, but fail under full compression; hence it may fire the charge at low speed, but fail at fast speed.

Any source of current capable of discharging across the plug at the rate of one to three amperes at 4.2 volts pressure is suitable for sparking purposes. Few engines will run well with less voltage or electrical pressure.

If the dry battery or storage battery (accumulator) is giving a current of the above strength and the sparking is still defective, it is safe to look for the fault elsewhere. It must be remembered that either dry cells or storage batteries, but especially the former, are capable of giving such a current after a brief rest, even although they may be practically exhausted so that testing should be done while the engine is running or immediately after, otherwise the true working pressure will not be shown by the testing instrument.

As defective sparking is due in most cases to battery trouble, it saves considerable time to try the effect of a new one before searching for faults elsewhere.

In the case of persistent misfires, it is a good plan to get the loan of another coil and see if the engine will then run satisfactorily. If it does, the motorist will know that the short circuit is in the coil.

In magneto machines the permanent magnets after a lengthy period may lose their strength, and require to be remagnetized. They should be sent to the makers for this purpose.

In high tension ignition using a coil and a dry or storage battery, short circuits are likely to occur in the following units:

- | | |
|-------------------------------|---------------------|
| 1. The Wires and Connections. | 5. The Distributer. |
| 2. The Switch. | 6. The Spark Plug. |
| 3. The Contact Maker. | 7. The Coil. |
| 4. The Contact Breaker. | 8. The Battery. |

(See Short Circuits in Table II, at beginning of the present work.)

(I.) **The Wires**—With the constant jar and vibration of a motor the connections of the wires are apt to loosen, setting up great resistance for the current to overcome in its circuit; also, due to the vibration, they may only close the circuit intermittently, and no current may pass at the moment it is required to produce a spark. Where any of

the connections are placed in positions in which they are subjected to wet, oil, mud, grease, etc., these substances are very likely to find their way between the bearing surfaces of the connections. Moisture when present is a good conductor, but when it evaporates it leaves a rusty or dirty deposit behind, which will offer a considerable resistance to the current, if it does not entirely prevent it passing. Oil is particularly likely, on account of its creeping properties, to find its way between the connections and prevent the current passing. If the joint is tight, however, it can do no harm.

Examine all the connections to make sure that they are not loose. If they are dirty, wash with gasolene and scrape the faces which form contact, and then rub with fine emery paper. See that the connections to the battery are secure, and that the acid, if a storage battery is being used, has not corroded the contacts. A thorough cleaning with ammonia followed by an application of vaseline, will prove an excellent protector.

If this cursory examination should not disclose any fault disconnect the wire from the sparking plug, and with the switch in position hold the wire by the insulated portion (preferably with gloves on) within about one-eighth of an inch from the metal of the engine, and get someone to turn the starting handle, or vibrate the trembler in case of a make-and-break contact maker. Great care should, however, be exercised in carrying out this test, for should the wire be held at too great a distance from the engine for the current to pass, the jump may take place inside the coil, by perforating the insulation therein. If this is repeated a sufficient number of times, it eventually ruins the insulation, and may happen with even the highest class coil.

If a good spark passes, it may be taken for granted that the connections are not loose, nor the wires faulty, and the sparking plug should next be examined, as explained later.

If, however, no spark, or a weak spark, passes, the wires should be examined for short circuits or breaks. Each length of wire should be carefully examined to make sure that the

insulation has not become worn through chafing against any portion of the frame, or burnt through contact with the engine or exhaust pipe, thus allowing the current to escape. If this is found to be the case, the defective place should be bound with insulated tape, or the wire run through a rubber tube, or a new wire fitted.

All wires should be carefully protected from friction against pipes, tanks, etc., and where the wires are supported, they should be wrapped round with some extra protective material. A piece of good rubber pipe large enough to slip over the wire forms an excellent and easily-fixed protection. Metal staples are a convenient mode of fastening wires to timber, but great care must be taken when using them to see that they do not pierce the insulation, and it is always safer to slip in a piece of sheet rubber between the staple and wire before driving it home. Slips of leather are also useful means for securing wires.

A short circuit may also occur, as already mentioned, through defective insulation in the wiring of the coil, but this can be traced through the defective working of the coil itself.

Water acts as a conductor, and if the insulation is saturated with water or mud this may be the cause of trouble. The only remedy is to protect the wire properly.

A short circuit is most likely to occur in the high tension wire, which runs from the coil to the spark plug, as the current running through this is of high voltage. Special pains should be taken to see that this wire is well insulated, even to the extent of running it through a special rubber tube.

To determine definitely whether the low tension wiring is at fault either in the direction of "short" or of breakage the following system is an infallible means, provided the very highest class voltmeter is used. A cheap article does not give sufficiently accurate reading.

To test for short circuits connect the voltmeter to the battery terminals after having put the switch and the contact maker in such positions that the current cannot flow. Take

the reading of the voltmeter. Now complete the metallic circuit by means of the switch and note the reading of the voltmeter again. If the reading at the battery is lower, it shows that there is a short circuit somewhere in the wiring, and that some of the electricity is leaking back to earth and hence back to the battery through a short circuit.

To test for a fractured wire, causing a broken circuit, put the switch in the "off" position and place the contact maker blade or wiper in such a position that the current would flow if the switch were "on." This is equivalent to an open circuit, the switch being off. Note the reading of the voltmeter. Now put the switch in the "on" position; the voltmeter should give a lower reading due to the circuit being completed through the switch. If the voltmeter needle remains at the same point it shows that the circuit still remains "open" through the medium of a break in the wiring. The same test can be carried out in the case of the make-and-break system of contact maker by bringing the platinum points into contact in testing for a "short," and out of contact when testing for a break.

To locate which wire is in fault, disconnect one end of the wire to be tested, the other end of which should of course be in contact with one of the terminals of the battery. To this wire attach one wire from the voltmeter. Then make momentary contact between the other wire of the voltmeter and the opposite pole of the battery. If the wire is completely broken no current will pass. If, however, there is a short circuit, the indicator will show a lower voltage than it will show when its wires are attached to the terminals of the battery. If a voltmeter is not available, a tiny four-volt lamp, such as is used for testing storage batteries, should be inserted in the circuit. If the light is weak it will indicate a leakage or a break. A broken wire must be replaced; a leak may be remedied by the use of insulating tape.

The old wire may be made to do temporary duty by cutting it across at the broken place, peeling back the insulation for half an inch on either side of the break, twisting the

wires into each other, and, if possible, soldering them, the join being then thickly wound round with insulating tape. Should there be a breakage, but the ends remain at the same time touching, it is often most difficult to locate, because the engine will run intermittently.

Persistent trouble with wires can be avoided by covering all connections with sheet rubber bound on with insulating tape. In case of chronic failure of the insulation, re-wire with the best insulated wire.

To make reliable connections, twist the numerous small wires into one solid wire, give this a turn around a piece of metal slightly larger in diameter than the screw which is to pass through it. Form the loop, so that from a quarter to half an inch of the extreme end of the wire will lie parallel to the main piece of the wire; bend around it a turn or two of fine wire to keep it in place. Solder the whole together, including the loop, being careful to see that the solder runs well into the center of the wire. Use resin as a flux. Spirits of salt should not be used on any account. Lay the loop on a flat surface and slightly flatten it with a few blows of a smooth-faced hammer, to give a good contact surface; then replace the wire and bind with insulating tape. It pays to take the greatest care with all connections.

A "short" on the high tension wires can often be detected by running the engine in the dark, when a spark will be seen at the seat of the trouble. A short of this nature is apt to ignite a gasoline leakage. Sometimes it is due to the insulation being of bad quality. To test this point, moisten the wire and run the hand over it while the engine is running. If any shock is experienced renew the wiring. This should be done when the other hand is in contact with some metallic part of the engine or mechanism.

In multi-cylinder engines the high tension wires should be numbered to obviate any risk of attaching them to the wrong spark plugs.

Short circuits in the case of magneto ignition are dealt with under "Magneto Ignition" toward the end of this article.

(2.) **The Switch**—Shorts may occur at the switch; it may fail to act altogether or to break the circuit when in the off position. The metallic contacts should be perfect, and the wiring firmly connected to the switch terminals. To test for absolute failure, disconnect the wires and join with a temporary connection. If the engine then runs perfectly the switch is at fault.

To test for failure to cut off the current when in the off position, operate the starting handle; if sparking takes place it will indicate that the switch is not breaking the continuity of the circuit. The trouble may be due to straggling wires getting across the contacts.

(3.) **The Contact Maker**—The contact maker is very often a source of trouble and weak sparking. There are two types—one that makes contact through pressure on platinum points, and one that makes a rubbing or “wipe” contact. They require different treatment. The correct use of the terms contact maker, contact breaker and commutator can only be learned by study of the various systems of ignition.

As regards the positive make-and-break system of contact maker, where there is no friction to keep the platinum points clean, they require frequent cleaning to get rid of the oxidized metal and carbonized oil caused by the spark. Very little oil on the points is sufficient to prevent the passage of the current, so that the points must be occasionally wiped or washed with spirit to remove the burnt oil. The quality of the spark depends largely on the adjustment of the blade—that is, the pressure between the two platinum contacts—and the sharpness of the break.

No hard-and-fast rule can be laid down for this adjustment, as much depends upon the engine, coil, current, and the contacts of the maker. Each must be adjusted to the engine to which it is fitted, by running the engine and then adjusting the platinum-pointed screw till the best results are obtained. It is generally a sign that there is wrong adjustment if the car moves jerkily when the ignition lever is in one position, and steadily when in another. To put it right, turn

the starting handle until the cam brings the platinum points into contact. The binding screw having been slackened, the platinum-tipped screw should then be adjusted until the platinum point rests lightly against the platinum point on the trembler. It should only rest lightly on it, however, and not cause an appreciable bend.

It is a good plan to make this adjustment by means of a turn-screw while the engine is running. The mere fraction of a turn will make all the difference between correct and incorrect adjustment, more especially as regards the timing. (See Timing.) Also an adjustment which will give satisfactory running at low speed may not work well at high speed. Therefore the screw should be turned little by little while the ignition is advanced and retarded alternately. When the best position is attained by experiment the locking screw or nut should at once be screwed home, thus securing the platinum-tipped screw in position. The operator should make sure that the adjustment is the same in the case of all the cylinders or the relative timing may be upset.

Care should be taken to see that the platinum contact on the spring blade is exactly opposite to that on the platinum-tipped screw, so that a good concentric contact is made between them. An effective method of checking this is by greasing the two platinum points and pressing a white card between them so that they mark it on each side. Run a pin through one mark, and if it is in the center of the other the surfaces are concentric. Clean the grease off after checking position. Dirt on platinum points will cause misfires. By springing the trembler outward and inserting a card between the points and then pulling it out again, the surfaces can be cleaned. Sometimes the platinum surface becomes pitted by use. Both the trembler and the set screw should be taken off, and the surfaces filed quite flat with a very fine file, rubbed with emery cloth, and readjusted. If they are not filed flat, the surfaces will not come together truly, and bad sparking and faulty timing will result. The best method is to place the blade in a small hand vise parallel to the jaws in such

a position that the platinum point only just projects above the vise. It can then be filed absolutely level without difficulty.

At all times when an adjustment of the blade or the platinum-tipped screw has been made, be careful to test the running of the engine with every position of the rocker of the contact maker, taking care, of course, not to unduly prolong the test, as it does not improve the engine to allow it to race unrestrictedly.

Oil may collect both under the spring blade where it is secured to the metal, and between the platinum-pointed screw and the block which supports it, preventing a free passage of the current. The entire ignition apparatus should occasionally be taken asunder and well washed in gasolene.

Sometimes the platinum on the trembler becomes loose, and the spark occurs intermittently; a gentle tap with a hammer, so as to rivet it up, will often put it right. If the solder at the back of the blade has dropped off, it is a simple matter to resolder it. Needless to say, correct timing of the spark is all-important. This subject is dealt with in the chapter on Overhauling.

The Wipe System Contact Maker.—In this system, which is in very wide and constantly increasing use, it is most important to keep the insulated disk well lubricated with a thin oil such as is used for bicycle bearings, as the constant friction forms a cake on the brass insertion of any dust that collects there, and prevents the block at the end of the blades or the brushes taking up the current. These contact makers give little trouble if lubricated as above described and kept clean from dirt and thick foul oil. The pressure of the contact pieces on the disk is sufficient to prevent any road vibration from “jumping” them. All the terminals must be kept tight and clean.

The contact blades or brushes are kept to their work by springs. If these are too weak contact will not be firm enough, and if too strong the wear will be excessive. It is not an uncommon thing to find the metal contact pieces which are let into the insulating disk badly grooved or worn, with

the result that the brushes jump and cause intermittent sparking, especially at high engine speed. The disk should be put into a lathe, and a very slight layer skimmed off it, so as to make it smooth and true.

It occasionally happens that the fiber disk of the contact maker of a multi-cylinder motor becomes impregnated with minute particles of metal scrapings, caused by the friction of the contact blades with the brass insertion pieces set in the disk. This will set up irregular firing, and it may become necessary to have the disk skimmed up anew in the lathe. The use of a magnifying glass will readily reveal the presence of metal particles.

Another source of trouble where a fiber disk is used, and one that might well puzzle the novice, occurs frequently in damp weather, and is due to the property possessed by red fiber of absorbing moisture from the air, which swells it until the metal contacts are no longer flush. Thus when the engine is running at its normal speed the wiper blades either make a very poor contact or jump the contacts altogether, although when, in testing, it is turned slowly with the starting handle, the coil buzzes all right, and there is a good stream of sparks at the plug. The only real cure is to have the contact trued up by having a light cut taken off in the lathe, as already described, but when on the road something may be done by carefully scraping or filing the fiber for some distance in front of each contact piece.

It is essential that the brushes should make contact with each metal segment when the pistons in the various cylinders are relatively in the same positions. This subject is fully dealt with in the chapter on Overhauling.

The return of the current from the contact maker through ground to the battery is sometimes interfered with through a loose bearing or through an accumulation of dirt or oil. It is now generally provided for by a spring plate behind the contact maker or a wiper which keeps it in metallic contact with the body of the engine.

In the roller type of wipe contact maker, another popular

Contact Maker, the disk system is reversed. The fiber ring, with the metal sectors (on which the roller makes contact) let into it, is stationary, while the roller revolves with the camshaft, and is kept up to its work by a spring. If the spring becomes weak, or the roller pin wears, or the arm gets askew, misfiring is likely to result, generally accompanied by sparking inside the contact maker. As in the case of the other type of wipe contact maker, the metal and fiber surface of the ring must be true. The whole appliance should be kept well oiled, be frequently cleaned, and worn particles from the sectors removed. In the case of the positive contact type, in which cams (or a single cam) operate flexible blades and put platinum points in contact with each other in order to allow the current to flow during the time that the coil is trembling, the appliance is often so arranged that the contact surfaces slide across each other, and thus tend to automatically clean themselves and give a good flat contact between each pair.

(4.) **The Contact Breaker**—We have adopted this term to describe the method employed in the case of magneto ignition to effect a break in the low tension circuit. In the case of high tension magnetos, the contrivance is much the same as the ordinary positive make-and-break contact maker, except that the platinum points are normally touching and only momentarily separated by the cam. The contacts must be kept clean and true, as in the ordinary type, and should make firm contact with each other.

In the case of low tension magneto ignition the contact breaker is the appliance which causes the contact arm to separate from the igniter inside the combustion chamber. Immediately the circuit has been opened it is closed again by the action of a spring or other means.

(5.) **The Distributer**—The function of the distributer when used in connection with the coil and battery system is to synchronize the firing of the different cylinders and to obviate the necessity of having a separate coil for each cylinder of a multi-cylinder engine. (See Timing.) In some high

tension magneto machines it is mounted as part of the magneto machine, and, while synchronizing with the action of the contact breaker, distributes the high tension circuit to the various cylinders. The possible troubles which may occur are the same in both cases, and are described further on in this article under "Magneto Ignition."

(6.) **The Spark Plug**—To examine the spark plug, first disconnect the wire, unscrew the plug from the combustion chamber, reconnect the wire, and place the plug on the metal portion of the frame, or on the top of the combustion chamber, taking care that only the metal portion of the body of the plug is in contact. The cap or screw should not be in contact. Then turn the starting handle, as described in testing the wires. If no spark or a weak spark passes, it may be taken for granted that the plug is at fault, and it should be examined in detail.

If the points of a spark plug are placed about one millimeter (or 1-25th of an inch) apart, and there is a good voltage from the battery on making contact, so as to set up an induced current, a "fat" spark usually results. It has the appearance of a halo or zone of radiance bushing out on each side of a line drawn between the points of the spark plug. Now, separate the platinum points another millimeter, and the spark will be seen to be a thin, thready one, and without any of the surrounding iridescence.

A thin spark may be caused by want of power in the induced current of the secondary winding of the coil. The causes of this may be faulty design of the coil, imperfect regulation of the trembler contacts of the contact maker, or insufficient current from the battery. It should be understood that unless the source of the current, namely, the battery, is in a condition to give a good current, the spark will be thin.

It must be borne in mind that the spark is larger under ordinary atmospheric pressure than it is in the cylinder, owing to the compression in the latter. The increased pressure and temperature affect its intensity, and allowance must be made for this. The points of the spark plug for magneto ignition

should be placed slightly closer together than in the case of high tension coil and battery ignition.

In testing the spark plugs of a two or more cylindered engine a more accurate determination of the power of the spark may be arrived at as follows: Take the wires off all plugs but one and ground by leaving them in contact with the engine and then turn the engine. Repeat this till the plug which will not run the engine on one cylinder is discovered. It is best first to loosen all the wires and start the engine up and then leave only one in circuit in turn. This can be readily done where chopper switches are used; though these are generally only fitted in the case of low tension magneto igniter plugs. (It is of the utmost importance that, where the test is made, the wire should be grounded, otherwise the coil or coils may be permanently injured.)

The usual defects which appear in working, and which will cause bad sparking are: Broken core, resulting in the spark penetrating the crack where the insulation is weak, and making a short circuit with the metal cover, instead of passing at the points. The crack is in some cases so small that the porcelain or mica core feels tight to the hand in its case, and it is only when the spark has to pass under compression that it will choose the shorter and easier way. Or the crack may require the road vibration to open it sufficiently to allow the spark to pass, which often results in intermittent sparking. The heat of the engine also will cause expansion, and the crack may consequently increase while in use and diminish when cold. A broken or cracked porcelain can sometimes be detected by holding the plug to the ear and giving the porcelain a twist. If a grating noise results it is a sure indication. A black deposit about the plug is also an index. If a nut or set screw securing the washer on the plug is overtightened it may crack the porcelain.

Sometimes there is a loss of compression at the packing gland, and it then becomes necessary to tighten up the hexagonal top of the circular portion of the gland. This may possibly affect the adjustment of the sparking points, which

should consequently be examined after the operation. Sometimes the thread of a plug is slightly burred in the fitting of the gap wire, and when screwed home the position of the wires may be altered. After screwing home, therefore, the plug should be unscrewed again and examined before being replaced.

Defective sparking at the plug will follow the accumulation of oil or water on the base of the porcelain or between the points; the latter is not so common as the former, but if it does occur it forms, being a good conductor, a continuous circuit for the electricity, and there being no gap, no spark will pass. On the other hand, oil is a very good insulator, and if there is oil on or between the points of the plug, there is considerable resistance to the spark passing. When the engine is at work, however, the oil is burnt, leaving a carbon deposit on the plug, and as carbon is, like water, a fairly good conductor, the electricity will travel along the surface of the plug instead of jumping the gap. In heavy rain, water may collect on the top of the bonnet and drop through on to the porcelain of the sparking plug, so that a big drop forms on its side and cause a "short"; or a blob of mud may be deposited thereon.

As the battery runs down the current will grow weaker, and therefore the points of the plug may need adjusting closer to each other to suit the altered conditions, but it is better to change or recharge the battery.

When every adjustment has been made to the plug, and the engine is still obdurate, a new one should be fitted, and if this does not mend matters the motorist may reasonably conclude that the battery has run down or that the coil is at fault.

(7.) **The Coil**—Coil troubles are difficult to diagnose. A "short" is generally indicated by a ticking or buzz inside the coil or by an excessive discharge of current causing rapid pitting of the contact points. The "short" may be due to a weak spot in the insulation, which may not manifest itself until the coil has been in use for some time. In case there should be such a weak spot in the insulation, great care should

be taken in testing the wires not to hold the end of the high tension wire more than one-eighth of an inch from the metal of the engine, for if this is done, the resistance to the current passing may prove so great as to break down the weak spot in the insulation.

Fig. 1 shows the ordinary form of trembler. A is the spring blade, and B is a weaker spring making contact with the screw C. E is the core of the coil, which, when magnetized by the passing of the primary current, attracts A and breaks contact with C. The core then becomes demagnetized, and the blade A springs back and B again comes into contact. The same process is repeated continually and rapidly during the time contact is made, resulting in a rapid vibration of the trembler and a great number of makes and breaks.

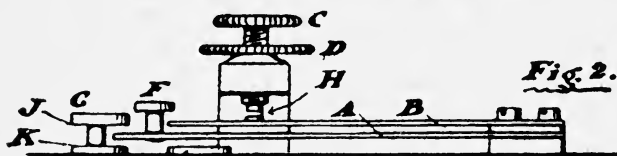
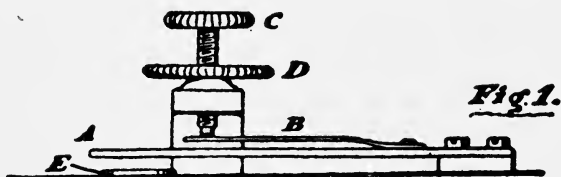

It is essential that the contact points between the trembler blade B and the platinum-pointed screw C should be properly adjusted (see Fig. 1). If the contact is too firm the spring cannot tremble, and only a weak spark results, whereas if no contact is made the current will not pass. The platinum-pointed screw should be adjusted with the engine running until the trembler gives a full and regular buzz. In a multi-cylindered engine it is essential that the note should be the same in every cylinder, or the timing in the different cylinders will vary and the engine will not give its full power. The platinum-pointed screw C having been adjusted, it is locked by the milled nut D.

Fig. 2 shows the trembler mechanism to be found in the well-known "Castle" coils. The adjustment of this is somewhat different. Instead of judging by the buzz, it is best to adjust this trembler as follows: The contact screw C should be screwed down until it makes contact with the spring blade B (the upper of the two blades in the diagram), and just breaks contact at its end with the under side of the button F (this is attached to the under or armature blade A). When the armature blade A is pressed down to the bottom of the button G, the clearance between the two contacts at H should be approximately half that between the bottom face K and the under top face J of the button G. This method of adjustment is that followed by one of the most experienced of European motor engineers.

Sometimes, with tremblers of the type shown in Fig. 1, the engine will not start until the trembler is vibrated by hand. This is due to the armature blade A being too far from the end of the core E—the magnetic pull being insufficient to attract A and so break contact between B and C. In that case the blade A should be very slightly bent down nearer the end of the core E, and the contact readjusted. This symptom, however—the trembler not having been previously interfered with—often points to a weak dry battery or a run down storage battery, which should be tested.

If misfiring should occur, the operator should turn the starting handle slowly, and note if there is a full buzz each time the segment in the contact maker disk comes under one of the brushes. If in any case there is no buzz, the wiring and terminals should be examined. If they are in order, the trouble must be in the engine, and the next course is to find the faulty cylinder. This can be done by cutting out all the cylinders in turn with the engine running, either by lifting the chopper switches, or by pressing down all but one of the trembler blades of the coil at the same time. The plug of the weak cylinder should then be tested, and if there is anything wrong, a new plug should be fitted. Excessive sparking at the contacts may be due to defective adjustment, to inferior

alloys in the contacts, or to failure in the condenser. If, after remedying the adjustment, there is no improvement, the contacts should be renewed with pure platinum. If excessive sparking still takes place, the best plan is to run the engine on a new coil. If the sparking then is not apparent, the owner may take it for granted that there is something wrong internally with the old coil, and should send it to the makers.

In testing a coil it is very necessary to see that when contact is complete in the low tension circuit, there is a metallic circuit for the high tension. This will be complete in the ordinary course with the exception of the gap across the spark plug points, which is not great, and which will allow the current to jump across when contact is broken at the contact breaker. If, therefore, in testing one or more coils on a multi-cylindered engine, the wires leading from the high tension winding of the coil are not connected closely to ground (by leaving the ends within one-eighth inch of the metal of the engine) a very high initial voltage will be induced in the coil which may break through the insulation and so may irreparably damage the coil. It is necessary, therefore, to see that each wire from each coil is either permanently grounded, or is held in close proximity to some metallic part of the engine or framework of the car. If the ends of the wires are held not more than one-eighth inch from some such metallic part, the spark across will indicate that the coil is working correctly. If the space is larger, the voltage set up in the coil will be such as to cause it readily to break through the insulation. Such a breaking of the current through the insulation of the high tension wiring in the coil produces a "short," and this may be detected often by a faint buzzing sound inside the coil as distinct from the trembler buzz. Damage to the primary winding of the coil may be readily detected by measuring the voltage of the current by means of a voltmeter placed in a circuit with the two terminals of the storage battery, and comparing it with the voltage registered when the voltmeter is placed in circuit with one terminal of the battery and one terminal of the coil, so that the current has to pass through

the coil before going through the voltmeter. Any internal defect in an induction coil is best remedied by the makers, as the ascertaining of the point at which the current is shorting or leaking is a very delicate matter. On some coils there may be as much as quarter of a mile or more of high tension wiring, in any part of which a leak may take place or a short occur.

Moisture or dirt on the coil terminals will cause short circuits, while extreme heat will permanently injure the coil.

If, when contact is made, the core attracts the armature, but refuses to release it when the current is stopped, the fault will lie in the coil core being to a certain extent permanently magnetized. The remedy for this is a new core of very soft iron, and it can only be fitted by an experienced coil maker. Sometimes, however, the effect of this can be got over by interposing between the blade and the end of the core, a thin strip of paper gummed on to the core. In cases where the blade has a soft iron armature attached to it which comes opposite the end of the core, this may become magnetized. If so, the interposed paper may remedy it. If not, the armature should be taken off the spring blade and annealed by heating it to a dull red heat in a fire and allowing it to cool very slowly in the ashes.

The surfaces of the two points—one on the blade and the other on the contact screw—should be kept quite flat and quite square; that is to say, when they come in contact with each other, the whole of their surfaces should come into contact, and not only one part. It is well-known that if a current passes across a gap, one side of the gap will have on it a piled-up accumulation of very fine particles of the metal taken from the other side of the gap. Thus one point will become convex and the other concave. The result is that a firm and even contact is not made, and misfiring may result.

From the foregoing it will be readily seen that by reversing the direction of the current occasionally, the reverse tendency will take place, and that point of the trembler which was giving metal to the other point will be taking metal back.

By occasionally altering the wires from the battery, so that the wire running to ground is sometimes a positive wire and sometimes a negative wire, this pitting of the points of the trembler will, to a very large extent, remedy itself. In the case where two batteries are used with a switch which can put either one or the other in operation, it is advisable to wire one up with the negative terminal connected to ground, and the other with the positive terminal connected to ground. If the user changes the switch over each day, so that on one day one battery is being used and on the other day the other, a reversal of the direction of current will be obtained, which will cause the accumulation of metal on one terminal to be sent back to the other terminal. This will keep the trembler in much better order, and prevent a great deal of unnecessary filing of the platinum points, which, of course, means loss of a very valuable metal.

In cases where the platinum point has to be filed in order to get a level bearing on the platinum point on the blade, an easy way to get the point square and flat is to screw back the platinum point in the bridge piece which holds it until it just protrudes below the under surface, and then to use the file under this, the bridge piece acting as a guide to the file. The screw may, meanwhile, be slightly turned.

In cases where it is difficult to get at the tip of the screw in this way, the screw may be taken right out, and a lock nut which is generally provided to lock this screw in position may be run on to it, and this may be used as a guide, so that the end of the screw may be filed up quite square.

The filing of the platinum tip on the blade is an easy matter. The blade should be laid down flat on a planed piece of wood, and then filed across. Filing the platinum contact on the blade while it is in position may have the effect of altering the position of the blade, in which case the adjustment of the whole trembler would have to be gone over again. For a quick cleaning up of the contact points between the trembler and blade a good plan is to double a piece of emery cloth of fairly fine grade, so that the emery is on the outside of both

sides of the cloth, and then to push this between the blade and screw backward and forward, keeping a certain amount of pressure on the blades, so that both platinum surfaces of screw and blade are kept in close contact with the emery. It is necessary afterwards to clean off all the particles of emery set adrift in the course of this operation.

Pitting of the platinum contacts in a trembler or in the contact maker of a magneto, or in the contact breaker on an engine using a high tension battery system of ignition, causes rapid deterioration of the surfaces and inefficient contact, sometimes resulting in misfiring and a weak spark. The reason of this pitting is simply an excessive spark between the contact points. It is to prevent excessive sparking at this point that the condenser is used. The condenser of an electric coil consists of a number of superimposed layers of tinfoil separated from each other by thin sheets of mica or paraffined paper.

The condenser is connected in a shunt between each side of the trembler. It may happen that a condenser becomes grounded, that is to say, the wire leading from one side of the trembler to the condenser is in metallic contact with some part of the frame or some other wiring which will lead it to the frame. In this case, of course, there will be no spark at the plug, because the current will find its way through the wire leading to the condenser and so to ground. On the other hand, it may be that the wire which leads from one side of the trembler to the condenser, or the wire from the condenser to ground, may not be making proper contact. In either case, of course, no current will be sent in to the condenser—the result being excessive sparking across the trembler points and consequent pitting.

The function of the condenser being to prevent excessive sparking at the contact points of the trembler, it is necessary to see that the condenser connections are properly made, but, in making any investigation as regards this, very great care should be taken, as only very light wires are led to the condenser, and it in itself is a most delicate arrangement and

very easy to upset. It is generally best to allow the coil makers—or the magneto makers as the case may be—to correct any derangement which may be found in condensers.

(8.) **The Dry Battery or the Accumulator** (Storage Battery).—Internal short circuits are not likely to occur in the case of dry batteries, the only trouble in this respect being through the running down of the battery. This is a form of trouble not hard to avoid. As regards storage batteries so-called, or accumulators, however, a short circuit can easily be made. It is generally due to the buckling of the plates, so that a positive plate comes in contact with a negative plate. This will practically “short” the whole of the battery, with the result that it will be rapidly discharged through its own plates. Buckling of the plates is due in most cases to either too rapid charging or too rapid discharging. Thus, if we connect the positive and negative terminals of a fully charged battery together, the discharge will be so rapid that it is almost certain that the plates will be buckled and touch each other. In testing a battery to see whether current is flowing or not, it is, therefore, necessary to use a voltmeter, so that the current has to flow through a resistance. Another source of short circuiting in a storage battery is the oxidizing of the brass terminals, and the spraying over of the acid through the vent holes. The acid in this case may often form a path for the current from one terminal to the other, which results in the cell becoming discharged. The best method of preventing this is to smear the terminals with petroleum jelly, having first thoroughly cleaned them and treated them with a solution of ammonia and water. Up-to-date batteries are now fitted with glass bulbs which allow the gases to escape, but at the same time deflect the acid sprayed, with the result that the acid falls down again into the battery. For the treatment of batteries which have lost acid through excessive spraying there are well-known methods.

In a great number of batteries, principally used for motor cycles, the electrolyte instead of being in the form of a solution of sulphuric acid and water, is made in the form of a

jelly or paste which will not spill out of the battery should it be turned on its side or at an acute angle. Generally speaking, a solution of water and sulphuric acid is the best for motor car purposes. To prevent the corrosion of the terminals of a battery and a consequent shorting of the current, rubber sleeves are now made which can be pushed back over the wires, and then when the wires have been connected to the terminals the rubber sleeve can be pushed over both wire and terminal, the rubber effectually preserving both from the effects of the acid. It is well to see that a terminal is screwed so that the wire cannot be moved freely round it, that is to say, that it is gripping the wire tightly. Sometimes a terminal will screw down and apparently be tight without gripping the wire. The remedy for this is to countersink the underside of the screwed bore of the terminal nut. In some cases a "short" in a battery is due to the paste falling down between the negative and the positive plate and so forming a short circuit. This can only be remedied by taking off the top of the battery and replacing the paste in the plate, a job which often means the complete pasting of all the plates, and one which can only be properly carried out by an expert battery maker or repairer.

A storage battery should always be kept in a place where it does not come in contact with any metal tools or accessories, otherwise a short circuit can easily be made by the tools moving about, and coming in contact with both terminals of the battery.

As regards a dry battery, once it is run down to five volts it may be taken for granted that it is useless for ignition purposes and should be replaced. This, of course, is in the case of a four-cell dry battery—each cell should represent 1.5 when new. It must be remembered that owing to the fact that a dry battery generates its own current by chemical action, its voltage will fall gradually, while in the case of a storage battery, the voltage will fall very suddenly indeed. Very few firms, however, now fit dry batteries. In most cases storage batteries are used.

Troubles with batteries will be found to be due principally to insufficient charging. They are sometimes left for long periods without charging and allowed to run down to nearly the discharged rate, but this is detrimental. A battery should never be allowed to become fully discharged, and its voltage should be kept as nearly constant as possible. It should not be run for long intervals without charging, and, in fact, the capacity and utility of a battery can be greatly increased if charged frequently and not allowed to run down too low. Too much reliance should not be placed on the reading of a voltmeter when attached to a battery. A voltmeter may easily show over 4 volts when attached to the terminals of a battery, but when this battery comes into use its voltage may drop suddenly below 4 volts; that is to say, it may be practically discharged.

When a storage battery is nearly run out, and then suddenly put into circuit, it may show a greater voltage than it actually possesses, and for this reason it is best to use a small glow lamp and to put this in circuit with the battery. If the glow lamp glows brightly for several minutes, it may be taken for granted that the battery is above 4 volts. If, however, it glows very dimly and gradually decreases in brilliancy, it may be assumed that the battery is almost run down. Practically all batteries used for electric ignition purposes on motor vehicles consist of two cells, each giving out just over 2 volts. When coupled in series, the sum of the voltage should amount to 4.5 volts, but it drops at once when put into use. If internal leakage is taking place between two cells this voltage will be lowered. It is, therefore, useful to check the voltage of each of the two cells in a battery by connecting the negative or positive terminal, as the case may be, with the cross bar which joins the two cells—thus putting one cell out of circuit. If a reading is taken when the voltmeter is connected to the cross bar and the negative terminal, and another reading is taken when the voltmeter is connected to the cross bar and the positive terminal, the sum of the voltage will be the voltage given off by the two cells—that is, the complete bat-

tery. If the two readings differ, internal resistance has been set up, probably due to a faulty connection on the bridge piece which connects the negative pole of one cell with the positive pole of the other. This can generally be ascertained by attempting to move the bridge piece relatively to the cell, and if it is not quite rigid, it may be taken for granted that good metallic connection is not being made.

Each fully charged cell should give off a voltage of 2.2, and the resultant voltage should be at least 4.4. In charging, the golden rule is—charge slowly, uniformly, and at frequent intervals. Fast charging leads to buckling and short circuiting of the plates. Slow charging at frequent intervals, before the voltage has dropped too low, improves a battery. It is, therefore, advisable to keep two batteries, and alternate them frequently, charging up the one not in use, while the one in use is being drawn upon.

As regards the running out of either a dry battery or an accumulator, in case a fully-charged spare one is not carried, and sufficient voltage cannot be obtained to run the engine, it is often possible to run on two run-out accumulators each of 4 volt capacity if they are coupled up in series; that is to say, the switch should be disconnected and the wires from each pole of the switch should be connected together so as to give a complete circuit. The ground wire should be connected to the negative terminal of one accumulator; the positive terminal of this accumulator should be connected to the negative terminal of the other, and the positive terminal of the second accumulator should be connected direct to the electric ignition mechanism. In this way, an increased voltage can be obtained, and although the batteries may each show less than 4 volts, the combined voltage will be sufficient to induce—temporarily, and only temporarily—sufficient high tension current in the secondary winding of the coil. It must be distinctly understood, however, that this connection should only be made when the batteries are partially run down. If the connection is made when the batteries are fully charged, as much as 9 volts will be sent through the coil. The result will

be such an enormously high voltage in the secondary winding of the coil that it may become permanently damaged through not having sufficient insulation to carry the voltage set up.

In the case of dry batteries, if there are two, the same procedure may be followed, coupling up the two batteries in series after they have fallen below 4 volts or each set of four cells. When accumulators are nearly run down, their voltage cannot be increased except by coupling up in series in the way we have pointed out. In the case of dry batteries, however, they may be to a certain extent re-energized by making a hole in the pitch with which they are sealed and pouring in a solution of warm water and sal-ammoniac—only such a quantity of sal-ammoniac being dissolved in the water as will leave the water clear. By leaving the sal-ammoniac in the warm water for about an hour and then draining off the water, all the sal-ammoniac which the water will hold in solution will have been absorbed, and the solution will then be as strong as possible. In order to rapidly get the solution of sal-ammoniac into the cell, it is advisable to make the hole through the pitch sealing large enough to admit a small quill; the solution can then be poured in, and the quill will allow the air the necessary exit. A quill from any chicken, cut so that it is open at each end and the finer the better, will be suitable. It should protrude about one thirty-second of an inch below the bottom layer of pitch. After the new solution has been poured in, the cells should be sealed up. This could be done in case of emergency by a hot iron, which will melt the pitch and cause it to flow again and close the hole made for the introduction of the solution. The cell will then revive, and its full voltage may be availed of, but it will only be useful for a short period of time, and will very rapidly run down, when it will become useless. It is always advisable to have a spare battery ready at hand.

In cases where leaks take place in accumulators due to the breaking away of the celluloid cases, these can be repaired by taking out the acid and using celluloid sheet and cellu-

oid repairing solution which can be obtained from most of the makers of such batteries.

MAGNETO-IGNITION TROUBLES.

So far we have dealt with repairs and adjustments to high tension ignition where a storage or dry battery is used to provide the low tension current. In the case of magneto ignition, and considering high tension magneto first, we may take it that those troubles which occur in distributors, contact makers, and contact breakers, will be practically the same in the case of this type of ignition, and therefore we may refer, for troubles as regards these units, to our previous notes on high tension ignition. In the case of low tension magneto ignition, the troubles will generally be found to be purely of a mechanical kind, and will be dealt with as we come to them.

Before reading this section, the reader is advised to carefully study the question of magneto ignition as it appears under the general heading of Ignition, which deals with both high and low tension magneto ignition.

(a) **The Low Tension Magneto System.**—This is the most simple of all types of magneto ignition, seldom requiring any repairs or adjustments to the magneto itself, this instrument simply consisting of a rotating armature with a coil round it and some form of wiper to carry off the current. The principal faults and troubles which arise in this type of magneto ignition will be due to the mechanical make-and-break mechanism of the timing gear, to which we will refer later. There is one point, however, which it is necessary to emphasize; the armature bearings should be kept lubricated, but excessive lubrication should be avoided, as this soaks into the insulation, and is liable to set up short circuits in the armature. It also attracts dust and dirt and may cause a "short" between the end of the wiring of the coil and its connection to the armature ring. Where ball bearings are used, a few drops of oil every two or three hundred miles will be sufficient. Where the bearings are of the plain type, there is generally a felt wiper which presses against the armature spindle and is held

in a tube which terminates in an oil cup cast as part of the bearing. The oil is fed up from the oil cup by capillary attraction. In these cases, it is only necessary to fill up the oil cup on each side occasionally, and to drop one or two drops through the small hole which will be seen leading directly to the bearing. The felt wipers can generally be removed from underneath by undoing one screw and taking out a small spring which presses them up to the spindle. In time they may become congealed with thick oil, and should either be replaced or washed with gasolene, so that the oil can flow readily up through the interstices of the felt.

A contact maker or wiper is used in low tension magnetos to take off the current from the coil and lead it by a wire to the igniter plugs. This is usually a cylindrical carbon pencil, which is pushed down by a spring, its end coming in contact with an insulated ring rotating with the armature. The wiper is in contact with the insulated ring to which is led one end of the low tension wiring of the armature. This should occasionally be taken out, and if it appears to be glossy at the end this may be scraped with a penknife, or preferably ground slightly on a grindstone or even on a piece of coarse emery cloth. The insulated ring should be kept clean, and surplus oil should not be allowed to accumulate upon it. In some cases where the current taken off is intermittent or appears weak, it is well to take the armature out, and thoroughly clean the insulated rings, as sometimes a very fine carbon dust (caused by the disintegration of the end of the carbon wiper, owing to the rotating against it of the ring) is formed, and may cause a slight short circuit, especially when run at low speed. This is often the cause of difficulty when starting, as when the engine speed increases, the higher tension current finds its way by the metallic connection to the plugs, and will then fire apparently all right. Troubles with any magneto may be caused through allowing water to get into it, due to carelessness when washing down the car, or allowing the car to stand in rain with the bonnet off or open. The best remedy for this is to take the magneto off the machine, carefully

marking the coupling to see that it be put back in the right position to insure correct timing, and to place it near a fire or in a very dry room to dry. It must not, however, be placed too near a stove or the insulation will be ruined, and the armature will have to be rewound. We have heard of one case where a magneto which had been sparking badly on account of being thoroughly wet, had been cured by pouring wood alcohol round the armature bearings and the wipers, but this is a drastic remedy which must only be undertaken by those who know how much to apply and where to apply it, otherwise the shellac insulation will be ruined. The idea of using alcohol for this purpose is that it carries the water away with it, and leaves the appliance dry.

A short circuit may also occur in the wiring leading from the magneto to the igniter plugs and even in the igniter plugs themselves; or it may be due to some fault in the wiring between the igniter plugs and the switch which grounds the current in order to stop the operation of the engine. In the latter case disconnect this wiring at the engine, and then see if the engine runs properly. It may be found that the trouble is somewhere in this wiring or in the switch, which thus grounds the current and interferes with the inductive effect of the magneto.

Sometimes intermittent firing when the car is running is caused by some exposed part of the switch wire swinging about, and coming in contact occasionally with some part of the car frame or steering gear. The test for this is the same as in the last instance. Sometimes the engine will not stop when the switch is operated. In such cases the fault is that there has been a breakage in the wire or connection of the switch, so that the magneto cannot be grounded upon itself. Another short circuit which will stop the engine is that between one of the igniter plugs and striker arms; that is to say, instead of these making a contact only immediately before the correct timing contact is made, the arm goes back into contact immediately after the rapid break and remains there

—thus grounding the magneto at the time that other cylinders should be firing.

This can be ascertained by disconnecting all the cylinders, except one, in rotation, that is to say, leaving only one cylinder plug in metallic connection with the magneto. The one on which the engine will run when the others are put out of operation is the one which is in contact for too long a period. We will deal with this adjustment when we come to the timing of the low tension igniters. As pointed out, a "short" in the low tension system is not so likely to occur as in the high, owing to the fact that the current has not got sufficient pressure to force it through weak insulation. Therefore, the insulated wires for low tension magneto may have less insulation on them.

As regards the igniter plugs, short circuits may occur in these just the same as they may occur in the high tension spark plug, due to wet deposit outside the mica or porcelain insulation, or due to carbon deposit, which, forming a layer allows the current to flow across the deposit from the central insulated stem to that part of the plug which is screwed into the engine. The remedy is to take apart, and thoroughly clean the insulation of the plug.

Troubles in this kind of ignition are almost always due to the wrong timing, and it will be well for the motorist to secure full instructions as to setting the interrupter arms, contact arms, and the interrupter catch gear, as the case may be, and according to the different systems of the arrangement of the mechanical parts.

Another cause of loss of power due to this ignition system is that the working shaft on which the contact arm is mounted and which passes from the outside into the inside of the cylinder does not make a proper joint in the hole in which it fits. On earlier cars, considerable trouble was caused here, with the result that loss of compression, and hence loss of power, was found to take place. Latterly, however, by arranging these with ground tapered heads, this difficulty has been to a large extent overcome, but when the trouble ap-

pears it is only necessary to take off the whole of the igniter mechanism from the engine, and to carefully grind in the seating of the contact arm. The contact arm is drawn up into this seat generally by means of a spring outside, and if this gets weak, it may allow a slight loss of compression, and should be replaced by a stronger spring, but if the joint is good, the pressure of the gases inside the cylinder itself will maintain good contact and make a tight joint. The spindle of the rocking lever must be kept lubricated constantly, and should it wear oval, must be replaced.

The contact between the end of the contact arm and the igniter plug should be firm. For this purpose it is necessary to see that the springs which hold it up against the igniter plug are strong enough for that purpose.

(b) **The High Tension Magneto System.**—As regards the high tension system, and dealing first with the magneto, any trouble which may arise as regards short circuits or leakages will practically be the same as in the case of high tension coil and battery ignition, as far as the wiring is concerned. In the high tension magneto mechanism, trouble will more likely be caused at the contact breaker than at any other point. Sometimes, excessive pitting takes place between the platinum points of the contact breaker, and this excessive pitting may indicate something wrong with the condenser connection.

In the high tension magneto machine the condenser is always made to form part of the mechanism. It is generally arranged in a little box on top of the field pieces. One side of the contact breaker is grounded in the usual way, and between the ground and the positive side of the contact breaker—which leads the current off to ground only when the points are in contact—there is generally a wiper which connects up the positive part of the contact breaker to the condenser. The condenser is grounded at its other end to the magneto itself. If this wiper is not making proper contact with the insulated ring, the result will be that the current shunted into the condenser is insufficient, and excessive sparking will take place at

the contact breaker points. This may be due to the wiper, or the insulated ring upon which it wipes, being dirty, either through dust off the carbon brushes or foreign matter. In some cases, but very rarely, the wire which connects up the insulated ring may become detached. This is generally a very thin wire, and may be easily soldered up. A thorough cleaning of the condenser wiper will probably put things right, which will be indicated if the spark at the contact breaker points appears to be reduced.

Another difficulty which may often be traced to this connection to the condenser is that some part of the mechanism containing the spring-pushed wiper may have got adrift. This is always insulated from the body of the machine, and if anything gets loose this part may be put in metallic contact with it, so that the current, instead of going across the sparking plugs, runs to ground through the body of the magneto. The screws which hold the case carrying the spring-pushed carbon wiper should be thoroughly clean and have good insulation from the body of the machine. Sometimes the screws themselves will form metallic connection and effectually stop the operation of the magneto.

In cases such as the Eisemann, where the coil is a separate unit in the system, shorts may occur through bad connections from the magneto to the coil. The current for the magneto is taken off by a wiper, which should have the same attention as the others; that is to say, it should be thoroughly insulated, kept clean, and the ring upon which it presses should also be kept thoroughly clean and free from oil. The same remarks as regards an accumulation of fine carbon dust apply in this case, and this should always be cleared off. There is also a high tension wire, which is led back from the coil to the distributor on the magneto. This distributor is practically always of the wipe type. Its face, or its edge, as the case may be, should be kept clean, and care should be taken to see that the central wiper, which conveys the current from the coil to the rotating distributor, is making sound contact. In the case of the Bosch magneto, a safety spark gap

is provided, and it may happen that if by any tampering with the magneto the points of this safety spark gap have got too near together, it will be sparking to ground across these instead of across the plugs in the cylinders. This safety spark gap should never be tampered with, as the distance apart of the points (which are there solely for safety purposes and to protect the insulation from being broken down) is determined by the makers, and if left at the distance at which they are set it will be found that no cause of trouble will arise from this part of the mechanism.

The points of the contact breaker at the end of the magneto should always be carefully filed up so that when they are in contact they meet each other face to face and quite flat. It is best when adjusting these to first take note how they come together; then, having taken them apart, they may each be faced up with a very fine file. Where they are only dirty, a good way is to wash them with gasolene with a fine camel hair brush, then to insert between them a piece of doubled up fine emery cloth, and run this backward and forward so that it grinds against the face of both contact points. The emery should be brushed away, and the machine should not be run until the gasolene has evaporated, otherwise a flare-up might result. On no account should the magneto be run on the road with either distributor or contact breaker uncovered, otherwise dust and dirt are sure to accumulate and interfere with its working.

The same course as regards lubrication applies to the high tension as to the low tension magneto, with the addition that in this case the secondary shaft, which carries the distributor disk or arm, should occasionally be oiled, as should also the gear wheels by means of which it is driven. In the case of the Eisemann using the helical slot method of retarding and advancing the ignition, it is necessary that this should be kept clean and oiled, otherwise this part of the arrangement will work very stiffly, and may cause injury to the magneto. Where the high tension distributor has carbon brushes rubbing against a segment or segments on a rotating disk, it is

necessary that this should be kept quite clean. Sometimes small particles of brass are rubbed off and become embedded in the vulcanite or fiber of which the distributor disk is made, causing a "short" across which may result in premature firing of one or more of the cylinders and misfiring at high speeds.

All carbon wipers should be periodically taken out and allowed to soak in gasolene to dissolve any oil with which they may become impregnated, and they should then be cleaned up with sand-paper or by very slightly grinding as mentioned before. It should be noted, too, that the springs which push them down are of sufficient strength to keep them in close contact with the ring. The segments of the high tension distributor in the latest type of magneto are coupled internally to the terminals on the top of the face of the machine. As a matter of fact, they are generally embedded in pitch. It is unlikely that any leakage can occur here, but care should be taken that the connections between the terminals and the high tension wires leading to the plugs are very carefully made, and it is a good plan when rewiring up after discovering the fault, to convey the wires back in a piece of rubber tubing, which will prevent them coming in contact with, or being rubbed by, any part of the mechanism.

In making any adjustment to the magneto, it is inadvisable to screw any of the parts up too tightly—just handtight with a small screwdriver is sufficient. The vulcanite plugs carrying the carbon brushes screwed into the edge of the distributor or the small brush which takes off the high tension current from the ring, should just be screwed in tight with the fingers, and, although they have flats on them in many cases, it is unwise to use a spanner to screw them up, as if they break in place they will be difficult to remove, and will have to be replaced by new ones.

As regards timing, a few words may be said here, although the subject is one that can hardly be treated with justice in the limits of the present work, and it is of surpassing importance. Where magnetos are driven from the engine by inclosed gearing, it is almost certain that, unless the en-

gine has been tampered with or the magneto removed by some person who does not understand it, the timing will be correct. In any case, it is not advisable for the amateur to interfere with the relative positions of the magneto armature and the engine crankshaft. Experimenting in this direction may result in his being unable to get any firing in the engine at all. This applies to both the high tension and the low tension magneto as regards the time at which the armature leaves the field. In the case of the high tension magneto the timing of the breaking of the spark relative to the armature position is constant in one form of Eisemann, while in the latest, and in the Bosch, the contact breaker can be rocked over just in the same way as the contact breaker on an engine. This, however, need never be interfered with. On no account should the operator disconnect the two wheels—the small one on the armature shaft and the large one on the distributor shaft—by means of which the latter is driven. These are delicately adjusted, so that at the central position of the ignition lever the distributor is making proper contact to the respective plug which is to be fired.

Another point to be noted is, that if the wires be disconnected from the engine and from the magneto, very great care should be taken to put them back to the same terminals on the magneto and the same plugs on the cylinders. If they are put back in wrong order and the engine started up, very serious damage to the engine may result.

In a late Simms magneto, looking at the terminals from the front end, which is the distributor end, and when it is rotating clock-wise, the one on the extreme left is taken to the cylinder nearest the dashboard; the one to its right is taken to the cylinder nearest but one to the front of the engine; the next one to the right of the magneto is taken to the front cylinder of the engine; and the last one on the right is taken to the cylinder nearest but one to the dashboard, the cylinders thus firing in the following rotation:

Front cylinder, 1st; third cylinder, 2nd; fourth cylinder, 3rd; and second cylinder, 4th, counting the cylinders as 1,

2, 3, and 4 from the front of the engine. This applies solely to a recent Simms magneto for four cylinders, and is mentioned only by way of illustration.

Faults due to wrong timing in the low tension magneto system are invariably due to wrong adjustment of the tappet rods, the striker arms, and the igniter mechanism.

PREIGNITION, OR TOO EARLY FIRING.

Symptoms: Knock in engine.

Causes: Faulty timing.—Ignition too far advanced.—Overheating.—Excessive lubrication causing sooty deposit which becomes incandescent.

Preignition results in the charge being exploded before the piston has reached the top of the cylinder, and so causes a back pressure on the top of the piston, tending to reverse the direction of rotation of the crank.

A knocking noise in the cylinder generally betokens too early firing. (See Knock.)

The causes may be described under the following heads:

(a) Timing gear set wrong.—This is dealt with very fully under Timing.

(b) Faulty manipulation of the sparking lever.—The position of the sparking lever should be regulated according to the speed of the engine. To take two extremes: When operating the starting handle the piston will move very slowly, consequently if preignition is to be avoided the spark should be retarded as much as possible. On the other hand, when the car is traveling at top speed on the level or down a slight incline, the engine will be working at its maximum speed, and the spark should be advanced to the utmost. This is an important point to remember.

(c) Overheated engine.—This may cause the charge to explode prematurely, due to deposits of carbon in the cylinder or on the piston becoming incandescent. (See Overheating.)

Preignition may also be caused through faulty adjustment

of the ignition mechanism, such as the magneto, the contact breaker, and the distributor. These adjustments are all dealt with under Ignition.

KNOCK.

Symptoms: An unusual noise in the cylinder or bearings like a knock or hammer blow.

Causes: Ignition advanced too much.—Preignition.—Short circuit at contact maker or contact breaker (low tension system).—Timing wrong.—Overheated engine.—Want of lubrication.—Unsuitable oil.—Some part loose or broken.—Connecting rod or crankshaft bearings loose or worn.—Loose or worn piston pin.—Loose flywheel.—White metal linings of bearings melted out.

A "knock" may be technically described as an unusual thumping noise, which denotes that something is loose which should be only a moving fit in another part, and is quite distinct from that attending the regular pulsations of the exhaust or the mechanical movements of the valves and their operating gear. Incorrect firing is a very usual cause. In every engine there is an intimate connection between the speed of the engine and the most suitable moment for firing the gas charge. If the firing is made to take place too early for the speed of the engine the gas will be ignited before the piston has passed the top dead center, and a violent thumping will be caused, with much strain on the piston pin, connecting rod, and crankshaft bearings. The engine will, in consequence, labor, as the tendency will be—if the firing be very premature—to reverse the engine's motion, consequently its speed will be seriously checked, and unless the cause be at once removed by retarding the ignition, the thumping will become more pronounced as the speed of the engine diminishes. This trouble is especially noticeable in governed engines, when the accelerator is not operated in the same proportion as the firing is advanced. The effect then is that the speed is checked by the governor, though the firing is taking place in accordance with the position of the ignition lever.

A noise very similar to knocking occurs when an engine

is put under too great a strain on an up-grade. This should always be regarded as a sign to change on to a lower gear.

Apart from the faulty manipulation of the ignition lever, the timing may be fixed wrongly or may not be properly synchronized for the different cylinders. This is fully dealt with under Ignition.

A short circuit at the contact maker will cause a knock by premature firing in the cylinder affected. The presence of much carbon on the piston head, or in the combustion chamber, will also cause premature firing; the same applies to the effect of running an overheated engine, which, if persisted in, may result in the piston or pistons seizing. It should also be borne in mind that in the matter of overheating, which causes premature firing by incandescence—as it is termed—some motors are more prone to the trouble than others. (See Preignition, in this series of articles.)

Want of lubrication, or the use of unsuitable oil, irrespective of the amount, are also possible causes of knock. Nothing is more fatal to the life of a motor than inattention to this point, and it should be remembered that though itself removable, the ill-effects produced on the moving parts will soon entail a substantial overhaul of the engine. (See Lubrication.

A knock may arise from mechanical causes, such as the looseness of the piston pin in its bearing in the piston, or the connecting rod bush, or the crank pin bearing on the same rod, or play in the bearings of the crankshaft; also from loosening of the flywheel on the crankshaft or in the case of inclosed flywheels from the same getting out of correct alignment. Occasionally, too, the bearings themselves become loose in the crank casing, due chiefly to the small feather, which secures the one half from turning in its bed, becoming loose or being sheared. When such occurs it is possible for the bearing to become badly scored, as the oil holes in the base chamber and the bearing will have ceased to be in line. Engines fitted with a forced lubrication system are not likely

to suffer this derangement; such can then only occur if the filter gauzes, or chamber, or main conduit become stopped. The mechanically-caused "knock" may be diagnosed by its being continuous, starting with the first impulse at the piston. It is especially harmful when it is in the up-and-down direction, or fore-and-aft in the case of horizontal engines. A certain amount of lateral or side play is negligible—a little is even necessary—but up and down play must be at once corrected, for the reason that the stress caused by such play, even if confined at first to the piston or crank pin, will soon play havoc with every bearing in the engine, and the effect is intensified by the hammer-like blow due to the violence of the firing impulse which accompanies it. The crank pin bearing is usually the first item to develop a knock. In cases where the big ends of the connecting rods are lined with white metal, lack of lubrication may cause them to become so hot that the metal will melt and run out. After this has happened, the engine should not be run until the bearing has been re-lined and scraped by a competent engineer's fitter.

Loose bearings in the gear case, or otherwise connected with the transmission, or the slackening of a bolt, such as those that hold the two halves of the gear case together, may cause a noise somewhat resembling a knock. This trouble can often be diagnosed by touch, as it is accompanied by a certain amount of vibration, and generally increases with the speed of the engine.

A remedy for knocking, where the trouble is the piston pin, is to fit a new bush in the small end of the connecting rod. This bush should fit very tightly in the connecting rod end, and, after having been placed in position, should be properly drilled for the lubricating hole. It should also be provided, on its upper surface inside, with a groove to allow the oil to flow freely along the whole length of the bearing. If the knock is due to the piston pin being loose in the piston, it will have to be replaced by a new one. A knock at the big end of the connecting rod is generally caused by the brasses wearing, or in some cases may be due to the holding up bolts

coming loose. If the latter, tightening up the bolts will be sufficient. If the former, the brasses must be taken out and have their edges carefully filed so as to bring them into closer contact with the crank pin. In such case, however, it will be necessary to scrape the bearing surfaces until they are a correct fit, so that the connecting rod can be easily moved by the fingers around the crank pin without any tendency to bind, or, when the holding up bolts are tightened, to shake.

As regards the knock which is the result of slackness in the main bearing of the crankshaft, this means the refitting of these bearings, which must be done by a competent fitter and cannot be undertaken by the ordinary owner. Knock technically denotes looseness in reciprocating parts or parts which have to bear a strain first in one direction and then in another. Other noises which are easily distinguishable from knock are dealt with under Noise in this series of articles.

LEAKS.

Symptoms: In the case of failure of gasolene to reach carbureter rapid falling of gasolene level in float chamber.—In the case of pressure fed tanks failure of gasolene to reach carbureter owing to air leakage.—Engine overheats; bearings become hot; loss of power; sluggishness.

Causes: In gravity fed carbureters leakage in supply pipe to carbureter or shaking loose of bottom cover to strainer in carbureter.—In pressure fed carbureters leakage of air pressure either in air pipe from exhaust or from the tank itself.—Leakage of water in water circulation.—Leakage of oil in cases of forced feed lubrication.—Oil relief valve not acting.—Air relief valve not acting.

Leaks may occur of gasolene, water, or pressure (air or exhaust gas), and are some of the most annoying troubles of the motorist.

Gasolene.—Failure in pipes, connections, or the fuel tank will cause a leak. The soldering iron can safely be used. In the case of unions or connections, leather or fiber washers will generally get over the trouble. A faced joint can be temporarily repaired by thickly smearing the two faces with

boiled linseed oil before putting together. To make a permanent job the joint should be refaced.

A leaking packing joint can sometimes be staunched by tightening up the holding bolts, the first to be tightened being those nearest the leak, but unless the joint is in an awkward place it is better to put in a new packing.

Coupling joints should make a true and tight joint without packing, but if this cannot be done a thin fiber packing washer may be placed between the ends of the pipes to be joined. If the leak is behind the coupling nut, a little asbestos string wound round the end of the pipe close to the flange before the nut is slipped into position will often prevent any leak.

Any packing used for the gland of a pump should be well greased with tallow before being put in the stuffing box.

Water.—Leaks in the water-cooling system are always annoying and should receive prompt attention.

Pressure.—Escape of pressure from the cylinders is dealt with under Compression, in the pages that precede. In the case of pressure feed, the pipe conveying the pressure from the exhaust may be faulty, the pressure valve may be out of order, the cap of the tank may not be a true fit, or the exhaust pressure pipe may be choked; the latter failure cannot be described as a leak, but it has the same effect.

In the case of forced lubrication, if a leak occurs in any part of the circulating system, it will seriously interfere with the proper lubrication of the part. It may happen that a union becomes unscrewed through vibration, in which case the oil will be forced out there instead of being circulated round the bearing, and overheating and other troubles will ensue. The remedy, of course, is to periodically examine the oil circulating system, and see that all unions are screwed up tight. In some cases of forced lubrication, there is a relief valve which allows the oil, after a certain pressure has been reached, to flow back into the sump. It may happen that this valve leaks, in which case, although everything is apparently going on all right, the pump will be drawing oil from the sump and returning it to it, instead of causing it to flow round through

the bearing as intended. It is necessary, therefore, to see that there is no leak in this valve.

LUBRICATION.

Symptoms: Overheating.—Car runs sluggishly.—Engine misfires.—Smells.—Piston sticks or seizes.—Bearings seize or become scored.—Smoke from exhaust.—Noise and heat.—Worn bearings.—Warm bearings.

Causes: Faulty lubrication.—Wrong consistency of oil.—Pipes choked.—Relief valve sticking.—Relief valve spring too weak.—Oil pump spindle sheared.—Oil pump drive broken.—Particles of metal in the oil.

The troubles which are likely to arise from inattention to proper lubrication are dealt with below.

The theory of lubrication and the various methods employed make an interesting study for the motorist and one well worth his time to undertake.

The following are the vital points to be made a careful note of:

Correct quality. (See Lubricating Oil.)

Correct viscosity. (See Lubricating Oil.)

Correct quantity.

Lubricate copiously at first.

See that the supply is maintained in the crank chamber.

See that the oil is flowing properly through the lubricators, and, if not, clean the pipes.

If pressure fed, see that the pressure is not escaping.

Keep the grease pots filled.

Carry a reserve of oil.

In air-cooled engines trouble may arise through using an oil of too low a flash-point and of insufficient viscosity. This may result in overheating of the engine and even in the seizing of the piston. In the case of a seized piston either in an air-cooled or a water-cooled cylinder a remedy is to apply gasolene or kerosene and allow the engine to cool, when very often the piston may be freed by turning the starting handle.

In modern motor cars water-cooled engines are principally used—with one or two notable exceptions—and lubrication

methods have been wonderfully improved. Should it be noticed, in the case of sight feed lubricators on the dashboard where bucket chains or similar contrivances are used, that the oil is not dropping through the sight feed, it will often be found that the belt or other connection by means of which the lubricator is driven has become broken or otherwise inoperative. The remedy, of course, will be to rejoin the belt, or if it has been lost, to fit a new one.

Trouble with lubrication may be caused by using a thick oil in cold weather so that it is of too great viscosity at the low temperature to allow it to drop freely through the sight feeds. Generally speaking, a thinner oil is preferable for use in winter and a heavier oil in summer. In those cases where the oil tank is heated either by a by-pass from the exhaust or by being put under the bonnet and very near the engine, the precaution of using different oils for different temperatures becomes unnecessary.

Drip sight feed lubricators should be cleaned out periodically. A good method is to fill up the oil tank with kerosene instead of oil, and rotate the engine by hand so as to circulate kerosene through all the pipes, which will have the effect of cleaning them. The kerosene having afterward been thoroughly drained out, a proper lubricant can be substituted. Sight feed lubricators should be adjusted to give a faster feed when the engine is new—say for the first 500 miles—after which a lesser quantity will be sufficient.

In the case of pressure fed lubrication where an engine-driven pump forces the oil from the sump in the crank case to the various bearings, it is necessary to see that all the pipes are clear, and that each bearing is getting its due amount of oil. This can be ascertained by undoing the unions which couple the pipes to the "leads" inside the crank case and then rotating the engine, when it will be seen whether the oil flows through each of the pipes.

In case there is any obstruction, it may be generally cleared by attaching a tire-pump and pumping air through at high pressure. In this system of lubrication there is a relief valve

so that, when the engine is running at a high speed, the resistance to the flow of the oil and the work which the pump has to do is relieved by allowing some of the oil to flow back through a spring-pressed valve into the sump. If this valve gets stuck up so that it does not open, considerable strain may be put on the pump and its driving mechanism when the engine speed is accelerated, and the spindle may even shear, in which case the lubrication will be stopped altogether. Where the pump is driven by a flexible connection, the spring may break and the pump become inoperative. It is well, therefore, to occasionally clean out the relief valve.

If the spring of the relief valve becomes weakened the valve may open at a very low oil pressure, and the oil may be returned to the sump rather than being forced through the lubricating system. In such a case the bearings of the engine will suffer, and the lack of sufficient lubrication may not be noticed by the driver until considerable damage has been done. In this system of lubrication it is the general practice to fit a manometer, or pressure gauge, in some part of the circulation between the pump outlet and the engine bearing. This will give a reading as regards the pressure of the oil being forced to the engine, and if this pressure fails it may be taken for granted that there is a leak somewhere between pump and pressure gauge, and in most cases it will be found that this leak is due to a weak spring in the relief valve, allowing the oil to flow back to the base chamber. On the other hand, if the manometer needle reaches too high a pressure, it is an indication that there is a stoppage in some of the circulating pipes, and that the oil, instead of flowing to the bearing, is going back to the sump via the relief valve.

To ascertain whether the pump is working properly, it is only necessary to uncouple any of the "leads" from the pump to the crank case and to rotate the engine. In those cases where a by-pass from the exhaust causes pressure on the top of the oil in the tank and so forces it through the sight feeds to the engine, lubrication may be stopped completely by a leakage. This leakage may be due to unions becoming loose

or to the spring of the air relief valve becoming weakened. It will be denoted by the failure of the oil to flow through the sight feed glasses. On the other hand, if with this type of lubrication the oil pours through the glasses when the needle valves are set at their normal position, it may be taken for granted that the relief valve is not working, and that there is too much pressure on the top of the oil, causing excessive lubrication, which will result in overheating and carbonizing in the cylinder, and possibly subsequent misfiring due thereto. The remedy is to take out and adjust the spring-controlled relief valve, which is usually provided with a thumb nut adjustment. This valve may require grinding on its seat, the result of becoming pitted by the exhaust gases which pass through it.

The lubrication of the clutch is dealt with under the heading Clutch.

Trouble may arise from want of, or improper, lubrication in the gear box. The automobilist will naturally follow the instructions of the makers as to the height of oil and the nature of the oil to be used. In most modern cars the bearings of the gear box are lubricated from the sight feed lubricator on the dashboard in the same way as those of the engine, and this extends also in many cases to the differential gear. There are draw-off plugs at the bottom of the gear box and the differential box, and there are also plugs usually in the side of both these boxes to enable the user to fill up to the correct level. It may often happen however that, when fitting up, if the oil used is very thick, it will pass the overflow plug and owing to the gear box being practically air-tight, the oil will not flow out. To guard against this, it is necessary, when filling up, to take out the overflow plug first and to fill up very gradually so that the oil can flow through the overflow plug hole immediately it rises to its level; allowing the air to come in to take the place of the outflowing oil. If there is any doubt as to the level of the oil being higher than the overflow hole, this may be tested by inserting through the overflow hole a short curved piece of thin copper tubing. This

will allow the air to enter the top of the gear box, and if the oil then flows, the operator may know that there is too much oil in the gear box. A similar result may be obtained by loosening the bolts which hold the cover on and allowing the cover to open slightly to let in the air.

Lubricating pipes often become broken owing to vibration. In such cases they may be temporarily repaired by pushing over their adjacent ends a piece of rubber tubing and binding it with copper wire. They may afterward be permanently repaired by sweating or soldering a sleeve of copper tube over the broken ends.

The oil in the gear box will naturally become impregnated with fine particles of metal due to wear on the gear wheels. The quantity of this will be abnormal if the motorist is not skillful in changing gears and allows the gear wheels to grind against one another. As these particles of metal will act as an abrasive on the bearings, it is necessary to very frequently clean out the oil from the gear box. This oil may be used again if it is filtered. Oil filters are to be had which completely filter the oil and leave it in a condition to be used again in the case of gear boxes and differentials. An efficient filter may be made by using fine linen, allowing the oil to gradually soak through this into a vessel underneath. In the case of the engine it is not a good practice to use the oil over again owing to the carbonization which will have taken place, but waste oil from the engine may with advantage be used in gear boxes. All working parts should be well lubricated as described under Overhauling.

The joints at the end of a propeller or universal jointed shaft should be incased in leather and stuffed with grease. The same applies to the joints of the connecting rods and links of the steering gear. The method of fitting these steering gear covers so as to attain the twofold object of efficient lubrication, and keeping the parts together in case of a failure in the pins or connections, is described and illustrated under Steering.

Sufficient attention is seldom given to the lubrication of

the springs. The springing of the car will be greatly improved if there is proper lubrication between each lamination of each spring. The best way to lubricate these, where proper lubricating devices are not fitted, is to jack up the body of the car, leaving the wheels on the ground and lifting the body high enough to take all weight off the springs, or, in fact, to slightly extend the springs instead of compressing them. The end of each lamination may then be pried open with a sharp chisel, and grease lubrication can be applied between them by using a thin palette knife. The lubrication of the wheels should be carried out as described in Overhauling.

MISFIRING.

Symptoms: Explosion.—Loss of power.—Foul exhaust.

Causes: Ignition.—Short circuits in wiring terminals, plug, switch, distributor or battery.—Battery run down.—Coil defective.—Dirty or faulty plug.—Contact maker blades not making firm contact, or vibrating too slowly.—Brass segment in disk scored or worn.—Fiber swollen.—Terminals loose or dirty.—In low tension magneto ignition, contact arm wrongly adjusted.—Broken or weak spring on striker arm.—Short in igniter or wires.—Faulty switch.—In high tension magneto, short in wires or switch, contact breaker, or distributor.

Carburation: Dirt or water in carbureter.—Insufficient charge.—Jet choked, of insufficient bore, too large, or frozen.—Filter choked.—Float punctured.—Valve spindle bent or worn.—Leakage of pressure, pressure valve not set properly or sticking (in the case of pressure feed).—Vacuum in supply tank through want of air inlet (in case of gravity feed).—Insufficient supply of hot air.—Displacement of carbureter so that float touches side of float chamber.

Misfiring is caused by a failure to explode the charge, and is generally indicated by sluggish or jerky running, loss of power, explosions in the muffler, foul exhaust, sooted plugs, and even stuck up valves. The causes are many, but as they are nearly all dealt with under other headings, we shall only deal briefly with the subject.

As regards the troubles tabulated, loose platinum tips in contact maker and a defective coil are the most difficult to

diagnose. If the trembler spring is too stiff, the duration of contact at high speeds will not be sufficient and misfires will result. If missing only occurs when the sparking is advanced it will often be found that the battery is run down or the coil defective. Very often trouble is caused if the sparking points are too far apart. If there is too short a make before the break in the primary circuit misfires may result. General instructions on Ignition and Carburation, and those on "Ignition Troubles" and "Carburation Troubles" in the pages that precede should be carefully read, for any failure under these heads may cause misfiring.

MUFFLER TROUBLES.

Symptoms: (1) Explosions. (2) Loss of Power. (3) Rattle.

Causes: (1) Shorts.—Insufficient current.—Switching off and on.—Sooted plug.—Bad carburation. (2) Muffler choked. (3) Plates inside muffler loose.

Misfires are the most fruitful source of muffler troubles. These generally happen through the ignition being faulty and an unexploded charge getting into the muffler, which the next exploded charge ignites. A sooted or faulty plug, an exhausted battery, or wrong adjustment of the coil tremblers, are the most usual causes. If the engine is stopped by switching off the current, or if the current is switched off temporarily while running downhill, an unexploded charge may be left in the muffler, and get ignited when the engine is restarted. In some cases the end of a muffler has been blown out through this. Bad carburation is also a fruitful source of explosions. (See Misfires, Short Circuits, and Carburation Troubles.

Loss of power is frequently caused by the muffler being choked with a heavy deposit, due to over-lubrication. The muffler must be dismantled and cleaned. In some cases the deposit must be burnt out. The exhaust pipe also may be partially choked, and should be cleaned.

A split muffler or failure in the exhaust pipe packing will cause a noise, which sometimes is sharp and almost metallic,

and at others more of a hissing or puffing nature. Loose nuts or loose exhaust pipe unions may also cause the same effect.

NOISE.

Symptoms: Knocking noise as though two parts were violently hitting each other.—Grating or grinding noise, as though two parts were grinding against each other.—Rattle of parts generally.—Hissing noises as of escape of air or gas.

Causes: Knocking due to looseness in the connections of the reciprocating parts and almost exclusively confined to the engine. (This is fully dealt with under "Knock" in this series of articles.)—Grating or grinding noises due to insufficient lubrication.—Small parts and connections being loose.—Bad joints in air, gas, or exhaust pipes.—Bad joints between plugs and cylinder walls or valve covering caps.—Leaky compression cocks or their joints.

Noise is one of the most objectionable defects in a car, and as a noise of any kind in any mechanism not only denotes loss of power but also increased wear, every effort should be made to check noise which is considered abnormal.

Noise which denotes inefficiency in mechanism and engines may be divided roughly into three classes:—(1) Knocking, which is produced solely by improper impact between two or more parts; (2) grating, which is produced by a grinding action between two parts which ought to move freely upon each other; and (3) atmospheric, which is caused by either an explosion of gas, which ought not to take place, by the emission of gas, or by an exhaust of used gases in such a way as to cause an objectionable noise.

The loss of power in class (1) is accounted for by the fact that any knock or impact must be caused by a greater pressure being put on the objects which knock than is requisite to bring them into their proper position, and the knock is what we may term the taking up of extra power, which is, of course, lost.

In grating noises (2) there is a distinct indication of loss of power, as when the grinding takes place this means friction, and the power is thus lost and dissipated in the form of heat.

Similarly, in what we may term atmospheric noises (3), if these are of the explosive kind, it is evident that some gas is being wrongly exploded which ought to be exploded inside the cylinder and doing useful work. If the noise takes the form of a hiss or something between a hiss and an explosion, it may be taken for granted that the gas is being forced out through some orifice which is so shaped as to greatly retard its rejection, which means that power is being lost in forcing it out.

It is of the greatest importance to the user of a motor car that he should be able to differentiate between these three kinds of noises, and one who has been accustomed to any kind of machinery, even though it be of a noisy description, is able, immediately any unusual noise takes place, to class it under any one of the three heads we have mentioned, which at once narrows down the field of his investigation as to its cause.

Taking the different causes of noise in the order in which we have classified them, knock can almost always be attributed to some bearing or journal having become loose or worn, and is fully dealt with under "Knock" in the preceding pages.

In the case of cams or rods operating the valves, these may work well for a time until their surfaces become slightly worn or their ends hammered down. This will result not only in the valves closing rather quicker and with a sharper impact, but also, on the rise of the cam, the space caused by the wear will have to be taken up, and the plunger will have to travel a greater distance before it comes into contact with the valve stem. The remedy is the readjustment of the valve plungers. (See "Valves.")

Under the class of grating noises we have a source of considerable loss of power, owing to the fact that an abnormal amount of friction must be taking place before it is heard. Whenever this grinding noise is heard, it is safe to assume that something has got hot and that lubrication is wanted. It is most frequently to be met with in the gears, either the

change speed or the differential, and usually denotes lack of lubrication. Sometimes in the case of gears which have become very much worn, the grating sound is commingled with a distinct knocking or vibration as the teeth come into engagement with each other and have to take up the backlash caused by the wear between their engaging faces.

Atmospheric noises are generally caused by the exhaust. In many well-designed cars an exhaust muffler is put on which is efficient so far as its function of silencing goes, but, like every other part of the car, it is necessary that it should have careful attention, otherwise conditions will arise which prevent its performing its duties properly. Thus a considerable accumulation of carbon either inside the pipes leading to the muffler or inside the muffler itself may so restrict the passages that the exhaust has considerable difficulty in escaping, and can only do so with a hissing noise. Whenever this noise becomes greater than that usually experienced from the exhaust, attention should be given to it, because not only does the carbon deposit restrict the passages in which it is deposited, but it acts as a most efficient retainer of the heat, and prevents the exhaust gases being cooled as they ought to be during their passage through the muffler. Thus they not only have a restricted area through which to pass, but their volume is kept higher than it should be, both these effects tending to multiply each other as regards the cause of the hissing noise. The cause is generally to be found in too much lubrication of the engine, or the use of an improper mixture, and the remedy is to thoroughly clean out all the exhaust pipes and the chambers of the muffler, to drive the car so as to use the best mixture, and to supply it with lubricant in exactly the right quantity, without any excess.

Explosive noises are generally caused by an ignition of gas either in the carbureter passages or in the exhaust box. This, of course, is an indication that explosive gases which ought to be used in the cylinder are escaping. In the case of explosion, or popping, in the carbureter the causes of the trouble and the remedies are fully described under "Carbura-

tion Troubles" and "Blow Back."

Explosions in the muffler are mostly caused by misfires, usually due to some defect in the ignition system. When this takes place the gas charge, which should be fired in the cylinder, is forced out into the exhaust passages, and is naturally ignited by the red hot exhaust which follows on the next proper power stroke. The remedy is, of course, to see that the ignition is so regulated that it fires after each compression stroke. (See "Muffler Troubles" in the preceding pages.)

Perhaps the most objectionable form of noise is that caused by a general looseness all round; parts shaking about which ought to be rigidly attached to some portion of the mechanism. This denotes a general carelessness in attention to the machine, and can only be obviated by frequent periodical inspection, and the tightening up of all parts likely to become loose, from the very first time the car is used on the road. If a car has been habitually neglected in this respect, it becomes almost impossible to remedy this general noisiness, and many cars which should run practically silently for years will if badly attended to become in a few months' time, veritable rattle boxes. A distinct knock will be set up if heavy parts such as the gear box or crank case become loose on their bearers through the slacking back of the nuts. We have known this happen in the case of a gear box through one nut slackening back and causing a knock which was very difficult to locate. It is necessary, therefore, to insure that all parts are properly tightened up.

NUTS AND BOLTS.

Symptoms: Parts become loose, rattle, or even shake off altogether.—Difficulty in removing nuts or bolts.

Causes: Improperly tightening.—Neglect to use lock nuts or split pins.—Neglect to grease or otherwise lubricate nut or bolt before assembling.

These require careful attention. In a motor car the vibra-

tion is so considerable that a nut, even though secured by a lock nut, is not sufficient. It should be secured in addition by means of a split pin, and occasional examination should be made to see that the pins are in place. We have seen serious damage caused through neglect in this direction. If there is more than one bolt holding two portions together, each should be screwed up equally, a little at a time, and it should be borne in mind that with a long heavy spanner immense leverage can be applied, and consequently nuts and bolts should not be over-tightened. One should seek to strike the happy mean. It will be found that a nut or a bolt can be tightened up much more effectually if the head of the bolt is given a sharp short blow with a hammer while pressure is being exerted on the spanner gripping the nut.

Spare nuts and bolts should always be carried as part of the kit, in case of loss or breakage.

Sometimes an over-tightened nut, bolt, or spark plug is very difficult to remove, especially if it has become rusted into position. The use of undue force may cause serious damage. If the nut or bolt will not yield to ordinary pressure, treat plentifully with kerosene, leaving ample time for it to penetrate to the seat of the trouble. If this is not successful, try the effect of heat. If the refractory member is in contact with the cylinder or combustion head, run the engine for a few minutes. In other cases a blow-lamp may be used judiciously. If no blow-lamp is available, a little cotton wool or waste wrapped loosely around the joint, soaked with gasolene, and lighted, will raise the temperature sufficiently to ease the joint.

Prevention in all these cases is better than cure. A paste of graphite and gasolene mixed, applied to the screw does not affect the bite of the screw, and at the same time it prevents undue adhesion.

When commencing to screw a nut, if it is not started true on the end of the bolt it is likely to get on the skew, or otherwise cross-threaded. For this reason the nut should first be applied with the fingers. If there is considerable re-

sistance, it is an indication that the nut has not been placed on true, and, if forced, the threads of either nut or screw will be stripped. Sometimes the first thread of a bolt gets burred through being struck on the top with a metal instrument, instead of placing a block of wood between, or for some other reason. Before applying the nut the burr must be filed off and the thread groove carefully cleaned with the edge of a half-round or three-square file. If the nut is unduly forced against the shoulder end of the thread, the bolt may be twisted off.

It is essential that the spanner should be used with discretion. If it is of the adjustable variety, the operator should be careful to adjust the jaws so as to grip closely, and also to push them right home on the nut or bolt; otherwise the edges of the hexagon head of the nut or bolt will certainly be damaged through the spanner slipping. It is a great mistake to over-tighten nuts or bolts; it very often results in a thread being stripped, and sometimes great difficulty is experienced in removing the nut or bolt after it has remained in position for any considerable period.

OVERHEATING.

Symptoms: Smell of burning.—Slight smoke.—Knock.—Engine gradually slows and finally stops.—Sometimes engine will fire after current is switched off.—Piston seizes (rarely).—Water steams.

Causes: Defect in water circulation.—Choked or ineffective radiator.—Choked water pipes.—Pump out of order.—Escape of water.—Air lock.—Continuous hill climbing at a slow pace with a tail wind.—Insufficient lubrication.—Unsuitable oil.—Running engine too fast.—Escape of compression into base chamber through defective piston rings or worn cylinders.—Faulty carburation.—Running continuously with one cylinder misfiring.—Ignition retarded too much.—Insufficient lift of exhaust valve.—Slipping clutch.

Most of the causes are fully dealt with under other headings herein, such as Water Circulation, Lubrication, Compression, Carburation, and Timing. A fruitful cause of overheating is running with the ignition retarded and the throttle fully open. Racing the engine will have the same effect, or

allowing it to labor on hills (see Driving), or using too rich a mixture. Faulty valve timing may also cause trouble, especially if the exhaust valve has an insufficient lift due to the distance between the tappet rod and the valve stem being too great. This has the effect of causing the valve to open too late and close too early, thus putting a back pressure on the engine, and retaining some of the burnt charge in the combustion chamber. An escape of compression into the base chamber can be diagnosed by feeling the base chamber, which, under such circumstances, will become unduly hot. If the clutch is slipping, the engine will run fast, while the car will travel slowly. To diagnose this trouble see if the clutch is hot. A little litharge will often fix a leather clutch. If the fan belt slips, overheating may result. In most modern cars there is adequate adjustment provided for the fan belt. Where a twisted raw hide belt is fitted, its tension may be increased by undoing the coupling or hook and twisting the belt up again for a few turns.

In case of serious overheating the engine should preferably be stopped and allowed to cool. The radiator may, however, be replenished with cold water, provided it is filled in very gradually, with the engine running slowly meantime.

To remedy a seized piston due to excessive overheating kerosene is as good as anything short of a new piston.

Overheating may be due to wrong carburation giving too rich a mixture, to ignition that is timed to occur too late, or to failure of the water circulation due to leakage, pump derangements, or air locks, all of which are simple to discover and usually not difficult to correct, even for the novice.

Very often overheating is caused by failing to change down early enough on an ascent, resulting in the engine laboring. Under such circumstances the cooling is inefficient because both pump and fan are working at a slow speed, while the volume of mixture is at its maximum. By changing down and running the engine something over the normal, the throttle need not be fully open, and both pump and fan will be running fast. This will prevent overheating.

In the case of cars using a fan on the periphery of the engine flywheel, or in which the arms of the flywheel form the vanes of a fan, it is essential that the whole of the space forward of the engine and surrounding it should be inclosed by a practically air-tight bonnet and under apron. If any of the apertures used for getting at parts of the engine are left open, the air-drawing effect of the flywheel fan will be nullified, and on hills, where the car is traveling slowly and the engine rotating at great speed, overheating is likely to ensue, especially if there is a tail wind blowing.

PISTON TROUBLES.

Symptoms: Loss of compression.—Gradual weakening of engine.—Knock.—Seizing of piston.—Preignition from carbon deposit.

Causes: Rings stuck with gummy deposit.—Rings worn or broken.—Slots coinciding with each other.—Rings bad fit.—Defective or excessive lubrication.—Overheating.

In a modern car little trouble will be experienced with the piston, which is made a proper fit to the cylinder. The wearing oval of the cylinder is a bogey which has been by this time sufficiently dispelled. It is only after use for many years that a cylinder properly designed, and of the right material, will wear oval. The greatest trouble which may be experienced from the piston is loss of compression due to the gases passing between the outside surface of the piston and the walls of the cylinder into the crank chamber. This is due in practically every case to defects in the piston rings, and loss in this direction will be indicated by brown surfaces on the faces of the piston rings. Sometimes the piston rings gradually work round so that the slots in them will coincide, or nearly coincide with each other. In such cases considerable loss of power will result. This is not due to the piston being a bad fit, but solely to the aperture which is thus made for the gases to flow by the piston. On taking off a cylinder to examine the piston it is advisable not to turn it in the slightest degree, so that when it is lifted off the piston the position of the slots in the piston rings can be determined. The slots should be equi-

distant from each other, so that if there are three rings they should be at one-third of a circle away from each other, and if there are four rings the slots should be at a quarter of a circle away from each other.

In the case of pistons fitted with three rings it is usual to place the slot in the middle ring at the contrary angle to the slots in the top and bottom rings. In modern practice the rings are pegged so that they cannot rotate.

Leakage of compression past the piston also includes leakage of the expanded gas charge and therefore heating up of the base chamber. If the base chamber becomes unduly hot and it is ascertained that the lubrication is in perfect order, it may be taken for granted that there is loss of compression past the piston and the rings may require renewing. Failure to make a proper joint between the piston and the walls of the cylinder may be due to the use of an inferior and improper oil which gums and prevents the piston rings expanding properly in the slots in the piston. The remedy for this is to take out the piston, take off the rings, and thoroughly clean and scrape the slots in which the piston rings move, both at their sides and at the bottom. A slight slackness up and down of the piston ring in its slot is of no great consequence so long as the surfaces are clean. When a ring is broken it is absolutely necessary that it should be replaced with a new ring.

A careful examination of the wearing faces of the rings will determine if they are holding correctly against compression and expansion. If there is any leakage, it will be shown, and its place indicated, as already mentioned, by brown places on the rings. This may mean that the rings have become weak and that new ones are needed. If the surfaces of all the rings are quite bright and polished, with no brown or discolored places, it may be taken for granted that they are in good order, and quite tight; and all the attention required will be a good cleaning and scraping of all carbon deposit away from the rings and the grooves.

No difficulty will be experienced in taking the piston with its rings out of the cylinder, but considerable difficulty may

be experienced in getting the piston with the rings in proper position back into the cylinder.

Generally there is a wide taper on the mouth of the cylinder which automatically closes the rings in their grooves as the piston is pushed up.

When fitting new piston rings it is necessary first to see that they fit properly in the grooves in the piston. There should be just the slightest amount of shake sideways. It should also be ascertained that they will fit up inside the cylinder when compressed. For this purpose it is best to try to fit them first inside the cylinder. If they are too long circumferentially, it will be necessary to file their ends slightly, so that when in the bore of the cylinder they will come together fairly and squarely. This having been determined, they can next be fitted to the piston. If they are so wide that they fit tightly in the grooves in the piston they will have to be reduced in width, which can be done by rubbing them on a flat board upon which a piece of emery cloth has been tacked. They should first be tried all round in the groove of the piston.

In fitting them on the piston, it is advisable to use slips of very thin metal, such as tin or zinc, to prevent the rings intended for the lower slots slipping into the upper ones. Three strips will be sufficient, and the rings should be sprung over them and pushed down, the first ring into the bottom slot, the second ring into the middle slot, while the last ring can be fitted in the top slot without the aid of the strips. There is no difficulty about this operation, but it requires just ordinary care not to expand the piston rings to such an extent that they snap, for being made of fine cast iron, they are naturally very brittle and cannot be expected to expand more than sufficiently to put them over the piston and into their grooves.

Sometimes piston rings break. This is generally due to lack of lubrication and the seizing or partial seizing of the piston in the cylinder. In such cases they will require renewal, and it is then advisable to put the best of the already worn piston rings in the top groove, as a new piston ring is

not absolutely gastight until it has been running for some considerable distance.

In addition to the repairs or adjustments which may be necessary to the rings there is the important question of the piston pin and its bearing. If the piston pin becomes loose in the bosses of the piston it may work out endways, and, being hardened, it may score the sides of the walls and even mill grooves in the sides sufficient to considerably reduce the power of the engine through loss of compression.

Knock in the piston may also be set up by the piston pin becoming loose, and, similarly, knock may be set up by the bearing in the little end of the connecting rod becoming too large for the piston pin.

There are generally screwed pins, sometimes tapered, which hold the piston pin in position. It is essential to see that these are screwed up tight and that they are locked by means of a split ring or a split pin or any other locking device which will prevent them rotating. If through faulty lubrication or neglect of lubrication or failure in the circulating system the piston should seize in the cylinder, it will be necessary to inject kerosene and to oscillate the crank shaft so as to gradually release the piston, after which a thorough cleansing will suffice to set things right, if no serious scoring has developed through piston ring breakage or otherwise.

The head of the piston will periodically require cleaning due to carbon deposits. This trouble will be accentuated if the engine is badly treated, as through over-lubrication and overheating, or from running with too rich mixture or retarded ignition. In some modern motor cars, the center of the piston does not coincide with the center of the crank pin. Also sometimes the center line of the connecting rod is nearer one side or the other of the little end bearing and nearer one side or the other of the crank pin bearing. It becomes necessary, therefore, to determine before replacing the piston that the right side is to the fore or back of the engine as the case may be, otherwise the big end of the connecting rod when

being fitted to the crank pin will not coincide with it. It is well in such cases before taking the piston out of the cylinder to make a notch with a file on the edge or mouth of the piston and on the mouth of the cylinder.

POWER, LOSS OF.

Symptoms: Sluggish running.

Causes: Ignition.—Short circuits.—Battery exhausted.—Coil defective.—Timing wrong.—Sparking plug defective.—Ends of plug wires too far apart.—Contact-maker disk grooved or worn.—Contact blades worn, bent, or not making proper contact.—Fiber disk worn.

Carburation.—Dirt or water in carbureter.—Float punctured.—Float too light, or lop-sided.—Supply pipe choked or of insufficient bore.—Jet choked, frozen, or of insufficient bore.—Filters choked.—Stale gasoline.—Valve spindle bent or worn.—Leak of pressure; pressure valve not set properly, or sticking (in the case of pressure feed).—Vacuum in supply tank through closing of air inlet (in case of gravity feed).

Valves.—Dirty or pitted.—Springs too weak.—Timing wrong.—Valve stem bent.—Valve stem too long or too short.—Dirt under seating.

Bad Circulation.—Air lock.—Steam bound.—Pump out of order.

Bad Compression.—Excessive lubrication.—Want of lubrication.—Overheating.—Piston rings.—Clutch slipping.—Muffler choked through over-lubrication.

When the symptoms are clearly defined it is, as a rule, easy to diagnose a trouble, but when the car simply loses power and begins to run sluggishly it is often very difficult to locate the cause. Anything which interferes with the efficiency of the engine or transmission system may cause the engine to lose power or the car to run badly. If there is a sudden loss of power, accompanied by a smell and a tendency to knock, the trouble may be due to overheating. See Overheating, Piston Troubles, etc., in preceding pages.

Short circuit or other ignition failures are a fruitful source of feeble running, which also may be due to unduly rich or lean mixture.

If it is the timing that is at fault, uneven, jerky and

harsh running will accompany the loss of power. Wear in the valve mechanism, springs, etc., is dealt with under Valves. Perhaps the most insidious cause is a choked muffler, causing back pressure. (See Muffler.) The various symptoms and causes are given very fully in Table I., and are fully described under separate headings in Repairs and Adjustments.

PRESSURE, LOSS OF.

Symptoms: Failure in feed.

Causes: Failure in valve.—Filling cap loose.—Leakage in pipes.

The pressure is exerted on the surface of the gasolene and oil by the exhaust gas of the engine. In order to regulate this pressure, a double mushroom-headed valve, in the nature of a back pressure and safety valve combined, is fitted close to the exhaust pipe, where the supply is being taken from. Any leakage will prevent sufficient pressure being maintained, and may arise from—

Filling cap of gasolene tank being loose, or leather washer defective.

Filling cap of oil tank being loose or washer defective.

Leaking conducting pipes or couplings.

Dirt under either of the valve heads will also affect the pressure. A little kerosene or gasolene should be dropped into the valve, and the bottom of the nut should be turned with the fingers to allow the liquid to reach the valve seating, and so grind out any dirt which may rest between the valve and its seating.

Sometimes the valve heads require grinding to make a good joint with their seatings, or the springs holding the valves in position may be defective and require renewing, or the valve may be wrongly set. The operator should experiment with the valve until the gauge shows a pressure of from two to four pounds per square inch, according to the make of the car.

When filling the gasolene tank see that the pressure cock is open. Always let off the pressure after stopping the engine. In case of a "flare up" the pressure cock must be opened at

all cost, or the gasolene will continue to feed the flames. The same careful attention should be given in the case of pressure fed lubrication, especially to the relief valve. (See Leaks.)

RUSTING UP OF JOINTS OR MOVING PARTS.

Symptoms: Binding of working parts.—Flaking off of paint, enamel, or plating.

Causes: Exposure to wet or atmosphere.—Neglect of lubrication and proper cleaning.

Ordinary rust, if not permitted to penetrate deeply, may be readily removed by brushing the parts with kerosene, in which a little lime has been slaked. When the surface has been cleaned the joints or knuckles should be well oiled. These instructions particularly concern such movements as the brake rods, the leaves of the springs, and any rod having as a means of adjustment a screw and a nut. If by chance any such should become "set," that is, impossible to disturb without risk of straining or breakage, a blow-lamp—which will be found a useful adjunct to the repair outfit—may be used to heat the part. The application of a little kerosene will then suffice to clean the scale, and the nut may be readily slacked back.

Unless kept dry and oiled, rust will penetrate through the paint or enamel or plating of the metal parts of the car. The remedy is to brighten with emery cloth and re-paint.

SPRINGS.

Symptoms: Broken leaf.—Car becomes lop-sided.—Creak or squeak in spring.

Causes: Sudden shock.—Rough roads.—Overloading.—Want of lubrication.

A fracture of the springs is not an uncommon occurrence, and is generally due to fast traveling over rough roads, jumping culverts, or overloading the car.

Roadside temporary repairs to springs may be made as follows: The tourist should carry with him a short length of spring leaf, with suitable clamps to secure it in position should a breakage occur. Failing this, however, there are

other methods of making a temporary repair, sufficiently substantial to enable the car to continue its journey.

The following is a very interesting example illustrated in Fig. 1. The main leaf A of one of the front springs broke at E, about six inches from the hanger. This left only the under leaf F, which was very thin, connected to the hanger. The shock of the sudden breakage caused this under leaf to bend close up to the hanger at a comparatively sharp angle, and, as a result, the short length of the upper leaf stuck upwards at an angle of 45 degrees. The problem was, first, to get them together again, and, secondly, the best way to clamp them so as to insure that the spring would not break away altogether from the hanger.

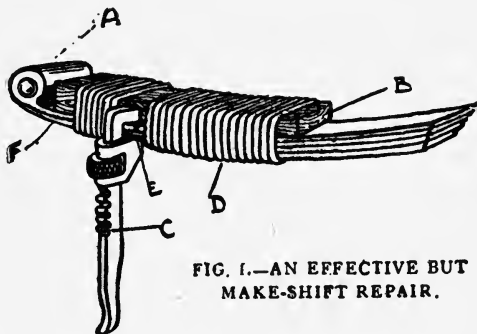

FIG. 1.—AN EFFECTIVE BUT MAKE-SHIFT REPAIR.

The car was first jacked up by the end of the hanger. This relieved the strain on the under leaf F, but made little alteration in the position of the broken length of the top leaf. With the object of forcing the latter downward, so that the broken edges would come together, the jaws of a small, but strong, spanner C were opened to a width of about half an inch, slipped over both leaves, just outside the junction with the hanger, and then, with the aid of a cold chisel and hammer, forced back along the leaves, by which means the two edges were almost brought together. From a neighboring cottage a block of wood B about eighteen inches long was procured. Having shaped it to fit snugly into the angle of the hanger, the next difficulty was to cut a receptacle for the head of the

spanner, so that the block might rest dead true on top of the broken leaf. This had to be laboriously effected with a small pen-knife. No copper wire was available, but the driver procured some iron wire from the cottage, and also a short length of rope. The wire was first laboriously wound taut round the block of wood and spring, and then the length of rope D was added, the end being made fast to the end of the spring hanger. Water was then poured on the rope, which contracted to such an extent that the broken leaf, the bent leaf beneath it, and the block were pressed together until the edges of the fracture came true and square, and the spanner, which had previously been immovably fixed where it was wedged, dropped off on to the ground. This repair proved absolutely effectual, notwithstanding the very crude and inefficient material which was available.

The breakage of a top leaf of a spring is very unusual, and, needless to say, is the most difficult to deal with. It is generally one of the other leaves which collapses, and here the operation is much simpler.

In the accompanying sketches are shown alternative methods of making temporary spring repairs on the road. Fig. 1 shows the temporary repair just described.

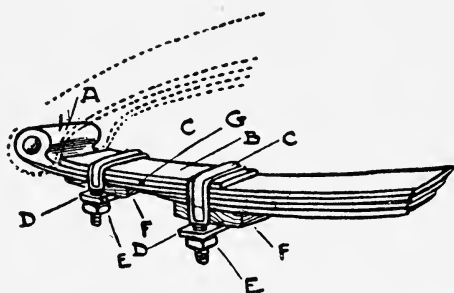

FIG. 2.—THE BEST METHOD.

When motoring in a district where the roads are very humpy, and especially where culverts have to be negotiated, it is well to be forearmed against spring breakages. In Fig. 2 is shown a very good spring repair job effected with

a few spare parts, which can be easily carried in the tool kit. These consist of a couple of spring straps with nuts, as shown at C in Fig. 3, and a couple of plates as at D, with two holes in them to correspond with the screwed ends of the straps C. In addition, there should be provided two wooden blocks of the width of the springs, and an odd length of stiff spring plate about a foot or fifteen inches long. These straps and plates can be had from any hardware dealer for a trifle, and should be wide enough to take the widest spring on the car.

The repair is effected as shown in Fig. 2. The break is

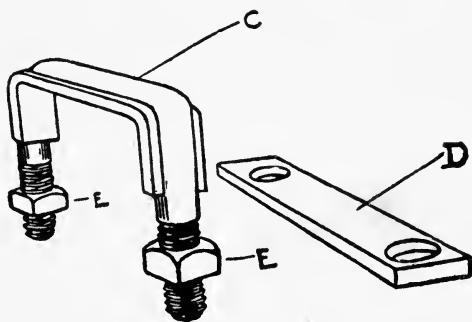

FIG. 3.—STRAPS WITH NUT AND PLATE.

supposed to be in the top plate as at G, and the odd length of spring plate forming the splint is shown at B. The straps C, C, with their plates D, D, are firmly bolted up with the wooden packing blocks F, F, in position as shown. The beauty of this method of bolting up a spring is that it insures the spring plate and leaves being drawn down into their proper and normal positions, and a good repair is effected which will allow of the car being used for a considerable time until a replacement can be obtained.

Where a motorist has not provided himself with the straps shown, a really good repair can be made as shown in Fig. 4. Here four short lengths of iron bar A, A, A, A, about one inch wide by a quarter inch thick, are drilled with a hole near each end, and four bolts and nuts D, D, D, D, clamp them tight—two on the top of and two underneath the spring. A

plate of iron B is used as a splint on the top of the spring plate, and wooden blocks C, C are arranged underneath. The materials to make such a repair can be readily obtained at any country blacksmith's or hardware store.

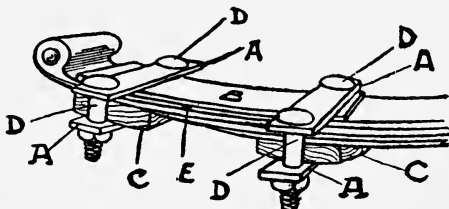

FIG. 4.—ANOTHER SYSTEM.

As there is a considerable amount of wear between the laminated plates of springs, they should be kept well lubricated between the laminations, a good graphite grease being the best of this purpose.

STARTING TROUBLES.

Symptoms: Engine refuses to start when switched on and starting handle turned.

Causes: Ignition faulty.—Carbureter frozen.—Loss or breakage of starting gear.

Starting troubles are frequently due to the ignition. The batteries may be run down or the spark plugs may be foul, due to the engine having been stopped by switching off the ignition, and oil having thus remained on the sparking points. It would be wise, therefore, always to stop by throttling off rather than by switching off.

In coil and battery ignition, the trembler in the coil may be at fault, and we have known a refractory engine started by the help of a friend who kept tapping the trembler blades with a pencil while the starting handle was being turned. This, of course, indicates that the tremblers require readjusting, which should at once be carried out, as described under Ignition, in the preceding pages.

The rapidity with which the engine can be turned by hand

is an important factor as regards the ease of starting, and to get the best results in this respect, the motorist should squirt about a teaspoonful of kerosene through each compression cock at the conclusion of the day's work while the engine is still hot, and should then give the starting handle a few turns. This will clean the piston rings and the cylinder, and thus prevent the oil clogging, and so making it difficult to turn the starting handle when the car is to be restarted.

Needless to say, the carbureter should be flooded before starting, and only by experience will one learn to what extent this should be carried out. In the case of some engines, excessive flooding renders starting difficult. If after flooding the engine is still refractory, gasolene should be injected from the outside to insure an initial explosion. The usual system is to squirt it through the compression cocks. This is not always effective, however, and where an extra air inlet is fitted between the carbureter proper and the inlet valves, it would be better to squirt the gasolene in here, pushing down the slide valve where such is used, so as to insure the spirit reaching the inlet pipe. Where no compression cocks are fitted, or where the extra air inlet is not conveniently situated, a small hole should be drilled in the inlet pipe close to its union with the cylinder, and this should normally be kept closed by means of a spring oil hole cover, such as is used in cycle pedals, or by a small thumbscrew. The vapor from gasolene which has been squirted in here will at once enter the inlet ports when the engine is turned by hand, and so provide a good explosive mixture.

Small spring oil cans for gasolene and for kerosene should be fixed inside the dashboard by means of neat clips, so as to be always available. If trouble is still experienced, the extra air inlet should be temporarily closed. A pocket handkerchief or other cloth held over it will do the needful.

In most cars there is a special position for both the ignition lever and the carburation lever which is best for easy starting, and this will be found by experience. It is sometimes advisable, also, to slightly depress the accelerator pedal

while actuating the starting handle. If a helper is not available to hold it down, a stone or other weight will suffice.

If stoppage of the engine occurs when ascending a hill, put in the reverse gear, allow the car to run backward, and gently let in the clutch, the throttle being open, and the ignition switch turned on. On the engine starting, the clutch should be taken out and the brakes put on to bring the car to a standstill, when the ascent can be continued. When adopting this method one should be careful not to let the car run backward too fast, and also to see that the brakes are in sound working order, and efficient backward as well as forward. The ignition should be nearly fully retarded.

Four and six cylindered motors can often be easily started by giving a few quick turns to the engine with the ignition switched off and the throttle fully open. This will charge the cylinders. Then operate the switch quickly, and the engine will generally start. This can only be done when a trembler coil is used, and the compression and valves are in good order. It is impossible in the case of an engine fitted with low tension magneto, while there are only one or two cases of high-tension magneto where it is effective.

Starting in winter time is often difficult owing to the cold, which may sometimes cause the formation of ice in the carbureter due to the rapid evaporation. In such cases heating of the carbureter by means of a hot iron held against it or by bandages of flannel or cleaning cloths around it kept hot with boiling water, may enable the car to be started easily.

To start a motor when the starting mechanism is broken or the starting handle lost, put the second or third speed gear into operation, and with the clutch out, allow the car to run downhill until it has attained a pace of 9 or 10 miles an hour, and then let the clutch in gradually. Or if no hill is available, jack up one wheel of the car, block the other wheels with stones, etc., put in the top speed, and start the engine by pulling round the free wheel. When the engine is started, put the gear in the neutral position, let down the wheel when it has stopped rotating, and proceed.

If two or three helpers are available, the engine can be started by pushing the car, and, while it is in motion, letting the clutch in gradually.

Self-starters using compressed air, compressed by the motor and stored in a cylinder, and others using a high powered spring have been introduced, and while they can hardly be considered essential in modern cars, of course they are most convenient.

For the procedure in starting up an engine and the necessary previous adjustments with any given car, the best source of authoritative information is the maker's instruction book, every car having its own peculiarities. For ignition, carbureter, and compression troubles which prevent starting, look under the headings referring to these subjects.

THE STEERING GEAR.

Symptoms: Steering stiff or jerky.—Driver loses control.—Considerable backlash between steering wheel and road wheels.

Causes: Unpinned bolt drops out.—Ball of ball joint comes adrift through wear or want of adjustment.—A link or a steering arm breaks.—Bent steering link.—Want of lubrication.—Backlash due to wear in worm and sector.—Wear in joints of actuating levers, in the front axle jaws or in the swivel pins.—Worn or loose bearings.—Wheels out of alignment.

In one sense the steering gear is the most vital part of the car, for a failure, if traveling at any speed, is very likely to result in a serious accident. The nuts and bolts securing the various joints should be properly pinned and inspected regularly to see that the pins are in position. In the case of ball joints these should also be subject to frequent inspection, and should be renewed if the ball shows signs of flattening. Cases have occurred when the ball jolted out of the joint socket on account of having worn flat on two sides, and within the fraction of a second the car was off the road. It is well to have all joints covered with leather, carefully wired in position, and filled with vaseline or grease.

Our illustrations show a form of joint covering which not only protects the joint from mud and dust, but prevents the

driver from losing control should the connection fail. Any saddler can produce these covers, which should be made of the best soft leather. Such leather as is used for shoe uppers is very suitable. The shape will vary with different kinds of steering gear, but a paper or cloth pattern is easily made, from which the saddler can cut the actual leather covers. The long

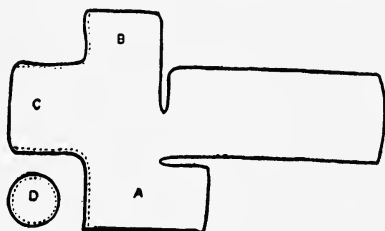

Fig. 1.—A is stitched to B along the dotted lines, and a circular piece, D, is inserted at the end C, and sewn up to close it.

ends should be amply wide and long, so as to lap over each other completely. They may be best secured to the arms and links by a couple of water-pipe clips to each link end and each arm or lever end. The first illustration shows approximately the shape to which the leather should be cut, but this will vary with different steering arrangements. The second shows the end closed over and saddler-sewn, with a circular



Fig. 2.—Showing cover when stitched and adjusted to arm and link, but without the holding clips.

piece sewn in the end, and the way in which the flaps are drawn around the links and rods and overlap each other.

If properly fitted, these covers will hold the steering connections together well enough to enable the driver to pull up before the car actually gets out of control. They also protect the joints from dirt and prevent wear.

A good idea is given by a motorist who advises the use

of a spring between the link and the arm or the link and some part of the chassis frame, attached by means of clips, the spring being in tension and normally keeping the ball in the socket, even though the ball or the socket wears to such an extent as to otherwise let the joint apart. Such springs would in no way interfere with the easy steering of the car.

Frequent lubrication is essential, or the parts will work stiffly and wear rapidly. After a period a certain amount of backlash will be found in the steering wheel and link mechanism, necessitating a considerable movement of the wheel before the front road wheels respond, and also causing excessive wear on the front tires, due to the front wheels not running absolutely parallel to each other. The causes and remedies are as follows:

1. The wear between the steering stem worm and the sector, or the sliding nut and worm, as the case may be, in which it engages. This is very difficult to remedy, but sometimes the movement can be taken up by easing the sides of the case and so bringing the two halves closer together. The screw and rack-and-pinion types can generally be adjusted by means of the lock nuts at the end of the steering column.

2. Wear in ball joints or plain pins connecting the actuating rods and levers will also cause backlash. To locate the source of the trouble, jack up the front wheels, and, getting someone to hold the steering wheel firm, rock one of the road wheels from side to side. This will show where the movement is. If it is a ball joint that is at fault, adjustment of the joint cap may put it right unless the ball is worn, in which case it must be renewed. Should, however, the movement be due to wear in plain pins, they must be renewed and made a good fit for the holes. Perhaps the holes may have worn oval. In this case they must be reamed out, and new pins made to fit them. If incased in a leather fitting, filled with grease, as we have described, little wear may be anticipated.

3. Play in the front axle jaws, or swivel pins is another cause of backlash. This can be diagnosed by rocking the

car sideways when the wheels are on the ground. If the play is very perceptible the worn parts will have to be renewed. In the case of such cars as have ball swivel steering heads there is always adjustment provided, and wear can be easily taken up. If the wheels when freed from the steering links swing round with a jerky motion the ball race is pitted or one or more balls are probably broken. In the case of balls broken these should be replaced. If one or other of the ball races are damaged, they should, of course, be replaced.

4. Worn or loose wheel bearings. Jack up the wheels, and, gripping with both hands, rock them. In the case of ball-bearings, if there is side shake, examine first for wear in the cones or ball races, or for broken balls. If there is no defect of this kind, adjustment is probably all that is needed. When screwing in the cones for this purpose be careful not to over-tighten them, or balls will break. The wheel should revolve smoothly without any sign of stiffness, but there should be no perceptible side movement when it is rocked by hand. For more detailed instructions, see Bearings. Also be sure to lock the cones with the locking devices provided. In the case of excessive wear in a plain bearing the hub will need rebushing.

Sometimes the distance rod between the steering arms may get bent through meeting with some obstruction, thus putting the front wheels out of alignment. This will not only affect the steering, but will grind the rubber off the tread of the tires through the dragging action set up. The link must be carefully straightened by bending.

The same cause may bend the steering arms. In this case the link should be detached and the arms bent back as nearly as possible into their old position, a spanner or block of wood being wedged between the arm and the wheel hub as a fulcrum. It is a workshop job to get them absolutely true, but as a rule the steering link is adjustable as to length, and by careful manipulation the steering wheels can be got into alignment and the car used safely until it is convenient to get the arms put right in a properly equipped workshop.

The best system of checking the alignment of the wheels is to measure with a tape their lateral spacing, as explained under "Wheels, Road."

STOPPAGE OF ENGINE.

Symptoms: Engine stops for no apparent reason.

Causes: Ignition wrong.—Gasolene fails through stoppage or otherwise.—Laboring too long on hill before changing.

When an engine stops for no apparent cause the trouble may generally be looked for in the ignition. If it stops suddenly, see to coil and connections to battery, storage battery or igniters (in the case of low tension magneto). If the stoppage is gradual it may be caused by a short in one igniter (in the case of low tension magneto ignition) or by failure in the carbureter, shortage of gasolene, lack of gasolene, or gasolene pipes choked up, or passages to carbureter or jet choked.

A breakage of any part of the engine, such as is caused by bad treatment or lack of lubrication, will, of course, cause it to stop.

The experienced motorist will know by the manner in which the engine stops where first to look for the fault.

Stoppage of the engine on a hill due to partially closing the throttle to change speed and then letting in the clutch with the full load on and the engine running slowly may occasionally occur. The driver who has once experienced this will know how to prevent it in future, and, of course, no repair or adjustment is required. For causes which result in engine stoppages the reader is referred to the articles on Ignition; Carburetion, Lubrication, Overheating, Compression, Timing, etc.

TIMING—INCORRECT.

Symptoms: Knock.—Loss of power.—Overheating.—Irregular firing.—Harsh running.

Causes: Ignition or valve timing faulty.

If the timing is not correct both as regards ignition and

valves, the engine cannot give its full power or run sweetly, and in extreme cases injury will be caused to the bearings due to the constant hammering. Above all, it is essential that the firing in the various cylinders should exactly synchronize. In the case of low tension magneto ignition the greatest nicety of adjustment is necessary. This subject is fully dealt with both as regards ignition and valve timing, in the chapter on Overhauling.

TIRES.

Symptoms: Puncture of air tube.—Boil in cover.—Burst.—Clean longitudinal cut in rubber separating it from canvas cover.

Causes: Nails.—Pieces of metal.—Sharp stones.—Air tube nipped under bead of head of security bolt or of valve.—Tire bolts defective or bent.—Air tube frayed by faulty patch on cover.—Gradual failure of fabric due to split formed inside by flexion, or moisture penetrating neglected cut in rubber.—Neglect to repair boil in time.—Tire bolts not tightened.—Fabric completely worn out.—Excessive flexion due to tires not being pumped hard enough, or to faulty construction causing uneven strain on strands of fabric in one particular spot.

The variation in the behavior of the same make of tire under identical cars, but in the hands of different drivers, is very great, and points unmistakably to the fact that the majority of tire troubles are due to the drivers themselves, both as regards the splitting of the fabric and wear to the rubber tread through attrition and cuts.

1. **Prevention**—To begin with, proper inflation is of vital importance. If the tire is not pumped hard enough, the flexion and friction will cause rapid wear. Stones also will gash both casing and air tube against the rim. On the other hand, if the tire is pumped board hard, the wear is rapid, and the bumping will prove most uncomfortable for the occupants of the car and tend to shake the vehicle to pieces. According to our experience, the tire should be so pumped that, when the car is fully loaded, the depression, where the tire touches the ground, is just appreciable, but no more. Another test is to catch the side of the wheel with the hand, and pull it backward and forward forcibly. If there is a pro-

nounced lateral roll, it is a pretty clear index that the tire is too soft.

Here are the special instructions issued by the makers of the Michelin tires: "Whether the tire is properly inflated or not is shown by the extent to which it flattens. When the carriage is loaded the tire ought to flatten about $\frac{2}{5}$ ths of an inch, but should never, even on the level streets of a town, be depressed more than $\frac{3}{5}$ ths of an inch." This, however, at the best, is but a rough and ready method of testing the inflation. A good pressure gauge, independent of the pump, is essential. Careful drivers, who drive at a reasonable speed, take corners slowly and use their brakes with moderation, can safely and beneficially inflate their tires to a pressure somewhat less than the minimum recommended in the manufacturers' catalogues.

Few motorists have any idea of the great influence the actual driving has on the wear and tear of tires. Corners should be taken at a reasonable speed, and the brakes should never be jammed on hard, except in the case of an actual emergency. One violently sudden stop may do more injury to a tire than a month's ordinary use.

Rust on the edge of the rim is another fruitful source of trouble, and for this reason care should be taken to clean the wet dirt away after each run. Should rust appear, it would be a wise precaution to take off or push back the cover, or casing, and clean it away. The spot should then be treated with some good air-drying enamel, and the bottom of the rim polished with blacklead or graphite. This latter process facilitates the removal and replacement of the cover. When about to inflate the tire, the operator should first make a stroke or two with the pump before screwing it on the valve, so as to eject the dust which might otherwise get into the valve and cause a leakage. The valve cap should always be kept screwed on to prevent dust entering, except when the tire is being actually inflated. It is of great importance that the fixing bolts should be invariably screwed up tight—by hand only—for if they are not, the cover will move, and damage will be caused to

the edges and to the air tube, or the air tube may blow out between the bead and the rim. In extreme cases the valve may be even torn out; water, too, may get in, and rot the fabric. After putting on a new cover, or repairing a puncture, it will be found that the bolts get comparatively loose within a few miles, and consequently it is well to examine them at intervals, and screw them right home. Another source of trouble is to be found in the canvas covering the bolt head or flange, on which the air tube rests, becoming creased or displaced. This may nip the air tube or set up wearing friction. Bent bolts should be straightened, or if seriously damaged discarded, otherwise the heads may not sit straight inside the tire, and the air tube may get nipped. Cuts in the outer cover, which penetrate to the fabric, will inevitably admit water, and so rot the cover. These should be repaired at once.

Needless to say, puncture is the most frequent source of trouble. This, in a large proportion of cases, is due to the air tube becoming nipped, through the tire having been put on wrongly. Many owners never trust any maker, but make a point of detaching each tire and seeing that the air tube is properly placed before driving a new car. The cause of nipping we will deal with when describing how to replace an air tube. Next to nipping, nails are the most frequent cause of puncture. With unprotected tires nail-catchers are effective. If the tire is smooth on the tread a very simple catch can be improvised out of light curb chains attached to the lower side of the mudguard, so that the loop touches the tire and extracts the nail before it has penetrated any distance.

The protection of tires from damp and sunlight, either when complete or when the cover and air-tube are separate, is of vital importance. If the cover is exposed to damp, tiny mushroom organisms form rapidly, which reduce the fabric to mold, whereas sunlight has a very bad effect on the rubber; consequently spare tires should be kept in a cool, dry atmosphere. When fixed to the car, as in the case of detachable rims or demountable wheels, they should be completely cov-

ered. The floor of the garage should be kept dry and free from oil, and if the car is not in use for a considerable period, it would be well to jack up the wheels. All sand and grit should be removed after every run. If allowed to remain, they accumulate and form little lumps which eventually cut through the canvas. Above all things, the rubber should be kept from contact with grease, which is most deleterious—causing the rubber to lose its elasticity and become rotten. The rims should be carefully dried after a muddy run, and should be kept clean and free from rust.

Tires should be cleansed with a damp sponge or cloth, and on no account should a mixture of kerosene and water, which is sometimes used for cleaning the bodywork, be allowed to reach them. Kerosene has a most damaging effect on rubber.

In the case of metal-studded tires, repairs are difficult, and very often cannot effectively be carried out. The most usual defect is a loss of studs through the violent application of the brakes or starting too suddenly. The hole left in the rubber is apt to let the wet into the fabric, which will prove fatal to the cover in a very short time. In most cases it may be possible to fill up these holes either with the aid of one of the special preparations supplied for filling cuts or with the help of a vulcanizer. It is well worth trying at all events.

2. **Detaching Edge of Casing**—Whether a puncture is due to some penetrating substance or to the troublesome nip, the method of repair is the same in the case of the popular clinched-on type of pneumatic tire. The first operation is to jack up the wheel which carries the punctured tire, having first “chocked off” the other wheels by means of blocks placed before and behind; otherwise the car may move forward or backward and break the jack or injure the rim and tire. The butterfly nuts should be unscrewed from the bolts to the end of the screw, but, as a rule, need not be entirely removed. The bolts should be pushed upwards, with the aid of a tire remover held flat, until they are flush with the felloe. The valve stem also should be cleared of nuts, etc., and pushed upwards, using the tire remover, gripped in both

hands for the purpose. Under no circumstances should the end of the valve stem be struck with any instrument, wooden or otherwise. The cover should then be worked with the hands until the near bead is loosened in the flange or clinch of the rim, and then the end of one of the tire levers should be inserted under the bead—carefully, however, lest the inner tube be nipped. Meanwhile the tire bolts in the immediate neighborhood should be pushed upward until the butterfly nuts touch the felloe. The second and third tire levers should be inserted about 6 or 8 inches further on, but clear of the tire bolts. If the operator is alone, he should get his left knee against the first lever and catch the other two in his right and left hand respectively. Simultaneous pressure on all three will remove a considerable length of the bead out of the rim. If a passenger is present to operate number one lever, his assistance should, of course, be enlisted. The remainder of the casing can then, as a rule, be taken off by a strong pull of the hand inserted under the edge. If not, the use of the tire levers must be continued. One side of the cover being off, the air tube can be wholly withdrawn, on the valve being lifted out of the rim in the manner hereinafter described.

Special dismantling levers of various types are on the market designed to facilitate the removal or replacement of the valve or security (tire) bolts, and the detachment and replacement of the beaded edges of the cover. They are described further on.

3. **Replacing the Casing**—To get the casing bead back into position first replace the air tube in the manner hereinafter described, carefully avoiding twists or distortions, and then slightly inflate the tube so as to prevent its getting nipped under the tire bolt or valve head. Next push the stem of the valve up high into the tire, and carefully getting the edge of the cover, where it has a piece nicked out opposite the stem of the valve, push it down between the head of the valve and the rim with the hands or tire levers, working it gradually into position under the clinch of the rim. For this purpose the hooked end of the tire lever should be slipped over the bead

of the rim and the other end of the lever raised. The flat end of a second tire lever may be used for pushing the beaded edge of the cover home under the edge of the rim. The last little bit is generally the most troublesome, but a few vigorous pushes on the tire lever will force it home. Care must be taken as each bolt is approached to push it up until the butterfly nut is flush with the felloe, so that the edge of the cover is sure to get under the head of the bolt. It is a good plan, then, to knead the tire backward and forward with the hands, so as to make sure that everything is in position. Replace the various washers and nuts belonging to the valve and tire bolts and screw all home. After this, fully inflate the tire, and as it gets harder continue to screw up the valve nut and the butterfly nuts securing the bolts. After the car has run a short distance, these bolts are likely to settle home to such an extent as to become loose again. It is, therefore, well to stop and screw up tightly. If difficulty is experienced in getting the valve to project far enough through the felloe to enable the outside nut to bite, knead and thump the cover just over and alongside the valve with the hands before the tire has become thoroughly inflated. If, in spite of this, it will not come through, it is possible that the stem of the valve is strained against the side of the hole, and it will be necessary to take off the bead of the cover near the valve again and re-arrange the tube.

4. **Fitting a New Casing**—This is a heavy job, and the use of special tire manipulators is almost essential. After having detached the outside edge, as already described, the tire bolts and air tube must be removed, the tire manipulator being made use of to lever the cover away from the holes in the rim, thus leaving room for the easy removal of the bolts and valve. To complete the removal of the old cover, detach the second or inner edge by pulling the cover towards you with your left hand. As soon as the bead has partly left the clinch of the rim, drive the detaching lever under the edge already freed and then under the second. Lower the lever towards the spokes of the wheel, drawing the cover outward with your left hand.

As soon as about eight inches of the cover have been completely released from the rim, you can take the rest out with your hand.

Before fitting the new casing, rub the beads with French chalk to facilitate their slipping into position, and polish the inside of the rim thoroughly with blacklead, using a stiff brush for the purpose. Then turn the wheel round until the hole in the rim for the valve is on top, and insert a spigot of wood or dummy valve, forcing it well home. Then take the cover with the valve slit on top and the smaller diameter bead towards you (in the case of tires where there is a slight difference between the size of the two beads), place it on the rim so that the valve slit coincides with the dummy valve, and with the two hands try to fit the bead around the rim as far as possible. Insert the right hand inside the cover at the spot where the cover has refused to go further on the rim, and with the fingers closed and the palm pressing on the inside bead, try to force a further portion of the bead into the clinch of the rim. Towards the end of the operation, when this becomes too hard to do by hand, use the flat end of the lever by inserting it between the bead and the rim. Do not remove the dummy valve until replacing the inner tube.

The greatest difficulty is to get the slits in the beaded edges corresponding to the position of the valve and bolts into place. They should not vary the smallest fraction, and if there is any sign of a strain on the side of the valve or bolts, the operator must work the cover round until they are quite free.

The valve and security bolts will have to be replaced with the aid of the forked manipulator, the latter being used to raise the outer bead of the cover out of the way and at the same time push the inner bead away from the center of the rim. The outer edge of the shoe is then replaced in the outer clinch of the rim, as already described. The operation of getting on a new cover, as a rule, entails much kneading and thumping with the hands, which seem to have the effect of increasing its flexibility.

The tire bolts should have leather, rubber, or canvas washers at the base to prevent water reaching the inside of the tire, and the operator should make sure that the wing nuts have gone right home, and are not in reality only screwed up to a position where the thread jams on the bolts, so that the heads of the bolts inside the tire are not gripping the beads. To guard against such a contingency, it is well to ascertain before putting new bolts into a tire that the wing nuts are easy fits on the bolts all the way up.

5. **Removing Air Tube**—Dismantle the valve. With the left hand take hold of the free edge of the cover which is opposite the valve, the palm of the hand being against the edge and the fingers extended inside the cover. Gently draw the inner tube with your right hand, going round the whole length of the tire and taking great care not to tear the tube. If the tube appears to adhere to the cover, hold it closely and pull cautiously. Then only the part of the inner tube on which the valve is fitted will remain in the rim. The special manipulator should now be brought into operation in order to lever the outer edge of the cover back and at the same time keep the inner bead clear of the valve, as described farther on.

6. **Replacing Air Tube or Fitting a New One**—Before commencing to replace the air tube, carefully clean out the inside of the shoe. Then rub a small quantity of French chalk over the inner surface, and apply French chalk to the air tube also. Use the manipulator to push back the outer bead of the cover and to keep the inner bead from covering the valve hole in the rim. Then fit the valve in position.

To place the inner tube evenly round the cover, see that the heads of the tire bolts rest flat on the rim, and raise the free edge of the cover with the left hand about ten inches to the right or to the left of the valve, to make way for the inner tube. Take the tube in the right hand, the thumb being on the top, and with the end of the extended fingers push the tube well down inside the cover, which should be raised as much as possible with the left hand to allow the right hand to enter the cover as far as it can. Go on adjusting the inner

tube by sections of ten inches, taking great care not to stretch or twist it, and as each new portion is inserted gently, draw it towards the length that has just been placed in position. It is essential that the tube should not be stretched in the operation or it will overlap in folds when the last section has been inserted. When the inner tube is deflated it always seems too large for the cover.

Having got the tube in position, inflate slightly. Slide the hand between the rim and the tube to make sure that the tube is not bunched up in one part and stretched in another, twisted, creased, or nipped under valve or bolts, and see that the canvas covering the tire bolt head is not creased or wrinkled. Then replace cover as already described, taking care that the air tube is not nipped between the bead and the rim in the process. To minimize this risk, be very careful to ascertain that the two tire bolts in the immediate neighborhood of the length of beading which is being inserted are pushed up in the tire as far as they will go and held in this position.

If the operator is not absolutely sure that the air tube is not nipped under the bead of the rim, he should carry out the following test: Grasp the cover with one hand, the palm being near the bead. Push the cover towards the car. Use the point of a lever held in the other hand to raise and push back the bead towards the center of the rim. Examine the space inside the rim between the edge of the rim and the bead of the cover. Be especially careful to examine the last portion of the bead fitted. If the color of the tube is revealed, it indicates a nip, and a detaching lever must be inserted at the place and operated as when taking off a cover. Then allow the bead to return to its place, and carefully ascertain whether the operation has got rid of the nip. Replace the bead and continue the test all round the tire. To check for nips caused by tire bolts and valve, it is sufficient once the second bead is in position to press the valve and the stems of the bolts inward, allowing the air pressure in the tube to return them to their places.

Fig. 1 shows the inner tube nipped under one corner of the beaded edge of the tire.

Fig. 2 shows how the inner tube may be nipped between the side of the tire bolt and the inside of the bead of the tire.

Fig. 3 shows how it may be nipped similarly between the head of the valve and the inside of the beaded edge of the tire



Fig 1.

Fig. 2.

Fig 3.

In all these cases considerable injury will be done to the inner tube.

A nip may easily be caused through the stem of a tire bolt being bent. Under such circumstances, it may stick in the felloe, or, owing to its being bent, the tube may slip under the head, resulting in a small burst. A bent bolt, therefore, should always be replaced with a new one. If the leather on the head is creased and cannot be smoothed out, a new bolt should be substituted. The butterfly nut should be tightened by hand and not with pincers, and on no account should the bolt or valve be hammered unless with a block of wood between as a buffer, and then only as a last resource.

It is a wise precaution, before inserting the tube, to see that the nut holding the valve seat in place on the tube is screwed up tight, as it sometimes shakes loose while in the tire bag, owing to vibration.

7. **Repairing a Puncture**—It is always advisable to carry spare air tubes, and to insert one in place of the punctured one. The puncture can then be repaired at leisure, preferably with the aid of a vulcanizer; but if a tube is not available, a fairly satisfactory job can be made with a rubber patch and solution as follows: Carefully rub the air tube for a considerable space round the puncture with sandpaper, then clean

with gasolene, and while still damp scrape with the blade of a knife held edge downward. A rubber patch of suitable size should be treated similarly. Next spread with the fingers a thin layer of solution over the patch and the prepared portion of the air tube. If it is at all thick, or there are any blobs, the air will force its way out when the tire has been running for a little while, and has become hot. After spreading the solution, lay the patch and air tube aside to dry, and, after waiting for fifteen or twenty minutes, touch the surface lightly with the finger. If either patch or air tube adheres, the solution is not yet dry enough, and the operator should wait until it becomes so dry that it does not stick to the finger. Then apply the patch carefully, smoothing it into position until it lies quite flat, and without creases. Roll it under pressure with the chalk cylinder, and if possible put it between two flat and heavy surfaces for a few minutes. The patch should be well sprinkled with chalk before the tube is replaced in the casing, shoe or cover.

It is, however, far safer to repair the puncture in the motor house at one's leisure. The solution on patch and tube should be left to dry for several hours, or even for an entire night. The patch should then be rolled into position, and the repaired portion, having been placed between two boards, should be left in the vise under moderate pressure for an hour.

A vulcanized repair is, of course, more reliable, and can easily be effected by following the printed directions in the booklets issued by the manufacturers of vulcanizers.

The following system of effecting a roadside repair is successful if properly carried out: Thoroughly clean both patch and tube with sandpaper, and apply three coats of solution to both, allowing the two first coats to become quite dry before putting on the next. When the third coat has become almost dry, pass a brush or pad of cloth thoroughly wet with sulphureted hydrogen over the solution on the inner tube, and press the patch instantly in its place, when the repair is complete and the tube can be used at once. The most important point in this method of repair is that the patch must be placed on the

tube within ten seconds from the application of the sulphureted hydrogen, as otherwise it will not be successful.

Wheel rims should occasionally be examined for dents or bulges, as these defects cause the edges of the rim to have a decided cutting action on the beaded edge of the casing. Especially is this the case when the car has been driven on a flat tire, as the rim is then more liable to damage. If the edge has been flattened it is best to have it attended to by a competent man, but bulges, on the other hand, can be gently tapped back into shape, care being taken not to mark the metal with the hammer. Afterward, the part which has been operated upon should be touched up with paint and well varnished, otherwise the rim will rust, causing injury to the casing.

If possible, avoid driving on a deflated tire; it will ruin both cover and air tube, and may so dent the rim as to render the fitting of a new cover difficult, and when fitted, to set up internal wear. If there is no spare cover on board the car and the injury is beyond roadside repair, remove the air tube, and while one side of the cover is out of the rim, stuff the inside with rope, felt, or such like. Then carefully replace the cover in the usual way, and screw home the butterfly nuts firmly.

A driver once made a most effective temporary repair in the following way: Securing some rope, he cut it so as to somewhat exceed in length the circumference of the tire, and then formed a loop on one end. He next procured a quantity of felt, and bound it neatly round the rope, until the bulk was sufficient to make a comparatively tight fit inside the cover. This makeshift was then laid on the rim, the end of the rope placed through the loop, and having been pulled taut, was secured. Then the cover was replaced, and the tire was found to act admirably. Of course, it was "dead," and there was a distinct bump at the point where the joint in the rope occurred. It was, however, almost as comfortable as a solid tire, and protected the rim perfectly. For a comparatively short distance a car might be so driven without even causing injury to the cover.

Another system which can be recommended is to wholly re-

move air tube and cover and twist a length of rope round and round the rim, splicing the ends and wiring in position.

Some types of tires depend altogether on mechanical fastening. To detach these is a plain, straightforward job. In replacing them, the same care should be taken to prevent the tube from being nipped. It is also necessary that when an annular band is used it should be replaced in the same position, and to insure this it is well to mark both the band and the rim. In every case the special booklets describing these tires should be procured.

8. Repairing Casings—This is essentially a case where prevention is better than cure. A burst is caused, in the great majority of cases, by wet penetrating through a cut in the rubber and gradually rotting the fabric; or through the strands of the fabric getting cut by the sawing action set up between them. As regards the first cause of failure, the remedy is to repair the cuts as soon as they appear, in the manner hereinafter described. As regards the second cause of failure, it is generally due to the tires being used too slack, thus causing excessive flexion.

Whatever the cause, an impending burst is generally notified by a boil or slight swelling at the weak spot, and the moment such becomes apparent the outer edge of the cover should be removed for the purpose of inspecting the fabric. If it is found that the fabric is failing, the driver should affix a gaiter over the outer cover at the weak spot to enable him to get home and carry out a permanent repair. If a burst actually occurs, a piece of canvas should be cut long enough to extend about eight inches beyond the burst, and wide enough when bent round in a tube to considerably exceed the circumference of the tire. This canvas should be inserted between one edge of the cover and the rim. It should be pulled over the air tube as it lies flat on the rim, and then should be pulled out under the other edge of the cover. The canvas should next be manipulated until it rests snugly and closely inside the cover, forming a close-fitting envelope between it and the air tube, the edges, of course, extending beyond both beaded

edges of the cover. The beaded edges should then be replaced in the rim, with the edges of the canvas protruding at both sides, and the tire inflated. If the job is properly performed, the canvas will adapt itself exactly to the size of the tire, and take the strain at the burst portion. If it is a bad fit, that portion where the tire burst is will be either smaller than the rest of the tire or larger. In either case the tire should be deflated, and the operator should try again. It is a wise precaution to fit a sleeve over the faulty portion of the casing for additional security.

To make a permanent repair the use of a vulcanizer is, as a rule, necessary. In most towns there is an expert in the art, who can be relied upon to do the work satisfactorily, or the tire can be sent to the makers. Many automobile owners keep a vulcanizer in their garages, and if the chauffeur is expert it will prove a profitable investment.

If a burst has to be repaired on tour and no vulcanizer is available, a more durable job can be effected as follows: Remove the cover from the rim. Remove all the decayed or faulty portion of the first or innermost layer of fabric; then remove in succession smaller portions of the next layers, reducing the size in proportion until the one next the rubber is reached. Then remove all French chalk or dirt and thoroughly wash the fabric and rubber about the burst with a rag soaked in gasolene. Next cut a piece of rubber to fit the innermost aperture, and also portions of canvas to exactly fit the various apertures in the successive layers of fabric. Solution these patches on both sides and leave to dry for about twenty minutes. Also thoroughly solution the exposed surfaces of the burst, working the solution between the layers of fabric where possible. Now place the rubber patch first in position so as to exclude the wet, and after that the canvas patches in succession. Use pressure to insure firm contact. A rounded wooden block is the best means. To complete the job take a larger piece of canvas of the size and shape recommended when temporarily repairing a burst. Solution one side, and also spread a coat of solution over the existing patches as

they rest in place and for several inches on both sides of them. Let the solution dry for twenty minutes, and then place the canvas patch, solutioned side downward, carefully in position, bringing the edges well over the beaded edges of the cover. Avoid creasing, as any unevenness will set up friction and chafe the air tube. Scatter French chalk over the repair and replace the casing.

In some cases boils are superficial, being caused by dirt and grit penetrating through a small cut in the cover and working their way between the rubber and the fabric. These should be attended to at once. The grit should first be carefully removed by a blunt instrument—the flattened end of a match will do. The fabric and rubber where they have parted company should then be cleaned with gasolene or benzene as far as possible, and solution should be carefully worked in. It would be advisable to allow the solution to stand for a few minutes to become tacky. The rubber should then be firmly pressed downwards and tape wound round the tire so as to press the rubber at the damaged spot firmly against the fabric. The tape should be left in position for several hours, during which period the car should not be used.

As already mentioned, cuts in the rubber of the outer cover, even if only nail holes, should be repaired at once, if possible on the very day they are discovered. The only really effective method is by vulcanizing, and every motorist should carry one of the excellent little car vulcanizers now on the market. Full instructions are supplied with the vulcanizers.

Those who, from mistaken ideas of economy, do not invest in this useful appliance will have to try one of the many special preparations now on the market. We will describe the method of application. Clean all dirt out of the cut and scrape both sides with the blade of a knife, if necessary trimming the jagged edges. Then wash thoroughly with gasolene or benzene. Next fill the cut with a layer of the preparation, and after allowing fifteen minutes for it to dry, add successive layers until the surface is quite flush. The repair should be left for

twenty-four hours to set. If properly applied, such a repair is generally effective, but cannot be relied upon absolutely.

9. **Valve Troubles**—The non-return valve of a pneumatic automobile tire is in principle and general construction almost the same as the valve of a bicycle tire, with which it is presumed our readers are acquainted.

One common type of valve which is now fitted to motor-car tires, consists of a hollow stem A into which fits the valve proper, B. This consists of a hollow spindle, having at its top end a conical seat O. Inside the spindle is loosely fitted a small wire or pin J, having at its top end a cone of vulcanized rubber. This cone forms a valve, and fits into the conical seating O in the top end of the hollow spindle.

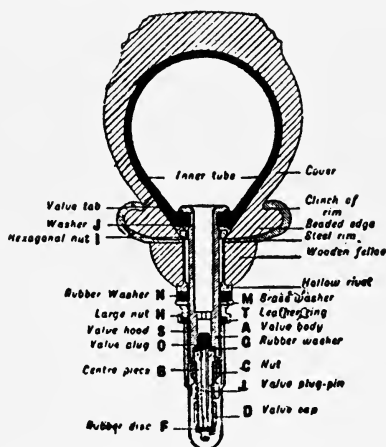

FIG. 4.—TYPICAL TIRE VALVE.

On the hollow spindle is a shoulder, against which is a rubber washer G. The spindle is kept pressed down into the valve stem by a screwed gland C, and an air-tight joint is made between the rubber washer and a shoulder inside the valve stem. The outside end of the spindle is threaded to take a pump connection.

Leaky valves occasionally cause trouble. In the case of

the Michelin type, which is in very general use, there are four points which need careful attention.

First, the rubber plug O (which, we might mention, is not absolutely air-tight until the cap D has been screwed on). Should there be a definite leak, the rubber plug, its pin, and its seating should be cleaned, a little French chalk first having been rubbed on the operator's hands. If the plug is actually damaged, it should be replaced with a new one. The rubber disk F in the bottom of the screw cap D is intended to provide against small leakages at O. If it is damaged, it should be replaced. If a spare disk is not at hand, a well-fitted ring of leather or cloth soaked in grease will prove effective. Sometimes the air may escape at the rubber ring or washer G. This is due to the nut C holding the center piece B and forming a rubber joint between the valve stem and the air tube, not being screwed down tightly enough so as to compress the rubber ring G between the center piece B and the valve body A. If the rubber in the ring G is perished, it should be at once replaced. A ring of leather or thread smeared with tallow will do in an emergency. Sometimes the nut I may have worked loose, which may often cause an escape of air; it should be screwed up, but not too tightly, or it may split the air tube. The best way to definitely detect a leak in the valve is to turn the wheel until the valve cap points downward, and then immerse the valve in a glass of water. If air bubbles rise, the valve is leaking. The valve parts should be tightened by hand, as they do not require great pressure.

Care in seeing that the rubber cones and washers are in good condition and not perished, and that no dirt or grit or other foreign matter gets into the valve, is all that is necessary in keeping the valves in order. On no account should any oil be used near any tire valve. It attracts dirt and grit, and very soon perishes the rubber and causes leaks.

10. **The Actuating Levers**—A typical set of tire tools consists of the following articles:

Three levers for removing and replacing bead.

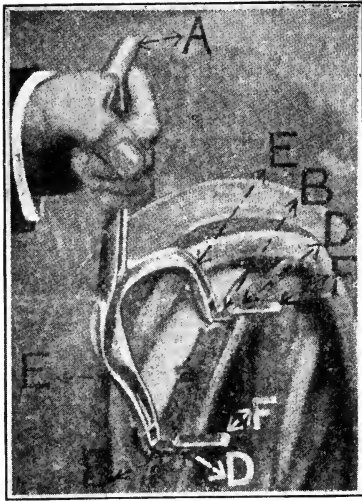

Fig. 6—Clearing Valve Hole or
Tire Bolt Hole.

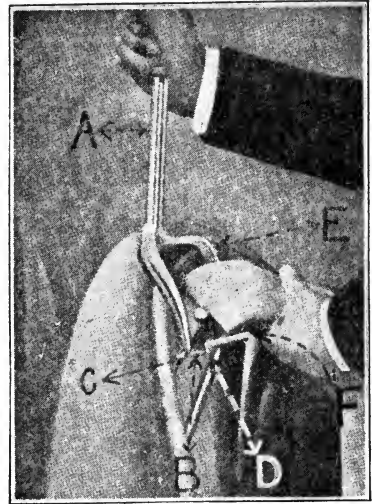
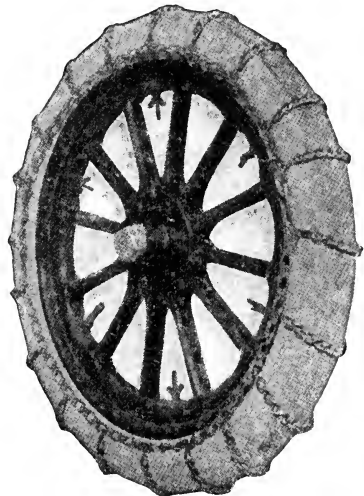
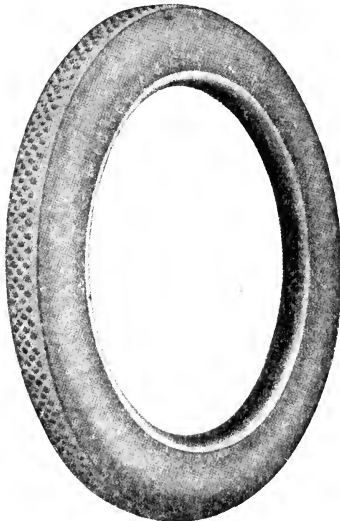
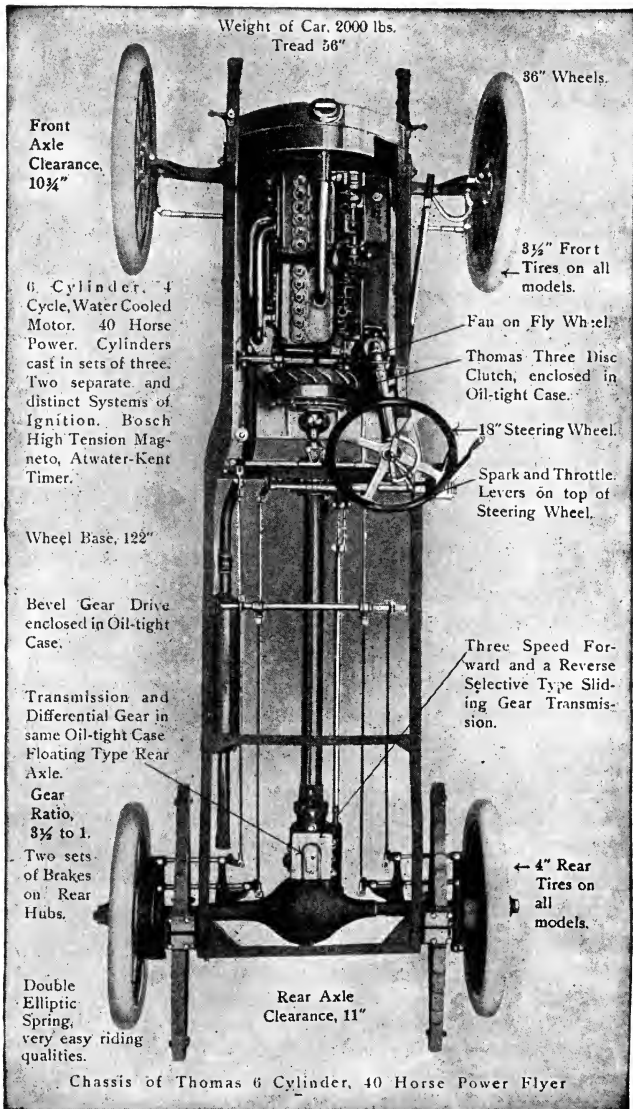

Fig. 7—Valve in Act of Being Re-
moved or Replaced.



Studded Band and Chain Non-Skids.



The 6-40 Thomas Flyer Chassis.

Forked manipulator for moving bead out of the way when removing or replacing valve or security bolts.

The manipulator consists of a forked lever A (Fig. 5) and two strut pieces, one shown at B, hinged at C, and with

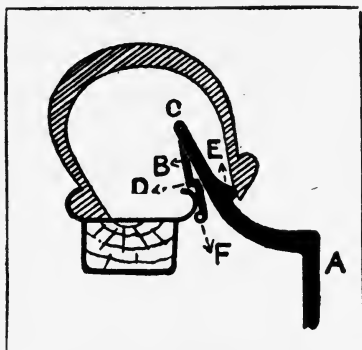

Fig. 5.—A Tire Manipulator.

shoulders D and E, which bear against the clinch of the rim and the bead of the tire respectively. In Fig. 5 the manipulator has been inserted under the bead of the tire.

Fig. 6 (a photographic illustration on another page) shows the manipulator after having been inserted under the edge of the cover, and pushed home until the shoulders D, D have found their seating on the edge of the rim. It will be noticed that F, F are the strut pieces hinged at C, while the shoulders E, E, acting against the bead of the outer cover, force it upwards as the lever handle is raised. The manipulator is now in the correct position for fitting the valve or security bolt, and in this illustration the "raison d'être" of the appliance will be seen. The hinged portion C bears firmly against the bead of the opposite side of the cover, and so prevents it from slipping down and covering the hole. It will be noticed that the shoulders D, D obtain a firm purchase against the edge of the rim, while the shoulders E, E engage with the edge of the cover, which has been removed from the rim, and holds it absolutely out of the way, the leverage obtained being enormous.

Fig. 7 (also a photograph) shows the air valve in the act of being either removed or replaced. To extricate the manipulator, it is only necessary to dip the end of the lever A and pull it out. This manipulator is adaptable to all sizes of tires. For those of 105 millimeters and upward the strut pieces are reversed.

Many other ingenious devices are also made and sold for the purpose of facilitating tire repairs and adjustments, and each type has its own points of advantage. The use of suitable tools for the purpose and the proper application of them prevents damage being done to tires when excessive force is used.

VALVES.

Symptoms: Failure of engine to start.—Diminished Power.—Partial or total loss of compression.—Popping.—Misfires.

Causes—Valves: Pitted, or bearing surface warped.—Bent spindle.—Broken spring.—Weak spring.—Valve stuck through guide getting clogged or spindle bent.—Too little or too much clearance between stem and plunger.—Valve broken.—Dirt under seat.—Foreign matter wedged between valve and seating and causing leakage.—Springs in different cylinders of irregular tension (only in the case of engines with automatically operated inlet valves).

Both the inlet and exhaust valves are apt to get sooty and gummy, especially if the engine is over-lubricated or overheated. This will affect the power of an engine fitted with automatic valves by making them open sluggishly. If about a teaspoonful of kerosene is squirted into each cylinder daily, and the starting handle given a few turns, it will have a very cleansing effect both on valves and piston rings, and will also facilitate starting.

Grinding—Even when every care is exercised, the valves become pitted or worn in process of time, with the result that the compression is affected, and the engine loses power. Grinding is the remedy.

To grind a valve, remove the cross key which passes through its stem, having first raised the hollow cup washer, which prevents the cross key from slipping. This is best done by the aid of a valve spring lifter, many types of which are on

the market. Then take off the spring and push the stem upward till the head emerges through the valve cover opening.

Much difficulty is often experienced in removing or replacing a valve spring, owing to the necessity for compressing the spring when the cotter, which fills the oblong slot in the valve stem, is being put into position. A very simple way to get over this trouble is to compress the spring in a vise before replacing it, and then secure it in the position assumed by means of a thin wire. The spring can then be easily replaced, and when the cross piece is in place the wire can be cut and the spring will assume its normal position.

Having removed the valve, smear the seating—which is usually part of the cylinder itself—with a mixture of oil and emery powder, or corundum powder, or corn emery. Then replace the valve on its seat. Having plugged up the opening to the combustion chamber with cotton-wool or waste to prevent the emery getting in and scoring the cylinder, proceed to grind the valve on to its seating. Specially made grinding-in tools can be purchased for the purpose, but an ordinary screwdriver will do. The operation is performed by oscillating the valve on its seat, at the same time lifting it occasionally from its seat so that it sits down in a different position. It must be repeated until a true face fit is obtained, and is complete when a clear white line is shown of even width around the valve seat and the valve head.

Then remove the valve and wash out all the emery paste from the entrance to the combustion chamber. Next remove the cotton, and replace the valve, having first thoroughly cleaned the stem and washed it in gasolene. If the stem is dirty, rough, or a very tight fit, polish it with fine emery cloth to prevent all danger of its sticking in the guide. See also that the guide is clean and lubricated. A new valve must be similarly faced to its seat or it will not be compression-tight.

If there is not any very great improvement in the compression just at first, the motorist must not be disappointed. It takes some little time before a newly-ground valve becomes perfectly gas-tight.

After successive grindings, it is sometimes found that the valves sit so far down on their seatings that the stems make firm contact with the plungers which lift them, and thus prevent the valves from properly closing. To remedy this, sufficient should be ground off the end of the valve stem to prevent it coming into contact with the top of the plunger when the latter is at the lowest point. It should be borne in mind that, owing to the expansion caused by the heat, the valve stem may clear the plunger when cold, but touch it when the engine is working. Therefore, this adjustment should be made when the engine is hot, and, where adjustable plungers are used, it is best to make the adjustment in the plunger rather than to grind the end of the valve stem. When the valve is seated, the plunger at the bottom of its stroke and the engine hot, there should just be daylight between the top of the plunger and the bottom of the valve stem. In multi-cylindered engines it is important that the distance between plunger head and the bottom of valve stem should be the same for all cylinders both for exhaust and inlet valves. In cases where the stem is too short and the exhaust valve does not open enough, thus causing back pressure, a new valve should be fitted.

Should the cotter holding the spring of the valve work out of place, the spring will cease to act, and the valve will become inoperative. The piston will then cease to draw in its charge of gas. If the spring is too weak, the valve will return to its seating sluggishly, thus allowing burnt gases to be sucked back on the next suction stroke, and affecting the power of the engine. A new spring is the remedy. Overheating or long usage will affect the temper of the spring and weaken it. This trouble may be tested for by placing the end of a turnscrew between the upper coils of the spring and exerting a downward pull on same. If the motor picks up speed, it may be taken as an indication that the spring has lost its correct tension.

Too great a clearance between the valve stem and its plunger will cause insufficient lift and account for sluggish running and overheating. Remedy, place a thin cap on the top of the

plunger rod, that is, if it is not already provided with a screw cap to take up the wear. A worm cam or plunger roller will also effect the opening of the valve; a 1-16 inch reduction will be sufficient to appreciably alter the time of opening and its duration; the effect will be to produce overheating and sluggish running. Some types of cams are more prone to rapid wear than others; the ideal one is that which has its profile so shaped as to lift the valve without excessive side thrust on the tappet head or roller, and so "backed off" as to insure a prompt closing without undue clatter or shock to the valve head. The length of the cam's lifting surface should be sufficient to insure the valve being held fully open until the completion of the exhaust stroke. In modern engines the wear on the cam and roller is very slight indeed.

A broken exhaust or inlet valve will instantly lead to a total loss of compression in the cylinder. The engine should be stopped at once, or the broken parts may get jammed in the combustion chamber and do damage. The bits should be carefully removed. If difficulty is experienced a bent wire is useful. Small particles can be got up with the aid of some sticky material, such as pitch or cobbler's wax, smeared on to the end of the wire.

In the case of the automatically operated inlet valve, where the suction in the cylinder opens the valve against the pressure of a spring—a method now practically discarded except in the case of some motorcycle engines—no very definite rule can be laid down as to the exact resistance of the spring suited for every form of valve. Generally speaking, the practice is to use a spring which errs on the heavy or strong side. Such a spring will prove a trifle sluggish on starting the engine, but will function correctly when the speed has been accelerated. Compared with a slack or light inlet spring, the mixture volume will remain more constant, as there will be no puffing back at the carbureter.

In multi-cylinder engines, if the springs of the automatically-operated inlet valves are not of equal tension the power of the engine will be affected. To test the tension, remove the

valves, and taking one in each hand, press the spindles against each other. If the valves open simultaneously the springs have an equal tension. A slight difference is not of great consequence.

The springs may have lost their elasticity, due to excessive heat. They should then be tested against a new spring.

As to the best time for opening and closing the valves, practice varies, and the reader is referred to the table given in the article on "Timing" in letter T. In this matter so much depends on design—for example, valve area, placing of valves, and nature of the valve pockets, together with the cubical capacity of the cylinder, compression degree, and intended normal engine speed—that it is only possible to generalize.

WATER CIRCULATION.

Symptoms: Overheating.—Sluggish running.—Steam.

Causes: Pump.—Defective.—Broken.—Spindle locked or friction-wheel not working or slipping.—Chain broken or detached (in chain drive).—Worn washers, valves, or bearings.—Grease in pump.—Frozen pump.

Pipes: Choked.—Broken.—Leaking.—Air-bound or Steam-bound.

Radiator: Grease or other deposit.—Mud in gills.—Improper proportion between the amount of water and the cooling surface of radiator.

Fan: Belt slipping or breaking.

Water Jacket: Leaks.—Deposit

Any failure in the water circulation, unless detected at once, will cause overheating, the results of which may prove very serious. For this reason a careful watch should be kept on the water pressure gauge; but if that useful index is not fitted, the engine and pipes should be felt by hand. Should the car begin to run sluggishly the test tap should be opened where such is fitted, or some means found of discovering if the usual volume of water is circulating. Steam rising from the vent-hole in tank or radiators is a sign that the temperature is getting dangerously high. That the circulation is going on properly can be generally seen by opening the filling

cap on the top of the radiator. In case of failure, the following are the points to look to for defects:

(a) **The Pump**—Should the pump not be functioning properly, it will be comparatively cool to the touch as compared with the water jacket and pipes. If the drive is by friction-wheel, see that the wheel is not slipping. If it is, slightly tension the spring so as to make the contact just sufficient to fully overcome the vibration of the road. Over-tightening only brings a severe strain on the pump bearings, and may render the spindle useless, or destroy the ball races if such be fitted. If the leather on the wheel is greasy, carefully clean it and the part of the flywheel against which it bears with gasoline or kerosene. See that the spindle has not seized in its bearings for lack of lubrication. The friction-driven pump is now seldom fitted.

If a chain drive, the chain might break or come off, which is generally due to undue slackness. It should be adjusted until there is a just perceptible sag. If the pump is gear-driven, there is not so much danger of trouble, though the key or the coupling by which it is driven may shear or come adrift.

The drive being right, the next point to make sure of is that the internal economy of the pump is in order.

Centrifugal and cog-wheel pumps are the two types most in use for motor cars. The first requires a higher speed than that which is necessary for the latter. As the centrifugal pump is merely a fan-wheel revolving in an inclosed chamber, there is practically nothing to get out of order, and from this point of view it is better than the other, but its high speed is trying to the bearings, and it is these that cause trouble with this type of pump. Dirt may possibly get in, but a thorough washing out will remedy this. If grit is allowed to remain in the pump it may wear the bearings and affect its efficiency. The application of a hose is generally effective. The bearings are usually of the plain type, and if in proper order the friction set up in them is very slight. They should be kept well greased with a grease pump, and if any heat is noticeable the car should not be run till the cause is ascertained.

For the efficient working of a cog-wheel pump it is necessary that there should be but a slight suspicion of side play—that is, between the flanges of the pump casing and the side of the cog-wheels. A curious species of trouble in some types of this class of pump is set up by the shearing of the pins or keys fixing the wheels on the spindles. In modern practice the drive between the engine shaft and the pump spindle is so arranged as to be in sight and easily removable, so that there is no difficulty in seeing if the pump is working.

A slight leakage of water is not of much consequence. If, however, the leak is bad, see that the grease cup is thoroughly full, and screw the top partially home. Also see that the packing gland nut is tight. If the packing wears, it will have to be replaced. Tallow, greased with tallow, makes the best packing. It is well, when testing the pump, to run the engine at its normal speed, as the velocity of the water from the pump to the jacket varies with the speed of the engine.

(b) Danger from Frost—If the pump freezes and the engine is started it will probably result in the shearing of the key, and also damage to the key way. A temporary roadside repair may be effected, but it is really a job for a skilled mechanic, as it is essential that the key should be a perfect fit in the key way and boss.

When the temperature is below freezing point there is the danger of the water freezing in the circulation system, which often results in cracked water jackets or burst pipes.

Many motorists have had their water jackets, pipes, etc., ruined from this cause, and incurred great expense thereby. The only safe remedy is to have the garage heated, by means of hot air, hot water, etc., as in the ordinary conservatory. Such an installment, however, may entail a great deal of expense, but the difficulty can be got over in a much simpler and cheaper manner by using one of the stoves which burn a special fuel. In one such stove used in Europe, the fuel is in the form of small cylinders. Two or three of these are placed in a fire for a few minutes; they are then put into the lower portion of the stove, and other cylinders piled on top.

A single charge will last an entire night, and the heat can be controlled to a nicety by varying the air inlet. The fuel only smolders, and will not ignite gasolene. In fact, gasolene, it is said, can be poured over one of these stoves without any ill result. For this reason the insurance companies permit their use. Apart altogether from the danger of freezing, the use of these stoves, by making the atmosphere comparatively dry and equable in the motor house, is a saving to the carriage work, upholstery, tires, etc. This applies of course to private garages, public garages being usually properly heated.

When touring, however, or away from home, a heated garage is sometimes hard to find, in fact it is seldom available. Under such circumstances the car should be run into the house provided for it so that the front portion will occupy the farthest corner from the entrance, and the water should be drawn out of the water system as far as possible. In letting the water off, the cap of the filling pipe should be unscrewed. The pipe leading from the water jacket should be opened, and also the cock of the pipe leading from the radiator to tank. If there is a cock or plug to the radiator, this should also be left open to insure the last drop of water draining away, and also the cocks or plugs often used to drain the water jackets. It is not sufficient to open a cock somewhere in the circulating system without making quite sure that the cock in question is at the lowest point, for very often cocks are fitted merely for testing the circulation, or washing out purposes, and are not in the right position to entirely drain the system. It is sometimes impossible to completely drain the pump, so in frosty weather it is well, before starting, to gently heat the metal casing by means of hot cloths, etc., in order to get rid of any ice that might interfere with its proper working, and which sometimes results in the driving spindle shearing off. Should the carbureter be water-jacketed, the freezing of the water will, in most cases, burst the jacket.

In very many cases, however, it is impossible to entirely empty the water system, and even a very trifling amount of liquid at the bottom of the water jacket, or in the pump, may

cause serious damage. We have known of a case where a sandy deposit in the bottom of the jacket has retained sufficient moisture to burst it. It is possible also that the taps may be choked. For this reason we should recommend the motorist to pile all available rugs over the engine bonnet. This will prevent freezing unless the frost is very severe. In the latter case the only really safe method is to use some preparation calculated to entirely prevent freezing.

By adding chemicals to the water the freezing point is lowered, and if the water were always kept at a very low temperature the number of substances that could be added without injury to the pipes, etc., would be fairly large, but the number is limited by the fact that during the working of the engine the temperature is raised to nearly boiling point. This heat is quite sufficient to decompose many of the added substances, setting free agents which would attack and eat away the metal of the pipes and tanks. The safest, but most expensive, substance to add to the circulating water is glycerine; but it must be kept in mind that fresh glycerine must be occasionally added to make up for the losses which occur through the glycerine being carried off with the steam. Calcium chloride can also be used for the same purpose; it is cheap, easily obtainable, and it is stated by those who have used it to be innocuous.

(c) **The Pipes and Connections**—An air-lock in the pipes is exceedingly difficult to diagnose, in that it frequently only partially interferes with the water circulation. In the majority of modern cars there is little danger of an air-lock being formed, but with the older forms of vehicle with the low down radiator and a separate water tank it may occur. If an air-lock is suspected it is best to open every available water or air orifice and thoroughly drain out all water and fill up again with these openings only partially closed so as to allow the air to escape as the water comes in.

Leaking or broken pipes can easily be mended temporarily by connecting the fractured parts with a piece of rubber tubing, wired into position, and for this purpose suitable tubing

should always be carried. Although a fairly good job can be made by means of wiring, it is much better to use a band, such as supplied by many dealers. A patented clip is made of a single strip of copper, broadened at one end, which is provided with a slot, through which the strip is passed and wrapped a second time round the rubber pipe, the usual screw and flynut drawing the ends tight and insuring a perfectly concentric grip of the pipe. The head of the screw is square and bears against a flat shoulder on the copper strip, so that when once pushed in, the screw will not turn round; thus there is no need to hold the end of the screw with spanner, pliers or screwdriver when turning the flynut home.

Where a long length of flexible pipe is necessary, the use of wire-armored rubber hose instead of metal pipes will minimize the risk of breakage or leakage. This hose accommodates itself to vibration, and causes but little strain on the unions.

It is advisable also to occasionally renew such hose connections, especially if there has been any prolonged overheating of the pipes and radiator, as such will rapidly cause the rubber to disintegrate or parboil, the result being that particles will find their way into the passages and possibly cause failure at the pump later. For the same reason the motorist should use only the best quality armored or unarmored steam hose, as he prefers.

In using armored hose, trouble is sometimes experienced with the ends of the wire coil which forms the armor around the tube becoming loose and straggling away from the tube. The best way to overcome this is to bend the last turn of the coil upon itself and fix with a blob of soft tinsmith's solder.

A leaking faced joint can be temporarily repaired by smearing the two faces with boiled linseed oil and a coating of white lead before putting together; but a "faced" joint should when possible be treated as such, and re-faced by competent hands when repair is called for.

Should a pipe break about the union which secures it to the cylinder, a temporary repair may, in many cases, be ef-

fectured by binding thin rubber tubing, such as is used for bicycle tubes, round the union and nut and wiring it on to the broken end of the pipe. Even sheet rubber can be made to do service, and a strong rubber band is an excellent thing for securing it to the union socket. Of course the weight will have to be taken off this joint by means of wire supports or otherwise.

(d) **The Radiator**—Very often the radiator is at fault, being insufficient to cool the water. Deposit may get into the radiator from the pump or otherwise, but if water is used which is free from lime and foreign matter of that kind rust may result, but very little scale. If, on the other hand, the water is limy or chalky there is not much rust, but a lot of scale. Either can be got rid of by a thorough swilling through with a strong solution of soda. The solution should be left in for an hour or two and then run off, and if much deposit comes away another dose should be given. Rain water is best, provided it is put through a strainer. One authority says that he has never found that rust mattered much. In fact, he has come to the conclusion that the best thing to do is to let rust form and not to change the water any time unless it gets thick.

The motorist should be careful when buying his car to see that adequate means for dealing with so important a matter as flushing or cleaning exist. A radiator without such provision is much akin to a boiler without a manhole or mud doors. Needless to say, such would not pass an inspector. It is to be recommended that the radiator be systematically flushed periodically—say in the case of a much-used car every month or so—but as much depends on local circumstances, for example, nature of the water, type of radiator, and the disposition of the same on the car, only an approximate rule can be given. A honeycomb radiator requires careful treatment as regards cleaning. With some of them it would seem impossible to internally cleanse them, and when they become so furred as to seriously fail in their work it will be the

cheaper, and often the only method, to get a competent mechanic to deal with the job.

It is necessary to see that the radiator is not choked on the outside with dust or mud.

Leakages may usually be stopped by the use of a soldering bit with resin as a flux. A useful combined solder and resin is sold in sticks, and one of these should be carried on a car. Any tinsmith is competent to staunch a leak or effect repair to the common form of radiator, but the honeycomb type requires most careful treatment, lest in tightening one tube a whole series may be made leaky. It is essentially special work, and should be referred to some maker of motor fittings. For temporary repairs to leaking pipes, or tubular radiators, a useful remedy will be found in mixing genuine white lead with a dusting of litharge to the consistency of thin putty and sinearing the same over the point of leakage, afterwards "serving" it with a bandage of waxed light thread, or failing the latter, a narrow tape previously steeped in boiled oil. A couple of strands of light copper wire then applied will prevent the bandage slackening back.

One of the special plugs used for stopping leaks should be kept by every motorist whose car is fitted with a honeycomb radiator. A very simple contrivance consists of two squares of thin plate aluminum with sheet rubber attached to one side. On the side carrying the sheet rubber there is a little lug, and one end of a spiral spring is hooked on to one of the plugs. With the plug is supplied a jointed wire about 6 inches long. This is passed through the defective tube in the radiator, and the other end of the spring is looped on to a hook in the wire. The spring is then pulled through the tube by the aid of the wire until the end protrudes at the far side of the radiator when the second plug is hooked on to the other side of the spring. The tension of the spring keeps the rubber faces tight up against the faulty section of the radiator, and so effectively stops the leak. The whole arrangement is simple and can be fitted by anybody.

To minimize the risk of pipes and radiators getting choked

with a deposit of foreign matter, some owners use a wide-spouted water can, with a piece of Turkish bath towel tightly folded and jammed into the base of the spout. This forms an effective filter.

(e) **The Fan**—If the belt slips the fan will not revolve fast enough to keep the water adequately cool. Clean periodically, dress with castor oil, and keep well adjusted.

(f) **The Water Jacket**—A leakage or crack in the water jacket is not uncommon, and will affect its efficiency. The best method of dealing with same is to have the casting repaired by brazing or, preferably, autogeneous welding.

The water jackets should be examined periodically to see if any furring-up or corrosion has taken place. They might be well hosed out with a hose pipe, and a powerful stream of water sent through until it comes out quite clear and free from rust deposit. This should be sent through from all the inlets and in the opposite direction through the outlets, the position of the cylinders being constantly altered so as to insure the water thoroughly swilling out all round the valve ports and corners. In extreme cases of furring, it may be advisable to boil the cylinder for some time in strong soda-water. A gentle tapping on the outside of the cylinder with a hammer, but not so heavily as to cause any damage, will then often result in the "sediment" on the walls coming away. In some cylinders the water jackets can be got at from the top by taking off the cover completely, and in this case, a steel instrument, or a rod with a hardened end, may be used to detach any incrustation which may have formed round the walls. Care must be taken to insure that all the small pieces and loose grit and sediment are thoroughly swilled out and cleaned away, otherwise they may cause obstruction in the pump and circulating system, even to the extent of actually damaging the pump.

WHEELS (ROAD).

Symptoms: Wheels out of alignment.—Looseness or creak in spokes.—Faulty steering.—Tires scored transversely.

Causes: Bent car axle, stub axle on which wheels revolve, steering link, or steering arms.—Spoke broken, cracked, shrunk, decayed, loose in hub.—Bearings worn or loose.—Hub shaky.—Springs moving fore and aft on axle.—Axle moving endways on springs.

If the wheels incline outward at the top it will generally be found that the axle is bent. This trouble is dealt with comprehensively in the discussion under "Bent Axle." If they incline inward at the top the bearings want adjusting. Failure in the wheels themselves is a much more serious matter, for they are apt to collapse at a corner or from a side-slip without the slightest warning. For this reason they should be subjected to frequent and close inspection. Incipient cracks and splits can generally be seen, but internal weaknesses, shaky hubs, loose spokes, and defective or shrunken wood are very difficult to locate. The wheels should be jacked up and pulled and pushed violently backward and forward. If there is lateral movement between the rims and hubs, or anything of the nature of a creak, it may be taken for granted that something is wrong. The tightness of the spokes can be tested by tapping them with a spanner or such like. The different note between those that are sound and those that are not will be at once apparent. The best plan under such circumstances is to take the wheels at once to a first-class coachbuilder who is accustomed to motor car work and have them examined. If there is any doubt whatever as to the repair proving a good job it is far better to order new wheels. It is simply suicidal to continue using faulty ones.

Trouble with wire wheels is very easy to locate. A broken or loose spoke is the most usual failing, and the immediate effect is to make the rim untrue. The wheel can easily be trued by fitting a new spoke, or re-tensioning the loose ones. It is very rare for a faulty wire wheel to collapse, as a wooden wheel will, without definite warning.

Needless to say, the bearings should frequently be examined for wear. (See Bearings.)

It is essential that the wheels should be in correct alignment, or the steering will prove defective, and the tires wear

quickly. Sometimes, especially where chains are used, the back wheels will be put out of alignment with the front by incorrect adjustment of the chains through the medium of the radius rods. Correct adjustment is fully treated under Chains. This will cause the car to run sideways and put considerable strain on tires, springs, and steering mechanism. It can be remedied by a readjustment of the radius rods, or, as they are sometimes termed, chain stays. In the case of the Daimler car, with aluminum chain cases, there is an eccentric adjustment. It is best to ascertain that the back axle is square with the frame by careful measurement to the front of the chassis on each side, and determining that the distances are the same.

Another difficulty which sometimes arises, and which puts the back and front pairs of wheels out of alignment with each other, is the slipping sideways of the springs on the axle or axles. This cannot happen in those cases, found in the best practice, where spring plates are forged solid with the axle and the spring straps pass through holes in the plates. But sometimes the spring plates are strapped to the square axle by means of the same straps which hold the springs. In such cases, on the nuts becoming loose or the straps stretched, the springs may move bodily with the straps and plates along the axle, thus putting the wheels out of alignment.

The distance they have moved is generally indicated by the rubbing away of the paint and varnish. The nuts should be slightly untightened, and the spring, plate, and straps driven back into position by means of a hard wood block and a heavy hammer. The nuts should then be carefully tightened up and locked. If the trouble continues to occur, a simple remedy is to drill a couple of quarter-inch holes in the top of the solid axle adjacent to the sides of the plates—one on each side—and drive in a tapered steel pin which will prevent the end movement of the spring plate on the axle.

Sometimes trouble arises due to the spring moving fore-and-aft on the axle or spring plate. This is also due to the

straps stretching, or the nuts slacking back, or to a violent blow, as in an end-on collision.

In such cases the nuts should be slacked back and the axle driven, by means of a hard wood block and a heavy hammer, in the required direction, and then tightened up again. During the operation the car should be on a level place and unladen. The distances from the front dumb-iron or the front spring hanger to the axle should be measured on each side and should coincide.

A bent axle, as is suggested under Bent Axle hereinbefore, may put them out of alignment, but it is usually due to the steering arms or steering link connecting them getting bent and shortened from contact with road obstacles. Very often by standing some distance behind or before the car, preferably when it is in motion, the defect can be distinguished by the eye. The best test, however, is to get a straight edge and check the alignment of the back and front wheels as regards each other. This can best be done with the tires deflated so that the straight edge rests against the rim of the wheel and always parallel with the ground. The next point to make sure of is whether the two front wheels are absolutely parallel to each other. With a tape measure check the distance from rim edge to rim edge of the front portion of the two wheels, and then to the back portions. This test will only give true results if carried out when the steering wheels are set for the car to run straight forward. If there is any difference it will prove that the wheels are not parallel. Adjusting the steering link may make matters right, but the trouble may be due to a bent steering arm, in which case it is very likely that it will take some little skill to detect. As already mentioned, a bent axle will affect the alignment. The stub axles, about which the wheels revolve, may also be the cause of the trouble, but it must be borne in mind that in many cars the stub axles are deflected downward to enable dished wheels to be used, so that the distance between the tops of the rims and the bottoms of the rims will not correspond. Should the stub axles be further

bent upward or downward, however, the variation in angle of the two wheels will easily be seen. If at all possible, the work should be placed in the hands of an expert.

FREEZING OF WATER COOLERS.

Every driver of a water-cooled car who leaves it unprotected for any considerable length of time in zero weather with the engine "dead," is bound to have more or less trouble. So long as the engine is left running, heat enough will be generated to keep the water from freezing, but this is an expensive remedy. When the engine is stopped, as economy dictates, the heat is shut off, the water in the cooler becomes chilled and finally freezes. Then the motorist must thaw it by the application of hot rags, or similar means before he can resume his journey. This is a long, tiresome, and not over-pleasant job, especially on a cold, blustery day.

There are five mixtures which may be used in the water cooler, all of which will effectively prevent freezing. The trouble is, that four of them have to be graduated in strength to meet the degree of cold which they are to overcome, while the fifth, although the cheapest and simplest, and probably fully as effective as the others, is highly destructive to the metal parts of the radiator. These non-freezing agents are: alcohol and water; calcium chloride and water; glycerine and water; alcohol and glycerine; and a solution of sodium chloride, or common salt. These various mixtures are popular among motorists in the order named. The salt solution would stand at the top of the list were it not for its destructive effects.

Alcohol Solution: This is usually preferred because it is clean, does not damage the metal of the waterjackets or radiator, and has no deleterious effect upon the rubber hose connections. The chief drawback to the use of an alcohol solution is that it evaporates quickly and then of course the residue freezes. The only way to guard against this is to test the solution frequently, and keep it at its highest point of efficiency. Cost is an item to be considered and it will be found that

either wood or denatured alcohol, both of which retail at about 25 cents a quart, is as satisfactory as test alcohol, which sells at 80 cents a quart. The capacity of radiators differs, but the average is between three and four gallons.

It is difficult to make any hard and fast rule for the mixing of alcohol and water. Climatic conditions and other things must be taken into consideration, although the freezing point remains always the same. The following table of percentages of alcohol to water will be found satisfactory for the temperatures given, the calculations being based on the Fahrenheit system:

Approximate temperature	Percentage of alcohol to use	Freezing point	Amount of alcohol to use in 3-gal. radiator
20 above	.15	15 above	1 $\frac{1}{2}$ quarts
10 above	.20	5 above	2 $\frac{3}{8}$ quarts
Zero	.30	9 below	3 $\frac{3}{8}$ quarts
10 below	.35	15 below	4 $\frac{1}{8}$ quarts
25 below	.45	28 below	5 $\frac{3}{8}$ quarts

To make clear the meaning of these figures, taking for example the first figures, 15 under the heading of percentage in water, would mean that fifteen parts of alcohol should be mixed with eighty-five parts of water. This would prevent freezing at temperatures as low as 15 degrees above zero. The last figures would mean that forty-five parts of alcohol with fifty-five parts of water would insure the solution against freezing at 28 degrees below zero. In general the 20 per cent solution will be sufficient for all ordinary occasions. In many cases one filling of the radiator with an alcohol solution will last throughout the entire winter; but should any loss of radiator supply occur it should be replaced with equal parts of alcohol and water.

Alcohol and Glycerine: No chemical action follows the mixing of alcohol and glycerine, and if equal parts of these are used an anti-freezing solution that combines the best qualities of both is secured. Since either alcohol or glycerine added to water will lower the freezing point, it has been found that combined they would do the same thing, each in its proportion to the water present. They form no chemical com-

binations, but are merely mechanical mixtures. Assuming that the wood alcohol is to be preferred because it is less liable to choke up the constricted passageway or attack the hose connections, and outside these evils, which are characteristic of a glycerine and water solution, it is a most desirable and substantial mixture; then it is well to consider the advisability of reducing the quantity of glycerine and substituting alcohol instead. By the use of both alcohol and glycerine the total proportion of water can be increased and this is a step in the right direction as the cost is decreased and the stability of the mixture increased. Combinations of alcohol, glycerine and water have given very satisfactory service. The following combinations of half alcohol, half glycerine and water are most popular:

Approximate temperature	Percentage of mixture of equal parts alcohol and glycerine to use	Freezing point	Amount of mixture of equal parts alcohol and glycerine to put in 3-gal. radiator
20 above	.20	15 above	2 $\frac{3}{4}$ quarts
10 above	.25	8 above	3 quarts
Zero	.30	5 below	3 $\frac{3}{4}$ quarts
10 below	.35	15 below	4 $\frac{1}{4}$ quarts
20 below	.45	25 below	5 $\frac{1}{2}$ quarts

One thing in favor of this combination is that it lasts longer than alcohol alone as it does not evaporate readily, and the cost is therefore materially reduced, despite the fact that glycerine costs \$1 a quart.

Glycerine: There is much to be said for and against this preparation as a non-freezing agent when used in its crude form. It does not evaporate and this point is in its favor, as, after the solution has been made up, it will not need further attention. This is in theory, of course; in practice it will be found that frequent tests of the solution are necessary to keep it in effective condition. Glycerine is an effective cooling agent and as it will not crystalize in the water-jackets it is preferable in this respect to calcium chloride. As with the other preparations, there are several solutions of glycerine and water for different temperatures, which are as follows:

Approximate temperature	Percentage of glycerine to use	Freezing point	Amount of glycerine to use in 3-gal. radiator
20 above	.30	15 above	3 $\frac{3}{8}$ quarts
10 above	.40	5 above	4 $\frac{1}{2}$ quarts
Zero	.50	2 below	6 quarts
10 below	.60	12 below	7 $\frac{1}{8}$ quarts

These solutions have been known to work very well indeed, although it is true that glycerine does affect the rubber hose connections but not so rapidly as to become over-troublesome. In using the glycerine solution care should be taken to thoroughly cleanse the jackets of any residue of crystals from calcium solutions if these have been previously used, as this residue will thicken and clog the glycerine solution and render it partially ineffective. Solutions of glycerine will thicken up when subject to low temperature but will not solidify, and where there is no solidification, there is no disruption of the piping of the radiator or of the jackets of the cylinders. The slush formation of a glycerine solution passes through a water pump with apparent ease, and as this is probably the most constricted point in the system, the circulation is not noticeably impaired. If a system gets hot with a solution of this kind it is the water that boils off and to replace it is all that has to be done, for about three months at a time. Should the solution, after a time, lose all semblance of its original balance, to start over again with a new solution is the wisest course to follow if one would be on the safe side.

Calcium Chloride: This is probably one of the most effective, and, aside from common salt, cheapest of non-freezing materials. It is essential, however, that a chemically pure article be used if an excessive corroding and destruction of the metal with which it comes into contact is to be avoided. The crude calcium chloride may be had as low as 8 cents a pound, but in the end it is much more expensive and unsatisfactory than the pure article which costs 25 cents or more. It has been proven that a solution made by adding 15 pounds of pure calcium chloride to the three gallons of water in the radiator will prevent freezing, even if the temperature falls to 39 below zero. It is probable that for ordinary winter condi-

tions anywhere in the temperate part of the United States three pounds per gallon will be ample. In this connection Motor Age says:

"The best way is to make what is called a saturated solution, then add water to it until the required mixture is obtained. To make a saturated solution, mix with a quantity of water, warmed to 60 degrees Fahrenheit, all the calcium chloride the water will dissolve. If chemically pure calcium chloride is used no trouble will result, but chloride of lime, CaOCl_2 , often sold as pure calcium chloride, should not be used. It has been advised that a handful of lime be added to this solution to

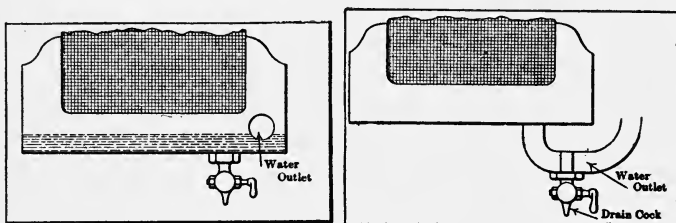

Two Forms of Radiator Drainers.

render it alkaline. This is done to prevent an acidic action of the solution on the metals and its consequent setting up of electrolytic action."

One great trouble with this agent is that it is apt to crystallize in the water jacket, and the danger of this is obvious.

Sodium Chloride: A solution of common salt is the cheapest of all non-freezers, and is effective down to the zero mark. As radiators are expensive, anything which hastens their destruction is objectionable, and this is what salt does. It sets up an electrolytic action which seriously affects the metal and in time destroys it completely. Still, its use may be advocated in an emergency, as when a motorist is caught out in a freezing snap and cannot get alcohol or glycerine. But, in a case of this kind the radiator should be washed out thoroughly immediately on return to the garage, and allowed to dry before it is refilled. Look it over closely before putting in a new

supply of water and if any white spots are discernible give it another washing.

Just a word of caution: Unless your garage is warmed, don't let plain water stand in the radiator in cold weather. If you are not using some non-freezing compound, drain the water off thoroughly every time the machine is housed.

STARTING ON THE SWITCH.

It is the ambition of every motorist to be able to start his car without cranking. In the one- and two-cylinder machines it might as well be understood at the start that this is an

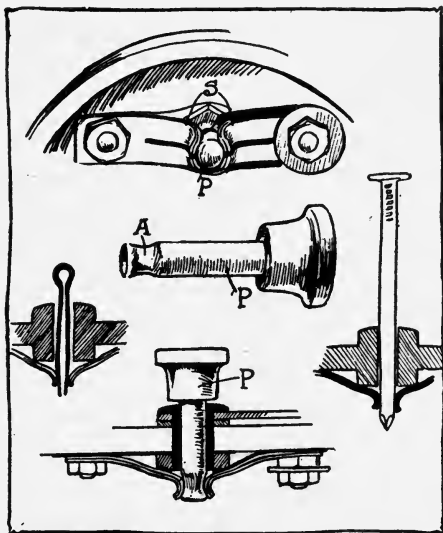

Plug Substitutes for Ignition Switch.

impossibility. "They are not built that way." It is not always possible in the four-cylinder cars, and sometimes even the six-cylinder outfits refuse to respond to the switch. There is less danger, however, of a balk with six cylinders than with four, as the greater the number of cylinders, the more chance there is that at least one of them will be in position to catch the spark.

Where the Trouble Lies: Assuming the motor is a four-cylinder, four-cycle form, we first determine the positions the pistons will assume when the spark is interrupted. Taking the cylinders in firing order, we find that No. 1 is filled with explosive mixture, and the piston is partly down in what would correspond to the expansion stroke had the charge been fired. No. 2 cylinder, with a crank opposite that of No. 1, is also filled with explosive gas and the piston is part way up in its compression stroke. These cylinders may be considered gas tight as the valves are closed. Cylinder No. 3 is being filled

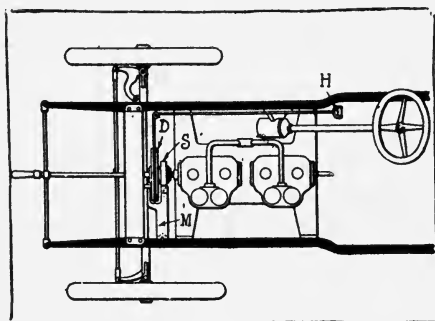

Starting Motor from Driver's Seat.

with gas from the carbureter as the piston is going down for the suction stroke and the inlet valve is open. No. 4 cylinder is being cleared of its contents, and the exhaust valve is open, the piston going up.

Making analysis, it will be evident two of the four cylinders are open to the atmosphere, because the valves are open and consequently under no pressure, but the other cylinders are closed and each contains the same amount of gas. The pressures in the two closed cylinders will be equal when the pistons are the same distance from the top, and as the cranks of these cylinders are opposite, this condition exists only when the cranks are at right angles to the axis of the cylinders and both pistons practically on the same level. When stopping, if the momentum of the motor is overcome when the cranks are at

any other position, the greater pressure in one cylinder will cause the motor to oscillate back and forth until it loses motion close to the position of equilibrium mentioned. This deduction is made, assuming that the valves, pistons, etc., are fairly tight and the friction of the engine is not too great.

After the motor has stopped, with the pistons in the positions shown, let us ascertain what the result will be if the switch is thrown to the battery and the ignition circuit completed. If the spark lever is advanced on the segment so the timer makes contact 90 degrees early, the gas in the cylinder under compression, will explode and the motor will turn backward. Close to the bottom of the piston stroke, the burnt gas will be released by the opening of the inlet valve instead of the exhaust, and a "puff back" through the vaporizer will result. If sufficient start had been given the motor it might fire three or four times, running backward. On the other hand, if the time is retarded to the point where the spark will take place in the cylinder, whose piston is half way down its stroke, for example, cylinder No. 1, the resulting expansion will turn the engine over; the following piston, that in cylinder 2, will be carried to the top of its compression stroke and fired, and the cycle will be repeated through the remaining two cylinders. As soon as the engine is started the spark would be advanced to the running position.

The First Essential: It will be evident the first essential is that the spark be made in the cylinder which is the next to fire, even after the piston has gone part of the way on the down stroke, corresponding to the movement produced by expansion of the exploded charge under normal running conditions. A condition equally important is that the mixture contained in the cylinder be of such proportions as to fire with sufficient force to throw the motor over the following dead center; otherwise it will back before the second piston is in proper position to receive the explosive force.

The conditions that determine the first explosion are good mixture, spark plug position, and timer construction and setting. The carbureter should be first examined to see that a

strong mixture is delivered at low speeds, but in this connection it should be remembered that a mixture too rich will not ignite any better than one that is poor. If allowed to stand for a length of time, any mixture will deteriorate, one reason being stratification of the charge, in which the heavier portions of the gas settle to the bottom. Again where the scavenging action is not positive, a proportion of the burnt gases is retained in the cylinders, and after standing, the fresh gases are diluted by this residuum. If the motor stands too long idle, condensation of the gasolene will take place and the mixture be weakened in proportion.

Position of Spark Plug: The position of the spark plug in the cylinder has some influence in determining the length of time a motor can be left standing and yet be started upon the spark. The pressure of gas in the cylinder at the time of ignition has much to do with the pressure developed, but it should be remembered that when any degree of compression has been retained by the cylinder fired first, the chances are that the cylinder then compressing has also retained an equal amount of gas under the same degree of compression, and the increased resistance partially offsets the effect gained by the gas expanding in the exploding cylinder. It has been learned that the retention of compression is not absolutely essential to starting on the spark, as motors have often been started by a spark after the pet cocks were opened and compression destroyed.

If one cylinder has a leaky valve, or any other defect by which pressure is lost rapidly, it may be the motor will not stop at the normal position, but at almost any point in the revolution. This is a serious condition, for if the piston should stop just before reaching bottom center and with the exhaust valve open, the next explosion will do no good, though in the rare cases where the piston comes to rest about the top of the stroke, the conditions are more favorable to starting. In case of leakage, the cause should be determined and the defect remedied.

CARBON IN CYLINDERS.

Symptoms: Pounding in the cylinders on high gear, preignition, faulty ignition, misfiring, choking of pistons in cylinders, difficulty in getting up speed on high gear.

Probable Cause: Carbon deposits on the piston heads and cylinder walls.

No matter how good the gasolene and oil may be, more or less carbon will be deposited in the cylinders and on the piston heads, and sooner or later will cause trouble. With high grade fuel and lubricant this trouble will be minimized—there will be less of it because there will be less carbon. Excess of fuel and lubricant, or too rich a mixture of gasolene also hastens the deposit. When this becomes so thick as to foul the cylinders to the point of causing preignition, or other trouble, the only thing to do is to clean the cylinders.

How to Clean Cylinders: Turn the engine so that the pistons are on a dead level, and pour through the pet cocks or valve plugs, sufficient kerosene to cover the pistons about one and a half inches and allow it to remain all night. By morning a good quantity will have found its way past the rings into the base chamber. Now take out the exhaust valves and exhaust manifold and turn the engine several times, to allow any remaining kerosene to be expelled; turn the engine so that the piston is in position.

Make or purchase a carbon-removing tool, and through the exhaust valve plug or outlet port, if it is placed conveniently, rake out the carbon, which will be soft.

The next operation is most important, and it is upon the care with which this is done that the success of the whole operation lies. Take the inlet valve plug out, and what carbon it was impossible to reach from the exhaust side should be pushed toward the latter. Wash out with kerosene from the inlet plug to the exhaust by means of a syringe, and finally with a mixture of kerosene and gasolene, half and half, clean out with a fresh rag, but always see that the inlet valve of the cylinder that is being worked upon is closed. It is advisable, when the pet cock is placed in the head of the cylinder, to

remove same and pass a wire down it, as the orifice often becomes clogged with carbon, and although the piston and cylinder are clean the carbon in the cock becomes incandescent and causes preignition. It is preferable to pour the kerosene into the cylinder direct, rather than to take it in by way of the induction pipe.

The base chamber should be emptied and fresh lubricating oil inserted before running the engine, and also insert a small quantity of lubricating oil in the cylinder as well. This can be done through the valve covers, first allowing the piston to go below halfway down, and by this means pour the oil on the walls instead of on the piston head.

Inserting a small quantity of kerosene through the pet cocks after every 300 miles should help to keep the engine clean. Some piston heads are turned rough, and will pick up carbon quickly. When this is so much trouble can be avoided by taking them out and having them polished smooth. Always allow the kerosene to dry off thoroughly before putting in lubricating oil.

NOISE FROM TRANSMISSION GEARS.

Among the causes of noise from transmission gears, which make the vehicle "sing," a French writer mentions the following: "Long shafts, ball-bearings, deformation of gears due to the hardening process and not properly rectified, the tangential speeds of the gears, the shape of the gear teeth, the quality of the metal used in gears, shafts and casings, the shape of the casing, the suspension of the casing in the chassis or subframe. The effect of long shafts may be directly one of vibration or it may be the noise due to the less perfect mesh resulting from the bending of a long shaft. It is claimed that ball-bearings take play much more rapidly than plain parallel bearings, and the writer points to the noiseless motors in which parts are moved with much greater speed than in the transmission, but which, nevertheless, make no sound because the bearings are all plain. He proposes to have the subject investigated by building two cars identical in all respects, ex-

cepting that the bearings in one will be plain and in the other on the ball-bearing plan. It is claimed that the more the transmission casing approaches the cylindrical form the less sound is emitted, and also that a steel casing 'sings' less than one made of light metal. It is suggested to interpose a thin layer of soft metal between the crown of a pinion and the spider, or shaft."

TIMER TROUBLE AND REMEDY.

Many conditions materialize after a motor has been run for a period, which cause irregular action and which are somewhat difficult even for the experienced motorist to locate. A short time ago a well-informed operator of motor cars, who had gained considerable experience by practical observation, had to remedy a case of irregular misfiring decidedly perplexing, and the reason for the erratic action was discovered only by accident. The source of the trouble was the timer. In going over the ignition system while the motor was running, and moving the primary wiring to learn if there were broken connections or imperfect contacts, a slight play or side motion was noticed in the timer. It was observed that when pressed to one side the motor ran regularly. The cause of missing was then concluded to be a poor ground connection between the revolving parts of the timer and the engine proper, owing to the lost motion of the worn parts which included the bushing surrounding the timer shaft and the gears below.

The most logical remedy is to insure a more perfect contact between the revolving portions and the stationary part, having a good metallic connection with the engine. The simplest method of so doing is to make a V spring of steel and attach it to the center of the commutator cover, so that the lower blade will bear upon the end of the upright shaft which carries the revolving distributing brush, which makes contact with the collecting segments around the timer periphery. A wire is then led from the same screw that holds the spring in place on the cover, to the commutator standard, or to a nut holding

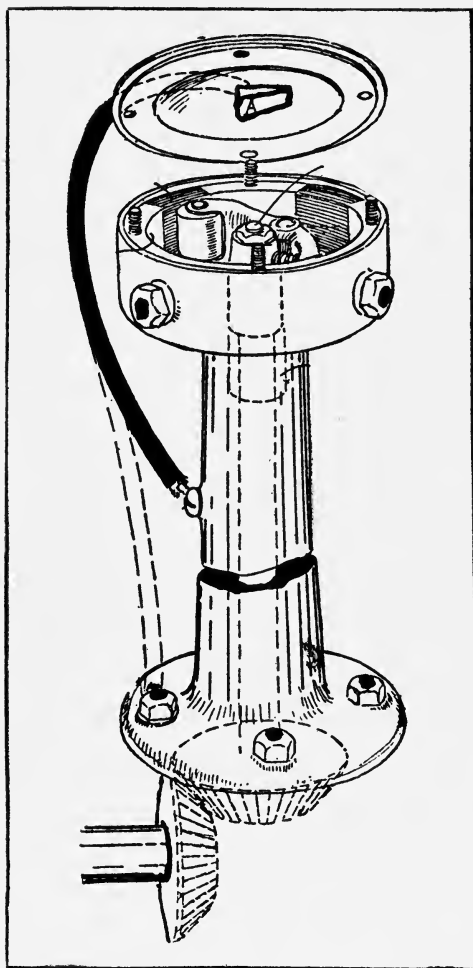

Handy Method of Reinforcing Timer Contact:

it in place at the base, or to any other point having a good metallic connection with the engine.

Another Trouble.—There is another cause of trouble in an old motor that is often overlooked. As the surfaces of the fiber insulating ring on the inside of a commutator or timer

wear quicker than the metallic segments, a light cut is often taken off this surface to true it. If too much is taken off, the arm of the lever on the revolving segment, which holds the contact roller at one end and the tension spring at the other, will bear against the hub of the brush member, holding the roller away from the periphery of the ring and contact segments, or at least causing a poor contact and resultant misfiring. The mechanic, knowing that the surfaces are perfectly true and that the timer is in first class condition, is liable to look elsewhere for the trouble, which may not be found without a considerable loss of time. The remedy for such a case is to either bend the lever back a trifle or file a small rounding groove in the hub of the revolving member so that the lever has sufficient clearance, and the spring effort is entirely exerted in keeping the roller in contact with the inner periphery of the fiber ring.

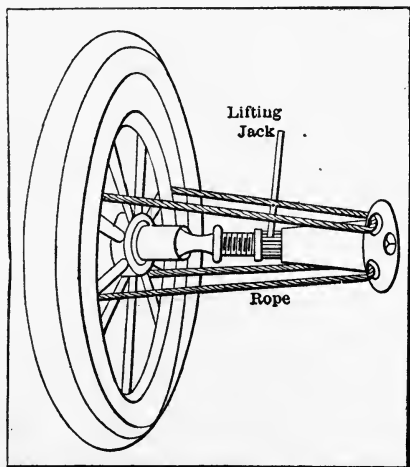

Simple Method of Removing Tight Wheel.

It is frequently the case that wheels and sprockets become so tightly set that it is difficult, if not almost impossible, to remove them without injury. In a case of this kind relief may be had by an ingenious use of an ordinary lifting jack, which every motorist is supposed to carry.

Attach stout ropes to four of the spokes as near the brake drums as possible. Then remove the hub cap and insert a block of hard wood so it will touch the end of the axle. Unscrew the jack so it will be down to its smallest lift, and place the head end against the block of wood. Next pass the ropes through the holes in the base of the jack, or around the base if there are no holes, and make them taut. As you screw up the jack in the ordinary way an even pressure will be exerted which will bring the wheel off without injury, and with little trouble. It is a far better method than attempting to tap the wheel loose with a hammer, which, no matter how carefully done, is pretty sure to mar the paint, if it does not do more serious injury. Exactly the same means may be employed in the removal of sprockets.

TROUBLE WITH VALVE TAPPETS.

Tappets are the push rods which open and close the valve seats. It frequently happens that these rods get out of adjustment, leaving too great a space between their heads and the end of the valve stems. When this occurs there is a noisy, clicking sound which can be only overcome by readjusting the tappets. Generally the space between the adjacent ends of the push rods and valve stems should be between 1-64 or 1-32 inch, sometimes more, but rarely less. Of course the smaller the space the less noise, but sufficient space must be allowed for elongation of the valve stem due to expansion when the motor becomes warm, and for irregularities in the shape of the cam or roller.

When the space is too great there will be a disagreeable sound—not a pound or a knock, but a clicking noise. It may be caused by one tappet, by two, or by all, although it is seldom that all of them are out of order at one time unless they have been neglected.

Locating the Trouble.—For locating the noisy valves in cases of this kind a simple tool, such as is shown at Figure 4, may be used to advantage. This is made from a strip of brass

about 1-16 inch thick and 8 inches long, with one end tapered by laying it on an anvil and pounding it into shape with a hammer. A tool of this kind may be readily slipped under a suspected valve stem as indicated in the center valve in Figure 5, and when the offending valve is found the insertion of the tool will cause the clicking to cease abruptly and the valve to remain quiet until the tool is removed.

The experienced repairman can generally find a tappet that

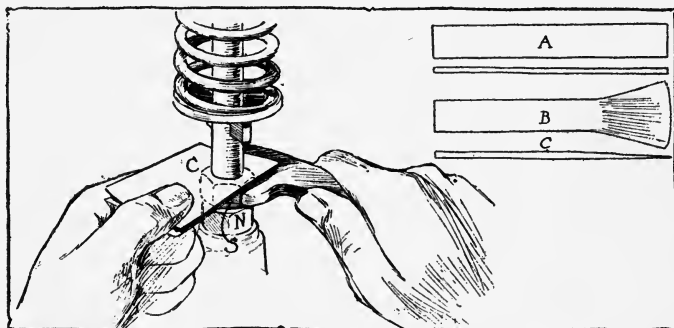

Fig. 4—Tool for Locating Noisy Valve Tappets.

is badly out of order in a very short time by simply working the tappets of each cylinder up against the valve stems and down again with his fingers, while the pistons of the respective cylinders are on their compression strokes, but the novice will find the use of the simple tool described the best.

Adjusting the Valves.—If all the valve stem spacings of a motor are to be examined and adjusted the best method to follow is to turn the motor over by hand until the piston in the first cylinder is about half way up on its compression stroke, at which time both valves of that cylinder should be tightly closed; then examine the space between the stems and push rods. In the absence of a suitable steel gauge for regulating valve space many repairmen use a common business card as shown in Figure 4. The card C is folded once and slipped between the ends of the stem and tappet, the lock-nut

N is loosened, and the stud S is screwed up or outward until it just begins to pinch the card and prevents it from sliding about as readily as at first. The card is then removed and the lock nut tightened.

When both the inlet and exhaust valves have been adjusted in this manner each one should be individually tested with a single thickness of the card to see if the valves remain tightly closed throughout the required period. This is best done by sliding a single thickness of the card back and forth between the ends of the tappet rods and valve stems as the motor is in

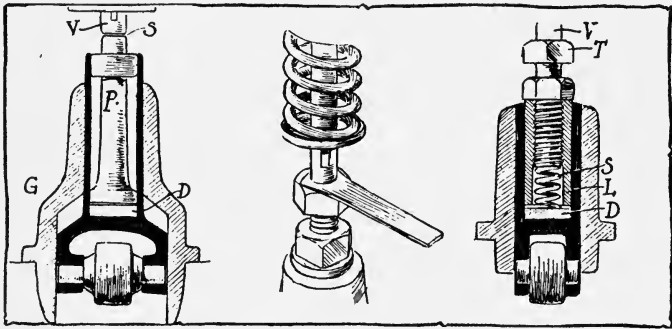

Fig. 5—Various Methods of Adjusting Tappets.

being turned slowly from the closing to the opening points of each valve. The marks on the flywheel may be used to advantage in this operation if accessible, but they are not necessary. One can slide the card under a stem and turn the motor until the card is seized, indicating valve opening, then a little further until it is free again, which marks the closing of the valve; now, by turning still further and continually turning the card about, if the card is not seized before the regular time for the valve to open, according to either the position of the piston or crank-handle, the adjustment is about right, but if the card is prematurely seized the space is not sufficient. The valves in each cylinder should be adjusted in the same manner.

Other Forms of Adjustment.—In Figure 5 a sectional view of the Oldsmobile valve tappet is given. To all outward

appearance this tappet is not adjustable, but if adjustment of the space S is desired one has only to raise the valve stem V, remove the tappet and casing G from the motor, take out the plunger P, and replace the disk D with one of a thicker or thinner size. These disks are furnished in thicknesses varying by thousandths of an inch.

Another type of adjustable tappet that has given trouble to the novice is that of the Inter-State motor shown in the last valve in Figure 5. The adjustable feature of this tappet is quite conventional but to reduce the tappet noise to the minimum all space between the valve stem V and the tappet stud T is eliminated by the spring S which holds the stud T against the end of the stem V; the required space in this case being between the lower end of the sleeve L and a fiber disk D, where the sound is considerably muffled.

FLOODING OF FLOAT CHAMBER.

Symptoms: Car runs smoothly, but clutch slips in ascending hill; after halt engine does not respond to cranking.

Cause: Too much gasoline in float chamber.

The cause probably is that the adjustment of the level is incorrect, allowing too much gasoline to get into the float chamber; not sufficient, to cause an overflow when the car is standing still, but as soon as it is inclined and allowed to stand still on an upward grade it overflows the jet, causing the flooding.

The layback of the needle valve while the car is standing still on an up-grade will cause an overflow at the jet if the seat of the needle is not a perfect fit on its seat or any small impurity finds its way underneath the same, rolling back owing to the inclined plane of the car.

The effect of flooding will not be noticed as long as the car keeps going, as the extra amount of gasoline will be used up by the extra work the motor is called upon to perform; in fact, it will improve the running of some cars to place the float chamber in front of the jet. In most cases opening the petcock beneath the carbureter and draining off some of the sur-

plus fuel, and then closing the cock is all that is required. A few moments later work the crank vigorously and the motor will almost invariably get into action.

LOCATING A "KNOCK."

It is one thing to know that your machine is "knocking," and to be able to remedy the difficulty when you are certain where it is. Definite locating of the cause of the "knock," however, is an entirely different thing. The man who is not schooled in this particular line may hunt for hours without being able to locate the trouble, while one who has the "know how," will be able to put his hand on the defective part without much trouble or delay. The causes of "knocks," and the various means of overcoming them are treated at length on pages 95-98 of this book, so there is no necessity of again taking up this feature of the subject. The only thing of interest to be now considered is the means of locating the "knock."

Locating the Trouble.—There is a wide difference between knocking and pounding. The latter invariably occurs within the cylinder, while "knocks" usually occur in connection with the crankcase mechanism. Any man of ordinary sense should be able to distinguish between the two by the difference in sound, this difference being well explained by the terms used to describe the two noises—one is a "knock;" the other is a "pound," although they are misused interchangeably.

Assuming that the main bearings of the crankshaft are properly adjusted, the only other possible cause for the trouble that presents itself is that the attachment of the crankcase to the cross-members of the frame, is insecure. First assure yourself whether the knock really comes from the front end or the rear end of the crankcase. This may be done by loosening the ignition cables on the plugs of the first and fourth cylinders, then, while the motor is running, disconnect and connect each of them several times; if the knock is at the front end there will be a decided knock every time connection is

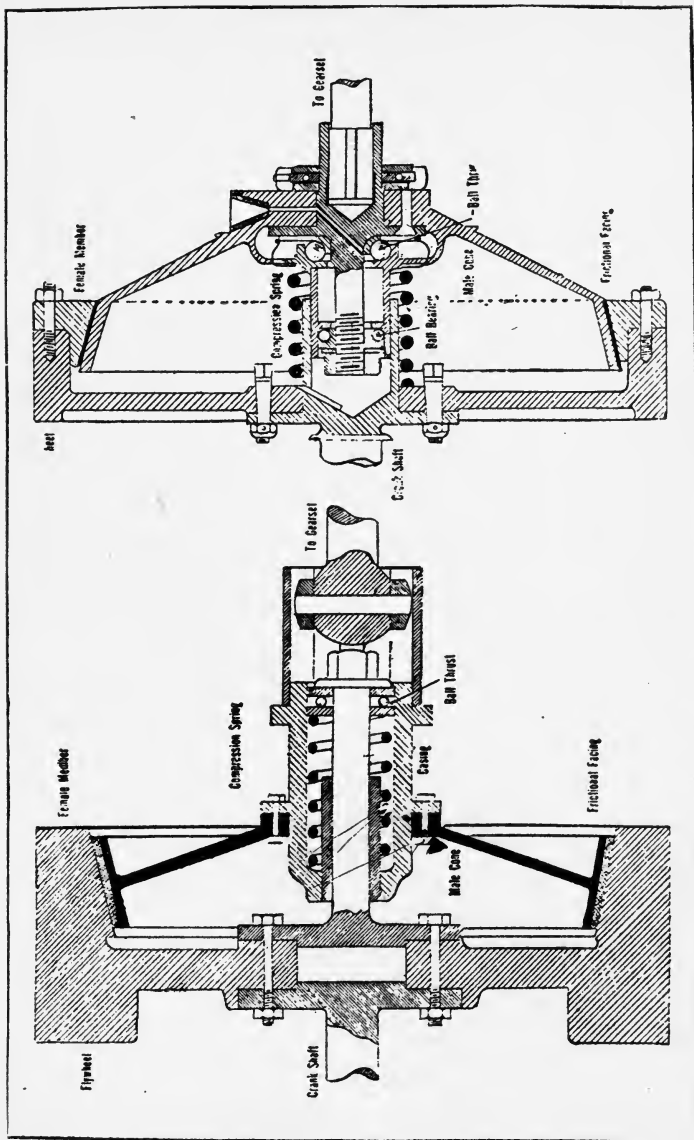

Typical Cone Clutches in Transmission Systems.

made with the plug of the front cylinder, and if the knock occurs when connection is made with the plug of the rear cylinder then the rear end attachment is at fault. If, however, there should be a knock at both ends then, perhaps, both ends will require tightening up. To tighten these connections lower the mud-pan, and take off the inspection plates at the bottom of the crank case; access may then be had to the cottered and castellated nuts which secure the crankcase to the cross members of the frame. Remove the cotter keys, tighten the nuts which are loose, and the trouble will be eliminated.

ENGINE HARD TO START.

There are many reasons why a gasolene engine is slow in responding to efforts to start it. There are few drivers but what have trouble in this respect, and but few who can locate the trouble except by chance. Most of the complaints are about as follows:

“We can only get a few shots from our engine, it will then die down and stop; sometimes we see a dense smoke coming from the exhaust as a result of these few shots; but the engine will not keep a-going long enough to gain any speed.”

The Blacksmith and Wheelwright says that the smoke complained of indicates one of two things: either an over-supply of gasolene or an excess of lubricating oil in the combustion chamber. The latter is not so likely to occur in the beginning of a run or in starting the engine as after the engine has been running for a while.

The former is more likely to occur when starting the engine than later; therefore, it is tolerably safe to conclude that the engine is drowned with gasolene. That is, there is too much gasolene in the combustion chamber for the air taken in, causing too rich a mixture, which is hard to ignite, and if ignited at all will cause incomplete combustion and a light expansion, resulting in very little power from the explosion.

Consequently, the engine cannot gain speed from the few impulses nor completely consume the fuel in the ignition or

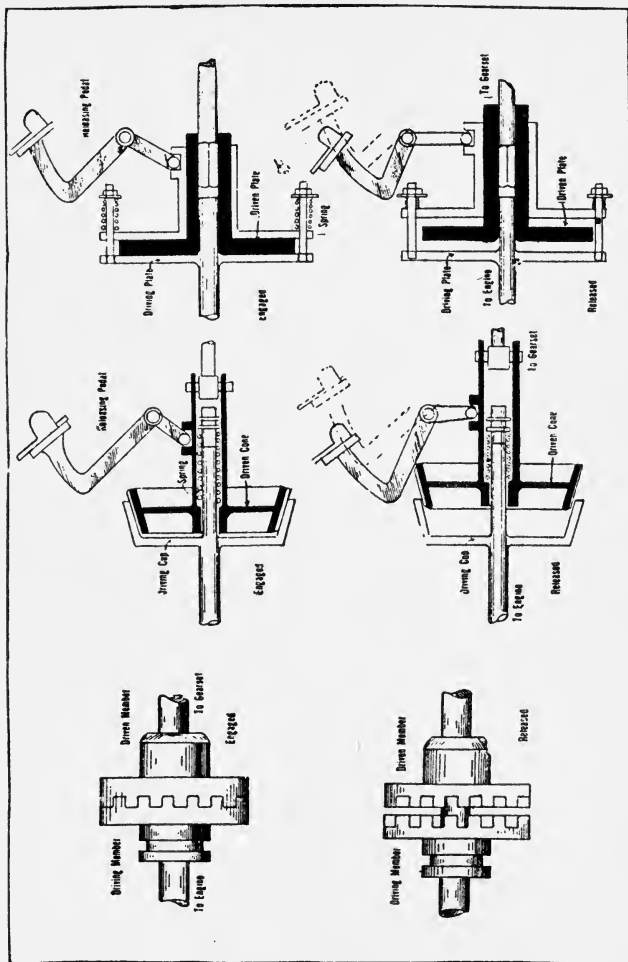

Operation of Positive Cone and Clutches.

combustion chamber. Part of it goes out in smoke instead of being burned up clean, and, as a rule, the operator in his anxiety to get started turns on more fuel as soon as the first shot is taken, which only aggravates the already drowned condition. Adds "insult to injury," as it were.

In many instances it is found necessary to keep the needle valve tightly closed for some time and coax the engine a few

shots at a time until the surplus fuel in the cylinder is sufficiently consumed to begin taking its ignitions and impulses regularly.

When there is quite a quantity of liquid gasolene in the combustion chamber it will not all burn up at one ignition, nor at half a dozen for that matter. It will, in connection with the burned gases remaining in the cylinder from previous charge, choke the intended succeeding ignition entirely and prevent it. Consequently, it may result in only one impulse and stop, or after missing several, catch another, then miss one or more, then catch again, and so on until finally enough of the fuel is consumed to cause a better mixture and a more effective combustion.

When all the fuel that has been flooded into the cylinder is used, then turning on a little from the needle valve usually drives the engine up to full speed and no more trouble is experienced until the next start. Sometimes this trouble is caused by opening the needle point too freely, or there may be a leak through the carbureter mechanism, or, if float carbureter is in use, the float may fail to shut off the supply and allow flooding.

Other Causes.—On the same subject Gas Power offers the following suggestions: The old saw about “no gasolene in the supply tank,” and “the electric spark circuit cut out,” should fool no operator in this wide-awake gasolene engine age. But they do.

First of all if a battery is used to supply the ignition current let us enquire if it is getting weak when ignitions fail to occur, and why it is weak. It may be on account of age, long usage, evaporation of liquid within the cell, internal short circuit, or too great a drain because of almost continual contact of the circuit breaker. If a magneto is used to supply the current and ignition does not occur regularly we may look for a worn-out brush, or a brush which is stuck in the holder and does not touch or ride the commutator at all; or the armature may not revolve, or so slowly that no current is generated. In one instance an armature would not revolve and on investiga-

tion it was found that the shaft was stuck in its bearing because of some fine cuttings that had lodged there. A little dressing and cleaning of the box corrected the trouble in short order. Then the contact points in some magnetos may get loose, or the winding of the armature may get damaged, or the wire carrying the current to the engine may get short circuited and take the current to places other than the igniter points.

Timing Device Troubles.—The timing device may be out of adjustment, or the igniter points, if of the contact kind on the inside of the ignition chamber, may have become loose and fail to make contact. The insulation of the spark plug may be broken, allowing a short circuit. The spark coil may be wet or damp, also causing a short circuit. There may be a loose set screw or thumb nut on some of the binding posts that are supposed to hold the ends of the wire onto the engine, the spark coil, the batteries, or the switch. Next to ignition we must think of the carbureter and its mechanism, and find out whether the mixture is too rich or too weak.

One of the very common causes of failure to start is the flooding of the carbureter. The operator, in his anxiety to get a good start, flushes the mixer so that the first inhalation carries into the cylinder a "slobber" of gasolene which is unatomized and therefore not serviceable.

Then we have leaky valves, cracked piston rings, defective spark plugs, faulty packing, and water in the cylinders, any one of which will cause difficulty in starting.

ENGINE STOPS SUDDENLY.

When a motor stops unexpectedly it is well to diagnose the symptoms immediately proceeding the final "kick." If the motor quits working without advance warning, begin by overhauling the ignition outfit to ascertain whether the spark is ample. Take the wire from the spark screw and wipe the end of the wire on the frame or bearings. If there is no spark, or a feeble one, the trouble is very likely in the battery or wiring.

Open the locker which contains the battery and spark coil, and go over the binders carefully in search of some part which has been shaken loose by vibration. If everything is tight and in good order next feel of the wiring to discover a short circuit caused by breakage or a chafing through of the insulation. If there is nothing wrong here try the spark again. Failing to locate the trouble by these means put an ammeter to the terminals of the battery box. The chances are that the cells may be exhausted.

If the cells are dead get a jar of salammoniac solution and, having punched a few holes in the cells, immerse them in the solution. Three minutes of soaking will usually restore enough life to the cells to put the battery in working order again.

WHEN THE LIGHTS "KINK."

When the lights flicker, and almost go out at times it may be, and doubtless is, caused by water getting into the tubing. Of this A. W. Strawman, of Anamosa, Iowa, writes as follows:

"I recently came across a garage owner who had been troubled very much this way and here is how he provided a remedy: He had a tinner make a tin cup about $1\frac{1}{2}$ inches in diameter and about 2 inches in height. Have two openings about $\frac{1}{2}$ inch in length the right size to fit your tubing; attached to the sides as close as possible to the top, each opposite the other. Be sure your cup will be airtight when attached. You can tell before hand by holding your finger over one end and blowing in the other end. All you have to do to attach the cup is to cut your tubing in two and slip the ends on. To empty, pull ends off and turn the cup upside down. This owner had his cup attached close to the generator, just close enough so that the weight of the cup would rest on the running board. I don't think it is really necessary that the cup should rest on the running board if your tubing fits tight and you empty it each night after using the lights. This man said it was surprising how much water would collect in the cup in one night and said that his lights had not troubled him a particle since."

DETECTING A SHORT CIRCUIT.

Where a short circuit is suspected it may often be detected by testing the ignition in the dark, as a spark will be noticed passing from the defective point. The "short" is most liable

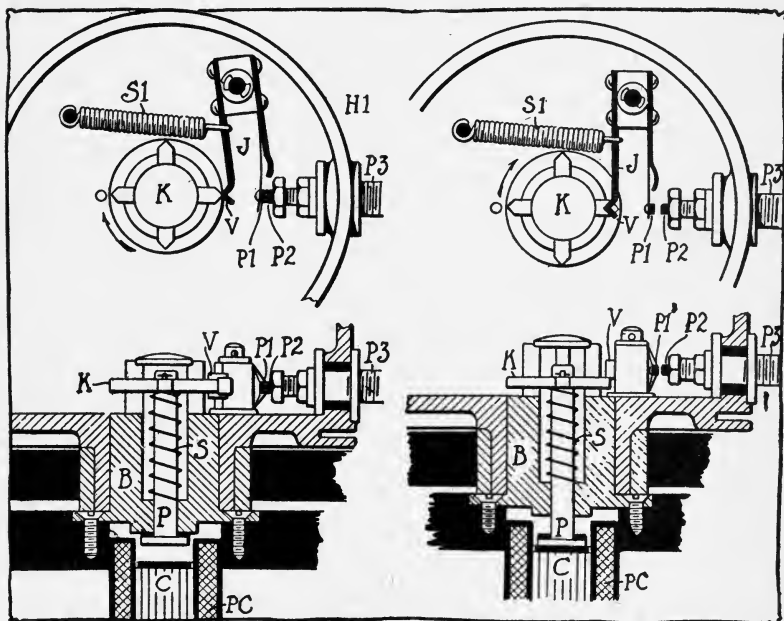

Mechanism of the B. & S. Breaker.

The left-hand illustration shows cam K in contact with blade V, and platinum points P₁ and P₂ together. The plunger P is in the "up" position. In the right-hand illustration the cam K has fallen away from the blade V, thereby allowing the platinum points P₁ and P₂ to separate.

to occur in the high-tension circuit, in connection with the wire leading from the coil to the sparking plug. The trouble should be looked for while the wire is in the position it generally occupies on the car, as the mere act of moving it in order to make the test may prevent temporarily the recurrence of the short circuit, and thus mislead the operator.

Things to Avoid.—Never purchase cheap insulating wire.

A few discharges of the battery will more than make up the difference between the cost of cheap and good quality wire. When the wire becomes chafed the worn parts should be rebound with insulating tape and precaution taken to prevent further rubbing. When new wire can be obtained replace the worn part. If this is not to be had slipping a length of rubber tubing over the damaged section will give protection.

Oil rots insulation and it is therefore essential that wires should be kept free from oil so as to lessen the liability of a short circuit. Should a leak occur and the insulation appear sound, there may be a breakage in the wire itself. Pass the wire through the fingers, giving it a bending motion. If a break exists it will be readily felt. Should it escape detection by this means try a voltmeter on the primary wire by forming a circuit of the battery, wire and voltmeter, giving the wire a slight twisting during the test.

Repairing of Break.—If there is current in the battery, but none can be detected through the wire by the voltmeter, it is evident there is a break. If new wire is not at hand the break may be repaired by slitting the insulation lengthwise over the break, and peeling it back for about an inch on each side of the break. Then twist the bared ends of the wire together, turn the insulation back over the joint, and bind carefully with insulating tape. This will last, and do good service, until new wire can be obtained and the defective part replaced.

Proper Lubrication Important.

The trend of automobile design in latter days has been in the direction of elimination of plain bearings, not so much because the bearings failed to work, but for the reason that there is a certain sturdy reliability in connection with types of ball and roller bearings which is not to be imitated in the absence of their use. It is commonly supposed that ball and roller bearings are used for their anti-friction qualities, thus promising an increase in the mechanical efficiency of the machine.

It is true that the mechanical efficiency of the machine is in-

creased if ball or roller bearings are used, but the advantages thus afforded are scarcely worth mentioning in the light of the fact that a continued supply of suitable lubricating medium is difficult to afford and plain bearings will not lend themselves to the process with the same certainty that follows the use of anti-friction types of bearings.

Lessons Learned by Experience.

In the earlier days of the automobile the question of lubrication assumed a position of undue importance, through the use of inferior lubricants, in many cases due to the lack of knowledge of autoists on the one hand and lack of experience in the automobile industry on the part of the manufacturers of lubricants. It was for autoists to learn that the lubricants to be used in work of this character could not be too good, nor of a promiscuous selection.

It was also for the makers of lubricants to learn that they could not afford to blindly dole out cheap oil for use in automobiles at the instance of autoists who failed to appreciate the needs of the occasion. In the meantime, it went a long way in the direction of good success when the builders of automobiles made up their minds to supply the means by which lubricating materials could be used advantageously in the bearings to be maintained in working order.

Kind of Oil Required.

Unctuousness is the prime property. If the oil will not afford a slippery surface it is of no value. Anything in oil that supplants unctuousness is detrimental, since it displaces the very property for which oil is used, primarily; soapstone, chalk, talcum, or any other (so-called) body maker, therefore, an adulterant that can have no place in an honest lubricating medium.

Body, next to unctuousness, is of importance, since oil has a duty to perform aside from furnishing a slippery surface. The metals must not be allowed to come in contact with each other, and the requisite body must be there to enable the oil to sus-

tain the pressure. Mobility is also a property that should be well regulated, in view of the arduousness of the service, and, also, the mobility should be constant. If the oil lacks mobility it will flow sluggishly, and may not be able to flow freely into the surfaces to be lubricated.

Acid a Costly Evil.

Mobility should not be much affected by temperature changes. Acidity in lubricants is the banè that leads to grief. The costly ball and roller bearings are ruined by acid, and in plain bearings the polished surfaces of the spindles and journals are ruined. Acidity may be due to a faulty process, or it may be the product of reaction in the materials used. Heat and light in the presence of atmosphere seem to be all that is necessary to render the average "animal fat" acid in its reaction within a short while after it is compounded.

A residue after combustion is very undesirable; nor does it matter if the residue is carbon alone or carbon and other ash producing elements. Cylinder oil is ultimately burned and the products of combustion should be gases, not solid non-combustibles. In this connection it may be mentioned that all cylinder oils should be filtered. Filtration materially reduces free carbon, and a filtered oil will always deposit less carbon than an unfiltered oil. Filtered oils may be distinguished by their lighter, clearer colors.

Things to Be Avoided.

A good lubricant with a bad color is superior to a bad lubricant with a good color, but the fact remains that any given oil will be improved if it is filtered. In other words, a bad oil can be made better by filtering, and a good oil can be made better by filtering. In each case the color is made lighter.

Jelly-forming constituents are much to be avoided. What is wanted, then, are unctuousness to the maximum, body regulated to suit the conditions and a constant mobility unaffected by temperature. Solid lubricants should only differ in body; they should not lack unctuousness, nor should they change mo-

bility under temperature changes. What we do not want are acidity and residue. Pure mineral lubricants seem to be the right products in automobile work and, fortunately, there are producers of honesty and skill catering to the automobile trade.

The automobiles of today are less noisy and lower in cost of maintenance because grease cups are used in great profusion, where once a hole was drilled and dirt was free to enter, there to mix with an occasional drop of oil, to make abrasions that soon increase the lost motion and the rattle.

Care in Using Lubricants.

If it is important to provide lubricants of a satisfactory quality in automobile work, it is equally important to provide the means for utilization of the same. In former times it was the custom to oil the crankshaft bearings of the motor, thrust grease in the transmission gearset, and daub oil over suspicious looking surfaces, hoping thereby to accomplish the important purpose at small expense of labor.

Then it was not unusual to observe a multiplicity of little holes, which punctured the castings serving for journal boxes, as bearings for the linkage members; walking beams on the motor valve motions, and in fact, pretty much everything outside of the crankshaft. The little holes were not protected from mud accumulations, and the addition of a drop of oil on odd occasions served to form the gritty paste which accounted for the rattle that crept into automobiles at what is now regarded as an urgent invitation.

Automatic Use of Oil.

At the present time it is the custom to afford a good mechanical means by which oil or grease is used at every spot, the result of relative motion. Besides the means by which oil or grease is transferred to the bearing surfaces, means are provided by which foreign substances are excluded.

It is also well understood that grease creeping out from the bearing surfaces is a sign that dirt is not creeping in, and so

it is the custom to supply oil in sufficient quantities continuously, not only to afford the desired slippery surfaces, but to prevent the influx of foreign substances.

Office of the Grease Cup.

In former times the utilization of grease cups was but sparing, whereas today each little bearing which cannot be easily reached by oil from the main supply is fitted out with a grease cup, the construction of which is such that grease in the right amount is supplied to the bearings continuously, and the mechanical construction of grease cups is such that the covers will stay on and the pressure will remain as desired, despite the road inequalities and the vibrations they engender.

If it is true that the little bearings are cared for by means of grease cups, it is equally a fact that the universal joints are either packed in grease or are fed with oil continuously through a pipe receiving its supply from a positive oiling system. These positive oiling systems are largely of the force feed type, or they may be what is known as the pressure system. Then there is the scheme utilizing balanced pressures with the oil in a tank cast integral with the crankcase. This idea is being carried out very elaborately in many of the 1911 models. The old crude splash system is retained in point of principle in many cases, but is no longer a crude device.

Efficient Ignition Sources.

When reference is had to ignition sources, the point of view is everything. The time was when the quality of the equipment indicated the absence of careful thought and the details were worked out but rarely, in accordance with the needs of the occasion. Under such conditions, it was no wonder if spark coils fell into some disrepute, and since it is difficult to shake off the reputation whether it is good or bad, it is easy to see how autoists in general cling tenaciously to the idea that spark coils have to be supplemented by some other means of ignition.

Writing on this subject in the *Sportsman and Motorist*, "J. B." says:

During the time when coils were in the constructive stage and before the introduction of features involved in first class work, there were enough spark troubles to make it desirable to introduce a supplementary ignition system. In those days the magneto was so poorly developed that from the point of view of reliability it stood for very little, so it came to pass that the two systems were introduced, hoping that at least one of them would be in working order during the disability of the other. That the reputation for unreliable performances should cling to either the spark-coil systems, or the magneto is not to be explained unless account is taken for the proneness of men to take the future performance for granted as the product of information in relation to the past.

Modern Spark Coils Are Good.

As it is today, spark coils are made under the most rigid specifications as to ability to furnish a spark of the required gap ability, involving the maximum energy required for the purpose. The coils are made in units, thus rendering it possible to replace any one of them for any reason, and while there is something to be said in favor of multiple tremblers on the one hand and master vibrators on the other, it is equally a fact that good results are obtainable either way.

If on the other hand, the question of battery economy is one of special importance under certain conditions, resort may be had to the system by means of which a unit coil is rendered serviceable in the extreme and the energy of the battery is conserved.

It is not uncommon now to observe the use of a magneto in the main, supplemented by a step-up transformer in the absence of a vibrator. In this system, it is the idea to be able to start on the supplementary battery through the good office of the step-up transformer and to maintain running by virtue of the magneto.

Use of Supplementary Battery.

Obviously, the supplementary battery in connection with

the step-up transformer serves in an emergency, if perchance the magneto fails. A system such as this has the virtue of being almost as low priced as that which is obtained if an absolutely first-class multiple coil system is in vogue. On the other hand, this relative cost question will depend upon commercial considerations, which can only be settled as a result of specific investigations for the purpose.

Benefit of Ignition Indicator.

Up to the present time, devices have not been available by means of which an indicator would show the best time of ignition, for a given mixture, considering the speed of rotation. Under the circumstances, it is within the province of the autoist or the chauffeur to determine by experimenting in the light of experience the best position of the spark advance and the most efficient mixture from the carbureter for the purpose.

That the future holds further refinements by the way of suitable indicators, which will show the exact performance under the governing conditions, is not to be denied in view of the present knowledge in relation to this important matter. In the meantime the builders of automobiles are alive to the fact that autoists of discrimination can be intrusted with a general means of controlling the spark and throttle, thus enabling them to realize economical results and the greatest possible flexibility in the operation of the car.

PART 11.

OVERHAULING

.....AND.....

General Repair of Car

Daily overhaul, monthly overhaul, complete overhaul, the engine, the lubrication system, taking down the clutch, reassembling, overhauling, the change speed gear, chains and chain wheels, live axle and differential, the brakes, the steering gear, springs, tires and numerous overhauling, hints and tips.

Overhauling—The term overhauling, strictly applied, would mean a complete examination, adjustment, and repair of every part of a motor car which shows signs of wear. The detection of wear or improper adjustment throughout the whole vehicle would mean the taking apart of practically the entire mechanism. Although this is a job which is, as a rule, beyond the power of the ordinary automobilist, yet some indication of what should be done will help in determining whether his car

has been properly overhauled when put in the hands of competent mechanics. Such general overhauls, which should take place at least at the end of each season, are comprehensively dealt with later, but the daily or weekly overhaul which may be carried out by the owner or driver or chauffeur is of vital importance, if the car is to be kept in running order.

The Daily Overhaul.

We will take first the daily overhaul—that is to say, the daily care of the car when it is in constant use in order that its efficiency for each day's work may be assured. This daily overhaul should not start on the day on which a car is required for work, but on the previous evening, when as soon as the car is brought in for the night, it should be carefully examined, and if it has been driven through mud this should be removed before it dries. Indeed, the sooner mud is removed from the body and chassis work of the car the better will the finish of this be maintained. Mud should on no account be rubbed off the car, otherwise scratching of the coach finish is bound to occur and the smart appearance of the car will be very quickly ruined.

Removing Mud—Mud should never be removed dry. If a car has been driven through mud, and returns home with dry mud on it, on no account should any attempt be made to remove the mud until it has been thoroughly soaked and made soft again.

This can only be efficiently done in two ways. The better method is to use a hose with a good supply of water behind it, but it is most important to note that the water should not be sprayed on to the car with any force. The end of the hose pipe should be open and not have a nozzle. The water should flow freely without rushing, and the hose should be held up to those parts of the car which are being cleaned, so that the water passes freely and gently down the mud, soaking into it, and allowing it to flow away with the water. Spraying the water on with force, as from a hose with a jet, only drives the mud into close contact with the varnish, and spoils it almost as effectually as wiping the mud off with a cloth. No cloth

and no rubbing should be applied to any part of the car until the mud has been completely removed by a gentle flow of water from the hose.

The other method is not quite so efficient, but is effective if carefully carried out. It is only to be recommended where water supply from a hose cannot be obtained. It is accomplished by removing the mud with a very large sponge capable of holding a considerable amount of water. The sponge should be thoroughly filled with water and held against the sides of the car, working from the top downward. It should not be rubbed along the panels at all, but should be gently squeezed, so that the water flows down along the panels naturally and carries the mud away with it.

When the car has been thoroughly cleaned from mud or dust in either of the two ways mentioned, the coach work should be carefully wiped over with a dry sponge and afterward with a chamois wash-leather. It can be finally polished with a dry leather or with any of the polishing cloths sold for the purpose. The one great point to be borne in mind if the coach work is to permanently keep its glossy coach finish is never to wipe or rub it while there is mud or dust upon it, but to gently clean off the mud or dust in either of the two ways described.

Care in Using Water—It is necessary to keep all water away from the engine and clutch. The bonnet may conveniently be kept on during the process of washing, as it will protect the carbureter, the contact maker, and the magneto (where such is fitted) from the water, but it should be taken off to be cleaned, and should be treated in the same way as the car, but not while attached to it. Water splashed about the carbureter or magneto will inevitably cause trouble. It requires only a small amount of water in the carbureter to completely stop the engine, while water on the magneto will just as effectively upset the ignition, with the same result.

This general clean-down after each day's run should take place at night, or immediately the car enters the garage. If left until morning, the mud will harden and dry, and it will

not only be more difficult and take longer to remove, but it will also, to a certain extent, damage the surface of the coach-work.

When cars are run in districts where the roads are treated with coal tar or other mineral binding surfaces, these are likely to be thrown up in wet weather, and, being of an oily nature, will sometimes attack the varnish in spots. Where cars are run on such roads, it is imperative that they should be washed immediately, and before the mud dries, otherwise, when the mud is cleared away, dull spots will appear on the surface of the coach-work, where the coal tar or other substance has splashed up.

Overheating—Immediately a car comes in after a run, it is advisable to ascertain if any overheating has taken place. Of course, it is only immediately after the car has stopped running that excessive heating, through faulty lubrication, faulty circulation, or friction set up through badly adjusted parts, can be ascertained.

The driver should feel the brake drums both on the back wheel and the countershaft. If these are hot, and yet there has been no excessive braking strain put upon the car, he may take it for granted that there is something wrong with the brake adjustment, that is to say, probably the brakes have been actually touching, even though they have not been put into actual operation. The height of the water in the radiator should be ascertained, as by this means the driver will be able to guard himself against running the car short of water.

Lubrication—The overhauling and preparing the car for each day's run amounts mainly to its careful lubrication, to the supplying of the necessary water, lubricating oil and gasoline. The first thing to do is to fill up the radiator, giving the engine a few turns by means of the starting handle, so as to insure that there is no air lock, and that the water is circulating properly.

The oil tank should be examined and filled up. Where drip feeds are used, these should be tested to make certain that each one is dripping properly when the engine is running, the engine being started up and run slowly for this purpose. It

should be ascertained that there is sufficient oil in the crank chamber and in the change speed and differential casings. Different cars vary as regards the amount of lubrication required for the different parts, and the length of time that one charge of lubricant to each part will carry the car without excessive friction.

Too much oil in many cases is almost as bad as not enough, as it frequently interferes with ignition and causes unpleasant smoke. By watching your oiling system closely you will soon be able to regulate it carefully and have just the proper amount. Generally speaking a car requires about one quart of lubricating oil to five gallons of gasolene, but, of course, this varies somewhat with different cars and different weather conditions.

Generally speaking, we may say that all those parts which are fitted with oil holes as distinct from actual oil feeds or screw-down grease cups should be oiled each morning, and should, in the case of a long run, be oiled also during the mid-day interval of running.

Such will include spring shackles, the joints of the levers and connecting links operating brakes, the bearings in which the brake levers and the change speed lever oscillate, and the links and levers which connect these up to the brakes and change speed gear, respectively. Also the bearings in which the clutch pedal operates, the links with their joints which connect it to the collar of the clutch, the heads of the steering pivots about which the steering wheel moves, the links with their joints and levers which connect the steering wheel to the road wheels, and such exposed shafts as the shaft driving the pump, the magneto, the fan, the lubricating system, etc.

Screw-down grease lubricators should be given a turn or a turn and a half, each day. In those cases where they are fitted to running mechanism which has considerable wear and tear on it they may be screwed down further or more frequently.

Gasolene tanks should be filled, and in cases where the carbureter is pressure fed from the exhaust, it should be ascer-

tained that the pressure system is in order, and that no obstruction or leakage is taking place in the unions of the pipes. By pumping up with the auxiliary hand pump, so as to get pressure in the pressure tank and then attempting to flood the carbureter, the operator may determine whether the feed is working properly. The same precaution should be taken in the case of the lubrication tank, where this is supplied by exhaust pressure feed.

Brakes—Having made sure that each part is properly lubricated, and that the lubrication system is in working order and is fully supplied, attention should be directed to the brakes. These should be tested each time that the car goes out and before it goes out. The brakes may be disengaged, and the car swung backward and forward by hand and the brakes applied meantime, when it will be readily seen whether they come into full operation or not.

Care must be taken that neither the hand brake nor the foot brake lever can be moved to its fullest extent—in the quadrant in the one case, or the slot in the footboard in the other. If they can be moved so as to come into such contact, the brakes require adjustment, because the full braking effect could not be applied in case of emergency.

All levers and operating mechanism should be tested to see that there is no excessive looseness at any of the joints. Where such is found to be the case, they should be adjusted by the means provided. All important bolts and nuts, especially those holding the steering gear and its connections, should be examined, and, if slack, should be carefully tightened up and locked.

Tires—The tires also should be examined. A rule should be made to keep the tires pumped to the minimum pressure recommended by the makers, and for this purpose, each time a car goes out this pressure should be checked by means of a pressure gauge, and if not sufficient the tires should be pumped to the correct pressure. It is inadvisable to test this pressure when the car comes in from a run, as the tires may then be hot, and the pressure be above normal. If the driver

travels habitually at a moderate speed, pulls up gradually, and is careful at corners, even a lesser air pressure than the minimum recommended will give good results.

Chains—Where the drive to the road wheels is by side chains it is well to see that both chains are properly adjusted and have not too much sag. When the car has been out in muddy weather, the chains should be brushed with a stiff brush and treated with one or other of the plastic plumbago lubricating compounds. This is best done by jacking the wheel up and rotating it, so that each part of the chain may be easily got at.

Ignition—As regards the ignition, little attention will be required if it is of the magneto type. It is wise, however, to run over the various connections to see that they are tight, and to fill up the oil holes at each end of the magneto armature. In the case of coil and battery ignition, the contact maker should be inspected, and, if dirty, should be cleaned and oiled. In all cases the batteries should be tested by means of a voltmeter, and a spare battery should be kept, fully charged.

The Monthly Overhaul.

In addition to the daily examination of the car, it is advisable to go over it periodically, in a more thorough manner. If the car is used continually a monthly overhaul should be made, but if only used occasionally such an overhaul can be left for a longer period. The oftener it is made, however, the better a car may be expected to run, and the longer will be its life.

Such a detailed inspection would include attention to the following:

Valves—Examine all valves and grind if necessary, marking the position of each, so as to return it to the right place; see that springs have not shortened and are the same strength, renewing when required; set valves to open correctly, and carefully wash with gasoline before replacing.

Compression—Test compression; if bad, trace where the

leakage occurs, and replace faulty sparking plugs, washers, etc., to prevent any loss of compression; wash and clean sparking plugs; set points and test for spark before replacing.

The Pump—This should be thoroughly examined, as it is a very important part. If the water leaks past the gland it should be repacked with cotton or hemp, and tallow. If the pump is driven by friction, it will sometimes fail through insufficient grip between the friction wheel and the flywheel of the motor. The surfaces should be cleaned with gasolene, and the adjusting spring screwed up so as to hold the friction wheel more firmly against the flywheel.

Pipes and Cocks—In pipes, etc., any leakage can easily be detected and, if present, the pipes should be brazed or the cocks ground in, and any pipes which are exposed to friction through vibration should be protected or stayed. The water pipes, radiators, etc., may be washed out by keeping a stream of water flowing through from a hose pipe or bucket while the engine is running, the overflow carrying away any accumulation of dust or dirt.

Batteries—The batteries should be tested with a voltmeter to see that the voltage is not below 4 volts. In case the electrolyte is below the level of the plates the cells should be filled with distilled water to just cover the plates.

Ignition System—Worn or frayed wires of the ignition system must be replaced by new ones; coil or contact maker platinum points leveled and made smooth; contact maker washed quite clean with gasolene, and in the case of a wipe contact, freshly lubricated with thin oil, such as is used for bicycles. Contacts will require to be re-set to get the best sparking results. In the case of high tension magneto or synchronized ignition, the distributor should be cleaned.

Gear Box—The top of the gear box should be taken off and the plug at the bottom opened to allow dirty oil to run out.

The box may then be filled with kerosene and the engine run for about one minute and the box then emptied again. The gear wheels and bearings, which should then be quite clean, should be examined. If the latter are loose they should be tightened. After the box has been cleaned, it must be filled with oil or grease to the correct level, and the top put on. In the case of gear-driven cars the same procedure should be followed with the differential gear and live axle casing.

Base Chamber—The oil should be run out of the base chamber, and after replacing the bottom plug a pint of kerosene should be poured in and the engine operated by hand for about a dozen turns, care being taken that the ignition is switched off. The plug should be removed once more, the kerosene allowed to run off, the plug replaced, and lubricating oil inserted up to the overflow plug. On no account should the engine be run until this has been done, or the pistons may seize.

Carbureter—The carbureter may be examined next to see that it contains no sediment, and that the spray nipple is quite clear. The needle valve that controls the supply of gasolene may require grinding in, and care should be taken to see that the float is not punctured.

Chains—These should be removed, cleaned in kerosene, soaked in melted tallow and graphite, and then lubricated.

Brakes—The brakes should be examined at frequent intervals, as the safety of the automobilist is absolutely dependent on them. Worn cables ought to be replaced, friction faces washed and renewed, if necessary, and all bolts tightened up.

Wheels—The wheels must be detached, and the old oil or grease wiped off the axles and out of the boxes. Fresh washers may be required to take up any rattle or play. Both axles and boxes should be oiled and wheels replaced and tightened up until there is no side shake. Where grease is used for lubricating, it is well to mix a little oil with it.

Nuts and Bolts—All bolts in every part of the car, but especially in the steering gear, springs, etc., should be tried with

a wrench to insure their being quite secure, and, where possible, nuts should be pinned.

Tires—Cuts in outer covers of pneumatic tires should be filled with some of the special preparations supplied for the purpose and vulcanized to prevent wet getting into the canvas. All large cuts and blisters should be strengthened on the inside with additional patches of canvas vulcanized in position. Inner tubes should be tested and repaired, if necessary. For such work a vulcanizer is indispensable.

Lubrication—Grease pots should be cleaned out, refilled, and then screwed up tightly, so as to insure the grease reaching the bearings; then refilled again, and so left ready for a run. All the mechanism in connection with the system of automatic lubrication should be inspected and adjusted; sight feed lubricators washed and their needle valves adjusted, or ground in, if required; the oil tanks or cups should be filled and tested to see that they are in working order.

Filters—These should be opened and cleared of sediment. This refers to the inlet filter to the gasolene tank, the outlet filter to the carbureter, the filter in the inlet to the water tank, the filter of the by-pass or exhaust (either to carbureter jacket, gasolene tank, or oil tank), and the filters in oil tanks or oil feeds, as well as the filter or filters in the bottom of the crank case, in cases where the oil is lifted from this and circulated through the engine bearings by a pump.

COMPLETE OVERHAUL.

In addition to the daily or weekly inspection of the car, and the attention to any points which may develop during the course of usage, it is highly advisable to occasionally make a complete overhaul of the whole of the mechanism, from the engine right down to the road wheels.

This will necessitate, in most cases, some amount of repair, and always considerable adjustment. If, after an overhaul such as described here, trouble is located, the remedy will be found under the respective headings in this volume.

These sections should be studied in conjunction with this article, where a complete overhaul is contemplated.

A periodical overhaul enables the owner to assess approximately the depreciation of his car, and to ascertain cases, if any, where it has been wrongly treated, either negatively, through neglect, or positively, through bad methods of adjustment or repair.

The mechanism of different cars varies very considerably, and, therefore, different methods in overhauling have to be adopted according to the different types of construction. To facilitate the reader, we have divided the subject up into separate and distinct sections, and naturally deal first with the engine.

The Engine.

It is, of course, of the greatest importance that the operator should ascertain the condition of the pistons and their the bottom half of crank case is cast separately, and the bearings, and the crankshaft with its crank pin bearings. When the bottom half of crank case is cast separately, and the bearings hung from the top in brackets, the big ends of the connecting rods and the crankshaft bearings can be examined by simply taking off the bottom half of the crank case. In cases where pump lubrication is applied there is often a considerable amount of piping and accessory mechanism attached to the bottom of the crank case, which will have to be dismantled before the crank case bottom can be taken off.

Here it may be well to say that, in dismantling any part, it is necessary to carefully examine and clean all nuts, bolts, washers, universal joints, shafts, and bearing pins before they are put together again, and it is advisable to keep the different parts of one unit in the construction separate, so that, in reassembling that one unit, all its different parts will be found in one place. This will considerably simplify the reassembling of any unit taken to pieces. To assist in this, it will be found a great advantage to have a number of boxes of various sizes. Some of them will require to be fairly large, while others, such as, say, a box to hold the component parts of the

magneto ignition system, would not necessarily require to be so big. To take down the engine, the best procedure is to take the crank pin bearings apart and release the big ends of the connecting rods, in which case the pistons and connecting rods will come away with the cylinders. This is a great advantage when we come to take the cylinders off, because it is much better to be able to take out and put in the pistons while we can hold the cylinders in a convenient position on the bench, than to have to lift the cylinders off the pistons. In cases where the cylinders are cast in pairs, or in fours, this becomes a very awkward job, especially to reassemble, not only on account of the number of pistons which have to be fitted into the cylinders, but also on account of the weight which has to be supported and put into position. It should be remembered, therefore, that when the big ends of the pistons can be got at it is well to free them from the crank shaft before commencing to take the cylinders off. In some cases instead of the bottom half of the crank case coming away as a separate cover, it will be found that inspection doors are fitted in the side of the crank case, and very often these are of sufficient size to enable the big ends of the connecting rods to be uncoupled, and so release the cylinders and pistons together.

Removing the Cylinders—In cases where no provision is made in the crank case for getting at the big end bearings, it will be necessary to first remove the cylinders. In practically every case these are bolted down on to a flat surface on the top of the crank case by means of four or more studs and nuts, the studs being screwed into the aluminum top of the crank case, and the nuts holding the cylinders down by a flange—generally a sq are flange with the nuts at the four corners. Before the cylinders can be taken off, the piping will necessarily have to be taken down, and the arrangement of the piping generally will determine which section of it should be taken down first. In the majority of cases it will be found advisable to first disconnect the carbureter. In doing this the connecting rods and links which connect the carbureter

to the operating links, or the accelerator, will first have to be taken down, and the best plan is to see that, when these rods and levers are taken off, the numerous pins by which they are connected are put back into their respective holes, so that the same pin will go back into the same place when the parts are being assembled again.

The carbureter having been taken off, no difficulty will be experienced in next dismantling the gas pipes leading to the inlet valves. In some engines there is no large amount of piping, as it has become the more popular practice to cast the ports for the inlet valves in the walls of the cylinders themselves. In other practice it will be found that all the pipes leading to all the inlets are cast as one piece, in which case, of course, the dismantling is very easy, they being held on generally by not more than four nuts (or in some cases yokes are used, so that one nut can hold more than one part and make more than one joint). It is good practice before breaking any of the joints of the inlet pipes, exhaust pipes, or water connections, to first brush kerosene around them, so that the packing, whatever it is, may be softened, and allow the joints to come away without tearing the packing. In the case of the gas inlet joints these will generally be found to be made of thick paper or card soaked in linseed oil, and it will save the trouble of cutting new packing or washers, if care is taken, in taking off the pipes and breaking the joints, not to break this. The time occupied in allowing the proper soaking and softening of the paper is well worth expending.

Having taken off all the inlet piping, the exhaust piping should next be tackled. It will be found in the majority of cases that the joint between the exhaust pipes and the cylinders will be made by thin asbestos washers; in most cases it pays to put in new asbestos washers, but if this is not done it is advisable to soften with water those already in position to prevent breaking when the joint is taken apart. The exhaust piping will be found to be connected to the piping which leads underneath the car to the muffler generally by means of unions. Only the first of these unions should be unscrewed, as it will

seldom be necessary to take out the whole of the exhaust piping, the object for the present being only to free the engine cylinders so that they can be taken off.

Governing rods and such-like appliances operating and governing low tension igniters on or near the tops of the cylinders will have to be uncoupled, and it is of the greatest importance that the method of adjustment as to their length, or the angularity of the levers which operate them, should be carefully marked before unscrewing any of the parts. Where the two parts come together with a flush surface a fine line filed across the two surfaces or edges with a small, smooth file will locate them for reassembling, or, if the surfaces do not come together in a way which allows of convenient use of the file, two small center dots, made with a center punch, and adjacent to each other, will be a sufficient guide. Too much emphasis cannot be laid on this careful ascertaining beforehand of the position of the parts, and marking them so that they can be afterward put together in exactly the same order and with exactly the same adjustment. Any time spent in making the marks, or even in making a rough diagram or sketch, will be time well spent, and may save considerable trouble, and even injury to the car subsequently.

As regards the wiring of the ignition, this will be dealt with later among the engine accessories. But it is always advisable to remove the sparking plugs so that they will not be likely to get injured by heavy objects coming against them, such as spanners or parts of the inlet or outlet tubing. In the case of low-tension ignition, it is best to leave the igniters in their places on the cylinders. With the cylinder on the bench these can be got at in a much more convenient manner.

The water circulation pipes will have to be cleared from the cylinders before they can be lifted from the engine. Frequently they are kept together by rubber tubes, which fit over the adjacent ends of copper or brass tubes, and are held together by band clips. These band clips being loosened, and the rubber tubing carefully lifted from contact with the tubes, they will be free to move, and they may be slipped from one

tube to the other, until the joint between the two tubes is exposed. The undoing of these joints will leave the cylinders free of each other and also free from the radiator and the pump. The pump is generally applied as part of the engine mechanism, and attached to the crank chamber casting, and it is not usually necessary to dismantle it in order to take off the cylinders.

If the big end bearings cannot be previously uncoupled, the cylinders will have to be lifted off, leaving the pistons, with their rings in position, standing up on the top of the connecting rods. This means, of course, that in lifting off the cylinders they must be pulled up vertically and quite straight. As they are heavy masses of metal, care must be taken in doing this; otherwise should they be allowed to tilt over, it is possible that they will put a great strain on the pistons and the connecting rods, in some cases setting up such a strain as to actually bend the connecting rods, when it is obvious that the bearings will be interfered with, so that one or other of the connecting rod bearings will not lie parallel with its journal when it is assembled again. It is very necessary to take considerable care when lifting off the cylinders. One man standing astride the chassis will generally be found capable of lifting them off, and there will be less likelihood of a cylinder being tilted sideways than if two men were to try to lift it off at the same time.

In cases where the big end bearings can be previously uncoupled, it will be advisable that someone should be ready, while the cylinders are being lifted, to push up the connecting rods, so as to insure the pistons and connecting rods coming away with the cylinders; that is to say, so that the cylinder with its piston and connecting rod can be taken completely away at the same time. If the inlet and exhaust valve passages are blocked up with a linen rag—not cotton waste—the suction of the piston inside the cylinder will tend to keep it in place, and allow it to be drawn up along with the cylinder, but it is advisable to have the help of a second person in order to

ascertain and insure that the piston and connecting rod are remaining in the cylinder and coming away with it.

In cases of large cars, and especially where four cylinders are cast "en bloc," the weight of the cylinders may prove too much for one man to lift, and it will then be advisable to rig up some kind of hoisting tackle, so that the power of two or more men may be applied somewhere near the center of the mass in order to prevent the tilting over so likely to cause injury.

The cylinders having been taken off, they should be laid aside, with their pistons in them, and it will be advisable to mark the pistons, as it is necessary that these should not be turned round in their cylinders. Very often the center line of the cylinder is not the center line of the connecting rod bearings or the crank pin bearings, so that it will be seen that if the pistons were turned round in their cylinders these bearings might not go together again, and considerable trouble might be caused in ascertaining why they did not do so properly. Just a slight file cut across the mouth of the cylinder and the mouth of the piston is sufficient to insure locating them again accurately.

The Crankshaft—The crankshaft will now be exposed in its bearings, and free from the weight of the connecting rods and pistons. By moving it up and down and sideways, the operator may ascertain if there is any great wear in its main bearings. This should be done with the clutch disengaged, and the clutch should preferably be held out of engagement by blocking the clutch pedal in some way, so as to prevent the clutch from holding the shaft centrally and relieve it of a considerable amount of weight. It will be obvious that the weight of the flywheel will tend to keep the crankshaft down in the bottom of those bearings near the flywheel end, and, therefore, it is advisable to put a rope or strap round the crankshaft at this end, in order to lift it more easily and ascertain if there is any appreciable up-and-down movement. The other end of the crankshaft will be very easily moved for ascertaining this, as it is comparatively light. If there appears to

be an undue amount of slackness in the bearings—this can be judged best by an experienced mechanic—it will be advisable to take off the brasses which hold the bearings together. If the crankshaft is hung from brackets cast with the top part of the crank case, it is obvious that these caps or brackets will be actually holding up the crankshaft, so that before undoing them it will be advisable to block up the crankshaft in some way by blocks of wood or by hanging it by ropes from pieces of wood placed across the opening in the crank case where the cylinders are attached. Otherwise, after undoing one or two of the bearings, so much strain might be put on the others as to cause the weight of the crankshaft to strip the threads of the holding up bolts.

In some cases, as in the earlier types of engines, the crank case is divided horizontally in a plane which intersects the crankshaft axis. In such a case, the cylinders having been removed and the bolts holding the two halves together having been taken out, the whole of the top half of the crank case can be taken away. The crankshaft with its bearings will then be exposed to view. The camshafts will generally come away with the top half of the crank case, and therefore it will be necessary before taking this off to take down the aluminum casing which encircles the timing gear wheels at the end of the crank case.

In more modern practice, however, the camshafts—sometimes only one, and sometimes two, one on each side—are slipped through bodily from one end, generally the front end, and to take them out it is necessary to take off the front cover incasing them, and also to take off the radiator, in order to allow them to be drawn forward. It is not often that the camshafts need attention, unless considerable noise has been ascertained to be taking place here, or when the wheels which drive them feel loose.

The taking off of the radiator is a very simple operation. By undoing four nuts, two on each end, which bolt down to the chassis frame, the radiator may be bodily removed. The

support at its top is usually provided by means of the outlet water pipe itself.

The Magneto—In cases where a magneto is fitted, it is well to detach this from the engine and lay it on one side, so that it will not be injured either by heavy objects or by oil which may be used for cleaning purposes. As a rule, it is one of those parts which can be attached to the engine last when re-assembling. It may, therefore, be taken completely away; but before doing so it must be remembered that the coupling which couples it to the shaft which drives it will have to be marked. Supposing the magneto is driven by a chain, it will only be necessary to mark a link of the chain and a tooth of the chain-wheel on the magneto, and, similarly, a link of the chain and a tooth of the chain-wheel which drives it. One of these links should also be marked to show which is the top and which is the under side of the chain. If they are then put back with these marks adjacent to each other there will be no fear of the magneto being put out of time. These same remarks apply, throughout the engine mechanism, to any wheels which may be taken out of mesh with each other, but before making any marks it is well to be certain that no marks already exist, or that if such marks do exist they coincide. Thus, to insure that a set of toothed gears come together in the same relative positions, the tooth of one, and the space in the other with which the tooth engages, should be marked. Generally, just a center punch mark will be found sufficient, and if the wheels are already marked new marking is, of course, unnecessary. Care should be taken, however, to thoroughly understand the meaning of any marking which happens to be there, and to provide against the danger of the relative marks being forgotten, it is often well to make a rough diagram by drawing circles adjacent to each other representing the wheels—such as the timing wheels operating the valve shafts of the magneto—on a piece of paper, and to mark them similarly to the marks on the wheels themselves. This can be easily referred to afterward when reassembling.

It is of the utmost importance that in no case should two

wheels be taken out of mesh with each other without definitely ascertaining that they can be put together in exactly the same relative positions, and any time spent in thoroughly determining that this can be done will be time saved.

The Bearings—The engine being completely dismantled, all the parts subjected to wear or movement should be examined, so as to determine their condition and decide on any replacement or adjustment that may become necessary.

If the engine has seemed noisy, or a knock has been heard, the cause of it may be found in any of the three sets of bearings—the crankshaft or main bearings, the big ends of the connecting rods, or the gudgeon pins (or small ends of the connecting rods).

The test for play in the main bearings must be made when the brasses—top and bottom—are in position and screwed down tightly upon each other. The end bearing next the fly-wheel and clutch will be the most likely to have worn slightly.

Exactly the same considerations apply in the case of the big ends of the connecting rods. These are, of course, easier to get at, and to test for slackness, than is the case with the big main bearing of the crankshaft. The rods should be taken out of the pistons by withdrawing the gudgeon pins, which, when the locking screws, or whatever else is used to hold them firmly in the piston, have been removed, will come out endways, thus freeing the connecting rod.

The Gudgeon Pins—It will be necessary before withdrawing the gudgeon (piston) pins to see if they are tight in the piston—which, of course, they should be. If they are slack, the cause of the slackness should be ascertained. If it arises from not being properly locked up in the bosses in the piston, the remedy is obvious. If, however, the cause is that the pin, or the holes, in which it should be a god fit, are worn, a new pin will be the only real remedy.

It will be necessary to carefully examine to see whether the pin can move endways in the piston. It should not be able to do this, otherwise it may protrude through the piston

side, and, as the pin is invariably hardened and the cylinder is of comparatively soft metal, it will inevitably cut grooves in the inside of the cylinder walls, which will result in loss of compression, and consequently power, and other troublesome symptoms.

A Scored Bearing—There is another point about all the engine bearings which should receive attention. They may be found to be cut or scored on their surfaces. This is indicated by lines and grooves around them in the direction of rotation, some of the deeper of these lines in the brasses showing a darker color. An examination of these lines with a magnifying glass will disclose the fact that the metal has been actually torn out in these grooves or lines. This denotes want of proper lubrication. The darker color in the deep parts of the grooves gives evidence of the fact that the bearings have actually at some time, or times, run hot.

This condition of affairs may have been arrived at gradually; or it may have been set up in the course of one short run during which the engine had been allowed to run dry. Whatever the cause, the condition is a serious one, and requires immediate attention, for however well a scored or cut bearing may be lubricated, it will always tend to run hot, and its condition will gradually, but inevitably, get worse. The remedy for this trouble is the careful re-scraping of the brasses.

The Cylinders and Pistons—An examination of the cylinders and pistons should next be made. We will suppose that the valves have been taken out, care being taken to first mark them, so as to be able to determine which cylinder they have come out of (one, two, three, or four filed notches at the edge of their heads will suffice for this purpose, if they are not already marked). We will deal first with the wearing surfaces between piston and cylinder.

As regards the bore of the cylinder, if nothing untoward has happened—such as the coming adrift of a gudgeon pin—the bore may be expected to be smooth to the touch and highly polished.

If it is so all round and for the length of the piston's travel, we may take it that nothing very much the matter exists. If, however, the engine has been badly treated, allowed to get too hot, or insufficiently lubricated, we may find scored lines running up and down the cylinder in the direction of the travel of the piston. This can only be remedied by competent engineers.

The piston should now be inspected. The piston fits comparatively loosely in the cylinder, as it must at all times move freely within it, and the enormous variations in the temperatures inside the cylinder cause varying differences in size between the cylinder bore and the outside of the piston. It is unlikely, therefore, that any wear of importance will be found to have taken place on the actual surface of the piston itself. It is the spring piston rings which make the close contact between cylinder walls and piston which is so necessary to insure the fullest possible measure of compression and to prevent blowing past into the crank chamber of any of the expanding gases on the power stroke. The removal, cleaning, and replacing of the piston rings is dealt with in another chapter.

As to Carbon Deposit—Next examine the combustion chamber, valve chamber, and inlet and exhaust ports and passages to ascertain whether there is any excess of carbon deposit. There will, of course, always be a certain amount, dependent on the length of time the engine has been running since the last clean out, or since it first commenced work. An excessive amount will show itself by lumps and ridges of hard carbon, which may sometimes look like a rough part of the casting, but which, if struck with a chisel or other sharp-ended instrument, will shell or flake off.

The valves should be examined, and any which are found to be pitted on their seats may be carefully ground in the usual way, taking care to keep the emery from the inside of the cylinder or from the guide through which the valve stem passes.

While the cylinders are off, advantage may be taken of their

accessibility to examine the water jackets, and see if any furring up or corrosion has taken place.

The Valve Gear—In very few cases will the valve gear require any attention. The plates which hold down the valve plungers are usually screwed down on the top of the crank case, and, when these are taken off, the plungers can be taken out complete in their guides. Various types of plungers are used. Some have simply solid hardened steel heads resting against the cam, and which the cam rotates against and lifts. Others have hardened steel balls lying in sockets, while others again—and these the majority—have rollers running against the cam. These rollers are usually hardened, and rotate on hardened steel pins, so that it is unlikely any wear will take place here. If, however, wear does occur, roller and pin should be replaced.

The cams on the camshafts should next be examined, and if the wear on their bearing surfaces be excessive, it may be necessary to replace them; this, however, will rarely happen, for as a rule the wear of the cam is pretty equal all around, and it does not much affect the lift. With cams as at present constructed, machined out of the solid with the camshaft and hardened and ground, wear will hardly ever be found to have taken place. What applies to the camshaft and the plungers applies also to the cams operating the low tension igniters, if such are fitted. In this case, owing to the very light nature of the work which they have to accomplish, it is not likely that any wear which would upset their operation will be found.

The Lubrication System.

The lubrication of the bearings will require attention. All lubricating pipes should be taken out and thoroughly cleaned, which is best done by forcing kerosene through them. This will clear out all gummed-up oil which may be obstructing the passages. The oil pump, where one is fitted, should be dismantled, and any accumulated deposit cleaned out with kerosene or gasolene. The latter is the easier method, but more expensive. Where any stale gasolene is at hand, however, it may be conveniently used for this purpose.

It is not likely that the mechanism of the oil pump will suffer very much from wear, owing to the fact that it is constantly rotating in oil, and has no very heavy duties to perform. It is well to see that all the oil "leads," or pipes, conducting the oil through the crank case casting to the main bearings of the engine, are quite clear, and that there is a through way into the bearings; if not, the obstruction must be removed. Many crankshafts are made with oil "leads" running right through the center of them and up the crank webs and out through the crank pins. It may be easily ascertained whether these are clear by filling up the "leads" with oil or kerosene and then blowing through with a tire pump. If the oil is easily forced through to the other end of the oil "lead," it may be taken for granted that there is no obstruction. While overhauling the lubrication, it will be well to examine the sight feed lubricators on the dashboard where such are fitted, and to clean out the glasses to insure their working correctly.

Taking Down the Clutch.

We should now turn our attention to the clutch. The procedure will vary according to the type of clutch used, and to the method in which it is applied and fixed. As a rule, there is some form of detachable coupling between the clutch and the gear box, which, when detached, leaves sufficient room between the two to allow of the dismantling of the clutch. Where such is not fitted, as in some of the earlier types of cars, it may be necessary to unbolt the gear box and shift it bodily backward on the chassis, so as to make room for the removal of the clutch. The moving of the gear box will necessitate the uncoupling of the gear control levers, and sometimes other levers. This will be referred to when we come to the overhauling of the gear case.

The clutch is generally dismantled by uncoupling the fork which encircles the collar and allows of the disengaging of the clutch, either by pressing it in, or drawing it out, according to the construction of the clutch. This will have to be removed, and with it may be removed the bracket or brackets carrying the rocking shaft on which it is pivoted. The proce-

dure then will vary considerably according to the type of clutch, but it is safe to assume that in all cases it is advisable to plainly mark the parts as they are taken asunder, so that they may all be put together again in their relative positions.

The clutch having been freed from the fork, and the necessary bolts and nuts undone, it can be pulled out endways. This will necessitate the uncoupling of that portion which the spring presses against in forcing the two parts of the clutch into engagement, and this should be done carefully, otherwise the pressure of the spring, when the parts are released, may cause some damage. The several necessities of the case will indicate the procedure, which varies with different types of cars.

The adjustment of the clutch can only be done after it is assembled again, and provision is always made for adjustment, but it will not often be found that such adjustment is necessary, as the driver will naturally make the adjustments as they become necessary in the ordinary course of attention to the car.

Where a new clutch leather has been put in, or where new disks or plates have been applied, it may be that considerable adjustment will be necessary. The user will be the best judge as to the amount of play the clutch should have when in the disengaged position, and how far the clutch pedal should be back when the clutch is in engagement. For full particulars as to the proper treatment of the clutch.

Reassembling.

This practically completes the taking down and examination of the engine, with all its various added appliances, and it may be advisable before proceeding with the taking down of any other part of the car to reassemble the engine. Little need be said as to this; the sequence of operations will be indicated by the sequence of the operations in taking the engine apart, those parts first removed being those which will be the last to be assembled together again.

The fitting of the pistons with their rings inside the cylin-

ders is not by any means an easy job, and great care must be exercised in this operation in order to insure that the rings are fitted in with their joints equidistant from each other. In putting in the pistons care must be taken not to turn them round, and to replace each piston in the position which it will occupy as indicated by the marks made upon it. It is obvious that if the piston were partially rotated after one or more of the rings were placed inside the cylinder, it would be likely to rotate upon the ring, and the position of the rings would be altered relatively to each other.

In the majority of cases the mouth of the cylinder is belled out or tapered, so that, by pushing the piston up into the cylinder the taper in the mouth of the cylinder will gradually close the ring in its groove until it will slip up inside the cylinder.

Packings—All packings for the joints, such as between the cylinder and the crank case, the inlet pipes from the carbureter, the exhaust pipes, and the water pipes should be made good either by using the old packing, or, if that be torn, new packing. An old paper packing, or asbestos packing which has been torn across is practically useless, as it will never be really tight, and leakage will take place. Good, stiff wrapping paper well soaked in boiled linseed oil makes as good a packing as can be desired for those joints which are well faced up. In some cases, where the faced joints have been scraped, as distinct from having been only planed or otherwise machined, a joint may be made without any packing whatever by simply cleaning the two surfaces with emery cloth and smearing them with boiled linseed oil before putting them together. It is necessary in such cases, however, to be quite certain that there is no foreign matter between the two surfaces before they come in contact; even a minute piece of grit will prevent the joint from making proper contact and will cause leakage, and if any doubt exists as to such a scraped joint being quite tight the remedy of the wrapping paper oil-soaked packing will insure that everything is tight.

Any packing that is provided in the joint between the flange

of the cylinder and the top of the crank case will necessarily lift the cylinder relatively to the crankshaft, so that it is necessary that if any new packing is inserted here it should be of the same thickness as the packing which was taken away. If it is thicker it will slightly alter the area of the combustion space and slightly reduce the compression. If it is thinner it will cause the piston to move higher up in the cylinder and slightly increase the compression. These differences, of course, will be very slight; nevertheless, it is advisable to see that the packing is of the same thickness as was originally inserted, and of the same thickness under all cylinders in the case of multiple-cylindered engines.

Reassembling the Valve Gearing—In reassembling the valve gearing and the valves, it is well to remember that any wear which takes place between the cam and the plunger or between the plunger and the valve stem will make a difference in the height to which the valve will be raised from its seat, and therefore in the area of opening for the incoming or outflowing gases. As a very slight difference in lift makes a very appreciable difference in area, it will be seen that if the wear between any of these parts is excessive a throttling action on the inlet and exhaust gases will take place. Conversely it must be remembered that every time the valves are ground in, the valve stem is practically lengthened, so that the wear taking place at one end and the grinding down of the valve at the other may, to some extent, equalize each other.

General Hints—Some other general remarks may be made regarding the reassembling of parts generally. Surfaces which come into contact with each other should be cleaned, and the work should be performed in as clean surroundings as possible so as to prevent grit and other foreign substances getting in between working surfaces. It is generally advisable to smear working parts with oil when assembling them, and it is very good practice to put a drop of oil on a screw or a bolt before tightening it up. This prevents any danger of seizing, and allows the bolt or nut to be tightened up quite firmly, while, contrary to what might be expected by the uni-

nitated, the oil has no tendency to help the nut or bolt to shake loose, and it has the advantage of preventing the rusting up of bolts which often occurs in such places as on exhaust pipes and water connections. The condensation of the atmosphere on the exhaust pipes is very noticeable, and often—in fact, generally—sets up rust on the connections and unions. This latter may be to a very great extent obviated if plumbago paste is brushed on to the parts when reassembling. This will act as a lubricant in screwing the parts together, and will also prevent rust, and will be unaffected by the heat of the exhaust.

Overhauling the Change Speed Gear.

As regards the gear, the procedure in overhauling this will, as in other cases, vary according to the type of gear. For our present purpose, we will exclude from consideration any but the most representative types. Gears using expanding clutches to fix the gear wheels to their shafts, or epicyclic gears, or gears using sliding feathers and keys, will have to be treated according to their own particular requirements, and the effect of wear will be shown in these in different ways according as the different actuating parts have to bear the strain or pressure. It might be mentioned that where expanding clutches as in the De Dion car, are used, very careful adjustment becomes necessary, and an overhauling, if the gears are to be taken apart for examination, is not so easy a job as in the case of the more representative sliding type of gears. The same applies to epicyclic gears, and with all these the manufacturers generally supply concise directions as to adjustment and overhauling. It will be best in all cases to apply to them for the necessary information, and often advisable to get the overhauling done by the manufacturers themselves.

See to the Operating Gear—In most later types of cars the gear shafts run on large ball bearings, and the division between the two halves of the gear box is higher than the centers of the shafts. In such cases the shafts, instead of being let down in their bearings, as in the older types, are pushed into position endways, the different wheels being threaded upon

them on a square, or on a castellated section of the shaft, the ball bearings being pushed into position endways after the shaft is in position in the gear box and with its wheels upon it. If a wheel is very badly damaged the only remedy is replacement by a new one; doctoring up the teeth of gear wheels is never a successful operation, and at best is only a very temporary remedy. Derangement is more likely to occur through wear in the operating levers or rods.

It is not usually necessary to disconnect the controlling levers and mechanism for the examination of the gear box, although in some cases the constructional arrangement is such as to necessitate this. If, however, it is found advisable to remove these, or uncouple them, it is imperative that proper marks be made so as to determine that they will go back together in the same position as before. A very slight difference in the angularity of a lever on a rocking shaft will make all the difference in the amount of travel of a rod which it operates. In some gears, even although all the joints were tight and well fitting, if the position of a lever on a shaft were altered, and even if everything seemed to be working easily and without shake, it might be found that the operating rod did not carry the gear wheels for enough into mesh with each other. It is therefore necessary in replacing the gear box or any part of the gear box mechanism to insure, before fixing all up, that on each change of the change speed levers the gears which ought to be in operation are fully in mesh with each other. Also that there is no chance, owing to wrong adjustment, of any other gear either getting into mesh while one is already in operation or getting so near an adjacent wheel as to cause damage to it.

Oil should be Examined—The oil which is taken out of the gear box should be carefully examined to see that there are no traces of grit or metallic dust present, such as would indicate the grinding away of the wheels, for even if this goes on to a very slight extent, the metallic particles will eventually get into and cut up the bearings. If anything of

this nature is felt in the oil removed from the gear box, very careful examination should be made to determine where it comes from. The joint between the bottom and the top halves of the gear box, where it is divided, should be carefully cleaned, and a good joint made with wrapping paper and linseed oil; otherwise the lubricant will leak out, and dirt and grease will accumulate, which will not only be unpleasant, but will detract from the wearing qualities of the car.

In cases where the car is chain driven, an examination of the change speed gear will also include the differential gear, which in such types, is usually placed inside the gear box. This will mean also an examination of the driving shafts and their bearings—that is, the shafts which carry at their ends the chain sprockets. Any play in these bearings should be dealt with in the same way as in the case of the engine bearings.

Chains and Chain Wheels.

Chains should be examined carefully as to stretch. If the chain is so far stretched that it cannot be laid completely round the large sprocket wheel, with every roller properly embedded in the tooth space, it may be regarded as having stretched too far, and should be replaced. Wear on the sprockets will be more noticeable on the small sprockets on the end of the countershaft; the teeth instead of having a cycloidal form will be undercut, or worn hollow by the rollers of the chain, the result being that the wheel will tend to hang on to the chain and that the chain will not clear itself from the sprocket easily as it runs off. If the sprockets have worn to such an extent they should be replaced.

Live Axle and Differential.

Where a live axle drive is used, attention should be given to the universal joints at one or both ends of the transmitting or cardan shaft. If kept clean and properly lubricated the wear here will be very slow, although, in some methods of construction, there are possibilities of considerable slackness and wear taking place. As there is usually no adjustment to

these, it is necessary, if the play has become too great, to replace the parts which are worn. As regards the live axle and differential type of car, wear in the bearings will make itself apparent in a considerable amount of backlash between the bevel crown wheel and the bevel pinion. Usually provision is made for taking this up endways, so as to bring these two wheels into closer mesh with each other, but owing to the fact that a very slight alteration in the relative positions of two bevel wheels will make a very considerable difference in the friction which they will develop in transmitting the power, it will be found advisable, if there is any great wear, to get the adjustment made by a competent engineer who will know exactly how deep it is safe to put the teeth into mesh with each other.

The road wheels, in the case of old cars, generally run on plain parallel bearings of some anti-friction metal, such as bronze or some of the bronze alloys. If wear here is excessive, it will generally be noticed, owing to the fact that the wheels will not stand vertically on the ground, but will tend to incline inward toward the body of the car.

The Brakes.

The brakes will require attention. If the car has been well used, brake adjustments will have been made from time to time as they have been required; but it is well to take down all the brakes, in order to ascertain whether they are so much worn as to require repairs or renewals.

To get at the internal expanding brakes, the wheels will have to be removed.

The brake shoes are fitted on a circular plate attached to the outside of the axle, and the drum against which they expand is carried on the wheel, generally being bolted through the spokes, or else forming part of the solid steel of the hub. By withdrawing the wheel from its axle endways, the whole of the braking mechanism will be exposed.

The action of the toggle, or the cam, or whatever other movement actuates the shoes and causes them to expand, should be carefully examined.

In the case of brakes operated by cables (such as will be found in some of the older types of cars, in which the cable runs over the curved ends of two levers on a rocking shaft, and passes through the center of this shaft, being anchored at either end on the two brakes on the road wheels) this cable will have to be taken out and carefully examined. If any strand of it has become torn or broken, the result will be a very rapid stretch of the cable, the strain which was formerly taken by all the strands having to be taken by a smaller number, and the cable will, of course, have become very much weakened, with the result that it might at a critical moment give way. Sometimes it will be found that where the cable has to take a violent, sharp turn into the rocking shaft it will become frayed, and in any case where any of the strands of the cable are damaged, the cable should be entirely replaced by a new one.

In all cases it is necessary to ascertain that the compensation device is working properly, and it should be taken apart and cleaned.

As regards countershaft brakes, it will be necessary to examine to see whether the wear on the shoes has been of such an extent as to bring the ends of the two shoes so near to each other as to prevent a full braking pressure being put on.

The Steering Gear.

The steering gear should be taken down completely. In most modern practice this can be very easily accomplished by undoing four or more bolts which hold the steering box to the side frame of the car. The steering wheel having been taken off, and the supporting bracket on the dashboard having been unshipped, the steering box with its column complete can be dropped down into the pit through the bottom of the car.

Of course, in cases where the carburation, throttle or ignition levers are operated by rods which pass through the center of the steering column, the connections to these different parts will have to be undone at the bottom. After thoroughly clean-

ing the worm gear with kerosene, it should be tested as to the amount of wear; if any provision is made for adjustment here so as to prevent backlash, the adjustment should be made.

The box will have to be replaced carefully, and great care should be taken to see that all the nuts are properly locked and pinned. The joints in the rods and arms of the steering gear will have to be carefully examined. In the case of ball and socket joints, after thoroughly cleaning them, they should be inspected to see that no wear has occurred to an extent such as to cause any likelihood of the ball coming out of the socket—a failure which might prove disastrous. The springs, where springs are used in the sleeves holding the sockets which encircle the bolts of the ball and socket joints, should be taken out and tested as to their strength. If any weakness is apparent, they should be replaced. It should also be noted that the spring is not of such a length as would allow, under great pressure, the bolt to force one-half of the socket back against the spring far enough to release itself, and in reassembling these joints the very greatest care should be taken to see that the adjustable end of the socket is firmly tightened up and properly locked. The leather grease-holding covers, which are usually applied round the joints, should be cleaned and put back, and if they are worn or have become weak, they should be replaced by new ones. The lacing of these should be carefully done, and they should be secured very tightly round each arm or link, as they provide a certain amount of security against the unshipping of the joints. Spring band clips used for water tubing can be recommended for securing the leather, and should be so fixed that in case of a breakage they would temporarily hold the parts together so as to render steering possible for a short period, so that the car could be run slowly to a garage or workshop. The steering heads, on which the road wheels are pivoted, should also be taken apart and examined. If they are of the plain variety with a hardened steel pin right through, this should be examined, and, if considerable wear has taken place, it should be replaced.

Springs.

The springs will require attention. The bolts in the shackles at the end of the springs will have to be taken out and examined for wear. If much worn, they will have to be replaced with new ones. In cases where the bolts are worn on one side only, they can with convenience be replaced so that the worn side comes away from those surfaces of the joint which are pressing together. The springs themselves should be examined to see that all the leaves are snugly down on each other, and that no weakness has taken place, weakness being evident if the springs assume a nearly horizontal position when the car is loaded.

Tires.

As regards tires, these should be carefully examined and treated as described at length in another chapter. Casings should be removed from the rims, and any repairs to cuts or gashes properly executed by vulcanizing. The beaded edges of the casing should be carefully cleaned free from any rust which may have been set up, and brushed with blacklead. The wheel rims should be thoroughly cleaned and scraped, and all rust should be removed with coarse emery cloth, and the rims blacklead. While the tires are off it is a good time to test the alignment of the wheels, to insure that the car is running in track. When the front wheels are placed in the straightforward position, a long straight-edge placed along against the front and back wheels, at as near their fullest diameter as the projection of the hub cap will allow, should touch the rims in all four places; the wheels being out of track may be caused by the wrong adjustment of the radius rods throwing the back axle out of square with the chassis frame. This can usually be ascertained by a line or cord held at the front of the chassis frame and just touching the back axle on one side. This cord should then exactly reach from the same point at the front of the chassis frame to the rear axle on the other side. The adjustment, should it be out of alignment, can be made by means of the radius rods. The

same method can be applied to the front axle, and if it is out of square the remedy is to slack off the bolts holding the spring on the spring plate, and so adjust the axle across the car frame.

OVERHAULING HINTS AND TIPS.

How to Save Trouble.

A large number of amateur motorists are very innocent of the internal economy of the automobiles or other mechanically-propelled vehicles which they more or less successfully drive or attempt to overhaul. To the enthusiastic amateur who does not profess to be a skilled engineer (and yet likes to do his own repairing), and to the workman who does, it is hoped that the hints given below will be—as they should if intelligently and carefully followed out—of some considerable service.

During the winter months of the year a large number of cars are laid up or are not used to the same extent as will be the case later on, and the opportunity can thus be taken by the owner to have a thorough overhaul of the various parts which may require attention, so that the best running and enjoyment free from all but minor troubles may be obtained during the best of the spring, summer, and autumn months. The wise man sees to it that all little details are gone into thoroughly, and he then derives the maximum of pleasure with the minimum of trouble.

The Putting-on Tool.

A manufacturer describes a very smart jig in use at his works, which has earned the nickname of "the putting-on tool," and is chiefly used in the repair shop. For instance, a car that has been in use a long time comes in for repair. Among other signs of wear and tear, it is noticed that, say, a small pinion or cam rocks on its shaft, that is, a loose fit. This at first sight appears a big job, but is easily done with the "putting-on tool," or in other words, by shrinking the hole smaller. The modus operandi is as follows: Take a rod of steel or iron that is a loose fit in the hole, and, using this as a

mandrel, heat the cam on it. When the cam is sufficiently hot, spray cold water on the outer surface of the cam, with the result that the hole will be reduced between 0.1 and 0.2 mm. This process may be repeated indefinitely, and may be applied to all sorts of parts, such as a nut that is loose on its thread, which is a very bad feature, even if a split pin is used. Any loose nut may be made tight by merely applying the "putting-on tool," and if satisfaction is not obtained from the first application, take another dose of the same physic, and there will be a further shrinkage of 0.1 mm.

Removing the Engine from the Frame.

To do this, first disconnect all wires, ignition rods, inlet, exhaust, and water connections, also the pump when it is removable and attached to the engine case, or any other bracket which prevents the ready removal of the engine. Always mark all the parts with a center-punch, letter, or number stamps to facilitate reassembling; note the length of any adjustable rods, so that there will be no alteration in these when again put in place. Mark with a sharp tool the exact position of the engine brackets on their bedding, in case the securing bolts are slack.

Having got the engine out, after removing the securing bolts, carefully clean all grease and dirt from all the outer parts of it which are accessible. Get a box to put in all the parts which are to be taken down, so that they may all be kept together and to save hunting for them later on. Securely fix up the engine on a bench or strong box, so that it can be operated on readily. Take out the sparking plugs to prevent breakage, and plug up the holes in which they screw either with corks or with a wad of clean cotton waste. Remove the valve covers or caps, then take out the valves by releasing the valve spring, taking out the valve cotter, and, either by jerking up the valve with one hand and catching it with the other or by a pair of pliers, take hold of a small piece usually turned on the valve head for grinding-in purposes, and pull out the valve.

Owing to the strength of the valve spring, and often to

the inaccessibility of it, difficulty is experienced in compressing the spring so as to allow of the removal of the small cotter which engages in the valve stem below the spring cup. The simple tool illustrated renders this operation quite easy. An

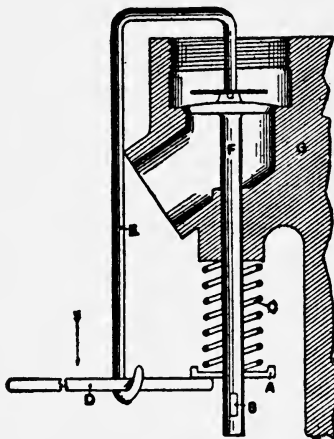

A simple device for removing valves.

- A, valve spring cup.
- B, valve cotter.
- C, valve spring.
- D, hand lever of $\frac{1}{4}$ in. diameter steel wire flattened at end under cup A.
- E, bent wire.
- F, valve.
- G, cylinder.

ordinary piece of steel wire a quarter of an inch in diameter can be bent as shown, the length being arranged to suit the depth of the valve. A disk of metal can be riveted to the wire where it presses on the valve head, or the wire itself can be bent round to form a circular head. When the lever D is depressed by the hand the spring cup A is raised, and the cotter B can be withdrawn, as the pressure on the top of the valve by the cramp E holds the valve securely on its seating.

Grinding in a Valve.

Examine the valve, and if found pitted or only bearing on part of the seating so that there has been a blow past, then the valve must be ground in. To do this, use a mixture of fine emery powder and lubricating oil, apply a little with the finger to the valve face, then put the valve in its place, and by means

of a screwdriver or a special screwed grinding-in tool partially rotate the valve backward and forward on its seating, meanwhile applying moderate pressure to it. Occasionally lift the valve and move it round to another position, and repeat the grinding until, on wiping away the emery and oil with a clean cloth or waste, a bright surface is seen all round the valve and the seating on which it beds when in position. If not worked down properly, repeat the operation until it is, applying more emery and oil; if the seating tends to dry up during grinding, just touch it with a little oil only if there is plenty of the emery powder on. Be careful not to press down too hard in grinding-in, or to get any grit or filings mixed up in the grinding mixture, as, if so, rings or ridges will be formed which probably can only be removed by turning up in a lathe.

After grinding-in and thoroughly cleaning the seatings, make sure, when the valve is placed back in position, that it comes right down on to its seating, and yet leaves a small space (usually about $1/32$ inch) between the valve spindle and its tappet rod when the cam is in such a position that the valve should not be lifted. If the grinding of the valve has dropped it so that its stem will not clear the tappet rod, it must be made to do so by filing a small amount from the top of the tappet rod. Do not file the valve stem, otherwise standard valves would be too long in the stem if a replacement were required at any time. If the valve is very badly pitted, or the head does not appear true with the stem, or if the neck under the head has burned to a much smaller section, which happens after a time with the exhaust valve, then the valve should be replaced by a new one, which should be ground in place to make a compression-tight seating. Replacing a valve in time will prevent trouble from breakage later on. There is always the danger, if the head should break off, that it may get in the cylinder and cause damage to the piston or other part. Remember, "a stitch in time saves nine."

Valve Spring Testing.

The inlet or exhaust valve springs may either have lost some of their elasticity and power, owing to the heat to which

they have been subjected, or in the case of automatic inlet valve springs, the constant rapid vibration may have permanently shortened them, thus preventing the rapid working of the valve on its seating. These should be renewed before going farther. It is always best to keep a new inlet and exhaust valve spring as a standard with which to compare the used springs, so that any deterioration can be detected at once.

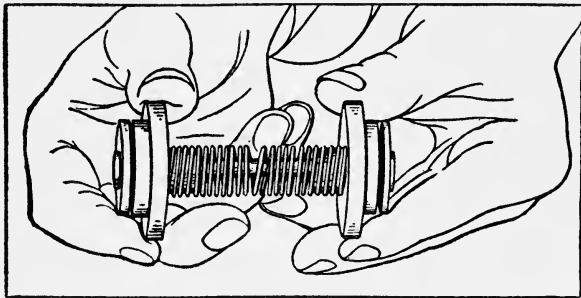

Testing an inlet valve spring against the standard. Note that both valves open at exactly the same moment.

With automatic inlet valve springs it is necessary to keep them always at the strength to give the best results, and so every spring fitted should be tested against the standard. This can be done by having a spare valve and seating fitted up with the standard spring complete, then press the stem of its valve against the stem of that to be tested, when it is likewise similarly fitted up. If correct, both valves should open exactly at the same moment, as the pressure tending to lift them from their seat will be equal. If the refitted spring is too strong, then shorten by nipping off a little with the pliers; if too weak, pull out carefully a little to strengthen it.

Marking of Camshaft Gears and Setting of Valves.

Valve setting appears to be a difficult subject with a large number of automobilists, but it is really the easiest of operations if the Otto cycle is understood. If the following instructions are carried out the veriest tyro will successfully manage this interesting job. In the first place the flywheel should be rotated until the piston is brought to the top of its

stroke. In two or more cylinder engines the forward piston is meant. This can be ascertained either by inserting a long piece of stiff wire through the compression tap hole, the sparking plug hole—when it is in the top of the cylinder—or by noting the position of the crank through the inspection lid of the crank chamber.

Now notice whether both inlet and exhaust valves are down on their seatings. If so, oscillate the flywheel backward and forward through a small arc, and if in one direction the inlet valve is lifted from its seating, and in the other the exhaust valve is lifted, you are then ready for the next proceeding.

The cams would occupy the position shown in the sectional sketch, the induction stroke being just about to commence. If the valves do not lift as stated, then the flywheel must be turned through one revolution.

The inlet valve will open immediately the exhaust valve closes, and close about the end of the suction stroke. The exhaust valve will open a little before the end of the working stroke. This time of opening varies from $\frac{1}{4}$ inch to $1\frac{1}{4}$ inch from the end, according to the make of engine, length of stroke, and speed at which it is desired to run.

Now, if the camshaft wheels are not cased in—as in some types they are not—you can proceed to mark the wheels as shown in the sketch, using either a sharp scribe, or center-punch the corresponding tooth and metal below the space in which the tooth gears. If the wheels are cased in, then lay the whole engine flat on the flywheel, using two blocks of wood below the wheel if necessary, as it may be if there is any projecting clutchshaft. Take out the screws, or remove the securing nuts which hold the gear cover plate in position, and carefully lift off the plate, so that the wheels are left in position and in mesh without disturbance. Again make sure that the piston is at the top of its stroke, and mark the wheels. In some cases it may be necessary to remove the contact maker bodily before the cover plate can be taken off. If the center piece is keyed in position, it must be gently forced off with a steel wedge or bent lever.

Before removing the camshaft, the valve tappets should be so secured that they cannot drop down and so foul the cams

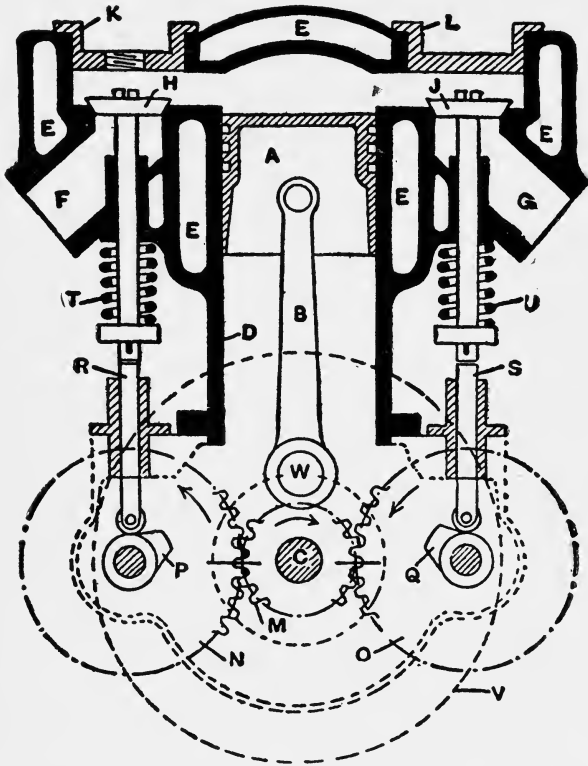

Sketch showing how to set the valves. Note the two marked points on the wheels M, N, and O.

- | | |
|--|---------------------------------------|
| A, piston. | L, exhaust valve cap. |
| B, connecting rod. | M, gear wheel on C. |
| C, crankshaft. | N, inlet valve camshaft gear wheel. |
| D, cylinder. | O, exhaust valve camshaft gear wheel. |
| E E E, water jacket. | P, inlet valve cam. |
| F, inlet port. | Q, exhaust valve cam. |
| G, exhaust port. | R S, valve tappet rods. |
| H, inlet valve. | T U, valve springs. |
| J, exhaust valve. | V, flywheel. |
| K, inlet valve cap tapped for sparking plug. | |

and prevent withdrawal of the shaft. A thin bit of twine tightly tied round the tappet stem when it is lifted up as far as it will come suffices.

Taking off the Cylinders.

The next operation is to take off the cylinders. Slack off the nuts which secure the first cylinder flange to the crank case, then gently lift the cylinder until the piston can be seen. Rotate the flywheel until the piston comes to its lowest point, so that there is not far to pull up the cylinder. Allow the connecting rod to rest on one side of the crank case, so that when the cylinder is pulled entirely away from the piston the latter will not fall against the rod and have a piece knocked out of it. Repeat the above for the remaining cylinders; note whether there has been any blow past the rings. If so, these should be renewed if plain slit across, but if tongued they may be used again when ground with pumice powder and oil in place in the cylinder, if there is sufficient spring in the rings to force them outward to a larger diameter than the piston.

To detect a leakage or blow past the rings, it will be found that, instead of the rings being perfectly bright and smooth all around, they will show black at some part of the circumference, both on the rings and the piston, where the blow past has taken place.

Next soak the cylinders well in turn in a bucket containing clean kerosene. This will remove all the dirty oil, and also loosen any deposit of charred lubricating oil, so that it can easily be removed from the combustion chamber by means of a scraper or a file end.

The next thing is to try whether the piston pin is loose in its piston bearing hole, as may sometimes be the case. An objectionable knocking is caused by a loose piston, this somewhat resembling that caused by having the ignition advanced too far. Hold the piston in one hand, and the connecting rod in the other, and try to rock or twist the piston backward or forward at right angles to the pin. If the pin moves in the piston, a tighter one should replace it. This will have to be turned up in a lathe, preferably from a bar of good cast steel, and then fitted up tightly in the piston, care being taken that the ends of the pin are slightly below the diameter of the pis-

ton, otherwise scoring of the cylinder may take place on re-suming work.

Taking down Piston and Rings.

This is the point where trouble will be found if care is not taken. First remove the securing screw or ring which holds the piston pin in position, then gently tap out the pin with a piece of soft copper or hard wood. An extra hand is required to hold the piston while this is being done. Now, having the piston free, the next thing is to remove the rings. This may be a troublesome job, but if rightly tackled is very easy. Figs. 1 and 2 show the first and second operations of removing the last ring, which is the most difficult when it has to be slipped over the grooves from which the other rings have been removed. The tools required are three strips of thin tin, $\frac{1}{4}$ or $\frac{3}{8}$ inch wide, and of a length proportionately as shown; a pair of tongs made of $\frac{1}{4}$ inch diameter steel wire, tied up with copper wire to form a hinge, so that the end away from the hand opens instead of shuts when the tongs are gripped (just the opposite to ordinary pliers); and a pair of hands. Commence by opening out the rings slightly as shown in Fig. 1, insert a piece of tin between the ring and the piston, loose the tongs, and then take hold of the tin above and below the ring, and slide the tin round to the opposite side of the slit. Next insert another piece of tin in the same manner, and also a third, leaving them in the positions as shown by Fig. 1. Now take hold of the ring as shown by Fig. 2, pressing with the thumbs on the top of the piston, and the ring will slide easily off. With this method the fingers are not cut or pinched, the ring is not broken or distorted from its circular shape, and the time occupied is not a tithe of that required without this simple device.

Wearing and Renewal of Piston Pins and Bushes.

Having cleaned the piston pin free from oil, examine it, and notice whether there is excessive wear on the part which fits in the bush of the connecting rod end. This will be indicated by a ridge at each portion of the pin next to the inside

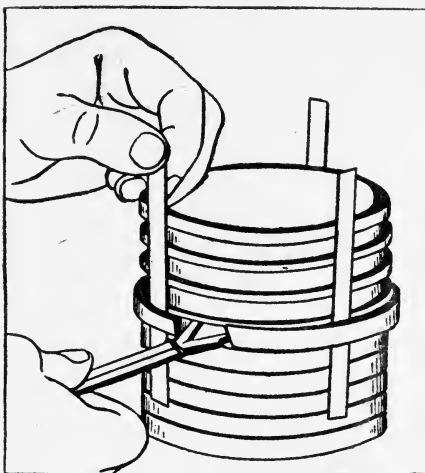

Fig. 1

First operation in taking off a piston ring. Opening it out with special tongs to insert the tin guiding strips.

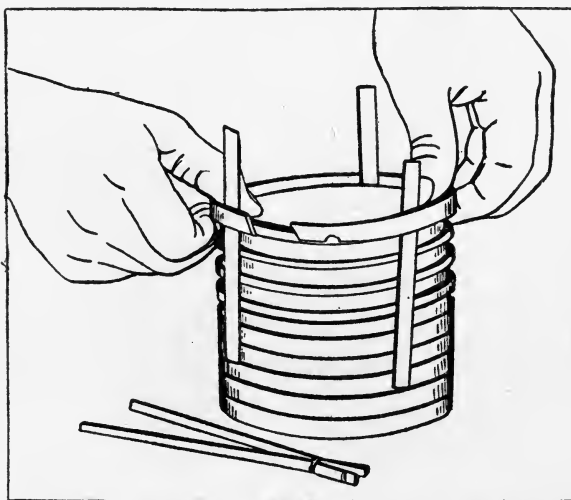

Fig. 2

Second operation of taking off a piston ring. Slipping it off over the tin strips.

bosses of the piston. The pin will be worn more on one side than the other, namely, the lower side, on which the full force of the explosion pressure on the piston top is felt. If not more than $1/64$ inch of wear has taken place at this part of the pin and it is also a fit, as before described, in the piston, then the pin may or may not be renewed. The bush in which the pin works may, however, be worn and require renewal. Try the pin in the bush in its working position, and feel whether it has more than $1/64$ inch play in it. If so, a new bush should be obtained from the makers of the car or their agents, and this will require pressing home in the connecting rod end to take up exactly the same position as the old one.

To remove the play in the case of split brasses, it will be necessary to remove the securing bolts, and then file a little off the flat face of the cap and the brass. Do this a little at a time, and make trials with the cap tightened up in position, to find when sufficient metal has been removed from the cap face and brass. When no play is noticeable, and the rod is still free on the crank pin, the job may be considered satisfactory. There should be no necessity to scrape the brasses, unless they are badly scored through want of oil or through access of grit.

In the case of solid bushes, such as are used on built-up cranks, then excessive wear means either a new bush or, if possible, lining up the old one with a good anti-friction white metal. This is a job that requires some skill and experience, and should be undertaken by the makers of the engine, who would do all the work required if the exact worn size of the crank pin were supplied to them.

The same remarks apply to the main bearings of the engine as for the crank pin bearings; they can be tried in the same manner by holding the crank case and feeling the crank for play.

Scraping up and Adjusting Engine Bearings.

Some amateurs may wish to scrape up the brasses of the connecting rod end of the main crank bearings, and although

they may not make as good a job of them as a professional man, a few words on the subject may be useful. The first thing to do is to make a scraper suitable for the job. This can be made out of an old, worn smooth, half-round file about 6 to 8 inches long. The file will require softening, and the cross cut marks ground entirely out of it on the flat face, and on the back edge; after this it should be heated to a dull red heat and bent slightly back, the rounded part of the file being on the inner side of the bend. After this the file requires hardening, preferably in oil, and then grinding up to make two cutting edges. These will not be smooth enough to scrape brasses, and will require further smoothing on an ordinary carpenter's stone, which will remove the roughness and put on a fine cutting edge. The object of bending the file is so that the hand, in grasping the file handle, may be able to operate at an angle with the brass, and also that any particular hard point in the brass can be reached without taking metal away from the easier contact portion, the circular shape of a cutting edge rendering this easy to do. Having made the brasses fairly tight on the bearings by filing a little away from the caps, all that remains is to bed the brasses properly on their bearings.

To do this, a very small amount of red ocher mixed with lubricating oil should be lightly smoothed over the crank pin bearing, only the slightest trace being left on after the ocher has been spread over the whole surface of the crank bearings uniformly; then put on the connecting rod, slightly tightening up the nuts and working the connecting rod round. On removing the cap it will be found that some parts of the brasses will be harder than others. Probably the bearing will be shown by dark lines extending in a ring round the brasses. These dark lines require easing by means of the before-mentioned scraper. To do this, take hold of the flat edges of the brasses in a vise so that any squeezing up of the vise will not tend to buckle or close the halves, as holding in the opposite direction would. Now carefully, with the scraper handle in the right hand, and with suitable pressure on the

scraper close to the handle with the left hand, try and scrape the hard surface from the brass.

How to Work up a Bearing.

It will possibly be found that a difficulty is experienced in taking the metal off evenly, the scraper showing a decided tendency to dig in and create holes where not wished for. This can be avoided by scraping slightly with one cut, and practically at nearly a right angle with another cut, thus the scraper bridges over the notches or holes made by the first cut. Of course, experience is necessary to do this work nicely, and one cannot expect to compete in the matter with a man who has had years of experience in it. Continued trial will enable one, however, to approach somewhere near a good surface. Care must be exercised that the brasses are not left hard on the sides close to the split, otherwise there will be a tendency to bind when the bearing gets warm. They should always be left slightly easier at the side than at the top and bottom, where the greatest thrust is obtained.

When it is finally considered that the bearing is good enough, as indicated by a contact well over the brasses, the connecting rod bolts should be tightened up hard, and the connecting rod should then be freely movable about the crank pin without any play being felt. At the same time, a straight-edge should be tried up the side of the crank cheeks, and this should be found to be exactly perpendicular to the piston pin hole. A set square placed clean through the piston pin hole along the bottom, and the foot of the square slid out to meet the straight-edge will at once show whether this is so, as, if correct, the foot of the straight-edge should be exactly parallel to the edge of the straight edge.

The same mode of procedure as regards scraping the brasses and trial for easy working fit without end play should be adopted with the main crank bearings. If any of the journals are found to be scored, they can be smoothed with a piece of fine emery cloth, this being rubbed round the bearing shaft backward and forward, by taking hold of each end of the

emery cloth and working it backward and forward until a smooth surface is obtained.

Examination of Parts and Reassembling the Engine.

Now carefully examine the bolts which secure the flywheel to the crank, and notice whether any of these are at all loose, as if so they must be thoroughly tightened up and secured by split pins. It is hardly likely that there will be very excessive wear on the crankshaft pinion, which actuates the half-time wheels, as in a properly designed engine the wear and tear at this point are not such as to require frequent renewal of the part. Thoroughly examine every other detail making up the engine, and clean free from oil or any dirt. A good washing through with kerosene removes all grit and any extraneous matter. The reassembling of the engine requires careful attention, as on this entirely depends the success or otherwise of the overhauling. Every part should be replaced exactly as found, and care must be taken to lubricate all bearings, piston rings, valve spindles, camshaft bearings, cams, rollers, and guides, and above all, every nut must be properly secured, as if a single split pin is left out, or if put in place and left unopened, a breakage sooner or later is sure to follow, which means great expense to remedy. On reassembling the engine, the timing of the valves can be performed as already described and illustrated, and after putting the engine together as specified, it may be put on one side ready for again placing in the car when the other parts have received attention.

Overhauling the Gear Box.

If the bearings are found not to be excessively worn, and also the gear wheels and strikers are in fair condition, the only thing that need be done to the gear box is thoroughly to clean out the grease and oil, then wash through with kerosene, and finally lubricate all the bearings, and put in the box the requisite quantity of oil and grease which experience has shown the owner to be necessary. If it is found that the bearings are too slack, then the same course must be adopted

as with the crankshaft bearings, although it may only be necessary to take off the top half of the case, leaving the bottom in position on its supporting frame; the bearings can then be taken off and worked up in a vise, if split bronze bearings are used. If plain bush bearings are fitted, these will have to be removed or relined with metal. If the gears are badly worn, and, say, a quarter of the tooth has been ground away through gear changing, then it is necessary to renew the particular wheels which are worst worn. It is usually cheaper and quicker to get these from the firm supplying the car, as they should in every case be absolutely interchangeable; and all that is required to secure them in place is to take off the old wheel, put on the new, and bolt or rivet it up in position.

On receipt of any new part from a manufacturer or agent, it should always be checked over with the old, so that mistakes cannot occur, as where a number of types of cars are sold by the same firm, and also when these are altered from year to year, some confusion may ensue in obtaining spare parts.

The Differential Gear and Live Axle.

An important part of the machine to examine in overhauling is the differential gear, to see whether this has worn excessively, or excessive play has appeared in the pins carrying the planet wheels. This can best be done by jacking under one end of the axle, inside or under the spring, so that the road wheel on that side is free from the ground, then, by taking hold of the spokes of this wheel and gently rocking it to and fro, the amount of play between the gear wheels and the main driving-shaft in the gear box can be ascertained. Of course, this play will be made up from a number of parts in a live axle drive; the first amount of play that will be found will be between the center pinions of the differential gear and the planet pinions. The next amount of play will be between the large bevel and its small bevel, which is attached to the propeller-shaft. Then next the shaft joints, which are nearly always found to contain a fair amount of play, and finally

through the direct drive there may be further play between the gear-box and the clutch sleeve.

As a rule, differential gears are now made so that very little play is obtainable in them even after a good many thousands of miles running, and generally the most excessive play is found between the two bevel pinions and in the universal joints. The smaller driving bevel pinion in some cases can be adjusted by the deeper engagement with the larger; this operation can usually be performed from the outside, an adjusting cup and locking ring being fitted. In other cases, a ball-thrust ring is used, no adjustment being supplied in this; also possibly a plain bearing with a collar is fitted, so that in the two latter cases, if adjustment is required, a washer must be inserted to make up for the play found.

It is not necessary to take a back axle down if there is not found to be excessive play in the inside parts; the only thing to do is to run out all the grease and oil, wash through with kerosene, and after replacing the plug usually fitted to the case bottom for the removal of dirty oil, refill with a mixture of clean oil and thick grease. If the propeller-shaft joint pins or blocks are found to be much worn, these can be renewed for a fairly small sum. In a number of cases the size of the joints is not at all proportionate to the power which has to be transmitted through them, and therefore they are constantly giving trouble by excessive wearing of the pins. When these pins become loose, the noise from them is very objectionable, a constant knocking being noticed, which is not only bad from the silence standpoint, but is also very bad for all the transmission gear, as it is always desirable to run this without any knock to insure a sweet running car.

In the case of a chain-driven car, the chains should be removed and thoroughly soaked in clean kerosene to remove all the dirt, after which they should be placed in melted fat or tallow, so that all the joints can be permeated with this, then, after they have been thoroughly soaked in it, if taken out and allowed to cool, a thin film of fat is left in every joint, and the chains work very well when replaced. To keep the dirt

from a chain, amateurs will often find very successful results from fitting a thin metal shield above and below the chains, as in this way the dirt thrown from the road wheels is directed away from the chains.

Examination of Ball Bearings, etc.

While the front wheels are jacked up for overhauling the ball bearings or plain bearings can be tried for wear; the ball races, where fitted, can be adjusted if necessary, care always being taken to leave a little play, otherwise breakage of some of the balls is sure to follow. Be very careful to lock up the cones with the locking devices provided, or when running the wheel cone may either unscrew or tighten up, with disastrous result. For a plain bearing, if excessive wear is found, the hub will require rebushing, this operation being best performed either by a local repairer or by the makers of the car. Usually, when such an operation is required, there are other parts of the car which require attention, so that a good thing to do is to send it to the repair shop with a list of things requiring attention, and the lot can be done at once.

Examination of Wheels and Tires.

Each of the wheels should be overhauled in turn, special attention being paid to the joints at the hub flanges and also where the spoke enters the felloe. If a wooden wheel has been built up with partly-seasoned timber, it is rather likely to shrink and the spokes to become loose at the nave. In this case, the bolts binding the two flanges together and gripping the spoke centers should be well tightened; the rear wheels are the ones which usually give trouble in this respect, because with these the driving strain is taken through them to the tire. Of course, the effect in this case is to pull out the spokes tangentially also, as there is considerably more side stress on the rear wheels in turning a corner. Owing to the greater distribution of weight for driving purposes on these wheels, they are or should be made stronger than the front wheels. If the paint happens to be disturbed at the joints, it does not

follow that the spoke is loose, but the precaution should always be taken of feeling the nut and trying whether it can be tightened up further with a spanner without straining the bolt.

Next, the tires should be examined for cuts or perishing of the rubber, the latter being usually indicated by cracks at the sides of the outer casing. At the end of a season's running it is advisable to take off each of the tires in turn and examine, to see that no dirt or other erosive substance has worked between the outer cover and inner tube, as after some time this invariably rubs a hole in the inner tube. If the tires are sound, and they do not appear to be badly worn, they can be at once replaced, care being taken either to lightly rub the inner part of the casing with flake graphite or with plenty of French chalk, so that when heated through running the inner tube will not stick to the casing. If the canvas should show signs of rotting through the penetration of damp or wet, the cases may be returned to the makers or agents for examination and repair; also if the tread is worn very thin, or is badly cut in a number of places, the makers should have the casing to vulcanize on it another tread, which, of course, will last for several thousands of miles running.

In the case of small cuts, these may possibly be patched up by the owner. To do this, the cut should be well cleaned out by dabbing inside it with cotton-wool moistened with gasoline. This clears away the dirt, and also makes the rubber tacky; then if the cut is very large, a wedge of good rubber previously treated with rubber solution and allowed to get tacky should be inserted in the cut. Before putting in the wedge, the cut should also have received a dressing of the solution after the dirt has been cleaned away with the gasoline-damped wad. In case of blistering of the tires, this is usually due not to dirt picked up from the road, as a number of people imagine, but to internal friction between the canvas and the rubber of the casing. The makers are the best people to treat defects of this nature. If it is necessary to replace the tires by new ones, it is always advisable to fit the largest possible section of tire that the rim will take.

Electrical Items.

Where magneto ignition is used, the magneto does not usually require attention; with low tension the strikers in the cylinder may require slightly touching up where they are worn, or even may require replacing by new ones. In the case of batteries, these should be examined, and where a brown powder or any particles of paste are found inside the case the acid should be emptied out into an earthenware vessel, and the battery well washed out with clean rain water, so that all the particles can be removed through the ventholes. If plates are buckled or the paste has dropped out in several places, the battery should be returned to the makers or agents for overhauling, as this is a job not readily performed by the amateur. If, before taking down the car, the coil and commutator have worked satisfactorily, these should not be touched, as when a part is working well, beyond the usual periodical attention which all mechanism requires, it should not be overhauled just for the sake of doing so. Usually the only trouble with a good induction coil is that due to cleaning and adjustment of the trembler screw, a fine bit of emery cloth and a file being used to remove any excrescence which may be formed upon the platinum point, the adjustment of the trembler being completed when the commutator is making contact on its metal wire. Usually the sound given off from the trembler is an indication as to when it is correctly set, although this may be verified by laying the sparking plug on the metal cylinder and examining the spark obtained at its points in the usual way when all the connections are made. The wiring system should be examined, and wherever a wire is chafed or the insulation damaged it should be renewed.

Attention to Brakes and Details.

The countershaft and rear wheel brakes should be examined, and if the interior lining, which in some cases consists of belting or a thin casing of metal (often cast or wrought iron), be worn badly it should be renewed. For internal expanding brakes, the metal parts in rubbing contact should be ex-

amed, and if worn thin they should be renewed. Care should be taken in adjusting up these brakes after taking down and renewing, so that when on the road an even pull is imparted to both the drums, otherwise there is sure to be a tendency to skid the car. The final adjustment of the brakes can only be effected when tested on the road. In the case of a brake fitted with removable shoes, there is not such great difficulty in replacing these, as usually all that is necessary is to remove a couple of bolts, when the brake shoe will come away and can be immediately replaced by a new one. It is needless to say that in replacing the parts care must be exercised to see that all split pins are renewed and properly opened out, otherwise there is danger of some part coming adrift on the road.

All the tanks, radiator, and any part where there are joints that may require packing, such as the pump, gland, etc., should receive attention; also any small joints wherein the holes are badly worn should be overhauled and the necessary work done to them to take out any backlash, as the accumulation of backlash in various parts of the mechanism causes a considerable amount of rattle. The components of the whole rattle are really small, but when taken together constitute quite a formidable noise.

If there are any rents or breakages in the upholstery of the car, these should receive attention at the hands of a coachbuilder. A coat of varnish on the body and other parts very considerably improves the appearance, if done properly by a coachbuilder.

Some unimportant points may have been omitted, but in going over a car the owner will no doubt have noticed these, and will have remedied them where desired. If the general instructions given are correctly interpreted, every satisfaction should be experienced in the continued use of the car when all the parts are reassembled exactly as taken down.

The Thompson Series of Home Study Books

Books that not only TELL you how to do things
But SHOW you how

AUTOMOBILE TROUBLES AND HOW TO REMEDY THEM --- By Charles P. Root, Former Editor of *Motor Age*. 225 pages, fully illustrated, round corners, pocket size, red edges. A practical book for Automobile Owners, Drivers, Repairmen, intending purchasers and all those interested directly or indirectly in Motor Cars. Overhauling and general repair of the car is taken up and discussed at length. A book that not only tells you how to locate trouble and make repairs but shows you. The only book of its kind published. Price, Flexible Leather, **\$1.50**. Cloth..... **\$1.00**

AUTOMOBILE DRIVING SELF-TAUGHT---By Thomas H. Russell, M. E. LL. D., Former Editor of *Modern Machinery*, Editor of the *American Cyclopedia of the Automobile*, Author of the *History of the Automobile*, *Automobile Motors and Mechanism*, *Ignition, Timing and Valve Setting*, *Motor Boats: Construction and Operation*, etc. 230 pages, liberally illustrated, round corners, pocket size, red edges. An exhaustive treatise on the operation, management and care of Motor Cars. Handling the car on the road under all conditions, making repairs, and locating faults are treated in a thorough manner. The hints on management of cars would be worth many times the price to beginners. Price, Flexible Leather, **\$1.50**. Cloth, **\$1.00**

AUTOMOBILE MOTORS AND MECHANISM---By Thomas H. Russell, M. E. LL. D., Author of *Automobile Driving Self-Taught*, *Ignition, Timing and Valve Setting*, *Motor Boats: Construction and Operation*, etc. 265 pages, round corners, red edges, pocket size, fully illustrated. A practical illustrated treatise on the power plant and motive parts of the modern motor car, for owners, operators, repairmen, and intending motorists. Price, Flexible Leather, **\$1.50**. Cloth, **\$1.00**

IGNITION, TIMING AND VALVE SETTING---By Thomas H. Russell, M. E. LL. D., Author of *Automobile Motors and Mechanism*, *Automobile Driving Self-Taught*, *Motor Boats: Construction and Operation*, etc. Fully illustrated, 225 pages, round corners, pocket size, red edges. A comprehensive illustrated manual for self-instruction for automobile owners, repairmen and all interested in motoring. Price, Flexible Leather, **\$1.50** Cloth,..... **\$1.00**

MOTOR BOATS: CONSTRUCTION AND OPERATION---By Thomas H. Russell, M. E. LL. D., Editor of *The American Cyclopedia of the Automobile*, Author of *The History of the Automobile*, *Automobile Driving Self-Taught*, *Automobile Motors and Mechanism*, *Ignition, Timing and Valve Setting*, etc. 300 pages. An illustrated manual for motor boat, launch and yacht owners, operators of marine gasoline engines and amateur boat builders. Intended principally for the man who is not a mechanic. Its purpose is to provide a compendious guide to the design, construction, installation and operation of marine motors and to the design and construction of motor boats. Price, Flexible Leather, **\$1.50** Cloth,..... **\$1.00**

A B C OF THE MOTORCYCLE---By W. J. Jackman, M. E. Author of *Facts for Motorists*, *Crushed Stone and its Uses*, etc. Former Editor of the *Chicago Daily Journal*. Liberally illustrated, 250 pages, round corners, red edges, pocket size. A book of practical information for men who use motorcycles. It describes the mechanism and operation of the motorcycle so plainly that any man of average intelligence can understand it, regardless of mechanical training. It is the one practical book that really **shows** you how and should be read by every man who uses a motorcycle. This book shows how you to remedy road troubles almost instantly. Price, Flexible Leather,..... **\$1.50** Cloth,..... **\$1.00**

FLYING MACHINES: CONSTRUCTION AND OPERATION --- By W. J. Jackman, M. E. Author of *A B C of the Motorcycle*, *Facts for Motorists*, *Crushed Stone and Its Uses*, etc., and **Thomas H. Russell, A. M., M. E.** Charter Member of the Aero Club of Illinois, author of *History of the Automobile*, *Motor Boats: Construction and Operation*, etc. With introductory chapter by **Octave Chanute, C. E.**, President of the Aero Club of Illinois. Profusely illustrated, about 250 pages, round corners, red edges, pocket size. Just the book for those who want to know how to construct and operate gliders and flying machines. It "shows how" in both pictures and text. Price, Flexible Leather,.... **\$1.50** Cloth,..... **\$1.00**

These books are written in plain, simple, every-day language, fully illustrated with especially prepared drawings, diagrams and illustrations that show you how. Sold by Booksellers generally, or sent postpaid on receipt of price.

CHARLES C. THOMPSON COMPANY,

1126-28 S. Wabash Avenue, Chicago

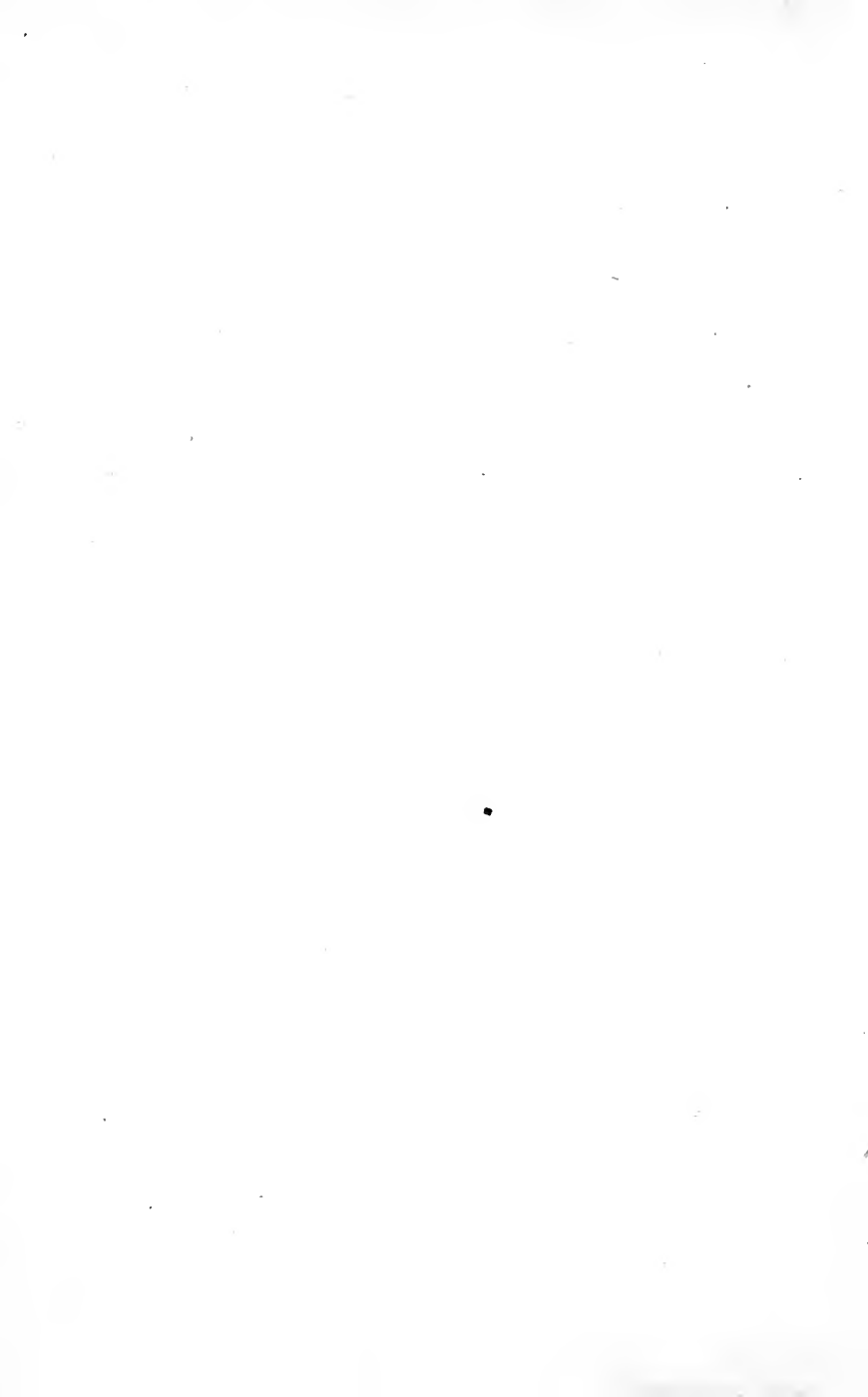

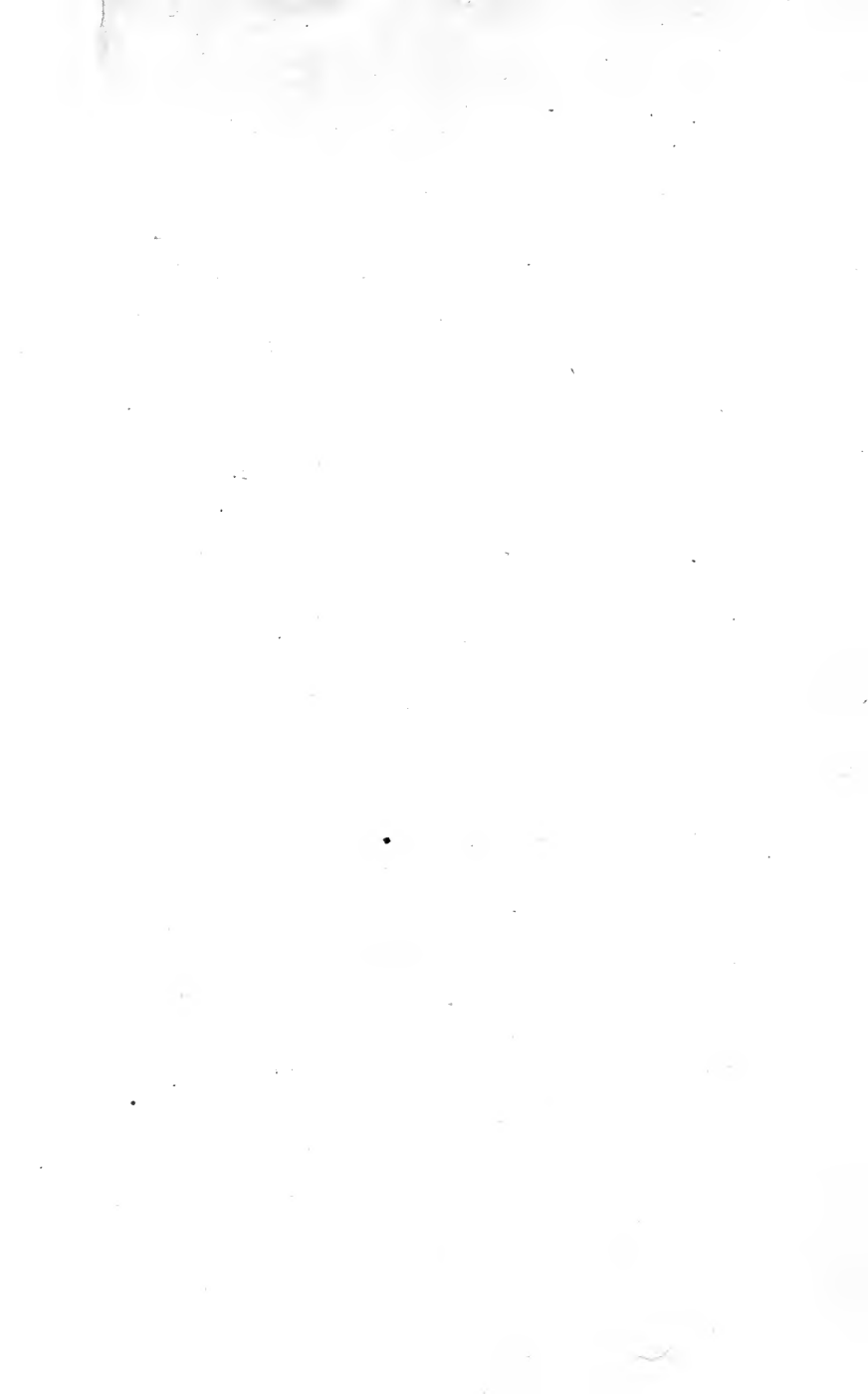

14 DAY USE
RETURN TO DESK FROM WHICH BORROWED

LOAN DEPT.

This book is due on the last date stamped below,
or on the date to which renewed. Renewals only:

Tel. No. 642-3405

Renewals may be made 4 days prior to date due.
Renewed books are subject to immediate recall.

R

MAY 17 1971 4 7

REC'D LD MAY 17 71 -3 PM 8 5

REC'D LD OCT 6 '71 -3 PM 9 8

JAN 15 1986

REC. CIR. OCT 1 5 1986

AUTO DISC FEB 0 4 1990 APR 04 1990

LD21A-50m-2,'71
(P2001s10)476-A-32

General Library
University of California
Berkeley

LOAN DEPT.

LD 21A-50m-8 '61

JAN 2 1970 General Library

YC 19402

GENERAL LIBRARY - U.C. BERKELEY



8000927950



46

TL 200

R7

1911

250474

Root

