



Marine Biological Laboratory Library
Woods Hole, Massachusetts



Gift of Douglas Marsland - 1978

Buggar

↓

Packard

↓

Marshall

MBL/WHOI



0 0301 0013200 7



BIOLOGICAL EFFECTS OF RADIATION



VOLUME II

COLLABORATING EDITORS

JANET HOWELL CLARK, Associate Professor of Physiology, School of Hygiene and Public Health, The Johns Hopkins University, Baltimore

KENNETH S. COLE, Assistant Professor of Physiology, College of Physicians and Surgeons, Columbia University, New York City

FARRINGTON DANIELS, Professor of Chemistry, University of Wisconsin, Madison

GIOACCHINO FAILLA, Physicist, Memorial Hospital, New York City

CHARLES PACKARD, Assistant Professor of Zoology, Institute of Cancer Research, Columbia University, New York City

HENRY W. POPP, Associate Professor of Botany, Pennsylvania State College, State College

BIOLOGICAL EFFECTS OF RADIATION

*Mechanism and Measurement of Radiation,
Applications in Biology, Photochemical
Reactions, Effects of Radiant Energy
on Organisms and Organic Products*

VOLUME II



EDITED BY

BENJAMIN M. DUGGAR

*Professor of Plant Physiology and Applied Botany,
University of Wisconsin*

WITH THE COOPERATION OF

JANET HOWELL CLARK

GIOACCHINO FAILLA

KENNETH S. COLE

CHARLES PACKARD

FARRINGTON DANIELS

HENRY W. POPP

FIRST EDITION

*Prepared under the Auspices of the
Committee on Radiation*

Division of Biology and Agriculture,
National Research Council, Washington

McGRAW-HILL BOOK COMPANY, INC.

NEW YORK AND LONDON

1936

COPYRIGHT, 1936, BY THE
MCGRAW-HILL BOOK COMPANY, INC.

PRINTED IN THE UNITED STATES OF AMERICA

*All rights reserved. This book, or
parts thereof, may not be reproduced
in any form without permission of
the publishers.*

CONTENTS

PAPER	PAGE
XIX. PHOTOPERIODISM <i>W. W. Garner</i> , Principal Physiologist in charge of Tobacco and Plant Nutrition, Bureau of Plant Industry, U.S. Department of Agriculture, Washington, D.C.	677
XX. PLANT GROWTH IN CONTINUOUS ILLUMINATION <i>John M. Arthur</i> , Biochemist, Boyce Thompson Institute for Plant Research, Inc., Yonkers, N.Y.	715
XXI. THE EFFECTS OF LIGHT INTENSITY UPON SEED PLANTS. <i>Hardy L. Shirley</i> , Associate Silviculturist, Lake States Forest Experiment Station, University Farm, St. Paul, Minnesota	727
XXII. EFFECTS OF DIFFERENT REGIONS OF THE VISIBLE SPECTRUM UPON SEED PLANTS. <i>H. W. Popp</i> , Associate Professor of Botany, Pennsylvania State College, State College <i>F. Brown</i> , Instructor in Botany, Pennsylvania State College, State College	763
XXIII. EFFECT OF THE VISIBLE SPECTRUM UPON THE GERMINATION OF SEEDS AND FRUITS. <i>William Crocker</i> , Managing Director, Boyce Thompson Institute for Plant Research, Inc., Yonkers, N.Y.	791
XXIV. THE EFFECTS OF VISIBLE AND ULTRA-VIOLET RADIATION ON THE HISTOLOGY OF PLANT TISSUES. <i>J. T. Buchholz</i> , Professor of Botany, University of Illinois, Urbana	829
XXV. SOME INFRA-RED EFFECTS ON GREEN PLANTS. <i>John M. Arthur</i> (see Paper XX)	841
XXVI. THE EFFECT OF ULTRA-VIOLET RADIATION UPON SEED PLANTS . . . <i>H. W. Popp</i> and <i>F. Brown</i> (see Paper XXII)	853
XXVII. THE EFFECTS OF RADIATION ON FUNGI. <i>Elizabeth C. Smith</i> , Research Assistant, University of Wisconsin, Madison	889
XXVIII. THE PROBLEM OF MITOGENETIC RAYS <i>Alexander Hollaender</i> , Research Associate (under auspices of National Research Council), University of Wisconsin, Madison	919

PAPER	PAGE
XXIX. EFFECTS OF X-RAYS UPON GREEN PLANTS	961
<i>Edna L. Johnson</i> , Associate Professor of Biology, University of Colorado, Boulder	
XXX. THE EFFECTS OF RADIUM RAYS ON PLANTS.	987
<i>C. Stuart Gager</i> , Director, Brooklyn Botanic Garden, Brooklyn	
XXXI. THE LIGHT FACTOR IN PHOTOSYNTHESIS	1015
<i>H. A. Spoehr</i> , Chairman, Division of Plant Biology, Carnegie Institution of Washington, Stanford University, California	
<i>J. H. C. Smith</i> , Staff Member, Division of Plant Biology, Carnegie Institution of Washington, Stanford University, California	
XXXII. THE INFLUENCE OF RADIATION ON PLANT RESPIRATION AND FERMENTATION.	1059
<i>Charles J. Lyon</i> , Professor of Botany, Dartmouth College, Hanover, N.H.	
XXXIII. GROWTH MOVEMENTS IN RELATION TO RADIATION.	1073
<i>Earl S. Johnston</i> , Assistant Director, Division of Radiation and Organisms, Smithsonian Institution, Washington, D.C.	
XXXIV. CHLOROPHYLL AND CHLOROPHYLL DEVELOPMENT IN RELATION TO RADIATION	1093
<i>O. L. Inman</i> , Director, Kettering Foundation for the Study of Chlorophyll and Photosynthesis, Antioch College, Yellow Springs, Ohio	
PAUL ROTHMUND, Research Chemist, Kettering Foundation for the Study of Chlorophyll and Photosynthesis, Antioch College, Yellow Springs, Ohio	
<i>C. F. Kettering</i> , Director of Research, General Motors Corporation	
XXXV. RADIATION AND ANTHOCYANIN PIGMENTS.	1109
<i>John M. Arthur</i> (see Paper XX)	
XXXVI. EFFECTS OF RADIATION ON BACTERIA	1119
<i>B. M. Duggar</i> , Professor of Plant Physiology and Applied Botany, University of Wisconsin, Madison	
XXXVII. THE EFFECTS OF RADIATION ON ENZYMES.	1151
<i>Harold A. Schomer</i> , Fellow in Botany, University of Wisconsin, Madison	
XXXVIII. INDUCED CHROMOSOMAL ABERRATIONS IN ANIMALS.	1167
<i>Theodosius Dobzhansky</i> , Assistant Professor of Genetics, California Institute of Technology, Pasadena	
XXXIX. RADIATION AND THE STUDY OF MUTATION IN ANIMALS	1209
<i>Jack Schultz</i> , Research Assistant, Carnegie Institution of Washington, California Institute of Technology, Pasadena	

PAPER	PAGE
XL. INDUCED MUTATIONS IN PLANTS. <i>L. J. Stadler</i> , Senior Geneticist, Bureau of Plant Industry, U.S. Department of Agriculture, and Professor of Field Crops, Uni- versity of Missouri and Agricultural Experiment Station, Columbia	1263
XLI. INDUCED CHROMOSOMAL ALTERATIONS <i>T. H. Goodspeed</i> , Professor of Botany and Director Botanical Garden, University of California, Berkeley	1281
XLII. INDUCED CHROMOSOMAL ALTERATIONS IN MAIZE. <i>E. G. Anderson</i> , Department of Biology, California Institute of Technology, Pasadena	1297
XLIII. BIOLOGICAL ASPECTS OF THE QUANTUM THEORY OF RADIATION ABSORPTION IN TISSUES <i>John W. Gowen</i> , Associate Member, Department of Animal and Plant Pathology, The Rockefeller Institute for Medical Research, Princeton	1311
SUBJECT INDEX	1331
ALPHABETICAL LIST OF CONTRIBUTORS	1343

XIX

PHOTOPERIODISM

W. W. GARNER

U. S. Department of Agriculture, Bureau of Plant Industry, Washington

Introduction. Discovery of the length-of-day effect. Long-day and short-day plants. Flowering and fruiting responses. Growth relations. Formation of tubers, bulbs, and thickened roots. Senescence, dormancy, and related phenomena. Morphological and anatomical effects. The photoperiodic aftereffect (photoperiodic induction). Supplementary artificial illumination and continuous light. Interrelationship of other environmental factors. Effects of abnormal light periods. The photoperiodic response and heredity. Photoperiodism in the lower green plants. Internal conditions of the plant in relation to photoperiodism. Length of day as an ecological factor. References.

INTRODUCTION

Nearly all of the early work relating to the influence on plants of the daily duration of light was directed toward ascertaining the extent to which both the general growth or increase in mass and the development of the plant may be stimulated by lengthening the normal light period. The question as to whether, on the one hand, plants generally require a daily rest period for normal growth and development or, on the other hand, are capable of thriving under continuous illumination was given considerable prominence in these investigations. The two methods of approach consisted essentially in obtaining observations on plant growth within the Arctic circle, where continuous sunlight prevails during the summer months, and exposing plant cultures in lower latitudes to artificial light for a portion or all of the night as a supplement to natural daylight.

According to Smith (69) apparently the first mention in literature of the influence of length of day on plants is found in Carl von Linné's "Rön om växters plantering grundat på naturen" (41), published in 1739. However, Linné ascribes the rapid growth and early maturity attained by plants in polar regions to additional heat supplied by the continuous sunlight rather than the additional light as such. Schübeler, in 1879 (66), advanced the idea that the cereals and other species of plants when gradually transferred from lower to higher latitudes undergo definite change in growth characteristics. They were believed to acquire ultimately the capacity to shorten the vegetative period, increase the size of leaf, produce larger seeds, and increase their content of aromatic and coloring matters. However, the data on which these conclusions were based are meager and inadequate. Schübeler ascribed the observed effects to direct or indirect action of the additional sunlight. In 1880

and 1881 Siemens (67) reported results obtained in the culture of a number of species with the electric-arc lamp used to replace daylight and to supplement the latter so as to afford continuous illumination. Disclaiming any intention of generalizing, Siemens reached the conclusion that under suitable conditions electric light may effectively replace or supplement daylight and that plants apparently do not require a daily rest period. The continuous stimulus of light was found to be favorable for healthy development at a greatly accelerated rate through all stages of the annual life cycle of the plant from the early leaf to the ripened fruit. Peas grown under continuous light produced viable seed.

Kjellmann (35), during a sojourn on the north coast of Siberia in 1878 and 1879, as a member of the Vega Expedition headed by Nordenskiöld, conducted experiments with the Arctic species, *Catabrosa algida* and *Cochlearia fenestrata*, which were exposed to the continuous northern daylight and to a 12-hr. day. As compared with the shortened daylight period, the continuous illumination induced a more rapid rate of growth, and earlier and more profuse flowering. These results were taken to indicate that plants may continue the assimilation processes throughout the continuous daily light period, and as a result their development is materially hastened. The effects on flowering, however, were of a quantitative rather than a qualitative character and were not particularly striking. In the period 1891 to 1893 Bailey (8) conducted investigations with electric light from arc lamps used for a portion or all of the night as a supplement to daylight, primarily with a view to forcing vegetable crops. The additional light hastened the growth of lettuce and induced early flowering and formation of viable seeds in spinach. It was concluded that periods of darkness are not necessary to the growth and development of plants. Rane (56), working along similar lines with the incandescent carbon-filament lamp, obtained much the same results with lettuce and spinach and observed earlier blooming in certain flowering plants.

Bonnier (9) carried out experiments with a large number of species in 1894 and 1895 in which the arc lamp was utilized to produce a daily light period of 12 hr. as well as continuous illumination. Control plants were exposed to natural conditions of light during the winter months at Paris. Comparison of the experimental and control material was based almost entirely on anatomical observations. In general, the continuous illumination was found to cause thickening of the leaf and leaf stalk, reduction in size of leaf, poor development of mechanical tissue and to produce a superabundance of chlorophyll. The marked reduction in differentiation of tissues was considered strongly suggestive of the etiolated condition resulting from prolonged exposure to darkness. Using the incandescent gas light, Corbett (13) demonstrated that night illumination as a supplement to daylight stimulated markedly top growth

at the expense of root growth in sugar beets, and by its use he obtained earlier flowering in tomatoes. Stimulation of growth was observed in several other plants.

It will be observed that, with the exception of Bonnier, who dealt only with anatomical effects, all of the above mentioned investigators found that accelerated growth and more rapid development can be obtained in several species by increasing the daily light period even up to continuous illumination. In several instances the conclusion was reached that plants generally do not require a daily rest period. Although both conclusions may be regarded as sound so far as concerns the particular species in question and the conditions under which they were studied, as will later appear, it is now known that neither conclusion can be made to apply to all plants. In the work of Tournois (75) with *Cannabis sativa* and *Humulus japonicus*, published in 1911, there is to be found the first definite suggestion that attainment of the flowering stage may be hastened by a relatively short rather than a long daily light period. Tournois demonstrated that a precocious type of flowering which occurs in very early spring plantings of these species can be reproduced by allowing the plants to receive sunlight for only 6 hr. daily. Apparently this investigator did not extend his researches in this direction.

In a comprehensive attempt to ascertain the relation of external factors to reproductive processes in *Sempervivum* Klebs (36) made observations on the effects of varying the daily duration, the composition and the intensity of light. It is considered that attainment of the "ripe-to-flower" stage is conditioned primarily on an intensive carbon assimilation, accelerated transpiration, and a limited absorption of nutrient salts. Temperature is of special importance as it affects disassimilation. Light is essential for the laying down of flower primordia and it functions in the formation of the inflorescence somewhat as in the first phase of the reproductive process. It was found that 10 to 12 hr. of light per day were not sufficient to induce flowering and continuous illumination was more effective than 18 hr. of light. Though recognizing that there can be no simple relation between intensity and duration with respect to light requirements, Klebs finds a complementary relationship within limits and regards the quantity of the light energy as a decisive factor in the initiation and completion of the reproductive process.

DISCOVERY OF THE LENGTH-OF-DAY EFFECT

In a paper published in 1920 Garner and Allard (22) presented extensive data demonstrating the importance of relative length of day and night as a factor in the sharply contrasted growth and development of different species and varieties which are seen at different seasons of the year and in different latitudes. It was shown that not only does the seasonal and latitudinal change in length of day quite commonly affect

the growth and development of the individual species or variety, often-times to a remarkable degree, but the type and the grade of response to relatively long or short days may be very different in different species and varieties. In this paper particular attention is given to length of day in its relation to duration of the vegetative stage, that is, initiation of reproductive processes, including both the quantitative and qualitative phases of the subject.

As a background for their work these investigators previously had been concerned for some time with the peculiar seasonal behavior of certain varieties of tobacco and soy beans. A newly developed form of Maryland tobacco was found to maintain exceptional vegetative vigor through the open growing season without attaining the reproductive stage when propagated in the latitude of Washington, D. C. When grown in the greenhouse during the winter months this form of tobacco made only moderate growth and flowered and fruited abundantly. With certain varieties of soy beans, plantings at wide intervals through spring and early Summer tended to flower at approximately the same date in late summer, the vegetative period being progressively shortened with advance in date of planting. Experiments in varying the temperature and light intensity having failed to materially affect the length of the vegetative stage in the tobacco and soy beans, the simple expedient of shortening by a few hours the midsummer daily exposure to sunlight by use of a dark chamber was tried and very striking results were obtained. The shortened daylight period quickly initiated flowering in the tobacco plants and greatly hastened formation and ripening of seeds in cultures of the Peking variety of soy beans which had already flowered when the test was begun.

The tests were extended to a wide range of species and varieties and various day lengths were used. The technique employed was simple. During the open growing season large pot or box cultures of the test plants were excluded from daylight for portions of each day according to a fixed schedule and control cultures received the full daylight period. In regulating the daily light exposure a ventilated light-proof structure was employed and the cultures were transferred into and out of the structure by means of trucks mounted on steel tracks. Field plantings of early-, medium-, and late-maturing horticultural varieties of soy beans also were made at intervals through the late spring and summer period to observe the effects of changing day length. During the winter months bench or pot cultures in the greenhouse received each day supplementary artificial illumination of low intensity from late afternoon till midnight, supplied by tungsten-filament incandescent lamps. Control cultures were exposed to the natural daylight only. No effort was made to maintain fixed conditions, but as far as could be ascertained variation in the daily illumination constituted the only important difference in

environmental conditions as between the test plants and the controls in any particular series of experiments.

It was found that for most plants the relative length of day and night is a very important factor in growth and development, particularly in its action in initiating sexual reproduction. On the other hand, the duration of the vegetative stage in some species and varieties was not materially affected by length of day within the range occurring in the latitude of Washington, D. C. The more sensitive plants normally attain the flowering and fruiting stages only when the length of day falls within certain limits and consequently these stages of development ordinarily are reached only during certain seasons of the year. Of these plants some respond to a relatively long day while others respond to a short day. Different varieties or strains within the species often show marked contrast in their day-length requirements. With a day length which is unfavorable for initiation of reproductive processes vegetative growth may continue for a prolonged period, while a favorable light period may induce very early flowering and fruiting. In this way certain varieties or species become early- or late-maturing, depending on the length of day to which they are exposed.

Some of the relationships existing between annuals, biennials, and perennials, as such, depend in large measure on responses to the seasonal range in length of day. By regulation of the daily light period the annual cycle of the plant's activities can be greatly shortened or it can be lengthened almost indefinitely. Certain annuals were made to complete two cycles of alternate vegetative and reproductive activity in a single season. Likewise annuals showed some of the growth characteristics of perennials when exposed to a suitable day length. One of the outstanding results obtained is that reducing the number of hours of illumination by midday darkening, thus subjecting the plants to two periods of illumination daily, is not effective in inducing early blossoming in plants which readily respond to a single daily exposure of short duration. Within rather wide limits the total quantity of solar radiation received by the plant ordinarily is not a determining factor as regards attainment of the reproductive stage, that is, equivalent changes in the two factors, intensity and duration of light, do not necessarily produce similar effects.

In the species studied, including those in which flowering is induced by a short day, those flowering in response to a long day and those in which time of flowering was not affected by day length, the rate of growth as measured by height attained increased with increase in length of day. The daily light period is believed to be an important factor in the natural distribution of plants and in crop-plant adaptation.

The term *photoperiodism* was proposed to designate the phenomena embraced in the response of the organism to the relative length of day and night.

Three years later the same authors published a second paper (23) in which data are presented tending to confirm the results previously obtained and to show that the length-of-day factor affects various features of growth and development other than sexual reproduction. Observations were made on effects of day length in hastening or retarding flowering and fruiting in many additional species and varieties, and it was shown that under suitable conditions the formative action of the light period may be localized in the plant. Particular attention was given to the formation of bulbs, tubers, and thickened roots and the more or less antithetical process of stem elongation, as affected by the daily light period. Other influences of the light period studied include those on character and extent of branching, root growth, formation of pigment, pubescence, abscission and leaf fall, dormancy, senescence, and rejuvenescence. It is concluded that the duration of the daily illumination not only influences the quantity of photosynthetic material formed but also may determine the use which the plant can make of this material. It appears that for each species there is an optimal light period for maximum upward elongation of the stem or increase in height. In certain typical cases this optimal period is furnished by the long summer days of high latitudes, and progressive shortening of the day length may initiate a series of responses including flowering and fruiting, branching tuberization, and entrance upon dormancy.

Shortening the day length by a certain decrement below the optimum for stem elongation may induce intense reproductive activity and in annuals this is commonly accompanied by rapid senescence and death. Reduction in the light period to a point intermediate between the optimum for stem elongation and the optimum for flowering favors a combination of the two types of activity, as manifested in the ever-blooming condition. Reduction of the light period below the optimum for stem growth, and usually below the optimum for flowering, may induce intense tuberization. Here, again, with an intermediate light period sexual reproduction and formation of tubers may proceed simultaneously. Change in the light period from optimum to suboptimum for stem elongation may cause the apex to lose its dominance, thus promoting branching. Depending on the extent of the change in the light period, increased branching may occur at the upper, middle, or lower aerial portions of the axis; there may be various degrees of erectness of the branches; or there may be increased development of underground stems and a change downward in direction of their growth.

Further details of the results reported in these two papers and their interpretation are given in connection with the following outline of the development and the present status of principal phases of the day-length effect. Photoperiodism in its various manifestations and its relationships with other environmental influences has been the subject of exten-

sive research in the past decade and it will not be practicable to include in the present survey all of the work which has appeared in this field. In general, there has been remarkable agreement in the results obtained by various investigators with regard to the basal principles of the subject, though difference of opinion has developed as to the correct interpretation and the significance of some of the experimental data. General reviews of the subject of photoperiodism at different stages of its development have been presented by Maximov (44), Kellerman (34), Redington (60), and Schick (65). These authors have included fairly extensive bibliographies, as have also Lubimenko and Szeglova (43) and Tincker (71) in their research papers. Ramaley (55) has recently published a bibliography of day-length and artificial illumination as affecting seed plants.

LONG-DAY AND SHORT-DAY PLANTS

As pointed out by Garner and Allard, some plants are not particularly sensitive to differences in length of day. Such plants flower more or less readily in either a long or a short day, the effects of differences in the light period being of a quantitative rather than a qualitative character. There is a larger group of plants, however, in which length of day may produce definite formative action, particularly with respect to sexual reproduction. This group may be logically separated into two subdivisions, in one of which under suitable conditions flowering is readily induced by exposure to a relatively short day, while in the other flowering is favored by a relatively long day or even continuous illumination. The former are designated as "short-day plants" and the latter as "long-day plants." In setting up this classification, which now has come into rather general use, the authors recognize that for both the long-day and short-day types there is in each case a critical length of day for flowering. Short-day plants flower readily under day lengths below the critical, but with day lengths in excess of the critical there is extensive stem elongation without flowering. In long-day plants, on the other hand, there is elongation of the axis followed by flowering with day lengths in excess of the critical, but there is no flowering with day lengths below the critical, and most typical plants of this group tend to remain in the leaf rosette stage. In the less sensitive group, which now has come to be known as the indeterminate or neutral group, there is no definite critical day length for flowering.

The foregoing classification rests primarily on differences in response to length of day with respect to reproductive processes, although typically there is also definite contrast in the alternative types of vegetative activity in the long-day and short-day types. Separation into the two groups is not based on any particular day length as the dividing line (21*a*). In most cases short-day plants flower more or less readily through a wide

range in day length below the critical and the same is true of the long-day group for day lengths in excess of the critical. It appears that there are some plants, however, for which it is possible to have a day length too long as well as one too short to induce flowering. Most investigators have accepted this plan of classification, at least in principle, though in a few



FIG. 1.—Contrasted day-length responses of long-day and short-day types. Upper, *Steironema ciliatum* (L.) Raf., a long-day plant; lower, *Rumex* sp., a short-day plant. Left to right, the light exposures were: full summer day at Washington, D. C., of 14 to 15 hr.; darkened 10 A.M. to 2 P.M.; 12-hr. day; 10-hr. day; 8-hr. day; 5-hr. day. For the long-day type, *Steironema*, the critical light period for flowering under the conditions lies between 12 and 14 hr. and with periods below the critical the plant tends to remain in the leaf rosette stage; for the short-day type, *Rumex*, the critical period is about 11 hr. and with longer day lengths the plant develops indeterminate vegetative stems. Midday darkening produces no formative effect in either type of plant.

instances plants have been classified into long-day or short-day types on the basis of relative growth and production of dry matter, or contrast in development not involving reproduction, in response to long and short day. There has been some attendant confusion in the discussion and in the interpretation of results. Schick (65) has recently proposed

that for those plants in which tuber formation is of primary importance this response to the light period rather than flower formation be used as a basis for classification. This suggestion seems logical though possibly not entirely free from objection. Redington and Schiek in their reviews have listed the long-day, short-day, and neutral or indeterminate plants, as far as they have been reported in the literature.

FLOWERING AND FRUITING RESPONSES

Although the light period may affect sexual reproduction both qualitatively and quantitatively, up to the present most work has been directed toward the qualitative effect. While most short-day plants flower readily through a wide range in day lengths below the critical and most long-day plants flower under various day lengths in excess of the critical, available evidence indicates that there is a fairly definite optimum length of day for initiation as well as for completion of flowering and fruiting processes. Generally speaking, however, the intervals or gaps between the different light periods employed by investigators have been too wide to permit of establishing the optimum light period for any particular plant. Garner and Allard found for certain varieties of soy beans no significant difference in time required for flowering under a 12-hr. day and a 5-hr. day, but this does not preclude the possibility that an intermediate day length would somewhat further accelerate flowering. With these varieties a day length of 13 hr. or longer produces decided delay in flowering. For hemp, a short-day type, McPhee (48) obtained maximum acceleration of flowering with a 7-hr. period of light. McClelland (46) found that for *Tephrosia candida* a 12-hr. day is optimum for flowering while the process is inhibited by both a 10-hr. and a 13.2-hr. day. Allard (4) found an 18-hr. day to be optimum for *Sedum telephium*, although longer day lengths were not tried. According to Smith (69) continuous illumination produces maximum acceleration of development, including flowering and fruiting, in barley, oats, rye, and English sword pea. Further work is needed on this phase of the photoperiodic response with a more complete schedule of light periods, providing relatively narrow intervals between the periods and with better control of conditions.

Only very limited data are available as to the quantitative effect of day length on flowering and fruiting, at least as regards optimal light periods. In case of the soy beans mentioned above the absolute yield of seeds per plant was approximately 9 times as great with a 13-hr. day as with a 10-hr. day, but with the shorter light period the relative weight of the seed as compared with the weight of the stalk was more than twice that with the longer light period. A day length especially favorable for flowering also increased the weight of the individual seed. In cultures exposed to regulated day lengths of 4, 6, 8, 10, and 14 or 16 hr. Lubimenko and Szeglova (42) obtained maximum relative weight of fruits

with the 8- and 10-hr. light periods in *Momordica Charantia*, *Benincasa cerifera*, *Phaseolus vulgaris*, and *Soja hispida*. The same light periods also gave maximum absolute weight of fruits. Of these species all flowered with each light period employed except *Soja* which flowered only with day lengths of 6 to 10 hr. However, *Benincasa* produced few fruits with a 16-hr. day, the yield being exceeded even by that of a 4-hr. day. With *Sinapis nigra* all of the light periods shorter than 14 hr. proved to be insufficient for flowering and fruiting.

The conception of the ever-blooming or ever-bearing condition in relation to the day-length factor advanced by Garner and Allard seems to have been interpreted by some as being generally applicable to the group of neutral or indeterminate plants. Although this group may logically be considered as the chief source of ever-bloomers, the conception in question has to do essentially with a rather delicate balance between vegetative activity and reproduction which may be maintained by suitable light periods in typical long-day and short-day plants as well as in those of the neutral group. In buckwheat, which flowers successfully with all day lengths from 5 hr. upward, a short day induces rapid, intensive reproductive activity and only limited growth, so that the life cycle is soon terminated. In this case the plant is an ephemeral. With a long day, on the other hand, slower, less intensive reproduction is accompanied by extensive new growth, making possible a long-continued process of flowering and fruiting, so that the life cycle is greatly extended. In the latter case there is obviously a tendency toward the ever-blooming state. In the same way, the short-day type, *Viola papilionacea*, which produces its blue spring type of blossom in response to a short day, will continue to produce this type of blossom for a prolonged period when exposed to a favorable intermediate light period, but ceases to do so with longer daily illumination. It has been suggested that in nature the narrower seasonal range in the daylight period which occurs in low latitudes is especially favorable to the phenomenon of ever-blooming.

Schaffner (62, 63) has made extensive study of the effect of day length on sex reversal and related structural abnormalities in *Cannabis sativa* L., *Zea Mays*, and other species. Beginning July 1 and extending over a period of 10 months, semimonthly plantings of hemp were made in the greenhouse to ascertain the effects of the seasonal change in the daylight period on sex reversal in staminate plants. A very perfect fluctuating curve was obtained ranging from zero reversal in the late spring and early summer plantings to 100 per cent reversal for the November plantings. On November 1 plantings of certain forms of *Zea Mays*, 100 per cent of the plants will show under suitable conditions some degree of female expression in the tassel while spring and early summer plantings normally show only pure staminate tassels. When the female state is established in the main stem, the internodes become decidedly

flexuous and may form loops. Under the length-of-day gradient from August to November a large percentage of completely neutral, vestigial tassels can be developed in a population. With the decreasing day length of autumn femaleness is expressed only at the base of the tassel, the middle region is staminate, and the tip is always neuter. With the increasing day length of late winter and early spring femaleness also may be expressed in the tip and branches. Tournois (75) described numerous abnormalities in reproductive structures of hemp associated with precocious flowering in response to the short days of early spring.

In a study of the influence of light on the unfolding of the flower bud in *Hedera Helix*, which behaves as a short-day plant, Sigmond (68) found that the processes involved are rhythmic in character and are facilitated by the alternation of day and night, so that night illumination has a retarding effect. Light has no direct stimulating action on the opening of the flower.

GROWTH RELATIONS

The fact that entrance upon reproductive activity usually checks or abruptly terminates growth in the plant makes it somewhat difficult to obtain a clear picture of growth relations as affected, on the one hand, by light periods which tend to initiate reproduction and, on the other hand, by periods which favor only vegetative activity. In general, growth characteristics of the short-day type of plant with light periods below the critical rather closely resemble those of the long-day type of plant with light periods above the critical. In both cases the rate of growth, the height attained, and the production of dry matter as a rule tend to increase with increase in duration of light, but there are certain plants which are injured by a very long daily light period and there are still others which grow best even with a moderately short light period. Similar growth characteristics also will apply to the indeterminate group of plants with all light periods, since in this case flowering is always involved. The situation is different where light periods tending to suppress reproduction come into play. With the short-day plant there is, as a rule, comparatively little change in the general type of growth, except as to absence of flowering and fruiting, but in the long-day type important morphological changes usually appear and total production of dry matter affords about the only simple basis for comparison. Since vegetative activity usually will continue at a rapid rate for a prolonged period in short-day plants exposed to day lengths above the critical, the final height and the plant mass may greatly exceed those of plants exposed to shorter day lengths which induce early flowering. This may hold true, but to a much lesser extent, for the long-day plants exposed to light periods too short to induce flowering.

Garner and Allard obtained maximum height in several short-day plants with a long daylight period, but in *Holcus halapensis* L., another short-day type, a 10-hr. day produced the tallest plants. In several types of *Dactylis glomerata*, a long-day species, Tincker (71) obtained a much greater height in the full summer day than with a 12-hr. day; and with a 9-hr. day the plants remained in the leaf-rosette stage. Various other long-day species showed more or less similar results. Using daily light periods of 4, 6, 8, 10, and 14 or 16 hr. Lubimenko and Szeglova (42) obtained maximum production of dry matter in *Benincasa cerifera* with an 8-hr. day and in *Phaseolus vulgaris* with a 10-hr. day. In *Momordica Charantia*, *Gossypium herbaceum*, *Soja hispida*, *Hordeum vulgare*, and *Sinapis nigra* the 14- or 16-hr. period was more effective, and with a 10-hr. day the dry weight of *Papaver nudicaule* was only 8 per cent of that produced by the 16-hr. day. The relative production of dry matter per hour of daily illumination was highest with the 16-hr. light period in *Soja* and *Papaver*, with the 8-hr. light period in *Momordica*, *Gossypium*, *Phaseolus*, *Hordeum*, and *Sinapis*, and with the 6-hr. period in *Benincasa*. Adams (1) obtained maximum height and largest production of dry matter in flax, wheat, sunflower, white mustard, and soy beans with the full day of summer.

As regards the above experimental data Smith (69) emphasizes the fact that for a given plant the relative effect of different light periods on the rate and amount of growth varies according to the stage of development at which the observation is made. Whether growth be measured as accumulation of dry matter, plant height, leaf size, or rate of increase in dry matter per day, per hour of illumination, or per unit of light, there is found a maximum displacement, the maximum values for young individuals of such species as oats, barley, rye, sugar pea, and tomato being obtained with continuous light but undergoing displacement toward the shorter light periods with increasing age of the plants. Apparently the factor, *i.e.*, length of day, has no fixed optimum for growth reactions. Observed differences in growth reactions to day length between different species cannot be considered as conclusive unless comparison has been made on a basis of equal periods of development.

It has been shown that many species may be maintained in a healthy state of vegetative activity over long periods of time by subjecting them to light periods which are unfavorable for reproductive activity. With day lengths above the critical, typical short-day plants may attain giant proportions. Similarly long-day plants exposed to day lengths shorter than the critical for flowering may remain vegetatively active for long periods, though usually total growth is relatively restricted. Garner and Allard (26) were able to maintain certain species of *Sedum* in the vegetative stage without flowering for as long as 9 years by exposing them to daily light periods of 12 hr. or less. At the end of the test these

plants quickly flowered when exposed to a long day. Similarly Tincker (72) maintained *Trifolium pratense* in a healthy, nonflowering condition for 4 years by employing a light period of 10 hr. and *Avena sativa* exposed to a short day was caused to function as a biennial. Kondo (38) obtained vigorous growth but no development of panicles in rice plants exposed to continuous light for a period of 3 years, although these plants developed normally and formed seeds when subsequently exposed to favorable day lengths.

FORMATION OF TUBERS, BULBS, AND THICKENED ROOTS

It was shown by Garner and Allard (23) that tuberization in its various forms of expression is a prominent feature of photoperiodism. Cultures of the McCormick, a late variety of potato, were exposed in one case to the full daylight period of summer plus weak artificial illumination from sunset till midnight, and in a second case to the full daylight alone. The average temperature was relatively high. In a second test the cultures were exposed to the full day and to day lengths of 5, 10, and 13 hr. With the artificially lengthened day no tubers were formed and an underground bud, which otherwise might have given rise to a tuber, failed to go into a resting state, but instead immediately germinated and developed into a new plant. In each test the full day yielded a fair crop of tubers, but the maximum absolute weight of tubers was obtained with a 13-hr. day while by far the highest yield in percentage of total weight of plant was produced by the 10-hr. day. The highest total weight of the plants and the greatest plant height were obtained with the longest day.

With a 10-hr. day *Apios tuberosa* produced relatively few but large new tubers, while the mother tubers were much enlarged and formed numerous prominent resting buds. With the full summer day many new tubers of small size were developed and there was little enlargement of the mother tubers which formed only a few small resting buds. With *Dioscorea divaricata* L. a short day checked growth of the vine and induced early tuberization of aerial axillary buds without materially affecting relative production of underground tubers. In tests with the yam, *D. alata* L., a 10-hr. day suppressed formation of aerial tubers but greatly increased both the absolute and the relative yields of underground tubers. With *Helianthus tuberosus* L. the short day produced small, short-lived plants and while flower buds appeared, they were never able to open. There was intensive tuberization, both the absolute and the relative yields of tubers exceeding those produced by the controls, and the numerous elongated underground stems produced by the latter were lacking. The short day produced marked thickening of the root in *Phaseolus multiflorus* Willd.

The photoperiodic response of onion stands out in sharp contrast with the preceding data on tuber formation. With a 10-hr. day the

Silverskin onion remained in the vegetative stage without indication of flowering or of forming bulbs over a period of more than 12 months. With the full summer day the plants flowered and formed large bulbs which soon passed into the resting stage but resumed vegetative activity when the day length had shortened sufficiently in autumn.

The relation of day length to tuber formation also has been studied by several other investigators. McClelland (47), under Puerto Rican conditions, obtained a sevenfold increase in production of tubers in the Lookout Mountain variety of potato with a 10-hr. day as compared with a 15-hr. day, and a smaller increase in the Irish Cobbler while the yield was not affected by the light period in the Red Bliss. In all cases, however, the ratio of tubers to tops was vastly greater with the short day than the long day. Growth of tops was much greater in the long day. The light requirements for bulb formation in different varieties of onions was found to be highly specific, but in all varieties a short day prevented formation of bulbs and favored leaf growth. Zimmerman and Hitchcock (78) observed that in six varieties of *Dahlia* the length of day determined the type of root system formed, storage roots being correlated with a short day and a fibrous root system with a long day. According to Doroshenko and associates (18) the normal summer day length in the region of Leningrad completely suppressed tuber formation in several forms of *Ullucus* and *Oxalis* and in South American species of *Solanum*. While all native cultivated varieties of potato were capable of forming tubers under the long summer day, both the yield and the number of tubers formed were increased with a short day. The optimum light period for tuber production was found to be 9 to 12 hr. The process of tuber formation shows a specific dependence on length of day. Schick (64) at latitude 52.5° north has reported similar results with potatoes.

In contrast with the foregoing results Arthur and others (5) find that in the Irish Cobbler variety of potato formation of tubers is favored by long days when associated with low temperature and high intensity of light. Undoubtedly low temperature often favors tuber development in the potato, but with respect to the day-length factor it must be concluded that the relation to tuber formation is largely a matter of the variety and species. This seems reasonably clear from the previously mentioned results of other investigators at various latitudes.

It is apparent that the daily light period is an important factor in the formation of tubers, bulbs, and thickened roots. In this type of response, as in the case of sexual reproduction, plants vary in their sensitivity to the day-length factor. Moreover, among the more sensitive plants the optimum day length for this type of development varies with the species and with the variety. Practically without exception, however, under normal growing conditions investigators have obtained the maximum relative production of tubers (and thickened roots) with a short

day. This has been shown to hold true for a wide variety of plants and in regions representing a very wide range in latitude. Adequate vegetative growth, of course, is a prerequisite for extensive tuber development, and inasmuch as general growth usually is much restricted by a decidedly short light period, it commonly occurs that maximum absolute yield of tubers is obtained with only a moderately short or intermediate length of day or more rarely with a long day. On the other hand, bulb formation, at least in the case of the onion, is induced by a long day, though there are distinct varietal differences as to the most favorable daylight period for this response (47).

SENESCENCE, DORMANCY, AND RELATED PHENOMENA

With suitable light periods both the long-day and short-day types of plants may maintain vegetative activity for very long periods of time without appearance, or definite evidence, of senility in the organism as a whole. In annuals, exposure to optimal light periods for flowering and fruiting tends to induce rapid senescence and death. Similarly certain light periods may cause perennials to enter into a state of dormancy. Periods of light which are only moderately suboptimum may permit limited reproductive activity, and in this case rapid senescence may be limited to certain plant organs or parts, while the organism as a whole is able to continue activity. Again, it has been shown (22) that typical annuals as well as perennials in which intensive reproduction has been initiated by a favorable day length may be rejuvenated by transfer to a length of day promoting vegetative activity. Such typical annuals as soy beans and the perennial *Aster linariifolius* were made to complete two cycles of alternate vegetative and reproductive activity within a period of 4 months. Schaffner (63) also was able to effect rejuvenation in *Cannabis sativa* by applying continuous illumination to plants which previously had been exposed to the natural short day of winter and had flowered. If the plants come into flower in spring when the day is rapidly lengthening, they may rejuvenate naturally, and after rejuvenation there is a succession of leaf forms corresponding to those which develop in juvenile plants from seed.

In tests by Garner and Allard (23) cultures of *Liriodendron tulipifera* were transferred to the greenhouse in September and one series received weak supplementary illumination from sunset till midnight. With natural light alone the plants soon lost their leaves by abscission and remained dormant through the winter. Under the long-day conditions there was prompt renewal of active growth with abundant development of new leaves. There was no definite period of leaf fall and as individual leaves died the petioles remained firmly attached to the stem. In *Rhus glabra* L. there was no new top growth with the long day but there was no leaf fall, the leaves retained a dark green color, and eventually

new shoots emerged from the soil as offsets. In similar tests Oden (52), by lengthening the autumn day to 17 hr., caused the usual rapid autumn leaf fall in *Acer campestre*, *Lonicera Periclymenum* and *Viburnum Opulus* to be replaced by continuous dropping of the leaves. After normal leaf fall the added illumination caused the new buds to unfold and new leaves were developed.

In first-year cultures Moehkov (49) found that *Robinia Pseudo-Acacia* L., a representative of lower latitudes, grew slowly from the outset in a 10-hr. day, but in the full day rapid growth continued till stopped by cold, so that the wood did not ripen. On the other hand, *Salix lanata* L., a representative of high latitudes, grew more rapidly in the 10-hr. day but soon terminated its activities, while in the full day growth continued for a longer period and ultimately was much greater in amount. Nevertheless, the long-day cultures became inactive long before winter set in.

Dexter (16) has recently studied effects of day length on hardening in alfalfa, wheat, cabbage, and tomato at different temperatures. At 0°C. wheat and alfalfa hardened more fully in a long day than in a short day and there was no decided indication of elongation. Winter wheat plants previously exposed to a short day at 60°F. hardened more fully in the cold room than plants which had been in a long day when placed in either a long- or a short-day hardening treatment. At higher temperature a short light period interfered seriously with the hardening process only in winter wheat, but a long light period caused elongation of foliar parts in each of the species studied.

MORPHOLOGICAL AND ANATOMICAL EFFECTS

Following the early work on the subject (23), the fact that the morphology of plants may be variously modified by the day-length factor has been demonstrated by a number of investigators. Doroshenko (17) found that associated with retarded reproductive activity in wheat and barley, which are long-day plants, when these plants are exposed to a short day, there is a marked increase in leaf development, amounting in some instances to 10 times that under long-day conditions. In flax, another long-day type, increase in basal branching was observed under short-day conditions and there was decreased leaf development. Lubimenko and Szeglova (42) subjected a number of species to various regulated day lengths and on the basis of results obtained the conclusion is reached that for each combination of day and night there exists a special form of the plant from the standpoint of relative development of the different organs. In *Hordeum vulgare* fruiting occurred only in the full day, maximum production in percentage of total dry weight was obtained in a very short day for the leaf, in the full day for the stem, and in intermediate day lengths for the root. In *Benincasa cerifera*,

Momordica Charantia, *Soja hispida*, and *Phaseolus vulgaris* maximum fruiting was obtained with the intermediate light period. Maximum relative production of leaf occurred in the long day with *Soja*, in the very short day with *Phaseolus*, in both the long and very short days with *Momordica*, and was not affected by day length in *Benincasa*. Relative weight of stem was not much affected by the light period in *Momordica* and *Phaseolus* and was greatest with both the long and the very short day lengths in *Benincasa* and *Soja*. Relative weight of root in *Benincasa*, *Momordica*, and *Phaseolus* was greatest with the long day, in *Hordeum* and *Sinapis* in the intermediate day lengths, and with both the long and very short days in *Soja*.

In a study of the relation between top and root size in herbaceous plants Crist and Stout (14) obtained consistently a decided increase in top-root ratio in lettuce and radish with decrease in the daily light period. In a comprehensive investigation of relative development of root and tops in several species representing the long-day, short-day, and indeterminate types Weaver and Himmel (77) obtained in all cases a close correlation between the transpiring surface and the absorbing system. With a 7-hr. day the growth of both tops and roots was greatly retarded and approximately to the same degree when compared with results in a 15-hr. day. In *Dahlia*, however, there was a greater development of short, thick, tuberous roots in the short day. The available data as a whole indicate that, although there are exceptions, the general tendency with different light periods is toward development of a fibrous root system more or less proportional to the growth of tops.

In anatomical studies of the stem of tomato and pepper exposed to regulated day lengths Deats (15) found that the amounts of both bast and xylem and the thickness of their cell walls varied directly with the length of day as did also the size of the epidermal cells and amount of cork development. Stems exposed to a short day contained relatively more pith. The height and diameter of the stems and the size and thickness of the leaves were directly proportional to the length of day. To study the effect of the light period on fiber production in plants Redington and Priestley (61) grew *Aster*, *Chrysanthemum*, *Pelargonium*, and *Polygonum* with artificial light, using day lengths of 8 and 16 hr. and continuous illumination. Sclerenchyma was more abundantly developed under the 16-hr. period than with continuous light. With an 8-hr. period the thinness of the walls of the fibers was very striking. In cultures of flax, wheat, and barley exposed to the full day and shortened days of 12 and 9 hr. Doroshenko (17) observed that the moderately shortened day causes reduction in size of the cells and of stomata in the leaves, and an increase in number of stomata and venation per unit of surface area; but with a very short day these effects are reversed. However, the various forms are highly individualistic as to most favorable day

lengths for these responses. In flax the thickness of the stem and the development of xylem and phloem decrease, while the diameter of the pith increases with decrease in the daily light period.

THE PHOTOPERIODIC AFTEREFFECT

(Photoperiodic Induction)

Observations were made by Garner and Allard on the minimum number of days in an initial treatment with a light period favorable to flowering which is required to obtain definite response when the plant is subsequently transferred to a day length distinctly unfavorable to flowering. With typical short-day plants it was found that initial exposure to a short day for at least 10 successive days was necessary to obtain flowering when the plants were subsequently exposed to a long day. A longer pretreatment with the short day was required to obtain abundant flowering and the minimum pretreatment period for successful fruiting was about 21 days. In this connection, in view of the fact that in nature plants usually are subjected to a changing rather than a fixed length of day, Russian investigators have recently emphasized the importance of this phase of photoperiodism. The carry-over effect of a given light period after the plant comes under the influence of another light period has been designated as "photoperiodic induction" and as "the photoperiodic aftereffect."

Rasumov (57) studied the aftereffects on growth and development in representative short-day and long-day types of an initial exposure to a long- or a short-day length for various periods, and the relation of these effects to those dependent on time of seeding. The day length experienced by the plant at the beginning of development is found to be of great significance in its later development, particularly as to the transformation from the vegetative to the reproductive stage. Pretreatment with the shortened daylight period for some days markedly hastens flowering in short-day plants and delays it in long-day plants. Similar exposure to a long day produces reverse effects in the two types. The degree of acceleration or retardation in the onset of flowering lies between the extreme effects of continued long-day or short-day exposures so that the alternating treatment may be employed to regulate the time of flowering. In the short-day type of plant the strongest aftereffect is produced by a short day and in the long-day type the reverse is true.

In similar experiments with species of the short-day and long-day types Lubimenko and Szeglova (43) likewise found that the initial exposure to a long or a short day serves to displace the time of flowering, an effect which is called photoperiodic induction. The retarding or accelerating effects are manifested in both the vegetative and the reproductive phases of development. Pretreatment with total darkness accelerates subsequent development of the short-day type and retards

that of the long-day type when the plants are transferred to a long day. The pretreatment with long or short days affects not only the rate of development of the plant as a whole but influences differently the various organs. The persisting effects of the initial day length treatment may be explained by assuming that a rather stable structure of the protoplasm is created which determines from the outset the rate of development of the whole plant and its various organs.

Rasumov (58) has shown that the photoperiodic aftereffect is of importance in the process of tuber formation. Though different species vary widely in their sensitivity to day length with respect to tuber formation, generally speaking a short day affords optimum conditions for formation of tubers and produces the maximum yield in relation to general development of the plant. An initial exposure to a long day so as to favor extensive top development, followed by exposure to a short day to induce rapid tuberization usually produces maximum absolute yield of tubers. The reverse treatment, due to the aftereffect of the initial short-day exposure, may produce a small crop of tubers, but frequently the subsequent long-day effect causes the tubers to revert to stolons and give rise to new shoots. Kondo (38) found that a short-day exposure throughout the seed-bed stage produced two crops of panicles in the rice plant, but shorter treatments produced no persisting effects.

SUPPLEMENTARY ARTIFICIAL ILLUMINATION AND CONTINUOUS LIGHT

As was pointed out in the introductory paragraphs, early workers found that with certain species night illumination with artificial light from various sources could be used successfully as a supplement to daylight to increase the rate of growth and development. Some of these investigators arrived at the general conclusion that plants do not require a daily rest period. In most cases not much attention was given to the intensity of the artificial illumination used. Subsequent research has shown that while the rate of development can be increased by use of continuous light in many plants of the long-day or indeterminate types, some are more or less severely injured, or even killed, by uninterrupted illumination. The amount of injury undoubtedly is influenced by the intensity of the light and by other factors. It was observed by Garner and Allard that in many cases supplementary illumination of an intensity of less than 5 foot-candles when used to prolong the daily light period may function much the same as the natural long day so far as concerns formative effects. In particular the supplementary light may promote flowering in long-day plants and retard it in short-day plants.

Similar observations have been made by several other investigators. Adams (2) observed that with a daylight period of more than 12 hr. weak supplementary illumination for 5 to 6 hr. prevented flowering in soy beans, did not hasten flowering in tomato or buckwheat, retarded

growth in hemp, but aided growth and development of spring wheat. Tincker found that by use of supplementary illumination of 2 to 5 foot-candles intensity to increase the light period from 12 to 17 hr., much the same effects were obtained as with a natural daylight period of approximately the same duration. Oden (52) employed supplementary electric illumination in forcing various plants in the greenhouse and concludes that as a rule the gas-filled incandescent lamp supplying a preponderance of light of the longer wave-lengths is a desirable source, although for certain species best results were obtained with light relatively rich in the shorter wave-lengths.

As regards continuous illumination as such, generally speaking the effects on reproductive activity in long-day and short-day plants is similar to that of the long day, that is, flowering and fruiting are accelerated in the former and retarded in the latter. In many plants, though by no means in all, continuous light produces maximum growth, at least with the sources and intensities of light that usually have been employed. Apparently in no case has uniform illumination of the intensity and composition of strong sunlight been used in such tests. Results obtained by several investigators with a combination of daylight and artificial light already have been considered. With electric light of moderately high intensities as the only source of illumination Harvey (31) was able to grow a number of species from seed to seed, though no controls were provided for direct comparison with responses to regulated day lengths. Ramaley (54) grew several caryophyllaceous species from seed to seed in continuous light derived from daylight and artificial night illumination and obtained earlier flowering and taller plants with the uninterrupted illumination. In the far North Smith (69), utilizing the natural continuous daylight of summer, daylight supplemented with artificial light, and the latter alone, found that with several species the maximum mean rate of development was obtained with the continuous illumination, though, in some cases, the rate of development per hour of illumination was greatest with short day lengths.

On the other hand, continuous light has been shown by several investigators to produce definite injury to certain plants, and growth may be restricted even though no pathological symptoms are evident. Redington (60) finds that for a number of species studied a daily period of darkness is not essential, although, in most cases, the largest and best plants were obtained with a 16-hr. day. Arthur and others (5) grew numerous species in different day lengths and in continuous light supplied as artificial illumination alone or daylight supplemented with the artificial illumination. The carbon dioxide supply also was varied and the conditions were accurately controlled. In general the continuous illumination was more effective when the carbon dioxide supply was increased. Tomato was unable to tolerate continuous illumination,

though it was somewhat less injured when sunlight entered into the illumination. It is thought that the injury which involves defoliation is produced by a breaking down in the process of photosynthesis rather than excess accumulation of photosynthetic products. *Pelargonium*, *Coleus*, and *Nicotiana Tabacum* also showed definite injury in the continuous light. Furthermore, some species which showed no definite injury were unable to benefit in growth from the continuous light as compared with an 18- or 19-hr. day-length.

Reference was made in the introductory paragraphs to the work of Bonnier (9) who obtained important modifications in leaf and stem structure in plants exposed to continuous artificial light. However, in a comparison of the anatomical effects of continuous light and various day-lengths on several species grown under controlled conditions Pfeiffer (53) was unable to confirm Bonnier's results. Several other investigators before and after Pfeiffer's work have reported a similar experience, so that apparently the effects observed by Bonnier were due, at least in part, to other factors.

INTERRELATIONSHIP OF OTHER ENVIRONMENTAL FACTORS

The manner and extent to which normal response to the day-length factor may be influenced by other factors of the environmental complex recently have been the subject of considerable study. As perhaps would be expected, it has been found that the relations are complex and under certain conditions the day-length effect may be variously modified or interfered with through the intervention of other supporting or opposing factors. Temperature perhaps is the most important factor involved. Suboptimal temperature, of course, will tend to slow down the rate of growth. Temperature also may have important effects on the rate and the character of development. Again, the natural seasonal change in length of day commonly is followed by a corresponding change in mean temperature.

In a study of *Xanthium pennsylvanicum*, a short-day type, exposed to different combinations of temperature and day length Gilbert (30) found temperature to be a determining factor in influencing the time of formation of flower primordia, but this effect was closely associated with a response to length of day. The interrelation of day length and temperature was found to be as follows: A high temperature, short-day exposure gave quick flowering; high temperature and long day resulted in definite delay in flowering; low temperature and short day decidedly prolonged vegetative activity; low temperature and long day also prolonged the vegetative period. In investigating the physiological factors which may determine the duration of the vegetative period in plants Maximov (44) finds that in addition to winter annuals some of the late-maturing forms of summer types may be much hastened in completion of the life cycle

by the aftereffects of germination in the cold. However, on the basis of experimental data obtained, this investigator concludes that length of day is more effective and more general in its action as a formative factor, only relatively few plants being indifferent to the light period.

In a study of interrelationship of temperature and length of day as affecting winter and spring types of cereals Enomoto (20) found that in all varieties of wheat and barley tested heading was accelerated by high temperature, wheat being somewhat more sensitive than barley. As a whole the wheat varieties were much less sensitive to day length than the barley varieties. The most typical winter varieties are least sensitive to both high temperature and long day, while the most typical spring varieties are highly sensitive either to high temperature or to day length or they are moderately sensitive to both. Among varieties showing a similar grade of response to one of these factors the grade of the spring-growing habit is correlated with the grade of response to the other factor. Further, the grade of the spring-growing habit may be roughly proportional to the sum of the grades of responses to high temperature and to long day.

The comparative responses of early-, medium- and late-maturing varieties of soy beans to temperature and day length were studied under partially controlled conditions by Garner and Allard (25). In greenhouse plantings made at short intervals through the year under favorable temperature conditions all three varieties reached the flowering stage in about 25 days when grown during the period of 6 months in which the day length was relatively short and, therefore, behaved as early-maturing sorts. With the increasing day length of spring, however, first the late and subsequently the medium forms suddenly changed from the spring-flowering to the fall- or late-summer-flowering type, that is, flowering was deferred till the return of short days. In the early sort the duration of the vegetative stage did not undergo any marked change. The increasing length of day apparently exercised a definite selective action on the different varieties. With a fixed day length of 10 hr., outdoor plantings made at intervals through the growing season showed close correlation of the length of the preflowering stage with the mean temperature, but relatively low temperature delayed flowering to about the same extent in the latest and earliest varieties. Apparently change in temperature exercised no selective action on the different varieties. These data and the results of extensive field plantings indicate that in this particular species variations in duration of the vegetative stage from year to year in both early and late varieties, when planted on any particular date, are due chiefly to differences in temperature, while length of day is the principal external factor responsible for the fact that in higher latitudes one variety is always relatively early and another late in flowering and fruiting.

The interrelationship of intensity and duration of illumination also is of interest, more especially in that the product of the two constitutes the amount of light received by the plant. It will be recalled that Klebs regarded the quantity of the light energy as of decisive importance. It is now known, however, that this will hold true only for certain conditions and usually within rather narrow limits. It has been made clear that prolonging the daily light period by means of exceedingly weak illumination may change the rate and character of growth quite out of proportion to the quantity of light energy added. Shading tests (23) with soy beans have shown that reducing the intensity of sunlight to less than a third of the normal does not materially affect the time of flowering. It is to be recalled, also, that midday darkening for several hours and thus excluding more than 50 per cent of the total light energy usually produces no important formative effects, whereas cutting off less than 5 per cent of the light energy by early-morning or late-afternoon darkening may cause definite formative action.

A comparative study of the effects of intensity and duration of sunlight on vegetative development of *Raphanus sativus* L. was made by Johansson (32) in which parallel cultures in the greenhouse were subjected to day lengths of 6, 8, 10, 12 hr., and the full day, with intensities of 23, 39, and 70 per cent of full sunlight. Total growth increased with increase in both the duration and the intensity of illumination though not in the same degree from the standpoint of energy relations. The root and the aerial organs responded differently to the two factors. The former is more sensitive than the latter to increase in the light period. With the highest intensity of light, maximum root weight was obtained in the full day but with lower intensities in the 12-hr. day. Root growth increased with increase in intensity of light with all day lengths, but for the leaf this relation held only with the 6- and 8-hr. light periods. The ratio of root development to total weight increased in all cases with increased light intensity but was not further increased by lengthening the day beyond 10 or 12 hr.

Smith (69) concludes from an analysis of his results that, while both the daily duration and the intensity of light influence the rate of development as well as the amount of growth, the light period has the greatest effect on rate of development, and light intensity chiefly affects the total production of dry matter. This conclusion, within limits, appears to be well supported by the data of other workers which already have been discussed.

Save for the observations of Oden, to which brief reference was made in the discussion of supplementary artificial illumination, it appears that as yet no detailed study of the interrelationship of spectral composition of light and length of day has been made. Comparatively little has been done, also, as to interrelationship of humidity or water supply

and the day-length factor. With soy beans Garner and Allard (22) found under the conditions of the experiment that differences in water supply of the soil had no effect on time of flowering, though a condition of comparative drought slightly hastened ripening of the seed. Gilbert (29) found that photoperiodic response was delayed in soy beans by a combination of relatively low temperature and high humidity, was delayed in *Cosmos* by the reverse combination of higher temperature and lower humidity, and was not affected by the ranges covered in *salvia*. Interrelationships of day length and the supply of essential nutrients will be considered in the discussion of internal conditions of the plant in relation to the light period.

EFFECTS OF ABNORMAL LIGHT PERIODS

Following up the fact that midday darkening, which in effect divides the daily illumination into two short light periods, fails to induce the usual responses of short-day and long-day plants to a short day, Garner and Allard (27) have studied the effects of abnormally long and short alternations of light and darkness. Darkening in the middle of the day, even for as long as 4 or 5 hr., does not hasten reproductive activity in the short-day type nor does it ordinarily delay reproductive processes in the long-day type. In these respects the effects are negative, the plants behaving as when exposed to the full day. Growth and general nutrition of the plant, however, may be adversely affected. When the plants were completely darkened on alternate days during the summer months, thus introducing a 48-hr. cycle of about 15 hr. of light and 33 hr. of darkness, the general effect was that of a short day, though this effect was materially weakened. Exposing plants alternately to the full summer day and a 10-hr. day length produced an effect intermediate between those of a short day and a long day with respect to initiation of flowering.

Plants of the long-day and short-day types were grown with short alternations of equal light and darkness ranging from 6 hr. to as short as 5 sec., using high-intensity artificial illumination. In all cases the effects on flowering were the same as those obtained with midday darkening, that is, all long-day plants flowered readily while short-day plants remained in the vegetative stage. The results are essentially those obtained with a long-day or continuous illumination. On the other hand, the differential effects of the various alternations on nutrition and growth of the plants were striking. As the equal periods of light and darkness were progressively shortened, there was increasing evidence of malnutrition and retardation in growth which in most cases reached a climax with the 1-min. intervals. With further shortening of the alternations there was definite improvement in the condition of the plants and with the intervals of 5 sec. the general nutrition and growth of the plants appeared to be normal. The long-day and short-day plants were

affected in much the same way. The injurious effects of the intermediate alternations of light and darkness included destruction of chlorophyll, localized dying of the leaf tissue, reduced leaf development, etiolation, and decrease in stem growth and in production of dry matter. When the duration of the light periods was reduced to one-half that of the periods of darkness, these injurious effects were accentuated and when the light intervals were correspondingly increased the condition of the plants was improved.

THE PHOTOPERIODIC RESPONSE AND HEREDITY

In 1919, before photoperiodic response had been recognized as a phenomenon of wide occurrence, Allard (3) made a study of the inheritance of the indeterminate or nonflowering type of growth exhibited by the Maryland Mammoth variety of tobacco (*Nicotiana Tabacum*) when exposed to a long day. It was found that in crosses with ordinary varieties, which readily flower in either long- or short-day lengths, the nonflowering character is recessive and F_1 plants readily flower in a long day. In the F_2 generation the nonflowering or mammoth plants occur in proportions approaching the simple Mendelian ratio of 25 per cent. Bremer (11) has reported observations on inheritance of day-length response in lettuce, the winter or spring and the summer sorts of which respond differently to length of day. The former develop no heads in the long days of summer but, on the contrary, at once produce flowering stems. The summer sorts are relatively indifferent to day length, forming heads in both long and short days. Bremer showed that this contrast in response rests on a simple Mendelian character. The allelomorph "formation of flowering stem is linked with day length" is dominant over the allelomorph "formation of flowering stem is not linked with day length." Further work will be required to determine to what extent such simple inheritance relations apply to other species and to other features of photoperiodism.

PHOTOPERIODISM IN THE LOWER GREEN PLANTS

Research has shown that some of the lower green plants are capable of responding to differences in the light period to a degree comparable with the effects on the higher plants. Karling (33) has reported results obtained with the aquatic, *Chara fragilis* Desvaux exposed to the winter daylight alone and supplemented with electric light at night. Under the conditions of the experiments length of day appears to be a primary factor in inducing the formation of antheridia and oögonia, the supplementary illumination of very low intensity effecting rapid response in midwinter, while in nature fruiting occurs only in summer and early fall. Under the conditions temperature, within the minimum and maximum limits for vegetative growth, apparently is a secondary factor

in determining the production and functional activity of antheridia and oogonia in this species.

Cultures of the liverwort *Marchantia polymorpha* L. were exposed to various day lengths in experiments conducted by Wann (76). It was found that this species responds to length of day in a similar manner to that characteristic of long-day flowering plants. When subjected to an artificially lengthened daily light period in winter, mature antheridiphores are produced in 3 to 4 weeks, mature archegoniophores in 6 to 8 weeks and mature sporophytes in 10 to 12 weeks. A relatively high humidity tends to hasten the sexual response.

Owing to its small size and simplicity of form, one of the aquatic seed plants, *Lemna major*, will be treated here with these species. Clark (12) has investigated the effects of intensity and daily duration of light on reproduction. Under suitable nutrient conditions the rate of reproduction was directly proportional to the light period including continuous illumination. At all day lengths reproduction was more rapid at 900 than at 400 foot-candles. Ashby (6) also investigated the interrelationship of intensity and duration of light in the growth of *Lemna*. Colonies were grown at constant temperature in a flowing nutrient solution with day lengths of 6 and 12 hr. and continuous light, at intensities of 350, 700, and 1400 foot-candles. At lower intensities light added as "duration" or as intensity has the same effect on growth. Under the conditions continuous light in all cases gave the highest growth rate. The rate of growth increases with increase in intensity of light up to 700 foot-candles, but falls off markedly at 1400 foot-candles. At all intensities the highest constants of body weight occur with the 6-hr. light period and the lowest with continuous light.

INTERNAL CONDITIONS OF THE PLANT IN RELATION TO PHOTOPERIODISM

Considerable research has been carried out on internal conditions of the plant associated with the photoperiodic response, primarily for the purpose of throwing light on the problem as to the mode of action of the light period in influencing growth and development. While the data obtained as a whole are of considerable interest in themselves, it must be admitted that relatively little progress has been made in determining the mechanism involved in photoperiodic response. In particular, no adequate explanation has been developed as to why a long day favors reproductive activity in one group of plants while a short day favors reproduction in a second group. Lubimenko and Szeglova (42) consider that a fundamental physiological distinction exists between the long-day and short-day plants in that the specific ratio of the energy of respiratory processes of oxidation to the photosynthetic processes of reduction is greater in the former than in the latter. However, it is to be recalled that frequently there is extensive storage of unused carbohydrate, with

or without flowering and fruiting, in plants of both groups, when they are exposed to a short day. These authors suggest that the striking effects of the light period are the result of a twofold action of light, first, its indirect action through the medium of carbohydrate produced in photosynthesis and, second, its direct activating effect on chemical reactions taking place in the embryonic tissue of the growing point.

That the contrast in response of long-day and short-day plants to length of day cannot be explained on the basis of photosynthesis alone is indicated by the fact that artificial illumination of exceedingly low intensity when used to lengthen the daily light period is capable of reproducing the characteristic formative effects of high-intensity long-day illumination. Moreover, Tageeva (70), in Maximov's laboratory, has made direct comparison of the intensity and the daily course of assimilation, as measured by absorption of CO_2 and increase in dry weight, in the oat (a long-day type) and millet (a short-day type) under natural growing conditions and exposed to a long day and a short day, respectively. There was no significant difference in the daily assimilation curves in the long-day and the short-day types of plant nor in assimilation intensity in the two types. It appears, therefore, that there is no definite relation between assimilation in the long-day and short-day plants and their photoperiodic responses. It was found, also, there is no fixed relation between assimilation intensity and the accumulation of dry matter in different day lengths. The sharp contrast in accumulation of dry matter between long-day and short-day types exposed to a long or a short day is due not so much to difference in working capacity of the chlorophyll apparatus as to difference in the utilization of the assimilate.

Considerable experimental work has been done to determine the applicability of the C/N ratio of Kraus and Kraybill. Auchter and Harley (7) found from preliminary studies that the short-day plant, Biloxi soybeans, which quickly flowered in a short day, contained at flowering time a relatively high percentage of total sugars and starch and a low percentage of total nitrogen. The plants exposed to the full summer day showed similar relations when they later reached the flowering stage in response to the decreasing length of day. Plants darkened at midday were much delayed in flowering and did not fruit, and in these plants the percentages of sugar and starch were low, the soluble nitrogen was low, but the insoluble nitrogen was relatively high. However, plants exposed to continuous light did not flower but, nevertheless, when analyzed were found to contain proportions of starch and total carbohydrates to nitrogen quite similar to those in the short-day plants. In experiments previously referred to, Gilbert (30) obtained in *Xanthium pennsylvanicum*, exposed to conditions of high temperature and short day or low temperature and long day, ascending C/N ratios as the plants approached flower-primordia formation.

Nightingale (51) found that in the short-day plants, salvia and soy beans, as well as in buckwheat, an indeterminate type, and the long-day plant, radish, assimilation of nitrate was restricted by a 7-hr. day, whereas a 6-hr. day did not greatly limit nitrogen assimilation in the indeterminate plant, tomato, provided available carbohydrate was present. In a 14-hr. day tomato made little growth and was unfruitful if the nitrogen supply was deficient, but it was vigorously vegetative and fruitful when nitrogen was freely supplied. When the same plants were transferred to a 6-hr. day, they elongated rapidly and flowered freely if nitrogen was still deficient, and associated with the increased growth the percentage content of carbohydrates decreased and that of nitrogen increased. If nitrogen was amply supplied both before and after the transfer, growth and flowering were checked, and associated with the decreased growth the percentage content of carbohydrates decreased and that of nitrogen increased. In a 6-hr. day the tomato plants were moderately vegetative and flowered freely when nitrogen was deficient but were weakly vegetative and unfruitful with nitrogen freely supplied. Transfer from the 6-hr. to the 14-hr. day, with deficient and with ample supplies of nitrogen, reversed the effects on growth and reproduction of the transfers from long to short day, and the associated changes in relative contents of carbohydrates and nitrogen also were reversed. In salvia exposed to a short day there was accumulation of carbohydrate, presumably because there was little utilization of it in synthetic processes. Transfer of high-carbohydrate salvia plants from a short to a long day resulted in rapid growth in association with loss of carbohydrates and increased assimilation of nitrates. The root system of weakly vegetative high-carbohydrate plants was relatively much more extensive than that of vigorously vegetative low-carbohydrate plants.

On the basis of observations made on *Phaseolus multiflorus* and data reported by others Tincker (72) concludes that there is a correlation between the C/N ratio and the behavior of the plant, though it does not follow that the magnitude of the ratio actually determines plant behavior, for the reverse may be true. It appears that length of day influences the rate of elongation of the stem and controls utilization of photosynthetic compounds, in this way influencing the C/N ratio of the tissues. In contrast with the conclusions of previous workers, Arthur and others (5), as a result of extensive observations on many species grown under accurately controlled conditions and exposed to various day lengths, were unable to find any relation between carbohydrate and nitrogen content and flowering in either long-day plants, such as radish and lettuce, or in the short-day plant, salvia, or in buckwheat, an indeterminate type. It was found that percentage content of carbohydrate and nitrogen in general can be changed by varying light intensity, length of day, and in some cases by changing the nitrogen supply,

though the range of variation of these two fractions depends upon the plant species. *Salvia* was prevented from flowering by supplementary night lighting which caused very little change in either the carbohydrate or nitrogen fractions. Even in tomato there appears to be little relation between the C/N ratio and the setting of fruit. In general, the percentage of carbohydrate increases and that of nitrogen decreases with increase in length of day, whereas flowering is initiated by a long or a short day, depending upon the species or variety.

As pointed out by Redington (60) and by Arthur and associates, in seeking an explanation of the action of day length on flowering it is necessary to take into consideration the fact that the photoperiodic response can be definitely localized in the plant. It has been shown by Garner and Allard (24) that with suitable technique flowering in response to a short day may be confined to certain branches or stems of the plant or in particular regions of the individual stem. Knott (37) has presented evidence to indicate that this effect can be sharply limited to the apex of the stem. Rasumov (59) also has confirmed and extended the results relating to localized action of day length. He finds that there is no specific plant organ for receiving the photoperiodic stimulation, which is more readily transmitted downward than upward in the plant. The underground tuber-forming portion of the plant receives the mutually opposed influences of parts receiving a long and a short day, and tuber formation takes place or is suppressed depending on relative intensity of the two influences. Redington suggests that the action of the light on the differentiating tissue must be a direct one and of a photocatalytic nature. Arthur and associates also conclude that the effect of light in initiating flowering may be directly upon the protoplasm of the cells at the growing point without perceptible change in chemical composition.

The mineral nutrition of the plant in relation to the length-of-day effect thus far has not received much attention. Borodin (10) has reported observations on the influences of variation in the supply of essential nutrients on photoperiodic response in the long-day plant, Mongolian barley, and in the short-day plant, Saratov millet. At a very early stage of development of water cultures of these plants the three elements, nitrogen, phosphorus, and potassium were singly withdrawn in parallel series. Separate groups of these cultures and the controls growing in a complete nutrient solution were exposed to day lengths of 18, 12, and 9 hr. The C/N ratios in the plants were determined by analysis at the tillering, shooting, and earing stages. In the long-day plant, barley, nitrogen deficiency increased the C/N ratio and accelerated initiation of the earing stage while phosphorus deficiency produced the reverse effect. Potassium deficiency delayed the earing stage under long-day conditions and the plants perished before reaching the earing stage in the short day. Nitrogen hunger induced ear formation in the

plants exposed to a 9-hour day although barley normally does not attain the earing stage when exposed to a short day. However, it was found that the C/N ratio fluctuates widely at the beginning of the earing stage under varying nutrition conditions and, in agreement with Arthur and associates, the author concludes that this ratio is not the immediate cause of the change from the vegetative to the reproductive stage, though it may be regarded as an attendant factor. As regards the short-day plant, millet, lack of nitrogen and potassium affected development as a whole and did not influence the throwing up of the panicle. Only lack of phosphorus, which strongly depressed growth, delayed appearance of the panicle. The conclusion drawn by Borodin would seem to approximately represent the present status of the problem of interrelation of the C/N ratio and the phenomenon of photoperiodism.

Tincker (74) has made a study of the influence of length of day in combination with variation in the supply of potassium upon the rate of accumulation of carbohydrates in the storage organs of *Phaseolus multiflorus*, *Dahlia*, and *Stachys tuberifera*. The rate of accumulation of these products in the roots and tubers was governed by the light period. Replacement of potassium by sodium was without much visible effect upon the rate of tuber formation, but in a short day lack of potassium caused less dry matter to pass to the underground structures. In all cases potassium accumulated gradually in the tubers.

In a study of hydrogen ion concentration of the cell sap in relation to the photoperiodic response Garner, Bacon, and Allard (28) showed that transfer of the short-day type of plant from a long day, in which the plant is vigorously vegetative, to a short day causes a sharp though temporary rise in the pH value which usually occurs after 3 to 5 days and is believed to indicate definite transition from the vegetative to the flowering condition. Acidity relations in long-day plants, as represented by *Rudbeckia*, when exposed to a long day are more or less similar to those found in short-day plants exposed to a short day. Similarly Knott (37) considers that transition from the vegetative to the reproductive stage is associated with decrease in catalase activity in the embryonic tissue involved. In a number of plant species studied Lubimenko and Szeglova (42) conclude that usually the chlorophyll content attains a maximum in an intermediate day length and decreases in either a longer or a shorter day. Murneck (50) found the same relative quantities of the chlorophylls *a* and *b* in the leaves of soy beans, cosmos, and salvia exposed to short and long days, and consequently in the reproductive and vegetative stages, respectively, but there was an increase in xanthophyll and carotin under the short-day conditions.

LENGTH OF DAY AS AN ECOLOGICAL FACTOR

The results of the extensive experimentation which has been carried out on the numerous ways in which the plant may be affected by relative

length of day and night naturally suggest that photoperiodism is often a factor of considerable importance in the varying behavior of a particular species or variety at different seasons of the year and in different latitudes as well as in the natural distribution of plants generally. Various angles of the subject have received the attention of investigators. However, approach to the problem by way of direct experimentation is made difficult by the fact that in nature the photoperiodic response is subject to modification by various other factors of the environment complex. Garner and Allard have emphasized the significance of the photoperiodic effect as explaining why some varieties of such warmth-loving summer plants as soy beans consistently are relatively early in maturing while others mature later. In soy beans changing day length apparently exercises a selective action on the early and late forms whereas differences in temperature seem to have much the same effect on both forms. It is considered that the chances for successful reproduction in this type of plant in a given region will depend largely on whether the day-length requirements are such as will permit completion of the reproductive process before frost in the fall.

From extensive observations on species differing widely in habitat Lubimenko and Szeglova (42) conclude that specific photoperiodic adaptation has developed under natural conditions of illumination during the period of vegetation and is dependent on the geographical latitude of the habitat. In general, tropical and subtropical plants are adapted to a short day and normally develop within a range of day length of about 10 to 14 hr.; Arctic species growing above a latitude of about 60° are adapted to a very long day; species of the temperate zone may be adapted to a relatively wide range in day length extending from the short day of spring and autumn to the moderately long day of summer. These authors remark that from the standpoint of general biology hereditary adaptation to length of day is extremely interesting, as a result of the direct action of the medium on the plant organism. This adaptation manifests itself as an entirely negative character, for it serves only to diminish the plasticity and cannot give any advantage to the plant.

Doroshenko (17) and Doroshenko and Rasumov (19) have made an interesting study of the day-length requirements of a variety of forms of wheat, barley, oats, rye, flax, beans (*Phaseolus*), peas (*Pisum*), and other species in relation to the geographical latitude of their origin. It was established that in general a definite relationship exists between response of a given form to day length and its origin with reference to latitude. Southern forms, which normally grow in days of shorter duration, for the most part are less retarded in attaining the reproductive stage and suffer less reduction in yield of seed when exposed experimentally to a shortening of the day than the northern forms which are accustomed to longer days. Wheat, oats, barley, and rye show these characteristics. In *Phaseolus* southern forms act as short-day plants and northern forms as

long-day plants. However, certain southern forms of flax were markedly retarded by a short day, and in *Pisum* certain southern forms suffered more from a short day than did the northern forms.

Kuznetzova (39) has made a study of the variation of the vegetation period as affected by geographical location, based on extensive experiments under the direction of Vavilov in which 185 winter and spring varieties of various cultivated plants, mostly pure lines, were grown at 115 stations representing all parts of the Union of Socialistic Soviet Republics during the period 1923 to 1927. The complete developmental period of the plant was divided into three phases: (a) from planting to appearance of the young shoots; (b) from appearance of the shoots to the flowering or earing stage; (c) from flowering or earing to ripening of the seed. The duration of the first phase is dependent on various environmental conditions, including those of a local, purely accidental character, the chief factors being temperature and rainfall. As regards duration of the second phase in relation to geographical location, all plants tested were found to fall into three groups: (a) those in which the time required for completion of this phase of development decreases with increase in geographical latitude (long-day plants); (b) those in which the duration of this phase decreases with decrease in latitude (short-day plants); (c) those which are only slightly affected by geographical factors (indeterminate or neutral plants). At the same latitude and with simultaneous planting the duration of the second phase is regulated chiefly by temperature. With equal conditions of temperature the duration of the second phase of development in different latitudes and in the same latitude but at different altitudes is determined by the number of hours of sunlight during the day. Other factors such as humidity, cloudiness, and soil fertilization play only an insignificant role in such principal phases of development as earing or flowering or they are of an accidental character. Within the species there is distinct relationship between the origin of each plant form and the degree to which it responds to geographical factors. With respect to the third phase of development the behavior of all plants is the same, the rate of development increasing with decrease in latitude and, likewise, with decrease in altitude. The degree of response, however, varies with the variety. The chief factors influencing geographical variation in the length of the third phase of development are temperature, rainfall, and relative humidity. In contrast with its outstanding importance in the second phase, light has no perceptible influence on the third phase of development. It is to be noted, however, that this latter conclusion is not entirely in accord with results reported by Garner and Allard and others.

To ascertain whether the length-of-day factor might be responsible for the fact that Australian varieties of wheat are early and do not succeed well in England and, similarly, that English varieties are late and give

unsatisfactory results in Australia, Forster and others (21) grew certain varieties from each country in different lengths of day at Wisley in England, Aberystwyth in Wales, and near Melbourne in Australia. The Australian varieties were found to be capable of exerting spikes under shorter periods of light than the British spring varieties which were later under all light periods. These results may partly explain the failure of British varieties in Australia where the summer-day length is much shorter. In experiments with woody species, conducted at Leningrad, to which reference already has been made (page 692), Mochkov found that in the natural full day *Salix lanata* L., a representative of high latitudes, ceased growth long before winter set in, while *Robinia Pseudo-Acacia* L., from lower latitudes, did not stop its growth till the branches were killed by frost. It is concluded that frost resistance, one of the chief factors determining the northward range of woody plants, depends to a considerable extent on response of these plants to length of day. To successfully withstand the winter they must terminate their vegetative activity in conditions of the normal full day before the advent of cold.

Since the range in the annual cycle of day length decreases with decrease in latitude, it might be expected that photoperiodism would become of less importance as an ecological factor as the tropics are approached. However, results of tests reported by McClelland (46, 47) in Puerto Rico, with an annual range in length of day only from 11 to 13.2 hr., would indicate that length of day is a factor of considerable importance even in tropical regions. It appears that some tropical species are sensitive to only slight changes in day length. Allard (4) recently has pointed out that, since the greatest variation in time of flowering among individuals of a population is shown near the critical day length for flowering and with day lengths well removed from the critical this variation largely ceases, attempts to secure strains or races of plants adapted to other latitudes logically should be based upon selection made near the critical period of light for flowering and fruiting. Laurie and Poesch (40) have done considerable experimentation in utilization of the length-of-day effect in producing flowering plants out of their normal season.

REFERENCES

1. ADAMS, J. The effect on certain plants of altering the daily period of light. *Ann. Bot.* **37**: 75-94. 1923.
2. ADAMS, J. Duration of light and growth. *Ann. Bot.* **38**: 509-523. 1924.
3. ALLARD, H. A. Gigantism in *Nicotiana tabacum* and its alternative inheritance. *Amer. Nat.* **53**: 218-233. 1919.
4. ALLARD, H. A. Length of day in relation to the natural and artificial distribution of plants. *Ecology* **13**: 221-234. 1932.
5. ARTHUR, J. M., J. D. GUTHRIE, and J. M. NEWELL. Some effects of artificial climates on the growth and chemical composition of plants. *Amer. Jour. Bot.* **17**: 416-482. 1930.

6. ASHBY, ERIC. The interaction of factors in the growth of *Lemna*. III. The interrelationship of duration and intensity of light. *Ann. Bot.* **43**: 333-354. 1929.
7. AUCHTER, E. C., and C. P. HARLEY. Effect of various lengths of day on development and chemical composition of some horticultural plants. *Amer. Soc. Hort. Sci. Proc.* 1924: 199-214. 1924.
8. BAILEY, L. H. Greenhouse notes for 1892-93. I. Third report upon electro-culture. *Cornell New York Agr. Expt. Sta. Bull.* **55**: 147-157. 1893.
9. BONNIER, G. Influence de la lumière électrique continué sur la form et la structure des plantes. *Rev. Gén. Bot.* **7**: 241-257, 289-306, 332-342, 409-419. 1895.
10. BORODIN, IRENE. The influence of nitrogenous and mineral nutrition on the time of heading in barley and millet under the conditions of different day length. *Bull. Appl. Bot., Genet. and Plant Breeding [Leningrad]* **27**: 171-195. 1931.
11. BREMER, A. H. Einfluss der Tageslänge auf die Wachstumphasen des Salats. *Genetische Untersuchungen. Gartenbauwiss.* **4**: 469-483. 1931.
12. CLARK, N. A. The rate of reproduction of *Lemna major* as a function of intensity and duration of light. *Jour. Phys. Chem.* **29**: 935-941. 1925.
13. CORBETT, L. C. A study of the effect of incandescent gas light on plant growth. *West Virginia Agr. Expt. Sta. Bull.* **62**: 77-110. 1899.
14. CRIST, J. W., and G. J. STOUT. Relation between top and root size in herbaceous plants. *Plant Physiol.* **4**: 63-85. 1929.
15. DEATS, MARIAN E. The effect on plants of the increase and decrease of the period of illumination over that of the normal day period. *Amer. Jour. Bot.* **12**: 384-392. 1925.
16. DEXTER, S. T. Effect of several environmental factors on the hardening of plants. *Plant Physiol.* **8**: 123-139. 1933.
17. DOROSHENKO, A. Photoperiodism of some cultivated forms in connection with their origin. *Bull. Appl. Bot., Genet. and Plant Breeding [Leningrad]* **17**: 167-220. 1927.
18. DOROSHENKO, A., E. D. KARPETCHENKO, and H. I. NESTEROV. Influence of the length of day on tuber set in potatoes and several other plants. *Bull. Appl. Bot., Genet. and Plant Breeding [Leningrad]* **23**: 31-60. 1929-1930.
19. DOROSHENKO, A., and V. J. RASUMOV. Photoperiodism of some cultivated forms in connection with their geographical origin. *Bull. Appl. Bot., Genet. and Plant Breeding [Leningrad]* **22**: 219-276. 1929.
20. ENOMOTO, NAKAE. On the physiological difference between the spring and winter types in wheat and barley. *Jour. Imp. Agr. Expt. Sta. Tokyo* **1**: 107-139. 1929.
21. FORSTER, H. C., M. A. H. TINCKER, A. J. VASEY, and S. M. WADHAM. Experiments in England, Wales and Australia on the effect of length of day on various cultivated varieties of wheat. *Ann. Appl. Biol.* **19**: 378-412. 1932.
- 21a. GARNER, W. W. Comparative responses of long-day and short-day plants to relative length of day and night. *Plant Physiol.* **8**: 347-356. 1933.
22. GARNER, W. W., and H. A. ALLARD. Effect of the relative length of day and night and other factors of the environment on growth and reproduction in plants. *Jour. Agric. Res.* **18**: 553-606. 1920.
23. GARNER, W. W., and H. A. ALLARD. Further studies in photoperiodism. The response of the plant to relative length of day and night. *Jour. Agric. Res.* **23**: 871-920. 1923.
24. GARNER, W. W., and H. A. ALLARD. Localization of the response in plants to relative length of day and night. *Jour. Agric. Res.* **31**: 555-566. 1925.
25. GARNER, W. W., and H. A. ALLARD. Photoperiodic response of soybeans in relation to temperature and other environmental factors. *Jour. Agric. Res.* **41**: 719-735. 1930.

26. GARNER, W. W., and H. A. ALLARD. Duration of the flowerless condition of some plants in response to unfavorable lengths of day. *Jour. Agric. Res.* **43**: 439-443. 1931.
27. GARNER, W. W., and H. A. ALLARD. Effect of abnormally long and short alternations of light and darkness on growth and development of plants. *Jour. Agric. Res.* **42**: 629-651. 1931.
28. GARNER, W. W., C. W. BACON, and H. A. ALLARD. Photoperiodism in relation to hydrogen-ion concentration of the cell sap and the carbohydrate content of the plant. *Jour. Agric. Res.* **27**: 119-156. 1924.
29. GILBERT, B. E. The response of certain photoperiodic plants to differing temperature and humidity conditions. *Ann. Bot.* **40**: 315-320. 1926.
30. GILBERT, B. E. Interrelation of relative day length and temperatures. *Botan. Gaz.* **81**: 1-23. 1926.
31. HARVEY, R. B. Growth of plants in artificial light. *Botan. Gaz.* **74**: 447-451. 1922.
32. JOHANSSON, NILS. Einige Versuche über die Einwirkung verschiedener Belichtung auf die vegetative Entwicklung von *Raphanus sativus* L. *Flora* **21**: 222-235. 1927.
33. KARLING, JOHN S. A preliminary account of the influence of light and temperature on growth and reproduction in *Chara fragilis*. *Bull. Torrey Bot. Club* **51**: 469-488. 1925.
34. KELLERMAN, K. F. A review of the discovery of photoperiodism: The influence of the length of daily light periods upon the growth of plants. *Quart. Rev. Biol.* **1**: 87-94. 1926.
35. KJELLMANN, F. R. Aus dem Leben der Polarpflanzen. pp. 443-521. In Nordenskiöld, Adolf Erik, Freiherr von: Studien und Forschungen veranlasst durch meine Reisen im hohen Norden. 521 pp.; Leipzig, 1885.
36. KLEBS, GEORG. Über die Blütenbildung von *Sempervivum*. *Flora* **11-12**: 128-151. 1918.
37. KNOTT, J. E. Further localization of the response in plant tissue to relative length of day and night. *Proc. Amer. Soc. Hort. Sci.* **23**: 67-70. 1926.
38. KONDO, M., T. OKAMURA, S. ISSHIKI, and Y. KASAHARA. Untersuchungen über "Photoperiodismus" der Reispflanzen. *Ber. Ohara Inst. Landw. Forsch.* **5**: 243-280. 1932.
39. KUZNETZOVA, E. S. Geographical variation of the vegetation period in cultivated plants. *Bull. Appl. Bot., Genet. and Plant Breeding [Leningrad]* **21**: 321-446. 1928-1929.
40. LAURIE, A., and G. H. POESCH. Photoperiodism—The value of supplementary illumination and reduction of light on flowering plants in the greenhouse. *Ohio Agric. Exp. Sta. Bull.* 512. 1932.
41. LINNÉ, CARL VON. Rön om växters plantering grundat på naturen. *Kungl. Svenska Vetenskapsakademiens Handlingar.* 1. 1739.
42. LUBIMENKO, V. N., and O. A. SZEGLOVA. L'adaptation photopériodique des plantes. *Rév. Gén. Bot.* **40**: 513-536, 577-590, 675-689, 747-764. 1928.
43. LUBIMENKO, V. N., and O. A. SZEGLOVA. Sur l'induction photopériodique dans le processus du développement des plantes. *Bull. Botan. Garden Leningrad* **1-2**: 1-52. 1931.
44. MAXIMOV, N. A. Importance in the life of the plant of the ratio between the length of the day and the night (photoperiodism). *Bull. Appl. Bot., Genet. and Plant Breeding [Leningrad]* **14**: 69-90. 1925.
45. MAXIMOV, N. A. Experimentelle Änderungen der Länge der Vegetationsperiode bei den Pflanzen. *Biol. Zentralbl.* **49**: 513-543. 1929.
46. McCLELLAND, T. B. The photoperiodism of *Tephrosia candida*. *Jour. Agric. Res.* **28**: 445-460. 1924.

47. McCLELLAND, T. B. Studies of the photoperiodism of some economic plants. *Jour. Agric. Res.* **37**: 603-628. 1928.
48. McPHEE, HUGH C. The influence of environment on sex in hemp *Cannabis sativa* L. *Jour. Agric. Res.* **28**: 1067-1080. 1924.
49. MOCHKOV, B. S. On the question of photoperiodism of certain woody species. *Bull. Appl. Bot., Genet. and Plant Breeding [Leningrad]* **23**: 479-510. 1930.
50. MURNEEK, A. E. The internal mechanism of photoperiodism. *Missouri Agric. Exp. Sta. Bull.* **310**: 44-45. 1932.
51. NIGHTINGALE, G. T. The chemical composition of plants in relation to photoperiodic changes. *Wisconsin Agric. Exp. Res. Bull.* **74**. 68 pp. 1927.
52. ODEN, SVEN. Plant growth in electric light. *Kungl. Landtbr. Akad. Handl. o. Tidskr.* **68**: 897-1057. 1929.
53. PFEIFFER, NORMA E. Microchemical and morphological studies of effect of light on plants. *Botan. Gaz.* **81**: 173-195. 1926.
54. RAMALEY, FRANCIS. Some caryophyllaceous plants influenced in growth and structure by artificial illumination supplemental to daylight. *Botan. Gaz.* **92**: 311-320. 1931.
55. RAMALEY, FRANCIS. A working bibliography of day-length and artificial illumination as affecting growth of seed plants. *Colorado Univ. Studies* **20**: 257-263. 1933.
56. RANE, F. WILLIAM. Electroculture with the incandescent lamp. *West Virginia Agric. Exp. Sta. Bull.* **37**. 1894. 27 pp.
57. RASUMOV, V. J. Über die photoperiodische Nachwirkung im Zusammenhang mit der Wirkung verschiedener Aussaattermine auf die Pflanzen. *Planta, Arch. Wiss. Bot.* **10**: 345-373. 1930.
58. RASUMOV, V. J. Influence of alternate day length on tuber formation. *Bull. Appl. Bot. Genet., and Plant Breeding [Leningrad]* **27**: 3-46. 1931.
59. RASUMOV, V. J. On the localization of the photoperiodical stimulation. *Bull. Appl. Bot. Genet., and Plant Breeding [Leningrad]* **27**: 249-282. 1931.
60. REDINGTON, G. The effect of the duration of light upon the growth and development of the plant. *Biol. Rev. and Biol. Proc. Cambridge Philos. Soc.* **4**: 180-208. 1929.
61. REDINGTON, G., and J. H. PRIESTLEY. A study of the effect of diurnal periodicity upon fibre production. *Leeds Philos. Soc. Proc.* **1**: 17-26. 1925.
62. SCHAFFNER, JOHN H. Sex reversal and the experimental production of neutral tassels in *Zea Mays*. *Botan. Gaz.* **90**: 279-298. 1930.
63. SCHAFFNER, JOHN H. The fluctuation curve of sex reversal in staminate hemp plants induced by photoperiodicity. *Amer. Jour. Bot.* **18**: 424-430. 1931.
64. SCHICK, R. Der Einfluss der Tageslänge auf die Knollenbildung der Kartoffel. *Züchter* **3**: 365-369. 1931.
65. SCHICK, R. Photoperiodismus (Sammelreferat). *Züchter* **4**: 122-135. 1932.
66. SCHÜBELER, F. CHR. The effects of uninterrupted sunlight on plants. *Nature* **21**: 311-312. 1880.
67. SIEMENS, C. WM. On some applications of electric energy to agricultural and horticultural purposes. *British Ass'n. Adv. Sci. Rep.* p. 474-480. 1881.
68. SIGMOND, HANS. Über das Aufblühen von *Hedera Helix* L. und die Beeinflussung dieses Vorganges durch das Licht. *Botan. Centralbl.* **46**: 68-91. 1929.
69. SMITH, FOLMER. Researches on the influence of natural and artificial light on plants. I. On the influence of length of day. *Meld. Norges Landbr. Hiskole* **13**: 1-228. 1933.
70. TAGEEVA, SOPHIE. Zur Frage des Zusammenhangs zwischen Assimilation und Ertragsfähigkeit. *Planta, Arch. Wiss. Bot.* **17**: 758-793. 1932.
71. TINCKER, M. A. H. The effect of length of day upon the growth and reproduction of some economic plants. *Ann. Bot.* **39**: 721-754. 1925.

72. TINCKER, M. A. H. The effect of length of day upon the growth and chemical composition of the tissues of certain economic plants. *Ann. Bot.* **42**: 101-140. 1928.
73. TINCKER, M. A. H. Contributions from the Wisley Laboratory: LIV. On the effect of length of daily period of illumination upon the growth of plants. *Jour. Roy. Hort. Soc.* **54**: 354-378. 1929.
74. TINCKER, M. A. H. The influence of the daily period of light and supply of potassium on the rate of growth of tubers and other storage organs. *Jour. Roy. Hort. Soc.* **57**: 326-331. 1932.
75. TOURNOIS, J. Influence de la lumière sur la floraison du houblon japonais et du chanvre. *Compt. Rend. Acad. Sci. [Paris]* **155**: 297-300. 1912.
76. WANN, F. B. Some of the factors involved in the sexual reproduction of *Marchantia polymorpha*. *Amer. Jour. Bot.* **12**: 307-318. 1925.
77. WEAVER, J. E., and W. J. HIMMEL. Relation between the development of root system and shoot under long and short day illumination. *Plant Physiol.* **4**: 435-457. 1929.
78. ZIMMERMAN, P. W., and A. E. HITCHCOCK. Root formation and flowering of dahlia cuttings when subjected to different day lengths. *Botan. Gaz.* **87**: 1-13. 1929.

Manuscript received by the editor June, 1933.

PLANT GROWTH IN CONTINUOUS ILLUMINATION

JOHN M. ARTHUR

*Boyce Thompson Institute for Plant Research, Yonkers, N. Y.**Plant growth in supplemental and continuous artificial light. Evidence of injury from continuous sunlight. General conclusions. References.*

The literature dealing with plant growth under continuous illumination falls naturally into three main divisions according to the light sources used. The divisions are: continuous natural sunlight, sunlight supplemented by artificial light for 12 hr. or longer each night, and continuous artificial light. The earliest observations on the effect of continuous light on plants were concerned entirely with plants growing in continuous sunlight in the Arctic regions. Observation and experimentation in the other two main divisions obviously began only with the development of high-intensity light sources which approached sunlight in brilliancy and which could be maintained over a considerable period of time.

At an early date European travelers within the Arctic circle were impressed with the rapid growth of plants during the long days as compared with that of similar species growing farther south. In this connection the observations of Linnaeus, in 1739, as quoted by Smith (27) are of interest: "Slowness of growth corresponds to the length of summer nearer the poles, however, not entirely; because toward the poles the summer is shorter but also has longer days and the plants thrive and grow by the heat of the sun. In Paris the summer is longer than in Lapland; therefore the plants ripen later in France than in Lapland, the length of time being counted from the appearance of the shoots until they bear ripe fruit. In Paris the cool nights are longer, during which time the plants rest; wherefore they also need more days to ripen. In Lapland there is so to speak no night during the summer, therefore plants can grow both day and night. For example: In 1732 grain sown May 31st was mown ripe July 28th, maturing in 58 days. Rye sown May 31st, 1732, was mown August 5th, maturing in 66 days. This took place in Luleå, Lapmarek, and could not have happened farther south."

Schübeler (25), in 1880, also observed the remarkable development of plants under continuous sunlight during the short summers of the Arctic regions. More recently Albright (1, 2) has called attention to the rapid development of grain, potatoes, and various species of vegetable-

garden plants growing in northwestern Canada near the mouth of the Mackenzie River to a point 80 miles north of the Arctic circle. The mean July temperature in this region varies from 56.6°F. at Aklavik to 59°F. at Fort McPherson. This compares with a similar mean of 68.8°F. at Ottawa, Canada, and according to the New York Observatory records, a mean for New York City for 64 years of 75°F. Twelve to 24 in. below the surface the soil remains permanently frozen. Yet on account of the long days of sunlight many plants grow very rapidly and manage to mature in the short growing season. Crops such as the potato, favored by comparatively low temperatures and long days thrive especially well in this region. Albright records a single tuber grown at Fort Good Hope in 1927 which weighed 17 ounces. Higgins (14) of the Motanuska Alaska Station reports potato yields on well-fertilized land ranging up to 412 bushels per acre depending upon the variety grown. Other garden plants, such as beets, turnips, peas, and cabbage, grow remarkably well there.

Darrow (8) has recently called attention to the records of the rapid growth of tomatoes and berries in Alaska. Albright (1, 2) has presented numerous instances of grains and other crop plants developing at an ever-increasing rate when the height growth at a southern station is compared on the same day with that at a station farther north. Evans (9) found that timothy plants propagated vegetatively from the same plant and grown at various stations from Savannah, Georgia, to Fairbanks, Alaska, reached the flowering stage at a constantly accelerated rate from southern to northern stations. A late variety in 1929 flowered at Jackson, Tennessee, on July 5, at Beaverlodge, Alberta, Canada, July 10, and at Sitka, Alaska, August 2nd. Local temperature and soil conditions affect the time of maturity of plants at such widely separated points of observation. In addition the temperature is lower in the early spring and late summer in the north. Even in July, the month when all temperatures at the various stations should be most nearly alike, northern stations have the disadvantage of a slightly lower temperature as compared with those farther south. Yet because of the longer days in the north, plants reach maturity at about the same time, or at most only a few weeks later than similar varieties growing in the south. Probably a much more accurate test of the effects of continuous sunlight could be obtained by growing the same varieties of plants in greenhouses at each station where temperature and soil factors could be more carefully controlled. Then only the one main factor, sunlight, would need to be considered in studying the growth rate produced. To date greenhouse facilities in the far north have not been available for such a comprehensive series of experiments so that this study must be left for the future. It should be pointed out, however, that the studies already cited indicate clearly that plants develop much more rapidly on long days; the longer

the day, apparently the faster the rate, and further, that there is no definite indication of injury from exposure to continuous sunlight. This is not true of plants grown under artificial light in more carefully controlled environments.

PLANT GROWTH IN SUPPLEMENTAL AND CONTINUOUS ARTIFICIAL LIGHT

The first study of the effects of electric light on plant growth was recorded in 1861 by Herve Mangon (16). Seedlings of rye grown in darkness were exposed to an arc lamp for 11 to 12 hr. each day for 4 days. The plants developed chlorophyll and bent toward the light, reacting in the same way as when exposed to sunlight. Prillieux (21), in 1869, observed that green shoots of the water plant *Elodea canadensis* gave off bubbles of oxygen gas when exposed to the light from either arc lamps or gas lamps. He concluded that photosynthesis took place in artificial light the same as in sunlight but to a lesser degree on account of the lower intensity of artificial light. Siemens (26), in 1880, was probably the first to grow plants under continuous artificial light. He used a carbon-arc lamp with an output of 1400 candle power. His comments regarding the experiments are of interest: "I was induced to look for interesting results in these experiments on account of the great abundance of blue and actinic rays in the electric arc, upon which its value in photography depends. In experimenting with powerful electric lamps for illuminating purposes I have been struck, moreover, by the action produced upon the skin, which is blistered, without the sensation of excessive heat at the time, an effect analogous to that produced by solar rays in a clear atmosphere."

Siemens first used the arc lamp over a greenhouse for a few hours each night. He found that even though the light had to travel through the glass wall of the globe enclosing the arc and the glass roof of the greenhouse, it still produced an effect on plant growth equal to about one-half that of sunlight. Believing that the open arc would be more effective when placed directly over plants in the greenhouse, he made tests with cucumber and melon plants exposed at a distance of 1 meter. Siemens observed that the plants developed considerable leaf injury at 1 meter when exposed to the naked arc, but when the distance was increased to 1.5 to 2.3 meters no further injury developed, and those plants which were injured produced new leaves and subsequently recovered. Plants were then exposed for 11 hr. each day to daylight and again to 11 hr. each night to electric light for a 4-day period. The plants after this treatment he observed far surpassed the control plants receiving only daylight in both general appearance and amount of green pigment produced. His further conclusion is of special interest: "These experiments are not only instructive in proving the sufficiency of electric

light alone to promote vegetation, but they also go to prove the important fact that diurnal repose is not necessary for the life of plants, although the duration of the experiments is too limited perhaps to furnish that proof in an absolute manner. It may, however, be argued from analogy, that such repose is not necessary, seeing that crops grow and ripen in a wonderfully short space of time in the northern regions of Sweden and Norway, and Finland, where the summer does not exceed two months, during which period the sun scarcely sets."

In 1891, Bailey (4) reviewed the literature on the growth of plants as related to artificial light and added further experiments on the growth of lettuce, radish, and other plants under a combination of daylight supplemented by artificial light. He observed that great injury developed on plants exposed to the naked arc, but when exposed to an arc enclosed in a glass globe there was little injury. Lettuce heads developed fully two weeks earlier with supplementary lighting. A second report was published in 1892 (5).

In 1894, Bonnier (6) studied the structure of leaves and stems of Arctic plants and compared these with Alpine plants growing at approximately the same temperature but the first under continuous sunlight, the other on a normal day of high intensity. The leaves of Arctic plants were thicker but less differentiated in structure. The palisade cells were not well developed but the mesophyll tissue was of open structure and well developed in Arctic plants. The epidermis and cuticle were thinner in Arctic plants. The question of light intensity as well as day length, however, should be considered. Although the Arctic day is continuous, the intensity is much lower than the Alpine day and the characteristics found in the Arctic plants are similar to those of shade plants. In 1895, Bonnier (7) made a series of very critical experiments aimed at separating the two effects of light intensity and continuous illumination. He used, as a light source two 8-amp. arc lamps in glass globes having a low ultra-violet transmission. Plants were exposed continuously for several months in one series and were compared with a series exposed for 12 hr. and then held in darkness for 12 hr., and again compared with a series growing in a greenhouse in normal sunlight. Intensity was increased by bringing the lamps closely together, arranging reflecting mirrors around the plants, and shortening the distance from the plants to the lamp. The shortest distance used was 0.5 meter, the the greatest distance was 6 meters. Continuous illumination at low intensity as compared with an alternation of 12 hr. light with 12 hr. darkness, produced plants with more chlorophyll and less differentiation of leaf tissue, that is, with a poorly defined palisade layer and thin epidermis. Higher intensities produced the same effect. He concluded that the structural changes produced by continuous illumination were due to the continuity of the light and were independent of both its nature and

intensity. He described the effect of continuous illumination on plants as a "green etiolation" (*étiolement vert*) and stated that this compared favorably with the structure and appearance of Arctic plants harvested at Spitzbergen.

Unfortunately Bonnier used only two light sources in his studies, sunlight and the arc lamp. The arc lamp approaches sunlight very closely in quality. The conclusion, therefore, that the structural changes produced are independent of the nature of the light, in the sense of quality or wave-length distribution, is not justified. Popp (20) showed that removing the blue and all wave-lengths shorter than 5290 Å from sunlight produced a type of etiolation characterized by thin stems and thin leaves, both poorly differentiated, structurally. Smith (27), using both incandescent filament lamps and Arctic sunlight, compared barley plants exposed continuously with those grown on shorter day lengths and found no indication of "green etiolation." On the contrary, the green tissue produced is described as "nicely green, but a little light" on the 6-hr. day plants and "deep and glossy green without any visible difference" in the 12-, 18-, and 24-hr.-day groups. The incandescent filament lamp has much more red and infra-red and much less blue than either the carbon-arc lamp or sunlight. Harvey (13) grew a number of varieties of plants exposed continuously to filament lamps. Potato, tomato, and other plants grown at an intensity of 380 lumens per square foot (380 foot-candles) grew well but were somewhat taller than normal, while plants grown at an intensity of 680 lumens per square foot appeared much more normal. Guthrie (12), using filament lamps, found that either increasing the day length toward continuous illumination or removing the blue region from the solar spectrum resulted in a decrease in chlorophyll. Johnston (15) observed that plants grown under an energy distribution including the visible and infra-red were not so green as those receiving only visible light with the red region further decreased by a red infra-red absorbing filter. Arthur recently grew buckwheat plants for two weeks under continuous illumination, using in one case a 1000-watt incandescent filament lamp. Adjoining this, with only a sheet-metal baffle between, a similar set of plants was grown under a 25-amp. carbon-arc lamp. The tests were made in the constant condition room at the Boyce Thompson Institute for Plant Research. An attempt was made to adjust the distance of the two lamps so that the total energy at the soil level was the same. On account of the inconstancy of the flaming arc and the deposit of inorganic material from the carbons on the glass globe enclosing the arc, it was found impossible to maintain the same total energy relations. The intensities, however, were comparable. The leaves of the plants grown under the filament lamp were light green in color in contrast with those grown under the arc lamp which were very dark green in color. It is certain, therefore, that both the quality

and the intensity of light produce characteristic changes in chlorophyll pigmentation and internal structure of leaves and other plant organs, so that the differences observed by Bonnier in the case of plants grown under continuous illumination cannot be attributed wholly to the continuity of the light. Since Bonnier did not record the intensity of illumination in his experiments, it is possible that the highest intensity used was yet sufficiently low to produce some etiolation effects, although considering the distance of the lamps from the plant (0.5 meter) this does not seem probable. Maximov (17) studied the growth of plants under continuous illumination using 500- and 1000-watt filament lamps. He compared the leaf structure with that of plants grown under alternating illumination of 12 hr. light and 12 hr. darkness and found greater differentiation of palisade and mesophyll tissue under continuous illumination. This is in direct contrast to the work of Bonnier.

Pfeiffer (19) studied the structure of leaves and stems of plants grown both under continuous artificial light and on a 19-hr. day, 12 hr. of which were sunlight. Incandescent filament lamps of 1000- or 1500-watt current consumption were used in this work. She found that continuous artificial illumination reduced the thickness of leaves; while some varieties of plants grown on the 19-hr.-day conditions had thicker leaves, others had thinner leaves. Higher carbon dioxide concentrations tended to increase leaf thickness. The thickness of the palisade layers of cells in general followed closely the leaf thickness, showing less palisade development in thinner leaves. No marked variations in the spongy mesophyll layers of cells or in the epidermal layers were noted. Stomatal counts were highest under the 19-hr.-day conditions with higher carbon dioxide concentrations and least under continuous artificial illumination. In the case of buckwheat plants grown on 5, 7, 12, 17, 19, and 24-hr. days of artificial light, the maximum height and stem diameter were reached on a 17-hr. day; also the maximum amount of xylem development. Both the 19-hr. day and continuously illuminated plants, as well as those grown on shorter day lengths, showed correspondingly less of the highly differentiated tissues.

Arthur, Guthrie, and Newell (3) studied the growth of several species of plants under artificial light alone and in combination with sunlight. An attempt was made in this work to grow plants throughout their life history with photosynthesis at or near its maximum rate by supplying a high light intensity and long day along with increased carbon dioxide concentration and a relatively high temperature. A chemical analysis of many of the plants was made to determine the carbohydrate relations to increasing length of day and increasing light intensity. Height growth and weight of tissue produced were also recorded. In general, carbohydrates and weight per plant increase with day length up to the point where foliar injury begins to be effective in holding the plants

back. This point was usually a 17- or 19-hr. day, although in case of tomato at high intensity the point is reached on an even shorter day. Some plants grown under artificial light, such as the tomato, geranium, and coleus, were especially sensitive to long days of 17, 19, and 24 hr. At low intensities, in case of the tomato, the weight of tissue produced increased with increasing day length up to a 17- or 19-hr. day, while at higher intensities the peak was reached on a 12-hr. day. Cabbage plants were found to increase in weight of tissue produced and in total carbohydrate with length of day up to 17 or 19 hr., followed by a decrease on continuous illumination. The dry weight of tissue produced increased regularly with day length in many of the common grains and forage crops such as barley, clover, wheat, and buckwheat up to a 17- or 19-hr. day and decreased again on continuous illumination. While many of these plants were able to withstand continuous artificial illumination, they were always found to produce at a maximum on a shorter day length, usually on 17 to 19 hr. The best growth and dry-weight production was obtained in the greenhouse with 12 hr. of sunlight supplemented by 6 hr. of artificial light each night and with carbon dioxide at about 10 times the normal concentration. That is, an 18-hr. day, 12 hr. of which was sunlight, was found to be the most effective of all the lighting combinations studied. Continuous illumination which was made up of 12 hr. of sunlight supplemented by 12 hr. of artificial light each night was not so effective. The tomato was greatly injured by this combination, while geranium and coleus, the two other species which did not withstand continuous artificial illumination, withstood the combination successfully. In this work it is evident that long continuous exposure of plants to the incandescent filament lamp produces a foliar or other injury on many plants which is reflected in less dry weight production. Sunlight is a much better light source for growing plants than the incandescent filament lamp and has a definite balancing effect when used in combination with supplementary artificial light.

Since the tomato plant was found to be the most sensitive to continuous illumination of all plants studied by Arthur, Guthrie, and Newell, it furnishes a good test plant for further work on the effects of quality of light on plants. These authors used carbon arc lamps and mercury-vapor lamps in combination with filament lamps in further tests with tomato under continuous illumination. Arc lamps were found to retard the rate of development of the injury but the final result was the same as under the filament lamps. Lower light intensities produced the injury at a much slower rate but produced greater height growth, weaker stems, and other etiolation effects. Recent correspondence with parties in both northern Canada and northern Sweden has established the fact that tomatoes have been grown successfully, to the production of ripe fruit, in both of these places at points within the Arctic circle on the

continuous sunlight which obtains in these regions during the short summer season. Attention has been previously directed to the records of the growth of tomatoes in Alaska (8). This is further evidence that sunlight is a better light source than the artificial light which has so far been used in the growth of plants. Much more work needs to be done on both the quality and intensity of light which is best suited to plant growth. When this information is available, it will be possible to choose a light source, or combination of light sources, which is much nearer the ideal for plant growth. It is possible that sunlight is not ideal for the growth of plants; on the other hand, it is established that sunlight is a better source than most of our common electric lamps.

Roodenburg (23) has tested the effects of neon gas discharge tubes on the growth of plants and compared the rate of development with plants grown under both filament and mercury-vapor lamps. Because of the output of neon tubes in the red region near the main absorption band of chlorophyll, Roodenburg believes this light source will have some practical significance in plant production. Intensities produced by the consumption of 75 watts per square meter he found sufficed for forcing several varieties of plants as compared with an energy consumption of 300 to 400 watts per square meter when incandescent filament lamps were used. He found the mercury-vapor-arc lamp useful in supplying sufficient blue light to prevent excessive stem elongation but questions its practical value as a high intensity is required which means higher current consumption.

Oden (18) has studied the growth of a number of plants under incandescent filament lamps on various day lengths up to and including continuous illumination. His studies were designed to work out (intensity \times time of illumination) relations for commercial plant production. The time was varied from 3 to 24 hr. and the highest intensity used was 120 gm. cal. per day. This intensity was not sufficient for many of the plants studied but was sufficient for sweet peas and certain varieties of beans. He found that a current consumption of 200 to 500 watts per square meter was necessary to grow plants from seed but a lower intensity could sometimes be used for forcing flower production. He has included an extensive bibliography of 422 references on light relations in general. Ramaley (22) has also published a general bibliography on this subject and Schratz (24) has published a review and bibliography on the effects of artificial light on higher plants.

EVIDENCE OF INJURY OF CONTINUOUS SUNLIGHT

Smith (27) has published a bibliography including many citations on the effects of day lengths and has studied the growth of plants in various day lengths including continuous illumination in a series of experiments extending from Aas, Norway, at latitude $59^{\circ} 40'$ through Tromsøe,

latitude 69° 39', to Kingsbay, Spitzbergen, latitude 79°. He also used artificial light alone and as a supplement to daylight. After considering his own work and the published data of others, Smith came to some very interesting conclusions: day length had an effect on "development" or progress toward the flowering stage and also on "growth" as measured by dry-weight production, height of plant, internodal length, and leaf size. The rate of development per light unit for cereals (barley, oats, and rye) reached a maximum on an 18- or 24-hr. day, while peas reached a maximum on a 6-hr. day. Light intensity he found affected both dry-weight production and development, but especially the dry weight, while day length affected both rate of development and dry-weight production, but especially rate of development. "Growth" (measured by dry-weight production, etc., as already defined) per day, per hour of illumination or per light unit was found to have a "maximum displacement," that is, the maximum growth for young plants was found on a 24-hr. day or continuous illumination, while the maximum growth as the age of the plant increased was displaced toward shorter day lengths. Smith found the "maximum displacement" generalization to hold whether artificial or sunlight was considered. There is, therefore, some evidence that long exposure to continuous illumination even in sunlight operates in a way which eventually checks growth and dry-weight increase. This might indicate either that plants need a period of rest in darkness of 5 to 6 hr. in each 24-hr. period, or that growth is attuned to a progressive falling off in day length as the growing season progresses. The latter relation would not appear extraordinary since Garner and Allard (10, 11) have already shown that plants are attuned to flower on definite day lengths as the growing season progresses. Using continuous artificial light, Arthur, Guthrie, and Newell (3) found that the tomato developed the first signs of foliar injury in an exposure of 5 to 7 days. This would indicate that the tomato needed a rest period in each 24-hr. day rather than a progressive falling off in day length, but since the quality of light used in this work is known to be more injurious than sunlight, the evidence is not clear. It has been pointed out in previous considerations that the tomato can be grown in continuous sunlight within the Arctic circle. It may be, therefore, that even the tomato will fit into the generalization that plants are attuned to a progressive falling off in day length during the growth period starting with continuous illumination when a light source is used which is less injurious.

GENERAL CONCLUSIONS

It is evident from the foregoing discussion that growth rate and dry-weight production of plants are rapidly accelerated by increasing the length of day. This is true when either sunlight, artificial light, or

various combinations of the two are considered. There is definite evidence that many plants are injured by continuous artificial light and many plants produce at their maximum on a 17- to 19-hr. day as contrasted with the 24-hr. day under the intensity and quality so far used in the artificial illumination of plants. An 18-hr. day, 12 hr. of which are sunlight and 6 of which are high-intensity artificial light, is better than an 18-hr. day of all artificial light. This indicates that sunlight is better in quality for plant growth than many of our common artificial light sources. In the experiments where plants were grown in ever-increasing day lengths of sunlight up to and including continuous illumination, the evidence is not so clear, since temperature and other factors were not well controlled in these experiments. There is some evidence, however, to indicate that plant production of dry weight is eventually checked even under continuous sunlight conditions, so that plants produce most abundantly on a slightly shorter day. That is, while growth and dry-weight production proceed at first at a more rapid rate on a 24-hr. day, as the plants age this point of maximum rate of production shifts to a 17 or 19-hr. day. This indicates that plants need either a period of rest of 5 to 7 hours in each 24-hr. period or that they are attuned to the falling off of the length of day which normally obtains in nature during the growing season. Further experiments with other growth factors, such as temperature well controlled, are needed to determine these responses.

REFERENCES

1. ALBRIGHT, W. D. Gardens of the Mackenzie. *Geograph. Rev.* **23**: 1-22. 1933.
2. ALBRIGHT, W. D. Crop growth in high latitudes. *Geograph. Rev.* **23**: 608-620. 1933.
3. ARTHUR, JOHN M., JOHN D. GUTHRIE, and JOHN M. NEWELL. Some effects of artificial climates on the growth and chemical composition of plants. *Amer. Jour. Bot.* **17**: 416-482. 1930. (*Also in Contr. Boyce Thompson Inst.* **2**: 445-511. 1930.)
4. BAILEY, L. H. Some preliminary studies of the influence of the electric arc lamp upon greenhouse plants. New York [Cornell] *Agric. Exp. Sta. Bull.* 30. 1891.
5. BAILEY, L. H. Second report upon electro-horticulture. New York [Cornell] *Agric. Exp. Sta. Bull.* 42. 1892.
6. BONNIER, GASTON. Les plantes arctiques comparées aux mêmes espèces des Alpes et des Pyrénées. *Rév. Gén. Bot.* **6**: 505-527. 1894.
7. BONNIER, GASTON. Influence de la lumière électrique continue sur la forme et la structure des plantes. *Rév. Gén. Bot.* **7**: 241-257; 289-306; 332-342; 409-419. 1895.
8. DARROW, G. M. Tomatoes, berries, and other crops under continuous light in Alaska. *Science* **78**: 370. 1933.
9. EVANS, MORGAN W. Relation of latitude to time of blooming of Timothy. *Ecology* **12**: 182-187. 1931.
10. GARNER, W. W., and H. A. ALLARD. Effect of the relative length of day and night and other factors of the environment on growth and reproduction in plants. *Jour. Agric. Res.* **18**: 553-606. 1920.

11. GARNER, W. W., and H. A. ALLARD. Further studies in photoperiodism, the response of the plant to relative length of day and night. *Jour. Agric. Res.* **23**: 871-920. 1923.
12. GUTHRIE, J. D. Effect of environmental conditions on the chloroplast pigments. *Amer. Jour. Bot.* **16**: 716-746. 1929. (*Also in Contr. Boyce Thompson Inst.* **2**: 220-250. 1929.)
13. HARVEY, R. B. Growth of plants in artificial light. *Bot. Gaz.* **74**: 447-451. 1922.
14. HIGGINS, F. L. Report of the Agronomist. *Rept. Alaska Agric. Exp. Sta.* 1931, 1932.
15. JOHNSTON, EARL S. The functions of radiation in the physiology of plants. 2. Some effects of near infra-red radiation on plants. *Smithsonian Misc. Coll.* **87** (14). 1932.
16. MANGON, HERVE. Production de la matière verte des feuilles sans l'influence de la lumière électrique. *Compt. Rend. Acad. Sci. [Paris]* **53**: 243. 1861.
17. MAXIMOV, N. A. Pflanzenkultur bei elektrischen Licht und ihre Anwendung bei Samenprüfung und Pflanzenzüchtung. *Biol. Zentralbl.* **45**: 627-639. 1925.
18. ODEN, SVEN. Växtodling I Elektriskt Ljus. *Kungl. Landbruksakademiens och Tidskrift* **69**: 213-224. 1930.
19. PFEIFFER, NORMA E. Microchemical and morphological studies of effect of light on plants. *Bot. Gaz.* **81**: 173-195. 1926. (*Also in Contr. Boyce Thompson Inst.* **1**: 123-145. 1926.)
20. POPP, H. W. A physiological study of the effect of light of various ranges of wave length on the growth of plants. *Amer. Jour. Bot.* **13**: 706-736. 1926. (*Also in Contr. Boyce Thompson Inst.* **1**: 241-271. 1926.)
21. PRILLIEUX, ED. De l'influence de la lumière artificielle sur la réduction de l'acide carbonique par les plantes. *Compt. Rend. Acad. Sci. [Paris]* **69**: 408-412. 1869.
22. RAMALEY, F. A working bibliography of day-length and artificial illumination as affecting growth of seed plants. *Colorado Univ. Studies* **29**: 257-263. 1933.
23. ROODENBURG, J. W. M. Kunstlichtcultuur. [With a summary in English.] *Landbouwhoogeschool te Wageningen, Laboratorium voor Landbouwplantenteelt* No. 14. Wageningen. 1930.
24. SCHRATZ, EDUARD. Einfluss künstlicher Beleuchtung auf höhere Pflanzen. *Züchter* **3**: 45-57. 1931.
25. SCHÜBELER, F. C. The effect of uninterrupted sunlight on plants in the Arctic regions. *Nature*: Jan. 29, 1880.
26. SIEMENS, C. W. On the influence of electric light upon vegetation, and on certain physical principles involved. *Proc. Roy. Soc. [London]* **30**: 210-219. 1880.
27. SMITH, FOLMER. Researches on the influence of natural and artificial light on plants. 1. On the influence of the length of day—preliminary researches. *Meld. Norg. Landbukshoiskole* **13**: 1-228. 1933.

Manuscript received by the editor January, 1934.



XXI

THE EFFECTS OF LIGHT INTENSITY UPON SEED PLANTS

HARDY L. SHIRLEY

*Lake States Forest Experiment Station, Forest Service, United States
Department of Agriculture*

Introduction. Influence of darkness on plants: Effect of darkness on growth, form, and structure—Effect of darkness on composition—The influence of light on etiolated plants—Miscellaneous effects of darkness—Theories as to the cause of etiolation. The effect of light intensity upon plants: The “light-growth reaction”—The effect of light intensity upon the growth and development of plants—Light intensity and mineral nutrition—The influence of light intensity on flowering—The influence of light intensity upon transpiration, winter hardiness, and resistance to drought—Minimum light requirements. Summary. References.

INTRODUCTION

This section is devoted chiefly to the effects of radiation within the visible region, λ 4000 to 7200 Å, or “light” upon plants. However, the term “light” is frequently used in a more general sense, *i.e.*, in speaking of sunlight we generally mean total solar radiation, and in speaking of artificial light we mean the total radiation of the source in question. Unless otherwise qualified, “light” in this section will be used to designate the total radiation from the source used. A discussion of the methods and instruments available to the worker in the field of radiation, as well as the variability of radiation and other factors are considered in another section of this survey. It should be emphasized here, however, that, in examining the work in this field, the experimental technique available to the worker must be constantly kept in mind and the results weighed accordingly. When the difficulties involved in studying the influence of light on plants are fully appreciated, it is little wonder that we find in the literature many contradictions and many opposing theories.

INFLUENCE OF DARKNESS ON PLANTS

Darkness, or zero light intensity, produces in plants an effect known as etiolation, the general features of which are familiar to all plant workers. The typical characteristics of etiolation were described by John Ray in 1686. From his time on, many botanists have studied etiolated plants. The general features of etiolated plants are described in textbooks on plant physiology and morphology, such as Strasburger (102), Benecke-Jost (9), Haberlandt (44), Goebel (39), and Sachs (88). MacDougal (65) made a comprehensive review of the literature dealing

with etiolation from 1686 to 1900. The reader is referred to these works for reviews of the earlier literature.

EFFECT OF DARKNESS ON GROWTH, FORM, AND STRUCTURE

In studying the phenomenon of etiolation, it must be borne in mind that the fully etiolated plant is one which has developed in complete darkness. Friedel (36) demonstrated that there was a pronounced difference between plants developed in absolute darkness and those developed under bell jars covered with black paper. Lentils in complete darkness had smaller leaves, fewer internodes, and less angular stems than those grown behind black screens. He found absolutely no chlorophyll development in the onion in complete darkness, while other, less careful workers, had previously reported that the onion could produce chlorophyll in darkness. Likewise, exposure to light only a few minutes each day for the purpose of examination will greatly modify the form of the plant (76, 113).

The typical etiolated plant is white or yellowish in color, has long internodes, undeveloped leaves, thin watery sap, and, in general, relatively undifferentiated tissues.

MacDougal (65), during a period of seven years, cultivated 97 different species in darkness. Particular care was taken to exclude light from his cultures. Although the different species presented several unique reactions to darkness, certain features were common to all. The outstanding features which he observed in practically all higher plants were tall, weak, attenuated stems, and thin only partially unfolded leaves; in fact, in many plants the only sign of foliar development was a distinct plumular hook. The microscopic structure of stems and leaves showed that the different tissues present in normal plants were generally present also in etiolated plants, but the cells were usually thin-walled, loosely organized, and less distinctly differentiated. Darkness appeared to arrest development so that many tissues which form later in the life of the plant were not present in etiolated forms. Similar structural differences have been reported by practically all workers on etiolated plants (114, 76, 78, 105, 89).

Some of the special features observed by MacDougal are worthy of note. Plants developed from root storage organs, in general, were able to live longer in the etiolated state, and produced greater growth than seedlings. In fact, some of them were capable of going through a complete vegetative cycle in the dark and developed new storage organs at the end of the season. *Arisaema triphyllum* which develops new corms each season was capable of four successive seasons of activity in darkness. The corms and other storage organs produced in the dark were smaller and more watery but similar in structure to such organs developed in normal plants; however, the shoots produced from such etiolated storage

organs were progressively more attenuated than those from normal organs. The length of time which plants may be kept growing in darkness depends upon the amount of stored food available and also on the temperature at which they are grown. At high temperatures the plants exhaust the food supply more rapidly. MacDougal kept plants grown from root-storage organs alive for as long as 18 to 20 months. Plants grown from seed, on the other hand, generally succumbed in much shorter periods, owing to lack of stored food; however, a seedling of the coconut palm lived 15 months in darkness and still had exhausted only half the endosperm.

Leaves of monocotyledons with parallel veins tend to elongate in darkness at the expense of growth in width. They are frequently rolled or folded. Plants with open or netlike venation usually develop excessively long petioles in the dark, with small narrow leaves, often more or less folded (65, 77, 89). Climbing plants and tendrils have a tendency to elongate excessively in darkness and seldom develop the typical corkscrew growth of plants grown in the light. If the tendrils are placed in contact with a support, they will make one or two turns around it but then continue to elongate (65).

Plants grown from buds, corms, or other organs in which the leaf, stem, and flower primordia are laid down the previous season, tend to produce all these organs in darkness the first season of etiolation. Plants grown from seed, or storage organs formed while the plant was kept in the dark, do not develop flowers, nor do they usually attain the same stage in development attained by normal plants during the same period (65).

Some unusual structural features were noted by Brown (16) in etiolated shoots of *Opuntia Blakeana*, a prickly pear cactus. The etiolated stems were rounded or oval in cross section, as noted by MacDougal (65). The epidermal cells were elongated, especially near the apex of the joints. The cuticle was very thin, or absent, the cortical layer weakly developed, and the palisade tissue imperfectly organized. Under the epidermis, in normal plants, there is a row of cells containing crystals of calcium oxalate. These crystals were absent in etiolated shoots. Of particular interest were the modifications of the stomata. In normal plants these are sunken below the surface, while in etiolated shoots he observed that they were raised above the surface on minute papillae composed of from 6 to 12 cells or more. These papillae were apparently formed from the stomatal mother cell which continued division, instead of dividing only once, to form the guard cells. The guard cells were elongated and wedge-shaped in the etiolated shoots. Some well developed stomata were found beneath the cortical layer. Etiolated shoots, exposed to full sunlight, were severely injured at first. There was a breaking down of both epidermal and interior cells. After a few days' exposure, however, they soon developed a cuticle and the cortical cells

and palisade tissue assumed more normal proportions. Eventually they attained a structure similar to normal plants.

In anatomical structure etiolated stems show an arrested development. Priestley and Ewing (78) noted that stems of potato (*Solanum tuberosum*) and broad bean (*Vicia Faba*) tended to develop in darkness a structure comparable to that of roots. Dyes injected in etiolated plants could not be forced into the meristematic growing points, while in normal stems the dye readily penetrated the meristem to the surface. They concluded that the failure of the growing apex to unfold and develop normally was due to the lack of nutrition caused by the impermeability of the meristem tissue. The meristem is rich in proteins and fats, which probably accounts for its impermeability to nutrient sap.

Priestley (77), in a later paper, stated that the general anatomy of *Vicia* and *Pisum* remained unaltered in darkness except that the third and further internodes did not develop but remained curled up in the plumular hook. The diameter of the stele was much smaller in proportion to the diameter of the stem in etiolated plants. Exposure to light for one hour daily caused a considerable expansion in the stele, but it was still not so large as in a normal plant. In the shoots the stele was bounded first by a starch sheath which was later replaced by a primary endodermis. This starch sheath and primary endodermis appeared to contain fatty substances in the cell wall which rendered them more or less impermeable. It was impossible to plasmolyze the differentiated cortical cells of plants grown completely in the dark, but after brief daily exposures to light these cells plasmolyzed readily. There was considerable starch in the etiolated shoot which was concentrated just below the meristematic apex. Upon exposure to light this disappeared very rapidly. He concluded that the main morphological structure of etiolation is determined by a disturbance of growth at the shoot apex, which is caused by the relative impermeability of the cell walls between vascular strands and those of the meristem. These cells contain protein and fatty substances that form the surface of the protoplast.

That exposure to light increases the permeability of protoplasm to dyes has been confirmed by many workers. Lepeschkin (58), by shading portions of *Elodea* leaves with tinfoil, demonstrated that this effect, too, is local in its action, that it increases with intensity up to a certain point (10 per cent of total sunlight or less in Arizona), and that it reacts very quickly to changes in light. Plants taken from the same light conditions and placed for 2 hr. in different light conditions show tremendous differences in dye absorption.

In discussing the growth of plants in darkness and in light of varying intensities, it is necessary to differentiate between elongation, expansion of foliar organs, and increase in total plant substance (dry weight).

Plants grown in darkness frequently elongate more rapidly than those given daily exposures to light, and if abundantly supplied with reserve food, they may attain a greater total length. Foliar expansion, on the other hand, is inhibited by darkness.

Figdor (34) studied the influence of light on the structure of a South African lily (*Bowica volubilis*). This plant sends up a shoot from an underground bulb. When grown in light, the shoot has a primary axis and a number of side shoots. When grown in darkness, the primary shoot develops about the same as in light, but the secondary shoots remain short and undeveloped. Etiolated plants are generally very succulent and hence much lower in percentage of dry matter than those developed in light. The total dry weight produced by etiolated plants is, of course, less than that of the seed or vegetative organ from which they are grown, since some carbohydrate materials must be used up in respiration, and not all of the dry material in the seed or primary organ is available for the production of new growth.

Etiolated plants grown for the same length of time and at the same temperature as comparable green plants grown in the light will, of course, be lower in total dry weight because they are deprived of the products of photosynthesis. Whether light exercises a stimulative effect upon the rate of utilization of stored food material in seeds or other organs is still open to question. Lubimenko and Karisnev (63) studied the initial rate of growth (dry-weight basis) of seedlings of certain cereals under different intensities of daylight and in almost complete darkness. They also followed the loss in weight of the residual seed. The plants in light not only increased more rapidly in dry weight than those in darkness, but they also tended to exhaust the seed more rapidly. They concluded that light produces a direct action on the accumulation of dry matter in plants during their purely "saprophytic" nutrition. Shirley (95) conducted a similar experiment on maize seedlings, except that he had no plants in complete darkness. He also found that seedlings in the light exhausted the seed more rapidly than those in very weak light (too low in intensity for appreciable chlorophyll formation); however, the temperature was also higher in the light. When plants in light and in darkness were grown at the same temperature, no difference could be found in the rate of utilization of the stored products in the seed nor, during the first 5 days, in the weight of the seedling. Thereafter, the seedling in the light increased in dry weight more rapidly, but this is attributed to the products of photosynthesis. It is unfortunate that Lubimenko and Karisnev did not have accurate temperature control and that Shirley did not make tests in the absence of carbon dioxide. Further work on this problem should also be accompanied by chemical analysis of the seed and seedling.

EFFECT OF DARKNESS ON COMPOSITION

Plants developed in darkness tend to be higher in percentage moisture and in soluble nitrogen and carbohydrates than plants developed in the light. MacDougal (65) found that the percentage moisture in the tops and corms of *Arisaema* was greater in etiolated plants than in normal ones, and greater in plants with two seasons' growth in darkness than in those with one season's growth without light. The proportion of ash to other dried materials was higher in the etiolated plants. Lubimenko and Karisnev (63) found the tops of wheat seedlings developed in darkness to have 4.62 per cent soluble carbohydrates, while those in the light had 2.87 per cent. Soluble carbohydrates were also higher in the residual seed of the etiolated seedlings than in those developed in light.

Schulz and Thompson (92) made chemical analysis of barberry shoots grown in light-tight boxes placed over field plants. Moisture, starch, reducing sugar, sucrose, water-soluble nitrogen, and ash content, based on percentage of dry weight, were higher in the etiolated shoots than in normal ones. Fats, as determined by ether extract, and hemicellulose were the only substances determined which were approximately the same in both green and etiolated plants. No difference could be determined in the composition of the roots, nor was the stored material appreciably reduced, even though considerable quantities of etiolated sprouts developed. The old tops were removed from all plants used in this test, and apparently the test did not run sufficiently long for the new green tops to begin storing materials in the roots. The higher percentage of solutes in the dry material of etiolated sprouts is a result, in part, of the lower content of insoluble carbohydrates.

The ability of plants to use nitrates in darkness to form asparagin was demonstrated by Suzuki (104) who used potato shoots detached from the tuber and cultivated in sugar solution. Tokarewa (108) analyzed etiolated lupine seedlings for nitrogen content. Substantial quantities of asparagin and small amounts of creatinin and betaine were found. Plants containing a considerable amount of asparagin had no carnosin. Asparagin has also been found in etiolated soy bean seedlings by Schulze (91) and in etiolated maize seedlings by Jodidi (53). Jodidi (52, 53) studied the chemical composition of etiolated corn seedlings during the first few days following germination and also the composition of the ungerminated seed. Proteins were rapidly used up by the seedlings so that after 8 days as much as 48 per cent of them were converted into soluble nitrogen compounds. From the second to the eighth day the distribution of nitrogen in the aqueous extract changed as follows: (a) Amide nitrogen increased from 11.44 to 18.08 per cent. (b) Humin nitrogen decreased from 19.51 to 6.45 per cent. (c) Amino nitrogen

increased from 20.83 to 29.55 per cent. (d) Peptide nitrogen decreased from 34.06 to 27.52 per cent.

He interpreted these results as indicating that acid amides increase at the expense of certain amino acids such as tryptophane and tyrosin, while amino acids increase at the expense of the polypeptides.

Nightingale and Schermerhorn (71) grew asparagus shoots, from root stocks of plants formerly grown in light, in quartz sand irrigated with nutrient solutions with and without nitrogen. Some of the plants were grown in the greenhouse and others in darkness. Plants in darkness not only absorbed nitrates but from them built up higher nitrogen compounds, a process which was accompanied by a decrease in carbohydrates in the root. Nitrates were abundant in the absorbing roots of both the plants in light and of those in darkness but were not found in the shoots except after active growth had ceased. In the plants grown without nitrates, no nitrates were found; but there was a considerable amount of soluble nitrogen in the shoots and a corresponding decrease in the nitrogen of the root. Reid (80, 81, 82) demonstrated that seedlings and cuttings could assimilate nitrates and use them to build up growth-promoting substance in darkness, provided they had a high carbohydrate and low nitrogen reserve. On the other hand, growth of seedlings from seeds having a high protein and low carbohydrate reserve was not favored appreciably by addition of nitrates to the nutrient media.

Excised tips of roots and of shoots of corn, peas, and cotton were cultured by Robbins (83) in mineral nutrient solutions containing 2 per cent glucose, or levulose. The cultures were maintained under sterile conditions and kept in darkness. Under such conditions considerable growth took place, but practically none occurred in cultures which contained no carbohydrates. The shoots had the characteristics of etiolated shoots—small leaves, yellow color and excessive elongation. Robbins and Maneval (84) grew, in light and darkness, excised root tips in modified Pfeffer's solution containing 80 and 400 parts per million of autolyzed yeast, and also in solutions containing 2 per cent glucose. Those in the light survived longer (one for 149 days) and produced more tissue, as measured by length of main axis, number of secondary roots, and total dry weight.

Wilson (121) cultivated vetch seedlings in darkness on a sterile agar nutrient medium containing sugar. After 2 days these test cultures were inoculated with the nitrifying bacterium, *Rhizobium leguminosarum*. After 36 days the plants were examined for nodule formation. Nodules were found in all cultures but were more prevalent in those supplied with 0.5 and 1.0 per cent saccharose. The plants without sugar died first, but even with these one nodule was found. The media containing 0.5 and 1.0 per cent saccharose proved to be more favorable for the growth of etiolated seedlings than those containing the same percentages of

levulose and dextrose. Two per cent sugar was less favorable than 1 per cent.

Etiolated leaves were found to be lower in manganese content than green leaves (10). This held true not only for leaves of dandelion cultivated in darkness, as contrasted with those of the same species grown in light, but also for the interior leaves of head lettuce, cabbage, chicory, and celery, as contrasted with the exterior leaves. They also found the white portions of the variegated leaves of *Aucuba japonica* to have a lower manganese content than the green portions of the same leaves. Manganese content seemed to be correlated with chlorophyll content.

Eisenmenger (30) placed one-month-old tobacco plants in darkness, and after 11 days compared their chemical composition with similar plants left in light. Total nitrogen, nitrate nitrogen, and amino nitrogen were higher in the plants in darkness. The plants in darkness did not live long enough to exhaust the original nitrogen content to any appreciable extent.

Cannon (18) studied the effect of light and darkness on the rate of oxygen absorption by roots. *Helianthus annuus* and rooted cuttings of *Salix laevigata* were grown in Knop's solution, then transferred to distilled water for testing. The plants were given from 2 to 4 tests in one day, one or more in darkness, and the others in full sunlight, or sunlight passing through a bell jar. The tests were of from 1½ to 3 hr. duration. Of the 53 tests run, 60 per cent showed less oxygen absorption when the shoot was in the light than when in darkness. When his results are analyzed statistically,¹ the oxygen absorption of sunflower in light proves to be less than that in darkness by odds of over 20:1. For willow there is no significant difference. Since oxygen absorption by roots increases with temperature and transpiration, and since both of these were higher in the light, he concluded that exposure of tops to light *per se* tends to decrease the rate of oxygen absorption by the roots. It is possible that oxygen liberated in the photosynthetic process may tend to depress the rate of oxygen absorption by roots.

THE INFLUENCE OF LIGHT ON ETIOLATED PLANTS

When etiolated plants are brought into the light, they begin to develop the characteristics of normal green plants. The leaves unfold and expand rapidly, they develop chlorophyll, and differentiation—if not too long arrested—takes place (65, 89). Schönfeld (89) germinated and grew plants in darkness, samples of which were removed after definite intervals and placed in the greenhouse. Measurements of the length of the petiole, length of leaf blade, and width of blade, were made on all plants each time a sample was removed. Plants contin-

¹ Statistical analysis was made by Shirley.

nously in the dark, if grown from seeds or root stock well supplied with reserve foods, develop excessively long petioles, and in monocotyledons long leaf blades. The leaves of dicotyledons were shorter, and all leaves were narrower in the dark. After placing in the light, all leaves grew in breadth, and petiolate leaves grew also in length. Even leaves which had ceased growth in the dark resumed growing when placed in the light. The ability of the leaf or leaf part to renew growth in light, after cessation in darkness, depended upon the relative age of the tissue in question. The youngest tissues, relatively, grew the most, and were able to resume growth after the longest period of interruption. For this reason, leaves partially developed in darkness and then removed to light never developed the same shape and relative proportion as leaves exposed to daylight from the beginning.

The effect upon etiolated plants of short daily exposures to light was intensively investigated by Trumpf (113) and Priestley (76). Trumpf found that the form developed by the bean plant *Phaseolus multiflorus* depended upon the amount of radiation received, *i.e.*, that within the limits of his experiment, for a constant value of the product of intensity times time a definite form of plant was produced. Plants exposed for 3 hr. daily at 6600 meter-candles (613 foot-candles) had essentially the same dimensions as those exposed for 40 min. daily at 30,000 meter-candles (2787 foot-candles). However, this was not true of chlorophyll content. The plants with long daily exposures to light at low intensities developed chlorophyll, whereas those which received the same amount of light but in short exposures to high intensities developed no chlorophyll. After 12 days' growth with 40 min. daily exposures to 30,000 meter-candles, the plants were placed in daylight but still failed to produce chlorophyll, while those exposed to low intensities produced abundant chlorophyll in daylight. Excised leaves of the chlorotic plants developed a deep green color and increased in size after 2 days' exposure to daylight when placed in a weak solution of cane sugar.

Trumpf further demonstrated that the influence of light in determining the form of the plant was independent of its photosynthetic action. The evidence for this is that plants placed in an ice box at 7°C. and exposed to light for short periods and also plants exposed, while under the influence of narcotics, developed the same form as those exposed to light in free air at room temperature, regardless of the fact that no growth occurred while the plants were in the ice box or under the influence of narcotics.

Priestley (76) grew plants in light-tight chambers placed in an underground cellar having no window. Special precautions were taken to exclude extraneous light. The chambers were provided with 0.5-watt nitrogen-filled lamps of about 80 candle power, which were operated by a timing switch so that four conditions of lighting were obtained, as

follows: (a) 1 hr. of light each day, (b) 10 min. of light each day, (c) 2 min. of light each day, and (d) continuous darkness.

An illumination period of even 2 min. daily was sufficient to cause a profound change in the plants. *Vicia Faba* and *Pisum sativum* lost their typical plumular hook, and the lateral leaves began to unfold. With 10 min. exposure the leaves had attained a size almost as large as those exposed to 1 hr. of light. Those receiving 1 hr. of light daily developed chlorophyll. Plants grown in the light for a while and then placed in darkness soon developed the typical plumular hook and other features of etiolated plants. The light used by Priestley was much lower in intensity than that used by Trumpf. Both of these experiments clearly demonstrate the need for extreme care in excluding all light from etiolated plants if true etiolation effects are to be obtained.

MISCELLANEOUS EFFECTS OF DARKNESS

Light not only has an influence upon the plant organs subjected to its action but also an indirect action on the underground portions of plants. Observing plants grown in nutrient solutions in which both roots and shoots were subjected to illumination or kept in darkness, Probst (79) found that during the first few days shoot growth was greater in cultures in which both root and shoot were in darkness. In every case the shoot or root was longer in darkness. Illuminating the shoot caused an increase in root growth, but illuminating the root caused only a slight change in shoot growth. Increasing the humidity stimulated both the root and shoot growth. Experiments with oats showed that continuous illumination of the root caused an initial stimulus of shoot growth, followed later by decrease in growth. Exposure to darkness after the roots had been in continuous illumination caused a certain stimulation in shoot growth; however, such plants never grew so rapidly as those in which the root had not been illuminated. Long periods of illumination, or even continuous illumination of *Avena* coleoptiles and of *Lepidium* shoots produced no visible influence on the growth rate of the root, but with *Sinapis*, darkening the shoot after a period of continuous illumination caused a decided acceleration in root growth. His final conclusions were that illuminating the shoots inhibited shoot growth but increased root growth, while illuminating the root inhibited root growth and, in most cases, shoot growth also.

Some very interesting experiments on the effects of light on the nutrition economy of seedlings and cuttings have been conducted by Reid (80, 81, 82). By choosing seeds and cuttings having a wide variation in the composition of their organic reserves and by cultivating these in nutrient media with and without nitrates, she was able to demonstrate that some of the differences between etiolated and normal plants attributed to the action of light are, in fact, the result of differences in the

nutritional balance. For instance, seedlings from seeds very low in protein but high in carbohydrates, when grown without nitrates, attain greater size and weight in darkness than in light. When nitrates are supplied, the reverse condition prevails. Nitrates were assimilated in darkness and were converted into growth-promoting substances; however, the extent of this process was limited by the carbohydrate supply. Nitrate utilization was always greater when the plants were provided with both light and carbon dioxide. Shoot growth, at the expense of root growth, was favored by a relatively low ratio of carbohydrates to nitrogen, while with high ratios the relationship was reversed. This held true regardless of whether the carbohydrates and nitrogen were supplied by the seed or by photosynthesis and nitrates. A limited nitrogen supply caused seedlings to mature rapidly in light, while an abundant nitrogen supply favored vegetative activity. In all cases, secondary thickening of stems, roots, and cell walls was favored by light. Reserve carbohydrates were accumulated more rapidly in seedlings with a limited nitrogen supply. An increase in carbon dioxide content above that of normal air tended to accentuate the effects observed from photosynthesis, *viz.*; increased root growth, especially in plants from high-protein seeds but without nitrates; increased shoot growth, when nitrates were supplied, which was more pronounced with seedlings from low-protein seeds when deprived of external nitrogen. Cow peas and soy beans grown in light without carbon dioxide had roots of almost the same weight as plants grown in darkness, while high- and low-protein corn seedlings had greater root development in light, as did also sunflower and muskmelon seedlings. Leaf development was greater in light than in darkness, even though carbon dioxide was excluded in the former. Best development occurred when both light and carbon dioxide were added.

Mason (67) reports interesting studies on the effect of light on the growth of the date palm. The leaves of this plant elongate rapidly at night but scarcely at all during the day. Under bright sunlight no growth could be detected. On cloudy days partial growth occurred. Mason enclosed these leaves in light-tight boxes and found that the growth could be started or stopped at will by closing the box or opening it to direct sunlight. In order to demonstrate the complete dependence of growth upon light, he placed electric lamps in the box and illuminated the plants at various times during the day and night. At first only small incandescent lamps were used. Normal growth occurred under such conditions regardless of the time when the plants were illuminated. When illumination from lamps of 1800 watts total capacity was provided, growth was greatly inhibited but not entirely stopped. When a mercury arc in a lead glass tube was used, growth was completely inhibited. Evidently the failure of ordinary incandescent lamps to inhibit growth was due to their low intensity in the blue and near the

ultra-violet region. Light of wave-lengths greater than 5700 \AA evidently has very little action in inhibiting growth.

Trumpf (114) illuminated leaves and petioles of the bean plant while the epicotyl remained in darkness. The leaves developed like those of fully illuminated plants, while the epicotyl developed like that of a completely etiolated plant. Similarly, illuminating the epicotyl had no effect on the leaves. When one portion of a leaf or epicotyl was illuminated while another portion remained in darkness, the portion in darkness developed somewhat similarly to that in the light. The light effect, therefore, is local in its action and cannot be transferred from an irradiated organ to one kept in darkness. From his experiments it is possible to conclude that the action of light on one part of an organ may affect other parts of the same organ, but whether or not this actually occurs cannot be detected without more refined methods of examination than he used.

Coupin (25) reported that lentils germinated in darkness in a horizontal position continued to develop horizontally, *i.e.*, they showed no response to gravity. Since this plant produces runners which grow horizontally, he assumed that the stem in darkness takes on the form of a runner. Whether this actually occurs is open to considerable question since weakness of the stem, injurious effects of illuminating gas, or other factors may have influenced his results.

THEORIES AS TO THE CAUSE OF ETIOLATION

Numerous theories have been advanced by early workers to explain etiolation, many of which are discussed by MacDougal (65). Sachs considered etiolation to be pathological, although etiolated plants become normal in light. Kraus explained the failure of leaves to grow in darkness by postulating that they could use for growth only substances manufactured locally. Godlewski assumed etiolation to be a response of the plant to overcome temporary obstructions. Palladin thought that etiolation might be caused by the lack of sufficient transpiration in darkness. MacDougal attributed to light a morphogenetic influence which causes the differentiation and development of the various plant organs. Without light, development is arrested. He thought of light as having a stimulative action which does not need to act directly upon a particular tissue but could be transmitted from the illuminated parts to those held in darkness.

Coupin (24) added to the cultural solution in which etiolated plants were growing a sterilized and filtered extract from green plants. Such an extract inhibited stem elongation of the etiolated plants more than a similar extract prepared from etiolated plants. He concluded, therefore, that plants develop a substance in light which determines their

growth form and that this substance will react on etiolated plants to make them resemble those grown in the light.

Trumpf (114) repeated this experiment and pointed out that the osmotic concentration of the expressed sap of normal plants is much higher than that of etiolated plants. When the sap of normal plants was diluted to the same osmotic concentration, it caused even less retardation of growth than that of etiolated plants. The sap of both types of plants inhibited the growth of etiolated seedlings and the extent of this inhibition varied directly with the concentration of the sap in the culture solution.

Trumpf's (113) experiments clearly demonstrate that etiolation is not a result of lack of chlorophyll, or lack of photosynthesis, since it was possible to produce plants normal in form with no chlorophyll. Furthermore, his experiments (114) demonstrate that the action of light is local and that this effect cannot be transferred from an illuminated organ to one remaining in darkness.

Priestley and Ewing (78) and Priestley (77) have shown that there is an accumulation of protein and fatty substances in the meristem which renders it impermeable to the nutrient sap, and they have concluded that etiolation is a result of nutritional disturbances in the meristematic tissue. This impermeability of the protoplasm (cf. Lepeschkin, 58) of meristematic tissue in darkness can explain many of the phenomena connected with etiolation; however, root and stem growth take place in darkness in a manner similar to that in light.

Finally, there is the question of the usefulness of etiolation to the plant. It is evident that excessive stem elongation, together with positive phototropism or geotropism does serve a very useful purpose in elevating the growing point from darkness to a point where it may enjoy favorable light conditions. This reaction is valuable in enabling the plant to emerge from among obstructions in the soil as well as to attain quickly a position favorable for photosynthesis. The failure of leaves to expand in darkness is an economy in the use of reserve foods, particularly carbohydrates. However, in many cases no useful purpose whatsoever appears to be served by etiolation.

THE EFFECT OF LIGHT INTENSITY UPON PLANTS

The influence of light intensity upon plants cannot be considered independently of the time during which any given intensity acts. For instance, as pointed out in the foregoing section, Trumpf (113) has shown that the stage in morphological development attained by etiolated bean plants exposed to light depended upon the total amount of light received. Chlorophyll formation, on the other hand, was greater when the plant was exposed for long periods at low intensity than when exposed to the same total amount of light at higher intensities. Likewise, tests on the

effects of very short daily exposures to light, which frequently are carried on in conjunction with experiments on photoperiodism, have revealed many of the same characteristics exhibited by plants grown with insufficient intensity. Before proceeding with a discussion of the effects of radiation intensity *per se* on the growth of plants, a consideration of the effects of definite quantities of light on plants will be given, as well as the effects of sudden illumination or darkening of plant organs.

THE "LIGHT-GROWTH REACTION"

Every plant and plant organ goes through a definite period of growth during which the growth rate gradually increases to a maximum, and then diminishes to zero. The descending limb of the growth curve is usually steeper than the ascending limb. This is spoken of as the grand period of growth. In the discussion which follows, the different investigators are referring to disturbances in the grand period of growth induced by the action of light.

In 1914, Blaauw (11), working with sporangiophores of *Phycomyces nitens* found that exposures to light caused a profound influence upon the rate of elongation. After exposure there was an initial stimulation in growth, followed by a depression. The time interval between exposure and reaction decreased, while the depth of the depression and height of the maximum increased with increasing amounts of light from 1 up to 210 meter-candle-seconds. For 240,000 to 1,920,000 meter-candle-seconds, secondary minima and maxima appeared, which tended to cause the rate of growth alternately to increase and decrease in a wave-like manner. He concluded that a given amount of light calls forth a typical growth reaction in the cell and that this reaction runs a definite course.

Similar experiments were carried out by Blaauw (12) with seedlings of *Helianthus globosus*. With these plants, exposure to light caused a depression in the rate of growth, with a minimum after 41 to 51 min. for low amounts of light—14 to 26 min. with large amounts—followed by a return to the original rate of growth. In all other respects, the response was similar to that with *Phycomyces*. When exposed to continuous light of 1 to 4096 meter-candles, a similar response occurred. The response started after 2 to 8 min., the time interval being shorter, the higher the intensity; the minimum was attained at 25 to 30 min. The rising limb of the curve showed secondary minima at the higher intensities. From these facts he deduced the theory that phototropic bending depended upon the differences in the light-growth reactions caused by different intensities of light.

Vogt (118) carried out similar studies on the coleoptile of *Avena sativa*. When exposed to continuous light of 5, 25, 100, and 1000 meter-candles, the coleoptiles completed their growth progressively earlier and

their total lengths were correspondingly less, being 84, 80, 75, and 62, respectively, based on their growth in darkness as 100. Measuring the growth rate every 3 min. he found that exposures to intensities less than 1500 meter-candles for periods up to 15 min. caused first a depression in growth, followed by an acceleration; whereas exposures to intensities of 12,000 to 400,000 meter-candles caused an immediate increase in growth rate during the first 3 min. of exposure, followed by a decrease below the original rate. He found the same responses reported by Blaauw for exposures to continuous light. Preliminary illumination at 5 meter-candles did not change the course of the response to higher intensities. Plants kept in light and exposed to a short period of darkness showed a stimulation in rate of growth. Sudden changes in temperature also caused the growth curve to exhibit an undulating character.

Sierp (97) confirmed Vogt's work that the *Avena* coleoptile continued growing longest in darkness and that the length of the growth period and total length of the coleoptile decreased with increasing light intensity. This held true for plants illuminated from the start and also for those given illumination after having grown for different lengths of time in darkness. In his experiments he measured the rate of growth only at intervals of 1 hr. or more; hence he did not detect the variations occurring in shorter intervals. The response he noted was not the typical light-growth reaction of Vogt and Blaauw.

In a later paper, Sierp (98) measured the growth rate at shorter intervals and was able to observe the typical light-growth reaction when the coleoptiles were exposed to only 100 meter-candle-seconds, 2 sec. at 50 meter-candles, or 10 sec. at 10 meter-candles. Weak responses occurred to light as low as 10 meter-candles for 1 sec.

This wave-formed growth curve was produced not only by exposures to light, but also by exposing the plants to the narcotic action of ether, or to a shock (99). While exposed to vapors of ether, the plants were still able to give a typical light-growth response when exposed to light. When etiolated coleoptiles were exposed to less than 100 meter-candle-seconds they tended to show first a maximum at 40 min. and a minimum later at 100 min. As the amount of light was increased to 3000 meter-candle-seconds, the light-growth reaction changed so that the minimum occurred first at 30 min. and the first maximum at 70 min. The peaks and depths of the curve increased with increasing amounts of light. When the growing tips were covered with tinfoil the typical light-growth reaction was pronouncedly disturbed, and frequently did not occur at all, whereas darkening the growing region tended only to delay the beginning of the reaction.

By covering the growing region with tinfoil bands and caps, Sierp and Seybold (100) showed the light sensitivity, as measured by the time required for the initiation of phototropic bending, to vary greatly from

tip to base. The first 0.25 mm. proved to be 40 times as sensitive as the region 0.25 to 0.5 mm. This region was 6 times as sensitive as the region 0.5 to 0.75 mm. The sensitivity continued decreasing until beyond 2 mm. it was only $1/36,000$ that of the tip. By excising 1, 2, and 4 mm. of the tip of coleoptiles, they found that the rate of growth was diminished the greater the length of tip removed and also the higher the intensity of light to which they were exposed.

Koningsberger (54) showed that preliminary illumination at a low intensity did not prevent a typical light-growth reaction at a higher intensity; in fact, the reactions caused by the two different intensities proceeded simultaneously, but the magnitudes of the maxima and minima were dependent upon the higher intensity. By varying the exposure intervals it was possible to produce curves in which the peaks of one reaction corresponded to the troughs of another and thus produce the typical interference phenomenon in the resulting growth curve.

With a comprehensive series of experiments on the light-growth reaction of *Avena Dillewijn* (29) presented experimental evidence confirming Blaauw's hypothesis as to the nature of phototropic movement, and explaining through the light-growth reaction why the type of response given varied with the intensity of the light. He showed that at low intensities there was a long-period light-growth reaction, while at higher intensities the reaction had a much shorter period, from trough to trough. The light-growth reactions for different zones of the coleoptile tip were also determined for different intensities. If the subapical regions (0 to 2 mm.) of plants from darkness are exposed to continuous illumination, a decrease in growth rate ensues, and this is followed by a return to the initial rate. Plants in continuous light when darkened showed first an increase in growth rate, followed by a return to the original rate. A short exposure to light caused first a decrease (the light response), followed by an increase above the original rate (the dark response). Dillewijn measured the changes in permeability of hypocotyls of *Helianthus* caused by exposures to light. A wave-formed curve resulted which resembled somewhat the short-period light-growth curve; however, more experiments will be needed to establish the correlation between the two.

Erman (31) confirmed the findings of Vogt to the effect that immediately after exposure to light there was a decided stimulation in rate of growth for the first 3 min. Generally the maximum rate of growth occurred during the first minute of illumination. Even 1 sec. of exposure was sufficient to cause a response. Erman also showed that the sensitivity to light varied in different varieties of *Avena*.

Blaauw (13) found a retardation in elongation of roots of *Sinapis alba* when exposed to intensities of 1500 meter-candles of continuous illumination. Roots of *Raphanus sativus* gave no reaction even when

exposed to 2000 meter-candles for 2 hr. Similar negative results were shown by roots of *Avena sativa* and *Lepidium sativum*.

Jeffs (51), studying the influence of light on the rate of elongation of root hairs of *Raphanus sativus* and *Sinapis alba*, found no indication of a light-growth reaction for these cells. The light values used varied up to 3,153,600 meter-candle-seconds. He concluded that such a reaction probably depends upon changes in cell division rather than on changes in cell elongation.

The true nature of the light-growth reaction has not yet been revealed and probably awaits a more refined experimental technique in order to determine just what happens in the cell during the first few minutes as well as to determine the outward manifestation of this reaction. Apparently a change in permeability and also a change in turgor are involved. However, it is safe to conclude that exposures to light, even if of very brief duration, do set up rhythmical changes in growth rate. The type and magnitude of the light-growth reaction are dependent upon the intensity and duration of the light exposure. This reaction is intimately connected with phototropic movements. When acting continuously, light tends to hasten the maturation of plant organs and to produce a concomitant decrease in size. The magnitude of these effects increases with increasing intensity of light. Most roots are apparently insensitive to the light-growth reaction, as are also root hairs.

THE EFFECT OF LIGHT INTENSITY UPON THE GROWTH AND DEVELOPMENT OF PLANTS

General Statement.—The gross effects of variations in light intensity upon the growth of plants were well known to early botanists and have been described in the textbooks on general botany, plant physiology, and ecology. Attention in this section will be confined to the deliberate attempts to study experimentally the influence of light intensity on plants.

Plants grown in very low intensities of light, but of normal daily duration, resemble very closely etiolated plants given short daily exposures to light, with the important exception that they develop normal or even above normal chlorophyll concentration. However, the stems and roots resemble those of etiolated plants; in fact, when grown under extremely low light intensities, the etiolated effects may even be accentuated. The stem elongates very rapidly and, as a consequence, is high in moisture content and develops very little mechanical tissue. Root development is at a minimum. As the intensity of the light is increased by slow gradations, leaf development is greatly enhanced, the stems continue to elongate, and root development is kept at a minimum, but the plants begin to take on a healthy normal appearance.

The internal anatomy of the completely etiolated plant shows only slight differentiation of tissue and poorly developed organs. When the

plants are grown in extremely weak light, stem structure is similar to that of etiolated plants, but leaf structure is decidedly different. The leaves completely unfold and develop epidermal layers and show some differentiation among the inner cells. Ordinarily, in plants grown in weak light, the leaves are very thin and have only one layer of palisade cells and a more or less loosely organized parenchyma. When the light is increased in intensity up to moderate values, stem and leaf differentiation take place, and the plant has the general appearance of a normal plant. In moderate intensities the leaves reach their maximum size, and stem elongation, if dependent upon food elaborated by the leaves, is greatest. Moderate root development occurs. Under such conditions the leaves will have from one to two layers of palisade tissue and will develop the typical spongy parenchyma. Vegetative development reaches its highest point at moderate light intensities. At extremely low intensities nutrition limits the development of the leaves and height growth. At moderate intensities there is evidently sufficient food available for most vigorous vegetative growth. Flowering and fruit development does not occur in very weak light but at moderate intensities flowers are produced. The intensity for optimum development of flowers and fruit, as well as for maximum production of dry matter, is considerably higher than that required for best vegetative development.

At extremely high light intensities transpiration is excessive. Under such conditions the plants develop various devices which protect them against excessive heating and drying. This results in short stems, thicker leaves, but less total leaf area, increased water-conducting tissues, a more rapid rate of transpiration and, in general, features typical of xerophytic plants.

Root development is greatly enhanced by high light intensities. If plants abundantly supplied with nitrates could be grown in very high light intensities and at the same time in atmospheres containing a large supply of moisture, it is possible that vegetative growth would not be checked. However, there are other effects of high light intensity, aside from that resulting in a moisture deficit within the plant. Prolonged illumination of leaves at high intensities results first in an accumulation of starch and later in the entire disappearance of starch. High light intensities also tend to increase the alkalinity of the cell sap. In extreme cases this may interfere with the iron nutrition of the plant. In such cases the plants become chlorotic through the breakdown of chlorophyll.

These reactions of the plant to variations in light intensity are in general of an adaptive nature. At low intensities, the plant requires a very efficient photosynthetic apparatus. This is provided in large, thin leaves, high in chlorophyll concentration and widely spaced on the stem. At high light intensities the plant with large thin leaves is at a

disadvantage in meeting the excessive transpiration losses. In this case, the smaller, thicker, cutinized leaves are an advantage. Also a contraction in the volume occupied by the plant is advantageous.

REVIEW OF SPECIFIC INVESTIGATIONS

Beyond the juvenile stage the development of tissue in green plants under different light intensities depends upon the amount of carbohydrates produced. The development of dry weight is directly correlated with photosynthetic activity. The effect of light intensity upon photosynthesis is considered separately by Spoehr and Smith (Paper XXXI) and will not be taken up here.

Production of dry matter in plants is dependent on many other factors than light, hence experiments on the effect of light on the production of dry matter have failed to establish a definite proportionality.

In a series of experiments on the effects of light intensity on plant growth Lubimenko (62) grew plants in small cages which were provided with shades. Although temperature and humidity control were impossible, the variations in these factors, while important, were evidently not large enough to vitiate the results. His light values were given in terms of the amount which would pass through glass 5 mm. in thickness. Intensities varied from the amount of light which would pass through one layer of glass to the amount which would pass through 54 layers. The production of dry matter increased with light intensity up to a maximum and then decreased. He found that the optimum illumination for production of dry matter varied both with temperature and with chlorophyll concentration. The higher the chlorophyll concentration in the plant, the lower the light intensity required for maximum production of dry matter. Chlorophyll development was itself dependent upon light intensity. The optimum light intensity for chlorophyll development was considerably below that for the optimum production of dry matter. Strong light intensities tended to favor root growth more than shoot growth. Leaf areas attained a maximum at moderate light intensities and fell off with further increase or decrease in light. In 1905 Lubimenko (61), with the best methods then available, made a study of the effect of light intensity on chlorophyll concentration and was able to separate the shade-loving plants from the sun-plants on the basis of their ability to increase their chlorophyll concentration at low light intensities. Sun-plants showed approximately the same chlorophyll concentration at all light intensities, but shade-plants showed a considerable increase in chlorophyll concentration with decreasing light intensity.

Combes (22) grew a number of plants under an improved type of cloth shade, ingeniously designed so as to admit free air circulation and still exclude light. Temperature and humidity were maintained at values

close to those out of doors. The optimum light intensity for production of dry matter increased with the increasing age of the plant. Maximum dry weight of the fruit always occurred in full sunlight. The optimum intensities for growth are considerably above those given by Lubimenko.

Rosé (85), used the Combes frames, covered to supply intensities from 11 to 100 per cent, as measured by the Roscoe-Bunsen photometer. A decrease in light intensity stimulated leaf development at the expense of root development. He assumed that the optimum light intensity was that value at which maximum leaf area developed; however, maximum dry weight occurred at a light value considerably higher. Rosé tested the rate of photosynthesis of leaves developed under different light intensities. Garden peas showed maximum assimilation, per unit leaf weight, under full sunlight, whereas for *Teucrium* there seemed to be no appreciable increase in the rate of photosynthesis from plants grown and tested under 34 per cent light to those grown and tested in full sunlight. However, it should be noted that a gram of leaves, developed in full sunlight, has much less area than a gram developed in reduced light. He found that leaves developed at one-half to two-thirds of full sunlight could at certain stages of development assimilate carbon dioxide in full daylight faster than leaves developed in full daylight. But leaves developed in full daylight cannot assimilate in reduced light as fast as those developed in reduced light. Shade plants exhibited a greater range in morphological structure and in chlorophyll content of leaves when developed under varying conditions of light intensity than peas or other sun plants. With increasing light intensity a marked increase in the percentage of dry matter occurred. At 34 per cent light the dry matter was 18 per cent, at 100 per cent light the dry matter was 30 per cent. The root weight in percentage of total plant weight increased from 9 at 34 per cent light to 29 at 100 per cent light.

Growing various plants under shades in Louisiana, Shantz (93) found that potatoes, cotton, lettuce, and radishes increased in fresh weight as the light intensity was decreased from 100 to 50 per cent of full sunlight. None of the plants used was able to grow past the seedling stage in 6 per cent light.

Hasselbring (47), in Cuba, grew tobacco plants under light cheese cloth shades which transmitted approximately two-thirds of the light. The humidity was higher under the shades, evaporation considerably less, and the amount of water transpired was 30 per cent less. The leaf area was considerably greater under the shades, while fruit development was better in the open. From the standpoint of tobacco growers, shading was decidedly beneficial.

Growing soy beans under shade at Washington, D. C., Garner and Allard (37) found that the shading caused a decrease in the dry weight of

both the tops and the beans; likewise, the yield of seed was considerably reduced.

The effect on plants of shading to 44, 18, and 15 per cent of full sunlight in New Hampshire was studied by Gourley (41) and Gourley and Nightingale (42). Shaded leaves of the Carman peach tree averaged 69 per cent, and Elberta 59 per cent larger in area than unshaded leaves. Oldenburg apple-tree leaves from the shade were over three times as large as those developed outside the shade. Similar changes were observed in strawberry, asters, lettuce, buckwheat, geranium, and eggplant. The typical thin leaves with single layers of palisade cells and loosely organized parenchyma were produced in shade. The internodes were longer, but branches and spurs fewer, and root systems were restricted.

With seedlings of Douglas fir and Engelmann spruce grown in Utah at 7000 ft. elevation, under lath screens which provided $\frac{1}{4}$, $\frac{1}{2}$, and $\frac{3}{4}$ shade, Korstian (55) obtained best growth and survival with $\frac{1}{2}$ shade. The osmotic concentration of the sap as measured by freezing-point depression was 16.7 atmospheres under half shade as compared with 19.1 in full sunlight. The palisade tissue and spongy parenchyma were only weakly developed in the shade, and the needles were much thinner and less in cross-sectional area.

Apple trees shaded to about 5 per cent light intensity are described by Auchter *et al.* (6) to have larger and thinner leaves, long, spindly branches which tended to curl and twist at the ends, loose leaf structure, and early leaf fall. Where one-half of the tree was shaded and the other not, the shaded half developed like trees completely shaded, and the unshaded half developed like normal trees, except that during the second season the shaded half produced branches shorter than those on the completely shaded trees. He suggested that shading may be the primary cause of the poor development and dying of lower and inner branches of dense trees.

Coniferous seedlings under different intensities of artificial illumination increased in size with increasing light intensity (Bates, 7; Bates and Roeser, 8). The minimum amount of light necessary to maintain the seedlings for 11 months varied from about 1 to 6 per cent of total sunlight. In making his measurements, however, Bates compared the total radiation delivered by the lamp with the total radiation of the sun. Since only about 15 per cent of the radiation given by an electric lamp lies in the visible region, as contrasted with approximately 50 per cent for sunlight, these values are undoubtedly high.

Popp (75) grew soy beans with different degrees of shading. Initial stem elongation was greatest with decreasing light intensity, but the final height was greater in moderate light intensity. The best plants were produced under full sunlight. Leguminous plants which under full

sunlight have no tendency to twine, such as bush and lima beans, (117) and soy beans (75), may become twiners in reduced light intensity.

Zillich (122) grew plants in the open and under lattice shades which covered $\frac{1}{4}$, $\frac{1}{2}$, and $\frac{3}{4}$ of the area. The corresponding light intensities were 100, 75, 50, and 33 per cent, respectively. With temperature and humidity conditions remaining essentially uniform, most of his plants showed the usual morphological characteristics developed in the shade, though weeds were less affected than cultivated plants. In some plants flowering was delayed by shading, as was also the ripening of the fruit. Fresh weight and the number of seeds per plant were often at a maximum at one-fourth to one-half shade for weeds, but the size of seeds was largest with three-fourths shade. Cultivated plants, peas, and barley showed a decrease in yield of seeds and also in dry weight, with decrease in light intensity.

Shirley (94) grew a number of plants under different light intensities using both artificial light and sunlight. Dry weight increased with increasing light intensities from 30 to 700 foot-candles, an increase more or less in direct proportionality to intensity. The plants grown under artificial light were in the path of an atmosphere delivered from an air-conditioning machine which rendered temperature and humidity constant. Plants grown in the greenhouse under different shades generally attained a maximum dry weight at the highest light intensity available. Temperature and moisture conditions were, in general, favorable for growth in the greenhouse. When the plants were grown in shades out-of-doors where temperature conditions are not always favorable, the dry weight did not always show an increase with increased light. For several plants there appeared to be an optimum value below that of full sunlight. Later in the season, however, the same species showed greatest dry weight in full sunlight. The percentage of dry matter always increased with increasing light intensity, as also the ratio of the roots to the tops. Height growth decreased with increasing light when the light values were high, but at lower intensities height growth increased with light. Leaf structure tended to become more compact with increasing light. Plants grown under from 1 to 20 per cent light developed only one layer of palisade tissue, whereas those grown at 70 per cent had two distinct layers. The cells increased in size from low light intensities up to a certain optimum, at which maximum leaf area was developed, and thereafter there was a decrease in size.

Hoffman (49) compared plants grown in Vienna in a shaded court with those on a roof garden. The light intensity in the court was only about one-sixth of that on the roof garden. She made a careful study of leaf area and leaf anatomy of the plants used. Leaf areas and width of the epidermal cells were greater in the shade while leaf thickness, length of epidermal cells, and the cross section of vascular bundles were greater

in full sunlight. There appeared to be little difference in the number of stomata per square millimeter, but there was a tendency for greater concentration of stomata in the plants grown in the open. There were more rows of palisade cells, and the cells were longer in the sun-plants. The epidermis was thicker and there were more cells in the spongy parenchyma. The vascular bundles developed 26 per cent more cells in the light, and the cell walls of the epidermis were much thicker in the light.

Penfound (72; 73) grew *Helianthus annuus*, *Polygonum hydropiper*, and castor beans in full sunlight and under lath shades which transmitted about 20 per cent light. Root length and thickness, stem thickness, and leaf thickness were favored by full sunlight, while stem length was greater in the shade. The depth of xylem in roots, hypocotyls, and stems was greater in the light, and the cell walls of wood and bast fibers were thicker. In full sunlight the leaf epidermal cells were larger, the palisade and parenchyma layers deeper, and the number of stomata greater. The conducting vessels per unit leaf area were also larger in full sunlight but the rate of flow of water was the same.

Steinbauer (101) cultivated for 10 weeks seedlings of *Fraxinus pennsylvanica* in mineral nutrient solutions equivalent in osmotic concentration to atmospheric pressures of 0.01, 0.1, and 1.0, respectively, and subjected to light intensities of 130, 70, 48, and 31 footcandles. The plants which received only 31 foot-candles illumination succumbed at the end of 2 weeks in all solution concentrations. Gain in dry weight and in length of tops and roots was greater in the highest light intensity. Best growth for these light intensities occurred in the solution with a concentration equivalent to 0.1 atmosphere and poorest growth with the equivalent of 0.01 atmosphere.

Lubimenko (62), Burns (17), Grasovsky (43), and other investigators have studied the light intensity required for a carbon dioxide balance—that is, when the carbon dioxide given off in respiration will just be used up in the photosynthetic process. They have found this to be attained at rather low light intensities, about 1 to 5 per cent of full sunlight.

The actual intensity required for a carbon dioxide balance depends upon the previous treatment to which the plants have been subjected, plants grown in strong light requiring a higher intensity for a balance. Burns has considered this point at which the carbon dioxide balance occurs as representing the minimum light requirements of the species in question. Such an interpretation must, of course, take into consideration plants growing under natural conditions, since they must build up in light a reserve to carry them through the night. Furthermore, the respiration rate increases, and probably also the point of balance, with increasing temperature. This minimum requirement also assumes that light is required only for the photosynthetic process.

The effects of light intensity on the structure of plants has received a great deal of study. The differences between shade leaves and sun leaves has been pointed out by many investigators. This work is reviewed in the general textbooks of botany and plant physiology and especially by Goebel (40), Lundegårdh (64), MacDougal (66), and Haberlandt (44). In practically all this work no quantitative studies have been made. Studies of the structure of plants grown under known light conditions have been made by Hasselbring (47), Popp (75), Pfeiffer (74), Hoffmann (49), and Shirley (94). Practically all these investigators, however, have used the sun as a source of radiation. The features observed by these workers are those described in the introduction and text of this section.

LIGHT INTENSITY AND MINERAL NUTRITION

Stutzer and Goy (103) made analyses of the nitrogen, ash, and nicotine content of tobacco grown under shades transmitting about 70 and about 6 per cent light. Yield of leaves was higher in the 70 per cent light. Total nitrogen, ash, and potassium increased with decreasing light, while nicotine decreased.

Studying the chemical composition of blue-stem wheat which had ripened under the shade of 16-ounce duck and comparing the analyses with those of plants ripened in full sunlight, Thatcher and Watkins (107) found the shaded kernels higher in protein and lower in starch. The ash and moisture content of the kernels seemed not to be affected. Further studies by Thatcher (106) of wheat, oats, barley, field peas, and emmer gave similar results. In this case the plants were subjected to shading for a longer period. Shading increased the percentage of mineral and nitrogenous matter, but decreased the percentage of dry matter and stored carbohydrates.

Kraybill (56) found that shading apple trees caused an increase in the percentage of total nitrogen, a decrease in carbohydrates, and an increase in dry matter. This is opposite to the findings of other workers on herbaceous plants but agrees with some of the writer's unpublished results on shaded conifers. Vinson (117) found a higher ratio of nitrogen to carbohydrates in shaded plants. Auchter *et al.* (6) found that shading apple trees to 5 per cent of normal sunlight caused a lower starch content of terminals and spurs, evidently a result of reduced photosynthesis. The shaded trees and shaded halves of trees were lower in percentages of dry matter and generally lower in carbohydrates but higher in nitrogen.

Surveying the influence of light intensity and light quality upon the assimilation of nitrates in wheat, Tottingham and Lowsma (109) determined that those plants exposed to only 1½ hr. of direct sunlight on clear days, as contrasted with plants kept in the greenhouse, had more protein

and absorbed more nitrogen. Wiesmann (119) found that plants grown in full sunlight absorbed more mineral nutrients than those grown in lower light intensities.

Cooper (23) found a correlation between the tolerance of plants to shade and to strong ions. Plants which make best growth on fertile soils and require strong ions were intolerant of shade and had a high carbohydrate reserve, whereas plants which grow on poor soils and endure large quantities of weak ions were more tolerant of shade but had a lower carbohydrate reserve.

Tyson (116) made chemical analyses of sugar beets grown in the open and under 1, 2, 3, and 4 layers of cheesecloth, and under 2 layers of cheesecloth plus 1 layer of black calico. Ash content of roots and leaves, based on percentage of dry weight, increased somewhat with decreasing light. This was reflected in increased magnesium, phosphorus, and calcium. The sugar percentage of the beets on a dry-weight basis was about the same for all light intensities. Total yield of beets and tops increased directly with increasing light intensity. Catalase activity was favored by increasing light intensity and oxidase activity by decreasing light intensity.

The effect of light intensities on the rate of reproduction of *Lemna major* was studied by Clark (21). The plants were grown in nutrient solution and subjected to illuminations of 400 and 900 foot-candles. The rate of reproduction, which is a measure of photosynthetic activity, increased in both cases with increased length of day up to continuous illumination. The plants with 900 foot-candles reproduced more rapidly than those with 400 foot-candles, regardless of the length of day, and the difference between the two treatments became greater as the daily period of illumination was increased. With continuous illumination the plants tended to become chlorotic. Changing the solutions every 12 hr. avoided this difficulty, the iron in the solution being no longer available after a period of continuous illumination.

Loehwing (60), studying the influence of light on the hydrogen ion concentration of the cell sap of wheat, found that plants grown on alkaline soil at high light intensities became chlorotic. Under such conditions the iron did not move from the roots up the stems. Full sunlight caused a decrease in the acidity of the cell sap. In the alkaline cell sap, iron was insoluble and hence could not be transported. Shaded plants were able to remain green under the same soil conditions.

The work of these investigators, together with observations of other workers who grew plants in nutrient solutions, indicates that under certain conditions in which the soil or nutrient solution is near the neutral point, or slightly alkaline, strong light intensity may interfere with the iron nutrition of the plants. This question undoubtedly merits further investigation and should prove a fruitful field for further study.

THE INFLUENCE OF LIGHT INTENSITY ON FLOWERING

Under extremely low light intensities, plants may develop leaves but they do not flower. The minimum values required for flowering have not been accurately established. Apparently at least 10 per cent of normal summer sunlight of temperate regions is required for the flowering of most plants. The plants which commonly grow in the shade are able to flower at lower intensities than those normally accustomed to full sunlight. Ordinarily, shading does not appreciably delay the time of flowering, unless it is so dense as to seriously interfere with the nutrition of the plant. Shading often tends to prolong the vegetative and fruiting period, while full sunlight tends to hasten maturity.

Gourley (41) found that flowering of apple trees shaded in the spring before the buds opened was not appreciably interfered with by the shade, but the next season, after a full year of shade, it was considerably reduced, while the third season two trees produced only eight clusters. Reduction in flowering was likewise observed for tomato, geranium, and nasturtium. Similar reduction in flowers and delay in flowering were noted by Auchter *et al.* (5, 6).

Daniel (26) found that shading head lettuce not only prevented the formation of the typical head but also caused a decrease in flower heads from 3287 to 425 and in number of fertile achenes per head from 24 to 13. Similar reduction in number of flowers and fruit in shaded plants have been observed by Zillich (122), Shantz (93), Shirley (94), and Vinson (117), as well as by many ecological workers. Schrader and Marth (90) found that shading individual apple fruits caused an inhibition of red-pigment development and also some reduction in size of fruit.

THE INFLUENCE OF LIGHT INTENSITY UPON TRANSPIRATION, WINTER HARDINESS, AND RESISTANCE TO DROUGHT

Conducting a very comprehensive series of experiments on the transpiration of crop plants, Briggs and Shantz (15) made daily records of radiation, temperature, wet-bulb depression, and wind velocity. These were correlated with the daily rate of transpiration over a period of two years for a wide variety of grains and leguminous plants. The correlation ratio between radiation and transpiration varied from 0.65 for small grains to 0.48 for leguminous crops. Individual varieties showed ratios as high as 0.80. They showed that of the radiation received, an equivalent of 50 to 100 per cent was dissipated in transpiration. Likewise, Penfound (72) observed that *Helianthus annuus* plants developed in full sunlight, evaporated 3610 cc., as contrasted with 821 cc. evaporated by the same species in a shade providing 20 per cent of full sunlight. For *Polygonum hydropiper* the values were 3125 and 1190 for sun and

shade, respectively. This increased evaporation occurred in spite of the fact that the leaf surface in each case was greater in the shade. Similar responses were found to hold for the castor bean (73). Maximow and Lebedincev (68) found that light stimulated the development of water-conducting vessels.

Lachenmeier (57) tested water intake and transpiration of *Veronica Beccabunga*, *Hieracium pilosella*, and *Myosotis palustris* under constant conditions of temperature, humidity, and light. With light of 8 lux, transpiration was but little higher than in darkness; with 100 lux somewhat higher; while with 30,000 lux a decided increase occurred. *Veronica* more than doubled the rate in darkness. Furthermore, with continuous illumination the transpiration rate increased up to a maximum at the end of 1 hour and remained constant thereafter. For *Hieracium* at 30,000 lux the transpiration rate immediately increased threefold but later fell off to about 2 to $2\frac{1}{2}$ times the rate in darkness. Other plants, including excised shoots, showed similar correlation between light intensity and transpiration.

Chodat and Kamm (20) noticed that the rate of transpiration of alpine plants decreased at high light intensities. Chodat (19) attributes this decrease to a change in cellular permeability under the influence of the high content of blue and ultra-violet light at high altitudes. Since this explanation is at variance with the results of Priestley and Lepeschkin, who found that light increased the permeability of protoplasm, it should not be accepted without direct experimental proof. Possibly some other factor is responsible, such as the closing of stomata, due to a deficit in water supply. Mittmeyer (69) showed that the daily cuticular transpiration of xerophytes followed light intensity more closely than evaporation. In xerophytes cuticular transpiration accounts for two-thirds to three-fourths of the total, and in mesophytes one-half or more.

A careful study of the effect of radiation on transpiration was recently conducted by Arthur and Stewart (1). Temperature, humidity, and light conditions were carefully maintained. The loss of water in 12 hr. per square inch of leaf surface at 73° to 78°F. and 50 per cent relative humidity was: in darkness, 0.05 to 0.07 gm.; at a radiation intensity of 0.28 gm. cal./cm.²/min., 0.60 to 0.63 gm.; at 0.65 gm. cal./cm.²/min., 1.00 to 1.29 gm. At 88 per cent relative humidity the transpiration was: in darkness, 0.03 to 0.05 gm.; at 0.28 gm. cal./cm.²/min., 0.56 gm.; at 0.65 gm. cal./cm.²/min., 0.93 to 1.17 gm. Increasing the temperature to 98° to 100°F. caused a loss at 0.65 gm. cal./cm.²/min. of 2.67–2.82 gm. at 68 per cent relative humidity. There was, therefore, a very definite dependence of transpiration upon radiation intensity.

Sunlight may at times be so high as to cause injury to plants, particularly young seedlings. This is generally due to excessive heat or to excessive transpiration. Such injuries have been reported in coniferous

nurseries by Hartley (45), Hartley and Merrill (46), Toumey and Neethling (112), and Li (59). It is possible that such injuries may occur in much larger trees. Sun scald of fruit trees is commonly reported. This is due to excessive heating rather than to too much light. Much so-called winter injury, especially in evergreens, frequently attributed to freezing temperatures, is probably due to the excessive transpiration caused by a warm bright day at a time when the ground is frozen, rather than to low temperature.

Dexter (27, 28) has shown that light has a profound influence on hardening of plants against cold. Plants deprived of carbon dioxide would not harden under any circumstances. With cold days and warm nights, or continuous cold in darkness, hardening did not occur to any appreciable extent; continuous cold in light, or cold nights and warm days both induced hardening. Any treatment involving low temperatures which tended to favor photosynthesis and retard respiration and growth assisted hardening. Tysdal (115) found that alfalfa plants harden better if kept for 16 hr. at 0°C. in the dark, and 8 hr. at 20°C. in the light, than if given a shorter day in light. That shading decreases hardiness has been observed by Auechter and Schrader (5) and several others. Unpublished work of the writer indicates that plants developed in shade are less resistant to drought than those grown in full sunlight.

MINIMUM LIGHT REQUIREMENTS

It is beyond the scope of this paper to present a detailed review of ecological studies of the effect of light intensity on plants. A few words may be said, however, about minimum light requirements.

There is a vast literature dealing with the determination of minimum light requirements of plants as ascertained by ecological methods; *i.e.*, by finding the lowest light intensity under which a given species of plant can exist. Of this work, the investigations of Wiesner (120) are the most extensive. They cover a period of 30 years and include plants of both hemispheres, from tropical to arctic conditions. This work cannot be taken up in detail here, but it is well to point out that the methods used by him and many other investigators are accurate enough to show only general trends. For instance, Wiesner points out that plants in warm regions require less light than the same species growing farther north or at higher altitudes. This, however, is a response to temperature rather than light. Also workers have come to the conclusion that the light requirements of a plant increase with increasing age, and with decreasing soil fertility and soil moisture. Such conclusions must be put to laboratory test and critical analysis before they can be accepted. Furthermore, the ability of a given plant species to become established in natural shady habitats is often determined by conditions favorable for seed germination and other factors quite independent of light. For further discussion of

this subject the reader is referred to Zon and Graves (123) and to Rübél (86). The importance of factors other than light in determining the establishment and growth of vegetation under natural canopies is stressed by Fricke (35), Toumey (110), Toumey and Kienholz (111), and Fabricius (32, 33). Furthermore, the ecologist and forester are in reality much less concerned about the minimum amount of light required to keep a plant alive than the amount required for satisfactory growth, since the plant which is living under light conditions sufficient only to maintain life may soon succumb to other unfavorable conditions.

A correlation between light intensity and the occurrence and growth of various species of plants can be established. Recent studies of this type have been conducted by Gast (38), Atkins and Poole (3), Atkins and Stanbury (4), Atkins (2), Holeh (50), and Shirley (96). In practically all cases maximum growth is attained in full sunlight. Similar studies have shown correlation between light intensity and the distribution and growth of water plants (70, 87, 14).

SUMMARY

Solar radiation is highly variable in intensity and quality, but no artificial source of radiation gives light comparable in intensity and quality with midday sunlight in summer. In studies of the effects of radiation on plants it is important to have as careful control and measure of the other factors affecting plant growth as it is possible to obtain.

Since green plants are dependent upon light for the synthesis of their food supply, any attempt to cultivate them without light, or in light of too low intensity for maximum photosynthesis, upsets their nutritional economy. In order to have a true understanding of the influence of light and lack of light on plants, it is necessary to distinguish between those effects due to starvation and other effects caused by radiation.

Plants grown without light have attenuated stems, small leaves only partially unfolded, no green pigment, and only weakly differentiated tissue. They give the impression of plants whose development has been arrested. Etiolated stems, particularly the apical regions, are rich in nitrogenous compounds and relatively poor in carbohydrates, even when ample carbohydrates may still be available in the seed or root. The effect of light on etiolated plants depends upon the quantity of light received, and is local in its action. The true nature of etiolation is not fully understood but it is probable that the nutritional disturbance, caused by the impermeability in darkness of the protein and fatty substances comprising the protoplasm of meristematic tissue, plays a dominant role in this phenomenon.

Light has a very pronounced effect upon the rate of elongation of shoots of juvenile plants. When etiolated plants are exposed to light,

there is, during the first few minutes, a pronounced increase in growth rate followed by a decrease below the initial rate. Continuous light causes a depression in growth rate which later on tends to return to normal. It shortens the period of elongation and causes a reduction in total length. Exposure to darkness after continuous illumination causes at first an increase in growth, followed by a return to the initial rate. Brief exposures to light induce a wave-formed response in the growth curve, the period of which depends upon the amount of light to which the plant is exposed.

In low intensities of normal daily duration, plants develop chlorophyll and the leaves unfold, but otherwise they present the appearance of etiolated plants, *viz.*, long internodes, weak, succulent stems, vegetative growth only, poor root development, and thin leaves with loosely organized, thin-walled cells. As the intensity is increased, vegetative growth increases to a maximum at about 25 to 50 per cent of normal summer sunlight of temperate regions. The plants attain maximum height and leaf area. The leaves are still comparatively thin and flowering is considerably reduced. Such plants contain a higher percentage of nitrogenous compounds, particularly in the soluble forms, than plants developed under full sunlight. A further increase in light intensity causes an increase in dry matter but a decrease in height and leaf area. Maximum fruitfulness and maximum mechanical and water-conducting tissue usually occur at about the same light intensity as maximum dry weight. Still further increases upset the water economy and often the iron nutrition of the plant and result in local injuries to leaves or even in some cases death through excessive heating.

Transpiration, the osmotic concentration of plant sap, and alkalinity of sap increase directly with light intensity. The ash content per plant—but not always per unit dry weight—increases with increasing light intensity, as does also the ability of the plant to use strong ions.

Light favors the hardening of plants against cold, provided it is accompanied by proper temperature conditions, *viz.*, warm days and cold nights. Light also favors the development of drought resistance in plants. Both of these effects depend to a considerable extent upon the accumulation of a carbohydrate reserve.

In natural habitats many factors aside from light affect the rate of photosynthesis and the growth of plants. Frequently plants, especially in desert regions, may perform their entire daily photosynthesis in a few morning hours. Therefore it is difficult to study the minimum light requirements of plants in natural habitats. Furthermore, it must be borne in mind that a plant, to maintain itself successfully in a given habitat, must have sufficient light not only to enable it to exist, but sufficient for active growth and for the accumulation of a food reserve for withstanding unfavorable seasons and for reproduction.

REFERENCES

1. ARTHUR, J. M., and W. D. STEWART. Transpiration of tobacco plants in relation to radiant energy in the visible and infra-red. *Contr. Boyce Thompson Inst.* **5**: 483-501. 1933.
2. ATKINS, W. R. G. The measurement of daylight in relation to plant growth. *Empire For. Jour.* **11**: 42-52. 1932.
3. ATKINS, W. R. G., and H. H. POOLE. Photo-electric measurements of illumination in relation to plant distribution. II. *Sci. Proc. Roy. Dublin Soc.* **19**: 295-309. 1929.
4. ATKINS, W. R. G., and F. A. STANBURY. Photo-electric measurements of illumination in relation to plant distribution. III. *Sci. Proc. Roy. Dublin Soc.* **19**: 517-531. 1930.
5. AUCHTER, E. C., and A. L. SCHRADER. Influence of shade on the behavior of apple trees. *Proc. Intern. Cong. Plant Sci. [Ithaca]* **2**: 1056-1069. 1926.
6. AUCHTER, E. C., A. LEE SCHRADER, F. S. LAGASSE, and W. W. ALDRICH. The effect of shade on growth, fruit bud formation and chemical composition of apple trees. *Proc. Amer. Soc. Hort. Sci.* **23**: 368-382. 1926.
7. BATES, C. G. The relative light requirements of some coniferous seedlings. *Jour. For.* **23**: 869-879. 1925.
8. BATES, C. G., and JACOB ROESER, JR. Light intensities required for growth of coniferous seedlings. *Amer. Jour. Bot.* **15**: 184-195. 1928.
9. BENECKE, W., and L. JOST. *Pflanzenphysiologie. 4te umgearb. Aufl.* 2 Vols. Jena, 1924.
10. BERTRAND, G., and M. ROSENBLATT. Sur la teneur inégale en manganèse des feuilles vertes et des feuilles étiolées. *Compt. Rend. Acad. Sci. [Paris]* **194**: 1405-1408. 1932.
11. BLAAUW, A. H. Licht und Wachstum I. *Zeitsch. Bot.* **6**: 641-703. 1914.
12. BLAAUW, A. H. Licht und Wachstum II. *Zeitsch. Bot.* **7**: 465-532. 1915.
13. BLAAUW, A. H. Licht und Wachstum III. *Mededeel. Landbouwhoogeschool. Wageningen* **15**, 1918.
14. BOURN, W. S. Ecological and physiological studies on certain aquatic angiosperms. *Contr. Boyce Thompson Inst.* **4**: 425-496. 1932. (102 references.)
15. BRIGGS, L. J., and H. L. SHANTZ. Daily transpiration during the normal growth period and its correlation with the weather. *Jour. Agric. Res.* **7**: 155-212. 1916.
16. BROWN, J. G. Subcortical formation and abnormal developments of stomata in etiolated shoots of *Opuntia Blakeana*. *Botan. Gaz.* **70**: 295-307. 1920.
17. BURNS, G. P. Minimum light requirements referred to a definite standard. *Vermont Agric. Exp. Sta. Bull.* **235**. 1923.
18. CANNON, W. A. Absorption of oxygen by roots when the shoot is in darkness or in light. *Plant Physiol.* **7**: 673-684. 1932.
19. CHODAT, FERNAND. Influence de la lumière sur la transpiration végétal. *Compt. Rend. Soc. Phys. et Hist. Nat. Genève.* **48**: 55-58. 1931.
20. CHODAT, F., and S. KANN. *Compt. Rend. Soc. Phys. et Hist. Nat. Genève.* **48**: 50-55. 1931.
21. CLARK, N. A. Rate of reproduction of *Lemna major* as a function of intensity and duration of light. *Jour. Phys. Chem.* **29**: 935-941. 1925.
22. COMBES, R. Détermination des intensités lumineuses optima. *Annales Sci. Nat. Bot. IX.* **11**: 75. 1910.
23. COOPER, H. P. Ash constituents of pasture grasses, their standard electrode potentials and ecological significance. *Plant Physiol.* **2**: 193-214. 1930. (70 references.)

24. COUPIN, H. Sur les causes de l'élongation de la tige de plantes étiolées. *Compt. Rend. Acad. Sci. [Paris]* **170**: 189-191. 1920.
25. COUPIN, H. Sur une tige à géotropisme horizontal. *Compt. Rend. Acad. Sci. [Paris]* **172**: 608-610. 1921.
26. DANIEL, LUCIEN. Recherches sur le développement comparé de la laitue au soleil et à l'ombre. *Compt. Rend. Acad. Sci. [Paris]* **168**: 694-697. 1919.
27. DEXTER, S. T. Decreasing hardiness of winter wheat in relation to photosynthesis, defoliation and winter injury. *Plant Physiol.* **8**: 297-304. 1933.
28. DEXTER, S. T. Effect of several environmental factors on the hardening of plants. *Plant Physiol.* **8**: 123-139. 1933.
29. DILLEWIJN, C. VAN. Die Lichtwachstumsreaktionen von Avena. *Rec. Trav. Botan. Neerl.* **24**: 307-581. 1927. (Extensive bibliography.)
30. EISENMENGER, WALTER S. The distribution of nitrogen in tobacco when the supplies of nitrogen and of light are varied during the growing period. *Jour. Agric. Res.* **46**: 255-265. 1933. (32 references.)
31. ERMAN, CARL. Ueber die Variation der Lichtwachstumsreaktion bei verschiedenen Rassen von Avena sativa. *Botan. Notiser* 201-213. 1930.
32. FABRICIUS, L. Der Einfluss des Wurzelwettbewerbs des Schirmstandes auf die Entwicklung des Jungwuchses. *Forstw. Centralbl.* **49**: 329-345. 1927.
33. FABRICIUS, L. Neue Versuche zur Feststellung des Einflusses von Wurzelwettbewerb und Lichtenzug des Schirmstandes auf den Jungwuchs. *Forstw. Centralbl.* **51**: 477-506. 1929.
34. FIGDOR, W. Ueber den Einfluss des Lichtes auf die Gestaltung der Bowicia volubilis sowie über die Vermehrung und den Bau ihrer Zwiebel. *Sitzungsab. Akad. Wiss. Wien. Math.-Naturw. Kl. Abt. 1.* **137**: 45-54. 1928.
35. FRICKE, KARL. "Licht- und Schattenholzarten" ein wissenschaftlich nicht begründetestes Dogma. *Forstw. Centralbl.* **30**: 315-325. 1904.
36. FRIEDEL, JEAN. De l'action exercée sur la végétation par une obscurité plus complète que l'obscurité courante des laboratoires. *Compt. Rend. Acad. Sci. [Paris]* **153**: 825-826. 1911.
37. GARNER, W. W., and H. A. ALLARD. Effect of the relative length of day and night and other factors of the environment on growth and reproduction in plants. *Jour. Agric. Res.* **18**: 553-606. 1920.
38. GAST, P. R. A thermoelectric radiometer for silvical research. *Harvard Forest Bull.* 14. 1930.
39. GOEBEL, K. Organography of plants especially of Archegoniatae and Spermatophyta. 2 v. Oxford, 1900-1905.
40. GOEBEL, K. Organographie der Pflanzen. Samenpflanzen. Fischer; Jena, 1932.
41. GOURLEY, J. H. The effects of shading some horticultural plants. *Amer. Soc. Hort. Sci.* **17**: 256-260. 1920.
42. GOURLEY, J. H., and G. T. NIGHTINGALE. The effects of shading some horticultural plants. *New Hampshire Agric. Exp. Sta. Tech. Bull.* 18. 1-22. 1921.
43. GRASOVSKY, A. Some aspects of light in the forest. *Bull. Yale Univ. Sch. For.* **23**. 1929.
44. HAERLANDT, G. Physiological plant anatomy. London, 1914.
45. HARTLEY, CARL. Stem lesions caused by excessive heat. *Jour. Agric. Res.* **14**: 595-604. 1918.
46. HARTLEY, CARL, T. C. MERRILL, and ARTHUR S. RHOADS. Seedling diseases of conifers. *Jour. Agric. Res.* **15**: 521-558. 1918.
47. HASSELBRING, H. Effect of shading on the transpiration of the tobacco plant. *Botan. Gaz.* **57**: 257-286. 1914.
48. HIBBARD, R. P. Report of the work in plant physiology. *Mich. State Board of Agric.* 332-335. 1927.

49. HOFFMANN, ELISE. Der Ausdruck optimalen Lichtgenusses im Blattbau der Pflanze. *Botan. Arch.* **18**: 288-295. 1927.
50. HOLCH, A. E. Development of roots and shoots of certain deciduous seedlings in different forest sites. *Ecology* **12**: 259-298. 1931.
51. JEFFS, R. E. The elongation of root hairs as affected by light and temperature. *Amer. Jour. Bot.* **12**: 577-606. 1925.
52. JODIDI, S. L. Nitrogen metabolism in etiolated corn seedlings. *Jour. Agric. Res.* **31**: 1149-1164. 1925.
53. JODIDI, S. L. Isolation and identification of some organic nitrogenous compounds occurring in etiolated corn seedlings. *Jour. Agric. Res.* **34**: 649-656. 1927.
54. KONINGSBERGER, V. J. Lichtintensität and Lichtempfindlichkeit. *Rec. Trav. Botan. Neerland.* **20**: 257-312. 1923.
55. KORSTIAN, C. F. Some ecological effects of shading coniferous nursery stock. *Ecology* **6**: 48-51. 1925.
56. KRAYBILL, H. R. Effects of shading some horticultural plants. *Amer. Soc. Hort. Sci.* **19**: 9-17. 1922.
57. LACHENMEIER, JOSEF. Transpiration und Wasserabsorption intakter Pflanzen nach vorausgegangener Verdunkelung bei Konstanz der Lichtintensität und der übrigen Aussenfaktoren. *Jahrb. Wiss. Bot.* **76**: 765-827. 1932.
58. LEPESCHKIN, W. W. Light and the permeability of protoplasm. *Amer. Jour. Bot.* **17**: 953-970. 1930.
59. LI, TSI-TUNG. The effect of intense sunlight on tree seedlings. *Lingnan Sci. Jour.* **6**: 315-321. 1928.
60. LOEWING, W. F. The effect of light intensity on tissue fluids in wheat. *Proc. Iowa Acad. Sci.* **37** (1930): 107-110. 1931.
61. LUBIMENKO, W. Sur la sensibilité de l'appareil chlorophyllien des plantes ombrophiles et ombrophobes. *Rev. Gén. Bot.* **17**: 381-415. 1905.
62. LUBIMENKO, W. Production de la substance sèche et de la chlorophylle chez les végétaux supérieurs aux différentes intensités lumineuses. *Annales Sci. Nat. Bot. IX*, **7**: 321-415. 1908.
63. LUBIMENKO, V., and R. KARISNEV. Influence de la lumière sur l'assimilation des réserves organique de graines par les plantules I. *Compt. Rend. Acad. Sci. USSR* 1927: 381-386.
64. LUNDEGÅRDH, H. Environment and plant development (transl. and ed. by E. Ashby). London, 1931.
65. MACDOUGAL, D. T. The influence of light and darkness upon growth and development. *Mem. New York Bot. Gar.* **2**: 319 pp. 1903. (Extensive bibliography to 1900.)
66. MACDOUGAL, D. T. The green leaf; the major activities of plants in sunlight. Appleton-Century Co. New York, 1930.
67. MASON, C. The inhibitive effect of direct sunlight on the growth of the date palm. *Jour. Agric. Res.* **31**: 455-468. 1925.
68. MAXIMOW, N. A., and E. LEBENDINCEV. Influence of light relations on the development of root systems. *Ber.-Deut. Bot. Ges.* **41**: 292-297. 1923.
69. MITTMEYER, GERDA. Studien über die Abhängigkeit der Transpiration verschiedener Blatttypen von Licht und Sättigungsdefizit der Luft. *Jahrb. Wiss. Bot.* **74**: 364-428. 1931. (*Biol. Abs.* **6**: 2523. 1932.)
70. MONTFORT, C. Studien zur vergleichenden Ökologie der Assimilation. *Jahrb. Wiss. Bot.* **71**: 52-105; 106-148. 1929.
71. NIGHTINGALE, G. T., and L. G. SCHERMERHORN. Nitrate utilization by asparagus in the absence of light. *Science* **64**: 282. 1926.
72. PENFOUND, W. T. Plant anatomy as conditioned by light intensity and soil moisture. *Amer. Jour. Bot.* **18**: 558-572. 1931.

73. PENFOUND, W. T. The anatomy of the castor bean as conditioned by light intensity and soil moisture. *Amer. Jour. Bot.* **6**: 538-546. 1932.
74. PFEIFFER, NORMA E. Anatomical study of plants grown under glasses transmitting light of various ranges of wave length. *Botan. Gaz.* **85**: 427-436. 1928.
75. POPP, H. W. Effects of light intensity upon soy beans. *Botan. Gaz.* **82**: 306. 1926.
76. PRIESTLEY, J. H. The effect of brief light exposures upon etiolated plants. *New Phytol.* **24**: 271-283. 1925.
77. PRIESTLEY, J. H. On the anatomy of etiolated plants. *New Phytol.* **25**: 145-170. 1926.
78. PRIESTLEY, J. H., and J. EWING. Physiological studies in plant anatomy. *New Phytol.* **22**: 30-44. 1923.
79. PROBST, SIEGMUND. Über den Einfluss einer Sprossbelichtung auf das Wurzelwachstum und derjenigen einer Wurzelbelichtung auf das Sprosswachstum. *Planta, Arch. Wiss. Bot.* **4**: 651-709. 1927.
80. REID, MARY E. Growth of tomato cuttings in relation to stored carbohydrate and nitrogenous compounds. *Amer. Jour. Bot.* **13**: 548-574. 1926.
81. REID, MARY E. Growth of seedlings in light and in darkness in relation to available nitrogen and carbon. *Botan. Gaz.* **87**: 81-118. 1929.
82. REID, MARY E. Relation of composition of seed and the effects of light to growth of seedlings. *Amer. Jour. Bot.* **16**: 747-769. 1929.
83. ROBBINS, W. J. Cultivation of excised root tips and stem tips under sterile conditions. *Botan. Gaz.* **73**: 376-390. 1922.
84. ROBBINS, W. J., and W. E. MANEVAL. Effect of light on growth of excised root tips under sterile conditions. *Botan. Gaz.* **78**: 424-432. 1924.
85. ROSÉ, E. Énergie assimilatrice chez les plantes cultivées sous différents éclaircements. *Annales Sci. Nat. Bot.* **IX**. **17**: 1-110. 1913.
86. RÜBEL, EDWARD. Lichtklima und Lichtgenuss. *Abderhalden Handbuch Biol. Arbeitsmethoden. Abt. XI.* **5**: 233-292. (Lieferung 279.) 1928. (Extensive bibliography.)
87. RUTTNER, F. Über den Gaswechsel von Elodiasprossen verschiedenen Tiefenstandorte unter den Lichtbedingungen grösserer Seetiefen. *Planta, Arch. Wiss. Bot.* **2**: 588-599. 1926.
88. SACHS, JULIUS VON. *Physiology of plants.* (Trans. H. Marshall Ward) Oxford, 1897.
89. SCHÖNFELD, ERICH. Der Einfluss von Licht auf etiolierten Laubblättern. *Beitr. Biol. Pflanz.* **12**: 351-412. 1914. (Extensive bibliography.)
90. SCHRADER, A. L., and P. C. MARTH. Light intensity as a factor in the development of apple color and size. *Proc. Amer. Soc. Hort. Sci.* **28**: 552-555. 1931.
91. SCHULZE, E. Ueber einige stickstoffhaltige Bestandteile der Keimlinge von *Soja hispida*. *Hoppe-Seyler's Zeitsch. Physiol. Chem.* **12**: 405-415. 1888.
92. SCHULZ, E. R., and NOEL F. THOMPSON. Chemical composition of etiolated and green *Berberis* sprouts and their respective roots. *Botan. Gaz.* **81**: 312-322. 1926.
93. SHANTZ, H. L. Effects of artificial shading on plant growth in Louisiana. U.S. Dept. Agric., Bur. Pl. Ind. Bull. 279. 1913.
94. SHURLEY, HARDY L. Influence of light intensity and light quality upon the growth of plants. *Amer. Jour. Bot.* **16**: 354-390. 1929.
95. SHURLEY, HARDY L. The influence of light and temperature upon the utilization by young seedlings of organic reserves in the seed. *Amer. Jour. Bot.* **18**: 717-727. 1931.
96. SHURLEY, HARDY L. Light intensity in relation to plant growth in a virgin Norway pine forest. *Jour. Agric. Res.* **44**: 227-244. 1932.

97. SIERP, HERMAN. Ein Beitrag zur Kenntnis des Einflusses des Lichtes auf das Wachstum der Koleoptile von *Avena sativa*. Zeitsch. Bot. **10**: 641-729. 1918.
98. SIERP, HERMAN. Über den Einfluss geringer Lichtmengen auf die Zuwachsbewegung der Koleoptile von *Avena sativa*. Ber. deut. Bot. Ges. **37**: 123-128. 1919.
99. SIERP, HERMAN. Untersuchungen über die durch Licht und Dunkelheit hervorgerufenen Wachstumsreaktionen bei der Koleoptile von *Avena sativa* und ihr Zusammenhang mit den phototropischen Krümmungen. Zeitsch. Bot. **13**: 113-172. 1921.
100. SIERP, H., and A. SEYBOLD. Untersuchungen über die Lichtempfindlichkeit der Spitze und des Stumpfes in der Koleoptile von *Avena sativa*. Jahrb. Wiss. Bot. **65**: 592-610. 1926.
101. STEINBAUER, GEO. P. Growth of tree seedlings in relation to light intensity and concentration of nutrient solution. Plant Physiol. **7**: 742-745. 1932.
102. STRASBURGER, E. Text book of botany. London, 1930.
103. STUTZER, A., and S. GOY. Der Einfluss der Beschattung des Tabaks auf verschiedene Bestandteile der Blätter. Biochem. Zeitsch. **56**: 220-229. 1913.
104. SUZUKI, V. On the formation of asparagine in plants under different conditions. Bull. Col. Agr. Tokyo. **2**: 409-457. 1896.
105. TEODORESCO, E. C. Observations sur la croissance des plantes aux lumières de diverses longueurs d'onde. Annales Sci. Nat. Bot. X. **11**: 201-335. 1929. (Extensive bibliography.)
106. THATCHER, R. W. The influence of shade upon the composition of plants. Jour. Ind. and Eng. Chem. **1**: 801-802. 1909.
107. THATCHER, R. W., and H. R. WATKINS. The effect of shade during ripening on the proximate constituents of the wheat kernel. Jour. Amer. Chem. Soc. **29**: 764-767. 1907.
108. TOKAREWA, A. Über stickstoffhaltige Extraktivstoffe etiolierter *Lupinus-luteus*-Keimlinge. Hoppe-Seyler's Zeitsch. Physiol. Chem. **158**: 28-31. 1926.
109. TOTTINGHAM, W. E., and H. LOWSMA. Effect of light upon nitrate assimilation in wheat. Jour. Amer. Chem. Soc. **50**: 2436-2445. 1928.
110. TOUMEY, J. W. The vegetation of the forest floor; light versus soil moisture. Proc. Intern. Congr. Plant Sci. [Ithaca] **1**: 575-590. 1929.
111. TOUMEY, J. W., and R. KIENHOLZ. Trenched plots under forest canopies. Yale Univ. For. Sch. Bull. **30**. New Haven. 1931.
112. TOUMEY, J. W., and E. J. NEETHLING. Insolation, a factor in the natural regeneration of certain conifers. Yale Univ. Sch. For. Bull. **11**. 1924.
113. TRUMPF, C. Ueber den Einfluss intermittierender Belichtung auf das Etiollement der Pflanzen. Bot. Arch. **5**: 381-410. 1924.
114. TRUMPF, C. Ueber das Wachstum von *Phaseolus*-Keimlingen in Press-Saft normaler und etiolierter Pflanzen. Bot. Arch. **5**: 410-412. 1924.
115. TYSDAL, H. M. Influence of light, temperature and soil moisture on the hardening process in alfalfa. Jour. Agric. Res. **46**: 483-513. 1933.
116. TYSON, JAMES. Influence of soil conditions, fertilizer treatments and light intensity on growth, chemical composition and enzymic activities of sugar beets. Mich. St. Coll. Agric. Tech. Bull. **108**. 44 pp. 1930. (46 references.)
117. VINSON, C. G. Growth and composition of some shaded plants. Proc. Amer. Soc. Hort. Sci. **20**: 293-294. 1923.
118. VOGT, ERNST. Über den Einfluss des Lichts auf das Wachstum der Koleoptile von *Avena sativa*. Zeitsch. Bot. **7**: 193-270. 1915.
119. WIEMANN. Influence of light on the absorption of nutrients by young rye plants. Zeitsch. Pflanzenernähr. Düngung **4**: 153-155. 1925.

120. WIESNER, JULIUS. Der Lichtgenuss der Pflanzen; Leipzig, 1907. (Extensive bibliography.)
121. WILSON, J. K. Nodule production on etiolated vetch seedlings. *Phytopathology* **21**: 1083-1085. 1931.
122. ZILLICH, RUDOLPH. Über den Lichtgenuss einiger Unkräuter und Kulturpflanzen. *Fortsch. Landwirtsch.* **1**: 461-470. 1926.
123. ZON, R., and H. S. GRAVES. Light in relation to tree growth. U.S. For. Serv. Bull. 92. 1911. (Extensive bibliography.)

Manuscript received by the editor April, 1934.

EFFECTS OF DIFFERENT REGIONS OF THE VISIBLE SPECTRUM UPON SEED PLANTS

H. W. POPP AND F. BROWN

Department of Botany, The Pennsylvania State College, State College, Pa.

Introduction. Growth and development: General studies—Effects of different regions of the spectrum on fresh and dry weight of plants and on chemical composition. Miscellaneous effects of different regions of the spectrum: Effect of different parts of the spectrum on transpiration—Effect of quality of light on stomata—Anthocyanin formation in different parts of the spectrum—Quality of light and absorption of inorganic salts. Reflection, absorption, and transmission of different parts of the spectrum by leaves. Concluding remarks. References.

INTRODUCTION

From time to time since the experiments of Tessier (48), studies have been made of plants grown under colored screens. In general, the earlier workers were more interested in the possible use of colored glass for greenhouses than in physiological effects of radiation. Consequently their experiments were comparatively crude. Often the only condition mentioned in their reports was the color of the glass used. The presence of radiation consisting of wave-lengths other than those of the color of the glass, intensity differences, and temperature differences were often ignored, yet rather extravagant claims were often made for a particular color of glass. As a striking example of this may be mentioned a paper by Pleasanton (32) read before the Philadelphia Society for Promoting Agriculture, entitled "On the Influence of the Blue Color of the Sky in Developing Animal and Vegetable Life." (Very appropriately this report was reprinted on blue paper.) Pleasanton began his experiments with grapes in 1861, in a greenhouse, concerning which he says: "At a venture I adopted every eighth row of glass on the roof to be violet-colored, alternating the rows on opposite sides of the roof, so that the sun in its daily course should cast a beam of violet light on every leaf in the grapery." No other conditions of radiation are given and no controls were used. In this special house the author claims to have produced grape vines which in five months were 45 ft. long and 1 in. thick. During the second year these vines produced about 1200 lb. of grapes and during the third year 2 tons, whereas grapes not so treated, according to the author, normally require five to six years before any grapes at all are produced.

Pleasanton's results with grapes led him to experiment further with hogs and with a bull calf, with both of which equally phenomenal results were obtained. In his final statement he says:

"These, gentlemen, are the experiments about which your curiosity has been excited. If by the combination of sunlight and blue light from the sky, you can mature quadrupeds in 12 months with no greater supply of food than would be used for an immature animal in the same period, you can scarcely conceive of the immeasurable value of this discovery to an agricultural people! . . . In regard to the human family, its influence [*i.e.*, blue light] would be widespread . . . you could not only in the temperate regions produce the early maturity of the tropics, but you could invigorate the constitutions of invalids and develop in the young, a generation, physically and intellectually, which might become a marvel to mankind. Architects would be required to so arrange the introduction of these mixed rays of light into our houses that the occupants might derive the greatest benefit from their influence. Mankind will then not only be able to live fast, but they can live well and also live long."

If "ultra-violet radiation" were substituted for "blue light" in this statement, it would sound not unlike many of the more recent accounts of "the powerful ultra-violet ray."

While Pleasanton's paper is undoubtedly an extreme case, it does illustrate the inaccuracy of the work of this period. It is not surprising that there was little agreement among different investigators as to results obtained with glass of different colors. It was not until comparatively recently that improved methods of making glass and better instruments for measuring and controlling radiation made it possible to conduct more exact and more reliable experiments.

Except for a few outstanding cases, the present review will be restricted to the more recent work on the effect of different regions of the visible spectrum on seed plants. Since the relation of light to photosynthesis, chlorophyll development, seed germination, enzymes, and general metabolism, and the effect of radiation on lower organisms are being considered elsewhere in this monograph, they will in general be omitted here. This discussion will center around growth and development, composition, fresh and dry weight, miscellaneous physiological effects, and reflection, absorption, and transmission of radiation by leaves.

GROWTH AND DEVELOPMENT

GENERAL STUDIES

Pfeffer (30) summarizes the status of the question of the effect of rays of different wave-lengths up to his time when he says:

"Although the less refrangible rays are most active in photosynthesis, it is the more refrangible ones (blue to ultra-violet) which exercise the greatest influence upon growth and upon irritable movements or curva-

tures. Hence the shape and growth of a well-nourished plant remain the same behind a solution of cupric oxide in ammonia as in somewhat weakened white light, whereas behind a solution of potassium bichromate, which allows the red and yellow rays to pass, but cuts off the blue and ultra-violet ones, flowering plants turn green, but otherwise grow as though in darkness or in very feeble light."

While it was recognized by Pfeffer and many others that the red end of the spectrum had an etiolating effect on plants, many of the earlier workers interpreted the greater height or stem length of the plants under these conditions as a favorable growth effect and therefore stated that the best plants were produced under red light. Thus, throughout Flammarion's (12) work of over 15 years, he repeatedly reports best growth under red light, although he himself found that the weight of plants was usually greater under clear glass than under any other type. Flammarion grew plants in hothouses under red, green, blue, and clear glass, respectively. Of these, the red glass was the most nearly monochromatic. The hothouses were ventilated so as to overcome wide differences in temperature. Even when an attempt was made to equalize intensities under red and under clear glass, red light produced much taller plants, but with thinner stems and much lower in weight. Blue light always resulted in weak, undeveloped plants of very low weight, probably because of the low quantity of radiant energy transmitted. Flammarion used many kinds of plants and studied also effects of different colors of light on flowering, fruiting, coloration, transpiration, and to some extent on composition.

Corbett (7) supplementing daylight with green, blue, and red light in a greenhouse at night, obtained a marked stimulating effect of red light on lettuce. Green and blue lights were not stimulating. It is not possible in this work to separate photoperiodic effects from quality effects of light. Teodoresco (46), Kraus (22), Vines (52), Hood (17), Zacharewicz (55), Villon (51) and others conducted experiments with colored light in this early period. Without going further into the details of their work, some of which was very extensive, it is important to note that none of it could be absolutely relied upon as regards effect of quality of light on growth because of the constant differences in total radiation intensity, duration of light, temperature, and other factors that were not taken into account.

In 1918 Schanz (37) reported the first of a series of experiments in which he studied the effect on plants of withholding from them definite regions of the spectrum in the blue-violet end. In this paper he tried to prove particularly that ultra-violet radiation influences the configuration of plants in general, by checking their growth. This conclusion was reached by comparing the height of plants in high altitudes with that of the same species growing in lowlands, and also by growing plants in beds covered with window glass, Euphos glass, and red glass, respectively,

and comparing their growth with that of plants similarly grown in the open. With all the species he used, including beans, soy beans, begonias, heliotrope, edelweiss, rye, oats, potatoes, and others, the plants were tallest under the red glass, next tallest under Euphos glass, and shortest in the open. In other words, they became the taller, the greater the section of the spectrum that was cut off from them in the blue-violet end.

The following year, Schanz (38) gave an account of a more detailed investigation in which his experimental plants were grown in eight beds, each receiving a different kind of light. In the first five of these beds the range of wave-lengths of light, transmitted by the screens used, was gradually decreased from the ultra-violet end of the spectrum toward the red. This enabled him to study more carefully the effect on plants of light from which greater and greater regions of the spectrum were eliminated in the blue-violet end. In the last three beds he used combinations of colored glasses which gave predominating colors of yellow, green, and blue-violet, respectively. The characteristics of the screens used in the beds are given in Table 1.

TABLE 1.—SCREENS USED BY SCHANZ

Bed	Screen	Lower limit of transmission, Å	Predominating color
1	None	About 3000	
2	Ordinary window glass	3200	Clear
3	Thin Euphos <i>a</i> glass	3800	Light yellow
4	Thick Euphos <i>b</i> glass	4200	Yellow
5	Thick red glass	5600	Red
6	Yellow glass + Euphos <i>b</i>	Yellow
7	Green glass + Euphos <i>b</i>	Green
8	Blue-violet glass	Blue-violet

Here again he found that the more the short rays were cut off from the plants, the taller they became. Cucumbers, *Fuchsia*, chrysanthemums, *Lobelia*, *Begonia*, and *Oxalis* gradually increased in height from beds 1 to 5, reaching a maximum in red, and fell off in height gradually from beds 6 to 8. Not all species responded in the same manner in beds 6 to 8. Potatoes and beets were weakest in yellow light (bed 6), a little stronger in green light (bed 7), and still larger and healthier in blue-violet light (bed 8). Leaves of *Petunia* were surprisingly large, those of *Oxalis esculenta*, surprisingly small in the green light of bed 7.

When plants were set out in the open from the different beds, the time of flowering was hastened gradually, and the number of flowers and fruits increased from beds 1 to 4. That is, the plants that had been grown in the absence of all ultra-violet and some of the violet blossomed first and produced the greatest number of flowers and fruit. In red, yellow,

green, and blue-violet light (beds 5 to 8) the number of flowers was greatly reduced and the time of blooming postponed.

As a general result of his work, Schanz concluded that light of short wave-lengths, particularly the ultra-violet region, was detrimental to the growth of plants. Hence he recommended the use of Euphos glass for greenhouses.

Schanz's work was in some respects different from that of his predecessors, but it is unfortunate that he made no attempt to equalize intensities in the different beds and that he gave no accurate information concerning temperature differences. There is consequently no way of differentiating in his work between effects of quality of light and effects of intensity. Furthermore, the criterion he most commonly used for best growth was stature of plants, which has since then been shown to be very unreliable.

In 1926, Popp (34) reported the results of his investigations, in which the effect of different regions of the spectrum was studied under approximately equal intensities of radiation. His plants were grown in five small greenhouses, each covered with a special type of glass. The spectral ranges of the glasses used are given in Table 2.

TABLE 2.—SPECTRAL LIMITS OF GLASSES USED BY POPP

House	Glass screen	Spectral range, Å, visible and ultra-violet
1	Ordinary greenhouse glass	3120 to 7200
2	Corning G86B	2960 to 7200
3	Corning Noviol "O"	3890 to 7200
4	Corning Noviol "C"	4720 to 7200
5	Corning G34	5290 to 7200

The intensity of radiation in house 2, which transmitted practically all wave-lengths in sunlight, was reduced, by means of tobacco shading cloth, to a value intermediate between the intensity of the light in houses 4 and 5. Thus it was possible to compare, under approximately the same total intensities, plants from which the blue-violet end of the spectrum was screened out, with those receiving the full spectrum. A wide variety of plants was selected, including tobacco, carrots, tomatoes, buckwheat, Sudan grass, soy beans, sunflowers, petunias, and four-o'clocks.

Most striking results were obtained in house 5, in which all wave-lengths shorter than 5290 Å were eliminated. The plants in this house as compared with those of house 2 receiving the full spectrum, all showed a more rapid rate of elongation during the first two to three weeks of growth. Soy beans, tomatoes, four-o'clocks and *Coleus* attained the greatest final

height in this house, while sunflowers, buckwheat, petunias, and Sudan grass had the lowest final height. The soybeans actually became twiners. All stems, however, were much thinner in this house and had fewer branches. The leaves were curled or rolled, and both stem and leaf tissues were poorly differentiated, having thin-walled cells that were less compact than the cells of leaves and stems of plants receiving the full spectrum. There was a poor development of vascular tissue and of all storage organs. Time of flowering was delayed and the number of flowers, fruits, and seeds greatly reduced in house 5. Fresh and dry weights decreased and percentage of moisture increased. Chlorophyll developed normally, but anthocyanin development was greatly reduced. There were also important changes in carbohydrates and in nitrogen compounds.

The same effects were produced to a lesser degree in house 4 which eliminated all wave-lengths below 4720 Å, but none of them were produced when only ultra-violet radiation was eliminated (house 3).

The effects produced by eliminating the blue-violet end of the spectrum were similar to etiolation produced by greatly reduced intensity. In these experiments, however, there is unquestionable proof that this etiolation was produced by quality of light rather than by total intensity. The results as a whole indicated clearly that the blue-violet end of the spectrum is necessary for normal, vigorous growth of plants. They also indicated that ultra-violet radiation is not necessary, although it may not be without influence. Any influence it may have, however, is rather one of checking elongation of stems, than one of promoting growth in length.

Popp's work was the first in which intensity and temperature were sufficiently controlled to enable one to be certain that the effects produced were actually effects of quality of light. It is none the less interesting that his work does to some extent agree with the earlier findings, namely, that the red end of the spectrum promotes stem elongation, while the blue-violet end checks it. However, the stems produced in the presence of blue-violet rays, while they may be shorter, are much heavier and actually represent more growth in weight. This latter fact was generally overlooked by the earlier workers.

Popp, in his work, considered the possibility of growing some plants under blue-violet light in the absence of the red end of the spectrum. This was not done, however, because it was impossible to obtain a screen which would eliminate the red end of the spectrum and at the same time transmit sufficient total energy to satisfy the needs of the plant. Later, Shirley (43), working in the same houses Popp used, did use in one of the houses a blue glass (Corning G403 ED) which transmitted wave-lengths between 3740 and 5850 Å. This glass, however, transmitted only about 10 per cent of the total energy of sunlight; hence he had to cut down the intensity of all houses to this low figure to get comparable results.

Under these conditions the blue-violet end of the spectrum proved to be somewhat more efficient in dry-weight production of plants than the red end, but not nearly so efficient as the full spectrum under the same total intensity. The plants in the blue house were somewhat stunted, having very short internodes, but sturdy stems. The blue end of the spectrum, therefore, seemed to be more efficient in producing a plant of normal stature and growth than did the red end, when only 10 per cent of the total intensity of daylight was transmitted by each. What would happen if plants could be supplied with light consisting exclusively of the blue-violet end of the spectrum at an intensity comparable to that of daylight has never been determined. At the present time no satisfactory method is available for attacking this problem.

Shirley (43) also grew plants under approximately the same conditions Popp used and arrived at practically the same results.

Pfeiffer (31) studied anatomically stems and leaves of plants grown in the different houses used by Popp and Shirley. Unfortunately, the intensities of radiation were not equalized in the different houses and hence, except for the two houses in which intensities were about the same, namely, the one covered with Noviol "O" which eliminates only ultra-violet, and the full-spectrum house, there is no way of differentiating in her work, as she herself points out, between intensity effects and quality effects. She did, however, find the same lack of differentiation of tissues and weaker development of stem and leaf tissues when the blue-violet end of the spectrum was eliminated, as has been mentioned previously. Vascular development was always best in the full spectrum. When only ultra-violet radiation was eliminated, stems and leaves of four-o'clocks, sunflowers, and soy beans were somewhat thinner, and perhaps somewhat weaker in vascular development.

Teodoresco (47) also states that plants developing under red-orange light show a growth comparable to that in darkness, while plants exposed to blue-violet light resemble those developed in white light, even though grown under lower total intensities. Blue light, according to him, retards growth in length of stems and petioles but favors growth in surface and in thickness of leaves. An exception to this was found in *Menispermum Cocculus*, the petioles of which were shorter in red light and in darkness than in blue light or white light. He also found that more internodes are developed in red light and in darkness than in blue light or white light. In general, his results on the higher plants agree with those of Popp and Shirley. Much of his work was with Bryophytes and is therefore outside the scope of this review.

Funke (13) has also published a rather extensive paper on the effect of light of different wave-lengths on the growth of plants. He worked chiefly with water plants and moor plants. While, after a fashion, he does give the transmissions of the screens he used (gray, red, green, and

blue glass, respectively), his plants were grown in small cupboards under one-sided illumination from the north through a plate glass, the transmission of which is not given. Probably all of the plants suffered from want of light. Hence, there is no accurate way of evaluating results under the different screens. If the results can be relied upon at all, apparently water and moor plants respond to the different regions of the spectrum in the same way as do other higher plants.

Hibben (15) studied the effect of different regions of the spectrum by using an artificial light source. Most of the other investigators have not attempted this because, except on a very small scale, it is not possible to provide an artificial light source which will have a sufficient intensity, after it passes through colored glasses, to satisfy the needs of plants for normal growth. The artificial sources used by Hibben consisted of Mazda lamps and a 480-watt mercury vapor "M" tube. The plants were grown in small compartments. The illumination intensity in the compartments in which Mazda lamps were used is given by Hibben as 350 foot-candles, that in the mercury-vapor-lamp compartment as 150 foot-candles. Both these intensities are so far below the intensity of daylight, even in February and March, the time at which his experiments were carried out, that it is not surprising that Hibben found that his experimental plants often became taller than those in an ordinary greenhouse. The criterion for growth was exclusively height of plants. Furthermore, the tests were continued for only 20 days, which is not long enough for the plants to have become independent of the stored food reserves in the seed. The filters used by Hibben were all Corning glasses. G-38 transmitted wave-lengths down to 4500 Å; G-124J transmitted down to about 3400 Å and was opaque to some of the infra-red; and G-584 transmitted between 3400 and 6500 Å. Of these three, the G-38 glass, which eliminated violet and ultra-violet, gave the tallest plants in the cases of corn, beans, geraniums, nasturtiums, and marigolds, and the G-584, bluish-green glass, usually gave the shortest. Plants under the mercury-vapor lamps were unhealthy.

Hibben states that the speed of growth of plants grown under unscrined Mazda lamps and 500 foot-candles intensity was about double that of plants in the greenhouse receiving daylight. While this is probably partly an intensity effect, it is also probably caused in part by the deficiency of blue-violet radiation in the Mazda lamps. Hence this greater elongation is similar to what results when plants receive daylight screened through a glass that eliminates blue-violet radiation. It should, of course, be emphasized that an increased rate of elongation usually means a decreased dry weight and a less sturdy plant.

Many other workers have grown plants entirely under artificial lights. The most extensive experiments have been carried out at the

Boyce Thompson Institute. Arthur *et al.* (2) in some of their experiments increased the intensity of the blue-violet end of the spectrum by using carbon arcs or mercury-vapor arcs in combination with Mazda lamps. Such a combination gives a type of radiation more nearly like the quality of daylight.

EFFECTS OF DIFFERENT REGIONS OF THE SPECTRUM ON FRESH
AND DRY WEIGHT OF PLANTS AND ON CHEMICAL COMPOSITION

In the previous section on growth and development, little was said concerning fresh and dry weight of plants because many of the investigators did not use such data as a basis for measuring growth. In the final analysis, weight increase is often a better measure of growth than is height. Very often, when the earlier investigators did furnish data on weight and composition, the results could not be depended upon because of poorly controlled conditions. It may, none the less, be interesting to note some of their results and to compare them with later work.

Flammarion (12) in his studies did observe that, although plants grown under red light were taller, they were always lower in weight than those grown under clear glass. His plants grown under blue glass were always not only stunted, but also much lower in weight. Here, however, the principal cause was probably greatly reduced intensity. Lubimenko (24), on the other hand, found that the blue and violet rays were more favorable to the accumulation of dry substance than the red ones. This is in accord with the later and more accurately controlled experiments of Popp (34) and Shirley (43) which will be considered presently.

Among the other workers who have emphasized weight and composition may be mentioned the following: Dumont (10, 11), Bassalik (3), Canals (6), and Hosterman (18). Dumont covered equal areas of wheat already in full flower with frames containing black, clear, red, green, and blue glasses, respectively. The plants were kept covered until the grain ripened. Determinations of various nitrogenous substances in the grain and the heads indicated that those ripened under the red glass were lowest in nitrogen content. The author concluded that the more refrangible rays of the visible spectrum promoted translocation of nitrogenous materials to the ripening grain and favored the formation of albuminoids. Bassalik found a higher content of oxalic acid in *Rumex acetosa* in red light than in blue light, but both red and blue gave lower values than white light. Canals found that the essential oil, thymol, was more abundant in *Thymus vulgaris* grown under blue glass than under red glass, but not so abundant as that grown under white glass or in the open air. Hosterman reported increased numbers and weight of cucumbers grown in sunlight supplemented by the red

light of a neon lamp. None of these workers has given sufficient data concerning the light conditions operating to enable one properly to evaluate the results with respect to quality of light.

Special emphasis was given to determinations of fresh and dry weight and chemical composition in the experiments of Popp (34) already referred to. In general, when wave-lengths shorter than 5290 Å were eliminated (house 5), the most marked differences occurred in fresh weight, dry weight, and composition. Reductions in absolute amounts of all substances were more marked than differences in the relative percentages of constituents determined by analysis. A considerable decrease in the amount of starch and total carbohydrates was noted for most plants, and an increase in the amount of total nitrogen. In both stems and leaves of tobacco plants and in entire tops of sunflower plants, total soluble nitrogen was highest in houses 4 and 5, that is, in the absence of the blue-violet end of the spectrum.

Almost without exception the fresh weight and the dry weight of the plants as a whole, or of any part of the plants, were lowest in houses 4 and 5. With the exception of soy beans, the percentage of moisture in the plants in these two houses was greater than that of the plants in the other houses. The difference in soy beans was due to their greater maturity. Carrots, petunias, sunflowers, and *Coleus* had the greatest fresh weight in house 3 which eliminated only ultra-violet, while tobacco, four-o'clocks, tomatoes, and Sudan grass had the greatest fresh weight in the full-spectrum house—house 2. On the basis of dry weight, the amount of growth made in all plants when the blue-violet end was eliminated was decidedly less in spite of the fact that the total intensity under these conditions was little different from that of the full-spectrum house.

Shirley (43) calculated, from Popp's data, the dry weights which the plants would have attained if they had been grown under 100 per cent light intensity, and from this the dry weight per unit intensity for the various regions of the spectrum. From this he concluded that plants grown under the complete solar spectrum had the advantage over the others, that is, that the plants receiving the full spectrum produced a greater dry weight per unit intensity than did the plants in any other house. This calculation and conclusion, however, are based on the false assumption that the rate of increase in dry weight would remain directly proportional to intensity up to 100 per cent, or full intensity. There is no justification for this assumption, since full daylight intensity is probably considerably above the maximum for dry-weight production in plants. Shirley himself reports in the same paper, from his own intensity studies, "At low light intensities the dry weight produced by the plants studied is almost directly proportional to the intensity received up to about 20 per cent of full summer sunlight. At higher intensities the

shape of the curve falls off, shade plants showing a decrease at lower intensities than sun plants." Since the intensities in Popp's houses were in the neighborhood of 50 per cent of full daylight intensity, it is likely that greater intensities would have resulted in very little increased dry weight.

Shirley determined the dry weights of plants grown in the houses used by Popp but with only 10 per cent of the total daylight intensity and with the substitution of a blue glass already mentioned, for the window glass used by Popp, and Corex glass for G-86B. Under these conditions he found that the entire spectrum (plants grown under Corex glass) was more efficient for the production of dry matter than any of the other qualities used. The lowest dry weights were uniformly produced in the houses from which the blue-violet end of the spectrum was eliminated. The blue end of the spectrum, according to his results, was somewhat more efficient in dry weight production than was the red end of the spectrum.

MISCELLANEOUS PHYSIOLOGICAL EFFECTS OF DIFFERENT REGIONS OF THE SPECTRUM

While it is likely that different regions of the visible spectrum may affect differently the various physiological processes of the leaf, and of the plant as a whole, very little accurate information on this subject is available, except with regard to chlorophyll development and photosynthesis, both of which are considered elsewhere in this monograph. A few remarks may be made concerning the effect of quality of light on transpiration, stomatal movement, anthocyanin formation and absorption of inorganic substances.

EFFECT OF DIFFERENT PARTS OF THE SPECTRUM ON TRANSPIRATION

Since the rate of transpiration is so variable a quantity and is conditioned by a whole series of interrelated internal and external factors, many of which are beyond the control of the investigator, it is difficult to obtain a knowledge of the effect of any one factor. Arriving at conclusions concerning the effect of light quality on transpiration is attended with particular difficulty, since experiments with known light-quality differences as the only variable or even the chief variable have been rare.

The literature on the subject is not voluminous. It is assembled and summarized, although perhaps not entirely properly evaluated, in the monograph of Burgerstein (5). Sachs in his lectures on plant physiology and in the second English edition of his textbook considers the status of the problem up to his time. The conclusion reached by Sachs, that we are still in doubt as to whether radiation as such, independently of the higher temperature caused by it, influences transpiration, is still

valid today. Dehérain (9), whose work did not convince Sachs, concluded that light, not heat, determined transpiration, and that the optically brightest part of the sun's spectrum, that is, the red and yellow portions, caused the greatest rate of transpiration. Flammarion (12) obtained maximum transpiration in the orange-yellow region and minimum rate in the violet. On the other hand, Wiesner (54) advanced the idea that the visible portions of the spectrum which have the greatest influence on transpiration are those corresponding to the absorption bands of chlorophyll and that the most effective wave-lengths, therefore, are not the optically brightest ones, but the blue and red ones. The blue region was more effective than the red. Yellow, and especially green light, he found to be least effective. Moreover, he attributed the influence of light on transpiration principally to its heating effect. Wiesner's conclusions were essentially upheld by a number of investigators who followed, including Henslow (14). In none of these investigations were light intensities satisfactorily equalized. In many cases the filters used were not spectroscopically pure. Precautions were not taken to avoid heating effects independent of the radiation under consideration. The sunlight source generally used was a variable quantity.

A more recent investigation in which an attempt was made to correct some of the errors in method and assumption of the earliest workers, particularly those of Wiesner and his supporters, is that of Iwanoff and Thielmann (19). In most of their experiments they used an arc light source behind a ferrous-sulfate solution, used to absorb infra-red radiation, and two color filters. One of these, a copper ammonium sulfate solution transmitted up to wave-length 5350 Å; the other, a potassium bichromate solution, transmitted down to 5500 Å. Since they had no means of measuring the light energy actually absorbed by their experimental objects, the authors determined by means of a thermopile and galvanometer the relative total incident energy and equalized the total intensities of the light energy falling on the leaves by regulating the distance from the light source to them. A great many experiments were performed with detached leaves of *Cyperus alternifolius*, *Libertia formosa*, and *Bromus inermis*. Potted plants of *Cyperus* were also used. Transpiration rates were determined by taking several readings (loss in weight) at 10-, 15-, or 30-min. intervals for each specimen under each condition. The readings represented amounts transpired for short periods only, of about 10 min. duration, since the rate was found to decrease more or less under constant external conditions, as time went on.

The results showed that when leaves or potted plants were transferred from red-yellow to blue-violet light of approximately equal intensity, they always showed a more or less marked increase in rate of transpiration, while if they were transferred from blue-violet to red-yellow light,

the reverse was true. After adjustment had been made following a transfer from one light condition to another the difference in rate in the blue as compared with the red end was never less than 20 per cent and sometimes as great as 50 to 60 per cent in potted plants of *Cyperus*. If leaves were used which had just been killed by immersion in boiling water for 5 min., change from one region of the spectrum to another did not influence the rate of water loss.

From these results, obtained under better controlled conditions, Iwanoff and Thielmann conclude with Wiesner and his supporters that the blue-violet end of the spectrum causes a greater rate of transpiration than does the red end. However, they do not believe that the explanation of this is the greater absorption of this region of the spectrum by chlorophyll, nor that the transformation of this into heat energy is the explanation of the increased rate of transpiration. From their experiments with recently killed green leaves, the rate of water loss from which was not altered by a change in light quality, they conclude that increased transpiration in the blue-violet region of the spectrum must be a function of the living protoplasm and not a result of increased evaporation due to the availability of more heat energy. In other words, they believe that light quality does affect the rate of transpiration, and this because it has a physiological rather than a physical effect on the rate of water loss. It is suggested that the effect of the blue-violet region on the degree of stomatal opening or upon permeability of protoplasm might explain or help to explain its effect. The meager evidence to date on either of these points is inconclusive. Sierp's (45) work, considered in the section on stomata, supports their first assumption.

On the other hand, the general agreement among different investigators that green leaves have a higher percentage absorption of radiation in the blue-violet end of the spectrum would tend to support a physical interpretation. Furthermore, such absorption may be conditioned by the chlorophyll content of the leaf. It is not surprising that the rate of water loss from a living leaf is different from that of a dead leaf, yet this fact by itself does not necessarily prove that the effect of radiation on transpiration is primarily a physiological one.

EFFECT OF QUALITY OF LIGHT ON STOMATA

A number of investigators have attempted to determine the effect of different parts of the spectrum on the movement of stomata. Among these may be mentioned Kohl (21), Darwin (8), Lloyd (23), Sayre (35), and Sierp (45).

Kohl (21) found that stomata were widest open in the red end of the spectrum between lines *B* and *C* and that a second maximum, less pronounced, occurred between line *F* and the lower limit of the visible region. Yellow, green, infra-red, and ultra-violet exerted essentially no influence

on stomatal opening. Darwin's experiments (8) also brought out the marked influence of the red end, but he could obtain no secondary maximum in the other end of the spectrum. Lloyd (23) used, instead of a spectroscope, as Kohl and Darwin had done, two color filters, to obtain different spectral regions. The first, a bichromate solution, transmitted the region between 5400 Å and 7000 Å; the second, a copper ammonium sulfate solution, transmitted the region between 4800 and 4200 Å. Stomata opened behind both filters, but the influence of the red part of the spectrum was stronger than that of the blue. More recently Sayre (35) has carried out a more extensive investigation with more accurately recorded light conditions. He used, with a sunlight source, eleven Corning glass filters transmitting various regions of the visible, ultra-violet, and infra-red. He found that stomata did not open in wave-lengths longer than 6900 Å but could not determine the exact limit of effectiveness in the blue-violet end of the spectrum, as light intensity became the limiting factor. Other regions of the visible transmitted by his filters seemed equally effective. He used no filters, however, which transmitted only the green and yellow regions. In no one of the investigations mentioned above was the intensity of radiation falling on the stomata controlled or measured. Hence, while we may assume from these investigations that stomata will open in either the blue or the red end of the spectrum, they do not give sufficient data to enable us to determine the relative effectiveness of the two regions.

Information on this subject has been supplied by the recent work of Sierp (45) who has carried out a very careful investigation on the opening of stomata in different regions of the visible spectrum. Great precautions were taken not only with the photometric methods but also with the choice and treatment of experimental material. The light source was a "Kinobox" lamp, 500 watt, 110 volt. Radiation from it passed through a 1-cm. layer of 6 per cent CuSO_4 and then through one of five filters (Schott und Gen.), before entering a small circular opening in the experimental chamber. The CuSO_4 layer absorbed most of the infra-red, and the filters each transmitted a different region of the visible spectrum. The maximum transmission of energy through the blue filter occurred at wave-length 4360 Å. For the green filter the maximum transmission point was 5090 Å; for the yellow, 5460 Å; for the orange-yellow, 5780 Å; and for the red, 6440 Å. The total energy actually falling on the stomata under observation was measured by means of a Moll thermopile. With the blue filter, which was the least transparent one, in one series of experiments, this total energy was found to be 0.095 cal./cm.²/min. Hence the total energy transmitted by the other more transparent filters was cut down, by the insertion of photographic plates in the path of the light, to that of the blue filter. In another series, the total energy in all cases was equalized to 0.056 cal./cm.²/min., which

represented the amount transmitted by the red filter. By these means radiation which differed in light quality but not in total energy, reached the stomata.

Observations were made on the stomata of the under surface of living leaves of potted plants of *Helianthus annuus*. The leaves, without being detached from the plant, were clamped lower surface uppermost on a microscope stage. Instead of comparing average measurements on a given number of stomata under each of several different spectral ranges, as previous workers had done, Sierp selected certain stomata for observation and followed the behavior of each stoma as an individual throughout an experiment. This procedure was adopted because of the extreme degree of variability of stomatal behavior not only in different leaves but in the same leaf, under apparently similar conditions. A selected stoma was illuminated for a period of about 4 hr. during the morning of three successive days. On the first and third day the same light filter was used; on the second day, a different one. Otherwise the stoma was kept in darkness. During the periods of illumination, measurements of the width of stomatal aperture were made at 10-min. intervals by means of an ocular micrometer. These measurements were plotted against time.

Under these conditions blue, green, yellow, and orange-yellow light of equal intensities were found to be equally effective in causing stomata to open. However, stomata opened much more slowly in red light than in blue light of the same intensity, and the relation of the final width of the openings was as 100:60. Thus, contrary to the conclusions of all previous workers, who had reported either that the red end of the spectrum was more effective than the blue end or that one region of the visible was as effective as another, Sierp found blue light much more effective than red. On the basis of these results he suggests that the lower rate of transpiration in the red as compared with the blue end of the visible region, as obtained by Iwanoff and Thielmann, might be explained by the failure of the stomata to open as wide in red light as in blue light.

Sierp, like Sayre (35) and others, also found that stomata remained closed under infra-red radiation.

ANTHOCYANIN FORMATION IN DIFFERENT PARTS OF THE SPECTRUM

A relationship between quality of radiation and the development of anthocyanin has been suggested by a number of investigators. In general the blue end of the visible region, the region of the ultra-violet immediately beyond this down to 2900 Å, or both have been associated with its formation. The lower limit of effective radiation has never been definitely established, but it may very well be beyond the shortest visible rays. Ultra-violet effects have not as yet been clearly separated from violet and blue visible effects.

Schanz (38) observed that flowers became paler in color the more the blue-violet end of the spectrum was reduced. Best flower color, where this color was caused by anthocyanin, always occurred in the open. In leaves in which there is an epidermal layer of anthocyanin, as in a reddish-colored lettuce, anthocyanin development was somewhat checked under window glass and failed to develop altogether when wave-lengths shorter than 3800 Å were eliminated. In his beds 3 to 8, inclusive, this lettuce became fully green. Red beets showed a somewhat similar effect, but the petioles remained red in all beds. Begonia leaves became fully green in beds 4 to 8. When any of these plants were transplanted to the open, they immediately developed anthocyanin. From this Schanz concluded that ultra-violet radiation was necessary for the development of anthocyanin in such plants. In Popp's (34) work the greatest reduction in anthocyanin development occurred when not only the ultra-violet, but also the violet and the blue were eliminated. From the fact that some plants develop anthocyanin in the dark, it is obvious that light is not absolutely necessary for its formation, yet it probably does influence the intensity of its development. More accurate work will have to be done before this question can be settled.

A number of workers have used different types of radiation to develop the anthocyanin color in the skin of apples. Pearce and Streeter (29) found that with sunlight as a source, wave-lengths between 3600 and 4500 Å with an optimum at 4100 Å, were the most effective portion of the spectrum during October and November for coloring McIntosh apples. Arthur (1), on the other hand, using various filters and a mercury-vapor arc source, found that in addition to ultra-violet between wave-lengths 3120 and 2900 Å, all of the visible up to 6000 Å was effective in reddening McIntosh apples. Other workers have reported ultra-violet radiation to be the most effective.

A more detailed discussion of the relation of radiation to anthocyanin formation is given by Arthur (Paper XXV) in this monograph.

QUALITY OF LIGHT AND ABSORPTION OF INORGANIC SALTS

That different portions of the visible spectrum affect differently the absorption of inorganic salts by higher plants has been advanced by several investigators.

Nemec and Gracanic (27) report that violet and red light have little effect on the absorption of phosphoric acid, but markedly increase the absorption of K_2O during the first 18 days of the growth of rye plants. The plants were grown under various colored glasses and under clear glass.

Tottingham *et al.* (49) found that increasing the proportion of radiation in the blue end of the spectrum above that emitted by a Mazda

lamp, by supplementary radiation from a carbon arc, promoted the absorption of nitrate by young wheat plants grown in water culture. Potassium proved a more efficient carrier of the nitrate than sodium, which was thought to corroborate the findings of Nemeec and Graeanin concerning increased absorption of potassium under violet light.

REFLECTION, ABSORPTION, AND TRANSMISSION OF DIFFERENT PARTS OF THE SPECTRUM BY LEAVES

The importance of a knowledge of reflection, absorption, and transmission of radiation by plants has long been recognized, but accurate information has been forthcoming only during the last few years. Practically all of the reported investigations have been restricted to a study of leaves, since these organs are probably the most important absorbers of radiant energy in the higher plants, particularly in connection with photosynthesis and transpiration.

A discussion of the relative merits of different methods of measuring reflection, transmission, and absorption of radiation will not be undertaken in this report. The reader desiring information on this subject is referred to the papers by McNicholas (25, 26), Waldram (53), and Nuernbergk (28) as well as to those of the investigators whose work will be mentioned in this report.

Ursprung (50) reviews the work up to 1903 on the physical properties of leaves with respect to light. In many of the earlier investigations no attempt was made to determine reflection, absorption, and transmission of different regions of the spectrum. These factors were considered only in relation to the total energy of the source or the total visible radiation of the source. The most widely quoted of the earlier investigations is that of Brown and Escombe (4) in which an attempt was made to account for all of the solar energy incident to the leaf surface, that is, to draw up a balance sheet of energy income and outgo. Shull (44) criticizes the results of Brown and Escombe on the basis of the fact that they failed to take into account the important factor of reflection from the leaf surface, which his own as well as the measurements of others have shown to be often as great as the amount of radiation transmitted. Seybold (39) and Schanderl and Kaempfert (36) have also criticized the method of Brown and Escombe. Seybold (39) from his own investigation gives the following tentative light-energy balance (Table 3), in which only white light exclusive of infra-red is considered. The figures in parentheses are estimated values; the others, measured.

Seybold himself states that it is not possible to set up a general energy balance because of the great variability of leaves, as well as the variation in the quality of radiation incident upon them. Further discussion of this question will not be considered here, since it falls more logically under the section in this monograph on photosynthesis.

Among the first to study the transmission of leaves in various parts of the spectrum was Knuchel (20). By means of a spectrophotometer he

TABLE 3.—SEYBOLD'S LIGHT-ENERGY BALANCE SHEET

	Leaf	
	White	Green
Incident light energy	100	100
Absorption of colorless constituents of leaf	(40)	(20)
Light reflection	30	10
Pigment absorption	60
Light transmission	30	10

measured the transmission of sun leaves and shade-leaves of hazelnut, linden, and beech, when diffused zenith skylight was the source. In the blue region of the spectrum around 4400 Å, shade leaves transmitted only traces of the incident radiation and sun leaves only 0 to 2 per cent. At about 4720 Å, shade leaves transmitted 5 per cent and sun leaves 2 to 5 per cent. In the green region (about 5200 Å) shade leaves transmitted 16 to 25 per cent and sun leaves 6 to 12 per cent. At 5890 Å the maximum transmission was 19 per cent and at 6520 Å 12 per cent. His figures thus indicated strong absorption by green leaves in the blue-violet end of the spectrum, a fact which has been substantiated by later investigators. Knuchel also found a greater percentage of green and of yellow light in the forest as compared with sky light in the open. This may be explained partly on the basis of the greater transmission of such radiation by leaves and by the scattering of direct sunlight.

Pokrowski (33), using a spectrophotometer, determined the reflection of a number of tree leaves by a comparison with the reflection from magnesium oxide. He also determined the transmission of several leaves of *Tilia parviflora* and *Fraxinus excelsior*. By considering the total incident radiation as one, and subtracting from it the sum of the radiation reflected and transmitted, he obtained figures for absorption at different wave-lengths. In Table 4, we have averaged two series of his measurements for each species and have brought them together into one table for comparison.

It will be seen from this table, and it is shown in Pokrowski's other measurements, that maximum reflection occurred in the green at 5500 Å. This region is also characterized by maximum transmission and minimum absorption, which might be expected from the green color of leaves and is undoubtedly related to the absorptive properties of chlorophyll. On the other hand, as Pokrowski himself points out, the maximum absorption point of the leaves does not correspond to the maximum point of absorption of chlorophyll, which occurs at about 6600 Å. Maximum absorption

and minimum reflection from leaves occurred in the blue end of the spectrum. Reflection in the region between 4500 and 4800 Å (blue), averaged around 5.5 per cent, while between 6200 and 7100 Å (red) it averaged around 6.5 per cent. Pokrowski found that the lower surfaces of leaves reflected more radiation at all wave-lengths than did the upper surfaces. The percentage of reflection of leaves decreased with the age of the leaf in *Tilia parviflora*.

TABLE 4.—REFLECTION, TRANSMISSION, AND ABSORPTION OF LEAVES AS FOUND BY POKROWSKI
(Total incident radiation = 1)

Wave-lengths, Å		4800	5000	5500	6000	6200	6500
<i>Tilia parviflora</i>	Reflection	0.083	0.101	0.170	0.135	0.121	0.104
	Transmission	0.070	0.283	0.176	0.148	
	Absorption	0.829	0.547	0.689	0.731	
<i>Fraxinus excelsior</i>	Reflection	0.024	0.041	0.100	0.070	0.063	0.054
	Transmission	0.044	0.062	0.140	0.096	0.085	0.070
	Absorption	0.932	0.897	0.760	0.834	0.852	0.876

Pokrowski's studies of reflection from leaf surfaces have been, in general, verified by Shull (44) and Hibben (16), both of whom, working independently, used a spectrophotometer and compared the reflection from leaf surfaces with that from magnesium carbonate. Shull, using a wide variety of leaves, obtained maximum reflection of green leaves in the region 5400 to 5600 Å, which amounted to 6 to 8 per cent from dark green leaves and 20 to 25 per cent from light green ones. The amount of reflection decreased with increasing age of the leaf until the chlorophyll concentration reached its maximum and remained constant from that time until autumn. Hibben reported maximum reflection in the region 5500 to 5600 Å, reaching 28 per cent at wave-length 5600 Å, with secondary increases in the blue (4400 to 4600 Å) and in the red (6750 to 7000 Å). Both Shull and Hibben found, like Pokrowski, that the lower surfaces of leaves reflected more light than the upper surfaces. Leaves with white surfaces, according to Shull, reflect all wave-lengths uniformly, regardless of color. With the disappearance of chlorophyll and the appearance of autumn colors, maximum reflection shifts to the red and yellow. Thus, yellow birch leaves were found by Shull to reflect 42 per cent of the incident radiation from the upper surface, with a maximum in the red at 6600 Å. With less completely yellowed poplar leaves he obtained the same total percentage reflection, but the maximum was in the yellow at 5800 Å. Hibben reports maximum reflection from autumn leaves in the region 6000 to 7000 Å and greatest amount of reflection from the most brilliantly colored leaves. Shull, unlike Pokrowski, found in a number of the green leaves tested a decrease in the percentage of reflec-

tion around 6800 Å, which corresponds to the maximum absorption band of chlorophyll.

Among the most comprehensive studies made to date on reflection, transmission, and absorption of radiation by leaves are those of Seybold (39 to 42) and of Schanderl and Kaempfert (36).

Seybold (39) in his first paper presents the results of his determination of transmission percentages of variegated and of green leaves in different parts of the spectrum and also gives some data on the transmission of chlorophyll. His determinations of spectral transmission were made with an artificial light source (a 500-watt "Osram Nitra-Kinoboxlampe") and a Linke actinometer, the effective part of which was a thermopile and galvanometer connected with a photographic recorder. Transmission in different parts of the spectrum was determined by means of a series of Schott filters used in combination with a 6 per cent CuSO_4 solution of 1 cm. thickness to eliminate the infra-red. The transmission values found by Seybold for various species of plants are presented in condensed form in Table 5. A comparison of his figures for *Tilia parviflora* and *Fraxinus excelsior* with those of Pokrowski for these species shows Pokrowski's figures to be considerably higher, especially in the yellow. This is probably to be attributed to the difference in methods used by the two investigators. Seybold's figures also represent a much wider range of the spectrum. From his studies of green leaves, Seybold concluded that figures given for transmission by previous investigators have in general been too high.

Seybold also measured, by means of a sodium photoelectric cell, which was sensitive only to visible and ultra-violet radiation, and with sunlight as a source, the transmission by variegated and green leaves of the region 3500 to 7400 Å. With the total energy of sunlight equal to 1.2 cal./cm.²/min., white portions of variegated leaves transmitted between 20 and 30 per cent, and green portions between 8 and 15 per cent of the incident radiation, leaving a difference of about 10 to 20 per cent to be attributed largely to chlorophyll.

In his second paper Seybold (40) added reflection measurements which, with his transmission measurements, enabled him to determine absorption by the leaf. These measurements were made with the photoelectric cell already mentioned. A concave mirror, elliptical in form, was constructed out of brass and highly polished. The spherical photocell was placed far enough into the concave mirror that a point on its surface corresponded to the focal point of the mirror. At this point a piece of black paper was fastened, to which was added a magnesium carbonate layer. All reflections from leaves were compared with the values obtained with this magnesium carbonate layer considered as unity. Sections of leaves were fastened in the same place on the surface of the photoelectric cell for measurement. The light passed through a hole in

the back of the mirror, to the reflecting surface and from there was reflected to the inside of the mirror and back to the photocell. The same filters were used as have already been mentioned. This method enabled him to take into account the diffusion of the radiation from the surface of the leaf. Table 6 gives the average values Seybold obtained for transmission, reflection, and absorption at different wave-lengths with 10 different species of plants with variegated leaves. Since he used filters with comparatively long ranges of transmission, the wave-lengths given in this table represent approximately only the maximum point of transmission of the filters.

TABLE 5.—TRANSMISSION OF GREEN AND WHITE SECTIONS OF VARIEGATED LEAVES AND OF GREEN LEAVES IN DIFFERENT REGIONS OF THE SPECTRUM IN PERCENTAGE OF INCIDENT RADIATION (Approximate spectral ranges of the filters in μ ., with maximum transmission point in parentheses. CuSO_4 plus BG9 was used with all filters except the white)

Screen color	White		Blue		Green		Yellow		Orange		Red		Infra-red	
Screen	BG9		BG12		VG1		GG11		OG2		RG5		RG7	
λ -range	320-720		320-520		440-650		475-700		560-720		675-720		770-3000	
Approx. max.	(475)		(425)		(540)		(500-550)		(580)		(680)		(2000)	
Sections of leaf	W.	G.	W.	G.	W.	G.	W.	G.	W.	G.	W.	G.	W.	G.
<i>Acer negundo</i>	38	12	18	2	30	13	30	14	30	13	36	24	31	28
<i>Humulus japonicus</i>	28	6	18	1	31	9	41	9	39	9	39	29	36	28
<i>Sambucus nigra</i>	41	7	30	0	41	10	43	6	42	8	40	26	30	18
<i>Funkia fortunei alba marg.</i> ...	39	3	22	1	33	6	41	9	40	6	35	19	33	22
<i>Abutilon</i> sp.....	25	3	10	0	25	4	29	2	30	3	35	14	25	20
<i>Eulalia zebrina stricta</i>	30	9	15	0	34	8	37	8	40	8	40	19		
<i>Phalangium lineare</i>	30	6	20	1	30	10	22	21
<i>Stenotaphrum americanum</i> ...	30	2	23	1	39	2	30	21
<i>Tradescantia fluminensis</i> <i>varieg.</i>	57	12	59	1	59	14	53	12	54	14	53	20	77	48
Green leaves														
<i>Tropaeolum majus</i>	8		1		10		11		11		26		32	
<i>Polygonum Sachalinense</i>	6		1		9		6		7		29		28	
<i>Helianthus annuus</i>	2		1		4		4		6		17		20	
<i>Phaseolus vulgaris</i>	9		1		13		11		13		31		34	
<i>Tilia parviflora</i>	2		1		3		2		1		15		19	
<i>Fragaria excelsior</i>	4		1		6		5		5		21		20	
<i>Corylus avellana</i> (shade leaf)	12		2		15		14		14		24		27	
<i>Corylus avellana</i> (sun leaf)...	3		1		5		6		6		19		16	
<i>Potamogeton alpinus</i> (sub- mersed leaf).....	39		14		30		50		44		51		72	
<i>Potamogeton alpinus</i> (emersed leaf).....	6		1		6		6		7		32		31	

W. = white; G. = green.

From these figures it is apparent that light transmission decreases and absorption increases with decreasing wave-length. Absorption is greater throughout in the green portions of leaves than in the white portions, but

it increases more markedly with decreasing wave-length in the white than in the green portions. That the presence of chlorophyll is responsible for the greater absorption in the green is obvious. Seybold's results with reflection in general approximated those of Shull, Hibben, and Pokrowski, obtained with a spectrophotometer, although the wider spectral ranges used by Seybold tend to obscure the greater reflection of green leaves between 5400 and 5600 Å.

TABLE 6.—AVERAGE VALUES OF TRANSMISSION, REFLECTION, AND ABSORPTION OBTAINED BY SEYBOLD WITH 10 SPECIES OF VARIEGATED PLANTS (In percentage of the incident radiation)

	White leaf-sections					Green leaf-sections				
	644 m μ	578 m μ	509 m μ	436 m μ	336 m μ	644 m μ	578 m μ	509 m μ	436 m μ	336 m μ
Transmission.....	33	33	31	20	8	9	10	10	2	0
Reflection.....	46	47	43	27	18	13	14	14	11	9
Absorption.....	21	20	26	53	74	78	76	76	87	91
Light absorption coefficient.....	0.21	0.20	0.26	0.53	0.74	0.78	0.76	0.76	0.87	0.91

By comparing observed values of absorption with calculated values for green leaves and white portions of variegated leaves, Seybold found that the Lambert-Beer absorption law held for both.

In the third paper of the series, Seybold (41) presents evidence to show that whether the incident radiation used is parallel or diffused makes little difference in the values obtained for transmission or reflection at different wave-lengths. The maximum difference he found for transmission values, when the two types of radiation were used, was 2 per cent. He attributed this partly to the fact that the upper epidermis diffuses the radiation that strikes it and hence, even a parallel beam will immediately be diffused on striking the leaf. It is also interesting to note that when he compared the transmission of fresh-leaf sections with those air-dried for 3 days, there was an increase in infra-red transmission in the dried sections of only 5 per cent, which is less than one would expect from the well-known fact that water absorbs infra-red. By using a yellow filter in combination with CuSO_4 to eliminate infra-red, a similar small increase in transmission occurred in the yellow part of the visible region.

Schanderl and Kaempfert (36), using sunlight exclusively as a source, measured by means of a Linke actinometer containing a modified Moll thermopile, not only the transmission of whole leaves but also the transmission of different leaf tissues, especially different types of epidermises and leaf surfaces, and also determined the effect of the position or orientation of chloroplasts and the presence of assimilation products on trans-

mission. Two filters were used, a yellow glass (Schott and Gen. OG1) having a range of about 5100 to 31,500 Å, and a red glass (Schott and Gen. RG2) with a range between 5900 and 31,500 Å. The transmission in other parts of the spectrum was determined by difference, in a comparison with transmission of the full spectrum of sunlight.

The transmission values they obtained with whole leaves agreed more or less with those of Seybold and others and need not be repeated here. They found, in common with other investigators, that the light that is transmitted by a leaf is entirely diffused when passing out of the leaf, even when the incident beam is parallel; that long-wave radiation is transmitted in greater percentage than short-wave radiation; and that the short rays are diffused most and are most strongly absorbed by chlorophyll. The red portions of a variegated *Coleus* leaf were found to transmit higher percentages of the total incident radiation than were green sections, but they transmitted less of the blue-green and yellow-green components than did green sections.

Schanderl and Kaempfert also found that the transmission values of a leaf at different wave-lengths change as a result of movements and orientation of the chloroplasts. By selecting leaves of *Tradescantia viridis*, *Pelargonium zonale*, *Adiantum cuneatum*, and *Coleus hybridus*, all of which were found to change the position of their chloroplasts under different intensities of illumination, and by comparing the transmission of these leaves in diffused light or darkness with transmission in direct sunlight, they found that 10 to 40 min. in direct sunlight was enough to increase the transmission as much as 40 per cent. The short wave-lengths were found to be influenced most. In the case of *Tradescantia viridis*, the increase in transmission in the blue-violet end of the spectrum was sometimes over 200 per cent. The products of photosynthesis in the leaf were also found to affect the transmission. Accumulation of starch in *Tradescantia* leaves caused a decrease in transmission of the leaf.

A number of previous workers determined the absorptive power of chlorophyll in the leaf by comparing white parts of variegated leaves with green parts. This method was used by Brown and Escombe originally. Schanderl and Kaempfert have shown that this method is not reliable because the white portions of many of these leaves are filled with air, which greatly increases the reflecting powers of the cells and results in lower transmission values. Since this condition does not obtain in the green sections, it cannot be assumed that the colorless parts of the green sections have the same absorptive power as the white sections of the leaf. The extinction coefficient of chlorophyll can, therefore, not be determined by difference. Seybold has also called attention to this. Schanderl and Kaempfert attempted to determine the absorptive power of chlorophyll by comparing the values obtained with green leaves with

those obtained after the chlorophyll had been extracted from these leaves, the same leaf being used for both determinations. This method gave for the chlorophyll absorption 70 per cent in white light, 90 per cent in violet-green, 63 per cent in green-yellow and 68 per cent in red and infra-red. It is doubtful, however, whether this method is much more accurate than the other.

From extensive studies of isolated upper epidermises of leaves of all kinds, Schanderl and Kaempfert (36) obtained maximum transmission values of 98 per cent with epidermises of shade plants and minimum values of 15 to 25 per cent with those of desert plants or plants growing in high altitudes. The latter also caused the incident radiation to become much more diffused than did the former. Colorless epidermises transmitted about equally all wave-lengths, but those containing anthocyanin acted as filters, reducing particularly the percentage of blue-violet radiation. Hairs, resins, or waxes on an epidermis not only caused a pronounced scattering of the incident radiation, thereby reducing markedly the total transmission of the epidermis, but also absorbed more strongly the shorter wave-lengths. The authors call attention to the fact that waxy coatings are commonly found on fleshy fruits and succulent leaves and stems. Since such structures have a high energy-absorbing capacity and hence could be injured more readily by intense radiation than thinner structures, it is suggested that these coatings may serve more to reduce the intensity of the incident energy than to check loss of water by transpiration.

By studying separately the transmissions of the palisade and spongy mesophylls of leaves of *Cyclamen persicum* and *Ficus elastica*, the authors found that if the radiation passing through the palisade and entering the spongy mesophyll is placed at 100 per cent, that of the spongy mesophyll of *Ficus elastica* would be only 5 per cent and that of *Cyclamen persicum* 40 per cent. The lower percentage transmission of the spongy mesophyll is attributed, first, to the fact that it receives only highly diffused radiation, and, second, that it is filled with air spaces that, in many cases, cause total reflection. When the spongy mesophyll was filled with water its transmission power increased. Under ordinary conditions the palisade mesophyll absorbs much more radiation than the spongy mesophyll because of its greater chlorophyll content. The structure of the spongy mesophyll is such, however, as to enable it to utilize much more efficiently the diffused radiation it receives. The presence of hairs and other epidermal coverings on the lower surfaces of leaves is also thought by the authors to cause a reflection back into the leaf of the radiation which would pass out of the epidermis if it were smooth.

The structures of plants are so closely related to their light relations that these authors suggested, instead of the ecological designations

hydrophyte, mesophyte, and xerophyte, which are based on water relations, a classification based on light relations, namely, polyactinophytes, plants of climates with intense radiation; mesoactinophytes, plants in climates with medium radiation intensity, and oligoactinophytes, plants in climates having extensive (or more highly diffused) radiation.

The studies of the various workers mentioned, on reflection, absorption, and transmission of radiation in different parts of the spectrum, should prove of considerable value in interpreting the effect of light on photosynthesis and other physiological processes. It is likewise interesting to note that the blue-violet end of the spectrum, which is uniformly absorbed to a greater extent than the red end, also seems to be more effective in producing a plant of normal stature than does the red end. The red end of the spectrum produces a type of etiolation.

CONCLUDING REMARKS

Viewing as a whole the work that has been done on the effect of quality of light on plants, we find that the behavior of different species is so varied that it will probably never be possible to generalize. There is, however, sufficient evidence to enable one to say with some certainty that the red end of the spectrum stimulates stem elongation, while the blue-violet end checks it. Best growth has uniformly been obtained in the full spectrum of daylight. No other light source and no filter thus far used has proved superior to daylight as normally received by plants. It may be possible, however, to use a particular quality of radiation for obtaining a specific kind of growth. The investigations thus far carried out have yielded much toward an understanding of the *response* of plants to radiation, but much still remains to be done before we shall understand the mechanism of this response. Photochemical studies carried out in connection with growth responses and not restricted to photosynthesis would probably prove enlightening.

REFERENCES

1. ARTHUR, J. M. Red pigment production in apples by means of artificial light sources. *Contr. Boyce Thompson Inst.* **4**: 1-18. 1932.
2. ARTHUR, J. M., J. D. GUTHRIE, and J. M. NEWELL. Some effects of artificial climates on the growth and chemical composition of plants. *Amer. Jour. Bot.* **17**: 416-482. 1930.
3. BASSALIK, K. (Formation of oxalic acid in green plants.) (Trans. title.) *Verh. Schweiz Naturf. Ges. (Jahresversammlung Zürich 1917)* **99**: 226-7. 1918. (*In Chem. Abs.* **14**: 1841.)
4. BROWN, H. T., and F. ESCOMBE. Researches on some of the physiological processes of green leaves with special reference to the interchange of energy between the leaf and its surroundings. *Proc. Roy. Soc. [London] B*, **76**: 29-111. 1905.
5. BURGERSTEIN, A. *Die Transpiration der Pflanzen.* Gustav Fischer; Jena, 1920.
6. CANALS, E. (Effect of different kinds of solar radiation on the formation of essential oils in plants.) (Transl. title.) *Bull. Sci. Ind. Roure-Bertrand fils (IV)* **3**: 8-13. 1921.

7. CORBETT, L. C. The effects of colored light. *Amer. Gard.* **23**: 591. 1902.
8. DARWIN, FRANCIS. Observations on stomata. *Phil. Trans. Roy. Soc. [London] B*, **190**: 531-621. 1898.
9. DEHÉRAIN, P. P. (Dehérain's researches on transpiration) *Ann. des Sci. Nat. Ser. 5*, **12**: 1, 1869. (See Sachs, J. Textbook of botany. Transl. by Bennett and Thistleton Dyer, p. 602. 1875.)
10. DUMONT, J. Influence des diverses radiations lumineuses sur la migration des albuminoides dans le grain de blé. *Compt. Rend. Acad. Sci. [Paris]* **141**: 686-688. 1905.
11. DUMONT, J. Les radiations lumineuses et la richesse azotée du blé. *Compt. Rend. Acad. Sci. [Paris]* **143**: 1179-1181. 1906.
12. FLAMMARION, C. (Action of different colors of light on plants.) *Compt. Rend. Acad. Sci. [Paris]* **121**: 957-961. 1895; see *Bul. Min. Agr., France*, 1895-1902; *Bul. Mens. Off. Renseig. Agr. [Paris]*. 1904-1910. (Excellent account *in* *Exp. Sta. Rec.* **10**: 103-114, 203-213, 613-616. 1898-1899.)
13. FUNKE, G. L. On the influence of light of different wave-lengths on the growth of plants. *Rec. Trav. Bot. Néerl.* **28**: 431-485. 1931.
14. HENSLOW, G. The use of the spectroscopie in the study of plant life. *Jour. Roy. Hort. Soc. [London]* **36**: 82-97. 1910.
15. HIBBEN, S. G. Influence of colored light on plant growth. *Trans. Illum. Eng. Soc.* **19**: 1000-1010. 1924.
16. HIBBEN, S. G. Some light reflecting properties of flowers and foliage. *Trans. Illum. Eng. Soc.* **24**: 752-769. 1929.
17. HOOD, G. W. Some responses to color stimuli by certain plants. *Ann. Rept. Columbus Hort. Soc.* 1910. Pp. 147-166.
18. HOSTERMAN, G. Kulturversuche mit elektrischem Lichte. *Gartenwelt* **26**: 74-75. 1922. [See also *Landw. Jahrb.* **52** (Ergänzungs. 1): 76-78. 1919.]
19. IWANOV, L. A., and M. THIELMANN. Ueber den Einfluss des Lichtes verschiedener Wellenlänge auf die Transpiration der Pflanzen. *Flora* **116**: 296-311. 1923.
20. KNUCHEL, H. Spectrophotometrische Untersuchungen im Walde. *Mitteil. Schweiz. Zentralanst. Forst. Versuchsw.* **11**: 1-94. 1914.
21. KOHL, F. G. Über Assimilationsenergie und Spaltöffnungsmechanik. *Bot. Centralbl.* **64**: 109-110. 1895.
22. KRAUS, G. Versuche mit Pflanzen im farbigen Licht. *Reprint from Sitzungsber. Naturf. Ges., Halle.* 1876. Pp. 4-8.
23. LLOYD, F. E. The physiology of stomata. *Carnegie Inst. Washington. Publ. No. 82.* 1908.
24. LUBIMENKO, W. N. (Relationship between the energy of carbon dioxide assimilation and the formation of the dry substance of green plants under the influence of different colored rays of light.) (Trans. title.) *Verh. XII Versamml. russ. Naturf. und Aerzte* **10**: 524. *Thru. Zentr. Biochem. Biophys.* **10**: 803-4. 1911.
25. McNICHOLAS, H. J. Equipment for routine spectral transmission and reflection measurements. *U. S. Bur. Stand. Jour. Res.* **1**: 793-857. 1928. (Reprinted as *Research Paper No. 30.*)
26. McNICHOLAS, H. J. Absolute methods in reflectometry. *U. S. Bur. Stand. Jour. Res.* **1**: 29-73. 1928.
27. NEMEC, A., and M. GRACANIN. Influence de la lumière sur l'absorption de l'acide phosphorique et du potassium par les plantes. *Compt. Rend. Acad. Sci. [Paris]* **182**: 806-808. 1926.
28. NUERNBERGK, E. Physikalische Methoden der pflanzlichen Lichtphysiologie. *In* Emil Aberhalden's *Handbuch der biologischen Arbeitsmethoden. Abt. XI. Chemische, physikalische und physikalisch-chemische Methoden zur Untersuchung des Bodens und der Pflanze, Teil 4, Heft. 5, Liefg.* 399: 739-950. Urban und Schwarzenberg; Berlin, 1932.

29. PEARCE, G. W., and L. R. STREETER. A report on the effect of light on pigment formation in apples. *Jour. Biol. Chem.* **92**: 743-749. 1931.
30. PFEFFER, W. *Physiology of plants* (Transl. by A. J. Ewart) **2**: 101-106. Oxford, 1903.
31. PFEIFFER, N. E. Anatomical study of plants grown under glasses transmitting light of various ranges of wave lengths. *Bot. Gaz.* **85**: 427-436. 1928.
32. PLEASANTON, A. J. On the influence of the blue color of the sky in developing animal and vegetable life, as illustrated in the experiments of Gen. A. J. Pleasanton, between the years 1861 and 1871 at Philadelphia. Read before the Phila. Soc. for Promoting Agriculture on Wed., May 3, 1871. 9th edition, reprinted by Inquirer Book and Job Print, Phila.
33. POKROWSKI, G. I. Ueber die Lichtabsorption von Blättern einiger Bäume. *Biochem. Zeitsch.* **165**: 420-426. 1925.
34. POPP, H. W. A physiological study of the effect of light of various ranges of wave length on the growth of plants. *Amer. Jour. Bot.* **13**: 706-736. 1926.
35. SAYRE, J. D. Opening of stomata in different ranges of wavelengths of light. *Plant Physiol.* **4**: 323-328. 1929.
36. SCHANDERL, H., and W. KAEMPFFERT. Ueber die Strahlungsdurchlässigkeit von Blättern und Blattgeweben. *Planta, Arch. Wiss. Bot.* **18**: 700-750. 1933.
37. SCHANZ, FRITZ. Einfluss des Lichtes auf die Gestaltung der Vegetation. *Ber. Deut. Bot. Ges.* **36**: 619-632. 1918.
38. SCHANZ, FRITZ. Wirkungen des Lichtes verschiedener Wellenlänge auf die Pflanzen. *Ber. Deut. Bot. Ges.* **37**: 430-442. 1919.
39. SEYBOLD, A. Ueber die optischen Eigenschaften der Laubblätter I. *Planta, Arch. Wiss. Bot.* **16**: 195-226. 1932.
40. SEYBOLD, A. Ueber die optischen Eigenschaften der Laubblätter. II. *Planta, Arch. Wiss. Bot.* **18**: 479-508. 1932.
41. SEYBOLD, A. Ueber die optischen Eigenschaften der Laubblätter. III. *Planta, Arch. Wiss. Bot.* **20**: 577-601. 1933.
42. SEYBOLD, A. Ueber die optischen Eigenschaften der Laubblätter. IV. *Planta, Arch. Wiss. Bot.* **21**: 251-265. 1933.
43. SHIRLEY, H. L. The influence of light intensity and light quality upon the growth of plants. *Amer. Jour. Bot.* **16**: 354-390. 1929.
44. SHULL, C. A. A spectrophotometric study of reflection of light from leaf surfaces. *Botan. Gaz.* **87**: 583-607. 1929.
45. SIERP, H. Untersuchungen über die Öffnungsbewegung der Stomata in verschiedenen Spektralbezirken. *Flora* **128** (n.s. 28): 269-285. 1933.
46. TEODORESCO, E. C. Influence des différentes radiations lumineuses sur la forme et la structure des plantes. *Ann. Sci. Nat. Bot.*, VIII, **10**: 141-256, 257-264. 1899.
47. TEODORESCO, E. C. Observations sur la croissance des plantes aux lumières de diverses longueurs d'onde. *Ann. Sci. Nat. Bot.* X, **11**: 201-335. 1929.
48. TESSIER. Expériences propres à développer les effets de la lumière sur certaines plantes. *Histoire de l'Académie des Sciences de Paris*, 1783, pp. 133-156.
49. TOTTINGHAM, W. E., H. L. STEPHENS, and E. J. LEASE. Influence of shorter light rays upon absorption of nitrate by the young wheat plant. *Plant Physiol.* **9**: 127-142. 1934.
50. URSPRUNG, A. Die physikalischen Eigenschaften der Laubblätter. *Biblioth. Botan. H.* **60**. 1903.
51. VILLON, M. Plants grown under different colored glass. *Gard. Chron.* **16**: 130. 1894.
52. VINES, S. H. (Retarding influence of blue rays on growth). *Arb. Botan. Inst. Würzburg.* **2**: 139. 1878.

53. WALDRAM, J. M. The precise measurement of optical transmission, reflection, and absorption factors. Report Int. Illum. Congress, Saranac Inn, N. Y. 1928.
54. WIESNER, J. Untersuchungen über den Einfluss des Lichtes und der strahlenden Wärme auf die Transpiration der Pflanze. Sitzber. K. Akad. Wiss., Wien, **74**: 55 pages, 1876.
55. ZACHAREWICZ, E. (A comparative study of different colored glass for greenhouses.) Jour. Soc. Nat. Hort. France. 4 ser., **3**: 265-268. 1902 (*Abs. in Exp. Sta. Rec.* **14**: 354. 1902.)

Manuscript received by the editor August, 1934.

XXIII

EFFECT OF THE VISIBLE SPECTRUM UPON THE GERMINATION OF SEEDS AND FRUITS

WILLIAM CROCKER

Historical. Conditions modifying the effect of light upon germination: Seeds that are favored by light—Loranthaceae and other epiphytic forms, Gesneriaceae, Chloris ciliata, Poa, Ranunculus sceleratus, Onagraceae, Lythrum, other seeds. Seeds inhibited by light—Phacelia tanacetifolia, Nigella, Liliaceae, other seeds. Effect of various regions of the spectrum. Dosage of light required. Theories of light action. Summary. References.

HISTORICAL

Early investigators, Ingenhousz 1788, Humboldt 1794, Senebier 1797, Saussure 1804, Heiden 1859 (66, page 432; 79), concluded that light had no effect or a detrimental effect on seed germination. Unfortunately, Ingenhousz, Senebier, and others (79, page 240) worked with light-indifferent seeds such as mustard, beans, and peas. Caspary (11) was the first to claim that light was favorable for the germination of any sort of seed when he found that *Bulliarda aquatica* germinated well in full sunlight but poorly in diffuse light. This work must have been overlooked, for in his "Handbuch der Samenkunde" Nobbe stated that all previous investigators had found sunlight not only unnecessary but even injurious for initiating germination. He suggested that the detrimental effect of light might be due to excessive heating and evaporation.

Peyritsch and Wiesner (103, pages 182 and 183) found light necessary for the germination of *Viscum album* seeds. Kraus reports that in 1878 Wagner (55, page 410) had shown that light favored the germination of *Poa* achenes, but it was Stebler's work in 1881 (92) on the favorable action of light on the germination of various grass achenes that gave the great stimulus to investigation in this field and aroused the antagonism of Nobbe. Stebler found that under controlled temperature conditions *Poa nemoralis* gave 1 to 3 per cent germination in darkness and 53 to 62 per cent in daylight, while *P. pratensis* gave 0 to 7 per cent in darkness and 59 to 61 per cent in light. Light from a gas lamp proved as effective as sunlight. Light favored the germination of various other genera of grasses: *Festuca*, *Cynosurus*, *Alopecurus*, *Holcus*, *Dactylis*, *Agrostis*, *Aira*, *Panicum*, and *Anthoxanthum*. Quick-germinating seeds such as beans, peas, and clovers were indifferent to light. Stebler mentioned that Leitgeb and Borodin had found light necessary for the germination of spores of some liverworts and ferns, and Pfeffer for the germination of the gemmae of *Marchantia polymorpha*.

Nobbe (80) vigorously contradicted Stebler's results. He reported that seeds of *Poa pratensis*, *Phleum pratense*, and *Zea mays* germinated better in darkness than in light and that seeds of *Dactylis glomerata* germinated equally well under both conditions. He drew the sweeping conclusion that the method of seed testing in darkness found in nature was reliable even for grasses and preferable to testing in light, since under identical conditions the process in darkness was quicker, more certain, and more regular, and constant temperature and moisture conditions were easier to maintain.

Nobbe's opinion did not long dominate the field, for Liebenberg (69), Jönsson (45), Weinzierl (99), Laschke (59), Hiltner (42), and Pickholz (84) extended and confirmed Stebler's results in their studies of the effects of after-ripening and constant and intermittent temperatures on light-sensitiveness of grass seeds. Later investigations have shown that the germination of seeds of many plant families, gymnosperms as well as angiosperms, is favored by light. A large number of internal and external conditions modify the sensitiveness of seeds to light, or even annul or reverse the light effects. Among these factors are maturity of the seeds, stage of after-ripening, condition and integrity of the seed coats, region where the seed grew, partial oxygen pressure, temperature of the germination bed, whether constant or fluctuating, acidity of the substratum, and the presence of nitrates or other nitrogen compounds. Lehmann and Aichele (66, pages 432 to 461) give an excellent critical summary of the early literature on the effect of light on seed germination.

While for the germination of many sorts of seeds light is required or favorable, it is detrimental to the germination of some other kinds. Heinricher (34) found that darkness increased the germination velocity and percentage of seeds of *Acanthostachys strobilacca*. Light proved especially detrimental to germination capacity. Remer (88) showed that diffuse light reduced to a marked degree the germination of *Phacelia tanacetifolia* seeds. In full sunlight under similar temperature and moisture conditions seeds covered with 0.5 to 1 cm. of soil gave 97 per cent germination, and seeds on top of the soil gave 15 per cent germination. Following Remer's work many investigators studied the germination of *Phacelia* seeds in light and darkness under many conditions. Seeds of *Phacelia tanacetifolia* became the classical example of light-inhibited seeds.

Kinzel (46), in 1907, found that *Nigella sativa* needed darkness for good germination. Later investigations by Kinzel and others showed that the germination of various species of *Dianthus* and *Allium*, *Lychnis lapponica*, *Soldanella alpina*, *Primula spectabilis*, and many others was hindered by light.

CONDITIONS MODIFYING THE EFFECT OF LIGHT UPON GERMINATION

In no other field of plant physiology is there as much disagreement in results as in the effect of light upon germination. For seeds of a given species of plant one author may find light favorable, another may find it indifferent, and a third detrimental. Most of these discrepancies can be explained by the manner in which the internal and external conditions mentioned above modify the sensitiveness of seeds to light. The effect of these conditions and the significance of phylogenetic and ecological relationships upon light sensitiveness of seeds can best be understood by considering in detail a number of the seeds that have been most investigated. Let us discuss first several kinds of seeds that are favored in germination by light and then several sorts that are hindered.

SEEDS THAT ARE FAVORED BY LIGHT

Loranthaceae and Other Epiphytic Forms.—Since Peyritch and Wiesner (103, pages 182 and 183) discovered that light was necessary for the germination of *Viscum album* seeds, seeds of several other Loranthaceae have been studied as to their behavior toward light and other factors. Seeds of epiphytes belonging to other families of plants also have received some attention.

Wiesner (104) showed that the germination of *Viscum album* seeds increased with light intensity. His experiment extended from March 24 to April 22. During this period the intensity of the daylight varied from 0.016 to 0.375 of a Wiesner chemical light unit. With an intensity of 0.142 of a unit seeds gave 42 per cent germination; with 0.024 of a unit, 25 per cent; with 0.015 of a unit, 5 per cent; and with 0.0013 of a unit, 0 per cent. The minimum intensity necessary for the germination of *Viscum album* seeds was about 0.04 of the maximum intensity of sunlight at Vienna during the germination period. The germination percentage increased as the light intensity rose, to approximately one-half the maximum intensity of sunlight during that period. In continuous darkness the seeds died within a few weeks. The minimum intensity necessary for growth of the hypocotyl was a little lower than for germination, and the rate of growth of this organ also increased with increased light intensity. The seeds germinated in the mucilaginous fruits if the light intensity was adequate.

Wiesner (105) made a fuller study of the germination of seeds of two European mistletoes, *Viscum album* and *Loranthus europaeus*, and of four tropical species, *Viscum articulatum*, *V. orientale*, *Loranthus repandus*, and *L. pentandrus*. Seeds of the two European species were surrounded by fruits rich in mucilage, required light for germination, would not germinate in the presence of liquid water and had 6 months' rest period in nature. Seeds of the tropical species were surrounded by fruits bearing little mucilage, germinated in darkness although somewhat favored by

light, needed liquid water for germination and had no rest period. They germinated in 2 to 5 days, except for *L. pentandrus* which required a few weeks for germination because of slow mobilization of food reserves. The germination characters of these seeds showed natural adaptations to their habitats. Their behavior seemed to be determined by ecological conditions rather than by phylogenetic relations.

Wiesner thought that the 6 months' rest in nature necessary for the germination of *Viscum album* seeds was due to slow mobilization of reserves, need of light of considerable intensity, and presence of inhibiting substances in the fruits. In 1897 he found that the rest period of some of the seeds could be greatly shortened, even to 1 month, by using optimum conditions: temperatures of 15° to 20°C., good light, and dry air. Immature seeds germinated more quickly than ripe ones.

Contrary to his earlier claims, Wiesner (106) found that *Loranthus europaeus* seeds germinated in darkness, although they were favored in speed and percentage germination by light. This result was later confirmed by Kinzel (51, Suppl. II, page 67) and Mayr (72). *Loranthus europaeus* seeds had a shorter rest period than *Viscum album*. The immature seeds of this species also germinated more promptly than mature ones.

With a few exceptions Heinricher (36, 37, 39, 40) confirmed Wiesner's conclusions on germination conditions for *Viscum album* seeds. His exceptions were the following: Germination in the open was found to occur during a warm period in February rather than being delayed until April. Germination in the greenhouse was 100 per cent by February 12 in contrast to 10 per cent reported by Wiesner. This result Heinricher attributed to the excellent light in his new greenhouses. He germinated *Viscum album* seeds in contact with liquid water at high temperatures by maintaining the seeds in sterile condition. He claimed that the fruit mucilage hindered germination because it limited the oxygen and water supply to the embryo, rather than because of an inhibiting chemical within the mucilage. He found the minimum temperature for germination to be about 3.8°C. rather than the 8° to 10°C. reported by Wiesner. Heinricher also added some interesting facts not found by Wiesner. The less refrangible half of the visible spectrum favored germination, but the more refrangible half was not effective. A substratum of nutrient gelatin did not favor germination in light or cause germination in darkness. Kinzel (51, pages 16 and 17) found nutrient gelatin ineffective for *Viscum album* and *V. minimum* seeds. This point is of great interest because, as we shall see later, nutrient solutions often substitute for light in light-favored seeds. Kinzel also germinated *V. minimum* in darkness under favorable conditions.

Tubeuf (97) found that germination of the red-berried mistletoe, *Viscum cruciatum*, was greatly favored by light and was slow and incom-

plete in darkness. These seeds germinated in dry air when removed from the fruit and also in the presence of liquid water if protected from bacteria and fungi.

Heinricher (38) found that *Arceuthobium oxycedri*, another epiphytic and parasitic Loranthean, required light for germination. Unlike other parasitic Lorantheae it would not germinate on glass or other inorganic substrata but required a cellulose substratum for germination. Pure Swedish filter paper proved excellent, and spruce wood was good. Heinricher considered this as evidence that *Arceuthobium* was more strictly parasitic than *Viscum* and *Loranthus*. *Arceuthobium oxycedri* seeds could remain longer in darkness without losing their germinating power than *Viscum album* seeds. After 3 months in darkness the seeds still gave 7 per cent germination in light.

Cannon (10) studied *Phoradendron villosum* and *P. californicum*, and Peirce (82) investigated *Arceuthobium occidentale*, but since they were unable to germinate the seeds, we have no information on the effect of light on the germination of American parasitic Lorantheae. Van Tieghem (94) found that the seeds of *Nuytsia floribunda*, a species of Lorantheae which is not an epiphyte but a root parasite, retained their vitality during 2 years of dry storage, and that they would germinate in both light and darkness.

Bessey (6) showed that seeds of the strangling fig, *Ficus aurea*, germinated only in light, but the seeds of *Ficus populnea*, a less strict epiphyte, would germinate in darkness but were favored by light. Seeds of *Ficus carica* (51, page 16) and *Ficus elastica* (90) are also light-favored.

Heinricher (34), who investigated several Bromeliaceae, found light necessary for the germination of seeds of *Pitcairnia maidifolia*, mainly a rock or soil inhabitant. He believed light a requirement for the germination of seeds of most Tillandsiæae, many of which are epiphytic. Other groups of the Bromeliaceae showed different behavior. Germination of seeds of *Dyckia rariflora* and *D. sulphurea* was hastened only slightly by light, and *Aechmea coerulescens* germinated equally well in light and darkness.

While most of the epiphytic parasites or epiphytes mentioned above are favored in their germination by light, and some apparently require light, there is no strict relationship between epiphytism and light requirement. Also no strict uniformity of behavior exists within the same family of plants or even within the smaller more closely related systematic groups, although certain systematic groups seem to have a large proportion of species, the seeds of which are favored by light.

A defect in all of the researches reported in this section is the failure to study the favoring action of light under a sufficient range of other conditions. This fact will become evident when the researches on *Chloris* and *Poa* are discussed.

Gesneriaceae.—Figdor (17, 18) could not germinate seeds of any species of *Gesneriaceae* that he studied except in light. In his first investigation he placed seeds of *Streptocarpus wendlandii*, *S. kirkii*, *S. polyanthus*, *S. rexii*, *S. achimendiflora*, *Naegelia amabilis*, *Saintpaulia ionantha*, and *Sinningia regina* in light and dark germinators. In 10 to 23 days the seeds in light germinated, but there was no germination in dark even after 2 months. Seeds in the dark germinated when transferred to light, some species more and some less promptly than if they had been placed in light germinators immediately. Figdor later obtained similar results with seeds of *Klugia zeylanica*, *Monophyllaea horsfieldii*, *Alloplectus sanguineus*, *Tydaea hybrida* var. *grandiflora*, *T. lindeni*, *Isoloma hirsutum*, *I. hirsutum multiflorum*, *Gesneria aurantiaca*, *G. macrantha*, *Streptocarpus grandis*, *Naegelia zebrina*, and *Gloxinia hybrida erecta grandiflora*. His first investigation was made at 18°C. and the second at 20°C. He did not study the effect of various constant or intermittent temperatures.

According to Lehmann (62, pages 477 and 478), thoroughly after-ripened seeds of *Gloxinia (Sinningia) hybrida* which had been in dry storage for 3½ years still required light for germination. He concluded that after-ripening these seeds did not modify their light sensitiveness. Ottenwälder (81, page 795) could not induce germination of *G. hybrida* seeds in darkness by raising the temperature of the seed bed up to 40°C. or by pricking the seed coats. Gassner (25), however, obtained about 6 per cent germination of *Sinningia speciosa* seeds in darkness on filter paper moistened with distilled water, 43 per cent in darkness on filter paper saturated with 0.01 molecule KNO_3 , and 53 per cent in diffuse light on filter paper wet with distilled water. Ammonium salts, nitrates, and nitric acid in proper concentrations forced the germination of these seeds in darkness, but salts, acids, and bases not containing nitrogen were not effective.

Investigations to date indicate that there is no other plant family in which the seeds are so consistently favored in germination by light as are the seeds of this tropical and subtropical family. The germination of *Gesneriacean* seeds, however, should be studied under many other conditions in conjunction with light.

Chloris ciliata.—No light-favored seeds have had more thorough study than the achenes of the South American pampas grass, *Chloris ciliata*, especially in respect to the effect of other conditions upon their light-sensitiveness.

Gassner (23) found that light acted as such, and not through its heating effects; for no constant temperature would substitute for light, and light was effective even when it did not induce daily intermittent temperatures. Many of the light and dark experiments were carried out at constant temperatures varying not more than 1°C.

Like many other seeds and fruits, the achenes of *Chloris ciliata* gradually after-ripen with dry storage, the process being completed in 8 months (21, 23). Non-after-ripened achenes, at the optimum temperature, 33° to 34°C., required light for germination if they were in the hulls (palea and lemma). The germination in light was not complete, but improved as after-ripening progressed. Completely after-ripened achenes in the hulls gave about 16 per cent germination in darkness at the optimum temperature and about 80 per cent in daylight. Partially after-ripened achenes with the hulls removed were also favored by light; about 55 per cent germinated in darkness at the optimum temperature, and 90 per cent in light. Fully after-ripened achenes with the hulls removed germinated completely both in light and in dark.

Light favored germination (22, 27) only at temperatures above 22°C., was indifferent at or near 22°C., and inhibited germination below this temperature. At 22°C., however, the effect of light was modified by the stage of after-ripening; achenes after-ripened 2 months were favored by light, those after-ripened 5 months were indifferent to light, and those after-ripened 17 months were inhibited by light.

High light intensities (21) were more favorable to germination of *Chloris ciliata* than low intensities, but as after-ripening progressed, the lower limit of intensity required for germination dropped, and the duration of any given light intensity necessary to increase germination fell. Illumination of the achenes with the hulls intact for one or more days followed by continuous darkness favored subsequent germination at the optimum temperature. Since the first day's illumination increased germination much more than the second or later day's, increase in germination was not proportional to the amount of light applied. Diffuse light for 1 to 4 hr. increased later germination in darkness 9 to 19 per cent, and direct sunlight for 2 hr. increased germination 36 per cent.

Achenes with the hulls intact were so sensitive to darkness, especially in the first stages of germination, that Gassner (21) obtained 10 to 16 per cent higher germination with daylight if the achenes were put into the germinator in the morning rather than in the evening. Longer periods in a dark germinator with the hulls intact even at temperatures favorable for germination in light made the achenes "dunkelhart," that is, incapable of later germination in light. Subminimal temperatures, 6° to 10°C., in dark germinators for 16 days did not make *Chloris* achenes "dunkelhart" or injure their germinating power in any way. Three to 11 days in a germinator at 0°C. injured the achenes somewhat and the injury increased with time. Gassner believed this low-temperature injury was due to the tropical nature of the plant. "Dunkelhart" achenes could be forced to prompt germination by application of nitrates, by the use of soil as a substratum (23), or by breaking the fruit

coat over the embryo. In this respect "dunkelhart" achenes of *Chloris* acted like "lichthart" seeds of *Nigella sativa* (46, page 269).

Gassner (27) found that if imbibed light-favored achenes were exposed to an effective dose of light, dried for a long period, and then placed in a dark germinator, the favoring effect of the light still persisted. This latent light effect was easier to demonstrate with *Ranunculus sceleratus* seeds for, while they are modified by light at 28°C. constant, they will germinate in light only at intermittent temperatures. It was demonstrable, nevertheless, with *Chloris* achenes. Gassner believed this latent light effect proved that light did not act as a releasal stimulus but brought about some permanent biochemical change which lasted during a long period of dry storage.

As noted above, after-ripened achenes with hulls removed germinated equally well in light and dark at high temperatures, but if the hulls were intact, they were greatly favored by light. Achenes with hulls intact germinated readily in darkness in a full atmosphere of oxygen; consequently, Gassner (23) concluded that the hulls lowered the oxygen supply to the embryo and thereby prevented germination. The hulls changed the achenes to light requirers by restricting the oxygen supply. Gassner changed after-ripened achenes with the hulls removed to light requirers by wrapping them tightly in wet filter paper. He concluded that the wet filter paper reduced the supply of oxygen to the achenes. Removing the hulls aided germination at both constant and alternating temperatures.

Daily intermittent temperatures (22) were effective in forcing the germination of after-ripened *Chloris* achenes with hulls intact but had no effect on such achenes with the hulls removed, for the removal of the hulls alone gave good germination. Intermittent temperatures were not effective with non-after-ripened achenes or "dunkelhart" achenes, but their effectiveness rose with the degree of after-ripening of the achenes that were not "dunkelhart." The best daily intermittent temperatures had a large difference between the low and high temperatures with the low-temperature period long in comparison with the high period. The intermittent temperature of 12°C. for 19 hr. daily and 28°C. for 5 hr. was much more effective in forcing germination in darkness than 12°C. for 5 hr. and 28°C. for 19 hr. Gassner believed that daily intermittent temperatures increased the oxygen supply to the embryo, favoring germination by the same means as removal of the hulls. At the low temperature oxygen accumulated in the achene because of its higher solubility at this temperature and because of low respiration. The high temperature with the high oxygen supply favored quick germination.

Gassner (23, 25, 26) found that Knop's solution displaced the need of light for the germination of *Chloris* achenes. It was effective at all temperatures that permitted germination, while light was favorable only at temperatures above 22°C. Table 1 shows the favoring action of

Knop's solution on the germination of partially after-ripened achenes in darkness at various temperatures:

TABLE 1

Temperature, °C.	12	15 to 16	19	24	28	33 to 34
Water, % germinated.....	0	6.5	21	36	59	62
Knop's solution, % germinated....	34	90	98	99	98	98.5

After-ripened achenes with the hulls intact yielded results with water, Knop's solution, and soil, as shown in Table 2.

TABLE 2

Temperature, °C.	19	24	28	33 to 34
Water, % germinated.....	19	17.5	14	14.5
Knop's solution, % germinated.....	89.5	92	85.5	83
Soil, % germinated.....	87	91	81	77.5

Calcium nitrate was the constituent of Knop's solution that forced germination in darkness. The chlorides, sulphates, and phosphates had no effect on germination except an injurious effect at high concentrations. All nitrogen compounds tested (ammonium salts, various nitrates and nitrites, nitric acid, and urea) were effective in forcing *Chloris* achenes in darkness and Gassner believed the stimulating action of soil was due to the soluble nitrogen compounds it contained. The best concentration of KNO_3 was about 0.05 mol., and of HNO_3 between 0.001 and 0.01 mol. The minimum effective concentration of the N compounds ranged from 0.001 to 0.0001 mol.

Nitrogen compounds favored the germination of light-favored seeds of *Ranunculus sceleratus* and *Oenothera biennis* in darkness if certain other conditions were supplied. According to Gassner, acids do not substitute for light in these seeds, although they do in *Epilobium hirsutum* (68) and some others. Gassner spoke of two classes of light-favored seeds: those in which nitrogen compounds replaced light and those in which acids replaced light.

Gassner (27) studied the permeability of the coats of *Chloris ciliata* achenes to iodine and KNO_3 . Iodine in water solution entered the coats rather readily, the coats at the embryo end being more permeable than at the distal end. On the other hand, KNO_3 in water solution did not pass through the intact coats of the achene at all. The experiment showed that nitrates substituted for light as a germination promoter without actually entering the living part of the achene. This fact was important to Gassner in shaping his explanation of the mechanics by which light and darkness modify the germination of *Chloris* achenes.

Because of the latent effect of light on *Chloris* achenes and *Ranunculus* seeds, and because of the failure of the Fechner law to apply, Gassner believed that light did not act as a releasal process or stimulus in the sense of Pfeffer or Jost. He also considered untenable Lehmann and Ottenwalder's conception that light had a direct or indirect catalytic effect on the seed, thereby increasing the mobilization of reserve materials. The catalytic conception would not explain the effectiveness of nitrates without their entering the achenes, or the production of a "dunkelhart" condition in the dark germinator. Gassner thought that unfavorable conditions in the germinator brought about a change in the achene coats which prevented later germination even under favorable conditions. He spoke of this as the "Hemmungsprinzip." Any condition causing quick germination did not give the change in the coats time to occur. Among these conditions were high light intensity along with high temperature, absence of the hulls, high partial oxygen pressure, nitrogen compounds in the substratum, and suitable intermittent temperatures.

In his work Gassner did not explain how light overcame the limited oxygen supply caused by the hulls. Aside from a change in color he did not define any change in the coats produced during a period in the dark germinator. He failed to determine whether the embryo was modified by the period in the dark germinator so that it became incapable of later overcoming the resistance of the coat to germination. Changes occurring in both the coats and embryos during the period in the dark germinators were possible to investigate and should have been investigated. Davis (15) showed that embryos of *Xanthium* seeds with coats intact could be thrown into a partially dormant state by certain unfavorable conditions in the germinator. The partially dormant embryos would not grow when the coats were intact even under favorable conditions, and grew very tardily when the coats were removed. Davis (14) obtained similar but more striking effects with naturally dormant but after-ripened embryos of *Ambrosia* when they were placed in a germinator with the coats intact at 28°C. or above. In both of these seeds high oxygen pressure forced germination if the embryos were not dormant, and the seed coats were intact.

Gassner (21, pages 364, 504 to 512) studied the effect of light and other conditions upon the germination of the achenes of three other grasses of the pampas. The germination of *Chloris distichophylla* was favored by light, and the germination was improved in both light and dark by after-ripening in dry storage. The optimum temperature for germination was between 35° and 40°C., the minimum about 25°C., and the maximum 45°C. *Chloris distichophylla* achenes were not so sensitive to a dark germinator as those of *Chloris ciliata*. *Stenotaphrum glabrum* achenes were favored only slightly by light. Like all the pampas grasses mentioned in this section, they are attuned to high temperatures: minimum

20°C., optimum between 30° and 37°C., and maximum 40°C. Unlike the other pampas grasses mentioned, the germination of achenes of *Paspalum dilatatum* was not favored by light, but was improved by a period in a low-temperature germinator followed by a constant high temperature. They were after-ripened in dry storage, and the speed of after-ripening was increased by drying for several days at 55°C.

The diverse germination behavior of achenes of these four species of pampas grasses growing in identical habitats indicates that no strict relation exists between the habitat of a plant and its need of light for germination.

Poa.—In 1878 Wagner (55) found that light had a marked stimulating effect on germination of *Poa* achenes. Stebler (92) confirmed and extended his results. Nobbe (80) obtained slightly lower germination of *Poa* achenes in light than in darkness. Because of the importance of the blue grasses in pastures and lawns the effect of light upon germination of these achenes has received the attention of many later investigators. Results are not in agreement, largely because other factors modifying light sensitiveness were not fully investigated, but all workers since Nobbe have agreed that under certain conditions light favors the germination of *Poa* achenes.

Jönsson (45) was the first to show that the need of light for germination fell as the seeds after-ripened in dry storage. In tests at various dates beginning October 1, 1891, dry-stored *Poa pratensis* achenes in light and dark at 20°C. gave the following percentage germination:

TABLE 3

Date	Germinated, per cent	
	Light	Dark
Oct. 1, 1891	88	1
Nov. 12, 1891	85	7
Jan. 3, 1892	87	11
Mar. 30, 1892	89	39
May 21, 1892	82	44
June 8, 1892	85	67
Sept. 9, 1892	80	78

Jönsson received similar results with *Poa trivialis* achenes.

Reiling (87) confirmed Jönsson's results and showed that the degree of maturity of the achenes at time of harvest as well as the duration of dry storage determined their germination capacity at 20°C. in darkness. Pickholz (84) found that the percentage germination was inversely proportional to the water content of the achenes during storage. Hite (44) and Maier (71) also confirmed Jönsson's results on the effect of after-

ripening on the light requirement of *Poa* achenes. Maier maintained, however, that although fully after-ripened achenes could germinate completely without light, they were even more sensitive to light than non-after-ripened achenes, for a dosage of light too small to favor the germination of non-after-ripened achenes hastened the germination of after-ripened achenes.

According to Gassner (28) germination of *Poa* achenes was favored by daily intermittent temperatures whether the hulls were intact or removed. Maier (71) found that light favored germination of achenes with hulls intact or removed, but that removal of the hulls increased germination and light sensitivity of the achenes. Andersen (1) got considerably higher germination both in light and darkness when the hulls were removed and the achenes were moistened with water and germinated at the intermittent temperature 20° to 30°C. While the hulls of *Poa* modify somewhat the light sensitiveness and germination of the achenes, they play no such an important role as do the hulls of *Chloris*.

Nitrogen compounds have been shown to favor the germination of *Poa* achenes to a marked degree. With many samples of *Poa compressa*, Toole (95, 96) obtained complete germination of the achenes only when intermittent temperatures were supplemented by exposures to light and to a 0.2 per cent KNO_3 solution. Nelson (73) found that next to intermittent temperatures KNO_3 was most effective in forcing germination of *Poa* achenes. Potassium nitrate, NaNO_3 , and $\text{Ca}(\text{NO}_3)_2$ were effective in the order named. Germination was depressed by 0.1 and 0.01 per cent $\text{Pb}(\text{NO}_3)_2$, also by NaNO_2 and KNO_2 , but NH_4NO_3 was as effective as KNO_3 . The nitrogen compounds most effective on filter paper were least effective in the soil. $\text{Pb}(\text{NO}_3)_2$ and $\text{Pb}(\text{NO}_2)_2$ were very effective in soil. Hite (43) and Maier (71) also found nitrates favorable to the germination of *Poa* achenes. Andersen (1) germinated achenes of *Poa pratensis* in light and darkness at daily intermittent temperatures (18 hr. at 20°C. and 6 hr. at 30°C.), wetting some achenes with water and others with N/50 KNO_3 . Her results were as follows:

TABLE 4

Condition	Germination percentages	
	With water	With KNO_3
Light.....	60 to 70	90 to 95
Darkness.....	20 to 30	80 to 85

Increased partial oxygen pressures (28) did not increase germination of *Poa*. Germination hastened and increased germination (77), especially

if accompanied by intermittent temperatures and light. Maier (71) found acids favorable. There has been considerable disagreement about the best substratum to use in combination with intermittent temperatures, light, or nitrates in testing *Poa* achenes. Pieper (85) found blotting paper or sand with 60 per cent moisture capacity best for *Poa pratensis*. Laschke (59) used clay, sand, or wood felt with more success than blotters. Kling (53) recommended clay pots rather than Petri dishes or blotting paper. Finally Goss (29) stated that Petri dishes gave consistently low results, while the achenes germinated well on or between blotters.

All investigators (9, 28, 43, 45, 52, 69) agreed that *Poa* achenes germinated poorly at constant temperatures, especially in a partly after-ripened condition and in the absence of light, but that proper daily intermittent temperatures were very effective. In fact, some workers (28, 43, 52, 95, 96) considered intermittent temperatures superior to KNO_3 solutions or even light in promoting the germination of achenes of this genus. Toole stated that for complete germination the usual samples of *Poa pratensis* did not require exposure to light or treatment with KNO_3 solution in addition to intermittent temperatures, but that many samples of *Poa compressa* required both of these in addition to intermittent temperatures. Contrary to the results of Toole and Gassner, Maier (71) found that light generally favored the germination of *Poa* achenes in both intermittent and constant temperatures, and that for *P. nemoralis* and some other *Poa* species the effect of light even surpassed that of alternating temperatures. There was considerable disagreement concerning the intermittent temperatures that were most effective. Toole spoke of 20°C. for 18 hr. of the day and 30°C. for 6 hr. of the day as being highly effective. Gassner found that the period at the lower temperature must be much longer than the period at the high temperature. He obtained very good results with long intermittent temperature periods, such as seven days at 12°C. and one day at 24° to 28°C., and he concluded that the low temperature must act about seven times as long as the high temperature to get the maximum effect. This held for many combinations, including daily intermittent temperatures.

Many investigators (31, 32, 46, 84) found direct sunlight far more effective in favoring the germination of *Poa* achenes than diffuse light. This fact no doubt led various workers to believe that the light action was due to intermittent temperatures, the high-temperature periods coming at the time of illumination. Maier's recent work, however, indicated that light as such has some effect, for *Poa nemoralis* achenes were stimulated somewhat by a 1-min. exposure to 200 meter-candles of light, and *P. pratensis* achenes by a few seconds of illumination.

Kinzel (51, pages 6 and 7) studied the effect of different portions of the visible spectrum and of darkness upon the germination of *P. pratensis*

achenes. His results are reported in Table 5. Samples I and III were commercial samples from America. Samples II and IV were collected at Munich; II ripened in sunny weather, and IV in rain. Figures give germinations in one month, except those in parentheses which are for two months. All temperatures were intermittent (20°C. 18 hr. daily and 30°C. 6 hr.) except the one designated, which was constant at 20°C.

TABLE 5

Light condition	I	I (20°)	II	III	IV
Darkness.....	36	0	96	85	92
Light.....	49 (66)	47 (70)	91	97	90
Dark red.....	21 (70)	24 (70)	90	86	86
Orange.....	52 (65)	65 (70)	89	95	93
Yellow.....	12 (63)	13 (61)	92	97	91
Green.....	62 (77)	75 (79)	90	90	87
Bright blue.....	34 (68)	32 (73)	89	57	83
Dark blue.....	0 (62)	0 (65)	88	27	88
Dark violet.....	0 (27)	0 (30)	89	43	83

Darkness gave better germination in samples II and IV than the full visible spectrum and somewhat poorer results in the other two samples. Light was more effective than the red end of the spectrum. Blue and violet rays were very unfavorable in samples I and III even with alternating temperatures, but in samples II and IV the short end of the spectrum showed little decrease in germination. This work again showed the significance of intermittent temperatures and the extent to which they dominate light effects.

Several attempts have been made to explain the mechanism by which light favors germination of *Poa* achenes, but no explanation except the first mentioned below has been supported by enough facts to justify its serious consideration. Much of the effect of direct sunlight doubtless is due to its producing favorable intermittent temperatures, as several authors (31, 32, 46, 84) believed. Diffuse light and artificial light of low intensity increased germination somewhat. It is not likely that they had their effect by producing intermittent temperatures. Reiling (87) suggested that light transformed and activated the reserve materials of the endosperm, but he did not get convincing evidence. Gassner (28) thought that in *Poa* light prevented the development of the "Hemmungsvorgänge," as he believed it did in *Chloris* achenes. Kummer (58) claimed that grass achenes with fats having a low acid number needed light, while achenes with fats having a high acid number germinated in darkness. This held even for seeds of the same species. The various hypotheses offered above for explaining the action of light are worthy of investigation but are by no means established.

It is interesting to compare *Chloris* and *Poa* as to the effect of other factors on the favoring action of light. In both, after-ripening, intermittent temperatures, and N-compounds are effective light substitutes. In both, no proportionality exists between the dosage of light and the extent of its influence upon germination. In *Chloris* the hulls play a major part in the light need, and in *Poa* a rather minor part. High partial oxygen pressures are very effective in forcing *Chloris* achenes in darkness with the hulls intact, but they have no effect on *Poa*. *Chloris* becomes "dunkelhart" in a dark germinator furnishing poor conditions for germination. This apparently is not the case with *Poa*. The coats of *Chloris* achenes are impermeable to KNO_3 in water solution, although it is an effective substitute for light. Adequate data are lacking on the permeability of *Poa* coats.

Although no other grasses have been studied as thoroughly as *Poa* and *Chloris* in respect to the effect of light on germination, many other grasses have received some attention in this regard. Except for the cultivated cereals (*Avena*, *Hordeum*, *Secale*, *Triticum*, and *Zea*), which are indifferent to light, the germination of most grasses is favored by light under some condition or other. The effect of light on germination of grass achenes is reviewed by Lehmann and Aichele (66, pages 432 to 461). Of 56 species reported by them, 36 species were favored by light, 6 species were favored by darkness, mainly after long dry storage, and 22 species, including the cultivated cereals, were indifferent to light. The disagreement between the total number of species mentioned above and the sum of the figures for the three categories is due to the fact that certain species were favored by light under some conditions and indifferent to light or favored by darkness under other conditions.

Ranunculus sceleratus.—Many investigators have shown that the germination of *Ranunculus sceleratus* achenes is greatly favored by light. According to Niethammer (76) 4 months' dry storage modified germination in both light and darkness. Lehmann (60), however, indicated that 10 months' after-ripening was necessary for germination in darkness. Pricking the coats (81) with a pin did not increase germination. The coat effects, however, need a more critical study.

Contrary to Lehmann's early results, Gassner (26) found that light did not force *Ranunculus sceleratus* seeds unless accompanied by intermittent temperatures, and, conversely, that intermittent temperatures were only moderately effective without light. He considered the best daily intermittent temperatures those with large differences between the low and high temperatures and with the long period at the low temperature. There was little germination in darkness at any constant temperature (27), but the intermittent temperatures of 28°C. (4 hr. daily) and 12°C. (20 hr. daily) gave 50.3 per cent germination in darkness and 87 per cent in light; the intermittent temperatures of 28°C. (4 hr. daily)

and 19°C. (20 hr. daily) gave only 60.5 per cent germination in light.

The latent light effect was easily demonstrated with these seeds, since they could be exposed to light at 28°C. without germination. The imbibed seeds were exposed to light for various periods, then dried for 3 to 7 days in darkness, and finally placed in dark germinators at favorable intermittent temperatures. Those that had been in a dark germinator before drying gave 14 per cent germination, those previously exposed to diffuse daylight, 61 per cent, and those previously exposed to continuous artificial light of 600 N. K.¹ intensity 70 per cent germination. The effect was shown even after a week's drying. Gassner concluded that light did not act as a releasing stimulus on this seed, but that it caused biochemical changes which remained effective even after considerable periods of drying.

Lehmann (60), Ottenwälder (81), and Gassner (26) found that dilute HCl and H₂SO₄ did not force *Ranunculus sceleratus* seeds, and Lehmann observed that solutions of H₂O₂ and Fe₂Cl₆ had no action. On the other hand, Lehmann found 1 per cent Knop's solution very favorable to the germination of these achenes in darkness at 20°C.; he got 80 to 92 per cent germination in darkness with Knop's solution, 0 per cent in darkness with water, and 78 per cent in light with water. Knop's solution was not effective at 15°C. Gassner (26) later found Knop's solution very effective in darkness both above and below 20°C., especially when favorable intermittent temperatures were used. Gassner showed that the favorable action of Knop's solution was due to its nitrate content and that other salts of the solution were without influence. Various other nitrogen compounds (nitrates, nitrites, ammonium salts, nitric acid, and urea) were effective also. Lehmann (60) concluded that the action of soils in forcing germination in darkness was due to the soluble nitrogen compounds present.

Onagraceae.—Kinzel (51, page 46) stated that seeds of the family Onagraceae were light-favored. Considerable work has been done on several species of *Epilobium* and some work on *Oenothera*. Kinzel found that alpine species of *Epilobium* were slow to germinate. One lot of *E. trigonum* seeds (50) gave 100 per cent germination in light in 4 months and 53 per cent in darkness in 11 months. In another lot (51, page 46) germination was completed in light after 6 months and in darkness after 18 months. Niethammer (75) found seeds of *E. parviflorum* light-obligates, even after 6 months of dry storage. Fresh seeds

¹ The German authors cited in this paper have used three different light units: Normal German candle, N. K.; Hefner candle, H. K.; and Meter candle, M. K. The values of these in international foot-candles are: N. K. = 1.11 international foot-candles; H. K. = 0.9 international foot-candle; and M. K. = 0.0926 international foot-candle.

of *E. angustifolium* gave some germination in darkness and good germination in light, while seeds stored dry for 6 months germinated equally well in light and dark. According to Lehmann (63), properly after-ripened *E. hirsutum* germinated well in darkness at 20° to 25°C. In Axentieff's (3) experiments seeds of *E. hirsutum* at 14° to 18.5°C. germinated equally well in light and darkness if the coats were pricked with a pin to admit sufficient oxygen. Pricking the coats improved germination even in light. According to Bihlmeier (7) soaking *E. hirsutum* seeds more than 8 hr. reduced their light sensitiveness, but this effect was overcome by increasing the period of illumination.

Both Lehmann (61) and Gassner (24) found that high constant temperatures favored the germination of *E. hirsutum* in darkness. Fassbender (16), on the other hand, claimed that high constant temperatures had no favoring action in darkness and he found intermittent temperatures effective in displacing the need for light. Gassner showed daily intermittent temperatures to be more favorable than the best constant temperature, especially if the low temperature was used for the long period. Gassner's results with *Epilobium* are given in Table 6.

TABLE 6

Light condition and temperature	Germination percentages	
	<i>E. roseum</i>	<i>E. hirsutum</i>
In diffuse light:		
19°C.	92.5	99.0
28°C.	90.0	98.0
In darkness:		
12°C.	0.5	0
19°C.	29.0	10.0
24°C.	33.5	27.5
28°C.	45.5	82.5
28° (4 hr.) 12° (20 hr.)	88.5	100.0
12° (4 hr.) 28° (20 hr.)	66.5	97.5
28° (4 hr.) 19° (20 hr.)	84.5	100.0
19° (4 hr.) 28° (20 hr.)	61.5	92.5

As is evident from Table 6, daily intermittent temperatures proved highly effective as a substitute for light.

In Fassbender's (16) work dilute HCl had little, if any, effect on seeds of *E. hirsutum* unless combined with daily intermittent temperatures or short exposures to light. Hesse (41) showed that dilute HCl and H₂SO₄ at 22°C. in darkness did not increase the germination of seeds of *E. angustifolium*, *E. roseum*, *E. hirsutum*, or *E. montanum*, but that dilute HNO₃ and other nitrogen compounds favored germination of these seeds under the same conditions. Gassner (25) had previously found N com-

pounds in darkness favorable to the germination of some crops of *Epilobium* and indifferent to others. N compounds evidently are far less effective substitutes for light with the germination of *Epilobium* seeds than with *Ranunculus sceleratus* and *Chloris ciliata* achenes, while acids as such have little action on any of them. Lehmann and Ottenwalder (68) found that dilute solutions of pepsin, papayotin, and asparagin favored germination of *E. hirsutum* seeds in darkness, and Niethammer (74) that dilute acetaldehyde solutions had a slightly stimulative effect on *E. parviflorum* seeds.

Using an Osram lamp as a light source at 25°C., Ottenwalder (81) exposed imbibed *E. hirsutum* seeds to light and then placed them in darkness (see Table 7).

TABLE 7

Light intensity	Germination percentages		
	96 hr. exposure	72 hr.	48 hr.
70 H. K. light.....	59	49	30.5
150 H. K. light.....	66	61.5	38.5
300 H. K. light.....	81.5	74	50

Germination rose as the intensity and duration of illumination increased. Even light of 1_{400} H. K. for 95 hr. increased germination noticeably. The higher the constant temperature, the less light was needed to force germination. Fassbender (16) also found that the effectiveness of light increased with the intensity, and that a period in a dark germinator induced a "dunkelhart" condition.

According to Kinzel, seeds of species of *Epilobium* proved to be light-obligates at low temperatures and in the non-after-ripened condition. He (49) showed that white light and the less refrangible half of the spectrum were very effective in forcing the germination of *E. angustifolium*, but that blue light was less favorable than darkness. In *E. roseum* blue light was superior to darkness.

Lehmann (63) concluded that since proteolytic enzymes, acids, light, and high temperatures acted on *Epilobium* seeds in the same way, they must induce hydrolysis of storage proteins, and their action must be catalytic. This conclusion, however, is merely hypothetical, for Lehmann did not show that the proteolytic enzymes actually entered the seeds or that the other effective agents increased the hydrolysis of proteins.

According to Kinzel (51, Suppl. I, page 48) *Oenothera biennis* seeds gathered either half-ripe or ripe gave 100 per cent germination in light after 9 months at 20°C. and no germination in darkness. Ripe seeds of *O. muricata* (51, Suppl. II, page 39) behaved similarly. Takiguti (93)

showed that the germination of *O. odorata* and *O. biennis* seeds was greatly accelerated by light, but that with dry storage of 7 months or longer the germination of *O. odorata* improved in darkness.

In *Oenothera biennis*, *O. lamarckiana*, *O. suaveolens*, *O. muricata*, *O. cockerelli*, and *O. sylvicola* (3, 81, 98) the seed coats interfered with water absorption. This interference was partially overcome, and germination was increased considerably by pricking the coats with a pin or subjecting the seeds to a water pressure of 8 atmospheres for 3 days.

Gassner (26) considered Kinzel's failure to get germination in darkness due to the low temperatures used. He germinated *O. biennis* at various constant and daily intermittent temperatures with results given in Table 8.

TABLE 8

Temperature	Percentage germination	
	Light	Dark
12°C.	0
19°C.	15.5	0.5
24°C.	25
28°C.	91.5	65
12° (20 hr.) 28° (4 hr.)	24.5
12° (4 hr.) 28° (20 hr.)	90

The combination of 19° and 28°C. was not so good as the combination of 12° and 28°C. Takiguti found that *O. odorata* seeds germinated well in darkness in daily intermittent temperatures, and that immature seeds germinated well in dark at about 10°C. and in diffuse light at about 20°C.

Ottenwälder obtained 22 per cent germination of *O. biennis* seeds in darkness using 0.006 mol. HCl and none without acid. Gassner got increased germination of these seeds with solutions of N compounds combined with intermittent temperatures although the most effective intermittent temperature gave maximum germination without N compounds. Takiguti found that KNO₃ solutions stimulated the germination of *O. odorata* in darkness.

Lythrum.—According to Kinzel (51, Suppl. I, page 25) *Lythrum salicaria* seeds in a germinator at 20°C. for a period of four years gave 100 per cent germination in light and none in darkness. *L. hyssopifolia* seeds gave 17 per cent germination in both light and darkness within a few weeks and no further germination except in light. In a later test of Kinzel's (51, Suppl. II, page 118) *L. hyssopifolia* seed in an illuminated germinator for 2½ years germinated gradually to 92 per cent. The slow germination in light, and the failure to germinate in darkness were no doubt due to the low temperature used.

Lehmann (64) found that exposure of imbibed *Lythrum salicaria* seeds to 730 H. K. of light for 0.1 sec. at 30°C. gave 50 per cent germination in 24 hr., against 6 to 7 per cent without the exposure after 10 days. Lehmann (65) and Lehmann and Lakshmana (67) showed that a relation existed between the germination and the product of light intensity and time of the exposure. This law applied fully at 31°C. with intensities of 5, 50, and 100 M. K., but there was considerable deviation with lower temperatures or higher intensities of light. The deviations from the law were even greater when temperatures of 25°C. or lower and high light intensities were combined. Within limits the Talbot law also applied, although in cases where the dark periods between exposures were long, the individual periods of illumination proved excessively effective.

Lehmann concluded that since these two laws applied, the action of light was upon the protoplasm. One must remember, however, that the product law applied only within narrow limits, and the Talbot law showed one limitation. In *Chloris* Gassner thought that light acted on the coat, while Wieser believed both effects possible. It may be that for some seeds the action of light is upon the coats, for others upon the protoplasm, and for still others upon both the coats and protoplasm.

Wieser (102) found that different samples of *L. salicaria* seeds varied greatly in their need of light for germination, and that only imbibed seeds were affected by light. He also observed the latent light effect in these seeds, as Gassner had in *Chloris* and *Ranunculus* achenes. He concluded that the variation in light need shown by different samples of seeds might be due to the variation in the amount of light exposure the seeds received during ripening in the capsules previous to drying out.

Various investigators (16, 25, 41, 65, 68, 81, 101) agreed that weak acid solutions favored the germination of *L. salicaria* seeds in darkness, especially if combined with moderately effective intermittent temperatures. Gassner grouped *Lythrum* with the acid-type of light-favored seeds. Nitrogen compounds (41, 81) increased germination in darkness. Increased partial oxygen pressure (8, 102) did not increase the germination in light. Wieser found that light forced germination only during normal respiration and not during intramolecular respiration.

Other Seeds Favored by Light.—The sections above cover the light-favored seeds that have been studied in greater detail. There are a number of other seeds that have received considerable attention, but their consideration will not add anything in fact or principle that will further an understanding of the subject. It might be well, however, to summarize briefly the extensive work of Kinzel (51). He studied seeds or fruits of 964 species of plants as to their sensitiveness to light. He used rather low temperatures, 17° to 20°C., and did not try most of the conditions that other investigators found effective as substitutes for light. Because of the restricted conditions under which he made these studies

there is no doubt he has classified many seeds as requiring or being favored by light that under other conditions would germinate perfectly without light. Of the 964 sorts tested, 343 required light or were favored by light, 128 were favored by darkness, 271 responded to light and severe frost ($-20^{\circ}\text{C}.$), 95 to darkness and severe frost, 58 required light and mild frost (-2° to $2^{\circ}\text{C}.$), 34 darkness and mild frost, and 35 were indifferent. Of the 964 sorts used, 69.7 per cent were light-favored, 26.6 per cent dark-favored, and 3.5 per cent indifferent.

SEEDS THAT ARE INHIBITED BY LIGHT

Phacelia tanacetifolia.—As previously mentioned, *Phacelia tanacetifolia* seeds were amongst the first investigated (88) in which germination was hindered by light. These seeds have been more studied than any other light-inhibited seeds as to their light sensitiveness and the effect of other factors upon their light sensitiveness and germination. All the authors cited in this section agree that light reduced the speed and total germination of the intact seeds, and that the inhibiting effect increased with rise in light intensity.

The investigators usually worked with daylight, which meant large variation of light intensity and exposure of the seeds to darkness every night. The darkness, of course, favored germination. Remer (88), who first studied the effect of light on *Phacelia tanacetifolia* seeds, found that direct sunlight greatly hindered germination and that the inhibition lessened as the light intensity decreased. Magnus (70), using 1-year-old seeds, obtained 90 per cent germination in darkness, 4 per cent at a north window, and 40 per cent 1 meter from a north window.

Kuhn (56) and Nikolić (78) employed constant and continuous artificial light sources. In Kuhn's experiment light with intensities of 380, 133, 84, and 64 N. K. produced "lichthart" seeds in a few days; that is, so changed the seeds that they would not germinate later in darkness. With an intensity of 40 N. K., 28 per cent germinated in 4 days and the rest became "lichthart," while 68 per cent germinated in the same time in darkness. Nikolić showed that the inhibition increased with light intensity following a hyperbolic curve. A constant light of 0.8 H. K. intensity decreased germination 30 per cent. Previous exposure of the seeds to light inhibited germination in darkness, the degree of inhibition increasing with the duration of exposure and intensity of the light; likewise, a period in a dark germinator before illumination reduced the inhibiting action of light, the effect increasing with length of the dark period.

The region of the visible spectrum that hinders germination of *Phacelia tanacetifolia* seeds has had some attention. According to Heinricher (35) germination was hindered by white light and the less refrangible half of the spectrum, and favored by darkness and the more refrangible half.

Remer (88) and Kinzel (48, 50) found green the most favorable portion of the spectrum for germination. Kinzel reported 10 per cent germination in white light, 55 per cent in darkness, and 93 per cent in green light. Heinricher (35) suggested without any experimental evidence that the inhibiting effect of light on the germination of *Phacelia* seeds might be due to the fact that white light or the first half of the spectrum reduced the acidity, as in succulents, giving a less favorable medium for lipase activity. He also suggested that light might even destroy the lipase.

After-ripening *Phacelia* seeds in dry storage modified their germination in both light and darkness. According to Heinricher (35) freshly harvested seeds did not germinate in light and only moderately in darkness. After 2 months of dry storage there was 4 per cent germination in light, and good germination in darkness. Dry storage in direct sunlight or in darkness was equally beneficial. Kuhn (56) found that seeds stored 6 years in darkness gave 100 per cent germination in darkness against 61 to 92 per cent for new seeds. Seeds stored for 4 years in light followed by 2 years in darkness gave only 64 to 80 per cent germination. Age also modified the behavior toward various portions of the spectrum.

Remer (88) found 5°C. the minimum temperature for the germination of *Phacelia* seeds in darkness. Good germination was obtained at 6° to 7°C. For germination in light the minimum temperature was 10°C., and the optimum 15°C. A temperature of 20°C. or above was unfavorable. Rijof (89) got 90 per cent germination in darkness in 10 days at 14° to 16°C. and 64 per cent at 20°C.

Increased partial oxygen pressure favored germination in light. In 75 per cent O₂ Axentieff (3) obtained 73 per cent germination in light and 86 per cent in darkness. In high oxygen pressure many of the seeds germinated backward; that is, the cotyledons grew first. This backward germination was similar to that obtained by Crocker (13, page 272) for the upper achenes of *Xanthium*, the coats of which restrict the oxygen supply to the embryos. Böhmer (8) claimed that the light-inhibited seeds of *Nigella sativa* and *Phacelia tanacetifolia* germinated much better in light in 80 to 100 per cent oxygen than in air, that the light-favored seeds of *Epilobium hirsutum*, *Nicotiana tabacum*, *Lythrum salicaria*, and *Elsholtzia* germinated better in normal than in increased oxygen pressures; and that light-indifferent seeds were not affected by increased partial oxygen pressures. Böhmer was certainly incorrect about light-indifferent seeds, for Crocker (13) found the germination of the intact upper achenes of *Xanthium* was increased by high partial oxygen pressures. Axentieff (3) and Gassner (23) have found also that high oxygen pressures increased the germination of various light-favored seed.

Kuhn (57) investigated the effect of acid on germination of *Phacelia*, using filter paper moistened with solutions of various concentrations. Seeds in light gave 69 per cent germination in 0.1 M HCl and 18 per cent

in distilled water; in darkness they gave 80 per cent germination in distilled water. Acids lowered germination in darkness and stimulated it in light. HCl, HNO₃, and H₂SO₄ had similar effects in like concentrations. According to Magnus (70) acid treatment caused "false germination"; that is, the embryos broke through the coats without growth.

Magnus rinsed from intact seeds of *Phacelia tanacetifolia* a substance which when applied to the same sort of seeds inhibited their growth in weak light, but not in darkness. This substance was fluorescent, heat-stable, water-soluble, and alcohol-insoluble. He pointed out the fact that low concentrations of fluorescent substances are toxic to organisms in light, owing to their photochemical effects. Since darkening the chalazal end of intact seeds or removing the coats from that region permitted germination, Magnus concluded that the fluorescent inhibiting substance was largely located in the chalazal end of the coat. He also obtained from the radicle of *Phacelia* and the leaves of *Pelargonium* a water extract that inhibited germination of *Phacelia* seeds in light but not in darkness. A water extract from *Epilobium* seeds showed no inhibiting effect.

Peters (83) largely confirmed Magnus' results except in two respects. Peters found that the substance inhibited the germination of *Phacelia* seeds slightly, even in darkness, if the washings were first exposed to light, and that the effective agent was not identical with the dark-brown water extract obtained from the coats but was a whitish opalescent material. He considered the joint effect of light and the fluorescent pigment on the germination of *Phacelia* seeds as photocatalytic, while Magnus was uncertain about how they acted. Axentieff (2, 3, 4) studied the effect of the rinsings from several sorts of light-favored and light-inhibited seeds on the germination of the same or other species. His results were quite varied. Some extracts inhibited germination in both light and darkness; others stimulated germination in some seeds and inhibited it in others; and in one case the extract causing inhibition was not fluorescent. Axentieff also found that proper abrasion of the coats would induce perfect germination of *Phacelia* seeds in light and darkness. Abraded seeds gave 98.8 per cent germination in light and 98 per cent in darkness, and intact seeds gave 31.8 per cent in light and 92 per cent in darkness. Böhmer (8) showed that on removal of the coat over the radicle the seeds grew normally, with the root emerging first, in both light and darkness. On removal of the coat at the other end, the epicotyl grew first, and the seed germinated equally well in light and darkness. Removal of a portion of the coat on the sides of the seed did not induce germination in light. The naked embryos germinated equally well in light and darkness.

The work of Axentieff and Böhmer threw some doubt upon the conclusions of Magnus and of Peters that light inhibition of *Phacelia* was a photocatalytic action. They showed that the seed coats of *Phacelia*

limited the oxygen supply to the embryo. This limitation could be partially or entirely removed by increased oxygen pressure or removal of the seed coats. Axentieff (3) pointed out that light interfered with oxidation processes in some plants and stimulated it in others; he suggested that *Phacelia* and other light-inhibited seeds might be prevented from germination by the joint action of the coats, which restrict the oxygen supply to the seed contents, and light, which interferes with oxidation processes within the seeds.

Lehmann (62) believed that light inhibition generally characterized seeds of the Hydrophyllaceae since *Nemophila insignis* and its relatives *Phacelia tanacetifolia*, *P. whillavia*, and *P. campanularia* all were hindered by light. On the other hand, Kuhn (56) showed that the seeds of *Hydrolea spinosa* were favored by light. No strict relationship usually exists between systematic grouping and light-sensitiveness.

Nigella.—Kinzel (46) showed that at 20°C. seeds of *Nigella sativa* were hindered in germination by light, and that they became "lichthart" with only 24 hr. exposure. "Lichthart" seeds were incapable of later germination without special treatment. Although light lowered the germination at 10° to 15°C., it did not make the seeds "lichthart." Seeds which had become "lichthart" could be forced to germinate in part by pricking the coats or by using daily intermittent temperatures of 20° to 30°C. The best way to force "lichthart" seeds was to dry them over CaCl₂ for 24 hr. at 30°C., soak in 1 per cent asparagin and 0.1 per cent papayotin solution for 5 days, prick with a pin, and then after 24 hr. swelling put to germinate at alternating temperatures of 20° to 30°C. Seeds which had been in a light germinator 7 months germinated within 14 days after this treatment. *Nigella damascena* was more sensitive to light than *Nigella sativa*. According to Kinzel (48) all portions of the visible spectrum inhibited germination of *Nigella* except green and green-blue, which gave about the same germination as darkness. The habitat in which the seed developed and the stage of after-ripening (51, pages 21 and 22) modified both the percentage germination and the degree of sensitiveness to light.

Lehmann (60) agreed with Kinzel that light rendered *Nigella* seeds "lichthart," but he claimed that an exposure of 3 days or more was necessary for any marked effect, and that much longer exposures were required for greatest effectiveness. Niethammer (76) found *N. damascena* seeds light-avoiding at all temperatures, old seeds being less so than fresh ones. According to Axentieff (3) the inhibiting action of light on *N. arvensis* seeds was not entirely dependent upon the integrity of the coats. Böhmer (8) found that under light of 20 M. K. intensity germination of *N. sativa* seeds increased somewhat as the oxygen pressure rose, and that 100 per cent oxygen was very favorable for forcing germination

under such illumination. Gassner (25) showed that N compounds were without effect in forcing the germination of *N. sativa* seeds.

Liliaceae.—Kinzel (46, 47, 48, 50, 51) claimed that many seeds of the family Liliaceae were favored in germination by darkness. Of the genus *Allium*, seeds of the following species were favored by darkness: *Allium ascalonicum*, *A. cepa*, *A. moly*, *A. porrum*, *A. schoenoprasum*, *A. ursinum*, and *A. victorialis* and the seeds of *A. sibiricum* and *A. suaveolens* were favored by light. Other dark-favored liliaceous seeds which Kinzel investigated were: *Aloë variegata*, *Anthericum liliago*, *A. ramosum*, *Asparagus officinalis*, *Asphodelus ramosus*, *Eremurus robustus*, *Fritillaria imperialis*, *F. armena*, *Funkia coerulea*, *F. sieboldiana*, *Lilium martagon*, *Maianthemum bifolium*, *Medeola asparagoides*, *Paris quadrifolia*, *Polygonatum officinale*, *Ruscus aculeatus*, *Streptopus amplexifolius*, *Tulipa gesneriana*, *Urginea scilla* (dried 2 weeks), *Veratrum nigrum*, and *Yucca aloifolia*. Other light-favored liliaceous seeds were: *Colchicum autumnale*, *Convallaria majalis*, *Lloydia serotina*, *Nartheccium ossifragum*, *Paradisea liliastrum*, *Smilax aspera*, *Tofieldia calyculata*, *Urginea scilla* (fresh), and *Uvularia grandiflora*. *Polygonatum verticillatum* and *Hyacinthus candicans* proved indifferent. The tests of seeds of the Liliaceae were made under relatively limited conditions and in some cases only one test was made.

Other Seeds.—Many other seeds are inhibited by light under certain conditions. This was true of *Chloris ciliata* at temperatures below 22°C., while at temperatures above 22°C. light favored germination. Baar (5) found several seeds favored by darkness at low temperatures and by light at high temperatures. *Amaranthus caudatus* seeds were light-inhibited at 5° to 20°C., indifferent at 25° to 30°C., and light-obligates at 35° to 40°C.

EFFECT OF VARIOUS REGIONS OF THE SPECTRUM

Considerable work has been done upon the relative effectiveness of various regions of the spectrum in promoting the germination of light-favored seeds and in lowering the germination of light-inhibited seeds. Before studies in this field can be rationalized, it will be necessary to know whether the effective action of light is upon the coats which are largely nonliving, the living contents of the seeds, or both; or whether all three of these categories are represented in various light-sensitive seeds. Most seed and fruit coats are colored, showing differential absorption of the visible spectrum. If the endosperm and embryo alone are affected by light, only light which passes through the coats and is absorbed by these organs is significant. If the coats alone are affected, only light absorbed by them is significant. If both portions are affected, both the light absorbed by the coats and the light passing through them are significant. Unfortunately, most of the experimenters have not studied the action

of various regions of the spectrum with a view to answering these questions. Some of the experimenters have also shown other defects, such as failure to use equal energy values for different regions of the spectrum, to control temperatures, and to consider the stage of after-ripening of the seeds.

Cieslar (12) found yellow light most effective in forcing germination of grass seeds, while violet light retarded germination. Haack (30) showed that in Scotch pine yellow light was most stimulative with blue far less so, but the latter better than darkness. According to Heinricher (37) the less refrangible portion of the solar spectrum was favorable to germination of *Viscum album* seeds, and the more refrangible portion ineffective or injurious, with no germination occurring in darkness.

Kinzel (46, 47, 48, 49, 50, 51) studied the action of different regions of the spectrum on the germination of several seeds. Among light-favored seeds he found that for *Nicotiana* the optimum region was yellow, orange, or green; for *Allium suaveolens* red and white were best with green and violet less favorable, but better than darkness; for *Drosera capensis* all rays gave high germination, but the energy of germination fell in the following order: white, yellow, orange, red, green, blue, violet; for *Pinguicula vulgaris* red, white, and orange were good; green and bright blue poor; yellow, dark blue, and violet intermediate; and no germination occurred in darkness; for *Epilobium roseum* long rays of the visible spectrum were better than short rays. In general, the germination of light-favored seeds was favored more by the longer visible rays than by the short rays. Among the light-inhibited seeds Kinzel found that for *Silene tartarica* the blue rays of white diffuse light partly prevented germination in light; for *Delphinium elatum* violet was the most injurious; for *Phacelia tanacetifolia* green was better than darkness; for *Asphodelus ramosus* yellow was the best region for germination at both 14° and 20°C., violet was very injurious at 14°C., and favorable at 20°C., and red to orange was toxic at 20°C.; for *Nigella sativa* the following rays injured germination at high temperatures, the injurious effects decreasing in the following order: white, bright violet, orange, red, yellow, dark blue, and dark violet.

Kommerell (54), using accurate photometric methods, studied the effect of equal caloric values of different regions of the visible spectrum upon the germination of the highly light-sensitive seeds of *Nicotiana tabacum* and *Lythrum salicaria*. She found the percentage germination proportional to the ray length of the region falling on the surface of the seed. She also determined by methods which are open to question the absorption of various regions of the spectrum by the seed coats. The coats of both seeds showed high absorption at 5100 Å. After correcting for seed-coat absorption—in doing this she disregarded various irregularities in the coat absorption curves—she concluded that the effectiveness

of the rays actually reaching the protoplasm was proportional to the quanta they carried, and that the rays acted in accordance with the Einstein principle for photochemical reactions. On the basis of these results, Kommerell believed that only light reaching the living portions of the seed was effective and that the action was photochemical. She ran similar experiments on the light-inhibited seeds of *Phacelia tanacetifolia* but found that the low light intensities which forced *Nicotiana* and *Lythrum* seeds did not inhibit *Phacelia* seeds.

Kommerell's methods have opened the way for exact experimentation in this field. The fact that the effectiveness of light falling on the seeds was proportional to the wave-length is certainly significant, but it is doubtful whether her main conclusion is justified by the facts. Einstein's principle was deduced for an ideal, reversible, unimolecular reaction. There is little probability that the effect of light on seeds is so simple. Kommerell's conclusion appears still more questionable when it is recognized that Einstein's principle does not always hold for simple chemical reactions to which it was supposed to apply. In some cases (91, page 332) the photochemical equivalent is less than that demanded by this principle, and in other reactions it is many times greater.

We have yet to learn to what extent light modifies germination by acting upon the seed coats, on the one hand, and upon the protoplasm, on the other, and just how the various rays bring about such modifications.

DOSAGE OF LIGHT REQUIRED

The dosage of light necessary to modify the germination of seeds and fruits varies greatly with different species. It has already been pointed out that *Poa* achenes respond only to high light intensities; in fact, direct sunlight gives optimum results. *Chloris* achenes with hulls intact also require rather high intensities for maximum germination and are more favored by continuous illumination than by alternate light and dark periods. In the use of alternate light and dark periods, it is beneficial to have illumination during the first period because of the readiness with which these achenes become "dunkelhart." *Viscum album* fruits, strict light-obligates, need relatively high light intensities for germination and are killed by continuous darkness. With the light-inhibited seeds of *Phacelia tanacetifolia* a relatively high intensity of light is necessary to give noticeable inhibition, and high intensities must be applied continuously to give fullest inhibition.

On the other hand, some light-favored seeds need only a very small dosage of light to stimulate germination. Raciborski (86) found that 1 hr. exposure of imbibed tobacco seeds to weak diffuse light followed by darkness gave complete germination within 48 hr. The extreme sensitiveness of tobacco seeds to light may account for disputes in the literature as to the need of light for their germination. Exposure of

the seeds to light during examination may have been sufficient to force the germination of the checks in darkness. The species and varieties of tobacco seeds also vary considerably in light sensitiveness. Lehmann (64) showed that an exposure of 0.1 sec. of imbibed *Lythrum salicaria* seeds to 730 H. K. of light at 30°C. gave 50 per cent germination in 24 hr. against 6 to 7 per cent in darkness. Seeds of *Nicotiana tabacum* and *Lythrum salicaria* appear to be the most sensitive to small dosages of light of any seeds studied to date.

This great variation in the light dosage required by light-sensitive seeds suggests the possibility that the mechanics of light action may be different for different seeds.

THEORIES OF LIGHT ACTION

Many of the theories of light action on seeds have already been discussed in connection with the work of the various investigators. The stimulus or releasal theory of Pfeffer and Jost has little support in the present stage of physiological investigation, especially since the findings of Went (100) and his students on "Wuchsstoff" (auxine) have placed phototropism and geotropism, two strongholds of the stimulus conception, upon a chemical basis.

In his early studies of light-favored seeds Cieslar (12) suggested several possible explanations of light action. Since yellow light proved so effective, he thought C assimilation might occur. This is hardly possible because no chlorophyll is present in most seeds favored and because, as Heinricher later (33) showed, yellow light stimulates germination in both the presence and absence of CO₂. He also suggested the possibility of increased osmotic pressure in the tissues, or of mobilization of reserves, the theory which Heinricher (33, 35) later adopted. This conception could be tested experimentally, but it lacks sufficient evidence to date.

Lehmann (62) at first accepted the Pfeffer and Jost releasal theory, but later (63, 68) expressed the view that light acted catalytically, and concluded that hydrolysis of storage proteins was the effective change. His strongest evidence for protein hydrolysis was the fact that soaking various light-favored seeds in proteolytic enzymes substituted for light. He thought acids either activated proteolytic enzymes or gave a more favorable pH for their action. Lehmann's whole theory lacks experimental proof. It is doubtful whether the large molecules of the enzymes pass through the semipermeable membranes of the seed coats. It may be that the proteolytic enzymes furnish nitrogen which acts on the coats, as Gassner found for nitrates.

Pickholz (84), working on *Poa* achenes, concluded that light had its main effect through the production of daily intermittent temperatures. The facts that direct sunlight is more effective than other light sources

and that intermittent temperatures in darkness are more stimulating than light at any constant temperature point to this conclusion for *Poa*. This explanation, however, cannot apply to highly sensitive seeds like *Nicotiana* and *Lythrum*, in which a single small dosage of light induces high germination in darkness.

From his investigations of *Chloris* achenes Gassner (23, 27) expressed the opinion that light and factors substituting for light hindered the gradual development of an inhibiting layer in the achene coats, either directly or by favoring quick germination. The work of many investigators shows that seed and fruit coats play a significant part in the light sensitiveness of several sorts of seeds and fruits and Gassner's finding that nitrates substitute fully for light in *Chloris* achenes without actually entering the living parts of the achenes is very significant. It is possible, however, that light and the several light-substituting factors promote germination in a variety of ways either by acting on various portions of the seeds or fruits or by acting differently on the same organs. A careful chemical, microchemical, and physiological study of several light-sensitive seeds and fruits is needed to learn the effect of light and its substitutes on the hulls, coats, endosperms, or embryos. It would be advantageous to investigate the isolated embryos of light-sensitive seeds and fruits, as Flemion (19, 20) has done for seeds with dormant embryos, to determine whether they are dormant and, if so, how various conditions modify their growth. Gassner's hypothesis raises such definite questions as whether nitrates favor the decomposition of the carbohydrates of the hulls and coats by microorganisms through furnishing a nitrogen supply for the microorganisms; and whether light and light-substituting factors increase the activity of catalase or other enzymes of the embryos, or bring about other changes that further the growth of the embryos.

Kommerell (54) concluded that only the light passing through the seed coats and reaching the protoplasm was effective and that the effect was photochemical. Her theory and the facts and assumptions on which it was based have been discussed already under Effect of Various Regions of the Spectrum.

Axentieff (3) recently offered an explanation of light sensitiveness in seeds which takes into consideration both coat effects and the effect of light upon the protoplasm of the seed contents. In order to determine how generally coats modified light sensitiveness of seeds and fruits, the author studied 8 species that were hindered by light and 4 species that were favored. Of the seeds or fruits inhibited by light the following showed the light-inhibiting effect to be entirely dependent upon the presence and integrity of the coats: *Amaranthus retroflexus*, *Phacelia tanacetifolia*, *Androsace maxima*, and *Bromus squarrosus*; and the following showed that light-inhibiting effect was not entirely due to the coats: *Cucumis melo*, *C. sativus*, *Cucurbita pepo*, and *Nigella arvensis*. In the

light-stimulated seeds the following showed that the light effect was entirely due to the integrity of the coats: *Rumex crispus* and *Epilobium hirsutum*; and the following that the coats played little or no part in the light-favoring action: *Oenothera biennis* and *Silene densiflora*. *Bromus squarrosus*, *Amaranthus retroflexus*, *Androsace maxima*, and *Epilobium hirsutum* germinated quicker and to a higher percentage in both light and darkness when the coats were broken. For the seeds in which the effect of light was conditioned by the integrity of the coats an increase in partial oxygen pressure above the normal atmosphere increased germination and a decrease in partial oxygen pressure considerably below normal completely inhibited germination. The author concluded that in some seeds and fruits light interfered with oxidation processes within the seeds. In others it favored these processes. The combined action of the light and the coats inhibited the germination in the first case by summation of the hindrance to the oxidation processes. In the second case the favoring effect of light counteracted the inhibiting effect of the coats and increased germination. In seeds and fruits in which the coats did not modify the light sensitiveness, Axentieff assumed that light acted directly on the protoplasm reducing the speed of oxidation in light-hindered seeds and increasing it in light-favored seeds. There is considerable experimental evidence for the coat effects postulated by Axentieff, but direct experimental evidence is lacking for the postulated effect of light upon oxidation within the protoplasm.

The mechanism by which light affects germination needs much additional study. It is not impossible that the action of light is upon the coats in some cases, upon the living protoplasm in others, and upon both in still others.

SUMMARY

A. Light favors the germination of a large number of seeds and fruits. Among these are *Viscum album* together with many other Loranthaceae and epiphytes, all Gesneriaceae studied to date, many grasses, various species of *Oenothera* and *Epilobium*, *Ranunculus sceleratus*, *Lythrum salicaria*, and *L. hyssopifolia*. *Viscum album* and *Arceuthobium oxycedri* will not germinate at all without light. The former is killed in darkness within a few weeks, while the latter endures darkness for a longer period. Of 964 species of seeds studied by Kinzel, 672 or about 70 per cent were favored by light under the conditions used in his experiments.

B. Light interferes with the germination of many seeds and fruits. Among these are several species of *Phacelia* and other Hydrophyllaceae, 3 species of *Nigella*, several species of *Allium* and most other Liliaceae. Of 964 species of seeds and fruits tested, Kinzel found 258 inhibited by light under the conditions of his experiments.

C. Some seeds and fruits germinate equally well in light and dark. This is true of the small grains, *Zea mays*, beans, clover, and many other legumes. Of the 964 species investigated by Kinzel, 35 were indifferent to light.

D. Several conditions partly or entirely displace the effect of light in light-sensitive seeds and fruits.

a. After-ripening in dry storage reduces or entirely eliminates the need for light in various light-favored seeds. *Poa* achenes kept in dry storage for one year germinate almost as well in darkness as in light. After-ripening partially eliminates light need in *Chloris*, *Ranunculus*, *Epilobium*, and *Oenothera* achenes or seeds. The inhibiting effect of light on *Phacelia* seeds falls with period of dry storage.

b. Seed or fruit coats, or the hulls of grasses, increase the necessity for light in the germination of some light-favored seeds. The hulls render *Chloris* achenes light-obligate and increase the need for light in *Poa*. Pricking the seed coats of *Oenothera* increases germination in darkness. The coats also modify the action of light on light-inhibited seeds. Removal of the seed coats from *Phacelia* seeds overcomes the inhibiting effect of light. Pricking the coats causes "lichthart" seeds of *Nigella* to germinate in part.

c. A full atmosphere of oxygen forces the light-obligate *Chloris* achenes with hulls intact to full germination in darkness, and the light-inhibited *Phacelia* seeds to full germination in light.

d. Knop's solution substitutes for light in a number of light-favored seeds. The nitrate of the solution is effective. The other salts of the solution are not effective. Nitrites, nitric acid, ammonium salts, and urea are also favorable. Nitrates entirely displace the light need of *Chloris* achenes with hulls intact at temperatures above 22°C. They also increase greatly the germination at temperatures below 22°C., where light inhibits. Nitrates favor the germination of the following light-favored fruits and seeds in darkness: *Poa*, *Ranunculus*, *Epilobium*, *Lythrum*, and the Gesneriaceae. The light-inhibited seeds of *Phacelia* and *Nigella* are not favored by nitrates.

e. Weak acids substitute for light in part in the light-favored seeds of *Lythrum*, *Scrophularia*, *Verbascum*, and *Epilobium*.

f. Either daily intermittent or high constant temperatures substitute for light in various light-favored seeds. The most favorable intermittent temperatures give better germination of *Poa* achenes than light with any constant temperatures. Light and nitrates increase the germination of *Poa compressa* achenes somewhat at the most favorable intermittent temperatures. Intermittent temperatures replace light with after-ripened *Chloris* achenes with hulls intact, but not with non-after-ripened or "dunkelhart" achenes. With seeds of *Epilobium*, *Oenothera*, and others intermittent temperatures substitute fully for light.

E. When light-favored achenes of *Chloris* are kept for a time in a dark germinator, they are changed in a manner that makes them incapable of germination later even in light. Such seeds are said to be "dunkelhart." "Dunkelhart" achenes can be forced to germinate by breaking the coats, increasing oxygen pressures, and other treatments. When light-inhibited seeds of *Nigella* are kept for a time in a light germinator at a temperature above 20°C., they are changed in such a manner that makes them incapable of germination later even in darkness. Kinzel spoke of such seeds as "lichthart." "Lichthart" seeds can be forced to germinate by breaking the coats, or still better by other treatments. Imbibed *Phacelia* seeds also become "lichthart" when exposed to light.

F. If imbibed *Ranunculus sceleratus* seeds are exposed to light, dried, and later placed in a dark germinator with intermittent temperatures, they still show the favorable effect of the light exposure. *Chloris* achenes also show this latent light effect. Since the light exposure of the seeds during ripening in the capsules varies with the weather, the rate of drying of seeds in the capsules, and the position of the capsule on the plant, Wieser concluded that the latent light effect may account in part for the great variation in the amount of light required for the germination of different collections of the same species of light-favored seeds.

G. Several theories have been offered to explain the favoring or inhibiting action of light upon the germination of seeds and fruits. Most of these theories postulate that the action of the light is upon the living endosperm or embryo, but some of them assert that the action is upon the nonliving coats. None of these theories has adequate evidence for even a single species of seeds. It is not improbable that light has its effective action upon the endosperm and embryo of some seeds, upon the coats of others, and upon both in still others. There is need of a very thorough and detailed chemical, microchemical, and physiological study of the effect of light upon the coats and living portions of several light-favored and light-inhibited seeds and fruits. There is also need of a similar study of the changes brought about in seeds and fruits by agents and conditions which substitute for light.

REFERENCES

1. ANDERSEN, ALICE M. The effect of removing the glumes on the germination of seeds of *Poa compressa*. Amer. Jour. Bot. **19**: 835-836. 1932.
2. AXENTIEFF, B. N. Über die Wirkung von Samenauszügen auf das Keimen von Samen. Jour. Soc. Bot. Russie **12**: 291-306. 1928.
3. AXENTIEFF, B. N. Über die Rolle der Schalen von Samen und Früchten, die bei der Keimung auf Licht reagieren. Beih. Bot. Centralbl. Abt. 1. **46**: 119-202. 1929.
4. AXENTIEFF, B. N. Über die Wirkung von Samenextrakt auf das Keimen der Samen. Proc. Internat. Seed Test. Assoc. **2** (11-12): 149. 1930.
5. BAAR, HENRYK. Über den Einfluss des Lichtes auf die Samenkeimung und seine Abhängigkeit von andern Faktoren. Sitzungsber. Akad. Wiss. Wien. Math. Naturwiss. Kl. Abt. 1. **121**: 667-705. 1912.

6. BESSEY, E. A. The Florida strangling figs. Missouri Botan. Gard. Rept. **19**: 25-33. 1908.
7. BÜHLMEIER, META. Der Einfluss der Vorquellung und der Samenschale auf die Keimung lichtbeförderter Samen. Jahrb. Wiss. Bot. **67**: 702-736. 1927.
8. BÖHMER, KARL. Die Bedeutung der Samentteile für die Lichtwirkung und die Wechselbeziehung von Licht und Sauerstoff bei der Keimung lichtempfindlicher Samen. Jahrb. Wiss. Bot. **68**: 549-601. 1928.
9. BROWN, E. Germination of Kentucky blue grass. U. S. Dept. Agric. Office Exp. Sta. Bull. 115. 105-110. 1902.
10. CANNON, W. A. Observations on the germination of *Phoradendron villosum* and *P. californicum*. Bull. Torrey Bot. Club **31**: 435-443. 1904.
11. CASPARY, ROBERT. *Bulliarda aquatica* DC. Schriften K. Physikal.-Ökonom. Ges. Königsberg **1**: 66-91. 1860.
12. CIESLAR, ADOLF. Untersuchungen über den Einfluss des Lichtes auf die Keimung der Samen. Forsch. Gebiet. Agrikulturphysik **6**: 270-295. 1883.
13. CROCKER, W. Rôle of seed coats in delayed germination. Bot. Gaz. **42**: 265-291. 1906.
14. DAVIS, W. E. Primary dormancy, after-ripening, and the development of secondary dormancy in embryos of *Ambrosia trifida*. Amer. Jour. Bot. **17**: 58-76. 1930. (Also in Contr. Boyce Thompson Inst. **2**: 285-303. 1930.)
15. DAVIS, W. E. The development of dormancy in seeds of cocklebur (*Xanthium*). Amer. Jour. Bot. **17**: 77-87. 1930. (Also in Contr. Boyce Thompson Inst. **2**: 304-314. 1930.)
16. FASSBENDER, PAUL. Lichtkeimung und Säuresubstrat. Beih. Bot. Centralbl. **41**: 239-286. 1925.
17. FIGDOR, WILHELM. Über den Einfluss des Lichtes auf die Keimung der Samen einiger Gesneriaceen. Ber. Deut. Botan. Ges. **25**: 582-585. 1907.
18. FIGDOR, WILHELM. Die Beeinflussung der Keimung von Gesneriaceen-Samen durch das Licht. Ber. Deut. Botan. Ges. **30**: 648-653. 1912.
19. FLEMION, FLORENCE. After-ripening, germination, and vitality of seeds of *Sorbus aucuparia* L. Contr. Boyce Thompson Inst. **3**: 413-439. 1931.
20. FLEMION, FLORENCE. Physiological and chemical studies of after-ripening of *Rhodotypos kerrioides* seeds. Contr. Boyce Thompson Inst. **5**: 143-159. 1933.
21. GASSNER, GUSTAV. Ueber Keimungsbedingungen einiger südamerikanischer Gramineensamen. Mitt. I, II. Ber. Deut. Botan. Ges. **28**: 350-364, 504-512. 1910.
22. GASSNER, GUSTAV. Untersuchungen über die Wirkung des Lichtes und des Temperaturwechsels auf die Keimung von *Chloris ciliata*. Jahrb. Hamburg. Wiss. Anstalten **29** (3 Beih.): 1-121. 1911.
23. GASSNER, GUSTAV. Vorläufige Mittelung neuerer Ergebnisse meiner Keimungsuntersuchungen mit *Chloris ciliata*. Ber. Deut. Botan. Ges. **29**: 708-722. 1911.
24. GASSNER, GUSTAV. Altes und Neues zur Frage des Zusammenwirkens von Licht und Temperatur bei der Keimung lichtempfindlicher Samen. Ber. Deut. Botan. Ges. **33**: 203-217. 1915.
25. GASSNER, GUSTAV. Einige neue Fälle von keimungsauslösender Wirkung der Stickstoffverbindungen auf lichtempfindliche Samen. Ber. Deut. Botan. Ges. **33**: 217-232. 1915.
26. GASSNER, GUSTAV. Über die keimungsauslösende Wirkung der Stickstoffsalze auf lichtempfindliche Samen. Jahrb. Wiss. Bot. **55**: 259-342. 1915.
27. GASSNER, GUSTAV. Beiträge zur Frage der Lichtkeimung. Zeitsch. Bot. **7**: 609-661. 1915.

28. GASSNER, GUSTAV. Untersuchungen über die Wirkung von Temperatur und Temperaturkombinationen auf die Keimung von *Poa pratensis* und anderen *Poa*-Arten. Zeitsch. Bot. **23**: 767–838. 1930.
29. GOSS, W. L. The germination of Kentucky blue grass seed in blotters, bell-jars, and Petri dishes. Proc. Assoc. Off. Seed Anal. North Amer. **14/15**: 119–120. 1923.
30. HAACK. Über die Keimung und Bewertung des Kiefernnsamens nach Keimproben. Zeitsch. Forst- und Jagdwesen **38**: 441–475. 1906.
31. HARTLEB, R., und A. STUTZER. Untersuchungen über die Methode der Samenprüfung, insbesondere diejenige der Grassämereien. Jour. Landw. **45**: 43–60. 1897.
32. HEINRICH, M. Einige Erfahrungen bei Keimprüfungen im Jahre 1910/11. Landw. Versuchs-Stat. **78**: 165–178. 1912.
33. HEINRICHER, E. Ein Fall beschleunigender Wirkung des Lichtes auf die Samenkeimung. Ber. Deut. Botan. Ges. **17**: 308–311. 1899.
34. HEINRICHER, E. Notwendigkeit des Lichtes und befördernde Wirkung desselben bei der Samenkeimung. Beih. Bot. Centralbl. **13**: 164–172. 1903.
35. HEINRICHER, E. Die Keimung von *Phacelia tanacetifolia* Benth. und das Licht. Bot. Zeitg. Abt. 1. **67**: 45–66. 1909.
36. HEINRICHER, E. Über Versuche, die Mistel (*Viscum album* L.) auf monocotylen und auf sukkulenten Gewächshauspflanzen zu ziehen. Sitzungsab. Akad. Wiss. Wien Math. Naturwiss. Kl. Abt. 1. **121**: 541–572. 1912.
37. HEINRICHER, E. Samenreife und Samenruhe der Mistel (*Viscum album* L.) und die Umstände, welche die Keimung beeinflussen. Sitzungsab. Akad. Wiss. Wien Math. Naturwiss. Kl. Abt. 1. **121**: 573–613. 1912.
38. HEINRICHER, E. Ueber besondere Keimungsbedingungen, welche die Samen der Zwerg-Mistel *Arceuthobium oxycedri* (DC.) M. Bieb. beanspruchen. Centralbl. Bakt. Abt. 2. **42**: 705–711. 1915.
39. HEINRICHER, E. Über tödende Wirkung des Mistelschleims auf das Zellgewebe von Blättern und Sprossen. Sitzungsab. Akad. Wiss. Wien Math. Naturwiss. Kl. Abt. 1. **126**: 815–836. 1917.
40. HEINRICHER, E. Warum die Samen anderer Pflanzen auf Mistelschleim nicht oder nur schlecht keimen. Anz. Akad. Wiss. Wien Math. Naturwiss. Kl. **54**: 236–238. 1917.
41. HESSE, OTTO. Untersuchungen über die Einwirkung chemischer Stoffe auf die Keimung lichtempfindlicher Samen. Bot. Arch. **5**: 133–171. 1924.
42. HILTNER. Der Einfluss des Lichtes auf die Keimung. Landw. Versuchs-Stat. **71**: 251–252. 1909.
43. HITE, BERTHA C. Forcing the germination of bluegrass. Proc. Assoc. Off. Seed Anal. North Amer. **11**: 53–58. 1919.
44. HITE, BERTHA C. Effect of storage on the germination of bluegrass seed. Proc. Assoc. Off. Seed Anal. North Amer. **14/15**: 97. 1923.
45. JÖNSSON, B. Iakttagelser oefver Ljusets Betydelse foer roens Groning. Handl. K. Fysiograf. Saellskapets **4**: (Saertryck) 47 pp. 1893.
46. KINZEL, WILHELM. Ueber den Einfluss des Lichtes auf die Keimung, "Licht-harte" Samen. Ber. Deut. Botan. Ges. **25**: 269–276. 1907.
47. KINZEL, WILHELM. Die Wirkung des Lichtes auf die Keimung. Ber. Deut. Botan. Ges. **26a**: 105–115. 1908.
48. KINZEL, WILHELM. Lichtkeimung. Einige bestätigende und ergänzende Bemerkungen zu den vorläufigen Mitteilungen von 1907 und 1908. Ber. Deut. Botan. Ges. **26a**: 631–645. 1908.
49. KINZEL, WILHELM. Lichtkeimung. Weitere bestätigende und ergänzende Bemerkungen zu den vorläufigen Mitteilungen von 1907 und 1908. Ber. Deut. Botan. Ges. **26a**: 654–665. 1908.

50. KINZEL, WILHELM. Lichtkeimung. Erläuterungen und Ergänzungen. Ber. Deut. Botan. Ges. **27**: 536–545. 1909.
51. KINZEL, WILHELM. Frost und Licht als beeinflussende Kräfte bei der Samenkeimung. 170 pp., 2 supplements, 1 vol. tables. Ulmer; Stuttgart, 1913–1926.
52. KLEINE, R. Beobachtungen bei Keimversuchen mit Rispengräsern. Grünland **42**: 282–290. 1924.
53. KLING, FRIEDRICH. Beitrag zur Prüfung der Gräserkeimung. Jour. Landw. **63**: 285–343. 1915.
54. KOMMERELL, ELISABETH. Quantitative Versuche über den Einfluss des Lichtes verschiedener Wellenlängen auf die Keimung von Samen. Jahrb. Wiss. Bot. **66**: 461–512. 1927.
55. KRAUS, K. Vierte Versammlung von Vorständen der Samencontrolstationen zu Cassel am 13 September 1878. Landw. Versuchs-Stat. **23**: 405–411. 1879.
56. KUHN, E. Neue Beiträge zur Kenntnis der Keimung von *Phacelia tanacetifolia* Benth. Ber. Deut. Botan. Ges. **33**: 367–373. 1915.
57. KUHN, E. Dunkelkeimer und Substrat. Ber. Deut. Botan. Ges. **34**: 369–386. 1916.
58. KUMMER, HANS. Fett und Fettsäuregehalt bei Gramineensamen in Beziehung zur Lichtdürftigkeit bei der Keimung. Ber. Deut. Botan. Ges. **50**: 300–303. 1932.
59. LASCHKE, W. Einige vergleichende Untersuchungen über den Einfluss des Keimbettes, sowie des Lichtes auf die Keimung verschiedener Sämereien. Landw. Versuchs-Stat. **65**: 295–300. 1907.
60. LEHMANN, ERNST. Zur Keimungsphysiologie und -biologie von *Ranunculus sceleratus* L. und einigen anderen Samen. Ber. Deut. Botan. Ges. **27**: 476–494. 1909.
61. LEHMANN, ERNST. Temperatur und Temperaturwechsel in ihrer Wirkung auf die Keimung lichtempfindlicher Samen. Ber. Deut. Botan. Ges. **29**: 577–589. 1911.
62. LEHMANN, ERNST. Über die Beeinflussung der Keimung lichtempfindlicher Samen durch die Temperatur. Zeitsch. Bot. **4**: 465–529. 1912.
63. LEHMANN, ERNST. Über katalytische Lichtwirkung bei der Samenkeimung. Biochem. Zeitsch. **50**: 388–392. 1913.
64. LEHMANN, ERNST. Über die minimale Belichtungszeit, welche die Keimung der Samen von *Lythrum salicaria* auslöst. Ber. Deut. Botan. Ges. **36**: 157–163. 1918.
65. LEHMANN, ERNST. Keimungsversuche mit Samen von *Lythrum salicaria*. Ber. Deut. Botan. Ges. **42**: (55)–(60). 1924.
66. LEHMANN, ERNST, und FRITZ AICHELE. Keimungsphysiologie der Gräser (Gramineen). 678 pp. Euke; Stuttgart, 1931.
67. LEHMANN, ERNST, und RAO LAKSHMANA. Über die Gültigkeit des Produktgesetzes bei der Lichtkeimung von *Lythrum salicaria*. Ber. Deut. Botan. Ges. **42**: 65–69. 1924.
68. LEHMANN, E., und A. OTTENWÄELDER. Über katalytische Wirkung des Lichtes bei der Keimung lichtempfindlicher Samen. Zeitsch. Bot. **5**: 337–364. 1913.
69. LIEBENBERG, A. VON. Ueber den Einfluss intermittierender Erwärmung auf die Keimung von Samen. Bot. Centralbl. **18**: 21–26. 1884.
70. MAGNUS, WERNER. Hemmungstoffe und falsche Keimung. Ber. Deut. Botan. Ges. **38**: (19)–(26). 1920.
71. MAIER, WILLI. Untersuchungen zur Frage der Lichtwirkung auf die Keimung einiger Poa-Arten. Jahrb. Wiss. Bot. **77**: 321–392. 1932.
72. MAYR, SOROR IMELDA. Ueber die Keimung und erste Entwicklung der Riemenmistel (*Loranthus europaeus* Jacq.). Sitzungsab. Akad. Wiss. Wien Math. Naturwiss. Kl. Abt. 1. **137**: 345–362. 1928.

73. NELSON, ALEXANDER. The germination of *Poa* spp. *Ann. App. Biol.* **14**: 157-174. 1927.
74. NIETHAMMER, ANNELIESE. Der Einfluss von den Reizchemikalien auf die Samenkeimung. II. Mitt. *Jahrb. Wiss. Bot.* **67**: 223-241. 1927.
75. NIETHAMMER, ANNELIESE. Keimungsphysiologische Studien unter Hervorhebung des Lichtkeimungsproblems. *Biochem. Zeitsch.* **185**: 205-215. 1927.
76. NIETHAMMER, ANNELIESE. Stimulationsprobleme im Zusammenhang mit den inneren Faktoren, die die Keimung bedingen. *Beitr. Biol. Pflanzen* **16**: 267-350. 1928.
77. NIETHAMMER, ANNELIESE. Die Beizwirkung von Germisan auf die Keimung einzelner Wiesengräser bei unterschiedlichen Keimtemperaturen. *Zeitsch. Pflanzenkrankh. und Pflanzenschutz* **42**: 364-383. 1932.
78. NIKOLIĆ, MATO. Über den Einfluss des Lichtes auf die Keimung von *Phacelia tanacetifolia*. *Sitzungsb. Akad. Wiss. Wien Math. Naturwiss. Kl. Abt. 1.* **133**: 625-641. 1924.
79. NOBBE, FRIEDRICH. *Handbuch der Samenkunde.* 631 pp. Wiegandt, Hempel & Parey; Berlin, 1876.
80. NOBBE, FRIEDRICH. Übt das Licht einen vorteilhaften Einfluss auf die Keimung der Grassamen? *Landw. Versuchs-Stat.* **27**: 347-355. 1882.
81. OTTENWÄLDER, ALBERT. Lichtintensität und Substrat bei der Lichtkeimung. *Zeitsch. Bot.* **6**: 785-848. 1914.
82. PEIRCE, GEORGE J. The dissemination and germination of *Arcuthobium occidentale*, Eng. *Ann. Bot.* **19**: 99-113. 1905.
83. PETERS, THEODOR. Die Wirkung des Lichtes bei der Keimung der Samen von *Phacelia tanacetifolia*. *Ber. Deut. Botan. Ges.* **42**: 381-387. 1924.
84. PICKHOLZ, L. Ein Beitrag zur Frage über die Wirkung des Lichtes und der internüttierenden Temperatur auf die Keimung von Samen, sowie über die Rolle des Wassergehaltes der Samen bei dieser Wirkung. *Zeitsch. Landw. Versuchsw. Oesterreich* **14**: 124-151. 1911.
85. PIEPER, H. Vergleichende Keimversuche mit Grassamereien nebst einigen Bemerkungen zu grundsätzlichen Fragen der Keimprüfungsmethode. 69 pp. Diss. Jena, 1909.
86. RACIBORSKI, M. Über die Keimung der Tabaksamen. *Bull. Inst. Bot. Buitenzorg* No. 6. 10 pp. 1900.
87. REILING, H. Keimversuche mit Gräsern zur Ermittlung des Einflusses, den Alter und Licht auf den Keimprozess ausüben. 88 pp. Diss. Jena, 1912. (Abstr. *in Bot. Centralbl.* **123**: 346. 1913.)
88. REMER, W. Der Einfluss des Lichtes auf die Keimung bei *Phacelia tanacetifolia* Benth. *Ber. Deut. Botan. Ges.* **22**: 328-339. 1904.
89. RIJOF, N. Détermination de la faculté germinative des graines de *Phacelia tanacetifolia* dans les conditions du laboratoire. *Ann. Essais Semences* **6**: 104-110. 1928.
90. SOČNIK, HUGO. Ist die Anzucht von *Ficus elastica* aus Samen zu empfehlen? *Gartenwelt* **36**: 622-623. 1932.
91. SPOEHR, H. A. *Photosynthesis.* 393 pp. Chemical Catalog Co.; New York, 1926.
92. STEBLER. Ueber den Einfluss des Lichtes auf die Keimung. *Vierteljahrsh. Naturforsch. Ges. Zürich* **26**: 102-104. 1881.
93. TAKIGUTI, YOSISUKE. On the germination of seeds of *Oenothera*. (Japanese). *Agric. and Hort.* **5**: 748-754. 1930. (Abstr. *in Japanese Jour. Bot.* **5**: (80). 1931.)
94. TIEGHEM, PH. VAN. Structure du fruit, germination, et structure de la plantule de la *Nuytsie*. *Bull. Soc. Bot. France* **45**: 213-220. 1898.

95. TOOLE, EBEN H. A preliminary report on blue grass germination. Proc. Assoc. Off. Seed Anal. North Amer. **14/15**: 119. 1923.
96. TOOLE, EBEN H. Problems of germinating the various blue grasses. Seed World **14**: 23, 30. Aug. 3, 1923.
97. TUBEUF, C. VON. *Viscum cruciatum* Sieb., die rotheerige Mistel. Naturwiss. Zeitsch. Forst- und Landw. **6**: 497-509. 1908.
98. VRIES, HUGO DE. The coefficient of mutation in *Oenothera biennis* L. Bot. Gaz. **59**: 169-196. 1915.
99. WEINZIERL, T. R. VON. Alpine Futterbauversuche. III. 7. Versuche über den Einfluss der chemischen Lichtintensität auf die Formbildung gewisser Pflanzenorgane. Zeitsch. Landw. Versuchsw. Oesterreich **5**: 298-311. 1902.
100. WENT, F. A. F. C. Die Bedeutung des Wuchsstoffes (Auxin) für Wachstum, photo- und geotropische Krümmungen. Naturwissensch. **21**: 1-7. 1933.
101. WIENTJES, K. Accélération de la germination sans l'influence des acides. Rec. Trav. Bot. Neerland. **17**: 33-68. 1920.
102. WIESER, GEO. Der Einfluss des Sauerstoffs auf die Lichtwirkung bei der Keimung lichtempfindlicher Samen. Planta **4**: 526-572. 1927.
103. WIESNER, JULIUS. Die heliotropischen Erscheinungen im Pflanzenreiche. Eine physiologische Monographie. I. Theil. Denksch. Akad. Wiss. Wien Math. Naturwiss. Cl. **39**: 143-209. 1879.
104. WIESNER, JULIUS. Photometrische Untersuchungen auf pflanzenphysiologischem Gebiete. Erste Abhandlung. Orientirende Versuche über den Einfluss der sogenannten chemischen Lichtintensität auf den Gestaltungsprozess der Pflanzenorgane. Sitzungsab. Akad. Wiss. Wien Math. Naturwiss. Kl. Abt. 1. **102**: 291-350. 1893.
105. WIESNER, JULIUS. Vergleichende physiologische Studien über die Keimung europäischer und tropischer Arten von *Viscum* und *Loranthus*. Sitzungsab. Akad. Wiss. Wien Math. Naturwiss. Kl. Abt. 1. **103**: 401-437. 1894.
106. WIESNER, JULIUS. Über die Ruheperiode und über einige Keimungsbedingungen der Samen von *Viscum album*. Ber. Deut. Botan. Ges. **15**: 503-515. 1897.

Manuscript received by the editor January, 1934.

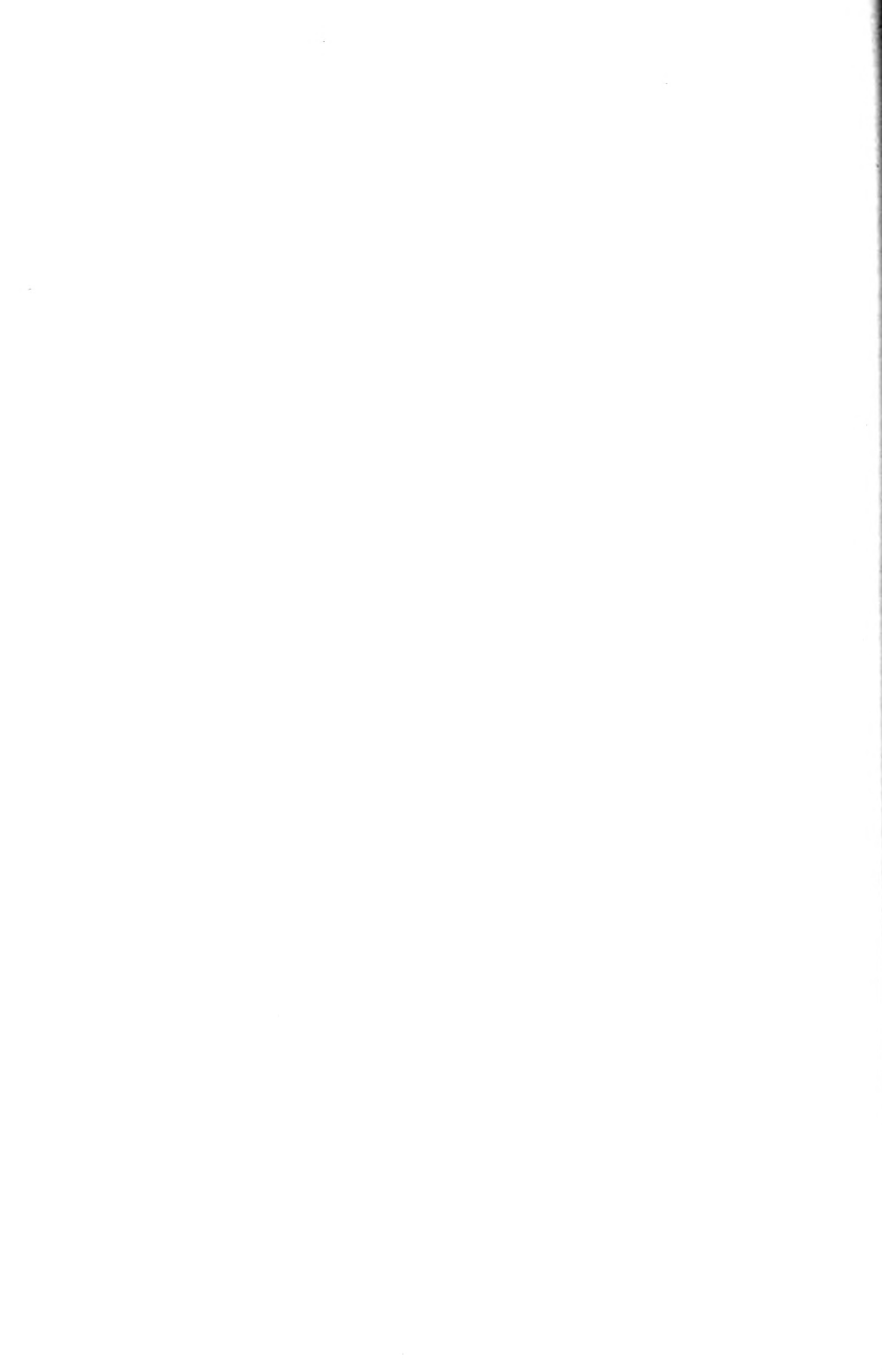

XXIV

THE EFFECTS OF VISIBLE AND ULTRA-VIOLET RADIATION ON THE HISTOLOGY OF PLANT TISSUES

J. T. BUCHHOLZ

Department of Botany, University of Illinois

Anatomical effects of darkness. Effect of different regions of the visible spectrum. Effects of ultra-violet radiation. References.

Surveying the work which has been done on the effects of the different regions of the visible spectrum on the morphological and anatomical characteristics of seed plants, it appears that investigations, beginning with those of Sachs, have been concerned more particularly with changes in the external form of the plant body. While the effects upon histological structure have been studied less intensively, important contributions have been made, and it is the purpose of this paper to bring together briefly the available information in this field. In general, the records seem to indicate, as might be expected, that the exposure of plants to various colored lights, representing restricted regions of the spectrum, does not result in many important qualitative histological changes. Under any region of the visible spectrum the stem presents the usual histological regions, that is, epidermis, cortex, and stele (containing xylem, phloem, pith, etc.), but any one of these regions may be quantitatively affected, the extent of the modification varying considerably.

It is well known from the work of Stahl (33) and of others that variations in the intensity of illumination with the full spectrum of light will bring about some quantitative anatomical changes in the tissue of the leaves. Stahl (35) demonstrated that in *Lactuca scariosa* and *Iris* the leaves have little or no palisade tissue when grown in subdued diffuse light, but there is a well-developed palisade layer when grown in bright sunlight. The development of no palisade tissue in weak light as contrasted with a high development of this tissue in strong light might even be considered a qualitative change. In the respect mentioned, leaves on the same trees will vary considerably, so that the sun leaves taken from the exposed upper part of the tree will appear different from the shade leaves found in the lower interior of the tree.

The external growth effects of colored lights are well summarized by Davenport (6). The earlier experiments on the effects of light intensity are usually included in the textbooks of physiology and anatomy (Jost, 13; Haberlandt, 12; Küster, 19).

ANATOMICAL EFFECTS OF DARKNESS

It is well known that an effect of darkness is to produce etiolation. The generalization is also made that the effect of the red rays is very similar to that of darkness. Thus a plant subjected to red light becomes etiolated, though it may develop chlorophyll or retain its chlorophyll and function in carbon assimilation. Anatomical investigations on etiolated organs have been made by several investigators. A series of studies by Priestley and his students is discussed below. Priestley (26) describes the general anatomy of the etiolated and normal plant of *Vicia Faba* L. and of *Pisum sativum* L. These plants show a very characteristic growth response in darkness. It is typical of the response to be expected of many dicotyledonous plants. In darkness, there is attenuation and not only an absolute reduction in the cross-sectional area of the stem of *Vicia* and *Pisum* but also a change in proportions of cortex and stele. Along with the decrease in the diameter of the stem, there is an even greater decrease relatively in the stelar area of the cross section, that is, the stele suffers a greater relative reduction than the cortex. In etiolated plants exposed to an hour of daylight per day, these conditions have been found to be intermediate.

In a paper by Priestley and Ewing (27) a very striking difference is pointed out in the development of the endodermis. The endodermis may be absent from the stem in a normal plant of *Vicia*, *Pisum*, and many other dicotyledonous plants, or, when the plants are grown in full daylight, it may be present only at the very base of the stem just above the cotyledons. In plants subjected to etiolation this layer is more fully developed in the stem, often with the characteristic Casparian rings. However, the authors point out that observations on etiolated specimens of *Phaseolus* sp. indicate that this plant does not respond by producing an endodermis upon etiolation. Furthermore, there are many dicotyledonous plants, for instance, some of the mints, which show an endodermis when normally grown in light.

After further study of this feature, Priestley (26) pointed out that in the very young tip of the plumular shoot of an etiolated plant no primary endodermis can be found, but that a well-marked starch sheath surrounds the stele as well as the cortical bundles, and as we pass to lower or slightly older levels of the young stem the starch sheath disappears and is replaced by the endodermis. Thus the starch sheath disappears and gives way to a primary endodermis acropetally as the stem develops in darkness. The effect of darkness upon the structural growth "has mainly to be looked upon as a change in sequence of the developmental stages by which differentiated tissues are being formed at the growing apex." In darkness the stem tends to take on some of the internal characteristics of roots.

Priestley also records the starch distribution and other histological changes which accompany the formation of the plumular hook of an etiolated stem; he describes an interesting non-plasmolysis of the cortical cells of etiolated plants, though the cells of similar regions will show plasmolysis, if tested about 24 hr. after a short exposure to light. Priestley and Woffenden (28) report that in etiolated plants there is only a small production of wound cork in response to superficial wounds. The structure of etiolated monocotyledons is reported upon in a paper by Scott and Priestley (32).

The effect of visible light and darkness on plants, with limited periods of illumination, seems to offer possibilities as an added tool at the disposal of the plant anatomist who may be interested in a more comprehensive knowledge of the possible induced variations in plant anatomy, for example, such features as the primary endodermis, which is often absent or difficult to observe in the stems of higher plants.

Schloss-Weill (31) described histological differences resulting from etiolation which were due largely to the elongation of cells rather than to an increase in the number of cells, in the stem of an aquatic plant, *Ceratophyllum*. Küster (19) includes a number of references to the effects of intensity of light and to light of various colors.

EFFECTS OF DIFFERENT REGIONS OF THE VISIBLE SPECTRUM

The effect of lights of different intensities and qualities on the growth of the fern prothallia of *Pteris longifolia* are given by Klebs (14). Corresponding to the degree of light intensity, Klebs obtained elongated cells in the thallus in comparative darkness and in red light. Under intense illumination and in blue light the cells were short with many cell divisions and there was a broadening of the thallus.

Pfeiffer (25) has given us an account of some of the anatomical differences which are recognizable in certain dicotyledons, including the soy bean (*Glycine soja*), sunflower (*Helianthus cucumerifolius*), and four-o'clock (*Mirabilis*), grown under various colored lights. These plants were grown out-of-doors and in the special greenhouses of the Boyce Thompson Institute for Plant Research which included a "visible-spectrum" house (*vs*, 7200 to 3900 Å), a full-spectrum house (*fs*, 7200 to 2900 Å), a blue house (*b*, 5850 to 3350 Å), minus violet house (*mv*, 7200 to 4710 Å) and a red house (*r*, 7200 to 5260 Å). However, the intensity of the light in these houses varied so that *vs* and *fs* were at slightly more than half the light intensity of the out-of-doors, *b* had only about one-sixth of the intensity of *vs* and *fs*, while *r* had slightly more than half of the intensity of *vs* and *fs*. The summary of this report places the emphasis upon comparisons of the total amount of tissue development of stem, leaf, and root. This study also shows definitely that the quality of the light affects the thickness of the leaves, for though the light in *r*

was more than three times as intense as that in *b*, the leaves were thicker in *b*, and slightly better differentiated; they were also slightly superior to those in the minus violet house (*mv*) which had nearly the same light intensity as *fs* and *vs*. However, for leaves, the last mentioned were superior to all of the colored lights and showed very nearly the same conditions as the cross sections of the leaves of outdoor plants.

Plants exposed to the "visible spectrum" (*vs*) showed greater diameter and height of stem than was found in control plants growing out-of-doors, but the outdoor plants showed greater vascular development than the former. It appears that minus violet (*mv*) caused better vascular development than blue (*b*) or red (*r*). Leaf development, as shown by the thickness of the sections and tissue differentiation in the leaf was greater in *b* than *mv* and least in *r*, while root development was very similar to leaf development with *mv* superior to *b*.

The comparisons of the total cross-sectional area of the stem in terms of the stele, following the method of Priestley (26), are not given by Pfeiffer. (See also *New Phytologist* 21: 60-61. 1922.) However, from a study of the photomicrographs of the cross sections of soy bean and sunflower stems which are shown in the plates (using sectors in many cases and estimating the cross-sectional areas of the whole stem compared with the stelar area) one finds an indication of the same general conditions as in Priestley's etiolated stems. Whether only the full-spectrum and visible-spectrum houses are used as standards of comparison, or the out-of-door plants are included in the standard, makes little difference. The stelar areas are not so well developed in any of the houses with colored lights of reduced intensity, but in this analysis the blue seems to result in stem structure which compares very favorably with the minus violet and red lights of many times greater intensity.

In an investigation embracing 43 experiments with liverworts, ferns, and flowering plants, Teodoresco (38) used white light and two colored lights: red-orange and blue-violet. Double-walled bell glasses filled with 7-cm. layers of 10 per cent potassium bichromate solution were used as filters for orange-red light, and similar bells filled with 3.2 to 4.25 per cent ammoniacal hydrated copper sulfate solution served as filters for the blue-violet. The energy content of the transmitted light was measured by means of a thermocouple and adjusted to comparable conditions of intensity under these filters by diluting or concentrating the liquid of the filter and by supplementing the illumination by electric light. Plants well supplied with reserve foods were selected for most of the tests and the experiments terminated before the supply of reserves was entirely exhausted. The tubers, bulbs, and seeds of higher plants were planted in sand, some older plants in pots, while the spores of lower plants were planted in 2 to 5 per cent agar containing $\frac{1}{10}$ of the standard

Knop nutrient solution. He also constructed some special glass color-filters, which are described.

Teodoresco found, as he did in a very similar investigation reported 30 years previously, that the red end of the spectrum has the same effect as darkness, in reducing the thickness of the leaves and their surface area and in increasing the lengths of the internodes and petioles by an increase in the length of their cells. The effect of the blue-violet light is very similar to the effect of white light, though he found slight deviations from this generalization in the responses of *Helianthus annuus* and *Menispermum cocculus*. These same general conditions were found in the germination of fern spores. The spores of *Pteridium*, which can germinate in darkness, gave almost the same response in the red light. However, when the reserves stored in the spore are exhausted, relatively strong photosynthetic action is possible in the red light employed and the elongation may therefore far surpass that obtained in complete darkness. In the sporelings of certain liverworts the red light also causes excessive elongation; often there are long single filaments or germ tubes composed of excessively long cells which have undergone very few cell divisions. The sporelings of *Conocephalum* and *Pellia*, two liverworts, when grown in red light are shorter than those grown in white light and longer than those grown in blue light. In these experiments as in many others the shortcomings of the screens employed in respect to giving a restricted spectral region must be taken into consideration.

Teodoresco (38) emphasizes the fact brought out in his earlier investigation (37) that the blue-violet rays appear to be more favorable and more adequate for the normal form development of the plant than the red rays.

This investigation, employing plants with reserve foods, supports the view that photosynthesis may take place in the red light, which may in turn support a considerable amount of growth (elongation) which is not brought about by the direct photomorphic effect of this portion of the spectrum. Plants with abundant reserve foods may therefore be expected to respond somewhat better to the blue-violet portion of the spectrum.

We find a very interesting record by Förster (10) working with another liverwort, *Marchantia polymorpha*, who used Hübl's filters (Nos. 2, 11, and 20) and grew the thalli from gemmae under red, green, and blue filters. He adjusted the different filters and his mixed-light controls to the same intensity and found that in general the growth responses under the red filters were as good as under white light; the green light was only about $\frac{1}{20}$ as effective as the mixed light of the same intensity and blue light markedly inferior to the red. The air chambers found in the upper layers of the thallus were normally developed in red light; they were formed, but without the special assimilatory cells

normally found in the air chambers, in the blue light, and in the green light very few of the air chambers were formed. Chloroplasts were disk-shaped under the red filter and round under the blue.

Thus we find that there are some apparent contradictions in the results of the various investigators, especially with reference to the photomorphic effect of the blue light. Of course, in Förster's (10) work the gemmae used in the experiments are not supplied with a great amount of reserve food. It might appear then from his work, at least, that the red light is there playing a photomorphic role, since in the blue light the air chambers of the thallus were lacking, while in the red these chambers developed. The origin of the assimilatory cells certainly involves more than cell elongation, it requires several cell divisions which were not carried out under blue light. Thus it seems wise in the present state of our knowledge to draw only provisional conclusions concerning the specific effects of light rays of different parts of the spectrum.

Likewise, we should be cautious in drawing conclusions concerning the effects of light on internal structure. Kohl (16) obtained very marked differences in the internal structure of leaves and of stems of a number of seed plants after exposure to conditions of high transpiration as contrasted with low transpiration. On the other hand, Burgerstein (3, 4), whose monographs summarize and discuss the work of many investigators on transpiration, including effects of various colored lights on this process, makes it clear that the transpiration rate is not the same when plants are grown under lights of different colors.

Toward all experiments involving either intensity or quality a critical attitude should be maintained, especially in large-scale plant study, in regard to the specific influence ascribed to this factor unless it is quite clear (*a*) that change in intensity does not at the same time involve change in quality, or the reverse, and (*b*) that the screens or filters selected shall transmit with sufficient purity the spectral region under study.

EFFECTS OF ULTRA-VIOLET RADIATION

Investigators reporting on the effects of ultra-violet radiation are more nearly in agreement with respect to the general effects of this form of radiation than are those reporting on intensity and quality effects. Nearly all investigators of recent years have employed mercury-vapor-quartz tubes. There is unanimous testimony concerning the development of a shiny leaf surface, due to the killing effect on the epidermal cells. Investigators are further agreed that the ultra-violet rays do not penetrate very deeply into plant tissues, that their highly destructive effect is usually confined to one or more superficial layers of cells.

Siemans (33), Dehérain (7), and Bailey (1) recorded damaging effects of a naked electric arc on growing plants but the plants were found to be protected from the damage by filtering the rays through glass. Bailey

stated that this injury was localized in the epidermis, since microscopic examinations revealed that the surface layer had collapsed. The collapse of these cells was explained as due to a loss of water from the epidermal cells to the more active chlorenchyma cells beneath.

Maquenne and Demoussy (20) repeated Dchérain's experiments with a quartz-mercury-vapor lamp. By means of plasmolytic tests they showed that the epidermal cells were killed, but that the palisade cells of the interior of the leaf remained uninjured.

Hertel (11), one of the earliest investigators to experiment on the effects of ultra-violet radiation on bacteria and other microorganisms, also made some microscopic examinations on the effect of the magnesium line (2800 Å) on the cells of living *Elodea canadensis*. He reported the cessation of protoplasmic streaming and death of the treated cells. The killing effect on the epidermis of seedlings by ultra-violet radiation was further confirmed by Stoklasa (36) who pointed out that the greening of etiolated seedlings was hastened by exposure to the ultra-violet radiation employed.

In a series of investigations on the effect of ultra-violet radiation on higher plants (*Aucuba japonica*, *Echeveria* sp., and *Sempervivum* sp.) Kluver (15) used a quartz-mercury-vapor lamp (range 90 to 220 volts, usually operated at 100 volts and 3.5 amp.). He subjected his plants to a single exposure of the radiation and discovered the latent effect, that the reaction of his plants to the ultra-violet treatment would begin to show some time after the exposure. He found also that short treatments would kill only individual cells of the epidermis and that the lower epidermis is more vulnerable to ultra-violet than the upper. The guard cells of the stomata require longer treatment than ordinary epidermal cells, and the subsidiary cells which adjoin the stomata, though otherwise unrecognizable from their form, become recognizable from ordinary epidermal cells as chemically differentiated structures by their less susceptibility to ultra-violet.

Kluver also investigated the effect of ultra-violet radiation on anthocyanin. After ascertaining that the extracted anthocyanin remains stable after exposure to ultra-violet radiation, he found that living cells of a *Begonia* leaf, except those at the veins of a leaf, which are covered by an additional layer of collenchyma cells, lose their anthocyanin with the death of the epidermal cells. Other experiments on anthocyanin in leaves as affected by ultra-violet rays are given by Schanz (30).

After prolonged treatment of stems such as those of *Phaseolus multiflorus*, Kluver found that all of the cortical tissues on the exposed side of the stem collapsed. The xylem cells on the same side gave less lignin staining reaction (phloroglucin and hydrochloric acid) than did those on the unexposed side, and the bast fibers of stems with bast were similarly affected.

While Kluyver and previous investigators subjected plants to a single exposure of ultra-violet and studied the subsequent effect on the plants, we find other records of the exposure of plants to continuous irradiation. Raybaud (29) grew cress seedlings (*Lepidium sativum*) with continuous exposure under a quartz-mercury-vapor lamp at 1.5 meters and obtained the epidermal killing effect reported by others as well as changes in the deeper tissues. The dead epidermal layer served as a protection to the deeper layers from the harmful action of the rays, but as subsequent growth ruptured the epidermal cells, the exposed cortical cells were killed in turn. The cortical cells of the hypocotyl were so affected that they divided periclinally and elongated on the side exposed directly to the light, with a consequent curvature of the hypocotyl toward the opposite side. Deeper and deeper layers of cells were destroyed as the surface became reticulated and opened into longitudinal furrows or grooves.

Delf, Ritson, and Westbrook (8) exposed plants (*Trifolium*, *Voandzeia*, *Pelargonium*, etc.) periodically (several minutes daily) to the radiations from a quartz-mercury-vapor lamp and obtained effects similar to the previous investigations—collapsed epidermal cells followed by rolling and distortion of the leaves during subsequent growth. They obtained these effects on *Voandzeia subterranea* after only three daily exposures of 2 min. at a distance of 3 ft.

Dane (5), who treated soy beans with ultra-violet, reported the stems 1.5 times as great in diameter as control plants. The rayed stems were hollow and showed a reduction in the width of the medullary rays. Most of the ordinary parenchymatous tissue of the medullary rays developed into vascular tissues—xylem and phloem. The plants which were exposed were more stunted and their tissues stiff and brittle.

Eltinge (9) investigated the effects of periodic treatments on a great variety of seed plants by dosages which began with 30 seconds exposure the first day and were increased by this amount daily. The ultra-violet radiation source was a uviarc quartz-mercury lamp emitting rays from 5780 Å down to 2000 Å. This lamp was used in a series of experiments at 50 and 100 in. both with and without glass filters. The filters used were "vita" glass (transmitting 5780 to 2890 Å) and "quartz-lite" glass (transmitting 5780 to 3136 Å). Leaves were taken for anatomical study from the unscreened series at the end of 4 weeks; at the end of 8 weeks samples of leaves and stems were taken from all plants, which were killed with medium chromic acetic killing fluid and sectioned in paraffin. Some were stained in Haidenhein's iron alum haematoxylin and others with safranin—Delafield's haematoxylin for microscopic study.

Many anatomical details are described in this paper. Injury was greatest in the unscreened series with an early deadening of the epidermis; where occasional epidermal cells escaped the killing they were distinctly smaller. The anthocyanin pigment disappeared in all parts of stems and

leaves. The contents of palisade cells were drawn away from the upper ends of the cells and the injury to the newly formed leaves was evident throughout the entire leaf. Not only were the air spaces fewer but there was much less differentiation between different kinds of cells, suggesting that ultra-violet treatment may retard growth in individual cells, even though they escape destruction. This work suggests that the penetration of some of the unscreened ultra-violet radiations may extend through the entire leaf.

The histological details of sections of leaves of *Lactuca sativa*, *Nicotiana Tabacum*, *Phaseolus vulgaris*, *Cucumis sativus*, *Ipomoea Batatas*, *Zea Mays*, *Coleus Blumei*, and one of its varieties are included in the illustrations of the plates. These are all consistent in showing a distinct correlation of the degree of injury with the severity of the treatment under the different conditions of the experiment, but it is hardly possible to conclude that all observed effects may be attributed exclusively and with certainty to the action of the ultra-violet radiation.

Where "vita" glass was used, screening out rays of less than 2900 Å wave-length, the general results were reported to be beneficial to the plants. There were no lesions, though the newly formed leaves of several species (*Lactuca*, *Raphanus*, and *Coleus*) were thinner than the controls. Some plants had leaves thicker than the controls but in these cases the treated plants themselves were larger. Under "vita" and "quartz-lite" glass *Coleus* plants showed not only an increase in growth, with a corresponding increase in leaf thickness, but also a complete retention of the red pigment. The effect of filtered ultra-violet on stems resulted in greater diameter and better developed vascular bundles.

Nadson and Rochlin (23, 24), using a Bach model ultra-violet lamp, in treating *Pterygophyllum* and two species of *Elodea*, exposed at 30 cm. for 10 to 30 min., obtained crystals of calcium oxalate, formed within the cells. These crystals which were observed in some cases as beginning around the chloroplasts, increased in size and dissolved simultaneously with the death of the cell after 2 to 4 days. Treatment of the plants with narcotics before raying resulted in no crystal formation. Likewise, Beauverie and Cornet (2) studied the effect of various lengths of treatment of *Elodea* with the radiation from a quartz-mercury-vapor lamp on the cell contents. A treatment of 10 to 30 min. at 4 meters distance gave no morphological changes after 45 min. or more of treatment. Granulations were produced in the chloroplasts of individual cells, while in the cells of others they remained hyaline. Treatment for $4\frac{3}{4}$ hr. gave a change in the cytoplasm, a swelling of the granular mitochondria and chondriocents, though some of the chloroplasts were still intact.

Martin and Westbrook (21) continued the work on periodic treatments begun by Delf, Ritson, and Westbrook (8) by introducing further refinement in the technique. They standardized their dosages in terms of

arbitrary "lithopone units" (L. U.), and they demonstrated for *Pulmonaria officinalis* the relation which exists between the number of L. U. and the time which must elapse (latent period) before the death of the epidermal cells. Younger leaves were found to be more sensitive than the older ones. They present a curve showing the relationship between the intensity of the treatment and the latent period and point out that there is also a relationship between the thickness of the cutin and the sensitiveness of the leaf. Among the histological details given of the effect of ultra-violet light on leaves, they show not only that there are the changes within the epidermal cells, but also that the vacuolization and destruction of the chloroplasts and the collapse of the palisade cells take place with increased dosages.

Martin and Westbrook also tested the effects of temperature during the period of treatment, and for the latent period they found that differences of temperature between 5° and 25°C. have little effect upon the rate of browning of the epidermis. These authors also discuss the relationship between the erythema dose of the human skin and the dose causing browning of the leaves, and point out that whereas many have attempted to draw a parallel between these superficial effects, the skin recovers and the pigmentation is produced within the cytoplasm without killing cells, while the plant epidermis is killed and does not recover.

There is a structural basis for the claim that the cutin of plants is relatively opaque to ultra-violet rays. Köhler (17, 18), who used the cadmium line (2750 Å) in the photomicrography of plant tissues, shows figures in which woody cell walls and cork cells are nearly impenetrable, whereas the cuticle of leaves and stems, even in very thin places, is impenetrable to these very short rays. Metzner (22) shows that there is a similar opaqueness of cuticular and other plant-cell walls to the longer ultra-violet rays (3500 to 4000 Å) which may play a role in the influence of the sun's radiation, especially at high altitudes; thus the ultra-violet rays usually do not enter the plant and probably do not play an important formative role in nature except in the structure of alpine plants.

REFERENCES

1. BAILEY, L. H. Electricity and plant growing. Mass. Hort. Soc. Trans. 1894: 54-79. 1894.
2. BEAUVERIE, J., and P. CORNET. Action des rayons ultra-violet sur la structure cellulaire dans la feuille et le bourgeon d'*Elodea canadensis*. Compt. Rend. Soc. Biol. [Paris] 102: 775-777. 1929.
3. BURGERSTEIN, ALFRED. Die Transpiration der Pflanzen. Jena, 1904.
4. BURGERSTEIN, ALFRED. Transpiration der Pflanze. Zweiter Teil (Ergänzungsband). Jena, 1920.
5. DANE, H. REBECCA. The effect of ultra-violet radiations upon soybeans. Science 66: 80. 1927.
6. DAVENPORT, C. B. Experimental morphology. New York, 1908.
7. DEHÉRAIN, P. P. Expériences sur l'influence qu'exerce la lumière électrique sur le développement des végétaux. Annales Agron. 7: 551-575. 1881.

8. DELF, E. M., K. RITSON, and A. WESTBROOK. The effect on plants of radiation from a quartz mercury vapor lamp. *British Jour. Exp. Biol.* **5**: 138-154. 1927.
9. ELTINGE, ETHEL T. The effects of ultra-violet radiation upon higher plants. *Ann. Missouri Bot. Garden* **15**: 169-240. 1928.
10. FÖRSTER, KARL. Die Wirkung äusserer Faktoren auf Entwicklung und Gestaltbildung bei *Marchantia polymorpha*. *Planta, Arch. Wiss. Bot.* **3**: 325-390. 38 f. 1927.
11. HERTEL, E. Über Beeinflussung des Organismus durch Licht, speziell durch die chemisch wirkenden Strahlen. *Zeitsch. Physiol.* **4**: 1-43. 1904. [See also *Fuchs. Biol. Zentralbl.* **27**: 510-528.]
12. HABERLANDT, G. F. J. *Physiologische Pflanzenanatomie*. Leipzig, 1904.
13. JOST, LUDWIG. *Vorlesungen über Pflanzenphysiologie*. Jena, 1913.
14. KLEBS, G. Zur Entwicklungsphysiologie der Farnprothallien. *Sitzungsber. Heidelberger Akad.* 1916, Abh. 4; 1917, Abh. 3, 7. [From Küster, 1925.]
15. KLUYVER, A. J. Beobachtungen über die Einwirkung von ultravioletten Strahlen auf höhere Pflanzen. *Sitzungsber. Akad. Wiss. Wien Math. Naturwiss. Kl. Abt. 1*, **120**: 1137-1170. 1911.
16. KOHL, F. G. *Die Transpiration der Pflanzen und ihre Einwirkung auf die Ausbildung pflanzlicher Gewebe*. Braunschweig, 1886.
17. KÖHLER, A. *Mikrophotographie*. *Handbuch Biol. Arbeitsmeth.* (Abderhalden.) Abt. II, Teil 2, Zweite Hälfte, Heft 6, Lieferung 245.
18. KÖHLER, A. Mikrophotographischen Untersuchungen mit ultravioletten Lichte. *Zeitsch. Wiss. Mikrosk.* **21**: 129-173. 1904.
19. KÜSTER, ERNST. *Pathologische Pflanzenanatomie*. Jena, 1925.
20. MAQUENNE, L., and E. DEMOUSSY. Influence des rayons ultraviolets sur la végétation des plantes vertes. *Compt. Rend. Acad. Sci. [Paris]* **149**: 756-760. 1909.
21. MARTIN, B. T., and M. A. WESTBROOK. The influence of ultraviolet radiation upon some plant cells. *Jour. Exp. Biol.* **7**: 293-307. 1930.
22. METZNER, P. Über das optische Verhalten der Pflanzengewebe im langwelligen ultravioletten Licht. *Planta, Archiv. Wiss. Bot.* **10**: 281-313. 1930.
23. NADSON, G., and E. ROCHLINA. *Vestn. Rentgenol.* **6**: 491-500. 1928. [Russian, see *Ber. Wiss. Biol.* **12**: 15.]
24. NADSON, G., and E. ROCHLINE. Apparition des cristaux d'oxalate des calcium dans les cellules végétales sans l'influence de la radiation ultra-violette. *Compt. Rend. Soc. Biol. [Paris]* **98**: 363-365. 1928.
25. PFEIFFER, N. Anatomical study of plants growing under glasses transmitting light of various ranges of wave length. *Botan. Gaz.* **85**: 427-436. 1928.
26. PRIESTLEY, J. H. Light and growth. II. On the anatomy of etiolated plants. *New Phytol.* **25**: 145-170. pl. 2, 7f. 1926.
27. PRIESTLEY, J. H., and J. EWING. Physiological studies in plant anatomy. VI. Etiolation. *New Phytologist* **22**: 30-44. 1923.
28. PRIESTLEY, J. H., and LETTICE M. WOFFENDEN. Causal factors in cork formation. *New Phytol.* **21**: 252-268. 1922.
29. RAYBAUD, L. Influence des radiations ultraviolettes sur la plantule. *Rev. Gén. Bot.* **25**: 38-45. 2 f. 1913.
30. SCHANZ, F. Versuche über die Wirkung der ultravioletten Strahlen des Tageslichtes auf die Vegetation. *Pflüger's Arch. Ges. Physiol.* **181**: 229-248. 1920.
31. SCHLOSS-WEILL, B. Über das Einfluss des Lichtes auf einige Wasserpflanzen. *Beih. Bot. Centralbl.* **35**: 1-59. 1918.
32. SCOTT, LORNA I., and J. H. PRIESTLEY. The anatomy and development of leaf and shoot of *Tradescantia fluminensis* Vell. *Jour. Linn. Soc. Bot.* **47**: 1-28. 10 f. 1925.

33. SIEMENS, C. W. On the influence of electric light upon vegetation, and on certain physical principles involved. Proc. Roy. Soc. [London] **30**: 210-219, 293-295. 1880. [See also British Assn. Adv. Sci. **1881**: 474-480.]
34. STAHL, E. Über den Einfluss der Lichtintensität auf Struktur und Anordnung des Assimilationsparenchyms. Bot. Zeitschr. **38**: 868. 1880.
35. STAHL, E. Über den Einfluss des sonnigen und schattigen Standorts auf die Ausbildung der Laubblätter. Jenaische Zeitsch. Naturwiss. **16**: 162-200. 1883.
36. STOKLASA, J. Über den Einfluss der ultravioletten Strahlen auf die Vegetation. Centralbl. Bakt. Abt. II **31**: 477-495. pl. I-IV. 1911.
37. TEODORESCO, E. C. Influence des diverses radiations lumineuses sur la forme et la structure des plantes. Annales Sci. Nat. Bot. VIII, **10**: 141-262. 1899.
38. TEODORESCO, E. C. Observations sur la croissance des plantes aux lumières de diverses longueurs d'onde. Annales Sci. Nat. Bot. X, **11**: 201-335. 1929.

Manuscript received by the editor January, 1934.

XXV

SOME INFRA-RED EFFECTS ON GREEN PLANTS

JOHN M. ARTHUR

Boyce Thompson Institute for Plant Research, Yonkers, New York

Energy absorption of a green leaf. Absorption by chlorophyll and the possibility of photosynthesis. Transpiration in the infra-red. Injury from infra-red. References.

In general more than 50 per cent of the total energy of sunlight is in the infra-red region. This percentage varies owing to the selective absorption of the atmosphere, presence of clouds, and the distance the solar rays must travel through the atmosphere to reach the observer. In artificial light sources the percentage output of infra-red is higher. This value in case of the incandescent-filament lamp decreases with the increasing efficiency of the lamp, that is, with an increasing filament temperature. In the 1000-watt tungsten-filament lamp with an efficiency of 20.5 lumens per watt and 1000 hr. normal life the infra-red output is approximately 88 per cent of the total according to Forsythe and Watson (11). The carbon arc has approximately 75 per cent of the total energy output in the infra-red region according to the data of Coblentz and others (9) and of Karrer (15).

ENERGY ABSORPTION OF A GREEN LEAF

Both sunlight and common artificial light sources have more than 50 per cent of the entire radiant-energy output in the infra-red. It is, therefore, relevant to inquire into the known effects of this region on plants. First, it is important to determine whether infra-red is absorbed by green plant leaves, as energy must be absorbed in any region before it can accomplish a result. Very little study has been made of the infra-red absorption or transmission of leaves. Some reflection measurements have been made by Coblentz (8). He found that reflection decreased steadily from $\lambda 8000$ to $30,000 \text{ \AA}$. A red oak leaf reflected 18 per cent at $\lambda 8000$ and about 8 per cent at $30,000 \text{ \AA}$. Allowing the leaf to dry overnight caused a decrease in reflection due, Coblentz believes, to the loss of water which increases rapidly in absorption beyond $\lambda 14,000 \text{ \AA}$ and decreases the amount of radiation which can return by internal reflection. Leaves of chestnut, oak, ash, locust, and pokeberry were all found to have a lower infra-red reflection than red oak.

The average reflection for the visible region was approximately 25 per cent at $\lambda 6000 \text{ \AA}$ for a number of leaves measured. A tulip-tree leaf had a reflection of 38 per cent at $\lambda 9500 \text{ \AA}$ and 5.6 per cent at $44,000 \text{ \AA}$. Reflection was determined with the leaf at an angle of 45 deg. For other data on the absorption, transmission, and reflection of leaves in the visible region the reader is referred to the section in this work by Spoehr and Smith (Paper XXII) and that by Popp and Brown (Paper XXXI).

In order to have some specific data on the relative transmission of leaves in the infra-red and visible region the following tests were made. A hole 1 in. in diameter was made in a piece of cardboard. This was placed over a Coblenz vacuum thermopile with the hole above the sensitive elements. The leaf was placed over the hole in the cardboard. A sheet of metal was placed over this and supported at a distance of about 1 in. above the cardboard. The sheet of metal was fitted with a hole in the center 5 in. in diameter over which glass filters were placed. The infra-red only filter was a piece of Corning's heat-transmitting glass 4 mm. in thickness. The visible-region filter, used for absorbing infra-red, consisted of a circular glass dish containing 1 cm. of water and a piece of Corning's heat-absorbing glass approximately 3 mm. in thickness. The transmission of the two filters has been given in a previous publication (1). A 1500-watt lamp was used as a light source, suspended directly above the thermopile. Allowing for a 20 per cent reflection in both the infra-red only and visible region, the percentage transmission of various leaves was as shown in Table 1.

TABLE 1.—INFRA-RED AND VISIBLE TRANSMISSION OF LEAVES IN PER CENT AFTER ALLOWING 20 PER CENT FOR REFLECTION

Plant	Infra-red	Visible
Sunflower.....	30	23.3
Tomato (Magnus).....	22	19.0
Tobacco (Turkish).....	30	22.0

The figures indicate that the transmission as determined in this way is slightly less in the visible region than in the infra-red. In addition to the errors arising from the selective reflecting power in the two regions already discussed, these figures when applied to sunlight are open to another error in that the incandescent lamp has considerably more infra-red and less visible energy than sunlight. Much more work needs to be done on the effects of photosynthetic materials, water, and mineral salts present on the infra-red absorption of various leaves. It is evident, however, that a high percentage of infra-red is absorbed by the leaf. This being the case, interest is directed toward a further study of what becomes of the energy absorbed.

ABSORPTION BY CHLOROPHYLL AND THE POSSIBILITY OF PHOTOSYNTHESIS

Brown and Escombe (4) have estimated that less than 0.5 per cent of the total energy absorbed by the leaf is used in photosynthesis. This energy is absorbed in certain well-marked absorption bands found in chlorophyll in the visible region. The infra-red absorption of chlorophyll has been studied by Ursprung (21) who has reviewed the older literature on this subject. He found that the pigment in solution absorbed about 7.5 per cent as compared with a value of 10 to 17 in the leaf. An iodine solution was used in obtaining infra-red with a Nernst lamp as a source. Gulik (12) using Willstätter's preparations determined the absorption of *a* and *b* chlorophyll solutions at various wave-lengths to 35,380 Å. He found weak absorption in the *a* component to 10,040 Å. The absorption constant for a given concentration at 6460 Å was 2.48, at 7730 Å it was 0.234, and at 10,040 Å it was 0.078. A weaker secondary absorption was found with a maximum at 33,870 to 34,040 Å. The *b* component had little absorption in the near infra-red but had a weak absorption at 33,840 Å. Carbon bisulfide was used as the solvent in this work. Since there is an absorption by one of the components of chlorophyll, there is the possibility of photosynthesis in the infra-red region. Ursprung (21) exposed a bean leaf for 40 hours to infra-red using both an ebonite plate and a solution of iodine as a filter to isolate this region. Using the iodine-starch test he showed that some starch was formed under infra-red alone. A photograph of the blackened area is shown. He states that not every experiment of this type succeeds and that a lens must be used which concentrates just the right intensity of energy upon the leaf. He found that the stomata remained closed during the experiment and concludes that the failure of plants to assimilate more rapidly in the infra-red is due to the closure of stomata, thus limiting the intake of carbon dioxide. Sayre (19, 20) has recently observed that the stomata of *Rumex patientia* do not open at wave-lengths greater than 6900 Å and that chlorophyll is not formed in this region. Arthur (2) found that buckwheat seedlings were not able to produce chlorophyll under infra-red radiation and were identical in appearance and dry weight with those grown in darkness. They grew only at the expense of the food stored originally in the seed. A photograph of these seedlings grown both in darkness and exposed to the infra-red region of sunlight is shown in Fig. 1. He also found that when such seedlings were grown under incandescent-filament lamps operating at low and high efficiencies, the dry weight of tissue produced was proportional to the energy in the visible region and independent of the proportional part of infra-red. There is the possibility that plants grown with the visible energy of sunlight in a greenhouse during the day might

be able to carry on limited photosynthesis when placed under infra-red at night. This test was made recently as follows:

Four pots of buckwheat seedlings were grown in a greenhouse during the months of December and January under solar illumination during the day and under the infra-red from a 500-watt lamp each night. A composite filter made up of Corning's heat-transmitting glass 4 mm. in thickness was used to remove the visible region. The transmission of this glass has been indicated in a previous publication (1). The filter was supported on a wooden stand a short distance below the lamp. The distance from the lamp to the soil in which the seedlings were grown was 22 in. The lamp was fitted with an aluminum reflector for directing

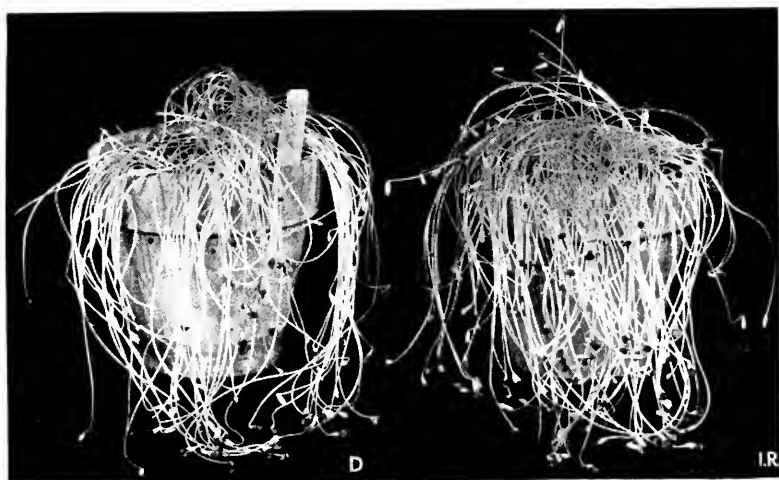

FIG. 1.—Buckwheat seedlings. *D*, at left, grown in darkness. *I.R.*, at right, received only the infra-red of sunlight. Note that there is no difference in the appearance of the two. The green pigment chlorophyll does not develop under infra-red.

the radiation downward so as to cover the filter effectively. A second set of four plants was grown beside the first set and was treated similarly except that a sheet of galvanized iron was used under the second lamp instead of the infra-red filter. The seedlings were grown for two weeks, then were cut down and green and dry weights determined. This test was repeated during January and February. In each test the seedlings were grown from seed for approximately two weeks before they were placed under the test conditions. The results are shown in Table 2.

The seedlings in the first test were grown during a period of cloudy weather and produced much less dry weight than those in the second test. There is no evidence, however, that those grown under infra-red each night produced more dry weight. There is some indication that the plants receiving infra-red weighed less than the controls under sheet metal. This might be expected since respiration would probably be higher under the infra-red conditions owing to the higher temperature

of the plant tissues brought about by the radiation. The data are not conclusive as regards this point.

TABLE 2.—GREEN AND DRY WEIGHTS OF BUCKWHEAT SEEDLINGS GROWN UNDER SUNLIGHT DURING THE DAY AND UNDER INFRA-RED EACH NIGHT DURING A PERIOD OF TWO WEEKS

	Number of plants	Green weight per plant, gm.	Dry weight per plant, gm.
First test			
Under infra-red.....	32	1.06	0.059
Under infra-red.....	37	1.13	0.060
Under sheet metal.....	35	1.20	0.063
Under sheet metal.....	36	1.18	0.064
Second test			
Under infra-red.....	46	1.92	0.102
Under infra-red.....	50	2.23	0.124
Under sheet metal.....	53	2.13	0.112
Under sheet metal.....	49	2.40	0.134

In this connection the work of Johnston (14) is especially significant. He grew tomato plants in four chambers using 1000- and 1500-watt lamps. Temperature and humidity were accurately controlled by recirculation of air. Two types of filters were used and two illumination values as measured by a Weston photronic cell with a Corning heat-absorbing filter. The filters were (a) Pyrex glass plus water 1.5 cm. in thickness, and (b) Pyrex glass plus water 1.5 cm. plus Corning's heat-absorbing glass 8 mm. thick. The water-layer filter transmitted to $\lambda 14,000 \text{ \AA}$. The other filter was designed to have a transmission curve which coincides approximately with the sensitivity curve of the human eye. Under one filter of the Pyrex-plus-water type the illumination was 339 foot-candles, under the other of this type it was 1966 foot-candles. The corresponding illuminations under the two heat-absorbing glass-plus-water-type filters was 359 and 1966 foot-candles. The dry weight of tissue produced was as follows:

	Foot-candles	Dry weight, mg.
Pyrex plus water.....	339	126
Pyrex plus water.....	1966	426
Heat-absorbing glass plus water.....	359	16
Heat-absorbing glass plus water.....	1966	199

Although the dry-weight production was greater for plants receiving infra-red, these plants were not so green as those receiving only visible light. This destruction of chlorophyll may, however, be ascribed to the red region as well as to the infra-red. Johnston points out that in the region of the strongest chlorophyll-absorption bands the plants grown in the distribution including the infra-red received some three times greater intensity of radiation. It is probable that this action on chlorophyll would occur in the region of greatest absorption. Guthrie (13) has shown that plants grown without the blue-violet region of sunlight also produce less chlorophyll. There is some indication, therefore, that even the visible red, where blue-violet intensity is low, is injurious to chlorophyll. Johnston has definitely shown that normal-appearing tomato plants can be grown without the infra-red. The increase in the dry weight of tissue produced under the infra-red transmitting filter is no doubt due to the greater energy transmitted in the red region of the visible spectrum.

It follows from this discussion that, while there is an absorption of chlorophyll in this region and the possibility of some starch formation, as indicated by the work of Ursprung, photosynthesis in the infra-red is negligible and during a considerable period of exposure of green plants to this energy it contributes little or nothing to the dry weight of plant tissue produced.

TRANSPIRATION IN THE INFRA-RED

The work of Brown and Escombe (4) indicates that by far the greatest consumption of total energy received by the green leaf is in transpiration. The amount used in this way, they found, amounted to as much as 60 per cent of the total received. It is probable, therefore, that the evaporation of water performs the important function of dissipating excess energy in both visible and infra-red radiation. This is the method which the animal uses to maintain a body temperature often several degrees below that of the surrounding air. Such a cooling mechanism is even more important in the case of plants, as these must remain fixed in the soil and exposed to any fluctuating temperature and light intensity which the vagaries of a given climate can produce, and at the same time hold the temperature of the leaves and stems below the thermal death point.

Older literature on the subject of plant transpiration, based on a study of water losses from plants growing under field conditions, showed that transpiration rose to a maximum each day and fell off to a very low value at night. Stomata were found quite generally open in light and closed in darkness. There was some indication, therefore, of a regulation of water loss by stomatal movement. It has been pointed out already that stomata do not open under infra-red. The possibility, therefore, of plants losing sufficient water through cuticular transpiration to eliminate

excess energy received in this region is of special interest. Johnston (14) observed that plants grown in chambers where infra-red radiation was present were found to be more economical in their use of water than those grown with visible only. This indicates that plants lose less water under infra-red than under visible radiation. In order to obtain more data on transpiration as related to both infra-red and visible energy a study was made by Arthur and Stewart (3) of water losses from tobacco plants grown under various conditions of temperature, humidity, and radiation intensity with both the visible plus infra-red and infra-red regions only. In this work 1000- or 1500-watt tungsten-filament lamps were used and standard air-conditioning machinery served to control temperature and humidity. Corning's heat-transmitting glass was used to absorb the entire visible region. Plants were potted in metal containers and were sealed in with a paraffin mixture so that all water loss was through the leaf and stem surfaces of the plant. Using the lamp without a filter (visible and infra-red) within a temperature range of 73° to 78°F., it was found that doubling the total energy increases the rate of water loss by 1.74. This was found to be independent of humidity within a range

of 50 to 88 per cent relative. At an energy level of 0.22-gm. cal./cm²./min. the loss at this temperature was almost twice as great under infra-red plus visible conditions as under infra-red alone. At a higher energy level (0.65 to 0.72 gm. cal.) and at the same temperature the loss under visible plus infra-red was 2.5 times that under infra-red alone. When the temperature was increased to the range 98° to 100°F., the infra-red rate of loss increased rapidly as compared with that under visible plus infra-red so that the visible loss was only 1.3 times that of the infra-red. High humidity (87 per cent relative) at this high temperature produced a slight decrease in water loss in both infra-red and visible plus infra-red conditions and produced great injury on most of the leaves. In Fig. 2 are shown two tobacco plants which were used in this transpiration study. The plant at the left shows the leaf injury which developed after exposure to infra-red at high temperature and high humidity. The plant at the right is the normal plant. The water loss in darkness was increased first by the increase in temperature and again by the increase in humidity. At the lower temperature range the amount lost in darkness



FIG. 2.—Tobacco plants sealed in porcelain enamel cups for transpiration study. Left, plant injured by combination of high infra-red, high humidity, and high temperature. Right, normal plant.

was almost negligible. Under the most favorable conditions for water loss (high temperature, high radiation, and low humidity) the water loss per square inch of leaf area (calculated on one surface per leaf only) reached a maximum value of 2.82 gm. in 12 hr. under visible plus infra-red, and 2.09 gm. under infra-red only. If this high rate were maintained in large tobacco plants with 3000 in.² of surface the water loss in 12 hr. for visible plus infra-red might amount to 8 l. as compared with 6 l. for infra-red only. This study was made with plants reduced mainly to three leaves. It is probable that the rate would fall off considerably as more leaves were added since not all leaves would be well exposed to the light.

The percentage of energy received which was eliminated again by evaporation of water in the infra-red region was calculated as approximately 72.5 per cent. This calculation is based upon an incident energy value of 0.65 gm. cal./cm.²/min. and a loss of 20 per cent by reflection and a second loss of 30 per cent by transmission using the figure 2.09 gm. of water lost per square inch of leaf surface in 12 hr. and assuming the value 585.3 as the latent heat of vaporization of water at 20°C.

It is seen from the foregoing study that, as the thermal death point of leaves is approached through increases of temperature and radiation intensity in either visible or infra-red, transpiration increases rapidly, and cuticular transpiration in the infra-red becomes a large part of the total transpiration (stomatal plus cuticular) under visible-radiation conditions. The fact that the cuticular transpiration rate does not quite overtake stomatal plus cuticular rate probably accounts for the more severe injury obtained under infra-red at high temperature as compared with visible plus infra-red.

Curtis (10) and Clum (6, 7) have challenged the idea which has grown among plant physiologists that transpiration cools plants by the evaporation of water. Curtis admits that the evaporation of great quantities of water is an efficient method of eliminating large amounts of excess energy received, but states that no evidence has been obtained which shows that stopping transpiration actually produces a rise in the temperature of plant leaves. Clum found that when plant leaves were coated with vaselin, only a slight rise in temperature could be observed when thermocouples were inserted into the leaf lamina. Arthur and Stewart (3) observed that when tobacco leaves which had been thoroughly coated with vaselin on both sides were placed in a cellophane envelope, water vapor escaped from the leaf through the vaselin and condensed on the inner surfaces of the cellophane envelope. When the leaf was placed in such an envelope and exposed to a total energy value of 1.6 gm. cal./cm.²/min. using a 1000-watt lamp, the leaf temperature rose from 87° to 127°F. in an exposure of 4 min. The cellophane envelope they concluded effectually prevented all cooling of the leaf by the evaporation of water, as the water evaporated was again condensed, resulting in low-energy

emission from the leaf-cellophane system, while the vaselin coating did not decrease transpiration sufficiently to produce any considerable rise in temperature. Leaves enclosed in cellophane and exposed for 15 min. developed large necrotic areas as a result of the treatment when the plants were placed in a greenhouse for two days. No visible signs of injury could be observed when the leaves were first removed from the envelope. However, a distinct aromatic odor was given off by the treated leaves when first removed. This temperature was above the thermal death point of the leaf. At higher radiation values, up to 1.6 gm. cal., the leaf temperature when permitted to transpire freely, was found never to exceed 107°F. under either visible or infra-red alone conditions. The leaves were found to hold this temperature by increasing the water loss. The tendency to maintain a higher leaf temperature under infra-red as compared with the visible region of the same energy value is believed to be due to the lower transpiration rate under infra-red.

The conclusion seems well established that plants can and do eliminate most of the excess energy received in both the visible and infra-red regions by the evaporation of water. Whether the transpiration stream through the plant serves another essential purpose besides the cooling effect in the life processes of plants is beyond the scope of this discussion. In so far as the transpiration stream is useful in plant processes, the infra-red region can be considered as of value to the plant in maintaining this stream. Indirectly it serves to heat the soil and the surrounding air so as to produce a more nearly optimum temperature for plants. This is also true of visible radiation. It is perhaps significant that plants do not grow well in desert countries where radiation and temperature are high but the water supply is limited. In order to conserve the available water, desert plants have a decreased leaf area exposed to radiation and this in turn decreases photosynthesis and growth. Plants produce most abundantly only where an adequate transpiration stream can be maintained to supply large areas of leaves exposed to radiant energy.

INJURY FROM INFRA-RED

Burns (5) recently found that infra-red radiation longer than $\lambda 11,000 \text{ \AA}$ was slightly detrimental to photosynthesis when the plant is at a sufficiently high temperature. His method was to expose potted seedlings of white pine or spruce sealed in bell jars to the total output of four 1000-watt lamps placed at the four corners of a rectangle. The plants were placed in the center of the rectangle and the amount of carbon dioxide decomposed in a 2-hr. observation period when exposed to the total output was compared with the amount decomposed when exposed similarly except that the output of each lamp was filtered through 1 in. of water plus two layers of plate glass, each 3 mm. in thickness. The total energy used in the two types of exposure was of the order of 3 to 1. The effi-

ciency of infra-red plus light as compared with light alone (using the water filters) ranged from 85.5 to 99.0 for pine seedlings. The temperature in the series of infra-red experiments ranged from 27.0° to 33.5°C. This is presumably air temperature under the bell jars. While no record of the tissue temperature under the two conditions of illumination is given, there is the possibility that this was somewhat higher under the visible plus infra-red conditions since the energy level used was more than three times as great. This possible increase in temperature might account for the slight decrease in efficiency at the higher energy level. Burns noted that the temperature coefficient of photosynthesis at 28°C. is so near one that no effect of temperature can be detected in his experiments. Lundegårdh (17), however, working with broad-leaf plants, has shown that this quotient is often less than one with low light intensity and higher carbon dioxide concentrations (1.22 per cent) and that the amount of carbon dioxide assimilated falls off with increasing temperature from 25° to 35°C. Other factors such as respiration and stomatal opening should also be considered. In the absence of further data it cannot be regarded as definitely established that the infra-red of wave-length longer than 11,000 Å is detrimental to photosynthesis.

Attention has already been directed to the injuries on leaves produced by high infra-red along with high temperature and high relative humidity. It is probable that only under extreme conditions could such an injury result except where plants were limited in the amount of water supplied them. There is the possibility of injury, however, in the case of plant organs exposed to infra-red, which, on account of the nature of the epidermis, either cannot lose moisture or lose it only in insufficient amounts to take care of the radiation supplied. Arthur (1) has observed a case of this kind. Apples were kept in an insulated box, the air temperature of which was maintained at about 2°C. A 500-watt Mazda lamp was suspended over the box at a distance of approximately 30 in. above the fruit. A filter made up of Corning's heat-transmitting glass was placed over the box at a distance of 24 in. below the lamp. After five days' exposure to the infra-red output of the lamp, a wrinkled, necrotic area developed on the side of the apples exposed. The internal temperature of the apples was found to be about 20°C. higher than the surrounding air. While this temperature was considerably above that of the air, it was believed that it was not sufficiently high to have caused the injury on the upper surfaces of the apples. The injury was thought to have been produced by the direct action of infra-red on a tissue which absorbs it freely. A second test was made using the visible output of the same lamp as transmitted by a filter consisting of 1 cm. of water and Corning's Aklo heat-absorbing glass. No injury was produced. It should be pointed out, however, that the energy value in this case was much less as the distance from the lamp to the fruit remained the same. It is

possible that an equal amount of energy in the visible region would have produced a similar injury. More work needs to be done before it can be definitely established that the infra-red is more injurious to plant tissue than the visible region when compared on an equal energy basis.

The fact remains that such fruits and other similarly constructed plant organs absorb energy in both the visible and infra-red and are not designed to eliminate this energy rapidly by the evaporation of water from their surface. Such types of "sun scald" have been observed by Ramsey (18) on onions harvested and exposed to sunlight in crates and by Le Clerg (16) on honeydew melons exposed to sunlight when the leaves were killed by fungi. Cases have also been reported of sun scald on the trunks of young apple trees. There is the possibility that all such types of sun-scald injury may be produced by high radiation values in both the infra-red and visible regions.

REFERENCES

1. ARTHUR, JOHN M. Red pigment production in apples by means of artificial light sources. *Contrib. Boyce Thompson Inst.* **4**: 1-18. 1932.
2. ARTHUR, JOHN M. Artificial light and plant growth. *Agric. Eng.* **13**: 228-291. 1932. [*Also in Boyce Thompson Inst. Prof. Pap.* **1**(22): 212-221. 1932.]
3. ARTHUR, JOHN M., and W. D. STEWART. Transpiration of tobacco plants in relation to radiant energy in the visible and infra-red. *Contrib. Boyce Thompson Inst.* **5**: 483-501. 1933.
4. BROWN, H. T., and F. ESCOMBE. Researches on some of the physiological processes of green leaves with special reference to the interchange of energy between the leaf and its surroundings. *Proc. Roy. Soc. [London] B.* **76**: 29-111. 1905.
5. BURNS, G. R. Photosynthesis in various portions of the spectrum. *Plant Physiol.* **8**: 247-262. 1933.
6. CLUM, HAROLD H. The effect of transpiration and environmental factors on leaf temperatures. 1. Transpiration. *Amer. Jour. Bot.* **13**: 194-216. 1926.
7. CLUM, HAROLD H. The effect of transpiration and environmental factors on leaf temperatures. 2. Light intensity and the relation of transpiration to the thermal death point. *Amer. Jour. Bot.* **13**: 217-230. 1926.
8. COBLENTZ, W. W. The diffuse reflecting power of various substances. U. S. Bur. Stand. Bull. 196. 1913.
9. COBLENTZ, W. W., M. J. DORCAS, and C. W. HUGHES. Radiometric measurements on the carbon arc and other light sources used in phototherapy. U. S. Bur. Stand. Tech. Pap. 539. 1926.
10. CURTIS, O. F. What is the significance of transpiration? *Science* **63**: 267-271. 1926.
11. FORSYTHE, W. E., and E. M. WATSON. The tungsten lamp. *Jour. Franklin Inst.* **213**: 623-637. 1932.
12. GULIK, D. VAN. Über das Absorptionsspektrum des Chlorophylls. II. *Annalen Physik.* 4 Ser. **46**: 147-156. 1915.
13. GUTHRIE, JOHN D. Effect of environmental conditions on the chloroplast pigments. *Amer. Jour. Bot.* **16**: 716-746. 1929. (*Also in Contrib. Boyce Thompson Inst.* **2**: 220-250. 1929.)
14. JOHNSTON, EARL S. The functions of radiation in the physiology of plants. 2. Some effects of near infra-red radiation on plants. *Smithsonian Misc. Coll.* **87**(14): 1932.

15. KARRER, ENOCH. The luminous efficiency of the radiation of the electric arc. Jour. Franklin Inst. **182**: 538. 1916.
16. LECLERG, E. L. The relation of leaf blight to sun scald of honeydew melons. Phytopath. **21**: 97-98. 1931.
17. LUNDEGÅRDH, HENRIK. Der Temperaturfaktor bei Kohlensäureassimilation und Atmung. Biochem. Zeitsch. **154**: 195-234. 1924.
18. RAMSEY, G. B. Blemishes and discolorations caused by sunlight. Blemishes and discolorations of market onions. U. S. Dept. Agr. Circ. 135. 2-4. 1930.
19. SAYRE, J. D. The development of chlorophyll in seedlings in different ranges of wave lengths of light. Plant Physiol. **3**: 71-77. 1928.
20. SAYRE, J. D. Opening of stomata in different ranges of wave lengths of light. Plant Physiol. **4**: 323-328. 1929.
21. URSPRUNG, A. Über die Absorptionskurve des grünen Farbstoffes lebender Blätter. Ber. Deutsch. Botan. Ges. **36**: 73-85. 1918.

Manuscript received by the editor January, 1934.

XXVI

THE EFFECT OF ULTRA-VIOLET RADIATION UPON SEED PLANTS

H. W. POPP AND F. BROWN

Department of Botany, The Pennsylvania State College, State College, Pa.

Introduction. The effect upon seed germination and early growth of seedlings: Earlier investigations—More recent investigations—Summary. General studies on the effect upon more mature plants: Introduction—Injurious effects of short-wave ultra-violet radiation—Plants grown in daylight from which the ultra-violet portion was removed. Plants grown in daylight with additional short daily irradiation from a mercury-vapor lamp—Plants grown exclusively under artificial illumination—Plants grown under special ultra-violet transmitting glasses—General summary. Other relations to seed plants: Introduction—Absorption and reflection of ultra-violet radiation by plant tissues—Ultra-violet radiation and fluorescence of plant parts—Effects of ultra-violet radiation upon anatomical structure and flower formation—Ultra-violet radiation and the formation of chlorophyll and anthocyanin—Concluding remarks. References.

INTRODUCTION

In trying to arrive at a definite understanding of the effect of ultra-violet radiation upon plants one is immediately confronted by the fact that few experiments have been conducted in which ultra-violet alone was the causative variable. There is consequently little agreement among the investigators. Furthermore, the beneficial effects of ultra-violet on the animal organism have, in recent years, encouraged the attempt to demonstrate similar effects on plants, with the result that a great number of short experiments have been reported in which the lack of adequate controls has rendered the conclusions of doubtful value. In view of these facts the best that can be done in a review of this kind is to point out the claims of the various investigators and to evaluate them as far as possible on the basis of the merits and defects of their methods. The discussion which follows is subdivided according to the nature of the work reported.

THE EFFECT OF ULTRA-VIOLET RADIATION UPON SEED GERMINATION AND EARLY GROWTH OF SEEDLINGS

EARLIER INVESTIGATIONS

Before 1921 very few investigations had been carried out on the effects of ultra-violet radiation upon seed germination and early growth of seedlings. Carl (9) had stated that ultra-violet rays from a mercury-vapor lamp were detrimental to seed germination and the early growth

of plants. Raybaud (75, 76), on the other hand, had reported that the rate of germination of certain seeds was increased by such radiation, but that the seedlings were injured and died soon after emerging from the seed coats. Schanz (89) had found that seeds did not sprout so readily in daylight containing ultra-violet radiation as in daylight from which this radiation was screened out.

In 1921 Popp (69, 70) carried out a more detailed investigation of this subject. In a series of experiments upon various types of seeds, including foxglove, tobacco, mustard, corn, Canada field peas, lupine, and sunflower, he made numerous tests using the mercury arc in quartz as the only source of radiation. In some cases it was used unscreened and in others screened by various filters. The length of exposure ranged from a total of 1 to 2 up to 6 to 10 hr. per day for several days. The ranges of radiation reaching the experimental plants were indicated by spectrograms. From 50 to 100 seeds were used in each test with a corresponding number of controls, involving a total of about 5000 seeds. Plants were compared which had received approximately only the region 4200 to 3200 Å plus some infra-red, only the visible and infra-red plus the ultra-violet down to about 3000 Å and the visible and infra-red plus the ultra-violet down to about 2000 Å. Intensity differences under the various experimental conditions were not recorded because instruments for measuring these were not available.

The experiments indicated that exposures of dry seeds to the entire radiation of a quartz mercury arc for as long as 188 hr. had no effect on later germination and growth and that exposures of less than 2 hr. of soaked seeds that had not yet begun to sprout had no effect on later germination and growth. This was explained as probably due to the failure of the short injurious rays to penetrate sufficiently to be effective. Longer exposures of soaked seeds were injurious, and wave-lengths below 3000 Å were particularly harmful. No differences in rate of germination were noted in seeds grown in the dark, in the radiation of the lamp from which the ultra-violet was screened off, or under the lamp from which only the ultra-violet below about 3000 Å was screened off. If, however, the principal radiation (aside from infra-red) that the seeds received was ultra-violet of the approximate region 4000 to 3000 Å, injurious effects were indicated, more upon the seedlings after germination than upon the rate of germination, but these effects were probably chiefly caused by the absence of sufficient light for growth. Seedlings grown with the unscreened lamp as the only source of radiation never developed beyond the stage that would result from food stored in the seeds. This, plus the fact that starch tests were negative on mature geranium leaves which had been irradiated, was thought to be an indication that food synthesis is slight under the radiation of the unscreened lamp.

From 1921 to 1927 the reports of Sibia (104), Russell and Russell (84), Dane (14), and Ritson (Delf, Ritson, and Westbrook, 21) all indicated only injurious effects of the unscreened mercury-vapor arc.

MORE RECENT INVESTIGATIONS

Since 1927, in addition to reports indicating only injurious or indifferent effects of ultra-violet on seeds and seedlings, numerous papers have appeared in which an apparent effort has been made to demonstrate beneficial or "stimulating" effects of the ultra-violet.

Sheard with Higgins and Foster published a number of papers on the effect of "general" and "selective" irradiation upon plants. Four of these (Sheard and Higgins, 95, 96; Sheard, Higgins, and Foster, 97; Higgins and Sheard, 39) deal with germination of seeds and early growth of seedlings. Although the conclusions of these authors have been repeatedly referred to as though they were established facts, a careful examination of the experimental procedure, the results obtained, and the complete lack of data in some instances, reveals the unsoundness of these conclusions. For a more detailed criticism of this work the reader is referred to Popp and Brown (74, pages 163-165).

Another good illustration of the type of work that has been reported so often since possible stimulating effects of ultra-violet on plants have been sought is seen in Valentin's experiments (119) with Ultravit glass, a German product, which transmits all wave-lengths of daylight ultra-violet. He compared school children, various chemicals, and the germination and growth of plants in two schoolrooms having Ultravit glass windows, with those in two schoolrooms having ordinary glass windows. Corn, oats, beans, and peas were put in each schoolroom, eight seeds per room. These were planted in flower pots equally deep in the soil. ("Die Samen wurden gleichmässig tief in die Erde gebracht".) Because the seedlings in the pots behind Ultravit glass appeared above ground sooner than those behind window glass, the conclusion of the author was that the earlier appearance of the one set of seedlings was due to stimulation of germination by the ultra-violet transmitted by Ultravit glass and not by window glass. It is difficult to understand how any ultra-violet could possibly have reached seeds buried in soil. Further growth of the seedlings was somewhat better behind Ultravit glass than behind window glass.

While it is obvious that results of this type cannot legitimately be attributed to ultra-violet, Valentin's work, like that of Sheard and Higgins, has been quoted by later investigators in support of the thesis that ultra-violet radiation is "stimulating" to plants. It cannot be overemphasized that in the reading of reports of this type it is extremely important to examine carefully the *methods* of the investigators and not merely their summaries and conclusions.

From brief reports in *Gardeners' Chronicle* for 1927 and 1928 by Maddock (49), Russell (83), and the Kew Gardens (42) it appears, in general, that better results were obtained in houses covered with the English vita glass, which also transmits all wave-lengths of daylight ultra-violet, than in houses covered with ordinary window glass, which transmits only down to about 3130 Å. The source of radiation in these experiments was daylight only. Russell states that seeds and seedlings when screened with vita glass germinated earlier and showed taller and sturdier growth than did those under ordinary glass, but no definite data are given in his report. In the Kew Gardens report it is stated, regarding germination that "the first lap of the race between two sets of seeds and plants . . . has ended in victory by 24 hours for those grown under the new glass which admits the ultra-violet rays of the sun." The mistake made in all these papers is that of attributing the results to one variable, ultra-violet, when many other variables such as temperature, total-radiation intensity, visible radiation, and infra-red radiation, also existed.

Jacobi (40), after giving an extensive review of literature dealing with general effects of ultra-violet radiation, presents the results of his own experiments, some of which were concerned with seed germination. Radish, mustard, and lettuce seeds were selected for this work because they were thought to give better germination in the dark than in the light. A mercury-vapor lamp was used as the source of radiation. By the use of glass and solution screens all other regions of the spectrum were eliminated except the region between 3000 and 4000 Å. When dry seeds were exposed to this region for periods of 8, 16, 24, and 32 hr., no marked effect was produced on germination except that the mustard irradiated 24 hr. and the lettuce irradiated 32 hr. seemed to be furthered in growth after two days. Soaked seeds, on the other hand, irradiated for 2, 4, 6, and 8 hr. were reported to give a somewhat higher rate of germination. Exposures of soaked seeds for 10 hr. reduced the rate of germination. Seeds irradiated after the emergence of the radicle were unaffected by irradiations of 2, 4, 6, 8, or 10 hr.

An examination of the data in which favorable effects of the radiation seem to have occurred shows wide variations and fluctuations in the rate of germination of irradiated plants as compared with controls. For example, after 66 hr. the average percentage germination of lettuce irradiated for 2 hr. was 65.5 while that of the control was 63.75 per cent, but this same seed irradiated for 4 hr. gave 63.5 per cent germination in the same time, while the control gave 68.5 per cent. Furthermore, there is no consistent correlation between time of irradiation and effect. In one instance the 2-hr. exposure gave the highest rate; in another the 6-hr. one; in still another, the 8-hr. one. While in many cases the controls were somewhat behind the irradiated plants in rate of germina-

tion, fluctuations are so great that it would hardly be justifiable to attribute this to a stimulating effect of the region between 3000 and 4000 Å.

Mezzadrolì and Vareton (61, 62), Popoff (68), and Malhotra (50) also claim to have obtained favorable effects on germination and early seedling growth by means of ultra-violet radiation. In all cases the conclusions do not seem justifiable from the experimental data presented. For a more detailed criticism of their work the reader is referred to Popp and Brown (74, pages 167-168).

One of the most recent papers in which stimulation of early development of seeds is claimed is that of Masure (55). He has watched the behavior for 4 days of pea seeds kept in the dark after irradiation for various lengths of time with a mercury-vapor arc in quartz through a Corning G586AW screen. The range of this filter was given as 3334 to 3690 Å with a maximum transmission in the region 3650 Å.

In the summary of the paper only the possible demonstration of stimulation is mentioned, although earlier in the paper the author gives data which he himself states as indicating lack of stimulation. For instance, under no conditions of exposure in which the rate of germination was recorded did the irradiation of dry or soaked seeds influence in any significant degree the rate of germination. As stated by the author, "The results obtained allow only one conclusion to be drawn, namely, that raying has no marked effect on the rate of germination." Moreover, the data including average hypocotyl lengths of seedlings subjected to statistical analyses "do not indicate that the raying had a distinctly significant effect on the seeds."

The author's statistically significant figures indicating stimulation were obtained by comparing frequency distributions of root growth of seedlings of related pairs of lots of rayed and control populations. In this comparison the frequency-distribution curves for a treated and a corresponding control lot were plotted on the same sheet of graph paper, and a comparison made of the shift of the treated relative to the control population. By thus abandoning "average growth values" as masking the effect of raying and resorting to statistically analyzed frequency-distribution curves of root growth, he has obtained significant figures in favor of raying; that is, the percentage number of seedlings of rayed lots growing as fast as the fastest third of control lots was greater for rayed groups. While the statistical methods used seem to be satisfactory, the author has failed to give the data which would enable one to determine actual population distributions, upon which his only demonstration of stimulation is dependent. Furthermore, it cannot be overemphasized that while statistical analyses may show significant differences between test plants and controls, no statistical method in any sense indicates that one of a multiple of operating factors is the sole cause of the significant difference unless all of these factors are taken into account.

That variations between test plants and controls other than the presence or absence of ultra-violet radiation did occur in Masure's experiments is very probable. Certain measurements of the radiation used by Masure, made in our laboratories with a Kimball and Hobbs pyrheliumeter, indicate this. A sample of G586AW glass of the type used by Masure gave a total transmission of 10.71 per cent of the radiation from a Cooper Hewitt mercury-vapor arc. When a sample of Noviol "0" glass was interposed between the mercury arc and the G586AW screen, the transmission was 7.14 per cent of the energy incident on the Noviol "0" screen. Since the Noviol "0" glass transmits practically no ultra-violet, the 7.14 per cent transmission of these two glasses together must represent energy in the visible and infra-red, though chiefly in the infra-red, since the G586AW glass transmits only very feebly in a small part of the extreme visible red. Since the transmission of G586AW alone was only 10.71 per cent of the total energy of the mercury lamp and since when all ultra-violet was removed the transmission was still 7.14 per cent, it is obvious that the ultra-violet transmission of G586AW could not exceed 3.5 per cent. If the absorption of infra-red by the Noviol "0" glass were taken into account, this figure would be reduced still further. When we consider that a large part of the energy from a mercury arc is in the ultra-violet, and that when all this is eliminated the G586AW filter still transmits 66 per cent as much energy as it does when the ultra-violet is present, we must conclude that the G586AW screen transmits infra-red better than it transmits ultra-violet. If then we get differences in germination under this screen, it is hardly justifiable to attribute them to ultra-violet unless we have supplied our controls with an equal amount of infra-red. In any case we can hardly agree with the author that his experiments were conducted in the absence of all other radiations than ultra-violet. While it is possible that very small differences in the ultra-violet might be more effective than large differences in the infra-red, we cannot be certain of this until it has been demonstrated experimentally. If, as in the case of Masure's experiments, the differences are so slight as to require statistical manipulation to bring them out, we can reasonably doubt that the ultra-violet was very effective.

It might further be mentioned that some of the significant figures are based on averages of seedlings which received exposures ranging from 15 min. to 72 hr. This is not a very satisfactory grouping of data. In other cases individual series were analyzed. One would expect that if the ultra-violet is the effective agent in producing beneficial results, there would be some relation between time or intensity of exposure and the effect produced. Yet no relation is apparent.

Masure's experiments were conducted with seeds in closed dishes placed at distances of 8.5, 17.5, and 18 cm. from the mercury arc lamp. It is difficult to understand how a fan alone would prevent heating effects

from the lamp at such short distances, especially under periods of irradiation lasting several hours. In his lots *H* and *K* the seeds, in Petri dishes, were covered with G586AW glass and then brought to a distance of 8.5 cm. from the arc. Under these conditions heating effects must have been pronounced.

In view of all these considerations, it is obviously impossible to accept the author's conclusion that "ultra-violet radiation of $\lambda 3650 \text{ \AA}$, in the time and intensity employed and in the absence of all other radiations throughout the experiment, exerts a stimulative action on the subsequent rate of growth of the hypocotyl of pea seeds irradiated in the air-dry state."

As opposed to these papers reporting beneficial or "stimulating" effects, there have been since 1927 several papers in which only harmful or indifferent effects of ultra-violet on seeds and seedlings are indicated. Unscreened-arc experiments in general have yielded such results and have failed to show beneficial or "stimulating" effects.

Popp and Brown (72, 73, 74) have over a period of years carried out experiments on seed germination and early growth of seedlings using chiefly turnip but also radish, cucumber, pigweed, and curled dock. Many thousands of seeds have been used in these experiments. No less than 50 seeds per culture were ever used in any test. A number of different series of experiments have been completed. The seeds were usually germinated on moist filter paper and cotton and kept, except for short daily exposures to the mercury-vapor arc, some in the dark, some in diffused light, and some in diffused light minus all ultra-violet. Irradiations were given with the unscreened arc and with the arc screened with various Corning filters. A special effort was made to provide adequate controls. The irradiations were usually given for 10 days when rapidly germinating seeds were used.

The outstanding results of these experiments have been (a) the marked and invariably injurious effect on seedlings of the radiation of the unscreened arc even for exposures as brief as $\frac{1}{2}$ min. per day, (b) the lessened injurious effect of the radiation through a Corex filter, and (c) the failure of any region of the ultra-violet studied to influence significantly the rate or the percentage of germination or to stimulate the growth of seedlings. It should be emphasized that *no significant stimulation was ever obtained when adequate controls were used*. The effects were recorded by general appearance of cultures, hypocotyl lengths, leaf measurements, and dry weights.

Cluzet and Kofman (11), Mezzadrolì and Vareton (62), and Pires de Lima (67), also report unfavorable or harmful effects on seeds and seedlings of ultra-violet radiation from unscreened mercury-vapor lamps. Detwiler (22) found that the region 2700 to 3200 \AA caused delayed germination and pronounced stunting of seedlings of *Ribes rotundifolium*.

Tinker (112) obtained indifferent results on rate of germination of vegetable seeds in frames with ordinary glass and special ultra-violet transmitting glasses when daylight was the source of radiation.

SUMMARY

Viewing collectively the experiments thus far carried out on the effect of ultra-violet radiation on seed germination and the early growth of seedlings, one observes that the only fact clearly demonstrated is the injurious effect of short-wave radiation, that below 2900 Å. While there is some indication that certain ranges of ultra-violet might be beneficial in one way or another, the results so far reported are far from conclusive, and the evidence from more carefully controlled experiments would indicate little or no effect of the longer wave-lengths, those from 2900 to 4000 Å.

GENERAL STUDIES ON THE EFFECT OF ULTRA-VIOLET RADIATION UPON MORE MATURE PLANTS

INTRODUCTION

The preceding paragraphs have been concerned with investigations dealing exclusively with the effects of ultra-violet radiation upon seed germination and the first stages of seedling growth. Numerous investigations dealing with effects on plants in more advanced stages of growth and on plants under observation for considerable periods of time have also been reported. In these, evidence for effects of ultra-violet has been given in terms of general appearance of the plant, necrosis, height measurements, number and size of leaves, time and degree of flowering and fruiting, fresh weight, dry weight, and ash content. In addition, stem diameter, pigment development, development of spines, hairs, etc., anatomical features, chemical composition, enzyme activity, and various other criteria have been used.

The experiments have been carried out in various ways. In some, the effects of single exposures or several exposures to a mercury-vapor arc have been noted. In others, plants have been grown for considerable periods in daylight from which all ultra-violet rays have been eliminated by appropriate screens. In others, plants have been grown for a number of weeks under ordinary greenhouse conditions with additional short daily irradiations from a mercury arc in quartz either unscreened or covered with one of several filters. In others, artificial illumination only has been used, in combination with various filters. In still others, plants grown in houses, frames or boxes with ordinary glass panes have been compared with plants under similar conditions except that the ordinary glass panes were replaced by one of a number of special ultra-violet transmitting glasses. The wide differences in the methods of procedure make it necessary to consider the results obtained under the various conditions separately.

INVESTIGATIONS DEALING PRINCIPALLY WITH INJURIOUS
EFFECTS OF SHORT-WAVE ULTRA-VIOLET RADIATION

Earlier works such as those of Siemens (105), Dehérain (19), Bailey (4, 5, 6), Bonnier (7), and Rowlee (82) with electric arc light, while not primarily concerned with ultra-violet, did demonstrate its destructive action. The works of Hertel (37, 38), Maquenne and Demoussy (51, 52, 53), Kluyver (43, 44), Stoklasa (108, 109, 110), Ursprung and Blum (118), and Martin and Westbrook (54) appeared later. These investigators all noted the superficial destructive action of the short-wave ultra-violet. This destructive action manifested itself in the discoloration, collapse, and death of outer layers of cells, the depth of the injury depending upon the intensity, quality, and duration of the irradiation as well as on the nature of the tissues themselves. Kluyver (45) emphasized for the first time that the destructive rays were not present to any appreciable extent in solar radiation.

More recently Arthur and Newell (3) have performed experiments to determine what region of the ultra-violet is most injurious and whether that region near 2900 \AA , the extreme limit for solar radiation, is injurious to plant tissue. Using a quartz mercury arc and a series of Corning filters which absorbed progressive increments of the extreme ultra-violet between wave lengths 2000 and 2900 \AA , they noted the time necessary to produce marked injury on young tomato plants. Spectrograms and transmission curves, after continued use of the filters, were given so that the nature and amount of ultra-violet actually reaching the plants were definitely known. In addition, the total radiant energy reaching the plants through the various screens was measured by a Weather Bureau type pyrheliometer. Not more than 6 per cent variation was found to occur. Provisions were made for maintaining the constancy of the radiation of the mercury arc. The filters used were found not to solarize. Hence these experiments were performed under carefully controlled and relatively definitely known conditions of radiation.

The results showed that the time of exposure to the arc necessary to cause marked injury increased rapidly as more and more of the extreme ultra-violet component was cut off from the plants. By means of a quartz concentrating lens which increased the intensity three-fold it was also shown that apparently the time of exposure necessary to cause marked injury with a given quality of radiation is approximately inversely proportional to the incident energy. The injury produced was found not to be cumulative. That is, a plant but slightly injured by a single irradiation of a given duration through a certain filter received little further injury when irradiated through that same filter each day for several weeks for that same length of time. However, since new tissue

is continually forming as the plant grows, the total injurious effect produced on a plant was much greater when it was exposed often than otherwise. No marked beneficial effects were observed in any of these experiments. Nor was any injury produced within the extreme limits of wave-lengths present in solar radiation except under conditions which never occur in nature, namely, irradiation through a concentrating lens and a screen transmitting faintly to 2890 Å for 16½ hr. Injury did result, however, from wave-lengths but slightly shorter than those occurring in solar radiation.

These carefully conducted experiments confirm once again, and more accurately than previous experiments had, the results of earlier workers who have obtained injurious effects with short-wave ultra-violet radiation.

That the injurious effects of ultra-violet radiation are only temporary has been emphasized by Sibilina (104), Jacobi (40), Popp and Brown (73), Arthur and Newell (3), and Detwiler (22) who found that temporary effects on general appearance, color, size, general vigor, and weight disappeared when the injurious irradiations ceased, the length of time necessary for this being dependent upon the degree of injury, unless the injury was too severe, in which case the plants died.

Recently Fuller (30) has concluded from an experiment with 12 tomato plants per culture, and three cultures that the injurious effects of the open arc at short distances are due in considerable degree to infra-red radiation from the arc. Unfortunately, the author has worked with relatively uncontrolled conditions with regard to the radiations under consideration. He assumed that interposing a 1.5-cm. quartz water cell between the mercury arc and the plants caused no diminution in the intensity of the ultra-violet reaching the plants as compared with the unscreened lamp. That this is not true is indicated by an examination of the coefficients of absorption of water in the ultra-violet as given in the International Critical Tables. In addition, measurements made in our laboratories with a Westinghouse P.E. ultra-violet meter indicate that the ultra-violet intensity is cut down 25 per cent in passing through such a cell. Furthermore, the shorter the wave-lengths the greater is the absorption. Thus the destructive radiation is reduced much more than the longer, less destructive radiation. Obviously the diminished injury by irradiation through the water cell cannot be assumed to be due merely to the elimination of infra-red. The possible injurious effect of infra-red radiation of high intensity is by no means denied, but Fuller's experiments do in no way disclose that the injurious effects indicated for short-wave ultra-violet by the more accurately controlled experiments of previous investigators are without foundation. If Fuller actually wished to demonstrate injurious effects of infra-red, it is difficult to understand why he did not expose some plants to the infra-red in the absence of all ultra-violet.

INVESTIGATIONS DEALING WITH PLANTS GROWN IN DAYLIGHT FROM WHICH
THE ULTRA-VIOLET PORTION WAS REMOVED

Schanz (89) concluded that the elimination of the ultra-violet was beneficial to plants and recommended Euphos glass, which excludes ultra-violet, for greenhouses. His failure to take into consideration light-intensity differences makes it doubtful whether his results were really quality effects.

Popp (71) in 1925 conducted experiments at the Boyce Thompson Institute. Here for the first time seed plants were grown in light of various ranges of wave-lengths under controlled and stated conditions, particularly with regard to light intensity and quality. When only the ultra-violet portion of solar radiation was removed by a Noviol "0" screen of the Corning Glass Works without reducing the total intensity of the radiation over that of the controls, no significant effects were produced on plants as evidenced by general appearance, development of pigments, rate of growth, time and amount of flowering and fruiting, fresh and dry weights, amount of total carbohydrates, starch content, total and soluble nitrogen, and some of the higher organic compounds. Any indications given were in favor of the elimination of the ultra-violet. If, however, the blue end of the visible spectrum was removed with the ultra-violet, then decidedly abnormal plants resulted.

The experiments of Shirley (102) have indicated that the blue-violet end of the solar spectrum is more efficient in dry-weight production than the red end, when light intensities are uniformly 10 per cent of that outside. The removal of the ultra-violet and of some violet, however, caused no very significant decrease in efficiency, which is to be expected when we consider the small percentage of total radiation in this region.

Jacobi (40) attempted to determine whether the formative effects of ultra-violet radiation such as dwarfing, hairiness, thicker and smaller leaves, brighter colored flowers, etc., as claimed by Schanz (88), were really ultra-violet effects or whether they were light-intensity effects. He grew plants under Uviol, an ultra-violet transmitting glass, and Euphos, an ultra-violet absorbing glass, under solar radiation, and then sought to confirm his results as quality effects by performing laboratory experiments with artificial illumination in which an attempt was made to equalize intensities. He concluded with Schanz that the dwarfing effects were quality effects caused by ultra-violet radiation. He went still further and determined fresh and dry weights of his laboratory plants. Fresh weights came out in favor of Euphos glass, and dry weights in favor of Uviol glass, which was thought to be an indication that ultra-violet favors dry-weight production. However, the fact that fresh weights came out in favor of the Euphos glass, is an indication that one

might justly be suspicious that intensity differences in radiation and possibly a greater percentage reduction in the whole blue-violet end of the spectrum under Euphos glass were in operation. Unfortunately, there are no figures given of the actual intensities reaching the experimental plants in that portion of the work in which the attempt was made to equalize intensities. It might be noted that Senn (93) has attributed dwarfing in alpine regions to greater light intensity there, but he gave quality no consideration.

The experiments seem to indicate that at low altitudes the elimination of solar ultra-violet alone has relatively slight if any influence on the plant. At higher altitudes, where solar ultra-violet is more intense, or under artificial radiation rich in that portion of ultra-violet present in sunlight, there are indications of possible formative effects of ultra-violet, although these have not been clearly separated from intensity effects in the visible, particularly in the blue-violet region. Shaw (94), and later Popp (71), have emphasized the significance of the blue end in relation to configuration of the plant.

Simon (106) in a recent semipopular account of the nutrition of cultivated plants mentions incidentally an experiment of his with Euphos glass of the type used by Schanz. Cultures of garden plants under this glass were said to give, under otherwise similar conditions of environment and nutritional conditions, increased yields up to 50 per cent over plants grown under ordinary glass. The author, however, gives the impression that he was of the opinion that Euphos glass transmits ultra-violet better than ordinary glass does. If it was, as stated by the author, the same glass as was used by Schanz, it *eliminated* the ultra-violet. An accurate statement of the conditions of the experiment is not given.

INVESTIGATIONS DEALING WITH PLANTS GROWN IN DAYLIGHT WITH ADDITIONAL SHORT DAILY IRRADIATION FROM A MERCURY-VAPOR LAMP

An examination of Tsuji's (117) short preliminary paper in the Louisiana Planter would convince any critical observer of the inconclusiveness of his extravagant claims. The paper is mentioned here merely because it has been referred to in later reports.

Delf, Ritson, and Westbrook (20, 21) attempted one of the first studies of the effects of short daily exposures of more mature plants to the radiation of an unscreened mercury arc. Young plants of *Arachis*, *Voandezia*, and *Trifolium* exposed at various distances for short periods up to 10 min. per day were stunted, the epidermis of the leaves collapsed, and leaf mesophyll was less differentiated and more compact than in the controls. All of the irradiated plants died after the conclusion of the experiment. Of 10 controls left, 5 were irradiated for one month for 30 sec. per day at a distance of 8 ft. Two months later the irradiated

plants were larger and more vigorous than the controls. As there were just 5 of these plants, the results were considered only "suggestive." They were never repeated. Harmful effects were obtained in various other experiments and were more marked on plants given shorter day-light illumination per day than on those given longer periods in the light.

Eltinge (25) has made observations on rooted cuttings and young seedlings of plants grown for a number of weeks under ordinary greenhouse conditions with additional daily irradiations from a mercury-vapor lamp at distances of 50 and 100 in. Plants were exposed to the unscreened lamp, to the lamp screened by vita glass which was said to transmit down to 2890 Å, or to the lamp screened by quartzlite glass which was said to transmit down to 3130 Å. The irradiations were given by the incremental method, that is, for a period of $1\frac{1}{2}$ min. the first day and for periods increasing by $1\frac{1}{2}$ min. each day, on succeeding days.

While a considerable total number of plants was used, there were too many different species under too many different conditions so that generally no more than 6 to 10 individuals of a given species were given a similar treatment. Average figures recorded in tables, therefore, are computed from data on 6 to 10 plants grown under variable environmental conditions for from four to eight weeks. While all of her beneficial results were attributed to ultra-violet radiation, she had no controls to eliminate the possibility of visible, infra-red, temperature, and other effects of the lamp, since her so-called controls received no irradiation whatsoever from the lamp. Furthermore, she made no measurement of the quality or intensity of ultra-violet reaching her plants under the various conditions used.

The only consistent result of treatments was injury by the unscreened arc to all plants used. Individual groups of plants irradiated through vita glass or quartzlite glass did prove superior to nonirradiated plants in a number of cases, but the differences were often slight and no one type of glass gave uniformly better results. The superiority expressed itself differently in almost every set of plants in which it appeared. It might be greater height, greater thickness of stem, larger leaves, greater number of leaves, greater average rate of growth, greater rate of growth during the last days or during the last weeks of the experiment, earlier flowering, or better color of plant. There were various combinations of these features. The same treatment caused stimulation in one respect and retardation in another. For instance, no type of irradiation proved superior to controls for *Raphanus* and *Nicotiana*. For *Bryophyllum* and *Phaseolus*, vita glass and a distance of 50 in. from the lamp proved best. For *Coleus*, vita glass and 100 in. was best. For *Zea Mays*, vita glass and a distance of 100 in., and quartzlite glass and 50 in. distance from the lamp gave equally superior results. For *Lactuca*, quartzlite glass and

50 in. distance from the lamp caused the most leaves to develop, but they were smaller than those of controls. Cultures under vita glass at 50 or 100 in. had fewer leaves than those under quartzlite at 50 in., but more and slightly larger leaves than control cultures. For *Cucumis*, vita glass and 50 in. distance proved superior for stem elongation, but the control plants had more leaves. For *Ipomoea* quartzlite and 100 in. distance proved best for stem growth, but quartzlite and 50 in. were equally as good as quartzlite and 100 in. for leaf number, and both were better than controls. To illustrate the effect of the same irradiation treatment on three different sets of plants, the results of irradiation through vita glass at a distance of 50 in. may be cited. With *Zea Mays* at first the control plants grew taller, but during the last few days the rayed plants grew very rapidly and surpassed the controls. Rayed stalks were larger in diameter, rayed leaves outnumbered control leaves and were larger. With *Nicotiana*, however, the observations pointed toward a retardation of growth, though there was no evidence of burning. With *Ipomoea*, little difference was noted between rayed and control plants, although the rayed plants had more leaves.

Such results point far more likely to differences resulting from inherent variations of the plants themselves coupled with environmental variations of one type or another not taken into account. Certainly we should hesitate to attribute such varied effects solely to one variable under the conditions used in her experiments. Miss Eltinge's conclusion that "each plant has its own ultra-violet requirement for best growth which can be determined only by experiment" rests upon the assumption that the ultra-violet was the only variable in the test plants as compared with the controls. This obviously was not the case. So long as plants can be grown from seed to seed in the total absence of ultra-violet radiation and without showing any marked injury or any difference from plants receiving such radiation, it is doubtful whether we can legitimately speak of "ultra-violet requirement of plants."

Another series of experiments from the laboratory in which Miss Eltinge worked has been reported by Fuller (28, 29; Wynd and Fuller, 126). In many respects his methods resemble Miss Eltinge's except that Fuller restricted his work to tomato and cucumber plants, both of which he claims were decidedly "stimulated" by ultra-violet. This stimulation, according to the author, manifested itself in increased height, greater number of leaves, greater fresh weight and dry weight, and increased ash content and calcium content of treated plants over controls. The results of the major experiment were statistically analyzed, but unfortunately the author did not take into account, in this analysis, the fact that the conditions under which his test plants were grown varied over those of the controls, not only in the quality of ultra-violet they received and to which all results are attributed, but also in intensity

of ultra-violet, quality and intensity of visible and infra-red, presence of ozone, etc. Consequently his statistical analyses are not significant as indicating ultra-violet effects. Since he made no attempt to equalize these other conditions or to vary only the ultra-violet in his test plants as compared with the controls, he is hardly justified in assuming that any differences occurring in the test plants can be attributed wholly to ultra-violet. Furthermore, the differences between test plants and controls were often very slight and not always consistent, nor was there sufficient repetition of the experiments to justify any very definite conclusions being safely drawn. A more detailed discussion of Fuller's work is given by Popp and Brown (74, pages 179-183).

In a recent paper by Stewart and Arthur (107) it is claimed that ultra-violet radiation between 2900 and 3130 Å under certain conditions increases the calcium and phosphorus content of certain plants. Higher total light intensity may bring about the same result. It is believed that the radiation exerts its influence indirectly by the activation of ergosterol in the tissues of the plant.

Popp and Brown in addition to previously reported experiments have carried out five series with buckwheat. In two of these, 2-min. daily exposures to radiations from a mercury arc were given for 10 days; in the other two, ½-hr. daily irradiations were given. In one 2-min. series and one ½-hr. series the seeds were planted in soil and the first irradiation given when the seedlings were several inches high. In the other two series the seeds were placed on moist filter paper and cotton and irradiated for the first time 3 days later, that is, after the seeds were well germinated. Fifty seeds per culture were used. Exposures were given to the open arc, to the arc screened by Corex glass, by window glass, by Noviol "0" glass, and by G586A glass. In addition one culture was kept in diffused light with no irradiation, and one was exposed to the ozone only of the lamp. No favorable effects of the ultra-violet used in these experiments were obtained. The injurious effect of the unscreened arc was again manifested.

INVESTIGATIONS DEALING WITH PLANTS GROWN EXCLUSIVELY UNDER ARTIFICIAL ILLUMINATION

Withrow and Benedict's experiment (123) was unique in that they grew tomato and *Coleus* plants from seed for a period of three months under artificial illumination as transmitted by various cellophane filters. There was an attempt to determine whether the region 2900 to 3130 Å—that region said to be of such importance to animal life—was essential for optimum conditions of plant growth. They state that others have failed to obtain stimulation either because they did not have present a sufficient intensity of the rays 2900 to 3130 Å, if daylight was the source of radiation, or that in addition to a sufficient intensity of the rays 2900 to

3130 Å there were also present some of the shorter lethal rays, if the mercury arc was the source of radiation. In the use of artificial radiation they had a controlled light source with considerable intensity in the ultra-violet region. They used cellophane filters especially developed for the experiment (Withrow, 122) the transmission curves of which showed sharp cut-offs at the desired wave-lengths, a quality said not to be possessed by many glass filters which have been used. Their results indicated to them that "the removal of the 2900 to 3100 Å ultra-violet region is detrimental to the growth of tomato and *Coleus* plants, and that the inclusion of a small amount of lethal radiation of shorter wave-length than 2900 Å is sufficient to mask the beneficial effect of the 2900 to 3100 Å region." This was indicated by the greater height and growth rate, greater internodal length, greater stem diameter, greater number and average area of leaves, and greater fresh and dry weights of those plants which received radiation in the region 2900 to 3100 Å, with no shorter ultra-violet present. The final statement in the paper, however, reads that "because of the limited number of plants used and the inadequate growth conditions, especially with regard to intensity of illumination, these results are offered simply as preliminary data, indicating the possible growth-promoting action of the 2900 to 3100 Å ultra-violet region."

Unfortunately the total light intensity was only about 30 foot-candles, an intensity so low that it resulted in etiolation of the plants. None of the plants, therefore, was normal, except the so-called controls which were kept in the diffused light of a window sill with a southern exposure. These "controls" were not used in any of the measurements, and justly so since they were under conditions totally different from those of all other plants. While the cellophane filters used in this experiment were said to be stable, they were also said to show slow deterioration under intense irradiation. No further indication is given of the degree of stability of the filters. No measurements of total energy under the various screens are given. Such measurements would have been of particular value since the illumination intensity was probably below the minimum for normal growth and hence small differences in the different compartments might have caused pronounced effects on the plants.

The data recorded represent for tomato comparisons of measurements on 2, 6, and 14 plants, respectively, and the 14 plants under supposedly identical conditions show average measurements per pot to be more variable than average measurements of plants under different conditions. The tomato data are obviously of little value. The *Coleus* data were obtained by picking out three "representative" plants from each of five pots of *indefinite numbers of unthinned plants* under each condition. The photographs of these plants show decided crowding in the pots, which is very unfortunate, particularly when the illumination intensity was extremely low. It is difficult to understand why so many plants

were used per pot and on what basis any of the plants in any pot could be considered "representative." The photographs show that in any pot there was extremely wide variation in size of plants. Such data also are of limited value. There was no repetition of any of this work reported. While there is a possibility in these experiments of the favorable effect of the region 2900 to 3100 Å, the conditions under which the experiments were conducted were such as to offer very legitimate reason for doubt of the conclusions arrived at.

INVESTIGATIONS DEALING WITH PLANTS GROWN UNDER SPECIAL ULTRA-VIOLET TRANSMITTING GLASSES

Since the region 2900 to 3130 Å—that region of the solar ultra-violet which is not transmitted by ordinary window glass—has been emphasized as necessary for the normal development and health of higher animals, a series of special ultra-violet transmitting glasses has been developed and put on the market. Various Corning glasses of this country and vita glass of England are among these. There are also numerous German glasses known by various trade names, such as Uviol glass made by Schott and Genassen of Jena, U-glass of Dresden, ultra-violet glass of Berlin, Ufau, Ultra, Brepfos, Ultravit, Sendlinger, Bios, and Sanalux glasses. Probably the Jena glassworks of Germany antedates all others in manufacturing ultra-violet transmitting glasses, having made them as early as 1903. Their Uviol glass in comparison with five other German glasses was found to transmit farther down in the spectrum than any of the others and to transmit a higher percentage throughout in the ultra-violet than any of the others.

These new glasses differ from each other considerably in ultra-violet transmission and in addition some of them solarize, that is, lose a part of their transmission in the ultra-violet upon exposure to light (Arthur and Newell, 3; English, 26; Wood and Leathwood, 124, 125). This solarization is far more marked when the glass is used under a mercury arc than when used in ordinary sunlight. In a few cases glass substitutes have been tried, but these usually have not been found so satisfactory as glass screens. It is obvious that when one of these screens is used, the actual quality and intensity of the ultra-violet reaching the plants can be ascertained only by repeated definite measurements of transmission.

Unfortunately, not only is the ultra-violet transmission of these glasses different from that of ordinary glass, but so also is the visible, and in great degree the infra-red transmission. These features have been indicated by transmission curves of the glasses and by the temperature differences occurring under the two types of glasses. Any effects, therefore, obtained under one of these new glasses, cannot justifiably be said to be ultra-violet effects, but must be attributed to the difference in total transmission of the glasses used, other environmental conditions

being constant. Yet the majority of investigators who have used these new glasses have placed the emphasis almost exclusively on their relatively greater ultra-violet transmission.

Many of the experiments conducted with these new glasses have not been carefully controlled aside from radiation conditions, so that results are correspondingly inconclusive. The fact that a small number of plants was used in many cases is also unfortunate, and failure to repeat experiments still further reduces the value of results obtained, since very often those who have repeated their experiments were unable to duplicate their original results. Most of the experiments of this type have been carried out from a practical viewpoint by greenhouse keepers, horticulturists, and floriculturists with practical results rather than scientific data as the aim and purpose.

In this country one of the carefully performed experiments of this nature was carried out at the Boyce Thompson Institute (Arthur, 2). Several species of flowering plants were grown under Uviol glass which transmits 80 per cent at the extreme ultra-violet of sunlight, and no differences were observed in growth habit, time and amount of flowering, or amount of green tissue produced as compared with plants grown under ordinary greenhouse glass. "We have yet to find any distinct advantage to the plant in growing it under a glass which transmits the extreme ultra-violet region of sunlight."

Osmun (63, 64) obtained favorable results under vita glass for lettuce and radish one year, but during the next year continued experiments gave contradictory results. The first year, radishes under vita glass showed a gain of 71 per cent in weight of the entire plant and 124 per cent in weight of roots as compared with an equal number of plants under ordinary glass. Similarly lettuce gained 76 per cent in weight and formed more compact heads under vita glass. The next year radishes averaged 10 per cent less in weight under vita glass than those under ordinary glass in one test and 14 per cent more in another. Lettuce under ordinary glass this second year weighed 3 per cent more than that under vita glass. Obviously nothing concerning ultra-violet radiation can be concluded from these results.

Tottingham and Moore (115, 116), and Tottingham (114) have reported on some horticultural investigations at the Wisconsin Agricultural Experiment Station. In the principal paper (116) a small number of plants of 12 different species which had been under vita glass for a number of weeks was compared with plants similarly treated but grown under window glass. The comparisons involved the nature and amount of growth, dry weights, and partial chemical analyses. As stated by the authors, "The present investigation is concerned with the elimination of a small portion of ultra-violet (about 3100 to 2900 Å) in sunlight by the screening effect of common glass," but there is no mention in the

summary of any favorable results under vita glass being due to the region 2900 to 3100 Å alone. Favorable results mentioned for plants grown under vita glass are ascribed rather to "the more extensive irradiation under vita glass," and there is mentioned the desirability of separating infra-red and ultra-violet effects. They recognized the high transmission of vita glass in the infra-red. At the end of the paper they state that "the present investigation is hardly more than a limited survey" and that "for conclusive results each species tested would require further examination."

Regarding the interpretation of the differences found in plants under vita glass as compared with those under common glass it is evident that the authors attach great significance to slight differences in favor of vita glass, which have been obtained with small plant populations not grown under carefully controlled conditions and often not checked by repeated experiments.

The most consistent "compositional response" to vita glass was an increased percentage of lipids in the dry matter. In five out of 16 tests the ether extracts from plants under vita glass were either lower or no higher in lipids than were those under ordinary glass. The other 11 cases showed slightly higher percentages for plants under vita glass. In another paper (Tottingham, 114) a higher percentage of lipids for tomato plants under vita glass is again reported.

While these percentages are small, the fact that increases have been reported in a number of cases may indicate a vita glass effect. Certainly, however, from such experiments we are not justified in attributing this to effects of the region 2900 to 3100 Å alone.

Miss McCrea (56 to 59) has studied the growth of the plants and the medicinal potency of the tincture obtained from *Digitalis purpurea* grown, in the seedling stage, under vita glass and under common glass and then transplanted to the open. She states that "during the 6 to 8 weeks of exposure, treated plants clearly show an advantage over controls. They are larger, of darker green, and develop the second, third, and fourth pairs of leaves earlier than do the controls." These visible differences disappeared after the plants were grown in the open. When these plants were harvested, after having been grown in the open from about May 25th to late July or early August (first crop) or to mid-September (second crop) tinctures made from the dried, treated plants gave increased potency over those of controls to the extent of 11.66 per cent to 51.50 per cent. This increased potency was also found to be carried over to the second year in these plants. Any possible solarization of the glass she used failed to affect the results.

While her results are very interesting, she has not measured the radiation under the two kinds of glass and hence we are left in doubt as to how much of the effects noted can be attributed to ultra-violet.

Recently Leonard and Arthur (48) have reported on experiments which have been in progress for three years in which no significant differences in glucoside yield could be observed between digitalis plants grown under a glass having a higher ultra-violet transmission and those grown under ordinary window glass, whether the plants were kept until sampled in air-conditioned greenhouses or were set out after some months of such treatment into the open field.

In England there have been numerous reports on plants grown under the English vita glass including those of Russell (83), the Kew Gardens (42), Saleeby (86), H—— (35), Colman (12), Westfield College (121), Maddock (49), Thomson (111), Graham and Stewart (33), Tincker (112, 113), Pilkington (66), and Secrett (92). In Germany results of experiments on plants grown under the various German glasses of this type have been made by Kache and others (41), Dix (24), Herold (36), Reinhold alone and with others (77 to 79), Roeder (80), Grossman (34), and an anonymous author (1). A detailed review of these experiments is not necessary here inasmuch as the majority of them were ordinary greenhouse experiments without adequate controls and all of a very preliminary nature. As might be expected, there is no general agreement among them as to the results obtained.

In Sweden Lamprecht (47) has carried out one of the most careful investigations of this type. He has compared plants grown under Helasan glass which transmits about 50 per cent of the solar radiation from 2900 to 3100 Å, a somewhat higher percentage of ultra-violet than vita glass transmits, but not so high a percentage as Uviol glass transmits. The plants were carefully handled and spaced and environmental conditions made as uniform as possible. Great care was taken to have the thickness of glass panes comparable in the test and control houses in order that the intensity of radiation reaching the plants should not vary because of this factor. Relatively large numbers of plants, never less than 40, under each condition in each test were used, and each series of experiments was repeated several times. The results were treated statistically and probable errors taken into account. Fresh-weight and dry-weight percentages were determined and various chemical analyses made.

Six series of carrots were run with 46 to 122 experimental plants used in each series. In no case did the use of Helasan glass result in significantly increased fresh weight, dry weight, or any change in chemical composition. One series of parsnips and one of radishes, both root crops, as were the carrots, gave similar results. Two series of lettuce plants gave no significant differences in fresh or dry weights related to the type of glass used, but indicated a definite trend in dry weights in favor of Helasan glass. Two series of spinach, again a leaf crop, gave results similar to those of lettuce.

The conclusion regarding the effect of the ultra-violet portion of the solar spectrum as revealed by these experiments was that there was the

possibility of a certain small significance in the production of dry weight, but that definite establishment of this point could only come from much more carefully conducted experiments. For the practical horticulturist the author considered the glass of little value.

A review of the facts brought out by these reports in regard to evidence for ultra-violet effects by the use in greenhouses of special ultra-violet transmitting glasses reveals that out of 31 reports, unqualifiedly favorable results are reported in only 8 cases and the data for these are either not given or are of questionable value. The other articles report either conflicting results, results which could not be duplicated, very slightly favorable, or indifferent results. Of these at least 10 report the greater temperatures or heat effects under the special glasses. Several report more favorable results under them early in the spring, but not in the summer; a number report solarization effects of the glasses. The most carefully conducted experiments show nothing or very little in favor of the new glasses. Even were we to assume that all the beneficial effects reported were attributable to this factor, we should still have to hesitate to recommend the use of the special glasses for greenhouses because of the slight differences that have been found in even the most favorable reports.

GENERAL SUMMARY

In general, the evidence presented in this large group of papers on the effects of ultra-violet on more mature plants reveals only one point which seems to be clearly demonstrated, namely, that the short-wave ultra-violet, that from 2890 to 2000 Å is distinctly harmful. Even in very slight doses it has never satisfactorily been demonstrated to be beneficial. The degree of injury increases with decrease of wave-length, increase of intensity, and with greater ease of penetration. While we would not overlook the possibility of beneficial effects being demonstrated for the longer wave-lengths of ultra-violet when accurately controlled experiments are forthcoming, the evidence from the most accurately controlled experiments to date shows little if any outstanding stimulation or increased growth from this region. When we consider the low energy value of this region in daylight, the universal source of radiation for plants, and when in addition, it has clearly been demonstrated that many different kinds of plants can be grown from seed to seed in the total absence of all ultra-violet without exhibiting any very outstanding difference from plants receiving solar ultra-violet, we may legitimately doubt whether any very outstanding stimulation of growth will be demonstrated for this region in the future.

OTHER RELATIONS OF ULTRA-VIOLET RADIATION TO SEED PLANTS

INTRODUCTION

The effects of ultra-violet radiation on enzymes, vitamins, and other cell constituents, and on photosynthesis and respiration are considered

elsewhere in this monograph and hence have been omitted here. The relation of ultra-violet radiation to transpiration, sun scald, winter hardiness, tropisms, electric potentials, and currents in plants and other relations are not discussed because the evidence is too fragmentary. There remain to be considered briefly, absorption and reflection of ultra-violet by plant tissues and fluorescence of plant parts caused by ultra-violet. Although the effect of radiation on the histology of plants and its influence on plant pigments are considered elsewhere in this monograph, a few statements are made regarding the specific relation of ultra-violet radiation to these features.

ABSORPTION AND REFLECTION OF ULTRA-VIOLET RADIATION BY PLANT TISSUES

Of great importance in any consideration of the effect of ultra-violet radiation upon plants is the question of the degree of penetration of these rays into the various plant tissues, since only those rays which penetrate can be effective in producing results. Undoubtedly the facts that certain plants are more resistant than others to the harmful action of short rays, certain parts of a given plant more resistant than other parts of the same plant, and the same parts of a given plant more resistant at one stage of development than at another, have their explanation in part at least in differences in degree of penetrability and absorption of these injurious rays. Different degrees of penetrability may also explain some of the conflicting results of past experiments. Thus the shorter lethal ultra-violet regions are ineffective if they do not reach the plant parts under consideration. Furthermore, any beneficial rays would have to enter the cells before they could be effective. Different media vary considerably in their capacity to transmit radiation of various wave-lengths.

In earlier investigations the penetration of injurious rays only was considered, and the degree of penetration was known only indirectly by the degree of injury produced on the plant cell as a result of irradiation. Maquenne and Demoussy (51), Kluyver (43, 44), and Ursprung and Blum (118) noted the superficial action of ultra-violet radiation of short wave-lengths as indicated by the fact that only epidermal cells or those immediately beneath them were destroyed. They assumed that the harmful rays were absorbed by these external layers and failed to penetrate more deeply. Stoklasa (108) found that flowers were much more sensitive than leaves to short-wave ultra-violet, and that both leaves and flowers of hot-house plants were more sensitive than those of outdoor plants. Dangeard (16, 17) by noting various degrees of injury in different plants which had been irradiated assumed differences in degree of penetration of the harmful rays. He also thought that hairy leaves retarded penetration more than glaucous or smooth ones. Schroeter (90) thought that the thick cuticle of alpine plants protected them from the

destructive action of the short wave-lengths present in solar radiation. Köhler (46) using the cadmium line at 2750 Å showed that cuticularized, suberized, and lignified walls were not penetrated by waves of this length and explained the greater resistance of some leaves to ultra-violet on the basis of differences in the degree of penetration of the harmful rays. Schulze (91) by photomicrographs also demonstrated that the cuticle, epidermis, and xylem absorb strongly in the region of 2800 Å, while parenchyma, phloem, and young cambium are quite transparent to this region. He found strong absorption to occur in the middle lamella. He and Köhler showed that the nucleus absorbs strongly at wave-lengths of 2800 and 2750 Å, respectively. Dhéré and De Rogowski (23) found that pure chlorophyll was remarkably transparent to ultra-violet, but that the natural chlorophylls in ether solution had a common absorption band near the middle of the ultra-violet spectrum, which would be at about 3040 Å.

More recently Bucholtz (8), Gola (32), Metzner (60), and Shull and Lemon (103) have published their observations on this subject. Bucholtz noted that leaves of *Mnium* and the stamen hairs of *Tradescantia reflexa* were much more resistant to the lethal action of ultra-violet than bacteria and paramoecia, probably because of the greater opaqueness of the cells of higher plants. He used wave-lengths of the range 3654 to 2378 Å.

Gola's studies (32) were on the reflection and absorption of the region 3400 to 3800 Å by the flowers, leaves, and fruits of numerous plants. His results were determined by impressions made on photographic plates by the plants when photographed by means of radiation in this region of the spectrum. Flowers and leaves containing flavone groups were found to absorb this radiation. Flowers containing only carotinoid pigments reflected it. Waxy coverings on leaves and fruits made heavy impressions on the photographic plates. The reflecting capacities of the outer coverings of plants and the absorbing capacities of the flavone groups were looked upon as defense mechanisms of the plant against this type of radiation.

Metzner (60) also using long-wave ultra-violet (3500 to 4000 Å) determined photomicrographically the penetration of this region into various plant parts. The older work of this type was carried out with radiation of shorter wave-lengths not present in sunlight. His photographs showed that cellulose, hemicellulose, and silicified walls were relatively transparent to this region. The plasma and nucleus absorbed weakly. On the other hand, corky and cutinized walls, and lignified ones to a lesser extent, prevented penetration by this region. Particularly strong absorption occurred in the cell sap of the epidermis, guard cells, and mesophyll of many plants; this absorption was thought to be due to the presence of tannins and flavones and to be of biological significance.

Metzner could not determine from his results whether radiation which did not penetrate the sections examined was absorbed or reflected. Hence part of what he regarded as absorption may in reality have been reflected radiation.

Of significance in relation to the effect of ultra-violet radiation upon seed germination is the paper by Shull and Lemon (103), which deals with the penetration of various seed coats by the radiation of an unscreened quartz mercury arc. Results were determined by spectrograms. They found that, with a maximum duration of irradiation of 1 hr., only the longer ultra-violet rays penetrated seed coats, the lowest limit being indicated by a feeble line at 3120 Å and penetration of rays shorter than 3630 Å always being feeble. There was some variability in penetration shown by different species. Even in the same seed coat there was variation. Thus in the case of corn-grain membranes penetration was greatest on the embryo side. Wet coats differed little from dry ones as far as penetrability was concerned.

In the paper just referred to there is an actual demonstration of the reason, mentioned as a probability by Popp in 1921, for the failure of the short-wave ultra-violet to injure ungerminated seeds, namely, the failure of these rays to penetrate the seed coat. This paper also gives evidence which suggests that the region of ultra-violet used in Masure's investigation did actually penetrate the seed coats of his seeds.

It should be noted that no determinations of penetration to date have given percentage transmissions of various wave-lengths through seed coats or any other plant parts. In other words, we have only qualitative and no quantitative data.

ULTRA-VIOLET RADIATION AND FLUORESCENCE OF PLANT PARTS

The capacity of various parts of numerous different kinds of plants to exhibit fluorescence phenomena when exposed to ultra-violet radiation has been noted in several studies. Some suggestions have been made concerning the nature of the fluorescing substances and the significance of their distribution and capacity to fluoresce. No facts have been established to date, however.

Gentner (31), Mezzadrolì and Varetton (61), Foy (27), and Masure (55) all noted the fluorescence of germinating seeds in the presence of ultra-violet radiation of 3000 to 4000 Å. Gentner (31) has attempted to find out whether the nature of the fluorescence is specific enough that it may be used practically for seed testing, particularly for the differentiation between seed varieties and races. Foy (27) has used this method successfully in diagnosing various types of rye-grass in New Zealand. The annual Italian rye grass and some or all of the false perennial types exhibit a brilliant blue fluorescence while the true, normal, perennial rye grass reacts absolutely negatively.

Gola (32) found that green leaves exposed to 3400 to 3800 Å showed an intense fluorescence. Certain white flowers exhibited a similar phenomenon, which he thought might be due to the remains of traces of green plastids once present, or of their degradation products. He suggests that fluorescence is associated with lipoid-like substances.

Cecco (10) using Petri's method for isolating fluorescent substances from various parts of numerous plants on filter paper found also an abundance of a fluorescing substance in the green organs of plants, and in those parts capable of becoming green. She states that the presence of fluorescing substances in the assimilating tissues seems to constitute a normal condition of vital activity. She points out that there cannot be attributed to this fluorescence a protective function against solar radiation of short wave-length since there is no relation between the relative amount of the fluorescing substance present and the ability of the plant part to withstand radiation. The fluorescing substance was thought to be of the nature of a glucoside.

Vodrážka (120) noted the fluorescence in the cross sections of various woody stems when these were exposed to ultra-violet radiation, and thought that the causes of the fluorescences in *Robinia* were substances related to tannins. This hypothesis is similar to that of Cecco, in that Cecco found some tannic substances in her fluorescing extractions. The fluorescing substances were found regularly in certain parts of the pith, primary wood, heartwood, and sapwood.

EFFECTS OF ULTRA-VIOLET RADIATION UPON ANATOMICAL STRUCTURE AND FLOWER FORMATION

Since the penetration of the shorter ultra-violet rays is probably not very great, one would not expect them to have any considerable direct effect on the anatomical structure of plants except for the destructive action to the superficial cells. There is, of course, the possibility of chemical changes being brought about in the superficial layers which might in turn affect deeper lying cells, but we have no evidence for this. As for the longer, more penetrating, ultra-violet rays there is no evidence of their effectiveness in this field either.

Pfeiffer (65) reports that plants grown in daylight under Noviol "0" glass which cuts off practically all ultra-violet are less stocky, less sturdy, more watery, and weaker in vascular development than those grown under Corex glass which transmits all wave-lengths of solar ultra-violet.

From the fact that stem diameters, stem heights, fresh weights, dry weights, percentage of moisture, and chemical analyses of plants grown under similar conditions by Popp (71) showed no marked differences we should not expect to find marked internal anatomical differences. Such differences were not found by Popp. The difficulty in obtaining sufficient and comparable material for anatomical study under such conditions

renders anatomical differences found of doubtful significance unless they are very marked.

The effect of ultra-violet radiation alone on anatomical structure is still largely to be determined. Further discussion of anatomical effects will be found in the section of this monograph devoted to this topic (Buchholz, pages 829-840).

As early as the time of Sachs (85) and DeCandolle (18) ultra-violet has been said to influence favorably flower formation. Eltinge, Ballan, Westfield College reports, Michigan Station reports, and Totttingham and Moore have all suggested earlier or better flowering in certain cases as an ultra-violet effect, but it has already been noted that such effects were not consistently obtained and were usually associated with temperature or other differences when comparisons were made with control plants. Popp found that elimination of practically all ultra-violet had no effect on the time or amount of flowering of many of his plants. In some cases the earlier flowering plants were those from which practically all ultra-violet was screened off.

ULTRA-VIOLET RADIATION AND THE FORMATION OF CHLOROPHYLL AND ANTHOCYANIN

While Stoklasa (108, 109) noted that exposures not exceeding 2 hr. to wave-lengths 3000 to 5000 Å of a mercury are generally caused a rapid development of chlorophyll in etiolated plants, and that etiolated plants exposed to this region of sunlight became green more rapidly than those exposed to full sunlight, Dangeard (15) claimed that blue and violet light from a Nernst lamp seemed to have little influence on chlorophyll synthesis, and that the energy absorbed below 4900 Å was insufficient to bring it about. Sayre (87) has said that with sufficient energy value, chlorophyll develops in that region of the ultra-violet between 3000 and 4000 Å. In many reports a deeper green color of plants under one of the special ultra-violet transmitting glasses has been reported, but it should be noted that this is not necessarily an indication of greater chlorophyll development, as this appearance may be brought about by a more compact tissue, a broken down epidermal layer, lack of hairiness, etc. In addition, as has been indicated before, effects under these special glasses are not necessarily ultra-violet effects. Colla (13) found that chlorophyll developed in plants exposed to radiation of 3300 to 3900 Å, the amount being comparable to that produced in ordinary light of low intensity. In none of these cases has there been quantitative determination of chlorophyll.

Shirley (102) determined quantitatively the amount of chlorophyll developed using the method of Willstätter and Stoll as modified by Schertz. Plants grown under a blue glass transmitting the region between 3740 and 5850 Å under 10 per cent of the total intensity of

daylight often gave a higher concentration of chlorophyll than any other light qualities used under the same intensity. At the same time the chlorophyll concentration was usually lower under G34 glass, which transmits no radiations shorter than 5290 \AA . He found that "in all light qualities used the plants increased their chlorophyll concentration with decreasing intensity to a certain point." When plants, from which only the ultra-violet was removed under 65 per cent of the total intensity, were compared with those receiving the full spectrum of daylight under 68 per cent intensity, no significant difference in chlorophyll content was found in *Geum*, sunflower, or *Galinosoga*. This is the only investigation in which quantitative determinations of chlorophyll were made under various light qualities.

A relationship between ultra-violet radiation and the development or presence of anthocyanin and related compounds in plant cells has been suggested in a number of cases. Shibata, Kishida, and Nagai (98 to 101) found that the cell sap of epidermal and peripheral parenchymatous cells of the aerial parts of plants in general, commonly contained flavone derivatives. Furthermore, according to them, these compounds were limited almost exclusively to these parts of plants. They also noted that plants in sunny habitats contained greater amounts of flavones than those in shady places, and that alpine plants were richer in flavones than those in lower regions where the intensity of solar radiation was not so great as in alpine regions. In general, plants exposed to intense sunlight showed a greater development of flavones than those under lower intensities unless the plants were protected by some morphological feature such as a thick cuticle. Thus *Ficus elastica*, a tropical plant grown under strong light intensity, had leaves with a low amount of flavones, but these leaves had a thick cuticle. Rosenheim (81) thought that if the findings of Shibata, Kishida, and Nagai were true, then alpine plants grown at lower altitudes should not contain so much flavone as those grown in alpine regions. Using Edelweiss as an example he found that this plant actually did not develop so much flavone when grown at lower altitudes as when grown in the Alps.

Schanz (89) noted that much of the red color of red-leaved lettuce grown outdoors disappeared when the plants were placed under ordinary window glass which cut off most of the radiation below 3200 \AA , while all of it disappeared if wave-lengths shorter than 3880 \AA were eliminated. When young plants of *Celosia Thompsoni* with dark red leaves were placed in daylight under various screens the new leaves which formed were less red and more green the more the short wave-lengths were eliminated, and were completely green when wave-lengths shorter than 4200 \AA were removed. Red-beet leaves lost the red color in the absence of ultra-violet radiation, but the stems and petioles remained red.

These investigators have all attributed possible biological significance to the development and presence of these anthocyanins and flavones. One of the possible rôles suggested for these substances was that they absorb ultra-violet radiation and consequently protect deeper lying cells from its injurious effects. Metzner (60) found that the region 3500 to 4000 Å does not pass through cell sap which contains tannins and flavones. However, this hypothesis loses weight when it is remembered that ultra-violet radiation of the intensity and quality present in solar radiation has never been conclusively demonstrated to be injurious to plants. Such evidence as is available, as, for example, that of Arthur and Newell (3), indicates rather that ultra-violet of the intensity and quality present in daylight is not injurious.

One of the possible demonstrations of the injurious effects of solar ultra-violet is indicated by Schanz's experiment with the purple beech (89). While the experiment was not carried out with proper controls, it does indicate a possible destructive action of short-wave radiation on plants containing epidermal anthocyanin when they are first grown under conditions which prevent the development of this anthocyanin and later exposed to radiation containing ultra-violet. Schanz, having raised this purple beech under various screens, found that it lost its red anthocyanin color the more the short waves were cut off. He then transplanted one of the plants which had developed large green leaves lacking anthocyanin to the open where it was exposed to the full radiation of daylight. At the end of 14 days all of these green leaves were dead and the new ones that had developed were red in color. Schanz concluded that possibly the red anthocyanin acted as a screen here to protect the plants against ultra-violet radiation. Unfortunately plants that had already developed anthocyanin were not transplanted to the open in a similar manner. Furthermore, other species of plants containing a similar anthocyanin relationship were not injured when placed in the open. This situation might be cleared up if such plants as the purple beech were first grown under conditions in which anthocyanin fails to develop and then exposed to an artificial source of ultra-violet by the same method as was used by Arthur and Newell. Then at least we would be able to ascertain whether such plants were more sensitive to long-wave-length ultra-violet than ordinary plants.

Popp (69, 70) found that mustard seedlings grown continuously in the dark, or grown in the dark and exposed to the mercury arc from which the ultra-violet portion had been eliminated, formed anthocyanin. The fact that beet roots developed in the soil in the absence of all radiation are rich in anthocyanin is well known.

The experiments seem to indicate that anthocyanin formation is possibly favored by ultra-violet radiation, but ultra-violet effects have never been clearly separated from those of total radiation intensity or from blue-visible effects.

Further information concerning the effect of ultra-violet radiation on anthocyanin development is given in another paper (Arthur, Paper XXXV).

CONCLUDING REMARKS

In spite of the many publications on the subject, exact knowledge regarding the influence of ultra-violet radiation upon seed plants other than its destructive action is still to be ascertained. The interest in ultra-violet in recent years has been so widespread as to justify the accusation of some that the subject is a fad. It is to be hoped that the "fad" will not run its course before accurate information has been obtained. Needless to say, such information will not be forthcoming from experiments of short duration, carried out with a few plants under poorly controlled conditions such as have predominated in the work of the past.

Much of the present uncertainty of our knowledge of the effects of radiation upon plants rests upon the complexity of the problem itself. No other environmental factor is so variable or so difficult to control. The fact that plants require visible radiation for normal growth necessitates supplying them with this radiation. Sources of visible radiation usually contain also infra-red radiation. Consequently these factors must be considered and equalized in test cultures and controls when the effects of ultra-violet are to be studied. Total-radiation measurements, transmissions of screens, spectrograms of the radiation used, and the like, are in themselves insufficient to give a complete picture of the nature of the radiation reaching plants, although in many papers, even these variables are not given. Few, if any, authors have measured the total energy or the distribution of the energy in the ultra-violet to which results were attributed, to say nothing of the failure to equalize the radiant energy of other wave-lengths reaching the test plants as compared with the controls. While it is conceded that these measurements are difficult to make, it must also be admitted that so long as they remain unknown in an experiment the results cannot be attributed to ultra-violet any more than to any other operating variable.

In addition to the necessity of having a complete description of the radiation reaching plants it is no less important to know whether the plants or plant parts studied absorb selectively different portions of the spectrum and to what extent. Possible photochemical reactions in the plant may be greatly accelerated in a relatively narrow region of the spectrum that is strongly absorbed, whereas comparatively high intensities in a region that is feebly or not at all absorbed might be without effect.

REFERENCES

1. ANONYMOUS. Kulturversuche unter Glassorten, die ultra-violetten Strahlen durchlassen, Brephosglas und Ultravitglas. Veröffentl. Landwirtschaftsk. Rheinprov. n. s. 18: 49-50. 1930.

2. ARTHUR, J. M. Light and the green plant. *Sci. Monthly* **31**: 343-346. 1930.
3. ARTHUR, J. M., and J. M. NEWELL. The killing of plant tissue and the inactivation of tobacco mosaic virus by ultra-violet radiation. *Amer. Jour. Bot.* **16**: 338-353. 1929.
4. BAILEY, L. H. Some preliminary studies on the influence of the electric arc light upon greenhouse plants. *Cornell (New York) Agric. Exp. Sta. Bull.* **30**: 83-122. 1891.
5. BAILEY, L. H. Second report on electrohorticulture. *Cornell (New York) Agric. Exp. Sta. Bull.* **42**: 133-146. 1892.
6. BAILEY, L. H. Greenhouse notes for 1892-1893. Third report on electrohorticulture. *Cornell (New York) Agric. Exp. Sta. Bull.* **55**: 127-138. 1893.
7. BONNIER, G. Influence de la lumière électrique continuée sur la forme et la structure des plantes. *Rev. Gén. Bot.* **7**: 241, 289, 332, 409. 1895.
8. BUCHOLTZ, A. F. The effect of monochromatic ultraviolet light of measured intensities on behavior of plant cells. *Ann. Missouri Bot. Gard.* **18**: 489-508. 1931.
9. CARL, W. Über den Einfluss des Quecksilberdampflichtes auf die Keimung und das erste Wachstum von Pflanzen. *Beitr. Biol. Pflanz.* (Cohn's) **12**: 435-437. 1914.
10. CECCO, M. DE. Applicazione dei raggi ultravioletti alla ricerca di sostanze fluorescenti nelle piante in rapporto ad alcuni fenomeni di patologia vegetale. *Atti R. Accad. Lincei VI. Rend. Cl. Sci. Fis. Mat. e Nat.* **8**: 101-104. 1928.
11. CLUZET, J., and T. KOFMAN. Action des rayons ultraviolets, seuls ou associés aux rayons x, sur la germination. *Compt. Rend. Soc. Biol. [Paris]* **101**: 820-821. 1929.
12. COLMAN, J. Vita glass. *Gard. Chron.* **81**: 237. 1927.
13. COLLA S. Formazione della chlorofilla nella piante esposte alla luce di Wood. *Annales Botan.* **18**: 329-349. 1930.
14. DANE, H. R. The effect of ultra-violet radiation on soybeans. *Science* **66**: 80. 1927.
15. DANGEARD, P. A. La détermination des rayons actifs dans la synthèse chlorophyllienne. *Botaniste* **12**: XXII-XXVI. 1912.
16. DANGEARD, P. A. Recherches sur la pénétration des rayons violets et ultraviolets au travers des divers organes de la plante. *Bull. Soc. Bot. France* **61**: 99-103. 1914.
17. DANGEARD, P. A. Sur le pouvoir de pénétration des rayons violets et ultraviolets au travers des feuilles. *Compt. Rend. Acad. Sci. [Paris]* **158**: 369-370. 1914.
18. DE CANDOLLE, C. Étude de l'action des rayons ultraviolets sur la formation des fleurs. *Arch. Sci. Phys. et Nat. Genève* **28**: 265-277. 1892.
19. DEHÉRAIN, P. P. Expériences sur l'influence qu'exerce la lumière électrique sur le développement des végétaux. *Annales Agron.* **7**: 551-575. 1881.
20. DELF, M. E. The influence of ultra-violet light on plants. *Biol. Rev.* **3**: 261-269. 1928.
21. DELF, M. E., K. RITSON, and A. WESTBROOK. The effect on plants of radiations from a quartz mercury vapor lamp. *British Jour. Exp. Biol.* **5**: 138-154. 1927.
22. DETWILER, S. B. The effect of ultra-violet light on the germination of seeds and growth of seedlings of *Ribes rotundifolium* Mich. *Jour. Forestry* **29**: 131-133. 1931.
23. DHÉRÉ, C., and W. DEROGOWSKI. Sur l'absorption des rayons ultraviolets par les chlorophylles a et b et par la chlorophylle cristalline. *Compt. Rend. Acad. Sci. [Paris]* **155**: 653-656. 1912.

24. DIX, W. Vegetationsversuche mit ultraviolette Strahlen durchlässigem Glas. *Gartenbauwiss.* **2**: 365-368. 1929.
25. ELTINGE, E. T. The effect of ultra-violet radiation upon higher plants. *Ann. Missouri Bot. Gard.* **15**: 169-240. 1928.
26. ENGLISH, S. Loss of ultraviolet transparency in glasses. *Nature* **125**: 85. 1930.
27. FOY, N. R. The use of filtered ultraviolet light in the diagnosis of the various types of rye-grass in New Zealand. *New Zealand Jour. Agr.* **43**: 389-400. 1931.
28. FULLER, H. J. Stimulatory effects of ultraviolet radiation upon higher plants. *Science* **72**: 535-536. 1930.
29. FULLER, H. J. Stimulatory effects of radiation from a quartz mercury vapor arc upon higher plants. *Ann. Missouri Bot. Gard.* **18**: 17-40. 1931.
30. FULLER, H. J. Injurious effects of ultra-violet and infra-red radiations on plants. *Ann. Missouri Bot. Gard.* **19**: 79-86. 1932.
31. GENTNER, G. Über die Verwendbarkeit von ultravioletten Strahlen bei der Samenprüfung. *Prakt. Blätt. Pflanzenb. und Pflanzensch.* **28**: 166-172. 1928.
32. GOLA, G. Sulla riflessione di radiazioni ultraviolette per parte di alcuni organi vegetali. *Nuovo Giorn. Bot. Ital. n. s.* **34**: 143-156. 1927.
33. GRAHAM, R. H. D., and L. B. STEWART. Experiments with vita glass. *Trans. Bot. Soc. Edinburgh* **30**: 212-215. 1930.
34. GROSSMAN, M. 3-Jahre Kakteen im ultravioletten Licht. *Monatsch. Deutsch. Kakteen-Gesell.* **3**: 145-148. 1931.
35. H. Ultra-violet light and horticulture. *Gard. Chron.* **81**: 52. 1927.
36. HEROLD, H. Versuche mit ultraviolettdurchlässigem Glas. *Gartenw.* **33**: 229-230. 1929.
37. HERTEL, E. Über die physiologische Wirkung von Strahlen verschiedener Wellenlänge. *Zeitsch. Allgem. Physiol.* **5**: 95. 1905.
38. HERTEL, E. Über den Gehalt verschiedener Spektralbezirke an physiologisch wirksamer Energie. *Zeitsch. Physiol. und Diät. Therapie* **10**. 1906-1907.
39. HIGGINS, G. M., and C. SHEARD. Germination and growth of seeds as dependent upon selective irradiation. *Plant Physiol.* **2**: 325-335. 1927.
40. JACOBI, G. Untersuchungen über die Wirkung des ultravioletten Lichtes auf Keimung und Wachstum. *Beitr. Biol. Pflanz. (Cohn's)* **16**: 405-464. 1928.
41. KACHE, P., and others. Ultraviolette Strahlen als Hilfsmittel im Gartenbau. *Gartenzeitschr. Oesterr. Gartenb.-Ges. Wien.* 1928: 129-134.
42. KEW GARDENS. Experiments with vitaglass. *Gard. Chron.* **81**: 314. 1927.
43. KLUYVER, A. J. Beobachtungen über die Einwirkung von ultravioletten Strahlen auf höhere Pflanzen. *Sitzber. K. Akad. Wiss. Wien. (Math.-Naturwiss. Klasse) I.* **120**: 1137-1170. 1911.
44. KLUYVER, A. J. Beobachtungen über die Einwirkung von ultravioletten Strahlen auf höhere Pflanzen. *Anz. K. Akad. Wiss. Wien. (Math.-Naturwiss. Klasse)* **48**: 485-487. 1912.
45. KLUYVER, A. J. Ist man berechtigt, die mit dem ultravioletten Lichte der Heraeuslampe erzielten photochemischen Ergebnisse auf die bei der Pflanze im Sonnenlichte vor sich gehenden Prozesse ohne weiteres zu übertragen? *Oesterr. Bot. Zeitsch.* **63**: 49-51. 1913.
46. KÖHLER, A. Mikrophotographische Untersuchungen mit ultravioletten Licht. *Zeitsch. Wiss. Mikrosk.* **21**: 129-165, 273-304. 1904.
47. LAMPRECHT, H. Die Bedeutung der ultravioletten Sonnenstrahlen für die Entwicklung einiger Pflanzen. *Bot. Notar.* 1929: 311-340.

48. LEONARD, C. S. and J. M. ARTHUR. The reputed influence of ultra-violet light on the yield of *Digitalis* glucosides. *Journ. Amer. Pharm. Assoc.* **23**: 225-228. 1934.
49. MADDOCK, O. Vita glass. *Gard. Chron.* **84**: 434. 1928.
50. MALHOTRA, R. C. The influence of ultra violet rays, x-rays, and temperature on the germination of *Zea Mays*. *Jour. Indian Bot. Soc.* **11**: 1-27. 1932.
51. MAQUENNE, L., and E. DEMOUSSY. Influence des rayons ultra-violetes sur la végétation des plantes vertes. *Compt. Rend. Acad. Sci. [Paris]* **149**: 756-760. 1909.
52. MAQUENNE, L., and E. DEMOUSSY. Sur le noircissement des feuilles vertes. *Compt. Rend. Acad. Sci. [Paris]* **149**: 957-961. 1909.
53. MAQUENNE, L., and E. DEMOUSSY. Le noircissement post-mortal des feuilles. *Rev. Gén. Sci.* **21**: 196-203. 1910.
54. MARTIN, M. T., and M. A. WESTBROOK. The influence of ultraviolet radiation upon some plant cells. *Jour. Exp. Biol.* **7**: 293-307. 1930.
55. MASURE, M. P. The effect of ultraviolet radiation on growth and respiration of pea seeds, with notes on statistics. *Botan. Gaz.* **93**: 21-41. 1932.
56. McCREA, A. The effect of ultraviolet light upon *Digitalis purpurea*. *Science* **67**: 277-278. 1928.
57. McCREA, A. The effect upon *Digitalis purpurea* of radiation through solarized ultraviolet transmitting glass. *Science* **69**: 628-629. 1929.
58. McCREA, A. Prolonged effect on *Digitalis purpurea* of exposure under ultraviolet transmitting glass. *Science* **71**: 346. 1930.
59. McCREA, A. Some physiological effects of radiation on plant life. *Physical Therapeutics*. May, 1931.
60. METZNER, P. Über das optische Verhalten der Pflanzengewebe im langwelligen ultravioletten Licht. *Planta, Arch. Wiss. Bot.* **10**: 281-313. 1930.
61. MEZZADROLI, G., and E. VARETON. Azione dei raggi di Wood (circa 3600 Å.) sulla germinazione dei semi e sull accrescimento delle piante. *Rend. R. Accad. Lincei* **10**: 281-289. 1929.
62. MEZZADROLI, G., and E. VARETON. Azione dei raggi ultravioletti sulla germinazione dei semi e sull accrescimento delle piante. *Atti R. Accad. Naz. Lincei VI, Rend. I, Sci. Fis. Mat. e Nat.* **11**: 316-320. 1930.
63. OSMUN, A. V. Influence of light quality on plant growth. *Massachusetts Agric. Exp. Sta. Bull.* 260. 344. 1930.
64. OSMUN, A. V. Influence of light quality on plant growth. *Massachusetts Agric. Exp. Sta. Bull.* 271. 247. 1931.
65. PFEIFFER, N. Anatomical study of plants grown under glasses transmitting light of various ranges of wave length. *Botan. Gaz.* **85**: 427-436. 1928.
66. PILKINGTON, G. L. Effect of vita glass on plants. *Gard. Illus.* **52**: 246. 1930.
67. PIRES DE LIMA, A. Action des rayons ultra-violetes, de quelques colorants et de quelques alcaloïdes sur la germination du seigle. *Compt. Rend. Soc. Biol. [Paris]* **105**: 493-495. 1930.
68. POPOFF, M. Die Zellstimulation. Ihre Anwendung in der Pflanzenzüchtung und Medizin. (cf. pp. 307-310.) Paul Parey; Berlin, 1931.
69. POPP, H. W. The effect of ultra-violet light on the germination and early growth of plants. Thesis in College Library of the Pennsylvania State College, State College, Penn. 1922.
70. POPP, H. W. (In Ellis, C. and Wells, A. A.) The chemical action of ultraviolet rays. (Cf. p. 247.) New York, 1925.
71. POPP, H. W. A physiological study of the effect of light of various ranges of wave lengths on the growth of plants. *Amer. Jour. Bot.* **13**: 706-736. 1926.
72. POPP, H. W., and F. BROWN. Effects of ultra-violet rays upon radish seeds and seedlings. *Proc. Penn. Acad. Sci.* **2**: 99. 1927-1928.

73. POPP, H. W., and F. BROWN. Is ultraviolet radiation stimulating to plants? *Amer. Jour. Bot.* **15**: 623. 1928.
74. POPP, H. W., and F. BROWN. A review of recent work on the effect of ultraviolet radiation upon seed plants. *Bull. Torrey Botan. Club.* **60**: 161-210. 1933.
75. RAYBAUD, L. Influence des radiations ultra-violettes sur la germination des graines. *Compt. Rend. Soc. Biol. [Paris]* **68**: 772-774. 1910.
76. RAYBAUD, L. Influence des radiations ultraviolettes sur la plantule. *Rev. Gén. Bot.* **25**: 38-45. 1913.
77. REINHOLD, J. Frühsalatkultur unter Ultraviolettglassorten. *Obst. und Gemüseb.* **75**: 106-107. 1929.
78. REINHOLD, J., and M. SCHMIDT. Versuche mit verschiedenen Glassorten im Frühgemüsebau. *Gartenbauwiss.* **3**: 301-330. 1930.
79. REINHOLD, J., and F. SCHULZ. Untersuchung über den Einfluss von Ultraviolettglassorten auf den Pflanzenertrag im Gartenbau. *Gartenbauwiss.* **2**: 40-78. 1929.
80. ROEDER, W. VON. Die Verglasung mit Uviolglas. *Monatsch. Deut. Kakteen-Gesell.* **2**: 35-37. 1930.
81. ROSENHEIM, O. Biochemical changes due to environment. *Biochem. Jour.* **12**: 283-289. 1918.
82. ROWLEE, W. W. The effect of electric light upon tissues of leaves. *Proc. Soc. Prom. Agric. Sci.* (1898): 50-58.
83. RUSSELL, N. K. Vita glass. *Gard. Chron.* **81**: 218. 1927.
84. RUSSELL, E., and W. K. RUSSELL. Ultraviolet radiation and actinotherapy. 2nd Ed., 429 pp. Edinburgh, 1927.
85. SACHS, J. VON. Über die Wirkung der ultravioletten Strahlen auf die Blütenbildung. *Arb. Botan. Inst. Würzburg* **3**: 3. 1887.
86. SALEEBY, C. W. Growth of plants under vitaglass. *Gard. Chron.* **81**: 452. 1927.
87. SAYRE, J. D. The development of chlorophyll in seedlings in different ranges of wave lengths of light. *Plant Physiol.* **3**: 71-77. 1928.
88. SCHANZ, F. Einfluss des Lichtes auf die Gestaltung der Vegetation. *Ber. Deut. Botan. Ges.* **36**: 619-632. 1918.
89. SCHANZ, F. Wirkungen des Lichtes verschiedener Wellenlänge auf die Pflanzen. *Ber. Deut. Botan. Ges.* **37**: 430-442. 1919.
90. SCHROETER, C. Das Pflanzenleben der Alpen. Pp. 627-631. Zürich, 1908.
91. SCHULZE, J. Über die Einwirkung der Lichtstrahlen von 280 m μ Wellenlänge auf Pflanzenzellen. *Beih. Botan. Centrabl.* **25**: 30-80. 1910.
92. SECRETT, F. A. Vita glass. *Gard. Chron.* **87**: 313. 1930.
93. SENN, G. Einfluss von Licht und Temperatur in den Alpen auf Physiologie und Anatomie der Pflanzen. *Verh. Klimatol. Tagung in Davos.* P. 11. 1925.
94. SHAW, C. H. The possible rôle of light in relation to alpine plants. *Science.* **27**: 339. 1908.
95. SHEARD, C., and G. M. HIGGINS. The influence of selective and general irradiation by a quartz mercury arc lamp upon the germination and growth of seeds. *Science.* **65**: 282-284. 1927.
96. SHEARD, C., and G. M. HIGGINS. The influence of direct irradiation by a quartz-mercury arc lamp upon the germination and growth of certain seeds. *Plant Physiol.* **2**: 461-473. 1927.
97. SHEARD, C., G. M. HIGGINS, and W. I. FOSTER. Germination of seeds, growth of plants, and development of chlorophyll as influenced by selective solar irradiation. *Science.* **71**: 291-293. 1930.

98. SHIBATA, K., M. KISHIDA, and I. NAGAI. Studies on the presence and physiological significance of flavone derivatives in plants. I. *Botan. Mag. [Tokio]* **29**: 118-132. 1915.
99. SHIBATA, K., M. KISHIDA, and I. NAGAI. II. The chemical biology of alpine plants. *Botan. Mag. [Tokio]* **29**: 301-308. 1915.
100. SHIBATA, K., M. KISHIDA, and I. NAGAI. III. The flavone content of tropical plants. *Botan. Mag. [Tokio]* **30**: 149-178. 1916.
101. SHIBATA, K., M. KISHIDA, and I. NAGAI. The occurrence and physiological significance of flavone derivatives in plants. *Jour. Biol. Chem.* **28**: 93-108. 1916.
102. SHIRLEY, H. L. The influence of light intensity and light quality upon the growth of plants. *Amer. Jour. Bot.* **16**: 354-390. 1929.
103. SHULL, C. A., and H. B. LEMON. Penetration of seed coats by ultraviolet radiation. *Botan. Gaz.* **92**: 420-429. 1931.
104. SIBILIA, C. Azione dei raggi ultravioletti su piantine di lupino. *Bull. Soc. Bot. Ital.* 1925: 160-164.
105. SIEMENS, C. W. On the influence of electric light upon vegetation and on certain physical principles involved. *Nature* **21**: 456. 1880. (*See also Proc. Roy. Soc. London* **30**: 210-230. 1880.)
106. SIMON. Die Ernährung unserer Kulturpflanzen. *Zeitsch. Ernährung* **2**: 82-83. 1932.
107. STEWART, W. D., and J. M. ARTHUR. Some effects of radiation from a quartz mercury vapor lamp upon the mineral composition of plants. *Contr. Boyce Thomp. Inst.* **6**: 225-245. 1934.
108. STOKLASA, J. Über den Einfluss der ultravioletten Strahlen auf die Vegetation. *Centralbl. Bakt.* II. Abt. **31**: 477-495. 1911.
109. STOKLASA, J. Über die Einwirkung der ultravioletten Strahlen auf die chlorophyllhaltige Zelle. *Zeitsch. Pflanzenkrank.* **24**: 193-204. 1914.
110. STOKLASA, J. (and others). Ueber die Wirkung der ultravioletten Strahlen auf die Vegetation. *Biol. Listy Bohemia* p. 81. et seq. 1912.
111. THOMSON, R. Tomatoes under vitaglass. *Agric. Gaz. New South Wales* **39**: 596. 1928.
112. TINCKER, M. A. H. Some experiments with ultra-violet ray glasses. *Jour. Roy. Hort. Soc.* **56**: 79-87. 1930.
113. TINCKER, M. A. H. Experiments with ultra-violet ray glasses—II. *Jour. Roy. Hort. Soc.* **57**: 51-57. 1932.
114. TOTTINGHAM, W. E. Are leaf lipides responsive to solar radiation? *Science.* **75**: 223-224. 1932.
115. TOTTINGHAM, W. E., and J. G. MOORE. Horticultural investigations at Wisconsin. *Wisconsin Agric. Exp. Sta. Bull.* 410. 38. 1930.
116. TOTTINGHAM, W. E., and J. G. MOORE. Some phases of plant development under vita glass. *Jour. Agric. Res.* **43**: 133-163. 1931.
117. TSUJI. Ultraviolet rays and the sugar cane, pineapple, and banana industries. *Louisiana Planter* **60**: 413-414. 1918.
118. URSPRUNG, A. and G. BLUM. Über die Schädigkeit ultravioletter Strahlen. *Ber. Deut. Botan. Ges.* **35**: 385-402. 1917.
119. VALENTIN, H. Über physiologische und chemische Versuche mit U- V-Strahlendurchlässigen Gläsern sowie eine Methode zur Wertbestimmung derselben. *Pharm. Zeitg.* **75**: 982-984, 995-998, 1005-1008. 1930.
120. VODRÁŽKA, O. Výzkumy dřeva v ultrafialovém světle. Cast II. (Holzuntersuchungen im Ultravioletlicht. II. Teil.). *Věstník Ceskosl. Akad. Zeméd.* **5**: 586-590. 1929. (German summary pp. 588-590.)
121. WESTFIELD COLLEGE. Vitaglass tests. *Gard. Chron.* **83**: 462. 1928.

122. WITHROW, R. B. Cellophane and gelatine filters for the ultra-violet. Bull. Basic Sci. Res. [Cincinnati] **3**: 82-89. 1931.
123. WITHROW, R. B., and H. M. BENEDICT. Preliminary investigation of the growth promoting effect of selected ultra-violet radiations on plants. Bull. Basic Sci. Res. [Cincinnati] **3**: 161-175. 1931.
124. WOOD, A. R., and M. N. LEATHWOOD. Glasses transparent to ultra-violet radiation. Nature **124**: 441-442. 1929.
125. WOOD, A. R., and M. N. LEATHWOOD. Glasses transparent to ultraviolet radiation. Nature **125**: 351. 1930.
126. WYND, F. L., and H. J. FULLER. Some effects of ultra-violet radiation upon the calcium and phosphorus content of higher plants. Ann. Missouri Bot Gard. **18**: 565-572. 1931.

Manuscript received by the editor November, 1934.



XXVII

THE EFFECTS OF RADIATION ON FUNGI

ELIZABETH C. SMITH

Department of Botany, University of Wisconsin

Introduction. Visible and ultra-violet radiation: Mycelium—Fruiting structures—Spores—Mutations and saltations—Physiological properties. X-rays. Rays emitted from radioactive substances. General summary. References.

INTRODUCTION

Interest in the effects of light on fungi has now lasted well over a century. The early work was of a decidedly qualitative nature and dealt only with light of the visible spectrum. Since that time investigations have been extended to include radiations from the short gamma waves to Hertz waves of a hundred meters. Unfortunately even the most recent work is largely of a qualitative nature. For the most part, when monochromatic light was used, the intensity was not measured, and when the intensity was measured, the quality of the light used was not accurately determined; or the intensity was not kept constant when the wave-length was changed. Throughout most of the work there has been an inadequate control of environmental conditions. These uncontrolled factors have often led to an unfair interpretation of results, and this fact must be given due weight in any attempt to estimate what is known about the effects of radiation on fungi. In view of the absence of any attempt, apparently, to bring together the scattered and extensive literature in this field, and further, in view of the wealth of biological material that has been considered, it has seemed desirable to include in this paper observations that vary greatly in merit or importance.

VISIBLE AND ULTRA-VIOLET RADIATION

MYCELIUM

Pigmentation.—Since early times botanists have observed that fungi which are growing in the dark are likely to be very pale in color in comparison with those grown in the light. Bonorden (12) made note of this as early as 1851, and since that time Smith and Swingle (170), Bessey (6), Robinson (159), Milburn (122), Kosaroff (93), Morris and Nutting (127), and others have made similar observations. Humboldt and Seyne (cf. Elfving, 39), however, showed that this was not applicable to all fungi since they found colored varieties growing in complete darkness. Lieske (105) also found that the formation of pigment in Actinomycetes is apparently independent of the action of light. There

has been little study of the effects of different light intensities on pigmentation. Smith and Swingle (170) reported that within the limits used in their experiments color appears sooner in the mycelium of *Fusarium oxysporum* with the highest light intensities. They also found that after the light-color response any new growth of the mycelium in darkness is white, indicating that the effects produced by light cease almost as soon as the light is removed. Experiments made by Smith and Swingle (170), Bessey (6), Robinson (159), and McCrea (119) all show that pigment production is induced by the blue end of the spectrum, and McCrea's results show in addition that red rays exert no inhibiting effect. In all these experiments liquid light filters were used. The culture medium may also influence the degree of pigment production or may even determine whether pigment is formed. Such results have been reported by Smith and Swingle (170) and by Morris and Nutting (127).

Growth Rate.—Sunlight has long been known to exert an inhibitive effect on the growth rates of fungi. Qualitative studies have been made by Fries (52), Carnoy (20), Brefeld (15, 16), Downes and Blunt (35), Pfeffer (145), Stameroff (172), Zopf (cf. Elfving, 39), Regel (155), Vines (189), Ternetz (187), Schulze (167), Lieske (105), and Potts (148). Small amounts of sunlight retard whereas large amounts kill fungi. Qualitative studies have also been made of the retarding effects of ultra-violet radiation. Among these might be mentioned those of Lieske (105), Porter and Bockstahler (147), Dillon-Weston and Halnan (34), Welch (192), and Feuer and Tanner (51).

Attempts were next made to show which regions of the spectrum exert harmful action. Regel (155), Vines (189), and later Buchta (18), all using liquid filters, found that it is the blue end of the visible spectrum that retards growth. It was also found by Lieske (105), Buchta (18), and others that the ultra-violet is more harmful than the blue. In studying different regions of the ultra-violet Johnson (83), Hutchinson and Newton (80), and Hutchinson and Ashton (79) reported that the shortest wave-lengths appear to be the most harmful. Johnson used glass filters, and Hutchinson and Newton, and Hutchinson and Ashton used a monochromator, but the intensities were not measured for the different wave-lengths studied so that a final evaluation of the results is provisional. More recently, however, two papers have appeared, one by Ehrismann and Noethling (37) and the other by Oster (141), in which careful studies have been made of the effects of equal intensities of different wave-lengths in the ultra-violet on the growth of yeast cells. In both studies monochromatic light was used and the intensities were measured with a photoelectric cell or thermopile. Ehrismann and Noethling considered the energies necessary to produce 1 to 10 per cent killing, whereas Oster considered 50 per cent killing. However, when

wave-lengths are plotted against the energies necessary to kill, the curves are essentially similar with minima at about 2650 Å. Ehrismann and Noethling worked only with wave-lengths above 2400 Å. Oster worked with wave-lengths as low as 2200 Å, and his curves indicate another minimum below 2300 Å. It is interesting to note that these curves are comparable in shape with curves which have been obtained for bacterial cells. A comparison made by Oster of the energies necessary to kill 50 per cent of the cells irradiated shows, however, that 457 erg mm.² are necessary at 2652 Å compared with 23,500 ergs mm.² at 3022 Å, or roughly five times the energy range which has been obtained for *Staphylococcus aureus*. The curves are also similar to those of certain nucleoprotein derivatives known to occur in yeast cells. Oster pointed out that this suggests that possibly the effects of ultra-violet radiation may result from the absorption of energy by these nucleoproteins.

A number of recent papers have laid much emphasis on the different degrees of injury which may be produced by ultra-violet radiation. This is not a new idea. Schulze (167) as early as 1909 reported that when *Mucor stolonifer* is irradiated with diffuse light of 2900 Å, there is—except with strong intensities—an interval or latent period before growth is hindered. If the hyphae are irradiated until growth stops, there is no further growth, but if the irradiation is not continued so long, growth often stops sometime after irradiation but is resumed again after a period of no growth. Lacassagne (96) divided yeast cells which had been exposed to ultra-violet radiation into three classes; (a) cells which after a retardation in cell division ultimately recover their reproductive powers; (b) cells which divide only once and then die; (c) cells which die without dividing. Wyckoff and Luyet (196) and Oster (139) have also placed yeast cells in these different categories, but Oster considers an additional class which falls between (a) and (b) in which the metabolic functions of the cell are retarded as shown by a lowered rate of oxygen consumption.

In the early studies of the retarding effects of radiation on growth rates no absolute measurements were made of the intensities of light used. However, comparisons were made of the different exposures to the same intensities necessary to produce the same effect in different fungi and to produce different effects in the same fungus. Von Recklinghausen (190) found that it took more than six times as long to kill yeasts as to kill bacteria in water, and Houghton and Davis (78) made observations on the marked resistance to ultra-violet of molds as compared with bacteria. Dillon-Weston and Halnan (34) showed that increasing the intensity increases inhibitive and lethal effects. More recently absolute measurements of intensity with a thermopile or photoelectric cell have been made by Wyckoff and Luyet (196), Ehrismann and Noethling (37), Schreiber (166), and Oster (139). The

data obtained by Wyckoff and Luyet, Schreiber, and Oster can all be recorded in the form of typical S-shaped survival curves when the percentage of survivors is plotted against the energy of light used. All these data were recorded for yeasts. Various interpretations may be given to these curves. Some consider the logarithmic portion as denoting a monomolecular reaction. Other environmental factors are considered as responsible for producing deviations from the logarithmic type. Others attribute the shape of the curve to multiple-quantum hits on a sensitive region in the cell, while still others consider the curve as merely a normal probability curve due to differences in resistance of individual cells. At the present time the multiple-quantum-hit theory seems to be in favor, although no entity in the cell which might be considered as the sensitive region has been demonstrated. By a mathematical procedure developed by Mme. Curie it is possible to determine the number of quantum hits necessary to kill when the amount of energy and the survival ratio are known. A single hit is defined as the absorption of one quantum in the sensitive region. Holweck and Lacassagne (77) determined that nine hits are necessary to kill yeast cells with mixed ultra-violet radiation of wave-lengths of 2800 to 3800 Å. Schreiber (166) reported that six hits are necessary at 2540 Å and 29 at 2290 Å. Oster and Arnold (142), however, found that the number of hits necessary to kill is about the same for different wave-lengths in the ultra-violet but that the number of quanta involved in the production of different degrees of inhibition of cell division vary from approximately four to six, and further that the number of quantum hits increases with an increase in the degree of inhibition secured. Holweck (76) has gone so far as to calculate that the size of the sensitive zone approximates that of the yeast nucleus. Oster and Arnold (142) expressed the opinion that different quantum hits which they obtained may indicate the existence within the yeast cell of several entities each of which is involved in a future budding. Wyckoff, who has used the multiple hit theory as an explanation of lethal action in fungi, has recently adopted a somewhat modified point of view in his statement that "it is very likely that the quantum picture has a certain reality for electron killing, but it is equally probable that the same order of death from ultra-violet light is an expression of variable susceptibilities" (195).

The Bunsen-Roscoe law holds within narrow intensity limits for yeasts. Oster (140) found that the law is valid for variations in intensity of the incident radiation only up to 30 per cent. Schreiber (166) also found that the law holds within narrow limits, but below these limits a long exposure with a low light intensity is much more effective than a short exposure with a higher intensity. Fulton and Coblenz (54) noted that the Bunsen-Roscoe law also holds for intermittent ultra-

violet radiation on *Penicillium digitatum* within the limits of the intensities that they used.

It has already been mentioned that deviations from the logarithmic type in the S-shaped survival curves have been attributed by many to other varying factors. The factors which have been considered as possibly responsible have been age of the cultures used and the temperature at which the cells are irradiated. The results of Oster (140) and Schreiber (166) are in opposition with regard to the effect of age on the sensitivity of yeast cultures to ultra-violet. Oster found that 20 to 50 per cent more incident energy is necessary to produce a given effect in a 15-day than in a 24-hr. culture, whereas Schreiber found that the age of the culture makes little difference in the sensitivity of the yeast cells. The effect of the temperature at which the cells are irradiated was also investigated by Schreiber and by Oster. Oster, working with four different temperatures ranging from 8° to 29.5°C., obtained 1.10 as an average value for the temperature coefficient of lethal action. This value agrees very closely with those obtained for bactericidal action. It suggests a physical rather than a chemical process. Oster noted that the values increase slightly as the temperature is increased. Since 30°C. is a critical temperature for the strain of yeast which he used, he attributed the increase to the possible influence of another reaction. Schreiber studied the combined effects of radiation and temperature. He found that the effects are very complex. He did not calculate temperature coefficients, but he made numerous curves which indicate the complexity of the reactions.

One factor which may markedly affect lethal action and which has been given very little attention is the shielding action of the medium. Any growth below the surface does not receive the full effect of the rays. This has been discussed in some detail by Dillon-Weston and Halnan (34). The composition of the medium and its state of ionization may also alter the effects produced by irradiation. Many investigators have noted that there is no difference in fungi planted on an unirradiated and an irradiated medium. However, they have not considered the more complicated relation of the effects of radiation on the fungus and on the medium in which it is growing at the time of irradiation. Teichler (186) varied the amounts of sodium chloride and calcium chloride in the medium and noted the differences in the number of cells which appeared after irradiation. Hinrichs (73) reported that ultra-violet radiation causes substances to be formed in the ordinary nutrient solution which are toxic to yeast. Smith (169) also noted the effects of the composition of the medium on stimulation in *Fusarium*.

The phenomenon of stimulation has been in dispute for some time. It has been considered by many as an irregular sort of process whose occurrence is unpredictable. A number of workers have reported stimu-

lation of the growth rates of fungi with ultra-violet radiation. Nadson and Philippov (134) observed in a yeast colony that there is much greater growth around the edges of an irradiated zone than outside the zone whereas growth in the middle is retarded. The stimulation has been attributed to small amounts of scattered radiation. However, when small doses of radiation have been used in an attempt to obtain stimulation, the results have been on the whole quite unsuccessful. Wyckoff and Luyet (196), Schreiber (166), and Smith (169) obtained no evidence of stimulation with small doses of ultra-violet. Schreiber made very extensive experiments with a large number of different wave-lengths and intensities. Chavarria and Clark (24), however, found that short exposures to ultra-violet always produce a stimulation in the growth rates of *Montoyella* cultures, whereas longer exposures are lethal. The difference in the results obtained by Chavarria and Clark from those of other workers may be due to the difference in the times at which measurements of the amount of growth were made after irradiation. That this might be a real factor is brought out by the experiments of Smith (169) who found in *Fusarium* cultures only temporary stimulation, which was never obtained without a previous retardation. After a short period of time the growth rate returned to normal. Smith considered stimulation of vegetative growth as merely an indirect effect of radiation and a direct effect of retardation, since other agents which produce a retardation also produce stimulation. Smith also found that temperature conditions and nutritional conditions which favor the growth of the fungus favor also stimulation. The idea was suggested that those conditions which favor the formation and accumulation of labile products favor also stimulation following retardation. This is not in agreement with the work of Hutchinson and Newton (80) who obtained the greatest stimulation in slow growing cultures of yeast. Hutchinson and Newton also studied the effects of individual wave-lengths from a monochromator on the growth rate of yeast. With some wave-lengths they obtained stimulation and with others retardation. However, differences in the effects produced by different spectral lines may be caused entirely or partially by differences in intensity. This factor was not considered in the investigation and a final evaluation of the results is provisional.

The effects of radiation on the growth rates of fungi are of some practical as well as theoretical importance. Its effects on yeast are of importance to the brewing industry and radiation may also assume some importance to the plant pathologist in the control of certain plant diseases. Hey and Carter (71), for example, found that it is possible to give wheat seedlings an amount of ultra-violet which gives a fairly effective control of *Erysiphe graminis* without causing damage to the host. The effects of radiation on fermentation will be discussed more fully in the discussion of physiological properties.

Morphology.—Certain morphological changes may be readily produced in fungi exposed to radiation. By a microscopic examination very pronounced differences in the shape and appearance of fungus colonies were observed by Berde (5) and Schreiber (166). Schulze (167) made some very interesting microscopic observations of the mycelium of *Mucor stolonifer* which was irradiated with sublethal doses of ultraviolet radiation of 2900 Å. About 30 min. after irradiation the hyphae become densely granular, increase to almost double their usual diameter, and the tips of the hyphae become bulbous or club-shaped. If not irradiated too long, there appears after an interval, depending on the time of irradiation and the intensity, a clear mass of protoplasm in the swollen end of each hypha from which arises a new hypha. The reproductive processes of cells are apparently hindered with much lower light intensities than the growth processes. Doses which are too small to prevent growth may be sufficient to stop division. This results in the production of giant cells and has been observed by many workers including Elfving (38), Reinhard (157), Lacassagne (96), and Holweck (76).

FRUITING STRUCTURES

Form.—Many of the early botanists observed that fungi which are growing in dark places have quite a different shape from those in the light. One of the earliest records of this change in form due to light was reported by Fries (52) as early as 1821. He observed that in the dark the stalks of mushrooms are longer and often branched, and unstalked forms become stalked. Since observations were made in the field, it is not clear to what extent other factors may have been involved. Other observers including Brefeld (15), Vines (189), Holtermann (cf. Ternetz, 187), and Buller (19) found that a number of the Mucorales and Basidiomycetes develop elongated fruiting structures in the dark. Fries (52) also observed that certain Myxomycetes, Hyphomycetes, Basidiomycetes, Pyrenomycetes and truffles are not affected in their development by a lack of light. These last observations have been confirmed by later writers and have been found to apply rather generally to a large number of families and genera.

Zonation.—A number of investigators have studied the effects of light on the arrangement of conidiophores or fruiting bodies in concentric rings. The phenomenon is apparently quite complex involving the interaction of a number of different environmental factors. The results which have been reported are somewhat contradictory, owing probably to insufficient control of environmental conditions and to the fact that different species may react very differently to the same conditions. As yet sufficient data from controlled experiments are not available to draw definite conclusions. A number of workers including Hedgcock (69),

Gallemaerts (56), Hutchinson (81), Molz (124), Stevens and Hall (179), Hall (65), Rahn (153), and Bisby (8) found that an alternation of light and dark is necessary for zonation. Others, however, such as Reide-meister (156) and Munk (129), found that zones are formed only in continuous darkness. Hedgcock (69) and Gallemaerts (56) determined the wave-lengths of light which are effective in producing zonation, but their results are contradictory, even though they used the same species of fungi. Light is not the only factor which may cause zonation. Bisby (8), Hall (65), and Ellis (40) showed that an alternation of temperature will produce zonation while Milburn (122), Hedgcock (69), Moreau (125), and Ellis (40) showed that the quality of the medium may determine whether or not zonation occurs. One of the most interesting discussions of zonation in fungi was written by Brown (17). He noted that zonation in some strains of *Fusarium* is dependent on light while in other strains there appears to be no correlation. He gave the following conditions as necessary for zonation in response to light changes: (a) the fungus should be affected in its sporing capacity by light; (b) a nonstaling type of mycelial growth should be maintained from day to day; and (c) the medium should not be such as to permit such intense sporulation that successive zones fuse. His work is valuable chiefly because of his appreciation of the complex of factors involved. The influence of light on zonation in fungi may differ with the species concerned, but it is highly important that the influence of all factors should be evaluated and that any indirect effects of light should be distinguished from direct effects.

Initiation of Fruiting and Further Development.—Fungi may be classified in the following distinct groups with regard to their ability to fruit under different light conditions: (a) those in which fruiting is independent of light; (b) those which will fruit only in the light; (c) those in which light is necessary only to produce the fundamentals of fruiting structures; and (d) those in which light is not necessary to produce fundamentals but is necessary for the further development of fruiting structures. A familiar example of the first group is *Agaricus campestris* which is cultivated by mushroom growers on a large scale in caves and cellars in darkness which is complete except when the cellars are visited by attendants with candles or torch lamps. It is grown in this way because of the better yield assured by the more uniform temperature maintained in the absence of light. Other fungi belonging to this group were described by Harter (66), Lendner (102), and Buller (19). *Plenodomus* and certain agarics described by Coons (25) and Lendner (102), respectively, belong to group (b). Brefeld (15, 16), Holterman (cf. Ternetz, 187), Ternetz (187), Harter (67), and Schenck (164) cited a number of different species which belong to group (c). Some of the most common among these are certain *Coprinus* species, *Tomentella*, *Diaporthe*,

Ascophenes, and *Bolbitius*. *Pilobolus microsporus* as described by Brefeld (15, 16) belongs to group (d).

The wave-lengths which are most effective in causing fruiting in those species for which light is essential were studied by Brefeld (16), Klein (90), Elfving (39), Lendner (102), and Luyet (111). These experiments vary widely in accuracy and there are no general conclusions which can be drawn. Regel (155), Brefeld (16), and Lakon (98), however, all found that the blue region of the spectrum is most effective for the development of fundaments of fruiting structures. They used liquid filters and Lakon also used glass filters. Regel studied *Pilobolus*, Lakon *Coprinus*, and Brefeld observed both forms.

The exposures necessary to induce the formation of fruiting bodies (in fungi from group c) are apparently very short according to Brefeld (15), Lehman (101), and Schenck (164). Robinson (159) and Schenck (164) have both studied in some detail the effects of light intensity on the production of fruiting bodies. They found that the duration as well as the intensity is important. Robinson reported that within the limits employed the time necessary for the production of oögonia and antheridia in *Pyronema confluens* is proportional to the intensity. He also noted that light energy can be utilized in the production of reproductive structures only if a check to vegetative growth has previously occurred. This check leads to the initiation of potentially reproductive branch systems. If light falls on the culture shortly before the actual check, it appears to be available for subsequent utilization, whereas if it is received later than the growth check, more energy appears to be necessary to produce the same results.

In certain cases cultures may react differently to light depending on the medium on which they are growing. As an example of this Lendner (102) cited *Mucor flavidus* which forms sporangia in the dark only if it is growing on a solid medium.

Growth Rates.—Light may determine not only whether fruiting bodies are formed but also the rate at which they develop. The sporangiophores of *Phycomyces nitens* are exceedingly sensitive to changes in light intensity. Bullot (cf. Klebs, 88) showed that the sporangiophores grow faster in continuous light than in the dark. Later Blaauw (9) studied the effects of varying light intensities. He observed that the sporangiophores respond to an increase in intensity by a temporary increase in the growth rate. This is followed by a decrease and brief fluctuations until the original rate is regained. With one-sided illumination Oehlkers (138) reported that only the first maximum appears. In either case to produce a new stimulation of growth it was found that the intensity must be again increased by a definite amount. Blaauw (9) found that the sporangiophores become increasingly sensitive to stimulation by light the longer they are kept in the dark. Tollenaar and Blaauw (cf. Castle,

21) estimated the amount of light necessary to produce a just perceptible increase in the growth rate. They found that the increase in sensitivity is a simple logarithmic function of the time that the fungi are kept in the dark, but Wiechulla (194) found that this holds only for certain energy values. He determined that the amount of light necessary to produce a change in the growth rate is between $\frac{1}{2}$ and $\frac{1}{4}$ mcs. A certain amount of time elapses between the first reception of light and stimulation of the growth rate. Castle (21) found that this reaction time is compound, consisting of an exposure period and a latent period. In the latent period he included both the period in which photochemical action occurs and any "action time" necessary for the response. During the latent period light is not necessary. The duration of the latent period is constant for a particular intensity unless the duration of exposure is reduced below a certain minimum. Below this minimum the reaction time lengthens progressively as the time of exposure decreases. Castle (22) also found that there may be a "dark-growth" response as well as a "light-growth" response. Sporangioophores adapted to light respond to a sudden darkening by a temporary decrease in the rate of elongation after a latent period of several minutes. The reaction time of the "dark-growth" response is compound like that of the "light-growth" response. The rate of dark adaptation was found to be proportional to the logarithm of the preceding light intensity and the amount of dark adaptation which takes place before the response occurs is always constant.

SPORES

Production.—A small amount of evidence has accumulated to indicate that light may affect spore characteristics. It was noted by von Muggenburg (128) that hyphae appearing on the cut half of an apple have crescent-shaped conidia in the dark and club-shaped ones in the light. Appel and Wollenweber (cf. Morris and Nutting, 127) also found that when *Fusarium* cultures are grown in the dark the conidia are variously shaped and unevenly septate. There are also reports of spores produced by irradiation which would not normally occur. Ramsey and Bailey (154) reported that conidia were produced in a strain of *Fusarium coeruleum* when the cultures were exposed to ultra-violet radiation transmitted from a quartz-mercury-vapor arc and filtered through vita glass. This strain had never previously produced conidia. They also found that cultures of *Fusarium argilaceum* may produce only chlamydo spores after irradiation. Stevens (173, 174, 176, 178) exposed a large number of fungus species to the full radiation of a quartz-mercury-vapor lamp. He found, however, that ultra-violet may initiate the development of reproductive structures in great numbers where they would not occur without irradiation, but in no case was he able to initiate structures

which are not known to be occasionally produced by these fungi in the natural course of events. Perithecia were produced in cultures of *Glomerella cingulata* (173, 174), *Colletotrichum lagenarium* (178), and a species of *Coniothyrium* (173). Pycnidia were formed in *Coniothyrium* (176). These changes were all brought about by exposures of less than 1 min. at a distance of 20 cm. from the lamp. None of the changes was hereditary. However, in only a few of the many species which he irradiated was he able to produce any change in the method of reproduction.

As early as 1852, Tulasne (cf. MacDougal, 112) observed that the sporophores of some fungi produce spores only in the light. Other species than those observed by Tulasne were found by Brefeld (16), Lendner (102), and Gräntz (59) to require light for spore production. *Coprinus*, *Sphaerobolus*, and *Pilobolus* are some of the fungi which fall in this group. Loew (106) found, however, that spore production in *Penicillium*, *Trichothecium*, and *Mucor stolonifer* is independent of light. For those fungi which do require light to produce spores Brefeld (16) found that only a few hours' exposure is sufficient to induce complete development in the dark. The studies which have been made to determine which wave-lengths are necessary for spore production are contradictory, probably owing to the variety of environmental conditions and species employed. Such studies were made by Klein (90), Costantin (cf. Moreau and Moreau, 126), Reidemeister (156), Moreau and Moreau (126), Rabinovitz-Sereni (152), and Purvis and Warwick (150). No general conclusions can be drawn from this work.

Long exposures to ultra-violet radiation decrease spore production, whereas short exposures stimulate. The inhibitive effects of relatively long exposures were noted by Purvis and Warwick (150), Porter and Bockstahler (147), Hutchinson and Ashton (79), Stevens (176), and Smith (169). One of the earliest reports of stimulation of spore production with small amounts of radiation was made by Purvis and Warwick (150). They exposed portions of a *Mucor* culture for 10 to 20 min. to the direct radiation of a Bach quartz-mercury-vapor lamp placed at 30 cm. from the culture. The temperature of the culture was never higher than 30°C. The portion of the culture below the center of the aperture was killed, but at the edges of the irradiated region spores were produced in great abundance. Since that time a number of investigators including Stevens (176), Dillon-Weston (33), Hutchinson and Ashton (79), Ramsey and Bailey (154), Bailey (2), and Smith (169) have tried short exposures to ultra-violet radiation and obtained marked stimulation to spore production in a wide variety of species. Smith made spore counts and gave curves showing quantitatively the effects of different short exposures. Both Ramsey and Bailey, and Smith reported that increased spore production does not seem to be directly correlated with inhibition in the growth rate. According to Bailey and to Ramsay and Bailey increasing

the number of exposures is more effective than increasing the length of exposure.

There have been several investigations to determine which wave-lengths are most effective in stimulating spore production. Both Stevens (173) and Bailey (2) found that only wave-lengths in the ultra-violet are effective. Ramsey and Bailey (154) obtained the greatest stimulation of spore production in *Macrosporium Tomato* and *Fusarium Cepae* with wave-lengths between 2535 and 2800 Å and exposures of 15 to 30 min. at 60 cm. from a mercury arc. There is slight stimulation with wave-lengths between 3120 and 3334 Å. With wave-lengths of less than 2535 Å there is a stimulation of spore production, but there are also some lethal effects and an inhibition of mycelial development. All this work was done with filters. Bailey (2) irradiated 59 varieties of *Fusarium* with a Cooper-Hewitt quartz-mercury arc. Most species tested give maximum spore production under vita glass which transmits to 2650 Å. Bailey as well as Ramsey and Bailey reported a stimulation of spore production with old cultures.

Certain environmental factors may affect the amount of stimulation of spore production produced by radiation. Stevens (175), for example, found that in *Glomerella cingulata* those sugars which greatly favor growth also increase perithecial production on irradiation. Smith (169) found that the temperature at which *Fusarium* cultures are irradiated markedly affects the number of spores produced. Temperature alone may affect the number of spores produced, but the effects of temperature and radiation are not additive since the amount of stimulation over the controls with ultra-violet is different in cultures grown at different temperatures. This is in contradiction to the work of Ramsay and Bailey (154) who reported that temperature is not an important factor in determining sporulation in *Macrosporium Tomato* and *Fusarium Cepae*. However, they considered the effects of ultra-violet and of temperature in separate experiments and did not consider the effects of temperature in conjunction with ultra-violet radiation. Stevens (173) regarded the rise in temperature of a culture during irradiation as unimportant with regard to its effect on spore production. Smith (169) found, however, that the number of spores produced by *Fusarium Eumartii* can be so increased with a 2-min. exposure to ultra-violet in the absence of a temperature control that the whole culture becomes distinctly blue in color. The blue color is due to diffraction by a very large number of spores and not to pigmentation. The blue color was not obtained when the cultures were irradiated in ice water or in a water bath at room temperature. With this fungus, at least, an accurate measure of spore production under the influence of ultra-violet radiation cannot be obtained without temperature control.

Ultra-violet radiation may not only increase the number of spores produced but may also hasten their formation. When the spectrum of

the full mercury arc was used, Hutchinson and Ashton (79) found that sporulation in *Colletotrichum phomoides* is earlier with short exposures but later with longer exposures. They observed that the time of sporulation is an inverse expression of the growth rate only within certain limits. They used a monochromator to study the effects of specific wave-lengths, but since no measurements of intensity were made, the effects produced by different spectral lines are not comparative.

Abscission and Discharge.—Light produces very different effects on the abscission of spores in different fungi. Coemans (cf. Elfving, 39) in 1859 and Brefeld (15) somewhat later were among the first to notice that the discharge of spores in *Pilobolus* can be delayed by placing the fungus in the dark. Since that time the same has been shown to apply to *Ascobolus*, slime molds, and *Coprinus* by deBary (3), Hofmeister (74a), and Buller (19), respectively. Buller found, however, that if the fruiting bodies of *Coprinus* receive light daily, they do not require light on the day of the expansion of the pileus and will produce spores and shed them in the dark at the normal rate. Some attempts have been made to determine which wave-lengths are important in the discharge of spores. Kraus (95), Regel (155), and Jolivette (84) have all reported that blue light is the most effective but that other wave-lengths will cause spore discharge to a lesser degree.

Germination.—Qualitative studies of the effects of sunlight on the germination of spores were made in 1860 by Hoffman (74) and by many others since that time (3, 19, 38, 50, 90, 100, 116, 167, 182, 188, 191, 193). In general, fungus spores apparently germinate just as well without light and will not germinate in too strong light. Light received by spores may affect the percentage germination, the time required for germination, and even the ultimate growth of the culture, but it does not, in general, affect the morphology of the hyphae produced.

The inhibitory effect as measured by the percentage germination is directly proportional to the intensity of radiation once a minimum intensity is reached. This was emphasized by Schulze (167), Luyet (110), and Rabinovitz-Sereni (151). However, as both Luyet (111) and Smith (168) have more recently pointed out, the proportionality does not hold for large as well as small doses, as shown by the S-shaped survival curves which they obtained.

The data which have accumulated indicate that in general the percentage germination decreases as the wave-length decreases throughout the visible and ultra-violet spectrum. Sorokin (171) and Klein (90) both using liquid filters showed that blue light is the most inhibitory of the visible spectrum. Laurent (100) placed spores behind screens of quinine sulfate and found that ultra-violet is more inhibitory than visible radiation. Bovie (13, 14) using wave-lengths ranging from the longest of the ultra-violet to those of less than 1700 \AA concluded that destructive action in the ultra-violet increases as the wave-length decreases. Certain

wave-lengths in the ultra-violet may increase rather than decrease the percentage germination. This was shown by Hutchinson and Ashton (79) who worked with *Colletotrichum phomoides* and a quartz monochromator. However, since there were no measurements made of the intensities used, it is impossible to tell whether the variations produced by different spectral lines were caused entirely by changes in wave-length.

Color may form a protective screen against the harmful effects of light. The results of Bie (7), Bovie (14), Dillon-Weston (32), Rabinovitz-Sereni (151), and Chavarria and Clark (24) in which the sensitivities of different colored spores were compared all support the theory advanced by Chavarria and Clark that pigment in colored spores protects the spores against the destructive action of light by partial absorption of the destructive rays.

This same theory has been advanced as a possible explanation for the differences in susceptibility of mycelium and spores. The comparisons made by Schulze (167), Fulton and Coblenz (54), and Elfving (39) indicate that the mycelium is more sensitive than resting spores. Smith (168), however, reported that this does not apply to *Fusarium Eumartii* since the mycelium is less sensitive to ultra-violet than the spores, and germinating spores are no more sensitive than resting spores. This fungus, however, has colorless mycelium and spores. This does not imply that pigment has no effect, but merely that some other factor must be assumed to explain the data which have accumulated on the relative sensitivity of spores and mycelium.

There is some question as to the importance of age in the susceptibility of spores to radiation. Sibia (cf. Rabinovitz-Sereni, 151) and Smith (168) both noted no effects of age, but Luyet (109) found that young spores are prevented from germinating with much smaller doses than the older ones. Possibly these differences are characteristic of the different species used.

The medium in which the spores are suspended influences to a large degree the amount of inhibition. Both the optical and chemical properties of the medium are important. Dillon-Weston (32) reported that spores of *Puccinia graminis tritici* are killed more easily by ultra-violet from a quartz-mercury-vapor lamp when irradiated in water than when irradiated dry. This might be explained by the fact that a larger amount of light is scattered from dry spores, whereas this effect is largely eliminated when the irregularities on the spore surface are filled with water. Houghton and Davis (cf. Fairhall and Bates, 44) could not obtain more than 20 per cent destructive action of ultra-violet on aqueous suspensions of *Aspergillus* spores whereas Fairhall and Bates (44) readily killed *Aspergillus* spores suspended in an oil emulsion with an exposure of 1 min. to ultra-violet. Both of these investigations were made with a quartz-mercury-vapor lamp. Most oils fluoresce and the secondary

light emitted is usually of shorter wave-length and consequently has greater lethal properties. This might possibly be an explanation of the different results obtained by Houghton and Davis, and Fairhall and Bates. Pichler and Wober (146) working with *Tilletia* as well as Petri (144) working with *Microsphaera* reported that a slightly acid medium augments lethal action while a slightly alkaline medium diminishes it.

Few workers have taken into account the possible effects of temperature changes during irradiation of spores. Becquerel (4) showed what large effects extremes of temperature may have when he exposed *Aspergillus*, *Sterigmatocystis*, and various *Mucor* spores to ultra-violet radiation both at room temperature and at the temperature of liquid air. It took 15 times as long to kill at the temperature of liquid air. Smith (168) irradiated *Fusarium* spores with ultra-violet at temperatures ranging from 0° to 50°C. At zero degrees the survival curves are sigmoid, but they rapidly approach the logarithmic type as the temperature is increased. The spores are somewhat more sensitive at the higher temperatures. The average temperature coefficient between 0° and 40°C. is 1.13, and between 40° and 50°C. it is 1.37. These coefficients are characteristic of a physical or photochemical reaction. The higher temperature coefficient between 40° and 50°C. may indicate that temperature has not merely a sensitizing effect but also a lethal effect in conjunction with ultra-violet radiation. These experiments show that while temperature has little effect within rather narrow limits on the inhibitive effects of radiation, extremes of temperature do play an important role. They also show that temperature and radiation cannot be considered as separate factors.

It has already been mentioned that radiation may affect the time required for germination and also the ultimate growth of the culture. Buller (19) and Hutchinson and Ashton (79) showed that radiation may markedly retard germination, the amount increasing with the exposure. Hutchinson and Ashton (79) also showed that the cultures from germinated spores may have a subnormal growth rate which gradually approaches the normal. Luyet (111) reported that when the lengths of mycelium developed by spores of *Rhizopus nigricans* irradiated with monochromatic light are plotted against the exposure, the curve is approximately logarithmic.

MUTATIONS AND SALTATIONS

The changes in fungi which have been described thus far as due to the influence of light have not been heritable. They have been in no sense mutations. Stevens (177), however, reported that under the influence of ultra-violet radiation from a quartz mercury arc *Glomerella cingulata* produces mutations by sectoring. Dickson (29) exposed cultures of *Chaetomium cochliodes* on malt agar at a distance of 26 cm.

from a mercury-vapor lamp for 50 min. An average of 13 saltants was produced for each 100 colonies subcultured. Most of the saltants showed no tendency to vary, even though many of them were cultured through several generations. There is no essential difference between the characters exhibited by saltants induced by X-rays and those induced by ultra-violet radiation.

PHYSIOLOGICAL PROPERTIES

Respiration, Transpiration, and Synthetic Processes.—There is still some doubt as to the possible effects of radiation on the respiration of fungi. Detmer (28), Elfving (39), and Löwschin (107) all reported no effects. Bonnier and Mangin (11), however, made extensive study of a number of fungi under controlled temperature conditions and found that respiration is retarded by radiation. This retardation may have been masked in the earlier work by the acceleration produced by a rise in temperature when temperature was not controlled. The problem is complicated, however, by the results of Suránji and Vermes (184) which indicate a temporary increase in respiration. No mention is made of any temperature control so that the acceleration may again be due to temperature. Maximow (118) found that age may be a factor. He reported that light from an electric lamp exerts no influence on the respiration of young cultures of *Aspergillus niger*, but it furthers the respiration of older cultures. With regard to the effective wave-lengths, Bonnier and Mangin found that the blue end of the sun's spectrum causes more carbon dioxide to be released than the red.

According to Bonnier and Mangin (11), transpiration is accelerated by diffuse light when the water loss from a number of different fungi was studied under constant temperature conditions. The synthetic processes in fungi were reported by Elfving (39) to be retarded by light, especially by blue light.

Fermentation.—A number of investigations have been made to determine the effects of light on the fermentation activities of yeast in the making of wine and beer (36, 42, 45, 46, 47, 48, 49, 62, 63, 73, 108, 113, 114, 115, 117, 144). In view of the difficult conditions under which most of this work was done, it would be hazardous to discuss it critically.

X-RAYS

It has been rather conclusively shown that X-rays exert positive effects on green plants. The evidence is not so convincing perhaps for the fungi, but nevertheless there have been a number of clear-cut experiments in which definite effects of X-rays have been observed.

Some explanation, however, seems to be necessary for the large number of negative results which have been obtained. In some cases perhaps too small intensities were used. This is a possible explanation

for the negative results obtained by Errera (41), Atkinson (1), Berde (5), and Johnson (83). In the cure of certain skin diseases caused by fungi such as athlete's foot and actinomycosis it has been frequently observed that X-rays produce a cure only in certain individuals. The reasons for this difference are not known but the difference may explain why such workers as Lieske (105) and Kleesattel (89) noted no effects of X-rays on actinomycosis, whereas Melchior (120), Levy (104), Sardemann (160), and Jüngling (85) reported positive results.

The effects of X-rays on fungi are similar in many respects to those which have been reported for green plants. The most conspicuous of these, possibly, is lethal action. Fungi are rather insensitive to X-rays, but large doses produce killing effects. Neidhart (137) was among the first to note lethal action with X-rays. S-shaped survival curves were obtained by Wyckoff and Luyet (196), Luyet (111), and Glocker, Langendorff, and Reuss (58). Lacassagne and Holweck (97) found that the sensitivity of *Saccharomyces* to soft X-rays is the same for a definite quantity of X-rays regardless of the time and intensity. Very little study has been made of the effects of different wave-lengths. Haskins and Moore (68), however, found that the soft X-rays which they used were 2.1 times as effective in killing *Penicillium* spores as hard X-rays. The soft X-rays were very nearly monochromatic and were composed chiefly of wave-lengths of 1.5 to 1.3 Å, while the hard radiation had its greatest intensity between 0.21 and 0.18 Å. Careful measurements were made of intensities. The lethal action of X-rays becomes of some practical import in the irradiation of fungi inside of seeds and fruits. Pichler and Wöber (146) succeeded in killing *Ustilago Tritici* in the seeds of wheat, *U. nuda* in the seeds of barley, and *Chrysophlyctis endobioticum* in potato tubers. They found that X-rays are much more effective than ultra-violet rays for this purpose because of their greater penetrating power.

Various degrees of injury are produced by X-rays just as by ultra-violet. Yeast loses its ability to multiply with much smaller doses than are required for immediate killing. Such doses may merely retard division or they may cause the production of giant cells which have lost their ability to divide. Some cells may divide only once following irradiation. These various injurious effects have been emphasized by Lacassagne (96), Holweck and Lacassagne (77), Wyckoff and Luyet (196), and Holweck (75).

The effects of small doses thus far discussed have been either negative or slightly injurious. Lacassagne and Holweck (97) and Wyckoff and Luyet (196) found no evidence of stimulation with small doses of X-rays on yeasts, but Zeller (197) found that under certain circumstances fermentation is temporarily increased. Nadson (131) noted that small doses of X-rays may so stimulate the metabolic processes of the cell as to cause

the cell to become old prematurely. This last statement is in accord with evidence obtained from the higher plants, but as for the fungi there is some question as to whether a stimulation of total growth can be obtained with X-rays.

The metabolic state of the cell, its reproductive activity, as well as the composition of the surrounding medium, all affect the sensitivity of the cell to X-rays. Lacassagne and Holweck (97) reported that yeast cells in a quiescent state are more sensitive to X-rays than actively dividing cells. This is in accord with the generally accepted theory that quiescent cells in general are more sensitive to radiation than cells in division. Schneider (165) found that yeast cells which are causing active fermentation in a sugar solution are much more sensitive to X-rays than those which are irradiated dry. A number of investigators have reported that the sensitivity of the fungus cell is increased markedly by the addition of an electrolyte to the medium. Schneider (165), Groedel and Schneider (60), and Zeller (197) have noted the sensitizing action of a number of different salts. Pichler and Wöber (146) reported that the action of X-rays on spores of *Ustilago Tritici* and *Chrysophlyctis endobioticum* is greatly increased if the spores are irradiated in an acid medium, especially in the presence of oxygen or of oxygen-yielding compounds. Increased sensitivity produced by a change in medium has been interpreted as due to the production of harmful ions by radiation or as due to increased permeability of the fungus cell as a result of irradiation. Both of these factors are probably involved, but at the present time there is little more that can be said about the nature of the sensitization. Some salts may decrease instead of increase sensitization. The antagonistic action of potassium chloride to the aging effects of X-rays is exceedingly interesting from both a theoretical and a practical point of view. It was observed by Nadson and Žolkevič (136) that the harmful influences of X-rays on yeast may be entirely eliminated if 0.5 to 1.5 per cent potassium chloride is added to the substrate. They found that the antagonism is dependent on a definite ratio between the amount of potassium and the intensity of X-rays. Sodium chloride does not exert such a balancing effect.

Saltation is another interesting effect produced by X-rays. Nadson and Philippov (133) and Dickson (29, 30) reported saltants produced in this way. The characters of some of the saltants remained constant through a number of succeeding generations. Nadson and Philippov used *Mucor* and Dickson used *Phycomyces Blakesleanus* and several species of *Chaetomium*. Dickson found that different species in the same genus vary markedly in their ability to saltate when exposed to X-rays. He also reported that old cultures saltate much more readily than younger ones. Little correlation was found between the normal variability of the fungus and its capacity to produce saltants with X-rays.

The ability to form sexual organs can be destroyed by X-rays, but the ability to form asexual organs is not so readily suppressed. Nadson and Philippov (133) completely suppressed the formation of zygotes in *Mucor genevensis* and *Zygorhynchus Moelleri*, but they could never entirely prevent the formation of sporangia.

RAYS EMITTED FROM RADIOACTIVE SUBSTANCES

Studies which have been made of the effects of rays from radioactive substances on fungi have yielded only fragmentary evidence. However, much of it is interesting as a basis for further detailed study. There is no question but that the rays produce effects on fungi provided the dose is sufficiently great. Although no effects were noted by Prescott (149), the preponderance of evidence indicates marked inhibitory action with large doses.

If the dose is sufficiently great, lethal action occurs. This was reported by Purvis and Warwick (150), Nadson (130), Lacassagne (96), Levin and Levine (103), Miescher (121), Heyderdahl (72), and Glocker, Langendorff, and Reuss (58). Heyderdahl was successful in curing severe cases of facial actinomycosis with gamma rays from radium. According to Glocker, Langendorff, and Reuss lethal action follows a typical S-shaped survival curve when yeast cells are treated with alpha rays from a polonium preparation. The approximate dose necessary to kill yeast cells in beer is expressed by Lacassagne as one in which each square micron receives an alpha particle from polonium once every 4.35 sec. He reported that the cells died after one division. Miescher found that a 10- to 14-day exposure to 24.9 mg. of radium with a silver filter 0.1 mm. in thickness and placed at a distance of 15 mm. from the culture is necessary to stop the growth of *Achorion gypseum*. Lacassagne and Holweck (97) reported that the amount of lethal action is dependent on the total number of alpha particles regardless of the time or the intensity, and Holweck (75) calculated that about 20 times as much energy is necessary to prevent the first as to prevent the second division following irradiation. Nadson (130) observed that there is a latent period following irradiation during which no effect is visible, the length of the period depending on the exposure. He found that, in general, young cultures are more sensitive than older ones, while Lacassagne and Holweck (97) found that cells in a quiescent state are more sensitive than actively dividing cells. Nadson and Žolkevič (136) found, as they had for X-rays, that the harmful action of the rays from radium can be almost balanced by the addition of potassium chloride to the substrate. The antagonism is dependent on a definite ratio between the intensity of radiation and the concentration of potassium chloride.

Various degrees of injury similar to those produced by other regions of the spectrum are produced with sublethal exposures to radioactive

substances. Retardation of vegetative growth was reported by Dauphin (27), Dautwitz (cf. Stoklasa and Penkava, 181), Fabre (43), Miescher (121), Rivera (158), Johnson (83), and Nadson (130). Rather interesting morphological changes in the hyphae have been observed with sublethal doses. Nadson (132) reported that the protoplasm becomes less transparent, granulation occurs, many vacuoles appear, and there is an increase in size of the cells. Yeasts form cysts which are not affected by the rays. Similar though less detailed observations were made by Dauphin (27), Purvis and Warwick (150), and Kotzareff and Chodat (94).

Kotzareff and Chodat (94), Nadson (131), and Fabre (43) all reported that small doses stimulate cell division at least temporarily. Nadson considered the action of radium as an aging process which accelerates the vital processes and brings about a premature death of the cell. This is in accord with a number of observations made on green plants. Lacassagne (96) was unable to observe any stimulation of the growth of yeast cells, owing, possibly, either to the doses which were used or to the method of measuring stimulation.

Sartory, Sartory, and Meyer have published a series of papers on the effects of radium on the fruiting bodies of *Aspergillus fumigatus* and *Mucor spinosus*. They reported that in a "dissociated" medium radiation stimulates the formation of fruiting structures in *A. fumigatus* especially if irradiation is discontinuous, whereas if the medium is "undissociated" there is a delay in the appearance of normal fruiting bodies (161). They found that if this fungus is grown on gelatinized carrot juice (pH 4.7) dissociated by sodium chloride, it produces asci and ascospores under the action of radium (162). They were also able to cause the production of sex organs in *M. spinosus* on the same medium (163).

Ceresoli (23), Dautwitz (cf. Stoklasa and Penkava, 181), Fabre (43), and Ingber (82) all reported a retardation or partial suppression of spore production by radiation. Ingber reported in addition that small doses may stimulate spore production.

Retardation or complete suppression of spore germination by radiation was reported by Sartory, Sartory, and Meyer (163), Dautwitz (cf. Stoklasa and Penkava, 181), Fabre (43), Pichler and Wöber (146), and Dauphin (27). Sartory, Sartory, and Meyer found that spores resist much higher doses of radiation if the medium is dissociated by thorium. Neidhart (137) reported that smaller doses of radium are necessary to kill the germinating than the resting spores of *Sporotrichum Beurmanni*.

Studies have been made of the effects of the rays emitted by radioactive substances on various physiological processes in fungi. Stoklasa (180) reported that respiration is increased and Stoklasa and Penkava (181) later found that while respiration is increased by alpha radiation, it is decreased by gamma or by a mixture of beta and gamma radiations.

Kotzareff and Chodat (94) reported that radiation retards fermentation while Stoklasa (180) and Kayser and Delaval (86) found that small amounts stimulate it. Differences in results are probably caused by the different conditions under which the experiments were performed and the different amounts of radiation to which the cultures were exposed. Nadson (130) reported that *Cryptococcus* which normally does not produce glycogen, after irradiation forms glycogen and another carbohydrate which stains blue or violet with an iodide. Sartory, Sartory, and Meyer (161) found that in an "undissociated" medium irradiation increases the ability of *Aspergillus fumigatus* to reduce saccharose, while in a "dissociated" medium irradiation decreases it. Suguira and Benedict (183) found that the vitamins in yeast can be partially inactivated by exposure to radon. A positive tropism of the sporangiophores of *Phycomyces nitens* to radium after 15 or more hours' exposure was reported by Koernicke (92) and Molisch (123). A rather unusual phenomenon was noted by Guyot (64) who found that a tube of radium applied to a mycelium which is normally phosphorescent but whose phosphorescence has been recently extinguished revives the luminosity. If the mycelium is already luminous and the radium is allowed to act for 2 or 3 hr., the luminosity is gradually destroyed.

GENERAL SUMMARY

One of the most outstanding criticisms which might be made of radiation experiments is that the results cannot be easily duplicated. The wave-lengths emitted by the source, the intensity of the source, the nature of any absorbing media interposed, temperature, composition of the medium, hydrogen ion concentration, age of the culture, and inoculation technique must all be measured in standard units in order to have results which may be easily confirmed by other workers. Various experiments have shown that all these factors may affect the sensitivity of fungi to radiation.

Different wave-lengths have been obtained by varying the source and by interposing various absorbing media between the source and the fungus. Often, however, all the absorbing media interposed have not been considered in determining the wave-lengths which the culture received. Cultures placed behind a window do not receive the same sunlight as those placed outside. Water and solid nutrient media absorb radiation selectively with respect to wave-length, so that not only the total intensity but also the quality of the light may be altered. Fungus hyphae may act as an absorbing screen to those hyphae growing below them. For still more quantitative considerations of wave-length there are multiple reflections from the fungus mycelia and from the medium.

It is quite difficult to control adequately temperature in radiation experiments, especially where the intensities of radiation are large.

There is no good literature on the effects of sudden changes in temperature on fungi, and it may be that very slight sudden changes may produce very pronounced results. In the problem of temperature not only infrared radiation emitted by the source but also light absorbed by the fungus and by the medium and transformed to heat must be considered. This effect can be minimized somewhat by the use of liquid media and a water bath whose temperature is regulated. However, in many instances a liquid medium is not desirable since it often leads to a thicker mycelial mat.

The vigor of the fungus as affected by its age, nutrition, acidity, and previous light treatment probably determines very largely its sensitivity to radiation. If the effect of light on a fungus in which there are no other limiting factors is to be considered, then preliminary experiments should be made to establish the fact that other conditions are favorable.

Because environmental factors have been so largely neglected in the experiments, there are very few general conclusions which may be drawn. It has been well established that some fungi will carry on a normal life cycle in complete darkness. Others need light for different stages in their development. Most fungi require light for the formation of large amounts of pigment. Short wave-lengths are in general more harmful to vegetative development than long wave-lengths. But even such generalizations as these may be open to question. It seems quite certain that a great many phenomena which have been attributed to the action of light are due not to light alone but to light linked with some other varying environmental factor.

REFERENCES

1. ATKINSON, G. F. Report upon some preliminary experiments with the Röntgen rays on plants. *Science* **7**: 7-13. 1898.
2. BAILEY, A. A. Effects of ultraviolet radiation upon representative species of *Fusarium*. *Botan. Gaz.* **94**: 225-271. 1932.
3. BARY, A. DE. Recherches sur le développement de quelques champignons parasites. *Ann. Sci. Nat. Bot. Ser.* **4**, **20**: 5-148. 1863.
4. BECQUEREL, P. L'action abiotique de l'ultraviolet et l'hypothèse de l'origine cosmique de la vie. *Compt. Rend. Acad. Sci. [Paris]* **151**: 86-88. 1910.
5. BESSE, K. VON. Das Verhalten von Fadenpilzkolonien unter der Wirkung des Lichtes. *Arch. Dermatol. und Syphilis* **158**: 35-50. 1929.
6. BESSEY, E. A. Über die Bedingungen der Farbbildung bei *Fusarium*. *Flora* **93**: 301-334. 1904.
7. BIE, V. Über das Vermögen des Lichtes Spross, und Schimmelpilze zu töten. *Mitt. Finsen's Med. Lysin.* **1**: 78-88. 1900.
8. BISBY, G. R. Zonation in cultures of *Fusarium discolor sulphureum*. *Mycologia* **17**: 89-97. 1925.
9. BLAAUW, A. H. Licht und Wachstum I. *Zeitschr. Bot.* **6**: 641-703. 1914.
10. BLAAUW, A. H., and W. VAN HEYNINGEN. De radiumgroeireactie van een cel. *Koninklijke Akad. Wetensch. [Amsterdam] Afdeling natwetkunde* **34** (1): 173-188. 1925.
11. BONNIER, G., and L. MANGIN. Recherches sur la respiration et la transpiration des champignons. *Ann. Sci. Nat. Bot. Ser.* **6**, **17**: 210-305. 1884.

12. BONORDEN, H. F. Handbuch der allgemeinen Mykologie. Stuttgart, 1851.
13. BOVIE, W. T. The action of light on protoplasm. Amer. Jour. Trop. Dis. **2**: 506-517. 1914.
14. BOVIE, W. T. The action of Schumann rays on living organisms. Botan. Gaz. **61**: 1-29. 1916.
15. BREFELD, O. Die Bedeutung des Lichtes für die Entwicklung der Pilze. Bot. Zeitsch. **35**: 386. 1877.
16. BREFELD, O. Untersuchungen aus dem Gesamtgebiete der Mykologie. Arthur Felix. Leipzig, 1877-1879. **3**: (Cf. pp. 87-97, 114-116); **4**: (Cf. pp. 76-81); **8**: (Cf. pp. 275-290).
17. BROWN, W. Studies in the genus *Fusarium*. II. An analysis of factors which determine the growth-forms of certain strains. Annals Bot. **39**: 375-408. 1925.
18. BUCHTA, L. Über den Einfluss des Lichtes auf die Sprossung der Hefe. Centralbl. Bakt. 2. Abt. **41**: 340-351. 1914.
19. BULLER, A. H. R. Researches on fungi. Longmans Green. London, 1909-1931. **1**: (Cf. pp. 47-78, 120-121); **3**: (Cf. pp. 311-312); **4**: (Cf. pp. 104-117, 121-126).
20. CARNOY, J. B. Recherches anatomiques et physiologiques sur les champignons. Bull. Soc. Roy. Bot. Belgique **9**: 157-321. 1870.
21. CASTLE, E. S. Dark adaptation and the light-growth response of Phycomyces. Jour. Gen. Physiol. **12**: 391-400. 1929.
22. CASTLE, E. S. Dark adaptation and the dark growth response of Phycomyces. Jour. Gen. Physiol. **16**: 75-88. 1932.
23. CERESOLI, G. Ricerche sull' azione del radium rispetto alle muffe patogene e non patogene. Boll. dell' ordine dei medici della città e provincia di Venezia Anno I. 1904. (Seen only in abstract. Centralbl. Bakt. 2. Abt. **39**: 607-608. 1907.)
24. CHAVARRIA, A. P., and J. H. CLARK. The reaction of pathogenic fungi to ultra-violet light and the role played by pigment in this reaction. Amer. Jour. Hyg. **4**: 639-649. 1924.
25. COONS, G. H. Factors involved in the growth and the pycnidium formation of *Plenodomus fuscomaculans*. Jour. Agr. Res. **5**: 713-769. 1916.
26. COONS, G. H., and E. LEVIN. The relation of light to pycnidium formation in the Sphaeropsidales. Michigan Acad. Sci. Ann. Rept. **22**: 209-213. 1920.
27. DAUPHIN, J. Influence of radium on the development and growth of the lower fungi. Nature **69**: 311. 1904.
28. DETMER, W. System der Pflanzenphysiologie. Schenk's Handbuch der Botanik. **2**: 1-159. 1882.
29. DICKSON, H. The effects of X-rays, ultra-violet light, and heat in producing saltants in *Chaetomium cochliodes* and other fungi. Annals Bot. **46**: 389-405. 1932.
30. DICKSON, H. Saltation induced by X-rays in seven species of *Chaetomium*. Annals Bot. **47**: 735-754. 1933.
31. DILLON-WESTON, W. A. R. Effect of light on urediniospores of black stem rust of wheat, *Puccinia graminis tritici*. Nature **128**: 67-68. 1931.
32. DILLON-WESTON, W. A. R. Effect of ultra-violet radiation on the uredospores of some physiologic forms of *Puccinia graminis tritici*. Sci. Agron. **12**: 81-87. 1931.
33. DILLON-WESTON, W. A. R. III. Studies on the reaction of disease organisms to light. The reaction of disease organisms to certain wave-lengths in the visible and invisible spectrum. Sci. Agron. **12**: 352-356. 1932.
34. DILLON-WESTON, W. A. R., and E. T. HALNAN. The fungicidal action of ultra-violet radiation. Phytopath. **20**: 959-965. 1930.

35. DOWNES, A., and T. P. BLUNT. Researches on the effect of light upon bacteria and other organisms. *Proc. Roy. Soc. [London]* **26**: 488-500. 1877.
36. DUMAS. Recherches sur la fermentation alcoolique. *Ann. Chim. et Phys. Ser. 5*, **3**: 57-108. 1874.
37. EHRLSMANN, O., and W. NOETHLING. Über die bakterieide Wirkung monochromatischen Lichtes. *Zeitsch. Hyg.* **113**: 597-628. 1932.
38. ELFVING, F. Ueber Saccharomyces glutinis (Fresen.) Cohn. *Öfv. Finska Vetensk. Soc. Förhandl.* **28**: 28-35. 1886.
39. ELFVING, F. Studien über die Einwirkung des Lichtes auf die Pilze. *Helsingfors*, 1890.
40. ELLIS, M. Some experimental studies on *Pleospora herbarum* (Pers.) Rabenh. *Trans. British Myc. Soc.* **16**: 102-114. 1931.
41. ERRERA, M. L. Expériences relatives à l'action des rayons X sur un *Phycomyces*. *Compt. Rend. Acad. Sci. [Paris]* **122**: 787. 1896.
42. EULER, H. VON, and I. LAURIN. Verstärkung der Katalasewirkung in Hefezellen II. *Hoppe-Seyler's Zeitschr. f. Physiol. Chem.* **106**: 312-316. 1919.
43. FABRE, G. Effets de l'activation de l'atmosphère par l'émanation du radium sur la germination et la poussée de divers organismes végétaux. *Compt. Rend. Soc. Biol. [Paris]* **70**: 187-188. 1911.
44. FAIRHALL, L. T., and P. M. BATES. The sterilization of oils by means of ultra violet rays. *Jour. Bact.* **5**: 49-66. 1920.
45. FAZI, R. DE. Azione dei raggi ultravioletti sue *Saccharomyces cerevisiae*. *Atti R. Accad. Lincei Roma Rendiconti Cl. Sci. Fis. Mat. e Nat.* **31**: 31-32. 1922.
46. FAZI, R. DE. Fermentazione alcoolica di soluzioni di glucosio con acqua esposta alle radiazioni di una lampada a vapori di mercurio. *Atti d. R. Accad. nazionale d. Lincei. Rend. Ser. 6*, **5**: 901-905. 1927.
47. FAZI, R. DE, and R. DE FAZI. Azione dei raggi ultravioletti sulla fermentazione alcoolica des mosto di fico d'India. *Ann. d. Chim. Appl. [Rome]* **8**: 93-99. 1917.
48. FAZI, R. DE, and R. DE FAZI. Action of ultra-violet rays on *Saccharomyces cerevisiae*. *Giornale d. Chim. Ind. ed Appl. [Milan]* **4**: 463-464. 1922.
49. FAZI, R. DE, and R. DE FAZI. Action of ultraviolet rays on alcoholic fermentation and on yeast. *Atti Congr. Naz. Chim. Ind.* 449-450. 1924.
50. FERGUSON, M. C. A preliminary study of the germination of the spores of *Agaricus campestris* and other Basidiomycetous fungi. *U. S. Dept. Agric. Bur. Plant Ind. Bull.* 16. 1902.
51. FEUER, B., and F. W. TANNER. The action of ultraviolet light on the yeast-like fungi. *Jour. Indust. Eng. Chem.* **12**: 740-741. 1920.
52. FRIES, E. *Systema Mycologicum*. Vol. 1. Ernesti Mauriti, Gryphiswaldae, 1821.
53. FULLER, H. J. Some effects of radiations from a mercury vapor arc in quartz upon enzymes. *Ann. Missouri Botan. Gard.* **19**: 505-531. 1932.
54. FULTON, H. R., and W. W. COBLENTZ. The fungicidal action of ultra-violet radiation. *Jour. Agric. Res.* **38**: 159-168. 1929.
55. GAISBERG, E. v. Studien über den Larchenkrebsspilz, *Dasysephypha Willkommii*, insbesondere über die Keimung seiner Sporen. *Centralbl. Bakt.* 2 Abt. **73**: 206-233. 1928.
56. GALLEMAERTS, V. De la zonation des cultures de champignons en boîte de Pétri. *Rec. Inst. Bot. Léo Errera* **8**: 213-223. 1911.
57. GIUNTI, M. Azione della luce sulla fermentazione. *Rivista di vitocoltua ed enologia italiana. Botan. Jahresber.* **12**(1): 27-28. 1884.
58. GLOCKER, R., H. LANGENDORFF, and A. REUSS. Über die Wirkung von Röntgenstrahlen verschiedener Wellenlänge auf biologische Objekte III. *Strahlentherapie* **46**: 517-528. 1933.

59. GRÄNTZ, F. Ueber den Einfluss des Lichtes auf die Entwicklung einiger Pilze. Dissertation. Leipzig, 1898.
60. GROEDEL, F. M., and E. SCHNEIDER. Experimentelle Untersuchungen zur Frage der biologischen Wirkung der Röntgenstrahlen. *Strahlentherapie* **23**: 411-446. 1926.
61. GROXCHI, V. Azione dei raggi ultravioletti sulla fermentazione alcoolica del *Saccharomyces cerevisiae*. I. *Boll. Soc. Ital. Biol. Sperim.* **7**: 951-960. 1932.
62. GROXCHI, V. Azione dei raggi ultravioletti sulla fermentazione alcoolica del *Saccharomyces cerevisiae*. II. *Boll. Soc. Ital. Biol. Sperim.* **7**: 961-963. 1932.
63. GUERRINI, G. Influenza delle luci monocromatiche sull' azione del *Saccharomyces cerevisiae* in presenza di glucosio. *Boll. Soc. Ital. Biol. Sperim.* **5**: 635-636. 1930. (Seen only in abstract. *Biol. Abst.* **6**: 15620. 1932.)
64. GUYOT, R. Microbes et champignons phosphorescents. *Parallelisme. Rev. Gén. Sci. Pures et Appl.* **39**: 113-116. 1928.
65. HALL, M. P. An analysis of the factors controlling the growth form of certain fungi, with especial reference to *Sclerotinia* (*Monilia*) *fructigena*. *Annals Bot.* **47**: 543-578. 1933.
66. HARTER, L. L. The foot-rot of the sweet potato. *Jour. Agric. Res.* **1**: 251-273. 1913.
67. HARTER, L. L. Pod blight of the lima bean caused by *Diaporthe phascolorum*. *Jour. Agric. Res.* **11**: 473-504. 1917.
68. HASKINS, C. P., and C. N. MOORE. The inhibition of growth in pollen and mold under X-ray and cathode ray exposure. *Radiology* **23**: 710-719. 1934.
69. HEDGCOCK, G. G. Zonation in artificial cultures of *Cephalothecium* and other fungi. *Rept. Missouri Botan. Gard.* **17**: 115-117. 1906.
70. HELDMAIER, C. Über die Beeinflussbarkeit der Sexualität von *Schizophyllum commune* (Fr.) und *Collybia velutipes* (Curt.). *Zeitsch. Bot.* **22**: 161-220. 1929.
71. HEY, G. L., and J. E. CARTER. The effect of ultra-violet light radiation on the vegetative growth of wheat seedlings and their infection by *Erysiphe graminis*. *Phytopath.* **21**: 695-699. 1931.
72. HEYDERDAHL, S. A. Actinomycosis of the face and neck treated with radium. *Brit. Jour. Radiol.* **31**: 1-14. 1926.
73. HINRICHS, M. A. Ultraviolet radiation; stimulation and inhibition in lower organisms. *Proc. Soc. Exper. Biol. and Med.* **26**: 175-177. 1928.
74. HOFFMAN, H. Untersuchungen über die Keimung der Pilzsporen. *Jahrb. Wiss. Bot.* **2**: 267-337. 1860.
- 74a. HOFMEISTER, W. Die Lehre von der Pflanzenzelle. Wilhelm Engelmann; Leipzig, 1867.
75. HOLWECK, F. Étude énergétique de l'action biologique de diverses radiations. *Compt. Rend. Acad. Sci. [Paris]* **190**: 527-529. 1930.
76. HOLWECK, F. Interpretation quantique de la radiosensibilité cellulaire. *Congrès Internat. Élect. [Paris] Report 5. Section 10. Pp. 1-15.* 1932.
77. HOLWECK, F., and A. LACASSAGNE. Action sur les levures des rayons X mous (K du fer). *Compt. Rend. Soc. Biol. [Paris]* **103**: 60-62. 1930.
78. HOUGHTON, E. M., and L. DAVIS. A study of the germicidal action of the ultra-violet rays. *Amer. Jour. Publ. Health* **4**: 224-240. 1914.
79. HUTCHINSON, A. H., and M. R. ASHTON. The effect of radiant energy on growth and sporulation in *Colletotrichum phomoides*. *Canadian Jour. Res.* **3**: 187-198. 1930.
80. HUTCHINSON, A. H., and D. NEWTON. The specific effects of monochromatic light on the growth of yeast. *Canadian Jour. Res.* **2**: 249-263. 1930.
81. HUTCHINSON, H. B. Ueber Form und Bau der Kolonien niederer Pilze. *Centralbl. Bakt. 2 Abt.* **17**: 65-74, 129-136, 321-330, 417-427, 593-604. 1907.

82. INGBER, E. Über die Radiumsensibilität des Actinomycespilzes. *Strahlentherapie* **28**: 581-588. 1929.
83. JOHNSON, F. H. Effects of electromagnetic waves on fungi. *Phytopath.* **22**: 277-300. 1932.
84. JOLIVETTE, H. D. M. Studies on the reactions of *Pilobolus* to light stimuli. *Botan. Gaz.* **57**: 89-121. 1914.
85. JÜNGLING, O. Zur Röntgenbehandlung der Aktinomykose. *Brun's Beitr. Klin. Chirur.* **118**: 105-125. 1919.
86. KAYSER, E., and H. DELAVAL. Radioactivité, fixateurs d'azote et levures alcooliques. *Compt. Rend. Acad. Sci. [Paris]* **181**: 151-153. 1925.
87. KEESER, E. Über die Wirkung verschiedener Lichtarten auf die Glykolyse. *Arch. Exper. Path. und Pharmakol.* **170**: 500-509. 1933.
88. KLEBS, G. Zur Physiologie der Fortpflanzung einiger Pilze III. *Jahrb. Wiss. Bot.* **35**: 80-203. 1900.
89. KLEESATTEL, H. Zur Frage der Röntgenempfindlichkeit des Strahlenpilzes. *Strahlentherapie* **17**: 390-394. 1924.
90. KLEIN, L. Ueber die Ursachen der ausschliesslich nächtlichen Sporenbildung von *Botrytis cinerea*. *Botan. Zeitung* **43**: 6-15. 1885.
91. KNISCHEWSKY, O. Tagesringe bei *Penicillium luteum*. *Landwirtsch. Jahrb.* **38**(5): 341-343. 1909.
92. KOERNICKE, M. Weitere Untersuchungen über die Wirkung von Röntgen- und Radiumstrahlen auf die Pflanzen. *Ber. Deut. Botan. Ges.* **23**: 324-333. 1905.
93. KOSAROFF, P. Beitrag zur Biologie von *Pyronema confluens* Tul. *Arb. Biol. Abt. Land- und Forstwirtsch. Kais. Gesundh.* **5**: 126-138. 1907.
94. KOTZAREFF, A., and F. CHODAT. De l'action exercée par l'émanation du radium sur les levures. *Compt. Rend. Soc. Phys. Hist. Nat. [Genève]* **40**: 36-39. 1923.
95. KRAUS, G. Versuche mit Pflanzen im farbigen Licht. *Botan. Zeitung* **34**: 503-507. 1876.
96. LACASSAGNE, A. Différence de l'action biologique provoquée dans les levures par diverses radiations. *Compt. Rend. Acad. Sci. [Paris]* **190**: 524-526. 1930.
97. LACASSAGNE, A., and F. HOLWECK. Sur la radiosensibilité de la levure *Saccharomyces ellipsoideus*. *Compt. Rend. Soc. Biol. [Paris]* **104**: 1221-1223. 1930.
98. LAKON, G. B. Die Bedingungen der Fruchtkörperbildung bei *Coprinus*. *Annal. Mycol.* **5**: 155-176. 1907.
99. LAURENT, E. Recherches sur le polymorphisme du *Cladosporium herbarum*. *Annales Inst. Pasteur* **2**: 581-603. 1888.
100. LAURENT, E. Influence de la lumière sur les spores du charbon des céréales. *Compt. Rend. Soc. Roy. Bot. Belgique* **28**: 162-164. 1889.
101. LEHMAN, S. G. Pod and stem blight of soybean. *Ann. Missouri Botan. Gard.* **10**: 111-178. 1923.
102. LENDNER, A. Des influences combinées de la lumière et du substratum sur le développement des champignons. *Annales Sci. Nat. Bot.* **3**: 1-64. 1897.
103. LEVIN, I., and M. LEVINE. The action of buried tubes of radium emanation on neoplasias in plants. *Jour. Cancer Res.* **7**: 163-170. 1922.
104. LEVY, R. Röntgenbestrahlung der Aktinomykose. *Centralbl. Chirur.* **40**: 121-122. 1913.
105. LIESKE, R. Morphologie und Biologie der Strahlenpilze. Gebrüder Borntraeger; Leipzig, 1921.
106. LOEW, E. Zur Physiologie niederer Pilze. *Verhandl. Zool. Bot. Gesellsch. Wien* **17**: 643-656. 1867.
107. LÖWSCHIN, A. Zur Frage über den Einfluss des Lichtes auf die Atmung der niederen Pilze. *Beih. Bot. Centralbl.* **23**: 54-64. 1908.

108. LUBIMENKO, W., and A. FROLOFF-BAGREIEF. Influence de la lumière sur la fermentation du moût du raisin. *Compt. Rend. Acad. Sci. [Paris]* **154**: 226-229. 1912.
109. LUYET, B. J. La radiosensibilité à l'ultraviolet chez les Mucorinées en fonction de leur âge. *Compt. Rend. Soc. Phys. Hist. Nat. Genève* **46**: 107-108. 1929.
110. LUYET, B. J. The killing of moulds by an ordinary electric bulb. *Proc. Soc. Exper. Biol. and Med.* **27**: 668-670. 1930.
111. LUYET, B. J. The effects of ultra violet, X-rays and cathode rays on the spores of Mucoraceae. *Radiology* **18**: 1019-1022. 1932.
112. MACDOUGAL, D. T. The influence of light and dark on growth and development. *Mem. N. Y. Bot. Garden* **2**: 1-319. 1903.
113. MACHT, D. I. Photopharmacology V. Influence of sun's rays on growth of yeast in sodium benzoate. *Proc. Soc. Exper. Biol. and Med.* **23**: 638-639. 1926.
114. MACHT, D. I. Photopharmacology VI. Influence of sun's rays on growth of yeast in some fluorescent solutions. *Proc. Soc. Exper. Biol. and Med.* **23**: 639-641. 1926.
115. MACHT, D. I., and J. H. HILL. The influence of polarized light on yeast and bacteria. *Proc. Soc. Exper. Biol. and Med.* **22**: 474-475. 1925.
116. MANGIN, L. Nos auxiliaires et nos défenseurs dans la lutte contra les maladies parasitaires. *Jour. Agr. Prat.* **1**: 746-750. 1896.
117. MARTINAND, V. Influence des rayons solaires sur les levures que l'on rencontre à la surface des raisins. *Compt. Rend. Acad. Sci. [Paris]* **113**: 782-784. 1891.
118. MAXIMOW, N. A. Ueber den Einfluss des Lichtes auf die Atmung der niederen Pilze. *Centralbl. Bakt. 2. Abt.* **9**: 193-205, 261-272. 1902.
119. MCCREA, A. A special reaction to light by the mycelium of *Claviceps purpurea*. *Papers Michigan Acad. Sci.* **9**: 245-252. 1928.
120. MELCHIOR, E. Klinische Erfahrungen über kombinierte Jod-Röntgentherapie der cervico-facialen Aktinomykose. *Berliner Klin. Wochenschr.* **53**: 586-588. 1916.
121. MIESCHER, G. Untersuchungen über das Vorkommen wachstumsfördernder Wirkungen nach Radiumbestrahlung an menschenpathogenen Hyphomyzeten. *Fortsehr. Geb. Röntgenstr.* **33**: 81-84. 1925.
122. MILBURN, T. Ueber Aenderungen der Farben bei Pilzen und Bakterien. *Centralbl. Bakt. 2. Abt.* **13**: 129-138, 257-276. 1904.
123. MOLISCH, H. Über Heliotropismus, indirekt hervorgerufen durch Radium. *Ber. deut. Botan. Ges.* **23**: 2-8. 1905.
124. MOLZ, E. Ueber die Bedingungen der Entstehung der durch *Sclerotinia fructigena* erzeugten "Schwarzfäule" der Aepfel. *Centralbl. Bakt. 2. Abt.* **17**: 175-188. 1907.
125. MOREAU, F. Sur les zones concentriques que forment dans les cultures les spores de *Penicillium glaucum* Link. *Bull. Soc. Bot. France* **59**: 491-495. 1912.
126. MOREAU, M., and F. MOREAU. Sur l'action des différentes radiations lumineuses sur la formation des conidies du *Botrytis cinerea* Pers. *Bull. Soc. Bot. France* **60**: 80-83. 1913.
127. MORRIS, H. E., and G. B. NUTTING. Identification of certain species of *Fusarium* isolated from potato tubers in Montana. *Jour. Agric. Res.* **24**: 339-364. 1923.
128. MÜGGENBURG, S. S. VON. Des allbelebenden Lichtes Einfluss auf die Pilzwelt. *Flora* **61**: 119-124. 1878.
129. MUNK, M. Bedingungen der Hexenringbildung bei Schimmelpilzen. *Centralbl. Bakt. 2. Abt.* **32**: 353-375. 1912.
130. NADSON, G. A. Ueber die Wirkung des Radiums auf die Hefepilze im Zusammenhang mit die Frage des Radiumeinflusses auf die lebendige Substanz im Allgemeinen. *Bull. Inst. Pasteur* **22**: 571-573. 1924.

131. NADSON, G. A. Sur l'accélération du tempo de la vie et la vieillissement prématuré chez les organismes inférieurs sous l'influence des rayons X et du radium. *Compt. Rend. Soc. Biol. [Paris]* **93**: 1585-1586. 1925.
132. NADSON, G. A. Über die Primärwirkung der Radiumstrahlen auf die lebendige Substanz. *Biochem. Zeitsch.* **155**: 381-386. 1925.
133. NADSON, G. A., and G. S. PHILIPPOV. Influence des rayons X sur la sexualité et la formation des mutantes chez les Champignons inférieurs (Mucorinées). *Compt. Rend. Soc. Biol. [Paris]* **93**: 473-475. 1925.
134. NADSON, G. A., and G. S. PHILIPPOV. Action excitante des rayons ultra-violetes sur le développement des levures et des moisissures. *Compt. Rend. Soc. Biol. [Paris]* **98**: 366-368. 1928.
135. NADSON, G., and E. J. ROCHLIN. Über Radiumheferassen. *Arch. Mikrobiol.* **4**: 189-208. 1933.
136. NADSON, G. A., and A. J. ŽOLKEVIČ. Kalium als Antagonist der Röntgenstrahlen und des Radiums. *Biochem. Zeitsch.* **163**: 457-463. 1923.
137. NEIDHART. Beitrag zur Strahlenempfindlichkeit pathogener Hautpilze (*Sporotrichum Beurmanni* und *Trichophyton gypseum*). Inaug. Diss. Zürich. (*Strahlentherapie* **17**: 551. 1924 Abst.)
138. OEHLKERS, F. Phototropische Untersuchungen an *Phycomyces nitens*. *Zeitsch. Bot.* **19**: 1-44. 1927.
139. OSTER, R. H. Results of irradiating *Saccharomyces* with monochromatic ultra-violet light. I. Morphological and respiratory changes. *Jour. Gen. Physiol.* **18**: 71-88. 1934.
140. OSTER, R. H. Results of irradiating *Saccharomyces* with monochromatic ultra-violet light. II. The influence of modifying factors. *Jour. Gen. Physiol.* **18**: 243-250. 1934.
141. OSTER, R. H. Results of irradiating *Saccharomyces* with monochromatic ultra-violet light. III. The absorption of ultra-violet energy by yeast. *Jour. Gen. Physiol.* **18**: 251-254. 1934.
142. OSTER, R. H., and W. A. ARNOLD. Results of irradiating *Saccharomyces* with monochromatic ultra-violet light. IV. Relation of energy to observed inhibitory effects. *Jour. Gen. Physiol.* **18**: 351-355. 1935.
143. OWEN, W. L., and R. L. MOBLEY. The effect of ultra violet rays upon the fermentation efficiency of yeast in the alcoholic fermentation of molasses. *Centralbl. Bakt. 2 Abt.* **88**: 273-286. 1933.
144. PETRI, L. Influenza di substrati nutritivi esposti ai raggi ultravioletti sopra lo sviluppo dei funghi. *Boll. R. Patol. Veg.* **9**: 408-410. 1929.
145. PFEFFER, W. The physiology of plants. Edited and translated by A. J. Ewart. Clarendon; Oxford, 1900.
146. PICHLER, F., and A. WÖBER. Bestrahlungsversuche mit ultraviolettem Licht, Röntgenstrahlen und Radium zur Bekämpfung von Pflanzenkrankheiten. *Centralbl. Bakt. 2. Abt.* **57**: 319-327. 1922.
147. PORTER, C. L., and H. W. BOCKSTÄHLER. Concerning the reaction of certain fungi to various wave lengths of light. *Proc. Indiana Acad. Sci.* **38**: 133-135. 1928.
148. POTTS, G. Zur Physiologie des *Dietyostelium mucoroides*. *Flora* **91**: 281-347. 1902.
149. PRESCOTT, S. C. The effect of radium rays on the colon bacillus, the diphtheria bacillus and yeast. *Science* **20**: 246-248. 1904.
150. PURVIS, J. E., and G. R. WARWICK. The influence of spectral colors on the sporulation of *Saccharomyces*. *Proc. Cambridge Phil. Soc.* **14**: 30-40. 1907.
151. RABINOVITZ-SERENI, D. Il grado di resistenza di alcuni funghi all'azione dei raggi ultra-violetti. *Boll. R. Staz. Patol. Veg.* **12**: 115-144. 1932.

152. RABINOVITZ-SERENI, D. L'azione dei raggi luminosi visibili di differente lunghezza d'onda sull' accrescimento sulla sporificazione e sulla pigmentazione dei funghi in coltura pura. *Boll. R. Staz. Patol. Veg.* **12**: 81-114. 1932.
153. RAHN, O. Influence of light and other rays. In "Microbiology" by C. E. Marshall. P. Blakiston; Philadelphia, 1912. (Cf. pp. 162-165.)
154. RAMSEY, C. B., and A. A. BAILEY. Effects of ultra-violet radiation on sporulation in *Macrosporium* and *Fusarium*. *Botan. Gaz.* **89**: 113-136. 1930.
155. REGEL, E. Ueber die Wirkung des Lichtes auf die Pilze. *Bot. Zeitung* **40**: 29. 1882.
156. REIDEMEISTER, W. Die Bedingungen der Sklerotien- und Sklerotienringbildung von *Botrytis cinerea* auf künstlichen Nährböden. *Annal. Mycol.* **7**: 19-44. 1909.
157. REINHARD, A. W. De l'influence de la lumière sur la multiplication de la levure. *Compt. Rend. Soc. Biol. [Paris]* **89**: 1080-1082. 1923.
158. RIVERA, V. Influenza del trattamento di tubi di emanazione sopra lo sviluppo di alcuni microrganismi vegetali. *Boll. R. Staz. Patol. Veg. Roma* **9**: 241-247. 1929.
159. ROBINSON, W. The condition of growth and development of *Pyronema confluens* Tul. (*P. omphaloides*, (Bull.) Fuckel). *Annals Bot.* **40**: 245-272. 1926.
160. SARDEMANN, E. Ueber die Behandlung der Aktinomykose mit Röntgenstrahlen. *Brunns' Beitr. Klin. Chirur.* **90**: 157-167. 1914.
161. SARTORY, A., R. SARTORY, and J. MEYER. Étude de l'action du radium sur l'*Aspergillus fumigatus* Fresenius in culture sur milieux dissociés et non dissociés. *Compt. Rend. Acad. Sci. [Paris]* **183**: 77-79. 1926.
162. SARTORY, A., R. SARTORY, and J. MEYER. La formation des périthèces chez l'*Aspergillus fumigatus* Fresenius sous l'influence du radium. *Compt. Rend. Acad. Sci. [Paris]* **183**: 1360-1362. 1926.
163. SARTORY, A., R. SARTORY, and J. MEYER. Influence du radium sur la production des zygospores chez *Mucor spinosus* Van Tiegham (*Zygorhynchus spinosus*). *Compt. Rend. Acad. Sci. [Paris]* **186**: 1010-1012. 1928.
164. SCHENCK, E. Die Fruchtkörperbildung bei einigen *Bolbitius*- und *Coprinus*-arten. *Beih. Botan. Centralbl.* **36**: 355-413. 1919.
165. SCHNEIDER, E. Studien über die Röntgenstrahlenwirkung auf Hefe. II. Strahlentherapie **20**: 793-812. 1925.
166. SCHREIBER, H. Strahlenbiologische Untersuchungen besonders im ultravioletten Spektralbezirk an *Saccharomyces turbidans* Hansen. *Strahlentherapie* **49**: 541-595. 1934.
167. SCHULZE, J. Über die Einwirkung der Lichtstrahlen von 280 μ Wellenlänge auf Pflanzenzellen. *Beih. Bot. Centralbl.* **25**: 30-80. 1909.
168. SMITH, E. C. Effects of ultra-violet radiation and temperature on *Fusarium*. I. Lethal action. *Bull. Torrey Botan. Club* **62**: 45-58. 1935.
169. SMITH, E. C. Effects of ultra-violet radiation and temperature on *Fusarium*. II. Stimulation. *Bull. Torrey Botan. Club* **62**: 151-164. 1935.
170. SMITH, E. F., and D. B. SWINGLE. The dry rot of potatoes due to *Fusarium oxysporum*. U. S. Dept. Agric. Bur. Plant Ind. Bull. 55. 1904.
171. SOROKIN, N. Ueber die Wirkung des Lichtes auf die Pilze. *Bot. Jahresber.* **2**: 214. 1874.
172. STAMEROFF, K. Zur Frage über den Einfluss des Lichtes auf das Wachstum der Pflanzen. *Flora* **83**: 135-150. 1897.
173. STEVENS, F. L. Effects of ultra-violet radiation on various fungi. *Botan. Gaz.* **86**: 210-225. 1928.
174. STEVENS, F. L. The sexual stage of fungi induced by ultra-violet rays. *Science* **67**: 514-515. 1928.

175. STEVENS, F. L. Relation of nutrients to perithecial production under ultra-violet irradiation. *Philippine Agric.* **19**: 265-272. 1930.
176. STEVENS, F. L. The effects of ultra-violet irradiation on various Ascomycetes, Sphaeropsidales and Hyphomycetes. *Centralbl. Bakt.* 2 Abt. **82**: 161. 1930.
177. STEVENS, F. L. The response to ultra-violet irradiation shown by various races of *Glomerella cingulata*. *Amer. Jour. Bot.* **17**: 870-881. 1930.
178. STEVENS, F. L. The ascigerous stage of *Colletotrichum lagenarium* induced by ultra-violet irradiation. *Mycologia* **23**: 134-139. 1931.
179. STEVENS, F. L., and J. G. HALL. Variations of fungi due to environment. *Botan. Gaz.* **48**: 1-30. 1909.
180. STOKLASA, J. Bedeutung der Radioaktivität in der Physiologie. *Centralbl. Bakt.* 2. Abt. **40**: 266-280. 1914.
181. STOKLASA, J., and J. PENKAVA. *Biologie des Radiums und Uraniums*. Paul Parey; Berlin, 1932.
182. STROEDE, W. Über den Einfluss von Temperatur und Licht auf die Keimung der Uredosporen von *Puccinia glumarum* f. sp. *tritici* (Schmidt) Erikss. et Henn. *Phytopath. Zeitschr.* **5**: 613-624. 1933.
183. SUGUIRA, K., and S. R. BENEDICT. The action of radium emanation on the vitamins of yeast. *Jour. Biol. Chem.* **39**: 421-433. 1919.
184. SURÁNJI, G., and M. VERMES. Einfluss der Ultravioletten Bestrahlung auf die Atmung von Vogelerythrocyte und Hefezellen. *Orvostudományi Értekezések Gyűjteménye* [Budapest] **30**: 585-590. 1929.
185. TANNER, F. W., and E. RYDER. Action of ultra-violet light on yeast-like fungi II. *Botan. Gaz.* **75**: 309-317. 1923.
186. TEICHLER, G. Über den Einfluss des Antagonismus von Natrium und Calcium auf biologische Wirkungen ultra-violetter Strahlen. *Pfluger's Arch. Physiol.* **227**: 558-570. 1931.
187. TERNETZ, C. Protoplasmaabewegung und Fruchtkörperbildung bei *Ascophanus carneus* Pers. *Jahrb. Wiss. Bot.* **35**: 273-312. 1900.
188. VAN TIEGHEM, P. Action de la lumière sur la végétation du *Penicillium glaucum* dans l'huile. *Bull. Soc. Bot. France* **28**: 186. 1881.
189. VINES, S. H. The influence of light on the growth of unicellular organisms. *Arbeit. Botan. Inst. Würzburg* **2**: 133-147. 1882.
190. VON RECKLINGHAUSEN, M. Purification of water by the ultra-violet rays. *Jour. Amer. Water Works Assoc.* **1**: 565-588. 1914.
191. WARD, H. M. Further experiments on the action of light on *Bacillus anthracis*. *Proc. Roy. Soc. [London]* **53**: 23-44. 1893.
192. WELCH, H. The effect of ultra violet light on molds, toxins and filtrates. *Jour. Prevent. Med.* **4**: 295-330. 1930.
193. WETTSTEIN, R. VON. Untersuchungen über einen neuen pflanzlichen Parasiten des menschlichen Körpers. *Sitzungsber. Math. Naturwiss. Kais. Akad. Wiss.* **91**: 33-58. 1885.
194. WIECHULLA, O. Beiträge zur Kenntnis der Lichtwachstumsreaktion von Phycomyces. *Beitr. Biol. Pfl.* **19**: 371-410. 1932.
195. WYCKOFF, R. W. G. In "Cold Spring Harbor symposia on quantitative biology." Vol. 2. Darwin; New Bedford, 1934. (Cf. p. 248.)
196. WYCKOFF, R. W. G., and B. J. LUYET. The effects of X-rays, cathode and ultra-violet rays on yeast. *Radiology* **17**: 1171-1175. 1931.
197. ZELLER, H. Wirkung von Arzneimitteln und Strahlen auf Hefe. III. Wirkung von Röntgenstrahlen auf Hefe. *Strahlentherapie* **23**: 336-353. 1926.

XXVIII

THE PROBLEM OF MITOGENETIC RAYS

ALEXANDER HOLLAENDER

Laboratory of Plant Physiology, University of Wisconsin, Madison

Introduction. Characteristics of mitogenetic radiation. Earlier experiments of Gurwitsch and others. Yeast as detectors of mitogenetic radiation. Bacteria as detectors of mitogenetic radiation. Biological materials and experimental conditions. Physical methods. Physical properties. Biological senders. Summary. References.

INTRODUCTION

It is now more than ten years since Alexander Gurwitsch (93) first published his discovery of the so-called mitogenetic rays. He reported in 1923 that these rays are given up by some biological materials, for example, the root tips of onions, in certain stages of development; that they pass through quartz, not through glass, that is, they lie in the shorter ultra-violet; and that if they encounter other growing tissues in certain stages of development, they produce effects in these which are readily recognizable in the form of increased growth activity.

Gurwitsch's publications were at first almost entirely ignored. It took several years before the scientific world as a whole took cognizance of his work; and even now many of his critics feel that he has yet to bring proof of the existence of the rays which he claims are causally related to the effects produced. This is in spite of the fact that within a 10-year period more than 400 articles dealing with the phenomenon have appeared.

By far the larger part of these publications has concerned itself with the use of the mitogenetic-ray phenomena in studying biological or chemical problems and only a comparatively few papers have dealt with a critical evaluation of the methods of detecting the rays themselves. It is quite understandable that investigators who accept the Gurwitsch phenomenon should no longer concern themselves with bringing proof of its existence, but it is unfortunate that this fundamental phase of the subject has been left in the main to those who criticize adversely his findings.

It is doubly unfortunate that the problem has attracted some workers who, apparently, see in the problem only an opportunity to deal in the spectacular. In some respects Gurwitsch, himself, is to blame for this. He tends very pronouncedly to accept the work of investigators whose data agree with his theories and to reject almost entirely criticism of a

contradictory nature. The result has been that a large number of scientific workers have become prejudiced against the problem; and the problem has not received the consideration which the work of a man of Gurwitsch's integrity deserves.

A comparative statistical evaluation of all experiments verifying the effect and of those yielding negative results would obviously be unfair because of the general disinclination to publish negative results, in the feeling that these may be due to faulty technique. It has been stated that some investigators reporting negative results have not always followed closely the technique described by Gurwitsch. These workers often believe they have "improved" upon the original technique, but by so doing they may have disregarded various important details. This, also, can be understood easily since Gurwitsch has not published a clear-cut, detailed description of the methods he has found most successful. If the methods are such that each laboratory must largely develop its own procedure, Gurwitsch himself should direct attention to this point, but this he has not done.

The study of the problem of mitogenetic rays is from what has been said above, integrally related to the study of the stimulative action by small quantities of ultra-violet light acting on biological materials. As may be seen from allusions in various papers in this survey, the idea that ultra-violet radiation may stimulate growth activity is a point which is not well established, and in the present state of the literature on the subject it does not seem permissible to be too definite in the matter. This point is discussed here only in so far as it is directly necessary in order to understand the problem of mitogenetic rays. The demonstration of the stimulative action of ultra-violet light does not necessarily presuppose the existence of mitogenetic rays; but the existence of such a stimulative effect is necessary for the understanding of the alleged effects of these rays.

CHARACTERISTICS OF MITOGENETIC RADIATION

Before going into the methods reported as successful in the detection of mitogenetic rays, it may be well to give a few of their characteristics. The majority of the investigators report that the mitogenetic rays are ultra-violet rays of about $\lambda 1900$ to 2500 \AA (48) and that they are of extremely low intensity, about 100 quanta/cm.²/sec. (224). They are reported to be given up by meristematic tissues or cells in a state of active growth, by biological materials in which certain chemical reactions take place, and by many chemical reactions in vitro.

The short ultra-violet region of the spectrum, in which these rays have been included, is a difficult region to utilize experimentally. Most materials will absorb highly these wave-lengths and even quartz can be used only if it is of very high purity. In addition to this, there

is the further complication of the very low intensity of the reported mitogenetic rays—a factor which increases materially the difficulties of the problem. To these two factors we must add the third and most important one—that of the proper handling of the material which gives off the radiation.

Because of the low intensity of the radiation, it is almost outside the range of our most sensitive physical instruments. As a matter of fact, a special instrument has been designed, and with this, in the hands of some investigators, the detection of the rays has been reported. Those who have used this physical detector, a modified Geiger-Müller counter, have announced the detection of the rays from relatively few senders. Thus, it seems that with any investigation in this field one must count, in the main, on a biological detection. That biological detectors may be more sensitive than the most sensitive physical instruments will not surprise the biologist, who realizes that many biological materials are influenced by factors which are as yet imperceptible with our most sensitive physical and chemical tools.

The high sensitivity of the biological indicator makes it a dangerous material with which to work. Merely to keep biological materials in a perfectly uniform condition presents difficulties, but to keep the materials so that they may take the place of and improve upon physical instruments is a problem in itself. Such work requires the utmost experience with the material, carefully devised precautions in the procedure, and a painstaking evaluation of replicated results. In reading numerous reports in this field of work it has not always been apparent that these precautions have been taken; and sometimes only meager evidence has been used; in fact, not infrequently there is evidence that the precautions are inadequate and the data meager, yet these have supported extensive speculations.

EARLY WORK OF GURWITSCH AND OTHERS

It is a well-known fact that many living organisms give up visible light. This has been adequately investigated and good reviews on the subject are available (Harvey, 141, Mangold, 186). It does not seem improbable that ultra-violet radiation should be given up by living materials, although it is somewhat less probable from the physical point of view (Daniels, 61). It was this probability which led Gurwitsch in 1922 (92) to come by way of theoretical considerations to the conclusion that there are, besides obvious chemical effects, certain physical phenomena which have a deciding influence upon cell division, the source of which must lie within the living material. Gurwitsch's (93) search for this source of influence brought him to the study of the influence of certain biological materials in various stages of their development; and for these first experiments he used onion roots. The method of

detecting mitogenetic rays with onion roots is no longer used in his laboratory, but since it is the most fundamental of his experiments and since the most severe criticism has been leveled against it, we shall give here a short review of this work.

In these experiments (for detailed experimental technique see 97, 103) Gurwitsch used roots of the common kitchen onion. The roots selected, about 4 to 12 cm. long, were left attached to the onion bulb, or a part of it. The details of the arrangement are shown in Fig. 1. Special attention was given to the symmetry and straightness of the roots selected. Each of the "detector" roots was in a fairly close fitting glass tube interrupted near the lower end so that the growing region of the root would be exposed when the whole was introduced into a metal tube having a window corresponding to the region of root exposure. The

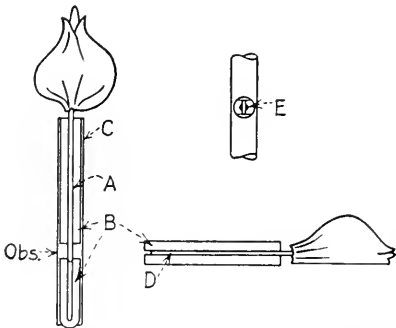

FIG. 1.—Arrangement for Gurwitsch's onion-root experiment. A, detector root; B, capillary glass tube; C, metal tube; D, sending root; E, spot marked for sectioning, as seen in observation microscope. (After Reiter and Gabor, 231.)

“sender” root was also placed in a glass tube, but the tip of the root was not covered, so that when arranged horizontally and opposite the exposure window of the “detector,” a definite root region might be acted upon. In short, he arranged these two roots so that the “projected axis” of the sender struck the detector exactly in the median line. The adjustments were made with a microscope and the entire set-up was kept in position by strong clamps. The roots were kept moist. The time of exposure differed in the individual experiments, but in general he reported that it required from 1 to 3 hr. to get a distinct effect. The detector was allowed to stand after exposure for a certain time, then it was marked and prepared for sectioning. This short length of root, a few millimeters only, in the region selected and exposed, was cut into longitudinal sections and the number of mitotic figures in definite stages to the right and left of the median line was counted. The experiment revealed, according to Gurwitsch, “distinct circumscribed preponderance of mitoses in the center of the ‘induced side’ of the root.” The excess of mitotic figures on the side of the root toward the sender was about 30 to 50 per cent (see Table 1). The results were not substantially different if a quartz plate was placed between sender and detector.

In his original articles (92 to 96, 98, 99) defining the method of the mitogenetic-ray effect, Gurwitsch gives a very detailed discussion of the type of cells counted as well as an estimate of the exactness of the method. But since there are several stages in cell division, the judgment

of the investigator as to which stage he will accept becomes crucial. To make certain that his counts are correct, Gurwitsch (97) reports that he has taken the following precautions: (a) Each slide was counted several times. (b) Each count was made by some one not acquainted with the results obtained by any other counter.

The work on the onion root has been repeated with success by several investigators. Reiter and Gabor (229 to 231), Siebert (262), Loos (175), Paul (206), and others. Reiter and Gabor (231) used a somewhat modified technique, and counted all the mitotic stages, thus obtaining a larger body of material for evaluation. They used cross sections instead of the longitudinal sections of Gurwitsch and they found the results clearly positive, although certain fundamental differences were noted. Loos (175) combined the techniques of Gurwitsch with that of Reiter and Gabor and obtained positive results. Paul (206) in an extensive investigation reported positive results also, but she failed to give her experiments the final test of separating the detector from the sender by a quartz shield.

TABLE 1.—EFFECTS ON ONION-ROOT ACTIVITY OF EXPOSURE TO ONION SOLE AS A BIOLOGICAL SENDER

The Numbers Represent Counts of Mitoses in Different Sections of Roots (Gurwitsch, 97)

A. Sender: freshly prepared pulp of the medullar plate of onions; detector: onion root												
Number of mitoses at												
(a) The "induced" side.....	51	59	90	82	61	60	57	53	72	62	59	37 45
(b) The unexposed side.....	49	63	60	50	51	38	45	43	57	47	38	30 30
(c) Difference.....	2	-4	30	32	10	22	12	10	15	15	21	7 15
B. Sender: pulp of medullar plate heated to 60°C., otherwise as in (A)												
(a) The "induced" side.....	60	66	64	61	63	60	75	81	71	73	73	65 61
(b) The unexposed side.....	61	69	65	62	74	62	60	73	82	66	65	74 69
(c) Difference.....	-1	-3	-1	-1	-13	1	0	2	-1	5	-4	-3 4
C. Sender: pulp kept at room temperature for 24 hr., preceding exposure, otherwise as in (A)												
(a) The "induced" side.....	49	49	49	43	60	51	43	53	41	31	45	51 52
(b) The unexposed side.....	48	53	46	43	58	46	40	49	43	33	44	44 50
(c) Difference.....	1	-4	3	0	2	5	3	4	-2	-2	1	7 2
D. Sender: (B) and (C) materials mixed and used at once, otherwise as in (A)												
(a) The "induced" side.....	43	62	65	75	70	78	79	82	61	58	60	49 52
(b) The unexposed side.....	45	43	48	46	56	61	62	69	57	39	54	42 40
(c) Difference.....	-2	19	17	29	14	17	17	13	4	19	6	7 12

There are two serious objections which have been raised to the onion-root technique: (a) The mitotic figures are naturally not uniform in a cross section of the root, that is, mitotic figures are usually more numerous on one side than on the other, growth being somewhat rhythmically progressive. (b) It is possible to produce changes through pressure, uneven moistening, and other factors scarcely controllable, and these may in themselves induce a considerable preponderance of mitotic figures on one or the other side of the root.

Objections to the work on the two bases mentioned above are reported in a number of papers and extensive experimental evidence is given to sustain these objections. The second point especially has been the center of the attack on the Gurwitsch method. To mention only a few of the investigators who have been unable to repeat Gurwitsch's work on the onion root, I should at least refer to the following: Moissejewa (200 to 202), Rossmann (234), Taylor and Harvey (290), and Wagner (303). Gurwitsch has not used the onion root as detector now for several years but has replaced this method with a yeast technique—a technique which appears at first to be simpler and more easily controlled.

YEAST AS DETECTORS OF MITOGENETIC RADIATION

The yeast method was first described by Baron (12) in Gurwitsch's laboratory. It has been modified and extended by many investigators, although all of these use about the same general type of procedure, varying the details slightly. Nevertheless, no complete description of the technique has been published and the account by Baron (103) in Abderhalden's "Handbuch" is not up to date, since the method has been revised in many particulars.

The reported advantages of the yeast method are that this organism is composed of fairly large cells easy to count, that the method can be standardized, and that pure cultures are readily maintained. To be able to use any yeast technique successfully (that is, in obtaining positive results) one must first have acquired, it is said, some facility in handling this material. Still, each investigator in any other laboratory must work out his own special procedure. There have been times, too, when investigators usually "successful" with the yeast technique have reported unsuccessful experiments. However, such incidents have occurred at times when several or all workers in the particular laboratory were unable to get positive results, and the conclusion was reached that "something had gone wrong with the yeast." It is unfortunate that those working with the yeast cultures in this field have not emphasized the point referred to; the descriptions as published read as if it were possible to repeat the work precisely as in the case of any other standard experiment. A more cautious approach to the problem should at least have been suggested.

For all yeast experiments as conducted by the Gurwitsch school, a standard beer wort is needed. This beer wort must have about "18 balling" sugar. If it has less, the proper amount of sugar must be added, if more, the wort must be diluted. Recently Braunstein and Potozky (33) have published a paper on the use of a synthetic medium, but it has apparently been used only in one laboratory. The wort as it is generally used is sterilized for 10 min. at 2 lb. pressure. After several days the flocky precipitate is filtered off and the wort poured into test tubes.

The yeast used is usually *Saccharomyces ellipsoideus*, a wine type or *Nadsonia* yeast. Slant cultures are prepared with agar containing beer wort of 6 to 10 balling instead of water. These agar slants are considered best after incubation for 20 to 30 days at 25°C. These are the so-called stock cultures. There are, in fact, two entirely different methods of using the yeast as a detector: (a) The agar method. (b) The liquid-yeast method. For the agar or "solid" culture method Petri dishes are prepared with an even layer of fairly solid agar. A finely divided suspension of the stock culture is permitted to settle on the agar surface. The supernatant is then poured off, the Petri dish is kept for 8 to 10 hr. at 16° to 18°C., and the agar layer is cut into small blocks, each with an area of about 1.5 em. and apparently with a uniform layer of yeast. These small blocks are again cut so that one half is used for the detector and the other for the control. It is important that the pieces used as "detector" and "control" should be cut from neighboring sections. In setting up the experiment, the detector is exposed to the sender behind a thin plate of quartz. This quartz must have been previously tested for its transmission of mitogenetic rays, and a test for the transmission of short ultra-violet radiation is not considered sufficient! After exposure the yeast blocks are incubated at 24° to 25°C. for 1.5 hr. Slides are prepared by coating these with a thin layer of egg white. The yeast from the block is distributed in a drop of distilled water and spread over the slide. The slide is then allowed to dry and is fixed by moving it through the flame; the slide is then stained with methylene blue, washed, and dried. All slides are counted with $\frac{1}{12}$ oil immersion, the only consideration being that of determining the number of "mother cells" and of "buds."

The judging of whether one has a "mother" or a "bud" cell presents one of the most important and most difficult steps in the whole agar-yeast procedure. All cells which are attached, definitely round, and less than one-fifth of the size of the cells to which they are attached are counted as buds. If one encounters a doubtful case, the entire field is supposed to be omitted. Special attention must be paid to counting cells from all parts of the slide. At least 100 cells should be counted from each slide, and if the first group of 500 differs very much from the second in percentage of buds, another 500 should be counted. The number of

buds should be about 60 to 80 per thousand for the control, and 80 to 120 for the exposed if the effect is regarded as positive. Since an effect is considered positive only when there is an increase of over 20 per cent (see Table 2), lower percentages are regarded as an indication that further experiments are needed. Gurwitsch (108) indicates in his book that the slides are counted blindly; that is, the person who counts the cells does not know whether he is counting the slide made from the exposed or from the control block. However, from other publications it is not obvious that this rule is followed. It would seem that one should expect those working on the bud-counting method to count all slides blindly, making this the real criterion of the reliability of the work.

TABLE 2.—MUTOINDUCTION OF YEAST, USING TWO AGAR BLOCKS WITH A CULTURE SURFACE OF ABOUT 1 CM.², AT 5 MM. DISTANCE. TIME OF EXPOSURE 15 MIN.; FIXATION ABOUT 1 HR. AFTER EXPOSURE

(From Potozky, 213.) Each horizontal line represents one test

$$\text{Percentage effect} = \frac{\text{induced percentage} - \text{control percentage}}{\text{control percentage}} \times 100$$

Percentage of buds		Percentage effect	Percentage of buds		Percentage effect
Induced	Control		Induced	Control	
15.5	11.5	35	12.0	9.8	23
12.8	9.8	30	11.7	9.7	20
14.5	11.1	30	10.1	8.4	20
13.3	10.7	25	11.7	9.6	22
10.4	8.3	24	10.2	7.0	45
12.7	9.9	29	9.6	7.8	23
11.8	9.7	20			

It is, of course, obvious that this method of counting a large number of yeast cells under the microscope and of continuously judging whether one has a yeast bud or a mother cell is very tiresome and tedious. Those who are working with this method successfully report that they have had very uniform results, much more uniform than those obtained with other methods. In spite of the claim just mentioned, very few publications have appeared recently in which this method was used. It is apparently being replaced by the liquid-yeast method.

The culture medium for the liquid-yeast method is prepared in much the same way as that for the solid-yeast method, omitting the agar. To 10 cc. of the sterile beer wort referred to above 15 drops of a standard yeast suspension are added. This culture is incubated for 16 hr. at 25°C. The yeast suspension should then be in a vigorous stage of fermentation, that is, there should be a constant stream of rising bubbles. The suspension is well mixed before using and the foam is permitted to settle. Two capillary glass chambers, consisting of glass tubes, 1.5 mm. inside

diameter, are filled at the same time from the same pipetteful of suspension. The one tube is exposed to the sender at a distance of 5 to 10 mm. for 5 to 10 min.; the other tube serves as a control. After exposure 0.3 cc. is removed from the detector and 0.3 cc. from the control chamber and each is added to 1 cc. of wort. This is permitted to stand for 4 hr. at 25°C. and then for 12 hr. at 21°C. Next, the yeast is killed with 0.5 cc. of 20 per cent sulfuric acid, after which the preparation is permitted to stand for 10 min. and then diluted with 1 cc. of distilled water.

There are at present several methods for determining the amount of yeast present in the suspension. The simplest way to determine the number of yeast cells is the one described by Potozky and Salkind (213). Here all cells are counted in the Thomas-Zeiss blood-counting chamber. Not less than 10 fields are counted, each with about 130 cells. One precaution is suggested for this method, that is, that the yeast should remain in the incubator for not more than 3 to 4 hr. and that then it should be killed immediately on removal. The method is supposed to give uniform results and to show a positive growth stimulation of about 30 per cent. However, this particular method is not generally used.

A modification of this method has been used occasionally by Baron (14, 241). Here the number of mother cells and the percentage of buds are determined as in the solid-yeast method, but the Zeiss blood-counting chambers are employed. This method gives two sets of data, one on the increase of total yeast and one on the change in percentage of buds. It is employed in certain detailed studies of yeast growth as influenced by mitogenetic rays.

The mycetocrit method described by Brainess is used at present by most investigators who use yeast as the detector for mitogenetic rays. *Mycetocrits* are haematocrits modified so that they are prepared without glass beads. Each mycetocrit has, besides its number, two other markings; one at about 45 mm. from the tip gives the height of the uniform capillary, the other mark near the top indicates the height to which 1 cc. fills the mycetocrit. The mycetocrits are always prepared in pairs, that is, from the same piece of capillary tubing, the capillary mark and the 1 cc. mark coming to the same height in both tubes. It should be possible to use both tubes interchangeably. The tubes are tested before using with mercury and should not differ more than 2 per cent.

The yeast suspension in the test tube is well mixed by a uniform standardized procedure; the material sucked into the mycetocrit, the lower end sealed with cement, and the detector as well as the control mycetocrit centrifuged at the same time for 10 min. at about 3000 r.p.m. In zero experiments, that is, in experiments in which no exposure was made, the heights of the yeast columns should not differ more than 5 per cent. A difference of more than 20 per cent in the exposed over the control is looked upon as a positive effect.

Another method, employed with liquid yeast, involving fewer steps than the mycetocrit, is the nephelometric method. The yeast suspension is diluted 1 to 10 and the difference in scattering and absorption of the light is determined either by an automatic method (Frank, 75) or by means of a Duboseq colorimeter (Klenitzky, 160). In the last method a calibration curve must be made for each set of experiments, that is, the setting of the colorimeter must be tested with the different dilutions of a control experiment and from these figures a calibration curve drawn. From this curve the percentage difference can be determined easily.

Since the yeast method is used in more than 90 per cent of the work of Gurwitsch's school, it may be well to discuss here the merits and disadvantages of the different types of yeast-increase determinations. However, it is claimed that yeast may be used as sender or detector only in the presence of visible light (213). A criticism of this procedure is made later, in view of the factor of stray light.

The yeast-bud-counting method from agar surfaces seems to be the least "objective." Taking samples from the Petri dish before exposure and counting buds and mother cells by the thousands are tedious tasks and require great patience, since there are many possibilities for errors. The liquid-yeast method seems to the reviewer the more objective. The use of the blood-counting chamber is well established; but if it is not standardized it may be a large source of error. For the reason just stated, the mycetocrit technique would appear to add to the objectivity of the liquid method; since the mycetocrit gives quick results and thus permits the handling of a large number of experiments. The nephelometric method, in the reviewer's experience, is not sufficiently sensitive for the accurate determination of an increase of yeast. At least, it seems that the use of the usual type of colorimeter is not so exact as the work demands.

In all this work it is presupposed that the yeast growth in two separate test tubes is so uniform that the tubes could be used interchangeably when not exposed. The presence of a mitogenetic effect is determined by either an increase or decrease over the control. Many investigators doubt that conditions can be maintained so perfectly uniform that the growth of yeast will not be somewhat influenced thereby. Since increase and decrease are accepted as effects, it would seem necessary that all experiments should be run in duplicate, at least, and that all controls check each other. That this is being done is not indicated in the publications. It is reported by Gurwitsch (108) that each experiment must be repeated at least eight times before it is accepted as definite. It is, however, not unusual for a very important conclusion to be made from two experiments performed at different times (Klenitzky, 158).

It is unfortunate also that no statistical evaluations of the yeast method have been published in which the fundamental data have been critically discussed. Experiments performed with yeast run into many thousands and it is difficult to understand why the evaluation of the probable error of the fundamental procedures has been entirely neglected.

Many of the foregoing points have been brought out in articles which have come from entirely different laboratories. Attention should be called here to the articles by Schreiber (254), Rossmann (235), and Richards and Taylor (233). None of these authors was able to repeat Gurwitsch's work. In a paper by Rajewsky (226) a statistical evaluation is made and the results given are not the most encouraging.

Baron (14) believes he has established a so-called "makro-effect." That is, by continuous exposure of a hanging-drop culture of yeast he reports effects which are visible to the eye. As yet no other investigator reports success with this method. Gesenius (84), after exposing yeast suspensions to a mitogenetic-ray sender, tested their fermentation rates with a Warburg apparatus. He reports that he obtained consistently a decreased fermentation from the exposed yeast. Gurwitsch (105) explains that the "decrease" effect is caused by too long an exposure to the mitogenetic-ray sender or to an excessive production of secondary radiation.

BACTERIA AS DETECTORS OF MITOGENETIC RADIATION

Besides yeast, bacteria have been used extensively as detectors of mitogenetic rays. Early in the development of this field of work the use of bacteria was reported by Magrou and Magrou (177, 181), Sewertzowa (258), and Baron (13), later by Wolff and Ras (306 to 308), Acs (1, 2), and Ferguson and Rahn (71). This method has been developed especially by Wolff and Ras to such a degree that they report what are apparently uniform results.

Wolff and Ras (309) give the following as worthy of consideration, or conditions to be complied with, if correct results are to be expected: A type of bacteria standardized for the purpose (*Staphylococcus aureus* is now used almost exclusively by Wolff and Ras); standard bacterial concentrations at the beginning of the experiments (about 400,000 to 600,000 per cc.); age of culture from which the transfer is made; temperature at which the bacteria are maintained. Bacteria, like yeasts, can be used effectively as detectors only at the time just preceding their maximum growth rate, that is, they should be used during the late "lag" phase. The sample of bacterial suspensions, 2.5 mm.³, is removed to a culture medium; after exposure this is incubated and the number of bacteria determined from the colonies in agar-plate cultures, or,

after exposure, the bacteria are plated in Wright cells. The method of Wolff and Ras appears at first sight very simple, but if we consider that the method involves the removal and handling of only 2.5 mm.³ of suspension, it would seem, at least, that extensive experience would be necessary to handle these small quantities, so that each 2.5 mm.³ should contain the standard number of bacteria. The difficulty of handling such small quantities of material is probably the reason why this method has not become more popular.

BIOLOGICAL MATERIALS AND EXPERIMENTAL CONDITIONS

Besides yeast, bacteria, and onion-root tips, a number of other detectors have been used. There is a group of articles (77, 81, 182 to 184) describing the use of sea-urchin eggs as indicators of the production of mitogenetic rays. Apparently good effects have been obtained, but since sea-urchin eggs are not available the year round and since the laboratories where sea-urchin eggs can be had are few, this method has not been used extensively. Positive results have also been reported with fungus spores (248), speed of enzymatic reactions (190), and the increase in number of mitotic figures in certain tissues of the eye of rabbits (exposed contrasted with nonexposed) (117).

In 1930 Stempell published several articles (275 to 286) on the detection of mitogenetic rays by their effect on the formation of Liesegang rings in gelatin, etc. He obtained the effect through cellophane. That the action on the rings was mainly a chemical one, caused by the vapors given up by the supposed mitogenetic-ray sender was shown by Tokin (291), Siebert (265), and others. Later Stempell and Romberg (279) reported this fact themselves. However, in an extensive publication the same authors (283) give some experiments as a result of which they believe that they have obtained some effects through quartz. The use of Liesegang rings as a detector has not since been reported.

In all the work with biological detectors certain very definite features should be emphasized. All the biological materials, especially the microorganisms, should be used as detectors when not in a state of most rapid multiplication. It has been indicated previously that the yeast should be in the "lag" stage (cf. Tuthill and Rahn, 292). The view held is that when in a rapid state of development no additional growth can be expected with the food materials available. Moreover, all conditions should be as standardized as possible. The dilution of the organism in suspension and the type of nutrient solution should be adjusted to the special strain one uses.

Certain questions are suggested. Are the detectors quantitative indicators? Do they show great response to increased intensity? In both cases the answer is in the negative. They will respond within certain limits, that is, they may respond quicker to a so-called intense

sender; but this point has not been worked out in detail. This brings us to the time of exposure. The time period must be determined for each organism, set-up, sender, etc., separately. The time apparently is very important, since an exposure which is too long may give negative effects. Apparently the detectors have several maxima of response (289). For this reason it is advisable to repeat each experiment several times at different lengths of exposure since even the same detector does not always respond to the same time of exposure. A detailed discussion of the variation in response is given by Salkind (241). However, the point of "mitogenetic depression" is not clear. Gurwitsch (108) in his book (p. 13) reports that the mitogenetic effect with the same detector should always give the same effect, that is, always an increase or always a decrease—all positive or all negative effects. Workers in this field report, especially with the liquid-yeast technique, that plus and minus effects can appear side by side (Karpas, 174). In the work on bacteria positive results reported are always plus effects. Salkind (241) distinguishes different types of mitogenetic depression, where he counted both the change in percentage of buds and the increase in the total number of yeast cells. He calls the increase in the amount of budding "stimulation"; an increase in budding and in the number of mother cells is also "stimulation"; a decrease in budding and an increase in the total number of cells is "stimulated depression"; while a decrease in budding and a decrease in total cells is "true depression."

Gurwitsch reports that it is easier to modify the time of exposure, and to diminish the total time of exposure by interrupting the exposure systematically by employing a rotating disk which has several cut-outs. It is thought that with a number of interrupted exposures the time element can be more conveniently arranged. Investigators working on detectors other than yeast have not reported very great success with interrupted exposures, and in general the work done is insufficient to justify detailed discussion at this time.

It is known that chemical vapors may have a pronounced influence on biological materials, either depressing or stimulating effects, and all precautions against any possible influence of this type should be taken. Exposures should be made only through quartz with high transmission for the short ultra-violet radiation. Moreover, a piece of quartz between sender and detector is not sufficient; if possible, the detector should be closed vapor-tight from the sender in a container with a quartz window (see Fig. 2). Have these precautions always been taken? It would perhaps be unfair to generalize.

But there are articles—too many to be ignored—in which mention is made of the use of quartz between sender and detector in at least one trial experiment, the remainder of the work being done wholly without this precaution. No difference in effects was reported; so it is

unfair to generalize from these partial tests, especially when such work as has been done with the spectrograph would apparently exclude any possible chemical effects. Those who report favorably on mitogenetic rays should evaluate critically not only the papers reporting "no effects" but also papers which report "positive effects." In this way good service would be rendered by the elimination of much material that adds only to the confusion of this very difficult problem.

It is known that the media (agar, etc.) in which yeast and bacteria grow will absorb highly below $\lambda 3000 \text{ \AA}$ and that it will not transmit

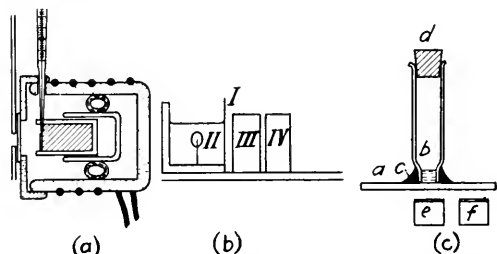

FIG. 2.—Three arrangements for gastight isolation of mitogenetic sources. (a) Incubator chamber with quartz window (after Baron); (b) chamber with quartz window: I, quartz plate; II, tumor; III, detector; IV, control; (c) chamber (after Blacher): a, quartz plate; b, radiating material; c, cement; d, stopper; e, detector; f, control. (Gurwitsch, 108.)

1 per cent of light below $\lambda 2500 \text{ \AA}$, the presupposed upper wave-length limit of mitogenetic rays. How is it possible that an effect of the order of magnitude of 100 quanta/cm.²/sec. can be recognized in 1 to 2 cm. depth in the detector suspension, for example? Gurwitsch (106, 122, 127) explains this by the so-called "secondary radiation." In fact, an understanding of mitogenetic

radiation is not now possible without an understanding of what is here meant by secondary radiation. There are several explanations suggested for this phenomenon, such as the following: (a) the incoming radiation may activate an enzyme which will increase this small stimulus and will finally produce a recognizable effect; (b) a chain reaction may be set up since often only relatively small amounts of energy are necessary to get a chain reaction started. This might very well take place in the form of a modified explosion. Wolff and Ras (309) have investigated secondary radiation more in detail. They placed between the sender and detector a tube with quartz windows 10 cm. long. This tube contained such as (a) dilute bacterial suspensions, (b) suspensions from which the bacteria had been removed by centrifugation, and (c) suspensions of nucleic acid. The radiation leaving these intervening materials is, if the suspensions are diluted enough, more intense than the radiation entering them, although the materials cannot be used as secondary senders indefinitely. However, they recover if not used for a certain period of time. In spite of these explanations it is difficult to accept all these findings without question. If they are correct, an entirely new field of investigation is opened. But before accepting these findings, very much more quantitative work must be done by way of confirmation and extension of present

data. It would be important, particularly, to see confirmatory work from different laboratories.

PHYSICAL METHODS

It is often thought that a phenomenon exists only if it is possible to detect it with some purely physical tool. But biologists have often discovered and proved the existence of a new phenomenon long before physical tools were developed for its detection. Many examples from the history of science could be brought forward to demonstrate this point, and it still remains true that even if physical detectors do fail, one may be able to rely on biological methods, that is, if they are handled properly, and if sufficient statistical material is available to evaluate the results beyond doubt. Of course, it is highly important to have a simple physical method of measuring mitogenetic radiation, assuming its demonstration, and for this reason many attempts have been made to develop the necessary apparatus—some allegedly successful.

Photographing the radiation given up by the sender would suggest itself at once. Most of those who have tried this have not had success. However, some investigators report positive results. The photographic plate is unpromising as a detector of such weak radiation for several reasons: the sensitivity of the plate decreases rapidly below $\lambda 2500 \text{ \AA}$, and even specially sensitized plates and Schumann plates are at best less sensitive than our fastest plates in the visible. For very small quantities of light the reciprocity law apparently does not hold, that is, it is not possible to irradiate a plate for a very long time with extremely small quantities of light and obtain the same result as would be obtained by giving the total energy at one time. The amount of energy necessary to obtain a recognizable impression on the photographic plate is very much higher (about $10^{-3} \text{ erg/cm.}^2/\text{sec.}$) than is supposed to be at the disposal of the investigator working with mitogenetic radiation ($10^{-9} \text{ erg/cm.}^2/\text{sec.}$).

Reiter and Gabor (231) report a few experiments with the photographic plate which seem to be successful, but they themselves are not much convinced of their results. A number of other investigators report positive effects with the photographic plate: Brunetti and Maxia (37), Čech (47), Protti (219), Copisarow (55, 56). In all of these cases the work is not explainable on this basis and it may be assumed that these results must have been influenced either by chemical effects or by some other factors which had nothing to do with mitogenetic rays.

In 1930 Rajewsky (223) published the details of the construction of an apparatus with which he reported he was able to detect as little as $10^{-12} \text{ erg/cm.}^2/\text{sec.}$ Shortly afterward (224) he reported that he had obtained with this apparatus objective records of the existence of mitogenetic rays. He used a modified Geiger-Müller counter, an apparatus

which is being used for the measuring of weak corpuscular radiation, alpha and beta rays, and very extensively in work with cosmic radiation. The counter (Fig. 3) consists of a metal tube which serves as cathode; through this tube a special wire is stretched which is held in position by means of rubber stoppers. This wire is connected with a high resistance through an electrometer with the ground. The cathode is connected to a set of batteries (about 1000 volts) and grounded through a resistance. The tube is filled either with air or some other inert gas at reduced pressure. The setup is balanced so that only ionization of the gas in the tube will permit a discharge to take place. Radioactive material in the laboratory, or cosmic radiation will cause a certain number of discharges

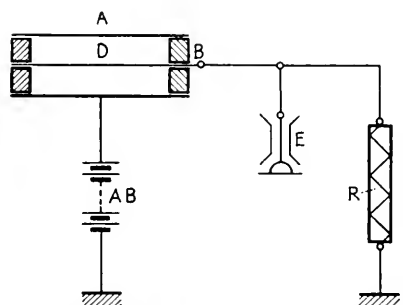

FIG. 3.—Diagram of Geiger-Müller counter. A, counting chamber; B, insulating stopper; AB, batteries; E, electrometer; R, resistance; D, anode wire. (After Rajewsky, 224.)

to take place. Rajewsky covered the wall with a photoactive material, cadmium, since it is photoactive in the short ultra-violet, and equipped the tube with a quartz window. The cell when protected with a heavy iron jacket gave about 30 discharges per min. as recorded by visual observation or by means of a mechanical recording device. When he placed some of the mitogenetic senders before the window of the counter, the discharges increased about 30 per cent.

He took observations with the sender for 10 to 12 min., and then for 10 to 12 min. without the sender, or with a sheet of glass placed between sender and cell. Repeating this for several hours he obtained results that are very interesting. A typical set of records is given in Table 3.

Rajewsky was not able to obtain any effect from yeast, the most generally used of all the senders. Up to the present Rajewsky has not published any statistical evaluation of his results. The work of Rajewsky was quickly followed by that of Frank and Rodionow (79); the latter working with the same type of setup were able to verify the work of Rajewsky. Frank's results were very striking. However, the work could not be repeated at will, since the cathode quickly declined in its ability to emit photoelectrons, and for every experiment they were forced to prepare a new counter. Thus the work was very tedious and was robbed somewhat of its reliability. Frank and Rodionow found that the emission was very much increased by the presence of visible light at the sender, but they were careful to keep the visible light from the counter by means of a spectrograph and used only the ultra-violet part of the spectrum.

Siebert and Seffert (269) report in a short notice that they have been able to construct a set of two modified counters which have exactly the

TABLE 3.—RESULTS WITH THE MODIFIED GEIGER COUNTER
(After Rajewsky, 224)

1. Sender: onion root. Subjective counting with electrometer and loud-speaker. Counting time, 5 min.

Registrations per minute		Percentage increase
Without root	With root	
42 ± 1	51 ± 7	21

2. Sender: onion plate pulp. Automatic registration. Counting time, 10 min.

Registrations per minute		Percentage increase
Without pulp	With pulp	
42.2 ± 1.2	50 ± 1.5	21
39.8 ± 0.3	49.3 ± 2.2	24

3. Sender: mouse carcinoma. Automatic registration. Counting time, 10 min.

Registrations per minute		Percentage increase
Without carcinoma	With carcinoma	
23.4 ± 0.6	30.3 ± 0.5	29.5

4. Sender: onion sole as in Gurwitsch's fundamental experiment. Automatic registration. Counting time, 9 min.

Registrations per minute		Percentage increase	Registrations per minute	
Without root	With root and bulb		With root, through glass	With root segment
33.3 ± 1.4	36.7 ± 0.5	17	30.7 ± 0.1	30.9

same sensitivity. They placed the sender before one cell and the difference in the number of discharges between the two tubes indicates the intensity of the radiation given up by the sender.

In a lecture on the problem of mitogenetic rays, Gerlach (83) reported the successful use of these modified Geiger counters in the detection of mitogenetic radiation given up by blood. Unfortunately no details concerning this work have as yet been published. Petri (241, 242) published a simplified setup, the cell of which is so constructed that the electrometer was combined with a photoelectric cell. The leaves of the electrometer were charged and the speed of discharge was tested with and without sender. The sensitivity reported for this instrument is not

great enough to detect the intensity of radiation said to characterize the mitogenetic sender. In spite of this, positive results are reported.

Schreiber and Friedrich (252) published at about the same time as Rajewsky an apparently thorough investigation with a modified counter, the sensitivity of which is reported to be not so great as that of the one of Rajewsky. They report entirely negative results.

Seyfert (261), working in Geiger's laboratory, constructed the Geiger counter as modified by Rajewsky, and he reports a sensitivity of 10 quanta/cm.²/sec.; furthermore, in what appears to be a thorough investigation he obtained entirely negative results.

Lorentz (176) in this country reports work on the same type of counter with a reported sensitivity of 10 quanta/cm.²/sec. A number of materials which had been reported to be senders gave no effects on his counter. Grey and Ouellet (90) using a high sensitivity counter report entirely negative results with sea-urchin eggs as sender, in spite of the fact that these have been reported to be unusually good emitters of mitogenetic rays.

It is very difficult to decide upon the question of the use of the modified Geiger counter for the detection of mitogenetic rays, since both positive and negative results have come from laboratories with well-established reputations for good work. Further work must be awaited. Especially is it important that a thorough statistical evaluation be made of the work alleging positive results. Certainly it is necessary to find out whether all precautions against temperature changes, spurious electrical effects, adsorption phenomena, etc., have been taken. If we are to work with an instrument of a sensitivity of 10 quanta/cm.²/sec., customary precautions are far from being sufficient. It is not clear to the reviewer that the sensitivity of these counters, which have been determined by classical methods—methods which until now have been used only when millions of quanta were available—will apply also when 10 to 100 quanta/cm.²/sec. are at our disposal. A more detailed discussion of this point will be given in another article.

If we ignore the work where the results have been negative and accept the modified Geiger counter as an established instrument, we are apt to wonder why, during the four years that this instrument has been reported to be used successfully, no actual new work with the counter as detector has appeared. Only such work as has been reported to be successful with the biological detectors has been checked with the Geiger counter and this only in a relatively small number of cases. One of the senders most frequently used—yeast—has never recorded radiation on the counter.

PHYSICAL PROPERTIES

The physical properties of mitogenetic rays are said to be, so far as studied, the same as those of any other ultra-violet radiation. The light

is reflected, refracted, etc. These different features of this radiation are especially well brought out by the work of Reiter and Gabor (231). But it is somewhat difficult to understand these striking results if we

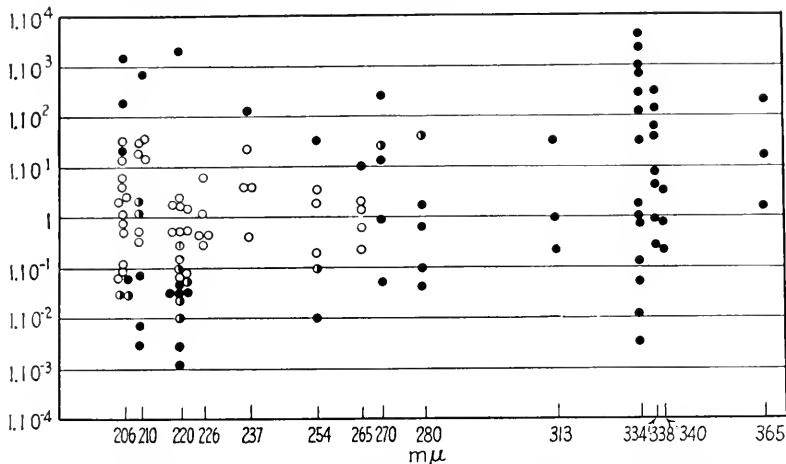

FIG. 4.—Graphic demonstration of the results using yeast as detector and monochromatic light as sender. Outlined circles designate positive effects; half-blocked circles, doubtful cases; blocked circles, zero effects. The ordinates express the intensities in arbitrary units; the abscissas, wave-lengths in millimicrons. (After Chariton, Frank, and Kannegiesser, 48.)

accept the statement of Gurwitsch (111) that the effect is not localized on the detector and that it spreads several millimeters and then fades slowly. The wave-length determined by Reiter and Gabor is around $\lambda 3400 \text{ \AA}$, a much higher value than the estimates which appear in the majority of published papers, where the wave-length is represented as below 2500 \AA . An especially extended investigation was made by Chariton, Frank, and Kannegiesser (48) (Fig. 4). It is not possible to bring Reiter and Gabor's estimate of $\lambda 3400 \text{ \AA}$ into any direct relation with the $\lambda 1950$ to 2500 \AA of the Gurwitsch school. It may well be that Reiter and Gabor had an entirely different effect.

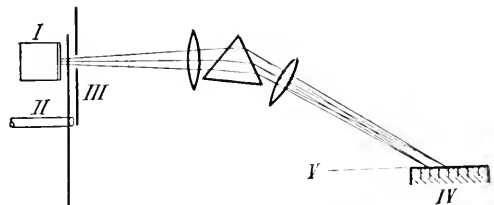

FIG. 5.—Arrangement for spectral analysis of mitogenic radiation. I, source of radiation, in chamber with quartz window; II, rotating disk; III, entrance slit of spectrograph; IV, agar blocks with surface layer of yeast—blocks separated from each other by celluloid strips. (After Gurwitsch, 108.) Newer experimental arrangements have a very well adjusted exit slit.

Does artificial radiation of the proper wave-length produce the same effect? Frank (76), Reiter and Gabor (232), and Ruyssen (238) report that this seems to be a fact. However, the energy necessary to produce these effects from an artificial light source is of an entirely different order

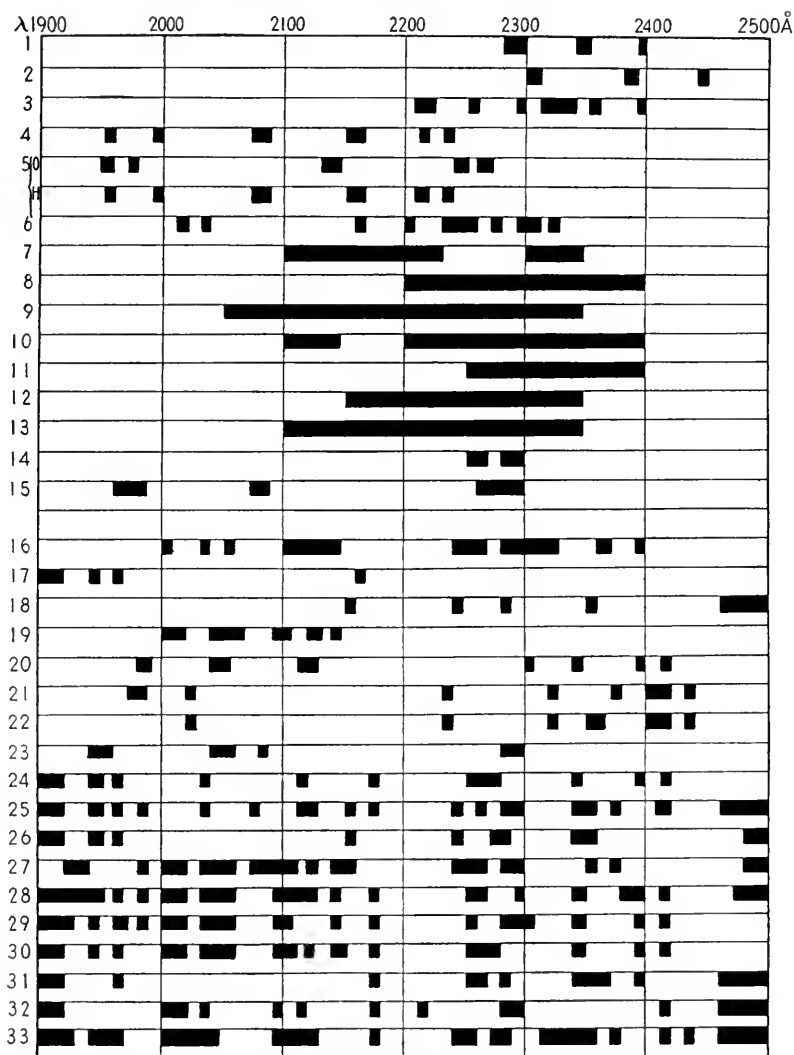

FIG. 6.—Mitogenetic spectra. 1. Reduction of Cu^{++} to Cu (electrochem.) (33). 2. Reduction of Zn^{++} to Zn (electrochem.) (33). 3. Reduction of Hg^{++} to Hg (electrochem.) (33). 4. Reaction, $\text{HCl} + \text{Zn}$, $\text{HCl} + \text{Cu}$, $\text{HCl} + \text{Mg}$, $\text{HCl} + \text{Al}$ (33). 5a. Reduction of $\text{O}_2 \rightarrow \text{O}^{\cdot-}$ (OH^{\cdot}) (electrochem.) (33). 5b. $\text{H} \rightarrow \text{H}_2$ (electrochem.) (33). 6. Redox reaction, $\text{Fe}_2(\text{SO}_4)_3 + \text{FeSO}_4$ (electrochem.) (33). 7. Reaction, $\text{K}_2\text{Cr}_2\text{O}_7 + \text{FeSO}_4$ (212). 8. Reaction, $\text{FeCl}_3 + \text{NH}_2\text{OH} \cdot \text{HCl}$ (212). 9. Reaction, $\text{KMnO}_4 + \text{H}_2\text{O}_2$ (212). 10. Reaction, $\text{HgCl}_2 + \text{SnCl}_2$ (212). 11. Reaction, $\text{HNO}_3 + \text{FeSO}_4 (+\text{H}_2\text{SO}_4)$ (212). 12. Reaction, $\text{KClO}_3 + \text{Zn} + \text{NaOH}$ (212). 13. Reaction, $\text{Pt} + \text{H}_2\text{O}_2$ (212). 14. Reaction, $\text{KOH} + \text{pyrogallol}$ (120). 15. Reaction, $\text{NaOH} + \text{HCl}$ (212). 16. Photosynthesis (212). 17. Glycolysis, spectrum from blood radiation (also obtained from corneal epithelium) (152). 18. Phosphatase (action on phosphates) (126). 19. Breaking down of creatin phosphatase (34). 20. Protein digestion (18). 21. Reaction, amylase with maltose (160). 22. Reaction, cane sugar with yeast saccharase (160). 23. Reaction, urea with urease (160). 24. From resting nerve (151). 25. From nerve pulp (151). 26. Nerve mechanically stimulated (at point of stimulation) (151). 27. Nerve electrically stimulated between electrodes (151). 28. Nerve, traumatic stimulus about 20 mm. from the trauma (151). 29. Nerve, electric stimulus 20 mm. from electrodes (151). 30. Nerve, conduction of stimulus (20 min.) (111). 31. Small brain (111). 32. Large brain (111). 33. Optic nerve (111). (Collected and supplied by Gurwitsch.)

of magnitude from that which is thought to be given off by the biological sender. Against these reports stand the publications of Schreiber (251) and others who have not been able to obtain stimulation by artificial light. Since the general field of stimulation as such is still in a very confused state, it may be that a new approach to the problem of stimulation will be made possible if the mitogenetic-ray work should prove correct.

The detector not only responds to certain wave-lengths, but each biological sender is reported to have its own definite spectrum, that is, the radiation given up by each sender has very definite wave-lengths. The sender is placed about 3 to 5 cm. in front of the slit of a medium quartz spectrograph (Fig. 5). The place of the photographic plate is taken either by small yeast-agar blocks, or by a set of tubes of liquid yeast or bacterial suspension. The blocks or tubes are so arranged that each will be exposed to a definite band of the spectrum. It has been reported that it is possible to separate in a medium-size quartz spectrograph bands as small as 10 Å units. The materials were exposed for about 2 min., the detectors treated in the standard way, and the percentage increase determined as usual. A table of typical results (see Table 4) is given. Typical sets of spectra obtained by this method are given in Fig. 6.

Before going into the biological phenomenon or reaction of the senders themselves, a few words are in place concerning the spectral technique. In spectrographic work certain precautions must be taken, such as the adjusting of the spectrograph, optical adjustments, and others. It is not possible to get uniform results without adjusting the slit carefully; in fact, in order to obtain 10 Å bands without overlapping, a fairly narrow slit must be used. It is not obvious that sufficient precautions have been taken to insure a good optical setup with the work reported from laboratories working on this problem. This brings us back again to the

TABLE 4.—SPECTRAL TABLE OF EMISSION FROM RABBIT'S EYE

Using yeast instead of photographic plate as detector, with two time intervals and expressing results as percentage effects, plus or minus in comparison with controls (second and third columns) (*Gurwitsch*, 108)

Spectral region in Å units	Time of exposure	
	5 min.	1 min.
1900-1940	-24	+23
1940-2000	-17	+58
2000-2080	- 3	0
2080-2160	7	- 2 6
2160-2260	-20	+33
2260-2390	4	0

intensity of the mitogenetic rays. Rajewsky (224) reports their intensity, as obtained from tests in the modified Geiger counter, as about 10 to 100 quanta/cm.²/sec. Frank and Rodinow (79) report 100 to 1000 quanta/cm.²/sec. It seems that the intensity might be regarded as closer to Rajewsky's calculation, and in fact several investigators claim that Rajewsky's calculations are too high. If, however, we accept 100 quanta/cm.²/sec. as a possible figure and use a slit of 0.4 mm. width and a time of exposure of 2 min., we have a total of 480 quanta. And if we suppose that 50 per cent of the radiation is lost in the spectrograph, we have 240 quanta left. We divide this into 30 bands (nerve radiation) and we have for each band 8 quanta. Each detector tube covers about one-third of the exit slit. Each liquid detector culture would then get a total of 3 quanta in 2 min. This total of 3 quanta is supposed to be enough to cause 0.5 cc. of yeast suspension to show a growth increase of 20 per cent. Of course, it may be possible that the energy estimations are too low and it is also possible that living materials respond to energy for which we have as yet no equivalent in physics.

BIOLOGICAL SENDERS

As mentioned in the introduction, there are several hundred publications on the application of the mitogenetic-ray method to the study of biological problems. Problems offering real possibilities have been investigated; on the other hand, many problems which have been attacked are of the utmost complexity, as for instance, the work on nerve physiology, the work on blood, and on cancer. An idea of the type of work which has been attempted, and for which success is not infrequently claimed, may be obtained from a glance at the titles in the literature list; the reviewer must leave to specialists in these several fields as to whether, from this work, we should indulge our hopes or our sorrows.

We shall attempt, as far as it seems feasible at present, to bring all this work under a common schema as it were. In doing this we shall for the time being accept all the results as definite, and all doubts about the reliability of the technique or about the experimental procedure will be ignored while attempting to review it as a proponent might.

In most of the newer work published from the Gurwitseh school, a spectral interpretation of the source is attempted. In other words, the mitogenetic-emission spectrum is determined and the spectra are compared with the established spectra of fundamental reactions. There are three fundamental reactions which give typical spectra: oxidation, proteolysis, and glycolysis. It is not necessary that in a biological reaction a complete fundamental spectrum appear; it sometimes happens that only the major band will be recognizable. The spectra given in Fig. 6 are partly obtained by biological reactions and partly by purely chemical reactions, as the spectra given are typical. One must not rely

too much on the correctness of the wave-length of these spectra since, as mentioned before, the physical technique was such that a displacement of an entire spectrum for as much as 100 Å units does not seem at all impossible.

The greater part of the work on the application of the mitogenetic-ray technique has been done with animal materials and only relatively little with plant material, with the exception, of course, that the latter have been used extensively as detectors—in growth effects. Onion sole was one of the first senders used in mitogenetic work. This material consists of a pulp made by grinding the medullary plate of the onion bulb.

Following the chemical experiments of Du Bois and of Harvey (141) on the two enzymes, luciferine and luciferase,—Gurwitsch (97) reports he was able to separate two substances from a pulp made by grinding up the medullary plate of the common onion (see Table 1). He calls these two substances mitotin and mitotase and says they behave like luciferine and luciferase. This reaction gives a typical oxidation spectrum. The radiation given up at the root tip apparently does not have its origin there but rather in the medullary plate, and it is transmitted through secondary radiation to the root tip. That distance is often 10 to 15 cm. The spectrum of the root-tip radiation is of glycolytic origin. Thus the secondary radiation does not necessarily have the spectrum of the primary radiation in it. A cut segment of root which otherwise would not radiate may also be brought to radiation by an oxidation reaction, as explained in Fig. 7. Besides onion material, damaged leptome bundles of potatoes (155), the cotyledons of *Helianthus*, a mash of yellow-beet tissue (80, 102), and the pulp of *Sedum latifolium* (108) are serviceable, if kept over night at low temperature, but not the fresh material. For negative results on the last-mentioned materials see Haberlandt (139).

Bacteria (1, 2, 8, 13) and yeast (12, 14, 38, 292) during the "log" stage of their development are good senders. Yeast can be used as detector or sender only in the presence of some visible light (213). Since these organisms can be senders as well as detectors, we have in each suspension what has been called "mito-induction." That these organisms in dense suspensions grow faster than in very dilute suspensions is one of the features pointing toward the radiation explanation. However, workers in the field have not as yet explained how this concept fits in

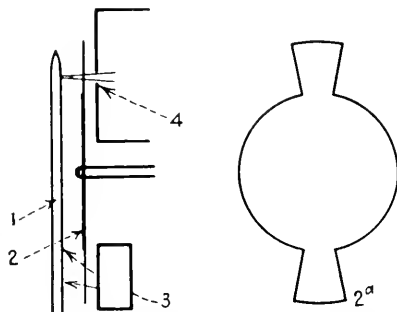

FIG. 7—Arrangement for spectral analysis of secondary radiation from a segment of onion root: 1, segment of onion root; 2, rotating disk with cutouts; 3, yeast agar block (sender); 4, entrance slit of quartz spectrograph. (After Gurwitsch, 108.)

with the idea of secondary radiation (see page 932). If isolated organisms in bouillon, for instance, excite secondary radiation in the medium, and this secondary radiation is more intense than the primary radiation, we should expect to have here very quick growth, more so than in dense suspensions.

Very much work has been reported on invertebrates, since invertebrate material lends itself very well to experimental investigation. The material has been used as sender as well as detector. To judge from the illustrations giving experimental arrangements, it appears to be very difficult, to say the least, to get uniform results. To many investigators working in this field it seems that many experimental difficulties which usually handicap the work of other investigators have apparently been ignored by those reporting success in mitogenetic work. Magrou, Magrou, and Chougroun (183) reported successful work, but later this was attacked by Chougroun (49, 50). Apparently insufficient precautions had been taken against chemical or spurious electrical effects.

Sea-urchin eggs are very good senders for a certain time after fertilization (65, 77), that is, the time for which Warburg has reported a very large increase of oxygen consumption. Gurwitsch (108) believes that here, too, we have a mitotin-mitotase process which is the source of the radiation.

Axolotl larvae up to 1 cm. are good radiators. Apparently here the brain is the source of the radiations (Anikin, 3). A pulp made of brain tissue will radiate while a pulp from the rest of the body will not. Developing *Drosophila* eggs are good senders (Wolff and Ras, 310).

In a large number of papers, Blacher and his coworkers (21 to 26, 35, 147, 173) report the resorption process as a source of mitogenetic radiation. Gurwitsch (108) states that there are three proofs which Blacher has brought for his contention: (a) the appearance of mitogenetic radiation during the metamorphosis of the insect egg (*Drosophila*); (b) the relation between natural (induced) and forced metamorphosis of amphibia and mitogenetic radiation; and (c) the relation between wound products, wound healing, and mitogenetic radiation. Embryonal stages of higher animals, chicken embryos, especially, have been investigated. Brain tissue of embryos will not radiate (Kisliak-Statkewitsch, 155, 108) but the yellow of the egg incubated for 2 to 3 days makes a good sender.

Positive success with the effect of mitogenetic rays on tissue cultures has been reported by Chrustschoff (52) and others (214). However, against their work stands a number of experiments (312) where negative results are reported.

A large number of authors (31, 85, 89, 114, 169, 175, 214, 216, 245) report on the mitogenetic radiation of the blood and of organs which depend on blood radiation. Blood from many normal or healthy animals is reported to radiate in vivo and in vitro, if handled properly. Circulat-

ing blood has been tested by exposing the abdominal vein of the female frog covered only with an extremely thin skin. The vein was then exposed to the onion or yeast detector (89). Fresh blood may be tested by mixing it with a 4 per cent solution of $MgSO_4$, diluted by an equal quantity of water, and the exposure made in a capillary chamber. Or the blood may be taken up with a piece of filter paper, dried, and ground up with water to a fine pulp (154). Fresh blood must be used as sender within 10 min. after it is taken, if used with $MgSO_4$; but it is good for several hours if the filter-paper method is used. During asphyxia with CO or poisoning with HCN, blood will not radiate nor will the blood of starving animals radiate. Blood serum can be brought to radiate by the addition of H_2O_2 or oxyhemoglobin.

The blood of man and animals with malignant tumors and serious blood diseases such as poisoning, complicated sepsis, pernicious anemia, and leucemia will not radiate. In cases of lues, Basedow, typhoid, and tuberculosis the blood apparently radiates normally (245). Test of blood taken just after the individual has been doing heavy work shows that radiation has temporarily ceased (Brainess, 28). When the blood of an animal radiates, the urine will also radiate (Siebert, 266). Gurwitsch (108) and Siebert (263) have reported tissues which as yet have been found not to give up mitogenetic radiation. These are lymph nodes, testicles, ovaries, skin, and liver. Muscle tissue is reported to be a very good sender (Frank, 78, 79, Siebert, 264); and also corneal epithelium (Gurwitsch and Anikin, 117), bone marrow (30), nerve tissue, ciliate epithelium, intestinal epithelium, spleen (110). Interesting work has been done on the corneal epithelium, where apparently the radiation depends on the radiation of the blood (for more detailed analysis of this see 117 and 135). Gurwitsch (115) reports that radiation is given up by the cornea and not by the sclera of the eye. Harders (140) finds exactly the opposite regarding these tissues of the eye. A pulp made of muscle will give up radiation if prepared from an excited muscle. A detailed analysis of muscle work has been made by Frank and Popoff (78). Lately a number of publications have appeared on the radiation of the nerve (110, 111, 136, 168, 169). This work has been done by following the spectra of the radiation emitted (see Fig. 6). Whether or not the energy available in the nerve reaction is sufficient has been discussed by Hill (145).

Protti (218, 219) reports that in the case of senility radiation of the blood disappears, but that when blood of young people has been added, radiation again reappears. This material has been reported in book form (220) and is supposed to be ready for clinical use.

A large number of biochemical reactions have been found to give mitogenetic radiation and many purely chemical reactions have been designated as good senders. As simple a reaction as the solution of NaCl

in water is reported a source of radiation, while the solution of sugar in water is not. Extensive work on chemical radiation has been reported by Wolff and Ras (308), Ruysen (237, 238), Frank (79), Audubert (6), Potozky (212), Braunstein and Potozky (32, 33), and Braunstein and Severin (34).

Before ending this review, attention should be called to the cancer problem. Since it has been reported that blood of cancerous people will not radiate and cancer tissue itself will (Gurwitsch 114, 128, 129, 133, 135, 137, Karpas and Lanschina, 153, Kisliak-Statkewitsch, 156, Siebert, 268), this has suggested a study for the extremely difficult and involved problem of cancer. We warn here against a careless optimism, which expressed itself especially in a number of popular articles and has often prejudiced the sincere worker from taking this problem seriously. It can safely be stated that even if the work on the mitogenetic-ray problem is entirely correct—and before we can accept this, many points must be cleared up—the cancer problem, as such, should be left to those who have had considerable experience with it, and if it should prove possible to put in the hands of the cancer worker good reliable detecting methods for mitogenetic rays, a great service would have been rendered. Speculation based on small amounts of material or data should be avoided. More and carefully controlled work on the fundamental methods of this problem and more reliable proof of the existence of mitogenetic rays are needed before a satisfactory evaluation can be expected.

CONCLUSIONS

The most critical investigators must admit—when going over at least the more simple experiments, and seeing the large number of positive results reported from different laboratories—that the trend of results points to some uniform effect, but the interpretation of the effect need not necessarily be what the investigators claim for it. But even a convinced believer in the existence of mitogenetic rays must admit that there are so many contradictions and slightly supported statements concerning the work that it cannot be accepted in the present form. It is clear that before the advanced work on spectral analysis can be discussed intelligently the fundamental facts must be cleared up and put on such a basis that they can be handled by any careful worker. It seems to the reviewer that more harm has been done to the mitogenetic-ray problem by its overenthusiastic supporters than by those who have maintained an interested but critical attitude toward the problem.

We have given here only a bird's-eye view of the application of mitogenetic rays. Those interested in different phases of the problem will find the available material in the literature.

The books (97, 108) published on the mitogenetic-ray problem make it very difficult to evaluate the material. There is a tendency to accept

as correct almost every article which reports positive effects—even if this work is supported by only a small number of experiments—and to cast doubt on the work of those who have not obtained positive reactions.¹

REFERENCES

1. ACS, L. Ueber die mitogenetische Strahlung der Bakterien. *Zentralbl. Bakt.* I. Abt. **120**: 116–124. 1931.
2. ACS, L. Ueber echte mitogenetische Depression. Bakterienantagonismus und mitogenetische Strahlung. *Zentralbl. Bakt.* Abt. I. **127**: 342–350. 1933. (*See also* *Ibid.* **126**: 125–127.)
3. ANIKIN, A. W. Das Nervensystem als Quelle mitogenetischer Strahlung. *Roux' Arch. Entwicklunsmech. Organ.* **108**: 609–616. 1926.
4. ANONYMOUS. Mitogenesis and ultraviolet radiation. *British Jour. Actinother.* **2**: 82–83. 1927.
5. ANONYMOUS. Mitogenetic rays. *Lancet* **219**: 312. 1930.
6. AUDUBERT, R., and VAN DOORMAL. Sur l'émission de rayonnement par les réactions chimiques. *Compt. Rend. Acad. Sci. [Paris]* **196**: 1883–1885. 1933.
7. BACHMANN, W. Ueber Fernwirkung einer Hefekultur auf Mikroorganismen. *Zentralbl. Bakt.* Abt. I. **124**: 113–122. 1932.
8. BACKOFEN, O. Wirkung mitogenetischer Strahlen auf Bakterien. *Zentralbl. Bakt.* Abt. 2. **129**: 366–368. 1933.
9. BARANY, E. Hemmung der autokatalytischen Gurwitsch-Strahlung durch selektive Absorption. *Naturwiss.* **1**: 573. 1931.
10. BARGMANN, W. Die Gurwitsch-Strahlen. *Mikrokosmos* **23**: 83–85. 1929.
11. BARNES, MARGARET N., and O. RAHN. Tötung von Hefen durch Strahlungen des menschlichen Körpers. *Arch. Mikrobiol.* **4**: 583–588. 1933.
12. BARON, M. A. Ueber mitogenetische Strahlung bei Protisten. *Roux' Arch. Entwicklunsmech. Organ.* **108**: 617–623. 1926.
13. BARON, M. A. Bakterien als Quellen mitogenetischer Strahlung. *Zentralbl. Bakt.* Abt. I. **73**: 373–379. 1928.
14. BARON, M. A. Analyse der mitogenetischen Induktion und deren Bedeutung in der Biologie der Hefe. *Planta, Arch. Wiss. Bot.* **10**: 28–83. 1930.
15. BELAR, K. Zellteilung und Strahlung. *Naturwiss.* **17**: 375–379. 1929.
16. BERGAUER, V. Quelques observations sur les radiations mito-génétiques de Gurwitsch. *Bull. Assoc. Anat.* **3**: 146–148. 1928.
17. BIDDAU, I. Studio sulle radiazioni mitogenetiche del sangue del bambino. *I. Radiobiologia* **1**: 3–17. 1932.
18. BILLIG, E., N. KANNEGIESSER, and L. SOLOWJEW. Die Spektral-analyse der mitogenetischen Strahlung bei Pepsinverdauung und bei Spaltung von Glycyl-Glycin durch Erepsin. *Hoppe-Seyler's Zeitsch. Physiol. Chem.* **210**: 220–227. 1932.
19. BLACHER, L., and N. BROMLEY. Resorptionsprozesse als Quelle der Formbildung. I. Die Rolle der mitogenetischen Strahlung im Prozesse der Meta-

¹The author wishes to express his thanks to those investigators at work on this problem who have given him the opportunity to discuss it with them. Since the bibliography was prepared, and up to September, 1935, more than 120 additional articles on the mitogenetic problem have appeared. Special attention should be directed to two reviews in English, as follows:

BATEMAN, J. B. Mitogenetic radiation. *Biolog. Rev.* **10**: 42–71. 1935.

HOLLAENDER, ALEXANDER, and WALTER D. CLAUS. Some phases of the mitogenetic ray phenomenon. *Jour. Opt. Soc. Amer.* **25**: 270–286. 1935.

- morphose der schwanzlosen Amphibien. Roux' Arch. Entwicklunsmech. Organ. **122**: 48-78. 1930. (*See also* Ibid. **122**: 79-87).
20. BLACHER, L., and N. BROMLEY. Resorptionsprozesse als Quelle der Formbildung. IV. Mitogenetische Ausstrahlungen bei der Schwanz-regeneration der Urodelen. Roux' Arch. Entwicklunsmech. Organ. **123**: 240-265. 1930. (*See also* Ibid. **123**: 230-239.)
 21. BLACHER, L. J., O. G. HOLZMANN, L. D. LIOSNER, and M. A. WORONZOWA. Resorptionsprozesse als Quelle der Formbildung. IX. Einfluss der mitogenetischen Strahlen auf die Geschwindigkeit der Regeneration. Roux' Arch. Entwicklunsmech. Organ. **127**: 339-352. 1932. (*See also* Ibid. **127**: 353-363.)
 22. BLACHER, L. J., O. G. HOLZMANN, L. D. LIOSNER, and M. A. WORONZOWA. Studien über mitogenetische Strahlung des Blutes. II. Weitere Untersuchungen über mitogenetische Blutstrahlung während der Amphibien Metamorphose. Radiobiologia **1**: 19-27. 1933.
 23. BLACHER, L. J., O. G. HOLZMANN, L. D. LIOSNER, and M. A. WORONZOWA. Ueber den Einfluss des Regenerationsprozesses eines anderen Teils. Roux' Arch. Entwicklunsmech. Organ. **127**: 370-386. 1932.
 24. BLACHER, L. T., and L. D. LIOSNER. Studien über mitogenetische Strahlung des Blutes. I. Mitogenetische Blutstrahlung der Amphibien während der Metamorphose. Roux' Arch. Entwicklunsmech. Organ. **127**: 364-369. 1932.
 25. BLACHER, L., and W. SAMARZJEW. Die Organisationszentren der Hydra fusca L. als Quelle mitogenetischer Strahlung. Biol. Zentralbl. **50**: 624-632. 1930.
 26. BLACHER, L. J., M. A. WORONZOWA, L. D. LIOSNER, and W. N. SAMARAJEW. Resorptionsprozesse als Quelle der Formbildung. VII. Die mitogenetischen Ausstrahlungen als Stimulus des Wachstums des Vorderbeines bei der Metamorphose von *Rana temporaria*. Roux' Arch. Entwicklunsmech. Organ. **124**: 138-153. 1931.
 27. BORODIN, D. N. Energy emanation during cell division processes (M-rays). Plant Physiol. **5**: 119-129. 1930.
 28. BRAINESS, S. Die mitogenetische Strahlung als Methode zum Nachweis und Analyse der Ermüdungserscheinungen. Arbeitsphysiol. **6**: 90-104. 1932.
 29. BRAUL, J. Ueber einige Ursachen der atypischen Mitosen im Zusammenhang mit der Lehre von den mitogenetischen Strahlen. Vopr. Ontol. **3**: 21-22. 1930.
 30. BRAUNER, R., and EUGENIE SORU. Variations, en fonction du temps, de l'effet mitogénétique produit par le Bacillus tumefaciens sur la moelle osseuse du lapin. Compt. Rend. Soc. Biol. [Paris] **112**: 1122-1124. 1933. (*See also* Ibid. **114**: 297-299.)
 31. BRAUNSTEIN, A. E., and P. A. HEYFETZ. Glykolyse und die mitogenetische Strahlung des Blutes bei experimentalem Carcinom. Biochem. Zeitsch. **259**: 175-179. 1933.
 32. BRAUNSTEIN, A. E., and ANASTASIE POTOZKY. Untersuchungen über den Chemismus der mitogenetischen Strahlung. I. Biochem. Zeitsch. **249**: 270-281. 1932.
 33. BRAUNSTEIN, A. E., and ANASTASIE POTOZKY. Untersuchungen über den Chemismus der mitogenetischen Strahlung. IV. Biochem. Zeitsch. **268**: 422-443. 1934.
 34. BRAUNSTEIN, A. E., and B. A. SEVERIN. Untersuchungen über den Chemismus der mitogenetischen Strahlung. III. Biochem. Zeitsch. **255**: 38-43. 1932.
 35. BROMLEY, N. Resorptionsprozesse als Quelle der Formbildung. VI. Der Einfluss der primären Verheilung der Wunde auf die Entstehung mitogenetischer Ausstrahlungen in ihr. Roux' Arch. Entwicklunsmech. Organ. **123**: 274-278. 1930.

36. BRUNETTI, R. Punto di vista fisico relativamente all'effetto Gurwitsch. Riv. Radiol. e Fis. Med. **4**: 247-267. 1932.
37. BRUNETTI, R., and C. MAXIA. Sulla fotografia et la eccitazione della radiazioni del Gurwitsch. Atti Soc. Cult. Sci. Med. e Nat. [Cagliari] **2**: 1930.
38. BURGERS, and W. BACHMANN. Fernwirkung von Hefekulturen auf verschiedene Mikroorganismen. Klin. Wochensh. **1**: 773-775. 1931.
39. BYRUKOV, D. Ueber Gurwitschs mitogenetische Strahlen. Russk. Fiziol. Zeitsch. **9**: 499-502. 1926.
40. CASATI, A. Ricerche sperimentali sul potere radiante del sangue nell' Ergosterismo. Radiobiologia **7**: 6-11. 1932.
41. CASTALDI, L. Radiazioni mitogenetiche. Atti Soc. Cult. Sci. Med. e Nat. **31**: 63-68. 1929.
42. CASTALDI, L. Stato attuale delle conoscenze sulle radiazioni vitali. Morgagni **73**: 147-159. 1931.
43. CASTALDI, L. Sulla comunicazione di Brunetti e Maxia. Atti Soc. Cult. Sci. Med. e Nat. **5**: 54-56. 1930.
44. CASTALDI, L. Bibliografia sulla radiazioni "mitogenetiche." Scritti Biolog. **6**: 184-194. 1931.
45. CASTALDI, L. Ulteriori studi sulle radiazioni "mitogenetiche." I. Bibliografia. Pubblicazioni della Stazione biologica in San Bartolomeo [Cagliari] No. 25. 1931.
46. CASTALDI, L., and C. MAXIA. Radiazioni mitogenetiche; radiazioni, "cosmeche." Mon. Zool. Ital. **40**: 418-421. 1929.
47. ČECH, A. Gurwitschs Strahlen und deren Zusammenhang mit den lytischen Fermenten und Rachitis (Tchech). Čas. Lék. Česk. **70-74**. 1932. (See also *Ibid.* p. 585-587.)
48. CHARITON, J., G. FRANK, and N. KANNEGIESSER. Ueber die Wellenlänge und Intensität mitogenetischer Strahlung. Naturwiss. **18**: 411-417. 1930.
49. CHOUCROUN, N. Sur l'hypothèse du rayonnement mitogénétique. Annales Physiol. **6**: 331-345. 1930. (See also *Compt. Rend. Acad. Sci. [Paris]* **189**: 782-784. 1929; *Ibid.* **192**: 1674-1676. 1931.)
50. CHOUCROUN, N. On the hypothesis of mitogenetic radiation. Jour. Marine Biol. Assoc. U. Kingd. **17** (No. 1): 1930.
51. CHRISTIANSEN, W. Das Menotoxinproblem und die mitogenetischen Strahlen. Ber. Deut. Bot. Ges. **47**: 357-370. 1929. (See also *Deut. Physiol. Ges. [Kiel] Tagung*, May 22-24. 1929.)
52. CHRUSTSCHOFF, G. K. Ueber die Ursachen des Gewebewachstums in vitro. I. Die Quellen der mitogenetischen Strahlen in Gewebekulturen. Arch. Exp. Zellforsch. **9**: 203-213. 1930.
53. CLERICI, A. Le radiazioni mitogenetiche. Gazz. Osp. e Clin. **1**: 1-3. 1930.
54. CLUZET, J., and T. KOFMAN. De l'action des différentes radiations sur les anceaux de Liesegang. *Compt. Rend. Soc. Biol. [Paris]* **104**: 1001-1003. 1930.
55. COPISAROW, M. Radiation and enzyme activity. Nature **130**: 1001-1002. 1932.
56. COPISAROW, M. Metabolic oxidation and radiation. Protoplasma **21**: 73-80. 1934.
57. CORI, MARIA. Effetto Gurwitsch. Notaprev. Atti Accad. Sci. Med. e Nat. [Ferrara] **2** s. 7, 8, 45-62. 1932. II 5.
58. CREMONESE, G. I raggi della vila fotografati. Roma (Ed. Paolo Cremonese) [Roma] p. 80. 1930.
59. CZAJA, A. TH. Zur Frage der Beeinflussung der Liesegangschen Ringbildung durch Zwiebelsohlenbrei. Biol. Zentralbl. **50**: 577-581. 1930.
60. DESSAUER, F. Bemerkung über den physikalischen Nachweis der mitogenetischen Strahlung von Gurwitsch. Arch. Exp. Zellforsch. **11**: 33-37. 1931.

61. DANIELS, F. The radiation hypothesis of chemical reaction. *Chem. Rev.* **5**: 39-66. 1928.
62. DHÉRÉ, CH. L'absorption des rayons ultraviolets par les acides nucléiques au point de vue chimique et au point de vue cytologique. *Compt. Rend. Soc. Biol. [Paris]* **101**: 1124-1128. 1929.
63. DOLJANSKI, L. Das Wachstum der Gewebeskulturen in vitro und die Gurwitsch-Strahlung. *Roux' Arch. Entwicklungsmech. Organ.* **126**: 207-212. 1932.
64. DORFMAN, W., and W. SARAFANOW. Mitogenetische Strahlung und Befruchtung. *Protoplasma* **15**: 616-619. 1932.
65. DORFMAN, W. A., and J. SCHMERLING. Rhythm of mitogenetic radiation in the developing sea-urchin egg. *Protoplasma* **19**: 170-176. 1933.
66. DVEZANSKI, LEONID. Das Wachstum der Gewebeskulturen in vitro und die Gurwitschstrahlung. *Roux' Arch. Entwicklungsmech. Organ.* **126**: 207-212. 1932.
67. EDITORIAL. Mitogenetic rays. *Lancet* **218**: 1416. 1930.
68. ELGER, LUBOR. Die Bedingungen für die photographische Aufnahme der Gurwitschschen Strahlen (Techech). *Čas. Lék. Česk. p.* 418-421. 1932. (*See also* *Ibid.* p. 833-837.)
69. ELGER-SVORCIKOWA-BARDOS. Ueber die Wirkung der mitogenetischen Strahlung auf die Bildung von Liesegangschen Ringen. *Biologia Gen.* **7**: 605-620. 1931.
70. EUGSTER, J. Zur Frage der biologischen Wirkungsmöglichkeit von Umgebungsstrahlung. *Arch. Exp. Zellforsch.* **13**: 108-110. 1932.
71. FERGUSON, ALICE JEAN, and O. RAHN. Zum Nachweis mitogenetischer Strahlung durch beschleunigtes Wachstum von Bakterien. *Arch. Mikrobiol.* **4**: 574-582. 1933.
72. FISCHER, E. Ultraviolette Strahlung biologischen Ursprungs. *Klin. Wochensh.* **10**: 2065-2068. 1931.
73. FONTANA LANCO, FANNY. Ulterio studi sulle radiazioni mitogenetiche. Nota VII. Alcuni interpretazione ed ipotesi. *Scritti Biol.* **7**: 443-447. 1932.
74. FRANK, G. Das mitogenetische Reizminimum und -maximum und die Wellenlänge mitogenetischer Strahlen. *Biol. Zentralbl.* **52**: 1-12. 1932.
75. FRANK, G. Ueber die Erforschung mitogenetischer Strahlung mittels einer neuen nephelometrischen Methode. *Biol. Zentralbl.* **52**: 1-12. 1932.
76. FRANK, G., and A. GURWITSCH. Zur Frage der Identität mitogenetischer und ultravioletter Strahlen. *Roux' Arch. Entwicklungsmech. Organ.* **109**: 451-454. 1927.
77. FRANK, G., and M. KUREPINA. Die gegenseitige Beeinflussung der Seeigeleier als mitogenetischer Effekt betrachtet. *Roux' Arch. Entwicklungsmech. Organ.* **121**: 634-638. 1930.
78. FRANK, G., and M. POPOFF. Die mitogenetische Strahlung des Muskels und ihre Verwertung zur Analyse der Muskelkontraktion. *Pflüger's Arch. Ges. Physiol.* **223**: 301-328. 1929.
79. FRANK, G., and S. RODIONOW. Physikalische Untersuchung mitogenetischer Strahlung der Muskeln und einiger Oxydationsmodelle. *Biochem. Zeitsch.* **249**: 323-343. 1932. (*See also* *Naturwiss.* **19**: 659. 1931.)
80. FRANK, G., and S. SALKIND. Die Quellen der mitogenetischen Strahlung im Pflanzenkeimling. *Roux' Arch. Entwicklungsmech. Organ.* **108**: 596-608. 1926.
81. FRANK, G., and S. SALKIND. Die mitogenetische Strahlung der Seeigeleier. *Roux' Arch. Entwicklungsmech. Organ.* **110**: 626-630. 1927. [*See also* *Compt. Rend. Acad. Sci. (Paris)* **185**: 1218-1219. 1927.]

82. FRANK, G., and S. SALKIND. Einige Bemerkungen zum Arbeit von M. Moisejewna "Zur Theorie der mitogenetischen Strahlung." *Biochem. Zeitsch.* **246**: 247-248. 1932.
83. GERLACH, W. Physikalisches zum Problem der mitogenetischen Strahlung. *Sitzungsber. Ges. Morphol. und Physiol.* [München] **42**: 1-10. 1933.
84. GESENIUS, H. Ueber Stoffwechselwirkungen von Gurwitschstrahlen. *Biochem. Zeitsch.* **225**: 358-367. 1930. (*See also* *Ibid.* **212**: 240. 1929.)
85. GESENIUS, H. Ueber die Gurwitschstrahlung menschlichen Blutes und ihre Bedeutung für die Careinomdiagnostik. *Biochem. Zeitsch.* **226**: 257-272. 1930. (*See also* *Radiobiologia* **1**: 33-36. 1932.)
86. GESENIUS, H. Zur Analyse der Blut-Fernwirkung nach Gurwitsch. *Arch. Gynäkol.* **163**: 468-481. 1933.
87. GIGON, A., and M. NOVERAZ. Organe als Strahlensender. *Schweiz. Med. Wochensh.* **60**: 584-590. 1930.
88. GLANFERRARI, L. Che cosa sono i raggi mitogenetici? *Natura* **21**: 167-175. 1930.
89. GOLYSCHewa, K. P. Die mitogenetische Spektralanalyse der Blutstrahlung am lebenden Tier. *Biochem. Zeitsch.* **260**: 52-57. 1933. [*See also* *Arch. Sci. Biol.* (Leningrad) **33**: 107-114. 1933.]
90. GREY, J., and C. OUELLET. Apparent mitogenetic inactivity of active cells. *Proc. Roy. Soc.* [London] B **114**: 1-9. 1933.
91. GUILLERY, H. Ueber Bedingungen des Wachstums auf Grund von Untersuchungen an Gewebekulturen. *Virehow's Arch.* **270**: 311-359. 1929.
92. GURWITSCH, A. Ueber Ursachen der Zellteilung. *Roux' Arch. Entwicklun-gsmech. Organ.* **52**: 167-181. 1922.
93. GURWITSCH, A. Die Natur des spezifischen Erregers der Zellteilung. *Arch. Mikrosk. Anat. und Entw. Mech.* **100**: 11-40. 1923.
94. GURWITSCH, A. Physikalisches über mitogenetische Strahlen. *Arch. Mikrosk. Anat. und Entw. Mech.* **103**: 490-498. 1924.
95. GURWITSCH, A. Les problèmes de la mitose et les rayons mitogénétiques. *Bull. Histol. Appl.* **1**: 486-497. 1924.
96. GURWITSCH, A. Sur le rayonnement mitogénétique des tissus animaux. *Compt. Rend. Biol.* [Paris] **91**: 87-88. 1924.
97. GURWITSCH, A. Das Problem der Zellteilung physiologisch betrachtet. p. 221. Julius Springer; Berlin, 1926.
98. GURWITSCH, A. Einige Fragen der mitogenetischen Strahlung. *Zeitsch. Russk. Bot. Obse.* **13**: 179-1928.
99. GURWITSCH, A. Les problèmes de la mitose et les rayons mitogénétiques. Exposé général. *Bull. Histol. Appl.* **5**: 210-219. 1928.
100. GURWITSCH, A. Some problems of mitogenetic rays. *Journ. Soc. Russie Acad. Sci.* **13**: 170. 1928.
101. GURWITSCH, A. Einige Bemerkungen zur vorangehenden Arbeit von Heern V. Rossmann. *Roux' Arch. Entwicklun-gsmech. Organ.* **113**: 406-413. 1928.
102. GURWITSCH, A. Die mitogenetische Strahlung aus den Blättern von Sedum (latifolium). Eine Erwiderung an G. Haberlandt. *Biol. Zentralbl.* **49**: 449-451. 1929.
103. GURWITSCH, A. Methodik der mitogenetischen Strahlenforschung. *Abderhalden's Biol. Arbeitsmeth. Abt. 5, T. 2/2* p. 1401-1470. 1929.
104. GURWITSCH, A. Ueber den derzeitigen Stand des Problems der mitogenetischen Strahlung. *Protoplasma* **6**: 449-493. 1929.
105. GURWITSCH, A. Bemerkungen zur Arbeit von J. Schreiber u. W. Friedrich: Ueber Nachweis und Identität der mitogenetischen Strahlung. *Biochem. Zeitsch.* **230**: 505. 1930. (*See also* *Ibid.* **229**: 109-114. 1930.)

106. GURWITSCH, A. Die fundamentalen Gesetze der mitogenetischen Erregung. Arch. Exp. Zellforsch. **11**: 3-20. 1931. (See also Naturwiss. **19**: 423-424. 1931.)
107. GURWITSCH, A. Die Fortpflanzung des mitogenetische Erregungszustandes in den Zwiebelwurzeln. Roux' Arch. Entwicklungsmech. Organ. **124**: 357-368. 1931.
108. GURWITSCH, A. Die mitogenetische Strahlung. Zugleich 2. Bd. Probleme d. Zellteilung. Unter Mitwirkung v. Lydia Gurwitsch. 384 p. Julius Springer; Berlin, 1932.
109. GURWITSCH, A. Die mitogenetische Strahlung der pflanzlichen und tierischen Meristeme. Radiobiologia **1**: 15-19. 1932.
110. GURWITSCH, A. Die mitogenetische Strahlung der markhaltigen Nerven. Pflüger's Arch. Ges. Physiol. **231**: 234-237. 1932.
111. GURWITSCH, A. Die mitogenetische Strahlung der optischen Bahn bei adäquater Erregung. Pflüger's Arch. Ges. Physiol. **231**: 255-264. 1932.
112. GURWITSCH, A. Die neuen mitogenetischen Methoden. Naturwiss. **20**: 522-523. 1932.
113. GURWITSCH, A. Excitants de la division cellulaire. Congr. Internatl. de Lutte Scientif. et. Sociale contre le Canc. pp. 3-13. Madrid, 1933.
114. GURWITSCH, A. Analyse des Chemismus der mitogenetischen Blutaussstrahlung. Fiziol. Zeitsch. **16**: 495-500. 1933.
115. GURWITSCH, A. Einige Bemerkungen zum Aufsätze "On the Gurwitsch-radiation of the eye." Acta Brev. Néerl. Physiol. **3**: 127-128. 1933.
116. GURWITSCH, A. Mitogenetic radiation of nerve. Nature **131**: 512-513. 1933.
117. GURWITSCH, L., and A. ANIKIN. Das Cornealepithel als Detektor und Sender mitogenetischer Strahlung. Roux' Arch. Entwicklungsmech. Organ. **113**: 731-739. 1928.
118. GURWITSCH, A., and G. FRANK. Sur les rayons mitogénétiques et leur identité avec les rayons ultra-violetes. Compt. Rend. Acad. Sci. [Paris] **184**: 903-905. 1927.
- 118a. GURWITSCH, A., S. GRABJE, and S. SALKIND. Arch. Ent. Mech. **100**: 11-40. 1923.
119. GURWITSCH, A., and L. GURWITSCH. Ueber die präsumierte Wellenlänge mitogenetischer Strahlen. Roux' Arch. Entwicklungsmech. Organ. **105**: 473-474. 1925. (See also Ibid. **105**: 470-472. 1925.)
120. GURWITSCH, A., and L. GURWITSCH. Weitere Untersuchungen über mitogenetische Strahlung. Arch. Mikrosk. Anat. und Entw. Mech. **104**: 109-115. 1925.
121. GURWITSCH, A., and L. GURWITSCH. Die Produktion mitogener Stoffe im erwachsenen tierischen Organismus. Roux' Arch. Entwicklungsmech. Organ. **107**: 829-832. 1926.
122. GURWITSCH, A., and L. GURWITSCH. Sur le rayonnement mitogénétique secondaire. Compt. Rend. Acad. Sci. [Paris] **184**: 841-843. 1927.
123. GURWITSCH, A., and L. GURWITSCH. Die mitogenetische Strahlung des Carcinoms. II. Zeitsch. Krebsforsch. **29**: 220-233. 1927.
124. GURWITSCH, A., and L. GURWITSCH. (unter Mitwirkung von LAPZINKI, MARTINOFF, SALKIND, FRANK). Ueber ultraviolette Chemoluminescenz der Zellen im Zusammenhang mit dem Problem des Carcinoms. Biochem. Zeitsch. **196**: 257-275. 1928.
125. GURWITSCH, A., and L. GURWITSCH. Zur Energetik der mitogenetischen Induktion und Zellteilungsreaktion. Roux' Arch. Entwicklungsmech. Organ. **113**: 740-752. 1929.

126. GURWITSCH, A., and L. GURWITSCH. Die mitogenetische Spektralanalyse. IV. Biochem. Zeitsch. **246**: 124-126. 1932.
127. GURWITSCH, A., and L. GURWITSCH. Die Fortleitung des mitogenetischen Effektes in Lösungen und die Beziehungen zwischen Fermenttätigkeit und Strahlung. Biochem. Zeitsch. **246**: 127-133. 1932.
128. GURWITSCH, A., and L. GURWITSCH. Die mitogenetische Strahlung und die Autokatalyse der Krebszelle. Zeitsch. Krebsforsch. **36**: 319-341. 1932.
129. GURWITSCH, A., and L. GURWITSCH, G. FRANK, S. SALKIND, A. ANIKIN, W. DOKUTSCHAEWA, and M. SERNOWA. Ueber ultraviolette Chemoluminescenz der Zellen im Zusammenhang mit dem Problem des Carcinoms. Biochem. Zeitsch. **196**: 257-275. 1928.
130. GURWITSCH, A., L. GURWITSCH, and M. KISLIAK-STATKEWITSCH. Sur le rayonnement mitogénétique du cancer. Compt. Rend. Soc. Biol. [Paris] **100**: 1080-1083. 1929.
131. GURWITSCH, A., L. GURWITSCH, and PERPELLINA. Zur Analyse der Latenzperiode der Zellteilungsreaktion. Roux' Arch. Entwicklunsmech. Organ. **109**: 362-379. 1927.
132. GURWITSCH, A., and N. GURWITSCH. Fortgesetzte Untersuchungen über mitogenetische Strahlung und Induktion. Arch. Mikrosk. Anat. und Entw. Mech. **103**: 68-79. 1924.
133. GURWITSCH, A., and W. RAVIN. Weitere Beiträge zur Kenntnis der mitotischen Ausstrahlung und Induktion. Roux' Arch. Entwicklunsmech. Organ. **101**: 53-61. 1924.
134. GURWITSCH, L. Untersuchungen über mitogenetische Strahlen. Arch. Mikrosk. Anat. und Entwickl. **103**: 483-489. 1924.
135. GURWITSCH, L. Die mitogenetische Spektralanalyse. II. Biochem. Zeitsch. **236**: 425-431. 1931.
136. GURWITSCH, L. Le spectre mitogénétique des fibres proprioceptives du nerf. Annales Physiol. et Physiochem. Biol. **10**: 141. 1934.
137. GURWITSCH, L., and S. SALKIND. Das mitogenetische Verhalten des Blutes Karzinomatöser. Biochem. Zeitsch. **211**: 362-372. 1929.
138. GUTTENBERG, H. V. Die Theorie der mitogenetischen Strahlen. Biolog. Zentralbl. **48**: 31-39, 1928. (See also Roux' Arch. Entwicklunsmech. Organ. **113**: 414-418. 1929.)
139. HABERLANDT, G. Ueber "mitogenetische Strahlung." Biol. Zentralbl. **49**: 226-230. 1929.
140. HARDERS, W. On the "Gurwitsch-radiation" of the eye. Acta Brev. Néerl. **3**: 1-4, 95. 1933.
141. HARVEY, E. N. The nature of animal light. 120 pp. Lippincott; Philadelphia, 1920.
142. HAUER, FR. Ueber mitogenetische Strahlung. Verh. Deut. Physikal. Ges. **13**: 11. 1932.
143. HEINEMANN, M. Cytagenin und mitogenetische Strahlung des Blutes. Klin. Wochensh. **2**: 1375-1378. 1932.
144. HEINEMANN, M., and R. SEYDERHELM. Weitere Untersuchungen über die mitogenetische Strahlung des Blutes unter besonderer der "Strahlungen" des Blutes von Carcinomkranken. Klin. Wochensh. **1**: 990. 1933.
145. HILL, A. V. The physical nature of the nerve impulse. Nature **131**: 501-508. 1933.
146. HOLLAENDER, A., and E. SCHOEFFEL. Mitogenetic rays. Quart. Rev. Biol. **6**: 215-222. 1931.
147. HOLZMANN, O. Resorptionsprozesse als Quelle der Formbildung. V. Mitogenetische Ausstrahlung während der Metamorphose bei Drosophila. Roux' Arch. Entwicklunsmech. Organ. **123**: 266-273. 1930.

148. HOPKINS, F. GOWLAND. Address of the President, Anniversary Meeting, November 30, 1932. Proc. Roy. Soc. [London] A **139**: 1-15. 1933.
149. ITERSÓN, G. VON, and HOMAN VAN DER HEIDE. Stempells Versuche zum Nachweis der mitogenetischen Strahlung mit Hilfe der Liesegang'schen Ringe. Proc. K. Akad. Wetensch. [Amsterdam] **33** (No. 7): 1930.
150. JAEGER, C. H. Der Einfluss der Blutstrahlung auf die Gewebeskultur. Zeitsch. Zellforsch. **12**: 354. 1930.
151. KALENDAROFF, G. S. Die Spektralanalyse der Strahlung des markhaltigen Nerven im Ruhezustande und bei künstlicher Erregung. Pflüger's Archiv. Ges. Physiol. **231**: 238-251. 1933.
152. KANNEGIESSER, NINA. Die mitogenetische Spektralanalyse. I. Introduction by A. Gurwitsch. Biochem. Zeitsch. **236**: 415-424. 1931.
153. KARPASS, A. M., and M. N. LANSCHINA. Mitogenetische Strahlung bei Eiweissverdauung. Biochem. Zeitsch. **215**: 337-343. 1929.
154. KARPASS, A. M., and M. N. LANSCHINA. Ueber den Verlust des mitogenetischen Strahlungsvermögens des Blutes. Biochem. Zeitsch. **253**: 313-317. 1932.
155. KISLIK-STATKEWITSCH, MARIE. Das mitogenetische Strahlungsvermögen des Kartoffelleptoms. Roux' Arch. Entwicklungsmech. Organ. **109**: 283-286. 1927.
156. KISLIK-STATKEWITSCH, MARIE. Die mitogenetische Strahlung des Carcinoms. Zeitsch. Krebsforsch. **29**: 214-219. 1929.
157. KLEMPERER, F. Über die "mitogenetische Strahlung." Ther. Gegenw. **74**: 557-559. 1933.
158. KLENITSKY, J. Die mitogenetische Strahlung der weissen Blutelemente. Biochem. Zeitsch. **252**: 126-130. 1932.
159. KLENITSKY, J. Die mitogenetische Strahlung des Carcinoms. Zeitsch. Krebsforsch. **39**: 60-65. 1933.
160. KLENITSKY, J. S., and F. G. PROKOFIEWA. Mitogenetische Spektralanalyse des Polysaccharidabbaus. Biochem. Zeitsch. **265**: 375-379. 1933.
161. KOFMAN, TH. Action des radiations sur les anneaux de Liesegang. Jour. Chim. Physique **29**: 586-598. 1932.
162. KONARSKI, J. Wellenlänge der mitogenetischen Strahlen. Acta. Biol. Exp. [Warsaw] **1**: 276-282. 1932.
163. KOWARZYK, H. Ueber die Fernwirkung von Zwiebelsohlenbrei auf Kolloide und über den Nachweis mitogenetischen Strahlungen. Acta Biol. Exp. [Warsaw] **6**: 29-34. 1930.
164. KOWARZYK, H., and ST. LACH. Einfluss der Gurwitschstrahlen auf die Phagozytose von Bakterien. Biol. Zentralbl. **52**: 684-697. 1932.
165. KRONENBERGER, P. Die Beeinflussung von Liesegang'schen Ringen durch ultraviolette Strahlen. 2e Cong. Intern. Lum. [Copenhagen] p. 621-626. 1932.
166. KUIHN, K. Die biologischen Strahlen. Umschau 1930: 904-906.
167. KURAJEFF, E. A. Die Zeitkurve des mitogenetischen Effektes des Hefedetektors. Roux' Arch. Entwicklungsmech. Organ. **124**: 613-617. 1931.
168. LATMANISOVA, L. W. Die mitogenetische Sekundärstrahlung des Nerven. Pflüger's Arch. Ges. Physiol. **231**: 265-279. 1932. (See also Naturwiss. **21**: 330. 1933. Annales Physiol. et Physiochem. Biol. **10**: 146. 1934.)
169. LATMANISOVA, L., L. MARKOVA, and J. UFLAND. Die mitogenetische Strahlung des Blutes und ihre Veränderungen bei der Arbeit. Fiziol. Zeitsch. **16**: 505-511. 1933.
170. LASNITZKI, A., and E. KLEE-RAWIDOWICZ. Zur Frage der "mitogenetischen" Induktion von Warmblüterzellen. Zeitsch. Krebsforsch. **34**: 518-525. 1931.
171. LEJHANEC, G. Mitogenetische Strahlung. Biol. Hist. **16**: 114-118. 1931.
172. LEPESCHIKIN, W. W. Nekrobiotische Strahlen. Protoplasma **20**: 232-250. 1933.

173. LIOSNER, L. D., and M. A. WORONZOWA. Ueber den Einfluss des Regenerationsprocesses eines Teiles des Organismus auf die Regeneration seines anderen Teiles. II. *Radiobiologia* **1**: 29-31. 1933.
174. LIOSNER, L. D., M. A. WORONZOWA, and A. I. WICHIMOWITSCH. Studien über mitogenetische Strahlung des Blutes. IV. *Radiobiologia* **1**: 79-88. 1933.
175. LOOS, WALTER. Untersuchungen über mitogenetische Strahlen. *Jahrb. Wiss. Bot.* **72**: 611-664. 1930.
176. LORENZ, E. Investigation on mitogenetic radiation by means of a photoelectric counter tube. *Phys. Rev.* **44**: 329. 1933. (*See also* *Publ. Health Repts.* p. 1311-1318. 1933.)
177. MAGROU, J. Radiations émises par le Bacterium tumefaciens. *Rev. Path. Vég. et Ent. Agric.* **14**: 244-246. 1927.
178. MAGROU, J. Actions biologiques à distance. *Bull. Inst. Pasteur* **28**: 393-405. 1930. (*See also* *Lutte contre cancer* **27**: 1930; *Compt. Rend. Acad. Sci. [Paris]* **190**: 84-87. 1930.)
179. MAGROU, J. A propos des rayons de Gurwitsch: quelques exemples d'actions biologiques à distance. *Arch. Exp. Zellforsch.* **11**: 56-62. 1931. (*See also* *Presse Méd.* **26**: 469-473. 1931.)
180. MAGROU, J. Action à distance et embryogénèse. *Radiobiologia* **1**: 32-37. 1932.
181. MAGROU, J., and M. MAGROU. Recherches sur les radiations mitogénétiques. *Bull. Hist. Appl.* **4**: 253-262. 1927. (*See also* *Compt. Rend. Acad. Sci. [Paris]* **184**: 905-906. 1927.)
182. MAGROU, J., and M. MAGROU. Actions à distance sur l'oeuf féconde, le sperme et l'oeuf vierge d'oursin. *Compt. Rend. Acad. Sci. [Paris]* **191**: 963-965. 1930. (*See also* *Ibid.* p. 802-804.)
183. MAGROU, J., M. MAGROU, and N. CHOUCROUN. Action à distance du Bacterium tumefaciens sur le développement de l'oeuf d'oursin. *Compt. Rend. Acad. Sci. [Paris]* **188**: 733-735. 1929.
184. MAGROU, J., M. MAGROU, and P. REISS. Action à distance sur le développement de l'oeuf d'oursin. *Compt. Rend. Acad. Sci. [Paris]* **189**: 779-782. 1929.
185. MAGROU, J., M. MAGROU, and E. ROUBAUD. Action stimulante à distance, exercée par certaines suspensions bactériennes, à travers le quartz, sur l'éclosion du moustique de la fièvre jaune. *Compt. Rend. Acad. Sci.* **192**: 1134-1136. 1931.
186. MANGOLD, E. Die Produktion von Licht. *Winters' Handb. Vergl. Physiol.* **3** (2): 225-392. 1910.
187. MARCONI, E. Ricerche sulle radiazioni mitogenetiche del sangue umano col *Micrococcus prodigiosus* come detectore. *Pathologica* **23**: 684-688. 1931. (*See also* *Ibid.* p. 758-759.)
188. MARCONI, E. Il potere radiante del sangue periferico del neonato nella prima settimana di vita. *Riv. Ital. Ginec.* **14**: 368-374. 1932.
189. MARCONI, E. Ricerche sulle radiazioni mitogenetiche. Potere radiante del sangue retroplacentare e del sangue periferico materno e fetale. *Atti Soc. Ital. Ostetr.* **30**: 503-506. 1932.
190. MARDASCHEW, S., and M. MOGILEWSKY. Der Einfluss der mitogenetischen Strahlen auf fermentative Prozesse. *Biochem. Zeitsch.* **265**: 429-436. 1933.
191. MARUTA, SANEYOSI. Über die mitogenetischen Strahlen. *Okayama-Igakkai-Lasski.* **44**: 3001-3012. 1932.
192. MAXIA, C. Conferma dell'esistenza della radiazioni mitogenetiche del Gurwitsch dimostrata sui blastomeri di *Paracentrotus lividus*. *Monit. Zool. Ital.* **40**: 115-123. 1929.
193. MAXIA, C. Gli anelli di Liesegang adoprati come detectori nelle studi sulle radiazioni mitogenetiche. *Atti Soc. Cult. Sci. Med. e Nat. [Cagliari]* **32** (N.S.5): 194-198. 1930.

194. MAXIA, C. Ulteriori studi sulle radiazioni "mitogenetiche." III. Publ. Staz. Biol. San Bartolomeo. No. 27. p. 12. 1931. (See also No. 29. 1931.)
195. MAXIA, C. Effetti diversi di radiazioni e di gas sulle anelli di Liesegang. *Radiobiologia* 7: 1-12. 1932.
196. MAXIA, C. Ulteriori studi sulle radiazioni "mitogenetiche." *Scritti Biol.* 7: 419-431. 1932.
197. MAXIA, C. and P. LEONE. Sul fenomeno delle mitoinduzione "mitogenetica." *Atti Soc. Cult. Sci. Med. e Nat. [Cagliari]* 5: 1-3. 1932.
198. MAXIA, C. and A. VACCA. Ulteriori studi sulla segmentazione di uova di *Paracentrotus lividus* sotto l'influenza di radiazioni mitogenetiche et di olii eteri. *R. Comit. Talassograf. Ital. Mem.* p. 187. 1931.
199. MELLON, R. R. and N. RASHEVSKY. Le radiazioni di luce ultravioletta. Raggi mitogenetici emessi da batteri et delle piante superiori. *Journ. Bacteriol.* 5, *Zymologica*, Bologna. 5: 63. 1930.
200. MOISSEJEWA, M. Gurwitsch's mitogenetic rays. *Ukrainian Bot. Rev.* 5: 41-55. 1929.
201. MOISSEJEWA, M. Zur Theorie der mitogenetischen Strahlung. Weitere Untersuchungen. *Biochem. Zeitsch.* 243: 67-87. 1931. (See also *Ibid.* 241: 1-13. 1931.)
202. MOISSEJEWA, M. Zur Theorie der mitogenetischen Strahlung. III. *Biochem. Zeitsch.* 251: 133-140. 1932.
203. MOSCHINI, ST. Rapporto fra potere radiante e riserva alcalina del sangue in talune malattie dei bambini. *Radiologia* 1: 9-18. 1933.
204. NAKAIDZUMI, M., and H. SCHREIBER. Untersuchungen über das mitogenetische Strahlungsproblem. II. *Biochem. Zeitsch.* 237: 358-379. 1931.
205. NAVILLE, A. Les rayons mitogénétiques. Exposé de quelques résultats. *Rev. Suisse Zool.* 36: 213-215. 1929. (See also *Mem. Soc. Physiol. et Hist. Nat. [Genève]* 46. 1929.)
206. PAUL, MARGARETE. Zwiebelwurzeln als Detektoren bei Untersuchungen über die mitogenetische Strahlung. Eine methodologische Untersuchung. *Roux' Arch. Entwicklunsmeeh. Organ.* 128: 108-165. 1933.
207. PETRI, L. Sopra le radiazioni mitogenetiche del Gurwitsch. *R. C. Accad. Lincei Ser. VI*, 7: 891-896. 1928.
208. PETRI, L. Di un metodo fotoelettrico per mettere in evidenza le radiazioni mitogenetiche del Gurwitsch. *R. C. Accad. Lincei Ser. VI*. 15: 919-925. 1932.
209. PETRI, L. Nachweis der mitogenetischen Strahlung durch eine physikalische Strahlung. *Protoplasma* 19: 365-369. 1933.
210. POLITZER, G. Die Wachstumsstrahlen. *Wien. Klin. Wochensh.* 2: 1277-1279. 1929.
211. PONOMAREWA, J. Die mitogenetische Spektralanalyse. III. *Biochem. Zeitsch.* 239: 424-429. 1931.
212. POTOZKY, A. Untersuchungen über den Chemismus der mitogenetischen Strahlung. II. *Biochem. Zeitsch.* 249: 282-287.
213. POTOZKY, A. Die Beeinflussung des mitogenetischen Effekts durch sichtbares Licht. II. *Biol. Zentrabl.* 52: 129-138. 1932. (See also *Ibid.* 50: 712-723. 1930; 51: 465-468. 1931.)
214. POTOZKY, A., S. SALKIND, and J. ZOGLINA. Die mitogenetische Strahlung des Blutes und der Gewebe von Wirbellosen. *Biochem. Zeitsch.* 217: 178-184. 1930.
215. POTOZKY, A., and I. ZOGLINA. Ueber mitogenetische Sekundärstrahlung aus abgeschnittenen Zwiebelwurzeln. *Roux' Arch. Entwicklunsmeeh. Organ.* 114: 1-8. 1928.
216. POTOZKY, A., and I. ZOGLINA. Untersuchungen über mitogenetische Strahlung des Blutes. *Biochem. Zeitsch.* 211: 352-361. 1929.

217. POZZAN, ANGELO. Emocateresi e raggi mitogenetici. *Radiobiologia* **1**: 68-71. 1932.
218. PROTTI, G. Di un apparecchio per la determinazione biologica della azione irradiante germinatrice del sangue (azione mitogenetica di Gurwitsch). Comunicazione alla XIX riunione della societa Venezia-Tridentina. 1930. (*See also* "Involutione senile." *Ibid.* 1930.)
219. PROTTI, G. I raggi mitogenetici nell'emoinnesto e prime loro fotografie. *Communic.* Seduta Sci. Ospedale Civ. [Venezia] 1930. (*See also* "Impressioni." *Ibid.* 1930.)
220. PROTTI, G. L'emoinnesto intramuscolare e la radiazioni vitali nella recchiaia e nell'esaurimento. 140 p. Ulrico Hoepli; Milano, 1931.
221. PROTTI, G. Effetti fotografici intraorganici. *Radiobiologia* **1**: 61-65. 1932.
222. RAJEWSKY, B. Anordnung zur Messung kleinster Lichtintensitäten. *Zeitsch. Phys.* **63**: 576. 1930.
223. RAJEWSKY, B. Eine neue Messanordnung für kleinste Lichtintensitäten. *Strahlentherapie* **39**: 194-200. 1930. (*See also* *Phys. Zeitsch.* **32**: 121. 1931.)
224. RAJEWSKY, B. Zur Frage physikalischen Nachweises der Gurwitsch-Strahlen. *In* "Zehn Jahre Forschung auf dem Physikal.-Med. Grenzgebiet." George Thieme; Leipzig, 1931.
225. RAJEWSKY, B. Ultraviolet-Strahlung des Eiweisses. *Klin. Wochensch.* **10**: 1672-1673. 1931.
226. RAJEWSKY, B. Zum Problem der mitogenetischen Strahlung. *Zeitsch. Krebsforsch.* **35**: 387-394. 1932.
227. RAJEWSKY, B. Zur Mitteilung von W. W. Siebert, und H. Seffert über den physikalischen Nachweis der Gurwitsch-Strahlung. *Naturwiss.* **21**: 299. 1933.
228. REISS, P. Le phénomène de Gurwitsch (la question des rayons mitogénétiques). *Arch. Phys. Biol.* **9**: 165-166. 1931.
229. REITER, T. Gurwitschstrahlen. *Klin. Wochensch.* **9**: 1842. 1930.
230. REITER, T., and D. GABOR. Ultraviolette Strahlen und Zellteilung. *Strahlentherapie* **28**: 125-131. 1928.
231. REITER, T., and D. GABOR. Zellteilung und Strahlung. *Sonderh. Wiss. Veröffentlich.* 183 p. Siemens-Konzern; Berlin, 1928.
232. REITER, T., and D. GABOR. Der heutige Stand des Problems der Gurwitsch-Strahlen. *Arch. Exp. Zellforsch.* **11**: 21-32. 1931.
233. RICHARDS, W., and G. TAYLOR. "Mitogenetic Rays"—a critique of the yeast-detector method. *Biolog. Bull.* **63**: 113-128. 1932.
234. ROSSMANN, BRUNO. Untersuchungen über die Theorie der mitogenetischer Strahlen. *Roux' Arch. Entwicklunsmech. Organ.* **113**: 346-405. 1928.
235. ROSSMANN, BRUNO. Mitogenetische Induktionsversuche mit Hefe als Indikator. *Roux' Arch. Entwicklunsmech. Organ.* **114**: 583-586. 1928.
236. RUSINOFF, P. G. Weitere Untersuchungen über mitogenetische Strahlen und Induktion. *Arch. Mikros. und Entwickl.* **104**: 121-124. 1925.
237. RUYSSSEN, R. L'émission de rayons de Gurwitsch par les réactions chimiques entre gaz. *Acad. Roy. Belgique. Bull. Cl. Sci.* **5**: 535-542. 1933.
238. RUYSSSEN, R. Sur l'énergie et les limites de longueur d'onde des rayons mitogénétiques. *Acta Brev. Néerl.* **3**: 141-142. 1933. (*See also* *Ibid.* p. 51. 1933.)
239. SALKIND, S. Weitere Untersuchungen über mitogenetische Strahlung und Induktion. *Arch. Mikrosk. Anat. und Entwickl.* **104**: 116-120. 1925.
240. SALKIND, S. Die mitogenetische Strahlung der Larve von *Saccocirrus*. *Roux' Arch. Entwicklunsmech. Organ.* **124**: 467-468. 1931.
241. SALKIND, S. Beiträge zur Analyse des mitogenetischen Effektes. I. *Roux' Arch. Entwicklunsmech. Organ.* **128**: 378-392. 1933.

242. SALKIND, S., A. POTOZKY, and I. ZOGLINA. Die mitogenetische Beeinflussung der Eier von *prato-drilus* und *saccacirrus*. Roux' Arch. Entwicklunsmech. Organ. **121**: 630-633. 1930.
243. SALKIND, S. J., and L. M. SCHABARD. Ueber die mitogenetische Strahlung des experimentellen Tierkrebses. Zeitsch. Krebsforsch. **34**: 216-227. 1931. (*See also* Vestn. Roentgenol. **9**: 359-369. 1931.)
244. SALVADORI PALEOTTI, G. Attuali conoscenze sulle radiazioni mitogenetiche. Riv. Radio. e Fisica Med. **3**: 185-206. 1931.
245. SAMARAJEW, W. N. Die mitogenetische Strahlung des Blutes bei künstlicher Hyperthyreose und bei Basedowscher Krankheit. Endokrinol. **2**: 335-343. 1932.
246. SAMARAJEW, W. N. Die mitogenetische Ausstrahlung bei der Regeneration des Regenwurmes. Roux' Arch. Entwicklunsmech. Organ. **126**: 633-635. 1932.
247. SCHAMARINA, N. Das Erlöschen der mitogenetischen Erregung der Nerven bei Begegnung zweier Erregungen. Pflügers Arch. Ges. Phys. **231**: 252-254. 1932.
248. SCHOUTEN, S. L. Gurwitsch-Strahlen und Pilzsporentenkeimung. Acta Brev. Néerl. **3**: 68. 1933.
249. SCHREIBER, H. Ueber Strahlungserscheinungen an biologischen Objekten. Zeitsch. Angew. Chem. **44**: 709-714. 1931. (*See also* Zeitsch. Ärztl. Fortbild. **27**: 730-731. 1930.)
250. SCHREIBER, H. Zur Theorie der mitogenetischen Strahlung. Protoplasma **19**: 1-25. 1933.
251. SCHREIBER, H. Strahlenbiologische Untersuchungen besonders im ultravioletten Spektralbezirk an *Saccharomyces turbicans* Hansen. Strahlentherapie **49**: 541-595. 1934.
252. SCHREIBER, H., and W. FRIEDRICH. Ueber Nachweis und Intensität der mitogenetischen Strahlung. Biochem. Zeitsch. **227**: 386-400. 1930.
253. SCHREIBER, H., and A. LUNTZ. Mitogenetische Strahlung. Tab. Biol. Period. **1**: 285-299. 1931.
254. SCHREIBER, H., and M. NAKAIDZUMI. Untersuchungen über das mitogenetische Strahlungsproblem. III. Biochem. Zeitsch. **247**: 161-170. 1932.
255. SCHWARTZ, WALTER. Das Problem der mitogenetischen Strahlen. Biol. Zentralbl. **48**: 302-308. 1928.
256. SCHWEMMLE, J. Mitogenetische Strahlen. Biol. Zentralbl. **49**: 421-437. 1929.
257. SEIFRIZ, W. The Gurwitsch Rays. *In the Science of Radiology*. Thomas; Springfield, 1933. (*See* pp. 412-427.)
258. SEWERTZOWA, L. B. Ueber den Einfluss der mitogenetischen Strahlung auf die Vermehrung der Bakterien. Biol. Zentralbl. **49**: 212-225. 1928.
259. SEWERTZOWA, L. B. Influence du rayonnement mitogénétique sur la vitesse de multiplication des bactéries. Annales Inst. Pasteur **46**: 337-371. 1931.
260. SEYDERHELM, R., and M. HEINEMANN. Ueber Beziehungen zwischen Cytagenin, Heliotherapie und mitogenetische Strahlung des Blutes. 2e Congr. Intern. Lum. [Copenhagen] p. 740. 1932.
261. SEYFERT, FRANZ. Ueber den physikalischen Nachweis von mitogenetischen Strahlen. Jahrb. Wiss. Bot. **76**: 747-764. 1932.
262. SIEBERT, W. W. Ueber eine neue Beziehung von Muskeltätigkeit und Wachstumsvorgängen. Zeitsch. Klin. Med. **109**: 360-370. 1928. (*See also* Klin. Wochensh. **7**: 198. 1928.)
263. SIEBERT, W. W. Ueber die mitogenetische Strahlung des Arbeitsmuskels und einiger anderer Gewebe. Biochem. Zeitsch. **202**: 115-122. 1928. (*See also* *Ibid.* p. 123-130.)
264. SIEBERT, W. W. Aktionsstrahlung des Muskels und Wachstumswirkung des elektrodynamischen Feldes. Biochem. Zeitsch. **215**: 152-161. 1929.

265. SIEBERT, W. W. Das Stempell-Phänomen an den Liesegang'schen Ringen. *Biochem. Zeitsch.* **220**: 487-492. 1930.
266. SIEBERT, W. W. Die mitogenetische Strahlung des Blutes und des Harns gesunder und kranker Menschen. *Biochem. Zeitsch.* **225**: 253-256. 1930.
267. SIEBERT, W. W. Zur Wachstumswirkung des Arbeitsmuskels. *Biol. Gen.* **7**: 69-70. 1931.
268. SIEBERT, W. W. Untersuchungen über mitogenetische Strahlen. *Strahlentherapie* **40**: 780-783. 1931. (*See also Arch. Exp. Zellforsch.* **11**: 52-55. 1931.)
269. SIEBERT, W. W., and H. SEFFERT. Physikalischer Nachweis der Gurwitsch Strahlung mit Hilfe eines Differenzverfahrens. *Naturwiss.* **31**: 193-194. 1933.
270. SORIN, A. N. Zur Analyse der mitogenetischen Induktion des Blutes. *Roux' Arch. Entwicklunsmech. Organ.* **108**: 634-645. 1926.
271. SORIN, A. N., and M. KISLIAK-STATKEWITSCH. Ueber mitogenetische Induktion in den frühen Entwicklungsstadien des Hühnerembryo. *Roux' Arch. Entwicklunsmech. Organ.* **113**: 724-730. 1928.
272. SORU, E., and R. BRAUNER. Action à distance du Bacille phosphorescent sur la moelle osseuse. *Compt. Rend. Soc. Biol. [Paris]* **111**: 201-203. 1932.
273. SORU, E., and R. BRAUNER. Action à distance de Bacillus tumefaciens sur la moelle osseuse du lapin. *Compt. Rend. Soc. Biol. [Paris]* **112**: 623-625. 1933.
274. SORU, E., and R. BRAUNER. Nouvelle contribution à l'étude des actions à distance sur la moelle osseuse du lapin. *Compt. Rend. Soc. Biol. [Paris]* **114**: 1201-1202. 1933.
275. STEMPELL, W. Ueber eine bisher unbekannte Eigenschaft lebender Substanz. *Sitzungsber. Naturwiss. Med. Ges. [Münster]* 1928.
276. STEMPELL, W. Die Lebensstrahlen. *Strahlentherapie* **34**: 868-875. 1929.
277. STEMPELL, W. Nachweis der von frischem Zwiebelsohlenbrei ausgesandten Strahlen durch Störung der Liesegang'schen Ringbildung. *Biol. Zentralbl.* **49**: 607-615. 1929. (*See also Ibid.* **50**: 248-252. 1930; *Umschau* **34**: 982-984. 1930.)
278. STEMPELL, W. Das Wasserstoffsperoxyd als Detektor für Organismenstrahlung und Organismengasung. *Protoplasma* **12**: 538-548. 1931.
279. STEMPELL, W. Ueber Organismenstrahlung. *Strahlentherapie* **40**: 777-779. 1931. (*See also Arch. Exp. Zellforsch.* **11**: 38-41. 1931.)
280. STEMPELL, W. Die unsichtbare Strahlung der Lebewesen. 108 p. Gustav Fischer; Jena, 1932.
281. STEMPELL, W. Die unsichtbaren Organismenstrahlen. *Med. Klin.* **1**: 456-457. 1933.
282. STEMPELL, W. Ueber die Fernwirkung der organischen Organismen auf die Liesegang'schen Ringe. *Riv. Biol.* **1**: 67-77. 1933.
283. STEMPELL, W., and G. VON ROMBERG. Ueber Organismenstrahlung und Organismengasung. *Protoplasma* **13**: 28-235. 1931.
284. STEMPELL, W., and G. VON ROMBERG. Weitere Versuche über die Wirkung der Organismenstrahlung und Gasung besonders derjenigen des Karzinoms und des ermüdeten Muskels auf die Liesegang'schen Ringe. *Biol. Zentralbl.* **52**: 413-420. 1932.
285. STEMPELL, W., and G. VON ROMBERG. Anurenkeime als Detektoren für Organismenstrahlen und die Wirkung ultravioletter Strahlen auf die Anurenentwicklung. *Naturwiss.* **67**: 19-36. 1932.
286. STEMPELL, W., and G. VON ROMBERG. Weitere Untersuchungen über die Wirkung der Organismenstrahlen auf Froschkeime. *Protoplasma* **20**: 195-202. 1933.
287. STRELIN, G. S. The influence of mitogenetic rays (induced by yeasts) on germination of *R. nigricans* and on multiplication of *N. fulvescens*. *Ann. Roentgenol. Radiol. [Leningrad]* **7**: 191-197. 1929.

288. SULMANN, F. Variationen bei Bakterien. 1. Experimentelle Versuche zur Steigerung der BCG-Virulenz durch Dissoziation auf Eiernährböden und durch mitogenetische Bestrahlung. *Zeitsch. Immun. Forsch.* **81**: 1-31. 1933.
289. SUSSMANOWITSCH, HELÈNE. Erschöpfung durch mitogenetische Induktion. *Roux' Arch. Entwicklunsmech. Organ.* **113**: 753-758. 1928.
290. TAYLOR, G. W., and E. N. HARVEY. The theory of mitogenetic radiation. *Biolog. Bull.* **61**: 280-293. 1931.
291. TOKIN, B. P. Ueber die mitogenetischen Strahlen und die Liesegang'schen Ringe. *Biol. Zentralbl.* **50**: 641-671. 1930. (*See also Arch. Exp. Zellforsch.* **11**: 42. 1931.)
292. TUTHILL, JOHN B., and OTTO RAHN. Zum Nachweis mitogenetischer Strahlung durch Hefesprossung. *Arch. Mikrobiol.* **4**: 565-571. 1933.
293. UFBAND, J. Die mitogenetische Strahlung der Nervenzentren. *Fiziol. Zeitsch.* **16**: 501-504. 1933.
294. URBANOWICZ, KASIMIERA. Gurwitsch's mitogenetische Strahlung an Paramacienteilungen geprüft. *Roux' Arch. Entwicklunsmech. Organ.* **110**: 417-426. 1927.
295. VACCA, ADRIANO. Ulteriori studi sulle radiazioni "mitogenetiche." II. *Publ. Staz. Biol. San Bartolomeo [Cagliari]* No. 26. 1931.
296. VACCARI, ADRIANO. Ricerche sulle radiazioni mitogenetiche. *Arch. Fisiol.* **30**: 350-365. 1932.
297. VANZETTI, G., and C. MAXIA. Reazioni chimiche e produzione de radiazioni fisiche. *Atti Soc. Cult. Sci. Med. e Nat.* **29**: 1931.
298. VANZETTI, G., and C. MAXIA. Ulteriori studi sulle radiazioni "mitogenetiche." IV. *Publ. Staz. Biol. San Bartolmeo [Cagliari]*. No. 28. 1931.
299. VEIL, S., and L. BULL. Étude cinétique des anneaux de Liesegang. *Compt. Rend. Acad. Sci. [Paris]* **192**: 682-683. 1931.
300. VEIL, S., and L. BULL. Étude microscopique et cinématographique des anneaux de Liesegang. *Compt. Rend. Acad. Sci. [Paris]* **192**: 282-284. 1931.
301. VIALE, GAETANO. I raggi mitogenetici. *Rassegna Med.* **1** (No. 1): 1-12. 1932.
302. WAGNER, N. Ueber den von A. Gurwitsch entdeckten spezifischen Erreger der Zellteilung. *Biol. Zentralbl.* **47**: 670-678. 1927.
303. WAGNER, N. Ueber die Mitosenverteilung im Meristem der Wurzelspitzen. *Planta, Arch. Wiss. Bot.* **10**: 1-27. 1930. (*See also Ibid.* **5**: 70. 1929.)
304. WASSERMANN, F. Ueber Zellteilungshemmung durch Wärme und die Wirkung mitogenetischer Strahlen nach solcher Teilungshemmung. *Arch. Exp. Zellforsch.* **2**: 43-51. 1930. (*See also Klin. Wochensch.* **1**: 433-435. 1930.)
305. WASSILIEW, L. L., G. M. FRANK, and E. E. GOLDENBERG. Versuche über die mitogenetische Strahlung der Nerven. *Biol. Zentralbl.* **51**: 225-231. 1931.
306. WOLFF, L. K. and G. RAS. Ueber Gurwitsch-Strahlen bei Bakterien. *Acta. Néerl. Physiol.* **1**: 136-137. 1931.
307. WOLFF, L. K. and G. RAS. Eenige onderzoekingen over demitogenetische stralen van Gurwitsch. *Nederl. Tydsch. Hyg. Microbiol. en Serol.* **4**: 265-280. 1932.
308. WOLFF, L. K. and G. RAS. Ueber Gurwitschstrahlen bei einfachen chemischen Reaktionen. *Biochem. Zeitsch.* **250**: 305-307. 1932. (*See also Ibid.* **259**: 212. 1933.)
309. WOLFF, L. K. and G. RAS. Ueber mitogenetische Strahlen. V. Ueber die Methodik zum Nachweis von Gurwitschstrahlen. *Centrabl. Bakt. Paras. und Infek. Abt. 1.* **128**: 314-319. 1933. (*See also Ibid.* **123**: 259-271. 1932; **128**: 305-313. 1933.)
310. WOLFF, L. K., and G. RAS. Effect of mitogenetic rays on eggs of *Drosophila melanogaster*. *Nature* **133**: 499. 1934.

311. YPSILANTI, H. P., and R. PALTAUF. Zur Frage des Nachweises von Wachstumsstrahlen in malignen tierischen Tumoren. *Zeitsch. Krebsforsch.* **32**: 372-376. 1930.
312. ZAKRZEWSKI, Z. Ueber die Wirkung der Gurwitsch-Strahlung auf Gewebekulturen in vitro. *Arch. Exp. Zellforsch.* **14**: 471-478. 1933.
313. ZEHNDER, L. Zur Untersuchung ultravioletter Strahlung. *Zeitsch. Phys.* **80**: 699-700. 1933.
314. ZIRPOLO, G. Le radiazioni mitogenetiche di Gurwitsch. *Riv. Fis. Nat. e Sci. Nat. [Naples]* **4**: 134-138. 1929. (*See also Ibid.* **6**: 8-16. 1931.)
315. ZIRPOLO, G. Ricerche sulle radiazioni mitogenetiche. *Boll. Soc. Nat. Napoli.* **42**: 169-208. 1930.
316. ZIRPOLO, G. De radiationibus mitogeneticis et de "Effetto Stempell." *Pont. Acad. Scient. Nov. Lync.* **2**: 9-10. 1932.
317. ZOGLINA, I. Le spectre mitogénétique physiologique des fibres motrices de sciatique. *Ann. Physiol. e Physiochem. Biol.* **10**: 134-136. 1934.

Manuscript received by the editor June, 1934.

XXIX

EFFECTS OF X-RAYS UPON GREEN PLANTS

EDNA L. JOHNSON

Department of Biology, University of Colorado

Introduction. Physiological effects of X-radiation: Effect upon seed germination and early growth—Effect on root development—Condition affecting ray-sensitivity of plants—Effect on respiration—Effect upon plant movements—Summary. Morphological and histological effects of X-radiation: Morphological effects upon leaves, aerial stems, and underground stems—Morphological effects upon flower and fruit development—Histological effects—Summary. Cytological effects of X-radiation. General summary. References.

INTRODUCTION

Since the discovery of X-rays by Röntgen in 1895, the majority of published papers dealing with the influence of these rays on plant life have considered their general effects on physiological processes including rate of seed germination and growth, respiration, and movements. The morphological and cytological aspects have attracted a considerable number of investigators, while relatively few workers have been interested in the histology of rayed tissues.

The use of different units of measurement by the various investigators has increased the difficulty of a comparative study of the results obtained with X-rays upon plant and animal tissues. Many of the German and French writers have used the Holzknacht (H) which is approximately the equivalent of one-fifth skin-erythema dose. The erythema is largely used by medical men and by some research workers; authorities differ as to the exact definition. It is that amount of X-rays which will produce a distinct reddening of the human skin at the end of a development period, usually 10 days following the exposure. The erythema dose is the equivalent of 5 H units. Unfortunately, the erythema is difficult to determine accurately, owing to individual and racial differences. It has been abandoned by the research worker for a new arbitrary international unit (see Taylor, Paper II, p. 68) called the "roentgen," designated by the small letter r. Dosimeters have been designed which accurately measure the X-ray output in r-units, 300 to 600 r-units constituting an erythema dose.

Many investigators, irrespective of the unit of measurement employed, have given the "set-up" of the machine, recording the voltage, amperage, distance from target to area irradiated, time, and statement as to whether

rays were filtered or not. Whenever the dosage is not given in r-units, the set-up of the machine should be given.

The discussion which follows will present a critical review of the studies which have been made on the effects of X-rays upon green plants.

PHYSIOLOGICAL EFFECTS OF X-RADIATION

Many of the earlier studies of the effects of X-rays upon green plants center around the question of their influence upon the processes of germination and seedling growth. Often conclusions have been based on a few experiments involving a limited number of seeds without the utilization of enough check plants grown under similar environmental conditions. Other conclusions were drawn from short-time experiments in which the investigators did not allow the plants to grow to maturity, hence they have not been able to judge how irradiation affects the entire life cycle of the plant. There is agreement that in general the effect of X-rays upon living material is destructive. Medium to heavy doses cause a depressing action on growth. Contradictory results, however, are reported by those using light doses. Many report a stimulative action while others believe that, if there is an apparent hastened growth, it is but an acceleration following a retardation which occurs immediately after exposure.

Some of the conflicting results published by those who have worked with light doses may be due to different interpretations of the term "stimulation." It is assumed in this paper that the investigators have used the term in its more popular sense to indicate a positive reaction unless a definite statement is made to the contrary. A report that light doses "stimulate" growth is interpreted to mean that there is increased growth, which results in greater dry weight. A more technical meaning of the term indicates merely the response to a stimulus, whether positive or negative. In this sense, any response of the plant shown by either increased or decreased growth would be considered a stimulation. The use of the word to indicate quickened growth is much more general than the use in the latter sense.

The writer (19) has found that, when medium doses of X-radiation are used, a depressing effect proportional to the doses, within certain limits, is evident during the first few weeks of growth. Later the growth inhibition disappears and for a time the irradiated plants may actually show faster growth, until at maturity there is little difference in total height between controls and treated plants. Some of the earlier workers noted the growth-checking tendency and regarded the later acceleration as a natural consequence similar to that which occurs in plants after mild injury. Others, however, using a small number of plants and taking measurements during the time of growth acceleration, have recorded the results as stimulation due to the action of the rays.

Evidence from experimental work reviewed in this paper indicates that a majority of those who have made repeated experiments using large numbers of seeds have found that light doses do not cause increased germination or increased growth in vegetative parts.

EFFECT UPON SEED GERMINATION AND EARLY GROWTH

Historical Account of Work up to 1924.—Three years after Röntgen discovered the X-rays, Maldiney and Thouvenin (40) published a statement to the effect that X-rays hastened the germination of seeds of *Convolvulus* and *Lepidium*. Ancel (2), who criticized these studies because of the small number of seeds used, employed hundreds of seeds of the same species and found that in no case was germination of the seeds hastened by irradiation.

Koernicke (26), in 1904, using two species of *Vicia* and *Brassica*, referred to growth checking followed by a growth acceleration which was transitory if the dose were not too strong. In a later research (27), using many species of plants to test the practical use of roentgen irradiation in agriculture, he concluded that X-rays parallel other rays in showing growth retardation with stronger doses but growth stimulation with weaker ones. He also found that with air-dried seeds germination of those strongly irradiated occurred sooner than with those weakly irradiated and sooner than the controls. Ancel (2), who repeated the experiment with *Brassica napus*, using 16 lots of 100 seeds each, found that radiation applied on the dry seeds in doses varying from 0.5 to 20 H did not hasten germination.

Miege and Coupe (41) reported stimulation of growth in *Raphanus* and *Lepidium* which manifested itself in increased weight of leaves of irradiated plants as well as by increase in total weight. Daily doses of 2.5 H were found to cause greatest acceleration. These positive statements of results are open to criticism because they were based on groups of 10 seeds in each experiment. Later investigators have shown that only by using large numbers of seeds and by repeating the experiments several times can one avoid misinterpreting results.

Pfeiffer and Simmermacher (49) claimed that the germination of *Vicia Faba* was increased by short exposures to X-rays but lessened by long exposures. E. Schwarz (57) also found accelerated growth in *V. Faba* with the use of weak irradiation. His work has been criticized by Komuro (30) for the smaller number of experiments and for the lack of controlled conditions under which the experiments were conducted. Jüngling (23), using the same species, found that the effect of raying the seeds or seedlings can be either stimulating or depressing. He used an erythema dose, designated by Seitz and Wintz as the "Hauteinheitsdosis" (H.E.D.). When a light dose of 5 to 6 H.E.D. was given, root growth was unaffected while shoot growth was increased. Halberstaedter

and Simons (15) also working with *V. Faba* concluded that light doses up to 5 H.E.D. cause stimulation, but above that retardation of growth occurs. Their results indicate that a less sensitive plant, *i.e.*, one which is little affected by the rays, requires a greater dose for either retardation or stimulation than a more sensitive one. Wheat, which is less ray-sensitive than *V. Faba*, showed transitory stimulation with doses up to 200 H.E.D. These investigators conclude that the dose necessary to cause stimulation is in an inverse ratio to the ray sensitivity of the cells.

Altmann, Rochlin, and Gleichgewicht (1) observed that irradiation of the bean, *Phaseolus vulgaris*, resulted in a transitory acceleration of development. They report that the stimulation dose varies with the stage of development, the dose for the dry bean lying between 6 and 12 H; for the two-day seedling, between 1 and 3 H. When Ancel (2) repeated this experiment, however, it was found that the control lots showed as great a variation among themselves as did the control and irradiated groups. If Altmann, Rochlin, and Gleichgewicht had increased their control lots, doubtless they would have obtained among them differences as great as they observed between the control and irradiated plants. Ancel (4) concluded from her experiments in which she used large numbers of control and irradiated beans, lentils, and wheat, that the so-called accelerating action of weak doses of X-rays on the development of plants does not exist. The chief cause of error made by some of these earlier experimenters is that they have not taken into consideration the individual variation of the seedlings.

Komuro (29a) repeated the experiments of Yamada and Nakamura who had obtained an increased yield of rice from weakly irradiated seeds. He reported that the number of tillers in plants from soaked seeds decreased proportionally to the dose given, that no positive stimulation was apparent, and that the crop was not increased by irradiation. This same investigator (29b), in a second experiment conducted two years later, concluded from his study of two pure lines of *Oryza sativa* that acceleration of germination is obviously shown in seeds X-rayed in the air-dried condition and that a dose of 5 to 10 H seemed to be the optimum. An analysis of the data, however, shows that in half of the experiments only 4 to 20 seeds were used in each lot. Very slight acceleration or none at all was evident in the majority of the remaining experiments in which 100 seeds were used. Komuro concluded that early growth from irradiated soaked seeds was better than from controls, but his figures show very slight differences between the average lengths of each lot. In testing the influence of radiation on processes showing as much variation as do germination and growth, a large number of seeds should be used and differences between average measurements in each group should be sufficiently great because of the individual differences which occur even between members of groups subjected to the same environ-

mental conditions. If Komuro in his second group of experiments had used more seeds and grown his plants to maturity, he would doubtless have confirmed the results of his former experiment. Because of his conclusion that the germination of air-dried seeds, which were steeped in water 29 hr. after irradiation, was obviously accelerated, Komuro believed that the practical application of roentgen rays in agriculture would be possible and profitable if air-dried seeds were X-rayed and sent to other places for sowing in the rice fields. Ancel (2a), on the contrary, found with wheat and lentils that there was no increase in percentage of germination with irradiation and that delay in placing the irradiated seeds under proper conditions for germination caused fewer seeds to develop.

Geller (10), after examining results of experiments covering the period 1910 to 1923, concluded that small doses of X-rays cause acceleration of development while large ones produce a depressing action. The effect depends on the species and condition of the plant, for some are more affected than others and all are more ray-sensitive when growth is active. Geller believed that there was no absolute ray dose for retarding or stimulating plant growth since the effect is dependent on so many factors. At the present time, the problem of possible stimulation is still unsolved. Some investigators believe that they have demonstrated stimulative effects with weak doses while other careful experimenters have demonstrated either no effect or one which is harmful to the plant.

Papers Published since 1924 on Stimulation and Retardation.—Brief mention will be made of the investigations of others working since 1924 who claim to have demonstrated a stimulative or accelerative influence of X-radiation upon growth. Arntzen and Krebs (6), using peas, found that with light doses a stimulative effect could be demonstrated for the first and, in some cases, for the second 24-hr. period after exposure. This was followed by retarded growth.

Iven (17) has seemed to confuse the acceleration following a retardation in growth of *Vicia Faba* seedlings with true stimulation. In the earlier part of his paper, he states that his results agree with those of E. Schwarz, Koernicke, and Halberstaedter and Simons who considered weak doses as stimulative. Later, he refers to growth-acceleration phenomena which appear within 10 to 20 days after treatment, after which growth again becomes normal. The stimulating effect with minimum doses, Iven concludes, is a passing one. From these statements, it would seem that Iven is referring to an acceleration of growth following a retardation, which is commonly reported after radiation, rather than to true stimulation resulting in increased growth. He found that germination of seeds was not hastened by the rays.

Rivera (53) considered increased development of aerial buds following irradiation as a stimulation. He reported also that roots seem to derive

an indirect benefit from irradiation, as they show extraordinary elongation. In view of the fact that no other worker has reported increase of root growth with radiation, Rivera's conclusions need confirmation before being accepted.

Goodspeed and Olsen (14) stated that a marked acceleration of growth and development may follow appropriate X-ray treatments and Goodspeed (13) reported that on three occasions pot-grown plants of *Nicotiana rustica pumila* irradiated just previous to first flowering had shown an immediate and very marked growth acceleration. The studies of these authors, however, were concerned principally with the cytological effects of radiation, hence the authors have not published complete data on growth which support the conclusions drawn.

Stimulative effects of the rays have been claimed by Jacobson (18) who reported that by irradiation the crop of one variety of potatoes was increased 84 per cent in weight over the control plants, while with another variety the increase was as much as 200 per cent. He stated that each tuber was larger than normal and that there was also an increase in total number of tubers. Johnson (22a) in a series of experiments extending over five growing seasons and involving the growth of 17,000 tubers, found that irradiating the unsprouted tubers of the Colorado wild potato (*Solanum Jamesii*) with a dose of 1500 r-units caused a slightly greater production than from controls. Using the same dose on sprouted tubers caused an increase of over 40 per cent in the average number of tubers per hill with an even greater increase in the average weight per hill. The individual tubers from the treated plants also weighed more than did those from check plants. The conclusion drawn is that increase of rhizome development in the wild potato, which causes formation of a greater number of tubers, is similar to the increased aerial branching which occurs in some other members of this family when the very young plants are treated with medium doses. Sprague and Lenz (62) in a preliminary experiment find results which indicate that strong doses may reduce the number of tubers formed. Such tubers may attain a greater size so that yields of marketable stock are not lowered. In no case, however, did they find the crop increased.

Shull and Mitchell (60) in a recent publication report preliminary experiments with very light doses of filtered X-rays which lead them to conclude that stimulative effects may be consistently obtained if appropriate conditions are employed. They believe that harmful effects mask stimulation which occurs when the beam is properly filtered. Very small doses of 30 to 120 r-units were used on seedlings of wheat, corn, oats, and sunflower. The treated individuals of the wheat plants were reported taller, of ranker growth, and exhibiting a higher degree of tillering. Corn rayed 1 to 5 min. showed a higher percentage of germination than the controls, a greater fresh and dry weight of coleoptile, and

increased chlorophyll content. A group of sunflower plants rayed 3 min. blossomed before the controls, indicating a shortening of life history by the treatment. The conditions which the authors believe necessary for such stimulative action are: the use of metallic screens, high voltage and low amperage, and brief exposures. The total dosage for stimulation does not much exceed 100 r-units. Even with the 1-mm. aluminum screen, sunflowers given 150 to 200 r-units were overtreated. Optimum growth occurred with about 115 r-units (3 min.).

Investigations will now be given in which there has been found no case of stimulation but always definite retardation. Capizzaro (8) writes of temporary retardation of development occurring in proportion to the time of irradiation and the quality of rays produced. Maisin and Masy (39) obtained marked inhibition of growth when seeds of *Pisum sativum* were exposed to X-rays. No lethal effects occurred with the dosage employed. Glocker, Hayer, and Jüngling (11) found retardation in growth of bean seedlings, particularly with softer rays (those produced with lower voltage).

Johnson (20a) irradiated numerous seedlings of tomato, sunberry, sunflower, and two species of vetch with light X-ray doses which have been reported to cause stimulation. After the plants had grown for periods of sufficient length for the detection of any stimulative action, comparisons were made of green and dry weights of experimental and control plants. In two groups, root growth was considered as well as growth of tops, and in two groups stem height was also considered. In all cases studied a considerable number of treated plants with a like number of controls were grown under the same environmental conditions. No increased growth of experimental plants over the controls was evidenced by measurements either of height or of green- and dry-weight determinations.

Horlacher and Killough (16) found that X-rays produced a differential growth rate in cotton seedlings. When a few days old, the rayed seedlings could be divided into three classes: normal, intermediate, and dwarf.

Schwarz, Czepa, and Schindler (58), working with wheat, horse bean, and lentil, found no stimulation with weak doses. In their experiments with wheat, 20 seedlings were used in each of 12 groups and lots were exposed for 5, 10, 20, 30, and 45 sec., and for 1, 3, 5, 10, 20, 40, and 50 min., respectively. Nine groups of controls were measured. The authors found that seedling length increased when the time of irradiation was 5 min. or less, after which it decreased. But when the controls were measured, it was found that the highest value for the control was 1 mm. higher than the greatest measurement for the irradiated. Essentially the same results were obtained with the horse bean and lentil. Their conclusions agree with those of Ancel (4) who, from numerous

experiments involving thousands of seeds, concluded that weak doses did not cause acceleration of growth. When large numbers of irradiated plants and controls were used, the plants irradiated with weak dosage behaved like controls.

Bersa (7) has pointed out that because of the markedly variable material used in studying the biological effects of X-rays, statistical methods are especially necessary. Bersa believes with others quoted that a dose causing genuine roentgen stimulus for seedlings cannot be given as yet.

Taken as a whole, conclusions from the numerous experiments on the effect of X-radiation on seed germination and early growth of seedlings indicate that medium and heavy doses are injurious. Some investigators believe that they have demonstrated the stimulative effects of light doses, while others have found only retardation or lack of change. It appears that many who have reported stimulation with X-rays have not taken into account the variability of individual plants. The majority of those who have used large numbers of seedlings and have repeated their experiments many times agree that weak doses, which some have regarded as stimulative, do not regularly cause increased germination of seeds or increase of vegetative parts which results in greater dry weight.

EFFECT ON ROOT DEVELOPMENT

In 1920, Jüngling (23) reported a retardation in the development of lateral roots as a direct effect of radiating seedlings. Nakagawa (44) also found that medium to strong irradiation of *Vicia* seedlings disturbed the development and growth of root tips. Root hairs and rootlets did not form and the tissues of the root took on a permanent aspect. Microscopic examination showed the greatest changes in endodermis and dermatogen. According to Patten and Wigoder (47), roots of *V. Faba* were not only stunted by medium doses of irradiation, but they became slightly bulbous at the tip. Lateral roots never developed in the stunted X-rayed specimens. Roots of barley, Patten and Wigoder report, seemed little affected by the rays. Since others (63) have found the barley plant very ray-susceptible, this point should be investigated.

Ancl (3), using 30 to 60 seeds in each culture, recorded, after a certain exposure, the mean length of main root, rootlets, stem, and total length of the rootlets. Rootlets which showed the greatest growth depression seemed to afford the best test of the biological effects of radiation.

Cattell (9), who based results on 200,000 measurements of control and irradiated wheat seedlings taken 48 hr. after irradiation, showed that each of the 4 growing parts was affected to a different degree by the same dose. If one takes the relative percentage reduction of the coleoptile (with reference to the growth of the control) as 1, and compares it

with the other growing parts, the relative effect on the leaf is 6, primary root 16, and lateral roots 18. The lateral roots are then, according to Cattell, 18 times as ray-sensitive as the coleoptile.

Fibrous roots developed from treated seedlings of *Thunbergia alata*, maize, and castor-bean plant were found by Johnson (22a) to show markedly less growth in length of main roots, and particularly less growth in number and length of lateral roots. The main root of maize showed 48 per cent less growth in length of root eight days after receiving a dose of 2000 r-units. Main roots of castor bean, *Ricinus communis*, proved equally ray-susceptible. In both species there was entire suppression of lateral roots for several days after irradiation. Tap roots and roots developing from bulbs also showed serious injury from treatment with medium doses. Tap roots of radish irradiated in the seedling stage were shorter than in the control; in the former there was also a noticeable relative decrease in number and length of lateral roots. Raying the root end of narcissus bulbs with 3500 r-units caused a necrosis and marked stunting of roots. Three weeks after treatment, the experimental plants showed 52 per cent relative decrease in number of roots.

The age of the seedling and the hour of the day when the root tips are most sensitive have been the subject of some study. Seedlings of *V. Faba* 48 to 72 hr. old appeared to be the most sensitive, according to Patten and Wigoder (47). Ancel (2c) found that the sensitivity of root seedlings to X-rays continues to increase from the appearance of the embryo until the root has attained a length of about 1 cm., and thereafter it decreases.

Reinhardt and Tucker (51, 51a) have reported that roentgen irradiation during the night is more harmful to the growing seedlings of *V. Faba* than day treatment. Different groups of seedlings were treated each hour for 24 hr. These, with an equal number of controls, were placed under the same conditions of temperature, moisture, and light. Measurements at the end of two weeks showed that there had been the greatest retardation of growth and the greatest reduction in number of side roots in those which were irradiated from 9 to 10 A.M. and from 10 to 11 P.M. There is general agreement that cells in the process of division are affected more than resting cells by the same dose of radiation. In view of the fact that Kellicott (25) has reported that the periods of the greatest cell division in onion tips are at 1 P.M. and 11 P.M., it seems reasonable that irradiation given the growing points of seedlings just before these periods would cause an interference with the normal mitoses. Jüngling and Langendorff (24), however, have reported that the maximum number of mitoses in unrayed root tips occurs during the day. Investigators of the cytological effects of X-radiation might well investigate in other species the problem of the time of day when the growing points of seedlings are most sensitive to radiation.

CONDITIONS AFFECTING RAY-SENSITIVITY OF PLANTS

Plants on the whole are much more resistant to X-rays than are animals or human beings. Some species show a natural resistance to radiation while others are easily affected. Komuro (28, 30), using a heavy dose of 155 H on *V. Faba* seeds before planting them in the soil, found that although shoots did not appear above the ground, they developed to a certain extent. He believed it very probable that strongly irradiated seeds are particularly affected in the plumule and radicle; the metabolism of these parts may be so gradually modified that at a certain stage the seedlings may cease to develop at all. Johnson (19) found that irradiation of soaked sunflower seeds with a very heavy dose (30 E.) did not kill the embryos, but that the seedlings died soon after the cotyledons appeared above the soil.

Russ (55) as early as 1919 declared that the effects of radiation are selective; a dose which will destroy one type of cell may be without effect upon cells of a different variety.

Jüngling (23), a year later, called attention to the fact that sensitivity to radiation varies with different species of plants and that sensitivity depends on the condition of development. Koernicke (27), in 1915, wrote that roentgen culture would not be of practical value in agriculture because of variations in effect among different species of plants as well as variations among individual seeds in the same species. Others (20, 22, 23, 27, 35) also have noted that not only do different species react differently to the same dose, but members of the same species react differently according to individual variation of the seeds and to the stage of development.

Goodspeed (12) found no dosage which would prevent germination and growth of tobacco. Seeds exposed continuously for 3 hr. to 50 kv. and 5 ma. at a distance of 20 cm. without filters gave, at the end of three weeks, a total germination of over 95 per cent. The initial rate of germination, however, was retarded. This was mainly a transient effect, however, and so far as size and vigor at maturity were concerned, no general effects of X-radiation could be seen. Goodspeed found that the mortality after treatment of seeds which have just broken the seed coat was very high, and that the plants which survived were usually abnormal throughout or obviously reflected a mosaic of nuclear elements within. When germinating seeds or seedlings of tobacco in the cotyledonous stage were radiated, there was no difficulty in producing lethal effects. Those plants which survived exhibited a permanent as well as a transient distinction in growth and form.

Iven (17), who delayed planting irradiated seeds for eight months, found that the same effects were manifest as in those which were sowed immediately. Ancel (2a), on the contrary, found that allowing time

to elapse between irradiation and germination lowered the percentage of germination.

Many investigators (1, 13, 15, 17, 20, 26, 30, 68) have noted the increased susceptibility of seeds to X-rays when they have been soaked or have started to germinate. Stadler (63) claims that dormant barley seeds will withstand 15 to 20 times as heavy doses as germinating seeds. Water absorption by both seeds and seedlings tends to increase susceptibility to X-rays, according to Petry (48).

Russ (55) states that a single large dose of X-rays has a greater effect than the same amount of radiation given by repeated small doses. He believes that the process of repair can more easily cope with feeble radiation acting for a long time than with intense radiation acting for a short time. Arntzen and Krebs (6) find that a single full exposure produces a stronger biological effect on peas than the same dose administered in a series of "divided doses."

Lessening the effect of subsequent doses by giving a preceding lighter one is called "radiophylaxis" by Ancel and Lallemand (5) and Lallemand (35, 36). A light dose followed by a medium one was found to produce less injury to root tips of bean than the application of one dose of medium intensity. These investigators, after eight repetitions of experiments involving 40 seeds each, concluded that the cell reaction to the first dose had rendered it less sensitive to the action of doses subsequently given. An interrupted dose had less effect than the same dose given all at one time, owing to the existence of a radiophylactic reaction.

Effects of radiation are thought by some to be influenced to a certain extent by temperature. Wernhart (68) states that the reaction of the plant varies with the temperature and humidity. Promsy and Drevon (50) find that with moderately high temperature irradiation favors germination and accelerates the development of plants. Less harm is manifested in irradiated material when germination takes place at 20° to 25°C. than when at 10° to 14°C., according to Ancel (2b).

Weber (66) reports that forcing resting buds of *Syringa vulgaris* may be accomplished by using doses ranging from 26 to 150 H. The former dose will cause forcing after a resting period. The use of higher doses will produce a necrosis in the basal region of the bud causing the bud scales to fall. Reiss (52) agrees with Weber (66) that *Syringa* buds are forced if the irradiation is not too strong. Shoots are injured if the dose is beyond the optimum. In view of the controversy concerning the stimulatory effects of X-rays, studies of this nature should be repeated and the exact dosages determined which produce the so-called stimulation.

A review of the conditions affecting the ray-sensitivity of plants indicates that there is considerable resistance to the rays, for even when very heavy doses are given seeds, the embryo develops to some extent. Not only is there variation among different species of plants, but members

of the same species react in a different manner according to the individual differences in the seeds and to the stage of development. Soaked or germinating seeds are more susceptible to the rays than dormant ones. Series of lighter doses seem to have less biological effect than has the same dose given all at one time. More investigations on the influence of temperature on the effects of radiation and on the alleged forcing of buds by the rays are needed before definite conclusions can be drawn.

EFFECT ON RESPIRATION

Preliminary experiments by Shull and Mitchell (60) indicate that very weak doses cause increased respiration in rayed seedlings. Bersa (7b) and Johnson (19) have both found reduction in respiration when medium to heavy doses were given. Bersa found that in excised root tips given a dose of 5 H, $\frac{1}{2}$ to 1 hr. after irradiation, there occurred a transitory, weak acceleration due to a temporary, traumatic effect of the stimulus; 6 hr. after irradiation, however, the respiratory rate was lower than that of the controls. Johnson found that depressed respiration accompanies inhibited growth of the sunflower resulting from heavy irradiation.

EFFECT ON PLANT MOVEMENTS

Küster (34) has given information concerning the effects of radiation on the nyctinastic and seismonastic movements in the bean and in *Mimosa*. His results are contradictory to those of Seckt (59) who found that radiation caused a folding of the leaflets of *Mimosa* and *Oxalis*. Küster, in numerous carefully controlled experiments, produced permanent paralysis in both *Phaseolus vulgaris* and *Mimosa* by exposing the bases of the petioles and bases of petiolules to the rays. The leaves were paralyzed only to the extent that the rays had touched them. The action of the pulvinus at the base of the leaflets was not influenced by the paralysis at the base of the leaf. This may be shown by the fact that the stream of sap which flows through the paralyzed pulvinus continues up to the leaflet. Hard rays were found to be more effective in producing paralysis than soft ones. No difference was found in the plant response when exposures were made at different hours; those exposed in the early morning responded similarly to those exposed at noon or in the afternoon. Aside from paralysis, the plant was uninjured; blossoming and fruiting occurred normally.

SUMMARY

The evidence presented in the papers dealing with the physiological effects of X-rays indicates the injurious effects of medium and heavy doses. The problem of the so-called stimulative action of light doses,

which has been a subject of controversy for 35 years, still remains to be solved. Some investigators believe that they have shown stimulative effects of light doses, while others have referred only to a transitory acceleration of development. The majority of the later workers, however, have found that with carefully controlled experiments carried on to maturity, with records taken at the end of the life cycle, doses regarded as stimulative do not regularly cause growth increment in vegetative parts. With comparable units of measurement available in the use of the r-units, within a few years there will undoubtedly be agreement concerning the effects of light doses. The experimental evidence to date seems to indicate that stems are less sensitive to the action of the rays than roots; lateral roots are much more susceptible than the main ones. Dry seeds are particularly resistant to the rays; even extremely heavy doses do not prevent the cotyledons from appearing. The effects are materially influenced by the stage of development; seedlings are much more sensitive than dry seeds. Respiration of rayed seedlings parallels growth, that is, if growth is retarded, respiration is likewise. Nyctinastic and seismonastic movements are reported to be inhibited by rays of sufficient intensity.

MORPHOLOGICAL AND HISTOLOGICAL EFFECTS OF X-RADIATION

MORPHOLOGICAL EFFECTS ON LEAVES, AERIAL AND UNDERGROUND STEMS

Morphological and histological effects accompanying X-raying have been almost universally noted in leaves, stems, and flowers by those who have grown plants to maturity. The destructive action of medium and heavy doses is marked in many species. X-rays seem to kill certain cells and leave others free to proliferate. Deformed organs and unusual branching then result.

Johnson (19, 20a, 22, 22a) found almost universal production of leaf anomalies unless the species irradiated was extremely ray-resistant. Unfolding leaves from seeds or seedlings irradiated with medium or heavy doses presented a peculiar pebbly appearance soon after treatment. As the leaves grew older, light-green areas intermingled with normal green gave a mosaic or variegated aspect. The early leaves seldom showed complete recovery, but those produced later by these same plants appeared normal in all respects. Anomalies in shape were frequent. Simple leaves were often notched at the apex, deeply forked, or occasionally split into two independent leaves, attached at the same point on the main stem. Many of the leaves in the growing tip showed incurling and ruffling of the margins. In a compound leaf such as the tomato, leaflets were often twisted for one-half to one-third of their length; in many cases, for half the length of the leaflet, the blade on one side was absent. Fusion of leaf parts was common and occasionally the widened base of the leaflet

fused with the main rachis so that no petiole was present or the tip edge of the leaflet was attached to form cuplike structures.

Rivera (53) found that irradiation of the castor bean caused retardation in the development of the shoot. Subsequent growth showed poorly developed leaves with very irregular margins.

Sprague and Lenz (62), who irradiated sprouted potato tubers, noted the peculiar shape of the first leaves. The tips appeared injured and the blade seemed to be pinched in. Leaf margins curled downward and the leaf in general appeared more glossy than normal leaves. Later the leaves became normal.

Navashin (46) found that seedlings from soaked seeds of *Crepis tectorum* showed marked influence of X-rays as early as six days after germination. Delayed and abnormal development of the first leaves seemed clearly connected with the dosage employed. Johnson (20) found that the cotyledons were little affected by radiation. However, irregularities in number and size of cotyledons as well as anomalies in leaf shape were evident in cotton seedlings irradiated by Horlacher and Killough (16). Numerous irregularities in leaf color, including a sectorial chimera, were noted.

Development of axillary buds following irradiation was reported by Ancel (3a) who exposed growing tip cells to the rays but protected roots by a layer of leaded caoutchouc. Growth activity was transferred to the axillary buds.

Rivera (54) wrote of "buds of restitution" which follow the initial arrest of development. He reported the accelerated development as stimulation, and believed that he had found doses which stimulated development of the aerial parts as well as the roots.

Excessive branching of stems of irradiated seedlings and stem fasciation have been described by Johnson (19, 21) for species of *Helianthus* and *Lycopersicon*. In fact, many ray-susceptible plants showed this character after treatment. Stems showed fasciation three weeks after irradiation; they were generally cylindrical at the base, but the apex was diffusely branched. The stems after becoming flattened usually showed splittings somewhere along their lengths; the resulting branches sometimes remained unfasciated, but in many cases they themselves became divided again. Grooves appeared in portions of the stem. Dichotomous branching often occurred in the sunflower 50 to 90 cm. from the stem base; further splitting of the stem occurred with six or more tips becoming evident. The percentage of fasciated stems increased with an increase of dosage given to young seedlings.

Tomato plants receiving medium dosage of X-rays developed many lateral branches which caused them to assume a bushy appearance. Increase in branch development was found to be from 27 to 65 per cent greater in the irradiated plants than in the controls. Other plants which

showed excessive branching when the young seedlings were irradiated included: *Agrostemma*, *Dianthus*, *Viscaria*, *Gilia*, *Alonsa*, *Matthiola*, *Impatiens*, and *Linum*.

Greater development of axillary buds of underground stems was claimed by Morgan (43), who found on raying Freesia corms that those receiving lighter doses produced a greater number of plants per pot. While each control corm produced but a single plant, as many as five shoots were produced by a single X-rayed corm. Usually only the top bud developed while the others were aborted. Morgan believes that raying stimulates the growth of buds other than the apical one. With a heavy dose, retarding effects on growth were evident.

Seaglia and Businco (56) found that when hyacinth bulbs were irradiated with increasing dosages of X-rays, one or more examples out of every group showed a greater development than the controls. Johnson (22a), using 3500 r-units on paper-white narcissus bulbs, found that the number of shoots from the treated bulbs was approximately the same as in the controls, but that the former showed over 50 per cent decrease in height of the shoot. The average number of leaves per bulb was somewhat lower in the rayed specimens.

The tobacco plants studied by Goodspeed (12) which survived treatment were usually abnormal throughout. Differences in growth rate, habit, leaf form, and in fertility between treated and controls were evident. "A certain amount of this variation," Goodspeed and Olsen (14) believe, "is a consequence of disturbance of mitotic or meiotic elements or mechanisms, the results of which are visible, possibly cytoplasmic in origin and directly referable to the particular character of the treatment." In some cases, the normal appearance of the young plant may be the result of the replacement of an abnormal by a normal axis following the proliferation of an apparently unaffected, lateral bud. Goodspeed figures plants from X-rayed seedlings showing dwarf habit, abnormally narrow, lanceolate leaves with irregular and weak venation, often notched at the top or split for more than half the length. Variations in flower color, form, and fertility were also evident.

X-rayed barley seedlings do not produce anomalies conspicuous in most other plants, according to Stadler (63) who reported that in a careful examination of 23,000 treated plants he found only two variations affecting the tillers directly. In one plant, two of its tillers had distinct, broad, yellow stripes on the leaf blades and sheath; the other plant had a similar yellow stripe on the upper sheath and blade of the main stalk, beginning as a narrow line but broadening on the upper leaves and appearing on several spikelets of the head. The seeds of these spikelets gave yellow, green, and sectorially yellow-and-green plants. Stadler also reported the occurrence of mutant seedling characters, many of which were chlorophyll abnormalities.

Freesia plants produced from irradiated bulbs showed irregularities in the texture of the leaf, stem, and flower which Morgan (43) described as suggestive of "crepe cloth." Light and dark areas in stem and leaves indicated chlorophyll disturbances. Growth irregularities caused curling and twisting of leaves and stems and splitting and deformities of flowers.

MORPHOLOGICAL EFFECTS ON FLOWER AND FRUIT DEVELOPMENT

Moore and Haskins (42) have reported premature flowering of grapefruit plants from X-rayed seeds. Buds in two plants appeared two months after irradiation. A small but normal flower was produced by one, while the other was imperfectly pigmented. A repetition of this experiment with many controls and treated plants would be necessary before it could be definitely concluded that X-rays produce premature flowering. Genera in which Johnson (22a) has found retarded blossoming include the following: *Rhodanthe*, *Dianthus*, *Gilia*, *Nemesia*, *Statice*, *Schizanthus*, *Acroclinium*, *Helianthus*, and *Lycopersicon*.

Fasciation of the flower head of sunflower resulting from irradiation in the seedling stage has been reported by Johnson (19). Fusion sometimes took place in the involueral region, giving the appearance of twin heads, or occasionally there was forking of the stalk below the involucre, with two or three distinct heads resulting.

Abnormalities of floral parts, including production of double blossoms, were found (21) to occur in tomato plants which were irradiated three times previous to the blossoming period. If, however, irradiation was given at time of budding, when there had been no previous dose, the buds were abscised. Later growth might produce blossoms, some of which were normal while others were double or triple. Plants irradiated during their early seedling stages showed delayed fruit development. In plants irradiated with one medium dose just before blossoming, complete sterility was present for a time. Later the new growth produced small abnormal fruits on 25 per cent of the plants as compared with 100 per cent fruit production of the controls. Fruits which did develop on the irradiated plants had a lack of definite internal pattern. The placenta and core showed abnormal development and there was an almost total absence of seeds. Pockets formed in the pericarp of fruits from irradiated plants were not found in the controls.

Goodspeed (13) noted that in *Nicotiana Langsdorffii* all buds of the terminal inflorescence were abscised immediately after treatment and all the first flowers on the laterals were abnormal. Both abnormal and normal flowers set full capsules of seeds. He suggests that the relation of irradiation to the abscission reaction and factors controlling or modifying it should provide an interesting field for carefully controlled investigation.

McKay and Goodspeed (38), working with cotton, found that in fruits obtained from X-rayed pollen and untreated eggs there was a decrease in number of seeds per fruit as the dosage became heavier. Only 21 plants were produced from over 150 seeds, giving further evidence that sterility is a by-product of X-ray treatment. These same authors reported that striking morphological alterations were carried over to the next generation, for they were found in cotton plants produced by seed from plants derived from X-rayed pollen and untreated eggs. Some of these alterations were the presence of twisted and deformed stigmas, anastomosing leaf veins, peculiarities in leaf shape, fasciated and enlarged stems, incomplete flowers, and dwarfness in habit.

HISTOLOGICAL EFFECTS

The comparatively few writers who have investigated the histological changes which occur in tissues subjected to X-radiation have concluded that the stems of treated plants show an early maturity, as indicated by the advanced development of woody tissues.

Altmann, Rochlin, and Gleichgewicht (1), in making a microscopic examination of the irradiated stems of *Phaseolus vulgaris*, found a greater development of mechanical tissue than was present in the controls. The xylem was increased at the expense of the pith. Similar results were reported by Johnson (19) who found that an increase of xylem with a corresponding decrease of pith cells was apparent in the hypocotyl region of mature *Helianthus* plants grown from irradiated seeds. In cross sections from the hypocotyl regions of irradiated material, the pith cells were much smaller in diameter and were thicker walled than in control stems. The elements of the xylem in the former were much smaller in diameter and were arranged more compactly. Even in seedlings nine days old, a striking difference was shown in the amount and character of xylem. There was a much greater percentage of xylem in the irradiated specimens, with individual cells showing a similarity in size rather than the wide diversity in size of cells which is typical for xylem of young *Helianthus* stems. Miede and Coupe (41) likewise found the vascular tissue of *Raphanus* and *Lepidium* more developed in rayed plants.

Tissues of irradiated roots of *V. Faba* early took on a permanent aspect, according to Nakagawa (44). The greatest changes occurred in the growing point, including endodermis and dermatogen; the pterome suffered least.

Cross sections of leaves of tobacco plants from germinating seeds which were X-rayed exhibited various structural peculiarities, according to Goodspeed (12). Cell number, form, and arrangement were the same in treated and control plants, but increase in cell volumes in the treated material accounted for the abnormal leaf thickness. More

histological studies of X-rayed tissues should be made in order to better understand the real effects of the rays upon developing tissues.

SUMMARY

Investigators who have reported morphological and histological changes in treated plants have emphasized irregularities in leaf appearance, anomalies in shape and margins, variegations in leaf colors, including the appearance of chimeras. They have found that increased development of aerial as well as underground stems is of common occurrence in ray-susceptible plants while fasciations of stem and flower heads have been reported for a few species. Raying of budded plants seems to cause abscission of many buds; those which do bloom and develop fruits are usually abnormal and the fruits mature with a decreased number of seeds. Histological studies indicate the stems of treated plants show an early development of xylem made at the expense of the pith.

CYTOLOGICAL EFFECTS OF X-RADIATION

Lopriore (37), in 1898, found that treatment of *Vallisneria spiralis* produced an acceleration of protoplasmic streaming which was checked by longer exposure. Seckt (59) reported that exposure to X-rays distinctly favored the streaming movement of protoplasm of *Mimosa* and *Oxalis*. Williams (69), working with strips from the upper surface of the petiole of *Saxifraga umbrosa*, found that the circulation of cytoplasm was first accelerated by small doses of the rays, but that depression followed and there was no return to normal. There was evidence of a lowering of viscosity of protoplasm in the early stages of radiation. Weber (67), on the contrary, reported that in living plant cytoplasm no viscosity changes appeared as primary effects of the rays. Vintemberger (65) has shown that the protoplasm resists the action of the rays, or if injured by their passage, it is quickly repaired under the influence of the nucleus. The selective action of the rays is on the nucleus and chromatin.

The work of Jüngling and Langendorff (24) indicates that small doses which do not cause visible harm to the root tips of *V. Faba* make a change in the rhythm of nuclear division. A curve constructed to show the number of mitoses in unrayed root tips during a period of 24 hr. has but a single peak and is somewhat symmetrical. The maximum number of mitoses occur during the day; the minimum, at night. A similar daily rhythm in nuclear division of root tips has been found in the pea. After irradiation with a relatively light dose of X-rays, not 1 maximum but 2 maxima occurred within 24 hr. A curve showing 3 maxima was evident when the dose was doubled. Retardation of growth was manifest and the number of defective divisions increased with heavy doses. With a dose

so heavy that 90 per cent of the roots were dead after 14 days, the following occurred: after 1 hr., the mitosis number showed a 1 per cent increase which was followed by a rapid decrease; after 18 hr., a zero point was reached where no division occurred for 6 hr.; after 60 hr., a second peak was reached followed by a minimum at the 85th hour; the third and smaller maximum was evident at 96 hr., with the third minimum at 144 hr.; a flattening out of the curve then occurred. In general, it may be stated that for successively higher doses, there occur increasingly longer periods devoid of mitoses.

A mitotic decrease 3 hr. after irradiation with almost complete cessation after 3 days was reported by Wigoder and Patten (70). Cell division was resumed after 5 to 8 days when many abnormal, multinucleate cells were observed.

Nakagawa (44) reported rare occurrence of mitosis after irradiation of sprouted *V. Faba* seeds. He found it occurring only in the growing point where multinucleate giant cells appeared 45 hr. after irradiation.

Mitotic irregularities occur also in leaves of X-rayed plants. Displacement and replacement of tissues may be going on constantly to produce leaves irregular in form with puckered and roughened surfaces. Goodspeed (12) suggests that in tobacco leaves "the nucleo-cytoplasm ratio has apparently been altered, perhaps as a result of some induced inhibition of mitosis without decrease in the growth capacity of the protoplast."

Komuro (29), in 1922, from his studies on *V. Faba*, concluded that heavy doses of X-rays upon the seeds cause an abnormal condition in cells of the radicle. In preparations which Komuro (32) made of root tips of *V. Faba*, 1½ hr. after an irradiation of 1 hr., vacuolization of cytoplasm was apparent and all observed mitoses were abnormal. Nine hours after irradiation, binucleate cells, giant nuclei, and multinucleolar nuclei were found. He (31) later confirmed his earlier results and reported additional degenerative phenomena occurring in roots of *V. Faba*: irregular distribution of chromosomes, change in form and contents of the nucleus; appearance of multinucleate cells; a tearing away of the protoplast from the cell wall; vacuolization of both nucleolus and cytoplasm; dissolution of cell nucleus; thickening by contraction of the nucleus such as occurs during the degeneration of a cell. He writes: "It may safely be said that irradiation of X-rays upon the seeds, seedlings, and young plants of *Vicia Faba* leads the cells of the vigorous growing plant to a diseased or senescent condition resembling that of malignant tumor cells and then to the end of cell life." The soft rays exert a much stronger physiological and cytological effect than do the hard rays, according to Komuro (33). In young plants, cytological alterations take place immediately after treatment with soft rays; in case of hard rays, several hours later.

Rearrangement or translocation and losses of portions of the chromosome complement occur with very high frequency as a consequence of X-ray treatment—thus, Stadler (64) concluded from his studies on *Zea Mays*. In both translocation and deficiency, a part of a chromosome is separated from the remainder; in deficiency, this section is lost, while in translocation it becomes attached to another chromosome or section. Deficiency may involve a section of an entire chromosome and may be single or multiple; translocation, whether simple or reciprocal, may involve one or more transfers or interchanges. Combinations of deficiency and translocation also may occur.

Recent work by Narimatsu (45) on *V. Faba*, which confirmed results of certain authors mentioned previously, indicated that with weak irradiation there was no marked abnormality in cell arrangement as compared with the nonirradiated group. The most marked change was in the cell nucleus where mitoses were decreased. Degenerative changes and swelling of the cell body were more pronounced with medium irradiation, and abnormal cell arrangement occurred. With strong irradiation, swelling of the cell body took place and almost no structure was observed in the protoplasm. No mitoses were observed and the nuclei were swollen and degenerated. Narimatsu (45) concluded that the change in cell arrangement was not a direct result of irradiation but was secondary to change in the nucleus, since the part first affected is the nucleus.

Bersa (7a) concludes that so-called ray-resistant and ray-susceptible plants behave similarly cytologically. X-rays cause depression in frequency of nuclear division; the stronger the rays, the greater the depression. Prophases suffer only temporarily a stronger depression, which indicates that the rays delay appearance of division phases from the resting nuclei. Bersa did not observe abnormal mitoses until 36 hr. after irradiation.

There seems to be general agreement that cells of the growing tip are more sensitive to the action of the rays than those of other regions. The nucleus is more ray-sensitive than the cytoplasm; hence it is suggested that there may be an alteration in the nucleus-cytoplasm ratio when mitoses are decreased without a proportional decrease in the amount of protoplasm. Mitotic irregularities occur in the leaves as well as in the growing points of stems and roots. Numerous chromosomal irregularities, including rearrangement or translocation of portions of chromosomes, are evident after heavy irradiation.

GENERAL SUMMARY

The investigations reviewed in this paper have dealt with the physiological, morphological, histological, and cytological aspects of the effects of X-radiation on green plants. In spite of the large number of publica-

tions, there is still a need for careful experimentation in order that there may be agreement on certain essential points. The majority of investigators working on physiological phases of this problem have agreed that seed germination is not greatly influenced by X-rays and that medium to heavy doses cause injury to roots, stems, leaves, flowers, and fruits. While some believe that they can induce increased growth with light doses, others are equally certain that no such stimulation occurs.

Before the use of the dosimeter which gives an accurate measure of the ray intensity in r-units, there was no certainty that one experimenter could reproduce the dosage used by another. At present, however, if the number of r-units delivered during the exposure is given together with the voltage and filtration, the same dose can be duplicated on another machine. With more general use of this unit of dosage, more accurate information concerning the effects of light doses should be forthcoming.

Other factors contributing to differences in conclusions have been the use of seeds or plants so few in number that individual differences invalidate the results; conclusions were sometimes drawn from experiments performed but once; statements of results in growth experiments were often based on observations for very short periods of time so that it was not possible to tell of effects appearing during later development.

The question of sensitivity is important for the biologist as well as for one interested in radiotherapy. Investigators have found that different species as well as different individuals of the same species vary in their reactions to the rays. Some are particularly ray-sensitive. It is difficult to give a reason for the variation in response among different kinds of cells and in the same cell at different periods for, at the present time, we know too little concerning the nature of the changes which radiation produces. Sensitivity is thought to vary with the metabolic rate and with the amount of water present in the seed or plant tissue. Soaked or germinating seeds are much more susceptible to the rays than are resting cells. Respiration of rayed seedlings seems to parallel growth.

An interrupted dose has less effect than the same dose given all at one time, owing to the existence of a "radiophylactic" reaction. Little is known of the amount of energy which the cell absorbs. Some investigators have found that X-ray beams of equal intensity have the same biological effects irrespective of wave-length, while others believe that the long wave-lengths are harmful. It is to be hoped that future studies will give accurate information on this question as well as on the much debated question of stimulation with light doses.

Irregularities in shape, texture, and color of leaves developing from X-rayed material are of common occurrence. In general, blossoming is delayed and, if plants have been treated after buds are formed, abnormal flowers and fruits result. Histological studies of stems indicate that

treated plants show vascular tissue which is more mature than in control stems of equal age.

Cells of the growing tip are more sensitive to the rays than those of other regions; the nucleus is more sensitive than the cytoplasm. Many chromosomal irregularities are apparent after irradiation.

REFERENCES

1. ALTMANN, V., D. ROCHLIN, and E. GLEICHGEWICHT. Über den entwicklungsbeschleunigenden und entwicklungshemmenden Einfluss der Röntgenstrahlen. *Fortsch. Geb. Röntgenstr.* **31**: 51-62. 1923.
2. ANCEL, SUZANNE. Action de faibles doses de rayons X sur des grains sèches. *Compt. Rend. Soc. Biol. [Paris]* **91**: 1435-1436. 1924. (See also (a) *Ibid.* **93**: 1669-1670. 1925; (b) **93**: 1671-1672. 1925; (c) **96**: 986-989. 1927.)
3. ANCEL, SUZANNE. Recherche du meilleur test de la radio-réaction des graines des Légumineuses. *Bull. Soc. Bot. France* **73**: 71-73. 1926. (See also (a) *Ibid.* **72**: 1084-1088. 1926.)
4. ANCEL, SUZANNE. De l'influence accélératrice des rayons X sur le développement des plantes. *Arch. Phys. Biol.* **5**: 106-118. 1926.
5. ANCEL, P., and S. LALLEMAND. Sur la protection contre l'action des rayons X par une irradiation préalable (radiophylaxie). *Compt. Rend. Soc. Biol. [Paris]* **99**: 1588-1590. 1928.
6. ARNTZEN, L., and C. KREBS. Investigations into the biological effect of filtered and unfiltered X-rays as measured on peas. *Acta Radiologica* **4**: 5-31. 1925.
7. BERSA, EGON. Strahlenbiologische Untersuchungen. I. Sitzungsber. Akad. Wiss. Wien Math.-Natw. Kl. Abt. 1. **135**: 425-451. 1926. (See also (a) Paper II. *Ibid.* **136**: 383-402. 1927; (b) Paper III. *Ibid.* **136**: 403-418. 1927.)
8. CAPIZZARO, N. Sobre la acción biológica de las radiaciones Roentgen. Influencia de los rayons-X producidos por corrientes de alta tension y milliamperaje elevado sobre la germinación de las semillas. *Bol. Inst. Med. Exp., Buenos Aires* **2**: 922-928. 1926.
9. CATTELL, WARE. The effect of X-rays on the growth of wheat seedlings. *Science* **73**: 531-533. 1931.
10. GELLER, F. C. Die Wirkung der Röntgenstrahlen auf jugendliche Organismen. *Klin. Wochensh.* **3**: 561-566. 1924.
11. GLOCKER, R., E. HAYER, and O. JÜNGLING. Über die biologische Wirkung verschiedener Röntgenstrahlenqualitäten bei Dosierung in R Einheiten. *Strahlentherapie* **32**: 1-38. 1929.
12. GOODSPEED, T. H. The effect of X-rays and radium on species of the genus *Nicotiana*. *Jour. Hered.* **20**: 243-260. 1929.
13. GOODSPEED, T. H. Cytological and other features of variant plants produced from X-rayed sex cells of *Nicotiana tabacum*. *Botan. Gaz.* **87**: 563-582. 1929.
14. GOODSPEED, T. H., and A. R. OLSON. Genetic and other effects of X-ray and radium treatment of seeds, growing points, and sex cells of *Nicotiana* species. *Amer. Jour. Bot.* **15**: 622. 1928.
15. HALBERSTAEDTER, L., and A. SIMONS. Zum Problem der Reizwirkung der Röntgenstrahlen. Biologische Ergebnisse aus Versuchen an Pflanzen. *Fortsch. Geb. Röntgenstr.* **28**: 499-611. 1922.
16. HORLACHER, W. R., and D. T. KILLOUGH. Radiation-induced variation in cotton. Somatic changes induced in *Gossypium hirsutum* by X-raying seeds. *Jour. Hered.* **22**: 253-262. 1931.
17. IVEN, HUBERT. Neuere Untersuchungen über die Wirkung der Röntgenstrahlen auf Pflanzen. *Strahlentherapie* **19**: 413-461. 1925.

18. JACOBSON, M. Die Wirkung der Röntgenstrahlen auf das Wachstum der Pflanzen. Beilage Rigaschen Rundschau **54**: 5. 1923.
19. JOHNSON, EDNA A. Effects of X-rays upon growth, development, and oxidizing enzymes of *Helianthus annuus*. Bot. Gaz. **82**: 373-402. 1926.
20. JOHNSON, EDNA L. Growth and germination of sunflowers as influenced by X-rays. Amer. Jour. Bot. **15**: 65-76. 1928. (See also (a) *Ibid.* **18**: 603-614. 1931.)
21. JOHNSON, EDNA L. Effect of X-irradiation upon growth and reproduction of tomato. Plant Physiol. **6**: 685-694. 1931.
22. JOHNSON, EDNA L. The influence of X-radiation on *Atriplex hortensis* L. New Phytologist **32**: 297-307. 1933. (See also (a) Unpublished data.)
23. JÜNGLING, O. Untersuchungen zur chirurgischen Röntgentherapie. Strahlentherapie **10**: 501-507. 1920.
24. JÜNGLING, O., and H. LANGENDORFF. Über die Wirkung verschieden hoher Röntgendosen auf den Kernteilungsablauf bei *Vicia faba equina*. Strahlentherapie **38**: 1-10. 1930.
25. KELLCOTT, WM. E. The daily periodicity of cell division and of elongation in the root of *Allium*. Bull. Torrey Bot. Club **31**: 529-550. 1904.
26. KOERNICKE, M. Wirkung von Röntgenstrahlen auf die Keimung und das Wachstum. Ber. Deut. Botan. Ges. **22**: 148-155. 1904.
27. KOERNICKE, M. Über die Wirkung verschieden starker Röntgenstrahlen auf Keimung und Wachstum bei den höheren Pflanzen. Jahrb. Wiss. Bot. **56**: 416-430. 1915. (Pfeffer-Festschrift.)
28. KOMURO, HIDEO. Studies in the effect of Röntgen rays upon the development of *Vicia faba*. (Japanese). Reprint from Keiō Igaku (Keiō Med. Jour.) 1921.
29. KOMURO, HIDEO. Preliminary note on the cells of *Vicia faba* modified by Röntgen rays and their resemblance to tumor cells. Botan. Mag. Tokyo **36**: 41-45. 1922. (See also (a) *Ibid.* **36**: 15-17. 1922; (b) **38**: 1-20. 1924.)
30. KOMURO, HIDEO. Studies in the effect of Röntgen rays upon the development of *Vicia faba*. Jour. Coll. Agric., Imp. Univ. Tokyo **8**: 253-292. 1923.
31. KOMURO, HIDEO. The cells of *Vicia faba* modified by Röntgen rays, and their resemblance to malignant tumor cells with the cytological observations of tumors. Japanese Jour. Bot. **2**: 133-156. 1924.
32. KOMURO, HIDEO. Cytological and physiological changes in *Vicia faba* irradiated with Röntgen rays. Bot. Gaz. **77**: 446-452. 1924.
33. KOMURO, HIDEO. Die Wirkung der harten und weichen Röntgenstrahlen auf die Samen und jungen Pflanzen von *Vicia faba* und die Röntgengeschwulst, die in dem Wurzelspitzen Gewebe dieser Pflanzen gebildet wird. Zeitsch. Krebsforsch. **22**: 199-209. 1925.
34. KÜSTER, A. Die Wirkung der Röntgenstrahlen auf die nyktinastischen und seismonastischen Bewegungen. Fortsch. Geb. Röntgenstr. **40**: 242-248. 1929.
35. LALLEMAND, S. Étude de l'action des rayons X sur le développement des plantes. Arch. Anat. Hist. et Embryol. **10**: 1-233. 1929.
36. LALLEMAND, S. Étude de l'action des rayons X sur des phanérogames. Arch. Phys. Biol. **8**: 53-81. 1930.
37. LOPRIORE, G. The action of X-rays on the living plant cell. Nuova Rassegna, 1897. (Abs. in Bot. Centbl. **73**: 451-452. 1898.)
38. MCKAY, J. W., and T. H. GOODSPEED. The effects of X-radiation on cotton. Science **71**: 644. 1930.
39. MAISIN, J., and S. MASY. Au sujet du mécanisme d'action des rayons X sur les graines. Compt. Rend. Soc. Biol. [Paris] **98**: 886-8. 1928.
40. MALDINEY and THOUVENIN. De l'influence des rayons X sur la germination. Rev. Gén. Bot. **10**: 81-86. 1898.

41. MIEGE, E., and H. COUPE. De l' influence des rayons X sur la végétation. *Compt. Rend. Acad. Sci. [Paris]* **159**: 338-340. 1914.
42. MOORE, C. N., and C. P. HASKINS. Note on premature flowering in grapefruit from X-rayed seeds. *Science* **76**: 167-168. 1932.
43. MORGAN, W. P. Growth irregularities in hybrid freesias induced by X-rays. *Indiana Acad. Sci.* **41**: 139-144. 1932.
44. NAKAGAWA, T. The biological study of radiosensitivity. I. *Japanese Jour. Obst. and Gynecol.* **14**: 218-224. 1931.
45. NARIMATSU, K. Investigation of the histological change in plant shoots caused by X-rays. Especially the effect upon the arrangement of tissues in the seed of *Vicia faba*. *Japanese Jour. Obst. and Gynecol.* **14**: 50-58. 1931.
46. NAVASHIN, M. A preliminary report on some chromosome alterations by X-rays in *Crepis*. *Amer. Nat.* **65**: 242-252. 1931.
47. PATTEN, RUTH E. P., and SYLVIA B. WIGODER. Effect of X-rays on seeds. *Nature* **123**: 606. 1929.
48. PETRY, E. Zur Kenntnis der Bedingungen der biologischen Wirkungen der Röntgenstrahlen. II. Mitteilung. *Biochem. Zeitsch.* **128**: 326-353. 1922.
49. PFEIFFER, T., and W. SIMMERMACHER. The influence of Röntgen rays on the seeds of *Vicia faba* as shown in the development of the plants. *Landw. Vers. Stat.* **86**: 35-43. 1915.
50. PROMSY, G., and M. P. DREVON. Influence des rayons X sur la germination. *Rev. Gén. Bot.* **24**: 177-197. 1912.
51. REINHARD, M. C., and K. L. TUCKER. Hourly variations in effect of equal roentgen-ray doses on growth of *Vicia faba* seedlings. *Amer. Jour. Roentgenol.* **19**: 71-73. 1928. (*See also (a) Jour. Cancer Res.* **12**: 26-29. 1928.)
52. REISS, P. Sur l'excitation des bourgeons des plantes par les rayons X. *Compt. Rend. Soc. Biol. [Paris]* **92**: 984-986. 1925.
53. RIVERA, VINCENZO. Azione dei raggi Röntgen sopra meristemi normali di *Ricinus communis*. *Boll. R. Staz. Pat. Veg.* **6**: 144-152. 1926.
54. RIVERA, VINCENZO. Introduzione allo studio della radiosensibilità di *Vicia faba*. *Riv. Biol.* **8**: 505-539. 1926.
55. RUSS, SIDNEY. Growth and division of cells as affected by radiation. *Sci. Prog.* **13**: 605-613. 1919.
56. SCAGLIA, G., and O. BUSINCO. Effetti delle irradiazioni Roentgen sull'accrescimento di *Hyacinthus orientalis*. *Arch. Fisiol.* **29**: 48-87. 1930.
57. SCHWARZ, E. Der Wachstumsreiz der Röntgenstrahlen auf pflanzliche und tierische Gewebe. *Münch. Med. Wochensch.*, Nr. 39. 1913. (*See also Umschau* **18**: 15-16. 1914.)
58. SCHWARZ, G., A. CZEPA, and H. SCHINDLER. Zum Problem der wachstumsfördernden Reizwirkung der Röntgenstrahlen bei höheren Pflanzen. *Fortsch. Geb. Röntgenstr.* **31**: 665-680. 1924.
59. SECKT, H. Über den Einfluss der X-Strahlen auf den pflanzlichen Organismus. *Ber. Deut. Botan. Ges.* **20**: 87-93. 1902.
60. SHULL, C. A., and J. W. MITCHELL. Stimulative effects of X-rays on plant growth. *Plant Physiol.* **8**: 287-296. 1933.
61. SNYDER, G. E. Effect of X-rays on developing corn. *Proc. Pennsylvania Acad. Sci.* **4**: 32-34. 1930.
62. SPRAGUE, H. B., and M. LENZ. The effect of X-rays on potato tubers for "seed." *Science* **69**: 606. 1929.
63. STADLER, L. J. Some genetic effects of X-rays in plants. *Jour. Hered.* **21**: 3-19. 1930.
64. STADLER, L. J. The experimental modification of heredity in crop plants. I. *Scientific Agric.* **11**: 557-572. 1931.

65. VINTEMBERGER, P. Sur le résultat de l'application d'une dose forte de rayons X a une région de la cellule ne renfermant pas le noyau. *Compt. Rend. Soc. Biol. [Paris]* **99**: 1965-1967. 1928.
66. WEBER, F. Frühtreiben ruhender Pflanzen durch Röntgenstrahlen. *Biochem. Zeitsch.* **128**: 495-507. 1922.
67. WEBER, F. Röntgenstrahlenwirkung und Protoplasmaviscosität. *Pflüger's Arch. Ges. Physiol.* **198**: 644-647. 1923.
68. WERNHART, K. Influence des rayons X sur la germination et sur la croissance des végétaux. *Compt. Rend. Soc. Biol. [Paris]* **96**: 1090-1091. 1927.
69. WILLIAMS, MAUD. Observations on the action of X-rays on plant cells. *Annals Bot.* **37**: 217-224. 1923.
70. WIGODER, SYLVIA B., and RUTH PATTEN. Some effects of Röntgen rays on seedlings. *Proc. Roy. Irish Acad.* **39**: 146-155. 1929.

Manuscript received by the editor June, 1933.



XXX

THE EFFECTS OF RADIUM RAYS ON PLANTS

A Brief Résumé of the More Important Papers from 1901 to 1932

C. STUART GAGER

Brooklyn Botanic Garden

The discovery of X-rays by Röntgen in 1896 was followed in the same year by Becquerel's discovery that the various salts of uranium possess a hitherto unknown property of spontaneous radioactivity. After this discovery, M. and Mme. Curie, of Paris, began to examine different minerals containing uranium and found that of some 13 examined all gave off what were then called "Becquerel rays." The Curies concentrated their investigations on pitchblende, the most active of the uranium compounds studied, and in 1898 isolated *polonium* and proposed the new term, *radioactive*. Later in the same year appeared the epoch-making paper by the Curies and Bémont announcing the discovery of radium.

From that date to the present, there has persisted in physiological circles an unfortunate misunderstanding as to just what radioactivity is. Perhaps, therefore, it may not be amiss to state here that the element radium gives off three types of radiation which penetrate objects opaque to the rays of the solar spectrum. These are: the *alpha* rays (streams of particles bearing a positive electrical charge), *beta* rays (streams of electrons, bearing a negative charge), and *gamma* rays (a penetrating type of X-ray). In addition to these three types of rays, radium also gives off a chemically inert, radioactive gas. This is the *emanation*, more recently christened *emanium*. The atom of the emanation gives off only *alpha* rays.

It was about three years after the discovery of radium was announced before what is possibly the first paper appeared reporting experiments on the effect of radium rays on living organisms. This was a paper by Becquerel who reported in 1901 that an exposure of a week or more to radium rays destroyed the germinating power of seeds of cress and white mustard. Negative results followed an exposure of only 24 hr. The experiments were made in Becquerel's laboratory by Louis Matout.

Between Becquerel's pioneer paper and the year 1908, more than 100 papers were published reporting the results of investigations of the effects of radium rays on living plants. Most of these papers were cited and summarized by the writer in a memoir (25) on the *Effects of the Rays of Radium on Plants*. This memoir was referred to by Richards in

1915 as marking the end of the pioneer stage of investigations of the biological effects of radium rays.

The results published between 1901 and 1908 (26, page 69) have been summarized as follows:

1. Radium rays have the power to modify the life processes of both plants and animals.
2. Roentgen and radium rays produce similar physiological results.
3. Sensitiveness to these rays varies with the species of either plant or animal.
4. Younger, and especially embryonic, tissues are more sensitive than those more mature.
5. With only one or two exceptions, exposure to radium rays has been found either to retard or to completely inhibit all cell activities. The rays may cause irregularities in mitosis.
6. Experimental evidence for or against the existence of a radiotropic response is conflicting.
7. Whatever the immediate, internal change produced in the protoplast may be, the result, with animals as well as with plants, appears to be more or less profoundly modified by the presence of chlorophyll in the cell.
8. Radium rays appear to retard the activity of enzymes.

In Chap. II of this memoir, the then existing literature was reviewed showing that radioactivity and free electrons are a part of the normal environment of probably every plant. The new work reported included a study of the effect of the rays of radium and of its radioactive emanation on various physiological processes of plants, as follows: (a) germination of seeds; (b) growth; (c) photosynthesis; (d) conversion of sugar to starch in plant tissues in darkness; (e) respiration (aerobic and anaerobic); (f) alcoholic fermentation; (g) tropistic response; (h) nuclear division.

In addition, studies were made of histological modifications produced by exposing growing roots, stems, and leaves, including nuclear structure, and also effects that followed the exposure of germ cells to the rays.

It would appear that in this memoir there was reported for the first time experimental evidence that the rays of radium may, under suitable conditions of exposure, induce an acceleration of vital functions. Thus, by inserting a sealed glass tube of radium bromide into soil at suitable distances from newly planted seeds their germination and the subsequent growth of the seedlings were markedly accelerated. Only retardation or cessation of germination and growth, or the killing of the seeds, had hitherto been reported. It was found that the processes of respiration and alcoholic fermentation might be greatly accelerated. Previously, Dixon and Wigham (in 1904) reported that exposure to the rays checked the action of enzymes, and Micheels and de Heen (in 1905) observed that the rays retarded respiration. Guilleminot, in 1907, referred to an accelerating action, *if such exists*.

The experimental results led to the broad generalization that radium rays act not, for example, like a stroke of lightning or immersion in boiling water, but as a true *stimulus* to metabolism. "If this stimulus ranges

between minimum and optimum points, all metabolic activities, whether constructive or destructive, are accelerated; but if the stimulus increases from the optimum toward the maximum point it becomes an over-stimulus, and all metabolic activities are depressed and finally completely inhibited. Beyond a certain point of overstimulus recovery is impossible, and death results."

A second broad generalization was also stated as follows: "If the living matter itself is directly affected by the rays it is difficult to conceive how any one function could be modified without the others being affected for, with long periods of exposure . . . to rays of high activity . . . it is certain that the protoplasm will have its vitality partially or wholly destroyed,¹ and all 'vital' processes correspondingly modified or stopped. But, on the other hand, the modification or total inhibition of any one process does not necessarily indicate that the living matter has been directly affected, for such a condition would result, if, as in the case of the resting seed, the rays destroyed an enzyme essential to the completion of some function."

Besides demonstrating that radium rays act as a true stimulus, the work referred to served to suggest the direction that future investigations should take. Of course, after anything has been found to act as a stimulus, the effects of subjecting living organisms to it may be *predicted* along broad lines (acceleration, retardation, inhibition of functions, or killing the tissue or organism), but these effects need to be worked out in detail, stated quantitatively, analyzed as to *modus operandi*, and practical applications, if any, pointed out and tested.

In a later paper Gager (26) reviewed the more important literature that had appeared between 1908 and 1916. In a work appearing first in 1915, revised in 1924, Colwell and Russ (17) devote two chapters to plant material, but the survey is inadequate, and no attention is given to American literature. Up to 1908 certain crudities were inevitable. No precise quantitative method had been devised for expressing the radioactive strength of radioactive compounds. There was no universally recognized *unit* of radioactivity. Preparations of radium bromide in sealed glass tubes were indicated as having various "activities," *e.g.*, 10,000, 1,500,000, 1,800,000, meaning that the preparation was that much stronger than an equal weight of uranium, for Eve had shown that the activity of radium is a function of the amount present. Rutherford had shown that the intensity of activity did not vary with the concentration of the salt. In his experiments, "a distribution of radiating matter over a thousand times its original volume has no appreciable influence on its original activity."

But there was no precise manner of designating the dosage at varying distances of the active preparation from the plant, or of taking account

¹ This would have been differently worded at the present time.

of the effect of the thickness or material of the wall of the container. In other words, precise quantitative work was impossible. Technique had also not been perfected for differential tests of the three different types of rays—alpha, beta, and gamma.

Guilleminot had recognized this need in 1907, and proposed as a *unit of intensity* (M) of the field of irradiation the quadruple of the intensity producing the same luminescence as a standard of 0.02 gm. of radium bromide of 500,000 activity,² spread over a circular surface of 1 cm. in diameter, and placed at a distance of 2 cm. from the phosphorescent surface. Then the unit of quantity of radiation will be the quantity acting for 1 min. when the field has one unit of intensity. Investigations, however, were carried on from 1908 to 1916 with and without (mostly without) reference to this unit.

In 1905, Dr. H. Mache, of Vienna, studied the radioactivity of springs and rivers of Bohemia and Austria. This radioactivity, of course, is very weak, and Mache proposed and defined a mass unit of the concentration of the emanation found in springs, etc. If the quantity of emanation found in one liter of the water tested is passed through an electroscope and the radiation given off can maintain a saturation stream of 1×10^{-3} electrostatic units, then the water has an emanation content of one Mache unit (1 ME). $1 \text{ ME} = 3.64 \times 10^{-10}$ curie/liter. There was later proposed for the concentration of emanation the unit, 1 "Eman" ($= 10^{-10}$ curie/liter).

In 1910 the International Congress for Radiology and Electricity, Brussels, proposed as the unit of radium emanation the amount of emanation in an enclosed container which is in equilibrium with 1 gm. of metallic radium. This unit was called a *curie* after M. Curie, who was the first to devise a quantitative method of measuring the emanation. One Mache unit $= 4 \times 10^{-10}$ curie or 4×10^{-7} millicurie. A millicurie and a microcurie are the quantities corresponding respectively to 1 mg. and 0.001 mg.

Since the paper of Gager (26) is readily available, it is not essential here to review the literature of that period in detail. Because of its bearing on the subject of photosynthesis, mention should be made, however, of the work of Stoklasa, Šebor, and Zdobnický (84) in 1911 and 1913, who reported that "under the influence of the emanation of radium, hydrogen, and carbonic acid, in the presence of potassium bicarbonate, react to form formic aldehyde which, on contact with potassium, polymerizes and gives reducing sugars" (see 84, page 648). Whether or not radioactivity is involved as an essential factor in the normal process of photosynthesis has never been demonstrated.

In the earlier work it was determined that embryonic tissue (*e.g.*, cambium) is more sensitive to the rays than mature differentiated tissue,

² That is, in terms of an equal weight of uranium.

and Gager (26) called attention to the importance of this fact in connection with the medical use of radium, especially in the treatment of cancers and tumors, whose growth might possibly be promoted instead of retarded under certain conditions of exposure to the rays. It was also pointed out that, since cambium is specially susceptible to injury by radium rays, no hope could be entertained of controlling the chestnut-blight fungus [*Endothia parasitica* (Murrill) And.] by injecting radioactive solutions into chestnut trees.

The possibility that crop production might be increased by adding radioactive substances to the soil, either with or without ordinary fertilizers, naturally aroused considerable interest. Ewart's experiments in Australia, in 1912, led him to the conclusion that a radioactive mineral, known to accelerate the germination of wheat seeds, did not appear to have any direct agricultural value, at least so far as wheat is concerned.

Experiments on the exposure of cultures of nitrifying and denitrifying bacteria to the emanation from pitchblende led Stoklasa (78) to infer that radioactive substances in the soil might increase fertility by promoting the circulation of nitrogen. There followed a series of papers reporting tests of the possibility of utilizing radium rays to increase crop production. Sutton and Sons, of Reading, England, issued a leaflet in 1914, reviewed in the *Botanical Journal* (October, 1914). They used radioactive ores mixed in small quantities with the soil. They reported that by such treatment the germination of rape seed was accelerated. The following year Martin H. F. Sutton (86) experimented with tomatoes, potatoes, lettuce, radishes, marrows, beets, carrots, onions, and several flowering plants, exposing the planted seeds to gamma rays given off by about 0.00025 mg. of radium bromide in glass bottles inserted in the soil. The results led to the conclusion that gamma rays, under the conditions of the experiments, tended to inhibit plant growth.

Ross (67) reviewing in 1914 the published results of experiments to test the value of radioactive substances as fertilizers, closed his summary as follows:

Evidence is given to show that the action of uranium on plants is due to its chemical properties rather than to its property of being radioactive, and that the conflicting results obtained with radioactive manure from different sources is to be explained largely by the presence of uranium, and of such nonradioactive constituents as soluble salts and free acids. . . . The radium present, on an average, in an acre-foot of soil is about 100 times greater than is contained in the quantity of radioactive manure commonly recommended for application to an acre.

At this period a "radioactive" fertilizer was being offered for agricultural use by the *Banque du Radium* (Paris). Stevens (Stevens Indicator, April, 1914, page 150) found that growth was accelerated only when as

much as 2.5 per cent of the compound was applied to a soil. In agricultural practice this would require about 25 tons to the acre, at a cost to the farmer of about \$5000 per acre.

The practicability of radioactive compounds for fertilizing on a commercial scale was tested by Hopkins and Sachs (36, 37). They also critically reviewed the previous work and reached the conclusion that there is no foundation in fact for reasonable expectation of increased crop yields, when financial possibilities are considered. They pointed out that radium to the value of \$1000 (10 mg.) on one acre would, during 100 days of good crop-growing weather give off energy equal to only 1 hp. for 22 sec.; and that the heat given off to the soil by that much radium in 100 days "would be less than the heat received from the sun on one square foot in thirty seconds."

Later, Ramsey (65) calculated that the average soil of a field contains 10 times as much radium naturally as is contained in the amount of a certain "radium fertilizer" recommended by the commercial concern offering it for sale.

Pilz (64) concluded from experiments that the utilization of mineral nutrients by plants "fertilized by radium" was better than with plants not so fertilized, so far as nitrogen, potassium, and sodium are concerned, but poorer for phosphoric acid. Miklaur and Zailer (49) reported no increase in crop production when oats (*Avena sativa*) were grown in soil containing radioactive residues from Joachimsthal.

The relative sensitivity of green plants in light and darkness was tested by Packard (61). Willcox had shown in 1904 that the green *Hydra viridis* was much more resistant to radium rays than the brown form (*Hydra fusca*). Packard tested *Spirogyra* and *Volvox* and found that the deleterious effects observed began to be manifested much more quickly when the exposure was made in the dark. "It is very evident," he said, "that the life of the cell is prolonged by some condition connected with photosynthesis."

Since this is not intended to be an exhaustive digest of the literature, other papers must be passed over. Some of them are reviewed by Gager (26), especially one by Ramsay (65), in which he pointed out that, in order to double the amount of radioactive emanation normally in the soil, "one must use about 75 mg. of radium per acre," at a cost of several thousand dollars per acre. Therefore, whether crop yield could be increased by adding radioactive preparations to the soil can have only academic, if any, interest. Experiments of the writer with a commercial "fertilizer" advertised as radioactive were reported in 1916 as giving absolutely negative results when the "fertilizer" was mixed with garden soil. A similar conclusion was stated by E. J. Russel in 1916, who cautioned against "the danger of arguing from a simple physiological observation to a complex phenomenon like the growth of a plant in soil."

A few papers not noted in the two reviews of literature cited above may be briefly mentioned here. Hebert and Kling (33), reported that radium radiations appeared to produce no alteration of the atmosphere in which plants were growing. Photosynthesis was not possible under radium rays alone, sunlight being excluded. Respiration and photosynthesis were considerably diminished in leaves exposed to the radiation before being placed in daylight, but the ratio between oxygen taken in and CO_2 given off in respiration was not altered by previous exposure to the rays.

Aequa (1) reported that certain species are more susceptible to the rays than others. The root systems seem to be more susceptible than the stems and foliage. Some pollen grains appeared not to be affected by exposures that were fatal to others. The movements of protoplasm in such cells as the epidermal hairs of pumpkin, the internodal cells of *Chara*, and the leaf cells of *Elodea canadensis* appear to be wholly unaffected by exposure to radium rays. Observations of the writer are in harmony with those of Aequa on this point.

Fabre (22) exposed unopened flower buds and ovaries of *Lilium* sp. to rays of different strengths. Buds were arrested in growth and soon dried up; ovaries, stigmas, and anthers were atrophied or retarded; pollen grains had poorly developed nuclei or none at all; pollen grains did not germinate on the stigma; ovules and embryo sacs were atrophied.

Gertz (27) reported that radium rays completely checked the twining of *Cuscuta* and the formation of its haustoria. In the same year, Guilleminot (32) reported that seeds exposed to X-rays of 15,000 M (his unit defined above) and radium rays of 3000 to 5000 M germinate in the same proportions at the end of two years of rest following exposure as at the beginning of the two years of rest. In other words, the injurious effect of exposure persists for two years. Since the seeds were in the resting condition when exposed and for two years thereafter, this result is what might have been expected.

Gager had shown in 1908 that air containing emanation was injurious to the germination of seeds under the conditions of his experiments, and similar results were reported by Fabre (23) for the germination of the spores of *Sterigmatocystis* on acid gelatin, using emanation of "high potency." One-half microcurie per cubic centimeter of air retarded germination for the first three days, but on the fourth day the growth of the exposed spores equaled that of the control cultures not exposed. *Mucor mucedo* was more resistant. There was observed only a retardation of growth with doses below 1 microcurie to 2 liters of air; with larger doses the suppression of the sporocysts. A dosage 1000 times stronger favored the germination of spores on gelatin and the development of the fungal filaments.

However, Fabre reported that seedlings of *Linum catharticum* exposed to emanation in the air of a closed vessel were killed at a strength of 40

microcuries per liter of air. These results were in harmony with those reported by Gager. When germinating seeds were exposed in a closed vessel to emanation given off from a solution of a radium salt, Doumer (21) found that germination was favored. Stoklasa (77a) reported similar results the same year.

Congdon (18, 19) was one of the first to endeavor to analyze the effect of the different types of rays. Using seeds of *Sinapis nigra*, *Panicum germanicum*, *Amarantus monstrosus*, *Nicotiana Tabacum*, and *Papaver somniferum*, he found that the effect of beta rays varied with their penetrating power. The slower, less penetrating secondary rays retarded germination more than the more penetrating primary rays and in direct proportion to their ionizing power. As might have been anticipated, Congdon found the embryos more sensitive than the surrounding endosperm of the seeds, and that the presence or absence of the testa and the position of the radicle toward or away from the source of the radiation affected greatly the sensitiveness of the seeds.

Molisch, tested, in 1905, the power of radium rays to cause tropistic responses, using seedlings of vetch, lentil, and sunflower, and also *Phycomyces nitens*, but reported negative results for shoots, as had Gager also. Molisch (52, 52a) returned to this problem in 1911, using stronger radium preparations that gave off a more intense illumination, and found that, at short distances tropistically sensitive plants, such as young seedlings of oat and vetch, gave positively phototropic responses, but others less sensitive, such as barley and sunflower, gave no response. Gager (25) reported a positive tropistic response of roots of *Lupinus albus* to a sealed tube containing radium bromide of 10,000 activity suspended at distances of 10 mm. to 2 mm. from the tips of the roots. These curvatures were interpreted, not as direct responses to the rays, but as possibly due to ions produced by the rays in the liquid.

The effect of radium rays in forcing plants was also investigated by Molisch (53). He found that when pipettes containing a small amount of radium bromide were attached to the branches of lilac bushes (*Syringa vulgaris*), the buds were forced. The longer the exposure (20, 48, 72 hr.), the quicker the response. Similar results were obtained by exposing chestnut branches (*Castanea*) for one day. Tulip, bladdernut (*Staphylea*), and maple (*Acer*) gave indifferent results, and *Ginkgo*, *Platanus*, red beech (*Fagus*), and *Tilia* all gave negative results.

Two years later, Molisch (54) reported that beta and gamma rays of radium stimulate resting buds of *Syringa vulgaris*, especially when the exposure is made in the second half of November and in December. But in January a longer irradiation (72 hr.) produces no effect, or, if so, an injurious one. Similar but more striking results were produced by radium emanation, using *Syringa vulgaris*, *Aesculus Hippocastanum*, *Liriodendron tulipifera*, *Staphylea pinnata*, and *Acer platanoides*. But

negative results were obtained with *Ginkgo biloba*, *Platanus* sp., *Fagus sylvatica*, and *Tilia* sp. Molisch suggested that the radium rays produced these results by activating certain ferments or in favoring their production, thus resulting in an activating of the nutrient materials.

Gager (25) reported that the growth of corn (*Zea Mays*) was accelerated by soaking the corn grains, before planting in soil, for 24 hr. in water which had been exposed to radium rays for 26.5 hr. by suspending in it a sealed glass tube containing radium bromide of 10,000 or 1,500,000 activity. The radicles of *Lupinus albus* were retarded in growth when immersed in water previously exposed for 24 hr. to radium rays of 10,000 to 1,500,000 activity. Similar effects were produced by immersing the radicles of *Lupinus* in freshly fallen rain water (which is known to be radioactive) as contrasted with growth in rain water one month old. The water in each experiment was caught by placing glass beakers in the open during a rain.

Stoklasa (77), however, reported that the radioactive water obtained from Joachimsthal stimulated the growth of roots and shoots of *Triticum vulgare*, *Hordeum distichum*, *Vicia Faba*, *Pisum sativum*, *Lupinus angustifolius*, *Trifolium pratense*, and *Pisum arvense*. Striking effects were obtained in 8 hr. with barley (*Hordeum*). He also found that vegetative processes are stimulated when 0.5 to 1.0 gm. of radioactive pitchblende inclosed in glass is placed in jars containing growing plants.

These results of Stoklasa were confirmed by Petit and Ancelin (62). They obtained water charged with emanation to the desired degree by keeping it in a fountain of radioactive cement, made by incorporating concentrates of radium in the cement. Seeds of "ray grass," wheat, and corn (*Zea Mays*) germinated much better in the radioactive water. They report that the influence of the radioactivity begins to show itself only after 12 days, on an average.

In 1913 and 1914, Stoklasa (78) published a series of papers on the significance of radioactivity in physiology. He reported that he and his coworkers found that exposure to the emanation of 80 to 150 ME promoted the metabolism of bacteria but retarded the reduction of nitric acid to elementary nitrogen by the organisms concerned in that process. When a mixture of yeast was exposed to emanation of 100 to 200 ME per liter of air, the absolute amount of the energy release of the yeast cells was increased. Fermentation began earlier in nutrient media containing yeast, and respiration was 70 to 110 per cent greater than normal under conditions of exposure. These results are in harmony with those reported by Gager (25).

Seedlings grown in radioactive water of 70 ME had a dry weight 0.62 to 158 per cent greater than those grown in ordinary water for the same length of time (Stoklasa, 78). Plants so exposed flower sooner and produce more seed. An excessive amount of irradiation retards and

injures (as others had found). Photosynthesis and respiration were both accelerated. Numerous experiments have shown that by exposure to weak radioactivity nuclear and cell division, the development of the plant as a whole, exchange of gases in photosynthesis and respiration, metabolism, flowering and fruiting are all favored by weak and retarded by strong irradiation. The same general conclusion was drawn from the sum total of work cited above in 1908, but by 1914 it had, of course, been more thoroughly documented.

The effect of radium rays on the germination of seeds was again investigated in 1915 at the Institut Pasteur, Paris. Agulhon and Robert (2) confined their studies to the period when the young seedling was still wholly dependent on the food reserves stored in the seed. First, peas (*Pisum sativum*) were exposed to such rays as could pass through the thin walls of sealed glass tubes. Second, they were germinated in a solution containing radioactive material. Third, germination was brought about in an atmosphere containing the emanation. In the first case germination was retarded, in the second the results were negative, in the third early growth was accelerated and etiolation resulted.

After 1915 there were few, if any, papers on the effects of radium rays on plants until about 1920. This hiatus was doubtless due to the World War. G. Hertwig (34) reported that investigations on the effect of the rays of radium and X-rays on algae and fleshy fungi showed retardation of growth, and that the reproductive cells of higher plants were more sensitive than other cells, thus confirming results previously reported (Gager, 25). Pollen grains of a carnation and of *Digitalis purpurea* would not germinate after exposure.

The action of buried tubes of radium emanation on neoplasias in plants was investigated by Levin and Levine (44). They found that when a radium emanation tube (of capillary size) is inserted in normal adult tissue, the only perceptible result is the complete destruction of tissue in the immediate vicinity of the tube, owing to the gamma radiation. When such a tube was inserted into crown gall tissue the further development of the tissue was inhibited. This is brought about by the inhibition of the nuclear proliferating activity in the tumor cells by the gamma rays. "The tumor tissue in the immediate vicinity of the buried tubes is affected mainly by the soft beta rays. Here, therefore, deeper changes take place in the tumor tissue. Sections of this tissue show the collapse of cell walls radially to the capillary tube, forming a cushion of cellulose. The cells immediately behind this cushion are devoid of both nucleus and cytoplasm. . . . The disintegrated tissue and the cellulose cushion filter off the soft gamma rays. Cells further back of this area are consequently acted on only by the gamma rays."

In a later paper, Levine (45) reported studies leading to the conclusion that short exposures of crown gall tissue to small doses of radium emana-

tion (0.1 to 0.6 millicurie) sealed in glass capillaries which are implanted in the crown gall tissue produce little effect on the surrounding tissues. Longer exposures and larger doses induce necrosis of tissues immediately surrounding the tube extending progressively to a radius of 0.5 to 5 mm.

The same author (Levine, 46), reported on the influence of filtered and unfiltered radium emanation on microsporogenesis of species of *Lilium* (*L. Harrisii*, *L. giganteum*, *L. auratum*, and *L. superbum*). The radium varied in strength from 0.25 to 3.3 millicuries, and the filters were of platinum, silver, and aluminum of 0.5 mm. in thickness. Various abnormalities and injuries that followed the exposure are described and figured. Three pages of bibliography are given.

The effect of radium rays on "vegetable cancers" was investigated in Italy by Rivera-Attilj (1925). Pichler and Wöber (63) found that, while ultra-violet rays and roentgen rays could be used successfully in the treatment of smutted wheat, the rays of radium were ineffective (at least under the conditions of the experiment).

Beginning in 1922 Emmy Stein published a series of papers, the first one dealing with the effect of the rays on the growing points of shoots and on seeds. Only the beta and gamma rays were employed. Exposures of growing points for 20 to 160 min. checked growth temporarily and caused floral abnormalities of several types. Later the plants assumed normal behavior. The material was from the pedigree cultures of Professor Bauer. No mutation resulted. Seeds exposed 1.5 hr. gave rise to aberrant forms ("radium plants"), some of which were regarded as true mutants, since no such forms had previously appeared in Professor Bauer's cultures. The abnormality was in one case repeated in the second generation. When propagated by cuttings, the "radium plants" preserved their mutant characters, though single branches of 10 reverted to normal except that they were sterile.

The poisonous effect of selenium on the germination of seeds was studied by Stoklasa (79, 79a), who found that this effect was largely removed when the seeds were germinated and grown in aqueous solutions either naturally radioactive or rendered so artificially by the presence of radium emanation. In other words, the rays from the emanation counteracted the toxicity of the selenium. The seeds used were *Hordeum distichum*, *Triticum vulgare*, *Secale cereale*, *Avena sativa*, *Vicia Faba*, and *Polygonum fagopyrum*, cultivated in the presence of selenite (Na_2SeO_3) or of selenate (Na_2SeO_4) of sodium. The emanation was supplied at the rate of 0.0000056 mg. (= 14 ME) per plant per day.

Nadson (58) investigated the effect of radium on yeast fungi in relation to the question of its effect on living substance in general. He found the following organisms possessed sensitivity to the rays in the order named, the first being most sensitive: *Endomyces vernalis*, *Saccharomyces cerevisiae*, *Nadsonia fulvescens*, *Cryptococcus glutinis*. Young

cultures were reported as, in general, more sensitive than older. The variations induced by the radium were reported to be inherited in the next generation. There was a retardation of growth, and 5 to 6 days after irradiation atypical growth forms appeared. Morphological variations were observed, such as long, threadlike cells with the cytoplasm homogeneously vacuolated and the nucleus located at the end; greatly enlarged club-shaped cells; much thickened cell walls (a protective device against the radium); amoeboid forms; nuclear degeneration. The normal glycogen formation of *Saccharomyces* was inhibited, and carbohydrate formation in *Cryptococcus*. *Saccharomyces*, *Cryptococcus*, and *Nadsonia* formed resting cells which gave rise to normal generations.

The structural abnormalities appeared (were "inherited") in successive generations—in some races for 40 to 60 and in one race for as many as 100. Such races have, by some authors, been interpreted as true mutations, but since no previous alterations of the genotype had been recorded for these organisms, Nadson did not call them mutations, but "persisting modifications" (*Dauermodifikation*). In these experiments, Nadson used 5 to 10 mg. of radium bromide under thin sheets of mica.

In a later paper, Nadson (59) reported experiments which led to the conclusion that roentgen rays and the beta and gamma rays of radium accelerate the tempo of life and thereby induce a premature senescence—a consequence of an excess of stimulation which became, in effect, an irritation.

Kotzareff and Chodat (43) exposed yeast cultures in eider (*Mosl*), by adding 0.25 millicurie of radium emanation. Budding and fermentation were stimulated. With a dose of 2 millicuries cell multiplication was decreased and fermentation reduced one-fifth. Stronger dosage (5-6 millicuries) completely inhibited fermentation and caused hypertrophy of the cells through strongly reducing their power to divide. When the culture was transferred to an emanation-free medium, normal growth and fermentation returned.

Various attempts have been made to analyze the mechanism by which radium rays produce their effects on living cells, tissues, and organisms. Redfield and Bright (65a) investigated this problem by exposing radish seeds in a dry condition to the beta and gamma rays by placing in a test tube seeds "closely packed about a glass tube containing radium emanation." The alpha rays were, as usual, screened out by the glass walls of the emanation tube. The effect of the gamma rays was considered negligible owing to their limited absorption by the seed. Two days after radiation the seeds were moistened and their production of carbon dioxide determined. They were then given an opportunity to germinate and grow. It was found that, while growth was retarded by the rays, the rate of carbon dioxide production in exposed seeds was invariably greater than in the unexposed control. Thus it appears that,

contrary to the results of Kimura in 1929, changes in the rate of carbon dioxide production and cell-division do not always go hand in hand. One process may be increased by exposures which retard the other. In other words, the rays have a specific action on certain physiological processes in contrast to others. One should not, therefore, make any broad generalization concerning their action on metabolism as a whole.

In 1925, a stimulating paper was published by Blaauw and Heyningen (7) on the radium-growth-response of one cell. The authors had previously determined experimentally that unicellular organs, such as the sporangiophores of *Phycomyces*, and also various multicellular organs of higher plants respond to light stimulus with characteristic accelerations and retardations of growth. The present paper gives the results of an investigation to determine whether the growth of unicellular sporangiophores, so sensitive to visible light, is also affected by radium rays. The light-growth-response (visible spectrum and ultra-violet) is characterized in these cells by an acceleration of growth (positive response), beginning after at least 3 min., and changing into a temporary retardation. The radium-growth-response was found to be just contrary to the light-growth-response, beginning with a strong decrease of growth, then, on account of a contrareaction, passing into an acceleration of growth. With continued exposure the growth "recovers its equability."

The radium-growth-response is considered by the authors as a secondary phenomenon—a result of more primary responses or modifications, brought about in the metabolism of the cell by the influence of the rays, "but which are for the present absolutely beyond our understanding." It is of interest to compare these results and the discussion with those of Redfield and Bright, above noted.

Blaauw and Heyningen found that the radium-growth-response follows more quickly than the light-growth-response; the former is perceptible after an average of 2 min., and the latter after 3.5 min. The sporangiophores of *Phycomyces* never showed any trace of a radiotropic curvature; the strong growth response followed a one-sided exposure to the radium. This is explained by the fact that the radium rays pass through the thin cells so perfectly that there is no difference of their intensity within the cell. The experiments indicate that the radium-growth-response is caused by the gamma rays exclusively.

But just as Sierp, with *Avena sativa*, and later Tollenaar had demonstrated dark-growth-responses for various organs, as soon as a long exposure to light is stopped, so it was found by Blaauw and Heyningen that, after the growth has become steady again after long exposure to radium, the radium preparation cannot be removed without causing a new reaction contrary to the first. This response, caused by the removal of the radium rays, is called *deradiation response*. In other words, if we define *stimulus* as any change in any factor of the environment, and

response as any activity or modification of activity tending to restore perfect adjustment of the organism to its environment, we see that when the radium rays are first introduced (stimulus), the retardation of growth (response), under suitable conditions of strength and duration of stimulus, is followed by a condition of *tonus*, the sporangiophore becoming adjusted to its new environment which includes the radium rays, and growth becomes steady again. Then, when the radium is removed, another stimulus is thereby produced to which the sporangiophore again makes response. Blaauw and Heyningen note that the initial influence of the light rays and the gamma rays is of quite a different nature, touching a quite different "link of the process of metabolism."

In studying the action of radium rays on plant cells Maud Williams (87) used strips of tissue from the upper surface of the petioles of *Saxifraga umbrosa* and, for comparison, the movement of the chloroplasts in the leaf cells of *Elodea*. After a short exposure there is an increase in the rate of protoplasmic circulation. The cells were rendered permeable and slow exosmosis of solutes can occur before any visible changes are found in the protoplasm. "Large dosage" produced shrinkage of the protoplast and vacuolation effects. Aftereffects "of more profound nature" than the immediate effects are reported. For example, if the radiation ceased before any shrinkage of protoplasm had taken place, and the material was then placed in fresh tap water and kept in darkness for 24 hr. or longer, great differences between these cells and those of the control material became visible. The protoplasm, often very discolored, either collected in a dense mass in the middle of the cell or became very dense at one end and very vacuolated at the other. The chloroplasts did not lose their color or appearance. The length of exposure needed to produce this after-appearance, depended upon whether *Saxifraga* or *Elodea* was used, and also upon the season of the year when the tests were made. Any change is irreversible after it has once become visible.

The modification of the physiological action of radium rays by the presence of various chemicals has been investigated by several authors. Rouppert and Jedrzejowski (68) exposed pieces of leaves of *Ficus Ficadatsura* having their lower surface covered with unicellular emergencies, and likewise young sprouts of *Leea coccinea* for 18 hr. to alpha, beta, and gamma rays of radium and of the "active deposit" of strengths 15 and 3 millicuries, respectively. With 15 millicuries the pieces of leaves and their unicellular emergencies of *Piper* were killed, but the multicellular emergencies of *Leea* remained alive. In the second case (3 millicuries), all the emergencies remained alive whether the subjacent tissues were killed or not. Even when the emergencies were nearer to a radium tube than the body of leaf tissue, they remained turgid and uninjured. The authors believe that the resistance of the emergencies is due to the

kations of K in the protoplasts, thus confirming earlier conclusions of Nadson and Žolkevič.

A. Sartory, R. Sartory, and J. Meyer (70, 70a) studied the formation of perithecia in *Aspergillus fumigatus* Fresenius under the influence of radium. In their first paper they state that they made use of *Aspergillus fumigatus* [sic] "because its characters and properties are known and fixed." Four culture media were employed: glucose nondissociated; glucose dissociated by sodium chloride; saccharose nondissociated; saccharose dissociated by sodium chloride. The work was divided into two parts: (a) A series of exposures on all four media distributed over a period of 15 days and at increasing doses of from 150 to 750 microcuries and 1.2 to 2.4 millicuries (strong doses). Observations were made 12 hr. after each exposure. (b) A series of exposures on all four media with "strong" irradiations for 2 hr. at a dosage of 7.2 millicuries. Under the various conditions the following results were recorded: (a) A stimulation of the formation of the reproductive apparatus. The conidiophore swelling was replaced by a tufted growth (*formes penicilliennes*); the sterigmata assumed pronounced giant forms. When the dosage was strong, these results were more pronounced. (b) Cultures on nondissociated media exposed discontinuously to 3 to 7.2 millicuries showed a retardation of the appearance of the reproductive structures and a modification in the form of the mycelial threads. The authors note that, in a nondissociated medium, the radiation increases the reducing power of the organism and lowers the hydrogen ion concentration of the medium. On the other hand, in the dissociated medium, the irradiation diminishes the power of the organism to reduce saccharose and increases the hydrogen ion concentration.

In two subsequent papers, these authors describe experiments which lead them to the conclusion that the action of radium rays on *Aspergillus fumigatus* [sic], cultivated on a medium of carrot juice gelatin (pH = 4.7), dissociated by sodium chloride, and only on that medium, causes the formation of fertile perithecia, with well-defined asci and ascospores.

In 1926, Stoklasa referred in a general way to experiments he had made since 1906, which have yielded cumulative evidence that radioactivity affords an important means of attacking biological problems. All plants, he says, are weakly radioactive. He notes that the primary step in respiration is always intracellular, and it is this—a reducing process—which is increased by radium rays, especially the beta rays. The rays furnish an impulse to the rearrangement of the atoms in the molecule of sugar, resulting first in the formation of lactic acid from which arise carbon dioxide, alcohol, and finally acetaldehyde and acetic acid. It is the oxidation processes, caused by oxidase and peroxidase, that are stimulated by the alpha rays of radium, forming oxidation products which are finally split into carbon dioxide and hydrogen. "Through our

researches," says the author, "we have determined that the respiration of cells both with and without chlorophyll is extraordinarily increased by alpha rays from the emanation."

Stoklasa, Pěnkava, and Barěs, in collaboration (82), refer to the foregoing experimental results, and note that these results clearly indicate a definite relation between the effect of the radiation and the concentration of hydrogen. The stronger the emanation is, the more hydrogen is necessary for the dissimilation process to proceed normally. The alpha rays increase the whole enzymatic process if hydrogen is present in suitable amount.

The authors state that their hypothesis of a coordinate substitution, rearrangement, and displacement under the influence of the physiological action of the rays of radioactive substances locates these coordinative alterations in the structure of the cell colloids, *vs.* the increase of the translative motion of the molecules. Just as the radiant energy of sunlight can transform the nonactive coordination of inorganic and organic compounds into a physiologically effective one, so also may the rays of radioactive substances bring about these changes.

Just as iron, say the authors, acts in its role as a catalyzer of the oxidation of the organism only in its physiologically active form, so is the power given to increase the whole physiological activity of the colloid particles of the cell, through the substitutions and rearrangements in their structure which are called forth by the beta rays which, in consequence of the physiological balance of the organism, accelerate the reduction processes. The result of the influence of the alpha rays is a derangement of the physiological balance in favor of the oxidation processes. If a radioactive element is directly attached to the surface of a colloid particle, the physiological process which accompanies the radioactive beta transformation produces a great labilization in the component parts of the cell and thereby strengthens the physiological effect of the beta radiation. Without such a strengthening—for example, when the beta rays enter the organism from without—the number of the beta particles must be incomparably greater in order to call forth the same physiological effect.

In the gamma irradiation a great resemblance of the photoelectric effect on mineral catalyzers (notably on iron, the catalyzer of oxidation) is combined with the effect of the secondary beta rays on the activity of the colloid particles. As a result, under gamma irradiation the balance of physiological processes is upset simultaneously by two antagonistic processes and the results, in consequence of the balance of oxidative and reducing processes, are not so unequivocal as with alpha and beta irradiations.

Ingber (38) exposed pure cultures of *Actinomyces bovis* to a dose of 10,575 mg./hr. of mesothorium. The rate of growth was retarded, but

after the removal of the source of radiation, the fungus resumed its normal rate of growth.

That photosynthesis may be stimulated by beta and gamma rays was also reported by Stoklasa (80). Cucumber plants whose leaves were treated yielded, in his tests, 1243 gm. as compared to 689 gm. for the control plants. Exposed mint and tobacco plants weighed 527 and 684 gm., respectively, as compared with 396 and 316 gm. for the controls.

Chondriosomes were found to be more resistant to beta and gamma rays than the nucleus, according to Milovidov (51). In roots of *Pisum sativum*, irradiated for 0.5 to 2 hr., there were irregular mitoses, but the chondriosomes appeared to be normal. After exposure for 5 to 6 hr. many mitochondria appeared much swollen, but others were not altered.

In 1930, Milovidov reported experiments confirming his earlier results and showing, besides, that the elements of the chondriosome in *Saprolegnia*, which appear inactive, are very resistant to the beta and gamma rays, showing no change after an irradiation for 5 hr. or more to rays from 5 mg. of radium chloride contained in a sealed glass tube. They behave quite like the mitochondria of the higher plants.

Feichtinger (24) analyzed the action of alpha and beta rays by using polonium and radium on rootlets of *Crepis virens*. The alpha rays produced injury to a depth of 30μ ; the tissues lying deeper than that appeared normal. The beta rays damage the tissues throughout the entire diameter of the root, owing to their greater penetrability.

In 1930, Stoklasa (83) and four collaborators review a great deal of the previously published work, and give an extensive bibliography. They discuss the effects of exposing seeds to beta rays only, beta and gamma rays together, and pure gamma rays. From their own experiments, they conclude that 18 to 24 hr. is the most favorable duration of exposure of seeds. A longer exposure to either beta, beta and gamma, or pure gamma rays is injurious. When seeds are exposed to high concentration of the emanation, the result is injurious to germination. The toxic effect of strong radioactivity on the seeds of forest trees is increased by ultra-violet light. When the radioactivity is of the strength 50,000 to 150,000 ME, the germination of seeds of *Pisum sativum*, *Pisum arvense*, *Lupinus angustifolius*, *Vicia Faba*, and others is stimulated. At 200,000 ME the intensity of germination is somewhat diminished and increasingly with increase in the strength of the radiation. At 500,000 ME the germination of some seeds (e.g., *Trifolium pratense* and *Hordeum distichum*) is completely inhibited and the embryo killed. Forest seeds appear to be more resistant than others. Other experiments prove that the photosynthetic processes are favored by beta and gamma rays together and by pure gamma rays; the elaboration of new living-plant substances is also favored.

Ingber (39), studying *Vicia Faba* var. *minor*, reported stimulation of function and also lesions. The second of two papers contains a review of the present (1931) state of radiobiology and a bibliography of 16 pages. In the same year, Kessler and Schanderl (40) reported on studies of the effect of rays of different intensities.

Montet (55, 55a, 56) reported on the effect of weak radioactivity on germination, and of radium rays on the germination of bulbs. With the bulbs the foliage was stronger and greener, the flowers were larger, and their color was more vivid.

Zirkle (88) studied the effect of the rays from Polonium (radium-F) on cells. The rays given off by the material used were only alpha rays. It was found that these rays retard and inhibit three distinct processes in the germination of the spores of *Pteris longifolia*, viz.: cracking of the sporewall; development of chlorophyll; and cell division. Extranuclear irradiation produced a high frequency of a type of induced twinning. This paper has a bibliography of related papers.

Doubtless the most exhaustive publication on the effect of radium rays on plant life since 1908 is the treatise by Stoklasa and Pěnkava (81). This contains bibliographies covering the entire subject from the first experiments, and is an indispensable handbook for those engaged in investigating this subject.

For the readers' convenience, papers dealing with the effect of radium rays on heredity are grouped together in the following paragraphs.

At the 1926 meeting of the Botanical Society of America, Gager and Blakeslee reported on experiments in subjecting germ cells of *Datura* to radium rays, and their paper appeared in February of the following year (26a) giving data concerning the appearance of both chromosome and gene mutations in that genus. The material exposed consisted of pedigreed plants in the cultures of Dr. Blakeslee at Cold Spring Harbor, Long Island. In the formation of one of the new forms ("Nubbin") that resulted from the radium treatment, there occurred a breaking up and reattachment of parts of nonhomologous chromosomes. The treatment was effected by inserting capillary tubes of radium emanation into the cells (compartments) of the ovary, or into the walls between the ovary cells. In one experiment the radiation had a strength of 13 millicuries, and the time of exposure was 10 min. At the time of treatment reduction had certainly already taken place in the pollen mother cells and almost certainly also in the megaspore mother cells. Seeds from the four ovary cells were kept separate in the sowing. The number of mutants varied from 11.54 per cent in seeds from one cell to 28.57 per cent in seeds from the cell into which the emanation tube was inserted. The chromosomal types resulting were mostly $2n + 1$ forms. Cell 1 gave rise to one $2n + 2$ type, called "Globe," and also to "Nubbin" mentioned above.

A percentage of 17.7 chromosomal mutants in over 100 offspring from a single capsule was greater than had been obtained even without the radium treatment. The average number of mutant forms ($2n + 1$) previously arising in a total of 15,417 progeny of untreated normal diploid parents was 73, or 0.47 per cent. These figures were interpreted as warranting the conclusion that the increased percentage of chromosomal mutations was due to the radium rays.

From one treated parent, two recessive gene mutations appeared in the offspring of 18 F_1 plants tested by selfing.

Radiation experiments with *Datura* have been continued by Buchholz, Blakeslee and collaborators and the results of treatment were reported in 1928 and later. The parts treated were pollen grains, pollen tubes, and seeds. Radium, radium emanation, and X-rays all produced genetic effects which may be classified under, (A) gene mutations; and (B) chromosome mutations.

A. Buchholz reported the production of three types of genes which affect pollen-tube growth in heterozygous plants: (a) those which cause the failure of half the pollen grains to germinate; (b) those which cause the early bursting of half the pollen tubes; and (c) those which cause a slower growth of half the tubes, thus forming a second mode of distribution in the style. These genes are transmitted through the egg cells, and in the F_2 generation segregation occurs in a 1:1 ratio in respect to normals and plants with the pollen abnormality.

Cartledge and Blakeslee (16) found genes which are transmitted through the eggs, but which cause the abortion of the pollen grains affected (8 cases), and about a dozen other genes which affect pollen form or behavior.

Avery and Blakeslee (3) found visible gene mutations of various kinds including 18 albinos, 13 pales, 8 with rough leaves, and 4 male steriles.

B. Bergner, Satina, and Potter reported frequent chromosomal abnormalities, including: (a) segmental interchange between chromosomes; (b) exchange of terminal humps (probably satellites) on chromosomes; (c) simple translocations resulting from fragmentation of a chromosome, one part of which is left as a free fragment, and the other part of which is permanently united to a nonhomologous chromosome; and (d) deficiencies of a whole or part of a chromosome.

Races homozygous for modified chromosomes have been called "prime types." Seventy-five prime types have been isolated from radiated *Daturae*, in 48 of which one or both of the modified chromosomes have been identified. Modified chromosomes from these prime types have been used in synthesizing "compensating types." The latter are plants which have only a single member instead of a pair of a particular chromosome, but in which the missing chromosome is compensated for by parts of two modified chromosomes. In the compensating type,

Nubbin, the formula of which is $2n - 1.2 + 1.9 + 2.5$, parts of the 1.9 and 2.5 chromosomes compensate to make the equivalent of the missing 1.2 chromosome, leaving the .9 and the .5 portions as extra chromosomal material responsible for the peculiarities of the type. Compensating types have been reported for 8 of the 12 chromosomes of *Datura*.

Three pure-breeding types, synthesized with chromosomes which had been modified by radiation, have been reported in *Datura*. Their formulae are as follows:

1. $2n - (11.12)_2 + (2.11.12)_2$
2. $2n - (1.2)_2 + (.1)_2 + (2.2)_2$
3. $2n - (13.14)_2 - (23.24)_2 + (2.14)_2 + (13.23)_2 + (.24)_2$

All three types are similar in appearance since they have excess .2 material; they breed true since the excess material is attached to an essential chromosome.

Stadler (71) described experiments showing that mutations may be induced in barley by radium rays, as well as by X-rays, which he had previously demonstrated. The source of the rays was 50 mg. of radium sulfate sealed in a thin glass tube within a tube of silver 1 mm. thick. Barley seeds, germinating in stacked watch glasses, were exposed continuously for 12 to 24 hr., at distances ranging from 1.5 to 11 cm. "The maximum dose (applied to seeds immediately above and below that containing the radium tube) was well below the limit of tolerance." Out of a total of 1039 exposed seeds, 3 "mutants" were reported; out of a total of 1341 control seedlings (unexposed), no mutants.

The following year, Goodspeed (28) showed that abnormalities of cytological behavior, external morphology, and fertility may be induced in various species of *Nicotiana* by exposure to radium rays as well as X-rays. "Heritable, qualitative alterations" of various kinds followed treatment of the sex cells of *N. Tabacum*. Lethality was conspicuous, and both dominant and recessive changes in vegetative and floral characters were found. The paper deals chiefly with the effects of X-ray treatment.

Later, Goodspeed (29) reported the occurrence in *Nicotiana* progenies from X-rays and radium treatments of three instances of apparent gene alteration, which he called "recessive monogenic mutations," namely, pink flower color, pistillody of the androecium, and albino seedlings.

In 1930 Constatin (20) presented a summary of studies of the genetical effects of radium rays and X-rays, also an extended bibliography.

Brittingham (12) studied the effect of rays from radon (emanation) on germ cells of *Oenothera Lamarckiana* and *Oe. franciscana*. An unfiltered tube of radon was inserted in a flower cluster parallel with the flower buds, thus exposing all the buds of the cluster at distances varying from direct contact to 4 cm. As the flowers opened after treatment they were

self-pollinated. A necrotic area developed in the inflorescence where the tube rested. The rate of flowering, size of the flowers, and "the fertility, chiefly of the pollen," were affected more or less according to the dosage. The percentage of germination was lowered for seeds in exposed capsules, and morphological abnormalities appeared in the resulting seedlings. Most of the atypical forms were too weak to survive field conditions. One of the abnormal types, of *Lamarckiana*, when selfed, gave a progeny in which the parent type composes approximately one-fourth (7 in 27) of the population. When one of the abnormal plants from *Oe. franciscana* was selfed, an entirely new form appeared, extremely weak and with very linear mottled leaves. This form was not viable under field conditions.

In one of his early papers on mutation, de Vries noted that, if the chromatin in reproductive cells could be altered by some external agent, artificial mutation might be produced. He suggested that, by skillful manipulation, this might be accomplished by bringing the sun's heat to a focus on a nucleus by means of a burning glass. That experiment appears never to have been successfully carried out, but the discovery of such penetrating radiation as that given off by radium placed a convenient device in the hands of experimental biologists.

Koernicke (41) was perhaps the first botanist to perform this experiment, using the pollen mother cells of *Lilium Martagon*. Within 20 hr. after a 5-hr. exposure to radium rays the chromatin thread of the nuclei of these cells was found to be broken up into double segments, much smaller and more numerous than in normal, unexposed cells. Other abnormalities were also figured, including the lagging behind and dropping out of chromosomes during their passage to the daughter nuclei during division.

Experiments on cell-division in the root-tips of *Allium cepa*, reported by Gager (25), included results similar to those of Koernicke. In some cases, small masses of chromatin became stranded, so to speak, on one side of the main nuclear spindle and organized a distinctly separate spindle, resulting finally in two subsidiary daughter nuclei. In some cases, the nuclei assumed amoeboid shapes, quite unlike anything seen in normal, unexposed nuclei.

The problem was investigated later by Opperman (60), who used trout eggs fertilized with exposed sperms and reported results essentially similar to those obtained by Gager and by Koernicke. These results naturally suggested experiments for the purpose of ascertaining whether true mutations may be produced by exposing germ cells to the action of radium rays.

At the meeting of the Deutsche Gesellschaft für Vererbungswissenschaft in August, 1921, Stein exhibited living plants, herbarium material, and photographs to illustrate the effect of exposure to radium rays on

Antirrhinum. Along with normal individuals there was shown a series of plants grown from seeds that had been exposed to the rays in 1918 and 1919. They were described as vegetatively persistent (*vegetativ-hartnäckige*) if not constant types. They were designated, "Radiomorphs" (*Radiomorphosen*). The variations included habitus, color, and form of leaves, form and color of flowers, and reproductive organs, the latter being sterile throughout. Alterations of leaf form by irradiation of the vegetative points were shown by photographs.

In the work of Stein (72) the material consisted of pedigreed plants from cultures of Dr. E. Bauer. Seeds of these plants were exposed to the rays and then planted. A number of abnormal types appeared, such as dwarfs, small eutimized leaved plants, and plants abnormal in form and color. In the small-leaved forms nondisjunction of the chromosome pairs was frequently observed in the reduction division. Other irregularities of mitosis in the formation of pollen grains are described. She finally states that the cause of the appearance of radiomorphs is not in the chromosome relations; it must be plastic substances which have undergone alteration and from which an embodiment (*Verkörperung*) of this alteration results. But the nature of this alteration is not thereby fathomed. We can see how it works out, but we do not know in what it consists.

Radiomorphs of different phenotype have certain characters in common, such, for example, as enlarged palisade cells. Their somatic tissue has the normal chromosome number. By somatic reversion branches arise which look normal, but their flowers retain the sterility characteristic of the radiomorphs. They have produced some mutants. In no case have offspring inherited the configuration of the radiomorphs. In Stein's own abstract of her 1927 work (*Biol. Abst.*, 1930, transl. by G. L. Fick), she states that "there is no positive proof that the chromosomes themselves are changed by irradiation."

In a later paper, Stein (73) described experiments in which plants in early embryonic stages were subjected to radium treatment, resulting in induced somatic gene mutations, of the nature of carcinomas, in localized regions. Germ cells descended from tissue containing the altered genes gave rise to an F_1 generation which had an inherited tendency to plant carcinoma. In the F_1 and F_2 generations, however, lesions occurred in any part of the body, while in the parental plants they occurred only in tissues derived directly from regions of the embryo in which the gene mutation had been induced. She interprets this not as a case of the inheritance of acquired characters but of the inheritance of gene mutations induced in somatic tissue. The material was *Antirrhinum majus*. A more extended account of further experiments on the inheritance of plant carcinomas in the same genus is also given by Stein (75). Here she states that the heredity of these abnormalities has a chromosomal

basis. These "phytocarcinomas" are similar to tumors in animals and in man. (For a further report see also Stein, 74.)

REFERENCES

1. ACQUA, CAMILLO. Sull azione dei raggi del radio nei vegetali. *Ann. Bot.* [Rome] **8**: 223-238. 1910.
2. AGULHON, H., and THÉRÈSE ROBERT. The action of radium and radioactivity on germination in the higher plants. *Ann. Inst. Pasteur* **29**: 261-273. 1915.
3. AVERY, A. G., and A. F. BLAKESLEE. Visible gene mutations in radium-treated and control material. *Anat. Rec.* **41**: 99. 1928.
4. BERGNER, A. DOROTHY, SOPHIA SATINA, A. G. AVERY, and A. F. BLAKESLEE. Translocated Sugarloaf, a pure breeding chromosomal type in *Datura* induced by radium treatment. *Science* **70**: 562. 1929.
5. BERGNER, A. DOROTHY, SOPHIA SATINA, and A. F. BLAKESLEE. Chromosomal abnormalities in F_1 's from radium-treated parents. *Anat. Rec.* **41**: 99. 1928.
6. BERGNER, A. DOROTHY, SOPHIA SATINA, and A. F. BLAKESLEE. Prime types in *Datura*. *Proc. Nation. Acad. Sci.* **19**: 103-115. 1933.
7. BLAAUW, A. H., and W. VAN HEYNINGEN. The radium-growth-response of one cell. *Proc. Roy. Acad. Amsterdam* **28**: 403-417. 1925.
8. BLAKESLEE, A. F. (Quoted in Year Books, Carnegie Institution of Washington, 1928-1932.)
9. BLAKESLEE, A. F., A. DOROTHY BERGNER, and A. G. AVERY. Compensating extrachromosomal types in *Datura* and their use as testers. *Science* **71**: 516. 1930.
10. BLAKESLEE, A. F., A. DOROTHY BERGNER, and A. G. AVERY. Methods of synthesizing pure-breeding types in the Jimson weed, *Datura stramonium*. *Proc. Nation. Acad. Sci.* **19**: 115-122. 1933.
11. BLAKESLEE, A. F., SOPHIA SATINA, A. DOROTHY BERGNER, J. S. POTTER, and A. G. AVERY. F_1 's from radium-treated pollen. *Anat. Rec.* **47**: 383. 1930.
12. BRITTINGHAM, W. H. Variations in the evening primrose induced by radium. *Science* **74**: 463-464. 1931.
13. BUCHHOLZ, J. T., and A. F. BLAKESLEE. The identification and transmission of lethals of pollen-tube growth in F_1 's from radium-treated parents. *Anat. Rec.* **41**: 98. 1928.
14. BUCHHOLZ, J. T., and A. F. BLAKESLEE. The identification and transmission of lethals of pollen-tube growth in F_1 's from radium-treated parents. *Jour. Hered.* **21**: 119-129. 1930.
15. BUCHHOLZ, J. T., and A. F. BLAKESLEE. Pollen tube growth and seed production after radium treatment. *Anat. Rec.* **47**: 382. 1930.
16. CARTLEDGE, J. L., and A. F. BLAKESLEE. Pollen abortion in F_1 's from radium-treated parents. *Anat. Rec.* **41**: 98. 1928.
17. COLWELL, H. A., and S. RUSS. Radium, X-rays and the living cell. 2nd ed., 365 pp. G. Bell and Sons, Ltd.; London, 1924.
18. CONGDON, E. D. Die Beeinflussung des Wachstums von Samen durch β -strahlen. *Anz. Akad. Wiss. Wien.* **120**: 431-432. 1911.
19. CONGDON, E. D. A comparison of the alterations in the velocity of growth of certain seedlings through the action of rapid and slow electrons of the β rays of radium, also a comparison of the role of chemical make-up and of physical factors in determining these alterations. *Roux' Arch. Entwickl. Mech. Organ.* **34**: 267-280. 1912.
20. CONSTANTIN, J. Actualités biologiques. L'action du radium et des rayons X. *Ann. Sci. Nat. Bot.* [Paris] **12**: I-XX. 1930.

21. DOUMER, E. Radiumemanation und die Keimung der Samen. Beiblätter, VI. Internat. Kongress Allgem. und Ärztl. Elektrol. und Radiol. Prog., Oct. 1912.
22. FABRE, G. Alterations organiques et fonctionelles des organismes végétaux sous l'influence du radium. Compt. Rend. Soc. Biol. [Paris] **69**: 523-524. 1910.
23. FABRE, G. Effets de l'activation de l'atmosphère par l'émanation de radium sur la germination et la poussée de divers organismes végétaux. Compt. Rend. Soc. Biol. [Paris] **70**: 187-188. 1911. (*See also* Ibid. **70**: 419-420. 1911.)
24. FEICHTINGER, NORA. Ueber die Einwirkung von α und β Strahlen auf das Protoplasma. Naturwiss. **18**(12): 252-257. 1930.
25. GAGER, C. S. Effects of the rays of radium on plants. Mem. New York Botan. Gard. **4**: viii + 278. 1908.
26. GAGER, C. S. Present status of the problem of the effect of radium rays on plant life. Mem. New York Botan. Gard. **6**: 153-160. 1916.
- 26a. GAGER, C. S., and A. F. BLAKESLEE. Chromosome and gene mutations in *Datura* following exposure to radium rays. Proc. Nation. Acad. Sci. **13**: 75-79. 1927.
27. GERTZ, OTTO. Fysiologiska undersökningar öfver slägtet *Cuscuta*. Bot. Notiser No. 2, p. 65-80; No. 3, pp. 97-136. 1910.
28. GOODSPEED, T. H. Effects of X-rays and radium on species of the genus *Nicotiana*. Jour. Hered. **20**: 243-259. 1929.
29. GOODSPEED, T. H. Inheritance in *Nicotiana tabacum*. IX. Univ. California Pub. Bot. **11**: 285-298. 1930.
30. GUILLEMINOT, H. Mésure de la quantité de rayonnement (préliminaire à l'étude de l'action des radiations sur la germination des plantes). Assoc. Française Av. Sci. 1907: 389. 1907. (*See also* Ibid. 1907: 390. 1907.)
31. GUILLEMINOT, H. Nouveau quantitomètre pour rayons X. Compt. Rend. Acad. Sci. [Paris] **145**: 711-713. 1907. (*See also* Ibid. **145**: 789. 1907.)
32. GUILLEMINOT, H. Persistence de l'action des rayons X et des rayons du radium sur la graine à l'état de vie latente. Compt. Rend. Soc. Biol. [Paris] **68**: 309. 1910.
33. HÉBERT, A., and A. KLING. De l'influence des radiations du radium sur les fonctions chlorophyllienne et respiratoire chez les végétaux. Compt. Rend. Acad. Sci. [Paris] **149**: 230-232. 1909.
34. HERTWIG, G. Das Radiumexperiment in der Biologie. (Literarische Zusammenfassung). Strahlentherapie **11**: 821-850. 1920.
35. HERTWIG, PAULA. Partielle Keimesschädigungen durch Radium und Röntgenstrahlen. Handb. Vererbungswissenschaft **3**, C: 1-48. 1927.
36. HOPKINS, C. G., and W. H. SACHS. Radium as a fertilizer. Univ. of Illinois. Agr. Exp. Sta. Bull. **177**. 1915.
37. HOPKINS, C. G., and W. H. SACHS. Radium fertilizer in field tests. Science **41**: 732-735. 1915.
38. INGBER, EDMONDO. Ueber die Radiumsensibilität des *Actinomyces* pilzes. Strahlentherapie **28**: 581. 1928.
39. INGBER, E. Radioeccitazione e radiolesione. Ricerche eseguite sulla *Vicia faba* var. minor. Atti Ist. Bot. Univ. Pavia. Ser. 4, **2**: 111-116. 1931. (*See also* Ibid. **2**: 173-268. 1931.)
40. KESSLER, O. W., and H. SCHANDERL. Pflanzen unter dem Einfluss verschiedener Strahlungsintensitäten. Strahlentherapie **39**: 283-302. 1931.
41. KOERNICKE, M. Ueber die Wirkung von Röntgen- und Radiumstrahlen auf pflanzliche Gewebe und Zellen. Ber. Deut. Botan. Ges. **23**: 404-415. 1905.
42. KOL'TSOV, A. V., and L. I. KOL'TSOV. The influence of the ray energy of the radio-active elements and X-rays on the growth and development of plants.

- Zap. Leningrad. Selsk. Khoz. Inst. Mém. Inst. Agron. Leningrad. **3**: 254-269. 1926. (In Russian.)
43. KOTZAREFF, A., and R. CHODAT. De l'action exercée par l'émanation du radium sur les levures. *Compt. Rend. Phys. Hist. Nat. [Genève]* **40**: 36-39. 1923.
44. LEVIN, I., and M. LEVINE. The action of buried tubes of radium emanation on neoplasts in plants. *Jour. Cancer Res.* **7**: 163-170. 1922.
45. LEVINE, M. The effects of radium emanation on the crown gall tissue. *Amer. Jour. Roentgenol. and Rad. Ther.* **14**: 221-233. 1925.
46. LEVINE, M. The influence of radium emanation on the microsporogenesis of the lily. *Proc. Internat. Congress Plant Sci.* **1**: 271-297. 1929.
47. MEZZADROLI, G., and E. VARETON. Azione esercitata dal radio sulla germinazione dei semi. *Atti R. Accad. Naz. Lincei Rend. Cl. Sci. Fis. Mat. Nat.* **12**: 73-80. 1930.
48. MIESCHER, G. Untersuchungen über das Vorkommen wachstumsfördernder Wirkungen nach Radiumbestrahlung an menschenpathogenen Hyphomyzeten. *Fortschr. Geb. Röntgenstr.* **33**: 81-84. 1925.
49. MIKLAUZ, R., and V. ZAILER. Ueber die Einwirkung radioaktiver Substanzen auf das Pflanzenwachstum. *Zeitsch. Landw. Versuchsw. Oesterreich* **21**: 354-355. 1918.
50. MILOVIDOV, P. F. Sur l'influence du radium sur le chondriome des végétaux inférieurs. *Protoplasma* **10**: 297-299. 1930.
51. MILOVIDOV, P. F. Vliv radiovyeh paprsků β a γ na chondriosomy rostlinné buňky. *Rozpravy České Akad. Véd. a Umění. Tř. 2.* **39**:(37): 1-10. 1929 (1930).
52. MOLISCH, H. Ueber den Einfluss von Radiumemanation auf die höhere Pflanze. *Sitzungsber. Kais. Akad. Wiss. Wien. Math.-Naturw. Kl.* **121**: 833-857. 1912. [See also *Ibid.* (a) **120**: 305-318. 1911; *Umschau* **17**: 95-98. 1913.]
53. MOLISCH, H. Das Treiben von Pflanzen mittels Radium. *Sitzungsber. Kais. Akad. Wiss. Wien. Math.-Naturw. Kl.* **121**: 121. 1912.
54. MOLISCH, H. Das Radium, ein Mittel zum Treiben der Pflanzen. *Naturwiss.* **2**: 104-106. 1914.
55. MONTET, D. Action des faibles radioactivités sur la germination des graines. *Compt. Rend. Acad. Sci. [Paris]* **194**: 304-306. 1932. [See also *Ibid.* (a) **194**: 1093-1095. 1932.]
56. MONTET, D. De l'influence des faibles radioactivités sur la germination. *Compt. Rend. Soc. Biol. [Paris]* **109**: 678-680. 1932.
57. NADSON, G. A. Ueber die Radiumwirkung auf die Hefezellen im Zusammenhang mit dem Problem des allgemeinen Einflusses des Radiums auf die lebendige Substanz. *Westnik. Röntgenol.-und Radiol.* **1**: 45-137. 1930. (In Russian.)
58. NADSON, G. A. Ueber die Wirkung des Radium auf die Hefepilze im Zusammenhang mit der Frage des Radiumeinflusses auf die lebende Substanz. *Ref. Fortschr. Geb. Röntgenstr.* **30**: 384. 1922-23.
59. NADSON, G. A. Sur l'accélération du temps de la vie et le vieillissement prématuré chez les organismes inférieurs sous l'influence des rayons X et du radium. *Compt. Rend. Soc. Biol. [Paris]* **93**: 1585-1586. 1925.
60. OPPERMANN, K. Die Entwicklung von Forelleneiern nach Befruchtung mit radiumbestrahlten Samenfäden. II. Theil. Das Verhalten des Radiumchromatins während der ersten Theilungsstadien. *Archiv. Mikros. Anat. Abt. 1.* **83**: 307-322. 1913.
61. PACKARD, C. Difference in the action of radium on green plants in the presence and absence of light. *Jour. Gen. Physiol.* **1**: 37-38. 1918.
62. PETIT, G., and R. ANCELIN. De l'influence de la radioactivité sur la germination. *Compt. Rend. Acad. Sci. [Paris]* **156**: 903-905. 1913.

63. PICHLER, F., and A. WÖBER. Bestrahlungsversuche mit ultra-violettem Licht, Röntgenstrahlen und Radium zur Bekämpfung von Pflanzenkrankheiten. *Centrabl. Bakt. Abt. 2.* **57**: 319-327. 1922.
64. PILZ, F. Radiumwirkung in Wasserkulturen. *Zeitsch. Landw. Versuchsw. Oesterreich* **19**: 399-410. Wien, 1916.
65. RAMSEY, R. R. Radium fertilizer. *Science* **42**: 219. 1915.
- 65a. REDFIELD, A. C., and ELIZABETH H. BRIGHT. The effects of radium rays on metabolism and growth in seeds. *Jour. Gen. Physiol.* **4**: 297-301. 1922.
66. RICHARDS, A. Recent studies on the biological effects of radioactivity. *Science* **42**, 287-300. 1915.
67. ROSS, W. H. The use of radioactive substances as fertilizers. U. S. Dept. Agric. Bull. 149. 1914.
68. ROUPPERT, C., and H. JEDRZEJOWSKI. Sur l'action du rayonnement des corps radioactifs sur les perules végétales. *Compt. Rend. Acad. Sci. [Paris]* **182**: 864-865. 1926.
69. RUSSELL, E. J. The effect of radium on the growth of plants. *Nature* **96**: 147-148. 1915.
70. SARTORY, A., R. SARTORY, and J. MEYER. Étude de l'action du radium sur l'*Aspergillus fumigatus* [sic] Frsenius en culture sur milieux dissociés et non dissociés. *Compt. Rend. Acad. Sci. [Paris]* **183**: 77-79. 1926. [See also *Ibid.* (a) **183**: 1360-1362. 1926.]
71. STADLER, L. J. Mutations in barley induced by X-rays and radium. *Science* **68**: 186-187. 1928.
72. STEIN, EMMY. Untersuchungen über die Radiomorphosen von Antirrhinum. *Zeitsch. Indukt. Abstamm. und Vererbungsl.* **43**: 1-87. 1926.
73. STEIN, EMMY. Weitere Mitteilung über die durch Radiumbestrahlung induzierten Gewebe-Entartungen in Antirrhinum (Phytocarcinome) und ihr erbliches Verhalten. *Biol. Zentralbl.* **50**: 129-158. 1920. (See also *Ibid.* **47**: 705-722. 1927; **49**: 112-126. 1929.)
74. STEIN, EMMY. Zur Entstehung und Vererbung der durch Radiumbestrahlung erzeugten Phytocarcinome. *Zeitsch. Indukt. Abstamm. und Vererbungsl.* **62**: 1-14. 1932.
75. STEIN, EMMY. Über den durch Radiumbestrahlung von Embryonen erzeugten erblichen Krankheitskomplex der Phytocarcinome von Antirrhinum majus. *Phytopath. Zeitsch.* **4**: 523-538. 1932.
76. STEIN, EMMY. Über vegetativ durch Radiumbestrahlung entstandene Periklinal-Chimären von Antirrhinum. *Zeitsch. Indukt. Abstamm. und Vererbungsl.* **64**: 77-94. 1933.
77. STOKLASA, J. Influence de la radioactivité sur le développement des plantes. *Compt. Rend. Acad. Sci. [Paris]* **155**: 1096-1098. 1912. [See also (a) *Ibid.* Kongresse Allgem. und Ärztl. Elektrol. und Radiol. Prag, Oct., 1912.]
78. STOKLASA, J. Bedeutung der Radioaktivität in der Physiologie. *Chem. Zeitsch.* **37**: 1176. 1913. Same title: *Oesterreich Chem. Zeitsch.* **16**: 323. 1913.
79. STOKLASA, J. Influence du sélénium et du radium sur la germination des grains. *Compt. Rend. Acad. Sci. [Paris]* **174**: 1075-1077. 1922. [See also *Ibid.* (a) **174**: 1256-1258. 1922.]
80. STOKLASA, J. Ueber die Verwendung der Radioaktivität im Gartenbau. *Gartenbauwiss.* **1**: 141-153. 1928.
81. STOKLASA, J., and J. PĚNKAVA. *Biologie des Radiums und Uraniums.* 972 pp. 152 figs. Paul Parey; Berlin, 1932.
82. STOKLASA, J., J. PĚNKAVA, and J. BARĚS. O působení radioaktivity na buňku chlorofylovou a buňku chlorofylu prostou. (The effect of radioactivity on cells with and without chlorophyll). *Sborník Československé Akademie Zemědělské.* **2**: 57-111. 1927. (In Czechoslovakian, with German and French summaries.)

83. STOKLASA, J., J. PĚNKAVA, M. ŠTRUPL, D. TJUKOV, and V. VRBENSKÝ. Die Dynamik der physiologischen Wirkung der Radioaktivität auf das Protoplasma. *Beitr. Biol. Pflanzen.* **18**: 185-224. 1930.
84. STOKLASA, J., J. ŠEBOR, and V. ZDOBŇICKÝ. Sur la synthèse des sucres par les émanations radioactives. *Compt. Rend. Acad. Sci. [Paris]* **156**: 646-648. 1913.
85. STUBBE, H. Untersuchungen über experimentelle Auslösung von Mutationen bei *Antirrhinum majus*. IV. *Zeitsch. Indukt. Abstamm. und Vererbungslehre.* **64**: 181-204. 1933.
86. SUTTON, H. F. (Radium and plant growth.) *Gard. Chron.* 3rd ser. **58**: 102. 1915. (Editorial summary of Sutton's report.)
87. WILLIAMS, MAUD. Some observations on the action of radium on certain plant cells. *Annals Bot.* **39**: 547-562. 1925.
88. ZIRKLE, R. E. Some effects of alpha radiation upon plant cells. *Jour. Cell. and Comp. Physiol.* **2**: 251-274. 1932.

Manuscript received by the editor October, 1933.

THE LIGHT FACTOR IN PHOTOSYNTHESIS

H. A. SPOEHR AND J. H. C. SMITH

*Carnegie Institution of Washington, Division of Plant
Biology, Stanford University, California*

The role of light in the formation of the chloroplast pigments: Chlorophyll—Carotenoids. The optical properties of leaves. Optical properties of the chloroplast pigments. Effect of light intensity in photosynthesis: Inhibition by high light intensities—Nutritional factors—Chemical inhibitors—Temperature—Light and internal factors; Water. Chlorophyll—Light intensity and morphological factors—Time effect in photosynthesis—Compensation points—The limits of light intensity utilizable in photosynthesis—Effect of wave-length on photosynthetic rates; Infra-red, visible, ultra-violet—Wave-length limits of photosynthesis. The mechanism of the photosynthetic reaction. The energy relations of photosynthesis: The apparent efficiency of the photosynthetic process—The real efficiency of the photosynthetic reaction—Energy transfer. Photosynthesis in bacteria: Purple sulfur bacteria. References.

In this survey the discussion is confined as closely as has been possible to those aspects of the phenomenon of photosynthesis which are primarily concerned with the influence of light. Of necessity, even such a restricted discussion involves a wide range of physical and chemical concepts and naturally demands some knowledge of fields which are ancillary to the central theme. It has obviously not been possible to give consideration to all the work which has been done in this field. This is especially true of the older publications. The aim has been to describe the present status of the subject with some consideration of the background offered by the older work. For a discussion of this reference is made to the following monographs: H. Schroeder, *Die Hypothesen über die chemischen Vorgänge bei der Kohlensäure-Assimilation und ihre Grundlagen*, Jena, 1917; J. Holluta, *Die neueren Anschauungen über die Dynamik und Energetik der Kohlensäureassimilation*, Stuttgart, 1926; W. Stiles, *Photosynthesis, The assimilation of carbon by green plants*, London, 1925; H. A. Spoehr, *Photosynthesis*, New York, 1926.

THE ROLE OF LIGHT IN THE FORMATION OF THE CHLOROPLAST PIGMENTS

CHLOROPHYLL

It is very generally agreed that chlorophyll is essential for photosynthesis. Although this fact has not been demonstrated with the complete certainty desirable for such an important conclusion, as yet no evidence has been presented contrary to the assumption that the plant

must contain some colored substance capable of absorbing visible light and that this role can be chiefly ascribed to chlorophyll. At the same time, a more intimate study of the other pigments of the chloroplasts and of the pigments of such plants which carry on photosynthesis with other pigments and a modified mechanism, *e.g.*, the sulfur bacteria (possibly survivors of another age), may contribute greatly to an understanding of principles involved.

Light is essential for the greening of most plants, but there are a number of other factors of equal importance, *viz.*, temperature, oxygen supply, available carbohydrates, mineral nutrients, and notably iron. The influence of the various factors has usually been studied singly. It is not improbable that they are intimately interrelated, and that in order to gain a more complete conception of the mechanism of chlorophyll formation, it will be necessary to consider the interrelation of the factors concerned. The complexity of the subject is further emphasized by results obtained from the extensive genetic studies of chlorophyll abnormalities (64, 64*a*). For the greening of virescent types Demerec (19) showed that temperature is quite as important a factor as light. The subject of chlorophyll formation is, of course, only ancillary to the main topic here being considered and we shall confine the discussion to a brief review of the influence of light in this process.

It has been realized for a long time (139) that all plants do not require light for the formation of chlorophyll, although the amount formed in the dark is usually very small as compared with that produced in the light (139, 71). Some conifers (11), ferns (99, page 159), mosses (121), and algae (3, 99, 41, page 442) have been observed to produce chlorophyll in the dark. Ordinarily exceedingly low intensities of light are sufficient to produce some chlorophyll in most plants. Now, it is known that in respiration, besides heat, some radiations are emitted as light. Although these are usually of short wave-length, may it not be possible that in those plants which form chlorophyll in the dark sufficient radiation is produced in this manner that the plant can form chlorophyll from its own internal bioluminescence? In fact, Kostytshew (55) quotes a Russian investigation to the effect that the intensity of bacterial light is sufficient to produce chlorophyll in etiolated plants.

Apparently light is not necessary for the maintenance of chlorophyll in all plants, for Dangeard (15) cultured *Scenedesmus acutus* on a nutrient solution containing 1 per cent of glucose for eight years in the dark without the loss of chlorophyll. At the end of this period the algae still possessed the capacity to do photosynthetic work when placed in the light, although profound morphological changes had occurred. It is interesting that with higher concentrations of organic material in the nutrient solution the chlorophyll disappears, an observation which has also been made by Pringsheim (91, page 8).

But most plants require light for the formation of chlorophyll and for this the wave-length of the light, its intensity, and the length of exposure are of significance. Much of the earlier investigation was done with methods which could yield only qualitative results. In fact, two rather distinct aspects must be considered, namely, it is necessary to differentiate between the formation of chlorophyll and its accumulation. In the first case one would be dealing with the appearance of the first traces of chlorophyll, and in this case the difficulties of accurately determining extremely small quantities of the pigment must be dealt with. In determinations involving the accumulation of chlorophyll consideration must also be given to the simultaneous decomposition of the pigment, which may occur under a variety of conditions; particularly in the sudden exposure of a plant to light of high intensity.

There is an extensive older literature dealing with the formation of chlorophyll in different portions of the spectrum (139). For this purpose use has been made of optical prisms, gratings, and filters (94), but insufficient regard has been paid to intensity and possible destructive action of light on the chlorophyll. The result of the total of this work is a rather confused picture and there are few points on which there is general agreement. The infra-red and extreme red end of the spectrum is apparently without benefit to chlorophyll formation (47). The orange-yellow rays have been generally regarded as the most effective in chlorophyll formation; also in this portion of the spectrum the destruction of the chlorophyll is most pronounced. Chlorophyll formation also occurs in the blue end of the spectrum, though it is not certain what the limit is in the violet region. There is as yet no agreement as to whether chlorophyll formation in different portions of the spectrum accords with the absorption spectrum of chlorophyll.

The complexity of the series of reactions involved in chlorophyll formation has been emphasized by almost everyone who has given the subject intensive study. It would appear that little is to be learned from a consideration of light only as a factor in this process. Of equal importance are the nutritive substrate in the cells containing the chloroplasts and the action of certain, as yet only imperfectly described, enzymes. Light may affect the general reaction of greening in various ways, directly through a photochemical reaction of some precursor of chlorophyll and indirectly through its influence on the permeability of the cells, thus affecting the nutrition of the plastid.

Several theories have been advanced in an effort to describe the chemical steps involved in chlorophyll formation, notably by Lubimenko (67, 68, 69, 70, 71), Noack (85), and Liro (65). Lubimenko strongly supports the contention that the chloroplast pigments are intimately bound to protein constituents of the plastids and consequently the formation of chlorophyll must also be dependent upon the protoplasmic activity

of the cell. It is, therefore, primarily the quantity of oxidizing enzymes and the intensity of oxidations which influence directly the accumulation of chlorophyll in the plastids.

The precursors of chlorophyll are considered to be colorless substances which in a series of steps are converted, apparently through oxidation, to the colored compounds. Unfortunately considerable confusion exists concerning the nomenclature of these hypothetical precursors of chlorophyll and clarification of the subject can probably not be attained until intensive chemical investigations on these substances have been completed comparable to those which have been made on chlorophyll itself. Some important results in this field have already been obtained by Noack and Kiessling (85). Lubimenko considers that chlorophyll arises in several steps: through catalytic oxidation of the colorless leucophyll there is formed chlorophyllogen, a pigment having an absorption spectrum resembling that of chlorophyll. In some of the algae, the young sporelings of ferns and bryophytes, and in some of the conifers chlorophyllogen is converted into chlorophyll without the action of light. Seedlings of angiosperms, in which the system of nourishing the embryo is more complex, require light for the formation of chlorophyll from chlorophyllogen. This reaction, according to Lubimenko, is most rapid in the red end of the spectrum, the blue rays are next in activity, while the green rays have little effect. Under the influence of various physical and chemical agents the cell proteins are precipitated and chlorophyllogen gives rise to another pigment, protochlorophyll, having an absorption spectrum in which the bands are displaced toward the violet as compared with chlorophyll. From the experiments of Lubimenko it seems probable that light also influences the enzymatic reactions which give rise to the formation of leucophyll and that light also induces the decomposition of chlorophyll already accumulated. As a result of this extremely complex situation it is not surprising that it has been difficult to obtain concordant opinions, that every species seems to possess a different optimum light intensity for chlorophyll formation, and that this optimum varies with the age and previous treatment of the plant.

While Lubimenko and also Liro consider that protochlorophyll is of the nature of a postmortal product of a chlorophyll precursor, Noack (85) regards protochlorophyll as the immediate precursor of chlorophyll. Lubimenko bases his conclusion on the fact that he could not identify the presence of the protochlorophyll absorption spectrum in living plants. Noack believes that this was due to the fact that the concentration of protochlorophyll in living leaves is exceedingly small. He claims to have obtained the characteristic red absorption band of protochlorophyll by means of special methods even in living leaves. But, he points out, the concentration of protochlorophyll in leaves is so very small that

it must be regarded in the light of an intermediate product which never accumulates to any great extent and itself arises from some other related compound. Noack and Kiessling (85) prepared sufficient quantities of protochlorophyll from the inner coats of the seeds of certain *Cucurbitaceae* to carry out physical and chemical investigations on it. The absorption bands of protochlorophyll in ether solution are reported by Scharfnagel (98) as follows: I. 6300 to 6150 Å, II. 6080 to 5950 Å, III. 5790 to 5600 Å, IV. 5300 to 5200 Å and in the following order of intensity: I, IV, III, II. The emission spectrum of the red fluorescence of protochlorophyll is shifted toward the violet: fluorescence of chlorophyll, 6850 to 6280 Å, of protochlorophyll 6570 to 6190 Å.

Through a series of chemical investigations Noack and Kiessling have established a relationship between protochlorophyll and chlorophyll *a*. They conclude that the latter is a product of photooxidation of the former. They found no evidence of two protochlorophylls corresponding to the *a* and *b* modification of chlorophyll. That the oxidation of protochlorophyll to chlorophyll occurs in the living leaves and not in leaves which have been killed was shown by Scharfnagel (98) who also found some indications that with illumination of high intensity the amount of chlorophyll formed from protochlorophyll is less than with light of moderate intensity.

By using the first appearance of the $\lambda 6650$ Å absorption band of chlorophyll as a criterion for the beginning of chlorophyll formation in etiolated *Zea Mays* seedlings, exposed to light passing through an assortment of filters, Schmidt (100) determined the influence of different wavelengths. Measurements were made of the time of exposure required for the first appearance of chlorophyll and these times were then calculated on the basis of equal intensities for the different filters. Maximum chlorophyll formation was found to occur in the orange, $\lambda 7100$ to 6100 Å, but falling off toward the red end of the spectrum; a minimum was found in the green and a secondary maximum in the blue. Light which had been filtered through an alcoholic chlorophyll solution was ineffective in producing chlorophyll. The superior effectiveness of the red rays is also shown in the investigations of Sayre (96) who, however, simply compared the relative greenness of the experimental plants with controls grown under all wave-lengths of light. From this work, in which light filters were used which, of course, do not yield monochromatic light, it would appear that the limit for chlorophyll formation in the red end of the spectrum is $\lambda 6800$ Å.

Attempts to determine the influence of light on chlorophyll accumulation under controlled environmental conditions have served to demonstrate the complexity of this reaction. They tend to confirm the conclusion formulated by Lubimenko (70), that maximum chlorophyll

formation occurs at a definite light intensity, that this varies with the species and age of plant, and that either above or below this intensity chlorophyll accumulation may decrease. Thus, Shirley (106) found that the chlorophyll concentration per unit leaf weight and unit leaf area of a variety of plants showed an increase with decreasing light intensities. Further decrease in light intensity resulted in a decrease in chlorophyll content. Leaves of different species vary widely in chlorophyll content, and sunflower, which has a relatively low content, showed relatively slight variations with light intensity, while hog peanut [*Amphicarpa monoica* (L.) Ell.], with a high content, showed large variations with different concentrations.

The effect of increasing the duration of illumination, by supplying supplementary electric light, is demonstrated by the experiments of Guthrie (36) and of Sjöberg (108). In Guthrie's experiments an increase in illumination (12 hr. daylight and 12 hr. electric light) resulted in a decrease in chlorophyll content. Reducing the light intensity to 12 per cent of normal sunlight resulted in an increase in chlorophyll. Provided the intensity was kept the same, elimination of blue light (by means of glass filters) resulted in a slight decrease in chlorophyll, while elimination of the red light caused a very slight increase, though this is not certain. Shirley's (106) results indicate that with light intensities of 10 per cent of full sunlight all of the five spectral regions used by him gave about the same chlorophyll concentrations, though the spectral region λ 5290 to 7200 Å usually gave lower values.

The experiments of Sjöberg demonstrate that during February and March the natural light intensity was not sufficient for maximal chlorophyll formation and even with supplementary illumination this value was not reached. As the natural illumination increased during April, supplementary illumination produced maximal chlorophyll content, until later in the year the artificial illumination had no effect. Sjöberg's experiments also demonstrate that a longer period of relatively low intensity illumination is more advantageous for pigment formation than a shorter period of high intensity. Thus *Brassica rapa*, using artificial illumination during periods of 4, 6, 9¹/₄, 13¹/₃, and 24 hr. with equal total intensities for all the periods, showed maximal pigment formation when illuminated for 9 to 13 hr. each day.

Owing to inherent complications in the methods of separation and analysis, it is extremely difficult to arrive at thoroughly valid conclusions concerning the possible changes in the two chlorophyll components under different environmental conditions. Guthrie (36) has obtained some evidence that the *a:b* ratio is lowered by the elimination of blue light. This was also found to be the case in tomato plants which were exposed to continuous artificial illumination. The conclusions of Wlodek (146) that the intensity of the illumination causes a change in the *a:b* coefficient

are subject to the uncertainties of determining the concentration of the two components by spectroscopic examination of the living leaves.¹

When we turn to the question of the chlorophyll content of plants under natural conditions, a much more complicated condition is encountered. Willstätter and Stoll (143) found that the content of chlorophyll and the ratio of the two components did not change during long periods of photosynthesis even under conditions of high activity. This, however, was under laboratory conditions, and they themselves point out (143, page 40) that it is conceivable that under conditions of excessive illumination chlorophyll may be decomposed. As a matter of fact, fluctuations in the chlorophyll content of plants growing under natural conditions have been observed. Variations as high as 30 per cent in 24 hr. have been reported by Henrici (42, 43) occurring on sunny days in Bechuana-land grasses. The decreases occur from early morning to midday and the increases during the ensuing night, both depending upon the complex of meteorological conditions. The chlorophyll content also varies during the course of the year, being high in the young leaves, decreasing with the intensity of the drought periods, and increasing after the rains. There are also differences from year to year. Similarly, Stålfelt (113) has reported decided fluctuations during the course of the year, in the chlorophyll content of *Pinus silvestris* and *Picea excelsa* growing near Stockholm, though no correlations could be established between these fluctuations and light intensities or temperatures. On the other hand, in the experiments of Sjöberg (108), also carried out near Stockholm under natural conditions, but with *Vicia Faba* and *Tropaeolum majus*, the variations of chlorophyll content were such that the high values coincided in general with periods of high light intensity and vice versa. It is evident that a great deal more investigation is required in which light intensities (both total and of different spectral regions) are measured and also other factors, such as leaf temperatures, must be considered in order to arrive at conclusions of more general validity.

CAROTENOIDS

The carotenoid pigments, carotene and xanthophyll, have been found always to accompany chlorophyll in organs capable of photosynthesis. The role of these orange-yellow pigments in the photosynthetic process is as yet not known; in fact, it is not certain that they play a direct part and opinions on this are still at variance. In general, there have been two schools concerning the possible function of the carotenoid pigments in photosynthesis: the one ascribes a purely chemical role to them, the other places chief emphasis on their optical properties. Whether either

¹ It may not be amiss to state here that the nomenclature of the chlorophyll components, as nearly as they are comparable, is as follows: Chlorophyll *a* (Willstätter) = neochlorophyll (Marchlewski) = chlorophyll α (Tswett); and chlorophyll *b* (Willstätter) = allochlorophyll (Marchlewski) = chlorophyll β (Tswett). (Cf. 46.)

one of these will lead to the correct answer or some other explanation of their role will be found will in all probability depend upon further investigation of their chemical composition and their physical and chemical properties.

As in the case of chlorophyll, no simple, definite statement can be made concerning the influence of light on the formation of these pigments. The extensive older literature has been well reviewed by Kohl (54) and the more recent methods of estimation by Deleano and Dick (18). The fundamental difficulty in the problem is that until recently there have not been reliable methods for the separation of the various leaf pigments and their accurate determination. Even at the present time, with modern spectrometric apparatus, the task is associated with difficulties and pitfalls which reveal themselves only after considerable experience. If the pigment has not been isolated in pure form, the depth of color of a solution can very rarely be taken as a measure of its concentration.

The presence of xanthophyll in etiolated seedlings has been established by Euler and Hellström (27) and by Sjöberg (108). From their results it is also apparent that the amount of this pigment is increased through the action of light. In etiolated barley Euler and Hellström (27) could not detect any carotene with the exception of a few cases in which traces of chlorophyll were also found. On illumination, the carotene was found to increase appreciably. On the other hand, Sjöberg found distinct yellow coloration, due to carotene and xanthophyll, in the etiolated tips of the leaves of oats, though the latter pigment was present in relatively much larger quantity than the former. The amounts were decidedly increased by exposure to light. He also was able to detect traces of carotene in the tips of etiolated seedlings of cress. It is just possible that differences of temperature at which the seeds are sprouted may account for these variable results. Sjöberg found that the etiolated shoots of plants with storage organs contain both carotene and xanthophyll and that the amounts they contain are increased by exposure to light. As was the case in the experiments of Guthrie (36) with chlorophyll, long periods of illumination decreased the amounts of carotenoids in both soy beans and tomatoes. When plants were placed in the dark the chlorophyll content decreased, but the carotenoids did not show a parallel decrease. On the basis of the similarity in composition of carotene and phytol the possibility of a genetic relationship between carotene and chlorophyll was considered by Willstätter and Mieg (141) and by Smith (109), and this has received some experimental support by Rudolph (95).

THE OPTICAL PROPERTIES OF LEAVES

The light which falls upon a leaf is in part reflected by it, in part absorbed by the materials of the leaf, and is in part transmitted through

it. In any consideration of the role of light in photosynthesis the optical properties of the chlorophyll-bearing organ is of great importance, especially if any information regarding quantitative relationships is to be gained. Advance in this problem has been greatly aided by the application of recent developments in physical and optical apparatus for the measurement of light and of useful artificial sources of light. Helpful compilations of the theory and use of the methods and apparatus for work in this field, with special application to plant physiological problems, have been prepared by Nuernbergk (86) and by Gaffron (30). Space does not permit discussion of this important aspect of the experimental treatment of the problems concerned. This subject is treated in another section of this report to which reference must be made and to the works just cited. The older literature has been reviewed by Ursprung (122), and a compilation of transmission data of a large variety of leaves has been made by Schanderl and Kaempfert (97).

A not insignificant portion of the light falling on a leaf is reflected from its surface. The quantity depends, of course, upon the angle of incidence of the light, and also upon the texture of the leaf surface, its age, and the spectral composition of the light. In the leaves of land plants reflection occurs at the outer surface and also within the leaf, at the surfaces of the intercellular spaces, in fact, wherever the light strikes an interface of material of different refractive index. The leaves of land plants, therefore, offer a very complex system; this may be somewhat simpler in the case of aquatics.

In the spectrophotometric measurements of Pokrowski (90) and of Shull (107) the percentage of 90 deg. reflection of light from the upper surface of a variety of leaves of trees and herbaceous plants was found to vary from about 3 to 15 per cent. From green leaves the amount of reflection is maximum for light of $\lambda 5400$ to 5600 \AA . In this region the reflection is 5 to 10 per cent in the darkest green leaves and 20 to 25 per cent in the lightest green foliage. A reflection minimum has been observed at the maximum absorption band of chlorophyll, $\lambda 6600$ to 6800 \AA , though this is not always the case. Albino leaves reflect very much more light than green ones, amounting to 40 to 50 per cent and these reflect mainly the radiations of longer wave-length. The under surface of leaves reflects more light than the upper surface, though the values for different wave-lengths run about parallel. It is interesting that hairiness or smoothness of the cuticle does not regularly result in high reflection. The extensive investigations of Seybold (104, *a, b, c*) on the basis of energy measurements, in the main, confirm the results of Pokrowski and of Shull. Seybold has made a thorough study of the complex system which the green leaf presents as an absorbing and reflecting medium. The order of magnitude of the values for reflection of a parallel beam of light falling on a leaf and for diffuse light is the same. In

Table 1 are given mean relative values of the reflection of diffuse daylight obtained by Seybold (104b).

TABLE 1.—RELATIVE VALUES OF THE REFLECTION OF DIFFUSE WHITE LIGHT
Per Cent

Magnesium oxide.....	100
<i>Aesculus Hippocastanum</i>	
White-leaf surface.....	36
Green-leaf surface.....	10
<i>Pelargonium zonale</i>	
White-leaf surface.....	38
Green-leaf surface.....	16
<i>Syringa vulgaris</i>	14
<i>Polygonatum sachalinense</i>	14
<i>Acer pseudoplatanus</i>	11
Soot.....	4

The epidermis of leaves, particularly if this is heavily cutinized or covered with wax, as in xerophytes, affects the light which enters the parenchyma. Such cuticular layers have an effect similar to a sheet of parchment, so that the light reaching the chloroplasts is diffuse. Some light is also absorbed by these layers; in shade plants this is very small, but in alpine and desert plants the transmission may be as low as 15 to 25 per cent, according to Schanderl and Kaempfert (97).

For almost 30 years the values for the amount of radiant energy which is absorbed by green leaves as determined by Brown and Escombe (9) have been used in investigations on the energy relations of photosynthesis. They found that 65 to 77 per cent of the incident radiant energy was absorbed by the various leaves which they studied. Recently these determinations have been superseded by more accurate measurements made possible through the development of modern light-measuring apparatus and optical equipment, and in which some factors neglected in the older determinations, chiefly reflection, have been considered. The values for absorption have usually been obtained on the basis of the transmission and reflection of light. These values were expressed as absorption coefficients, but more recently in terms of per cent of the incident light absorbed:

$$\text{Absorption} = 100 - (\text{transmission} + \text{reflection})$$

Earlier determinations were made with sunlight, because of the desire to approach "natural" conditions. They possess the uncertainties associated with this source of illumination, owing to irregularities in intensity and spectral composition. For obvious reasons it is desirable to know the absorption by the leaf of different wave-lengths or portions of the spectrum and this can be more easily obtained with artificial sources than with sunlight.

The determination of the absorption spectra of a variety of green leaves has yielded results which are in general very much alike (4, 26, 26a,

67, 90, 93, 104c, 124). Maximum absorption appears in the red and in the blue-violet regions of the spectrum and maximum transmission in the green. The spectrum is composed of several bands, the maxima of these as reported by Willstätter and Stoll (143) for *Sambucus nigra* at about $\lambda 6750$, 6240 , 5850 , 5430 \AA and an end absorption from $\lambda 5190 \text{ \AA}$. If the percentage absorption is plotted against wave-length, the bands of absorption are not nearly so distinct as the published spectrograms indicate, owing to "contrast bands" which appear in spectrograms and in visual observations. An absorption curve of *Sambucus nigra* as determined by Seybold (104c) is shown in Fig. 1. There is some difference of opinion concerning the variability of the absorption spectra of different leaves (Lasareff, 62). Lubimenko (67) is of the opinion that each leaf possesses its own transmission spectrum.

That variations in transmission spectra of leaves should exist seems inevitable. The transmission curves are dependent upon the physical structure of the leaves as well as upon their pigment content. Both of these properties differ to some degree in each individual leaf.

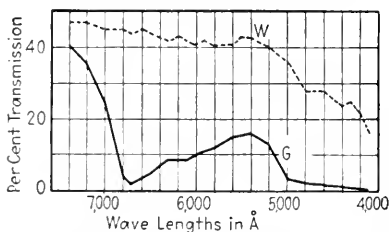

FIG. 2.—Transmission spectra of leaves, *Acer negundo*: W, white leaf; G, green leaf. (Seybold, 104c.)

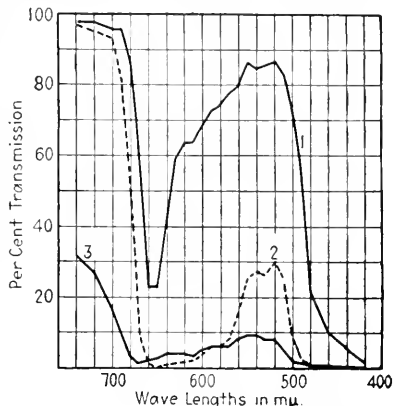

FIG. 1.—Comparative spectral transmission curves for: 1, dilute solution of chlorophyll in acetone; 2, concentrated solution of chlorophyll in acetone; 3, leaf, *Sambucus nigra*. (Seybold, 104c.)

Of primary importance is exact information regarding the proportion of light which is absorbed by the pigments of the leaf, especially those of the chloroplasts. A favorite method of arriving at this value has been through the comparison of the absorption of the pigmented leaf with that of an albino leaf of the same species. It is, however, not justifiable to assume that the amount of light which is absorbed by an unpigmented leaf is equal to the amount of light which is absorbed by the colorless portion of a similar leaf (Willstätter and Stoll, 143, page 120) (Seybold, 104a, b). The amount of light absorbed by the colorless substance in the pigmented leaf is, on a percentage basis, less than in the unpigmented leaf, because each volume unit within the green leaf receives less light energy than the corresponding volume unit of the white leaf. Also the reflection from the surface of an unpigmented leaf is much higher than from a pigmented one. In Table 2, are given the mean values

obtained by Seybold (104a) for determinations of the absorption of 10 species of white and green leaves. The wave-lengths of light given represent maximum transmission of the filters used. The results were in general confirmed by Seybold (104c) with the use of a monochromator (Fig. 2).

TABLE 2.—PERCENTAGE TRANSMISSION, REFLECTION, AND ABSORPTION OF LIGHT, MEAN VALUES OF 10 SPECIES OF LEAVES OBTAINED BY SEYBOLD

	White-leaf lamina					Green-leaf lamina				
	644	578	509	436	336	644	578	509	436	336
Wave-length, $m\mu$	644	578	509	436	336	644	578	509	436	336
Transmission.....	33	33	31	20	8	9	10	10	2	0
Reflection.....	46	47	43	27	18	13	14	14	11	9
Absorption.....	21	20	26	53	74	78	76	76	87	91
Absorption coefficients.....	0.21	0.20	0.26	0.53	0.74	0.78	0.76	0.76	0.87	0.91

The green leaves of *Pelargonium zonale*, on the basis of energy measurements, show two absorption maxima: at $\lambda 6700 \text{ \AA}$ and at 4800 to 4100 \AA and two absorption minima: at $\lambda 7300$ and 5400 \AA . Little is known regarding either absorption or reflection in wave-lengths longer than $\lambda 7400 \text{ \AA}$ and shorter than 4100 \AA . The absorption at the maxima is about 90 per cent of the incident light, and for the minima it is about 60 per cent at $\lambda 7300 \text{ \AA}$ and 74 per cent at $\lambda 5400 \text{ \AA}$.

The main absorption by the leaf must, of course, be ascribed to the pigments and this amounts to about 60 to 70 per cent, so that the distribution of energy can, according to Seybold, be placed as follows:

	Per Cent
Incident energy.....	100
Absorption of the colorless leaf substance.....	10
Reflection.....	10
Transmission.....	10
Absorption by the chloroplasts.....	70

Determinations with pigmented and colorless leaves indicate that the absorption values of both of these obey Lambert's law (104a). Seybold has calculated the thickness of the chloroplast layers in order to determine the number of these bodies through which a ray of light may pass successively. He found for *Tropaeolum majus* 7, *Phaseolus multiflorus* 5, *Ricinus communis* 9. A single chloroplast, it was found, absorbs about 30 per cent of the incident light, the second about 21 per cent, the third a further 15, the fourth 10 per cent, beyond that the percentage absorption is very little, so that it may be concluded that the number of chloroplasts in the layer beyond the fourth plays a relatively small role in the absorption of light. Transmission values are the same for a parallel beam of light and for diffuse light; there is no evidence that there is a Callier effect produced by the chloroplasts in a leaf (104b).

Of great significance for the absorption of light by the leaf is the phototaxis of the chloroplasts, whereby the amount of light absorbed by the leaf is modified. The factors affecting these movements are of a very complex nature; earlier work in this field has been well summarized by Senn (103) and recently Voerke (131) has studied the effect of different wave-lengths. Schanderl and Kaempfert (97) conclude that, due to the phototactic movements of the chloroplasts, the transmission of light by a leaf may be altered very materially within a short period; they observed increases in transmission of about 40 per cent within 10 to 40 min. This is particularly noticeable in the blue end of the spectrum. With the accumulation of the photosynthate, notably starch, the transmission of the leaf for light may also be considerably altered.

All of these facts serve to emphasize that leaves or other chlorophyll bearing organs present an exceedingly complex optical system and that, although the absorption of light by the pigments is of primary importance for photosynthesis, there are many factors which make quantitative measurements of this very difficult. Consequently, attempts to estimate the amount of light absorbed by the pigments in the leaf through methods based upon the extraction of the pigments and the determination of the absorption of these solutions, can give only approximations which are usually low (104c).

Much attention has been given to the question as to which spectral regions are effective in photosynthesis. The results depend to a considerable degree upon the methods which have been used.² However, there is general agreement that the greatest photosynthetic activity in green plants is in the red portion of the spectrum, corresponding to the greater absorption of light in that region. The existence of a second maximum in the blue-violet region, corresponding to the absorption of the pigments in this region (26, 26a, 51, 53) has not been found by some other workers (21, 124, 134). The lower activity in the blue-violet region has been ascribed to the increased scattering of the light and to the absorption thereof by the yellow pigments. The problem is in need of accurate quantitative work with monochromatic light of various wave-lengths and controlled incident intensity.

OPTICAL PROPERTIES OF THE CHLOROPLAST PIGMENTS

The utilization of light in photosynthesis is dependent upon its absorption by the pigments in the plant. In most plants the pigments which are directly involved in this process are located in the chloroplasts, although the exact structure of these organs and the relationships of the pigments and colorless portions thereof are not clearly understood as yet.

² Englemann (26, 26a) used the motile bacteria method; Kniep and Minder (53) the bubble counting method; Ursprung (124) the formation of starch; Warburg (134) the manometric method; Ehrke (21) the Winkler method for dissolved oxygen; Klugh (51) the indicator method for changes in alkalinity.

Of primary importance is the question as to what pigments are of significance for the photosynthetic reaction. This question can be partially answered by a comparison of the absorption spectra of the photosynthetic organs and of the pigments themselves with the photosynthetic

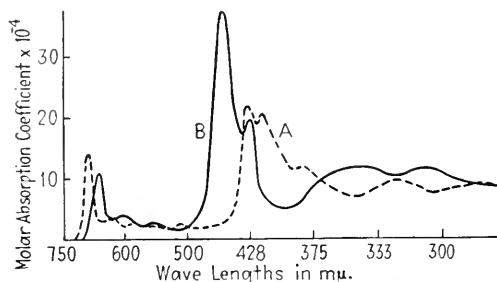

FIG. 3.—Absorption curves in benzene of A, chlorophyll *a*; B, chlorophyll *b*. (Winterstein and Stein, 145.)

activity of different wavelengths of light of the same incident intensity. In order to avoid the influence of the physical structure of the leaf on the determination of the absorption spectra of leaf pigments many investigators have used extracts of the leaf pigments in organic solvents. In general these solutions show the same type of absorption curve as the leaves themselves, which are characterized by strong absorption in the red and violet and high transmission in the green. In acetone and alcohol extracts of leaves the absorption curves are shifted toward the violet as compared with the absorption curves of the living leaves, Fig. 1. The narrow absorption bands characteristic of pure chlorophyll solutions are not evident in the absorption curves of leaves.

On the basis of chromatographic adsorption experiments the principal chloroplast pigments are: chlorophyll *a*, chlorophyll *b*, α - and β -carotene, and the xanthophylls (144). The pigment content of leaves varies with the conditions under which the leaves are obtained. On the basis of percentage dry weight the amount of chlorophyll is greater for shade than for sun plants, whereas the amount of yellow pigment is approximately the same (142, page 112). The total chlorophyll varies from about 0.5 to 1.2 per cent and the total yellow pigments from about 0.1 to 0.2 per cent, in a number of leaves. The ratio of

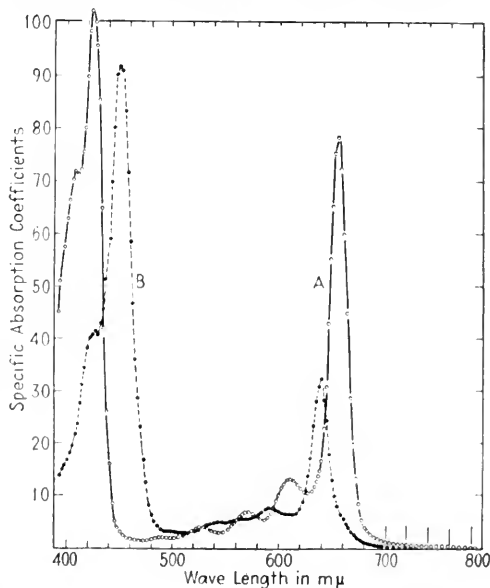

FIG. 4.—Absorption curves in ether of A, chlorophyll *a*; B, chlorophyll *b*. (Zscheile, 153.)

chlorophyll *a* to chlorophyll *b* averages 2.93 ± 0.6 ; the ratio of xanthophyll to carotene, 1.83 ± 0.5 .

Other pigments occur in smaller and varying amounts, but as yet these have not been definitely identified. "Leaf xanthophyll" is composed of several pigments, but the principal component from a number of plants has been identified as chiefly lutein (59). The proportion of the carotenes varies in different leaves (110), but thus far β -carotene has been found in all leaves examined. In many leaves it is the main component of this group of pigments (48). While α -carotene also occurs in many leaves, it very rarely comprises more than a small fraction of the carotene mixture.

The absorption spectra of the two chlorophyll components have recently been determined by Winterstein and Stein (145) in benzene solution and by Zscheile (153) in ether solution, Figs. 3 and 4. There is obviously considerable difference in the ratio of the absorption coefficients of the two chlorophylls observed by the two investigators which probably cannot be ascribed entirely to the different solvents used.

The absorption spectra of lutein and zeaxanthin as determined by Kuhn and Smakula (60) are reproduced in Fig. 5.

The absorption spectra of α - and β -carotene are given in Fig. 6. In this connection it may be stated that the absorption spectra of β -carotene and zeaxanthin are very much alike, as are also those of α -carotene and lutein. It is interesting to note that of these pigments the

ones with unlike absorption spectra, β -carotene and lutein, have been found to be the principal carotenoid components.

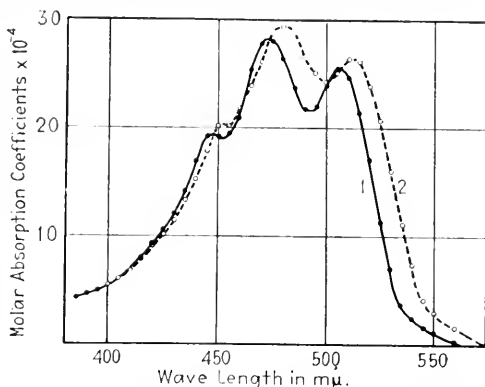

FIG. 5.—Absorption curves in carbon bisulphide of 1, lutein; 2, zeaxanthin. (Kuhn and Smakula, 60.)

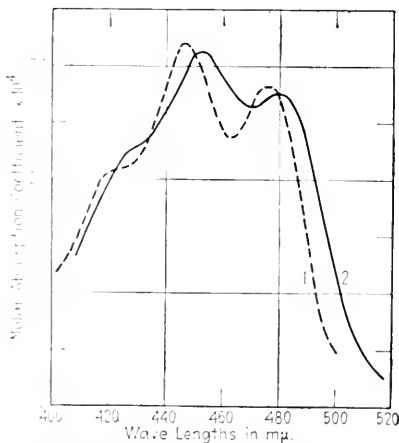

FIG. 6.—Absorption curves of 1, α -carotene; 2, β -carotene in 95 per cent ethanol. Molar absorption coefficient,

$$\epsilon = \frac{2.303}{1c} \log \frac{I_0}{I}$$

(Smith and Milner, 110.)

The absorption of some of the leaf pigments in the infra-red and ultra-violet regions of the spectrum has been reported (14, 112, 127, 128), but a discussion of these does not seem pertinent to this review, because photosynthesis does not take place in these spectral regions.

The absorption bands of a colloidal suspension of chlorophyll are not so sharp and are shifted to the red as compared with the absorption bands of a true solution of chlorophyll (34, 143, 147). The absorption

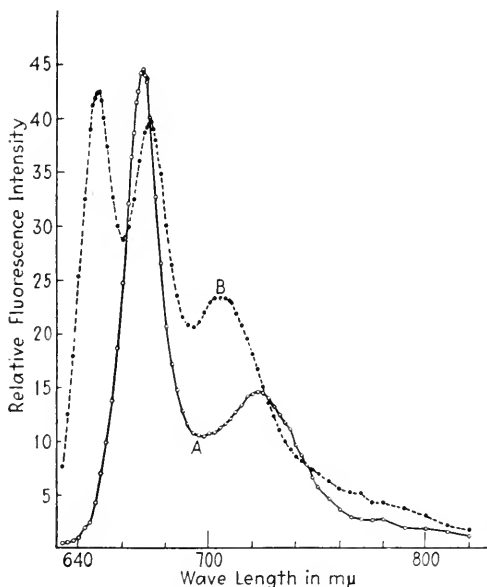

FIG. 7.—Fluorescence spectra in ether of A, chlorophyll *a*; B, chlorophyll *b*. (Zscheile, 154.)

bands of colloidal chlorophyll very nearly coincide with those of a living leaf. It has, therefore, been concluded that in the leaf, chlorophyll exists in a colloidal state. Against this supposition, however, is the fact that colloidal chlorophyll does not fluoresce, whereas one of the most striking properties of chlorophyll *in situ* is its characteristic fluorescence spectrum (50). It is, of course, possible that in the leaf chlorophyll may be adsorbed on certain colloidal cell constituents, for it has been found (84) that chlorophyll adsorbed on kaolin, alumina, or globulin, especially in the presence of fats and lecithin, exhibits its characteristic fluorescence. In the living cell the chlorophyll is apparently combined in this manner with some protoplasmic protein (66, 67, 79).

In true solution chlorophyll *a*, chlorophyll *b*, and carotene show fluorescence (40, 58, 154). The fluorescence spectra of the chlorophylls in ether solution are shown in Fig. 7 (154).

The products of photosynthesis, as far as they are known, are optically active. The recent discovery of Stoll (119*a*) that both chlorophylls exhibit optical activity is therefore of considerable interest. For freshly prepared solutions $[\alpha]_{720}^{25}$ chlorophyll *a* (+1H₂O) = -262°, chlorophyll *b* (+1H₂O) = -267°. It is important that Stoll has demonstrated that this optical activity of the chlorophylls arises from the portion of the molecule which yields phaeophorbides and cannot be ascribed to the phytol, the optical activity of which has recently been questioned (132). The optical activity of chlorophyll is maintained during photosynthesis though it disappears rapidly in solutions of chlorophyll in organic

solvents. Stoll stresses the fact that all the asymmetric carbon atoms of chlorophyll carry labile hydrogen atoms and that these are responsible for the ease of racemization and also for the fact that chlorophyll acts as a hydrogen donor in the photosynthetic reaction.

The principal carotenoid constituent of leaves, lutein, has a specific rotation of $[\alpha]_{6458} = +145^\circ$ in ethyl acetate; α -carotene, $[\alpha]_{6678}^{19} = +352^\circ$ in benzene; β -carotene is optically inactive.

The observation that photosynthesis in the brown and red algae is more nearly equal for light of different spectral regions of equal intensity than it is in the green plants (51, 21) is of particular interest for the correlation of photosynthesis with the absorption spectra of the plants themselves and of their pigments. The pigment complex of these plants is quite different from that of green plants. Besides chlorophyll, they contain chromoproteins, the absorption spectra of which are complementary to the absorption spectra of the chlorophylls. The component ratio of the chlorophyll differs in the brown and red algae from that found in green plants (6). The brown algae also possess a carotenoid, fucoxanthin ($C_{40}H_{56}O_6$), which thus far has not been isolated from green plants.

The absorption bands of these pigments are (28, 61):

Phycocerythrin	in water	$\lambda 5690-5650 \text{ \AA}$	$5410-5370 \text{ \AA}$	4980-4920 \AA
Blue phycocyanin	in water	$\lambda 6150-6100 \text{ \AA}$	5770-5730 \AA	
Blue-violet phycocyanin	in water	$\lambda 6180-6130 \text{ \AA}$	5530-5490 \AA	
Fucoxanthin	in chloroform	$\lambda 4920 \text{ \AA}$	4570 \AA	

The fluorescence bands have been reported (6) as:

Phycocerythrin.....	$\lambda 5790 \text{ \AA}$
Blue-green phycocyanin.....	$\lambda 6550 \text{ \AA}$

The pigment complex of the purple bacteria (bacteriopurpurin), is different from that of the green plants (10). By observing the motility of these organisms in a microspectrum they are seen to collect in sharp bands which corresponded to the absorption bands of the bacteria themselves. When culture flasks of these organisms are placed in the light surrounded by a bath containing a filter of green organisms, the purple bacteria thrive whereas green organisms fail to develop under the same circumstances. This has been attributed to the fact that the purple bacteria possess absorption bands which are complementary to those of the green organisms, and that these organisms probably assimilate in these spectral regions. The absorption bands have been observed at the following wave-lengths: 9100 to 8900; 8700 to 8400; 8100 to 7850; 7600 to 7000; 6100 to 5750; 5400 to 5150; 5000 to 4850 (?); 4700 to 4550 \AA .

Definite proof of the photosynthetic activity of the purple sulfur bacteria (129) and the red sulfur bacteria (31a) has now been found.

Although the sulfur-free purple bacteria have not been shown to be autotrophic, they can grow in the dark on organic media only in the presence of oxygen (129).

The pigment complex of these bacteria has been found to contain two principal pigments, one green corresponding to, but not identical with, the chlorophyll of higher plants, bacteriochlorophyll (102), and a purple pigment, bacterioerythrin (129a).

The bacteriochlorophyll is similar to chlorophyll in composition. It appears to be made up of two components corresponding to chlorophylls *a* and *b*. The ratio of the two pigments is, however, reversed. In ether the following bands have been reported:

E.A. 6810 Å; 5920–5640 Å; 4240 Å. E.A.

The purple component is of carotenoid nature. Its formula is $C_{48}H_{66}O_3$ (129a). The absorption maxima are:

In carbon bisulfide: λ 5690, 5300, and 4990 Å.

In ethanol: λ 5280, 4950 Å.

It is worthy of note that in this photosynthetic organism also, the pigment complex is composed of both a chlorophyll and carotenoid compound, absorption bands of which are nearly complementary.

EFFECT OF LIGHT INTENSITY IN PHOTOSYNTHESIS

In recent years the effect of light intensity on the photosynthetic process has been extensively investigated. The experiments show that the "limiting factor" or Blackman hypothesis can never be fully realized and can be approached in only a few cases. The "relativity law" (72), on the other hand, cannot be examined critically because of the difficulties in discerning and in handling quantitatively the large number of variables simultaneously operative in photosynthesis.

Hoover, Johnston, and Brackett (44) conclude that there is "linear variation of carbon assimilation as a function of light intensity . . . over a limited range." The results indicate that the Blackman principle is closely approached, notwithstanding the lack of ideal experimental conditions for "not all the chloroplasts can be maintained in the same light intensity, nor can all the surfaces of the leaves be brought in contact with exactly the same concentration of carbon dioxide. . . . On this account there is a transition region about the point of inflection." Van den Honert (125), using the filamentous alga *Horridium flaccidum*, found that when light is the limiting factor the properties of the assimilation process agree fairly well with Blackman's formulation. The deviations found, however, amounted to 25 or 30 per cent at the transition points.

The opposite conclusion is reached by van der Paauw (126), who also worked with this alga. He obtained a logarithmic relationship with algae cultivated in daylight and states, "An approximation of the Blackman scheme is apparently out of the question." When these organisms are cultivated in weak light an apparent inhibition of the photosynthetic action is produced when the assimilation is measured at high light intensities. The results of Montfort (80) on the alga *Fucus vesiculosus* agree very well with the limiting factor hypothesis. On the other hand, the results of experiments made on the shade fern *Trichomanes radicans* at low light intensities agree better with the relativity law. At higher intensities there is a complete inhibition of photosynthesis. Boysen-Jensen (7) investigated these relations in *Sinapis alba* and Müller (81) in *Chamaenerium latifolium* and in *Salix glauca*. While these investigators drew no conclusions as to the validity of either hypothesis, the curves published conform more nearly to the Blackman principle.

Maskell (74) attempted to find a quantitative expression which would represent the march of photosynthesis under different conditions of light intensity, carbon dioxide concentration, and also with consideration of the diffusion resistance of carbon dioxide. Even though the equation derived met with some success in depicting the rates of assimilation, Maskell concludes: "It is impossible, however, to suggest any general picture of more than limited validity. Regarded and used as a clue to the interpretation of the phenomena, the general principle of limiting factors suggested by Blackman in 1905 cannot as yet be replaced."

INHIBITION BY HIGH LIGHT INTENSITIES

The inhibitory effect of high light intensities has been investigated more fully by Montfort (80), who found that the rate of photosynthesis of the shade fern *Trichomanes radicans* increased up to one-eighth full daylight, and then decreased until at one-half full daylight the assimilation ceased. Similar results (80a) were found for the red alga *Rhododymenia* and for the green alga *Cladophora*. When returned to favorable conditions, the plants regained their original photosynthetic rate.

An adequate explanation of this inhibitory effect has not been found. It is not known whether it is an inhibition of the photosynthetic process itself, an accelerating effect on some other process such as respiration, or temporary injury of the protoplasm.

Nutritional Factors.—The rate of photosynthesis at different light intensities is considerably influenced by the nutrition of the plant. Van der Paauw (126) has shown that increase in the sugar concentration of the nutrient solution for *Hormidium* increases the photosynthesis. The effect is greater at low intensities of light than at high. Müller (81a) found that addition of small amounts of potassium nitrate in the

nutrition medium of *Sinapis alba* increases the photosynthetic rates at all light intensities.

Gregory and Richards (35) observed that barley plants deficient in nitrogen and phosphorus showed almost normal photosynthesis at low light intensities, but subnormal photosynthesis at high intensities of light. Deficiency in the potassium ion caused subnormal photosynthesis at all light intensities. Gassner and Goeze (33), on the other hand, found the highest assimilation value with potassium deficiency.

Chemical Inhibitors.—Warburg (133a) has investigated the inhibitory influence of cyanides on photosynthesis at different light intensities. He has found that the inhibition by cyanides is relatively more pronounced at the higher light intensities. Van der Paauw (126) has shown that 0.0001 molar HCN stimulates photosynthesis in *Horridium* at all light intensities, while 0.001 molar concentration produces a retardation at all intensities. The retardation is greater at high intensities; this is so great that the photosynthetic rate passes through a maximum. Other experiments with HCN show that the photosynthesis actually goes below the compensation point. Phenylurethane at 2.4×10^{-4} moles per liter produces a lowering of the photosynthetic rate at all the light intensities investigated by van der Paauw.

Temperature.—The results on the simultaneous change of temperature and light intensity are so complicated that it is possible to give only the barest outlines of the effects produced.

Investigating the influence of temperature on the photosynthetic rate of *Chlorella*, at constant light intensity, Emerson (23) found a sigmoid relationship. In an attempt to calculate the heat of activation of the photosynthetic process by the Arrhenius equation he found that it varied with the temperature, thus indicating a complex reaction mechanism. Müller (81) observed that the rate of photosynthesis at low light intensities was greater when the temperature was low than when it was high. At higher light intensities, however, a greater photosynthetic rate was observed at higher temperatures. Neydel (83) has demonstrated graphically the difference in plants relative to their temperature-photosynthesis relations at different light intensities. For *Trichomanes* the rate of change of photosynthesis with temperature is constant at three different light intensities. The sun alga *Cladophora* passing through the same temperature range shows a maximum. *Fontinalis* and *Spirogyra* have also been found to have temperature optima (Matsubara, 75). Photosynthesis at lower temperatures (5°C.) is much greater for *Fontinalis* than for *Spirogyra*.

Lundegårdh (73) found that photosynthesis in the potato leaf passes through several temperature optima at constant light intensity. This observation has thrown a new aspect on the problem. This type of behavior has been confirmed by Yoshii (152) for the bean leaf, and by

Ehrke (20) for different algae. These temperature optima are not fixed but vary with changes in light intensity and carbon dioxide concentration. They are shifted to lower temperatures with lower light intensities. The meaning of these results is still obscure.

Light and Internal Factors: Water.—Although water enters chemically into the photosynthetic reaction, very little has been done of a quantitative nature on the role of water as an internal factor. Dastur (16, 17) has presented some evidence that there is some correlation between water content and the rate of photosynthesis, though the relationship of this internal factor to photosynthesis is still quite involved.

Chlorophyll.—On the basis of their extensive quantitative investigations Willstätter and Stoll (143) concluded that the chlorophyll content does not change during the course of photosynthesis and that there is very little change in the ratio of chlorophyll *a* to *b*. Under experimental conditions in which neither light intensity, temperature, nor carbon dioxide concentration is determining the rate of photosynthesis, the influence of the internal factors becomes most pronounced. In various leaves of different chlorophyll content no direct proportionality between chlorophyll content and photosynthetic rate is observable. That is, there are other internal factors, besides chlorophyll, which determine the rate. Under conditions of ample carbon dioxide supply, a change in light intensity has little effect on leaves rich in chlorophyll, while such a change produces decided effects in the photosynthetic rate in leaves which are low in chlorophyll. On the other hand, leaves high in chlorophyll are affected in their photosynthetic rates by changes in temperature, while leaves low in chlorophyll show a relatively slight change in their rates due to temperature. These facts have been interpreted thus: In the leaves rich in chlorophyll this factor is in excess of an enzymatic factor which is strongly influenced by temperature. A change in temperature, therefore, will exert an influence on the photosynthetic rate through the action on the enzymatic factor which in these leaves is in relatively low concentration. Conversely, in leaves poor in chlorophyll, temperature has little effect, because here the enzymatic factor is in excess of the chlorophyll. Under these conditions, light intensity controls the rate. Only under conditions in which the chlorophyll is completely utilized, *i.e.*, with relatively high light intensity, can the enzymatic factor exert its full influence. This interpretation is largely based upon the Blackman theory that the rate of photosynthesis is determined by the pace of the slowest factor. In all probability, however, conditions are not quite so simple as would appear from such an interpretation.

Emerson (22) has found that increase in chlorophyll content in *Chlorella* augments photosynthesis proportionately in any one series of cultures. When, however, different series of cultures are compared the

proportionality is not found. Emerson also found (23) "that at low light intensities the same amount of photosynthesis may be carried on by much or little chlorophyll. The chlorophyll is more efficient when dilute." Light saturation, however, is apparent at lower intensities for cells deficient in chlorophyll than for those rich in the pigment.

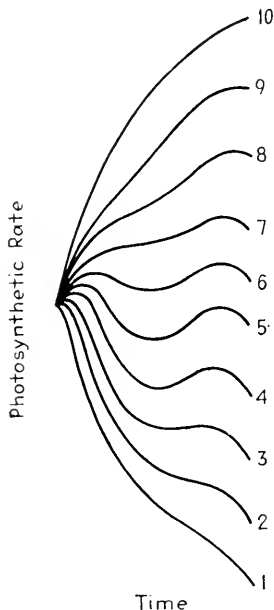

FIG. 8.—Schematic representation of possible curves of photosynthetic rates under constant external conditions, showing the effect of the light intensity under which plants were cultivated. The shape of the curve is dependent upon the ratio of the light intensity used in the cultivation of the plants to that in which the photosynthetic rates are determined. With low intensity of cultivation and high intensity of experiment, low ratio, curve 1 is obtained. With high ratio, curve 10 results. (Harder, 38a.)

at 4000 lux an initial increase followed by gradual decrease; and at 2340 lux the photosynthesis proceeded at a fairly uniform rate.

Following his earlier work, Harder (38a) found contradictory results with *Fontinalis* sp. Instead of the initial increase and subsequent decrease, he observed an initial decrease and subsequent increase in the rate of photosynthesis. An extensive investigation of this discrepancy

Light Intensity and Morphological Factors.—

It must be realized that photosynthesis is affected by morphological changes, permeability of the protoplast, tropic orientations of the chloroplasts, and by changes in stomatal aperture. All of these are influenced by light. This means that the experimental approach to the problem of photosynthesis, especially in land plants, is faced with many complexities, a full discussion of which is beyond the scope of this review (74, 131).

Time Effect in Photosynthesis.—Harder (38) has shown that when *Fontinalis antipyretica* and *Cladophora* are brought into the light, the photosynthetic rate gradually increases for several hours, "induction period." When the rate has reached its peak it then decreases, "fatigue." In contrast to the induction period of several hours found by Harder, Emerson (23) reports that 15 min. is sufficient to attain maximum photosynthesis in *Chlorella*. The results of van der Paauw indicate that in *Hormidium* an induction period of from $\frac{1}{2}$ to little more than 1 min. is necessary, the time depending on the temperature.

Later work by Arnold (1) showed that the behavior of the plant was largely dependent on the light intensity employed. He observed that at 90,000 lux (daylight) the photosynthetic rate of *Elodea canadensis* decreased rapidly; at 18,000 lux a gradual decrease; at 6000 lux an initial increase then a decrease;

led to the conclusion that these effects were the result of the previous light treatment of the experimental plants. Plants cultivated in fairly strong light showed an induction period when placed in strong light; plants cultivated in weak light showed the decrease in photosynthesis when experimented on in strong light. The shape of the curve depended on the relative light intensities used in the cultivation and in the subsequent experiments. These relations are schematically represented in Fig. 8, prepared by Harder. Also Harder's results show that "shade" and "sun-plants" have real significance, that one form of plant can be transformed into the other, and that the change from weak-light plants to strong-light plants is faster than the reverse change.

Sudden changes in the intensity of illumination cause immediate changes in the rate of photosynthesis. Thus Li (63) has shown that a decrease in light intensity results in an immediate drop in rate which then again rapidly rises. Similarly an increase in light intensity results in an immediate acceleration followed by a rapid decrease in rate. Changes from one spectral region to another of equal available energy produce no appreciable variation in photosynthetic rate. Kostytschew (56) and his associates have reported that under "natural conditions" the course of photosynthesis during the day is extremely variable. In some plants the rate increases to midmorning, decreases to midday when oftentimes carbon dioxide is evolved, then increases to midafternoon and falls to night.

Compensation Points.—The compensation point is the light intensity at which carbon dioxide is neither absorbed nor evolved. In general, this decreases with decreasing temperature (Müller, 81), but is very different in different species, depending in a large measure upon the rate of respiration of the plant. Ehrke (20) has shown that different species of algae kept under similar conditions possess compensation points at 16° which vary from 457 meter-candles for *Enteromorpha compressa* to 270.3 for *Delesseria sanguinea*. The highest compensation point yet reported is 4200 Lux for the lichen *Peltigera canina* (81b). Gregory and Richards (35) found that when the respiration of barley plants, deficient in phosphate nutrition, is plotted against the compensation point a straight line is obtained.

The intensity of the light used to adapt the plant is a very important factor in determining the compensation point of the individual. Harder (39) showed that when one sample of *Fontinalis* sp. is separated into two portions and one is kept in the sun and the other in the shade, the shade plant had a compensation point of 37 meter-candles, and the sun plant 170.

The irregularities in the rate of photosynthesis under natural conditions which have been reported by Kostytschew (56) and the remarkable fluctuations in rates of carbon dioxide evolution observed by Jaccard (45)

would indicate that the rate of gaseous exchange, and consequently also the compensation point, may be influenced by other means than the direct effect of external factors.

THE LIMITS OF LIGHT INTENSITY UTILIZABLE IN PHOTOSYNTHESIS

Ehrke (20) quotes Lubimenko as stating that in a depth of 50 meters in the Black Sea there is still perceptible photosynthesis with the green as well as with the red algae. Gail (32) found that in Puget Sound the lower limit at which photosynthesis takes place in both the red and brown algae is 35 meters. The light penetrating the water at these depths is probably of the order of 1×10^{-7} and 1×10^{-5} that of sunlight and composed largely of violet light (Oberdorfer, 87). For comparison, this is probably of the same order of intensity as moonlight. Kostytschew (57) found that in arctic regions some plants are photosynthetically active throughout the whole 24 hours in July. Müller (81) also states that from the position of the compensation point and the light intensity at 69 deg. North it is possible to have photosynthesis during the whole 24-hour day. Little work is available on the upper limit of light intensity for photosynthesis. Pantanelli (89) reported that the evolution of gas still continued when *Elodea canadensis* was illuminated with light 64 times as strong as sunlight.

EFFECT OF WAVE-LENGTH ON PHOTOSYNTHETIC RATES

Infra-red.—Very meagre information is available for the influence of infra-red radiation on the photosynthetic process. What data there are indicate that this region of the spectrum is not capable of inducing photosynthesis (Warburg and Negelein, 137). Schmucker (101) removed all light of wave-length shorter than 7700 Å from a light source rich in infra-red and found no photosynthesis. Burns (12) concludes that infra-red to $\lambda 11,000$ Å is detrimental to photosynthesis in white pine. Klugh (51) observed no photosynthesis in *Enteromorpha Linza* with infra-red radiation.

TABLE 3.—PHOTOSYNTHETIC EFFICIENCIES IN DIFFERENT SPECTRAL REGIONS AS DETERMINED BY BRIGGS

	Cc. O ₂ per 500 cal. of incident energy		
	Yellow-red $\lambda 5700-6400$ Å	Green $\lambda 5100-5600$ Å	Blue $\lambda 4300-5100$ Å
<i>Phaseolus vulgaris</i>	15.4	10.3	7.5
Yellow elm.....	8.8	6.5	5.3
Green elm.....	20.0	12.3
<i>Sambucus nigra</i>	8.7	9.3	8.7
<i>Sambucus nigra</i>	19.0	15.0

Visible.—Recent determinations have confirmed the older results that the red and yellow-red regions of the spectrum are the most effective in photosynthesis. Results obtained by Briggs (8) are given in Table 3. He has given his results in cubic centimeters of oxygen evolved for each 500 calories of light incident on the leaf, because, on the average, the heat of evolution of 1 cc. of oxygen from organic material is 5.0 cal. This convention was adopted in order to avoid all assumptions as to the mechanism of the process and the troublesome estimations of the energy absorbed by the leaves. For all practical purposes, however, these values are comparable to those reported in per cent by other investigators. The values of Briggs were apparently not obtained with the same incident light intensity and may, therefore, be subject to some error due to the fact that photosynthetic activity is not always directly proportional to the intensity.

To what extent and in what manner the presence of pigments other than chlorophyll influences photosynthesis has not yet been definitely determined. Schmucker (101) found that *Cryptocoryne ciliata*, which was red on the under surface, gave only half the photosynthesis when the red side was turned to the light as compared to the activity with normal exposure. According to Ehrke (21) the green alga, *Enteromorpha compressa*, exhibited a higher rate of photosynthesis in red than in green or blue light; the red alga, *Delesseria sanguinea*, showed very little difference in the three spectral regions. Harder (37) has criticized these results on the basis of lack of uniformity of treatment previous to the photosynthesis determinations and because of the fact that photosynthesis never exceeded respiration, though he considers that in the main the results present a true picture. Similar results were obtained by Klugh (51), which are summarized in Table 4.

TABLE 4.—RELATIVE RATES OF PHOTOSYNTHESIS OF GREEN, BROWN, AND RED ALGAE IN DIFFERENT SPECTRAL REGIONS ACCORDING TO KLUGH

	Wave-lengths		
	$\lambda 7200-6300 \text{ \AA}$	$\lambda 5600-5050 \text{ \AA}$	$\lambda 4800-4000 \text{ \AA}$
<i>Enteromorpha Linza</i> (green).....	1.80	0.16	1.16
<i>Porphyra umbilicalis</i> (brown).....	2.46	1.65	1.65
<i>Delesseria sinuosa</i> (red).....	1.35	1.25	1.05

Ultra-violet.—Little work has been done on the effect of ultra-violet light on photosynthesis. Arnold (2) found that irradiation with light of $\lambda 2537 \text{ \AA}$ reduced the rate of photosynthesis of *Chlorella pyrenoidosa* in proportion to the amount of radiation. He concluded that the effect of the ultra-violet light was directly on the photosynthetic apparatus of the plant.

WAVE-LENGTH LIMITS OF PHOTOSYNTHESIS

The wave-length limits for photosynthesis have not been definitely established. In fact, it is very probable that they will differ for different species of plants. Burns (12a) found the limits in *Pinus Strobus* and *Picea excelsa* were from about 7400 Å to 4500 Å. The long-wave limit agrees fairly well with that found by other investigators. The short-wave limit seems to be too far in the visible. It is probable that the light source used by Burns was too weak in violet rays to give adequate illumination. Ursprung (123) found that the limits for starch formation under ordinary illumination lie between λ 7600 and 3300 Å. In a 40-hr. exposure, however, through an ebonite plate which removed all visible radiation a small amount of starch was formed. Meier (78) irradiated plate cultures of the alga *Chlorella vulgaris* with ultra-violet lines from the mercury arc. All wave-lengths below 3022 Å were injurious.

THE MECHANISM OF THE PHOTOSYNTHETIC REACTION

It was the great contribution of F. F. Blackman (5) to describe the relation of the photosynthetic reaction to the various environmental factors which affect it. Starting from this point Willstätter and Stoll (143) defined the quantitative relationships between the rates of photosynthesis and certain internal factors. They were concerned primarily with the function of chlorophyll. But through their quantitative studies they also brought to light the fact that another internal factor, associated with the colorless portion of the cell protoplasm was operative, a concept which in a qualitative way had been expressed by a number of earlier investigators. Warburg (133) then demonstrated that, with high light intensity and high CO₂ concentrations, the temperature coefficient of photosynthesis varies decidedly with the temperature. Under these conditions the temperature coefficient decreases with increasing temperatures: between 5° and 32° the temperature coefficient decreases from 4.3 to 1.6. Thus, with high light intensity a rise of 10°, from 15° to 25°, causes approximately a doubling in the rate of photosynthesis. Here the rate of the total reaction is evidently determined by a chemical dark reaction. At low light intensity the rate of photosynthesis is independent of the temperature between 15° and 25°. Under these conditions a photochemical reaction is determining the rate of the total reaction.

These facts indicate that at least two fundamentally different reactions are involved in the photosynthetic process. The dark reaction (Warburg, 138, 150) has been designated as the "Blackman reaction." This reaction is sensitive to changes of temperature and is also decidedly affected by low concentrations of hydrocyanic acid. Its characteristics become evident when rates of photosynthesis are measured at high light intensities. Emerson (23) has made careful measurements of these

rates at small temperature intervals. His measurements also give some indication that chlorophyll itself is involved in the Blackman reaction. The photochemical reaction, on the other hand, is affected little by changes in temperature or by hydrocyanic acid.

The exact nature of these reactions has not yet been determined. Willstätter and Stoll (143) suggested that chlorophyll adds carbon dioxide, that this addition compound through a photochemical reaction undergoes a rearrangement or isomerization resulting in a peroxide-like compound. The latter breaks down with the liberation of oxygen, catalyzed by an enzyme, and constitutes the Blackman reaction. Warburg and Uyesugi (138) have found some confirmation of this conception

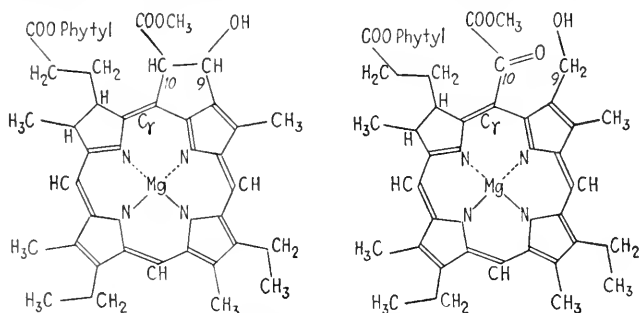

FIG. 9.—Structural formulas of chlorophyll *a* (left) and chlorophyll *b* (right). (Stoll and Wiedemann, 119.)

in an investigation of the rates of decomposition of hydrogen peroxide by *Chlorella*, although the agreement of this with the Blackman reaction is not complete and could not be in view of the fact that Willstätter and Stoll's peroxide is not hydrogen peroxide.

Recently Stoll (114, 115, 116, 117, 118, 119, 119*a*.) on the basis of his extensive investigations of the structure of chlorophyll has put forward an elaboration of the hypothesis of Willstätter and Stoll just referred to. According to this view the photosynthetic process is composed of the following steps:

a. The union of carbon dioxide or a carbon dioxide compound with chlorophyll, resulting in the entry of the carbon dioxide into the molecule of the light acceptor.

b. The first photochemical reaction, resulting in the rearrangement of the chlorophyll-carbon dioxide combination with the possible formation of a peroxide.

c. The reduction of the carbon dioxide, or its rearrangement product. This is accomplished through hydrogenation, in which the chlorophyll-carbon dioxide complex is the hydrogen acceptor and a hydrogenated form of chlorophyll is the hydrogen donor. This hydrogenated form of chlorophyll is supposed to arise from a hydrogenation of the chlorophyll at carbon atom 9 in the chlorophyll molecule. Thus, the reduction of

the carbon dioxide (or its rearrangement product) is not accomplished directly through the splitting off of oxygen, but rather through the formation of water (Fig. 9).

d. The second photochemical reaction is the hydrogenation of chlorophyll and formation of a hydrogen donor. It is known that chlorophyll can hold a small amount of water with great avidity. It is assumed that this combined water is decomposed through the action of light:

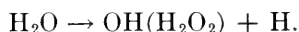

The chlorophylls are easily partially hydrogenated without affecting their absorption spectrum. It is assumed that herein the point of attack is at carbon atoms 9 and 10 in the chlorophyll molecule.

e. The hydrogen peroxide formed in the reaction shown above is broken down in the cell by catalase, with the liberation of oxygen.

Indication of labile addition compounds of chlorophyll with carbon dioxide, carbon monoxide, and oxygen has been obtained by Padoa and Vita (88) who observed shifts in the spectral absorption bands of solutions of chlorophyll when treated with these gases.

The fact that chlorophyll contains an easily dehydrogenated group has been utilized by Conant, Dietz, and Kamerling (13) as the basis of a theory of the mechanism of the photosynthesis. They suggest that the first step is the reduction of carbon dioxide by chlorophyll itself, the latter being converted to dehydrochlorophyll. This step would involve the action of an enzyme and would constitute the Blackman reaction. The regeneration of chlorophyll from dehydrochlorophyll would require energy and this is assumed to occur in a photochemical reaction. According to this view, the reduction of carbon dioxide proper would take place in the dark and only the regeneration of chlorophyll from dehydrochlorophyll would involve a photochemical reaction. As Stoll (114) points out, however, with this formulation, the dehydrochlorophyll would be expected to be the more stable form and this has never been found in leaves. Another modification of the Willstätter and Stoll theory has been proposed by Shibata and Yakushi (105, 151) in which water is added to the carbon dioxide-chlorophyll complex on the magnesium.

An interesting case of a modified form of photosynthesis is presented by the purple and green sulfur bacteria which have recently been investigated by van Niel (129, 130). These organisms require hydrogen sulfide and light for their development. The purple forms can also utilize elementary sulfur, sulfites, and thiosulfates, and oxidation products of these compounds, and reduction products of carbon dioxide result. Oxygen is not liberated by either the green or the purple forms. The net result may be expressed:



and in the case of the purple sulfur bacteria



The question is in what manner the oxidation of the H_2S is involved in the reduction of the CO_2 . Kluver and Donker (52) have suggested that in these organisms the H_2S is a hydrogen donor and the CO_2 the hydrogen acceptor. The concept has been elaborated by van Niel to the effect that in hydrogen sulfide the hydrogen is loosely bound and is already present in an active form while the green pigments may be regarded as the agents which cause the activation of the hydrogen acceptor, the carbon dioxide. According to this view, in ordinary autotrophic plants water must serve as the hydrogen donor and in this case oxygen is liberated. Any substance can act as a hydrogen donor to the carbon dioxide provided its hydrogen can be photochemically activated in the organism, and the reaction may be written:



Van Niel suggested that certain organic substances could serve as hydrogen donors for the reduction of carbon dioxide. Muller (82) cultured purple bacteria in the presence of organic substances and found that the bacteria developed only in the light. The difference in the amount of carbon dioxide taken up per unit of substrate consumed varied with the oxidation value of the substrate. Gaffron (31) has followed the photosynthesis of the nonsulfur bacteria which absorb carbon dioxide only in the light when grown on sodium salts of fatty acids. The ratio of the carbon dioxide absorbed to the organic acid used varied with different acids. For each increase in CH_2 in the carbon chain of the fatty acid there was an increase of 0.5 mole of carbon dioxide absorbed.

The results of experiments on photosynthesis in intermittent light have been used to elucidate the relation of the photochemical and Blackman reactions. Warburg (133) made comparisons between the effects of continuous and intermittent illumination. With high intensity of illumination, equal amounts of radiant energy reduced more carbon dioxide when this was intermittent than when it was continuous. The excess of photosynthesis in intermittent light depended upon the frequency of the flashes; when these were 8000 per minute this was almost 100 per cent, while with 4 per minute it was about 10 per cent. Warburg suggested that these results might be explained either on the assumption that the reduction of carbon dioxide proceeds during the dark periods with uninterrupted rate, or that the reduction is interrupted in the dark periods and proceeds at double the rate in the light periods. The latter of these he considered as the more probable.

In Warburg's experiments the light and dark periods were equal. Emerson and Arnold (24, 25), with an ingenious apparatus, by making the periods of illumination much shorter than the dark periods, were able to attain increased photosynthesis of 300 to 400 per cent over the continuous light with only 50 flashes per second. They have shown that the light reaction is not affected by temperature and is capable of proceeding at great speed, in about 0.00001 sec. On the other hand, the dark reaction is dependent on temperature and requires less than 0.04 sec. for completion at 25° and about 0.4 sec. at 1.1°.

It is as yet not known how the dark and light reactions work together in the photosynthetic process nor which of the two reactions may be considered to precede the other. Obviously this phase of the problem is greatly complicated by the fact that, as far as we know, photosynthesis is dependent upon living protoplasm.

One of the most striking properties of chlorophyll is its red fluorescence. When a molecule absorbs radiant energy it passes into an activated state. In this condition it may react or it may return to its normal state by loss of this energy through collision, reradiation of the same wave-length of light as absorbed (resonance) or reradiation of the energy as light of longer wave-length than that absorbed (fluorescence). It is well known that certain foreign substances have the ability to quench the fluorescence of compounds and that this process is accompanied by an activation of the foreign molecule (120). In this manner fluorescent compounds may act as transporters of radiant energy.

Oxygen strongly quenches the fluorescence of chlorophyll, whereas other gases such as nitrogen, hydrogen, and carbon dioxide do not have this effect (50). In view of the fact that oxygen has this property and has been shown to be excited by light in the same spectral region as the fluorescence of chlorophyll, and to remain in this activated state for as long as 7 sec. (76), it has been proposed that oxygen may play the role of a "collector and transporter" (50) of energy in the photosynthetic process. That chlorophyll and other fluorescent dyes sensitize photochemical oxidations has been amply demonstrated (29, 84).

Kautsky, Hirsch, and Davidshöfer (50) have reported the interesting fact that in living leaves this fluorescence is decidedly quenched during active photosynthesis. Inhibition of photosynthesis through hydrocyanic acid increases the fluorescence. These investigators conclude that the quenching of the fluorescence of chlorophyll during photosynthesis is caused by oxygen, that the radiant energy absorbed by chlorophyll is transferred to the oxygen, that, in fact, oxygen is the only molecule in the photosynthetic system to which the absorbed radiant energy is transferred. It is, of course, not yet clear what role is to be ascribed to the activated oxygen in the reduction of carbon dioxide. Willstätter (140) has questioned the conclusion of Kautsky that oxygen is the only

molecule to which the absorbed light energy is transferred and has suggested that chlorophyll itself may utilize this energy through a reaction with oxygen. A similar attitude has been taken by Gaffron (29) on the basis of his interesting investigations on the activation of oxygen by illuminated pigments.

THE ENERGY RELATIONS OF PHOTOSYNTHESIS

There are two ways in which the energy efficiency of photosynthesis may be expressed: one is the *apparent efficiency* in which the amount of energy stored by the leaf is stated as the fraction of the energy incident on the leaf; the other is the *real efficiency*, in which the amount of energy stored by the leaf is given as a fraction of the energy absorbed by the leaf. While still a third type of efficiency might be determined, in which the chemical energy stored is related to the light energy absorbed by the photosynthetic pigments, no method has as yet been found by which this estimation can be accomplished. It is only the radiant energy which is absorbed by the leaf that can be used in photosynthesis. Of this, however, only a small portion is used in the photosynthetic reaction, the rest being dissipated by transpiration and reradiation.

THE APPARENT EFFICIENCY OF THE PHOTOSYNTHETIC PROCESS

The apparent efficiency of the photosynthetic process has been determined in two different ways. In the first method the heat of combustion of two analogous portions of a leaf are determined before and after insolation. The increase in heat of combustion of the insolated portion is then compared with the total energy incident on the illuminated leaf during the period of exposure.

By the use of this method, Puriewitsch (92) has made an estimate of the energy storing efficiency of several kinds of leaves. The values found range from 0.6 to 7.7 per cent. Even though the values show great variation, they indicate that the efficiency of the leaf is very low in the conversion of the energy incident on it into stored chemical energy. This method has all the disadvantages of a half-leaf method. It lacks in accuracy, but further development and improvement might make it extremely useful in certain aspects of the photosynthetic problem.

In the second method, the energy stored by the plant is calculated from the idealized photosynthetic reaction on the basis of the amounts of carbon dioxide absorbed or of oxygen liberated. The ratio of this calculated energy to the total energy incident on the leaf during the insolation period is designated as the efficiency of the process. The photosynthetic reaction may be represented by the following idealized equation:

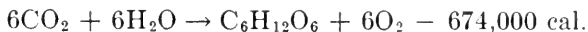

One of the most successful of the earlier attempts to use this method of determining efficiencies was made by Brown and Escombe (9). These investigators gave a very clear analysis of the disposition of the energy incident on the leaf. While their analysis lacks somewhat in completeness and accuracy, it still stands as one of the most comprehensive investigations in this field. The partition of energy which these workers found is given in the following table:

	Per Cent
Energy used in photosynthesis.....	0.66
Energy used in transpiration.....	48.39
Energy transmitted by leaf.....	31.40
Energy lost by thermal radiation.....	19.55

The researches both of Puriewitsch and of Brown and Escombe were carried out at high light intensities and the very low efficiencies which they obtained may be partially explained on this ground.

More recent attempts have been made by Briggs and by Burns to obtain estimates of the apparent energy efficiencies in different regions of the spectrum. Briggs (8) has measured the oxygen evolution of different leaves in yellow-red, green, and blue light. These results are shown in Table 3.

Burns (12) has attempted to obtain the quantum yields of the photosynthetic process at various wave-lengths for *Pinus Strobus*, *Picea excelsa*, and *Picea Engelmannii*.

THE REAL EFFICIENCY OF THE PHOTOSYNTHETIC REACTION

The theoretical aspects of the energetics of photosynthesis have been investigated by Warburg and his associates (135) and by Wurmser (148). Their researches have dealt not with the efficiency of the conversion of the light incident on the leaf under natural conditions, but with the efficiency of the conversion of the light absorbed by the photosynthetic organism under as nearly optimal conditions as possible—the *real efficiency* of the photosynthetic reaction.

According to the photochemical equivalence law the primary process in any photochemical reaction is the absorption of one quantum of energy, $Nh\nu$ (Table 5)³.

In order for a quantum of light to cause a reaction to take place, it must be large enough to supply the activation energy of the reaction. In the case of an endothermic reaction the quantum of energy must be

³ N is Avogadro's number, 6.061×10^{23} ; h is Planck's constant, 1.566×10^{-34} cal. sec.; and ν is the frequency of the light used, i.e., 2.9986×10^{10} cm. sec.⁻¹ divided by the wave-length in Ångström units $\times 10^{-8}$ cm. Therefore $Nh\nu = 2.846 \times 10^6/\lambda$, where λ is expressed in Ångström units. A useful nomograph for calculations of quantum energies has been published by Mecke and Childs (77).

TABLE 5.—QUANTA OF ENERGY FOR DIFFERENT WAVE-LENGTHS IN THE VISIBLE

REGION OF THE SPECTRUM	
Wave-length, Å	Quantum Energy, $Nh\nu$ (cal. sec.)
4000	71,200
5000	56,900
6000	47,400
7000	40,700
8000	35,600

great enough to supply the heat required by the reaction. Since photosynthesis is an endothermic reaction,

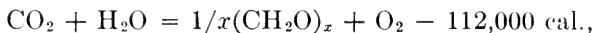

the energy quantum must be great enough to supply this energy. By a comparison of the energy of the reaction with the values given in Table 5, it is seen that in the visible region of the spectrum no quantum is equal to 112,000 cal., the amount necessary for the postulated photosynthetic reaction. This is one of the most difficult problems of a theoretical nature concerning the mechanism of this process.

The question is whether or not the process is dependent only on the thermal energy supplied by the light or whether it is a typical quantum process in which the amount of action is proportional to the number of quanta absorbed. If the reaction is dependent only on the thermal energy supplied by the light, the energy efficiency of the process should be dependent on the number of calories absorbed irrespective of the wave-lengths of light. If it is purely a quantum process the amount of reaction should depend on the number of quanta absorbed and the energy efficiency should increase at the longer wave-lengths.

Warburg and Negelein (134, 137), using the alga *Chlorella*, have attempted to determine which of these two processes fits the facts. They have determined the energy efficiencies with different wave-lengths of light. Their results are assembled in Table 6. In these experiments the arrangements were such that all of the incident light was absorbed by the organism and thus the uncertainties attending calculations of light absorbed by living organisms were eliminated. By extrapolation of the assimilation values obtained at known light intensities to zero light intensity, they made an effort to obviate variations due to light intensity.

On the basis of these experiments Warburg (136) concludes that the number of quanta necessary to decompose a molecule of carbon dioxide in the photosynthetic reaction is about 4. However, the number of quanta necessary in blue light is greater, about 5. This Warburg and Negelein attribute to the absorption of a part of the blue light by the yellow pigments. But Warburg considers that it is more correct to employ in the calculation only the energy absorbed by the chlorophyll. When this is done he finds that the number of quanta used in blue light is "less than 5 and more than 3, probably 4 quanta."

TABLE 6.—WARBURG AND NEGELEIN'S RESULTS ON THE ENERGY EFFICIENCY OF PHOTOSYNTHESIS IN CHLORELLA

Spectral region	$Nh\nu$	Energy efficiency, per cent	Quanta per mol. O ₂ evolved
Red λ 6100 to 6900 Å (6600 Å).....	43,000	59	4.4
Yellow λ 5780 Å.....	49,200	54	4.4
Green λ 5460 Å.....	51,900	(44)	
Blue λ 4360 Å.....	65,100	34	5.1

It appears, therefore, that the photosynthetic process is dependent on the quantum action of the photons rather than on the total heat energy which the light imparts to the assimilating plant.

Since Warburg and Negelein have shown that about four quanta are necessary for the production of 1 mole of oxygen it is obvious that the total energy requirements for the idealized photosynthetic equation are satisfied.

The relative energy efficiencies for different parts of the visible spectrum have recently been determined by Schmucker (101) with *Cryptocoryne ciliata* and *Cabomba caroliniana*. The relative values obtained for different wave-lengths agreed with those of Warburg and Negelein. Thus in two widely separated classes of plants the relative energy efficiencies are the same in different parts of the spectrum.

Briggs (8) has criticized the results of Warburg and Negelein because "Warburg and Negelein measured the assimilation under conditions where it was more than counterbalanced by respiration, and under such conditions the high energy efficiencies which they observed may have been due to the easy photolysis of some intermediate respiratory substance." This criticism seems unjustified when the primary objectives of these investigations are considered; this was an attempt to establish the theoretical basis on which the energy transfer depends. Under the conditions employed the disturbing influences of diffusion, fatigue, and photochemical inhibitions would be reduced to a minimum.

On the other hand, it was necessary for Warburg and Negelein to assume that the photosynthetic action alone is increased by the light without any simultaneous influence on the respiration. Briggs presents a further criticism that all the light absorbed by the algae was not absorbed by the photosynthetic pigments and that on this account the true energy efficiency of the assimilation process has not been determined in these experiments. While this criticism is justified (and also realized by the German investigators), it is difficult to see how any valid correction can be made at the present time. No means of circumventing this obstacle has as yet been found.

Experiments on the energy efficiency of photosynthesis have been carried out by Wurmser (148) using *Ulva lactuca*. The energy efficiency

in the red averaged 59.3 per cent and in the green 68.0 per cent, a ratio of 1.15 for green to red light. On the basis of quantum energies for the wave-lengths employed, 5400 Å (5900 to 4900 Å) and 6600 Å (7000 to 5900 Å), the ratio should have been 0.82. From this Wurmser concluded that the utilization in green light is greater than would be predicted and indicated that there was a more complete utilization of the absorbed energy in this region of the spectrum. This agreed qualitatively with his idea that there is an abrupt transition in the efficiency in going from the shorter to the longer wave-lengths, for there is enough energy in two quanta of blue light to carry out photosynthesis whereas in red light three quanta would be necessary. At about $\lambda 5000$ Å there should be an abrupt change in the number of quanta required accompanied by an abrupt change in the energy efficiency of the process.

Both Briggs (8) and Warburg (134) have criticized Wurmser's method of determining the energy efficiency. This criticism is based on the way in which he measured the light absorbed. This was determined by measuring the transmission through the algal film before and after it had been bleached by intense illumination. These criticisms have been refuted by Wurmser (149). It may be concluded from the data available that the photochemical action in the photosynthetic process is determined by the number of quanta rather than by the total energy in the light absorbed by the plant.

ENERGY TRANSFER

Since more than one quantum of energy is necessary for the photosynthetic reaction, it would be important to know in what manner the energy transfer takes place. In order to obtain enough energy to drive the reaction it would be necessary for the reacting system to absorb the number of quanta required either simultaneously or consecutively. Either of these mechanisms for the absorption of the requisite number of quanta would be, however, very unlikely unless the life of the activated process be relatively long. Even though this be the case it is improbable that such high yields would be obtained.

Although the life of most activated molecules is very short (10^{-5} sec.) that of an activated molecule of oxygen has been found by Meeke and Childs (76) to be of the order of 7 sec. Whether there is any relationship between the necessity of oxygen for photosynthesis, the extremely long life of the activated oxygen molecule and the possibility of energy exchange between the chlorophyll molecule and oxygen, as is evidenced by the quenching of the fluorescence of chlorophyll by oxygen (Kautsky, 49), will remain for future experiments to decide.

A more probable explanation for the accumulation of the energy necessary for photosynthesis is that the carbon dioxide molecule is reduced in a step-wise fashion, and that each step requires only the fractional amount of energy necessary for the total reduction. These

intermediate products could then by intermolecular oxidations and reductions build up the higher reduction products found in plants. In this connection an interesting correlation exists between the number of electrons that must be transferred to the carbon and the number of quanta necessary for the process as found by Warburg.

A further mechanism which would satisfy the energetic relations is that there may be plant products which supply the hydrogen necessary for the reduction of the carbon dioxide at a much lower energy level than water. These compounds may then return to their original state by the reduction of the water which also may be a low energy level reaction. By means of an integration of such low level processes the final result could then be obtained. The participation in these processes of intermediate products of the metabolism and respiration of the plant (Spoehr and McGee, 111) may account for the parallelism between respiration and photosynthesis (van der Paauw, 126).

PHOTOSYNTHESIS IN BACTERIA

Purple Sulfur Bacteria.—In the recent researches of van Niel, already referred to (129), on the metabolism of the purple sulfur bacteria, evidence has been advanced for a photosynthetic reaction in these organisms analogous to the photosynthetic reaction in green plants. In place of water, these bacteria apparently use hydrogen sulfide as a hydrogen donor for the reduction of the carbon dioxide. Instead of the evolution of oxygen they produce sulfur and in some cases sulfuric acid, though the cultures are all anaerobic.

It is extremely difficult to reason on the energetics of chemical reactions proceeding in such a complicated living system entirely on the basis of thermodynamic data. But in defense of his interpretation of the reduction of carbon dioxide in these organisms van Niel points out that "in order to obtain sufficient oxygen for the oxidation of 12 molecules of H_2S . . . the organisms would have to reduce 24 molecules of CO_2 . . . by a photochemical process. The quantity of oxygen thus obtained would be sufficient for a chemosynthetic process during which only 1 mol. of CO_2 could be reduced chemosynthetically, producing 0.3 mg. of organic matter." By experiment the amount of organic carbon synthesized was more than 15 times greater than can be accounted for on the basis of a chemosynthetic process. In this connection it is interesting that the purple sulfur bacteria have an absorption band in the infra-red and that they grow in this region of the spectrum. The quantum of energy here is less than in visible light and this may be associated with the lesser energy necessary for carbon dioxide reduction in this photosynthetic system.

The energetics of the photosynthesis of the nonsulfur bacteria studied by Gaffron (31) is also exceedingly complex. These organisms absorb

carbon dioxide only in the light and Gaffron has shown that various fatty acids may apparently serve as hydrogen donors. Whether this is a true photosynthesis, that is, an accumulation of energy at the expense of the light absorbed, is in the present state of our knowledge difficult to say. To what extent reactions here play a part analogous to some known in organic chemistry in which carbon dioxide is taken up by organic molecules, which in themselves are probably exothermic reactions, is as yet uncertain and open to speculation. The observations on these organisms clearly demonstrate that they can absorb carbon dioxide in the presence of light with a simultaneous catabolism of organic compounds. It lends support to the supposition that in the photosynthetic process two mechanisms, carbon dioxide absorption and oxygen liberation, may not be involved in the same reaction but in integrated reactions, either or both of which may be photochemical, a concept which has engaged the attention of plant physiologists for many years.

In conclusion it may be said that from the observations thus far assembled, the photosynthetic process is known to be an endothermic, energy storing process, in which the energy accumulated is a result of a photochemical reaction. The mechanism of the conversion of the light into the chemical energy is, however, still a mystery, because we are in ignorance of the nature of those conditions and factors essential for the reaction which are intimately associated with the protoplasmic activity of the living cell.

REFERENCES

1. ARNOLD, AUGUST. Der Verlauf der Assimilation von *Helodea canadensis* unter konstanten Aussenbedingungen. *Planta Arch. Wiss. Bot.* **13**: 529-573. 1931.
2. ARNOLD, WILLIAM. The effect of ultraviolet light on photosynthesis. *Jour. Gen. Physiol.* **17**: 135-143. 1933.
3. ARTARI, A. Zur Ernährungsphysiologie der grünen Algen. *Ber. Deut. Botan. Ges.* **19**: 7-9. 1901.
4. BAAS-BECKING, L. G. M., and P. A. ROSS. Notes on micro-spectra. I. *Jour. Gen. Physiol.* **9**: 111-114. 1925.
5. BLACKMAN, F. F. Optima and limiting factors. *Ann. Bot.* **19**: 281-295. 1905.
6. BORESCH, K. Algenfarbstoffe. Klein, G. *Handbuch der Pflanzenanalyse.* **3**(2): 1382-1410. Julius Springer; Wien, 1932.
7. BOYSEN-JENSEN, P. Über die Bestimmung der Assimilationsintensität. *Planta Arch. Wiss. Bot.* **21**: 368-380. 1933.
8. BRIGGS, G. E. Experimental researches on vegetable assimilation and respiration. XX. *Proc. Roy. Soc. London B* **105**: 1-35. 1929.
9. BROWN, H. I., and F. ESCOMBE. On the physiological processes of green leaves. III. *Proc. Roy. Soc. London B* **76**: 69-111. 1905.
10. BUDER, JOHANNES. Zur Biologie des Bacteriopurpurins und der Purpurbakterien. *Jahr. Wiss. Bot.* **58**: 525-628. 1919.
11. BURGERSTEIN, A. Über das Verhalten der Gymnospermenkeimlinge im Lichte und im Dunkeln. *Ber. Deut. Botan. Ges.* **18**: 168-184. 1900.

12. BURNS, G. RICHARD. Photosynthesis in various portions of the spectrum. *Plant Physiol.* **8**: 247-262. 1933. (*See also* (a) *Science* **78**: 130. 1933.)
13. CONANT, J. B., E. M. DIETZ, and S. E. KAMERLING. The Dehydrogenation of chlorophyll and the mechanism of photosynthesis. *Science* **73**: 268. 1931.
14. COBLENTZ, W. W., and R. STAIR. The infra-red absorption spectrum of chlorophyll and xanthophyll. *Phys. Rev.* (2) **33**: 1092. 1929.
15. DANGEARD, A. P. Observations sur une algue cultivée à l'obscurité depuis huit ans. *Compt. Rend. Acad. Sci. [Paris]* **172**: 254-260. 1921.
16. DASTUR, R. H. The relation between water content and photosynthesis. *Ann. Bot.* **39**: 769-785. 1925.
17. DASTUR, R. H., and B. L. DESAI. The relation between water-content, chlorophyll-content, and the rate of photosynthesis in some tropical plants at different temperatures. *Ann. Bot.* **47**: 69-88. 1933
18. DELEANO, N. T., and J. DICK. Beiträge zur Kenntnis des Carotins. *Bull. Soc. Chim. Romania* **14**: 117-170. 1932.
19. DEMEREC, M. Genetic relations of five factor pairs for virescent seedlings in maize. *Cornell Univ. Agric. Exp. Stat. Memoir* **84**. 38p. 1924.
20. EHRKE, GERHARD. Über die Wirkung der Temperatur und des Lichtes auf die Atmung und Assimilation einiger Meeres- und Süßwasseralgae. *Planta Arch. Wiss. Bot.* **13**: 221-310. 1931.
21. EHRKE, G. Über die Assimilation komplementär gefärbter Meeresalgae im Lichte von verschiedenen Wellenlängen. *Planta Arch. Wiss. Bot.* **17**: 650-665. 1932.
22. EMERSON, ROBERT. The relation between maximum rate of photosynthesis and concentration of chlorophyll. *Jour. Gen. Physiol.* **12**: 609-622. 1929.
23. EMERSON, ROBERT. Photosynthesis as a function of light intensity and of temperature with different concentrations of chlorophyll. *Jour. Gen. Physiol.* **12**: 623-639. 1929.
24. EMERSON, R., and W. ARNOLD. A separation of the reactions in photosynthesis by means of intermittent light. *Jour. Gen. Physiol.* **15**: 391-420. 1932.
25. EMERSON, R., and W. ARNOLD. The photochemical reaction in photosynthesis. *Jour. Gen. Physiol.* **16**: 191-205. 1932.
26. ENGELMANN, TH. W. Farbe und Assimilation. I. *Botan. Zeitung* **41**: 1-13, 17-29. 1883. (*See also* (a) *Ibid.* **42**: 80-93, 97-105. 1884.)
27. EULER, H. v., and H. HELLSTRÖM. Über die Bildung von Xanthophyll, Carotin, und Chlorophyll in belichteten und unbelichteten Gerstenkeimlingen. *Hoppe-Seyler's Zeitsch. Physiol. Chem.* **183**: 177-183. 1929.
28. EULER, H. v., *et al.* Spektrometrische Messungen an Carotinoiden. *Helvetica. Chim. Acta* **15**: 502-507. 1932.
29. GAFFRON, H. Über den Mechanismus der Sauerstoffaktivierung durch belichtete Farbstoffe. *Biochem. Zeitsch.* **264**: 251-271. 1933.
30. GAFFRON, H. Methoden zur Untersuchung der Kohlensäure-Assimilation. *Handbuch der Biologischen Arbeitsmethoden. E. Abderhalden. Abt. XI, Teil 4.* pp. 101-160.
31. GAFFRON, H. Über den Stoffwechsel der schwefelfreien Purpurbakterien. *Biochem. Zeitsch.* **260**: 1-17. 1933. (*See also* (a) *Ibid.* **269**: 447-453. 1934.)
32. GAIL, F. W. Photosynthesis in some of the red and brown algae as related to depth and light. *Publ. Puget Sound Biol. Sta.* **3**(66): 177-193. 1922.
33. GASSNER, G., and G. GOEZE. Über den Einfluss der Kaliernährung auf die Assimilationsgrösse von Weizenblättern. *Ber. Deut. Botan. Ges.* **50a**: 412-482. 1932.
34. GHOSH, J. C., and S. B. SEN-GUPTA. I. Absorption of light by solutions and suspensions of chlorophyll-a and chlorophyll-b and their mixtures. *Jour. Indian Chem. Soc.* **8**: 581-9. 1931.

35. GREGORY, F. G., and F. J. RICHARDS. Physiological studies in plant nutrition. I. *Ann. Bot.* **43**: 119-161. 1929.
36. GUTHRIE, J. D. Effect of environmental conditions on chloroplast pigments. *Amer. Jour. Bot.* **16**: 716-746. 1929.
37. HARDER, RICHARD. Review G. EHRKE. Über die Assimilation komplementär gefärbter Meeresalgen im Lichte von verschiedenen Wellenlängen. *Zeitsch. Botan.* **26**: 124-125. 1933.
38. HARDER, RICHARD. Über die Assimilation der Kohlensäure bei konstanten Aussenbedingungen. *Planta Arch. Wiss. Bot.* **11**: 263-292. 1930. (See also (a) Paper II. *Ibid* **20**: 699-733. 1933.)
39. HARDER, RICHARD. Bemerkungen über die Variationsbreite des Kompensationspunktes beim Gaswechsel der Pflanzen. *Ber. Deut. Botan. Ges.* **41**: 194-198. 1923.
40. HAUSSER, K. W. Lichtabsorption und Doppelbindung. *Zeitsch. Tech. Phys.* **15**: 10-20. 1934.
41. HEINRICHER, E. Zur Kenntniss der Algengattung Sphaeroplea. *Ber. Deut. Botan. Ges.* **1**: 433-450. 1883.
42. HENRICI, M. Chlorophyllgehalt und Kohlensäure-Assimilation bei Alpen- und Ebenenpflanzen. *Inaug. Diss. Basel.* 1918.
43. HENRICI, M. The Chlorophyll-content of grasses in Bechuanaland. *Reports of the Director of Veterinary Education and Research.* **11** and **12**: 259-271. 1927.
44. HOOVER, W. H., E. S. JOHNSTON, and F. S. BRACKETT. Carbon dioxide assimilation in a higher plant. *Smithsonian Misc. Coll.* **87** (16): 1-19. 1933.
45. JACCARD, P. Unaufgeklärte Schwankungen in der nächtlichen CO₂- Abgabe bei höheren Pflanzen. *Planta Arch. Wiss. Bot.* **19**: 713-728. 1933.
46. JACOBSON, C. A., and L. MARCHLEWSKI. Studien in der Chlorophyll gruppe. XIV. *Biochem. Zeitsch.* **39**: 174-184. 1912.
47. JOHNSTON, E. S. The functions of radiation in the physiology of plants. II. *Smithsonian Misc. Coll.* **87** (14): 1932.
48. KARRER, P., and W. SCHLIENTZ. Pflanzenfarbstoffe. LV. Zur Vorkommen von α - und β -Carotin in verschiedenen Naturprodukten. *Helvetica Chim. Acta.* **17**: 7-8. 1934.
49. KAUTSKY, H. Energie Umwandlungen an Grenzflächen. IV. (H. Kautsky und A. Hirsch.) Wechselwirkungen zwischen angeregten Farbstoff-Molekülen und Sauerstoff. *Ber. Deut. Chem. Ges.* **64**: 2677-2683. 1931.
50. KAUTSKY, H., A. HIRSCH, and F. DAVIDSHÖFER. Energie-Umwandlungen an Grenzflächen. VI. Kohlensäure-Assimilation (I). *Ber. Deut. Chem. Ges.* **65**: 1762-70. 1932.
51. KLUGH, A. B. Studies on photosynthesis of marine algae. *Contr. Canadian Biol. and Fisheries. N.S.* **6**: 43-63. 1930.
52. KLUYVER, A. J., and H. J. L. DONKER. Die Einheit in der Biochemie. *Chem. Zelle und Gewebe.* **13**: 134-190. 1926.
53. KNIEP, A., and F. MINDER. Über den Einfluss verschiedenfarbigen Lichtes auf die Kohlensäuerassimilation. *Zeitsch. Bot.* **1**: 619-650. 1909.
54. KOHL, F. G. Untersuchungen über das Carotin und seine physiologische Bedeutung in der Pflanze. Leipzig, 1902.
55. KOSTYTSCHEW, S. Lehrbuch der Pflanzenphysiologie. Berlin, 1926. p. 462.
56. KOSTYTSCHEW, S., K. BAZYRINA, and W. TSCHEBNOKOV. Untersuchungen über die Photosynthese der Laubblätter unter natürlichen Verhältnissen. *Planta Arch. Wiss. Bot.* **5**: 696-724. 1928.
57. KOSTYTSCHEW, S., W. TSCHEBNOKOV, and K. BAZYRINA. Untersuchungen über den Tagesverlauf der Photosynthese an der Küste des Eismeeres. *Planta Arch. Wiss. Bot.* **11**: 160-168. 1930.

58. KUHN, R., PAUL GYÖRGY, and THEO. WAGNER-JAUREGG. Über Lactoflavin, den Farbstoff der Molke. Ber. Deut. Chem. Ges. **66**: 1034-1038. 1933.
59. KUHN, R., A. WINTERSTEIN, and E. LEDERER. Zur Kenntnis der Xanthophylle. Hoppe-Seyler's Zeitsch. Physiol. Chem. **197**: 141-160. 1931.
60. KUHN, R. and ALEXANDER SMAKULA. Spektrophotometrische Analyse des Eidottersfarbstoffes. Hoppe-Seyler's Zeitsch. Physiol. Chem. **197**: 161-166. 1931.
61. KYLIN, HARALD. Einige Bemerkungen über Phykoerythrin und Phykocyan. Hoppe-Seyler's Zeitsch. Physiol. Chem. **197**: 1-6. 1931.
62. LASAREFF, P. Über die Absorption des Lichtes durch die Blätter der Pflanzen und die Absorption von Chlorophyllösungen. Biochem. Zeitsch. **182**: 131-133. 1927.
63. LI, TSI-TUNG. The immediate effect of a change of light on the rate of photosynthesis. Ann. Bot. **43**: 587-601. 1929.
64. LINDSTROM, E. W. Concerning the inheritance of green and yellow pigments in maize seedlings. Genetics **6**: 91-110. 1921. (See also (a) Cornell Univ. Agric. Exp. Sta. Memoir 83. 22 p. 1924.)
65. LIRO, J. I. Über die photochemische Chlorophyllbildung bei den Phanerogamen. Ann. Acad. Sci. Fennicae. A **1**: 1-147. 1909.
66. LLOYD, F. E. The fluorescent colors of plants. Science **59**: 241-248. 1924.
67. LUBIMENKO, V. Recherches sur les pigments des plastes et sur la photosynthèse. II. Rev. Gén. Bot. **39**: 547-559, 619-637, 698-710, 758-766. 1927.
68. LUBIMENKO, V. La biologie de la photosynthèse. III. Rev. Gén. Bot. **40**: 23-29, 88-94, 146-153, 226-243, 303-318, 372-381. 1928.
69. LUBIMENKO, V., and E. R. HUBBENET. The influence of temperature on the rate of accumulation of chlorophyll in etiolated seedlings. New Phytologist **31**: 26-57. 1932.
70. LUBIMENKO, W. Production de la substance sèche et de la chlorophyll chez les végétaux supérieur aux différentes intensités lumineuses. Ann. Sci. Nat. Bot. (9). **7**: 321-415. 1908.
71. LUBIMENKO, W. Influence de la lumière sur le développement des fruits et des grains chez les végétaux supérieurs. Rev. Gén. Bot. **22**: 145-175. 1910.
72. LUNDEGÄRDH, H. Der Kreislauf der Kohlensäure in der Natur. Jena, 1924.
73. LUNDEGÄRDH, H. Der Temperaturfaktor bei Kohlensäure-Assimilation und Atmung. Biochem. Zeitsch. **154**: 195-234. 1924.
74. MASKELL, E. J. Experimental researches on vegetable assimilation and respiration. XVIII. Proc. Roy. Soc. London B **102**: 488-533. 1928.
75. MATSUBARA, MASUTA. Die Verwendung der Beijerincksechen Indigweissmethode zu Quantitativen Assimilationsversuchen. Planta Arch. Wiss. Bot. **12**: 670-685. 1930-1931.
76. MECKE, R. Photochemical processes. Introductory paper. Trans. Faraday Soc. **27**: 359-375. 1931.
77. MECKE, R., and W. H. J. CHILDS. Trans. Faraday Soc. **27**: 514-515. 1931.
78. MEIER, FLORENCE E. Lethal action of ultra-violet light on a unicellular green alga. Smithsonian Misc. Coll. **87** (10): 1-9. 1932.
79. MESTRE, HAROLD. The investigation of the pigments of the living photosynthetic cell. (pp. 170-187.) Contributions to Marine Biology. Stanford Univ. Press, 1930.
80. MONTFORT, CAMILL. Fucus und die Physiologische Licht-Einstellung der Wasserpflanzen. I. Jahr. Wiss. Bot. **71**: 52-103. 1929. (See also (a) Ibid. **71**: 106-147. 1929.)
81. MÜLLER, D. Die Kohlensäureassimilation bei arktischen Pflanzen und die Abhängigkeit der Assimilation von der Temperatur. Planta Arch. Wiss. Bot. **6**: 22-39. 1928. (See also (a) Ibid. **16**: 1-9. 1932; (b) **16**: 10-15. 1932.)

82. MÜLLER, F. M. On the metabolism of the purple sulphur bacteria in organic media. Dissertation. Julius Springer; Berlin, 1933.
83. NEYDEL, KARL. Vergleichende Studien über die Wirkung des Lichtes und ansteigender Temperatur auf die CO_2 -Assimilation bei verschiedener Lichteinstellung. Biochem. Zeitsch. **228**: 451-486. 1930.
84. NOACK, K. Der Zustand des Chlorophylls in der lebenden Pflanze. Biochem. Zeitsch. **183**: 135-151. 1927.
85. NOACK, K., and W. KIESSLING. Zur Entstehung des Chlorophylls und seiner Beziehung zum Blutfarbstoff. Hoppe-Seyler's Zeitsch. Physiol. Chem. **182**: 13-49. 1929; **193**: 97-137. 1930.
86. NUERNBERGK, E. Physikalische Methoden der pflanzlichen Lichtphysiologie. Handb. Biolog. Arbeitsmethoden. (E. Abderhalden.) Abt. XI, Teil. 4. pp. 739-950. 1932.
87. OBERDORFER, ERICH. Lichtverhältnisse und Algenbesiedlung im Bodensee. Zeitsch. Bot. **20**: 465-563. 1927-28.
88. PADOA, M., and NERINA VITA. Über die Wirkung von Kohlenoxyd auf frische Pflanzen. Untersuchungen über die Absorptionsspektren der Chlorophylle *a* und *b* in Gegenwart von CO , N_2 , O_2 und CO_2 . Biochem. Zeitsch. **244**: 296-302. 1932.
89. PANTANELLI, E. Abhängigkeit der Sauerstoffausscheidung belichteter Pflanzen von äusseren Bedingungen. Jahr. Wiss. Bot. **39**: 167-228. 1903.
90. POKROWSKI, G. I. Über die Lichtabsorption von Blättern einiger Bäume. Biochem. Zeitsch. **165**: 420-426. 1925.
91. PRINGSHEIM, E. G. Kulturversuche mit Chlorophyllführenden Mikroorganismen. Beiträge Biol. Pflanzen. **12**: 1-48, 49-108. 1914.
92. PURIEWITSCH, K. Untersuchungen über Photosynthese. Jahr. Wiss. Bot. **53**: 210-254. 1914.
93. REINKE, J. Untersuchungen über die Einwirkung des Lichtes auf die Sauerstoffausscheidung der Pflanzen. Botan. Zeitung **42**: 1-10, 16-29, 33-46, 49-58. 1884.
94. REINKE, J. Die Abhängigkeit des Ergrünens von der Wellenlänge des Lichtes. Sitzber. K. Preus. Akad. Wiss. Math. Nat. Kl. **2**: 301-314. 1893.
95. RUDOLPH, H. Über die Einwirkung des Farbigen Lichtes auf die Entstehung der Chloroplastenfarbstoffe. Planta. Arch. Wiss. Bot. **21**: 104-155. 1934.
96. SAYRE, J. D. The development of chlorophyll in seedlings in different ranges of wavelengths of light. Plant Physiol. **3**: 71-77. 1928.
97. SCHANDERL, H., and W. KAEMPFERT. Über die Strahlungsdurchlässigkeit von Blättern und Blattgeweben. Planta. Arch. Wiss. Bot. **18**: 700-750. 1932.
98. SCHARFNAGEL, W. Biologische Untersuchungen zur Chlorophyllbildung. Planta Arch. Wiss. Bot. **13**: 716-744. 1931.
99. SCHIMPER, A. F. W. Untersuchungen über die Chlorophyllkörper und die ihnen homologen Gebilde. Jahr. Wiss. Bot. **16**: 1-247. 1885.
100. SCHMIDT, A. Die Abhängigkeit der Chlorophyllbildung von der Wellenlänge des Lichtes. Beitr. Biol. Pflanzen **12**: 269-294. 1914.
101. SCHMUCKER, TH. Über Assimilation der Kohlensäure in verschiedenen Spektralbezirken. (Die Energie Aufnahme als Quantenvorgang.) Jahr. Wiss. Bot. **73**: 824-852. 1930.
102. SCHNEIDER, ERICH. Chlorophyllartige Farbstoffe bei den Purpurbakterien. Ber. Deut. Bot. Ges. **52**: 96-100. 1934.
103. SENN, G. Die Gestalts- und Lagerungsveränderungen der Pflanzenchromatophoren. Leipzig. 1908.
104. SEYBOLD, A. Über die Optischen Eigenschaften der Laubblätter. I. Planta Arch. Wiss. Bot. **16**: 195-226. 1932. (See also (a) Paper II. Ibid. **18**:

- 479-508. 1932; (b) Paper III. *Ibid.* **20**: 577-601. 1933; (c) Paper IV. *Ibid.* **21**: 251-265. 1933.)
105. SHIBATA, K., and E. YAKUSHIJI. Der Reaktionsmechanismus der Photosynthese. *Naturwiss.* **21**: 267-268. 1933.
 106. SHIRLEY, H. L. The influence of light intensity and light quality upon the growth of plants. *Amer. Jour. Bot.* **16**: 354-388. 1929.
 107. SHULL, C. A. A spectrophotometric study of reflection of light from leaf surfaces. *Botan. Gaz.* **87**: 583-607. 1929.
 108. SJÖBERG, K. Beitrag zur Kenntnis der Bildung des Chlorophylls und der gelben Pflanzenpigmente. *Biochem. Zeitsch.* **240**: 156-186. 1931.
 109. SMITH, J. H. C. The yellow pigments of green leaves: their chemical constitution and possible function in photosynthesis. *Contributions to Marine Biology*. Stanford Univ. Press, 1930.
 110. SMITH, J. H. C., and H. W. MILNER. Carotene VII. Physical properties of carotenes from different plant sources. *Jour. Biol. Chem.* **104**: 437-447. 1934.
 111. SPOEHR, H. A., and J. M. MCGEE. Studies in plant respiration and photosynthesis. *Carnegie Institution of Washington, Pub. No. 325*. 1923.
 112. STAIR, R., and W. W. COBLENTZ. Infra-red absorption spectra of some plant pigments. *Bureau Standards Jour. Res.* **11**: 703-711. 1933.
 113. STÄLFELT, M. G. Periodische Schwankungen im Chlorophyllgehalt wintergrüner Pflanzen. *Planta Arch. Wiss. Bot.* **4**: 201-213. 1927.
 114. STOLL, A. Über den chemischen Verlauf der Photosynthese. *Naturwiss.* **20**: 955-958. 1932.
 115. STOLL, A. Ein Gang durch biochemische Forschungsarbeiten. Berlin, 1933.
 116. STOLL, A., and E. WIEDEMANN. Der Verlauf der Phasenprobe und die Konstitution von Chlorophyll *a* und Chlorophyll *b*. *Naturwiss.* **20**: 706. 1932.
 117. STOLL, A., and E. WIEDEMANN. Über die Kernstruktur des Chlorophylls und seine katalytische Hydrierung. *Naturwiss.* **20**: 791. 1932.
 118. STOLL, A., and E. WIEDEMANN. Überführung von Chlorophyll *b* in Chlorophyll *a*. *Naturwiss.* **20**: 889. 1932.
 119. STOLL, A., and E. WIEDEMANN. Über Chlorophyll *a*, seine phasepositiven Derivate und seine Allomerisation. *Helvetica Chim. Acta* **16**: 739-772. 1933. (*See also* (a) *Ibid.* **16**: 307-314. 1933.)
 120. TAYLOR, H. S. Second Report of the Committee on Photochemistry, Division of Chemistry and Chemical Technology, National Research Council. *Jour. Phys. Chem.* **34**: 2049-2091. 1930.
 121. TREBOUX, O. Zur Stickstoffernährung der grünen Pflanze. *Ber. Deut. Botan. Ges.* **22**: 570-572. 1904.
 122. URSPRUNG, A. Die physikalischen Eigenschaften der Laubblätter. *Bibliog. Botan.* **60**. 1903.
 123. URSPRUNG, A. Über die Stärkebildung im Spektrum. *Ber. Deut. Botan. Ges.* **35**: 44-69. 1917.
 124. URSPRUNG, A. Über die Absorptionskurve des grünen Farbstoffes lebender Blätter. *Ber. Deut. Botan. Ges.* **36**: 73-85. 1918.
 125. VAN DEN HONERT, T. H. Carbon dioxide assimilation and limiting factors. *Rec. Trav. Bot. Néerland.* **27**: 149-284. 1930.
 126. VAN DER PAAUW, F. The indirect action of external factors on photosynthesis. *Rec. Trav. Bot. Néerland.* **29**: 500-620. 1932.
 127. VAN GULIK, D. Über das Absorptionsspektrum des Chlorophylls II. *Ann. Phys.* (4) **46**: 147-156. 1915.
 128. VAN GULIK, D. Über das ultraviolette Absorptionsspektrum des Chlorophylls. *Ann. Phys.* (5) **4**: 450-452. 1930.
 129. VAN NIEL, C. B. On the morphology and physiology of the purple and green sulphur bacteria. *Archiv. Mikrobiol.* **3**: 1-113. 1931. (*See also* (a) *Ibid.*

- Report, Carnegie Institution of Washington, Year Book No. 32, p. 184. Washington, 1933.)
130. VAN NIEL, C. B., and F. M. MULLER. On the purple bacteria and their significance for the study of photosynthesis. *Rec. Trav. Bot. Néerland.* **28**: 245-274. 1931.
 131. VOERKEL, S. II. Untersuchungen über die Phototaxis der Chloroplasten. *Planta Arch. Wiss. Bot.* **21**: 156-205. 1933.
 132. WAGNER-JAUREGG, TH. Über die optische Aktivität des Phytols. *Hoppe-Seyler's Zeitsch. Physiol. Chem.* **222**: 21-23. 1933.
 133. WARBURG, O. Über die Geschwindigkeit der photochemischen Kohlensäurezersetzung in lebenden Zellen. *Biochem. Zeitsch.* **100**: 230-270. 1919. (*See also* (a) *Ibid.* **103**: 188-217. 1920.)
 134. WARBURG, O. Versuche über die Assimilation der Kohlensäure. *Biochem. Zeitsch.* **166**: 386-406. 1925.
 135. WARBURG, O. Über die Katalytische Wirkungen der Lebendigen Substanz. Julius Springer; Berlin, 1928.
 136. WARBURG, O. The application of the photochemical equivalent law to vital processes. *Trans. Faraday Soc.* **27**: 551-554. 1931.
 137. WARBURG, O., and E. NEGELEIN. Über den Einfluss der Wellenlänge auf den Energieumsatz bei der Kohlensäureassimilation. *Zeitsch. Phys. Chem.* **106**: 191-218. 1923.
 138. WARBURG, O., and T. UYESUGI. Über die Blackmansche Reaktion. *Biochem. Zeitsch.* **146**: 486-492. 1924.
 139. WIESNER, J. Die Entstehung des Chlorophylls in der Pflanze. Wien, 1877.
 140. WILLSTÄTTER, R. Zur Erklärung der Photoreduktion von Kohlensäure durch Chlorophyll. *Naturwiss.* **21**: 252. 1933.
 141. WILLSTÄTTER, R., and W. MIEG. Über die gelben Begleiter des Chlorophylls. *Ann. Chem.* **356**: 1-28. 1907.
 142. WILLSTÄTTER, R., and A. STOLL. Untersuchungen über Chlorophyll. Berlin, 1913.
 143. WILLSTÄTTER, R., and A. STOLL. Untersuchungen über die Assimilation der Kohlensäure. Berlin, 1918.
 144. WINTERSTEIN, A. Fraktionierung und Reindarstellung von Pflanzenstoffen nach dem Prinzip der chromatographischen Adsorptionsanalyse. G. Klein, Handbuch der Pflanzenanalyse IV 2. pp. 1403-1437. Julius Springer; Wien, 1933.
 145. WINTERSTEIN, A., and GERTRUD STEIN. Fraktionierung und Reindarstellung organischer Substanzen nach dem Prinzip der chromatographischen Adsorptionsanalyse. II. Chlorophylle. *Hoppe-Seyler's Zeitsch. Physiol. Chem.* **220**: 263-277. 1933.
 146. WLODEK, J. Recherches sur l'influence de la lumière et des engrais chimiques sur le coefficient chlorophyllien. *Bull. Acad. Polonaise Sci. et Let. Class Sci. Math. et Nat. Ser. B.*, 1921. 143-190; 1920. 19-52.
 147. WLODEK, J. Spectrum of chlorophyll in the living leaf. *Chem. Abst.* **19**: 2687. 1925.
 148. WURMSER, RENÉ. La loi l'équivalent photochimique dans la photosynthèse chlorophyllienne. *Jour. Phys. et Le Radium, Ser. VI*, **7**: 33-44. 1926.
 149. WURMSER, RENÉ. The energetic efficiency of photosynthesis. *Nature* **124**: 912-913. 1929.
 150. YABUSOE, MUNEO. Über den Temperaturkoeffizienten der Kohlensäureassimilation. *Biochem. Zeitsch.* **152**: 498-503. 1924.
 151. YAKUSHIJI, E. Über die Katalase und ihre Rolle im Reaktionsmechanismus der Photosynthese. *Acta Phytochim.* **7**: 93-115, 1933.

152. YOSHII, YOSHIJI. Untersuchungen über die Temperatur-abhängigkeit der Kohlensäure-assimilation bei Bohnen. *Planta Arch. Wiss. Bot.* **5**: 681-695. 1928.
153. ZSCHEILE, F. PAUL. An improved method for the purification of chlorophylls *a* and *b*; quantitative measurement of their absorption spectra; evidence for the existence of a third component of chlorophyll. *Bot. Gaz.* **95**: 529-561. 1934.
154. ZSCHEILE, F. PAUL. Investigation of the fluorescence spectra of chlorophylls *a* and *b* in ether solution. Private communication.

Manuscript received by the editor July, 1934.

XXXII

THE INFLUENCE OF RADIATION ON PLANT RESPIRATION AND FERMENTATION

CHARLES J. LYON

Department of Biology, Dartmouth College

*Introduction. Influence of radiation on respiration. Radiation and fermentation.
Summary. References.*

INTRODUCTION

In general, the influence of radiant energy on katabolic processes is incompletely understood because of lack of proper experimentation in the field. Either the necessary tests have not been carried out or the experiments have been so inadequate in number or precision that the results are inconclusive or unreliable. This is not strictly true for all types of radiation, however, and in the following paragraphs distinctions are made as definitely as possible between well-supported evidence and that based on only a few experiments. These distinctions have been made even at the risk of injustice to some workers, but it is hoped that such errors will be excused in the interests of a conservative estimate of results obtained in a difficult field of experimentation.

INFLUENCE OF RADIATION ON RESPIRATION

Light.—The attempts to measure the influence on respiration of radiation from sources of light have resulted in the accumulation of a mass of inconclusive and contradictory evidence. In general, the earlier results pointed to a decrease in intensity of respiration as measured by production and release of CO₂ while later and more careful experimentation has indicated the absence of any direct effect of the visible rays.

These analyses have been exceedingly difficult and in fact limited almost entirely to nongreen plants because of the simultaneous action of light in photosynthetic processes. At the same time, there has been a regrettable failure, even in some of the work of recent years, to make the conditions of the experiments such as to preclude the influence of radiation other than that of the visible spectrum. Consequently the results are decidedly inconclusive, although it seems evident that there can be no appreciable direct effect of light on normal respiration.

Work reported previous to 1902 may be passed over with safety because it was so fragmentary and inexact. It is carefully and fairly

reviewed by Maximow (12) who took notice of representative papers published previous to his time. Those of which he did not write give the same contradictory results based on inadequate experiments. For example, he omitted reference to numerous experiments by Day (4) with germinating seeds of barley and wheat. Barley was reported to show 3 to 4 per cent more respiration in diffuse daylight than in darkness, as measured by O_2 consumption and CO_2 production. The variations in measurements were great and the differences in favor of light were not significant.

Maximow contributed the first complete analysis of the problem with proper regard for experimental methods and justifiable conclusions. He used the lower fungi (such as *Aspergillus*) for plant material, an electric light with and without a reflector as a source of light, and controlled the temperature of his cultures by means of a water bath and thermostat. He was careful to provide sufficient organic food for the life of the mold and to eliminate the variables due to changing growth rates of cultures at different ages.

Maximow concluded that the response to light depends on the age of the fungus, with young cultures unaffected by visible rays from an electric light. Older cultures show a small but short-lived acceleration of respiration which is more pronounced if the mycelium is undernourished. The failure of this initial acceleration to continue for more than a few minutes led Maximow to the conclusion that light has little or no direct effect upon respiration.

A few years later Löwshin (9) performed numerous experiments with the same type of plants and with due consideration of temperature and nutritive relations. He used diffuse daylight and reported that he never found a real increase in rate of respiration which was not caused by rise in temperature of the culture.

Finally, we have the recent work of de Boer (3) with fungi, using modern apparatus, which led him to conclude that there is no direct influence of the visible spectrum on the respiration of these plants. His methods and precautions are beyond criticism. He measured both O_2 and CO_2 as well as the intensity of illumination. When he found no response to light by *Phycomyces blakesleeanus*, he turned to other fungi. He used small fruiting bodies of mushrooms, pure cultures of their mycelia, and a growth of *Polyporus destructor* on carrot slices. In all cases his measurements showed a complete lack of response to light. The table, top of page 1061, is typical of his data and of the accuracy of his analyses.

It must be mentioned that there is a still more recent report of an increase in rate of respiration in a nongreen leaf of *Croton* as the result of exposure to artificial light. This effect is described by Ranjan (15) on the basis of two experiments with excised leaves contained in a glass

TABLE 1.—DATA FROM DE BOER

Using 20 very small specimens of *Laccaria amethysta*; respiration vessel 325 cc.; suction velocity (Air Circulation) 3 liters per hr.

(3, cf. Table 21, page 211)

Time	CO ₂ evolved, cc.
From 10.00 to 12.00	→ 4.5
From 12.00 to 14.00	→ 4.35
From 14.00 to 16.00	→ 4.35 ← light of 800 MC.
From 16.00 to 18.00	→ 4.35
From 18.00 to 20.00	→ 4.5 ← light of 6000 MC.
From 20.00 to 22.00	→ 4.35

vessel submerged in a water bath held at 35°C. by a thermostat. However, the number of measurements is so small and the acceleration reported is so slight that the evidence is not convincing. Still it should be noted that this work was done with an organ of a vascular plant, while practically all the tests reported above were confined to fungi. It is still possible that this difference in behavior will be confirmed by future experiments which need to be performed before a general conclusion can be reached. The slight increase reported by Day (4) with germinating grain should be checked by tests with modern apparatus and attention to the influence of growth rates. Flowers without green parts or marked phototropic responses should also be subjected to careful tests and it is possible that etiolated plants or seedlings grown in darkness on solutions of organic compounds could be tested by exposure to light which would be too brief to cause development of chlorophyll before a response to illumination could be detected.

There is a possible indirect effect of illumination on respiration, first brought to our attention by Spoehr (20) who showed that air ionized by the sun's rays gave a slightly greater rate of respiration than night air or deionized air. Spoehr's theory was given support by the work of Middleton (13) with barley seedlings and Whimster (24) with leaves of *Pelargonium*, but not by that of Sapozhnikova (18) with wheat seed or of de Boer (2) with fungi. In any case the effect is small and indirect.

A specific photochemical effect of light on the respiration of yeast checked by carbon monoxide was demonstrated by Warburg (22) and confirmed by Keilin (7). When the respiration is stopped by CO, the latter forms a chemical union with the oxidase system and either light from a 50-candle power light or daylight will release the CO and allow respiration to proceed. The short wave-lengths are more active while the red rays are inactive.

This effect for a pathological condition has no influence on the general conclusion that light does not affect the respiration of plants (except for the incompletely tested possibility that tissues of the higher plants are slightly affected) other than through the increased supply of carbohydrates produced by simultaneous photosynthesis in green tissues.

Ultra-violet Rays.—Of the relationship between respiration and ultra-violet radiation we have almost no knowledge because the necessary experiments have not been performed. There has been but one report of measurements in this field, and even before it has been repeated by others, there has been adverse criticism of its conditions and technique by Popp and Brown (14, pages 169–171) in their critical analysis of recent work with ultra-violet.

The report in question was made by Masure (11) who used germinating pea seeds and screened radiation from a mercury-vapor lamp. The Corning G586AW screen was said to transmit chiefly rays in the region 3650 Å, which is not far below the visible rays at 4000. However,

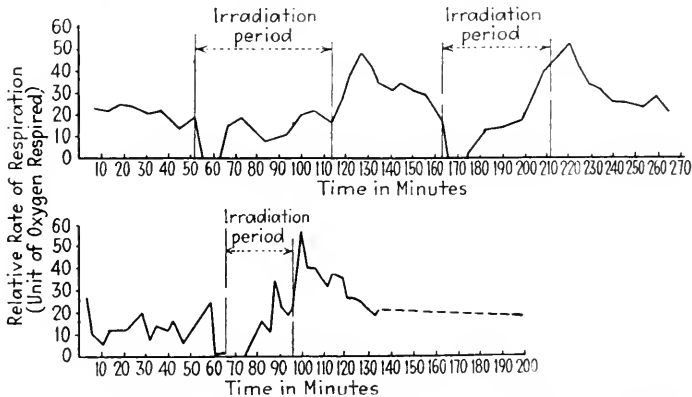

FIG. 1.—Effect of raying on the rate of respiration of etiolated pea seedlings. (After Masure, 11.)

Popp and Brown claim that this filter also transmits infra-red even better than ultra-violet and thus challenge any evidence derived from its use as a test of the influence of ultra-violet on either growth or respiration.

The results obtained by Masure for the effect on respiration are shown in the above graph taken from his paper. It shows clearly that the rate of respiration is temporarily increased by the rays which pass the filter and ultra-violet is at least a part of this effective radiation. Its effects disappear soon after it is discontinued. The preliminary drop in respiration soon after the radiation is applied is said by Masure to represent an expansion of the seeds as they are heated by the rays which they absorb. This is possible because the respiration is measured as O_2 consumption read from the movement of a column of liquid in equilibrium with the gas pressure within the experimental chamber. However, this heat effect must also influence the production of CO_2 and the consumption of O_2 throughout the period of irradiation.

Only two of these experiments have been reported. In view of the small amount of evidence here and the lack of confirmation of it elsewhere it must be said that we do not know yet just how ultra-violet

radiation does influence respiration. However, this reported increase agrees with the effect of ultra-violet on alcoholic fermentation which is often pronounced in pea seeds, especially during the early stages of germination when there is a shortage of O_2 within the seed coats.

X-rays.—The group of waves known as roentgen or X-rays have been tested rather carefully on two types of plants for their effect on respiration but the results are in part contradictory. They indicate either no influence with nondestructive doses or a depression of the respiratory intensity, especially with doses which are so injurious as to prevent continued growth of the plants involved.

The work which points to no effect on respiration, even though growth and reproduction are severely retarded at the same time, was reported by Wels and Osann (23) in 1925, though the senior author had reported like results from a few experiments in the preceding year. The plant used for the main report was yeast and the respiration was measured by the O_2 consumption in a Barcroft manometer a few hours after irradiation. The experimental technique for handling the X-rays and attention to such details as proper temperature control of the irradiated yeast suspension appear to warrant confidence in the data obtained. Even though the periods of exposure to the rays were from 2 to 8 hr. with such a strength of radiation that 1 hr. was equivalent to 12 units of the human erythema dose (denoted as H.E.D.), there was no change in the rate of oxygen consumption, at least when it was measured. At the same time, the rate of increase of yeast cells decreased in proportion to the length of the exposure.

This positive effect indicates that the X-rays were actually absorbed by the yeast cells. Likewise the absence of change in the rate of fermentation (see next section of this paper) under the same conditions suggests that the oxygen consumption is a fair measure of the respiration in these cells because of the close relationship between alcoholic fermentation and normal plant respiration. However, Schneider (19) reported a 10 per cent decrease in fermentation by yeast exposed to a dose of 3 H.E.D. *during the actual process*, so that an element of uncertainty is present even in these otherwise conclusive results. The critical test would be to measure the O_2 consumption under conditions unfavorable to fermentation and at the same time expose the yeast to X-rays. This has not been done.

The retardation of respiration by X-rays has been demonstrated in seeds and seedlings by two workers, Bersa (1) in Austria and Miss Johnson (6) in the United States. The latter reported only a depression but she used strong doses for a "few" hours. Bersa found a brief, slight acceleration with much weaker doses, but after 2 or 3 days the rate of respiration had fallen to about 57 per cent of the normal. Both workers exposed moist seeds and measured the results in the growing seedlings,

but one of these measured the O₂ consumption and the other followed the production of CO₂. Thus their results are supplementary and practically identical and together form a sound basis for belief in a depressant effect on the respiration of higher plants, at least.

Miss Johnson (6) used seeds of *Helianthus annuus* before they had lost any great amount of their water, which was found to be 58.7 per cent of the weight of the seeds. She found it necessary to use doses of from 1 to 5 H.E.D. to affect the seeds, of 10 H.E.D. to inhibit growth to any extent, while a 20-H.E.D. dose on the seeds produced seedlings which died just as the cotyledons started to emerge from the soil. Higher doses of 24 and 40 H.E.D. were used in the tests for which the changes in respiration were measured. The following is the result of one experiment while only four experiments in all were performed:

TABLE 2

Dose 24 H. E. D.	Mg. CO ₂ per gm. dry weight of seedling per hour	
	Irradiated	Control
78-hr. seedling.....	1.742	3.043
102-hr. seedling.....	3.369	4.317

The experiments conducted by Bersa (1) were numerous, the technique accurate, and the evidence is convincing. The seeds used were those of *Vicia Faba* and the exposures of from $\frac{1}{5}$ to 2 H.E.D. were made on good seeds soaked in water for two days by which time they had burst their seed coats. The tests for respiration, as measured by oxygen consumption, were made on the excised root tips removed in small lots at certain intervals. Doses of $\frac{1}{5}$ H.E.D. had no effect on respiration. In most of the experiments the dose was 1 H.E.D. and in Fig. 2 there is given a composite graph to show its effect on the rate of respiration of primary root tips for hours after the seeds were irradiated.

The dotted lines indicate, by their distances from the solid line, the probable errors of the measurements which showed decided fluctuations, especially for those made after 2 or 3 days.

The difference in these results for higher plants, in comparison with the influence of X-rays on lower plants as represented by yeast, must be left without explanation until more evidence has been produced. The conclusions for the influence on the higher plants seem to be based on better developed evidence, if anything, than that for the lower plants, which have been represented only by yeast and this is hardly typical of the group as a whole. If assumptions must be made concerning the metabolism of an untried plant, it would appear to be safer to expect a

depressant effect of X-rays on respiration, especially if the doses are as great as 5 H.E.D.

Radium Radiations.—Except for the slightly absorbed gamma rays, the radiation from radium compounds is entirely different in nature from light, ultra-violet, and X-rays, yet it must be considered for its possible influence on respiration, partly because of its natural occurrence to some extent. Of the other two types of radiation—the alpha and beta particles—the former is so completely absorbed by the glass containers of the radium salts that its effects are not involved in the ordinary use of radium and are therefore considered elsewhere in this report. The beta particles are left as a possible factor in the exposure of plant tissue to radium.

For evidence of the relation of these particles to respiration we have a few series of tests in which suitable observations were taken and conclusions drawn, but it is very difficult to compare these results and to reach a general conclusion as to the effect on plant respiration. The variations in the sources of the

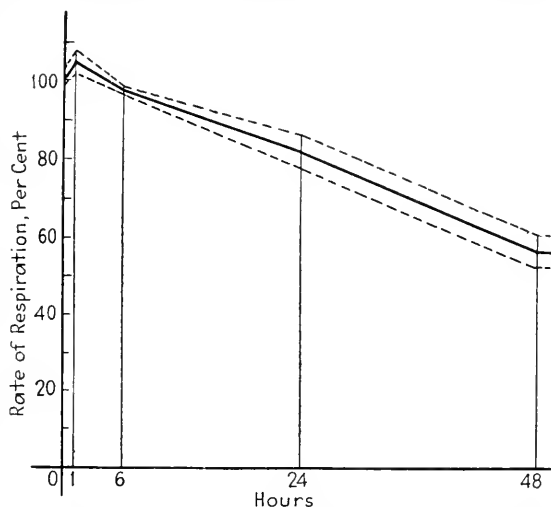

FIG. 2.—Root tips of *Vicia Faba*; graphic representation of rate of respiration after radiation with X-rays at 1 H.E.D. Time in hours after irradiation is shown as abscissas and rate of respiration compared with the control (100) is shown as ordinates. Dotted lines represent averages of the probable error. (After Bersa, 1.)

radiations, the degree of absorption in the several cases, the distance between source and tissue, the organ and species of plant used, the length of exposure, the time between exposure and measurement of effect, etc., are so great and their bearing on the data so important that only qualitative statements can be made here. Briefly stated, the effect of beta particles appears to be a lowering of the rate of respiration more or less in proportion to the length of exposure except for a temporary acceleration of the rate if the exposure is very short.

The first study of the influence of radium on respiration was reported briefly by Hébert and Kling (5) in 1909. They found a marked depression in the rate of respiration of lilac leaves, at least if the leaves showed injury from the exposure. Both O_2 and CO_2 changes were measured, but the data were given for only a very few experiments.

The next test of the action of beta particles was made by Redfield and Bright (16) who used unsoaked radish seeds and measured their CO_2 pro-

duction in a "moistened" but not germinating condition "2 days after radiation." Although the power to germinate was decreased by the treatment, the production of CO_2 was increased. This acceleration must not be granted much emphasis, however, because it may not have been a direct result of radiation. It might well have been an indirect effect due to increased rate of entry of water through the irradiated seed coats in comparison with the absorption of water by the control seeds. The seeds were not thoroughly soaked in water and a small difference in water content at that point would account for a great difference in rate of respiration.

The length of exposure to the radium, the quantity and nature of the radium salt used, the time required to measure the respiration after moistening the seeds, and similar details of the experimental procedure are wholly lacking in the report of results. The fact that germination was decreased to at least 25 per cent of that of the control seeds indicates a powerful action on the seed embryos, but the rate of respiration at any time after irradiation does not seem to have been fairly measured.

The best and only thorough study of the influence of beta particles on plant respiration is that by Reich (17) reported in 1926. He used chiefly dry seeds of *Pisum* which were exposed for various time intervals to the radiation from 5 mg. of radium chloride in a glass tube held 8 mm. from the seeds. The meristem of each embryo was turned toward the radium except in a few tests for exposure from the rear. After irradiation, the seeds were soaked in water for 18 to 24 hr. and their CO_2 production was then measured at intervals of 5 to 7 hr. for the next few days, with the ruptured seed coats removed. In the few tests with seeds soaked before irradiation, the results were the same except that shorter exposures were required to produce the same results as in dry seeds.

The conclusions from these extensive tests, which also included measurements several months after irradiation, were in favor of a marked depression in respiration. This injurious effect became even more pronounced with a lapse of time during which the seedlings continued to grow. Dry seeds were found more resistant to exposure than soaked seeds. The cotyledons were influenced slightly but the principal effect was felt by the rest of the embryo.

A temporary acceleration which was in evidence for a few days was obtained with exposures of 2 hr. or less. For exposures under $\frac{1}{2}$ hr. and with dry seeds, the preliminary accelerations of from 1 to 50 per cent later disappeared to leave the respiration rate normal for the next few days. With exposures of over $\frac{1}{2}$ hr., a depression in rate eventually appeared and its extent was in proportion to the length of the exposure.

It must be emphasized again that these conclusions for radium radiations, with the alpha particles eliminated and with little or no effect from the gamma rays, are only qualitative. Moreover, they are

based largely on the data reported by Reich from numerous but unconfirmed experiments with one organ of a single species of plant.

As for the physical basis of this effect by beta particles, there has been a report by Stoklasa and Pěnkava (21) which contains a suggestion. Contrary to the evidence just cited, they seem to believe that radium radiation increases the rate of respiration, but this may only correspond to the temporary acceleration from short exposures, for they used very small amounts of radioactive compounds. It is their claim that the beta particles act on the glycolytic enzymes and thus cause the intermediate labile products of respiration to be oxidized more rapidly. In support of this idea they point out that forms which show the highest rates of respiration are also richest in potassium salts.

This discussion may have an important bearing on the normal processes of cellular respiration, but the amount of radium radiation involved is so small in plants and in the experiments of Stoklasa and Pěnkava that the results are hardly comparable with those of other workers. However, if it be true that there is an effect on certain enzymes, the depression in respiration reported for the seeds and seedlings as the results of exposure to strong radium radiation may be due to a result akin to fatigue or an injured enzymatic mechanism within the irradiated cells.

Heat Effects.—In addition to radiation by waves of the length of visible light or shorter, it is also possible for longer waves to influence plant respiration. This is the familiar heating effect of waves of these lengths, including the infra-red. However, it is also possible for the shorter waves to give the same effect if and when their radiant energy is transformed into heat.

The influence of this heat upon respiration is so well known and appreciated that little need be said about it here. The resultant increase in temperature within the tissue which interrupts and absorbs this radiant energy always causes an increase in the rate of respiration up to the point where the protoplasm is injured or killed by the high temperature. In any experiment in which radiant energy is absorbed by the plant material or container, provision must be made to remove the heat thus trapped, by the use of some device like a water bath to insure constant temperature. If infra-red or longer waves are emitted by the source of radiation, such as a mercury-vapor lamp for ultra-violet, such waves can and should be filtered out by a water cell or similar material which will transmit the desired waves but not those longer than light waves.

The quantitative statement of this heating effect is contained in any one of the temperature coefficients, of which the Q_{10} ratio of the van't Hoff equation has the widest usage. For respiration, the Q_{10} or ratio of rates at two temperatures which differ by 10°C . is between 2 and 3, as

for most reactions which involve organic compounds. This means that the reaction velocity or rate of respiration is at least doubled for each 10° rise in temperature, but at all temperatures above 20°C . the Q_{10} ratio tends to become progressively smaller as the temperature rises. The exact influence of heat, therefore, depends in part on the specific heats of all substance involved but such differences are merely quantitative.

RADIATION AND FERMENTATION

The only phase or type of fermentation which has been studied for its relations with the various forms of radiant energy is alcoholic fermentation. Although this process is associated with other genera of plants, the few observations reported have all been made for yeast. The three forms of radiation which have been tested thus far are visible light, ultra-violet and X-rays. In addition, the heat effect will be discussed only briefly because it is not essentially different for this special phase of katabolism.

Light.—Although others have observed the relation of cell division in yeast to its illumination, with a general agreement that a bright light source retards the production of new cells, there have been only two reports of the effect on fermentation itself. The first was a dissertation by Lohmann in 1896. The second was made by Lubimenko and Froloff-Bagreief (10) in 1912. Since the latter is more available and definitely confined to the question of fermentation as opposed to cell division, it will be used as a basis of discussion. These workers agreed with the findings of Lohmann and included additional precautions to observe the direct effect of the radiation on the process of fermentation.

The conclusion is that light retards fermentation. This is the natural result, since it also reduces the number of cells available to produce CO_2 and alcohol and a part of the effect is due to this relationship. However, Lubimenko and Froloff-Bagreief claim, from results not published in detail, that some of the effect is an actual lowering of the rate of fermentation. They also report less glycerin and more acid in their tests with raisin must. The depression in the fermentation rate is said to be more pronounced as the temperature is increased.

Since this conclusion is not in accord with the effect of light on respiration and because the only data available have been incompletely reported, the result is far from conclusive. The experiments must be repeated for yeast and likewise performed with other causal agents of fermentation.

Ultra-violet Rays.—For the effect of these short waves on fermentation we have the recent work of Lindner (8) who undertook to repeat the pioneer test made by Fazi in 1915. Because of the improved technique of Lindner, his results are the first real proof of a remarkable acceleration of fermentation by the radiation from a mercury-vapor lamp. The temperature was not held constant but the change in rate of CO_2 pro-

duction of the irradiated mixture of glucose, water, and a bottom yeast was so great that the temperature fluctuation of 3° or 4°C. was of no importance, especially since the rise in temperature was nearly as great in the control flask.

It should be noted that the rather brief report of this work by Lindner makes no mention of a screening of the radiation from the lamp and it is probable that other rays entered the quartz flask in which the fermentation took place. The heating effect of the infra-red appears to have been practically eliminated, but there is some uncertainty as to what participation other rays may have had in the effect. However, the effect is so great that at least a part must be due to the ultra-violet rays. Possible direct action on the glucose was eliminated by suitable tests. Furthermore, study of the condition of the irradiated yeast cells after 24 hr. exposure showed that 20 to 30 per cent of them are injured or killed, as though they had been worked out by the high rate of fermentation.

The data are given for only a single experiment. A solution of 30 gm. of glucose in 300 cc. of water was inoculated with 5 gm. of pressed yeast and allowed to stand for 10 hr. before the experiment began. A control mixture was treated in the same way and its CO₂ production measured simultaneously with that of the mixture exposed to the lamp. The results were evident from the start as Table 3 shows:

TABLE 3

Hours from start	CO ₂ production, cc.	
	Irradiated	Control
2	156	4
4	645	118
6	1085	119
8	1475	119
10	1749	119
12	1929	119
14	2113	119
16	2265	119
18	2395	119
24	2743	119

Other tests are reported on the action of the radiation on beer wort inoculated with this same yeast. The differences in favor of the irradiated yeast were less than for glucose solutions but were still convincing and consistent. Until more precise tests are made, especially by the use of suitable filters, it may be assumed that there is some unusual effect of ultra-violet on fermentation, possibly related to the similar effect on the respiration of pea seedlings.

X-rays.—The yeast plant has been exposed to X-rays both before and during the process of fermentation and with results which seem to depend upon just this factor of time of exposure. These experiments were described in their essentials in the preceding section because the same workers tested both respiration and fermentation with the same apparatus. Since the reports were published in the same year, they appear to be independent and mutually supported, although differing somewhat in the details of procedure.

Wels and Osann (23) decided that fermentation itself is unaffected, even by strong doses of X-rays, although both growth and reproduction of the yeast is retarded. The CO₂ production was measured with a Barerofft manometer and suitable precautions appear to have been taken for such important items as temperature control and the technique of handling the X-rays. These experiments had the characteristic, however, of measurement of CO₂ a few hours after the period of exposure.

The importance of this point appeared in the work of Schneider (19) who reported a 10 per cent reduction in fermentation *when the X-rays were being applied*. The curve of CO₂ production of unirradiated yeast coincided with that of yeast exposed some time before measurement, a result in harmony with that of Wels and Osann. Schneider further studied the action of the X-rays by tests to determine other factors which might influence the effect. He found that an important factor was the medium surrounding the yeast cells. The depression in fermentation appeared only in the presence of electrolytes such as NaCl and MgCl₂.

Again we are forced to draw conclusions of a relationship between a process and a form of radiation on the basis of a single set of unconfirmed experiments. The point is clearly in need of more study, but provisionally we may assume a small reduction in rate of alcoholic fermentation during exposure to X-rays.

Heat Effects.—The application of heat to a fermentation mixture has two distinct effects—that of increasing the number of yeast cells and the separate effect on the actual rate of fermentation. To measure or study the latter alone it is necessary to use a short experiment with a relatively large amount of yeast and sugar solution. Of course, the effect is the same in any experiment, but this is the only practical method of avoiding large errors due to the presence of greater numbers of yeast cells.

When these precautions have been taken, we find that rise in temperature has the same effects that it does on most biological processes with a predominant chemical basis. There is a certain range of temperature throughout which fermentation will take place, an optimum temperature and an effect on the rate of fermentation which is stated by some form of temperature coefficient. In any experiment with fermentation and radiant energy they must be considered, although the use of a con-

stant temperature apparatus reduces the considerations to the single point of deciding at what temperature the process should be kept. In some cases it may be necessary to use more than one temperature in order to cover all possible variations.

The working range of temperature for yeast and alcoholic fermentation is 0° to 50°C. with the optimum at or near 30°. The temperature coefficient (Q_{10}) is thought to be about 2, as would be expected for a process so clearly based on a series of chemical transformations. Of course, in their relations to other forms of experimentation with fermentation, these data emphasize the need of careful control of temperature during any series of measurements or growth tests.

SUMMARY

As an aid in picturing the direct effects of radiation upon plant metabolism, the more or less well supported conclusions are stated by short phrases in the following table:

Type of radiation	Respiration	Alcoholic fermentation
Light.....	No effect with lower plants; possible slight acceleration with higher plants	Retards action by yeast
Ultra-violet.....	Temporary acceleration for higher plants	Marked acceleration
X-rays.....	No critical test made for lower plants; depression for higher plants	Small decrease in rate during exposure
Radium.....	Depression by beta particles for higher plants	No information
Heat effects.....	Acceleration by rise in temperature	Acceleration by rise in temperature

REFERENCES

1. BERSA, E. Strahlenbiologische Untersuchungen III. Über den Einfluss der Röntgenstrahlen auf die Atmung der Wurzelspitzen von *Vicia faba*. Sitzungsber. Akad. Wiss. Wien. Math-Naturwiss. Kl. Abt. I, **136**: 403-419. 1927. (Extensive bibliography of preceding work with X-rays.)
2. DE BOER, S. R. The effect of ionized air on the rate of respiration of fungi. *Annals Bot.* **44**: 989-999. 1930.
3. DE BOER, S. R. Respiration of *Phycomyces*. *Rec. Trav. Bot. Néerland.* **25**: 117-239. 1928. (Full bibliography of influence of light on respiration.)
4. DAY, T. C. The influence of light on the respiration of germinating barley and wheat. *Trans. and Proc. Bot. Soc. Edinburgh* **20**: 185-213. 1894.
5. HÉBERT, A., and A. KLING. De l'influence des radiations du radium sur les fonctions chlorophyllienne et respiratoire chez les végétaux. *Compt. Rend. Acad. Sci. [Paris]* **149**: 230-232. 1909.
6. JOHNSON, EDNA L. Effects of X-rays upon growth, development and oxidizing enzymes of *Helianthus annuus*. *Botan. Gaz.* **82**: 373-402. 1926.

7. KEILIN, D. Influence of carbon monoxide and light on indophenol oxidase of yeast cells. *Nature* **119**: 670-671. 1927.
8. LINDNER, P. Zur Wirkung ultravioletter Strahlen auf die alkoholische Gärung und auf Hefe. *Wochensh. Brauerei* **39**: 166-167. 1922. (Cites work of Fazi in *Annali di Chimico Applicata*, anno II, vol. 4.)
9. LÖWSCHIN, A. Zur Frage über den Einfluss des Lichtes auf die Atmung der niederen Pilze. *Beih. Bot. Centralbl.* **23**: 54-64. 1908.
10. LUBIMENKO, W., and A. FROLOFF-BAGREIEF. Influence de la lumière sur la fermentation du moût du raisin. *Compt. Rend. Acad. Sci. [Paris]* **154**: 226-229. 1912.
11. MASURE, M. P. The effect of ultraviolet radiation on growth and respiration of pea seeds, with notes on statistics. *Botan. Gaz.* **93**: 21-41. 1932.
12. MAXIMOW, N. A. Ueber den Einfluss des Lichtes auf die Atmung der niederen Pilze. *Centralbl. Bakt. Abt. 2*, **9**: 193-205, 261-272. 1902.
13. MIDDLETON, N. I. The effect of ionized air on the rate of respiration of barley seedlings. *Annals Bot.* **41**: 345-356. 1927.
14. POPP, H. W., and FLORENCE BROWN. A review of recent work on the effect of ultraviolet radiation upon seed plants. *Bull. Torrey Botan. Club* **60**: 161-210. 1933.
15. RANJAN, S. Recherches sur la respiration des végétaux. 1932.
16. REDFIELD, A. C., and E. M. BRIGHT. The effects of radium rays on metabolism and growth in seeds. *Jour. Gen. Physiol.* **4**: 297-301. 1922.
17. REICH, L. Experimentelles und theoretisches zur Physiologie der Strahlenwirkung. Versuche über die Beeinflussung des Wachstums und der Atmung der Pflanzen durch die Radiumstrahlen. *Studies from Plant Physiol. Lab. Charles Univ. Prague* **3**: 5-55. 1925 (= 1926). (Good bibliography.)
18. SAPOZHNIKOVA, K. V. [Respiration of wheat seed in ionized air.] [*Compt. Rend. Acad. Sci. USSR. A*] **8**: 119-124. 1928.
19. SCHNEIDER, E. Studien über die Röntgenstrahlenwirkung auf Hefe. *Strahlentherapie* **20**: 793-812. 1925.
20. SPOEHR, H. A. Variations in respiratory activity in relation to sunlight. *Botan. Gaz.* **59**: 366-386. 1915.
21. STOKLASA, J., and J. PĚNKAVA. Ueber den Chemismus des Zuckerabbaues in der lebenden Pflanzenzelle und den Einfluss der Radioaktivität auf die anaerobe Atmung der Pflanzenorganismen. *Zeitsch. Prob. Gärung, Atmung und Vitaminforsch.* **12**: 362-433. 1926.
22. WARBURG, O. Photochemisches Versuche über Atmung. *Naturwissensch.* **14**: 1181. 1926.
23. WELS, P., and MATHILDE OSANN. Die Wirkung der Röntgenstrahlen auf die Hefezelle. *Pflüger's Arch. Ges. Physiol.* **207**: 156-164. 1925.
24. WHIMSTER, K. The effect of ionized air on the assimilation and respiration of green leaves. *Annals Bot.* **41**: 357-374. 1927.

Manuscript received by the editor December, 1933.

XXXIII

GROWTH MOVEMENTS IN RELATION TO RADIATION

EARL S. JOHNSTON

Division of Radiation and Organisms, Smithsonian Institution

Light-growth response. Light intensity. Wave-length. Sensitivity. Growth substance. Generalization. References.

Growth movements in plants are effected in a manner distinctly different from amoeboid movements, locomotion of zoospores, turgor movements, etc. Growth differentials arising in the two sides of a cell or organ may be the result of either internal or external conditions, or both. Curvatures resulting in differences in growth caused by asymmetrical conditions are designated as tropisms. The present discussion is limited to tropic movements in plants and only those tropic movements which are influenced by the action of light—phototropism. Limited space does not permit either an exhaustive treatment of the subject or a complete bibliography. Other interesting references on this subject may be found in the papers mentioned in the present review. In spite of an apparent confusion in the literature (9, 33, 36, 37) there is evidence that phototropism is a special case of the more general light-growth phenomenon, and that intensity, or the energy value of radiation, as well as wave-length and duration, must be carefully considered. Then, too, the plant characteristics must be noted. Its sensitivity, frequently limited to localized regions, its response, sometimes positive, sometimes negative, and its previous history, each has a bearing on the reaction. Furthermore, there appears to be ample evidence of a substance which is directly responsible for specific growth responses.

Many of the experiments dealing with growth responses as influenced by light, have been made with sporangiophores of *Phycomyces* and coleoptiles of *Avena*, although a number of other plants have been used. Blaauw (4, 5, 6, 7) laid the foundation for much of the recent work on phototropism. Perhaps the first serious attempt to study phototropism in which quantitative measurements and interpretation of modern physics were used was made by him and published in 1909. Responses were studied in the different spectral regions of sunlight and the carbon arc. Energy values for these regions were calculated from Langley's (29) tables. Blaauw found the most effective region of the carbon spectrum for phototropic response of *Avena* seedlings to lie between 4660 and 4780 Å, while the red and yellow regions were ineffective. According to

Blaauw (5) the curvature of a plant resulting from unilateral illumination is caused by the light-growth responses of the opposite sides which are differently illuminated. The minimum amount of radiation required to produce phototropism is 20 meter-candle-seconds. It also appears that

the product of light intensity and time of exposure is a constant.¹

LIGHT-GROWTH RESPONSE

Blaauw pointed out the fact that plant organs which show phototropic curvatures also show typical light-growth responses and where no response is observed neither is there phototropic curvature. Dillewijn (17) reasoned that, "If the theory of Blaauw is correct, it must be possible to deduce the phototropic curvatures from the light-growth response of proximal and distal sides." Using *Avena sativa*, he determined the light-growth response to several different quantities of light and also to one-thirtieth of these quantities which he figured to be the light intensity received on the distal side in comparison with that received on the proximal side. This value is greater for *Avena* than for *Helianthus* and is very largely due to the light absorbed by the primary leaf. More light passes through the upper 0.5 mm., but here the light distribution is complicated by the shape of the tip.

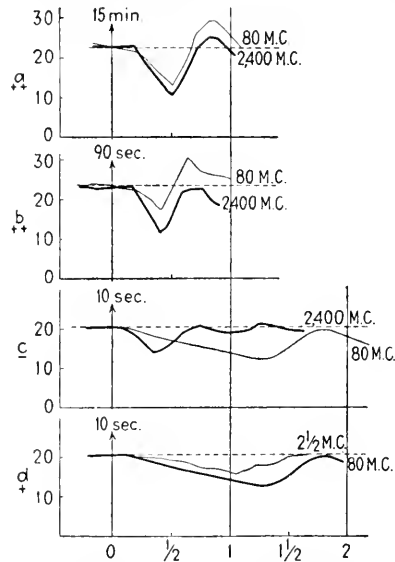

FIG. 1.—Graphs showing growth of *Avena sativa*. The abscissa represents time in hours and the ordinate rate of growth in microns per minute. The intensity of light is indicated in meter-candles. The light lines represent the growth response for $\frac{1}{30}$ the light intensity of the response represented by the heavy lines. The arrow indicates the moment of illumination with the duration marked above. The predicted phototropic response is indicated by plus and minus signs. (From Dillewijn, 17.)

but here the light distribution is complicated by the shape of the tip. He assumes the 30:1 ratio for the whole coleoptile.

Dillewijn made use of the auxanometer of Königsberger (26) for his growth measurements. The light source was above the plant and was reflected upon the seedling by three mirrors. Directly over the plant a circular cardboard disk was placed for protection against the direct rays. The results of his experiments on growth are reproduced in the four pairs of curves of Fig. 1. The abscissa represents time in hours and the ordinate the rate of growth (microns per min.). The light intensity is

¹ Parr (33) discusses briefly the data of many of the early phototropic experiments under the four general theories of intensity, ray direction, wave-length, and energy. A more extensive treatment covering the historical review of phototropism in general with its development and a critical discussion of the early theories has been published by Mast (MAST, S. O. Light and the behavior of organisms. New York, 1911).

indicated on the right in meter-candles, while the arrow indicates the time of illumination with the duration noted above in seconds.

With these curves representing the light-growth response for different given light "quantities" and for one-thirtieth of these values one can predict the phototropic curvature. Thus in *d* the growth on the proximal side (heavy line) is retarded more than on the distal side (light line) which should result in a positive bending for this weak light. With a greater quantity of light in *c* a negative bending would occur, while a further increase will again bring about positive bending, as in *b*, which gradually becomes less as the quantity is increased, as in *a*. The author concludes that the curvatures deduced from the light-growth responses of proximal and distal sides correspond with the real curvatures observed by Arisz (1). He also explains the reason why Arisz never observed negative curvatures with low light intensity over long periods of illumination. Graphs in *d* indicate "long" responses for both proximal and distal sides, thus giving a positive curvature.

Castle (10, 11) has made an extensive study of the light-sensitive system of sporangiophores of *Phycomyces* and his conclusions are in accord with those of Blaauw. Both the direct growth response and the phototropic response consist of a series of at least three similar components, namely, "(a) an exposure period during which photochemical change occurs, (b) a 'latent period' involving products directly consequent upon the photochemical action, and (c) an action time occupying a further interval before the growth acceleration appears." Castle arrives at this conclusion by noting the changes in the latent period with reference to the variable, duration of the light exposure period. He states: "The reaction time of each mode of response is constant for a particular intensity of illumination, provided that the duration of the exposure period exceeds a certain value. Below that value the reaction time increases progressively as the exposure time decreases."

Under constant conditions of growth in darkness, sporangiophores of *Phycomyces* continue at a uniform growth rate for a time. When illuminated, an increase in growth is shown; this is followed by a decrease and finally the original rate is reached. If the plant is growing at a constant rate in light and the illumination is cut off, the growth rate decreases; then it gradually returns to its former rate. This latter reaction has been called the *dark-growth response*. These sporangiophores can be "adapted" to darkness or to light of a definite intensity. A change in illumination will bring about a response, either the light-growth response or the dark-growth response, depending on the change in conditions. Castle (12) accounts for the kinetics of dark adaptation on the basis of a bimolecular reaction, which may be modified by autocatalysis. He (13) regards the light- and dark-growth responses as due to similar changes of the opposite signs in the concentration of a growth-regulating substance.

LIGHT INTENSITY

The work of numerous investigators shows, as does that of Dillewijn, previously mentioned, that light within a certain range of intensity brings about an increased growth rate while that of another range results in a diminished rate of growth. Recently Wiechulla (45) has carried out a number of experiments on the sporangiophores of *Phycomyces* using different amounts of light quantities expressed as meter-candle-second (MKS = MCS) units. These results are graphically shown in Fig. 2. The abscissa is time in minutes after illumination, and the ordinate, relative

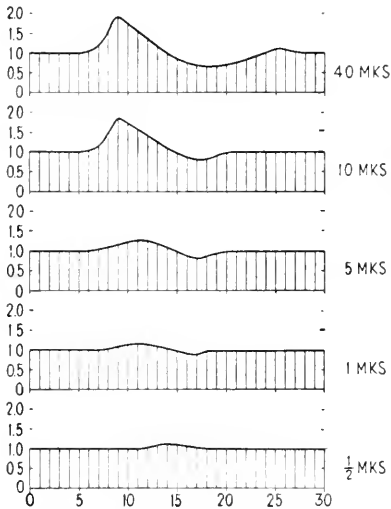

FIG. 2.—Graphs showing growth response of sporangiophores of *Phycomyces* for different light quantities indicated in meter-candle-seconds. The growth rate in darkness is taken as unity. (From Wiechulla, 45.)

Castle (15) has shown that phototropic “indifference” results from a failure of light to bring about differences in the rates of growth on the two sides of the sporangiophore. By reducing the exposure time a critical light duration period is found below which sensitive indifferent sporangiophores will show phototropic bending. He therefore concludes that phototropic bending occurs when the illumination on one side is submaximal and that indifference results when equal and maximal photochemical action takes place on both sides of the sporangiophore.

WAVE-LENGTH

In many of the early experiments on phototropism it is impossible to distinguish the wave-length effects from those of intensity. Parr (33) studied the response of *Pilobolus* to different wave-lengths and intensities of light which were carefully measured. The sources used were a Nernst

growth units, the growth rate in darkness being unity. It is interesting to note the character of these curves. For the greater units, the reaction time is short and the rate of growth rapid, which later becomes less than the rate in darkness. For the weakest light no rate lower than that in darkness is noted. Also the weaker the light the longer the reaction time.

Castle (14) states: “Alleged reversal of the phototropism of the sporangiophores of *Phycomyces* by high intensities of light does not occur if infra-red radiation is properly excluded. Phototropic ‘indifference’ alone occurs at high intensities due to equal photic action on both sides of the sporangiophore. If heat radiation is not screened out, a gradual, negative thermotropic bending takes place.”

lamp and a 200-watt nitrogen-filled tungsten Mazda lamp. The results of these quantitative studies are best summarized in her own words:

(1) *Pilobolus* responds to the light of all the regions of the visible spectrum. (2) The presentation time decreases gradually from red to violet. There is no indication of intermediate maxima or minima. (3) The presentation time does not vary in direct ratio with the measured value of the energy of the light in the different regions of the spectrum. (4) The presentation time varies in inverse ratio to the square roots of the wave frequency. (5) The product of the square root of the frequency times the presentation time, decreases with the decrease in the energy value of the spectral regions, and is an approximate constant for a given light source. (6) The spectral energy in its relation to the presentation time may be expressed approximately in the Weber-Fechner formula, if the wave frequencies be made a function of the constant. (7) The relation of the spectral energy to the presentation time may also be approximately expressed in the Tröndle formula, the wave frequencies being made a function of the constant.

Hurd (21) equalized the intensity of light coming through a series of Wratten light filters so that it measured 1800 meter-candles on reaching the young rhizoids used in this work. Only the blue (4700 to 5200 Å) and violet (4000 to 4700 Å) lights produced phototropism, negative in direction. The other lights at this intensity had no effect. With a greater intensity the green light (5200 to 5600 Å) exerted a negative phototropic effect as well as the blue and violet.

For the purpose of investigating the wave-length effects of radiation on phototropic bending of young plants Johnston (22) described a simple plant photometer which was later improved and used (24) in evaluating four spectral regions. The general procedure was to place a seedling between two different and oppositely placed lights and, after an interval, observe the growth curvature. If, for example, the seedling was exposed to blue and green lights, a distinct bending was noted toward the blue side, the lights were so adjusted as to increase the green or decrease the blue intensity. Another seedling was then used and the process repeated until a balance point was reached where the effect of one light neutralized the effect of the other. When this balance point was determined, a specially constructed thermocouple replaced the plant and the relative intensities were measured. From these experiments with oat seedlings no measurable phototropic response was found for wave-lengths longer than 6000 Å while a noticeable bending was found with the yellow filter. The threshold for wave-length influence seemed to originate somewhere between 5200 Å and 6000 Å. The effects of green and blue were progressively greater, being respectively in round numbers 1000 and 30,000 times that of yellow.

Sonne (40) determined the amount of energy of different wave-lengths necessary to bring about a minimum phototropic action in oats. About 1 cm. of the tips of young plants were placed at different distances from

the light of a monochromator for different exposure periods. For a standard of comparison the visible part of the spectrum of a Hefner lamp was used. Minimum action was obtained at 0.86×10^{-5} gm. cal./cm.²/sec. The energy was measured by a thermoelement. The results are summarized in Table 1.

TABLE 1.—DATA SHOWING PHOTOTROPIC SENSITIVITY DETERMINED FROM THE AMOUNT OF ENERGY REQUIRED TO PRODUCE A MINIMUM RESPONSE IN OATS
(From Sonne, 40)

Wave-length, Å	Absolute energy	Phototropic effect
5700	588	0.17
5460	371	0.27
4360	0.028	3572
4050	0.06	1667
3660	0.10	1000
3130	0.66	152
3020	0.96	104
2800	2.3	44
2650	32 and 15?	7
2530	19	5
2400	77	1

It will be seen from this table that the amount of energy which just causes phototropic curvature is very different for different wave-lengths. The yellow (5700 Å) is about 600 times as intense as is the white light necessary to bring about the same response, while the green (5460 Å) is approximately 400 times as intense, and the blue (4360 Å) only 0.03 as strong as the energy of his standard white light. The blue is thus approximately 10,000 times as effective phototropically as the green and 20,000 times that of yellow. The violet (4050 Å) is also very effective but only about half that of the blue.

Wiechulla (45) using the sporangiophores of *Phycomyces* found the phototropic action of light passed through Schott color filters as compared with that of white light to have the following values, in terms of the time required to give the same bending:

Orange.....	8000
Yellow.....	180
Yellow green.....	36
Blue green.....	13.6
Blue.....	4

Bergann (3) made a very careful study of the effects of monochromatic light on the growth and bending of *Avena sativa* as well as the effects produced by a change of intensity and length of exposure. Employing the method of placing the young plant between two opposite lights, he concludes that the regions other than the red and infra-red produce

corresponding growth reactions for suitable intensities. In unilateral light equal bending is shown for corresponding intensities, first positive, negative, then positive. Light curvature and light-growth reactions are parallel processes. The stronger the light-growth reaction in a given wave-length region, the greater will be the tropic response. The seedling's "choice" in the compensation experiments between two wave-length ranges is always that which corresponds to the stronger growth reaction.

Bachmann and Bergann (2) review the early work of Blaauw and correct the energy values of his data for light absorbed by CuSO_4 and water filter, also surface reflections and color filter, in order to compare his results with those obtained by Bergann. The results of Sonne and Königsberger are also corrected and compared. These data are represented graphically in Fig. 3, in which the continuous

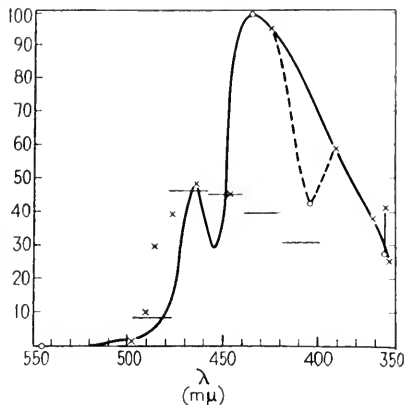

FIG. 3.—Graphs showing the sensitivity of *Avena sativa* to wave-lengths of light (continuous line) as compared with the corrected values of Blaauw (crosses), of Sonne (circles), and of Königsberger (horizontal lines). (From Bachmann and Bergann, 2.)

line is the sensitivity curve, the data from Blaauw's work are indicated as small crosses, those of Sonne as circles, and those of Königsberger as horizontal lines. The multiplier for Blaauw's data in the short wave-length region is 2.5.

From this work it is concluded that there are two maxima in the phototropic curve and that these correspond in general to the maximum light absorption regions of chromolipoids. It appears that the phototropic curvatures in the different wave-length regions follow the absorption of light by specific substances or their compounds in these same regions.

The sensitivity of the sporangio-phores of *Phycomyces* to light of different wave-lengths was investigated by Castle (16). The sporangio-phores were placed between two light sources. The intensities were adjusted until the phototropic effects of the different spectral regions were equal. At this point the efficiency of each region was taken as proportional to its relative energy content. Wratten filters were used

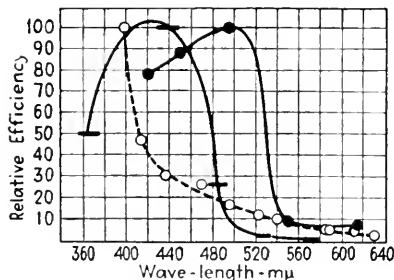

FIG. 4.—Graphs showing the relative efficiencies of different wave-lengths in their phototropic action on *Phycomyces blakesleanus* (horizontal lines), on *Phycomyces nitens* after Blaauw (solid circles), and on *Pilobolus* after Parr (open circles). (From Castle, 16.)

in conjunction with a copper chloride filter. The most sensitive region proved to be in the violet (4000 to 4300 Å). In Fig. 4 the author compares his results with those obtained by Blaauw and Parr. It is pointed out that because of the presence of "accessory" pigments in these sporangiophores care must be taken in correlating these results with those obtained from the absorption spectrum of the photosensitive substance.

The early results of Johnston, Brackett, and Hoover (24) justified a more elaborate and accurately controlled experiment wherein narrower spectral regions could be used.

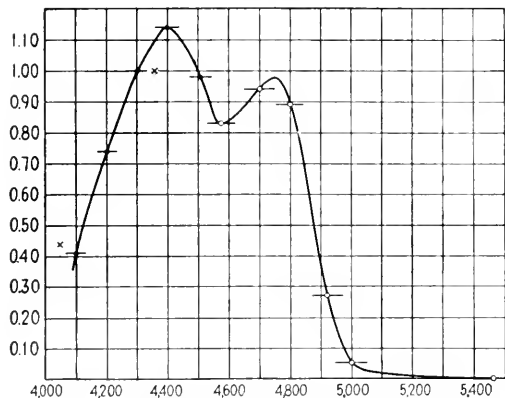

FIG. 5.—Graph showing phototropic sensitivity curve. The ordinates are relative sensitivity values, the abscissas, wave-lengths in Angströms, and the horizontal bars indicate the wave-length ranges of the balance points. Circles indicate points obtained with filters combined with the monochromator. The crosses show where mercury lines were used. (From Johnston, 23.)

light from the monochromator was passed, and through the other, light from the standard lamp. The standard light used was a 200-watt, 50-volt projection Mazda lamp with the filaments in a plane. This light was passed through a Corning line filter (No. 6.0), a heat-absorbing glass, and a water cell. Its radiation intensity was $0.37 \mu\text{w}/\text{cm}^2$ at a distance of 25 cm. The general method of procedure was similar to that used with the earlier type of plant photometer.

The data from this more accurately controlled experiment are presented in the table shown on page 1081, and shown graphically in Fig. 5.

The phototropic sensitivity curve rises sharply from 4100 Å to a maximum of 4400 Å. It then drops off to a minimum at about 4575 Å and again rises to a secondary maximum in the region 4700 to 4800 Å. The fall is very rapid from this point to 5000 Å, thence it tapers off very gradually to a threshold on the long-wave-length side at about 5461 Å.

For this purpose Johnston (23) used a specially constructed monochromator and exercised considerable care to eliminate scattered light and to keep the conditions surrounding the coleoptile symmetrical, with the exception of the wave-length region being investigated. A double-walled glass cylinder with water between the walls slowly rotated about the axis of the coleoptile. The entire cylinder was enclosed in a light-proof box which contained two oppositely placed side windows. Through one,

TABLE 2.—DATA SHOWING THE PHOTOTROPIC EFFECTIVENESS OF RESTRICTED REGIONS OF THE VISIBLE SPECTRUM
That for the Hg line 4358 Å is taken as unity. (From Johnston, 23)

Wave-length range, Å	Filter used with monochromator	Light intensity ratio (monochromator/standard)	Relative phototropic effectiveness
4945-5055	SG	9.37	0.05
4873-4970	NC	1.78	0.27
4760-4840	HRN	0.54	0.89
4650-4750	SG	0.51	0.94
4530-4620	SG	0.58	0.83
4470-4545	0.49	0.98
4360-4440	0.42	1.14
4270-4335	0.48	1.00
4170-4230	0.65	0.74
4072-4125	1.18	0.41
Hg 4358	0.48	1.00
Hg 4047	1.08	0.44

NOTE.—SG, Sextant green (1.94 mm.); NC, Noviol "C" (4.15 mm.); HRN, heat-resistant Noviol (3.04 mm.).

SENSITIVITY

In much of the work with coleoptiles the entire length of the organ was exposed to light. Such experiments are not strictly comparable with those in which only the tips are illuminated. Lange (28) has shown that the first 50 μ of the tip is the most sensitive. Toward the base the sensitivity decreases. He reports that the first millimeter zone is 160 times as sensitive as the second millimeter zone and 1800 times that of the third. Lange's idea that only the tip is the region of light perception is not in agreement with the work of Went (42) who determined the difference in the light-growth response of the tip (first 2.5 mm.) and the base (6 mm. from tip) of coleoptiles illuminated on three sides. Went is of the opinion that there are two distinct growth responses, the *tip response* and the *base response*.

These differences are perhaps best seen in Fig. 6 (his Graphs 3 to 5). Their interpretation should be of interest in connection with Dillewijn's experiments and other work where positive and negative curvatures are obtained with different light intensities.

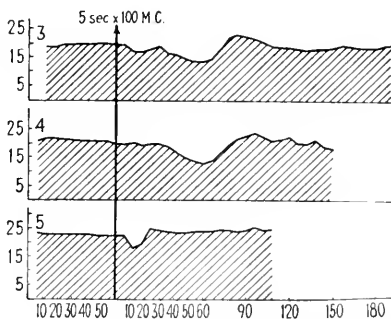

FIG. 6.—Graphs showing light-growth response of *Arca*. The ordinate represents growth in microns per minute, the abscissa time in minutes, the arrow the moment of illumination. Graph 3, illumination of entire coleoptile (12 mm. long); Graph 4, illumination of the tip (1.25 mm.); Graph 5, illumination of base (9 mm.) while the top (3 mm.) is kept in darkness. (From Went, 42.)

Went's data indicate two reactions, and in this respect they agree with what Sierp (38) mentioned earlier. In Graph 3 the entire coleoptile is illuminated, in Graph 4 only 1.25 mm. of the tip, and in Graph 5 only 9 mm. of the base, while the top 3 mm. is kept in darkness. The abscissa represents the time in minutes and the ordinate the growth in microns per min. The arrow is the point of illumination for 5 sec. by 100 meter-candles. In Graphs 4 and 5 it will be seen that the first effect of light is a retardation followed by an acceleration in the growth rate. When only the base is illuminated (Graph 5) the minimum occurs after 16 min. When the illumination is confined to the top (Graph 4) the minimum occurs after approximately 60 min. When the entire seedling is illuminated (Graph 3) the two separate light-growth responses are distinctly seen. The position of the minimum of these curves depends on temperature, a somewhat lower temperature retards the time of minimum growth rate. Also the duration of the illumination enters as a factor. Went points out that the responses of Königsberger (27) with continuous illumination must be considered a base response.

Arisz's work shows that the first positive curvature occurs when the tip of the coleoptile is illuminated by light less than 4000 mcs. From these facts and those furnished by Dillewijn, Went concludes that, "The first positive curvature results from the different tip responses of the proximal and the distal sides of the coleoptile" and that, "The second positive curvature is the consequence of the base responses of the proximal and the distal sides of the coleoptile," which appears after more illumination. These suppositions are in agreement with Blaauw's theory. Moreover, it is possible to account for the negative curvatures by a combination of the tip and base responses.

In a later paper Dillewijn (18) discusses experiments in which illumination was limited to three zones of coleoptiles: Zone 0, from the tip down to 2 mm.; Zone II, from the 2-mm. to the 7-mm. point; and Zone VII, from the 7-mm. to the 9-mm. point. It was found that the top zone was by far the most important, especially from 0 to 0.5 mm. The light quantities used were 800, 8000, 80,000, and 800,000 mcs, at 20°C. and 80 per cent humidity. A layer of water absorbed the heat rays.

"Between 0 and 800 mcs the retardation becomes continually stronger by increasing quantities of light, that between 800 and 8000 mcs it reaches a maximum and then diminishes and entirely disappears at 8000 mcs. By still increasing the light an acceleration sets in, which at 80,000 mcs is fairly considerable, and with still more light also diminishes again so that at 800,000 mcs, disregarding a transitory retardation and acceleration, an indifferent stage is again reached. The same behavior was found for the uppermost top zone of 0.5 mm., with this difference that both retardation and acceleration are somewhat smaller than in illuminating Zone 0. This means that the top reactions take

place almost entirely in the extreme 0.5 mm. of the top and the next 1.5 mm. is only very little sensitive to these top reactions. . . . All basal zones lack the property of giving top reactions with any of the light-quantities used." But the author found that all the zones give short reactions with large light quantities (about 8000 mcs) and that the top zone gives only long reactions.

From the application which Dillewijn makes of the growth reactions to phototropism it appears to him "that the first positive curvature is caused by unequal growth-retardations at the front and back, while the second positive curvature is caused by unequal growth accelerations at the front and back. Negative responses may be caused in various ways. The front may present a retardation or an indifferent reaction, as well as an acceleration, while the back may also present this reaction, provided that the growth rate is there smaller than at the front." He therefore claims that the theories of Paál (32) and Boysen-Jensen (8) are not at variance. Paál's conception that light influences the formation of growth-regulating substances in the tops, which are continually produced in darkness, holds good for the first positive curvature, while that of Boysen-Jensen, that a positive curvature is caused by growth acceleration on the shaded sides, holds good for the second positive curvature.

Dillewijn concludes that, "Phototropic curvature with large light quantities consists of two different components, namely of passing oscillations, caused by reactions in all parts of the coleoptile, and of the phototropic curvature proper, caused by the long reaction which occurs in the top only and from there proceeds downward."

GROWTH SUBSTANCE

Dolk (19) carried out a number of experiments which showed the immediate connection between the production of a growth substance and the transmission of the phototropic stimulus. By cutting off the sensitive tips of coleoptiles of *Avena sativa* he found that the upper portion of the decapitated coleoptile became sensitive in 150 min. to a definite amount of light, while the corresponding zones of the intact coleoptiles showed no such growth accelerations.

Studies on the appearance of new physiological tips of decapitated coleoptiles reported by Söding (39) and by Dolk (19) were extended by Li (30) with special attention to the influence of environmental conditions on the formation of growth-promoting substances and the effect of the length of tip removed. In these experiments he considered the average number of minutes between decapitation and the minimum growth rate a measure of the ability to regenerate these growth substances. For the temperature range studied (10° to 35°C.) the time required for the appearance of a new physiological tip varied considerably

(391 to 75 min.), being shorter for the higher temperatures. Light exerted no influence. The time required to develop a new tip also varied with the length cut off, being shorter for a short section cut off. Contrary to Dolk's claim that the growth of a regenerated tip never reaches the value of that before decapitation, Li found that with the removal of only 1 to 2 mm., a growth substance is produced that equals that of the original. Dolk cut off 4 mm. in his experiments.

The work of earlier investigators likewise indicated that by removing the tip, the properties of the tip are assumed by the uppermost zone. Paál (32) assumed a growth regulator in the coleoptile of *Avena*. When this substance diffuses from the tip into the growing region, growth is accelerated. He also was of the opinion that light either prevents the formation of this substance, destroys it, or impedes its diffusion.

Went (43) has carried out a number of most interesting experiments which have given much information as to the formation, character, and effect of the growth-accelerating substance produced in the tips of coleoptiles of *Avena*. He placed a number of tips cut from coleoptiles on a thin sheet of gelatin with the cut surfaces next to the gelatin. After an hour these tips were removed and the gelatin cut into small blocks which were then placed on one side of decapitated coleoptiles. In 3 hr. these decapitated coleoptiles showed very marked bending (negative) with the blocks on the convex sides. Control blocks not previously treated with the growth substance from tips produced either no bending, or a very slight positive curvature. Likewise, gelatin on which sections below the tip had stood gave no curvatures.

Went raises the question: "What influence has light on the formation of growth regulators?" By illuminating the coleoptiles with different quantities of light from 0 to 1,000,000 mcs and impregnating gelatin with substances from these tips and studying the curvatures produced on decapitated coleoptiles, he shows that a less amount of growth substance diffuses into the gelatin from the tips irradiated with 1000 mcs than from those irradiated with 100,000 mcs. He also shows the possibility of imitating phototropic bending. Stated in his own words, "To do this I first placed, as in all former experiments, on one side of the stump gelatin, treated with tips to which an illumination of, *e.g.*, 100,000 mcs had been applied. Then on the other side a gelatin block was placed, on which tips had stood that had been illuminated with ten times less light. In this way a gelatin system was placed on the stump which, according to Blaauw's theory, as nearly as possible approached the unilaterally illuminated tip. The plantlets indeed bent themselves in perfect accordance with the figures obtained by Arisz. With a difference of 1000 versus 0 mcs a positive curvature (in 7 out of 9 plants, 2 remained straight) occurred, reckoned toward the 1000 mcs. With 10,000 versus 1000 mcs the curvature was negative. With 100,000 versus 10,000

mcs I found a positive curvature again, *i.e.*, toward the 100,000 mcs." It appears that the retardation in growth obtained by Dillewijn with an illumination of 800 mcs and the acceleration with 80,000 mcs was the result of a smaller and larger formation of growth-promoting substances, respectively.

Went concludes that, "The influence of light on a coleoptile of *Avena* therefore appears in this investigation as in the former to be twofold: in the first place it has an effect on the formation of growth regulators in the tip, and secondly it temporarily diminishes the transport rate of the growth regulators."

The influence of these growth-promoting substances was further studied by Uijldert (41). The removal of the flower buds of *Bellis perennis* greatly retards the growth of the flower stalks. One experiment will serve to illustrate the effect of the growth substance from *Avena* on these flower stalks. In each of the following cases six flower buds were cut off and the growth of the stalks noted after 24 hr.

- A. Flower buds replaced: growth, 1.43 mm.
- B. Agar with 2000 tip-minute growth substance per flower stalk (one "tip-minute" is the amount of growth-promoting substances which diffuse out of the coleoptile tip into an agar disk in 1 min. A value of 600 tip-minutes may mean, therefore, the amount diffusing out of 6 tips in 100 min. or out of 12 tips in 50 min.): growth, 1.93 mm.
- C. Pure agar without growth substance: growth, 0.40 mm.
- D. Control in which buds were simply cut off: growth, 0.63 mm.

From the results found by Uijldert and later work it appears that the growth-promoting substances of one plant may influence the growth of another type of plant. These substances occur in such minute quantities that they are more or less comparable to animal hormones. They occur in the coleoptiles of grasses, in various fungi, yeasts, and bacteria.

Recently Dolk and Thimann (20) have attempted to determine the chemical nature of these substances. Because of the difficulty of extracting them from the tips of coleoptiles, they secured them from the fungus *Rhizopus suinus*. The activity of their material was tested on coleoptiles of *Avena*, as described by Went (44). Briefly, the method consists of impregnating small blocks of agar and placing them on the sides of decapitated coleoptiles and noting the curvatures after a given time interval. These authors state that, "In order to be able to bring all the data on to a quantitative basis, some kind of a unit system had to be introduced. As *unit* was chosen that quantity of growth substance which has to be present in 1 cc. of solution to give, after mixing with 1 cc. of agar, an angle of 1 deg. The total number of units per cubic centimeter of solution is then found by multiplying the angle measured by the dilution in which the test was carried out. In the experiments below, the first figure gives always the dilution, the second the angle actually measured. The actual amount of material in the block applied to the

plant is only one two-hundredth of that which is present in 1 cc., and this quantity is termed a plant unit. The units defined above have only an arbitrary value, since their application is limited to measurements in which the procedure described above is rigidly adhered to. The same dependence upon the conditions of the test applies to the biological assay of all animal hormones. The variety of oat used, the culture conditions, the size of the agar blocks, and the time relations between the various manipulations will all exert a considerable influence upon the final result."

Several methods for purifying this growth-promoting substance were examined and one obtained which gives extracts of fairly constant purity. Traces of peroxide, present in freshly distilled ether, are sufficient to destroy some 20 per cent of the activity. From their investigations it is shown that the growth substance is an acid with a dissociation constant of 1.8×10^{-5} . Some of the chemical properties are given as well as its stability to acids and alkalies.

A few months later Kögl (25) reported the results of his chemical studies of the growth substance ("auxin") which Went found in the tips of oat seedlings and which is similar in its reaction on decapitated seedlings to the material found by Nielsen (31) in mushrooms. A similarly acting product was also extracted from "mash" obtained in the process of making alcohol by fermentation of molasses. Kögl attempted to extract the pure growth substance from 100,000 tips of *Avena* but found human urine a much better source of supply. He realizes that it is too soon to state that the active substances from these different sources are identical, although they bring about similar responses in the test plants. During his extraction and purification processes he tested the material on sprouts, making use of the *Avena* unit (AE), *i.e.*, the amount of substance which at a temperature of 22° to 23°C. and a humidity of 92 per cent will bring about a curvature of about 10 deg.

The auxin behaves as a monobasic acid. After recrystallizing from alcoholigroin, it was found to have a melting point of 196°C. and an activity of about 50,000,000 AE/gm. The auxin lacton melts at 170°C. and has an activity of about 30,000,000 AE/gm. The molecular weight by the Rast method is 338 and by titration 340. Microanalysis gives good agreement with the formula $C_{18}H_{32}O_5$. Urine obtained about 3 hr. after the main meal gives a substance with maximum activity. Otherwise no difference was found as to sex or age.

Cubes of skin and muscle tissue were placed on the sides of decapitated coleoptiles instead of the small blocks of agar in the AE test, but only negative results were obtained. Cubes cut from cancer tumors on mice were also negative.

GENERALIZATION

Priestley (36) in a review of the subject of phototropic growth curvatures has attempted to show that the suggestion of de Candolle still

supplies an adequate explanation of this phenomenon. The view that phototropic curvatures result from the direct action of an external agent upon the growing region is held preferable to the interpretation of the phenomenon in terms of a stimulus, or "releasing mechanism," as held by Pfeffer. Blaauw's results indicate a close quantitative relationship between the unilateral light causing phototropism and the response itself. Priestley points out "that if the duration of exposure is sufficiently long, any intensity of light may produce a phototropic response. The product of minimal time of exposure necessary into intensity of light always gave the same value of 20 meter-candle-seconds, below which light quantity no response *can be observed*. Thus there is no absolute threshold value of duration of exposure, or of intensity of light."

Priestley emphasizes the point that etiolated shoots are far more sensitive to light than normal ones and that this distinction must be fully recognized in the interpretation of phototropism from his point of view. Where phototropic bending occurs in normal light-grown shoots, light influences the nutrition and extension of the cells at the growing point. This mechanism is quite different from that occurring in etiolated shoots. Here Priestley brings to bear his earlier observations (34, 35) in support of Blaauw's views. In etiolated shoots "fatty and protein substances will be released from complex forms of chemical combinations; the proteins will disappear from the walls and the fatty substances migrate mainly to the cuticle. The walls of the cells of the meristem, and of the tissues which intervene between the meristem and the vascular supply, are thus partly freed from protein and fat and now consist mainly of carbohydrates. Along the walls the sap from the vascular supply can now percolate more freely and water-soluble solutions in this sap find readier access to the superficial cells of the meristem, which are farthest away from the vascular supply, and which before were only growing slowly. Increased superficial growth now ensues. Growth as a whole may be as active as ever on the more brightly lit side of the etiolated shoot, *but it is differently distributed*. More cells are added to the surface of stem and leaf and less proportionately to the inner layers of the shoot axis. The result is, therefore, in the aggregate, a retardation of growth *in length* on the illuminated side and a positive phototropic curvature."

In a later paper Priestley (37) reexamines the data found in the literature on phototropism of etiolated coleoptiles and attempts to use this in support of his viewpoint rather than another for which they were intended. It is pointed out that practically all coleoptiles employed in phototropic experiments are at least 0.5 cm. long. At this stage the meristematic tissue has disappeared, so that subsequent growth takes place through vacuolation and extension in length of already existing cells and not from cell formation. Cell extension is more rapid in light than in darkness, but their final length is less. Priestley makes use of the fact that growth

depends on cell turgidity as the basis of his explanation of the results obtained in numerous decapitation experiments. A portion of his discussion is perhaps best summarized in his own words.

"The frequent occurrence of apical guttation is recalled, it is shown that the localization of the apical hydathode explains the direction of the usual autonomous curvature of the coleoptile. The permeability of the coleoptile tissues are increased by light, and therefore light falling on the apex increases the apical guttation. Lateral light falling on the apex therefore increases the rate of flow from the vein nearer the light and thus produces a phototropic curvature. When the apex is removed, guttation is very free and growth much reduced until the cut surface is blocked. If the apex is replaced immediately, the guttation is reduced and growth is greater. If the apex is replaced on the side of the stump only, this side only is blocked and curvature results. From the same standpoint the different curvatures produced by the asymmetric replacement of an apex or a ring of coleoptile tissue are explicable. If the replaced apex is laterally illuminated the block is less complete on this side of the stump and positive tropic curvature results. The various facts at present elucidated by investigators as due to growth regulation by substances diffusing from the apex, are passed in review from this new standpoint, and appear to be consistent with it. On the other hand, the fact of the upward flow of guttation, reported by nearly all experimenters with decapitated coleoptiles on which tips are replaced, is not easily reconciled with the idea of the downward diffusion of growth-regulating substances. It is then shown that an interpretation of the phenomena of phototropic curvature in the coleoptile which is consistent with the 'light-growth' hypothesis of Blaauw can be applied with less difficulties and fewer inconsistencies than any interpretation yet attempted on the lines of stimulus and response."

Although Priestley's point of view is very interesting and stimulating, there are several points which it seemingly does not fully explain; for example, as mentioned by him, the succession of positive and negative curvatures is one problem. The more recent work with growth-accelerating substances presents other difficult problems not easily answered. From the careful work of Went and his associates there can be but little doubt that the growth-accelerating substances, though small in actual quantity, play an important role in phototropic responses. The rapid advances made in the accumulation of quantitative data during the past five years lends hope that in the near future important relationships will be obtained from the existing mass of what now appears at times to be merely conflicting data. Furthermore, much of this information promises to have a direct bearing on the relationship of certain cell products and life processes to radiation.

REFERENCES

1. ARISZ, W. H. Untersuchungen über den Phototropismus. *Rec. Trav. Bot. Néerl.* **12**: 44-216. 1915.
2. BACHMANN, FR., and FR. BERGMANN. Über die Wertigkeit von Strahlen verschiedener Wellenlänge für die phototropische Reizung von *Avena sativa*. *Planta, Arch. Wiss. Bot.* **10**: 744-755. 1930.
3. BERGANN, FRIEDRICH. Untersuchungen über Lichtwachstum, Lichtkrümmung und Lichtabfall bei *Avena sativa* mit Hilfe monochromatischen Lichtes. *Planta, Arch. Wiss. Bot.* **10**: 666-743. 1930.
4. BLAAUW, A. H. Die Perzeption des Lichtes. *Rec. Trav. Bot. Néerl.* **5**: 209-372. 1909.
5. BLAAUW, A. H. Licht und Wachstum. I. *Zeitsch. Bot.* **6**: 641-703. 1914.
6. BLAAUW, A. H. Licht und Wachstum. II. *Zeitsch. Bot.* **7**: 465-532. 1915.
7. BLAAUW, A. H. Licht und Wachstum. III. Die Erklärung des Phototropismus. *Mededeel. Landbouwhoogeschool, Wageningen* **15**: 89-204. 1919.
8. BOYSEN-JENSEN, P., and NIELS NIELSEN. Studien über die hormonalen Beziehungen zwischen Spitze und Basis der *Avenacoleoptile*. *Planta, Arch. Wiss. Bot.* **1**: 321-331. 1925.
9. BRAUNER, LEO. Die Blaauwsehe Theorie des Phototropismus. *Ergeb. Biol.* **2**: 95-115. 1927.
10. CASTLE, E. S. The light-sensitive system as the basis of the photic responses of *Phycomyces*. *Proc. Nation. Acad. Sci.* **16**: 1-6. 1930.
11. CASTLE, E. S. Phototropism and the light-sensitive system of *Phycomyces*. *Jour. Gen. Physiol.* **13**: 421-435. 1930.
12. CASTLE, E. S. Dark adaptation and the light-growth response of *Phycomyces*. *Jour. Gen. Physiol.* **12**: 391-400. 1929.
13. CASTLE, E. S. Dark adaptation and the dark growth response of *Phycomyces*. *Jour. Gen. Physiol.* **16**: 75-88. 1932.
14. CASTLE, E. S. On "Reversal" of phototropism in *Phycomyces*. *Jour. Gen. Physiol.* **15**: 487-489. 1932.
15. CASTLE, E. S. Phototropic "Indifference" and the light-sensitive system of *Phycomyces*. *Botan. Gaz.* **91**: 206-212. 1931.
16. CASTLE, E. S. The phototropic sensitivity of *Phycomyces* as related to wavelength. *Jour. Gen. Physiol.* **14**: 701-711. 1931.
17. DILLEWIJN, C. VAN. Onderzoekingen omtrent het verband tusschen fotogroei-reactie en phototropische kromming bij kiemplantjes van *Avena sativa*. *Kais. Akad. Wetenschap. Amsterdam Verslag Gewone Vergader. Afd. Natuurk.* **34**: 770-775. 1925. (See also—The connection between light-growth response and phototropical curvature of seedlings of *Avena sativa*. *Kais. Akad. Wetenschap. Amsterdam Proc. Sect. Sci.* **28**: 775-780. 1925.)
18. DILLEWIJN, C. VAN. De lichtgroei-reacties van verschillende zones bij het coleoptiel van *Avena sativa*. *Kais. Akad. Wetenschap. Amsterdam Verslag Gewone Vergader. Afd. Natuurk.* **35**: 600-607. 1926. (See also—On the light-growth-reactions in different zones of the coleoptile of *Avena sativa*. *Kais. Akad. Wetenschap. Amsterdam Proc. Sect. Sci.* **30**: 2-9. 1927.)
19. DOLK, H. E. De invloed der decapitatie van kiemplantjes van *Avena sativa* op hun gevoeligheid voor licht en zwaartekracht. *Kais. Akad. Wetenschap. Amsterdam Verslag Gewone Vergader. Afd. Natuurk.* **35**: 595-599. 1926. (See also—Concerning the sensibility of decapitated coleoptiles of *Avena sativa* for light and gravity. *Kais. Akad. Wetenschap. Amsterdam Proc. Sect. Sci.* **29**: 1113-1117. 1926.)

20. DOLK, H. E., and K. V. THIMANN. Studies on the growth hormone of plants. I. Proc. Nation. Acad. Sci. **18**: 30-46. 1932.
21. HURD, ANNIE MAY. Some orienting effects of monochromatic lights of equal intensities on *Fucus* spores and rhizoids. Proc. Nation. Acad. Sci. **5**: 201-206. 1919.
22. JOHNSTON, EARL S. A plant photometer. Plant Physiol. **1**: 89-90. 1926.
23. JOHNSTON, EARL S. Phototropic sensitivity in relation to wave length. Smithsonian Misc. Coll. **92** (No. 11): 1-17. 1934.
24. JOHNSTON, EARL S., F. S. BRACKETT, and W. H. HOOVER. Relation of phototropism to the wave-length of light. Plant Physiol. **6**: 307-313. 1931.
25. KÖGL, F. Ueber die Chemie des Auxins eines pflanzlichen Wuchsstoffes. Chemisch Weekblad. **29**: 317-318. 1932.
26. KÖNINGSBERGER, V. J. Tropismus und Wachstum. Rec. Trav. Bot. Néerl. **19**: 1-136. 1922.
27. KÖNINGSBERGER, V. J. Lichtintensität und Lichtempfindlichkeit. Rec. Trav. Bot. Néerl. **20**: 257-312. 1923.
28. LANGE, SIEGFRIED. Die Verteilung der Lichtempfindlichkeit in der Spitze der Haferkoleoptile. Jahrb. Wiss. Bot. **67**: 1-51. 1927.
29. LANGLEY, S. P. Researches on solar heat and its absorption by the earth's atmosphere. U. S. War Dept. Professional Papers, Signal Service No. 15, 242 p. Washington, 1884.
30. LI, TSI-TUNG. The appearance of the new physiological tip of the decapitated coleoptiles of *Avena sativa*. Kais. Akad. Wetenschap. Amsterdam Proc. Sect. Sci. **33**: 1201-1205. 1930.
31. NIELSEN, N. Untersuchungen über einen neuen wachstumsregulierenden Stoff Rhizopkin. Jahrb. Wiss. Bot. **73**: 125-191. 1930.
32. PAÁL, A. Über phototropische Reizleitung. Jahrb. Wiss. Bot. **58**: 406-473. 1918.
33. PARR, ROSALIE. The response of *Pilobolus* to light. Ann. Bot. **32**: 177-205. 1918.
34. PRIESTLEY, J. H. Light and growth. I. The effect of brief light exposure upon etiolated plants. New Phytol. **24**: 271-283. 1925.
35. PRIESTLEY, J. H. Light and growth. II. On the anatomy of etiolated plants. New Phytol. **25**: 145-170. 1926.
36. PRIESTLEY, J. H. Light and growth. III. An interpretation of phototropic growth curvatures. New Phytol. **25**: 213-226. 1926.
37. PRIESTLEY, J. H. Light and growth. IV. An examination of the phototropic mechanism concerned in the curvature of coleoptiles of the Gramineae. New Phytol. **26**: 227-247. 1926.
38. SIERP, H. Untersuchungen über die durch Licht und Dunkelheit hervorgerufenen Wachstumsreaktionen bei der Koleoptile von *Avena sativa* und ihr Zusammenhang mit den phototropischen Krümmungen. Zeitsch. Bot. **13**: 113-172. 1921.
39. SÖDING, HANS. Zur Kenntnis der Wuchshormone in der Haferkoleoptile. Jahrb. Wiss. Bot. **64**: 587-603. 1925.
40. SONNE, CARL. Weitere Mitteilungen über die Abhängigkeit der lichtbiologischen Reaktionen von der Wellenlänge des Lichts. Strahlentherapie **31**: 778-785. 1928-29.
41. UJLDERT, INA E. De invloed van groeistoffen uit coleoptilen van *Avena* op den groei van gedecapiteerde bloemstengels van *Bellis perennis*. Kais. Akad. Wetenschap. Amsterdam Verslag Gewone Vergader. Afd. Natuurk. **36**: 1132-1134. 1927. (See also—The influence of growth-promoting substances on decapitated flower-stalks of *Bellis perennia*. Kais. Akad. Wetenschap. Amsterdam Proc. Sect. Sci. **31**: 59-61. 1928.)

42. WENT, F. W. Over het verschil in gevoeligheid van top en basis der coleoptielen van *Avena* voor licht. *Kais. Akad. Wetenschap. Amsterdam Verslag Gewone Vergader. Afd. Natuurk.* **34**: 1021-1027. 1925. (See also—Concerning the difference in sensibility of the tip and base of *Avena* to light. *Kais. Akad. Wetenschap. Amsterdam Proc. Sect. Sci.* **29**: 185-191. 1926.)
43. WENT, F. W. On growth-accelerating substances in the coleoptile of *Avena sativa*. *Kais. Akad. Wetenschap. Amsterdam Proc. Sect. Sci.* **30**: 10-19. 1927.
44. WENT, F. W. Wuchsstoff und Wachstum. *Rec. Trav. Bot. Néerl.* **25**: 1-116. 1928.
45. WIECHULLA, OTTO. Beiträge zur Kenntnis der Lichtwachstumsreaktion von *Phycomyces*. *Beitr. Biol. Pflanzen* **19**: 371-419. 1932.

Manuscript received by the editor November, 1934.

CHLOROPHYLL AND CHLOROPHYLL DEVELOPMENT IN RELATION TO RADIATION

O. L. INMAN, PAUL ROTHEMUND, AND C. F. KETTERING

Antioch College, Yellow Springs, Ohio

Condition of chlorophyll in the chloroplast. Chlorophyll development in relation to radiation. Effect of radiation on extracted chlorophyll. Behavior of chlorophyll under the influence of ultra-violet radiation. Influence of factors other than radiation on chlorophyll formation. Yellow pigments associated with chlorophyll. References.

CONDITION OF CHLOROPHYLL IN THE CHLOROPLAST

A good review of the literature on the origin of plastids in the plant and on the association of the various pigments in the same plastid was given by Zimmermann (89). Pfeffer (54) called attention to the fact that since the plastid is an organized part of the living cell, its functioning must at all times be considered with this in mind. Willstätter and Stoll (86, pages 54-55) believed chlorophyll to be held in the chloroplast in the colloidal state. The action of solvents upon the leaf material, and the nature of the absorption spectrum of the living leaf as compared with that of extracted chlorophyll which had been made colloidal, led to this opinion.

Stern (72) concluded that only molecularly dispersed chlorophyll is fluorescent and, since chlorophyll in the chloroplast, as in the alga *Chlorella*, is fluorescent, it is therefore molecularly dispersed through the plastid and may be in a viscous solvent (lipoid) which is itself colloiddally dispersed. Tswett (78a) demonstrated that chlorophyll fluoresces in the living plant and he found fluorescence in *Spirogyra* at $\lambda 6850$ to 6700 \AA and $\lambda 6600$ to 6500 \AA , and in *Oscillatoria* at $\lambda 6700$ to 6300 \AA . Lloyd (37) confirmed these results of Tswett. According to Noack (46) chlorophyll in the living leaf is present in a state of adsorption in a monomolecular layer on the protein of the chloroplasts. Hilpert, Hofmeier, and Wolter (27) believe that the chlorophyll in the leaf is related in some way both to the carotinoids and to protein, and that it is certainly not in solution in the lipoid phase. It is obvious that there still remains room for further clarification as to the physicochemical state of the chlorophyll in the chromatophore.

CHLOROPHYLL DEVELOPMENT IN RELATION TO RADIATION

In general, plants do not become green unless exposed to visible radiation, but Artari (1) showed that some one-celled algae turn green

in darkness if given the proper nutrients, and Sachs too, demonstrated that in seedlings of *Pinus sylvestris* and *Picea* sp. the cotyledons are green in darkness and form functionally active chloroplasts. This research was enlarged upon by Burgerstein (5), taking into consideration the effect of temperature on the greening in complete darkness. Seedlings of most of the Coniferae and of the genus *Ephedra* turn green in the absence of light, the most favorable temperature being 15° to 25°C. Lubimenko found, however, that in the greening of coniferous seedlings in the dark less chlorophyll is produced. It was Pfeffer who first called attention to the fact that the formation of chlorophyll may not necessarily be connected with the presence of light, and its nonformation in darkness in most plants may be due to disturbances of nutrition or pathological conditions.

Sachs (60) stated that light of moderate intensity is best suited to the formation of chlorophyll in the plant and Famintzin's (18) experiments led to the same conclusion. In a rather long series of experiments on sunflowers, tomatoes, tobacco, *Geum*, and other plants, Shirley (67) found that chlorophyll concentration increased with decreasing light intensity until the intensity was so low that it hazarded survival. Further decrease in light intensity caused a decrease in chlorophyll concentration. Wiesner (83) believed that this reduced accumulation of chlorophyll in strong light was due to the fact that the decomposition and formation of chlorophyll occurred together, and while the strong light favored rapid formation, it also hastened decomposition.

Wiesner also investigated qualitatively the effect of wave-length of light on chlorophyll formation and found that in weak light plants become green more rapidly under the influence of the red, orange, yellow, and a certain region of the green, while in strong light they green more rapidly in the blue rays. Dangeard (7) found that in the seedlings of *Lepidium* visible greening occurs only in wave-lengths longer than 5100 Å. Blanched leaves of spinach turn green between 6800 and 4400 Å to a varying degree, with a maximum between 6800 and 6560 Å and a weaker maximum in the blue-violet. Sayre (63) studied this question more thoroughly and found that wave-lengths longer than 6800 Å are not effective in the formation of chlorophyll in seedlings of corn, wheat, oats, barley, beans, sunflowers, and radishes. All other regions of the remaining visible and ultra-violet spectrum (to 3000 Å) are effective, provided the energy value is sufficient. For approximately equal energy values in these regions, the red rays are more effective than the green, and the green more effective than the blue. The question of the comparative effectiveness of the various wave-lengths of radiation is complicated by the fact that even if equal energy values for each wave-length of light are used, we are still unable to determine how much of any particular wave-length is absorbed and made use of by the reacting compounds which form chlorophyll in the living plant.

Just how light may function in chlorophyll formation is a problem of great complexity. Preisser (56) investigated the formation of chlorophyll in etiolated plants and believed the leaf green to be formed by the oxidation of a colorless compound. He describes his results as follows: "Green leaves were ground in a porcelain mortar. The green fluid obtained by this process was treated with a little lead hydroxide after the filtration. This completely precipitated the green matter. The lead compound was decomposed with hydrogen sulfide. The filtered liquid was colorless. I put it with a little oxygen gas under a mercury receiver. After several days a part of the gas was absorbed, the liquid had become green and flakes of still darker green had deposited. The absorption took place especially under the influence of sunlight." Sachs (61) discusses this question of chlorophyll formation under 11 headings, the most pertinent ones to our discussion being:

"Leaf green is formed from a substance which is still colorless and which requires only a very small change in order to become green."

"The formation of this chromogen or leucophyll takes place in most cases simultaneously with the decomposition of the plasma in the grains, frequently, also, earlier."

"The leucophyll passes over into chlorophyll by the action of oxygen in the nascent state or generally by means of very active oxygen, probably because a part of the hydrogen is thereby taken away from the leucophyll."

"In nearly all cases this oxidation takes place if, under the influence of sunlight, oxygen from other compounds becomes free within the cells."

"The oxidation of the leucophyll to chlorophyll can also take place without the direct influence of light when very active oxygen diffuses to unlighted parts (chlorophyll in the wood) or when certain substances in the cells (fats and ethereal oils) have the property of ozonizing the oxygen (chlorophyll in the embryo of the pine)."

Monteverde (44) has studied the origin of chlorophyll in the etiolated plant when exposed to light. He found in etiolated leaves a substance which, under the influence of light, is replaced by chlorophyll; and he called this "protochlorophyll." This substance varies in its absorption spectrum and other properties from Timiriacheff's (77) protochlorophyllin obtained by artificial reduction of the green coloring matter. Monteverde used wheat, maize, and sunflower, extracting protochlorophyll and yellow pigments with 95 per cent alcohol. This extract when studied spectroscopically gave absorption bands as indicated below.

Band I, absorption of the extreme red rays to $\lambda 6800 \text{ \AA}$; band II, $\lambda 6400$ to 6200 \AA ; band III, $\lambda 5890$ to 5700 \AA ; end absorption $\lambda 5350 \text{ \AA}$. Monteverde considered band II the characteristic protochlorophyll band. Upon exposure of the etiolated leaves of wheat to diffuse light for 5 sec. with subsequent alcoholic extraction in the dark, band I of chlorophyll appeared, but weak in intensity. After exposure for 15 sec., the relative intensities of the bands were II *a*, I, III. After an exposure of 1 min., to diffuse light, band I was of greater intensity than II *a*.

After 10 min., the relative intensities of the bands were: I, II *a*, II *b*, III; band II *a* occurs between $\lambda 6300$ and 6220 \AA and band II *b* between $\lambda 6180$ and 6020 \AA . After 24 hr. band II *a* had disappeared completely. Monteverde gives a good review of the literature concerning protochlorophyll and the effect of radiation in chlorophyll formation. The fluorescence spectrum of protochlorophyll was investigated by Dhéré (11).

In 1912 Monteverde and Lubimenko (45) reported in Russian on the formation of chlorophyll and their conclusions are perhaps not so well known. They confirmed the observations of Monteverde to the effect that when etiolated plants are exposed to diffuse light for increasing intervals of time the amount of chlorophyll present increases while the amount of protochlorophyll decreases. By use of a microspectroscope the formation of chlorophyll by illumination of live, etiolated plants was studied. In the first moment of illumination two bands were observed: band I, $\lambda 7000$ to 6800 \AA ; band II, $\lambda 6500$ to 6300 \AA , or 6500 to 6250 \AA , depending on the concentration of the preparation. Band I after a short time changed to $\lambda 6800$ to 6600 \AA . At the same time band II soon disappeared, and after 5 to 10 sec., a band $\lambda 5650$ to 5500 \AA appeared. This was called band IV. Band III, $\lambda 5950$ to 5800 \AA , also appeared at about the same time. Thus, the first complete spectrum observed upon illumination was: band I, $\lambda 6800$ to 6600 \AA ; band II, $\lambda 6300$ to 6200 \AA ; band III, $\lambda 5950$ to 5800 \AA ; band IV, $\lambda 5600$ to 5400 \AA , the order of intensity being I, IV, III, II. A little later a band $\lambda 5100$ to 4800 \AA appeared. These observations were repeated with the use of dried, etiolated wheat plants and it was found that the same changes took place in the absorption as was found in that of the live plants, with one exception. In the dried, etiolated plants the band $\lambda 6300$ to 6200 \AA did not definitely disappear but remained visible no matter how long the illumination. The investigators believed that this band belonged to that part of the original pigment which was transformed into protochlorophyll prior to illumination, during the period of drying. After repeating these observations many times with live and dried wheat and luffa, they offer the following explanations for their observations: "In view of the facts described above, we have come to the conclusion that etiolated plants that cannot green in the darkness, form, in the absence of light, a special pigment having an absorption spectrum very much like chlorophyll. This pigment, under the influence of light, changes so that the result is the formation of chlorophyll or perhaps a pigment close to it. In such a way, from the point of view of the formation of chlorophyll, there is not much difference between those plants that can green and those that cannot green in darkness. Both types of plants form in darkness out of the colorless chromogen a certain pigment which we shall call 'chlorophyllogen.' The further change in this very unstable pigment is a transformation

into a more stable form, which is chlorophyll. The difference between the two types of plants is simply that in one case the transformation of chromogen into chlorophyll requires the action of light, while in the other case it can occur in the absence of light, entirely under the influence of chemical agents on the live tissue."

"In the case of plants which do green in darkness, it is not possible to observe directly the presence of protochlorophyll. But in some cases the presence of protochlorophyll may be observed, even in typical representatives of plants that green in darkness, like the pine. We have observed that after growing *Larix* and *Thuja* in darkness, and treating them with alcohol, one may identify protochlorophyll as well as chlorophyll. This fact indicates that in some cases the transformation of chlorophyllogen into chlorophyll is held up under the influence of unknown causes which make it possible to discover its presence by means of its derivative, protochlorophyll."

Thus Monteverde and Lubimenko believe chlorophyllogen is one of the group of unstable pigments which was found when they studied the inner envelopes of the pumpkin-like plants. They point out that their experiments with these plants have offered them ample opportunity to study both chlorophyllogen and protochlorophyll and the complete series of stages in the transformation of the chromogen into protochlorophyll or chlorophyll. Their concluding statements concerning the work with wheat, luffa, and pumpkin-like plants are: "The results of our investigations indicate with sufficient conviction that chlorophyll never arises immediately out of colorless chromogen. This very important fact unites, from the point of view of formation of chlorophyll, the plants which are able to green in darkness with the plants not having this property. At the same time it limits the role of light in the formation of chlorophyll. The facts described above prove that under the influence of light a new formation from a colorless substance does not occur, but only a change of a previously arisen pigment. From this point of view the formation of chlorophyll is not at all as simple a photochemical reaction as one might have thought from the latest investigations of Liro (36) and Issatschenko (29)."

Lubimenko (38) demonstrated the presence of chlorophyllogen in the leaves of etiolated plants. The two absorption bands found were $\lambda 7000$ to 6800 \AA and $\lambda 6500$ to 6300 \AA . Light causes the chlorophyllogen to become chlorophyll. Extraction of the living tissues with alcohol led to the protochlorophyll of Monteverde, which was considered an artificial transformation product. Chlorophyllogen seems to accumulate in plants which become green in the absence of light.

Lubimenko outlines the formation of chlorophyll by the following theory:

- a. Leucophyll (Sachs) $\xrightarrow{\text{catalytic reaction}}$ chlorophyllogen
- b. Chlorophyllogen $\xrightarrow{\text{catalytic reaction (enzyme)}}$ chlorophyll
or photochemical reaction (light)
- c. Chlorophyllogen $\xrightarrow{\text{decomposition in darkness}}$ protochlorophyll

In the photochemical reaction (b) blue light is less effective than red light.

Lubimenko and Hubbenet (39) summarize their conceptions of the greening process in the following steps: (a) Synthesis of leucophyll. (b) Transformation of leucophyll into chlorophyllogen. (c) Transformation of chlorophyllogen into chlorophyll. This transformation is a photochemical reaction. When wheat seedlings were used it was found that the influence of temperature on the synthesis of leucophyll and on the transformation of leucophyll into chlorophyllogen, independently of the exposure to light, began at a temperature of 2° to 4°C., reached a maximum between 26° to 30°C., and ceased near 48°C.

Eyster (17) concludes that protochlorophyll is not a decomposition product of some other organic substance, such as leucophyll, but is a pigment which develops without the influence of light and changes photochemically into chlorophyll upon exposure to light. He does not support the work of Monteverde and Lubimenko on the presence and importance of "chlorophyllogen."

Noack and Kiessling (47) believe that chlorophyll formation represents a photooxidation of protochlorophyll, the addition of oxygen bringing about the formation of chlorophyll *b*. It seems to the reviewers that this field is in need of much further work before the manner in which the plant builds up chlorophyll can be comprehended.

EFFECT OF RADIATION ON EXTRACTED CHLOROPHYLL

Gaffron (21) found that chlorophyll, dissolved in acetone and irradiated, takes up oxygen and is gradually oxidized. Upon addition of a suitable acceptor (one that does not absorb the radiation) the oxygen absorption is accelerated and the destruction of the chlorophyll is prevented. Gaffron used this experiment to check and confirm Einstein's equivalence law and Warburg's (82) conclusions that every quantum absorbed by chlorophyll, independently of its energy, causes the same chemical effect in the living plant. Literature on the oxidation of chlorophyll in acceptor-free solutions is quoted by Gaffron on page 761 of the paper mentioned above and in an article dealing with the chemical aspect of the reaction (21*a*). An explanation for such photooxidation of chlorophyll is given by Pfeilsticker (55), using the theory of photooxidation of anthraquinone for that purpose. Substances like gelatin or gums, which increase the stability of colloidal systems, also increase

the resistance of chlorophyll solutions to oxidation in light. Wurmser (88) has done a great deal of work on this shielding effect of the protective colloid and on the velocity of decolorization of chlorophyll solutions in radiations of different wave-lengths. He also determined the relationship between photochemical susceptibility and absorption constant in red, green, and violet light.

When chlorophyll in solution undergoes photooxidation, the process is accompanied by a gradual fading of the color of the solution and by the decrease of the intensity of the absorption bands. The chemistry of this change is still open to investigation, especially in respect to the formation of intermediate products. For the spectrum change of chlorophyll in the living leaf in light Wlodek (87) offers the explanation that either a change of the relative amounts of the two chlorophylls or the formation of unstable compounds between chlorophyll and carbon dioxide takes place. The bleaching of chlorophyll in solution and the products obtained under such conditions are the subject of a study by Wager (81). Although the formation of aldehydes was observed, the author himself doubts if the process going on *in vitro* actually takes place in nature.

Another phase of the influence of radiation on extracted chlorophyll was studied by Roffo (58). He prepared pure chlorophyll from alfalfa, exposed it to ultra-violet light and found that the radiation was gradually emitted again over a period of more than a month. Roffo points out that this photoactivity is similar to that of cholesterol.

Sensitization of chlorophyll can be brought about by irradiation with ultra-violet light, as Dixon (13) showed. He studied the photoelectric properties the chlorophyll acquires, and based a theory for photosynthesis upon his findings.

Rudolph (59) used the polarizing spectrophotometer of König and Martens in his investigation of the effect of colored light on the formation of chloroplast pigments. He determined the molar extinction coefficients of chlorophyll *a*, chlorophyll *b*, carotene, and xanthophyll, and the relative extinction coefficient of protochlorophyll at different wave-lengths. The influence of humidity, of leaf surface, of carbon dioxide, and of the age of the leaf on the formation of chlorophyll in light was studied, and interesting genetic relations between the pigments under investigation, especially between the carotinoids and chlorophyll *a* were found. An extensive bibliography is given.

BEHAVIOR OF CHLOROPHYLL UNDER THE INFLUENCE OF ULTRA-VIOLET RADIATION

Regarding the influence of radiation of short wave-lengths on chlorophyll in plants, whether the pigment is in the solid state or in solution, most investigators have found no appreciable decomposition of the pigment. Schulze (65) came to this conclusion, using radiation of

$\lambda 2800 \text{ \AA}$ on *Spirogyra*, *Cladophora*, *Nitella*, and *Tradescantia*. Kluver (32) found decomposition only after 55 to 60 hr. of irradiation with a mercury arc, and he believes that Schulze's experiments are very conclusive, since the ultra-violet radiation actually reached the chlorophyll without decomposing it. Kluver also reports no change if extracted, dried, irradiated, and redissolved chlorophyll is used. Stoklasa and coworkers (75) report the stability of chlorophyll solutions in ultra-violet light. Ursprung and Blum (79) found that the cells of green leaves from *Vicia Faba* are more resistant to ultra-violet light than those of etiolated leaves. Hertel (25) observed less damage done to chlorophyll-containing cells of *Elodea* and *Vallisneria* if visible and ultra-violet radiation are used simultaneously. While these authors emphasize the stability of chlorophyll in the living chloroplasts as well as in the form of solid precipitated material, or in concentrated or dilute alcoholic solutions, other authors come to the opposite conclusion. Bierry and Larguier des Bancels (4) reported decolorization of alcoholic chlorophyll solutions under prolonged irradiation with two mercury arcs. A recent publication by Richter (57) deals in part with chlorophyll decomposition under the influence of the quartz mercury arc. Richter uses the "Künstliche Höhensonne, Original Hanau" and finds that by $1\frac{1}{2}$ -hr. irradiation of leaves or parts thereof (from *Tropaeolum*, *Robinia Pseudacacia*, and *Iris florentina*) destruction of the chlorophyll has taken place, as indicated by the distinct yellow coloration characteristic of xanthophyll. Richter also finds that the chlorophyll destruction in irradiated autumnal leaves of *Tropaeolum majus* is smaller than in summer leaves and he explains this by the increased thickness of the epidermis and its resistance to radiation. In fall leaves the beginning decomposition of chlorophyll was studied by means of the fluorescence color analysis (analysis attachment to Bach's mercury lamp). This method allows differentiation of the degree of decomposition: it was found that the decomposition is more distinct in irradiation through the lower than through the upper epidermis. Richter observed that parts of yellow fall leaves exposed to light $\lambda < 3000 \text{ \AA}$ show deep green color owing to chlorophyll, while the unexposed parts remained yellow. For this preservation of chlorophyll in the autumnal leaves Richter gives two explanations: (I) Interruption of the communication of the sieve tubes, *e.g.*, due to precipitation reactions under the influence of ultra-violet light. Such a process would prevent the transportation of chlorophyll decomposition products and would fit well into Stahl's work (71) on interruption of sieve tubes and into Molisch's ideas (43). (II) If the autumnal decomposition of chlorophyll is caused by an enzyme, the complete destruction of this enzyme by ultra-violet light would account for the preservation of chlorophyll. The well-known red fluorescence of the chloroplasts (Gieckhorn, 22) is only visible in parts of the leaves or in solutions which have been protected from ultra-violet irradiation.

INFLUENCE OF FACTORS OTHER THAN RADIATION ON CHLOROPHYLL FORMATION

While it is hardly within the province of this paper to discuss the effects of various factors other than radiation upon the formation of chlorophyll, it is obviously worth while to include a brief statement of some of the other known factors, supplementary to illumination, influencing chlorophyll development. The extent of the available observations makes it necessary to select only representative instances.

The production of chlorophyll is affected by temperature, and Wiesner (84), using barley seedlings, gives data which support the conclusion that temperatures somewhat above ordinary room temperature are the most favorable, while with very low or very high temperatures there is no greening.

Gris (23) noted in 1844 that plants deprived of iron do not normally produce chlorophyll. Emerson (15) cultivated *Chlorella* in pure cultures using Warburg's medium with glucose. By varying the amounts of iron used in the culture medium the chlorophyll content differed widely. Oddo and Pollacci (50) grew plants of *Zea Mays*, *Solanum nigrum*, *Datura Stramonium*, *Euphorbia* sp., and *Aster sinensis* in a standard nutrient solution lacking iron but containing the magnesium salt of pyrrole- α -carboxylic acid, and found chlorophyll formation. Deuber (9) was unable to confirm this work with corn, cowpea, soy bean, and *Spirodela*. Sideris (68) reported that titanium trichloride could be substituted for iron in the formation of chlorophyll in the growth of pineapples. The chemical form in which the iron is presented to the plant seems to make little difference so long as the pH is kept such that there is a soluble iron compound available at all times. Marsh and Shive (41) studied this problem with soy beans and found that ferric glycerophosphate, soluble ferric phosphate, ferric tartrate, and ferrous tartrate vary in their availability depending on the pH of the media. Hopkins and Wann (28a), using *Chlorella*, also showed clearly that the availability of the iron for the plant is closely related to the hydrogen ion concentration of the media at the various stages of growth. According to Densch and Humnius (8), copper may replace the iron at least partially in the chlorophyll synthesis.

That the absence of necessary mineral salts in the soil results in the diminution of the chlorophyll and carotene contents of the leaves was stated by Ville (80). Maiwald (40) found that the amount of potassium salts used as fertilizer greatly influenced the intensity of the greening in the leaves of the potato. If large amounts of potash were applied, the leaves turned yellow. In 1929 Schertz (64) confirmed these results of Maiwald. Another essential element affecting chlorophyll development is manganese. McHargue (42) observed that wheat seedlings grown in manganese-free Pfeffer's nutrient salt solution grow normally

for the first six or eight weeks, but after this time the development of chlorophyll is retarded and the plants become yellow and stunted. Chiefly on theoretical grounds McHargue concludes that manganese plays a role in the synthesis of proteins, functions as a catalyst in plant metabolism, and also acts with iron in the synthesis of chlorophyll.

Kostychev (33) demonstrated that excess of certain minerals in the soil may cause diminution of the chlorophyll content of plants. He found that fruit trees which had become accustomed to soils poor in lime showed chlorosis when grown on soils which had been heavily irrigated with lime water.

It has long been known that plants are unable to build up chlorophyll without the presence of oxygen. Friedel (20), using *Lepidium sativum* seedlings, found that in one-half atmospheric pressure normal greening took place, but under one-fifth normal pressure there was a greatly diminished formation of chlorophyll. Similar results were obtained with *Phaseolus multiflorus*. It should be pointed out that this question is closely related to the one raised by Pfeffer, Liro, and Lubimenko as to the part the living cells play in the formation of chlorophyll. Interesting relations between nitrogen and chlorophyll content of leaves in autumn were recently elucidated by Hilpert and Heidrich (26).

Palladin (51) pointed out that carbohydrates are essential to the formation of chlorophyll since etiolated leaves which contain appreciable amounts of soluble carbohydrates green rapidly when illuminated, while those which contain little or no soluble carbohydrates remain yellow. If, however, these yellow leaves are floated on a solution of glucose or cane sugar, rapid greening occurs. Senn (66) found that etiolated leaves of corn and beans floated on sugar solutions of different concentrations, under illumination, will not turn green in low light intensities and strong sugar solutions. Strong light, however, counteracts this effect. It has been shown that *Chlorella*, if glucose is added to the nutrient media, will form chlorophyll in the dark and, if one wished to speculate on this matter, it may be considered possible that any cell which is inherently capable of forming chlorophyll in the light could, if constructed for absorbing soluble carbohydrates, form chlorophyll in absolute darkness. This was apparently not so far from the minds of Monteverde and Lubimenko in their ideas on the relative effects of photochemical and strictly chemical formation of chlorophyll in the living plant.

YELLOW PIGMENTS ASSOCIATED WITH CHLOROPHYLL

Yellow pigments are always present in green leaves. In the literature carotene and xanthophyll are usually mentioned. Palmer's monograph (52) gives a detailed account of the carotinoids and related pigments to the year 1922. During the last few years, however, our knowledge of the yellow pigments has increased considerably. Thus, three different forms

of carotene are now known; they are unsaturated hydrocarbons of the formula $C_{40}H_{56}$.

The name xanthophyll was given by Berzelius (3a) to the yellow pigment from leaves. It is a hydroxyl-containing carotenoid of the formula $C_{40}H_{56}O_2$. Two recent suggestions for the nomenclature of the oxygen-containing yellow pigments are the following:

Kuhn (35) uses the term xanthophyll as a group name for the hydroxyl-containing carotenoids of the C_{40} series. Kuhn in agreement with Willstätter has changed the name of the leaf xanthophyll ($C_{40}H_{56}O_2$) to lutein. Von Euler uses the term lutein for the natural mixture of pigments in egg yolk.

Karrer (30) suggests that the name xanthophyll be reserved for the carotenoid $C_{40}H_{56}O_2$ from the green leaf (= Kuhn's "lutein") and that the oxygen-containing carotenoids with 40 carbon atoms be called phytoxanthins. The names of the individual substances are then to be formed in connection with the place of formation of these substances, e.g., xanthophyll from the green leaf, zeaxanthin from *Zea Mays*, violaxanthin, taraxanthin, and fucoxanthin.

Von Euler and Hellström (16a) germinated barley grains in the dark and then exposed them to light. During illumination the increase in carotene and in chlorophyll content go closely parallel and at a higher rate than xanthophyll. In etiolated plants practically no carotene was found. Chlorophyll and carotene formation are apparently photochemical reactions. Sjöburg (69) studied the formation of chlorophyll and the yellow plant pigments under varying conditions and at different stages of the development of the plants. The formation of carotenoids and anthocyanins in the blossoms was the same in light and darkness. Guthrie (24) studied the effect of environmental conditions on chloroplast pigments. Some of his results may be noted: (a) Increasing the duration of illumination results in a decrease in total chlorophyll and carotenoids as measured on the dry-weight basis. (b) Screening out the ultra-violet light from sunlight has no significant effect on chlorophyll or carotenoids. (c) Screening out the red light results in an increase in both chlorophyll and carotenoids, but this is partially due to intensity reduction. The ratio chlorophyll *a*:chlorophyll *b* is higher under blue light, but the number of analyses was insufficient to be certain of this increase. Brown pigment production is favored by blue light. (d) Reducing the light intensity to 12 per cent of normal sunlight results in an increase in chlorophyll and carotenoids. The chlorophyll *a*:chlorophyll *b* and carotene:xanthophyll ratios show no significant change. Brown pigment is reduced. (e) Placing plants in the dark results in a large decrease in chlorophyll unaccompanied by a corresponding decrease in carotenoids. The carotene:xanthophyll ratio shows a marked increase. Brown pigment increases.

Willstätter and Mieg (85) found that the carotene content of leaves varies with the season of the year; the greatest amount was found in stinging nettle and horse-chestnut leaves during the flowering season of both plants. The formation of carotene seems also to be influenced by light.

Parallelism between the rate of development of chlorophyll and of xanthophyll in visible light was reported by Norris (49). He was able to develop xanthophyll independently of carotene by controlling oxygen tension, and he also found that minimum oxygen tensions are necessary for the development of each pigment.

REFERENCES

1. ARTARI, A. Über die Entwicklung der grünen Algen unter Ausschluss der Bedingungen der Kohlensäureassimilation. Bull. Soc. Imp. des Naturalistes [Moscow] **13**: 39-47. 1900.
2. ARTARI, A. Zur Ernährungsphysiologie der grünen Algen. Ber. Deut. Botan. Ges. **19**: 7-9. 1901.
3. BERZELIUS, J. Über die gelbe Farbe der Blätter im Herbst. Ann. Chem. [Liebig's] **21**: 257-262. 1837. (See also (a) Ibid. **27**: 296-318. 1838.)
4. BIERRY, H., and J. LARGUIER DES BANCELS. Action de la lumière émise par la lampe à mercure sur les solutions de chlorophylle. Compt. Rend. Acad. Sci. [Paris] **153**: 124-125. 1911.
5. BURGERSTEIN, A. Über das Verhalten der Gymnospermen-Keimlinge im Lichte und im Dunkeln. Ber. Deut. Botan. Ges. **18**: 168-184. 1900. [Bibliography.]
6. CONANT, J. B., and EMMA M. DIETZ. The position of the methoxyl group. Jour. Amer. Chem. Soc. **55**: 839-849. 1933. [See also a series of papers by Conant and collaborators, of earlier date, in Jour. Amer. Chem. Soc.]
7. DANGEARD, P. A. Recherches sur l'assimilation chlorophyllienne et les questions qui s'y rattachent. Botaniste **19**($\frac{1}{6}$): 1-397. 1927.
8. DENSCHE, A., and T. HUNNIUS. Versuche mit Kupfersulfat. Zeitsch. Pflanzenernähr. Düngung Teil A. **3**: 369-386. 1924.
9. DEUBER, C. G. Can a pyrrole derivative be substituted for iron in the growth of plants? Amer. Jour. Bot. **13**: 276-285. 1926.
10. DHAR, N. R. The chemical action of light. Blackie and Son Limited; London and Glasgow, 1931. [Extensive bibliography.]
11. DHÉRÉ, CH. Sur le spectre de fluorescence de la protochlorophylle. Compt. Rend. Acad. Sci. [Paris] **192**: 1496-1499. 1931.
12. DIXON, H. H., and N. G. BALL. Photosynthesis and the electronic theory, II. Sci. Proc. Royal Dublin Soc. **16**: 435-441. 1920-22.
13. DIXON, H. H., and H. H. POOLE. Photosynthesis and the electronic theory. Sci. Proc. Royal Dublin Soc. **16**: 63-77. 1920-22.
14. ELLIS, C., and A. A. WELLS. The chemical action of ultraviolet rays. Chem. Catalog Co.; New York, 1925. [Extensive bibliography.]
15. EMERSON, R. The relation between maximum rate of photosynthesis and concentration of chlorophyll. Jour. Gen. Physiol. **12**: 609-622. 1929.
16. EULER, H. VON, and H. HELLSTRÖM. Über die Bildung von Xanthophyll, Carotin und Chlorophyll in belichteten und unbelichteten Gerstenkeimlingen. Zeitsch. Physiol. Chem. **183**: 177-183. 1929. (See also (a) Ibid. **208**: 43-49. 1932.)
17. EYSTER, W. H. Protochlorophyll. Science **68**: 569-570. 1928.

18. FAMINTZIN, A. Die Wirkung des Lichtes auf das Ergrünen der Pflanzen. Mélanges Biol. Acad. Imp. Sci. St.-Pétersbourg **6**: 94-100. 1866. [Cf. Palladin, Engl. transl. p. 14. 1918.]
19. FISCHER, H., S. BREITNER, A. HENDSCHEL, and L. NÜSSLER. Über Chlorophyll *b*. Ann. Chem. [Liebig's] **603**: 1-40. 1933. [See also numerous earlier papers by Fischer and coworkers, chiefly in Annalen Chem. (Liebig's).]
20. FRIEDEL, J. Formation de la chlorophylle, dans l'air raréfié et dans l'oxygène raréfié. Compt. Rend. Acad. Sci. [Paris] **135**: 1063-1064. 1902.
21. GAFFRON, H. Sauerstoff-Übertragung durch Chlorophyll und das photochemische Äquivalenzgesetz. Ber. Deut. Chem. Ges. **60B**: 755-766. 1927. [See also (a) *Ibid.* **60B**: 2229-2238. 1927.]
22. GICKLHORN, J. Über den Einfluss photodynamisch wirksamer Farbstofflösungen auf pflanzliche Zellen und Gewebe. Sitzungsber. Akad. Wiss. Wien (Math.-Naturw. Kl., Abt. 1) **123**: 1221-1276. 1914.
23. GRIS, E. Nouvelles expériences sur l'action des composés ferrugineux solubles, appliqués à la végétation, et spécialement au traitement de la chlorose et de la débilité des plantes. Compt. Rend. Acad. Sci. [Paris] **19**: 1118-1119. 1844.
24. GUTHRIE, J. Effect of environmental conditions on the chloroplast pigments. Amer. Jour. Bot. **16**: 716-746. 1929.
25. HERTEL, E. Über Beeinflussung des Organismus durch Licht, speziell durch die chemisch wirksamen Strahlen. Zeitsch. Allgem. Physiol. **4**: 1-43. 1904. (See also (a) *Ibid.* **5**: 95-122. 1905.)
26. HILPERT, R. S., and K. HEIDRICH. Über Beziehungen zwischen Stickstoff- und Chlorophyll-Gehalt bei natürlicher und krankhafter Vergilbung der Blätter. Ber. Deut. Chem. Ges. **67**: 1077-1081. 1934.
27. HILPERT, S., H. HOFMEIER, and A. WOLTER. Über den Zustand des Chlorophylls in der Pflanze. Ber. Deut. Chem. Ges. **64**: B: 2570-2577. 1931.
28. HOPKINS, E. F., and F. B. WANN. Relation of hydrogen-ion concentration to growth of *Chlorella* and to the availability of iron. Botan. Gaz. **81**: 353-376. 1926. (See also (a) *Ibid.* **84**: 407-427. 1927.)
29. ISSATSCHENKO, B. Sur les conditions de la formation de la chlorophylle. Bull. Jard. Imp. Bot. St.-Pétersbourg. **9**: 106-120. 1909.
30. KARRER, P., and A. NOTTHAFFT. Pflanzenfarbstoffe. XLIII. Zur Kenntnis der Carotinoide der Blüten. Helv. Chim. Acta **15**: 1195-1204. 1932.
31. KRISTIAKOWSKY, G. B. Photochemical processes. Chem. Catalog Co., New York, 1928. [Extensive bibliography.]
32. KLUYVER, A. J. Beobachtungen über die Einwirkung von ultravioletten Strahlen auf höhere Pflanzen. Sitzungsber. Akad. Wiss. Wien (Math.-Naturw. Kl. Abt. 1) **120**: 1137-1170. 1911.
33. KOSTYCHEV, S. Kostychev's chemical plant physiology. English transl. by C. J. Lyon. Philadelphia, 1931. [Bibliography.]
34. KUHN, R., and H. BROCKMANN. Flavoxanthin. Zeitsch. Physiol. Chem. **213**: 192-198. 1932.
35. KUHN, R., and E. LEDERER. Über Taraxanthin. Zeitsch. Physiol. Chem. **213**: 188-191. 1932.
36. LIRO, J. I. Über die photochemische Chlorophyllbildung bei den Phanerogamen. Suomalaisen Tiedeakatemia Toimituksia. Ann. Acad. Sci. Fennicae [Helsinki] A, **1**: 1-147. 1909. [Title page of paper: 1908.]
37. LLOYD, F. E. The fluorescent colors of plants. Science **59**: 241-248. 1924.
38. LUBIMENKO, V. N. Les pigments des plantes et leur transformation dans les tissus vivants de la plante. Rev. Gén. Bot. **40**: (470): 88-94. 1928.
39. LUBIMENKO, V. N., and E. R. HUBBENET. The influence of temperature on the rate of accumulation of chlorophyll in etiolated seedlings. New Phytologist **31**: 26-57. 1932.

40. MAIWALD, K. Wirkung hoher Nährstoffgaben auf den Assimilationsapparat. *Angew. Bot.* **5**: 33-48, 49-74. 1923.
41. MARSH, R. P., and J. W. SHIVE. Adjustment of iron supply to requirements of soy bean in solution culture. *Botan. Gaz.* **79**: 1-27. 1925.
42. MCHARGUE, J. S. The role of manganese in plants. *Jour. Amer. Chem. Soc.* **44**: 1592-1598. 1922.
43. MOLISCH, H. Über die Vergilbung der Blätter. *Sitzungsber. Akad. Wiss. Wien (Math.-Naturw. Kl. Abt. I)* **127**: 3-34. 1918.
44. MONTEVERDE, N. A. Über das Protochlorophyll. *Acta Horti Petropolitani* **13**: 201-217. 1893-1894.
45. MONTEVERDE, N. A., and V. N. LUBIMENKO. Formation of chlorophyll in plants. *Bull. Acad. Sci. St.-Petersbourg.* VI, **5**: 73-100. 1911; VI, **6**: 609-630. 1912; VI, **7**: 1007-1028. 1913.
46. NOACK, K. Der Zustand des Chlorophylls in der lebenden Pflanze. *Biochem. Zeitsch.* **183**: 135-152. 1927.
47. NOACK, K., and W. KIESSLING. Zur Entstehung des Chlorophylls und seiner Beziehung zum Blutfarbstoff. I. *Zeitsch. Physiol. Chem.* **182**: 13-49. 1929; II. **193**: 97-137. 1930.
48. NOACK, K., and W. KIESSLING. Zur Kenntniss der Chlorophyllbildung. *Zeitsch. Angew. Chem.* **44**: 93-96. 1931.
49. NORRIS, R. J. Observations on the development of chlorophyll and carotinoid pigments in etiolated plants. *Bull. Basic Sci. Res. [Cincinnati]* **5**: 23-32. 1933.
50. ODDO, B., and G. POLLACCI. Influenza del nucleo pirrolico nella formazione della clorofilla. *Gaz. Chim. Ital.* **50**: 54-70. 1920.
51. PALLADIN, V. I. *Plant physiology.* English transl. ed. by B. E. Livingston. Philadelphia, 1926.
52. PALMER, L. S. Carotinoids and related pigments. *Chem. Catalog Co., New York*, 1922.
53. PELLETIER and CAVENTOU. Sur la matière verte des feuilles. *Ann. Chim. et Phys. Sér. 2*, **9**: 194-196. 1818.
54. PFEFFER, W. *Physiology of plants.* Vol. I. English transl. by A. J. Ewart. Oxford, 1900.
55. PFELSTICKER, K. Eine Theorie zur Photosynthese. *Biochem. Zeitsch.* **199**: 12-20. 1928.
56. PREISSER, F. Über den Ursprung und die Beschaffenheit der organischen Farbstoffe und besonders über die Einwirkung des Sauerstoffs auf dieselben. *Jour. Prakt. Chem.* **32**: 129-164. 1844. [p. 162 "Chlorophyll oder Blattgrün".]
57. RICHTER, O. Neue Beiträge zur Photosynthese und Photolyse vornehmlich an der lebenden Pflanze. *Deusch. Akad. Wiss. Wien (Math.-Naturw. Kl.)* **103**: 163-209. 1932.
58. ROFFO, A. H. Photoaktivität des Chlorophylls. *Strahlentherapie* **45**: 115-124. 1932. [Bibliography.]
59. RUDOLPH, HORST. Über die Einwirkung des farbigen Lichtes auf die Entstehung der Chloroplastenfarbstoffe. *Planta* **21**: 104-155. 1933.
60. SACHS, J. *Handbuch der Experimental-Physiologie der Pflanzen.* Leipzig, 1865. [See also *Lectures on the physiology of plants.* English transl. Oxford, 1887.]
61. SACHS, J. Über das Vorhandensein eines farblosen Chlorophyll-Chromogens in Pflanzentheilen, welche fähig sind grün zu werden. *Lotos* **9**: 6-14. 1859.
62. SACHS, J. Übersicht der Ergebnisse der neueren Untersuchungen über das Chlorophyll. *Flora* **45**: 129-137, 161-170, 177-186, 209-221. 1862.
63. SAYRE, J. D. The development of chlorophyll in seedlings in different ranges of wave lengths of light. *Plant Physiol.* **3**: 71-77. 1928.

64. SCHERTZ, F. M. The effect of potassium, nitrogen and phosphorus fertilization upon the chloroplast pigments, upon the mineral content of the leaves, and upon production in crop plants. *Plant Physiol.* **4**: 269-279. 1929.
65. SCHULZE, J. Über die Einwirkung der Lichtstrahlen von 280 m μ Wellenlänge auf Pflanzenzellen. *Beih. Botan. Centralbl. Abt. 1.* **25**: 30-61. 1910.
66. SENN, G. Die Chlorophyll-Armut saprophytischer Orchideen nebst Versuchen über den Einfluss des Stärkegehalts auf die Chlorophyllbildung. *Verhandl. Naturforsch. Ges. Basel* **38**: 516-526. 1926-1927.
67. SHIRLEY, H. L. The influence of light intensity and light quality upon the growth of plants. *Amer. Jour. Bot.* **16**: 354-390. 1929.
68. SIDERIS, C. P. Titanium replacing the iron essential in plant growth. *Pineapple News* **4** (6): 98-100. 1930.
69. SJÖBURG, K. Beitrag zur Kenntnis der Bildung des Chlorophylls und der gelben Pflanzenpigmente. *Biochem. Zeitsch.* **240**: 156-186. 1931.
70. SPOEHR, H. A. *Photosynthesis.* Chem. Catalog. Co.; New York, 1926.
71. STAHL, E. *Zur Biologie des Chlorophylls.* Gustav Fischer; Jena, 1909.
72. STERN, K. Untersuchungen über Fluoreszenz und Zustand des Chlorophylls in lebenden Zellen. *Ber. Deut. Botan. Ges.* **38**: 28-35. 1920.
73. STILES, W. *Photosynthesis.* London, 1925.
74. STOKES, G. G. On the supposed identity of Biliverdin with chlorophyll, with remarks on the constitution of chlorophyll. *Proc. Roy. Soc. [London]* **13**: 144-145. 1864.
75. STOKLASA, J. Über den Einfluss der ultravioletten Strahlen auf die Vegetation. *Sitzungsber. Akad. Wiss. Wien (Math.-Naturw. Kl. Abt. 1)* **120**: 195-216. 1911.
76. STOLL, A., and E. WIEDEMANN. Die optische Aktivität des Chlorophylls. *Helv. Chim. Acta* **16**: 307-314. 1933. [Earlier papers in same journal and in *Naturwissenschaften.*]
77. TIMIRIAZEFF, C. La protophylline dans les plantes étiolées. *Compt. Rend. Acad. Sci. [Paris]* **109**: 414-416. 1889. (*See also* (a) *Ibid.* **120**: 467-470. 1895.)
78. TSWETT, M. Physikalisch-chemische Studien über das Chlorophyll. Die Adsorptionen. *Ber. Deut. Botan. Ges.* **24**: 316-323. 1906. (*See also* *Ibid.* **24**: 384-393. 1906; (a) *Ibid.* **29**: 744-746. 1911.)
79. URSPRUNG, A., and G. BLUM. Über die Schädlichkeit ultravioletter Strahlen. *Ber. Deut. Botan. Ges.* **35**: 385-402. 1917.
80. VILLE, G. Recherches sur les relations qui existent entre la couleur des plantes et la richesse des terres en agents de fertilité. *Compt. Rend. Acad. Sci. [Paris]* **109**: 397-400. 1889.
81. WAGER, H. The action of light on chlorophyll. *Proc. Roy. Soc. [London]* **B. 87**: 386-407. 1914.
82. WARBURG, O., and E. NEGELEIN. Über den Energieumsatz bei der Kohlensäureassimilation. *Zeitsch. Physik. Chem.* **102**: 235-266. 1922. (*See also* (a) *Ibid.* **106**: 191-218. 1923.)
83. WIESNER, J. I. Untersuchungen über die Beziehungen des Lichtes zum Chlorophyll. *Sitzungsber. Akad. Wiss. Wien (Math.-Naturw. Kl.)* **69**: 327-385. 1874. [Bibliography.]
84. WIESNER, J. I. Die Entstehung des Chlorophylls in der Pflanze. Eine physiologische Untersuchung. Wien, 1877.
85. WILLSTÄTTER, R., and W. MIEG. Über die gelben Begleiter des Chlorophylls. *Annalen Chem. [Liebig's]* **355**: 1-28. 1907.
86. WILLSTÄTTER, R., and A. STOLL. Investigations on chlorophyll. English transl. by F. M. Schertz and A. R. Merz. Lancaster, Pa. 1928.
87. WLODEK, J. The spectrum of chlorophyll in the living leaf. *Bull. Internat. Acad. Polonaise Krakow Ser. B. Sci. Nat.* 1924: 407-423. 1924.

88. WURMSER, R. Action sur la chlorophylle des radiations de différentes longueurs d'onde. *Compt. Rend. Acad. Sci. [Paris]* **170**: 1610-1612. 1920. [See bibliographies in articles by the same author as follows: *Arch. Phys. Biol.* **1** (3): 33-141; *Recherches sur l'assimilation chlorophyllienne*. Vigot Frères; Paris, 1921; *Oxidations et réductions*. Les Presses Universitaires de France; Paris, 1930.]
89. ZIMMERMANN, A. *Die Morphologie und Physiologie der Pflanzenzelle*. Breslau, 1887.
90. ZIRKLE, C. The Structure of the chloroplast in certain higher plants. *Amer. Jour. Bot.* **13**: 301-320, 321-341. 1926.

Manuscript received by the editor July, 1933.

RADIATION AND ANTHOCYANIN PIGMENTS

JOHN M. ARTHUR

Boyce Thompson Institute for Plant Research

Introduction. Light and anthocyanin pigments. Carbohydrate accumulation and anthocyanin development. Relation of anthocyanin production to environment. Temperature, radiation, and anthocyanin formation. Absorption and transmission of anthocyanin pigments. Conclusion. References.

INTRODUCTION

The eye of man was attracted, probably from the beginning, by the bright pigments of plant leaves, flowers, and fruit. The first studies of these pigments, therefore, date back to the first studies on the physiology of plants. In 1664, Robert Boyle (8) recorded his observations that syrup of violets turned red when vinegar or any other acid liquor was added. Since that time the bibliography on this subject has accumulated at a rapid rate. Onslow (25) has published a book on the anthocyanin pigments which gives 879 references to publications on this single group up to the year 1925 and this is by no means complete. Möbius (25), in 1927, published a monograph on various kinds of plant pigments. This publication includes more than 300 references. In general, the possibility of formation of pigments is largely determined by hereditary factors. The degree of pigmentation may be, and often is, determined by environmental factors. For a discussion of factors other than light which affect pigment formation, the reader should consult the book by Onslow mentioned above.

The effect of light and darkness on some of the red and blue anthocyanin pigments was observed in 1799 by Senebier (32). Crocus and tulip flowers he found developed pigment in the dark. Sachs (28) confirmed the work of Senebier and added iris and hyacinth to the list of flowers developing pigment in the dark. Sachs also found another group of flowers which developed color only if the buds were exposed to light until the time of opening. *Brassica*, *Tropaeolum*, *Papaver*, and *Cucurbita* were included in this list. Where shoots only of these plants were darkened, the flowers which developed upon these had a less brilliant coloration. Sorby (33) studied the absorption bands of extracted pigments as well as the development of colors in the plants. He observed that the production of red pigment in leaves often depended upon light, since a leaf, when partially covered by an opaque screen, such as another leaf, did not develop pigment under that screen. Sorby was

impressed by the curious fact that chlorophyll and the red pigments formed by light were also decomposed again by the same agency. On account of the immediate appearance of red and yellow pigments upon the disappearance of chlorophyll in the fall he was led to believe that these pigments were formed by the decomposition products of chlorophyll. This confusion of ideas persisted until recently when the chemical identity of chlorophyll and of the red and yellow pigments was established by Willstätter (34) and others. More recently the chemical synthesis of many of the anthocyanins has been accomplished. This work has been critically discussed and summarized by Karrer and Helfenstein (16). The apparent production of yellow pigments in autumn leaves, citrus fruit, and elsewhere as chlorophyll disappears should not be confused with the production of pigment by the direct action of light. Often the yellow pigments, carotene and xanthophyll, already exist in such leaves and fruit but are masked by the presence of chlorophyll. When the chlorophyll is decomposed by light or other agency the yellow pigment remains, and this results in a rapid change of color from green to orange or yellow. In some roots, flowers, and fruits the carotenoid pigments are developed in the complete absence of chlorophyll. The effect of radiation on the development of the carotenoid pigments, as well as its effect on chlorophyll development, is considered elsewhere in this monograph. The present discussion is limited to the anthocyanins.

LIGHT AND ANTHOCYANIN PIGMENTS

Askenasy (3), Beulaygue (5), and Gertz (14) studied the development of red pigments in several flowers and leaves kept in darkness and found that these pigments were often greatly reduced or failed to develop entirely in some species in darkness. Onslow (25) has listed various organs of a number of plants which form anthocyanin in darkness and has also given a similar list in which light appears necessary for the formation of pigment. Gertz found that autumn-colored leaves of various species of *Viburnum*, *Cornus*, and *Prunus* often showed natural photographs of the leaves covering them. Anthocyanin pigments developed only on those cells which were exposed to light. Linsbauer (19) working with etiolated buckwheat seedlings (*Fagopyrum esculentum*) found that the amount of pigment developed when exposed to a lamp depended upon both the intensity and the time of exposure.

CARBOHYDRATE ACCUMULATION AND ANTHOCYANIN DEVELOPMENT

Onslow (25, page 90) pointed out that it is difficult to determine in the experiments of Linsbauer whether the appearance of anthocyanin is due to the direct action of light or to the products of photosynthesis induced by light. This confusion of the factors producing anthocyanin exists in both the older and later literature on the subject. Onslow

(25, pages 83–86) discussed critically the older literature which presents the evidence that carbohydrate and especially sugar accumulation in plants induce pigment formation. Later papers by Sando (29), Emerson (12), Magness (20), Fletcher (13), and others present further evidence of a similar nature or assume that pigment production is increased by the accumulation of the products of photosynthesis. It should be pointed out, however, that the citation of a number of cases where high carbohydrate content accompanies pigment formation does not prove that such an accumulation causes pigment production. The fact that each molecule of anthocyanin contains normally one or two molecules of sugar makes the above cause and effect relation seem logical, from a chemical point of view. We should not lose sight of the fact, however, that we are dealing with living cells where sometimes reactions take place which are not at all logical from a chemical point of view, and conversely where reactions may not take place although all necessary products are present. When it is recalled that the anthocyanin in any plant probably represents only a very small fraction of the dry weight of the entire plant as compared with 10 to 20 per cent of easily available carbohydrate, any limitation of pigment formation due to a shortage of carbohydrate is unlikely. Although Willstätter and Mallison (35, page 153) have shown that the most highly pigmented part of a dark-red dahlia flower may contain as high as 30 per cent pigment on a dry-weight basis, this localized area contains only a small fraction of the total available carbohydrate content of the plant. Such high concentrations of pigment even in localized areas appear exceptional in plant tissues. Most of the pigment concentration values given by Willstätter and Mallison for other highly colored flower parts are less than 10 per cent of the dry weight. In many fruits, stems, and leaves where pigment is present only in the first few layers of cells beneath the epidermis the concentration is no doubt only a small fraction of this. In contrast with the accumulation-of-products theory as a cause for pigment formation, Combes (9) and Combes and Kohler (10) found a decrease in both nitrogen and carbohydrate fractions in leaves during the autumnal development of pigment. Murneek and Logan (24) reviewed the literature on the subject and studied the migration of both nitrogen and carbohydrate from several varieties of apple leaves. They found that nitrogen decreases from the time active growth ceases until complete defoliation occurs, but there was no definite trend established in the migration of carbohydrates from the foliage. Denny (11) by means of the twin-leaf method made a careful study of the trends of both carbohydrate and nitrogen fractions in *Viburnum* and lilac. He found a definite decrease only in nitrogen and that only in the case of *Viburnum*. No trend was established for nitrogen in lilac leaves or for carbohydrates in either species during the autumn-migration period. Of the two species only *Viburnum* showed

autumnal reddening of leaves. From the foregoing literature the only change in the carbohydrate and nitrogen fractions of leaves which redden during autumn which has been consistently observed by the various workers is loss of nitrogen. It might be concluded, therefore, that loss of nitrogen from leaves is a cause of pigment formation, but when the variations in the different fractions with species just mentioned are considered, it seems as logical to conclude that further careful analytical work may reveal some exceptions even in the case of loss of nitrogen.

RELATION OF ANTHOCYANIN PRODUCTION TO ENVIRONMENT

In a multiconditioned natural environment it is always difficult to determine which factor or factors affect a given process in plants. This is true of pigment formation. In order to determine more accurately the part which each factor plays in the development of pigment much progress might be made by growing many species of plants which form pigment in an artificial climate where various climatic factors were carefully controlled. So far this has not been done. In the absence of such a study some information may be gained by a consideration of work with various separate plant organs such as leaves, fruits, stems, and bulb scales held under more accurately controlled conditions.

Mirande (21) observed that the bulb scales of lilies produced a red pigment when removed and exposed to diffuse daylight or to artificial light. The scales were exposed under one to six layers of white silk transmitting from 0.53 to 0.07 of the intensity of sunlight as measured by a photometer. At an altitude of 300 meters the reddening did not take place in open sunlight or under one layer of cloth, but started under two layers and reached a maximum under three layers. At 600 meters the reddening began under three layers and reached a maximum under four layers. At 2000 meters the reddening started under three and four layers and reached a maximum under six layers. In diffuse light pigment is developed under glass-water filters and also under a solution of alum in glass used as a filter, showing that the extreme ultra-violet and infra-red regions are not required. Pigment is not developed under these filters in open sunlight. The author concludes, therefore, that the active rays are in the visible region. By means of various filters (liquid, colored glass, and Wratten) Mirande found that the blue-violet region was most effective in producing color and the red was second in importance, while the green produced no color. It is evident from the foregoing that even a reduced intensity of light in the blue-violet region is effective in producing red pigment on the bulb scales of lily. Since temperatures were not controlled in these tests, there is the possibility that higher temperatures inhibited pigment formation in the open sunlight as well as high light intensity, while both lower temperatures and higher light intensities which usually obtain in the higher altitudes might

favor pigment formation. The author observed that the scales withered rapidly in the open sunlight.

TEMPERATURE, RADIATION, AND ANTHOCYANIN FORMATION

Anthocyanin pigments in nature develop best in the spring and autumn when temperatures are lowest. Overton (26) found that the higher the temperature the less pigment was formed in *Hydrocharis* leaves. Klebs (17) also observed that flowers of *Primula sinensis* and *Campanula trochelium* were more highly colored when grown in the cold. Bonnier (7) and Heckel (15) have noted the increased pigmentation of flowers grown at high altitudes as compared with those grown in lowlands. Many workers have discounted the possible direct effect of low temperatures on anthocyanin formation, preferring to believe that the effect is due to the accumulation of the products of photosynthesis, especially sugars, at low temperatures. In the case of autumnal coloring of leaves it has been pointed out above that no definite proof of such an accumulation exists in the period during which color develops. The evidence here is largely in favor of a low temperature effect on pigment production or of other factors not yet studied thoroughly. Kosaka (18) has studied recently the effect of both low temperature and light intensity on pigment development in chrysanthemum flowers. The pigment was developed only in light. Using shading cloth he determined that lower light intensities produced less color. Low temperatures of 7° to 15°C. favored, while higher temperatures of 25° to 30°C. inhibited, pigment development.

Many fruits develop red color only in light. In others pigment production is aided by exposure to light. Fletcher (13) found that when growing apples were bagged while on the tree in red cellophane bags which had a low transmission in the blue region, red pigment failed to develop. If the fruit was bagged late in the growing season, color developed more rapidly than in nontreated fruit when the bag was removed at maturity and the fruit exposed to sunlight. Schrader and Marth (31) found that a single layer of muslin greatly reduced pigment formation in five varieties of red apples, while two layers almost completely prevented pigment formation. The transmission of the cloth as measured with a Weston photronic-cell photometer was 61.4 per cent for one layer and 39.2 per cent for two layers.

Recent studies have shown that red pigment may be developed in certain varieties of apples after these have been detached from the tree. Magness (20) found that Jonathan apples were colored by exposures of 1 hr. each day to "dilute ultra-violet light." Greater exposures injured the fruit. He also observed that fruit did not color so rapidly when exposed to sunlight through window glass as when exposed directly. Holding the fruit in storage for two weeks retarded pigment develop-

ment when subsequently exposed to sunlight. Pearce and Streeter (27) studied the development of color in apples under various filters using sunlight as a source. They found that the region between $\lambda 3600$ and 4500 \AA was effective in producing color. The optimum they determined at or near $\lambda 4100 \text{ \AA}$. They concluded that ordinary glass did not inhibit color development since it transmitted this region well. They found that apples were severely injured by an exposure twice daily over a nine-day period to the ultra-violet emitted by a mercury-vapor lamp (Alpine sun lamp) and concluded that, contrary to Magness' observations, the ultra-violet did not induce color formation. Arthur (1) studied the development of pigment in McIntosh apples under various light sources and at various temperatures. Arc lamps and a special incandescent filament lamp having a high ultra-violet output were found effective in developing color on apples when these were held at an air temperature of 2°C . After a continuous exposure to any of these light sources for a five-day period the fruits developed necrotic areas on the side exposed. It was shown that this injury could be produced by infra-red alone. This has been discussed in greater detail in another section of this work (Arthur, Paper XXV). Using glass and dyed cellophane filters the most effective region for producing pigment was found to be the visible blue-violet and the ultra-violet of sunlight which is not transmitted by ordinary window glass, that is, the region between $\lambda 3130$ and 2900 \AA . The ultra-violet of wave-length shorter than 2900 \AA , emitted by a mercury-vapor arc in quartz, injured the epidermal cells in a 30-min. exposure so that no pigment was formed when exposed subsequently to sunlight. The ideal light source for developing color on apples was found to be one which had considerable energy in the blue-violet and ultra-violet regions to the limit for sunlight, that is, to $\lambda 2900 \text{ \AA}$. Energy in the red and infra-red was not only unnecessary but injurious to the fruit. The source nearest this ideal which has been found to date is the 50-in. mercury-vapor arc in Uviol glass placed at a distance of about 16 in. from the fruit and used in conjunction with a Corex D filter to decrease the ultra-violet output of wave-length shorter than 2900 \AA . The best air temperature was found to be 15°C . Apples colored at a much slower rate or not at all at 3°C . and at 20°C . When placed under the lamp in the manner described, the internal temperature of the apples was found to be 21°C . Other light sources having a greater output of energy would result in greater internal heating and would no doubt require a much lower air temperature for the maximum rate of pigment formation.

The rate of pigment production was greatest on fruit picked green on August 25. This fruit was well colored after 40 hr. exposure. The rate of color production fell off from August 25 in fruit either picked or left upon the tree. The green peel, when removed from apples and floated

upon water exposed to the lamp, colored at about the same rate as when left intact. When the peel was heated or placed in alcohol or otherwise treated so as to kill or injure the cells, no color developed. It was believed that fruit did not color after a period in storage because of the death of the cells in the epidermal layers, since most of these cells which normally produce pigment were found dead when examined on November 8, after a period in cold storage. Both plasmolysis and reaction to vital stains were used to determine vitality. The extreme ultra-violet region beyond the limit for sunlight has been shown to be lethal to the cells of plant leaves by Arthur and Newell (2) and by many other workers. The intensity of this action increases rapidly with decreasing wave-length. The failure of this extreme region to induce pigment formation is no doubt due to the injurious effect upon the cells.

It should be noted that the pigment formed in the apple is extremely localized and restricted to only those cells which are exposed to light. When a piece of clear cellophane is shellacked at the edges and stuck to a green apple placed under the lamp, any mark drawn upon the cellophane with India ink will protect those cells under the mark from pigment formation. These cells so protected will remain green while the red color develops over the remaining unprotected surface exposed to the lamp. This principle has been used as a method of trade-marking or labeling apples. Aubin (4) has also employed it in printing photographic negatives on apples, using sunlight as a source. A preliminary study by Arthur seems to indicate that not all red pigments produced in fruits remain localized in the cells which produce them. Green cranberry and Abundance plum fruits were found to produce pigment under the same conditions as the apple when exposed to the mercury-vapor arc. When narrow strips of gummed paper labels are pasted on such fruit during the exposure, the cells under the paper slowly take on a faint pink color as the cells around the label, which are not protected, redden to the normal color. It may be considered in this case that there was a diffusion of pigment from the cells in which it was formed into neighboring (non-illuminated) cells where no pigment would otherwise form. This apparent migration, as has been pointed out, did not occur in the apple. Red pigment also formed in darkness in both the cranberry and Abundance plum but at a much slower rate than under the lamp. This was not true of the apple. There is also the possibility that the pigment itself does not migrate but rather that a reaction, which normally proceeds at a slow rate in darkness, is accelerated indirectly by the action of light on the neighboring cells. Blinks (6) has shown that a migration of pigment takes place within the cell during the flow of an electric current through plant tissue. In one group of plants the pigment migrated toward the positive or anode pole of the cell. The direction he found could be reversed by immersing the tissue in acid solutions. In another

group of plants he found a normal cathodal migration without any further treatment of the tissue, while in a third group there was no migration. While the work of Blinks does not prove, or even indicate, that there is a migration of pigment from cell to cell it demonstrates that pigments, under certain conditions, can be moved comparatively rapidly within the cells.

A continued, intensive study of the development of pigment in such isolated plant organs, held under constant environmental conditions, offers considerable promise of a very rapid advancement of our knowledge on the formation of pigment in plants, as well as the effect of external factors on such formation. This has been pointed out before by Mirande (21) in a discussion of his work with the scales from lily bulbs, but so far it has failed to stimulate any great amount of work in the field. The problem in such cases is reduced to its simplest form, that is, production of a pigment in an isolated plant organ induced by light and other external factors, where the process is not accompanied by the photosynthesis of other carbohydrate materials.

ABSORPTION AND TRANSMISSION OF ANTHOCYANIN PIGMENTS

There is general agreement among various investigators that the blue-violet and often the ultra-violet regions of sunlight are especially effective in anthocyanin production. It is also interesting to recall that many of the anthocyanins have absorption bands in these general regions. Schou (30) studied the absorption bands of several purified anthocyanidins, the colored constituents of the anthocyanin molecules. Many of these had absorption bands in the ultra-violet near $\lambda 2700 \text{ \AA}$. The maximum-absorption regions for one of these, pelargonidin, was found to be at the following wave-lengths: 2670, 3310, 4000, 4540, and 5040 \AA . Most of the other anthocyanidins studied were found to have primary bands near wave-lengths 5000 to 5200 \AA . Schou observed that the position of the OH groups caused shifts in the positions of the bands. Murakami, Robertson, and Robinson (23) found the region of absorption of both natural and synthetic chrysanthemum chlorides to be between wave-lengths 4800 and 5700 \AA . Arthur (1) observed that both the red peel and extracted red pigment of apples had an absorption band in this same general region. The green peel was found to have a transmission five to seven times as great as the red peel in both the ultra-violet and visible regions. The formation of the pigment in the epidermis acts, therefore, as a protective covering as regards the penetration of light into deeper layers of cells.

CONCLUSION

It should be stated that the exact mechanism of anthocyanin formation in living cells brought about by light, low temperature, and other factors, yet remains unknown. Even the effect of these factors on the

formation of pigment is in many cases not clearly understood. In some isolated plant organs such as the apple and lily-bulb scales the formation of pigment has been shown to depend upon light of a certain quality. In the McIntosh apple this formation is further known to depend upon a low temperature. From recent contributions to our knowledge of the constitution and synthesis of anthocyanin pigments, it is evident that these are a series of compounds and not a single substance. It is, therefore, unlikely that the same spectral regions will be found effective in this formation among different plant species. It is certain that the same external conditions do not induce pigment formation in all species, as some tissues form pigment in darkness, others only in light, while still other tissues never form pigment under any conditions. No generalization can be made that the formation of pigment in plants is related to the accumulation of carbohydrates in tissues. While such an accumulation may be associated with pigment production in a few cases, there is no evidence to show that this is invariably the case or even generally true. It is believed that more progress will be made in studies under carefully controlled environmental conditions of either whole plants or separate living organs from plants which form pigment.

REFERENCES

1. ARTHUR, JOHN M. Red pigment production in apples by means of artificial light sources. *Contrib. Boyce Thompson Inst.* **4**: 1-18. 1932.
2. ARTHUR, JOHN M., and J. M. NEWELL. The killing of plant tissue and the inactivation of tobacco mosaic virus by ultra-violet radiation. *Amer. Jour. Bot.* **16**: 338-353. 1929. (*Also in Contrib. Boyce Thompson Inst.* **2**: 143-158. 1929.)
3. ASKENASY, E. Ueber den Einfluss des Lichtes auf die Farbe der Blüten. *Bot. Zeitg.* **34**: 1-7, 27-31. 1876.
4. AUBIN, LOUIS. Vignettes et photographies sur fruits. *Revue Hort.* **103**: 471-474. 1931.
5. BEULAYGUE, L. Influence de l'obscurité sur le développement des fleurs. *Compt. Rend. Acad. Sci. [Paris]* **132**: 720-722. 1901.
6. BLINKS, L. R. Migration of anthocyan pigment in plant cells during the flow of electric current, and reversal by acids and alkalies. *Proc. Soc. Exp. Biol. and Med.* **29**: 1186-1188. 1932.
7. BONNIER, GASTON. De la variation avec l'altitude des matières colorés des fleurs chez une même espèce végétale. *Bull. Soc. Bot. France* **27**: 103-105. 1880. (*See also Ibid.* **35**: 436-439. 1888.)
8. BOYLE, R. Experiments and considerations touching colours. London, 1664.
9. COMBES, R. Émigration des substances azotées des feuilles vers les tiges et les racines des arbres au cours, du jaunissement automnal. *Rev. Gén. Bot.* **38**: 430-448, 510-517, 565-579, 632-645, 673-686. 1926.
10. COMBES, R., and D. KOHLER. Ce que deviennent les hydrates de carbone quand meurent les feuilles des arbres. *Compt. Rend. Acad. Sci. [Paris]* **175**: 590-592. 1922.
11. DENNY, F. E. Changes in leaves during the period preceding frost. *Contrib. Boyce Thompson Inst.* **5**: 297-312. 1933.
12. EMERSON, R. A. The genetic relations of plant colors in maize. New York [Cornell] *Agric. Exp. Sta. Mem.* **39**. 1921.

13. FLETCHER, L. A. A preliminary study of the factors affecting red color on apples. Proc. Amer. Soc. Hort. Sci. **26**: 191-196. 1929.
14. GERTZ, O. Studier öfver anthocyan. Akademisk Afhandling. 410 p. Håkan Ohlssons Boktryckeri; Lund, 1906.
15. HECKEL, E. Sur l'intensité du coloris et les dimensions considérables des fleurs aux hautes altitudes. Bull. Soc. Bot. France **30**: 144-154. 1883.
16. KARRER, P., and A. HELFENSTEIN. Plant Pigments. Ann. Review Biochem. Stanford Univ. Press **1**: 551-580. 1932. (*See also* Ibid. **2**: 397-418. 1933.)
17. KLEBS, G. Ueber Variationen der Blüten. Jahrb. Wiss. Bot. **42**: 155-320. 1906.
18. KOSAKA, H. Ueber den Einfluss des Lichtes, der Temperatur und des Wassermangels auf die Färbung der Chrysanthemum-Blüten. Botan. Mag. **46**: 551-560. 1932.
19. LINSBAUER, L. Ueber photochemische Induktion bei der Anthokyanbildung. Wiesner-Festschrift. pp. 421-436. Verlag Karl Konegam; Wien, 1908.
20. MAGNESS, J. R. Observations on color development in apples. Proc. Amer. Soc. Hort. Sci. **25**: 289-292. 1928.
21. MIRANDE, MARCEL. Sur la formation d'anthocyanine sans l'influence de la lumière dans les écailles des bulbes de certains lis. Compt. Rend. Acad. Sci. [Paris] **175**: 429-430. 1922. (*See also* Ibid. **175**: 496-498. 1922.)
22. MÖBIUS, M. Die Farbstoffe der Pflanzen. Gebrüder Borntraeger; Berlin, 1927. (Handbuch der Pflanzenanatomie; hrsg. K. Linsbauer, Abt. I, T. 1. (Lfg. 20) V. 3.)
23. MURAKAMI, S., A. ROBERTSON, and ROBINSON. Experiments on the synthesis of anthocyanins. Part VI. A synthesis of chrysanthemum chloride. Jour. Chem. Soc. **1931**: 2665-2671.
24. MURNEEK, A. E., and J. C. LOGAN. Autumnal migration of nitrogen and carbohydrates in the apple tree with special reference to leaves. Missouri Agric. Exp. Sta. Res. Bull. 171. 30 p. 1932.
25. ONSLOW, MURIEL WHELDAL. The anthocyanin pigments of plants. 2nd ed. 314 p. Univ. Press; Cambridge, 1925.
26. OVERTON, E. Beobachtungen und Versuche über das Auftreten von rothem Zellsaft bei Pflanzen. Jahrb. Wiss. Bot. **33**: 171-231. 1899.
27. PEARCE, G. W., and L. R. STREETER. A report on the effect of light on pigment formation in apples. Jour. Biol. Chem. **92**: 743-749. 1931.
28. SACHS, JULIUS. Ueber den Einfluss des Tageslichtes auf Neubildung und Entfaltung verschiedener Pflanzenorgane. Beilage Bot. Zeitg. 1863.
29. SANDO, C. E. Autumnal coloring. Indus. and Eng. Chem. News Ed. **9**: 338. 1931.
30. SCHOU, SVEND AAGE. Über die Lichtabsorption einiger Anthocyanidine. Helvetica Chim. Acta **10**: 907-915. 1927.
31. SCHRADER, A. L., and P. C. MARTH. Light intensity as a factor in the development of apple color and size. Proc. Amer. Soc. Hort. Sci. **28**: 552-555. 1931.
32. SENEBIER, J. Physiologie végétale. Geneva, 1799.
33. SORBY, H. C. On comparative vegetable chromatology. Proc. Roy. Soc. [London] **22**: 442-483. 1873.
34. WILLSTÄTTER, R. Untersuchungen über die Anthocyanine. I, II-X. Ann. Chem. (Liebig's) **401**: 189-232. 1913; **408**: 1-162. 1915.
35. WILLSTÄTTER, R., and H. MALLISON. Über Variationen der Blütenfarben. Ann. Chem. (Liebig's) **408**: 147-162. 1915.
36. WILLSTÄTTER, R. M., und A. STOLL. Untersuchungen über Chlorophyll; Methoden und Ergebnisse. 424 pp. Julius Springer; Berlin, 1913.

XXXVI

EFFECTS OF RADIATION ON BACTERIA

B. M. DUGGAR

University of Wisconsin, Madison

Sunlight. Ultra-violet radiation. Visible light. Influence of conditions on the effectiveness of radiation. Absorption of radiant energy. Relative sensitivity. X-ray radiation. Miscellaneous considerations. References.

Quantitative investigations on the influence of radiation on bacteria are relatively recent, though it would probably be unfortunate to name a paper or date that might be regarded as a starting point for this type of study. This difficulty is causally related to the fact that acceptable accuracy in such studies involves so many factors of both biological and physicochemical nature that no one investigator could at once rise above the imperfections of technique as pertaining broadly to material, environment, or apparatus and thus be placed beyond criticism in the light of later developments. The history of this field of work is, therefore, not unlike that of many other fields in the fact that development has been largely gradual, dependent upon advances in the basic sciences and upon increasing knowledge of the behavior of organisms. At the outset, however, recognition should be accorded the growing importance of microorganisms, especially bacteria, as objects of study in fundamental investigations in which ordinarily control of environment, purification of the material, purity of stock, magnitude of population, practical limitations in size and cost of apparatus, and comparative ease in securing results statistically accurate are all among the essential factors.

Observations on bacterial response to radiation extend back to 1877. It would seem to be of interest and of importance to refer to some of the developments resulting from the earlier studies as well as from the later, but the extent of the literature renders a complete account impracticable. An overwhelming majority of the papers deals with the bactericidal or lethal effects. However, the bacteria also lend themselves for experimental work on the influence of radiation on "stimulation," respiration, products of metabolism, and many other physiological processes. Practical lines of work have developed in the direction of sanitation and disinfection or sterilization. Available review articles on the effects of radiation on bacteria are of limited scope. Among the helpful summaries are the following: Bic (16), Busck (24), Duclaux (41), Ehrismann and Noethling (45), Furniss (52), Hausmann (72), Janowski (81),

Laurens (95), Pincussen (120), Raum (126), Reichel (127), Weinstein (157), Wiesner (160), and Winterstein (162).

SUNLIGHT

It is generally granted that the observations of Downes and Blount (35), published in 1877, constitute the real "discovery" of the killing action of light on bacteria and other microorganisms, thus drawing the attention of biologists to the significance of the chemically active spectral radiation. They showed primarily that certain organic products in solution, undergoing decomposition and decay by the action of a mixture of bacteria, would be inhibited in this decomposition by long exposure to direct sunlight. Fresh extracts thus exposed were largely prevented from the usual course of decomposition. They recognized the importance of determining the regions of the spectrum involved and the need of intensive study of this effect. There followed almost immediately numerous qualitative observations of interest, mostly with liquid cultures, all serving to indicate that the lethal effects of sunlight were not limited to a few sensitive organisms, and that there was a definite need of recognizing in sunlight a "new" factor in the environment of microorganisms. The sanitation aspect and the "natural purification" of the water of rivers were practical applications stimulating investigation.

Leading students of bacteriology took the time to invade this field of observation, bringing to bear upon it improved bacteriological technique. In several short papers Duclaux (39, 41) reported killing effects even upon spores (cf., also, Straus, 145), and he observed some diversity in the resistance to light of the several organisms studied. From a practical standpoint he regarded light as a universal disinfectant. The work of Arloing (4, 5) on the anthrax bacillus was confirmatory of the earlier studies, and he was particularly struck by the fact that anthrax spores, known to be highly resistant to high temperature, are easily destroyed by sunlight as well as by light from certain artificial sources. He ascribed bactericidal action to the entire sun spectrum. Roux (133) concluded that oxygen might be a factor in the lethal action of sunlight, a consideration frequently revived in some of the later work. Tizzoni and Cattani (149) demonstrated the lethal effect of sunlight on the vegetative cells and spores of the tetanus bacillus.

Since many of the experiments made at this time were on animal or human parasitic organisms, and since all such organisms were found sensitive to light, overemphasis was placed on the idea that parasitic organisms exhibited a unique relation to this factor of the environment. Extravagant claims were made regarding the disinfecting value of even diffuse light of low intensity, and such extreme views were not overcome for a period of years. On the other hand, some very careful experimental work was done, and in this connection reference should be made to a

series of papers by Ward (155, 156) beginning in 1892. At this time there was very little careful work on the efficiency of the different spectral regions (cf. Arloing, 4, 5; Janowski, 81; and others). Ward's studies eventually included the effects of radiation from the carbon arc, but his earlier experiments were made with sunlight and the solar spectrum. Having obtained what seemed convincing evidence, on plate cultures with gelatin, that the spores of *Bacillus anthracis* are killed by the direct action of sunlight and not by increased temperature, likewise that a reasonable time exposure did not spoil the substrate as a food source, he proceeded to do more critical work on light quality. Using both glass and solution filters, spectroscopically tested, he found no inhibition of growth behind screens transmitting red, orange, and yellow. Bactericidal action was marked behind screens transmitting most or all of the blue-violet, whether other wave-lengths were present or were excluded. In view of the doubt still existing in respect to lethal action of ultra-violet radiation longer than about $\lambda 3100 \text{ \AA}$, it should be noted that with his unmeasured intensities lethal action through the ordinary glass of a Petri plate was definite in the blue, blue-violet, and beyond. Even though the intensities in these ranges may have been considerable, the results are not easily explained.

Ward's best technique, like that of Buchner (20), was to distribute the bacteria in the melted agar, pour the plate, and subsequently expose the closed dish covered with black paper except for a test circle or stenciled letter. Colony growth served to indicate the extent of the lethal effect. In his later experiments quartz windows were introduced, the spectrum was "photographed" on the plate through the relative abundance of the colonies appearing, and with an uncovered electric arc light the ultra-violet region was found particularly effective as a lethal agent.

During the earlier periods of these sunlight studies, as also of light from artificial sources, no attention was paid to the measurement of light intensities. In view of this circumstance, and further, since so many well known factors involving time, place, climate, and local atmospheric conditions influence intensity (cf. Brackett, Paper IV of this book), no particular interest attaches to the details of these earlier or of later qualitative experiments aside from the part they have played in the development of this subject.

ULTRA-VIOLET

Earlier Studies.—Notable impetus was given to heliotherapy and to investigations dealing with the effects of radiation, especially of ultra-violet, by the establishment at Copenhagen in 1896 of the Finsen Institute (Finsens Medicinske Lysinstitut). The establishment of this institute is to be attributed to the recognition of the work of Niels R. Finsen in

the application of light to the treatment of disease. As previously indicated, even prior to the time when definite wave-lengths of light were isolated for the purpose of determining accurately their biological effects, it had become apparent that ultra-violet was an important factor if not a chief factor, in the reported lethal effects of sunlight, and of light from artificial sources as well, on microorganisms. Arsonval (6), Ward (155, 156), and others eventually arrived at this conclusion during the progress of their work. Strebel (146) isolated regions of the spectrum, using cadmium and aluminum spark sources, and showed that strong killing action for bacteria was confined to the ultra-violet. The region of lethal action, so far as studied, was determined by Barnard and Morgan (9) to lie between $\lambda 3287$ and 2265 \AA . Although, in the literature, the lower wave-length limit of bactericidal action may be thus definitely stated, little consideration should be given to this below 2400 or 2300 \AA in the absence of intensity measurements, owing to the increasing absorption in the instrument, apparatus, and materials.

As a result of his earlier investigations, Bie (16) had regarded all wave-lengths (infra-red effects were not studied) as inactivating, but shorter wave-lengths were more effective. Subsequently he computed the lethal effects of $\lambda 2950$ to 2000 \AA to be at least 10 or 12 times more effective than the longer wave-lengths tested, and he may be regarded as having clearly established the dominant action of ultra-violet. These results were obtained with a carbon arc, a quartz monochromator, and the bacteria exposed in a small moist chamber covered with a quartz window. At about the same time, Bang (8), working with *B. prodigiosus*, reported that in the ultra-violet there exist two bactericidal maxima; first in the region of $\lambda 3600$ to 3400 \AA and then a second maximum rising sharply at about 3000 \AA to a higher value and continuing horizontally toward 2000 \AA . Later (8b) he placed the highest lethal action, for wave-lengths shorter than 3000 \AA , at around $\lambda 2500 \text{ \AA}$. An explanation of his results in the region of the longer ultra-violet remains unconfirmed. The maximum at 2500 \AA has been regarded (Mme. and M. Henri, 73) as indicating greater intensity in that part of the ultra-violet.

The determination of incident energies in the different spectral regions as applied to biological studies was the advance made by Hertel (75). With a quartz prism and quartz lenses he utilized the spectrum from spark gaps of several metals. Intensity measurements were made with a thermopile and galvanometer. His results were definite in determining that bactericidal action was directly related to energy furnished and absorbed, and within limits inversely related to wave-length. However, he gives data for only six spectral lines, between $\lambda 4400$ and 2100 \AA . It seems rather remarkable that following this work there appear to be no other studies on bacteria in which intensities were measured for a period of years.

Thiele and Wolf (148) used cooled bouillon suspensions of several species of bacteria for irradiation, and they also stirred the suspension during irradiation. None of the organisms tested was resistant to ultra-violet below 3000 Å. Newcomer (108), using a fresh-water suspension of the typhoid bacillus and working under conditions essentially quantitative, found practically zero efficiency of radiation at 2970 Å, while the maximum effect occurred at 2800 to 2100 Å. Henri and Moycho (74) found the most effective region for bactericidal action to be around 2800 Å, and they indicated the amount of energy required to kill at 0.002×10^7 erg/cm². Irradiation for even 10 hr. at 3300 Å produced no effect. General confirmation of the restricted effective region may be seen in the work of Eidinow (46, 47) and many others. In order to obviate the possibility that the irradiation of the organic medium might indirectly affect the results, Newcomer (108) used fresh-water suspensions of typhoid bacilli in capillary quartz tubes held in the spectrum of a quartz spectrograph. With sparks of several metals as sources of radiation, no killing was obtained for wave-lengths longer than 3000 Å.

Improving somewhat upon an earlier (Ward, 155) method of determining lethal effects by throwing the spectrum of the source on an agar plate sown to bacteria, Browning and Russ (19) exposed the agar plate painted with bacteria (following Bang, 8) in a holder in a quartz spectrograph. No attempt was made to determine intensities. Clear lines, coinciding with the emission lines, were found on the plate between 2940 and 2380 Å. Accordingly, they placed the effective region below 3000 Å. Independent work along similar lines was done by Mashimo (100), who used the spectrum of the iron spark and tested the response of seven species of bacteria. He also made no intensity measurements, and, accordingly, the data reflect both the intensity distribution of the source and the sensitivity to wave-length. The data are, however, consistent in showing the effective wave-lengths as beginning at about 2950 Å and extending, in some cases, toward the beginning of atmospheric absorption, *i.e.*, somewhat below 1900 Å. There was high efficiency in the general region ca. 2300 to 2750 Å.

Mme. Henri (73), working with a filter system, reported that ultra-violet efficiency increases down to 2144 Å, and as a result of further work it was concluded that the abiotic action is continually augmented as wave-length diminishes.

Careful work on wave-length limits for lethal action was done by Bayne-Jones and Van der Lingen (10), who worked with *Staphylococcus aureus*, *S. albus*, and *B. coli*. The bacteria were distributed on the surface of agar spread upon glass plates fitting the plate holder of a Hilger spectrograph, and thus exposed to the spectrum. Spark sources of radiation with various metals as terminals were employed, and, accord-

ingly, the incident light intensities in the regions of the spectrum on the plate were different. With incubation of the plates, the extent of colony development gave a picture of the influence of the various wave-lengths. Under such conditions killing occurred in the ultra-violet, but $\lambda 2960 \text{ \AA}$ was the longest wave-length lethal for these organisms, and even at that wave-length an exposure of 1 hr. or more was required. Questioning this wave-length limit, they proceeded to use sunlight as a direct source, merely interposing glass screens of determined absorption (using a Watkins actinometer) between the incident light and the exposure vessel. With such an arrangement it was clear that at 3500 \AA killing occurred in 3 hr., whereas with a blue filter transmitting $\lambda 5200$ to 3600 \AA , no killing occurred in 6 hr.

Recent Work.—A very careful radiometric study of the effects of ultra-violet on *B. coli* was made by Coblenz and Fulton (29). They used a quartz-mercury-vapor lamp. The several broad wave-length regions investigated were defined by means of glass screens of differing transmission qualities and by mica screens of different thicknesses. Absolute intensity values were obtained by the use of a thermopile and galvanometer, exposure to the radiation source, and reference to a standard of radiation affording a basis of computation of the experimental intensities. Their work was facilitated by the use of the mica screens referred to, having an absorption band with a maximum at 2600 \AA , so that variations in transmission were obtained with the different thicknesses.

From their data it appeared that the effective spectral range varied from about 3650 \AA to the shortest used, *i.e.*, in the range of the Schumann region, and it was concluded that the shortest wave-lengths have the most violent lethal action. In the limiting region of longer ultra-violet, killing occurred under effective screens when the intensities were adequate, and they believed that this intensity explains the bactericidal action of sunlight. With this source, wave-lengths less than 2800 \AA are estimated to be at least 10 times more rapid in killing action than wave-lengths greater than 3050 \AA , in spite of the intensity differences in favor of the latter. It appeared also from their results that continuous and intermittent exposures were equally effective, so that intermittent irradiation of the organism does not induce a latent effect, during the intervals of rest, "either in stimulating growth or in continuing the lethal action." At low intensities killing action is greatly retarded relatively, *i.e.*, at $I/50$ the killing ratio of the standard to low intensity is 50:70 to 50:80. The energy value of the most active germicidal radiation from the mercury arc is defined as follows: "Assuming that all the radiation wave-lengths $170 \text{ m}\mu$ to $280 \text{ m}\mu$ are intercepted, conserved, and utilized in lethal action, then the total energy required to kill a bacterium amounts to . . . 19×10^{-12} watt or 4.5×10^{-12} gm. cal."

The contribution made by Gates (59) to the effects of monochromatic radiation on bacteria involved nothing new in the way of apparatus or procedure, but rather a selection of efficient and practicable methods by means of which consistent quantitative results were obtained. A large quartz-monochromator and quartz-lens system was used for the separation and focusing of the specific wave-lengths required, a thermopile and galvanometer for energy measurement, and a quartz-mercury-vapor lamp as a source of radiation. The work was done primarily with *Staphylococcus aureus*, the bacteria for exposure being washed over a hardened agar surface; and after exposure the surface was covered with a thin layer of agar, with the idea of reducing colony spread and promoting accuracy of colony counting.

The wave-lengths chosen were wholly in the ultra-violet, chiefly 2378 to 3126 Å. At all wave-lengths studied the reactions of this organism followed essentially similar curves, each at a different energy level. At $\lambda 2600$ to 2700 Å the incident energy (see Fig. 1) required to kill is less than in any other region of the spectrum examined.

The data suggest a second maximum effect below $\lambda 2300$ Å. Using 50 per cent survival as a basis, the amount of energy required to kill was 88 erg/mm.² at 2675 Å, 3150 erg/mm.² at 3020 Å, and 25,000 erg/mm.² at 3126 Å. The curves exhibiting the reactions of *S. aureus* show a general similarity to those for monomolecular reactions, but with some evidence of the effect of age and metabolic activity on the form of the curve, the author concludes that "the typical curve seems to be best interpreted as one of probability."

A well-rounded discussion of the lethal action of ultra-violet on bacteria has been presented by Ehrismann and Noethling (45), but it is not possible to compare very accurately the values obtained by these authors with those of Gates (59), since the former authors give the lethal effects only in terms of 1 to 10 per cent and 90 to 100 per cent killing, respectively. The procedure employed seems to have been the best available, and the techniques have been well chosen. The apparatus set-up included a double monochromator with quartz optics, a *K* photocell, and a bolometer. The agar-plate, surface-exposure method was employed in some phases of the work. The authors used one species

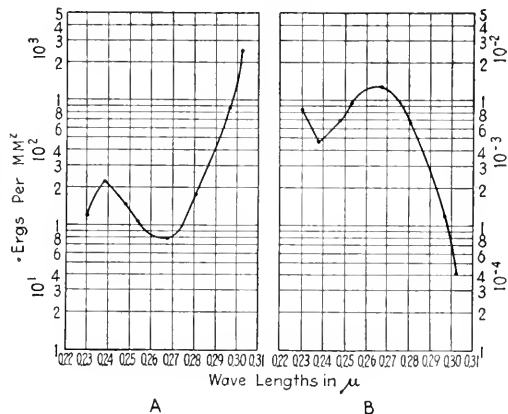

FIG. 1.—A, curve of incident energies involved in the destruction of 50 per cent of *B. coli*; B, curve of the reciprocals of A. (From Gates, 60.)

of yeast and the following bacteria: *B. coli*, *B. prodigiosus*, *B. pyocyaneus*, *Micrococcus candidans*, *Staphylococcus pyogenes aureus*, and *Vibrio Finkler*. The highest sensitivity for five of the organisms occurred at approximately $\lambda 2650 \text{ \AA}$, while for *B. coli* the maximum was at $\lambda 2510 \text{ \AA}$, and for *B. prodigiosus*, $\lambda 2801 \text{ \AA}$. For the six bacteria the energy required for 1 to 10 per cent killing at $\lambda 2650 \text{ \AA}$ ranged from 2900 to 5970 erg/cm.² (or 29 to 60 erg/mm.²), whereas Gates obtained for *Staphylococcus aureus* ca. 88 erg/mm.² for 50 per cent survival, which is to be contrasted with Wyckoff's (166) values of 110 erg/mm.² for *Staphylococcus aureus* at 2696 \AA . The value obtained by Ehrismann and Noethling at 90 to 100 per cent killing for *B. coli* is 174 erg/mm.² It is further interesting to note that at $\lambda 3130 \text{ \AA}$, Ehrismann and Noethling find that 1 to 10 per cent killing does not occur with an energy value of 3.7×10^6 erg/cm.², while at $\lambda 3030 \text{ \AA}$ the value for *B. coli* is 590,000 erg/cm.², or 5900 erg/mm.² This last value may be compared again with the result obtained by Wyckoff at 3132 \AA where 5200 erg/mm.² represents energy requirement for 50 per cent killing.

The experiments of Wyckoff (166) add some quantitative data for *B. coli* and a few measurements for *B. aertrycke*. The survival ratios are presented for wave-lengths 3132, 2900, 2803, 2699, 2652, and 2536 \AA , and these can be represented by straight lines plotted on semilogarithmic paper. The effective energies are given as those required to kill approximately one-half the bacteria irradiated. The energies involved in bactericidal action were determined for each wave-length. Using the absorption data of Gates, he found the highest efficiency in the ultra-violet at $\lambda 2652 \text{ \AA}$. Comparing the results obtained in the ultra-violet with his earlier series on X-rays, later cited, Wyckoff shows that the energy required for killing in the ultra-violet is about 100 times greater than that required for the same killing in the X-ray region. Wyckoff's analysis of the data for $\lambda 2699 \text{ \AA}$ indicates that of the quanta absorbed, only one in about four million is capable of causing the death of the cell, and this might be supposed to occur within a sensitive volume about the size of a protein molecule (see section of this paper on X-rays). Unfortunately, it would seem, the author disregards the importance of effects which do not result in killing.

The use of ultra-violet radiation for the elimination of bacteria in drinking water has received considerable attention on the part of those concerned with the water supplies of cities, but apparently the adoption of this as a practical procedure has been limited to a few French cities. On the side of the more fundamental studies, as well as on that of the applications, there is an extensive literature (cf. Schwarz and Aumann, 138; Schroeter, 137, and others). More general use has been made of ultra-violet in the partial sterilization of water of swimming pools.

VISIBLE LIGHT

From the discussion thus far, it would no doubt be confusing to attempt to draw any general conclusion regarding the effect on bacteria of light within the visible spectrum. Speaking generally, most of the earlier observers, using sunlight and filter systems, were confident of the demonstration of lethal action (4, 5, 16, 155). With the utilization of artificial sources of radiation and the greater application in biological work of the quartz spectrograph and quartz monochromator, attention centered upon the more intensive lethal effects in the ultra-violet. In fact, with the safer establishment of the rule of the inverse relation of killing to wave-length, within limits, and with the difficulty of obtaining sufficiently high intensities at the longer wave-lengths in time intervals sufficiently short to avoid multiplication by growth, the quantitative studies have given only secondary attention to the visible region, or even to the longer ultra-violet. Moreover, with very high energy levels, an insignificant percentage of ultra-violet below $\lambda 3000 \text{ \AA}$ might afford the necessary intensity in the more actively lethal region to account for any effects observed. Increased purity, by means of a double monochromator, is secured at the expense of intensity. In considering the earlier work, where relatively intense sunlight was employed, the more recent data with artificial sources presented by Bayne-Jones and Van der Lingen (10), Coblentz and Fulton (29), and Duggar and Hollaender (42) are suggestive of the possibility that further quantitative studies in the visible spectrum may give evidence of lethal effects, or at least of other physiological effects of fundamental interest. In this connection it should be noted that absorption of radiation in the visible does occur (see section of this paper on absorption). Further, in studies on the effects of visible light, there should be included an adequate consideration of the possible influence of oxygen, high temperature, and other environmental conditions.

INFLUENCE OF CONDITIONS ON THE EFFECTIVENESS OF RADIATION

Temperature.—That bactericidal effects are independent of temperature was reported by Cernovodeanu and Henri (25), but it is not clear that their technique would have detected differences of the order characteristic of photochemical or physical processes. In the light of the fact just mentioned, Henri's conclusion that no change occurred in the speed of reaction between 0° and 55°C . should be regarded as tentative. On the other hand, Becquerel (12) reported bactericidal action with anthrax spores in 2 to 3 min. at room temperature, whereas at the temperature of liquid air an exposure of 6 hr. was required for equivalent action. Unfortunately, the conditions do not appear to be adequately stated. The suggestion may be made, however, that at temperatures below freezing, it is logical to assume dehydration of the protoplast, and since low water

content affects the resistance of many organisms to temperature, it may also affect the resistance to radiation.

Bang (8) found that bacteria which are killed at an average of 30 sec. at 45°C. require an average of 50 sec. when the temperature is reduced to 30°C. Many other data are included, the absolute values of which do not necessarily agree with the above, but the relation of the higher to the lower temperature is of about the order indicated. Thiele and Wolf (148) reported no killing effect on *B. coli* when the light from a carbon arc was screened by glass and when the culture was cooled during exposure. However, when the temperature was raised to 40°C. a similar exposure resulted in killing. They assumed a significant influence of temperature within the range of visible light. Wiesner (160) also regarded high temperature as important in extending bactericidal action to longer wave-lengths. The work of Hill and Eidinow (76) afford results that are quite discordant. Using both the carbon arc and the mercury-vapor lamp as sources of radiation, they report that at constant distance the lethal time is inversely proportional to the temperature, arriving at the formula $T \times \sqrt{t} = K$, where T = temperature in °C., and t = time in minutes. Both excessive heat and excessive cold lowered resistance to ultra-violet.

Using an agar film with the medium at pH 7.4, and with the spectrographic method of exposure (p. 1123), Bayne-Jones and Van der Lingen (10) were able to demonstrate that while bactericidal action is not wholly independent of temperature, the temperature coefficient of this reaction is very low. For the temperature range 2 to 12° and 30 to 40°C. the temperature coefficients (Q_{10}) were respectively 1.06 and 1.04, for complete killing. Likewise, for 100 per cent killing Gates (59) confirms the validity of the result just stated, finding a temperature coefficient of 1.06. At progressively lower survival percentages he finds a slight increase in this coefficient, the average for the course of the reaction being approximately 1.1. It would appear that the influence of a certain range of temperature on the effects of ultra-violet radiation may agree well with the expectation on the basis of a simple photochemical reaction, but there is the further suggestion that possibly complications enter the picture when considering visible light. Data on the influence of very low temperatures seem insufficient to warrant consideration at present.

Hydrogen Ion Concentration.—Tests were apparently first made by Bayne-Jones and Van der Lingen (10) to determine the possibility of altering either the velocity of the bactericidal effect or the wave-length limits by means of a graded series of reactions. Exposed by the agar-plate method in a spectrograph to radiation from the iron arc, it was found that the killing effect remained constant with respect to wave-length limits throughout the following range, pH 5.5, 6, 7.4, and 8. In

order to test the effect upon reaction velocity, suspensions of the bacteria (*Staphylococcus aureus*) were prepared in phosphate buffers over the range pH 2 to 9. Drops of the suspension on cover glasses were exposed at 25°C. to the zinc spark for measured periods of time and subsequently transferred to nutrient broth. Very slight change occurred in the time required to kill between pH 4.6 and 9. Below pH 4.6, the isoelectric point of the bacteria, the time to kill drops off suddenly, so that acceleration of the killing action is marked in the more acid media. This is interpreted to indicate that "the nature of the electric charge upon a living organism radiated by ultra-violet has a direct influence upon the destructive action of that radiation."

Gates (59), working also with *Staphylococcus aureus*, made determinations only within the range pH 4.5 and 7.5, and found no appreciable influence upon the bactericidal reaction.

Effects on the Medium.—Seeking an explanation of the lethal effect of light on organisms, many of the early workers were led by several circumstances, not primarily experimental, to attribute these effects to the result of oxidation. In the first place, there was current the view that, in general, the destruction of organic material results primarily through oxidative processes. It was also a relatively simple explanation to consider that the effect was indirect, induced through the action of light on the substrate or upon the water of the substrate. The view that oxygen is chiefly important in the killing effect seemed to be confirmed by the fact that stirring or shaking exposed fluids enhanced killing efficiency, whereas stirring or shaking in the case of exposed fluids is, of course, essential in order that all organisms may be brought more or less equally into the path of the beam of light. Again, the observation was made that organisms at the surface of a liquid were more readily killed, and this was thought to be connected with the oxygen supply. The low penetrability, at least of the ultra-violet, was not always recognized. However, a certain number of observations by early workers such as Ward (155), D'Arcy and Hardy (3), Dieudonné (32), and others seemed to confirm the general view that oxidation is important. On the other hand, experimental evidence against the view promptly accumulated. In particular, Bie (16) showed that strong bactericidal action of ultra-violet could be demonstrated in the absence of any free oxygen. Henri (73a) was definite, perhaps largely on theoretical grounds, in declaring that the effect of light is direct, that is, on the protoplasm and not through the formation of peroxide.

Thiele and Wolfe (148) gave special attention to this problem. They purified the gases bubbled through an exposure vessel until no trace of oxygen could be detected, so that they came to the conclusion that light action is wholly independent of the presence of oxygen. Likewise they determined that peroxide has no indirect influence on the process.

Meanwhile considerable evidence has gradually accumulated in support of the view that the presence of oxygen may influence the alleged destructive action of visible light, and likewise the effects of fluorescing substances on the bactericidal effect at visible wave-lengths. This evidence has come more particularly from the side of studies on the action of light on enzymes, toxins, and other products usually requiring high intensities in order to effect inactivation (cf. the discussions in Papers X and XXXVII of this work).

The view that irradiation of aqueous media with ultra-violet light may produce peroxide, and that the injurious effect should be attributed to this product, has also been strongly maintained by Bedford (13). He attempts to show that the destructive effect of radiation is proportional to the production of peroxide, and that relative susceptibility of the organisms to radiation is of the same order as their susceptibility to peroxide. Results of this type do not appear to be supported by the general evidence from the side of photochemistry (cf. Paper VII of this work).

Wholly aside from the influence of oxygen, or the production of peroxide in the media, is the question that has been raised frequently in the literature regarding the effect of visible or ultra-violet light on the medium or substrate in which the organisms are irradiated. A continuing influence through the substrate can apply, of course, only when the irradiated material becomes a part of the environment during the further growth of the irradiated organism, as in the case of irradiation on agar surfaces, but not with the usual procedure in suspension irradiation. The evidence from the practical experience of many indicates clearly that the irradiation of the usual bacteriological media with the dosages commonly employed induces no changes resulting in toxicity (cf. Ward, 155; Browning and Russ, 19; Mashimo, 100; Coblentz and Fulton, 29; Gates, 59, and many others).

In general, the evidence is further substantiated by the many data that have accumulated in regard to the high intensities required for the production of changes leading to toxicity in such products as the simple proteins and peptones, or in such complex media as milk. On the other hand, caution should be observed and controls invariably included in any series where high intensities are employed, since it is equally certain that changes are induced in proteinaceous and other media by intensities considerably greater than those needed for destruction of microorganisms.

ABSORPTION OF RADIANT ENERGY

Owing to the extent of studies on the lethal effect of ultra-violet radiation and the significance of energies in the ultra-violet in producing the bactericidal effect, absorption studies with bacteria have been concerned more particularly with the shorter wave-lengths of sunlight and

of artificial sources particularly rich in ultra-violet radiation. The rapid rise of the curve of lethal action as wave-length decreases, in general, from around 3000 Å toward the region of 2500 Å or lower, makes it also particularly important and interesting to know precisely the absorption values of the cells in this region of the spectrum.

In the earlier work on the absorption spectra of bacteria crude suspensions were employed, and, in consequence, the scattering effect introduced an error interfering materially with accurate determinations. In the work of Browning and Russ (19), a wide absorption band was found beginning at 2960 Å and extending over lower wave-lengths to 2100 Å. This band accordingly coincided rather accurately with the bactericidal range, and is of interest in spite of the fact that the concentration in bacterial cells is not stated. *B. typhosus* and *Staphylococcus pyogenes aureus* were the organisms used.

Working with three organisms, Bayne-Jones and Van der Lingen (10) used a highly concentrated suspension containing five billion organisms per cubic centimeter. With a quartz spectrograph and a zinc or an iron spark source, they made photographs at intervals, comparing these consistently with photographs of the emission spectra of the arcs employed, thus determining approximately the amount of light absorbed. The results with the several bacteria were practically identical. The effect of scattering was recognized, so that the results are regarded as relative. Up to 3000 Å the suspensions used completely absorbed the ultra-violet, while at 3500 Å absorption was still strong, and at 3700 Å the absorption was 50 per cent. Above 3900 Å the "emulsion transmits, but greatly diminishes" the radiation. It will be recalled that these authors (see section of this paper on ultra-violet) were able to demonstrate bactericidal action at wave-lengths somewhat longer than 3500 Å (with filters).

In connection with his work on lethal effects of ultra-violet on *B. coli*, it is interesting to note that Henri (73a), on the basis of the absorption spectrum of egg albumen, advanced the view that the bactericidal effect may be properly regarded as proportional to the coefficient of protoplasmic absorption.

Gates (60) varied the technique by scraping a mass of bacteria from an agar slant and pressing this into a layer between quartz plates to yield a film consisting primarily of bacterial cells and the accompanying metabolic products. He adopted as a standard unit of thickness 0.8μ , that is, the average diameter of *Staphylococcus aureus*, one of the organisms employed. It is assumed that the bacteria thus form a homogeneous medium and apparently that all are living. The original paper should be consulted for the technique both in the absorption studies and in the methods of determining the thickness of the bacterial film. Five series of determinations were made with *Staphylococcus aureus* and with *B. coli*.

Curves were obtained characteristic of biological fluids containing protein material. These curves present a general similarity to the reciprocals of the curves for bactericidal effect (Fig. 2). It is not regarded as significant that there are certain differences in the sets of curves referred to, since, while all the products of the cell will contribute to the total absorption, it is scarcely possible that absorption by all such products will be effective, that is, participate in the bactericidal effects. In general, this study reveals the existence of an absorption maximum between 2600 and 2700 Å, corresponding strikingly to the maximum bactericidal effect. A

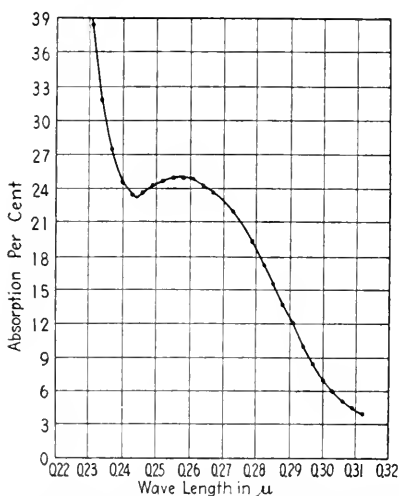

FIG. 2.—The coefficients of absorption of ultra-violet radiation by a layer of *B. coli* 0.8 μ in thickness. (From Gates, 60.)

second maximum seems to be approached below 2300 Å (Fig. 2). This work has been criticized (45) on the ground that the determinations were made with energy intensities sufficient to cause the death of the bacteria during the interval of exposure, so that the absorption curves given would actually represent the absorption by dead bacteria.

Various students of lethal effects have directed attention to the probability that the energy resulting in killing is absorbed by a comparatively small part of the cell organization, and this is independent of any "specific sensitive volume," as often discussed elsewhere in the literature. It would seem to be clear, therefore, that no absorption curve found could approach an accurate picture of a theoretical absorption spectrum of the essential material or materials.

Ehrismann and Noethling (45) discuss at some length the difficulties and the sources of error in any final determination of absorption values that actually represent effective absorption, that is, absorption by those cell constituents that may lead directly or indirectly to lethal effects. While recognizing the desirability of determining the absorption of those substances only that are sensitive to changes resulting in death, they find no procedure that is entirely satisfactory. Theoretically, the reciprocal of the curve of bactericidal action is perhaps the best absorption curve available. No absolute comparisons were attempted, since the concentration used for each organism was so adjusted that the measurements with the photocell employed were within the range of the greatest accuracy (Fig. 3). In general, the procedure employed was calculated to assure work with living cells, since the intensity of the radiation utilized was far below the threshold of bactericidal action. Nevertheless, paral-

lel experiments were carried out with lethal intensities by way of comparison.

The problem of the absorption spectra of bacteria is obviously related also to the problem of the possible bactericidal effect of wave-lengths of light in the longer ultra-violet and in the visible regions of the spectrum. It is of interest, therefore, to refer to a few of the several papers in which attention has been given to the absorption by specific bacterial cell constituents which might conceivably be important in the bactericidal effects.

Through the work of Kubowitz and Haas (cf. Warburg) and of Otto Warburg (154), among others, the absorption of the bacterial pigment, cytochrome, and of certain oxygen-carrying ferments has been determined. The cytochrome absorption bands of the acetic bacteria are found in the green, *i.e.*, about 5500 to 5600 Å, while the ferro-carbon dioxide combination of the respiratory ferment has been identified in the same organism in the yellow, at 5930 Å. This type of study has been extended to other bacteria and to yeasts; likewise, other yellow pigments have been found in bacteria, while methemoglobin has been assumed to be present in certain organisms—from the absorption bands in the red.

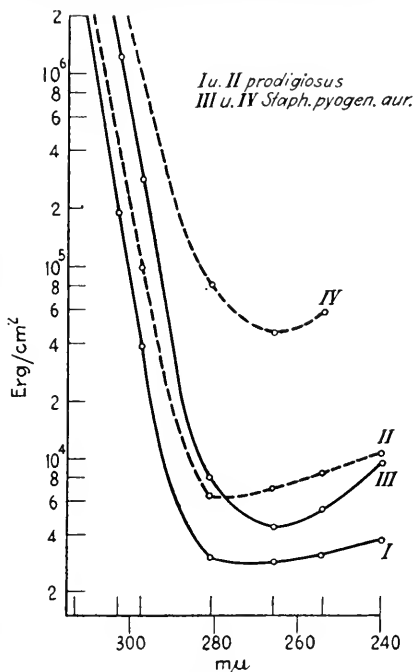

FIG. 3.—Sensitivity curve of *B. prodigiosus* and *Staph. aureus*: continuous lines represent 1 to 10 per cent killing, and broken lines 90 to 100 per cent killing. (From Ehrismann and Noethling, 45.)

RELATIVE SENSITIVITY

Some differences in the sensitivity of various species of bacteria to the lethal effect of light have been consistently reported. The earlier investigations are of but little value, since such factors as the concentration in cells, presence of absorptive substances in the media or among the by-products, were not taken into consideration. Extensive comparative studies made under conditions excluding the influence of other modifying factors are not available today, although it seems reasonable to assume that differences in the thickness or color of the cell wall, somatic pigmentation, and the presence of other nonprotoplasmic light-absorbing substances might result in differences of resistance of minor magnitude

even if "protoplasmic" sensitivity were in this respect less variable. Among those studies reporting comparative differences a few only will be cited as examples, each in the order of increasing sensitivity: (Larsen, 93a) *B. typhi muris*, *B. coli commune*, *B. typhi*, *Staphylococcus pyogenes citreus*, *B. prodigiosus*, *Staphylococcus pyogenes albus*, *Staphylococcus pyogenes aureus*, *B. pyocyaneus*, and *B. cyanogenus* (the first being killed in 60 min., and the last in 25 min.); (Bisceglie, 17) *B. pyocyaneus*, *Staphylococcus aureus*, *B. anthracis*; (Ehrismann, 44a) *B. diphtheriae*, *B. prodigiosus*, *B. coli*, *Staphylococcus pyogenes aureus*, *Vibrio cholerae*, and *B. typhi*.

Bang (8c) found little difference between the tubercle bacillus and *Staphylococcus pyogenes aureus*. Pothoff (123), using 12 species or strains of bacteria in water suspensions, could detect no striking differences in their relative resistance to radiation. Several strains of *B. coli* were killed in about 2 min. Two of the forms of *Staphylococcus pyogenes* were killed in 30 sec., and one in 60 sec. One unnamed species was reported killed in 15 sec. Among seven species studied by Bayne-Jones and Van der Lingen (10), no significant differences in resistance were found. Likewise Gates (59) and Wyckoff (166) reported that the order of resistance of *Staphylococcus aureus* and *B. coli* is much the same. Contrary to the general evidence, Wiesner (160) assumes that there are bacteria (Luftkeime) in nature accommodated to the strongest sunlight, and not ordinarily injured by the action of light. It was more or less characteristic of that period to regard the animal parasitic and saprophytic bacteria as likely to possess greater sensitivity toward light on the ground of habitat adjustment, and Wiesner seems to accept this view.

Ward (155), Arloing (4, 5), and others among the earlier students of lethal light effects, observed that the spores of bacteria as well as vegetative stages are killed with suitable length of exposure, although some confusion developed in respect to the comparative resistance of spores and vegetative stages. Arloing (5) reported anthrax spores less resistant than vegetative stages, while Jansen (82) in an extensive study declared that the spores are about 5 to 7 times as resistant as the vegetative form of bacteria in general. Pothoff (123) reported the extent of growth merely by descriptive terms, showing that the vegetative form of anthrax gave about the same amount of killing in 5 sec. as was obtained in 30 sec. with spores. Using *B. subtilis*, at a concentration of 1/10,000, the vegetative form was reduced to 5 colonies after an exposure of 45 sec., whereas 3 min. were required to reduce the spore stage to occasional colonies; with *B. mesentericus*, spores were also more resistant, but the difference was less striking.

In some comparative experiments with plant viruses, Duggar and Hollaender (42) exposed *B. subtilis* and *B. megatherium* to monochromatic ultra-violet in a suspension containing physiological salt solution and traces of bouillon and of the virus preparation. At a survival value of

85 per cent, the maximum killing of spores was at $\lambda 2650 \text{ \AA}$, where the energy requirement was approximately $18.2 \times 10^3 \text{ erg/cc.}$; whereas with the vegetative stage the same wave-length was most efficient, but the energy requirement was $16.5 \times 10^3 \text{ erg/cc.}$ It should be noted, however, that at high survival percentages the energy requirements for killing the vegetative and the spore stages are more nearly equal, becoming farther apart as the survival value diminishes. Accordingly, qualitative experiments, or those giving comparative values for practically complete killing, do not adequately present this relation. Nevertheless, it seems clear that spore stages are more resistant than vegetative cells, and no doubt the extent of this difference is dependent somewhat upon the age of the vegetative cells with which the comparison is made and upon other conditions as well.

Such results as those just referred to are a striking indication of the fact that there is very little relation between heat resistance and light resistance. It is to be noted, for example, that the spores of *B. anthracis* are almost as readily killed by light as are vegetative stages, whereas the spore stage is strongly resistant to high temperatures. In the case of *B. subtilis*, many spores withstand boiling for 15 min., yet the vegetative stage will scarcely withstand an exposure of 15 min. at 65°C . The papers of Pothoff, Ehrismann, and Duggar and Hollaender should be consulted for the technique of securing spores and vegetative stages of suitable purity.

Reports of the effects of age of the bacterial cell on resistance to irradiation are not consistent. Bang (8) reported increasing resistance with age, up to 62 hours, and Gates, working with *Staph. aureus*, found "the recently divided and genetically and metabolically active bacteria in the four-hour culture were appreciably less resistant to the ultra-violet energy" than cultures 28 or 52 hr. old. On the other hand, Stenstrom and Gaida (144), among others, have obtained results indicating greater resistance in *B. coli* as cultures 24 hr. old than as cultures from 1 to 6 weeks old. Apparently the problem of the age relation is not so simple as has been assumed. In the case of organisms adhering in twos or in chains while the cells are young, accurate comparative counts are difficult; while with old cultures many of the cells are dead previous to exposure, and if intensity measurements are made, there is obviously much ineffective absorption.

X-RAYS

The earlier work on the effects of X-rays on bacteria was very largely negative, as might be expected when viewed in retrospect, if due consideration is given to the probable intensities of the radiation and to other conditions of the experimental work. Of this earlier work only the briefest indications need be furnished. Stimulated by the work of Buchner on

the lethal action of ultra-violet radiation, Minck (103) in 1896 was apparently the first to undertake a determination of the efficiency of X-rays as a bactericidal agency. He used a strain of the typhoid bacillus, streaking the surface of agar plates, and exposing certain areas as long as 8 hr., at a distance of 10 cm., to radiation from a Hittorf tube. Following an incubation period, no effect of the irradiation could be detected from the gross appearance of colony development.

Among others investigating X-ray effects with negative results may be mentioned Beck and Schultz (11). Negative results were also obtained by Wittlin (163) using six species of bacteria exposed in tubes of peptone bouillon, subcultured before and after exposure. In fact, while negative results were being generally reported at this time (1896-1897) indications were accumulating which were interpreted as showing indirect effects of radiation on bacteria; thus animals inoculated with the tubercle bacillus were irradiated and compared with similarly inoculated and unirradiated controls with respect to disease development. In this way some positive indications were furnished. Nevertheless, more consideration in establishing the bactericidal action of these rays should be given to such investigations as those of Rieder (130), in 1898. He used six organisms (*B. anthracis*, *B. coli*, *B. diphtheriae*, the tubercle organism, a streptococcus, *Staphylococcus pyogenes aureus*, and *Vibrio cholerae*), exposing these on agar or gelatin media. They were killed after irradiation intervals of 40 to 60 min. at a distance of 10 cm. On the whole, less consistent and satisfactory results were obtained with some of these organisms when exposed in bouillon or in a meat extract medium 5 mm. in depth. The general trends of such results were confirmed by the later work of Rieder (130) and others.

With the intensities which continued to be employed during the next quarter century few significant advances were made; true, exposure periods were considerably extended, but this practice could not be expected to yield satisfactory results under conditions favorable for continued growth and multiplication. Even less satisfactory were the results in which cultures were exposed for an interval on successive days. Results obtained by Russ (134) were important in showing that while the irradiation of inoculated animals might increase their resistance to the disease normally induced, still such intensities as he employed produced no evident effect on the morphology or physiology of the bacteria when irradiation of these organisms was carried out independently. Haberland and Klein (69a) worked with a spark length of 35 cm. and current 2 to 2.5 ma., giving an exposure up to twice that required for 1 H.E.D., with negative effects on a "human" strain of the tubercle bacillus, while Lange and Fraenkel (92) found that a dosage of 10 H.E.D. (2 ma., and spark length 7 to 8 cm.) greatly diminished the infectivity of a culture of this organism 33 days old, as evidenced by inoculation of the organism

into guinea pigs. It was also determined that cultures younger than about four weeks were more resistant to radiation.

In spite of further studies on lethal effects and on modification of virulence or of pigmentation, the problem remained controversial and quantitative data were few. In 1925, Klövekorn (86) used *Staphylococcus pyogenes aureus* and *Bacillus coli*, with radiation from an Apex apparatus provided with an attachment for a Coolidge tube. The intensities are given in terms of SN (1 SN being equivalent to 600 r). The bacterial preparations were arranged to test the effects under several conditions: thus the materials for exposure were (a) growing agar streak cultures; (b) bouillon cultures 24 hr. old; (c) suspensions in physiological salt solution; and (d) plate cultures 25 to 30 days old. In advance it was determined that effects upon the media employed were insufficient to be regarded as a factor in the results. Up to a dosage of 60 SN there was no change in time or character of growth, even in respect to color; while in bouillon and in physiological salt solution changes in cultural behavior began at 80 SN, yet in no case were there definite, lethal effects up to 120 SN, the maximum intensity employed. On the other hand, cultures 28 to 30 days old, on agar plates, showed diminished growth capacity at 80 SN, and complete killing at 120 SN. Reasonably substantiating results were obtained with *B. coli*. The findings were also verified by use of the "Tusche" (brushed film) culture technique. Summarizing, it was found that modification of cultural characteristics may be brought about at 60 to 80 SN, while lethal effects at 110 to 120 SN are produced only when the exposed cultures are old (28 to 30 days, under these conditions). Klövekorn's paper should be consulted for brief reviews of other earlier papers not mentioned in this discussion.

Many of the more recent studies on the effects of X-rays on bacteria, as well as on other organisms, have had the advantage—on the biological side—of improved techniques and conditions, of higher radiation intensities, and of a more accurate measurement of dosage in roentgen units. An appreciation of all these developments is important in the later interpretations and discussions. In his general review of X-ray effects, Packard (114) has analyzed and systematized the results reported from a variety of biological material, and the reader is referred to that paper for broader orientation. Here it is possible to consider only a few of the many relevant lines of discussion.

Unfortunately, most of the quantitative X-radiation work on bacteria relates to lethal effects only. From the data now available it is well known that if any population of microorganisms is exposed to radiation inducing lethal effects, one may plot the percentage of survivals against the time of exposure and the results will appear in the form of a logarithmic or of an S-shaped curve. Biologists are generally agreed that such S-shaped curves are characteristic of a normal variability of a population

in sensitivity. Similar curves are produced, of course, by such a diffuse lethal factor as temperature. An interesting physical interpretation of effects of this nature is the assumption that any organism or cell will die as soon as it has received the required, or critical, number of X-ray quanta; that is, the probability feature applies to the number of quantum hits received, and not to the variability of the biological material.

The further suggestion was made from the work of Crowther with *Colpidium* that a hit on a particular, sensitive spot of the protoplasm is necessary to cause death. There has been much discussion of this view and modifications of it both in regard to the size and the distribution of the sensitive constituents and in respect to the effects of quanta of different energy content. Holweck and Lacassagne (78, 88) and Glocker (65), among others, are prominently associated with work done in this field. An extended discussion, with literature, will be found in a recent paper of Lacassagne (89), and to this the reader is referred, likewise to the discussion by Gowen (Paper XLIII) in this work. Wyckoff has also emphasized the physical side, and some of his results will be given by way of illustration.

In two papers Wyckoff (164, 165) has reported quantitative studies on the lethal effects of X-rays on bacteria. The first paper is concerned with effect of soft X-rays and the second with X-rays of different wavelengths. The bacteria were exposed on agar surfaces. Counts were made after incubation on equal exposed and adjacent control areas. In the first experiments, *B. coli* and *B. aertrycke* were used, the assumption being that these organisms give a distribution in single cells, an assumption which appears to the reviewer less real than ideal. Soft X-rays were supplied from the general radiation of a tungsten tube operated at 12-kv. peak and 8 ma., and also by the K radiation of copper. Intensity measurements were made. Survival values were plotted against time. The results indicate that there is no significant difference in the sensitiveness of the two species of bacteria. The killing effect is semilogarithmically linear. Basing the conclusion on a mathematical-physical analysis, it is concluded that death is caused by the absorption of a single X-ray quantum of energy. Moreover, the ratio of quanta absorbed to killing is about 20/1. It would appear that the "sensitive cell constituents" must have a volume less than 0.06 of the entire cell. Effects other than lethal ones were not given special consideration.

MISCELLANEOUS CONSIDERATIONS

Apparatus and Procedures.—A general discussion of radiation techniques and procedures has no place in this paper, but brief indications regarding special applications may be appropriately given. It is clear that the source of radiation and the optical or filter systems or other

apparatus needed in obtaining the wave-lengths of radiation required should be the best procurable for the purpose, as should the installation for energy measurements. The exposure vessels or culture procedure used may vary widely, depending upon the nature of the problem. The agar-plate technique, whereby a suspension of bacteria of known concentration is washed over the hardened agar surface and then selected areas of this surface exposed to radiation, commends itself on account of simplicity. Probably this is reasonably accurate, but many have found difficulty in obtaining an equal distribution of the bacteria, and this difficulty is increased when the organism is produced in chains or adheres in groups. The accuracy of colony counts depends upon the concentration, and there are narrow time limits within which the work may be satisfactorily carried out. The agar-surface technique is not applicable when the period of exposure is greater than the division time of the cells, and it is unsuitable for work with viruses and enzymes.

The suspension method (the bacteria being suspended in physiological salt solution) may be used with a high degree of accuracy but not without careful study of each organism used. It permits a wide variation in the concentration of organisms, since plating out from suspensions may be made after any interval of time. The progressive rate of killing may be followed relatively accurately with any range in concentration (through the dilution plate series) desired. Ideally, washed bacteria might be employed, but ordinarily washing promotes clumping and apparently increases the percentage of inactive or dead cells, so that caution is necessary. A source of error with the suspension method is to be found in the amount of scattered light in the preparation. Scattering is not excluded in the agar preparations but is no doubt at a minimum. In this connection reference should be made to the work of Vlès (152) who has considered scattering in detail in relation to the radiation of bacterial suspensions. The purified suspension also offers less opportunity for the influence of any indirect effects through changes in the medium induced by long exposure or high intensity. It is the only technique available for comparative work with viruses and enzymes.

Fluorescence in Relation to Bacteria.—Studies on the fluorescence of bacteria are relatively recent. In relation to the general problem of fluorescence much information has been brought together by Radley and Grant (124). Burge and Neill (22) reported fluorescing bacteria much less sensitive to light than those which are nonfluorescing. The investigation made by Gassul and Žolkovič (57), using $\lambda 3650 \text{ \AA}$, led to the claim that types of bacteria might be distinguished by characteristic fluorescent properties. This work was not supported by the observations of Danielson (30), who found this property insufficiently definite for application in species diagnosis. The more extensive observations of Lasseur, Dupais, and Lécaille (94) included 33 species of bacteria and

13 yeasts. Their conclusion was that differentiation on this basis was impracticable and that nearly all species exhibited fluorescence at $\lambda 3650 \text{ \AA}$. Giese and Leighton (63) have also studied fluorescence as excited by monochromatic light. It is to be noted that consideration should be given the possibility that fluorescence may be a property of the excretion products of the bacterial cell, therefore, in any examination respecting this property as an intracellular attribute the cells should be washed. On the other hand, fluorescence may be studied in relation to the action of a particular organism on a particular substrate. The fluorescence spectrum of bacteria and fungi under violet and ultra-violet irradiation was studied by Dhéré, Glücksmann, and Rapetti (31), using both spectroscopic and spectrographic methods. They attribute the fluorescent quality of these organisms to the formation of porphyrins during the course of growth. From *Mycobacterium smegmatis*, e.g., there was distinguished a strong emission band in the orange, corresponding closely with the chief band of coproporphyrin in a neutral medium.

Photodynamic Effects.—It would appear to be difficult at present to evaluate definitely the influence resulting from the addition to the substrate of substances having fluorescent or "sensitizing" properties upon the physiological effects of visible and ultra-violet radiation. Von Tappeiner and his associates, especially Jodlbauer, (cf. 83, 147) have contributed a series of articles on this subject, and many others (37, 79, 98, 141) have extended this field of inquiry. Von Tappeiner and Jodlbauer used a great variety of compounds in such groups as fluorescenes, anthracenes, quinines, and other dye-furnishing substances primarily absorptive in the visible. They (147) stressed the importance of fluorescing substances and have suggested that some of the earlier studies did not eliminate the possibility of temperature effects. They also present evidence that the photodynamic effect is independent of the production of toxic substances in the substrate, although in general their controls were merely tests in which the fluorescing agents were added to the cultures maintained in the dark. Within the range of visible radiation it was found that the presence of oxygen may be essential; in the ultra-violet the effect is not dependent upon oxygen (cf. 37).

According to Dreyer (37), the addition of certain fluorescing substances, notably erythrosin, promotes killing in the yellow and yellow-green, in fact, rendering the bacteria sensitive in this region as well as in the ultra-violet. Erythrosin was considered the best sensitizer with *B. prodigiosus*. In some of the relatively recent photodynamic work contrary views respecting the significance of such agents have been advanced (141). The relation of dye effects to their absorption spectra has been emphasized (98), and even the bactericidal effect of neon light in the presence of photodynamic agents (Grumbach, 67) has been studied. Further systematic, quantitative work is much needed in

this field, but it should be recognized at the outset that the photochemical reactions may be complicated, and accurate interpretation correspondingly difficult.

Remarks.—In so brief a review of the effects of radiation on bacteria many relevant topics are necessarily left out of consideration. Observations on the effects of radium are sufficiently extensive to justify inclusion, although largely qualitative. Moreover, a special paper of this work (Gager, Paper XXX) is devoted to the general effects of radium on plants. Wyckoff and Rivers (167) have studied the influence of cathode rays, and the action of polarized light (15, 59) has not been neglected. Bacterial luminescence is a large problem and phototaxy an interesting one, but both have been looked upon as outside the province of this article. Many investigators have given some attention to the consequences of sublethal irradiation of pathogenic bacteria, and it is well known that modifications of pathogenicity may occur, but until quantitative work has been done in this direction the picture is scarcely more than outlined. To the reviewer it appears also that the most attractive lines of work await the investigator—in general, the modification of rate or quality of such physiological relations as fermentation and metabolic products, respiration, pigment development, and growth behavior, as well as modification of cell or colony form and the influence on spore formation and on genetic expression. Finally, it would be instructive to attempt to give a comparative review, at least in relation to proteins, enzymes, viruses, protoplasm, bacteria, and other unicellular organisms.

REFERENCES

1. ACQUA, V. DALL', and V. DE ANTONI. Ricerche sperimentale sull' azione battericida delle radiazioni di diversa lunghezza d'onda. *Radiol. Med.* **18**: 869-887. 1931.
2. AMSTER, S., and P. S. MEYER. Der Einfluss von Astringentien auf die Lichtempfindlichkeit von Bakterien. *Klin. Wochensh.* **3**: 2098-2099. 1924.
3. ARCY, R. F. D', and W. B. HARDY. Note on the oxidising powers of different regions of the spectrum in relation to the bactericidal action of light and air. *Jour. Physiol.* **17**: 390-393. 1894-1895.
4. ARLOING, S. Influence de la lumière sur la végétation et les propriétés pathogènes du *Bacillus anthracis*. *Compt. Rend. Acad. Sci. [Paris]* **100**: 378-381. 1885. (See also *Ibid.* **101**: 511-513, 535-537. 1885; **104**: 701-703. 1887.)
5. ARLOING, S. Influence de la lumière blanche et de ses rayons constituants sur le développement et les propriétés du *Bacillus anthracis*. *Arch. Physiol. Norm. et Path. Ser. 3*, **7**: 209-235. 1886.
6. ARSONVAL, D', and CHARRIN. Influence des agents atmosphériques en particulier de la lumière, du froid, sur la bacille pyocyano-gène. *Compt. Rend. Acad. Sci. [Paris]* **118**: 151-153. 1894.
7. BACHEM, A., and M. A. DUSHKIN. Time factors concerned in the germicidal action of ultra-violet light. *Proc. Soc. Exp. Biol. and Med.* **30**: 700-704. 1933.
- 7a. BAKER, S. L. The estimation of the destructive effects of ultra-violet rays. *In* *British System of Bacteriology* **9**: 282-288. 1931.

8. BANG, SOPHUS. Die Wirkungen des Lichtes auf Mikroorganismen. Mitt. Finsen's Med. Lysin. **2**: 1-107. 1901. [See also Ibid. (a) **3**: 97-112. 1903; (b) Ibid. **9**: 164. 1905; (c) **7**: 14-40. 1914.]
9. BARNARD, J. E., and H. MORGAN. Upon the bactericidal action of some ultra-violet radiations as produced by the continuous current arc. Proc. Roy. Soc. [London] **72**: 126-128. 1903.
10. BAYNE-JONES, S., and J. S. VAN DER LINGEN. The bactericidal action of ultra-violet light. Bull. Johns Hopkins Hosp. **34**: 11-16. 1923.
11. BECK, M., and P. SCHULTZ. Ueber die Einwirkung sog. monochromatischen Lichtes auf die Bakterienentwicklung. Zeitsch. Hyg. und Infektionskr. **23**: 490-496. 1896.
12. BECQUEREL, P. L'action abiotique de l'ultraviolet et l'hypothèse de l'origine cosmique de la vie. Compt. Rend. Acad. Sci. [Paris] **151**: 86-88. 1910.
13. BEDFORD, T. H. The nature of the action of ultra-violet on microorganisms. British Jour. Exp. Path. **8**: 437-444. 1927.
14. BEHRING, FR. Zur Biologie der physiologischen und pathologischen Wirkungen des Lichtes. Ergeb. Allgem. Path. und Path. Anat. **17**: 790-835. 1914.
15. BHATNAGAR, S. S., and R. B. LAL. Effects of polarised light on bacterial growth. Nature **117**: 302. 1926.
16. BIE, V. Untersuchungen über die bakterientötende Wirkung der verschiedenen Abteilungen des Spektrums. Mitt. Finsen's Med. Lysin. **1**: 40-77. 1900. (See also Ibid. **7**: 41-64, 65-77, 78-97. 1904; **9**: 5-74. 1905.)
17. BISCEGLIE, V. L'influenza dei raggi ultravioletti sui germi e sulle tossine. Gior. Batter. e Immun. **2**: 144-153. 1927.
18. BOISSEvain, C. H. The effect of beta-rays on bacterial growth. Amer. Rev. Tuberc. **14**: 172-176. 1926.
19. BROWNING, C. H., and S. RUSS. The germicidal action of ultra-violet radiation and its correlation with selective absorption. Proc. Roy. Soc. [London] **90**: 33-39, 107. 1917. (See also Arch. Radiol. Electrother. **23**: 85-90. 1918.)
20. BUCHNER, H. Ueber den Einfluss des Lichtes auf Bakterien. Centralbl. Bakt. und Parasitenk. Abt. 1. **11**: 781-783; **12**: 217-219. 1892. (See also Arch. Hyg. **17**: 179-204. 1893.)
21. BURGE, W. E. The action of ultra-violet radiation in killing living cells such as bacteria. Amer. Jour. Physiol. **43**: 429-432. 1917.
22. BURGE, W. E., and A. J. NEILL. The comparative rate at which fluorescent and non-fluorescent bacteria are killed by exposure to ultra-violet. Amer. Jour. Physiol. **38**: 399-403. 1915.
23. BURGER, G. N. The lethal action of soft X-rays on microorganisms. Bull. Basic Sci. Res. **3**: 71-81. 1931. (See also Ibid. **2**: 46-54. 1928.)
24. BUSCK, G. Lichtbiologie. Eine Darstellung der Wirkung des Lichtes auf lebende Organismen. Mitt. Finsen's Med. Lysin. **8**: 1-147. 1904.
25. CERNOVODEANU, P., and V. HENRI. Action des rayons ultraviolets sur les microorganismes et sur différents cellules. Étude microchimique. Compt. Rend. Acad. Sci. [Paris] **150**: 52-54, 549-551, 729-731. 1910.
26. CHMELEWSKI, P. Schutzimpfung, künstliche Infektion. Krankheiten, Entwicklungshemmung und Vernichtung der Bakterien, etc. Wratsch **20**: 1892.
27. CLARK, J. H., C. MCD. HILL, M. HANDY, J. CHAPMAN, and D. D. DONAHUE. Ultra-violet radiation and resistance to infection. Congrès Internat. Lum. Copenhagen, 1932: 458-463.
28. CLAUS, W. D. Enhanced lethal effects of X-rays on *Bacillus coli* in the presence of inorganic salts. Jour. Exper. Med. **57**: 335-347. 1933.
29. COBLENTZ, W. W., and H. R. FULTON. A radiometric investigation of the germicidal action of ultra-violet radiation. Scient. Papers Bur. Standards. No. 495. **19**: 641-680. 1924.

30. DANIELSEN, E. Zur Unterscheidung von Bakterienkulturen mit Hilfe der Quarzlampe. *Centralbl. Bakt. und Parasitenk. Abt. 1.* **115**: 225-228. 1930.
31. DHÉRE, C., S. GLÜCKSMANN, and L. RAPELLI. Sur les applications de la spectroscopie et de la spectrographie de fluorescence en microbiologie. *Compt. Rend. Soc. Biol. [Paris]* **114**: 1250-1253. 1933.
32. DIEUDONNÉ, A. Beiträge zur Beurtheilung der Einwirkung des Lichtes. *Arch. Kais. Gesundheitsamte* **9**: 404-413. 1894.
33. DILLON WESTON, W. A. R. Studies on the reaction of disease organisms to certain wave-lengths in the visible and invisible spectrum. *Scient. Agric.* **12**: 352-366. 1932. (*See also Ibid.* **12**: 81-90. 1932.)
34. DOWNES, A. On the action of sunlight on microorganisms, etc. with a demonstration of the influence of diffused light. *Proc. Roy. Soc. [London]* **40**: 14-22. 1886.
35. DOWNES, A., and T. P. BLOUNT. Researches on the effect of light upon bacteria and other organisms. *Proc. Roy. Soc. [London]* **26**: 488-500. 1877. (*See also Ibid.* **28**: 199-212. 1879.)
36. DOZOIS, K. P., R. P. TITSLER, M. W. LISSE, and W. P. DAVEY. The effect of low voltage X-rays on the electrophoretic migration velocity, viability and pH of *Escherichia coli* suspensions. *Jour. Bacteriol.* **24**: 123-132. 1932.
37. DREYER, G. Sensibilisierung von Mikroorganismen und tierischen Geweben. *Mitt. Finsen's Med. Lysinstit.* **7**: 132-150. 1904.
38. DRIGALSKI, V. Zur Wirkung der Lichtwärmestrahlen. *Centralbl. Bakt. und Parasitenk. Abt. 1.* **27**: 788-791. 1900.
39. DUCLAUX, E. Sur la durée de la vie chez des germes des microbes. *Ann. Chim. et Phys. Ser. VI* **5**: 1-59. 1885.
40. DUCLAUX, E. Influence de la lumière du soleil sur la vitalité de micrococcus. *Compt. Rend. Acad. Sci. [Paris]* **101**: 395-398. 1885. (*See also Ibid.* **100**: 119-121. 1885; and *Compt. Rend. Soc. Biol. [Paris]* **37**: 508-510. 1885.)
41. DUCLAUX, E. Action de la lumière sur les microbes. *Revue critique. Ann. Inst. Pasteur* **1**: 88-92. 1887.
42. DUGGAR, B. M., and A. HOLLAENDER. Irradiation of plant viruses and of microorganisms with monochromatic light. I, II. *Jour. Bacteriol.* **37**: 219-239, 241-256. 1934.
43. EBERT, B. T., and L. H. PERETZ. Wirkung der Radiumemanation auf Bakterien, filtrierbaren Virus der Peripneumonie und Bakteriophagen. *Centralbl. Bakt. und Parasitenk. Abt. 1.* **121**: 258-267. 1931.
44. EHRLMANN, O. Über den Mechanismus der baktericiden Wirkung ultravioletter Strahlen. *Jour. Hyg. und Infektionskr.* **111**: 619-643. 1930. [*See also (a) Ibid.* **110**: 746-754. 1929.]
45. EHRLMANN, O., and W. NOETHLING. Ueber die bactericide Wirkung monochromatischen Lichtes. *Jour. Hyg. und Infektionskr.* **113**: 597-628. 1932.
46. EIDINOW, A. The bactericidal effect of ultra-violet rays. *British Jour. Radiol.* **31**: 35-40. 1926. (*See also British Med. Jour.* **2**: 160-161. 1927.)
47. EIDINOW, A. Ueber die baktericide Wirkung der ultravioletten Strahlen. *Strahlentherapie* **25**: 730-734. 1927.
48. EIDINOW, A. Ultraviolet irradiation and experimental tumors. *Acta Radiol. [Stockholm]* **14**: 408-418. 1933.
49. ESMARCH, E. VON. Ueber Sonnendesinfektion. *Zeitsch. Hyg.* **16**: 257-267. 1894.
50. EULER, H. VON. Ueber das Wachstum von Mikroorganismen auf bestrahlten lipoidhaltigen Nährböden. *Biochem. Zeitsch.* **165**: 23-28. 1925.
51. FRIEDLAND, M. Zur Frage des Einflusses der Strahlenergie auf das Wachstum der Tuberkelbazillen in vitro. *Centralbl. Bakt. und Parasitenk. Abt. 1.* **95**: 404-412. 1925.

52. FURNISS, A. The action of light on bacteria. *Science Progr.* **26**: 264-269. 1930.
53. GAERTNER, OTTO. Die Bedeutung der weichen Röntgenstrahlen für Bestrahlungsversuche mit Bakterien. *Strahlentherapie* **22**: 327-336. 1926.
54. GAERTNER, OTTO, and G. H. KLÖVEKORN. Röntgenstrahlen und einzellige Lebewesen. III. *Strahlentherapie* **26**: 211-213. 1927.
55. GAERTNER, S., and J. SZATHMARY. Ueber die Antigenfunktion der mit ultravioletten Strahlen behandelten Bakterien. *Zeitschr. Immunitätsforsch. und Exp. Therap.* **78**: 256-263. 1933.
56. GAERTNER, S. Die Ausfällbarkeit der ultraviolet bestrahlten Bakterien. *Zeitsch. Immunitätsforsch. und Exp. Therap.* **80**: 493-507. 1933.
57. GASSUL, R., and A. ŽOLKOVIČ. Über Differenzierungsversuche an Bakterienkulturen mit Hilfe der sogenannten Woodsehen Strahlen. *Centrabl. Bakt. und Parasitenk. Abt. 1.* **104**: 503-507. 1927.
58. GATES, F. L. On the nuclear derivatives and the lethal action of ultraviolet light. *Science* **68**: 479-480. 1928.
59. GATES, F. L. A study of the bactericidal action of ultraviolet light. I, II. *Jour. Gen. Physiol.* **13**: 231-248, 249-260. 1929. (*See also Proc. Soc. Exp. Biol. and Med.* **21**: 61-62. 1923.)
60. GATES, F. L. The absorption of ultraviolet light by bacteria. *Jour. Gen. Physiol.* **14**: 31-42. 1930.
61. GATES, F. L. The reaction of individual bacteria to irradiation with ultraviolet light. *Science* **77**: 350. 1933.
62. GEISLER, T. Zur Frage über die Wirkung des Lichtes auf Bakterien. *Centrabl. Bakt. und Parasitenk. Abt. 1.* **11**: 161-173. 1892. (*See also Arch. Med. Exp. et Anat. Path.* 1891, p. 800.)
63. GIESE, A., and P. A. LEIGHTON. Fluorescence of cells in the ultraviolet. *Science* **77**: 509-510. 1933.
64. GLASER, E. Beiträge zur Kenntnis der Sterilisation mit ultraviolettem Licht. *Wiener Klin. Wochensh.* **24**: 1157-1160. 1911.
65. GLOCKER, R. Quantenprobleme in der Strahlenbiologie. *Naturwissensch.* **19**: 20. 1931.
66. GRIFFITH, H. D., and J. S. TAYLOR. The photometry of therapeutic lamps. *Jour. Hyg.* **25**: 218-224. 1926.
67. GRUMBACK, A. Aus der Bakteriologie. *Photodynamik.* *Schweiz. Med. Wochensh.* **62**: 1089-1090. 1932.
68. GUTFELD, F. VON, and L. PINCUSSEN. Untersuchungen über die Wirkung des Lichtes auf Bakterien. *Centrabl. Bakt. und Parasitenk. Abt. 1.* **109**: 107-115. 1928; **118**: 187-188. 1930.
69. HAASE, W., and E. SCHLIEPHAKE. Versuche über den Einfluss kurzzeitiger elektrischer Wellen auf das Wachstum von Bakterien. *Strahlentherapie* **40**: 133-158. 1931.
- 69a. HABERLAND, H. F. O., and K. KLEIN. Die Wirkung der Röntgenstrahlen auf Tuberkelbazillen. *Münch. Med. Wochensh.* **68**: 1049-1050. 1921.
70. HALBERSTAEDTER, L. Mikrobiologische Grundlagen der Strahlentherapie. *Handb. Ges. Strahlenheilk.* **1**: 484-508. 1928.
71. HARRIS, F. I., and H. S. HOYT. The action of ultra-violet on certain bacteria in relation to specific absorption by amino acids. *Univ. California Publ. (Path.)* **2** (21): 245-250. 1919.
72. HAUSMANN, W. Grundzüge der Lichtbiologie und Lichtpathologie. VIII. Sonderband zu "Strahlentherapie." 231 p. Berlin-Wien, 1923.
73. HENRI, V. (Mme. & M.) Variation du pouvoir abiotique des rayons ultraviolets avec leur longueur d'onde. *Compt. Rend. Soc. Biol. [Paris]* **73**: 321-322. 1912. (*See also Compt. Rend. Acad. Sci. [Paris]* **155**: 315-318. 1912.)

- 73a. HENRI, V. *Études de photochimie*. Gauthier Villars et Cie; Paris, 1919.
74. HENRI, V., and V. MOYCHO. Action des rayons ultraviolets monochromatique sur les tissus. Mesure de l'énergie de rayonnement correspondant au coup de soleil. *Compt. Rend Acad. Sci. [Paris]* **158**: 1509-1511. 1914.
75. HERTEL, E. Ueber Beeinflussung des Organismus durch Licht, speziell durch die chemisch wirksamen Strahlen. *Zeitsch. Allgem. Physiol.* **4**: 1-43. 1904. (See also *Ibid.* **5**: 95-122. 1905.)
- 75a. HEYBOTH, F. F., and J. R. LOOFBOUROW. The lethal action of radiant energy on living cells. *Physical Rev.* **45**: 126. 1934.
76. HILL, L., and A. EIDINOW. The biological action of light. *Proc. Roy. Soc. [London] B.* **95**: 163-180. 1923. (See also *British Med. Jour.* **1**: 388-389. 1930.)
77. HOLLAENDER, A. Bibliography of the application of electrooptic techniques to biological problems. Rockefeller Foundation, 1935.
78. HOLWECK, F., and A. LACASSAGNE. Sur le mécanisme de l'action cryocautique des radiations. *Compt. Rend. Soc. Biol. [Paris]* **140**: 766-768. 1930.
79. HURER, H. Weitere Versuche mit photodynamischen, sensibilisierenden Farbstoffen (Eosin, Erythrosin). Prüfung der Wirkung des Tageslichtes auf die Lebensfähigkeit und Virulenz von Bakterien, auf Toxine und Antitoxine und auf das Labferment. *Arch. Hyg.* **54**: 53-88. 1909.
80. JAMESON, J. The influence of light on the development of bacteria. *Nature* **26**: 244-245. 1882.
81. JANOWSKI, T. Zur Biologie der Typhusbazillen. Die Wirkung des Sonnenlichts. *Centrallbl. Bakt. und Parasitenk. Abt. 1.* **8**: 167-172. 1890.
82. JANSEN, H. Über die Widerstandsfähigkeit der Bakteriensporen gegenüber dem Lichte. *Mitt. Finsen's Med. Lysin.* **4**: 127-157. 1903.
83. JODLBAUER, A., and H. VON TAPPEINER. Ueber die Wirkung photodynamischer fluoreszierender) Stoffe auf Bakterien. *Münch. Med. Wochens.* **51**: 1096-1097. 1904.
84. KEDZOIR, L. Ueber den Einfluss des Sonnenlichtes auf Bakterien. *Arch. Hyg.* **36**: 323-334. 1889.
85. KLÖVEKORN, G. H., and O. GAERTNER. Die Einwirkung der Roentgenstrahlen auf einzellige Lebewesen. *Strahlentherapie* **23**: 148-154. 1926.
86. KLÖVEKORN, H. Die Einwirkung der Röntgenstrahlen auf Bakterien. *Strahlentherapie* **20**: 354-377. 1925.
87. KRUSE, W. Ueber die hygienische Bedeutung des Lichtes. *Zeitsch. Hyg.* **19**: 313-333. 1895.
88. LACASSAGNE, A. Action des rayons X de grande longueur d'onde sur les microbes. Établissement de statistiques précises de la mortalité des bactéries irradiées. *Compt. Rend. Acad. Sci. [Paris]* **188**: 200-202. 1929.
89. LACASSAGNE, A. Le problème des quanta en radiobiologie. *Jour. Radiol. et Electrol.* **18**: 553-560. 1934.
90. LAGERBERG, O. Vergleichende Untersuchungen über die Widerstandsfähigkeit der Sporen und der vegetativen Formen einiger sporenbildender Bakterien gegenüber ultraviolettem Licht. *Zeitsch. Immunitätsforsch. und Exp. Ther.* **28**: 186-197. 1919.
91. LAL, R. B., and K. N. MATHUR. The effects of polarised light on bacterial life. *Indian Jour. Med. Res.* **14**: 257-262. 1926.
92. LANGE, L., and M. FRAENKEL. Die Wirkung von Röntgenstrahlen auf Tuberkelbazillen. *Klin. Wochens.* **2**: 1161-1162. 1923.
93. LAROQUETTE, MARAMOND DE. Expériences sur l'action bactéricide de la lumière solaire. *Ann. Inst. Pasteur* **32**: 170-192. 1918.
- 93a. LARSEN, A. L. Haben die verschiedenen Bakterienarten dieselbe Widerstandskraft dem Lichte gegenüber? *Mitt. Finsen's Med. Lysin.* **1**: 89-98. 1900.

94. LASSEUR, P., A. DUPAIX, and LÉCAILLE. Fluorescence des corps microbiens. *Trav. Lab. Microbiol. Fac. Pharm. [Nancy]* **4**: 85-94. 1931.
95. LAURENS, H. The physiological effects of radiant energy. 603 p. Chem. Catalog Co.; New York, 1933.
96. LEDOUX-LEBARD. Action de la lumière sur le bacille diphtérique. *Arch. Med. Exp. et d'Anat. Path.* 1893: 779-801.
97. LIECHTI, A. Ueber den Zeitfactor der biologischen Strahlenwirkung. *Strahlentherapie* **33**: 1-54. 1929.
98. LINDEN, H., and F. K. T. SCHWARZ. Ueber die photodynamische Wirkung von Farbstofflösungen auf Bakterien bei Einwirkung des Phosphoreszenzlichtes. *Arch. Hyg.* **106**: 133-146. 1931.
99. LISSE, M. W., and R. P. TITSLER. Effect of irradiation on electrokinetic potential, aggluminability, lysis and pH of *Escherichia coli* suspensions. *Proc. Soc. Exp. Biol. and Med.* **28**: 811-813. 1931.
100. MASHIMO, T. A method of investigating the action of ultraviolet rays on bacteria. *Mem. Coll. Sci. Kyoto Imp. Univ.* **4**: 1-11. 1919.
101. MAYER, E., and M. DWORSKI. The bactericidal action of ultra-violet irradiations of tubercle bacilli. *Amer. Rev. Tuberc.* **26**: 105-111. 1932.
102. MIGNECO, F. Wirkung des Sonnenlichtes auf die Virulenz der Tuberkelbazillen. *Arch. Hyg.* **25**: 361-372. 1895.
103. MINCK, FRANZ. Zur Frage über die Einwirkung der Röntgenschen Strahlen auf Bakterien und ihre eventuelle therapeutische Verwendbarkeit. *Münch. Med. Wochensh.* **5**: 101. 1896. (*See also* *Ibid.* **9**: 202. 1896.)
104. MORRISON, T. F. The effect of polarized light on the growth of luminous bacteria. *Science* **61**: 392-393. 1925.
105. NAND LAL, JEMADAR. The effect of direct sunlight on sealed cultures of organisms. *Indian Jour. Med. Res.* **11**: 445-447. 1923-24.
106. NEUMARK, E. Beitrag zur Frage der desinfizierenden Wirkung des Lichtes. Sein Einfluss auf tierpathogene Erreger. 76 p. R. Schoetz; Berlin, 1907.
107. NEWCOMER, H. S. Bactericidal fluorescence excited by X-rays. *Jour. Exp. Med.* **26**: 657-668. 1917.
108. NEWCOMER, H. S. The abiotic action of ultra-violet light. *Jour. Exp. Med.* **26**: 841-848. 1927.
109. NOBELLE, DE, DE POTTER, and VON HAELST. Action antagoniste des rayons ultra-violetts et infra-rouges. *Ann. Inst. d'Actinol.* **6**: 74-78. 1932.
110. NORRIS, R. J. The increased bactericidal effect of inorganic compounds in the presence of X-rays. *Bull. Basic Sci. Research.* **3**: 21-36. 1931.
111. OEHLISCHLÄGEL, L. Ueber Abtötung von Bakteriensporen durch Licht. *Arch. Hyg.* **91**: 177-181. 1922.
112. OKER-BLOM, M. Ueber die keimtötende Wirkung des ultravioletten Lichtes in klarem, getrübbtem und gefärbtem Wasser. *Zeitsch. Hyg.* **74**: 197-241. 1913. (*See also* *Ibid.* **74**: 242-247.)
113. OLIVI, G. Azione della luce solare sui protofitti patogeni. *Ann. Med. Nav. e Colon* **1**: 109-150, 213-255. 1923.
114. PACKARD, C. E. Biological effects of short radiations. *Quart. Rev. Biol.* **6**: 253-280. 1931.
115. PANSINI, S. Dell azione della luce solare sui microorganismi. *Boll. Soc. Nat. Napoli. Ser. I.* **4**: 44-72. 1890.
116. PASSOW, A., and W. PRIMPAW. Untersuchungen über photodynamische Wirkungen auf Bakterien. *Münch. Med. Wochensh.* **71**: 733-737. 1924.
117. PAULI, W. E., and E. SELGER. Ueber die bactericide Wirkung der Röntgenstrahlen. *Strahlentherapie.* **32**: 761-768. 1929.

118. PERKINS, R. G., and H. WELCH. Bactericidal action of ultra-violet light from a series of carbon arcs with known spectra. *Jour. Prev. Med.* **3**: 363-376. 1929.
119. PHILBERT, A., and J. RISLER. Action de la lumière du neon sur les bactéries. *Compt. Rend. Acad. Sci. [Paris]* **183**: 1137-1139. 1926.
120. PINCUSSEN, L. *Photobiologie*. 543 p. Thieme; Leipzig, 1930.
121. PONZIO, M. Ueber die antagonistische Wirkung der ultravioletten und ultraroten Strahlungen. *Strahlentherapie* **39**: 490-492. 1931.
122. PORCELLI-TITONE, F. Ueber die Beweglichkeit der den ultravioletten Strahlen ausgesetzten Bakterien. *Centralbl. Bakt. und Parasitenk. Abt. 1.* **76**: 54-64. 1915.
123. POTHOFF, P. Ueber die Einwirkung ultravioletter Strahlen auf Bakterien und Bakteriensporen. *Desinfektionen* **6**: 10-20. 1921.
124. RADLEY, J. A., and J. GRANT. *Fluorescence analysis in ultra-violet light*. 219 p. Chapman and Hall, Ltd.; London, 1933.
125. RAPP, R. Ueber den Einfluss des Lichtes auf organische Substanzen mit besonderer Berücksichtigung der Selbstreinigung der Flüsse. *Arch. Hyg.* **48**: 179-205. 1904.
126. RAUM, J. Der gegenwärtige Stand unserer Kenntnisse über den Einfluss des Lichtes auf Bakterien und auf den thierischen Organismus. *Zeitsch. Hyg.* **6**: 312-368. 1889.
127. REICHEL, H. C. Elektrisch-magnetische Wirkungen. *Licht. Handb. Path. Mikroorg.* **3**: 867-986. 1929.
128. REITZ, A. Untersuchungen mit photodynamischen Stoffen. *Central. Bakt. und Parasitenk. Abt. 1.* **45**: 270-285, 451-466. 1908.
129. RICHARDSON, A. The action of light in preventing putrefactive decomposition; and in inducing the formation of hydrogen peroxide in organic liquids. *Jour. Chem. Soc. [London]* **63**: 1109-1130. 1893.
130. RIEDER, H. Wirkung der Röntgen Strahlen auf Bakterien. *Münch. Med. Wochensch.* **45**: 101-104. 1898. (*See also Ibid.* **45**: 773-774. 1898; **49**: 402-410. 1902.)
131. RISLER, J., A. PHILBERT, and J. COURTIER. Action photobiologique des rayonnements. *Compt. Rend. Acad. Sci. [Paris]* **186**: 1152-1154. 1928.
132. ROTHERMUNDT, M. Ueber das Verhalten der Bakterien an der Oberfläche fließender Gewässer. *Arch. Hyg.* **65**: 149-180. 1908.
133. ROUX, E. De l'action de la lumière et de l'air sur les spores de la bactérie du charbon. *Ann. Inst. Pasteur* **1**: 445-452. 1887.
134. RUSS, V. K. Einiges über den Einfluss der Röntgenstrahlen auf Mikroorganismen. *Arch. Hyg.* **56**: 341-360. 1906.
135. SALVIOLI, G. L'azione di alcune sostanze fluorescenti sulle spore del carbonchio e di altri bacteri sporigeni. *Sperimentale, Arch. di Biol.* **76**: 169-187. 1922.
136. SCHERTZ, A. Die Wirkung der ultravioletten Strahlen auf die Lebensverhältnisse der Bodenbakterien. *Arch. Mikrobiol.* **1**: 577-598. 1930.
137. SCHROETER. Beiträge zur Frage der Sterilisation von Trinkwasser mittels ultravioletter Strahlen. *Zeitsch. Hyg.* **72**: 189-212. 1912.
138. SCHWARZ, L., and AUMANN. Ueber Trinkwasserbehandlung mit ultravioletten Strahlen. *Zeitsch. Hyg.* **69**: 1-16, 68-91. 1911. (*See also Ibid.* **73**: 119-142. 1912.)
139. SCHWARTZ, F. K. T., and O. SCHELLENBERG. Die biologische und bakterizide Wirkung des Phosphoreszenzlichtes. *Centralbl. Bakt. und Parasitenk. Abt. 1.* **116**: 122-131. 1930.
140. SKURSKY, J. Ueber den Einfluss des Ultraviolettlites auf die keimtötende Kraft entzündlicher Ergüsse. *Wiener Klin. Wochensch.* 1929. 1351-1352.

141. SOLIGNAC, G. Études sur la photosensibilisation chez les bactéries. *Rev. Actiol.* **5**: 556-588. 1929.
142. SONNE, C. Die Abhängigkeit der lichtbiologischen Reaktionen von der Wellenlänge. *Strahlentherapie* **28**: 45-51. 1928. (*See also* *Arch. Phys. Ther.* **10**: 239-252. 1929.)
143. SPENCER, R. R. The sensitivity, in vitro, of bacteria to the beta and gamma rays of radium. U.S. Treas. Dept., Publ. Health Rept. **49**: 183-192. 1934.
144. STENSTROM, W., and J. B. GAIDA. Action of ultra-violet rays on new and old bacterial cultures. *Proc. Soc. Exp. Biol. and Med.* **38**: 898-902. 1931.
145. STRAUS, I. Note sur l'action de la lumière solaire sur les spores du *Bacillus anthracis*. *Compt. Rend. Soc. Biol. [Paris]* **38**: 473-474. 1886.
146. STREBEL, H. Untersuchungen über die bakterizide Wirkung des Hochspannungsfunkenlichtes. *Deut. Med. Wochenschr.* **27**: 69-72. 1901.
147. TAPPEINER, H. VON, and A. JODLBAUER. Die sensibilisierende Wirkung fluoreszierender Substanzen. 210 p. Vogel; Leipzig, 1907.
148. THIELE, H., and K. WOLF. Ueber die Abtötung von Bakterien durch Licht. *Arch. Hyg.* **57**: 29-55. 1906. (*See also* *Ibid.* **60**: 29-30. 1907.)
149. TIZZONI, GUIDO, and GIUSEPPINA CATTANI. Ueber die Widerstandsfähigkeit der Tetanusbazillen gegen physikalische und chemische Einwirkungen. *Arch. Exp. Path.* **28**: 41-60. 1891.
150. TRESKINSKAJA, A. Ueber den Einfluss des Sonnenlichtes auf Tuberkelbazillen. *Centralbl. Bakt. und Parasitenk. Abt. 1.* **47**: 681-695. 1910.
151. VAN DER LINGEN, J. S. Ueber die bakterientötende Wirkung des sichtbaren Spektrums. *Zeitsch. Hyg.* **101**: 437-441. 1923.
152. VLÉS, F. Recherches sur quelques propriétés optiques des suspensions biologiques et leur application à l'opacimétrie bactérienne. *Arch. Phys. Biol.* **1**: 189-299. 1921-24.
153. VOOGT, J. D. DE. Untersuchungen über die bakterizide Wirkung der ultravioletten Strahlen. *Zeitsch. Hyg. und Infektionskr.* **81**: 63-68. 1916.
154. WARBURG, O. Sauerstoffübertragende Fermente. *Naturwiss.* **22**: 441-446. 1934.
155. WARD, H. M. Further experiments on the action of light on *Bacillus anthracis*, and on the bacteria of the Thames. *Proc. Roy. Soc. [London]* **56**: 315-395. 1894. (*See also* *Ibid.* **5**: 472-475. 1893; **53**: 23-44. 1893; **52**: 393-400. 1893; **51**: 183-279. 1892.)
156. WARD, H. M. The action of light on bacteria. III. *Phil. Trans. Roy. Soc. [London] B.* **185**: 961-986. 1894.
157. WEINSTEIN, I. Quantitative biological effects of monochromatic ultra-violet light. *Jour. Opt. Soc. Amer.* **20**: 433-456. 1930.
158. WELCH, H., and R. G. PERKINS. The absorption of bactericidal ultra-violet light by screens of known visual opacity. *Jour. Prev. Med.* **4**: 15-26. 1930.
159. WESBROOK, F. F. The growth of cholera (and other) bacilli in direct sunlight. *Jour. Path. and Bact.* **3**: 352-358. 1896. (*See also* *Ibid.* **3**: 70-77.)
160. WIESNER, R. Die Wirkung des Sonnenlichtes auf pathogene Bakterien. *Arch. Hyg.* **61**: 1-95. 1907.
161. WILKES-WEISS, DOROTHY, and C. WEISS. Ultra-violet rays in the purification of cultures of *Spirochaeta pallida*. *Proc. Soc. Exp. Biol. and Med.* **23**: 87-91. 1925.
162. WINTERSTEIN, O. Lichtwirkung auf Bakterien. *Strahlentherapie* **39**: 619-642. 1931.
163. WITTLIN, J. Haben die Röntgenschen Strahlen irgendwelche Einwirkung auf Bakterien? *Centralbl. Bakt. Abt. 2.* **2**: 676-677. 1896.

164. WYCKOFF, R. W. G. The killing of certain bacteria by x-rays. *Jour. Exp. Med.* **52**: 435-446. 1930.
165. WYCKOFF, R. W. G. The killing of colon bacilli by X-rays of different wave lengths. *Jour. Exp. Med.* **52**: 769-780. 1930.
166. WYCKOFF, R. W. G. The killing of colon bacilli by ultraviolet light. *Jour. Gen. Physiol.* **15**: 351-361. 1932.
167. WYCKOFF, R. W. G., and T. M. RIVERS. The effect of cathode rays upon certain bacteria. *Jour. Exp. Med.* **51**: 921-932. 1930. (*See also Proc. Soc. Exp. Biol. and Med.* **27**: 312-314. 1930.)

Manuscript received by the editor May, 1935.

XXXVII

THE EFFECTS OF RADIATION ON ENZYMES

HAROLD A. SCHOMER

Department of Botany, University of Wisconsin

The study of the relation of light to enzymes may be divided into two parts: (a) the use of light in the study of the structure of enzymes, mainly their absorption spectra, and (b) the possible effects of the absorbed radiation on the enzymes. Since the greatest progress in the purification of enzymes and in the perfection of physical apparatus in the field of radiation has been made in comparatively recent years, early work on irradiation of enzymes was necessarily rather crude and qualitative.

In 1879 Downes and Blunt (19) found that invertase ("zymase" from a fragment of yeast macerated in water and filtered) was inactivated by the full solar spectrum in the presence of oxygen. They concluded that the chief injury was due to the blue-violet portion, and that the inactivation was an oxidation reaction. Fermi and Pernossi (23) studied the effect of sunlight and temperature, together with various acids and salts, on various enzymes, the sources of which are not described. Pepsin and trypsin were found to be inactivated by long exposure (10 days) to sunlight. It was also reported that greater inactivation by light occurred at higher temperatures (54° to 56°C.), than at lower temperatures (37°C.). When exposed in the dry condition, these enzymes retained their activity over long periods of time (3 months). Similar results were obtained with ptyalin, diastase, and emulsin in the dry state, and in the presence of chloroform, ether, amyl alcohol, or benzol. Bacteria, exposed to sunlight, lost considerable of their proteolytic activity.

Green (30) made extensive studies on the action of sunlight and light from an electric arc upon malt diastase solution, diastase in leaf tissue, and upon human saliva. Over a 24-hr. period, bright sunlight had no effect, while diffused light was found to increase slightly diastatic activity. After an exposure of 10 days the diastatic activity decreased 93 per cent. The various diastase solutions were also exposed to an electric arc of 2000 candle power at a distance of 2 ft. for 10-, 12-, and 24-hr. periods. Exposures were made in open Petri dishes, the enzyme solutions being mixed to a gel with agar, then disposed in quartz vessels and in glass vessels. The entire spectrum was found to exert an attenuating influence on the diastatic activity; visible and infra-red rays (passed through glass)

produced first an increase followed by a decrease in activity. He concludes, therefore, that the destructive rays are in the ultra-violet region, while radiation in the red and blue regions has the power of increasing the diastatic activity; this last he explained by assuming the conversion of zymogen into the active enzyme by those wave-lengths. Similar results were obtained with living leaf tissue, except that the effects were less marked. Green attributes this fact to the protective action of chlorophyll and of proteins of the protoplasm against the destructive ultra-violet rays.

Emmerling (21) likewise studied the effect of sunlight upon a number of crude enzyme preparations but failed to obtain uniform results. Pronounced inactivation occurred with rennet and maltase upon an exposure of 6 hr. to direct sunlight, but little or no inactivation occurred upon similar exposures of invertase, lactase, emulsin, amylase, trypsin, and pepsin. Von Tappeiner (82) studied the effects of sunlight upon enzymes with and without addition of fluorescing dye substances, and he found that there was little or no effect upon diastase, invertase, and papain when exposure was made without a fluorescing substance. But when such a substance was added, even in so dilute a concentration as 1:1,000,000, definite attenuation of enzyme activity resulted. In confirmation of these results, Jodlbauer and von Tappeiner (42) exposed solutions of invertase to sunlight with and without ultra-violet rays, and found that the sunlight without the ultra-violet was capable of producing little injury. This injury, however, was increased to 80 per cent in 10 min. if a small amount of fluorescing material was added. The same authors later (86), using a carbon arc, irradiated solutions of invertase in a water bath to exclude infra-red rays and found definite injury from the irradiation wholly unrelated to the presence of oxygen of the air.

Chauchard and Mazoué (14) irradiated solutions of malt amylase and yeast invertase separately and together, using as a light source a 110-v. mercury-vapor lamp. The enzyme solutions were commercial malt extract and invertase prepared from beer yeast, filtered until clear (details of preparation not given). They were exposed in quartz tubes, fastened to the circumference of a wheel rotating around the lamp at a distance of 12 cm. Activity of both enzymes was diminished, but the malt amylase was found to be much more sensitive to the ultra-violet rays than the yeast invertase. Svanberg (80) using for the first time highly purified invertase solution found its activity to be easily destroyed by ultra-violet light, the destructive effect being considerably greater with increasing purity of the preparation. These results are confirmed by Gorbach and Pick (29) who report that yeast autolysates were scarcely injured by irradiation of 2 hr., while preparations of a high degree of purity lost their activity after 20 to 30 min. The hydrogen ion concentration was found to be of slight effect on the degree of inactivation, espe-

cially of the purest invertase preparations. Inactivation by ultra-violet rays was very pronounced in the presence of ozone. In the presence of molecular oxygen, 10 min. of irradiation caused activation of invertase. This was explained by assuming that the oxygen, activated by ultra-violet rays, oxidized the activity-restraining substances accompanying the enzyme, making the latter harmless. In this work a quartz-mercury lamp was used directly for the radiation studies, and there was room for refinement of technique.

Gorbach and Lerch (28) irradiated thin layers of invertase solutions of varying degrees of purity in flat dishes, with a mercury-vapor lamp and light filters. The irradiation dishes were placed in a vessel of ice water to prevent heating and evaporation of the enzyme solution. The absorption spectra of all enzyme solutions showed, independent of their degree of purity, an absorption band at 2700 \AA . Sharpness of the band increases with the degree of purity of the enzymic preparation. Absorption was not measurably changed when the enzyme was first rendered inactive by ultra-violet irradiation. Pure tryptophane was found to absorb at 2700 \AA , and an increase in the tryptophane, which was present in the purest enzyme preparations, increased the enzyme activity. The investigators conclude that tryptophane is the carrier for the enzyme-active group, and inactivation of the invertase might be explained, in the case of their experiment, as a disturbance of tryptophane as a usable carrier. The absorption spectra were taken with a Zeiss spectrograph (Scheibe method). Gorbach and Kimovec (27) found that invertase solutions of definite purity which have been irradiated for 10 min. and longer lose their residual activity upon subsequent standing, while enzyme solutions irradiated for a shorter time are stable. No reactivation was obtained by the addition of tryptophane or yeast gums; on the contrary, post-inactivation was hastened, yeast gums acting more powerfully than tryptophane.

Agulhon (1, 1a, 2) studied the effects of radiations from a mercury arc upon a number of commercial and crude enzymes, *i.e.*, invertase, malt and pancreatic amylases, emulsin, pepsin, rennet, catalase, laccase, and tyrosinase. An Heräus mercury-vapor lamp in fused quartz, using 2 to 3 amp. on 110 v., was used as the radiation source, and the enzyme solutions were exposed at distances of 15 to 20 cm. both in quartz and in glass test tubes, the glass being sufficiently thick to check radiations shorter than 3022 \AA . After exposures ranging from 30 min. to 6.5 hr., the activity of all of these enzymes suffered some degree of attenuation from wave-lengths shut out by glass but transmitted by quartz. Some deleterious effect of visible rays was noted on emulsin and catalase, but visible light appeared to have no effect upon the other enzymes. In general, the injury appeared to be due to the ultra-violet, with radiations longer than $\lambda 3022 \text{ \AA}$ having no effect. Considering the mechanism of

destruction, Agulhon (1a) suggests three groups: (a) invertase, laccase, and tyrosinase, destroyed by visible light only when oxygen is present and by ultra-violet more rapidly when oxygen is present; (b) catalase and emulsin, inactivated in a vacuum by both visible and ultra-violet radiation; and (c) rennet, destroyed by ultra-violet in the presence or absence of oxygen. The interaction of foreign substances in these effects is recognized as a possibility.

Chauchard (12) made a quantitative study of the action of monochromatic ultra-violet light on amylase of *Aspergillus* (details of preparation of enzyme are not given). Sparks between electrodes of Mg, Cd, and Zn were used as light sources, filters being used in one case to isolate the various wave-lengths, the enzyme preparation being exposed as a suspension 7 mm. in depth in a quartz cell placed 4 cm. from the light source. In a second part of the experiment the light was separated into monochromatic radiations by two quartz prisms. There was no mention of temperature control. The energy of each wave-length was measured with a "Ruben's battery," wave-lengths ranging from 2144 to 3600 Å being employed. Absorption studies were made for several wave-lengths. It was concluded that the photochemical action is proportionate to the absorption of the suspension, and absorption varies inversely with the wave-length, the greatest absorption being 99.96 per cent at $\lambda 2307$ Å (the shortest wave-length employed in the absorption studies). Amylase was destroyed only by radiation of less than 2800 Å, the action increasing very rapidly as the wave-length decreases, while lipase was destroyed even by radiations of $\lambda 3300$ Å, with shorter wave-lengths increasingly efficient in the inactivation. There seemed to be no relation between the absorption spectrum of pancreas extract, which has a maximum absorption at 2813 Å, and the destruction spectra of amylase and lipase.

In 1923, Ludwig Pincussen began the publication of a series of papers entitled "Fermente und Licht" which reported a number of experiments conducted by him and his associates upon the subject. Reference can be made here and in later paragraphs to only a limited number of the observations reported. Using malt diastase, the full spectrum of the mercury arc produced strong inactivation, the action depending upon such conditions as the concentration of the solution, on accompanying compounds, and on the reaction of the medium (67a). The greatest effect occurred at the optimum reaction for enzyme activity. Using later (67d) the same enzyme and the same source of radiation, the reaction constant was calculated at various hydrogen ion concentrations. With increased exposure, the reaction constant decreased. The inactivation constant was also calculated from digestion experiments with various concentrations of starch at different hydrogen ion concentrations. Inactivation was found to follow the course of a monomolecular reaction, with maximum decrease in the reaction constants at pH 6.26. Taka

diastase proved to be more easily inactivated (67*f*) by ultra-violet radiation than the malt diastase preparations employed, and in the former case the addition of certain salts, especially salts of iodine, decreased the amount of injury. Pancreatic diastase and ptyalin were protected by KI, but not malt diastase (67*e*).

With malt diastase the protective action of NaCl was least at pH 6.64 (67*e*). Small quantities of other salts showed greater protective action than larger amounts. In general (67*j*) there is a protective action of the chlorides of K, Ca, Mg, Li, and Pb, the order of the protection varying with the different diastases and also with the concentration of the salts and of the enzyme solutions. Usually the K salts offered the least protection, and Ca salts the greatest.

It was also found (67*m*) that certain sensitizers (eosin, sodium dichloroanthracene disulfonate, and sodium anthraquinone disulfonate) as well as certain impurities present in the enzyme solutions exert a protective action on the enzyme. The greatest inactivation occurred at the optimum pH for digestion, with or without the addition of the sensitizers. The lecithase and phosphatase in a Taka diastase preparation were irradiated with the mercury-vapor arc (67*o*), and at pH 6.6 phosphatase was much more seriously inactivated by ultra-violet light than was lecithase. The course of inactivation followed the law for a reaction of the first order. Greater inactivation of Taka diastase by ultra-violet light occurs at pH 5.91–5.97 (67*n*), which also is its activity optimum. Heat resistance is greatest at alkaline reactions. Ultra-violet combined with heat (45° to 50°C.) is most powerful at pH 4.83 to 4.89. Heat and ultra-violet destructions are thus assumed to have different mechanisms.

Terroine and Bonnet (88) found that diastase of the pancreatic juice of a dog and that of the gastroenteric juice of a snail (*Helix pomatia*) are more sensitive to the destructive action of ultra-violet rays when they are exposed in the presence of NaCl than when exposed in their inactive forms (obtained by prolonged dialysis). The variations of sensitivity to ultra-violet radiation and heat rays of the active and inactive diastases were neither general nor regular.

Thompson and Hussey (89) irradiated a diastase solution prepared from pancreatin in 0.85 per cent saline. The enzyme was irradiated in a flat bottomed cylindrical quartz tube placed vertically above a quartz window, and in the bottom of a thermo-regulated water bath at 10°C. The quartz-mercury lamp employed was 19 cm. below the quartz window. The enzyme solution was stirred during the experiment, and a control in a light-screened container was held in the same bath. Apparently no attempt was made to measure light intensity or quality. The diastase in solution was inactivated by the radiations, and the reaction course was that of a monomolecular reaction. The reaction was followed to a

point where more than 88 per cent change had taken place, and it was due apparently "to the influence of the ultra-violet radiation alone."

Fuller (24, 24a) irradiated solutions of Taka diastase and Difco invertase for 30 min. periods in open Petri dishes at a distance of 10 in. from a quartz-mercury-vapor arc. Experiments were also made with the infra-red present and with these rays screened out incompletely by a quartz cell with 1.5 cm. water. Intensity measurements of the light source were made with a thermopile and galvanometer, but absorption of the enzyme solutions was not determined. The attempt was also made to study the effects of radiation on enzymes in living plants. The tissue extracts of the irradiated and nonirradiated plants were then tested for enzyme activity. The Taka diastase and Difco invertase suffered partial inactivation when irradiated in vitro with ultra-violet and infra-red light, but in the living plant such was not the case. In the living plant, with the intensities used, the activity of the four enzymes was apparently increased, although the plants were severely injured, and it should be observed that the control plants were not strictly "control." Mycelium of a *Fusarium* was killed by similar irradiation, but the activity of its amylase and peptase was slightly increased. Fuller concludes that injury of living tissue by irradiation is due to some other factor than the inactivation of these enzymes. Increased activity of the blood diastase and of catalase of irradiated young dogs was reported by Karapetjan (44), but this indirect effect did not extend to lipase.

Hutchinson and Ashton (38) determined the effects of full radiation from a mercury-vapor arc and also individual wave-lengths as transmitted by a monochromatic illuminator on the diastases of saliva and of malt. Full irradiation retarded the dextrinogenic and saccharogenic activity of both salivary and malt diastase in an inverse relation to light intensity. In the case of salivary diastase, they report the rates of dextrin production and of maltose production decreased by the green and the far ultra-violet, while there was apparently stimulation with the red-yellow and the near-ultra-violet wave-lengths. On malt diastase monochromatic radiation was generally inhibitory for the dextrinogenic phase and stimulatory for the saccharogenic phase. These results may be explained by the presence of two enzymes constituting the diastase, one dextrinogenic, the other saccharogenic; either may be the less active and so become the "pace setter" for maltose production. In salivary diastase the dextrinogenic enzyme is the pace setter, while in malt diastase the saccharogenic enzyme is usually the pace setter; full illumination, however, retards the dextrinogenic enzyme until it becomes the pace setter.

Pincussen and Hayashi (67l) exposed serum lipase from rabbits and guinea pigs to a quartz-mercury-vapor arc, and found that definite injury occurred at acid pH values, but the injury was practically nil at alkaline pH values.

Peroxidase activity declines upon exposure to light, as is evidenced by the work of a number of investigators. Jamada and Jodlbauer (39) and Zeller and Jodlbauer (94) found that peroxidase and catalase were sensitive to ultra-violet and visible radiations. Visible light was active only if oxygen was present, while ultra-violet was active in the absence of oxygen as well as in its presence. Photodynamic substances were found to speed up the inactivation in visible light. Bach (4) noted a decline in its activity when exposed to sunlight in an Erlenmeyer flask. Reinle (72) exposed milk to ultra-violet light and found a harmful effect on the peroxidase only after prolonged exposure. Pincussen and Hammerich (67s), preparing a peroxidase from the horse radish according to methods described by Willstätter and Oppenheimer, found that this enzyme was damaged by the light from a mercury-vapor arc. The hydrogen ion concentration appeared to have little effect upon the action exerted by the ultra-violet. Decrease in activity of the peroxidase was found to be roughly proportional to the intensity of the light.

Tallaricio (81) and Batelli and Stern (5) reported destruction of catalase activity by sunlight, the former investigator stating that red light conserves the activity while blue light decreases the activity. Batelli and Stern found that the O_2 factor is unimportant in the destruction of catalase. Waentig and Steche (91) found that the effect of light, especially ultra-violet, on catalase is more pronounced in an alkaline solution than in a neutral or acid one. Pincussen and Seligsohn (67h) found that blood catalase in an impure condition follows the same rules that were found for other enzymes investigated by them. At pH 6 to 8 the inactivation of catalase by ultra-violet is a function of irradiation time, as reported by Morgulis (57). Stern (79) found that irradiation of liver catalase with wave-lengths of 3000 to 4000 Å has no effect, but the entire light of the mercury-vapor lamp retarded its activity.

Studies on the effect of radiation on crude urease from soy bean have been reported (67b, 67c), but the later work of Tauber (87) was on crystalline urease (after Sumner). Tauber found that direct sunlight did not affect urease to which no eosin had been added at the various temperatures and time intervals studied. In the presence of eosin, sunlight was inactivating, while ultra-violet had an inhibitory effect upon the activity inversely proportional to the distance from the radiation source, and intensified by the presence of eosin.

From the large number of experiments cited before, it may be seen that in most of the studies little attempt has been made to place the work entirely upon a quantitative basis. Many difficulties necessarily have confronted the investigator, and the more precise earlier work, such as that of Chauchard, was handicapped by the use of crude enzyme preparations, even though nearly monochromatic radiation was employed and energies carefully measured. In a large number of the experiments, no

attempt was made to segregate the effective rays of the ultra-violet or to determine their intensity and the amount of absorption responsible for the effect produced. Too often no attempt was made to control experimental conditions, such as temperature, hydrogen ion concentration, evaporation, etc.

The preparation of crystalline enzymes as reported by Sumner and by Northrop naturally removed a great obstacle in studying enzyme chemistry. Previously, although very active enzymic preparations were made, there was always the question of the role that unknown impurities

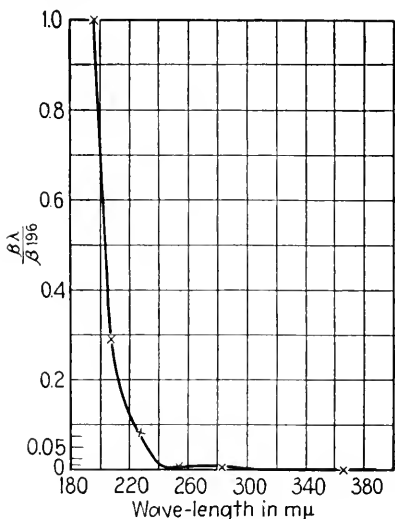

FIG. 1.—The outlined curve shows the absorption spectrum of urease as directly measured, the crosses designating the points where the absorption has been calculated from the inactivation measurements. (After Kubowitz and Haas, *Biochem. Zeitsch.* 257: 337-343. 1933.)

played in producing various experimental results. In irradiation, the question of protective action and absorption by these impurities is a very important one, and might appreciably modify the results obtained from an impure preparation. However, the question of the crystalline nature of enzymes has not yet been proved to the satisfaction of all investigators. In any case, great strides have been made in the preparation of more active enzymes and in purification procedures.

Kubowitz and Haas (50), at Warburg's suggestion, determined the absorption spectrum and destruction curve of purified urease. They were unable to prepare crystals, but they obtained just as active a preparation as that reported by Sumner. Light sources used were a mercury-arc lamp

and various metallic spark sources. A monochromator served to split up the light with fluorspar or quartz optics, and the intensity of each wave-length employed, ranging from 1960 to 3660 Å, was measured by means of a bolometer. The curve of the absorption spectrum of the urease coincided with the curve of the destruction of the enzyme, there being a slight destruction of urease activity at 2650 Å, with a very rapid destruction by wave-lengths shorter than 2500 Å (see Fig. 1).

Hussey and Thompson (36) irradiated a pepsin solution made from granular pepsin dissolved in water acidified to pH 4.4. with 0.1 M HCl for periods of 1, 2, 3, and 4 hr., with a quartz-mercury-vapor lamp. (The experimental arrangements were as previously described for Thompson and Hussey, 89.) The enzyme was inactivated by the irradiation, and they concluded that the effective radiations were those of the ultra-

violet region of the spectrum, and that the process was that of a monomolecular change. The maximum light inactivation of pepsin occurs at the pH of maximum activity, *i.e.*, at 1.15, as found by Pincussen and Uehara (67*k*). At pH 1.93 and 2.28 there was no significant difference between the activities of rayed and unrayed solutions. Calvin (11) reported a decrease in the activity of pepsin and trypsin due to the effect of radiations from a mercury-vapor lamp. Temperature and other factors were controlled. Pace (1931) studied the effects of radiation from a mercury-vapor arc upon solutions of trypsin and enterokinase which had been previously partially inactivated by heat. Upon irradiation by light around 2800 Å, only further inactivation occurred; with visible light only, there was no further effect upon the enzymes. Inactivation was greater if the entire radiation of the quartz lamp was used.

Northrop (61) irradiated dilute solutions of crystalline pepsin, buffered at pH 4.65, in quartz tubes (the controls being glass tubes), using a General Electric "Lab Arc" lamp as the light source, at a distance of 8.5 cm. The determination indicated a loss in activity of the pepsin, accompanied by a corresponding decrease in the total protein nitrogen of the solution, the latter suggesting the protein nature of the enzyme preparation. The rate of inactivation was dependent upon pH, and was a maximum at about pH 2.0. There was no change in activity or in protein nitrogen in the controls, from which ultra-violet was largely screened out.

Gates (26) studied the absorption and destruction spectra of solutions of Northrop's crystalline pepsin in the ultra-violet region. Petri dishes covered with cellophane and with glass, respectively, served as exposure and control vessels. The apparatus used included an air-cooled horizontal quartz-mercury-vapor lamp, a large quartz monochromator, thermopile, and galvanometer. The lamp was operated at 67 v. and 5.5 amp. Samples were exposed at 30 cm. at temperatures of 20° and 22°C. At intervals, from 20 to 360 min., 5-ml. samples were removed for activity and for absorption tests. Total absorption in the ultra-violet region increased with the degree of inactivation, this increase being especially marked between λ 2400 and 2750 Å. The rate of inactivation was sensitive to changes in pH, increasing with lower values, and apparently bearing a one-quantum relationship to the energy flux. The destruction spectrum of the enzyme was found to agree essentially with its absorption spectrum and is similar to that of urease, as found by Kubowitz and Haas (50).

Tyrosinase activity in two substrates, according to experiments of Pincussen and Hammerich (67*r*), was easily destroyed by radiations from a quartz-mercury-vapor arc. However, in the irradiation of *Dolichos* tyrosinase, described by Narayanamurti and Ramaswami (59), irradiation accelerated activity; but about one-half of this increased activity was

lost within 1 hr. after irradiation. Pancreatin activity is also attenuated by the action of ultra-violet radiation (Pincussen and Klissimus, 67g); but this enzyme is much more light-resistant in the presence of salts of iodine (other salts are less active).

A few other qualitative studies on miscellaneous enzymes may be mentioned. Emulsin, milk aldehydase, and succino-dehydrogenase each suffered partial inactivation upon irradiation with ultra-violet from a mercury-vapor arc. The destruction of activity of emulsin was found by Helferich and Brieger (33) to be differential, depending upon whether emulsin is tested against β -*d* glucoside or α -*d* mannoside. Pincussen and Oya (67n, 67o) found inactivation of milk aldehydase by ultra-violet in the presence of oxygen at the optimal pH of 7.35, while Pincussen and Roman (67q) reported that an irradiation of 15 min. injured succino-dehydrogenase of horse muscle to the same extent as irradiation of 1 hr. with visible light.

The above review attempts to describe representative work on the effects of radiation on enzymes, giving consideration, where possible, to the several groups of enzymes and to the historical aspect. There are, unfortunately, very few articles, which, while presenting a systematic study of the effects of radiation on enzymes, at the same time take advantage of the modern developments in radiation technique and of the best methods of enzyme purification. The value of future work in this field will be enhanced by consideration of these advances and by giving strict attention to all conditions or modifying factors.

REFERENCES

1. AGULHON, H. Action des rayons ultraviolets sur les diastases. *Compt. Rend. Acad. Sci. [Paris]* **152**: 398-401. 1911. (*See also* *Ibid.* (a) **153**: 979-982. 1911.)
2. AGULHON, H. Action de la lumière sur les diastases. *Ann. Inst. Pasteur* **26**: 38-47. 1912.
3. ALVERSENG, J. P., L. JALOUSTRE, and E. MAURIN. Sur quelques actions du thorium sur les diastases et les microbes. *Compt. Rend. Acad. Sci. [Paris]* **176**: 193-195. 1923.
4. BACH, A. Über das Verhalten der Peroxidase gegen Licht. *Ber. deut. chem. Ges.* **41**: (1): 225. 1908.
5. BATELLI, F., and L. STERN. Action de la lumière sur la catalase. *Compt. Rend. Soc. Biol. [Paris]* **68**: 1040. 1910.
6. BERGELL, P., and A. BRAUNSTEIN. Ueber den Einfluss der Radiumsalze auf den fermentativen Eiweissabbau. *Med. Klin.* **1**: 310-314. 1905.
7. BERING, F., and H. MEYER. Experimentelle Studien über die Wirkung des Lichtes. Untersuchung über die Wirkung auf die Oxydationsfermente. Wirkung der verschiedenen Strahlengruppen und ihre Sensibilisierung. *Strahlentherapie* **1**: 411-437. 1912.
8. BICKEL, A., and D. MINAMI. Ueber die biologische Wirkung des Mesothorium. *I. Ber. Klin. Wochensh.* **48**: 1413. 1911.
9. BROWN, F. R. The influence of radium and of its decomposition products on the ferments. *Arch. Internat. Med.* **10**: 405-413. 1912.

10. BURGE, W. E., W. R. FISCHER, and A. J. NEILL. The destruction of hormones, proenzymes, and enzymes by ultra-violet radiation. *Amer. Jour. Physiol.* **40**: 426-432. 1916.
11. CALVIN, D. B. The effect of irradiation by the Hg-vapor arc on the activity of pepsin and trypsin. *Amer. Jour. Physiol.* **93**: 639. 1930.
12. CHAUCHARD, A. Étude quantitative de l'action des rayons ultraviolets monochromatiques sur l'amylase. *Compt. Rend. Acad. Sci. [Paris]* **166**: 1858-1860. 1913.
13. CHAUCHARD, A., and MME. CHAUCHARD. Action des rayons ultraviolets monochromatiques sur l'amylase et la lipase du suc pancréatique. *Compt. Rend. Acad. Sci. [Paris]* **158**: 1575-1577. 1914.
14. CHAUCHARD, A., and MME. B. MAZOUÉ. Action des rayons ultraviolets sur l'amylase, l'invertine, et le mélange de ces deux diastases. *Compt. Rend. Acad. Sci. [Paris]* **152**: 1709. 1911.
15. CLARK, HARRY, and J. H. NORTHROP. The inactivation of trypsin by X-rays. *Jour. Gen. Physiol.* **9**: 87-96. 1925.
16. CLAUS, G. Über die Dunkelwirkung fluoreszierender Farbstoffe auf Diastase. *Biochem. Zeitsch.* **204**: 456-466. 1929.
17. COLLIER, H. BRUCE, and HARDOLPH WASTENEYS. The action of radiation on enzymes. *Austral. Jour. Exp. Biol. and Med. Sci. (Robertson Mem. Vol.)* **9**: 89-112. 1932.
18. CREMER, W. Über eine Kohlenoxydverbindung des Ferrocysteins und ihr Spaltung durch Licht. *Biochem. Zeitsch.* **194**: 231-232. 1928.
19. DOWNES, A., and T. P. BLUNT. On the influence of light upon protoplasm. *Proc. Roy. Soc. [London]. IV.* **28**: 199-212. 1879.
20. DREYER, G., and O. HANSEN. Recherches sur les lois de l'action de la lumière sur les glycosides, les enzymes, les toxins, les anticorps. *Compt. Rend. Acad. Sci. [Paris]* **145**: 564-566. 1907.
21. EMMERLING, O. Die Einwirkung des Sonnenlichts auf die Enzyme. *Ber. Deut. Chem. Ges.* **34**(III): 3811-3814. 1901.
22. EULER, H. VON, and I. LAURIN. Verstärkung der Katalasewirkung in Hefezellen. *Zeitsch. Physiol. Chem.* **106**: 312-316. 1918.
23. FERMI, C., and L. PERNOSI. Ueber die Enzyme. *Zeitsch. Hyg. und Infektionskr.* **18**: 83-127. 1894.
24. FULLER, HARRY J. Some effects of radiations from a mercury vapor arc in quartz upon enzymes. *Annals Missouri Bot. Gard.* **19**: 505-531. 1932. (*See also Ibid.* **19**: 79-86.)
25. GASSUL, R., and A. POLAKOV. Über biochemische Röntgenstrahlenwirkung auf die proteolytischen und anderen Prozesse in vivo und in vitro. *Strahlentherapie* **30**: 519-536. 1928.
26. GATES, F. L. The absorption of ultra-violet radiation by crystalline pepsin. *Jour. Gen. Physiol.* **18**: 265-278. 1934. (*See also Ibid.* **18**: 279-282.)
27. GORBACH, G., and D. KIMOVEC. The post-inactivation of irradiated sucrase solutions and the influence of tryptophan and yeast gums. *Monatsch. Chemie* **61**: 39-46. 1932. (*Cf. Chem. Abst.* **24**: 1875. 2769.)
28. GORBACH, G., and K. LERCH. Über den Einfluss des ultravioletten Lichtes auf die Saccharase. I, II. *Biochem. Zeitsch.* **219**: 122-135. 1930; (a) **236**: 259-266. 1931.
29. GORBACH, G., and H. PICK. Die Ultraviolet-Inaktivierung von Saccharase in ihrer Abhängigkeit von der Wasserstoffionenkonzentration und dem Ozon. *Sitzungsb. Akad. Wiss. Wien. Naturwiss. Kl. II b.* **141**: 397-406. 1932.
30. GREEN, J. REYNOLDS. On the action of light on diastase, and its biological significance. *Phil. Trans. Roy. Soc. [London]. IV. B* **188**: 167-190. 1897.

31. GUDZENT, F. Experimentelle Untersuchungen über die Beeinflussung von Fermenten durch radioaktive Substanzen. *Strahlentherapie* **4**: 666-673. (*See also Biochem. Zeitsch.* **17**: 667. 1914.)
32. HANNES, B., and A. JODLBAUER. Versuche über den Einfluss der Temperatur bei der photodynamischen Wirkung und der einfachen Lichtwirkung auf Invertase. *Biochem. Zeitsch.* **21**: 110-113. 1909.
33. HELFERICH, B., and G. BRIEGER. Über Emulsin XII. III. Die Schädigung von Emulsin durch ultraviolette Strahlen. *Hoppe Seyler's Zeitsch. Physiol. Chem.* **221**: 94-98. 1933.
34. HENRI, V., and A. MAYER. Action des radiation der radium sur les colloides, l'hémoglobine, les ferments, et les globules rouges. *Compt. Rend. Acad. Sci. [Paris]* **138**: 521-524. 1904. (*See also Compt. Rend. Soc. Biol. [Paris]* **56**: 230-232. 1904.)
35. HUSSEY, R. G., and W. R. THOMPSON. The effect of radioactive radiations and X-rays on enzymes. *Jour. Gen. Physiol.* **5**: 647-659. 1923.
36. HUSSEY, R. G., and W. R. THOMPSON. The effect of radiations from a mercury arc in quartz on enzymes. *Jour. Gen. Physiol.* **9**: 217-219. 1925.
37. HUSSEY, R. G., and W. R. THOMPSON. The effect of radioactive radiations and X-rays on enzymes. IV, V, VI. *Jour. Gen. Physiol.* **9**: 309-315. 1925; 309-313, 315-317. 1926.
38. HUTCHINSON, A. H., and M. R. ASHTON. The effect of radiant energy on diastase activity. *Canadian Jour. Res.* **9**(1): 49-64. 1933.
39. JAMADA, K., and A. JODLBAUER. Die Wirkung des Lichtes auf Peroxydase und ihre Sensibilisierung durch fluoreszierende Stoffe. *Biochem. Zeitsch.* **8**: 61-83. 1908.
40. JODLBAUER, A. Über die Wirkung photodynamischer Substanzen auf Paramaecium und Enzyme bei Röntgen- und Radiumbestrahlung. *Deutsch. Arch. Klin. Med.* **80**: 488-491. 1904.
41. JODLBAUER, A. Über den Einfluss des Sauerstoffes bei der Schädigung der Fermente (Invertin) durch Wärme. *Biochem. Zeitsch.* **3**: 483-487. 1907. (*See also Ibid.* pp. 488-502.)
42. JODLBAUER, A., and H. VON TAPPEINER. Über die Wirkung des ultravioletten Lichtes auf Enzyme (Invertin). *Deutsch. Arch. Klin. Med.* **87**: 373-388. 1906. (*See also Ibid.* **85**: 386-394. 1905.)
43. JUNGHAGEN, S. Über die Wirkung des ultravioletten Lichtes auf die Dehydrogenasen der Bernsteinsäure und der Glycerinphosphorsäure. *Skandinav. Arch. Physiol.* **54**: 115-119. 1928.
44. KARAPETJAN, O. K. Experimentelle Untersuchungen zur Frage des Einflusses der ultravioletten Strahlen auf die fermentativen Bluteigenschaften des wachsenden Organismus. *Zeitsch. Ges. Phys. Ther.* **45**: 8-17. 1933.
45. KEESER, E. Über die biologische Wirksamkeit des sichtbaren monochromatischen Lichtes. *Arch. Exp. Path. und Pharmakol.* **164**: 626-634. 1932.
46. KOEPPE, H. Licht und Katalase. *Strahlentherapie* **34**: 598-604. 1929. (*See also Arch. Kinderheilk.* **89**: 1-26. 1930.)
47. KOLDAJEW, B. M., and M. M. ALTSCHULLER. Über die Beeinflussung der Blutfermente durch Quarzlampe Licht. *Hoppe Seyler's Zeitsch. Physiol. Chem.* **186**: 223-228. 1930.
48. KÖRÖSKY, K. V. Radioaktivität und Fermentwirkung. *Pflüger's Arch. Physiol.* **137**: 123-143. 1910.
49. KRESTOWNIKOFF, A. Die Wirkung des Lichtes auf den Entfärbungsverlauf in einem Dehydrogenase-Methylenblausystem. *Skandinav. Arch. Physiol.* **52**: 199-208. 1927.

50. KUROWITZ, F., and E. HAAS. Über das Zerstörungsspektrum der Urease. *Biochem. Zeitsch.* **257**: 337-343. 1933. (*See also* *Naturwiss.* **20**: 469. 1932.)
51. LANGENDORFF, H., M. LANGENDORFF, and A. REUSS. Über die Wirkung von Röntgenstrahlen verschiedener Wellenlänge auf biologische Objekte. IV. *Strahlentherapie* **46**: 655-662. 1933.
52. LINDNER, P. Zur Wirkung ultravioletter Strahlen auf die alkoholische Gärung und auf Hefe. *Wochensch. Brauerei* **39**: 166-167. 1922.
53. LÖWENTHAL, S., and E. EDELSTEIN. Über die Beeinflussung der Autolyse durch Radiumemanation. *Biochem. Zeitsch.* **14**: 484-490. 1908.
54. LÖWENTHAL, S., and J. WOHLGEMUTH. Untersuchungen über die Diastasen. VIII. *Biochem. Zeitsch.* **21**: 476-483. 1909.
55. LUËRS, H., and P. LORINSER. Über die Hitze und Strahlungsinaktivierung der Malzamyase. *Biochem. Zeitsch.* **144**: 213-218. 1924.
56. MINAMI, D. Ueber die biologische Wirkung des Mesothorium. *Ber. Klin. Wochensch.* **48**: 1798-1800. 1911.
57. MORGULIS, S. (with the assistance of L. SHUMAKER). Studies on the inactivation of catalase. II. *Jour. Biol. Chem.* **86**: 75-85. 1930. (*See also* *Amer. Jour. Physiol.* **90**: 455. 1929.)
58. MORGULIS, S. Über die Inaktivierung der Katalase durch Ultraviolettbestrahlung bei verschiedenen Wasserstoffionenkonzentrationen. *Biochem. Zeitsch.* **221**: 29-32. 1930.
59. NARAYANAMURTI, DURAISWAMI, and C. V. RAMASWAMI. Irradiation of Dolichos tyrosinase. *Biochem. Jour.* **24**: 1655-1658. 1930.
60. NORRIS, R. J. An application of filtered ultra-violet radiation to sterilization of diastatic enzyme solutions. *Bull. Basic Sci. Res.* **2**: 93-104. 1928.
61. NORTHROP, J. H. Inactivation by beta and gamma rays from radium and by ultra violet light. *Jour. Gen. Physiol.* **17**: 359-363. 1934.
62. OPPENHEIMER, C. Die Fermente und ihre Wirkungen. 4 Aufl. Vogel; Leipzig, 1913.
63. PACE, J. Über die Wirkung von ultraviolettem und sichtbarem Licht auf durch Erhitzen inaktivierte Lösungen von Trypsin, Enterokinase und Trypsinkinase. *Biochem. Zeitsch.* **240**: 490. 1931.
64. PALLADIN, W. Die Arbeit der Atmungsenzyme der Pflanzen unter verschiedenen Verhältnissen. *Hoppe Seyler's Zeitsch. Physiol. Chem.* **47**: 407-451. 1906.
65. PEEMÖLLER, F., and H. FRANKE. Die Einwirkung ultravioletten Strahlen auf die Blütenkatalase. *Strahlentherapie* **21**: 165-170. 1926.
66. PFEIFFER, H., and G. BAYFR. Zur Kenntnis lichtkatalytischer Wirkungen. *Zeitsch. Exp. Med.* **14**: 137-219. 1921.
67. PINCUSSEN, L., ET AL. Fermente und Licht. I-XIX. (A series of articles by the author and various associates.) *Biochem. Zeitsch.* (a) **134**: 459-469. 1923; (b) **134**: 470-475. 1923; (c) **142**: 228-238. 1923; (d) **144**: 366-371. 1924; (e) **144**: 372-378. 1924; (f) **152**: 406-415. 1924; (g) **162**: 416-419. 1924; (h) **168**: 457-463. 1926; (i) **171**: 1. 1926; (j) **195**: 79-86. 1928; (k) **195**: 87-95. 1928; (l) **195**: 96-102. 1928; (m) **203**: 334-342. 1928; (n) **207**: 410-415. 1929; (o) **215**: 366-371, 398. 1929; (p) **215**: 398-401. 1929; (q) **229**: 281. 1930; (r) **239**: 273-289. 1931; (s) **241**: 384-391. 1931.
68. PINCUSSEN, L. Fermente und Licht. III. *Fermentforsch.* **8**: 181-186. 1925.
69. PINCUSSEN, L. Über Veränderungen des Fermentgehaltes des Blutes. III. *Biochem. Zeitsch.* **168**: 474-480. 1926.
70. PINCUSSEN, L., and J. ANAGNOSTU. Über die Beeinflussung der Fettspaltung durch Strahlung. *Biochem. Zeitsch.* **128**: 268-273. 1922.

71. POUGNET, J. Action des rayons ultraviolets sur les plantes coumarine et quelque plantes dont l'odeur provient de glucosides dédoublés. *Compt. Rend. Acad. Sci. [Paris]* **151**: 566-569. 1910. (*See also* *Ibid.* **152**: 1184-1186. 1911.)
72. REINLE, H. Über die Wirkung der Becquerel- und Röntgenstrahlen sowie des ultra-violetten Lichtes auf die Peroxydase und Methylenblau-Formalin-Reduktase-Reaktion der Kuhmilch. *Biochem. Zeitsch.* **115**: 1-21. 1921.
73. REVOLTELLA, G. Über eine Vereinfachung in der Herstellung eines Urease-trocken-Ferments, dessen Wirksamkeit und Eigenschaften. *Biochem. Zeitsch.* **134**: 336-348. 1923.
74. RICHARDS, A. The effect of X-rays on the action of certain enzymes. *Amer. Jour. Physiol.* **35**: 224-238. 1914.
75. SCHMIDT-NIELSEN, SIGVAL. Die Enzyme, namentlich das Chymosin, Chymosinogen, und Antichymosin, in ihrem Verhalten zu konzentriertem elektrischem Lichte. *Beitr. Chem. Physiol. und Path.* **5**: 355-376, 399. 1904. (*See also* *Ibid.* **5**: 175-176. 1905; **8**: 481-483. 1906.)
76. SCHMIDT-NIELSEN, SIGVAL. Die Wirkungen des konzentrierten elektrischen Bogenlichtes auf Chymosin, Chymosinogen, und Antichymosin. *Mitt. Fins. Med. Lysinst.* **9**: 199-232. 1905. (*See also* *Ibid.* **10**: 110-127. 1906.)
77. SCHMIDT-NIELSEN, SIGVAL. Quantitative Versuche über die Destruktion des Labs durch Licht. *Hoppe Seyler's Zeitsch. Physiol. Chem.* **58**: 232-254. 1909.
78. STASSANO, H., and L. LEMATTE. De la possibilité de conserver intactes les agglutinines dans les bactéries qu'on tué par les rayons ultraviolets. Advantage de ce moyen de stérilisation pour préparer les émulsions bactériennes destinées aux sérodiagnostics. *Compt. Rend. Acad. Sci. [Paris]* **152**: 623-624. 1911.
79. STERN, K. G. Über das optische Verhalten der Katalase. *Hoppe Seyler's Zeitsch. Physiol. Chem.* **212**: 207-214. 1932.
80. SVANBERG, O. Die Empfindlichkeit der Saccharase gegen ultraviolettes Licht und gegen Oxydationsmittel. *Ark. för Kemi, Min. o. Geol.* **8**: 1-17. 1921.
81. TALLARICIO, G. Comportamento della catalasi del fegato alle luci monochromatiche. *Arch. Farmacol. Sper.* **8**: 81-109. 1909.
82. TAPPEINER, H. VON. Über die Wirkung fluoreszierender Substanzen auf Fermente und Toxine. *Ber. Deut. Chem. Ges.* **36**: 3035. 1903.
83. TAPPEINER, H. VON. Über die sensibilisierende Wirkung fluoreszierender Stoffe auf Hefe und Hefepressaft. *Biochem. Zeitsch.* **8**: 47-60. 1908.
84. TAPPEINER, H. VON. Die photodynamische Erscheinung (Sensibilisierung durch fluoreszierende Stoff). *Ergeb. Physiol.* **8**: 698-741. 1909.
85. TAPPEINER, H. VON, and A. JODLBAUER. Über die Wirkung der photodynamischen (fluoreszierender) Stoffe auf Protozoen und Enzyme. *Deut. Arch. Klin. Med.* **80**: 426-487. 1904.
86. TAPPEINER, H. VON, and A. JODLBAUER. Die sensibilisierende Wirkung fluoreszierender Substanzen. 210 pp. Vogel; Leipzig, 1907.
87. TAUBER, H. Studies on crystalline urease. Inactivation by ultra-violet radiation, sunlight with the aid of a photodynamic agent, and inactivation by trypsin. *Jour. Biol. Chem.* **87**: 625-628. 1930.
88. TERROINE, E. F., and R. BONNET. Sensibilité comparée des formes actives et inactives des diastases aux rayons ultraviolets et à la chaleur. *Soc. Chim. Biol.* **9**: 982-1000. 1927.
89. THOMPSON, W. R., and R. HUSSEY. The effects of radiations from a mercury arc in quartz on enzymes. II. *Jour. Gen. Physiol.* **15**: 9-13. 1931.
90. THOMPSON, W. R., and R. TENNANT. A protective property of serum in irradiation of amylase with ultra-violet light. *Proc. Soc. Exp. Biol. and Med.* **29**: 510-511. 1932.

91. WAENTIG, P., and O. STECHE. Über die fermentative Hydroperoxydzersetzung. Hoppe Seyler's Zeitsch. Physiol. Chem. **76**: 177-213. 1912.
92. WARBURG, O., and E. NEGELEIN. Absolutes Absorptionsspektrum des Atmungsferments. Biochem. Zeitsch. **204**: 495-499. 1929. (*See also* Ibid. **193**: 339-346. 1928.)
93. WELS, P. Die Wirkung der Röntgenstrahlen auf die Katalase. Pflüger's Arch. Physiol. **201**: 459-487. 1923.
94. ZELLER, M., and A. JODLBAUER. Die Sensibilisierung der Katalase. Biochem. Zeitsch. **8**: 84-97. 1908.

Manuscript received by the editor July, 1935.

Editor's Note: Owing to circumstances beyond the control of the author this paper was necessarily shifted to its present position from its logical one with the group of papers (numbers 8, 9, and 10) on biological products.

INDUCED CHROMOSOMAL ABERRATIONS IN ANIMALS

THEODOSIUS DOBZHANSKY

California Institute of Technology, Pasadena

Introduction. Classification of chromosomal aberrations. Influence of X-rays on disjunction of chromosomes. Methods of detection and of studying chromosomal rearrangements. The mode of origin of chromosomal rearrangements. Permanence of the spindle fibers. Cytological maps. Cytological demonstration of crossing over. Gene changes associated with chromosome breakages. Mechanism of meiosis. References.

INTRODUCTION¹

The process of evolution is the resultant of several intimately interwoven, but virtually independent, processes. Since evolution implies the presence of hereditary differences between the ancestral and the derived forms, and since the only known method of the origin of hereditary differences is gene mutation, the process of mutation must be considered almost by definition the mainspring of evolutionary changes. It would be, however, fallacious to argue that the concepts of evolution and of gene mutation are synonymous. For we know at the present at least one more kind of change the significance of which seems to grow with the progress of exact studies on the mechanism of evolution. Comparative genetic as well as comparative cytological investigations on related forms of animal and plant life show that besides genic diversities, differences in the arrangement of chromosomal materials are encountered. No account of the causes of evolution can be either complete or satisfactory unless these latter differences are taken into consideration.

Rearrangements of the chromosomal materials offer, moreover, a profitable field for studies on the mechanism of heredity. The so-called chromosomal abnormalities are easily analyzable by a combination of genetic and cytological methods, and the differences between the "normal" and the "aberrant" structures can be described in sufficiently exact terms. The functioning of these altered structures can then be studied. Experience has demonstrated that the insight into the mechanism of heredity gained by this method is more profound than that gained by observations on the normal chromosomes only. This fact alone

¹ The manuscript of this article was first prepared and submitted to the editor in August, 1933. In the revision, November, 1934, mention of some of the new literature was made, but no adequate discussion given. It has been impracticable to specify this new material, but for the most part the dates of publication will adequately indicate the newer work receiving such brief attention.

makes investigations of chromosomal aberrations an important chapter of genetics, even disregarding their evolutionary significance. The various classes of chromosomal aberrations known at present were all observed before the discovery of their artificial production by X-rays. Chromosomal changes arise spontaneously in experimental cultures, and at least some of them are encountered among individuals collected in nature. But the frequency of their spontaneous origin seems to be generally so low that it was not before Muller made his discovery of their induction by X-rays that the field of chromosomal aberrations was really opened for study. Among animals, chromosomal aberrations, spontaneous as well as induced ones, have so far been investigated largely in a single organism, namely in the fly, *Drosophila melanogaster*. However, comparable phenomena have been discovered recently also in other forms, such as mice (Painter, 92; Snell, 125), grasshoppers (Nabours, 83; Robertson, 114; Nabours and Robertson, 84; Helwig, 52) and, possibly, in the parasitic wasp, *Habrobracon* (Greb, 48). A comparison of chromosomal aberrations known in *Drosophila* with those in a variety of plant species shows their profound analogy. The fundamental principles of the structure of the chromosomal apparatus are similar in all living forms, with the possible exception of bacteria and lower fungi. It is, therefore, not surprising that the changes of this apparatus should be accomplished by relatively few universally distributed methods.

CLASSIFICATION OF CHROMOSOMAL ABERRATIONS

The normal condition of the chromosomal apparatus in any strain, variety, or species may be defined as one in which (a) the number of chromosomes is constant, (b) every chromosome carries a definite set of genes, and (c) the genes within each chromosome are arranged in a constant linear series. Any deviation from the above regularities constitutes a chromosomal aberration. We may adopt a modification of the classification of chromosomal aberrations proposed by Bridges (17) and Morgan, Bridges, and Sturtevant (71).

ABERRATIONS INVOLVING SETS OF CHROMOSOMES

Polyploidy.—Normal individuals carry in most of their cells every chromosome in duplicate. Nondivision or fusion of nuclei in gametogenesis may result in the appearance in the following generations of individuals having every chromosome represented three times (triploid), four times (tetraploid), and so on. Just (54) induced polyploidy in *Nereis limbata* by ultra-violet radiation.

ABERRATIONS INVOLVING WHOLE CHROMOSOMES

1. *Polysonics* are individuals having one of the chromosomes of the normal set represented three or more times.

2. *Monosomies* are individuals having one of the chromosomes represented only once (or fewer times than the rest of the chromosomes if the individual is a polyploid). The origin of polysomies and monosomies is due to irregularities in the functioning of the mitotic mechanism. The daughter halves of the chromosomes in somatic divisions, and the homologues in meiotic divisions, may undergo *nondisjunction* (Bridges, 12) and pass to the same pole of the spindle instead of to the opposite poles. Monosomies may be produced also by *elimination* of chromosomes in any divisions.

3. *Compounding* is a union of separate chromosomes into a single body. Temporary compounding of several chromosomes into single "Samelechromosomen" is regularly observed in *Ascaris* and in certain insects. Whether compounding ever occurs as a permanent heritable aberration remains to be studied (see below).

4. *Fragmentation* is a separation of one chromosome into two or more independent ones.

ABERRATIONS INVOLVING SECTIONS OF CHROMOSOMES

This class of chromosomal aberrations may have the general name of rearrangements of chromosomal materials or simply chromosomal rearrangements.

1. *Translocation* (Bridges, 16) is a transfer of a section of a chromosome from its normal location to a new one. In *intrachromosomal translocations* the transfer is accomplished within a single chromosome. Such translocations seem to be rare, possibly because the technique used for finding translocations (see below) fails to detect them. Dubinin (38, 39) gives a preliminary account of a translocation in *Drosophila melanogaster* involving a transfer of a section of the left end of the X-chromosome to its right end. In *interchromosomal translocations* a section of one chromosome is transferred to a nonhomologous chromosome. Two main types of interchromosomal translocations may be distinguished:

a. *Simple translocation* (Dobzhansky, 28) is a transfer of a section of one chromosome (the donor) to another chromosome (the recipient). Simple translocation involves breakage of the donor chromosome only, the recipient chromosome remaining intact, or at least no section of the recipient being transferred on the donor.

b. *Reciprocal or mutual translocation* (Muller, 76; Dobzhansky, 28), known also as segmental interchange,² is an exchange of sections between

² The expression "segmental interchange" is used by several authors, especially by those working on plants. This term is objectionable because "segmental interchange" was originally used to designate cytological crossing over and is still frequently used in this sense. "Segmental interchange between nonhomologous chromosomes" is certainly too long a term to be convenient. Furthermore, Belling and Blakeslee (10) and Belling (9), who first used "segmental interchange" for reciprocal trans-

nonhomologous chromosomes. Both chromosomes involved in reciprocal translocations are simultaneously donors and recipients.

2. *Inversion* (Sturtevant, 131). A section of a chromosome may be rotated 180 deg. without removal from its place. Thus, if the order of genes in the original chromosome is *ABCDEFGF*, the chromosome carrying an inversion has the order *ABCFEDG*, or a similar one. Inversions are merely special cases of intrachromosomal translocations.

3. *Deficiency*. Bridges (13) defines deficiency as "the loss or inactivation of an entire, definite, and measurable section of genes and framework of a chromosome." The deficiencies first discovered in *Drosophila* (Bridges, 13; Mohr, 68) were too short to be visible cytologically, and for this reason Bridges mentioned the possibility of inactivation rather than a loss in his definition. Painter (92) observed in mice a cytologically visible deficiency, and proposed for similar cases the term "deletion" (used subsequently by Painter and Muller, 98, and other authors). It is obvious now that deficiencies of Bridges and of Mohr were losses and not inactivations. "Deficiency" and "deletion" are synonyms.

4. *Duplication* (Bridges, 14). An individual carrying a duplication has a normal chromosome complement plus an extra fragment homologous to a part of one of the chromosomes (the duplication). The fragment may be either free (in which case the cells contain an extra chromosome as compared with the normal condition), or it may be attached to another chromosome.

INFLUENCE OF X-RAYS ON DISJUNCTION OF CHROMOSOMES

Bridges found (12) that normal, untreated, females of *Drosophila melanogaster* occasionally produce eggs carrying two, and eggs carrying no *X*-chromosomes. The offspring coming from these exceptional eggs can easily be recognized, if a recessive female is mated to a male carrying sex-linked dominants. Regular offspring consist of dominant females and recessive males, and the exceptional offspring are recessive females (*XXY*, coming from *XX* eggs fertilized by *Y* spermatozoa) and dominant males (having one *X*- and no *Y*-chromosome, coming from no-*X* eggs fertilized by *X*-sperm). The production of the exceptional eggs is mostly due to nondisjunction of the *X*-chromosomes at the maturation divisions. The fact that the *XX* eggs are less frequent (1:2500) than the no-*X* ones (1:600) indicates, however, that some of the latter are produced by occasional loss of the *X*-chromosomes in female gametogenesis.

The frequency of the production of exceptional eggs in *Drosophila melanogaster* can be increased about 20 times if females are exposed to

locations, implied in this expression a definite hypothesis of the origin of translocations (by "illegitimate" crossing over between nonhomologous chromosomes). Although this hypothesis may be correct, it is by no means conclusively proved, and reflections of contentious hypotheses in terminology should be avoided.

X-rays (Mavor, 61, 62; Anderson, 3, 4, 5, 7). Exceptional females are less frequent in the offspring of treated flies than are the exceptional males, suggesting that both nondisjunction and elimination of chromosomes are increased by X-rays. Mavor (64) has studied the effects of exposing different parts of pupae to X-rays. In some cases the anterior half of the body was exposed to radiation, the posterior half being shielded by a silver plate. In other cases only the posterior half of the body (containing the gonads) was exposed. Mavor found that flies coming from pupae whose anterior half was irradiated produce no more exceptional eggs than control flies. On the other hand, irradiation of the posterior half produces as much effect as irradiation of the whole body. These data show that the action of X-rays on the disjunction of chromosomes is probably direct, rather than indirect, through an upset of the general physiological condition of the organism.

Demerec and Farrow (22, 23) found that X-ray treatment increases the frequency of primary nondisjunction also in *Drosophila virilis*. Most of the exceptional individuals produced in that species are males (no-X eggs), the exceptional females (XX eggs) being very rare. It appears therefore that in *Drosophila virilis* elimination of X-chromosomes rather than nondisjunction in the strict sense is produced by X-rays. The frequency of nondisjunction and elimination increases proportionally to the amount of treatment up to the dosage of 2000 r-units. Higher dosages produce a relatively small increase of the frequency of exceptional individuals.

Gynandromorphism in *Drosophila* was also induced by X-rays (Mavor, 63; Patterson, 100). Since the appearance of gynandromorphs is mostly due to elimination of one of the X-chromosomes in cleavage divisions this result seems to indicate that X-rays provoke elimination in both meiotic and mitotic divisions. This conclusion is justified in spite of the fact that the more recent studies of Patterson (101, 102, 103, 105, 106) have proved that a part of the gynandromorphs produced by radiation have not a whole X but only a part of it lost, and consequently gynandromorphism in this case is partly due to breakages of chromosomes and subsequent losses of some of the fragments, a phenomenon not so far observed in gynandromorphs appearing spontaneously.

Spontaneous nondisjunction of the fourth chromosomes in *Drosophila* was first studied by Bridges (15). Individuals monosomic for the fourth chromosome are easily distinguishable from normal flies in appearance, having a complex of the so-called "Haplo-IV" characters. Mohr (68) described mosaic individuals, the origin of which must have been due to nondisjunction or elimination of the fourth chromosomes in cleavage divisions. Muller (72, 75) and other authors found among mutations induced by X-rays many so-called "Minutes," some of which were undoubtedly "Haplo-IV." Dobzhansky (26) observed in the offspring

of treated flies rather numerous mosaic individuals which had a part of their bodies monosomic for the fourth chromosome. It is very probable that not only the X 's and the fourth chromosomes but also the large autosomes of *Drosophila* undergo nondisjunction and elimination due to X-ray treatment. The detection of these processes is, however, made difficult by the fact that monosomies and polysomies for these autosomes are inviable even in mosaics. Some of the "dominant lethals" induced by X-ray treatment (Muller, 72) are presumably just such monosomies and polysomies (Schultz, 115).

METHODS OF DETECTION AND OF STUDYING CHROMOSOMAL REARRANGEMENTS

The first translocations which were observed in *Drosophila* arose spontaneously (Bridges, 16; Bridges and Morgan, 19; Stern, 126, 127). The induction of translocations by X-rays was discovered by Muller (72, 73) and Muller and Altenburg (77, 78). Their results were soon corroborated by findings of Weinstein (138), Serebrovsky and his collaborators (120), and other authors.

The technique of finding induced translocations is based on the results of Bridges (16) who has shown that translocations produce linkages between genes located in different chromosomes, which, therefore, are normally independent. This technique was described by Muller and Altenburg (78) and by Dobzhansky (24, 26). Males having chromosomes "marked" by dominant genes are treated with X-rays and crossed to untreated females³ homozygous for the corresponding recessives (Fig. 1). In the F_1 generation males that show the characteristics of the marking genes are selected and back-crossed to unrelated recessive females. The offspring of such back-crosses consists normally of several classes representing all possible combinations of the marking genes (in the case shown in Fig. 1 four classes, AB , ab , Ab , and aB are expected), all classes being equal in frequency. Males carrying translocations produce, however, some gametes and zygotes having deficiencies and duplications for certain sections of the chromosomes involved in the translocation. As shown in Fig. 1, these deficiency and duplication zygotes are exactly those which carry the recombinations of the marking genes (Ab and aB). Since, at least in *Drosophila*, deficiencies and duplications either possess special somatic characteristics not present in normal flies, or are altogether inviable, the recombination classes Ab and aB are either visibly abnormal or completely absent.

In an experiment of the writer (Dobzhansky 24, 26) males carrying the dominants Bristle (B , second chromosome) and Dichaete (D , third

³ Males rather than females are used because they are able to withstand a stronger irradiation without becoming completely sterilized. It is usually advantageous to treat wild-type males and to cross them to females having their chromosomes marked by mutant genes. The experimental procedure is similar in both cases.

chromosome) were irradiated and crossed to females homozygous for the fourth chromosome recessive eyeless (*ey*). *Bl D* males were selected in F_1 , and back-crossed to homozygous *ey* females. The offspring of

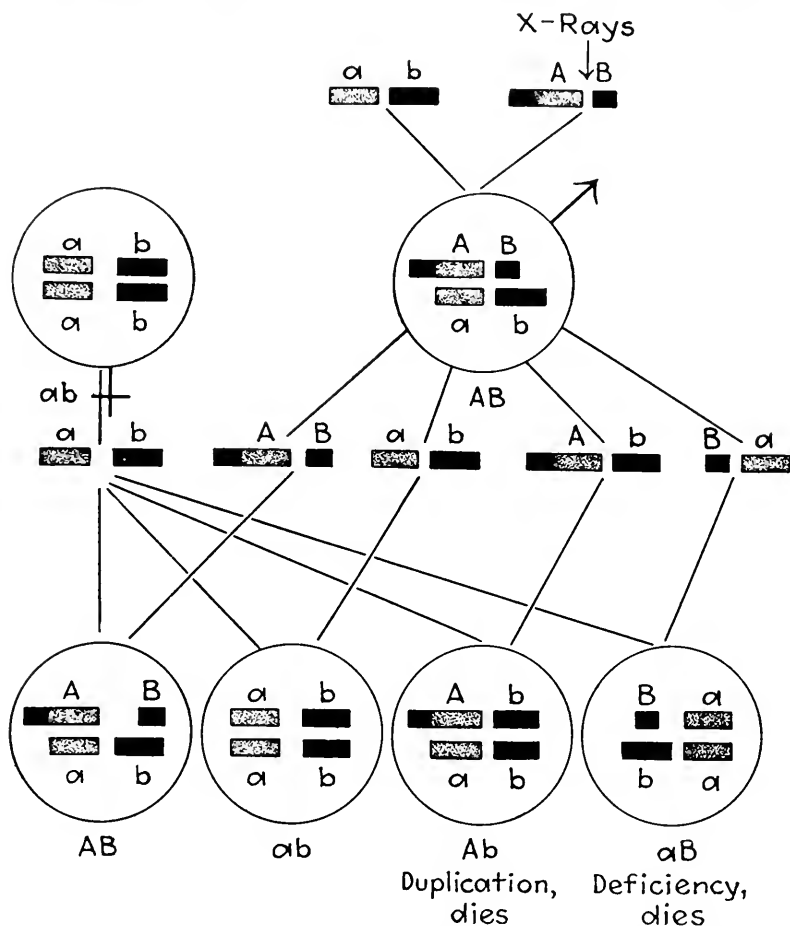

FIG. 1.—Scheme of the detection of a translocation. Genes *A* and *B* behave normally independently since they are located in different chromosomes (one of which is represented black and the other stippled). In individuals carrying a translocation involving these chromosomes the genes *A* and *B* exhibit linkage, since gametes *Ab* and *aB* produce no viable zygotes.

such a back-cross should consist of 16 equally frequent classes shown in Table 1. Among 121 males tested, 112 actually gave this result. But 9 males gave aberrant results.

The first four cultures shown in Table 1 show no recombinations for *Bl* and *D*; here translocations involving the second and the third chromosomes were induced. The remaining five cultures fail to show recombinations for *D* and *ey*. Here we are dealing with translocations between the third and the fourth chromosomes.

TABLE 1

Culture No.	Wild type		<i>Bl</i>		<i>D</i>		<i>ey</i>		<i>Bl D</i>		<i>D ey</i>		<i>Bl ey</i>		<i>Bl D ey</i>	
	♀	♂	♀	♂	♀	♂	♀	♂	♀	♂	♀	♂	♀	♂	♀	♂
1223	28	28	24	26	22	24	15	21
1239	22	16	20	20	28	21	14	19
1289	4	5	8	4	9	14	9	6
1401	3	8	7	7	2	4	4	12
1271	18	12	11	21	19	18	10	12		
1318	14	13	20	15	21	13	12	7		
1319	19	15	9	13	22	19	26	17		
1407	13	7	12	14	10	11	17	12		
1425	24	19	12	15	17	17	13	15		

As shown above, the apparent linkage observed between genes located in different chromosomes in translocations is due to the inviability of the recombination classes carrying duplications and deficiencies (Fig. 1). This apparent linkage provides a possibility of determining genetically

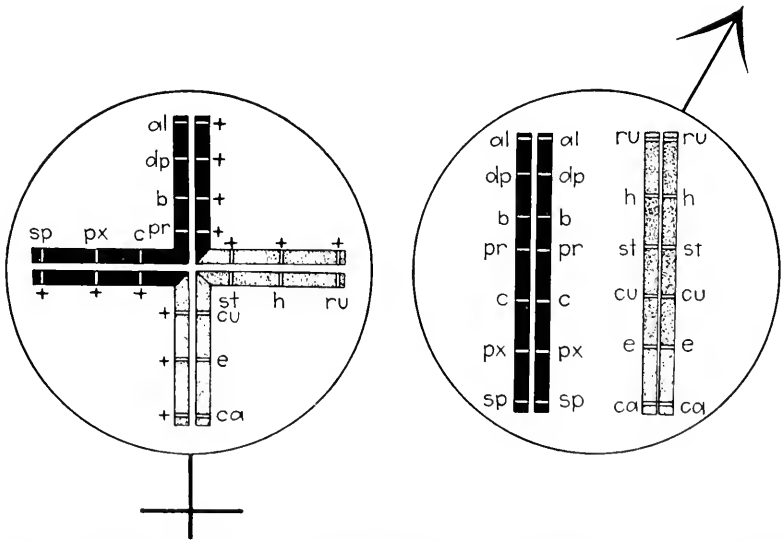

FIG. 2.—Determination of the points at which chromosomes are broken in translocations. A translocation carrying female heterozygous for a series of genes (left) is crossed to a male free from the translocation and homozygous for the respective genes (right).

the loci at which the chromosomes were broken and reattached in translocations, provided, of course, the spacing of genes in normal chromosomes is known, as is the case in *Drosophila*. Translocation females are made heterozygous for a series of genes located in both chromosomes involved, and are back-crossed to normal males homozygous for the same series of genes (Fig. 2). Crossing over takes place between the chromosomes

involved in the translocation and their normal homologues. Figure 2 represents a translocation in which both the second (black) and the third chromosomes (stippled) are broken at the middle, and halves of these chromosomes are exchanged. It is obvious that in such a case the strongest linkage would be observed between the genes *cu* and *c*, and between *st* and *pr*, indicating that breakages have taken place between these genes. By this method the loci at which chromosomes have been broken in translocations may be determined and entered on the genetic maps of these chromosomes. Cytological investigation of individuals carrying translocations gives independent evidence for the correctness of the interpretation reached on the basis of genetic studies.

As shown in the foregoing, deficiencies and duplications, provided they are viable, can be obtained in the offspring of translocations. Painter and Muller (98) proposed a convenient direct method for the detection of duplications for sections of the X-chromosome of *Drosophila melanogaster*. Wild-type males are treated with X-rays and crossed to females having attached X-chromosomes, and homozygous for a desired series of sex-linked recessives. X-ray treatment causes fragmentation of the X-chromosome in some of the spermatozoa of the treated males. Some of the fragments are lost. Such spermatozoa may fertilize eggs carrying the two attached X's (the attached-X females produce two kinds of eggs: those carrying two attached X-chromosomes, and those carrying a Y-chromosome, L. V. Morgan, 69). The result is the production of zygotes having two complete X's (coming from the mother), and a fragment, a duplication, of a third X (coming from the father). Such zygotes can be recognized by the suppression of some of the recessives located in the attached X's by the dominant allelomorphs located in the duplication.

In an experiment of the writer, wild-type treated males were crossed to attached-X females homozygous for the sex-linked recessives *y*, *w^a*, *ec*, and *f*. The following offspring were obtained:

<i>y w^a ec f</i> ♀	2185	Duplication	<i>w^a ec f</i> ♀	8
Wild-type ♂	1879	Duplication	<i>ec f</i> ♀	9
Superfemales	4	Duplication	<i>f</i> ♀	6
Wild-type ♀	3	Duplication	Wild-type ♀	1
<i>y w^a ec f</i> ♂	1	Duplication	<i>y w^a ec</i> ♀	1

The normal offspring are *y w^a ec f* females and wild-type males; wild-type females and *y w^a ec f* males are due to the occasional detachment of the X-chromosomes in the mother. The *w^a ec f* females carry duplicating fragments containing the locus of *y*; the *ec f* females—a duplication for *y* and *w^a*; the *f* females—a duplication for *y*, *w^a*, and *ec*; the *y w^a ec* females—a duplication for *f*. It is interesting to note that the male offspring of the original duplication females crossed to any male are invariably

sterile due to the absence of the *Y*-chromosome. This indicates that the fragmentation of the *X*-chromosome by *X*-rays is produced in spermatids or spermatozoa, but not in the spermatogonia or spermatocytes.

Patterson (100, 101, 102, 103, 106, 107) showed that, owing to the fact that chromosomes are already split in some of the spermatozoa at the time of treatment, mosaic individuals occur in the progeny of *X*-ray-treated flies. Such mosaics carry in a half of their bodies two normal *X*-chromosomes, and in the other half one complete *X*, and another *X*, a fragment of which is lost. If the normal *X* carries sex-linked recessive genes and the treated *X*-chromosome is wild-type, such mosaic individuals are readily recognizable. Patterson found that if a small section of the *X*-chromosome is lost, the mosaic fly is completely female, but if the deficiency is sufficiently long the mosaic becomes a gynandromorph, the part of the body carrying the deficiency being male.

Sturtevant (131, 133) proved that the majority of the so-called "factors suppressing crossing over" in the chromosomes in which they lie are actually inversions of sections of these chromosomes. Inversions with which Sturtevant has worked were either found in nature or arose spontaneously. Muller (72), Serebrovsky and his coworkers (120), Serebrovsky (118), Oliver (90) and others found that inversions arise frequently as a result of *X*-ray treatment. Inversions are detected through a reduction of crossing over produced by them in the chromosomes affected. The laboriousness of this method is, no doubt, responsible for the fact that up to now we possess no systematic data on the frequency of the induced inversions.

THE MODE OF ORIGIN OF CHROMOSOMAL REARRANGEMENTS

A number of investigators have obtained data relating to the problem of the mechanism of the origin of the spontaneous and the induced chromosome rearrangements. An extensive study on the relation between the intensity of the *X*-ray treatment and the frequency of induced chromosome rearrangements, and that of the induced mutations was made in *Drosophila melanogaster* by Oliver (87, 89, 90). Oliver applied five different dosages of *X*-rays (t_1 to t_{16}), which can be arranged in a series in which every following member is twice as great as the preceding one. The minimum dosage (t_1) was equal to about 385 r-units. The results of one of Oliver's experiments, in which only sex-linked lethals and only those chromosomal rearrangements which are associated with lethals were detected, are summarized in Table 2.

The results of this and of other experiments show that the frequency of both induced mutations and chromosome rearrangements is directly proportional to the amount of treatment. The possibility that higher dosages produce a somewhat disproportionately great effect on chromosomal rearrangements does not seem, however, excluded.

TABLE 2.—THE AMOUNT OF TREATMENT, THE FREQUENCY OF INDUCED MUTATIONS, AND THE FREQUENCY OF CHROMOSOMAL REARRANGEMENTS
After Oliver

Dosage	Percentage of lethal mutations	Percentage of chromosomal rearrangements
t_{16}	16.09	5.52
t_8	9.87	2.43
t_4	4.90	0.35
t_2	3.23	0.40
t_1	1.42	0.075
Control	0.24	

The relation of the frequency of translocations involving specific chromosomes to the length of these chromosomes was studied by Muller and Altenburg (78), Shapiro (122), and by Patterson, Stone, Bedichek, and Suche (109). Translocations between the second and the third chromosomes, which are the longest in *Drosophila melanogaster*, are by far the most frequent. On the other hand, the comparatively short X-chromosome and, especially, the minute fourth are involved much less frequently. No exact quantitative relation can be established between these variables, but it is still clear that the longer a chromosome the more likely it is to break due to the effects of X-rays. Whether a chromosome is equally likely to break at any level or there exist "weak spots" where breakages are most frequent is an open question. There are some indications that certain regions (the vicinity of the spindle fibers) break especially frequently. This has been recently proved by Patterson, Stone, Bedichek, and Suche (109). Their very extensive data show that a majority of breaks occurs in the vicinity of free and spindle-fiber ends of the chromosomes. Shapiro (122) found that the frequency of translocations is highest in the portion of the sperm produced by males immediately after an X-ray treatment and decreases in further portions. The chromosomes in the mature spermatozoa seem, therefore, more liable to break than those in the spermatocytes or spermatogonia.

The precise mechanism whereby chromosomes are broken and reattached is a matter of conjecture at the present. Belling (9) supposed that translocations arise owing to the "segmental interchange" or "illegitimate crossing over between nonhomologous chromosomes." Muller (72), Painter and Muller (98), and Dobzhansky (26) suggested that chromosomes may stick together in certain places owing to the effects of X-rays, and may be subsequently broken by the action of the spindle fibers. Serebrovsky (117) and Dubinin (40) elaborated this suggestion to explain the origin not only of translocations but of inversions and even point mutations as well. The difference between this

scheme and that of Belling consists merely in that according to Belling only reciprocal translocations and inversions, but no simple translocations, can be produced. A third possibility is that chromosomes are fragmented by X-rays, and the fragments possessing no spindle fiber are either lost or somehow attached to other chromosomes. Fragmentation of chromosomes due to X-rays was, indeed, observed even before the discovery of inheritable chromosome rearrangements (Hertwig, 53; Mohr, 67; Alberti and Politzer, 1). Direct cytological observations on chromosomes in treated cells would seem the logical way toward a solution of these problems.

Lewitsky and Araratian (59) studied the effects of irradiation on chromosomes in root tips of *Crepis* and other plants, employing various intervals of time after treatment. They observed secondary, tertiary, and even quaternary reconstructions of the chromosome apparatus. This suggests that an X-ray treatment may have an aftereffect on the production of chromosome rearrangements. Since no aftereffect is produced on gene mutations (Timoféeff-Ressovsky, 135), further observations are much needed. Lewitsky and Araratian describe no pictures suggesting a rupture of chromosomes due to their sticking together, but neither have they seen a union between fragments once separated.

The problem of the existence of simple translocations is likewise not settled. In plants, especially in maize and *Oenothera*, all known translocations are reciprocal, though the exchanged sections may be extremely unequal in length. Many reciprocal translocations are known in *Drosophila* (Sturtevant and Dobzhansky, 134; Dobzhansky and Sturtevant, 36; Bolen, 11; Oliver and Van Atta, 91; and others), but other translocations seem to be simple (Muller and Painter, 80; Muller, 76; Dobzhansky, 25, 29, 32; and others). Both reciprocal and simple translocations occur in *Orthoptera* (Nabours and Robertson, 84; Helwig, 52). It should, however, be kept in mind that what appears to be a simple translocation may actually be a reciprocal one, involving an exchange of extremely unequal sections. The fact that the very small fourth chromosome may participate in reciprocal translocations (Bolen, 11) is very suggestive in this respect. The introduction of the method of studying chromosomes in the salivary glands of *Drosophila* (see below) may be expected to bring a final solution of this problem.

Although the possibility that all translocations are reciprocal is not excluded, it has, certainly, not been proved conclusively. Some data argue rather against it. Dobzhansky (32) studied nine translocations involving transfers of sections of the second chromosome to the Y-chromosome of *Drosophila*. If these translocations were reciprocal, a section of the Y should be found in every case attached to the remnant of the second chromosome. Since the Y-chromosome is a long one, these sections might be expected to be cytologically visible in at least some

cases. This is not so. Hence, either these translocations are simple, or the Y is especially likely to break very close to one of its ends. Since the discovery by Patterson, Stone, Bedichek, and Suche (109) that chromosomes are likely to break near the free ends, this argument loses some of its force.

The possibility of the so-called "lateral attachment" of chromosome fragments suggests also that simple translocations do occur. By lateral attachment is meant an attachment of a fragment not to an end of a broken or an unbroken chromosome, but to its side. Lateral attachments lead to formation of branched (Y-shaped) chromosomes. The existence of a lateral attachment is conclusively proved genetically in one

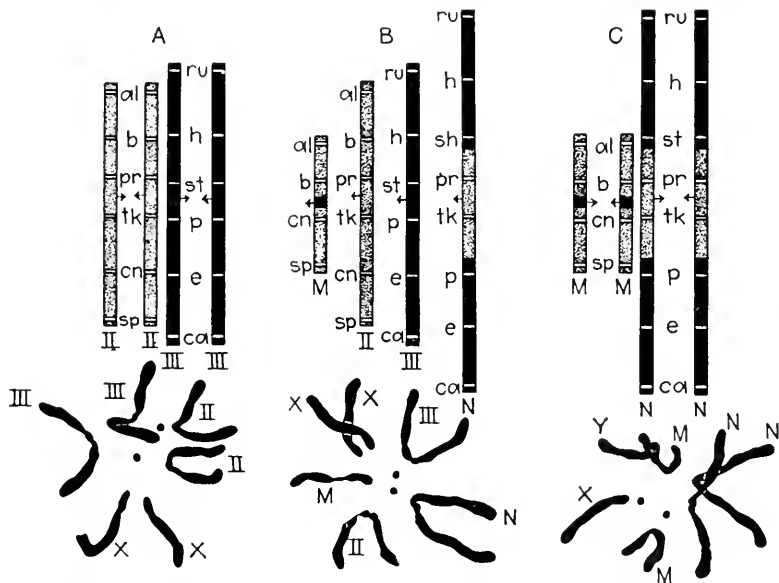

FIG. 3.—A, the second chromosome (stippled) and the third chromosome (black) of a normal *Drosophila melanogaster*; B, the second and third chromosomes of an individual carrying a translocation in heterozygous condition; C, same of an individual homozygous for the same translocation. Below—chromosome plates of each of these three kinds of individuals.

of the translocations in *Drosophila* (Sturtevant's *E*-translocation—Dobzhansky and Sturtevant, 36), and has been observed cytologically in *Allium* (Levan, 57). Translocations involving lateral attachments can be reciprocal only if a very short section of the recipient chromosome is excised interstitially, and both the free end of the recipient chromosome and a fragment of the donor chromosome are attached to the broken end thus made available. An excision of a chromosome section and an intercalation of a section of another chromosome in its place have, to be sure, been observed in *Drosophila* (Oliver, 88, and an undescribed translocation studied by Sturtevant, which has the chromosome structure shown in Fig. 3).

The discovery of crossing over in *Drosophila* males induced by X-rays (Patterson and Suche, 110; Friesen, 42) may conceivably have a bearing on the problem of the origin of induced translocations. Since, however, in this case breakages and reattachments take place in chromosomes homologous to each other, and apparently always at the same level, a comparison of the crossing over in the male with translocation is very hazardous.

PERMANENCE OF SPINDLE FIBERS

The location of the attachments of the spindle fibers in the chromosomes of *Drosophila melanogaster* was determined before the discovery of the cytologically visible translocations and other chromosomal rearrangements. At anaphases and telophases the spindle attachments lie closest to the poles of the spindle, and the free ends of the chromosomes are directed away from the poles. Recently Kaufmann (56) has made a more exact cytological determination of the location of the spindle attachments by observing the achromatic breaks in the prophase chromosomes. In the large V-shaped autosomes (the second and the third chromosomes) the spindle attachments lie at the apices of the V's, in the J-shaped Y-chromosome at the junction of the two limbs, and in the X- and the fourth chromosomes the attachments are subterminal.

The localization of the spindle attachments was determined genetically by Bridges and Morgan (19) on the basis of distribution of double cross-overs, by L. V. Morgan (70), Anderson (4), and Redfield (111, 112) from data on equational exceptions, by Stern (126, 127) from studies on the interactions of bobbed allelomorphs located in the X- and Y-chromosomes, by Sturtevant (131, 133) and Dobzhansky (24, 26, 28, 29) from disturbances of crossing over produced by inversions and translocations, and by Bolen (11) by observing duplications for sections of the fourth chromosome. The location of the spindle attachments in terms of the genetic maps of chromosomes is shown in Figs. 3, 5, and 6. The results of the cytological studies on translocations completely corroborated the earlier determinations of the location of the spindle attachments based on purely genetic data. In every case in which breakages of chromosomes were found genetically to lie close to the genetic loci of the spindle attachments, cytological studies showed the chromosomes to be broken near the attachment constrictions (Muller and Painter 80, 81; Dobzhansky 24, 26, 27, 29, 31, 32).

The discovery of translocations and other chromosome rearrangements which produced visible alterations of chromosomes furnished a method for an experimental attack on the problem of permanence of spindle attachments. Some inverted sections were found to involve genes lying on both sides of the attachment constrictions. In such inversions in the second chromosomes of *Drosophila* the loci of the spindle

attachments are sometimes transferred from the middle to one of the ends of the genetic chromosome. Individuals carrying these inversions were found cytologically to possess very long rod-shaped, or J-shaped, second chromosomes instead of the normal V-shaped ones (Van Atta, 136, 137; Schultz and Dobzhansky, 116). Since the shape of a chromosome at the equatorial plate stage is determined by the location of the attachment constriction (the latter being directed toward the center of the plate, and the free end of the chromosome toward the periphery), these results suggest that the spindle attachment is a permanent feature of the organization of chromosomes.

Still more conclusive evidence in favor of the permanence of the spindle attachments is afforded by comparative studies on various translocations. Chromosomes are fragmented by X-rays; some of the fragments may remain free and others may reattach to different chromosomes. The question is, then, whether a fragment not including the spindle attachment of the old chromosome can remain free and develop a spindle attachment *de novo*, or whether two fragments both possessing a spindle attachment can unite and form a new chromosome with two attachments. This question may be answered in the negative, since no such cases have been encountered, in spite of the large number of translocations analyzed in detail. The fragments remaining free are invariably those which include the spindle attachment of the old chromosomes, and the fragments that become attached to other chromosomes are fiberless. The only possible conclusion is, therefore, that fiberless fragments and compounds having more than one spindle attachment are eliminated because of their inability to behave normally at mitosis.

This conclusion seems to be contradictory to a series of facts dealing with compounding and fragmentation of chromosomes. Can two or more separate chromosomes unite permanently into one, and can a chromosome be broken into several separate chromosomes? It was assumed for a long time that such changes take place. Even disregarding the temporary unions and fragmentations of chromosomes observed in *Ascaris* and in the gametogenesis of certain insects (which may be an entirely different phenomenon), changes in chromosome numbers, and consequently also in the number of spindle attachments, undoubtedly take place in phylogeny. Even within the genus *Drosophila* the chromosome number varies from three to six pairs (there being no evidence of reduplications and losses of whole chromosomes), and similar differences are observed between races of *Phragmatobia* (Seiler), in certain *Orthoptera* (McClung), and in other species of animals and plants.

It should be pointed out that the evaluation of evidence derived from comparison of races and species of unknown origin is always a matter of contention. An exact study of the situation can be carried through only in cases when a comparative genetical-cytological analysis of the

alleged compounding and fragmentation is practicable. A deficiency for the spindle-fiber-attachment region of a chromosome may produce a fiberless fragment which is cytologically indistinguishable from the normal chromosome. Such a fragment may become attached to another chromosome, thus simulating a permanent compounding of two whole chromosomes. Formation of duplicating fragments including the spindle attachment may increase the chromosome number (Painter and Muller, 98; Dobzhansky, 31, 33). If, then, a translocation from one of the chromosomes to the duplicating fragment takes place, the resulting chromosome complement may suggest a fragmentation of a chromosome with a *de novo* formation of a spindle attachment.

The only instance of an apparently real permanent compounding and fragmentation of chromosomes is the case of the attached *X*-chromosomes in *Drosophila melanogaster*. L. V. Morgan (69) and Sturtevant (133) studied such spontaneous attachments of the two rod-shaped *X*'s to form a single V-shaped compound, and Anderson (4) apparently induced it by *X*-rays. On the other hand, L. V. Morgan found that the attached *X*'s sometimes fall apart spontaneously, and Muller and Dippel (79) increased the frequency of this detachment by *X*-rays. The details of this phenomenon seem to be, however, obscure at the present, since it is not known whether the free *X*-chromosomes that emerge from the attached-*X* compound are absolutely identical with the normal *X*-chromosomes. The discovery of Kaufmann (56) that the spindle-fiber attachment in the *X*-chromosome of *Drosophila melanogaster* is subterminal, and not terminal, as was supposed previously, makes a further analysis of the attached-*X* case especially imperative. (Such an analysis has been carried through by Kaufmann (55). The detachments of the attached *X*'s are due to crossing over between the *X*- and *Y*-chromosomes. Thus, the attached-*X* case can no longer be cited as an instance of compounding and fragmentation of chromosomes.)

CYTOLOGICAL MAPS

Chromosomal rearrangements are detected in *Drosophila*, as a rule, by genetic methods. Linkages between genes not usually manifesting linkage indicate the presence of translocations; suppression of crossing over is in many cases evidence of the presence of inversions; suppression or manifestation of genes sometimes shows that duplications and deficiencies have arisen. Not only can the presence of chromosomal rearrangements be detected but the details of their structure can also be studied genetically. As has been shown, the loci at which chromosomes are broken and reattached in translocations are determined by the same methods which are used for studying the loci of new mutant genes. Changes leading to gene mutations are, however, different from chromosomal rearrangements in that the former produce no visible alterations

of chromosomes while the latter should at least in certain cases do so. The question arises whether the genetic methods used for the study of chromosomal rearrangements are dependable in the sense that the conclusions arrived at by these methods can be justified by cytological observations.

Stern (126, 127, cf. Muller, 74) was first to discover cytologically alterations of the chromosome structure produced by translocations between the X- and the Y-chromosomes of *Drosophila*. He concluded on the basis of genetic data that in a certain stock a fragment of the Y-chromosome was attached to the spindle-fiber end of the X-chromosome, near the locus of the gene bobbed. An investigation of the chromosomes has shown this conclusion to be valid. Muller and Painter (80), Painter and Muller (98), Dobzhansky (24, 27), and many other authors on *Drosophila*, and Nabours and Robertson (84) on *Apotettix* gave further examples of the same kind. In a series of translocations, genetic data suggested that fragments of certain chromosomes were attached to other known chromosomes. As expected, it was found cytologically that some chromosomes were shorter than normal, and that other chromosomes were increased in length by about the same amount of material which was subtracted from the former.

These results are interesting not only because they give an additional proof of the soundness of the fundamental assumptions of modern genetics, but especially because they furnish a method whereby certain problems can first be attacked experimentally. Among such problems is that of the distribution of cross-overs in the chromosomes, and that of the nature and significance of the genetic maps.

Genetic maps, first obtained for *Drosophila melanogaster* by the Morgan school, are known at present for the chromosomes of a series of species of animals and plants. Genetic maps show the linear order in which the genes are arranged within the chromosomes, and also the distances from one gene to the other, expressed in terms of the frequencies of crossing over between them. The information used in construction of genetic maps consists of the data on the degree of linkage exhibited by genes in various combinations. Consequently, genetic maps are merely a most condensed summary of the available statistical data on the behavior of genes in different crosses.

The relative distances between the genes on the genetic maps may correspond to the actual spatial relationships in the chromosomes only provided the frequency of crossing over per unit distance is constant in all parts of the chromosomes. This proviso has never been proved; hence it has always been realized that the genetic maps may give a distorted conception of the relative lengths of the different parts of the chromosomes (Bridges and Morgan, 19; Morgan, Bridges, and Sturtevant, 71; Muller, 72). Obviously, if crossing over per unit length takes place

in some regions of chromosomes more frequently than in others, the former will be represented relatively too long and the latter too short by the genetic maps.

The discovery of translocations and of other rearrangements producing alterations of chromosomes which are visible under the microscope opens the possibility of constructing so-called cytological maps of chromosomes. The points at which the chromosomes are broken and reattached in various chromosome rearrangements can be determined genetically by the same methods which are used for the localization of genes. The loci of breakages and reattachments may, then, be entered on the genetic maps, their position in respect to, and their distance from the loci of various genes being, thus, known (Figs. 3 to 6). However, since, the location of breakages and reattachments may also be seen cytologically, their position can be determined with respect to the ends of the chromosomes, the spindle attachments, and the secondary constrictions discovered in the *Drosophila* chromosomes by Bridges (18), and studied further by Dobzhansky (26, 27, 29, 30, 31, 32) and, especially, by Kaufmann (56; cf. also Muller and Painter, 81). If the breakages lie genetically close to the loci of known genes, one may reasonably assume that the latter lie in the chromosomes in more or less close proximity to the observed breakage points. The correlation between the genetic and the cytological maps of a given chromosome is hereby established. A cytological map may be defined as one which shows the location of various genetically determinable points in the microscopically visible chromosomes.

The localization of the four linkage groups of genes in the four pairs of chromosomes of *Drosophila melanogaster* was established by Bridges (12, 15) who showed that the rod-shaped X-chromosomes are carriers of the sex-linked genes, and that the small fourth chromosomes carry the fourth linkage group. The two large V-shaped autosomes must therefore, carry, the second and the third linkage groups, respectively. These autosomes are noticeably unequal in length and also differ from each other in the prominence of certain constrictions. Dobzhansky (24, 27) found that in translocations involving the third linkage group the longer pair of V-shaped chromosomes is visibly changed (Fig. 6), and in those involving the second linkage group the shorter pair is altered. Hence, the longer of these is the third chromosome, and the shorter is the second chromosome (Figs. 3 and 6).

The cytological map of the X-chromosome of *Drosophila melanogaster* was studied by Painter and Muller (98), Painter (93, 94), Muller and Painter (81), Dobzhansky (31, 33) and Sivertzev-Dobzhansky and Dobzhansky (124). Probably the most interesting fact revealed by these studies is that the proximal one-third of the length of the chromosome contains but a single known gene, namely, bobbed (the stippled

part of the chromosome in Fig. 4). This part of the chromosome is called the inert region. Little crossing over takes place within this region (for its genetic length is extremely small), no mutations except at the locus of bobbed have been observed, and individuals in which this region is deficient survive at least as heterozygotes, while deficiencies for sections of similar lengths in other chromosomes are invariably lethal. Nevertheless, the part of the chromosomes occupied by the inert region appears quite normal cytologically, and translocations and inversions are known to involve break-

ages of the chromosome in this region. Since bobbed is the only known sex-linked gene having an allelomorph in the Y-chromosome, and since the Y-chromosome is also composed of genetically inert material, the inert region of the X is probably homologous to a section of the Y-chromosome. The function of the inert region in the germ plasma is not definitely known. It is this region of the X-which pairs with the Y-chromosome at meiosis, and this fact makes it tempting to suppose that its function is to insure normal pairing and disjunction of the X-Y pair of chromosomes in male gametogenesis. No inert regions are

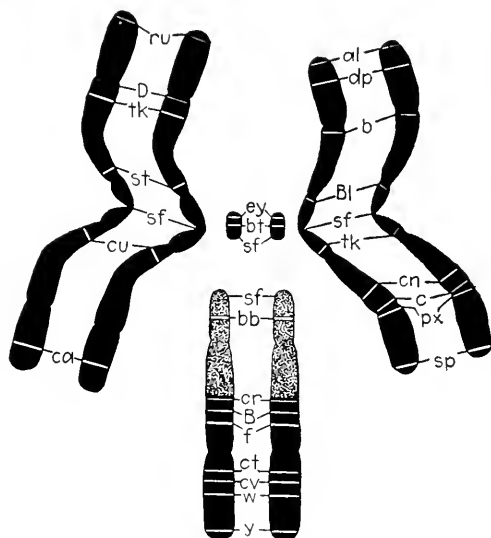

FIG. 4.—Cytological maps of the chromosomes of *Drosophila melanogaster*, showing the approximate location of various genes and of the spindle fibers (*sf*). The inert region of the X-chromosome represented by the stippled portion of the rod-shaped chromosomes. The longer V-shaped chromosomes (left) are the third chromosomes; the shorter V-shaped chromosomes (right) are the second chromosomes; the smallest pair, the fourth chromosomes.

so far known in the autosomes of *Drosophila*, but the data now available are insufficient to exclude the possibility that short genetically inert regions may be present there. (This, indeed, has been proved to be the case by Heitz (49, 50), who discovered that the middle sections of the second and third chromosomes, adjacent to the spindle attachments, behave in prophases differently from the remaining parts of these chromosomes, and similarly to the inert region of the X-chromosome. These sections are, then, probably inert in the same sense as the proximal third of the X-chromosome is inert. Whether or not the loci of some of the known genes are located in these inert regions (as suggested by our cytological maps, Fig. 4) remains to be seen. If this were true, the "inertness" of these regions would not be disproved,

just as the presence of the gene bobbed in the inert region of the *X*-chromosome does not constitute a contradiction of terms.)

The distal two-thirds of the *X*-chromosome may be called the active region, since all the numerous sex-linked genes of *Drosophila* except bobbed are located there. A comparison of the genetic and cytological maps of this region (Figs. 4 and 5) shows that the linear order of genes on the genetic map is similar to that in the actual chromosome. A striking discrepancy is observed if the relative distances between genes on the genetic and the cytological maps are compared. The genetic distance between the loci of *y* and *w* equals 1.5 map units, the whole chromosome being about 70 map units long (Fig. 5). Cytologically, the *y-w* distance is equal to about one-fifth of the active region. The

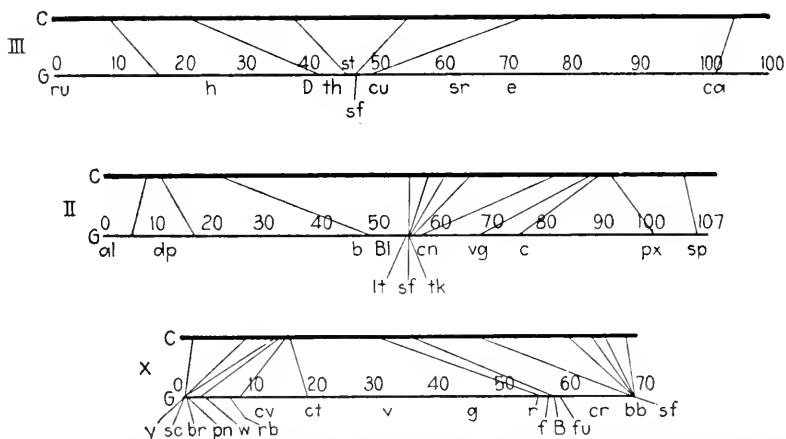

FIG. 5.—Comparison of the genetic and cytological maps of the third (III), second (II), and *X*-chromosomes (*X*) of *Drosophila melanogaster*. *C*, the cytological map; *G*, the genetic map. Figures indicate the genetic distances in map units.

discrepancy is obvious. On the other hand, the *w-g* interval (Fig. 5) which constitutes considerably more than a half of the length of the genetic map is less than one-fourth of the cytological chromosome.

The cytological maps of the second and third chromosomes were studied by Muller and Painter (80) and by Dobzhansky (24, 25, 26, 27, 29, 32). In both chromosomes the linear seriation of genes was found to be identical in the genetic and the cytological maps (Figs. 4 to 6). This corroborates the hypothesis of the linear arrangement of genes within the chromosomes which was advanced by Morgan and by Sturtevant, and which for years has been one of the main working hypotheses in genetics. But again, similar to the condition found in the *X*-chromosome, the relative distances between genes on the genetic and the cytological maps of the second and third chromosomes appear to be widely different. In both chromosomes the genes lying near the spindle attachments are relatively much farther apart on the cytological than on the

genetic map. Thus, the distance between the third chromosome genes *st* and *cu* (Figs. 4 to 6) is equal to six map units or about one-eighteenth of the total length of the genetic map. The *st-cu* interval, however, is no less than one-fifth of the chromosome cytologically. The genetic distances between the second chromosome loci *lt*, *rl*, and *tk* are very small, being equal to fractions of one map unit, or less than one-hundredth of the genetic map. Cytologically this region amounts to about one-fourth of the chromosome. The *b-lt* interval is shorter than one-fifteenth of the length of the genetic chromosome, but longer than one-fourth of its cytological map.

The distances between the genes located near the middle of either limb of the second and the third chromosomes are relatively much longer genetically than cytologically. For instance, the *cn-px* and the *dp-b* intervals in the second chromosome constitute each about one-third of the whole genetic map, but cytologically the length of these intervals is almost negligibly small (Figs. 4 and 5). Finally, the distances between the genes lying close to the right end of the second chromosome, and probably also close to its left end, are again somewhat longer cytologically than expected on the basis of the genetic map (the *px-sp* and *bw-sp* intervals, Fig. 5). Whether the same relation holds true for the third chromosome is as yet not clear, because the number of known breaks in the end regions of this chromosome is too small.

The cytological location of genes in the small fourth chromosome was studied by Bolen (11). In a translocation this chromosome was broken, the fiberless fragment became attached to the X-chromosome, and a fragment of the X became attached to the remaining part of the fourth which preserved its spindle fiber. Duplications for either part of the fourth chromosome are viable, and this enabled Bolen to show that the gene *bent* is located closer to the spindle fiber than the gene *eyeless* (Fig. 4).

As suggested above, the discrepancies between the genetic and the cytological determinations of the relative distances between genes are due to the variable frequency of crossing over per unit length in the different parts of the chromosomes. In spite of the fact that the present knowledge of the cytological maps leaves much to be desired, a comparison of the genetic and cytological maps of the respective chromosomes even now suggests certain interesting generalizations. In the vicinity of the spindle fiber attachments the frequency of crossing over per unit of the absolute distance is low, and consequently the genetic distances are much less than the cytological ones (the inert region of the X, the *b-cn* interval in the second, and the *D-cu* interval in the third chromosome). In the regions more remote from the spindle attachments, but not too close to the ends of the chromosomes, the frequency of crossing over is high, hence the genetic distances are relatively greater than the cytologi-

cal ones (*w-r* interval in the X, *dp-b* and *cn-pr* intervals in the second, *ru-D* interval in the third chromosome). Finally, crossing over near the free ends of the chromosomes is again infrequent, resulting in the genetic distances being relatively too small (the *y-w* interval in the X, *px-sp*, and, probably, *al-dp* intervals in the second chromosome; in the third chromosome the situation in this respect is not clear). The significance of these regularities in the distribution of cross-overs along the chromosomes is as yet a matter of speculation, but the importance of these facts for any theory of crossing over is obvious.

A knowledge of the cytological maps throws light on the phenomenon of crowding of genes in certain regions of genetic maps. The genetic maps of *Drosophila melanogaster* (and also of other species) show "clusters" of known mutant genes located very close to each other, and relatively long empty spaces in which genes seem to be scarce. At first glance this phenomenon might suggest that genes in certain regions of the chromosomes are rather more likely to mutate, while other regions are more stable. The crowding of genes proves to be, however, an illusion due to variable frequencies of crossing over. The regions of the genetic maps showing clusters of genes are exactly those which are relatively much longer cytologically than they are represented by the genetic maps. Conversely, the spaces with apparently few genes correspond to relatively very short sections of chromosomes. If the maps are drawn on the cytological scale, the distribution of genes becomes more or less uniform. Whether this distribution is completely random cannot be decided at present, because of the incompleteness of the cytological maps. The inert region in the X, which, in spite of its considerable length, contains only a single known gene is certainly an exception to this rule. It should also be remembered that the cytological maps now available in *Drosophila* are constructed exclusively on the basis of studies of metaphase chromosomes. It is entirely possible that if the chromosomes at other stages of the life cycle (especially at prophase) were studied we might obtain cytological maps which would be somewhat different from those known at present.

Our knowledge of the cytological maps in *Drosophila* has entered into a new period of development owing to the introduction by Painter (95, 96, 97) of the method of studying chromosomes in the salivary gland cells. As shown by a number of investigators, notably by Heitz and Bauer (51), the chromosomes in the cells of the salivary glands in Diptera grow to enormous dimensions (compared with the chromosomes in oögonia or nerve cells), and become long and relatively narrow cylinders, consisting of alternating light and dark disks or cross bands of various thicknesses, and showing a number of constrictions and inflated places. The bandings and other characteristics are constant in their relative

positions, so that not only the different chromosomes but even their rather minute sections can be recognized and identified.

In *Drosophila*, all the chromosomes of a nucleus become attached together at the spindle fibers to the so-called chromocenter—a foamy mass showing no clear cross striations, and formed by an involution of the inert regions of all the chromosomes (Heitz, 49, 50; Painter, 95, 96). Moreover, in the salivary glands of the grown-up larvae and young pupae the homologous chromosomes undergo a process of very intimate pairing which, at least superficially, resembles the meiotic pairing. The pairing is remarkably accurate so that the homologous bands are closely apposed to each other. This pairing is especially advantageous for studying chromosome rearrangements, since it enables one to determine the location of breaks and reattachments with a hitherto undreamed degree of accuracy (Painter, 96, 97).

The relative distances between various genes on the cytological maps built on the basis of the salivary gland chromosomes are sometimes different from those on the ordinary cytological maps (Painter, 97). This is due primarily to the practical disappearance of the inert regions of the chromosomes which are included in the chromocenter in the salivary-gland cells, but also to some other differences thus far not understood.

The possibilities open by the salivary-gland-chromosome method cannot be overestimated, as shown already by the results of Painter and others. Very small deficiencies, duplications, and inversions can be detected, and their extent can be studied. It is tempting to suppose that each of the disks composing the salivary-gland chromosomes has a definite relationship to a single gene. Even if this supposition proves to be far too crude, the problem of the possible effect of the apparent and real point mutations on the cytologically visible chromosomes can at last be approached. Finally, a comparison of the salivary-gland chromosomes in closely related species may give some much needed information on the nature of specific differences.

CYTOLOGICAL DEMONSTRATION OF CROSSING OVER

Studies on cytological maps have afforded conclusive proof of the theory of the linear arrangement of genes within the chromosomes. As is well known, this theory has been arrived at by Morgan on the basis of studies on crossing over in *Drosophila*. Morgan assumed that genes are arranged in a definite linear order, and that this order is preserved during the entire life cycle of the cell. At gametogenesis, however, the homologous chromosomes exchange segments, and this process of segmental interchange has its genetic expression in the variable degrees of linkage exhibited by various genes. Although the whole development of genetics since the time when Morgan advanced this theory has justified

completely his assumptions, and although the foregoing observations on the cytological maps have proved the main corollary of Morgan's theory, segmental interchange as the cytological basis of crossing over had still to be inferred from the genetic data. The experiments of Stern (128) on *Drosophila* and of Creighton and McClintock (21) on maize have filled this gap.

Stern (128) used in his study two translocations in *Drosophila melanogaster*, one involving the X- and the Y-chromosomes, and the other involving the X- and the fourth chromosomes. In the former, a section of the Y is attached to the spindle attachment end of the X, the X-chromosome appearing cytologically as J-shaped instead of rod-shaped as is normally the case. In the latter the X was broken between the genes forked and bar (cf. Fig. 4), the left fragment (*y-f*) was attached to the fourth chromosome, and the right one (*B-bb*) is free. Individuals carrying this translocation have instead of the normal X-chromosome two rod-shaped fragments of a length equal to about one-half of the normal X, and have only one instead of two free fourth chromosomes (since the other fourth, to which a fragment of the X is now attached, appears rod-shaped).

Stern marked the chromosomes involved in these translocations by appropriate genes and obtained females which were heterozygous for both translocations simultaneously. Such individuals have instead of the two normal X's one J-shaped chromosome (the X with the fragment of the Y attached to it), two short rod-shaped chromosomes (the broken X of the X-IV translocation), and one free fourth chromosome. These females were crossed to cytologically normal males. In the offspring some individuals were cross-overs between *f* and *bb* (cf. Fig. 4). It is easy to see that there must be two types of such cross-overs, which are easily distinguishable genetically, by observing the marking genes they carry. In one type the left end of the chromosome of the X-Y translocation is combined with the right end of the right fragment of the X-IV translocation. The resulting chromosome must appear as a normal rod-shaped X-chromosome, and individuals carrying it must also carry two normal fourth chromosomes. Stern investigated cytologically a large number of individuals of this type and found that they had the expected type of chromosomes.

The other type of cross-overs, likewise distinguishable genetically, must have the broken X of the X-IV translocation, but the right fragment must acquire the spindle fiber end of the X of the X-Y translocation, to which the fragment of the Y is attached. The resulting individuals must have, cytologically, one rod-shaped chromosome of the length equal to one-half of the normal X (the left fragment of the X-IV translocation), a small V-shaped chromosome present in neither translocation nor in the normal flies (the right fragment of the X-IV to which the section of the Y-chromosome is now attached), and one free fourth chromosome.

Stern found that most individuals of this type actually had the predicted type of chromosomes.

Creighton and McClintock's (21) methods of investigation, as well as their findings, are in principle identical with those of Stern. These results leave no reasonable doubt that crossing over actually occurs by segmental interchange between homologous chromosomes. Any theory not assuming such an interchange has to resort to the utterly unjustifiable expedient of supposing that a chromosome may be broken in one place and may grow a hook in another place every time a phenotype of the fly shows certain mutant characteristics. Although such an attempt to evade the consequences of Stern's and McClintock's work has been actually published, it is hardly necessary to discuss it here.

GENE CHANGES ASSOCIATED WITH CHROMOSOME BREAKAGES

Translocations and inversions modify the order of the genes in the chromosomes, produce new linkage relations, and alter the mode of inheritance of the genetic factors located in the chromosomes involved. They need not, however, affect either the number or the kind of the genetic factors, and therefore individuals heterozygous or homozygous for these chromosome rearrangements should be normal in appearance and in viability. These theoretical expectations, however, are not always realized, at least not in *Drosophila*. Translocations and inversions are frequently lethal in homozygotes and some of them produce visible abnormalities in the phenotype.

The first translocation discovered in *Drosophila* (Bridges 16; Bridges and Morgan 19) produces in heterozygous condition a dominant effect on the eye color and is lethal when homozygous. Muller (72) found that a majority of induced translocations are inviable in homozygous condition. Muller's findings were corroborated by observations of Muller and Altenburg (78), Dobzhansky (25, 26, 29, 30), Dobzhansky and Sturtevant (36), Oliver (90), and of many others. Although some translocations are viable and normal in appearance in homozygous condition (Dobzhansky, 25, 29), this is, at least in *Drosophila*, the exception rather than the rule. Not infrequently translocations produce visible external effects (Muller, 75; Burkart, 20). The most remarkable fact concerning the lethal and the visible effects of chromosomal rearrangements is that these effects are, in many cases, due to the action of factors located in such close proximity to the points at which the chromosomes were broken that they fail to separate from the latter by crossing over. It appears that breakages of chromosomes are frequently associated with a peculiar kind of mutation in the genes lying immediately adjacent to the loci of the breaks (cf. Patterson, Stone, Bedichek, and Suehe, 109). An analysis of this correlation between "mutations" and

chromosome breakages constitutes an altogether new field of research in genetics. Exploration of this field has merely begun, and no firmly established conclusions have been so far arrived at. Nevertheless, some of the facts already obtained are highly suggestive.

An especially interesting group of cases is that in which chromosomes are broken close to the loci of certain known genes, causing these genes to mutate. Stern and Ogura (129) observed mutations at the bobbed locus in the *X*-chromosome of *Drosophila* that took place simultaneously with attachments of fragments of the *Y*-chromosome in the vicinity of that locus. A mutation at bobbed was also observed by Sidorov (123) in a translocation in which the *X*-chromosome is broken close to the locus of bobbed. Several duplications for sections of the *X*-chromosome including bobbed and certain genes normally located in the left end of the chromosome were studied by Sivertzev-Dobzhansky and Dobzhansky (124). Since these duplications were obtained in the offspring of wild-type males treated with X-rays, all of them should contain the wild-type allelomorph of bobbed, or should not carry the bobbed locus at all. Contrary to this expectation, the analysis of these duplications showed that none of them has the wild-type allelomorph of bobbed. Instead, allelomorphs of bobbed of various strength were found to be present. It follows that in all these duplications a mutation at the bobbed locus took place apparently simultaneously with the breakage of the chromosome in the vicinity of bobbed. Whether or not such "mutations" take place every time the chromosome is broken in that region remains to be studied. Dubinin and Sidorov (41) have described an even more remarkable case of this sort. They have studied a series of translocations involving the fourth chromosome of *Drosophila melanogaster*. These translocations were obtained by irradiating flies which were homozygous for the wild-type allelomorph of the fourth-chromosome gene cubitus interruptus; hence, the fourth chromosome in these translocations must also contain the wild-type allelomorph of this gene. Nevertheless, if flies carrying the translocations are made heterozygous for cubitus interruptus, the characteristics of this recessive gene sometimes show up, indicating that the wild-type allelomorph of it has somehow been weakened owing to the translocation. About one-half of the translocations studied by Dubinin and Sidorov show this effect, it being apparently immaterial which chromosome besides the fourth is involved in the translocation.

Muller (75), Patterson (105), Van Atta (136, 137), and Glass (43, 44, 45) found a series of dominant eye-color mutations in *Drosophila melanogaster*, most of which show patches of a differently colored tissue in the eye. A most remarkable fact is that all of these dominant eye colors are associated with some kind of chromosome rearrangements (inversions or translocations). Two groups can be distinguished among these eye-

color mutations. In the first group (Patterson and Painter, 108; Patterson 105; perhaps also Gowen and Gay, 46, 47) the presence of patches in the eye seems to be due to occasional losses of fragments of chromosomes in the cell divisions. For instance, in the "mutable translocation" described by Patterson (105) a section of the X-chromosome carrying the wild-type allelomorph of white is transposed onto the fourth chromosome. The union between this section and the fourth chromosome is, however, so weak that the former frequently drops off and is lost in the cytoplasm. If a female carrying this translocation is made heterozygous for the gene white, the cells in which the fragments are lost are white, hence the mosaicism in the eye arises.

The second group of the dominant eye colors, which is most interesting for the purposes of the present discussion, seems not to be connected with losses of fragments of chromosomes. The mutations belonging to this group produce eyes of a color different from the wild type, with or without patches of still differently colored tissue. Muller, Van Atta, and Glass (l. c.) described a series of mutations called "Plum" (or "dilute"). They are all allelomorphic to each other, and also to the second chromosome gene brown, which sometimes mutates spontaneously producing recessive eye-color changes of a more or less extreme type. In every known instance a mutation from wild type to Plum is correlated with a breakage of the second chromosome in the neighborhood of the brown locus. In at least two of the Plum allelomorphs the second chromosome carries an inversion one end of which is at brown, and the other lies in the vicinity of the spindle fiber, close to the locus of the gene light (*lt*, cf. Figs. 4 and 5). Schultz and Dobzhansky (116) have found that in these two cases Plum is allelomorphic to both brown and light. Thus, mutations have taken place at the loci of both breakages producing the inversion. It seems probable that every time such an inversion arises, mutations take place at both the brown and the light loci. According to Glass (43, 44), another dominant eye color, Grape, is allelomorphic to the third-chromosome recessive gene peach, and grape is associated with a translocation involving a breakage of the third-chromosome at peach.

The gene Bar in *Drosophila melanogaster* arose by a spontaneous mutation from wild type. This mutation has been observed only once. Mutations at this locus, consequently, must be very rare. Dobzhansky (30) found a translocation in which the X-chromosome was broken at Bar, and simultaneously with the appearance of the translocation a mutation to a recessive allelomorph of Bar, called baroid, took place. This case is remarkable because Sturtevant (130, 132) has proven that there is no wild-type allelomorph of Bar in wild-type *Drosophila*. Consequently, the mutation to baroid can not be interpreted as a loss or injury of the wild-type allelomorph of a gene located close to the locus of breakage.

Serebrovsky (118), Dubinin (38, 39), Levit (58), and Shapiro (121) have described the origin of several allelomorphs of the sex-linked recessive genes scute and yellow associated with various chromosome abnormalities, such as inversions and translocations. Unfortunately, in none of these cases is it convincingly proved that the mutations appeared in the immediate proximity to the loci of the breaks.

Changes in the genes located in the duplicating fragments of chromosomes constitute a somewhat different phenomenon. In the offspring of wild-type flies treated with X-rays individuals may be found that carry duplications for certain sections of the chromosomes. The duplicating fragments, according to their origin, should carry the wild-type allelomorph of the genes involved. It is found, however, that in many cases the genes located in duplications behave as though they had mutated (Dobzhansky and Sturtevant, 37). Thus, a duplication was found which should have included the wild-type allelomorphs of the sex-linked recessives rudimentary and forked. Nevertheless, males having a normal *X* carrying rudimentary or forked, and having the duplication, show quite clearly the effects of rudimentary and forked, respectively, in their phenotypes. Likewise, rudimentary and forked manifest themselves in females having two normal *X*'s with these genes and the duplication. The wild-type allelomorphs of rudimentary and forked are, however, known to be almost completely dominant over one or even two doses of the corresponding recessives. The behavior of these wild-type allelomorphs when located in the duplicating fragments, indicates, then, that their functioning is somewhat changed by the occurrence of breakages in their vicinity (cf. Dubinin and Sidorov, 41). An alternative explanation of this fact may be that the change in the behavior of these genes is due to a disturbance of the normal genic balance produced by the duplications.

Why should chromosome breakages so frequently be associated with mutations in the neighboring genes? Several possible explanations of this fact may be suggested. Perhaps the simplest one was advanced by Bridges (Morgan, Bridges, Sturtevant, 71). Chromosome breakages may be provoked by a destruction of certain genes in the chromosome. The chromosome is, so to say, weakened in this place, its continuity may easily be disrupted, and the breakage is accomplished. The "mutations" at the breakage points are, then, deficiencies, losses, of genes. The application of this explanation to most of the known cases of "mutations" associated with breakages meets with no insuperable difficulty. There is nothing surprising in this, since the same "explanation" may be applied with equal ease to most of the spontaneous and induced gene mutations as well (Serebrovsky, 117). The difficulty comes, however, as soon as one tries to adduce specific evidence in favor of this hypothesis. The known deficiencies possess certain character-

istic properties (Bridges, Mohr): they produce an exaggeration of the effects of the genes induced, they behave as the most extreme known allelomorphs of these genes, and they frequently include the loci of more than one neighboring gene. In cases in which these criteria could have been applied to mutations associated with breakages (Schultz and Dobzhansky, 116) the results were consistently negative. The case of baroid (see above) seems to be directly contradictory to the deficiency explanation. According to Sturtevant (130, 132) there is no wild-type allelomorph of Bar. A mutation from wild-type to an allelomorph of Bar is, hence, an addition rather than a loss.

The second explanation is, likewise, purely formal. Gene mutations may take place simultaneously with breakages. Oliver (90) examined the statistical consequences of this explanation and came to the conclusion that mutation at loci closely adjacent to breakages takes place more frequently than it might be expected on a chance basis. One is therefore, forced to assume that the occurrence of breakages increases the probability of mutations taking place in the neighboring loci. In such a form the hypothesis becomes a mere restatement of the facts. If, as seems probable in certain Plum allelomorphs, a definite chromosome rearrangement is always correlated with a definite mutation (Schultz and Dobzhansky, 116), this explanation begs the question.

The third explanation assumes that the functioning of a gene depends on its structure as well as on the structure of its neighbors. The adjacent genes in the chromosomes may not be totally independent of each other. The genes *A*, *B*, and *C* may produce an effect which we call "normal" when they are arranged in the order *ABC*, and a different effect in case the order becomes *CAB*. Such a rearrangement deprives each of these genes of the neighbors with which they are usually associated, and gives them new neighbors which are normally located in a different part of the same chromosome, or even in a different chromosome. Either the rupture of the normal intergenic connections, or the establishing of the new ones, or both, may alter the functioning of the genes. Any chromosome rearrangement obviously involves such changes in the surroundings of the genes located at the breakage points. Mutations at the loci of breakages are, then, due to "position effect."

Position effect is not a new principle invoked specially to explain the association of mutations with breakages. Sturtevant (130, 132) has firmly established the existence of a position effect in the case of Bar. Two Bar genes located in the same chromosome (double Bar) are more effective than the same two Bar genes located in different chromosomes. Neither the deficiency explanation nor the mutation hypothesis is applicable to the Bar case of Sturtevant. Sturtevant clearly foresaw the possibility of finding further instances of position effect by studying chromosomal rearrangements, predicting in a sense the association of

mutations with chromosome breakages. Muller and Altenburg (78), Dobzhansky (30), Dobzhansky and Sturtevant (37), and Sivertzev-Dobzhansky and Dobzhansky (124) discussed the applications of the position-effect hypothesis in more detail. The association of definite mutations with definite chromosome rearrangements (Sivertzev-Dobzhansky and Dobzhansky, 124; Schultz and Dobzhansky, 116) is the strongest evidence in favor of this hypothesis.

The nature of position effect is not clear at the present. In fact, an understanding of its nature presupposes a knowledge of the nature of the gene. *Mutatis mutandis*, further studies on position effect are probably the most promising mode of attack on the problem of the gene, perhaps the most fundamental problem of genetics. Among many questions which require investigation, one is, perhaps, outstanding: Are only the genes immediately adjacent to the loci of breaks subject to position effect, or may the function of genes lying at a certain, though small, distance from the breakage also be changed? The alteration of the effects of the genes lying in the duplicating fragments (see above) seems to argue in favor of the latter possibility, but, unfortunately, it is exactly in these cases that the proof of these alterations being due to position effect (and not to disturbances in the genic balance) presents greatest difficulties. If only the genes lying at the breakage points were changed, this would argue in favor of the existence of intimate intergenic connections, perhaps of the nature of chemical bonds of some sort between the molecules representing genes. It would be then convenient to picture the gene string in the chromosome as a chain of dissimilar molecules, somewhat similar to the cellulose fibril, the links of the chain being connected by definite bonds. If the position effect extends for a relatively considerable distance from the breakage, the foregoing possibility is not excluded, but then, perhaps the phenomenon is more easily accounted for by supposing that the products elaborated by the genes react immediately after being freed, the distances between the sources of these products being of some consequence.

MECHANISM OF MEIOSIS

Up to a relatively recent date the process of meiosis was studied primarily by determining cytologically the behavior of chromosomes in gametogenesis of various species of animals and plants. Individuals having normal chromosomes were usually selected for investigation. This method of approach is essentially descriptive, observational, and comparative. A wealth of valuable data was secured by this method: the normal seriation of the different stages of meiosis became known; the essential similarity of meiosis in widely dissimilar organisms was revealed; a functional correlation between the cytological processes and their genetic consequences established. The discovery of chromo-

somal aberrations in general, and of chromosome rearrangements in particular, opened the possibility of an experimental attack on the problems of the mechanism of meiosis. Chromosomal aberrations produce characteristic disturbances of the different stages of meiosis. A comparative genetic, and, where possible, also a comparative cytological investigation of individuals carrying chromosomal aberrations and of those having normal chromosomes reveals a series of facts which are probably very important for a causal analysis of the processes involved.

Crossing over between the normal and rearranged chromosomes is characteristically affected in individuals heterozygous for translocations or inversions. The frequency of crossing over is, at least in *Drosophila*, almost invariably reduced in such individuals as compared with normal ones, although the extent of reduction is extremely variable, ranging from a complete suppression to an approximate normality of crossing over. This reduction of crossing over is subject to a series of general rules, the existence of which suggests that the whole phenomenon is due to the action of comparatively few equally general causes.

Inverted section heterozygotes show a reduction of crossing over not only within the limits of the inversion (where only doubles are observed) but also on both sides of it (Sturtevant 131, 133). The degree of the reduction becomes progressively smaller the farther an interval is removed from the ends of the inversion. In V-shaped autosomes of *Drosophila* inversions affect crossing over only in the limb in which they lie and not in the opposite limb. In individuals homozygous for inverted sections the reduction of crossing over disappears (Sturtevant, 133).

In heterozygous translocations a reduction of crossing over is observed in all the chromosomes involved, in donors as well as in the recipients. The relatively greatest reduction is found in the intervals in which the loci of breakages or attachments are located, and in the adjacent intervals. The farther an interval is removed from these loci the more nearly normal is the frequency of crossing over therein. If the breakage is located in one of the limbs of a V-shaped chromosome, crossing over is affected in that limb only, not in the other limb. If, however, a breakage takes place at or very close to the spindle attachment, crossing over is affected to a certain extent in both limbs (Dobzhansky and Sturtevant, 36; Dobzhansky 34).

The degree of reduction in the frequency of crossing over is a function of the relative lengths of the transferred or exchanged sections of the chromosomes. Crossing over is frequently almost totally suppressed in small sections of chromosomes attached to other much longer chromosomes, while in the latter it is normal or nearly so. The longer the attached section, and the shorter the chromosome (or the fragment) to which it is attached, the more nearly normal is crossing over in the

attached section, and the stronger is the reduction of crossing over in the recipient. The reduction of crossing over in the donor is strongest if a section of a certain intermediate length is transferred to another chromosome; donors which have lost very short or very long sections may show approximately normal crossing over (Dobzhansky, 28, 32, 34).

The occurrence of crossing over between homologous chromosomes or their fragments increases the probability of their normal disjunction, that is, of their passing to the opposite poles of the spindle at the reduction division. Chromosomes which have not crossed over are likely to undergo nondisjunction, *i.e.*, to be distributed at random in respect to their homologues at the reduction division (Bridges, 12; Anderson, 6; Dobzhansky, 34). Since in translocations the frequency of crossing over is a function of the relative lengths of the fragments of the donor and the recipient chromosomes (see above), there exists a functional connection between the latter variables and the mode of the disjunction of the chromosomes involved in a translocation (Dobzhansky, 30, 34).

All the regularities mentioned before can be brought into a self-consistent system if one assumes that: (a) the pairing of the homologous loci of the chromosomes at meiosis is due to a mutual attraction exhibited by these loci (Dobzhansky, 28), (b) the frequency of crossing over at a given point is a function of the distance between that point and the spindle attachment (Beadle, 8; Offerman, Stone and Muller, 86), and (c) the occurrence of crossing over is related to the presence of chiasmata between the chromosomes, the presence of chiasmata regulating the position of the chromosomes on the spindle at the reduction division, and, consequently, the disjunction of the chromosomes (Darlington, 21a).

In individuals having normal chromosomes every chromosome has one and only one complete homologue, *i.e.*, there exist only two chromosomes in the nucleus which carry the same genes arranged in the same order. The mutual attraction of the loci contained in these chromosomes brings them together at meiosis, the chromosomes pair, undergo crossing over, and disjoin normally at the reduction division. Chromosome rearrangements disturb the normal pairing owing to the competition between the different loci and parts of the chromosomes. In heterozygous translocations some chromosomes consist of parts which are homologous to two (or more) different chromosomes in the same nucleus. Such chromosomes (considered as wholes) are attracted simultaneously toward more than one partial homologue. Competition between the different sections each of which tends to pair with its own homologue leads to a failure, or at least to a delay, of pairing of some sections. This obviously prevents, or reduces the probability of, crossing over taking place in the sections whose pairing was delayed and thereby disturbs their disjunction.

The most acute conflict of the attraction forces should ensue in the vicinity of the points where the chromosomes change their homologies.

The strong reduction of the frequency of crossing over in the neighborhood of the breakage and attachment points (page 1198) is the consequence. Short sections of chromosomes attached to long nonhomologous chromosomes are, all other conditions being equal, weak competitors. The pairing of such sections with their homologues is most likely to be delayed or not attained at all, hence the strong reduction of crossing over in these sections, and little or no reduction in the chromosomes to which they are attached (see page 1199).

The validity of this interpretation of the reduction of crossing over observed in individuals heterozygous for translocations and inversions was tested in a variety of ways. A cytological investigation of the chromosomes of *Drosophila* in the prophase stages of meiosis has so far not been found possible on account of the extreme technical difficulties presented by this object. Such an investigation, however, was carried through in a plant object, namely, in *Zea Mays*, by McClintock (65, 66). In maize, in contradistinction to *Drosophila*, little or no reduction of crossing over is produced by most of the heterozygous chromosome rearrangements. In a full agreement with this stands the fact, discovered by McClintock, that in most heterozygous translocations in maize the pairing of all the homologous sections of the chromosomes involved is complete or nearly so. On the other hand, in some translocations and inversions in maize some sections of the chromosomes fail to pair with their homologues, and, instead, either remain unpaired, or show a peculiar pairing with nonhomologous sections, which, as far as the genetic consequences are concerned, is equivalent to a lack of pairing. McClintock found furthermore that the failure of normal pairing is most frequently observed in the parts of the chromosomes immediately adjacent to the loci of the breakages and reattachments, that in case a translocation involves an exchange of very unequal sections the short sections fail to pair much more frequently than the long ones, that in inversions involving short sections of chromosomes the inverted part fails to pair, and in those involving very long sections the noninverted part is more likely not to attain normal pairing. It is easy to see how nicely these findings agree with the genetic facts discovered in *Drosophila*.

A series of genetic tests of the hypothesis of competitive pairing was devised. This hypothesis requires that if the attraction of one of the competing sections toward its homologue is decreased by some factor, the sections which are the competitors of the former should pair more successfully, and, consequently, the frequency of crossing over in the latter sections should rise, while the frequency of nondisjunction should decrease. Dobzhansky and Sturtevant (133) and Dobzhansky (34) actually found that if crossing over between some sections of the chromosomes involved in a translocation is prevented by introduction of inversions, the frequency of crossing over in other sections increases sharply.

Simultaneously, the frequency of nondisjunction of the sections in which crossing over is prevented is increased, and that of the other sections becomes rare.

In a series of translocations involving transfers of sections of the second chromosome of *Drosophila* to the Y-chromosome the effect of inversions was found to depend upon the relative position of the inversion in respect to the breakage point. If the inversion is homologous to the part of the second chromosome attached to the Y, the frequency of crossing over in the part of the second chromosome remaining free is increased. On the other hand, if the inversion is homologous to the part of the second chromosome remaining free, crossing over in the part attached to the Y increases strikingly. The frequency of nondisjunction was found to be inversely proportional to that of crossing over. These facts cannot be reasonably interpreted otherwise than as corroborating the hypothesis of competitive pairing (Dobzhansky, 32).

Another corollary of the competitive pairing hypothesis is that the presence of duplicating fragments of chromosomes should have an effect on crossing over in the chromosomes to which the fragments are homologous. Individuals may be obtained which have the normal diploid set of chromosomes plus a duplication for a section of one of the chromosomes. Since the duplication should tend to pair with either of its two normal partial homologues, the pairing of the latter with each other should be disturbed, and the frequency of crossing over in them should be decreased. Thus, a reduction of the frequency of crossing over is expected to take place in chromosomes which are not themselves involved in any chromosome aberration. Rhoades (113) studied crossing over in the normal second chromosomes in the presence of a duplication for a section of the same chromosome. A reduction of the frequency of crossing over was found. Dobzhansky (in press) found the same to be true for a series of duplications for sections of the X-chromosome of *Drosophila melanogaster*, the strength of the reduction being a function of the length of the duplicating sections.

Beadle (8) and Offermann, Stone, and Muller (86), however, discovered the existence of a factor other than competitive pairing that accounts for a part of the reduction of crossing over observed in translocations. In individuals homozygous for translocations the conditions of the chromosome pairing are, as far as competition of chromosomes is concerned, similar to the conditions found in normal individuals. Nevertheless, the frequency of crossing over is found to be very different from normal in certain intervals of the chromosomes. The only explanation of this fact is that a change in the relation of the chromosome segments in respect to the spindle attachment may alter the frequency of crossing over in that segment. As shown before, the cytological maps of the *Drosophila* chromosomes indicate that crossing over in all chromosomes

is low in frequency in the vicinity of the spindle attachments. The results of Beadle and of others who have studied the linkage relations in individuals homozygous for chromosome rearrangements prove then that the distribution of crossing over along the chromosomes (as studied through the cytological maps) is not a property of the substance of the chromosome located in its various parts, but rather the result of the mechanical relationship leading to crossing over, in which the spindle attachment plays a role.

REFERENCES

1. ALBERTI, W., and G. POLITZER. Über den Einfluss der Röntgenstrahlen auf die Zellteilung. *Arch. Mikrosk. Anat. und Entwicklungsmech.* **100**: 83-109. 1923.
2. ALBERTI, W., and G. POLITZER. Über den Einfluss der Röntgenstrahlen auf die Zellteilung. II. *Arch. Mikrosk. Anat. und Entwicklungsmech.* **103**: 284-307. 1924.
3. ANDERSON, E. G. X-rays and the frequency of non-disjunction in *Drosophila*. *Michigan Acad. Sci.* **4**: 523-525. 1924.
4. ANDERSON, E. G. Crossing over in a case of attached X-chromosomes in *Drosophila melanogaster*. *Genetics* **10**: 403-417. 1925.
5. ANDERSON, E. G. The proportion of exceptions in the offspring of exceptional females from X-ray treatment in *Drosophila*. *Michigan Acad. Sci.* **5**: 355-356. 1925.
6. ANDERSON, E. G. Studies on a case of high non-disjunction in *Drosophila melanogaster*. *Zeitsch. Indukt. Abstamm. und Vererb.* **51**: 397-441. 1929.
7. ANDERSON, E. G. The constitution of primary exceptions obtained after X-ray treatment of *Drosophila*. *Genetics* **16**: 386-396. 1931.
8. BEADLE, G. W. A possible influence of the spindle fibre on crossing over in *Drosophila*. *Proc. Nation. Acad. Sci.* **18**: 160-165. 1932.
9. BELLING, J. Configuration of bivalents of Hyacinthus with regard to segmental interchange. *Biol. Bull.* **52**: 480-487. 1927.
10. BELLING, J., and A. F. BLAKESLEE. On the attachment of non-homologous chromosomes at the reduction division in certain 25-chromosome *Daturas*. *Proc. Nation. Acad. Sci.* **12**: 7-11. 1926.
11. BOLEN, H. R. A mutual translocation involving the fourth and the X-chromosomes of *Drosophila*. *Amer. Nat.* **65**: 417-422. 1931.
12. BRIDGES, C. B. Non-disjunction as proof of the chromosome theory of heredity. *Genetics* **1**: 1-52, 107-163. 1916.
13. BRIDGES, C. B. Deficiency. *Genetics* **2**: 445-465. 1917.
14. BRIDGES, C. B. Duplication. *Anat. Rec.* **15**: 357-358. 1919.
15. BRIDGES, C. B. Genetical and cytological proof of non-disjunction of the fourth chromosome of *Drosophila melanogaster*. *Proc. Nation. Acad. Sci.* **7**: 186-192. 1921.
16. BRIDGES, C. B. The translocation of a section of chromosome II upon chromosome III in *Drosophila*. *Anat. Rec.* **24**: 426. 1923.
17. BRIDGES, C. B. Aberrations in chromosomal materials. *Eugenics, Genetics and the Family* **1**: 76-81. 1923.
18. BRIDGES, C. B. Constrictions in the chromosomes of *Drosophila melanogaster*. *Biol. Zentralbl.* **47**: 600-603. 1927.
19. BRIDGES, C. B., and T. H. MORGAN. The third chromosome group of mutant characters of *Drosophila melanogaster*. *Carnegie Instn. Washington Publ.* **327**: 1-251. 1923.

20. BURKART, A. Investigaciones geneticas sobre una nueva mutacion de *Drosophila melanogaster* determinante de excepciones hereditarias. *Revista de la Facult. Agron. Veterin.* **2**: 393-490. 1931.
21. CREIGHTON, H. B., and B. McCLINTOCK. A correlation of cytological and genetic crossing over in *Zea mays*. *Proc. Nation. Acad. Sci.* **17**: 492-497. 1931.
- 21a. DARLINGTON, C. D. *Recent advances in cytology.* Blakiston's; Philadelphia, 1932.
22. DEMEREC, M., and J. G. FARROW. Non-disjunction of the X-chromosomes in *Drosophila virilis*. *Proc. Nation. Acad. Sci.* **16**: 707-710. 1930.
23. DEMEREC, M., and J. G. FARROW. Relation between the X-ray dosage and the frequency of primary non-disjunction of X-chromosomes in *Drosophila virilis*. *Proc. Nation. Acad. Sci.* **16**: 711-714. 1930.
24. DOBZHANSKY, TH. Genetical and cytological proof of translocations involving the third and the fourth chromosomes of *Drosophila melanogaster*. *Biol. Zentralbl.* **49**: 408-419. 1929.
25. DOBZHANSKY, TH. A homozygous translocation in *Drosophila melanogaster*. *Proc. Nation. Acad. Sci.* **15**: 633-638. 1929.
26. DOBZHANSKY, TH. Translocations involving the third and the fourth chromosomes of *Drosophila melanogaster*. *Genetics* **15**: 347-399. 1930.
27. DOBZHANSKY, TH. Cytological map of the second chromosome of *Drosophila melanogaster*. *Biol. Zentralbl.* **50**: 671-685. 1930.
28. DOBZHANSKY, TH. The decrease of crossing over observed in translocations, and its probable explanation. *Amer. Nat.* **65**: 214-232. 1931.
29. DOBZHANSKY, TH. Translocations involving the second and the fourth chromosomes of *Drosophila melanogaster*. *Genetics* **16**: 629-658. 1931.
30. DOBZHANSKY, TH. The baroid mutation in *Drosophila melanogaster*. *Genetics* **17**: 369-392. 1932.
31. DOBZHANSKY, TH. Cytological map of the X-chromosome of *Drosophila melanogaster*. *Biol. Zentralbl.* **52**: 495-509. 1932.
32. DOBZHANSKY, TH. Studies on chromosome conjugation. I. *Zeitsch. Indukt. Abstamm. und Vererbungsl.* **60**: 235-286. 1932.
33. DOBZHANSKY, TH. Deletion of a section of the X-chromosome of *Drosophila melanogaster*. *Bull. Labor. Genetics, Leningrad* **9**: 193-216. 1932.
34. DOBZHANSKY, TH. Studies on chromosome conjugation. II. *Zeitsch. Indukt. Abstamm. und Vererbungsl.* **64**: 269-309. 1933.
35. DOBZHANSKY, TH., and J. SCHULTZ. Evidence for multiple sex factors in the X-chromosome of *Drosophila melanogaster*. *Proc. Nation. Acad. Sci.* **17**: 513-518. 1931.
36. DOBZHANSKY, TH., and A. H. STURTEVANT. Translocations between the second and third chromosomes of *Drosophila* and their bearing on *Oenothera* problems. *Carnegie Instn. Washington Publ.* **421**: 29-59. 1931.
37. DOBZHANSKY, TH., and A. H. STURTEVANT. Change in dominance of genes lying in duplicating fragments of chromosomes. *Proc. VI Internat. Congr. Gen.* **2**: 45-46. 1932.
38. DUBININ, N. P. Studies on the phenomenon of step-allelomorphism in *Drosophila melanogaster*. I. *Jour. Exp. Biol. (Russian)* **5**: 53-85. 1929.
39. DUBININ, N. P. Allelomorphentreppen bei *Drosophila melanogaster*. *Biol. Zentralbl.* **49**: 328-339. 1929.
40. DUBININ, N. P. On the origin of deleted X-chromosomes. *Jour. Exp. Biol. (Russian)* **6**: 365-368. 1930.
41. DUBININ, N. P., and B. N. SIDOROFF. Relation between the effect of a gene and its position in the system. *Amer. Nat.* **68**: 377-381. 1934.

42. FRIESEN, H. Artificially induced crossing over in males of *Drosophila melanogaster*. *Science* **78**: 513-514. 1933.
43. GLASS, H. B. A study of dominant mosaic eye-color mutants in *Drosophila*. *Proc. VI Internat. Congr. Genet.* **2**: 62-63. 1932.
44. GLASS, H. B. A study of dominant mosaic eye color mutants in *Drosophila melanogaster*. II. *Jour. Genet.* **28**: 69-112. 1933.
45. GLASS, H. B. A study of dominant mosaic eye color mutants in *Drosophila melanogaster*. I. *Amer. Nat.* **68**: 107-114. 1934.
46. GOWEN, J. W., and E. H. GAY. On eversporting as a function of the Y chromosome in *Drosophila melanogaster*. *Amer. Nat.* **67**: 68. 1933.
47. GOWEN, J. W., and E. H. GAY. Eversporting as a function of the Y chromosome in *Drosophila melanogaster*. *Proc. Nation. Acad. Sci.* **19**: 122-126. 1933.
48. GREB, R. J. Effects of X-radiation on production of mosaic males and on sex-ratio in *Habrobracon*. *Amer. Nat.* **67**: 88-93. 1933.
49. HEITZ, E. Über totale und partielle somatische Heteropyknose, sowie strukturelle Geschlechtschromosomen bei *Drosophila funebris*. *Zeitsch. Zellforsch. und Mikr. Anat.* **19**: 720-742. 1933.
50. HEITZ, E. Die somatische Heteropyknose bei *Drosophila melanogaster* und ihre genetische Bedeutung. *Zeitsch. Zellforsch. und Mikr. Anat.* **20**: 237-287. 1933.
51. HEITZ, E., and H. BAUER. Beweise für die Chromosomennatur der Kernschleifen in den Knäuelkernen von *Bibio hortulanus*. *Zeitsch. Zellforsch. und Mikr. Anat.* **17**: 67-82. 1933.
52. HELWIG, E. R. The effect of X-rays on the chromosomes of *Circotettix veruculatus* (Orthoptera). *Amer. Nat.* **67**: 62. 1933.
53. HERTWIG, P. Durch Radiumbestrahlung hervorgerufene Veränderungen in den Kernteilungsfiguren der Eier von *Ascaris megalocephala*. *Arch. Mikrosk. Anat.* **77**: 301-312. 1911.
54. JUST, E. E. A cytological study of effects of ultra-violet light on the egg of *Nereis limbata*. *Zeitsch. Zellforsch. und Mikr. Anat.* **17**: 25-50. 1933.
55. KAUFMANN, B. P. Interchange between X- and Y-chromosomes in attached X females of *Drosophila melanogaster*. *Proc. Nation. Acad. Sci.* **19**: 830-838. 1933.
56. KAUFMANN, B. P. Somatic mitoses of *Drosophila melanogaster*. *Jour. Morphol.* **56**: 125-155. 1934.
57. LEVAN, A. Cytological studies in *Allium*. II. *Hereditas* **16**: 257-294. 1932.
58. LEVIT, S. G. Step-allelomorphism in *Drosophila melanogaster*. V. *Jour. Exp. Biol. (Russian)* **6**: 287-299. 1930.
59. LEWITSKY, G. A., and A. G. ARARATIAN. Transformations of chromosomes under the influence of X-rays. *Bull. Appl. Bot., Genetics, Plant Breeding* **27**: 256-303. 1931.
60. LI, J. C. The effect of chromosome aberrations on development in *Drosophila melanogaster*. *Genetics* **12**: 1-58. 1927.
61. MAVOR, J. W. The production of non-disjunction by X-rays. *Science* **55**: 295-297. 1922.
62. MAVOR, J. W. The production of non-disjunction by X-rays. *Jour. Exp. Zool.* **39**: 381-432. 1924.
63. MAVOR, J. W. Gynandromorphs from X-rayed mothers. *Amer. Nat.* **58**: 525-529. 1924.
64. MAVOR, J. W. The effect on crossing over and non-disjunction of X-raying the anterior and the posterior halves of *Drosophila* pupae. *Genetics* **14**: 129-159. 1929.

65. McCLINTOCK, B. Cytological observation in *Zea* on the intimate association of non-homologous parts of chromosomes in the midprophase of meiosis and its relation to diakinesis configurations. *Proc. VI Internat. Congr. Genet.* **2**: 126-128. 1932.
66. McCLINTOCK, B. The association of non-homologous parts of chromosomes in the mid-prophase of meiosis in *Zea mays*. *Zeitsch. Zellforsch. und Mikr. Anat.* **19**: 344-366. 1934.
67. MOHR, O. L. Mikroskopische Untersuchungen zu Experimenten über den Einfluss der Radiumstrahlen und der Kältewirkung auf die Chromatinreifung und das Heterochromosom bei *Deeticus verrucivorus*. *Arch. Mikrosk. Anat.* **92**: 300-368. 1919.
68. MOHR, O. L. Genetical and cytological proof of somatic elimination of the fourth chromosome in *Drosophila melanogaster*. *Genetics* **17**: 60-80. 1932.
69. MORGAN, L. V. Non-criss-cross inheritance in *Drosophila melanogaster*. *Biol. Bull.* **42**: 267-274. 1922.
70. MORGAN, L. V. Polyploidy in *Drosophila melanogaster* with two attached X-chromosomes. *Genetics* **10**: 148-178. 1925.
71. MORGAN, T. H., C. B. BRIDGES, and A. H. STURTEVANT. The genetics of *Drosophila*. *Bibliog. Genet.* **2**: 1-262. 1925.
72. MULLER, H. J. The problem of genic modification. *Zeitsch. Indukt. Abstamm. und Vererbungsl. Suppl.* **1**: 234-260. 1928.
73. MULLER, H. J. The production of mutations by X-rays. *Proc. Nation. Acad. Sci.* **14**: 714-726. 1928.
74. MULLER, J. H. The first cytological demonstration of a translocation in *Drosophila*. *Anat. Rec.* **63**: 481-486. 1929.
75. MULLER, J. H. Types of visible variations induced by X-rays in *Drosophila*. *Jour. Genet.* **22**: 299-334. 1930.
76. MULLER, J. H. Oenothera-like linkage of chromosomes in *Drosophila*. *Jour. Genet.* **22**: 335-357. 1930.
77. MULLER, H. J., and E. ALTENBURG. Chromosome translocations produced by X-rays in *Drosophila*. *Anat. Rec.* **61**: 100. 1928.
78. MULLER, H. J., and E. ALTENBURG. The frequency of translocations produced by X-rays in *Drosophila*. *Genetics* **15**: 283-311. 1930.
79. MULLER, H. J., and A. L. DIPPEL. Chromosome breakage by X-rays and the production of eggs from genetically male tissue in *Drosophila*. *British Jour. Exp. Biol.* **3**: 85-122. 1926.
80. MULLER, H. J., and T. S. PAINTER. The cytological expression of changes in gene alignment produced by X-rays in *Drosophila*. *Amer. Nat.* **63**: 193-200. 1929.
81. MULLER, H. J., and T. S. PAINTER. The differentiation of the sex chromosomes of *Drosophila* into genetically active and inert regions. *Zeitsch. Indukt. Abstamm. und Vererbungsl.* **62**: 316-365. 1932.
82. MULLER, H. J., and W. S. STONE. Analysis of several induced gene rearrangements involving the X-chromosome of *Drosophila*. *Anat. Rec.* **47**: 393-394. 1930.
83. NABOURS, R. K. An X-ray induced chromosomal translocation in *Apotettix eurycephalus* Hancock. *Anat. Rec.* **51**: 111-112. 1931.
84. NABOURS, R. K., and W. R. B. ROBERTSON. An X-ray induced chromosomal translocation in *Apotettix eurycephalus* Hancock (Grouse locusts). *Proc. Nation. Acad. Sci.* **19**: 234-239. 1933.
85. OFFERMANN, C. A., and H. J. MULLER. Regional differences in crossing over as a function of the chromosome structure. *Proc. VI Internat. Congr. Genet.* **2**: 143-145. 1932.

86. OFFERMANN, C., W. S. STONE, and H. J. MULLER. Causes of interregional differences in crossing over frequency, studied in individuals homozygous for gene rearrangements. *Anat. Rec.* **51**: 109. 1931.
87. OLIVER, C. P. The effect of varying the duration of X-ray treatment upon frequency of mutations. *Science* **71**: 44-46. 1930.
88. OLIVER, C. P. Complex gene rearrangements induced by X-rays. *Anat. Rec.* **47**: 385. 1930.
89. OLIVER, C. P. Chromosomal aberrations and X-ray dosage. *Anat. Rec.* **51**: 110. 1931.
90. OLIVER, C. P. An analysis of the effect of varying the duration of X-ray treatment upon the frequency of mutations. *Zeitsch. Indukt. Abstamm. und Vererbungsl.* **61**: 447-488. 1932.
91. OLIVER, C. P., and E. W. VAN ATTA. Genetic and cytological correlation of chromosomal aberrations of *Drosophila*. *Proc. VI Internat. Congr. Genet.* **2**: 145-147. 1932.
92. PAINTER, T. S. The chromosome constitution of Gates' "non-disjunction" (*v - o*) mice. *Genetics* **12**: 379-392. 1927.
93. PAINTER, T. S. A cytological map of the X-chromosome of *Drosophila melanogaster*. *Science* **73**: 647-648. 1931.
94. PAINTER, T. S. A cytological map of the X-chromosome in *Drosophila melanogaster*. *Anat. Rec.* **51**: 111. 1931.
95. PAINTER, T. S. A new method for the study of chromosome rearrangements and the plotting of chromosome maps. *Science* **78**: 585-586. 1933.
96. PAINTER, T. S. A new method for the study of chromosome aberrations and the plotting of chromosome maps in *Drosophila melanogaster*. *Genetics* **19**: 175-188. 1934.
97. PAINTER, T. S. The morphology of the X-chromosome in salivary glands of *Drosophila melanogaster* and a new type of chromosome map for this element. *Genetics* **19**: 448-469. 1934.
98. PAINTER, T. S., and H. J. MULLER. The parallel cytology and genetics of induced translocations and deletions in *Drosophila*. *Jour. Hered.* **20**: 287-298. 1929.
99. PAINTER, T. S., and H. J. MULLER. A cytological map of the X-chromosome of *Drosophila*. *Proc. VI Internat. Congr. Genet.* **2**: 147-148. 1932.
100. PATTERSON, J. T. The production of mosaics in *Drosophila* by X-rays. *Anat. Rec.* **47**: 394-395. 1930.
101. PATTERSON, J. T. Proof that the entire chromosome is not eliminated in the production of somatic variations by X-rays in *Drosophila*. *Genetics* **16**: 141-149. 1930.
102. PATTERSON, J. T. The question of a primary sex factor in the X-chromosome of *Drosophila melanogaster*. *Anat. Rec.* **51**: 111. 1931.
103. PATTERSON, J. T. The production of gynandromorphs in *Drosophila melanogaster* by X-rays. *Jour. Exp. Zool.* **60**: 173-211. 1931.
104. PATTERSON, J. T. A gene for viability in the X-chromosome of *Drosophila*. *Zeitsch. Indukt. Abstamm. und Vererbungsl.* **60**: 125-136. 1931.
105. PATTERSON, J. T. A new type of mottled-eyed *Drosophila* due to an unstable translocation. *Genetics* **17**: 38-59. 1932.
106. PATTERSON, J. T. The mechanism of mosaic formation in *Drosophila*. *Proc. VI Internat. Congr. Genet.* **2**: 153-155. 1932.
107. PATTERSON, J. T. The mechanism of mosaic formation in *Drosophila*. *Genetics* **18**: 32-52. 1933.
108. PATTERSON, J. T., and T. S. PAINTER. A mottled-eyed *Drosophila*. *Science* **73**: 530-531. 1931.

109. PATTERSON, J. T., W. STONE, S. BEDICHEK, and M. SUCHE. The production of translocations in *Drosophila*. *Amer. Nat.* **68**: 359-369. 1934.
110. PATTERSON, J. T., and M. L. SUCHE. Crossing over induced by X-rays in males. *Genetics* **19**: 223-236. 1934.
111. REDFIELD, H. Crossing over in the third chromosome of triploids of *Drosophila melanogaster*. *Genetics* **15**: 205-252. 1930.
112. REDFIELD, H. A comparison of triploid and diploid crossing over for chromosome II of *Drosophila melanogaster*. *Genetics* **17**: 137-152. 1932.
113. RHOADES, M. M. A new type of translocation in *Drosophila melanogaster*. *Genetics* **16**: 490-504. 1931.
114. ROBERTSON, W. R. B. A permanent chromosomal translocation induced by X-rays in *Apotettix eurycephalus* Hancock. *Anat. Rec.* **51**: 120. 1931.
115. SCHULTZ, J. X-ray effects on *Drosophila pseudoobscura*. *Genetics* **18**: 284-291. 1933.
116. SCHULTZ, J., and TH. DORZHANSKY. The relation of a dominant eye color in *Drosophila* to the associated chromosome rearrangement. *Genetics* **19**: 344-364. 1934.
117. SEREBROVSKY, A. S. A general scheme for the origin of mutations. *Anat. Rec.* **63**: 347-378. 1929.
118. SEREBROVSKY, A. S. Studies on the step-allelomorphism. IV. *Jour. Exp. Biol. (Russian)* **6**: 61-72. 1930.
119. SEREBROVSKY, A. S., and N. P. DUBININ. X-ray experiments with *Drosophila*. *Jour. Hered.* **21**: 259-265. 1930.
120. SEREBROVSKY, A. S., N. P. DUBININ, I. I. AGOL, W. N. SLIEPKOFF, and W. E. ALTSHULER. The origin of mutations through the influence of X-rays in *Drosophila melanogaster*. *Jour. Exp. Biol. (Russian)* **4**: 161-180. 1928.
121. SHAPIRO, N. I. Step-allelomorphism in *Drosophila melanogaster*. VII. *Jour. Exp. Biol. (Russian)* **6**: 347-364. 1930.
122. SHAPIRO, N. I. The influence of the age of germ cells on the origin of translocations in *Drosophila melanogaster*. *Jour. Exp. Biol. (Russian)* **7**: 340-348. 1931.
123. SIDOROV, B. N. A new allelomorph of bobbed connected with a translocation from the right half of the X-chromosome in *Drosophila melanogaster*. *Jour. Exp. Biol. (Russian)* **7**: 15-27. 1931.
124. SIVERTZEV-DORZHANSKY, N. P., and TH. DORZHANSKY. Deficiency and duplications for the gene bobbed in *Drosophila melanogaster*. *Genetics* **18**: 173-192. 1933.
125. SNELL, G. D. Genetic changes in mice induced by X-rays. *Amer. Nat.* **67**: 81. 1933.
126. STERN, C. Eine neue Chromosomenaberration von *Drosophila melanogaster* und ihre Bedeutung für die Theorie der linearen Anordnung der Gene. *Biol. Zentralbl.* **46**: 505-508. 1926.
127. STERN, C. Untersuchungen über Aberrationen des Y-Chromosoms von *Drosophila melanogaster*. *Zeitsch. Indukt. Abstamm. und Vererbungslehre* **51**: 253-353. 1929.
128. STERN, C. Zytologisch-genetische Untersuchungen als Beweise für die Morgansche Theorie des Factorenaustauschs. *Biol. Zentralbl.* **51**: 547-587. 1931.
129. STERN, C., and S. OGURA. Neue Untersuchungen über Aberrationen des Y-Chromosoms von *Drosophila melanogaster*. *Zeitsch. Indukt. Abstamm. und Vererbungslehre* **58**: 81-121. 1931.
130. STURTEVANT, A. H. The effect of unequal crossing-over at the Bar locus in *Drosophila*. *Genetics* **10**: 117-147. 1925.

131. STURTEVANT, A. H. A cross-over reducer in *Drosophila melanogaster* due to inversion of a section of the third chromosome. *Biol. Zentralbl.* **46**: 697-702. 1926.
132. STURTEVANT, A. H. A further study of the so-called mutations at the Bar locus of *Drosophila*. *Genetics* **13**: 401-409. 1928.
133. STURTEVANT, A. H. Known and probable inverted sections of the autosomes of *Drosophila melanogaster*. *Carnegie Instn. Washington Publ.* **421**: 1-27. 1931.
134. STURTEVANT, A. H., and TH. DOBZHANSKY. Reciprocal translocations in *Drosophila* and their bearing on *Oenothera* cytology and genetics. *Proc. Nation. Acad. Sci.* **16**: 533-536. 1930.
135. TIMOFÉEFF-RESSOVSKY, N. W. Does X-ray treatment produce a genetic after effect? *Jour. Hered.* **22**: 221-223. 1931.
136. VAN ATTA, E. W. Dominant eye-colors in *Drosophila*. *Amer. Nat.* **66**: 93-95. 1932.
137. VAN ATTA, E. W. Genetic and cytological studies on X-radiation induced dominant eye colors of *Drosophila*. *Genetics* **17**: 637-659. 1932.
138. WEINSTEIN, A. The production of mutations and rearrangements of genes by X-rays. *Science* **67**: 376-377. 1928.

Manuscript received by the editor November, 1934.

XXXIX

RADIATION AND THE STUDY OF MUTATION IN ANIMALS

JACK SCHULTZ

*Carnegie Institution of Washington, William G. Kerckhoff Laboratories
of the Biological Sciences, California Institute of Technology, Pasadena,
California*

Introduction. The discovery of the effect. The quantitative study of mutation. The characteristics of the mutation process: The diversity of mutation rates at different loci—The stability of different members of allelomorphic series—The localized occurrence of the mutation process—Chromosome breakage and the production of mutation—The “group effect,” the association of mutations with each other. The studies of general mutation rate: The relations between lethal and viable mutations—The variability of lethal mutation rate—Mutation rate in different tissues. The mode of action of radiation: General considerations—The relation between intensity and mutational effect—The relative effectiveness of different wave-lengths—The time factor, secondary reactions—Induced changes of susceptibility to irradiation—The question of direct effects. The causes of “spontaneous” mutation. The nature of the mutation process. References.

INTRODUCTION

The chief interest in the experimental production of mutations lies in the possibility of studying the nature of the mutation process and, by extension, of the gene itself. Of the many environmental agents tested, by far the most effective turns out to be short-wave radiation. Hence at the outset a double problem is presented. The effects of short-wave radiation on biochemical systems are comparatively little understood; accordingly there exists no extensive basis from which inferences as to the behavior of more complex systems may be drawn. From the opposite point of view, the effects of short-wave radiation in the production of mutations are apt to be instructive. Genes are at present the elementary biological units; a knowledge of their properties and behavior must necessarily have repercussions on many other fields of biology. For example, it is not difficult to see in the grosser effects of radiation on cell division the results of primary effects on the genes or chromosomes.

The first conclusive evidence for the production of mutations in animals by X-rays was presented by Muller (104) in 1927. In the relatively short time since then a large body of data has been accumulated and the field clearly outlined. Two general questions have been raised, and it is with the attempts to define and answer them that this review is concerned. The first involves solely the biology of the mutation process: what are its characteristics, now at last to be seen in semiquantitative

form? The second concerns its radiochemistry: how does short-wave radiation produce mutations? It may be remarked immediately that the significant advances to date have been made in the first field, an occurrence by no means surprising.

The change in outlook brought about by the introduction of X-rays into the study of mutation deserves some comment. It does not so much involve fundamental concepts; those already adumbrated in the studies of spontaneous mutation have proved surprisingly adequate. Now, however, with the help of short-wave radiation, experiments can be carried out that formerly would have been considered impossible.

THE DISCOVERY OF THE EFFECT

The history of the experiments on the genetic effects of radiation has an interest of its own. In the days following the rediscovery of mendelism, there were frequent attempts to induce mutations experimentally, just as the control of sex was sought by various environmental agents. It was evident at the time, from the cytological studies of the effects of X-rays and radium on tissues, that heritable variations might be produced. Attempts were not lacking to put this idea to the test.

Among the earliest mutations found in *Drosophila* (Morgan, 89) were some that appeared in progenies from radium treated individuals. Later Loeb and Bancroft (85) claimed to have obtained positive results which were shown by Morgan (91) to be unconvincing. Repetitions of such experiments by Morgan (Morgan, Bridges, and Sturtevant, 93) gave negative results, and Mavor (86, page 362) in his experiments on non-disjunction and crossing-over changes induced by X-rays, found no evidence of the production of mutations. Later, Muller and Dippel (118) reported incidentally an unsuccessful experiment designed to detect losses of small fragments of chromosome.

The results on other organisms were no more convincing. Little and Bagg (84) described experiments with mice in which they obtained from 12 treated individuals two mutations, one of which appeared in the controls. Subsequent attempts (Bagg, MacDowell, and Lord, 8; Snyder, 163) at repetition yielded negative results. The experiments of Dobrovolskaia-Zavadskaia (24, 25) are likewise not clear, since they involved one mutation probably present in the treated animal, and one other, in a progeny of some 3000 mice.

In the meantime Muller and Altenburg (114, 115), and especially Muller (97 to 103, 107, 108) had carried out an extended study of spontaneous mutation in *Drosophila melanogaster*. As a result of his studies, Muller developed a technique for the quantitative study of mutation. Using this technique, and the information on X-ray dosage available as a result of the previous failures, he repeated the attempt with, at last, great success. Once the proper experiment was performed, effects of such an

order were obtained as to be obvious even without special techniques. But the result was not attained before the construction of machinery for its measurement.

Following Muller's work, which was, interestingly enough, done at the same time as the independent work of Stadler on plants (164, 165), a host of confirmations appeared. Similar results have been obtained in all forms on which adequate experiments have been performed, and there is now every reason to believe that in principle the effect is a general one for all organisms.

THE QUANTITATIVE STUDY OF MUTATION

As has already been pointed out, an essential factor in the final success of Muller's X-ray experiments was the development of a technique for the study of mutation. The technique is in principle applicable to any organism; the details will, of course, vary with the form studied.

Ideally, for the quantitative study of mutations *en masse*, it would be desirable to detect all types of variants. This would include the lethal effects, the ordinary visible mutants, and the very slight types. Of these, the last present the greatest difficulty for measurement with any accuracy; there are at present no data available which permit even an estimate of their frequency, which may be higher than that of any other type. For the "visible" mutations, it is equally clear that criteria may differ from experiment to experiment, and notoriously from observer to observer. The frequency of occurrence of visible mutation might be determined with accuracy in an organism in which all the possible types of variation were known, and they could be distinguished from developmental accidents due to nongenetic influences. Even in *Drosophila melanogaster*, however, genetically the best studied of all animals, it is not possible to do this yet.

It is, however, possible to obtain accurate data if a specific mutant character, sharply distinguishable from the norm, is selected, and the frequency of its appearance measured. This is particularly easy for diploid organisms in the case of sex-linked mutations; the offspring belonging to the heterozygous sex display any new mutant which has occurred in the germ cells of the parent of the homozygous sex. In the case of organisms haploid in one sex, a new mutant in any chromosome is similarly detectable at its occurrence.

Lethal mutations, however, provide the most feasible approach to an objective criterion. Accordingly they were extensively used by Muller in his studies on mutation in *Drosophila melanogaster*. Essentially, the methods which he developed are based on the usual procedure for locating a lethal mutation (Morgan, 90). A character linked to a lethal appears in numbers proportional to the crossing over between the two genes. If, then, it is desired to test a group of chromosomes for lethals, crosses to a

stock with convenient marking genes afford the method. By the proper further crosses, it is then possible to ascertain the presence and locus of the lethal.

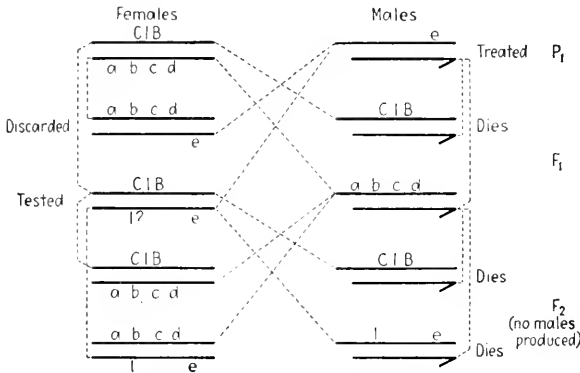

FIG. 1.—The *Cl B* technique for the measurement of lethal mutation rate in the X-chromosome of *Drosophila melanogaster*. This method is especially adapted for the detection of the effects of environmental agents on the male, since the tested X-chromosome is paternal. The lethal in the *Cl B* chromosome kills all males which carry it; the other X-chromosomes are generally distinguished by the use of marking genes, here denoted by the letters *a, b, c, d, e*.

This procedure has certain drawbacks. Counts must be sufficient to make the departure from the normal ratio significant. The viability of the marking genes must be adequate to avoid errors resulting from fluctuations due to the marking genes themselves. It was therefore advisable, and possible for Muller in *Drosophila*, to utilize refinements of technique which made the departures from a normal ratio more striking.

In *Drosophila*, and wherever the male is the heterozygous sex, a new sex-linked lethal reveals its presence by a ratio of two females to one male. The use of sex-linked marking genes provides a further check; the surviving males must bear a special relation to the marking genes, dependent on the locus of the lethal. Now if by some means, crossing over is suppressed between the chromosomes in question, only one type of male should appear. There are in *Drosophila* at present a number of stocks which make such tests possible. The first, and the most widely used, is Muller's *Cl B* stock described in detail in his 1928 paper (107), which contains a general discussion of the technique of measuring mutation rate.

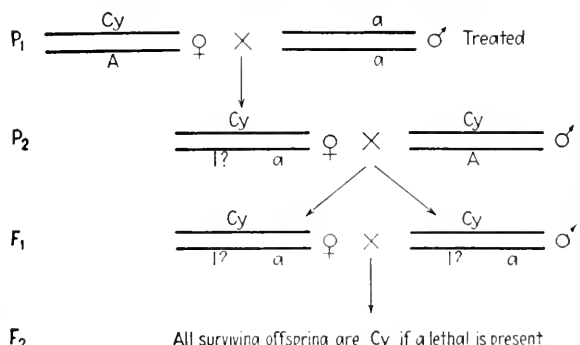

FIG. 2.—An experiment for the detection of lethals in the second chromosome of *Drosophila melanogaster*. The *Cy* chromosome eliminates the cross-overs in the female, and usually the homozygote does not survive. Either males or females may be treated, according to this technique; the diagram illustrates an experiment in which males are treated. It should be noted that, in this experiment, use is made of two dominant marking genes (*Cy* and *A*, which may be any one of a number of different dominants).

In this method, the presence of a new lethal is detected by a progeny consisting entirely of females (Fig. 1).

Autosomal lethals present a somewhat more difficult problem, although the difference is one of detail (Fig. 2). They allow a further elaboration of technique, which is not possible with sex-linked lethals. Since both sexes may carry an autosomal lethal, it is possible by appropriate crosses to carry, in "balanced" stocks, chromosomes which are allowed, generation after generation, to accumulate lethals. At the end of a stated period tests are made, and the occurrence of new lethals determined. This method presents in acute form the difficulty met with in all lethal mutation work that frequently two lethals which are closely linked may be mistaken for one.

The lethals so far dealt with are the recessive lethals. There is a class of dominant lethals, whose presence in single dose causes the death of the zygote. They are detected by departures from expected ratios in certain matings, and while they are probably largely due to chromosomal aberrations, are here mentioned because of their high frequency of detection in certain special cases (43, 54, 58, 105, 148, 167).

It is readily understandable that these techniques used in *Drosophila* do not, in principle, depend on special attributes of the species. Their generality is a function of the chromosomal mechanism on which they are based. It may be anticipated that mutation studies on any animal must be aided by a thorough study of the methods developed by Muller (see especially 107). Indeed, this has already been indicated by the studies of Snell (162) on mice and of Astauroff (6) on the silkworm.

Aside from technique, there is a question of definition, which must be considered here. It is this: the criteria which distinguish the mutation of genes from chromosome abnormalities are far from sharply defined. Chromosomal aberrations of various types have long been known (Bridges, 9; see also Mohr, 88) to produce character changes which might have been attributed to gene mutations. As Stadler (166) has pointed out, gene mutations form a residue, which includes those cases where no gross chromosomal abnormality can be demonstrated. This purely negative definition, while it has raised many theoretical difficulties, suffices in practice; that is to say, in planning experiments. Meanwhile, the recent work of Painter (128) on the chromosomes of the salivary glands of *Drosophila* raises hopes that presently some more definite criteria can be set up.

THE CHARACTERISTICS OF THE MUTATION PROCESS

THE DIVERSITY OF MUTATION RATES AT DIFFERENT LOCI

At the outset, experiments on mutation rate meet the difficult problems which populations present. Either a frequently occurring phenotype is selected—the lethal, for example—and the rate of its occurrence

measured; or a particular locus is chosen, and frequency of its change noted. In the first case, many different genes, with possibly different rates of mutation, contribute to the total percentage. On the other hand, if a particular locus is studied, the rate of mutation is so low even at high X-ray dosages, that experiments are exceedingly laborious. Moreover, there is no possible estimate of the frequency of undetected mutations. In spite of this, it is clear that in order to interpret the data from experiments where whole populations of genes are involved, the characteristics of these populations must be known analytically.

An exploratory survey can be provided by the enumeration of the recurrences of mutants at given loci. The frequency with which any gene appears in a group of mutations will be proportional to its own mutation frequency. It follows then that a comparison of the numbers of recurrences at different loci provides a measure of the relative mutabilities of these loci. This procedure is admittedly rough; it takes no regard of differences in viability, or detectability of different phenotypes; moreover the data are themselves collected in a haphazard manner, not for the specific purpose. But they do give a rough indication of what is to be expected.

Such a tabulation was provided for spontaneous mutations by Morgan, Bridges, and Sturtevant (93). For the radiation experiments, a comparable table can be constructed by using only the sex-linked mutants arising in experiments where all these would have been observed and recorded. The two groups are recorded in Table 1. For the autosomes, no X-ray data are as yet published.

It is clear that the recurrences of mutants at the different loci vary in the same manner in both groups, generally speaking. Two conclu-

TABLE 1.—RECURRENCES IN SPONTANEOUS AND INDUCED MUTATIONS IN THE X-CHROMOSOME OF *DROSOPHILA MELANOGASTER*

Locus	Spontaneous	Induced	Locus	Spontaneous	Induced
Yellow.....	15	6	Lozenge.....	10	2
Seute.....	4	9	Ascutex.....	1	2
White.....	25	17	Vermilion.....	15	4
Facet.....	1	2	Miniature.....	7	13
Echinus.....	1	3	Furrowed.....	2	2
Ruby.....	6	2	Garnet.....	5	1
Crossveinless.....	2	1	Rudimentary.....	15	8
Cut.....	16	1	Forked.....	12	17
Singed.....	5	3	Fused.....	2	3
Tan.....	3	2			

The data for the spontaneous mutations are from Morgan, Bridges, Sturtevant (93); the induced mutations are taken from the papers of Gowen and Gay (52), Hanson and Winkelman (71), Gruneberg (55), Dubinin (38), Serebrovsky and Dubinin (152), and unpublished data of the writer. These are cases in which all viable sex-linked mutations could be detected, and were reported.

sions are indicated: the characteristic frequency of mutation at a given locus is a function of that locus; and the sample of mutants from the X-ray experiments is much like the spontaneous sample. There are, at several loci (yellow; vermilion; and particularly cut) suggestions that the relative frequencies do differ. More data are needed to determine this point, which is of considerable interest particularly in connection with Stadler's extensive studies (166) of mutation rates in maize.

TABLE 2.—FREQUENCY OF MUTATION AT DIFFERENT LOCI IN THE X-CHROMOSOME OF *DROSOPHILA MELANOGASTER*

Locus	Tested chromosomes	Number of mutations	X-ray treatment	Authority
<i>y</i>	11,620	1	Adult ♂♂, 1325 r units	Moore (96)
<i>oc</i>	11,620	2	Adult ♂♂, 1325 r units	Moore (96)
<i>w</i>	48,500	37	Adult ♂♂, 4800 r units	Timoféeff-Ressovsky (183)
<i>ec</i>	11,620	6	Adult ♂♂, 1325 r units	Moore (96)
<i>v</i>	11,620	2	Adult ♂♂, 1325 r units	Moore (96)
<i>m</i>	11,620	1	Adult ♂♂, 1325 r units	Moore (96)
<i>g</i>	11,620	2	Adult ♂♂, 1325 r units	Moore (96)
<i>f</i>	11,620	2	Adult ♂♂, 1325 r units	Moore (96)
<i>f</i>	32,000	6	Adult ♂♂, and larvae, 3500 r units	Patterson and Muller (141)
<i>f</i>	19,000	5	Adult ♂♂, 4800 r units	Timoféeff-Ressovsky (183)

Quantitative data of a sort (Table 2) have been provided for the loci white and forked, by the experiments of Patterson and Muller (141) and Timoféeff-Ressovsky (175, 179, 181 to 183). More recently, the data of Moore (96) for eight other loci have been presented by Johnston and Winchester (76). Different loci apparently have their own characteristic mutation rate (Table 2) measured in the same experiment. The differences are more striking than is apparent in the recurrence table. It should be remembered, however, that the values in this table come from the addition of many heterogeneous groups of data. Moreover, certain other experiments of Timoféeff-Ressovsky (179) throw some light on one source of the heterogeneity.

He has studied the rates of mutation of the normal allelomorphs of white in two different geographical races of *Drosophila melanogaster*, and found in a series of carefully controlled experiments (Table 3) that the mutation frequency for these allelomorphs, which he could otherwise not distinguish from each other, shows a distinct difference. In other words, differently mutable forms of the same gene may exist. The importance of these data for the present discussion is obvious. Not only do genes at different loci have characteristically different mutation rates, but even the same locus may vary.

TABLE 3.—COMPARISON OF THE MUTABILITY OF THE NORMAL ALLELOMORPHS OF WHITE (W^A AND W^R) IN TWO GEOGRAPHICAL RACES OF *DROSOPHILA MELANOGASTER*
 Adult ♂♂, treated with X-ray dosage of 4800 r (Timoféeff-Ressovsky, 1979)

	Number of X-rayed genes	Number of mutations			Total mutations	Per-centages $W-w$, of all mutations	$W-w^x$ among all mutations
		$W-w$	$W-w^x$	Total			
W^A with "American" modifiers.....	31,000	22	5	27	0.087	81	19
W^A with Russian modifiers.....	28,200	19	9	28	0.100	68	32
W^A total.....	59,200	41	14	55	0.093 ± 0.012	75 ± 5	25 ± 5
W^R with Russian modifiers.....	49,200	13	13	26	0.053	50	50
W^R with American modifiers.....	26,100	6	8	14	0.054	43	57
W^R total.....	75,300	19	21	40	0.053 ± 0.008	47 ± 7	53 ± 7

Total mutations $W^A - W^R = 0.040 \pm 0.013$.

Relative per cent w and w^x mutations = 28 ± 8.5 per cent.

Demerec (13 to 21, 23) has made extensive studies of a group of frequently mutable genes in *Drosophila virilis*, which may be relevant to this problem. These are a group of recessives which frequently revert to the normal allelomorph. They exist in different forms which are distinguished by differences in their rates of mutation in the different tissues. It is, however, as yet an open question whether or not these genes belong to a special category; and therefore the differences between the various forms cannot be compared safely with those found by Timoféeff-Ressovsky.

THE STABILITY OF DIFFERENT MEMBERS OF ALLELOMORPHIC SERIES

In the preceding section it has been shown that mutation rate varies from locus to locus, and even that the same gene may exist in different forms distinguishable only by their mutation rates. For a closer analysis of this variation, it is necessary to consider the data on mutation rates in the different members of a series of multiple allelomorphs. This has been provided largely by Timoféeff-Ressovsky (179, 182, 183) for the white locus in *Drosophila melanogaster*, where the series is one of the most extensive available.

One of the necessary prerequisites to such work is the demonstration that recurrences of the different members of an allelomorph series are

actually found. Timoféeff-Ressovsky has studied this problem (184), and came to the conclusion that he is indeed dealing with recurrences of the same mutations, as far as the present technique can establish this. Each member of the series presents a group of effects whose association is constant. It may be noted that Friesen (44) has reached somewhat different conclusions, and more recent studies of Bridges (unpublished) show an unsuspected variety in the array of white allelomorphs—some of which may, nevertheless, on occasion be indistinguishable each from the other. Yet, as a first approximation, Timoféeff-Ressovsky's conclusion may perhaps be adequate.

TABLE 4.—MUTATIONS IN DIFFERENT DIRECTIONS AT THE WHITE LOCUS IN *DROSOPHILA MELANOGASTER*
Treated adult males, circa 4800 r. (Timoféeff-Ressovsky, 183)

Mutations to from	<i>w</i>	<i>w^{bf}</i>	<i>w^e</i>	<i>w^a</i>	<i>w^b</i>	<i>w^z</i>	<i>W</i>	Number of treated gametes	Total percentage
<i>W</i>	25	1	3	1	2	5	..	48,500	0.0763
<i>w^{co}</i>	1	6,000	
<i>w^b</i>	3	..	1	12,000	0.0333
<i>w^c</i>	1	5,000	
<i>w^a</i>	2	..	1	11,000	0.0272
<i>w^e</i>	13	1	2	2	39,000	0.0462
<i>w^{bf}</i>	1	5,500	
<i>w^d</i>	1	7,000	
<i>w</i>	1	1	..	1	54,000	0.00555
Total....	47	2	6	1	4	7	2	188,000	

The mutation experiments are, as has been said, enormously laborious, although the technique is simple. The rates are small, and it is difficult to attach more than qualitative value to such low percentages. Nevertheless, Timoféeff-Ressovsky has demonstrated (Table 4) that any one member of the series may on occasion change into another (Fig. 3), albeit with different frequencies. A striking instance is afforded

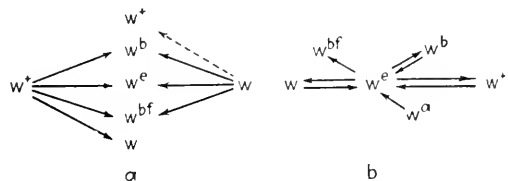

FIG. 3.—(a) Mutations from the wild type, and from white, to different intermediate allelomorphs; (b) mutations at the white locus to and from the intermediate allelomorph eosin (*w^e*). [After Timoféeff-Ressovsky (183).]

by the differences between the frequency of mutation to different allelomorphs of the two normal genes previously referred to (Table 3). The extreme reverse mutation, from white to wild type, has not been found; yet even here a two step reversion is possible: white to eosin, eosin to wild type. This is, as it were, a limiting case; for, in general,

mutations from darker to lighter allelomorphs are more frequent than the contrary. Moreover, of all mutations at the locus, that to white is the most frequent.

At other loci, no such elaborate studies have been carried out as yet. There are available data on the frequency of direct and reverse mutations for a number of loci, which are useful for orientation (Table 5). Originally carried out rather for the purpose of demonstrating that reverse mutations could occur (and hence that the action of radiation is not purely destructive), they nevertheless serve the same purpose as the experiments with the white allelomorphs. Patterson and Muller (141) and Timoféeff-Ressovsky (181, 182) have studied the locus of forked in some detail. More recently, Johnston and Winchester (76) have added to Timoféeff-Ressovsky's earlier data on miscellaneous loci a large body of experiments. From a comparison of their data with those of Moore on direct mutation they conclude that, in general, reverse mutations are much rarer than direct ones and that there seems to be no apparent relation between the two frequencies.

TABLE 5.—REVERSE MUTATIONS IN *DROSOPHILA MELANOGASTER*

Locus	Timoféeff-Ressovsky (175) 4800 r		Johnston and Winchester (76) 3975 r		
	Number of tested gametes	Number of reverse mutations	Locus	Number of tested gametes	Number of reverse mutations
Chromosome I					
<i>y</i>	6,354	..	<i>y</i>	69,923	1
<i>sc</i>	14,550	3	<i>sc</i>	101,042	3 (2?)
<i>w</i>	See Table 4	..	<i>w^a</i>	69,302	
<i>ec</i>	14,550	..	<i>ec</i>	57,323	
<i>cv</i>	6,354	1	<i>ct</i>	57,323	1
<i>ct</i>	9,788	..	<i>v</i>	61,119	1 (?)
<i>v</i>	16,142	1?	<i>m</i>	39,923	2
<i>g²</i>	9,788	..	<i>g</i>	57,323	4 (?)
<i>f</i>	29,000	7	<i>f</i>	130,421	11 (4?)
Chromosome III	<i>car</i>	69,302	1 (?)
<i>ru</i>	13,814	Patterson and Muller (141) forked locus	
<i>h</i>	13,814	1	..		
<i>th</i>	5,681	..	Larvae	1500 ± r	
<i>st</i>	13,814	..	Adult ♂♂	1500 ± r	
<i>p^b</i>	8,133	2		21,290	6
<i>cu</i>	5,681			11,298	2
<i>so</i>	8,133				
<i>sr</i>	5,681				
<i>cs</i>	13,814				
<i>ca</i>	5,681				

As has just been pointed out, the data involve such small numbers of mutations even in very large experiments that it is difficult to use them quantitatively. Especially are they complicated by such possibilities of variation as those which Timoféeff-Ressovsky has demonstrated (page 1217) for the white locus. If, in spite of this, the frequency of mutation to a given type is plotted against the frequency of mutation from it, a surprisingly regular inverse function results (Fig. 4). It is difficult to trust such a curve too far; yet taken at its face value it indicates that the frequency with which any gene is obtained as a mutation is a function of its own stability. Thus most of the mutations at the white locus are mutations to white, itself the most stable member of the series. Such a relation might result from a number of simple chemical mechanisms; it is implied in the well-known Galton polygon, so frequently used as an analogy for mutations (Morgan, Bridges, and Sturtevant, 93; Patterson and Muller, 141). But much more data are necessary before elaboration of such ideas would be useful.

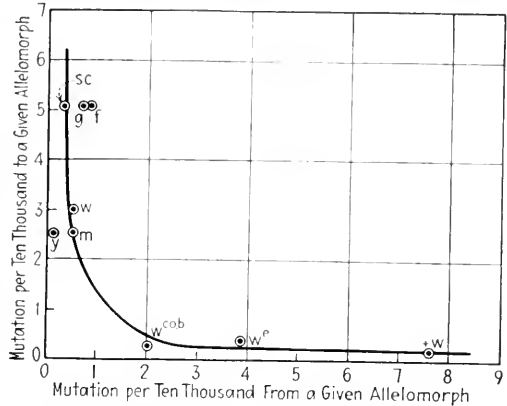

FIG. 4.—The relation between the frequency of mutation to a given allelomorph, and its own mutation rate to other allelomorphs. It should be noted that the probable errors of such low values are in themselves relatively large. Moreover, the data for the white locus (Table 4), from Timoféeff-Ressovsky (183); for the other loci (Table 5), from Johnston and Winchester (76), are in themselves subject to error which can not be properly evaluated. Different allelomorphs are not separated, and heterogeneous data are lumped. Each point on the curve represents the frequency of mutation to a given gene in all the available data. A full discussion of the questions involved cannot be given here; but the discovery of the possibility of a general rule for such occurrences seems interesting enough for presentation.

THE LOCALIZED OCCURRENCE OF THE MUTATION PROCESS

In the foregoing sections it has been made evident that the probability that a mutation will occur is a property of the particular gene concerned. This being so, it becomes of interest to note whether, when two members of an allelomorphic pair are present, both mutate simultaneously, or only one of the two changes. The question at issue may be phrased differently: is the mutation process a local occurrence, or is it the response of a given gene to a general change in environment? If the latter were true, both members of a pair should change at the same time; on the former hypothesis, either one or both might change.

It has long been known, from the work on frequently mutating genes in plants, that mutation occurred in only one member of a pair, since the recessive mutants were only detected in the heterozygotes. Muller (98) pointed out a similar possibility in *Drosophila melanogaster* from the fact that new mosaic mutants occurred only in the case of sex-linked recessives in the male, except for the cases of dominants. The reasoning was essentially that used in the plant work—the male is haploid for the X-chromosome, hence any recessive mutant shows immediately. In the female, and in both sexes for the autosomes, two members of each allelomorph pair are present, and only if mutation occurred simultaneously in both could the mosaic be detected. In the X-ray work on *Drosophila* it has been possible to test this experimentally by studies of induced somatic mutations obtained by the irradiation of larvae. Patterson (131, 133) has shown that somatic mutations to white are detected only in the male, or in heterozygotes where white is semidominant (Table 6).

TABLE 6.—SOMATIC MUTATION TO WHITE IN *DROSOPHILA MELANOGASTER*
Only one of the two allelomorphs present in the female mutates, hence no mosaics are found in the females. They are, however, found in the males. (Patterson, 133)

A. Wild-type larvae irradiated by X-rays at various stages of development (up to 84 hr.)

Group	Total ♀ ♀	Number of mosaics	Total ♂ ♂	Number of mosaics for white
Treated.....	395	..	424	9
Controls.....	440	..	449	

B. Eosin and apricot larvae, treated as above. Here the mutation to white in one of the allelomorphs of the female is detectable in the heterozygote as a "light area"

Group	Total	Light areas	White areas
Apricot ♀ ♀.....	271	2	
Apricot ♂ ♂.....	230	..	2
Eosin ♀ ♀.....	1020	19	
Eosin ♂ ♂.....	925	..	9

A more direct method of test is afforded by the study of individuals which have received both members of a pair of chromosomes from one parent. This was done by Bridges [Morgan, Bridges, and Sturtevant (93)] in his work on stocks which gave high nondisjunction of the X-chromosomes. Two cases were found in which a mutation had occurred in one chromosome, but not in its partner. Thus only one of the genes of a pair had mutated, and not the other.

The same technique has been used by Patterson and Muller (141) in the study of X-ray-induced mutations. They irradiated females, a large proportion of whose daughters would receive both X-chromosomes from their mother. Among 104 daughters so tested, two lethals were found, and two reverse mutations at the scute locus. In all four cases, the mutation had occurred in only one member of the allelomorphic pair.

There is another body of data which leads to the same conclusion. When adult males of *Drosophila* are irradiated, which implies the treatment of mature spermatozoa, mosaic mutants appear among the progeny. Muller (105) has termed these "fractional" mutations and has pointed out that they usually involve half of the fly. A fractional mutation must therefore involve the mutation of one of the daughter genes of a given chromosome, without the same mutation in the other—an even more striking example of the strict localization of the mutation process than those previously given. It should be noted that many of the cases of "somatic" mutation found in untreated material probably belong to the same category as the fractionals in treated material, so that the phenomenon is common to both induced and spontaneous mutation. The possible interpretations of fractional mutation will be considered later with reference to Moore's (96) data and the possibility of an aftereffect of X-rays.

From these three lines of evidence, then, it is clear that the mutation process as we know it in *Drosophila* is the result of a local disturbance, and not a general change to which specific genes respond. Something happens in a given neighborhood, the result being, as we have seen in the previous sections, determined by the neighborhood.

CHROMOSOME BREAKAGE AND THE PRODUCTION OF MUTATIONS

In the preceding section it has been shown that the mutation process must be traced to a local disturbance and not to the response of a given gene to some general change in the cell. It is now worth while to examine the proposition from another angle: What are the effects on the production of mutation of other local changes in the chromosome? The simplest of these is chromosome breakage.

This occurs normally, of course, at every meiosis, in organisms where crossing over is found. Crossing over is not, however, followed by mutation ordinarily, nor is mutation known even to be associated with the ordinary crossing over (Sturtevant, 169). In the case of the frequent "mutations" of the gene *Bar* in *Drosophila melanogaster*, Sturtevant has shown (169, 170) that this, a special case, is concerned with unequal crossing over. Two aberrant types result, in the case of the homozygous *Bar* female: one which has no *Bar* genes; and one which is an extreme *Bar*, and contains two *Bar* genes in one chromosome. The juxtaposition of

the two allelomorphs in one chromosome, instead of their being in two separate chromosomes, produces a much stronger developmental effect. Sturtevant accordingly suggested the hypothesis that the position of genes relative to each other in the chromosome is a factor in determining their developmental effects. Were this so, breakages of chromosomes which change the normal constellations of genes should produce effects similar to mutations. Indeed, if the hypothesis is carried to its logical conclusion, it becomes very difficult to devise a criterion which would distinguish a true gene mutation from a position effect. The only available method at present lies in the analysis of what happens at the breakage points in chromosome rearrangements.

In the first place, it should be noted that of the relatively few "spontaneous" chromosome rearrangements, a majority show phenotypic changes located at the points of rearrangement. Bridges' (10) original Pale translocation in *Drosophila melanogaster* was detected by virtue of such an effect; similarly, with the "Blond" translocation of Burkart (11) and Burkart and Stern (11a); while Muller's *Cl B* inversion (107); the "Curly" complex of Ward (187); Sturtevant's (33) translocation II-III *E* afford further examples of rearrangements with phenotypic changes located at the points of rearrangement.

It is in the X-ray-induced rearrangements that the phenomenon becomes really striking. Muller and Altenburg (116, 117) and Dobzhansky (27, 28, 30) found that the majority of such rearrangements were lethal when homozygous, or else showed characteristic mutational changes. Oliver (125) made a similar observation in the X-chromosome regarding the correlation of lethal effects and chromosome rearrangements leading to a reduction of crossing over. More recently, Patterson, Stone, Bedichek, and Suche (142) have supplied extensive data on the relative frequency of lethal effects in the homozygotes of translocations.

TABLE 7.—TESTS OF TRANSLOCATIONS FOR VIABILITY IN HOMOZYGOUS CONDITION
(Patterson, Stone, Bedichek, and Suche, 142)

Types	Number tested for viability as homozygote	Number viable	Percentage viable	Number fertile	Percentage fertile	Undetermined fertility
T_A 1-2	57	30	52.6	21	91.3	7
T_A 1-3	71	30	42.2	27	90.0	
T_A 1-4	14	14	100	13	100	1
T_A 2-4	33	23	69.6	15	88.2	6
T_A 3-4	37	18	48.6	16	88.8	
T_A 2-3	120	19	15.8	19	100	

Expected percentage of viable and fertile 2 to 3 translocations: 17.6.

Their data are given in Table 7. It is possible to compute, as they have done, from the frequency of viable, fertile homozygotes in the translocation types 1-2, 2-4 and 1-3, 3-4, the expected frequency of the 2-3 type. This can be done because there are no lethals in the 1-4 type, and it may hence be inferred that the chance of picking up a lethal effect in chromosome IV is negligible. In chromosome I no lethals are recovered in their experiments, therefore any lethal effects must be due to chromosomes II or III. The computed and observed percentages for the 2-3 type are in close accord. From this, and from the rough determinations of the locus of the point of break available, they conclude that there is "no positive correlation between the region of breakage and the lethals induced at the time of breakage." This depends for its validity chiefly on the determination of locus of break, a determination difficult, if not impossible, to make by genetic methods with the accuracy required. The finer analysis possible as a result of Painter's (128) explorations of the size and differentiation of the chromosome of the *Drosophila* salivary gland is needed for this purpose. The other point, the agreement between calculated and observed values of viable homozygotes, indicates simply that the occurrence of a lethal effect is a function of the chromosome in which that effect occurs and need not depend on the other chromosome involved in the translocation. The question is a complicated one which is difficult to settle without more detailed data than are at present available, except in a few cases. These concern the study of mutations localized around the breakage points of chromosome rearrangements.

There are two ways in which such experiments may be conducted. Either the tests are so arranged that a particular mutant effect is detected, and examined for the occurrence of a break; or a particular type of rearrangement is selected, and then examined for the occurrence of the "mutation." Both permit the determination of whether a given break is associated with a given mutant effect. The latter type of experiment tests in addition the possibility that an effect occurs only in association with a break, but that not all breaks at a locus produce the effect. Four loci in all have been studied in either one or the other of these ways: Bar (X-chromosome, 58.0), brown (II, 104 to 106), bobbed (X, 66) and cubitus interruptus (IV, near spindle attachment).

At the bar locus, the first data of this kind were supplied by Dobzhansky's study (31) of a mutant which he called baroid. This represented a mutation from wild type to baroid; it was found to be associated with a translocation whose locus in the X was at Bar, and indeed by all available tests turned out to be a Bar allelomorph. According to Sturtevant (171) no effective normal allelomorph of Bar can be detected. Dobzhansky, making use of the demonstrated position effect at the Bar locus, suggested that the appearance of the baroid mutation was an effect of the change of neighbors brought about by the rearrangement of

genes. It may be remarked (*see* Stadler, 166) that this is of particular interest in connection with Hanson's (59) reversions at the Bar locus.

Similarly for the brown locus, a series of dominant brown allelomorphs—all of them producing variegated eye colors—were detected in progenies from X-ray experiments. These were then (46, 47, 48, 111, 149, 186, 188) found to be associated with chromosome rearrangements which in all cases had one of the points of breakage near the brown locus. Furthermore, in two of the cases tests were made (Schultz and Dobzhansky, 149) of the genes lying in the region of the other break, and mutations were found to have occurred there also. It was also possible to demonstrate that no simple occurrence of gene deficiency could account for these results. This case, it should be noted, is complicated by the variegation which is associated with all these mutations and whose analysis is essential for the understanding of their nature.

In the case of bobbed and of cubitus interruptus, the rearrangements have been selected and then studied for mutations. Sivertzev-Dobzhansky and Dobzhansky (159) found that all of the five aberrations with breakages near the bobbed locus showed, under the proper circumstances, mutations to bobbed. Similar cases have also been reported by Sidorov (157), and by Stern (168*a*). Again there is an association between breakage in a given region, and mutation.

The most striking case of all, however, concerns the extensive series of translocations involving the fourth chromosome, tested by Dubinin and Sidorov (41). Out of 19 translocations, 10 exhibit an apparent mutation to cubitus interruptus, when heterozygous for this recessive. Dubinin and Sidorov further show that the translocations themselves do not manifest cubitus interruptus under conditions when they might be expected to, did they contain the gene mutation itself. The phenomenon is then a decrease in the dominance of the normal allelomorph of cubitus interruptus which is present in these 10 translocations. Also in certain of their translocations, mutations are found at both points concerned in the translocation. This behavior of cubitus interruptus may be compared with Dobzhansky and Sturtevant's (34) data on the decrease of dominance in a series of X-chromosome duplications.

All of the cases discussed agree in the correlation of specific mutational effects with breakages in specific regions. They do not, however, afford as yet a demonstration of position effect comparable to that given in the original case of Bar. In each case, specific objections may be raised which prevent complete conviction. In the case of baroid, mutation alone may account for the result; in the dominant eye colors, the variegation complicates the issue; bobbed may be concerned with the general problem of the inert region (Muller and Painter, 120; Dobzhansky, 32); and the cubitus interruptus case, the most extensively tested, may merely involve mutation to a different potency of wild-type allelomorph. Moreover, all

of these cases await the more accurate data on locus of breakage afforded by cytological study of the chromosomes of the salivary glands.

Despite these objections, it seems probable that the mutational effects actually are due to the change of neighboring genes resulting from translocation. The alternative hypotheses reduce to two: (a) presence of deficiency at the locus of break, owing to destruction of genic material at the time of break; or (b) mutation in a broad sense. The former hypothesis, as has been seen, is specifically eliminated in three of the previous cases. As a general proposition for lethal effects it is rendered unlikely by experiments of Schultz (Morgan, Bridges, and Schultz, 94) to test the association of deficiencies with translocations. Forty Minutes, which belong to a dominant phenotype probably due in most cases to deficiency, were found in an X-ray experiment. They were then tested for translocation; not one was found, although under similar circumstances a few might have been expected as a chance occurrence. Certainly there is no marked association between the production of deficiencies and of translocations.

The present data do not offer the possibility of completely excluding the mutation alternative. A position effect must, properly speaking, be due to an upset of the normal relation between a gene and its neighbors; when new neighbors are substituted for the old, the gene behaves differently and an apparent mutation results. However, it is possible that the mere separation is sufficient to bring about a change in the gene, owing to the disruption of intergenic bonds (Muller and Altenburg, 117; Sivertzev-Dobzhansky and Dobzhansky, 159). This, however, is not properly to be classed as a position effect; proof of specific mutual relations between neighboring genes is necessary first.

Certain data on the behavior of the dominant brown allelomorphs point in this direction (Schultz and Dobzhansky, 149). It may be surmised, however, that the study of the reversibility of such mutational effects may provide a real distinction; since the reverse rearrangement will also involve a break, there should be, unless a true position effect exists, no corresponding specific reversal of the mutational effect.

THE "GROUP EFFECT"—THE ASSOCIATION OF MUTATIONS WITH EACH OTHER

From the preceding section, it would appear that apparent mutational effects are associated to a high degree with chromosome breakages. Whatever the interpretation, the fact raises another question: To what degree are mutations associated with each other? Muller (113) has addressed himself to this problem in the following way, which resembles the methods used in the study of mutations at the breakage point of translocations: He selected mutations at the locus of *scute*, and then

tested for other mutations nearby. The detailed data are not as yet published; but it appears that perhaps more than one-quarter of the scute mutations found are lethal, or associated with a lethal. In a number of cases Muller was able to demonstrate that the lethal was at a different locus from scute. Similar data were previously available in a few scattered cases (Muller, 112; Patterson and Muller, 141). The chance expectation of such an association of two mutants is very low; the results suggest therefore that, although the mutation process is highly localized, it is nonspecific in the sense that more than one gene in a given neighborhood may be affected. Muller and Mott-Smith (Muller, 113) have examined and discarded the possibility that two hits by a single electron could account for the observed results. It follows that the phenomenon is a property of the biological system.

For distances farther apart, there appears to be no correlation, if the results of Gowen and Gay (52) on lethal mutations are to be accepted. Yet Muller (112) has found a case in which of all three mutations in a given experiment, two at widely separated loci occurred in a single individual. Moreover, it is to be remarked that in these experiments one chromosome only was followed; such correlations may extend to the other chromosomes as well.

The data of Patterson and Suche (143) show that in 20 cases, where crossing over was induced in the male by X-rays, six lethals were found, of which two were separable from the locus of crossing over. Shapiro and Neuhaus (156) have obtained with a higher X-ray dosage 7.8 per cent of lethals in the second chromosome. The result indicates a possible correlation between the occurrence of crossing over in the male and the production of lethal mutations. Contrariwise, these lethals showed no tendency to accumulate close to the breakage points (or points of crossing over), a result to be expected on the position-effect hypothesis. However, the relation of the crossing-over process to the process of translocation is still too unsettled to permit this to be used as evidence.

The interpretation of the group effect is obviously bound up with the interpretation of the mutational effects at breaks in chromosomes. It is, as Muller has pointed out, possible to regard the cases which have been discussed in connection with position effect as instances of the grouping of mutational effects. This depends on an assumption which can now, by the analysis of the chromosomes of the salivary glands, be verified—that the point of mutation and break are not the same, but close together. On the other hand the group effect itself is based for its demonstration on data which involve lethals—possible deficiencies, and therefore capable themselves of producing changes resulting in position effects. The chief question then, is whether there are two phenomena represented in these data, or one.

THE STUDIES OF GENERAL MUTATION RATE

THE RELATION BETWEEN LETHAL AND VIABLE MUTATIONS

In the preceding sections it has been shown that the population of genes varies in the frequency with which its members mutate, that this mutation is a highly localized process, and that at any given locus it occurs in directions whose frequency may be related to the stability of the resulting genes. Moreover, in any group of mutations occurring under conditions where chromosome breakage is frequent, many will be associated with the points of breakage; and the occurrence of one mutation in a gamete probably increases the chance that another will be present. These are the properties which must be expected to influence the composition of any collection of mutations to a given phenotype. It is with such collections of mutations that the greater part of the mutation experiments are concerned, particularly those having to do with the mode of action of radiation.

The lethal-mutation experiments, the technique of whose performance has been described, make it possible to obtain measurable percentages of mutation, even "spontaneously." They justify therefore, only as a matter of convenience, the difficulty of interpretation introduced by lumping so heterogeneous a group of genes as are necessarily collected in the lethal mutations. It has long been suspected, moreover, (Morgan, Bridges, and Sturtevant, 93) that these are in the main due to losses of small sections of chromosomes. The question is one which needs investigation in the chromosome of the salivary glands, where alone it should be possible to decide whether most lethals are actually deficiencies. It is obvious, and will be considered in more detail later, that such a

TABLE 8.—COMPARISON OF FREQUENCY OF LETHAL AND VIABLE MUTATIONS IN THE SEX CHROMOSOME OF *DROSOPHILA MELANOGASTER*

Authority	Number lethals	Number viables	Ratio lethal: viable
Muller (105).....	89	39	2.23*
	138	16	8.62
Timoféeff-Ressovsky (178).....	89	8	10.12
	57	3	19.00
	82	4	20.5
Patterson (138).....	112	16	7.00
Gowen and Gay (52).....	320	44	7.27
Timoféeff-Ressovsky (185).....	302	31	9.74

* This low ratio may be due to the inclusion of autosomal dominants in the viable mutations.

demonstration would materially change the interpretation of certain experiments. Patterson (138) has indeed shown in tests of a series of chosen genes that on the average seven-eighths of the apparent mutations at a locus probably are deficiencies and also are recessive lethals.

In Table 8, the data of a number of investigators have been brought together, and a comparison is available of the relative frequencies of lethal and viable mutations. It may be remarked that the agreement between the different investigators is surprisingly good. It was then necessary to show that under given conditions the same picture would present itself when lethal mutations were studied, as was found with the viable mutations. Muller (107) accordingly in his studies of spontaneous

lethal mutation carried out tests of the lethals, designed to determine whether their distribution on the chromosome was like that of the viable mutations. This he also did for the lethals of his X-ray experiment (105) and similar tests have been carried out by Harris (72), Oliver (125), and Gowen and Gay (52). If against the genetic map as an abscissa the frequency of mutation per unit is plotted, a marked clustering of mutations in certain regions is detected. This is due to a discrepancy between the cross-over map and the cytological map (28, 29, 32, 120) which is dependent on regional differences in the frequency of crossing over. Figure 5 shows

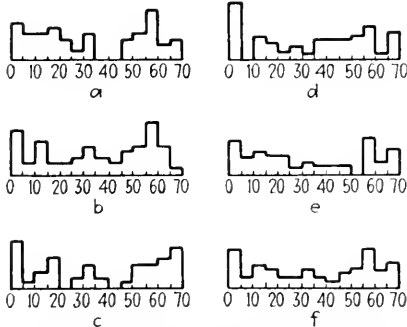

FIG. 5.—The distribution of lethal mutations in the X-chromosome of *Drosophila melanogaster*. The chromosome, whose genetic map is the abscissa, is divided into regions five units in length. The ordinates are numbers of lethals: (a) 47 lethals, dosage 385 r; (b) 57 lethals, dosage 770 r; (c) 46 lethals, dosage 1540 r; (d) 46 lethals, dosage 3080 r; (e) 37 lethals, dosage 6160 r; (f) 233 lethals, total. (After Oliver, 125.)

the results of Oliver's (125) experiments. It is clear that a clustering exists, such as is found in the visible mutations for the X. This shows then that, in a lethal-mutation experiment, the same population of genes furnishes the mutations as in an experiment with viable mutations. It should be clearly understood, however, that it does not necessarily follow that the same genes, or type of mutation process, are involved in both cases. For the observed clustering probably depends merely on the differences in the numbers of genes between two points in different parts of the genetic map.

Whatever the relation between lethals and viable mutations, the bulk of the quantitative data available concerns the former. A discussion of the experimental attack on the nature of the mutation process is therefore to a large extent an account of experiments with the rate of lethal mutation.

THE VARIABILITY OF LETHAL-MUTATION RATE

As has been indicated, even the total rate of lethal mutation per chromosome, under usual conditions, is quite low, and hence has a high probable error. It is therefore of interest to compare the values for the X-chromosome, obtained by different experimenters, and so to have some notion of the variability of the process with which we are dealing, under ordinary conditions. In Table 9, the control values provided by a number of investigators have been put together. It is difficult with such low percentages to make any satisfactory estimate of variability, although certain values appear definitely low and others high. What is clear is that all are of the same order of magnitude.

TABLE 9.—VARIATION IN SPONTANEOUS LETHAL-MUTATION RATE IN THE X-CHROMOSOME OF *DROSOPHILA MELANOGASTER*
A summary of the control data in the *Cl B* experiments

Authority	Number of chromo- somes tested	Number of lethals	Percentage of lethals
Muller (107).....	3,935	4	0.102
Muller (105).....	198		
Harris (72).....	986	2	0.202
Hanson and Heys (60).....	423		
	1,308	1	0.076
Muller (112).....	984	2	0.202
	1,013	7	0.690
	479	1	0.204
Timoféeff-Ressovsky (178).....	793	1	0.126
	984		
Babcock and Collins (7).....	3,362	9	0.261
	986	1	0.101
Patterson (134).....	453	1	0.221
	952	2	0.210
Timoféeff-Ressovsky (185).....	1,827	2	0.109
	3,058	4	0.130
Oliver (125).....	4,033	10	0.248
Efroimson (43).....	371	1	0.269
Total.....	26,145	48	0.180

There is no such extensive series of data for any other chromosomes. Muller (107) in studies of the second chromosome of *Drosophila melanogaster*, found in one experiment involving 4038 tested chromosomes, a lethal percentage of 0.58; in another, with 6462 chromosomes, the percentage of lethals was 0.48. Their average (0.53), it will be noted, stands to the average percentage of 0.18 for the X-chromosome, given in Table 9, in the ratio of 2.9. More recently, in an X-ray experiment, Shapiro and Neuhaus (Table 12) have found, in the mature spermatozoa, at a dosage of 2134 r-units, a value of 9.1 per cent of lethals for this chromosome. The value for the X-chromosome, at a comparable dosage, would be about 5.9 per cent (see Fig. 6)—a ratio of 1.5. Neither of these ratios departs significantly from the ratios of the genetic maps, or the ratios of the lengths of these chromosomes in the salivary glands. Comparison of such data from different experiments is, however, dangerous. Although the conclusion is plausible that the average mutation rate in the two chromosomes is the same, further data are necessary to establish it.

In certain earlier experiments, Muller and Altenburg (114) found much higher rates in the X-chromosome—as high as 1.0 per cent. The explanation is not at all obvious, and Muller in a later paper (107) gives some additional evidence of similar variability. There is no evidence in other forms than *Drosophila* that bears on the question, nor is there sufficient evidence on any other than the X-chromosome even in this form. The only possible comparisons involve X-ray-induced mutations. Certain data adduced by Timoféeff-Ressovsky (172) indicate a somewhat low rate of sex-linked lethal mutation in *Drosophila funebris*, 7.4 per cent as compared with 12.8 per cent for a comparable dosage (3600 r) in *Drosophila melanogaster*. Other species of *Drosophila* have not been sufficiently studied. It would seem that in *Habrobracon* mutation to lethals is quite frequent, although viables are rare (12, 42, 189, 190, 191, 192). Snell (160, 161, 162) has studied the genetic effects of X-rays (600 r) on male mice, and found no lethals in 208 gametes tested. In the silkworm, Astauroff (6) found, after treatment with the gamma rays of radium, six apparent lethals in 181 cultures. From the above discussion it is evident that the problem of variability within a species is a sufficiently difficult one to make its descriptive study unattractive. There are, however, definite conclusions concerning mutability in different tissues, at different stages of maturation of the germ cells.

MUTATION RATE IN DIFFERENT TISSUES

Two groups of data comprise the information available at present: one, the comparison of rate of mutation in germ cells irradiated at different stages of maturity, or in the two sexes; the other, the study of somatic mutation. In either case a comparison is attempted of the response of

cells of different types to a given dosage of radiation. These experiments have all been done with *Drosophila melanogaster*; only exploratory data are available in *Habrobracon* (Whiting and Bostian, 189).

If a male *Drosophila* is irradiated and mated at intervals to a succession of virgin females, the progeny from the different broods will have

TABLE 10.—AGE OF GERM CELLS AND LETHAL-MUTATION RATE IN THE X-CHROMOSOME OF *DROSOPHILA MELANOGASTER*

Data of Harris (72): X-ray treatment of adult ♂♂; tungsten target, 50 kv. 10 ma., 13 cm., 30 min.

Age of germ cells in days after X-raying	Number of tested gametes	Percentage of lethals
1-4	1206	8.6
4-8	886	9.7
8-12	875	7.3
12-16	960	1.7
16-20	823	0.6
20-24	740	0.8

Data of Hanson and Heys (62): A. ♂♂ treated with 150 mg. Ra for 9 hr.; B. ♂♂ treated with X-rays "circa $\frac{1}{2}$ ra dose"

Age of germ cells in days after X-raying	A Percentage of lethals	B	
		Number of tested chromosomes	Percentage of lethals
1-7	13.00	504	6.5
7-14	14.20	605	6.4
14-21	1.01	614	2.9
21-28	4.30	470	2.1
28-35	0.00		

Data of Timoféeff-Ressovsky (178): males irradiated once with 2500 r; mated to virgin ♀♀ every 5 days

Age of germ cells in days after X-raying	Number of chromosomes tested	Percentage of lethals
1-5	417	6.9
5-10	491	8.3
10-15	481	7.3
15-20	478	4.0
20-25	411	3.1
25-30	389	1.8
Control	984	

come from sperm treated at different stages of spermatogenesis, making a comparison immediately possible. The proper tests will then show any variation of effect at the different stages. Experiments of this sort have been carried out by Harris (72), Hanson and Heys (62), and Timoféeff-Ressovsky (178) for the *X*-chromosome, and by Sidorov (158) and Shapiro and Neuhaus (156) for the second chromosome. The experiments on the *X*-chromosome agree in showing a striking decrease in the percentage of lethal mutations, occurring between the twelfth and sixteenth days after raying (Table 10). But in the second chromosome, the decrease is much slighter—scarcely statistically significant (Tables 11, 12). These differences, both between early and late broods, and between the behavior of the *X*- and second chromosomes, are fully explained by the assumption (Harris, Timoféeff-Ressovsky) that lethal effects induced in the immature germ cells are eliminated before the formation of the mature gametes.

TABLE 11.—LETHALS IN CHROMOSOME II AND AGE OF GERM CELLS IN TREATED ♂♂ OF *DROSOPHILA MELANOGASTER*
Data of Sidorov (158): 50 kv., 5 ma.; 1 mm. Al filter; distance 17 cm.; exposure 2 hr.

Age of germ cells after treatment	Number of tested gametes	Number of lethals	Percentage of lethals
1-7	138	33	23.9
7-14	80	21	26.3
14-21	62	14	22.6
21-28	48	11	22.9

TABLE 12.—COMPARISON OF FREQUENCY OF LETHAL MUTATION IN GERM CELLS OF DIFFERENT AGES IN CHROMOSOME II OF *DROSOPHILA MELANOGASTER*
Shapiro and Neuhaus (156): X-ray treatment; 120 kv., 5 ma.; 1 mm. Al filter; 17 cm. from anticathode; 11-min. exposure; 2134 r

Age of germ cells after treatment	Treated ♀♀			Treated ♂♂		
	Number of tested gametes	Number of lethals	Percentage of lethals	Number of tested gametes	Number of lethals	Percentage of lethals
1-12	204	15	7.35 ± 1.23	219	20	9.13 ± 1.32
12-24	259	15	5.79 ± 0.98	231	18	7.79 ± 1.19

Timoféeff-Ressovsky (178) in particular has put this to the test. Lethal effects of the type postulated, when they occur in the mature sperm, will have no effect (Muller and Settles, 122); but they will be

likely to kill the zygote in the egg stage. Hence if the mortality of progenies from the different types of treated gametes is compared, a greater egg mortality should be found where mature sperm were treated, than where immature germ cells (either from treatment in the larva, or from males two weeks after treatment) are concerned. This is indeed the case (Table 13) and is made particularly evident by the substantial identity between the larval mortalities in all three progenies.

TABLE 13.—MORTALITY OF EGGS AND LARVAE IN THE PROGENY OF ♂♂, WHOSE GERM CELLS WERE IRRADIATED AT DIFFERENT STAGES (Timoféeff-Ressovsky, 178)

Type of culture	Number of eggs laid	Number of larvae hatched	Percentage of eggs mortality	Number of flies emerged	Percentage of larval and pupal mortality	Percentage of eggs developing into adults
Adult ♂♂ irradiated: sperm 10–15 days after irradiation.....	1829	437	76.1	235	46.4	12.8
Adult ♂♂ irradiated: sperm 15–30 days after irradiation.....	2172	1463	32.6	918	37.3	42.2
♂♂ irradiated as larvae..	1763	1272	27.8	656	48.4	37.2
Control.....	4763	3738	14.5	3348	10.4	76.5

This should hold for the X, where in the treated male, only one representative is present; but in the autosomes, two of each type are present in the immature germ cell, and as has been shown earlier, only one of each of the allelomorphs in a cell mutates. In such a case, autosomal lethals should be at a lesser disadvantage. Thus, the slight decreases in the lethal percentage from immature germ cells, obtained by Sidorov (158) and by Shapiro and Neuhaus (156) in their work on the second chromosome support the view of elimination of lethals rather than a difference in the susceptibility to radiation. In the female, the picture is pretty much that of the immature germ cells of the male (Muller, 105, 112). Similar results have been obtained for *Drosophila pseudo-obscura* (Schultz, 148).

It seems that the lethals which are eliminated probably belong to the class of chromosome aberrations rather than gene mutations. Patterson and Muller (140) noted that the frequency of chromosome aberration is higher in adult males than in females treated with the same dosage (Table 14). Shapiro (155) and Shapiro and Neuhaus (156) have similarly shown that the frequency of translocations between the second and third chromosomes is greater in mature spermatozoa than in the

TABLE 14.—COMPARISON OF CHROMOSOME ABERRATIONS AND POINT MUTATIONS AFTER TREATMENT OF ADULT MALES AND FEMALES
 ♀ Data of Muller (Patterson and Muller, 141); ♂ Data of Oliver (125)

Sex treated	Number of tested chromosomes	"Point mutations"		Aber-rations	Percentage of	
		Lethal	Viable		"Point mutations"	Aber-rations
♀ "t4"	761	16	2	1?	2.3	
♂ "t4"	1144	46	..	7	4.0	.61

spermatocytes or spermatogonia. The differences are of an order of magnitude sufficient to account for the differences in the observed lethal-mutation rate.

Were this so, the proportion of viable mutations should be constant no matter what stage of development is treated. Earlier experiments of Muller (112) had indicated a higher proportion of viable mutations from mature spermatozoa (Table 15). However, the more extensive experiments of Timoféeff-Ressovsky (Table 16), of Hanson and Winkelman (Table 17), and particularly of Moore (Table 18), show only slight differences in the proportion of visible mutations obtained either in the two sexes or in the different age groups. It is conceivable that, as Muller has suggested, the difference is due to a difference in rate of division of mutant and germ cell. Since, however, in none of the pub-

TABLE 15.—COMPARISON OF THE FREQUENCY OF VIABLE MUTATIONS IN MALES, TREATED AS ADULTS AND AS LARVAE
 X-ray treatment. (Muller, 112)

Stage of treatment	Number of gametes tested	Number of viable sex-linked mutations	Number of viable autosomal dominants
Adult.....	2964	12	20
Larvae (3-4 days old).....	2651	1 (double)	1

TABLE 16.—THE FREQUENCY OF VIABLE MUTATIONS FROM GERM CELLS OF DIFFERENT STAGES

♂ ♂ X-rayed and mated at intervals of five days to fresh virgin ♀ ♀. (Timoféeff-Ressovsky, 178)

Age in days after irradiation	Number of tested gametes	Number of viable sex-linked mutations	Percentage of viable sex-linked mutations
1-15	3386	16	0.47
15-30	2892	12	0.42
Control	2971		

lished data is there any information as regards the frequency in which the original mutation occurred, there is no possibility of testing the hypothesis. Harris (72) has indicated that his results on lethals induced

TABLE 17.—VIABLE MUTATIONS FROM GERM CELLS OF DIFFERENT STAGES ♂♂ treated with radium, mated to fresh virgin ♀♀ at intervals of seven days, giving three broods in all. (Hanson and Winkelman, 71)

Age in days after treatment	Number of tested gametes	Number of viable mutations	Percentage of mutations
1-7	3,525	24	0.68
7-14	3,392	9	0.27
14-21	7,563	10	0.13
Total	14,480	43	0.30

TABLE 18.—COMPARISON OF THE FREQUENCY OF VIABLE SEX-LINKED MUTATIONS IN *DROSOPHILA MELANOGASTER*, IN THE GERM CELLS OF INDIVIDUALS TREATED WITH X-RAYS (1325 R) AT DIFFERENT STAGES OF DEVELOPMENT

Data of Moore (96)

Type treated	Number of gametes treated	Number of sex-linked mutations	Percentage of sex-linked mutations
Adult ♂♂.....	11,620	33	0.282 ± 0.03
Adult ♀♀.....	12,525	23	0.183 ± 0.026
71-72 hr. ♂ larvae.....	7,677	11	0.143 ± 0.029
71-72 hr. ♀ larvae.....	12,237	13	0.106 ± 0.018
35-36 hr. ♂ larvae.....	6,945	5	0.070 ± 0.020
35-36 hr. ♀ larvae.....	7,600	11	0.144 ± 0.028
Control ♂.....	13,673	1	0.007 ± 0.005
Control ♀.....	12,633	0	

in immature germ cells show that the growth of the gonad in *Drosophila* depends on an apical-cell mechanism, so that one of the products of division acts as a primordial germ cell. It is easy to see, as indeed Muller has shown (98), how difficult is the determination of the actual mutation rate in germ cells which have yet to divide; even without differential rates of multiplication, the number of mutants recovered is much less than those that occur, and the two percentages may be different, in the observed direction. There is as yet no evidence against the assumption that a gene is as likely to mutate in one tissue as another.

Timoféeff-Reesovsky (172), and more especially Patterson (130, 131, 133), have studied the frequency of mutation in the imaginal disks of *Drosophila*. Their technique was to irradiate larvae heterozygous for known genes, and to detect in the adults when they emerged mosaics for the characters affected. These mosaics must then be caused either by mutation of the gene in question or by some chromosomal change. In

males, for the X-chromosome, only mutation can be accountable. Somatic mutations occur and, as Patterson found, the extent of the size of the mosaic patch depends on the time of raying. The earlier the treatment, the greater the number of cell divisions subsequent to it, and the larger the mosaic patch accordingly. To compute the frequency of somatic mutation is a difficult matter; it is necessary to refer the mutation back to the total number of cells in the anlage when it occurred, in order to obtain a proper value. Patterson's attempt to reach a value in the percentage of the total number of adult units which have mutated is difficult to accept, even as a rough approximation. Further data are necessary.

It may be remarked that the same experiments have been used to demonstrate chromosome breakage in the somatic cells. The data are not quite satisfactory, owing to Stern's (168) recent demonstration of somatic crossing over which is probably also involved in Patterson's cases of somatic segregation (132). The data interpreted as resulting from chromosome breakage show suggestive similarities to those of Stern, and while it is probable that there is a high frequency of chromosome breakage somatically, further data are needed to show what proportion of the mosaics are due to somatic crossing over, and what to breakage. In the one case where a distinction between the two is possible in Patterson's experiments (the homozygous eosin female) no breakage was detected. Patterson's explanation on the grounds of genic balance relations which would give this result can be shown to be invalid.

On the whole, it appears that the existing data can best be understood in terms of similar rates of mutation in all cells. That this is not necessarily true in general is shown by the experiments of Demerec (18, 19, 20) on frequently mutating genes in *Drosophila virilis*, where definite genetic factors have been shown to influence the stability of the genes in different tissues.

THE MODE OF ACTION OF RADIATION

GENERAL CONSIDERATIONS

The previous sections have been devoted to a description of the relations of internal factors in the mutation process. This is essential for the understanding of the mode of action of radiation. But the proper analysis of the process from this point of view involves quantitative determinations of mutation rates under varied conditions of radiation.

It may be well first to consider what to expect in such experiments; how in general does radiation produce its effects and, among the different possibilities, which lead to different experimental results? The first result of radiation is the ionization of matter, the release of electrons; the resultant chemical reactions are to be attributed to this ionization. Secondary effects are then possible by way of interaction between prod-

ucts. On such a basis it must follow that the ultimate effects, except where secondary reactions bear other than a linear relation to the primary products, must be directly proportional to the quantity of radiation; moreover the simplest expectation would be that, with high-frequency radiation, variations in wave-length should make no difference, except-

TABLE 19.—A COMPARISON OF SEVERAL GROUPS OF DATA ON THE RELATION BETWEEN X-RAY DOSAGE AND PERCENTAGE OF LETHAL MUTATIONS IN THE X-CHROMOSOME OF *DROSOPHILA MELANOGASTER*

Dosage, r units	Oliver (125)	Timofféeff- Ressovsky (185)	Efroimson (43) 0.22 A	Scheelt- man (146) 1.75 A	Hanson, Heys, and Stanton (70)	Demerec (22)
300						
304						
385	1.42 ± 0.14					1.67 ± 0.39
445					1.50 ± 0.29 (40 kv.)	
637						5.19 ± 0.68
675					1.88 ± 0.33 (48 kv.)	
750		2.12 ± 0.46				
770	3.23 ± 0.25					
795					1.83 ± 0.34 (52 kv.)	
1125			2.6 ± 0.88			
1130				1.25 ± 0.53		
1200		3.76 ± 0.71				
1215						8.28 ± 1.05
1265					2.80 ± 0.46 (60 kv.)	
1500		4.23 × 0.71				
1540	{ 4.90 ± 0.43 4.38 ± 0.68					
1545					{ 3.36 ± 0.43 (70 kv.) 5.41 ± 0.63 (76 kv.)	
1635					5.47 ± 0.46 (67 kv.)	
1920					7.82 ± 0.80 (88 kv.)	
1995					6.91 ± 0.68 (80 kv.)	
2186						11.47 ± 1.07
2250			4.8 ± 1.2			
2260				5.98 ± 1.5		
2400		7.53 ± 1.16				
2570					6.23 ± 0.58 (95 kv.)	
3000		8.56 ± 1.12				
3038						14.41 ± 2.8
3080	9.87 ± 0.74					
3090					{ 9.10 ± 0.71 (95 kv.) 9.52 ± 0.85 (99 kv.)	
3600		10.69 ± 1.49				
4500			10.8 ± 1.2			
4520				5.88 ± 1.4		
4800		13.77 ± 1.74				
6000		15.62 ± 1.78				
6160	{ 16.09 ± 1.19 20.0 ± 2.63					
9000			22.9 ± 3.8			
9040				15.1 ± 1.7		

ing for the energy of the quantum absorbed to produce ionization. When, however, longer wave-lengths are used where selective absorptions may be expected, differences may be found. Furthermore, since radiochemical reactions usually have a temperature coefficient of 1, it should be found that there is no effect of temperature during irradiation. Any departure from these expectations indicates the presence of secondary reactions. These can, moreover, be studied by consideration of the time factor in exposure which evaluates the relative rates of the different reactions concerned; or by the consideration of the duration of the effect after successive cell generations.

THE RELATION BETWEEN INTENSITY AND MUTATIONAL EFFECT

The relation between dosage and effect is one of the most extensively studied of the problems attendant on the production of mutations by X-rays, involving as it does simultaneously an important practical and theoretical problem. In his earliest work, Muller (105) noted that the higher the dosage, the greater the mutational effect. Subsequently, the problem was studied in detail by various workers (cf. 22, 43, 52, 60, 70, 124, 125, 146, 152, 153, 185). Their data are given in Tables 19 and 19A, and in Fig. 6.

Within the range studied, the relationship is roughly linear for the whole group of data; in most of the individual cases, the fit to a straight line is quite good. At the upper dosages, a slight falling off occurs in some cases owing to undetected double lethals (cf. Timoféeff-Ressovsky, 185). Gowen and Gay (52) have plotted their data in the inverse fashion, considering the number of chromosomes which do not have lethals, a procedure which avoids this difficulty. They find an excellent fit to the exponential function which follows from this treatment of the data.

TABLE 19A.—THE RELATION BETWEEN X-RAY DOSAGE AND THE PERCENTAGE OF LETHAL MUTATION

K radiation of Cu and Cr, 34 kv., 4 ma. (Gowen and Gay, 52)

Dosage, r-units	Copper, 1.537 Å	Chromium, 2.285 Å
4,460	4.3 ± .6	6.8 ± 1.0
8,920	8.9 ± 1.3	12.4 ± 1.1
13,380	11.7 ± 1.5	19.3 ± 1.7
17,840	20.0 ± 2.1	26.5 ± 3.6
22,300	18.8 ± 2.9
26,760	29.2 ± 3.8	31.8 ± 6.7
31,220	35.0 ± 5.1	34.8 ± 6.7

The experiments of the different workers agree, on the whole, when the errors involved are considered. The data of Oliver and of Timoféeff-Ressovsky agree most closely. Efroimson (43) and Schechtman's (146)

data are somewhat off, but their numbers are lower. The observations of Gowen and Gay (53) and of Demerec (22), however, are distinctly different from the others. Demerec has paid particular attention to the measurement of intensity, having recently calibrated his dosimeter. When, however, his corrected dosage values are changed back to the uncorrected readings, his data agree quite well with those of Timoféeff-

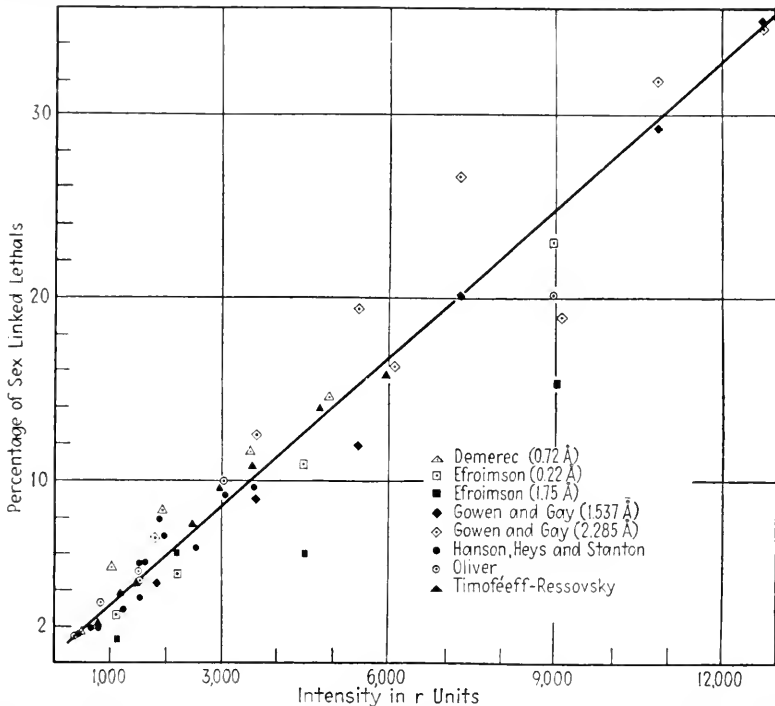

FIG. 6.—Percentage of lethals in the X-chromosome of *Drosophila melanogaster* in relation to the intensity of radiation. The data are taken from Tables 19 and 19a; for Demerec's values, the dosages of the table have been divided by 0.61. In the case of Gowen and Gay, the intensities have been divided by 2.44. The controls are not indicated; they may be found in Table 9.

Ressovsky and Oliver. One may suspect some systematic error on the part of the manufacturers of dosimeters, or in the calibration value which Demerec obtained from the Bureau of Standards. No such simple explanation can be used for the data of Gowen and Gay, which, however (see Fig. 6), when their dosage values are divided by the factor 2.44, fall into the same group as the other data.

The interpretation of the curve is not entirely obvious. If a single gene only were considered, the explanation generally used in the work with short-wave radiation (Crowther, 12a; Glocker, 48a), based on the change in the probability of a quantum hit at different dosages, would be quite simple. But in a population of genes, the problem becomes more complex. The evidence presented previously indicates that different

genes differ in their stabilities. Demerec has shown (23) that for the mutable miniature gene of *Drosophila virilis*, the effect of X-rays is very slight. Similar data have been obtained in *Zea Mays* by Stadler (166). It will be remembered, moreover, that the rough information given by the recurrence values of Table 1 indicates differences for some genes, differences which point in the same direction. It would appear that differences exist between the slopes of the dosage-effect curves of different genes. Now the curves of the lethal-mutation rate under discussion represent the sums of the curves of the genes composing the population. Their shape must obviously depend on the distribution of the slopes of the curves for individual genes. Both Stadler's and Demerec's data agree in indicating a low value of the slope for frequently mutating genes, which would tend toward a sigmoid curve for the whole population. It may be remarked that the gap between the control value—which should be the first point on the curve, but has not been so indicated in Fig. 6—and the first experimental value is considerable. Precisely this region is, however, most important for defining the nature of the curve.

With the lethal mutations, Oliver (125) has attempted to show that the distribution of lethals at different dosages is identical (Fig. 5). His data are not sufficient to settle the question. Moreover, without tests of the allelomorphism of the lethals, all that such tests can show is that the total number of genes available for mutation in a given section of chromosome is constant at the different dosages. The individual genes within the section, which still must constitute a large number, may still vary.

Timoféeff-Ressovsky (185) has tabulated the ratio of lethal to viable mutations at different dosages to distinguish "qualitatively" different effects. The ratio is sensibly the same at all dosages, which he takes to indicate that the type of mutation produced (visible or lethal) is independent of dosage. This does not, of course, bear on the question raised above, namely, the slope of the dosage-effect curve for individual loci. A quantitative determination of the relation between lethals associated with chromosome abnormalities and those which are not has been attempted by Oliver (125). Both types appear to vary linearly with the dosage, although whether the slopes are the same cannot be stated with assurance. This comparison is vitiated to a great extent by the large number of deficiencies undoubtedly present among the lethals not showing any major reduction in crossing over (cf. Patterson, 138). Since these are essentially small-scale chromosome aberrations, the comparison may well involve an identity. Except for the two cases mentioned no data are available for viable mutations where the question could be settled, albeit with great labor. Neither has there been made a comparison of the dosage-effect curves for lethals in the autosomes with those in the X-chromosome, which is more feasible.

When all these considerations are taken into account, the apparent linear relation loses its simplicity. It would seem that a detailed determination of the characteristics of the curve at very low intensities is necessary, and some practicable method must be found for dealing with the dosage-effect function for single genes.

THE RELATIVE EFFECTIVENESS OF DIFFERENT WAVE-LENGTHS

It has been shown clearly that all of the short-wave radiations are effective in the production of mutations. The first experiments of Muller (105) with X-rays were followed by the demonstration of Hanson and Heys (60) that radium emanations were effective in proportion to the ionization which they produced in air (Table 20). Likewise, Serebrovsky

TABLE 20.—THE RELATION BETWEEN THE IONIZATION PRODUCED BY RADIUM EMANATIONS AND THE PERCENTAGE OF LETHAL MUTATIONS IN THE X-CHROMOSOME OF *DROSOPHILA MELANOGASTER*
Data of Hanson and Heys (60)

Ionization proportional to	Thickness of lead filter, in.	Number of chromosomes tested	Number of lethal mutations	Percentage of lethal mutations
0.104	151	20	13.3
0.072	0.005	1045	99	9.4
0.058	0.010	600	46	7.6
0.046	0.019	559	34	6.0
0.035	0.039	514	24	4.6
0.026	0.078	697	24	3.4
0.017	0.156	1370	35	2.2
0.010	0.312	862	9	1.3

and Dubinin (152) found no differences between the effect of soft and hard X-rays. Later, Hanson, Heys, and Stanton (70) varied the wave-length by using kilovoltages from 40 to 99, and got an approximately linear relation with the ionization (Table 19, column 5) produced at each voltage. It may be remarked that they did not determine the identity of effect at the same ionization for different wave-lengths, a weakness in their experiments which vitiates their conclusions considerably. Later Schechtman (146) and Efromson (43) determined the dosage-effect relation at two different wave-lengths (1.5 and 0.2 Å) and found them sensibly identical (Table 19). Gowen and Gay (52) found no significant differences between the Cu and Cr radiation (1.5 and 2.2 Å, respectively) (Table 19A). Timoféeff-Ressovsky (185) has found equal effects at the same dosage in r-units, for different wave-lengths (Table 20). Conclusive data as regards the rays of radium are not as yet available (185).

TABLE 21.—THE EFFECTS OF EQUAL ENERGIES OF HARD AND SOFT X-RAYS ON THE PRODUCTION OF SEX-LINKED LETHAL MUTATION IN *DROSOPHILA MELANOGASTER* Timoféeff-Ressovsky (185)

Dosage and type of radiation	Number of chromosomes tested	Number of lethals	Percentage of lethals
± 3750 r, 25 kv., 0.5 mm. Al filter (± 0.41 Å).....	486	63	12.90 ± 1.52
± 3750 r, 160 kv., 0.25 mm. Cu + 3 mm. Al (± 0.07 Å).....	516	61	11.82 ± 1.45

All of these experiments involve gross lethal-mutation rate; they are subject to the same considerations, therefore, as were earlier met with in the dosage-effect experiments. Moreover, since the extraordinarily powerful short waves are involved, secondary radiation confuses the issue to a considerable degree. Thus, for example, the increase in mutation rate found by Medvedev (87) in flies containing lead over similarly irradiated normal flies is due to an increase in the amount of secondary radiation (Stadler, 164). This is not the case with the ultra-violet portion of the spectrum. Here, however, owing to the slight penetration, no certain effects were obtained (3, 4, 45, 56, 143a) until the recent experiments of Altenburg (5), in which the egg itself was irradiated while the germ cells were still localized in the polar cap. At this early stage, cells carrying an induced lethal would form a large number of the later mature germ cells, so that the appearance of the same mutation in several members of a family serves as a further check of its induction by the radiation. Eight such lethals were found in 108 groups of progenies from treated eggs, and one (possibly an experimental error) in the 110 control progenies. The further application of this method gives much promise for the discovery of selective effects at different wave-lengths.

Visible light has as far as is known no effect on mutation rates. Neither have effects been found with infra-red radiation (unpublished data), supersonic waves (Hersh, Karrer, and Loomis, 73), or an electrostatic field (Horlacher, 75; Schmitt and Oliver, 147). Hanson and Heys (67) have reported somatic modifications following exposure to alpha radiation from polonium, but no mutations.

It may be surmised, from an inspection of the experiments, that, in spite of the fact that the obvious things have been done to discover gross differences, any selective effects on particular genes would not have been found in this way. Such effects, which are the interesting and important ones, remain to be investigated although, as has been previously remarked, they are hardly to be expected in the spectral regions of shorter wave-length than the ultra-violet.

THE TIME FACTOR—SECONDARY REACTIONS

The relation of time and intensity has been given no exhaustive study; but the fact that similar relations have been obtained in experiments like those of Oliver (124, 125) where only time was varied, or of Hanson and Heys (60) where intensity was varied by means of lead filters, shows that the important element is the total amount of energy delivered. Timoféeff-Ressovsky (185) and Hanson and Heys (64) (Tables 22 and 23, respectively), have in particular put this to test over longer periods of time, and found again equal effects for equal amounts of energy.

TABLE 22.—THE EFFECTS OF EQUAL ENERGIES OF X-RAYS, APPLIED OVER DIFFERENT TIME INTERVALS, ON THE PERCENTAGE OF SEX-LINKED LETHAL MUTATION IN *DROSOPHILA MELANOGASTER* Timoféeff-Ressovsky (185)

Dosage and type of radiation	Number of chromosomes tested	Number of sex-linked lethals	Percentage
3600 r, in 15 min.....	493	54	10.91 ± 1.40
3600 r, in 6 hr.....	521	60	11.90 ± 1.39
3600 r, 6 treatments of 5 min. each at intervals of 24 hr.....	423	47	11.10 ± 1.52

TABLE 23.—LETHAL-MUTATION RATES IN THE X-CHROMOSOME OF *DROSOPHILA MELANOGASTER* WHEN THE SAME ENERGY IS APPLIED BUT THE TIME AND INTENSITY ARE VARIED Wild-type males treated (Hanson and Heys, 64)

Mg. Ra	Total time of exposure, hr.	Ionization proportional to	Dosage in total r-units	Number of chromosomes tested	Number of lethal mutations	Percentage of lethal mutations
300	½	0.2105	6,315.00	637	30	4.71 ± 0.56
4	37½	0.002807	6,315.75	636	30	4.71 ± 0.57
2	75	0.001403	6,315.30	626	29	4.57 ± 0.56
300	1	0.2105	12,630	626	61	9.74 ± 0.79
4	75	0.002807	12,631.5	622	60	9.64 ± 0.75
2	150	0.001403	12,627	619	59	9.53 ± 0.79
4	150	0.002807	25,263.00	366	74	20.22 ± 0.45

What such experiments mean is obvious: Subsequent to the initial radiochemical reactions, there are none which effectively modify them—either removal reactions such as are responsible for thresholds or “back-reactions.” In effect, the mutation process is pseudo-irreversible. The most striking evidence for this comes from the experiments of Muller (105), confirmed and extended by Harris (72; Table 24). Males which

are irradiated, and then kept from mating for long periods, produce as many mutations as they would have, if they had mated immediately. Were there a "back-reaction," fewer mutations would be expected from the sperm which were kept for a long time after irradiation.

TABLE 24.—THE EFFECT ON LETHAL-MUTATION RATE IN *DROSOPHILA MELANOGASTER* OF AGING SPERM AFTER X-RAY TREATMENT

Muller (105); Harris (72)

A. ♂♂ treated with X-rays, mated to virgin females, transferred to new culture bottles after six days (Muller)

Age of sperm	Number of gametes tested	Number of lethals	Percentage of lethals
1-6	856	81	9.3
6-12	997	111	12.1

B. ♂♂ treated with X-rays, isolated from females until final mating (Harris)

Experiment	Number of gametes tested	Percentage of lethals
Male removed after single copulation 1 to 10 hr. after treatment.....	220	10.0
Males held 4 days before mating.....	189	9.0
Males held 16 days without females before mating...	183	9.0

Similar conclusions follow from the experiments of Timoféeff-Resovsky (185; Table 22), Patterson (134; Table 25), and Serebrovsky and Dubinin (152). These workers have been interested in a comparison of the effects produced by a given amount of energy given in one dose, or split up into several. From the foregoing data, identical effects would be expected in the two sets of experiments; and indeed such is the case. Some caution is perhaps still necessary in accepting the conclusions completely; the detection of a difference, assuming one were present, depends upon the relation between the rates of the reactions concerned. Inspection of the tables makes it clear that the existing data are not sufficient to test the point thoroughly, a difficult problem indeed, and one which hardly seems profitable in view of the negative results of the experiments on the aging of treated sperm.

INDUCED CHANGES OF SUSCEPTIBILITY TO IRRADIATION

From the foregoing it would seem that the secondary processes, if they exist, are not easily approachable. The radiochemical process may, however, be studied by the analysis of the effect of environmental changes during radiation.

It has already been remarked that were simple radiochemical processes involved, the temperature coefficient of induced mutation rate should

TABLE 25.—A COMPARISON OF THE EFFECTS OF CONTINUOUS AND INTERRUPTED RADIATION IN *DROSOPHILA MELANOGASTER*
Patterson (134)

Dosage, r-units	Type of treatment	Number of chromosomes tested	Number of lethals	Percentage of lethals
1654	Continuous 14 min.	971	49	4.95
1654	Interrupted; 16 × 1 min. every 12 hr.	993	62	6.15
1654	Interrupted; 32 × 30 sec. every 6 hr.	981	71	7.14
2558	Continuous 8 min.	518	39	7.41
2558	Interrupted; 16 × 30 sec. every 12 hr.	345	45	12.95
1234	Continuous 10 min.	863	28	3.11
1220	8 × 1.25 min. every 24 hr.	876	31	3.33
1221	8 × 1.25 min. every 12 hr.	936	40	4.06
1219	8 × 1.25 min. every 8 hr.	856	34	3.76
1220	8 × 1.25 min. every 1 hr.	1014	32	2.94
1234	8 × 1.25 min. every 30 min.	962	33	3.22
864	Continuous 8 min.	919	22	2.19
872	8 × 1 min. every minute	980	21	1.93
123 mg. Ra	Continuous 12 hr.	544	58	10.44
123 mg. Ra	Interrupted, 12 × 1 hr., every 12 hr.	452	48	10.40

approximate 1. Muller (112) and Timoféeff-Ressovsky (185) have put this to the test, with identical results. The temperature coefficient is indeed 1, although curiously enough there is, in all three experiments, a slight excess of mutations at the lower temperature (Table 26). This may be an experimental accident, as Muller points out; its occurrence in three separate experiments is none the less interesting, and may perhaps

TABLE 26.—TEMPERATURE DURING IRRADIATION AND ITS EFFECT ON THE SEX-LINKED LETHAL-MUTATION RATE IN *DROSOPHILA MELANOGASTER*
Muller (112); Timoféeff-Ressovsky (185)

Conditions of irradiation	Number of tested gametes	Number of sex-linked mutations	Percentage of sex-linked mutations
(Timoféeff-Ressovsky)			
3000 r, at 10°C.....	401	37	9.22 ± 1.44
3000 r, at 35°C.....	368	30	8.15 ± 1.45
(Muller)			
3450 r ± at 8°C.....	67	22	33
3450 r ± at 34°C.....	120	32	27
2300 + r at 8°C.....	403	33	8.2
2300 + r at 34°C.....	208	13	6.2

indicate a difference in stability, similar to that noted by Gowen and Gay (53*a*) for the so-called "ever-sporting" eye colors.

Muller (112) has carried out experiments designed to test the effects of different physiological states on the induced-mutation rate. He found no significant differences between fed and starved, or virgin and impregnated females. More recently, Hanson and Heys (65, 66, 68, 69) have published a series of papers on this and related problems, which claim positive differences under various conditions. Their experiments await confirmation. One may surmise that the field is in pretty much the state of the general field of X-ray mutation before Muller's work.

THE QUESTION OF "DIRECT" EFFECTS

With the foregoing data in mind, the consideration of the mode of action of radiation in producing mutations becomes possible. The apparent linear relation between dosage and effect, the absence of evidence of any time factor, and the failure of an obvious effect of temperature during radiation, have in general led to the conclusion that the effect of radiation was directly upon the genes, causing intragenic changes. Moreover, specific experiments purporting to answer the question have been carried out by Muller (112) and Timoféeff-Ressovsky (177, 178).

They have tested the effect of treated cytoplasm on untreated chromosomes, by treating females, and testing the untreated paternal chromosome of the progeny for mutations. No significant differences were found in the large-scale experiments. Timoféeff-Ressovsky (177, 178) has also tested the behavior in later generations of treated chromosomes which had no immediate mutations. Were an indirect effect present, this might be delayed to later generations, so that successive generations from X-rayed progenies would show higher mutation rates. This experiment likewise gave a negative result.

Another test of a delayed effect consists of the search for small mutant patches in the progeny of treated individuals. Were the mutation delayed, this kind of mosaic should be found very frequently, since only a small number of cells of an individual would show a mutation which had arisen in late stages. Muller (112) reports negative results in this regard, which are confirmed by the later data of Moore (96). Yet in Moore's data there are indications that the problem is by no means solved.

Moore studied the "fractional" mutations, found as mosaics, of Muller (105). He has determined frequencies of fractional and complete mutations in the progenies of males and females treated at different stages in the life cycle. It is noteworthy, in contrast to the results of Patterson (139) on chromosome breakage, that even in the earliest stages, there is a frequency of fractional mutations comparable to that found when adults are treated. But the histological data of Kerkis (81) show

that at such stages the majority of the cells in the gonads, particularly of the female, are immature and subsequently will divide. It may be, as Harris (72) has indicated, that these divisions all concern a few apical cells. Unless this can be demonstrated, however, Moore's adaptation of Muller's original assumption that fractionals are to be accounted for as the result of a double chromosome cannot be accepted without emendation. If an apical-cell mechanism should be excluded, the choice is between the assumption of an aftereffect or the assumption that the chromosome is double, but segregation of sister chromonemata is random at mitosis, which would account for Moore's results. It may be noted, that on the latter assumption, complete mutations are really "double mutations," two genes mutating at once—an apparent contradiction to the evidence that only one of an allelomorphic pair mutates. This has been considered by Moore and an explanation attempted on the basis that the matrix within which the chromonemata are enclosed makes the chromosome a unit. This, however, is not quite satisfactory, since, according to Nebel (123), each chromonema has its own matrix. The hypothesis that sister chromonemata segregate at random may be tested as Sturtevant points out, by the data from somatic crossing over (Stern, 168). Until this is done, it is perhaps useless to speculate further in this direction.

Muller (113) recently has concluded that the induction of mutation by X-rays may be an indirect effect. His reasoning is as follows: chromosome breakages tend to be associated, since most translocations are mutual; this association precludes the possibility of a direct effect of X-rays on chromosome breakage; since, however, there is a linear relation between frequency of translocation and dosage, for translocation as for mutation, if in the one case the effect is indirect, it may be so in the other as well. The argument is far from convincing, although the conclusion may be correct. One may assume a direct effect on attachment, with the resultant double breakage a linear function of attachment; this would give the apparent linear relation observed, and would depend on a direct effect on the chromosome. But as has been pointed out, inferences from the shape of the dosage-effect curve give no satisfying conclusion as regards the mechanism of radiation effects. It is possible that the further analysis of group effects will be profitable in this connection. One may guess that both these and the translocation-group effects have their origin in chromosome movements during the growth of the male pronucleus. This is a time which has been untouched as yet by experiment, which is in *Drosophila* not easy to manage in this regard. Yet, so many things happen at this time that the lack of experiment is somewhat surprising, in view of the interest in the problem of direct effect.

It is, of course, a question whether any changes at all occur in the mature sperm, no matter how long it is aged. Timoféeff-Ressovsky

(178) has tested the mutation rate in young and old males, treated with identical doses of X-rays, and found no difference in mutation tests (Table 27). This he takes to indicate that mutation is not tied up to a particular stage of cell division. If, however, nothing really happens until the sperm gets into the egg, Timoféeff-Ressovsky's experiment has only negative value.

TABLE 27.—AGE OF MATURE SPERM AT TIME OF TREATMENT, AND THE FREQUENCY OF SEX-LINKED MUTATIONS IN *DROSOPHILA MELANOGASTER*
♂♂ treated with $3500 \pm r$ -units; Timoféeff-Ressovsky (178)

Experiment	Number of gametes tested	Number of lethal mutations	Number of "visible" mutations	Percentage of sex-linked mutations
Young ♂♂ irradiated and mated immediately.....	718	82	4	11.9
♂♂ kept without females for 15 to 20 days, irradiated and then mated immediately.....	539	57	3	11.1

From all these considerations it follows that the conclusion either of direct or of indirect effect cannot as yet be reached. The data are not critical in this regard. It may also be remarked, that it is difficult to conceive, when the mechanism of comparatively simple radiochemical reactions is considered, that the process of gene mutation should be affected by the release of electrons directly in the chemical sense, without the intervention of successive reactions.

THE CAUSES OF "SPONTANEOUS" MUTATION

The "spontaneous" mutations constitute a single point on the curve relating intensity to mutation rate. But, just as photosynthesis is dependent on other factors than light, other agents than short-wave radiation may be effective in changing the rate of mutation. The results from other treatments—references need not be given—have been negative in the main, with one exception. Yet it is not unlikely that the reason for the failure is the high degree to which the nucleus is protected from changes in the external environment. The one exception—changes of temperature—agrees with the rule, since the extent of penetration does not enter into such experiments.

The temperature experiments constitute only an indirect attack on the role of such other factors. Muller and Altenburg (114) and Muller (107) found evidence of a slight increase in mutation rate which indicated a temperature coefficient for the mutation process of the order of magnitude for chemical reactions. Later Goldschmidt (49), and following

his lead, Jollos (77, 78, 79), using much higher temperatures for a shorter time, obtained curious and specific results which have not been confirmed elsewhere. Rokitzky (145) and Plough and Ives (144), as well as Mackensen (Muller, 113) have found mutational effects which might have been expected on the basis of Muller's earlier data. The most striking thing about the experiments of Goldschmidt and of Jollos is the apparent specificity of the temperature effect. This would imply that at different loci the temperature coefficients of mutation process differ—a not improbable state of affairs. The closest approach to this is contained in the statement of Plough and Ives that recurrences are in their data somewhat more frequent for certain loci than for others, although they are by no means sure of the statistical significance of the data.

It is probable from these results, that temperature is effective in changing mutation rate. Yet the effect of radiation has been shown to be independent of temperature. This in itself does not indicate that the two types of mutation have different origins. It is conceivable that the effect of temperature is on the stability of genes with respect to radiation, in which case at the heavy dosages the effect of a rise of temperature would be inconsequential in comparison with the energy of the incident radiation, and so would be masked.

Following the discovery of the effect of radiation in producing mutations several workers suggested the possibility (not without a certain romantic flavor) that all mutations were due to radiation. On such a basis, the rapidity of the evolutionary process is in part dependent on the intensity of the surrounding short-wave radiation. Accordingly Babcock and Collins (7) and Hanson and Heys (63) felt the necessity of testing the potency of "natural" radiation in inducing mutations. They found, as might be expected, slight increases in the mutation rate corresponding to changes in incident radiation with which they were working. More to the point, however, are certain calculations of Muller and Mott-Smith (119), of Timoféeff-Ressovsky (176), and of Efrimson (43).

They have compared the total ionization to which *Drosophila* is subject during its life with that which would be expected were all the "spontaneous" mutations induced by "natural" radiation. This involves an extrapolation from the dosage-effect curve, on the assumption that the linear relation holds at low radiation intensities. They have found enormous discrepancies, certainly significant, between the observed and calculated mutation rates. But these discrepancies do not show that "it is accordingly probable that most mutations come about as the result of other causes" than radiation. They show at best that at low dosages the relation between intensity and effect is not linear. That this is quite likely has already been pointed out on other grounds (page 1240).

The essential experiment is one which Muller (112) had undertaken before the calculations discussed in the foregoing were completed and subsequently discontinued. If radiations constitute a *sine qua non* for the mutation process, when radiations are screened off there should be fewer—or no—mutations. This is a most difficult experiment—the spontaneous mutation being as low as it is. But it is a critical one. For without it (and, under certain not too improbable assumptions even with it) the idea is tenable that many factors are concerned with the stability of genes, but that the “accidents” which constitute a mutation always involve the effect of radiation.

THE NATURE OF THE MUTATION PROCESS

The discussion in the preceding section, as in those before it, dealt more or less descriptively with the characteristics of the mutation process. Most of the conclusions as to the “causes” of mutations rest on assumptions, explicit or implicit, as to the nature of the genes and the mechanism whereby they change. The assumptions fall into two categories: (a) the genes are independent units, and mutations are changes within the units; or (b) the chromosome is a continuum and changes in any portion thereof constitute mutations. A bridge between these is found in the position-effect hypothesis, which permits the expectation that a change in one gene modifies the behavior of its neighbors.

Under both of these broad categories there is a class of mutation theory which dates back to Bateson's “presence and absence.” Either mutations are inactivations or losses, total or partial, of the unit, or they are greater or lesser losses of portions of the chromosome. There is no point here in discussing the details of these hypotheses; much controversial blood has been spilled, and yet it would seem that the points at issue have no concern with the experiments which purport to study them. This is particularly evident in the studies on reverse mutations (59, 140, 182). These are important, as has been seen, in any attempt to understand the question of the direction of mutation. Actually they were undertaken largely in an attempt to show that the effect of X-rays on genes is not to destroy them; that is, to prove that the radiation-induced mutations are not deficiencies. The proof consists of the induction of mutations in both directions at the same locus. This could, however, only amount to proof if it is granted beforehand that mutation is a change *within* the gene, as Goldschmidt (51) has pointed out. Many mechanisms are conceivable, particularly with the intervention of a position effect (cf. Stadler, 166), whereby reverse mutations could occur and still be due to quantitative changes of some kind.

One of the most elaborate recent attempts to provide both a structure of the gene and a mechanism of mutation is the hypothesis of subgenes, due to Serebrovsky and Dubinin and their coworkers (1, 2, 35 to 39,

150, 151, 83, 154). These workers studied the bristle pattern in a series of multiple allelomorphs at the scute locus in *Drosophila melanogaster*. It seemed at first as if the bristles could be arranged in a specific linear order and that the different allelomorphs affected the bristles of this order in blocks. Serebrovsky and Dubinin then assumed that the arrangement of the subgenes in the chromosome corresponded to that of the bristles in the linear series. In this way each of the allelomorphs was due to the simultaneous change (loss at first) of neighboring subgenes. Later work of Dubinin (39) and of Sturtevant (170a) has shown that the original linear seriation does not hold and (Sturtevant) that different seriations are required at different temperatures. In the meantime, Sturtevant and Schultz (171) were concerned to show that the premise of the hypothesis—the identification of a developmental pattern with gene structure—is untenable. Both they and Goldschmidt (50) suggested developmental interpretations, which have been rejected by Dubinin and Friesen (40). It may well be that the specific developmental interpretations are faulty; bristle pattern in *Drosophila* is little understood. But this in itself emphasizes the danger of projecting developmental data on to the gene, without a clear knowledge of what is under discussion.

One may perhaps note a significant contrast in the primary interests of the participants in the presence or absence controversy. The modern proponents of the theory are chiefly interested in simplicity as far as concerns the theories of what genes do. Their adversaries, on the other hand, are most engaged with the evolutionary process, which they cannot imagine without *qualitative* changes in genes. Indeed, it has been stated that the evolution of genes “implies the possibility of qualitative change . . . as a necessary condition.” The periodic table of chemical elements may, however, be recalled. Here is an example of the results of *quantitative* changes which may then, a priori, suffice to give an extensive enough array of units for any evolution. Moreover, the analogy is useful in another sense, the distinction between qualitative and quantitative changes in genes is a relatively useless one unless it is sufficiently specified so that predictions can be made. Now the specifications which are required to make an adequate definition we are not at all prepared to give. The methods used all involve inferences from phenotypic changes to the structure of the gene, and the arguments used against Serebrovsky and Dubinin’s subgenes apply equally well to the more recent attempts to test the “molecular” structure of the gene (Demerec, 21a). This is particularly the case when the introduction of the position-effect hypothesis into the field is considered. Mechanical displacements and molecular changes become effectively one, as far as the experiments to date are concerned. It is patent that new methods must be devised, which will deal with the genes by more specific methods than those now available before it is profitable to discuss gene structure.

The consideration of the stabilities of the genes, however, is made possible by the existing experiments, and even leads to certain direct inferences as regards the evolutionary process. As has already been shown, it is possible that the analogy of the Galton polygon holds in the quantitative relations of the mutations at the white locus in *Drosophila*; that the frequency with which mutation to a given allelomorph occurs, is a direct function of the stability of that gene itself. It is possible that further studies in this direction may establish this relation definitely for many genes and give it a meaning in terms of reaction velocities or of energy relationships. From the studies of reverse mutations it definitely follows that the normal allelomorph, which is prevalent in a population, is for many genes maintained against a mutation pressure which tends to replace it by more stable allelomorphs. This is not surprising, in view of the calculations of Haldane, Wright, and Fisher on the role of mutation pressure in mendelian populations. However, it also suggests that there is a large population of genes whose normal allelomorphs are the most stable of the possible series; and of these we are very unlikely to obtain mutations.

Such considerations are of the utmost importance in any attempt to calculate the size and number of the genes. The ambitious attempt of Gowen and Gay (52), in particular, which gives a figure seven times higher than that of the preceding computations (92, 108), fails because of the use of lethal genes, not tested for recurrence. These have been shown by Patterson to occur on the average seven times as frequently as the viable mutations at the same locus. Now the calculation of the number of genes depends on the frequency of recurrence of viable mutations (Muller, 108) from which the total number of genes may be obtained. Gowen and Gay by assuming that "lethal genes" are per se different from others, and so multiplying their value for "visible" mutation fall into serious error, which results in their high figure. There is now some reason to believe that a direct cytological check may be possible in the chromosomes of the salivary glands of the *Drosophila* (128). But until this is possible, the distribution of the stabilities of genes must be taken into account in any such calculation; and the determination of their size (Sa, 52) on the assumption of direct electron hits certainly awaits an elucidation of the mutation reaction.

It is a pleasure to record the stimulus of frequent discussion with Drs. A. H. Sturtevant and Th. Dobzhansky. I am also indebted to Miss E. M. Wallace for help with the preparation of the figures.

REFERENCES

1. Agol, I. J. Evidence of the divisibility of the gene. *Anat. Rec.* **47**: 385. 1930. (Abstr.)
2. Agol, I. J. Step allelomorphism in *Drosophila melanogaster*. *Genetics* **16**: 254-266. 1931.

3. ALTENBURG, E. The limit of radiation frequency effective in producing mutations. *Amer. Nat.* **62**: 540-45. 1928.
4. ALTENBURG, E. The effect of ultra-violet radiation on mutation. *Anat. Rec.* **47**: 383. 1930. (Abstr.)
5. ALTENBURG, E. The production of mutations by ultra-violet light. *Science* **78**: 587. 1933.
6. ASTAUROFF, B. L. The experimental production of mutations in the silk worm (*Bombyx mori* L.). I. *Zeitsch. Biol.* **2**: 116-131. 1933. (Russian.)
7. BABCOCK, E. B., and J. L. COLLINS. Does natural ionizing radiation control rate of mutation? *Proc. Nation. Acad. Sci.* **15**: 623-28. 1929.
8. BAGG, H., W. C. MACDOWELL, and E. M. LORD. Further experiments with X-rayed mice and their descendants. *Anat. Rec.* **31**: 342. 1925. (Abstr.)
9. BRIDGES, C. B. Aberrations in chromosomal materials. *Eugenics, Genetics and Family* **1**: 76-81. 1923.
10. BRIDGES, C. B. The translocation of a section of chromosome-II upon chromosome-III in *Drosophila*. *Anat. Rec.* **24**: 426-427. 1923. (Abstr.)
11. BURKART, A. Investigaciones genéticas sobre una nueva mutacion de *Drosophila melanogaster* determinante de excepciones hereditarias. *Revista de la Facult. Agron. Veterin.* **2**: 393-490. 1931.
- 11a. BURKART, A., and CURT STERN. Untersuchungen über eine spontane Chromosomenverlagerung bei *Drosophila melanogaster*. *Zeitsch. Indukt. Abstamm. und Vererbungsl.* **64**: 310-325. 1933.
12. CHALMERS, R. ELIZABETH. Mutations and freaks from X-rayed males of *Habrobracon*. *Anat. Rec.* **47**: 394. 1930. (Abstr.)
- 12a. CROWTHER, J. A. The action of X-rays on *Colpidium colpoda*. *Proc. Roy. Soc. [London] B* **100**: 390-404. 1926.
13. DEMEREC, M. Miniature-alpha—a second frequently mutating character in *Drosophila virilis*. *Proc. Nation. Acad. Sci.* **12**: 687-90. 1926.
14. DEMEREC, M. Magenta-alpha—a third frequently mutating character in *Drosophila virilis*. *Proc. Nation. Acad. Sci.* **13**: 249-253. 1927.
15. DEMEREC, M. The behavior of mutable genes. *Proc. V. Internat. Cong. Genet. Zeitsch. Indukt. Abstamm. und Vererbungsl. Sup.* **1**: 234-260. 1928.
16. DEMEREC, M. Mutable characters of *Drosophila virilis*. I. Reddish-Alpha Body character. *Genetics* **13**: 359-88. 1928.
17. DEMEREC, M. Genetic factors stimulating mutability of the miniature-gamma wing character of *Drosophila virilis*. *Proc. Nation. Acad. Sci.* **15**: 834-38. 1929.
18. DEMEREC, M. Changes in the rate of mutability of the mutable miniature gene of *Drosophila virilis*. *Proc. Nation. Acad. Sci.* **15**: 870-76. 1929.
19. DEMEREC, M. A genetic factor affecting germinal mutability of miniature-alpha wing character of *Drosophila virilis*. "The Laws of Life" memorial volume for Prof. V. Ružička. Pp. 45-57. Prague. 1930.
20. DEMEREC, M. Changes in the instability of miniature-3 gene of *Drosophila* during ontogeny. *Proc. VI. Int. Cong. Genet.* **2**: 43. 1932.
21. DEMEREC, M. Rate of instability of miniature-3 gamma gene of *Drosophila virilis* in the males, in the homozygous and in the heterozygous females. *Proc. Nation. Acad. Sci.* **18**: 656-58. 1932.
- 21a. DEMEREC, M. What is a gene? *Jour. Hered.* **24**: 368-378. 1933.
22. DEMEREC, M. The effect of X-ray dosage on sterility and number of lethals in *Drosophila melanogaster*. *Proc. Nation. Acad. Sci.* **19**: 1015-1020. 1933.
23. DEMEREC, M. The effect of X-rays on the rate of change in the unstable miniature-3 gene of *Drosophila virilis*. *Proc. Nation. Acad. Sci.* **20**: 28-29. 1934.

24. DOBROVOLSKAIA-ZAVADSKAIA, N. A. Étude sur les effets produits par les rayons X dans le testicule de la souris. Arch. Anat. Microsc. **33**: 396-438. 1927.
25. DOBROVOLSKAIA-ZAVADSKAIA, N. A. L'irradiation des testicules et l'hérédité chez la souris. Arch. Biol. **38**: 457-501. 1928.
26. DOBZHANSKY, TH. Genetical and cytological proof of translocations involving the third and fourth chromosomes of *Drosophila melanogaster*. Biol. Zentralbl. **49**: 408-419. 1929.
27. DOBZHANSKY, TH. A homozygous translocation in *Drosophila melanogaster*. Proc. Nation. Acad. Sci. **15**: 633-638. 1929.
28. DOBZHANSKY, TH. Translocations involving the third and the fourth chromosomes of *Drosophila melanogaster*. Genetics **15**: 347-399. 1930.
29. DOBZHANSKY, TH. Cytological map of the second chromosome of *Drosophila melanogaster*. Biol. Zentralbl. **50**: 671-685. 1930.
30. DOBZHANSKY, TH. Translocations involving the second and the fourth chromosomes of *Drosophila melanogaster*. Genetics **16**: 629-658. 1931.
31. DOBZHANSKY, TH. The baroid mutation in *Drosophila melanogaster*. Genetics **17**: 369-392. 1932.
32. DOBZHANSKY, TH. Cytological map of the X chromosome of *Drosophila melanogaster*. Biol. Zentralbl. **52**: 493-509. 1932.
33. DOBZHANSKY, TH., and A. H. STURTEVANT. Translocations between the second and third chromosome of *Drosophila* and their bearing on *Oenothera* problems. Carnegie Instn. Washington Publ. **421**: 29-59. 1931.
34. DOBZHANSKY, TH., and A. H. STURTEVANT. Change in dominance of genes lying in duplicating fragments of chromosomes. Proc. VI. Int. Cong. Genet. **2**: 45-46. 1932.
35. DUBININ, N. P. Studies on the phenomenon of step-allelomorphism in *Drosophila melanogaster*. I. Allelomorphs scute,¹ scute,² scute.³ Jour. Exp. Biol. **5**: 53-85. 1929. (Russian.)
36. DUBININ, N. P. Allelomorphentreppen bei *Drosophila melanogaster*. Biol. Zentralbl. **49**: 328-339. 1929.
37. DUBININ, N. P. Step-allelomorphism in *Drosophila melanogaster*. The allelomorphs achaete²-scute¹⁰, achaete¹-scute,¹¹ and achaete³-scute.¹³ Jour. Genet. **25**: 163-181. 1932.
38. DUBININ, N. P. Step-allelomorphism and the theory of centres of the gene, achaete-scute. Jour. Genet. **26**: 37-58. 1932.
39. DUBININ, N. P. Step-allelomorphism in *Drosophila melanogaster*. Jour. Genet. **27**: 443-464. 1933.
40. DUBININ, N. P., and H. FRIESEN. Die Unmöglichkeit einer Erklärung des Falls der Treppenallege scute vom Standpunkte der Goldschmidtschen physiologischen Theorie der Vererbung. Biol. Zentralbl. **52**: 147-162. 1932.
41. DUBININ, N. P., and B. N. SIDOROFF. Relation between the effect of a gene and its position in the system. Amer. Nat. **68**: 377-381. 1934.
42. DUNNING, WILHEMINA F. A study of the effect of X-ray radiation on occurrence of abnormal individuals, mutation rate, viability and fertility of the parasitic wasp *Habrobracon juglandis* (Ashmead). Genetics **16**: 505-531. 1931.
43. EFKOMSON, W. P. Die transmutierende Wirkung der X-Strahlen und das Problem der genetischen Evolution. Biol. Zentralbl. **51**: 491-506. 1931.
44. FRIESEN, H. Kettenmutationen. Zeitsch. Indukt. Abstamm. und Vererbungsl. **62**: 504-539. 1932.
45. GEIGY, R. Action de l'ultra-violet sur le pôle germinal dans l'oeuf de *Drosophila melanogaster*. (Castration et mutabilité.) Rev. Suisse Zool. **38**: 187-288. 1931.

46. GLASS, H. B. A study of dominant mosaic eye-color mutants in *Drosophila*. Proc. VI. Int. Cong. Gen. **2**: 62-63. 1932.
47. GLASS, H. B. A study of dominant mosaic eye-color mutants in *Drosophila melanogaster*. I. Amer. Nat. **68**: 107-114. 1933.
48. GLASS, H. B. A study of dominant mosaic eye-color mutants in *Drosophila melanogaster*. II. Jour. Genet. **28**: 69-112. 1933.
- 48a. GLOCKER, R. Quantenphysik der biologischen Röntgenstrahlenwirkung. Zeitsch. Physik **77**: 653-675. 1932.
49. GOLDSCHMIDT, R. Experimentelle Mutationen und das Problem der sogenannten Parallel-Induktion. Biol. Zentralbl. **49**: 437-448. 1929.
50. GOLDSCHMIDT, R. Die Entwicklungsphysiologische Erklärung des Falls der sogenannten Treppenallelomorphe des Gens *scute* von *Drosophila*. Biol. Zentralbl. **51**: 507-526. 1931.
51. GOLDSCHMIDT, R. Bemerkungen zur Kritik der quantitativen Natur multipler Allele. Bull. Labor. Gen. Leningrad **9**: 129-134. 1932.
52. GOWEN, JOHN W., and E. H. GAY. Gene number, kind and size in *Drosophila*. Genetics **18**: 1-31. 1933.
53. GOWEN, JOHN W., and E. H. GAY. Eversporting as a function of the Y-chromosome in *Drosophila melanogaster*. Proc. Nation. Acad. Sci. **19**: 122-126. 1933.
- 53a. GOWEN, JOHN W., and E. H. GAY. Chromosome constitution and behavior in eversporting and mottling in *Drosophila melanogaster*. Genetics **19**: 189-208. 1934.
54. GREB, R. J. Effects of X-radiation on production of mosaic males and on sex-ratio in *Habrobracon*. Amer. Nat. **67**: 88-93. 1933.
55. GRÜNEBERG, HANS. Ein Beitrag zur Kenntnis der Röntgenmutationen des X-Chromosoms von *Drosophila melanogaster*. Biol. Zentralbl. **49**: 680-694. 1929.
56. GUYENOT, E. Action des rayons ultra-violets sur *Drosophila ampelophila*. Loew. Bull. Scient. France et Belgique **48**: 160-169. 1914.
57. HALDANE, J. B. S. The species problem in the light of genetics. Nature **124**: 514-516. 1929.
58. HANSON, F. B. The effects of X-rays on productivity and the sex ratio in *Drosophila melanogaster*. Amer. Nat. **62**: 352-362. 1928.
59. HANSON, F. B. The effect of X-rays in producing return gene mutations. Science **67**: 562-563. 1928.
60. HANSON, F. B. Radiation-genetics (a review). Physiol. Rev. **13**: 466-496. 1933.
61. HANSON, F. B., and F. HEYS. An analysis of the effects of the different rays of radium in producing lethal mutations in *Drosophila*. Amer. Nat. **63**: 201-213. 1929.
62. HANSON, F. B., and FLORENCE HEYS. Duration of the effects of X-rays on the male germ cells in *Drosophila melanogaster*. Amer. Nat. **63**: 511-516. 1929.
63. HANSON, F. B., and FLORENCE HEYS. A possible relation between natural (earth) radiations and gene mutations. Science. **71**: 43-44. 1930.
64. HANSON, F. B., and FLORENCE HEYS. Radium and lethal mutations in *Drosophila*. Amer. Nat. **66**: 335-345. 1932.
65. HANSON, F. B., and FLORENCE HEYS. The relation of the induced mutation rate to different physiological states in *Drosophila melanogaster*. I. Amer. Nat. **67**: 127-135. 1933.
66. HANSON, F. B., and FLORENCE HEYS. The relation of the induced mutation rate to different physiological states in *Drosophila melanogaster*. II. Amer. Nat. **67**: 419-428. 1933.

67. HANSON, F. B., and FLORENCE HEYS. The effects of alpha-radiation from polonium on the developing eggs of *Drosophila melanogaster*. *Amer. Nat.* **67**: 567-571. 1933.
68. HANSON, F. B., and FLORENCE HEYS. The relation of the induced mutation rate to different physiological states in *Drosophila melanogaster*. III. *Amer. Nat.* **68**: 97-106. 1934.
69. HANSON, F. B., and FLORENCE HEYS. The relation of the induced mutation rate to different physiological states in *Drosophila melanogaster*. IV. *Amer. Nat.* **68**: 166-167. 1934. (Abstr.)
70. HANSON, F. B., FLORENCE HEYS, and E. STANTON. The effects of increasing X-ray voltages on the production of lethal mutation in *Drosophila melanogaster*. *Amer. Nat.* **65**: 134-143. 1931.
71. HANSON, F. B., and ELVENE WINKELMAN. Visible mutations following radium irradiations in *Drosophila melanogaster*. *Jour. Hered.* **20**: 277-286. 1929.
72. HARRIS, B. B. The effects of aging of X-rayed males upon mutation frequency in *Drosophila*. *Jour. Hered.* **20**: 299-302. 1929.
73. HERSH, A. H., E. KARRER, and A. L. LOOMIS. An attempt to induce mutation in *Drosophila melanogaster* by means of supersonic vibrations. *Amer. Nat.* **64**: 552-559. 1930.
74. HERTWIG, PAULA. Die künstliche Erzeugung von Mutationen und ihre theoretischen und praktischen Auswirkungen. *Zeitsch. Indukt. Abstamm. und Vererbungslehre* **61**: 1-35. 1932. (Rev.)
75. HORLACHER, W. R. An attempt to produce mutations by the use of electricity. *Science* **72**: 96-97. 1930.
76. JOHNSTON, OLA, and A. M. WINCHESTER. Studies on reverse mutations in *Drosophila melanogaster*. *Amer. Nat.* **68**: 351-358. 1934.
77. JOLLOS, V. Studien zum Evolutionsproblem. I. *Biol. Zentralbl.* **50**: 541-554. 1930.
78. JOLLOS, V. Genetik und Evolutionsproblem. *Verhandl. Deut. Zool. Ges.* 1931. 252-295.
79. JOLLOS, V. Weitere Untersuchungen über die experimentelle auslösung erblicher Veränderungen bei *Drosophila melanogaster*. *Zeitsch. Indukt. Abstamm. und Vererbungslehre* **62**: 15-23. 1932.
80. JOLY, J., and H. H. DIXON. Cosmic radiations and evolution. *Nature* **123**: 981. 1929.
81. KERKIS, J. Development of gonads in hybrids between *Drosophila melanogaster* and *Drosophila simulans*. *Jour. Exp. Zool.* **66**: 477-502. 1933.
82. KOSSWIG, CURT. Die experimentelle Erzeugung von Mutationen. *Naturwiss.* **18**: 561-565. 1930. (Review.)
83. LEVIT, S. G. Step-allelomorphism in *Drosophila melanogaster*. V. *Jour. Exp. Biol. (Russian)* **6**: 287-299. 1930.
84. LITTLE, C. C., and H. J. BAGG. The occurrence of four inheritable variations in mice and their possible relation to treatment with X-rays. *Jour. Exp. Zool.* **41**: 45-91. 1924.
85. LOEB, J., and F. W. BANCROFT. Some experiments in the production of mutants in *Drosophila*. *Science* **33**: 781-783. 1911.
86. MAJOR, J. W. The attack on the gene. *Scient. Monthly* **21**: 355-363. 1925.
87. MEDVEDEV, N. N. The effect of X-rays in combination with lead acetate on the production of mutations in *Drosophila melanogaster*. *Compt. Rend. Acad. Sci. [U.S.S.R.]* **5**: 1-7. 1933.
88. MOUR, OTTO, L. On the potency of mutant genes and wild type allclomorphs. *Proc. VI Internat. Cong. Genet.* **1**: 190-212. 1932.

89. MORGAN, T. H. The origin of nine wing mutations in *Drosophila*. *Science* **33**: 496-499. 1911.
90. MORGAN, T. H. The explanation of a new sex ratio in *Drosophila*. *Science* **36**: 718-719. 1912.
91. MORGAN, T. H. The failure of ether to produce mutations in *Drosophila*. *Amer. Nat.* **48**: 705-712. 1914.
92. MORGAN, T. H. On the mechanism of heredity. Croonian lecture. *Proc. Roy. Soc. [London]* **94**: 162-197. 1922.
93. MORGAN, T. H., C. B. BRIDGES, and A. H. STURTEVANT. The genetics of *Drosophila*. *Bibliog. Genet.* **2**: 1-162. 1925.
94. MORGAN, T. H., C. B. BRIDGES, and JACK SCHULTZ. The constitution of the germinal material in relation to heredity. *Carnegie Instn. Year Book* **32**: 298-302. 1933.
95. MOORE, W. G. The effects of X-rays on fertility in *Drosophila melanogaster* treated at different stages in development. *Biol. Bull.* **62**: 294-305. 1932.
96. MOORE, W. G. A comparison of the frequencies of visible mutations produced by X-ray treatment in different developmental stages of *Drosophila*. *Genetics* **29**: 209-222. 1934.
97. MULLER, H. J. Genetic variability, twin hybrids and constant hybrids, in a case of balanced lethal factors. *Genetics* **3**: 422-499. 1918.
98. MULLER, H. J. Further changes in the white eye series of *Drosophila* and their bearing on the manner of occurrence of mutation. *Jour. Exp. Zool.* **31**: 443-473. 1920.
99. MULLER, H. J. Variation due to change in the individual gene. *Amer. Nat.* **56**: 32-50. 1922.
100. MULLER, H. J. Recurrent mutations of normal genes of *Drosophila* not caused by crossing. *Anat. Rec.* **26**: 397-98. 1923. (Abstr.)
101. MULLER, H. J. The measurement of mutation frequency made practicable. *Anat. Rec.* **24**: 419. 1923. (Abstr.)
102. MULLER, H. J. Mutation. *Eugenics, Genetics and Family* **1**: 106-112. 1923.
103. MULLER, H. J. Quantitative methods in genetic research. *Amer. Nat.* **61**: 407-419. 1927.
104. MULLER, H. J. Artificial transmutation of the gene. *Science* **66**: 84-87. 1927.
105. MULLER, H. J. The problem of genic modification. *Zeitsch. Indukt. Abstamm. und Vererbungsl. Sup.* **1**: 234-260. 1928.
106. MULLER, H. J. The production of mutations by X-rays. *Proc. Nation. Acad. Sci.* **14**: 714-726. 1928.
107. MULLER, H. J. The measurement of gene mutation rate in *Drosophila*, its high variability, and its dependence upon temperature. *Genetics* **13**: 279-357. 1928.
108. MULLER, H. J. The gene as the basis of life. *Proc. Internat. Cong. Plant Sci.* **1**: 897-921. 1929.
109. MULLER, H. J. The method of evolution. *Scient. Monthly* **29**: 481-505. 1929.
110. MULLER, H. J. Heritable variations, their production by X-rays, and their relation to evolution. *Smithsonian Instn. Rept.* p. 345-362. 1929.
111. MULLER, H. J. Types of visible variations induced by X-rays in *Drosophila*. *Jour. Genet.* **22**: 299-334. 1930.
112. MULLER, H. J. Radiation and genetics. *Amer. Nat.* **64**: 220-251. 1930.
113. MULLER, H. J. Further studies on the nature and causes of gene mutation. *Proc. VI. Internat. Cong. Genet.* **1**: 213-255. 1933.

114. MULLER, H. J., and E. ALTENBURG. The rate of change of hereditary factors in *Drosophila*. *Proc. Soc. Exp. Biol. and Med.* **17**: 10-14. 1919.
115. MULLER, H. J., and E. ALTENBURG. A study of the character and mode of origin of eighteen mutations in the X chromosome of *Drosophila*. *Anat. Rec.* **20**: 213. 1921. (Abstr.)
116. MULLER, H. J., and E. ALTENBURG. Chromosome translocations produced by X-rays in *Drosophila*. *Anat. Rec.* **41**: 100. 1928. (Abstr.)
117. MULLER, H. J., and E. ALTENBURG. The frequency of translocations produced by X-rays in *Drosophila*. *Genetics* **15**: 283-311. 1930.
118. MULLER, H. J., and A. L. DIPPEL. Chromosome breakage by X-rays and the production of eggs from genetically male tissue in *Drosophila*. *British Jour. Exp. Biol.* **3**: 85-122. 1926.
119. MULLER, H. J., and L. M. MOTT-SMITH. Evidence that natural radioactivity is inadequate to explain the frequency of natural mutations. *Proc. Nation. Acad. Sci.* **16**: 277-285. 1930.
120. MULLER, H. J., and T. S. PAINTER. The cytological expression of changes in gene alignment produced by X-rays in *Drosophila*. *Amer. Nat.* **63**: 193-200. 1929.
121. MULLER, H. J., and T. S. PAINTER. The differentiation of the sex chromosomes of *Drosophila* into genetically active and inert regions. *Zeitsch. Indukt. Abstamm. und Vererbungslehre.* **62**: 316-365. 1932.
122. MULLER, H. J., and F. SETTLES. The non-functioning of the genes in spermatozoa. *Zeitsch. Indukt. Abstamm. und Vererbungslehre.* **43**: 285-312. 1927.
123. NEBEL, S. R. Chromosome structure in *Tradescantia*. *Zeitsch. Zellforsch. und Mikrosk. Anat.* **16**: 251-304. 1932.
124. OLIVER, C. P. The effect of varying the duration of X-ray treatment upon the frequency of mutation. *Science* **71**: 44-46. 1930.
125. OLIVER, C. P. An analysis of the effect of varying the duration of X-ray treatment upon the frequency of mutations. *Zeitsch. Indukt. Abstamm. und Vererbungslehre.* **61**: 447-488. 1932.
126. OLSON, A. R., and G. N. LEWIS. Natural radioactivity and the origin of species. *Nature* **121**: 673-674. 1928.
127. PAINTER, T. S. A cytological map of the X-chromosome of *Drosophila melanogaster*. *Science* **73**: 647-648. 1931.
128. PAINTER, T. S. A new method for the study of chromosome aberrations and the plotting of chromosome maps on *Drosophila melanogaster*. *Genetics* **19**: 175-188. 1934.
129. PAINTER, T. S., and H. J. MULLER. The parallel cytology and genetics of induced translocations in *Drosophila*. *Jour. Hered.* **20**: 287-298. 1929.
130. PATTERSON, J. T. The effects of X-rays in producing mutations in the somatic cells of *Drosophila melanogaster*. *Science* **68**: 41-43. 1928.
131. PATTERSON, J. T. X-rays and somatic mutations. *Jour. Hered.* **20**: 261-267.
132. PATTERSON, J. T. Somatic segregation produced by X-rays in *Drosophila melanogaster*. *Proc. Nation. Acad. Sci.* **16**: 109-111. 1929.
133. PATTERSON, J. T. The production of mutations in somatic cells of *D. melanogaster* by means of X-rays. *Jour. Exp. Zool.* **53**: 327-372. 1929.
134. PATTERSON, J. T. Continuous versus interrupted irradiation and the rate of mutation in *Drosophila*. *Biol. Bull.* **61**: 133-138. 1931.
135. PATTERSON, J. T. The production of gynandromorphs in *Drosophila melanogaster* by X-rays. *Jour. Exp. Zool.* **60**: 173-211. 1931.
136. PATTERSON, J. T. A new type of mottled-eyed *Drosophila* due to an unstable translocation. *Genetics* **17**: 38-59. 1932.

137. PATTERSON, J. T. A gene for viability in the X-chromosome of *Drosophila*. *Zeitsch. Indukt. Abstamm. und Vererbungslehre* **60**: 125-136. 1932.
138. PATTERSON, J. T. Lethal mutations and deficiencies produced in the X chromosome of *Drosophila melanogaster* by X-radiation. *Amer. Nat.* **66**: 193-206. 1932.
139. PATTERSON, J. T. The mechanism of mosaic formation in *Drosophila*. *Genetics* **18**: 32-52. 1933.
140. PATTERSON, J. T., WELDON BREWSTER, and A. M. WINCHESTER. Effects produced by aging and X-raying eggs of *Drosophila melanogaster*. *Jour. Hered.* **23**: 325-333. 1932.
141. PATTERSON, J. T., and H. J. MULLER. Are "progressive" mutations produced by X-rays? *Genetics* **15**: 495-578. 1930.
142. PATTERSON, J. T., WILSON STONE, SARAH BEDICHEK, and META SUCHE. The production of translocations in *Drosophila*. *Amer. Nat.* **68**: 359-369. 1934.
143. PATTERSON, J. T., and META L. SUCHE. Crossing over induced by X-rays in males. *Genetics* **19**: 223-236. 1934.
- 143a. PROMPTOV, A. N. The effect of short ultra-violet rays on the appearance of hereditary variations in *Drosophila melanogaster*. *Jour. Genet.* **26**: 59-74. 1932.
144. PLOUGH, H. H., and P. T. IVES. Heat induced mutations in *Drosophila*. *Proc. Nation. Acad. Sci.* **20**: 268-273. 1934.
145. ROKITZKY, P. T. Über das Hervorrufen erblicher Veränderungen bei *Drosophila* durch Temperaturwirkung. *Biol. Zentrabl.* **50**: 554-566. 1930.
146. SCHECHTMAN, J. L. The mutational effect and quantitative relationships of X-ray action. *Jour. Exp. Biol. (Russian)* **6**: 271-279. 1930.
147. SCHMITT, F. O., and C. P. OLIVER. Electrostatic radiation and genetic effects. *Amer. Nat.* **67**: 67-68. 1933.
148. SCHULTZ, J. X-ray effects on *Drosophila pseudoobscura*. *Genetics* **18**: 284-291. 1933.
149. SCHULTZ, J., and TH. DOBZHANSKY. The relation of a dominant eye color in *Drosophila melanogaster* to the associated chromosome rearrangement. *Genetics* **19**: 293-364. 1934.
150. SEREBROVSKY, A. S. A general scheme for the origin of mutations. *Amer. Nat.* **63**: 374-378. 1929.
151. SEREBROVSKY, A. S. Studies on step allelomorphism. IV. *Jour. Exp. Biol. (Russian)* **6**: 61-72. 1930.
152. SEREBROVSKY, A. S., and N. P. DUBININ. X-ray experiments with *Drosophila*. *Jour. Hered.* **21**: 259-265. 1930.
153. SEREBROVSKY, A. S., N. P. DUBININ, I. I. AGOL, W. N. SLIEPKOFF, and W. E. ALTSHULER. The origin of mutations through the influence of X-rays in *Drosophila melanogaster*. *Jour. Exp. Biol. (Russian)* **4**: 161-180. 1928.
154. SHAPIRO, N. I. Step-allelomorphism in *Drosophila melanogaster*. VII. *Jour. Exp. Biol. (Russian)* **6**: 347-364. 1930.
155. SHAPIRO, N. I. The influence of the age of germin cells on the origin of translocations in *Drosophila melanogaster*. *Jour. Exp. Biol. (Russian)* **7**: 340-348. 1931.
156. SHAPIRO, N., and M. NEUHAUS. A comparative study of the mutation process in the female and male of *Drosophila melanogaster*. *Zeitsch. Biol. (Russian)* **2**: 425-445. 1933.
157. SIDOROV, B. N. A new allelomorph of bobbed connected with a translocation from the right half of the X chromosome on the third chromosome in *Drosophila melanogaster*. *Jour. Exp. Biol. (Russian)* **7**: 15-27. 1931.

158. SIDOROV, B. N. On the question of X-ray effects on the mutation process in immature germ cells of *Drosophila melanogaster*. *Jour. Exp. Biol.* (Russian) **7**: 349-351. 1931.
159. SIVERTZEV-DOBZHANSKY, N. P., and TH. DOBZHANSKY. Deficiency and duplications for the gene bobbed in *Drosophila melanogaster*. *Genetics* **18**: 173-192. 1933.
160. SNELL, GEORGE D. The effect of X-rays on the fertility of the house mouse. *Proc. VI. Internat. Cong. Genet.* **2**: 188. 1932.
161. SNELL, GEORGE D. Genetic changes in the mice induced by X-rays. *Amer. Nat.* **67**: 81. 1933.
162. SNELL, GEORGE D. The production of translocations and mutations in mice by means of X-rays. *Amer. Nat.* **68**: 178. 1934. (Abstr.)
163. SNYDER, L. H. Roentgen rays, induced sterility and the production of genetic modifications. *Amer. Jour. Roent. and Radium Ther.* **14**: 241-244. 1925.
164. STADLER, L. J. Mutations in barley induced by X-rays and radium. *Science* **68**: 186-187. 1928.
165. STADLER, L. J. Genetic effects of X-rays in maize. *Proc. Nation. Acad. Sci.* **14**: 69-75. 1928.
166. STADLER, L. J. On the genetic nature of induced mutations in plants. *Proc. VI. Internat. Cong. Genet.* **1**: 274-294. 1933.
167. STANCATI, M. F. Production of dominant lethal genetic effects by X-radiation of sperm in *Habrobracon*. *Science* **76**: 197-198. 1932.
168. STERN, CURT. Crossing over and segregation in somatic cells of *Drosophila melanogaster*. *Amer. Nat.* **68**: 164-165. 1934. (Abstr.)
- 168a. STERN, CURT, and S. OGURA. Neue Untersuchungen über Aberrationen des Y chromosomes von *Drosophila melanogaster*. *Zeitschr. Indukt. Abstamm. und Vererbungsleh.* **51**: 547-87. 1931.
169. STURTEVANT, A. H. The effect of unequal crossing-over at the Bar locus in *Drosophila*. *Genetics* **10**: 117-147. 1925.
170. STURTEVANT, A. H. A further study of the so-called mutations at the Bar locus of *Drosophila*. *Genetics* **13**: 401-409. 1928.
- 170a. STURTEVANT, A. H. Scute. *Proc. VI. Int. Cong. Genet.* **2**: 228. 1932.
171. STURTEVANT, A. H., and JACK SCHULTZ. The inadequacy of the subgene hypothesis of the nature of the scute allelomorphs of *Drosophila*. *Proc. Nation. Acad. Sci.* **17**: 265-270. 1931.
172. TIMOFÉEFF-RESSOVSKY, H. A. Röntgenbestrahlungsversuche mit *Drosophila funebris*. *Naturwissensch.* **18**: 431-434. 1930.
173. TIMOFÉEFF-RESSOVSKY, N. W. The effect of X-rays in producing somatic genovariations of a definite locus in different directions in *Drosophila melanogaster*. *Amer. Nat.* **63**: 118-124. 1929.
174. TIMOFÉEFF-RESSOVSKY, N. W. Rückgenvariationen und die genovariabilität in verschiedenen Richtungen. I. *Roux' Archiv. Entwicklunsmech. Organ.* **115**: 620-635. 1929.
175. TIMOFÉEFF-RESSOVSKY, N. W. Das Genovariieren in verschiedenen Richtungen bei *Drosophila melanogaster* unter dem Einfluss der Röntgenbestrahlung. *Naturwissensch.* **18**: 434-437. 1930.
176. TIMOFÉEFF-RESSOVSKY, N. W. Die bisherigen Ergebnisse der Strahlengenetik. *Ergeb. Mediz. Strahlenforsch.* **5**: 130-228. 1930. (Review.)
177. TIMOFÉEFF-RESSOVSKY, N. W. Does X-ray treatment produce a genetic after-effect? *Jour. Hered.* **22**: 221-223. 1931.
178. TIMOFÉEFF-RESSOVSKY, N. W. Einige Versuche an *Drosophila melanogaster* über die Art der Wirkung des Röntgenstrahlen auf den Mutationsprozess. *Roux' Arch. Entwicklunsmech. Organ.* **124**: 654-665. 1931.

179. TIMOFÉEFF-RESSOVSKY, N. W. Verschiedenheit der "normalen" Allele der white-Serie aus zwei geographisch getrennten Populationen von *Drosophila melanogaster*. Biol. Zentralbl. **52**: 468-476. 1932.
180. TIMOFÉEFF-RESSOVSKY, N. W. Die heterogene Variationsgruppe "Abnormes Abdomen" bei *Drosophila funebris*. Zeitsch. Indukt. Abstamm. und Vererbungslehre. **62**: 34-46. 1932.
181. TIMOFÉEFF-RESSOVSKY, N. W. Rückgenmutationen und die Genmutabilität in verschiedenen Richtungen. III. Zeitsch. Indukt. Abstamm. und Vererbungslehre. **64**: 173-175. 1932.
182. TIMOFÉEFF-RESSOVSKY, N. W. Mutations of the gene in different directions. Proc. VI. Internat. Cong. Genet. **1**: 308-330. 1933.
183. TIMOFÉEFF-RESSOVSKY, N. W. Rückgenmutationen und die Genmutabilität in verschiedenen Richtungen. IV. Zeitsch. Indukt. Abstamm. und Vererbungslehre. **65**: 278-292. 1933.
184. TIMOFÉEFF-RESSOVSKY, N. W. Rückgenmutationen und die Genmutabilität in verschiedenen Richtungen. V. Zeitsch. Indukt. Abstamm. und Vererbungslehre. **66**: 165-179. 1933.
185. TIMOFÉEFF-RESSOVSKY, N. W. Einige Versuche an *Drosophila melanogaster* über die Beziehungen zwischen Dosis und Art der Röntgenbestrahlung und der dadurch ausgelösten Mutationsrate. Strahlentherapie **49**: 463-478. 1934.
186. VAN ATTA, E. A. Genetic and cytological studies on X-radiation induced dominant eye colors of *Drosophila*. Genetics **17**: 637-659. 1932.
187. WARD, LENORE. The genetics of curly wing in *Drosophila*, another case of balanced lethal factors. Genetics **8**: 276-300. 1923.
188. WEINSTEIN, A. The production of mutations and rearrangements of genes by X-rays. Science **67**: 376-377. 1928.
189. WHITING, A. R., and C. H. BOSTIAN. The effects of X-radiation on larvae in *Habrobracon*. Genetics **16**: 659-680. 1931.
190. WHITING, P. W. The production of mutations by X-rays in *Habrobracon*. Science **68**: 59-60. 1928.
191. WHITING, P. W. X-rays and parasitic wasps. Jour. Hered. **20**: 269-276. 1929.
192. WHITING, P. W. Mutants in *Habrobracon*. Genetics **17**: 1030. 1932.
193. WOSSKRESSENSKY, N. M. Beschleunigende Röntgenstrahlenwirkung und deren Vererbung. Trudy Vsesoj. sjezda po genetike i selekcii **2**: 199-204. 1930.

Manuscript received by the editor August, 1934.



XL

INDUCED MUTATIONS IN PLANTS

L. J. STADLER

*United States Department of Agriculture and
University of Missouri, Columbia*

Introduction. What radiations are effective? Species differences in mutability. The physical nature of transmutation by X-rays. References.

INTRODUCTION

The discovery by Muller (31) in 1927 of mutation induced by X-rays in *Drosophila* greatly stimulated interest in the possibilities of the experimental modification of heredity in plants. The partial control of heredity which the results of Muller's experiments seemed to promise probably would have its chief application in the breeding of plants, for economic plant breeding can make much more rapid and extensive use of advances in genetic knowledge than can economic animal breeding. The effects of penetrating radiations on genetic variability have now been investigated in a wide variety of species among the higher plants, and the results in general confirm those obtained by Muller with *Drosophila*.

In plants, as in the fruit fly, it is found that chromosomal irregularities of various types, as well as gene mutations, are a characteristic result of irradiation. This chapter is concerned primarily with the evidence regarding induced mutation; the grosser chromosomal variations occurring in irradiated plants are discussed separately in Papers XLI and XLII. The distinction, however, is in some degree arbitrary. "Mutation" and "chromosomal aberration" are not coordinate classes. Mutation implies a hypothetical change within the individual gene, or at any rate a change affecting no more than a single gene. But since the individual gene is invisible, the identification of a germinal variation as a mutation is a matter of inference—we assume from its genetic behavior that it is due to a change in a gene. A chromosomal variation, on the contrary, may be identified by direct examination of the chromosome, and there are instances of variations which from their genetic behavior were taken to be mutations and which on direct examination have turned out to be chromosomal variations. Thus in effect a mutation is simply a mendelizing variation that has not been proven to be the result of something other than a change in a single gene. It is the task of future investigation to determine to what extent such variations represent changes in the genes themselves.

Before the publication of Muller's results, several investigations of the genetic effects of penetrating radiations in plants were in progress and some positive results had been obtained. The work of Gager and Blakeslee (14) is especially noteworthy in this connection. These investigators treated young buds of *Datura Stramonium* by fixing within the ovaries tubes containing "radium emanation." Since the alpha and beta radiations were largely or wholly absorbed by the walls of the tubes, the results of the treatment are ascribed to the gamma radiation. A capsule treated at a stage when "reduction had certainly taken place in the pollen mother cells and almost certainly also in the megaspore mother cells" yielded a progeny of 113 plants, among which 20 were found to be chromosomal variants. These included a large number of trisomic forms corresponding to the types previously found in untreated *Datura* by Blakeslee and his coworkers and shown by them to be characterized by the presence of an extra chromosome of the normal complement. The increased frequency of occurrence of these types in the treated series is ascribed to nondisjunction induced by the treatment. In addition there were certain more complex chromosomal variants, notably a new type *Nubbin* which was shown by Blakeslee (4, 5) to carry two chromosomes of complex structure, each formed of parts of two nonhomologous chromosomes of the normal complement. To account for the occurrence of this type it is necessary to assume that some of the chromosomes in a germ cell of the treated plant had been broken and that the resulting chromosome fragments had become permanently attached in new combination. The proportion of chromosomal variants in the progeny grown from the treated capsule was about 40 times as great as that found in untreated material of the same pure line.

In the progeny tests of the chromosomal variants it was found that 2 of the 18 plants tested were heterozygous for new recessive genes. Apparently in the germ cells of the treated plant gene mutations as well as chromosomal aberrations had occurred. Although the number of mutations found was small, the occurrence of even these few instances was very suggestive, for in the very extensive previous work with the same strain no gene mutations whatever had been found in the progeny of diploid plants.

Thus the progeny of this single treated capsule of *Datura* included variants resulting from three diverse types of germinal variation, namely, change in the distribution of chromosomes, internal reorganization of chromosomes, and change in individual genes. Subsequent investigations have shown that these three types of germinal variation are induced by high-frequency radiation in a wide variety of forms, both plant and animal.

The study of the genetic effects of irradiation in *Datura* has been continued and extended by Blakeslee and his associates. This work

has been concerned primarily with the analysis of the chromosomal effects of irradiation. The results of these studies are discussed in Paper XLI. Additional instances of mutation induced by radium treatment are reported by Avery and Blakeslee (1) and Buchholz and Blakeslee (7, 7a).

Buchholz and Blakeslee studied abnormalities of pollen and pollen-tube growth in plants from radium-treated parents. The strain of *Datura Stramonium* used in their experiments was a diploid line derived from a haploid plant. Such a line is absolutely homozygous except for genes which may have mutated subsequent to the establishment of the diploid line. The radium treatments were applied to the mature pollen before pollination or to the pollen tubes growing in the style after pollination. Among the plants of the next generation 192 were tested for abnormal pollen-tube growth, by examining the styles of normal plants pollinated from the plants under test. Forty-eight plants showing abnormal pollen behavior were found. Two of these cases are described in detail. In one, about half of the pollen ordinarily fails to germinate or in some instances gives rise to pollen tubes which burst near the stigma. In the second case, the pollen germinates normally, but half of the grains produce slow-growing pollen tubes which commonly fail to accomplish fertilization. In both cases the variation is transmitted normally through the female germ cells. Since the chromosomes of the affected plants are apparently normal, the abnormalities are considered to be due to recessive genes, resulting from mutation induced by the radium treatment.

Genetic variations are induced in *Datura* similarly by X-ray treatment. Blakeslee *et al* (6) have briefly described various genetic effects of X-ray treatment of seeds of *Datura Stramonium*, including the production of a number of gene mutations.

A comprehensive series of investigations of the cytogenetic effects of both X-ray and gamma-ray treatments in *Nicotiana* has been carried out by Goodspeed (16 to 19), following the discovery of X-ray induced variation in *Nicotiana* by Goodspeed and Olson (20). Treatments were applied to young buds, mature pollen, dormant seeds, and young seedlings. Various species and varieties were used. In addition to a wide variety of chromosomal variants (which are discussed in Paper XLI), many gene mutations were found in the progeny of treated plants. Goodspeed (17) has described three apparent mutants of *N. Tabacum purpurea*. Two of these, pink-flower color and pistillody of the androeium, occurred in progenies of plants in which young buds were X-rayed, the third, albino seedlings, in the progeny of a plant grown from radium-treated seed. Later investigation (18, 19) indicated that the pink-flower variation resulted from the loss of a chromosome segment rather than from gene mutation.

Another solanaceous form which has been extensively used as material for genetical investigations, and in which genetic effects of irradiation have been studied, is the tomato (*Lycopersicum esculentum*). Lindstrom (28) has reported a study of variations appearing in the tomato following radium treatment of seeds, growing tips, and young fruits. Five mutant types inherited as simple monogenic recessives are described, three affecting chlorophyll characters and two morphological characters. Three of these arose in a pure line derived from a doubled haploid. In addition, a dwarfed and sterile type, which appeared, apparently as a recessive mutant, in the progeny of an irradiated plant of *Lycopersicum pimpinellifolium*, is described.

The genetic effects of X-rays on cotton (*Gossypium hirsutum*) have been investigated by Horlacher and Killough (21, 21a, 22, 23). In a preliminary account McKay and Goodspeed (30) have also reported the occurrence of variations following irradiation in cotton, but the genetic analysis of these variants has not yet been reported. Horlacher and Killough treated dry seeds with heavy doses of X-rays. In the following generation several mutations were found, including variations of leaf color, leaf form, and type of plant. These authors have recently submitted strong evidence for the occurrence of dominant "progressive" mutations as a result of irradiation. In a family characterized by "forked" leaf shape, a character inherited as a simple recessive (nn), and in families heterozygous for forked, irradiation has repeatedly induced the mutation of n to the normal allelomorph. Similarly in the case of virescent yellow-plant color (vv), known to be a simple recessive to the normal green, the treatment has induced mutation to the normal allelomorph V .

Mutations induced by X-rays in *Antirrhinum majus* have been reported by Stubbe (51, 51a, b, c). Spontaneous mutation in this species had been intensively studied by Baur (2) who found in one line a mutation rate of approximately 5 per cent, that is, 5 per cent of the plants tested proved to be heterozygous for a gene not present in the ancestry of the plant. The line used in Stubbe's experiments was apparently much less mutable, the frequency of mutation in the untreated control being about 1 per cent. About one-half of the spontaneous mutations affect flower-shape characters, and it was found that mutations of this class were not increased in frequency by the treatment. The mutations observed in the treated series were largely mutations affecting vegetative organs of the plant. Stubbe used X-rays of varying wave-length, including the so-called grenz rays, and obtained mutation by treatment of seeds, seedlings, and pollen, as well as young flower buds.

The investigations by Stein (48, 48a, 49, 50) of the effects of radium treatment in *Antirrhinum majus* also should be mentioned, although these were concerned chiefly with the analysis of the direct effects of irradiation on the plants treated, rather than with the permanent modi-

fication of the germ plasm. Stein reported characteristic modifications of the irradiated plants ("Radiomorphosen") which in general were not transmitted to the progeny. In some instances (49), however, similar defects were noted in the progeny of treated plants, and recent evidence (50) indicates that these may be inherited as if due to recessive gene mutation.

In the Gramineae several of the economically valuable cereal plants have been used in genetic experiments with X-rays and radium. Barley (*Hordeum* spp.), oats (*Avena* spp.), wheat (*Triticum* spp.), and maize (*Zea Mays*) have been used by Stadler (38 to 47) and wheat has been used also by Delaunay (10 to 13) and Sapéhin (36).

In the experiments with barley (38, 40, 43, 45a) mutation was induced by seed treatment with both X-rays and radium. In the first series of experiments 53 mutations were found among 2800 progenies tested, while no mutations were found among the 1500 control progenies tested. Since about 90 per cent of the induced mutations could be recognized in the seedling stage, seedling mutations alone were used as an index of mutation frequency in some of the later experiments in which high numbers of mutations were required for significant comparisons. More than 800 mutations affecting seedling characters were observed in these experiments. About 95 per cent of these affect chlorophyll characters of diverse types. The remainder include a wide range of morphological abnormalities. Treatment of both dormant and germinating seeds resulted in mutation, but the rate of mutation following treatment of actively germinating seeds was about eight times as great as that following similar treatment of dormant seeds. In both dormant and germinating seeds the mutation rate was roughly proportional to the total intensity of radiation applied. The frequency of induced mutation was not affected by temperature treatments applied either at the time of irradiation or during the period following. X-rays through a wide range of wave-lengths induced mutations of the same general type and at rates approximately proportional to the ionizing intensity of the radiation applied. Mutations were induced similarly by gamma rays of radium, beta rays of radiothorium, and cathode rays.

Similar treatments applied to common oats and common wheat have little or no effect on the frequency of seedling mutations (42). Common oats and wheat have 21 pairs of chromosomes, while common barley has 7 pairs. Related species of *Avena* and *Triticum* with 7 pairs of chromosomes (*Avena brevis*, *A. strigosa*, *Triticum monococcum*) responded to the treatment in the same way as barley. The difference in response between the 7-chromosome and the 21-chromosome species is considered the result of gene reduplication in the polyploid species.

Induced variations in wheat have been reported by Delaunay and by Sapéhin. Delaunay (10 to 13) X-rayed 50 ears of *Triticum vulgare albidum*, an awnless common wheat, and obtained from the progeny

eight variant types (in addition to certain "monstrous forms"). Six of these were found to be due to chromosomal aberrations. One ("awned") was considered "an undoubted case of locus mutation," and another ("squarehead") was considered possibly due to gene mutation. The eight variants all arose in the progeny from ears X-rayed at meiosis and later; a larger group from treatments applied at an earlier stage of development yielded no variant types. Sapéhin (36) has briefly reported the occurrence of numerous variants in the progeny of common wheat, of which the great majority were aberrant types, more or less sterile, but among which some apparent mutants of practical interest were included. The genetic analysis of these variants has not yet been reported.

Mutations have been induced in maize by X-ray treatment of pollen, young embryos, or seeds (45, 45a). This plant is less favorable material than barley for quantitative studies of mutation frequency, but because of its unique combination of genetic and cytological advantages it is much more favorable for the genetic analysis of the induced mutations. The treatments are applied to parent stocks differing in genes marking all 10 chromosomes. These are crossed and the F_1 plants are self-fertilized. The mutants segregate in F_2 progenies segregating also for the chromosome markers, and thus their linkage relations are indicated at once. The presence of the marker genes also permits the recognition in F_1 and F_2 of various types of chromosomal aberration occurring in the same progenies. These include deficiency, inversion, segmental interchange, and various modifications and combinations of these phenomena. The chromosomal effects of X-ray treatment in maize are discussed in Paper XLI. About 40 mutations affecting seed and seedling characters were found in experiments thus far reported. All of the mutations were recessive. They show normal linkage relations, and their occurrence is not correlated with that of the gross chromosomal alterations causing partial sterility.

WHAT RADIATIONS ARE EFFECTIVE?

The X-rays found to induce mutation in the experiments reviewed above were relatively "soft" or low-frequency radiations, in most cases those emitted at 50 to 100 kv. p. The results secured with this radiation were in general similar to those secured with gamma rays of radium, which correspond to extremely hard X-rays, of higher frequency than any obtainable with ordinary X-ray equipment. The so-called "grenz rays," which are very soft X-rays generated at 10 kv. p. and lower, induce mutation similarly (43, 51c). Apparently X-rays of any degree of hardness obtainable with present-day equipment are capable of inducing mutation.

The genetic effectiveness of radiations of lower frequency than the grenz rays has not been determined in plants. Between the grenz rays and the ultra-violet is a broad band of frequencies now being explored by physicists but not readily available for biological investigation. The ultra-violet is so highly absorbed by intervening tissue that it is difficult to apply significant intensities to the germ cells. Stubbe found no effect of ultra-violet treatment of buds on the frequency of mutation in *Antirrhinum*, but it is not certain that the radiation penetrated to the germ cells tested. Mutation induced by ultra-violet radiation has been reported in *Drosophila* (see Paper XXXIX).

Mutation is induced similarly by beta rays and cathode rays. Stadler (45a) reports mutations in barley induced by beta rays of radiothorium and by cathode rays, and Kopf, according to Lindstrom (28), found a mutation in the tomato following treatment with cathode rays. Beta rays and cathode rays are radiations of similar nature, fundamentally different from X-rays. They consist of streams of electrons moving at high velocity. However, the secondary radiation produced within the tissues by the absorption of X-rays is analogous in nature to beta rays, while the secondary radiation produced by the absorption of beta rays is analogous to X-rays. It is probable that the effective agent in both X-ray and beta-ray treatment is the same.

The relative effectiveness of X-rays of different degrees of hardness has been investigated by Stubbe (51c). Treatments were applied to the pollen of *Antirrhinum majus*, and the effect on mutation frequency determined by examination of F_2 progenies. The results are summarized in Table 1.

The percentage of mutations in excess of the control is somewhat lower in the series treated with soft X-rays, but the differences are obviously insignificant.

The relation of radiation intensity to frequency of induced mutation has been determined in several experiments. In barley mutation frequency was roughly proportional to dosage, in experiments in which both dormant and germinating seeds were X-rayed (44). A similar relation was reported by Stubbe (51b) for X-ray treatment of buds in *Antirrhinum*, but the experiments of the same author with pollen treatment of *Antirrhinum* (summarized in Table 1), show a very different result. Here the frequency of mutation increases with increasing dosage to 400 r, drops sharply at 800 r and 1600 r, and increases again at 3200 r. For each grade of radiation the course of the dosage curve is similar, although the numbers involved in the separate trials are too small to be convincing when considered individually. The percentage of mutants observed in the progeny of plants treated at 400 r was higher than that in the progeny of plants given eight times as large a dose. To account for this unexpected result Stubbe suggests that the mutations or chromo-

somal variations involved belong to two sharply separated classes. Variations of one class occur readily under light doses and tend to be lethal under heavier doses; those of the other class occur only under heavy treatment. In genetic experiments with radiation in other forms there has been no indication of such a dosage relation.

TABLE 1.—EFFECT OF GRENZ RAYS, SOFT X-RAYS, AND HARD X-RAYS ON MUTATION IN *ANTIRRHINUM MAJUS* (After Stubbe, 58)

Treatment	Kilovolts	Filter	Half-value layer	Mutation frequency						
				100 r	200 r	400 r	800 r	1600r	3200r	Total
Grenz rays...	8, 10	none	0.015–0.019 Al	9 ₅	2 ₂	8 ₃	4 ₅	2 ₄	3 ₄	19 ₄ 63
Soft X-rays...	30, 50, 70	none	0.05–0.08 Cu	2 ₁ 8	2 ₁ 0	3 ₁ 4	4 ₁ 2	1 ₆ 6	2 ₉ 1	18 ₆ 63
Hard X-rays...	{ 125	3 mm. Al	0.3 Cu }	2 ₉ 3	2 ₉ 7	3 ₉ 7	4 ₉ 7	1 ₄ 9	3 ₅ 0	17 ₄ 83
	{ 175	0.6 mm. Cu	0.85 Cu }							
Total.....				4 ₃ 06	8 ₂ 90	18 ₃ 30	12 ₃ 19	4 ₁ 79	8 ₁ 85	52 ₁ 609
Control.....										22 ₂ 179

SPECIES DIFFERENCES IN MUTABILITY

Although penetrating radiation induces mutation in organisms so diverse as *Drosophila* and *Habrobracon*, *Datura* and *Hordeum*, there are large differences in the frequency of induced mutation in different species of the same genus. The much lower mutation frequency of the polyploid species in *Avena* and *Triticum* has already been mentioned. On the other hand, Goodspeed (17) states that in *Nicotiana* the species *N. glutinosa* and *N. sylvestris*, which have 12 pairs of chromosomes, are much more difficult to alter by X-ray or radium treatment than the species *N. Tabacum* and *N. rustica*, which have 24 pairs of chromosomes. The lower mutability of the polyploid species of *Triticum* has been questioned by Sapêhin (36), who points out that relatively soft radiation was used in the experiments with *Triticum* by both Stadler and Delaunay. Using somewhat harder X-rays in treating *T. vulgare*, Sapêhin reports:

Der Erfolg war überraschend: Hunderte unter den Nachkommen traten in den verschiedensten Richtungen verändert auf. . . . Die überwiegende Mehrzahl der Mutanten (nicht alle!) sind Chromosomen-Aberranten und meist mehr oder weniger steril; viele sind im morphologischen Sinne defektiv, doch kommen einzelne starke, fruchtreiche Mutanten vor, die von praktischem Interesse sind.

These apparently contradictory results are probably to be explained on the basis of differences not in the quality of radiation applied but in the type of genetic variation found. Germinal variations may result from gross chromosomal modifications as well as from gene mutation, and in the polyploid species the former source is particularly important.

On a *a priori* considerations polyploidy would be expected to decrease the frequency of occurrence of variants due to gene mutation, but it would be expected to increase the frequency of those resulting from various sorts of chromosomal aberration.

The relation of polyploidy to both sources of germinal variation is a consequence of gene reduplication in the polyploid genotype. The chromosome complement of the polyploid species consists of two or more groups of chromosomes, each group analogous to the entire chromosome complement of related nonpolyploid species. Probably the genomes combined are never wholly identical, but in general they must be identical in a considerable proportion of the genes which they include. This proportion doubtless will differ widely in different polyploid species, depending on differences both in original constitution and in the extent of evolutionary change subsequent to the establishment of the polyploid. We have at present no sound basis for an estimate of the proportion of genes reduplicated in any specific instance.

Now, so far as the reduplicated genes are concerned, recessive mutation of a gene in one chromosome group will in general be masked by the unmutated duplicate gene in the other. Since almost all of the radiation-induced mutations in the nonpolyploid species are wholly recessive, this will result in the elimination of practically all *detectable* mutation of the reduplicated genes. Mutation of those genes which are present as dominants in only one of the chromosome groups of the polyploid will be readily detectable. Thus the polyploid with two groups of chromosomes, though it may have twice as many genes as a related nonpolyploid species, would ordinarily yield a smaller number of detectable mutations. In the polyploid with three groups of chromosomes, since the probability of reduplication of any given gene is even higher, the frequency of detectable mutations should be still lower. In the comparison of existing species it is, of course, impossible to compare the polyploid with its unchanged parent species, or to make accurate allowance for the changes which have occurred in the polyploid itself. However, a general relation of the type described may be expected to apply in the comparison of any species of the same polyploid series, and in interpreting the results of irradiation in polyploid species it must be assumed that a large proportion of the gene changes actually induced may be phenotypically undetectable.

On the other hand, the frequency of heritable variations due to chromosomal aberrations is increased rather than decreased in polyploids. In nonpolyploid species the loss of a part of the chromosome complement is usually—perhaps always—lethal to the gametophyte. Such losses, or deficiencies, are a very frequent result of irradiation. If the deficiency is induced in a mature parental germ cell or in somatic cells it is readily detectable, and in many instances the chromosomal segment affected

may be determined both genetically and cytologically. Since the deficiency is lethal to the gametophyte, deficient gametes are not produced by the deficient plant; its progeny therefore is entirely normal. Other frequent chromosomal effects of irradiation are reciprocal translocation and inversion. While these chromosomal rearrangements do not necessarily involve any loss of chromosomal material, they result in the production of gametophytes characterized by deficiency or by both deficiency and duplication. The deficient gametophytes are aborted in these cases also.

But in the polyploid species, since the gametophyte has more than a single set of chromosomes and genes, deficiency is not regularly lethal. The loss of a chromosome segment will be lethal only if the portion lost contains some essential gene or genes which are not duplicated in the other chromosome groups. Other losses will permit gametophyte development and the production of deficient gametes. These deficiencies will be transmitted and any phenotypic effects they may have will therefore be heritable. The various chromosomal effects of irradiation, which in nonpolyploid species result in partial sterility, will now constitute a source of induced germinal variations, resulting not from modified genes but from the deficiency or duplication of specific segments of the chromosomes. Among the variations of this class, those caused by chromosomal alterations which have no effect on the transmission of the gametes will be inherited as if due to a change within a gene.

The results of the experiments with polyploid and nonpolyploid species of *Triticum* and *Avena* are in harmony with these considerations. The frequency of mutations affecting seedling characters was determined in four species of each genus (42). In the species with 7 pairs of chromosomes mutations of this sort were frequent, as previously found in *Hordeum vulgare* which also has 7 pairs of chromosomes. In species with 14 pairs of chromosomes such mutations were much less frequent, and in species with 21 pairs of chromosomes they were extremely rare. Using the same species of *Triticum*, Tascher (see 46) found the frequency of partial pollen sterility induced by X-ray treatment to be related similarly to chromosome number. An X-ray treatment which resulted in partial sterility in a large percentage of the plants treated in *T. monococcum* (7 pairs) produced partial sterility in a much smaller proportion of the treated plants of *T. durum* (14 pairs) and in very few cases in *T. vulgare* (21 pairs). Partial sterility induced similarly in *Zea Mays* has been found to be due chiefly to deficiency and translocation (45). Presumably the same chromosomal modifications are induced in the *Triticum* species, both polyploid and nonpolyploid. In the latter the deficient germ cells are aborted; in the former many of them survive and transmit nonlethal deficiencies and duplications to the progeny. The very low frequency of induced partial sterility in the polyploid species indicates

that a surprisingly large proportion of the induced deficiencies must be viable.

The fact that induced variations inherited as typical mendelian characters are found in common wheat, therefore, is not proof of the occurrence of gene mutation in the polyploid species. If even large deficiencies fail to cause pollen abortion, it may be expected that among the minor deficiencies and duplications some will have no appreciable effect on gametic survival and will thus be transmitted as mendelian factors.

The phenotypic effects which may be produced by such chromosomal irregularities are not limited to the expression of genic unbalance resulting from the loss or addition of genes en masse. In addition to these (which may themselves be indistinguishable from the effects of changes in individual genes), the loss of a chromosome segment in a polyploid may, by "uncovering" a specific recessive, lead to the expression of a known mutant gene apparently not present in the stock before treatment. For example, in wheat, if the recessive gene *a* ("awned") is present in two of the three constituent genomes, but the corresponding dominant *A* (awnless) is homozygous in the other genome, the strain will be a true-breeding awnless wheat. If a chromosome segment including *A* is lost as a result of irradiation and the deficiency has no effect on viability, the deficient gametes will be *aa* and the nondeficient gametes *aaA*. The genetic effects of this change will be precisely the same as if the mutation had been a change from *A* to *a*. The fact that gametes deficient for an entire chromosome may be transmitted through both male and female gametophytes in hexaploid species as *Avena* and *Triticum*, as shown by Kihara (26), Huskins (24, 25), and Nishiyama (33, 34), makes it possible that wholly viable sectional deficiencies may be common in the progenies of irradiated plants of these species. Similarly Clausen and Goodspeed (8) and Lammerts (27) have shown that in *Nicotiana Tabacum* and *N. rustica* gametes lacking an entire chromosome may be transmitted, at least through the female gametophyte.

Goodspeed (17) has emphasized the possible chromosomal basis of apparent mutations induced by radiation in *N. Tabacum*. In a variant characterized by pink flower color, which behaved genetically as if due to gene mutation, Goodspeed (18, 19) has demonstrated cytologically the presence of attached chromosome fragments. The chromosomal aberrations responsible for the occurrence of these fragments may have been causally connected with the occurrence of the germinal variation.

THE PHYSICAL NATURE OF TRANSMUTATION BY X-RAYS

The basic problem in the study of the genetic effects of irradiation is the physical nature of the changes induced in the genes and chromosomes. This is fundamental not only to problems of induced mutation, but to the

larger problems of gene structure and behavior which underlie the whole field of genetics. How does the chromosome in which a mutation has been induced differ, physically or chemically, from an unaffected sister chromosome, and how has this difference been brought about?

The conventional picture of the material basis of germinal variation is a simple one. Each chromosome includes a number of structurally distinct elements, the genes, each of which plays a definite role in the life of the cell and may thus have a specific effect on the inherent characteristics of the individual. A germinal variation may be brought about in either of two ways: (a) by a change in the constitution of a specific gene, and (b) by the addition or removal of one or more chromosomes or chromosome fragments containing genes. Changes of the first type (mutations) are considered the sole source of qualitative differentiation of the germ stuff; they represent the replacement of old genes by new and different genes. Changes of the second type (chromosomal aberrations) are of various types and may involve the loss or addition of a large or a small number of genes. They are not directly concerned in the evolution of the gene, but in many instances they produce phenotypic variations due to change in the proportions of genes. Such variations are heritable, for they are transmitted with the modified chromosomes. Various types of variation due to chromosomal aberrations may be identified by characteristic peculiarities of genetic behavior. Various environmental factors have been found to influence the frequency of occurrence of certain types of chromosomal aberration, but penetrating radiation was the first which gave convincing evidence of an effect on gene mutation.

If the appearance of a new mendelizing variation may be considered proof of the origin of a new gene, there can be no doubt that irradiation of the chromosomes leads to the production of new genes. But, though the occurrence of a new gene may cause the appearance of a new mendelizing variation, it is evident that mendelizing variations may occur also as the result of other germinal changes. Any change in a chromosome which permits cell survival and normal chromosome distribution will be transmitted in the same way as a new gene. We have seen how, in polyploids, even gross chromosomal aberrations may produce variations of a mendelian type. Such spurious mutations may be detected by cytological means, and in organisms very well known genetically, deficiencies or duplications too small for cytological detection may sometimes be identified by genetic tests. But no plant species is sufficiently well known genetically to permit the systematic identification of deficiencies by genetic means. The *Drosophila* evidence shows that segmental losses may be of such small extent that the class of recognizable deficiencies may overlap the class of apparent mutations. In plants it is only on the assumption that deficiencies are invariably lethal to the gametophyte that it is possible to justify the description of viable mendelian variations

in general as gene mutations. This assumption is obviously invalid in the polyploid species, and is of doubtful validity in other species.

Since chromosomal alterations (particularly small deficiencies) are known to simulate gene mutation in some instances, and since irradiation regularly induces chromosomal alterations (including deficiencies), there is obvious ground for the suspicion that the apparent gene mutations induced by irradiation are in fact due to extragenic alterations. Are the apparent mutations merely typical chromosomal aberrations involving small or relatively unimportant portions of the chromosomes, which may be lost or reduplicated without lethal effect? Or are they changes of a different type (whether mechanical or chemical) which are necessary consequences or antecedents of the accompanying chromosomal aberrations? Or are the mutations wholly unrelated to the grosser chromosomal modifications except in the circumstance that both result from the chain of reactions initiated by irradiation? Whatever their relation to the induced chromosomal aberrations, are the induced mutations representative of mutation in general, or only of some limited class of mutation? If induced variations can be shown to include qualitative as well as quantitative changes in chromosome constitution, may the mendelizing variations as a group be assigned to the class of qualitative gene alterations? Or do the mendelizing variations include both intragenic and extragenic alterations?

Questions of this sort are the chief concern of current genetic investigations with radiation. None of the questions stated above can be given an unequivocal answer from the evidence now available. The experiments on mutation in *Drosophila* (see Paper XXXIX) have yielded more information of value in this connection than have the comparable experiments with plants, and the reader is referred to discussions of this evidence by Patterson and Muller (35) and by Muller (32). The evidence from plants, bearing on the nature of induced mutation, has been discussed by Stadler (46).

The evidence from plants may be summarized under three main heads: (A) evidence indicating types of mutation not affected by irradiation; (B) evidence relating the induced mutations to the induced chromosomal aberrations; and (C) genetic and cytological evidence bearing on the nature of specific induced mutations.

A. A striking characteristic of induced mutation in nonpolyploid plants is the extreme rarity, or perhaps total absence, of dominant mutation. This is in contrast to the experimental results in *Drosophila*, in which induced dominant mutations are fairly frequent. However, most of these dominant mutations, like most of the spontaneously occurring dominant mutations in *Drosophila*, are lethal when homozygous. Thus they correspond in genetic behavior to gametophytic lethals in plants. Numerous induced deficiencies with gametophytic lethal effect

have been found in plants, and some of these have phenotypic effects on the sporophyte when heterozygous. It therefore seems probable that the absence of induced dominant mutations in plants is due to the fact that all induced dominant variations are lethal to the gametophyte.

But dominant genes of regular genetic behavior and viability, such as the genes for plant colors and morphological characteristics which distinguish agronomic varieties, although sought in very extensive experiments with plants, have never been found to occur as a result of irradiation. On the contrary, viable mutations of mutant genes to the dominant wild type have been found to be induced with appreciable frequency in *Drosophila*.

Moreover, recessive mutation of various genes in plants also seems to be independent of radiation. The effect of the treatment on the frequency of mutation of a specific gene cannot be determined without information on the natural or spontaneous rate of mutation of the gene concerned. This has been determined for seven genes affecting endosperm characters in maize (44, 46). Radiation experiments indicate that only one of these genes is appreciably affected in mutation rate by heavy treatment with X-rays. Since these genes are an unselected sample, this result indicates that the proportion of recessive gene mutations affected by radiation may be small.

B. The parallel response of deficiencies and mutations to variations of dosage is shown by the experiments of Stadler (41, 45a) and Goodsell (15). The frequency of mutation increases as a linear function of the total intensity of radiation applied; that of deficiencies producing mosaic endosperm varies in the same way with the radiation intensity. Wide variations of temperature during irradiation are without effect on the frequency of induced mutation, and this is true also for endosperm deficiencies.

A more striking parallel is the similar reaction of the two types of genetic variation to metabolic activity of the cells irradiated. Mutation is induced by irradiation of wholly dormant tissue, but the frequency of mutation per unit of radiation intensity is much lower than in active tissue (43). The chromosomal aberrations resulting in partial sterility also occur in cells irradiated while dormant, and their frequency also is greatly reduced, approximately in the same proportion as that of mutation (46).

It is interesting to note also that mutations similar to those induced by irradiation seem to occur in connection with chromosomal aberrations due to other causes. Sprague (37) has found that exposure of the maize ear shortly after fertilization to the effects of an electromagnetic field results in the occurrence of endosperm mosaics and other chromosomal disturbances. In the progeny of plants from seeds given this treatment a few seedling mutations were found. Beadle (3) has described a strain of maize characterized by high frequency of translocation and other

chromosomal irregularities. Several seedling mutations were found also in this strain.

There is no evidence in plants of a direct connection between mutation and chromosomal rearrangement. In *Drosophila*, on the contrary, almost all translocations are lethal when homozygous, a fact accounted for by the assumption of lethal mutation at the point of breakage of the chromosome. In some instances viable mutations are found at or near a point of chromosome breakage. In maize, although both translocations and viable mutations are induced by irradiation, the evidence thus far available does not show any tendency of variations of the two types to occur in the same individual more often than would be expected by chance coincidence. Furthermore, the rather scanty evidence available indicates that lethal mutations do not commonly occur at the points of translocation in maize. This may be a consequence of gene duplication connected with the possible polyploid origin in maize (46) and may not be true of nonpolyploid species.

C. The direct study of specific mutations to determine whether they result from intragenic or extragenic changes involves many difficulties. If the mutation is due to a change in the constitution of the individual gene, it is hopeless with present technique to attempt to demonstrate a morphological or chemical difference in the region of the chromosome involved. The attempt to support this hypothesis, therefore, takes the form of demonstration that the mutant gene behaves in a manner inconsistent with a mechanical explanation.

The evidence from reverse mutation is most plausibly interpreted by the assumption that the induced mutations are intragenic. In addition to the evidence of induced reverse mutation in *Drosophila*, submitted by Patterson and Muller (35) and Timoféeff-Ressovsky (52), there is similar evidence of induced reverse mutation in plants in the studies of Horlacher and Killough (23).

On the other hand, if the apparent mutation is due to a nonlethal deficiency or duplication, it may be possible in exceptionally favorable instances to demonstrate cytologically the change in the chromosome. Though this would be impossible in the condensed chromosome (unless the chromosome region involved were astonishingly large), it might be possible in a thin-strand stage of the meiotic prophase, when the modified and the unmodified chromosomes are synapsed. The technique for the study of the maize chromosomes in the prophase of meiosis, developed by McClintock (29), permits the cytological identification of small structural alterations with a precision far beyond that possible in studies of the condensed chromosomes.

Cytological evidence recently secured shows that viable deficiencies are responsible for some of the apparent mutations induced by X-rays in maize. Typical deficiencies, as previously stated, are eliminated as lethals in the haploid gametophyte generation, while typical mutations

are fully viable in the gametophyte and thus are transmitted in full proportion to the next sporophyte generation. If the mutations are due to deficiencies which are without injurious effect in the haploid generation, there should also be intermediate variations due to deficiencies which though not lethal are still not fully viable. Among these there might be losses large enough to permit cytological identification. Stadler (47) has reported that there are many such intermediate variations, and several of these show the loss of chromosome segments long enough for cytological detection. For example, in one case described in detail, an apparent recessive mutation of the gene R^r was shown to be due to the loss of a chromosome segment including the locus of this gene. The deficiency in this case is transmitted with reduced viability by female gametophytes but is not transmitted by male gametophytes. In an induced recessive mutation of the gene Yg_2 , viable in both male and female gametophytes, Creighton (9) has shown that a small deficiency occurred which reduced the size of a "knob" known to be located very close to the locus of the gene Yg_2 . No deficiency could be seen in the chromonema, and evidence from other cases showed that the locus of the gene is not within the knob. The presumption is that the deficiency included the locus of Yg_2 and a part of the knob, but that the section of chromonema lost is too short for cytological detection.

The question of the physical nature of induced mutation has not yet received a satisfactory answer. It is clear that many of the variations identified by their genetic behavior as gene mutations are due to mechanical alterations analogous to the grosser chromosomal aberrations. But no mechanical explanation of reversible mutations has thus far been found, and the most plausible assumption is that these mutations are intragenic. Possibly germinal alterations of both types are included among the induced mutations; possibly mechanical alterations not yet understood are responsible for the reversible variations. This question must be left for future investigation.

REFERENCES

1. AVERY, A. G., and A. F. BLAKESLEE. Radium experiments with *Datura*. IV. (Abst.) *Anat. Rec.* **41**: 99. 1928.
2. BAUR, E. Untersuchungen über das Wesen, die Entstehung und die Vererbung von Rassenunterschiedungen bei *Antirrhinum majus*. *Bibliog. Genet.* **4**: 1-170. 1924.
3. BEADLE, G. W. A gene for stiecky chromosomes in *Zea mays*. *Zeitsch. Indukt. Abstamm. und Vererbungsl.* **63**: 195-217. 1932.
4. BLAKESLEE, A. F. The chromosomal constitution of Nubbin, a compound ($2n - 1$) type in *Datura*. *Proc. Nation. Acad. Sci.* **13**: 79-85. 1927.
5. BLAKESLEE, A. F. Nubbin, a compound chromosomal type in *Datura*. *Ann. New York Acad. Sci.* **30**: 1-29. 1927.
6. BLAKESLEE, A. F., A. D. BERGNER, S. SATINA, A. G. AVERY, J. L. CARTLEDGE, and J. S. POTTER. Analysis of *Datura stramonium* plants grown from seed exposed to x-rays. (Abst.) *Anat. Rec.* **44**: 281. 1929.

7. BUCHHOLZ, J. T., and A. F. BLAKESLEE. Radium experiments with *Datura*. I. Jour. Hered. **21**: 119-129. 1930. [See also (a) Anat. Rec. **41**: 98. 1928. (Abst..)]
8. CLAUSEN, R. E., and T. H. GOODSPEED. Inheritance in *Nicotiana tabacum*. The monosomic character "fluted." Univ. of California Publ. Bot. **11**: 61-82. 1926.
9. CREIGHTON, HARRIET B. Three cases of deficiency in chromosome 9 of *Zea mays*. Proc. Nation. Acad. Sci. **20**: 111-115. 1934.
10. DELAUNAY, L. Die Chromosomenaberranten in der Nachkommenschaft von röntgenisierten Ahren einer reinen Linie von *Triticum vulgare albidum*. Zeitsch. Indukt. Abstamm. und Vererbungslehre. **55**: 352-355. 1930.
11. DELAUNAY, L. N. Röntgenmutationen des Weizens (Ergebnisse eines dreijährigen Versuches Visnik. Prikl. Bot. (Zeitsch. Angew. Bot.). 5-14. 1930.
12. DELAUNAY, L. N. Resultate eines dreijährigen Röntgenversuches mit Weizen. Züchter **3**: 129-137. 1931.
13. DELAUNAY, L. N. The x-mutations in wheat. Trudy Lab. Gen. Acad. Nauk, USSR (Bull. Lab. Gen. Acad. Sci. USSR) **9**: 173-180. 1932.
14. GAGER, C. S., and A. F. BLAKESLEE. Chromosome and gene mutations in *Datura* following exposure to radium rays. Proc. Nation. Acad. Sci. **13**: 75-79. 1927.
15. GOODSPELL, S. F. The relation between x-ray intensity and the frequency of deficiency in the maize endosperm. (Abst.) Anat. Rec. **47**: 381. 1930.
16. GOODSPEED, T. H. The effects of x-rays and radium on species of the genus *Nicotiana*. Jour. Hered. **20**: 243-259. 1929.
17. GOODSPEED, T. H. Inheritance in *Nicotiana tabacum*. IX. Univ. California Publ. Bot. **11**: 285-298. 1930.
18. GOODSPEED, T. H. Die Bedeutung von quantitativen Chromosomenveränderungen. Naturwissensch. **23**: 476-483. 1931.
19. GOODSPEED, T. H. Cytogenetic consequences of treatment of *Nicotiana* species with x-rays and radium. Svensk Bot. Tidskr. **26**: 147-162. 1932.
20. GOODSPEED, T. H., and A. R. OLSEN. The production of variation in *Nicotiana* species by x-ray treatment of sex cells. Proc. Nation. Acad. Sci. **14**: 66-69. 1928.
21. HORLACHER, W. R., and D. T. KILLOUGH. Radiation-induced variation in cotton. Jour. Hered. **22**: 253-262. 1931. [See also (a) Anat. Rec. **51**: 112. 1931. (Abst..)]
22. HORLACHER, W. R., and D. T. KILLOUGH. Chlorophyll deficiencies induced in cotton (*Gossypium hirsutum*) by radiations. Trans. Texas Acad. Sci. **15**: 33-38. 1932.
23. HORLACHER, W. R., and D. T. KILLOUGH. Progressive mutations induced in *Gossypium hirsutum* by radiations. Amer. Nat. **67**: 532-538. 1933.
24. HUSKINS, C. L. On the genetics and cytology of fatuoid or false wild oats. Jour. Genet. **18**: 315-364. 1927.
25. HUSKINS, C. L. On the cytology of speltoid wheats in relation to their origin and genetic behavior. Jour. Genet. **20**: 103-122. 1928.
26. KIHARA, H. Cytologische und genetische Studien bei wichtigen Getreidearten mit besonderer Rücksicht auf das Verhalten der Chromosomen und der Sterilität in den Bastarden. Mem. Coll. Sci. Kyoto **1**: 1-200. 1924.
27. LAMMERTS, W. E. Inheritance of monosomics in *Nicotiana rustica*. Genetics **17**: 689-696. 1932.
28. LINDSTROM, E. W. Hereditary radium-induced variations in the tomato. Jour. Hered. **4**: 128-137. 1933.
29. McCLINTOCK, B. Cytological observations of deficiencies involving known genes, translocations and an inversion in *Zea mays*. Missouri Agr. Exp. Sta. Res. Bull. 163. 1931.

30. MCKAY, J. W., and T. H. GOODSPEED. The effects of x-radiation on cotton. *Science* **71**: 633. 1930.
31. MULLER, H. J. Artificial transmutation of the gene. *Science* **66**: 84-87. 1927.
32. MULLER, H. J. Further studies on the nature and causes of gene mutations. *Proc. VI Int. Congr. Genet.* **1**: 213-252. 1932.
33. NISHIYAMA, I. On hybrids between *Triticum spelta* and two dwarf wheat plants with 40 somatic chromosomes. *Botan. Mag. Tokyo* **42**: 154-177. 1928.
34. NISHIYAMA, I. Genetics and cytology of certain cereals. II. *Japanese Jour. Genet.* **7**: 49-102. 1931.
35. PATTERSON, J. T., and H. J. MULLER. Are "progressive" mutations produced by X-rays? *Genetics* **15**: 495-578. 1930.
36. SAPÉHIN, A. A. Röntgen-Mutationen beim Weizen (*Triticum vulgare*). *Züchter* **2**: 257-259. 1930.
37. SPRAGUE, G. F. Some genetic effects of electromagnetic treatment in maize. (Abst.) *Anat. Rec.* **47**: 382. 1930.
38. STADLER, L. J. A genetic analysis of maize. *Missouri Agr. Expt. Sta. Bull.* **256**. 69-71. 1927.
39. STADLER, L. J. Genetic effects of x-rays in maize. *Proc. Nat. Acad. Sci.* **14**: 69-75. 1928.
40. STADLER, L. J. Mutations in barley induced by x-rays and radium. *Science* **68**: 186-187. 1928.
41. STADLER, L. J. The rate of induced mutation in relation to dormancy, temperature, and dosage. (Abst.) *Anat. Rec.* **41**: 97. 1928.
42. STADLER, L. J. Chromosome number and the mutation rate in *Avena* and *Triticum*. *Proc. Nation. Acad. Sci.* **15**: 876-881. 1929.
43. STADLER, L. J. Some genetic effects of x-rays in plants. *Jour. Hered.* **21**: 3-19. 1930.
44. STADLER, L. J. The frequency of mutation of specific genes in maize. *Anat. Rec.* **47**: 381. 1930.
45. STADLER, L. J. The experimental modification of heredity in crop plants. I. *Sci. Agric.* **11**: 557-572. 1931. [*See also* (a) *Ibid.* **11**: 645-661. 1931. (Paper II.)]
46. STADLER, L. J. On the genetic nature of induced mutations in plants. *Proc. VI Int. Congr. Genet.* **1**: 274-294. 1932.
47. STADLER, L. J. On the genetic nature of induced mutations in plants. II. *Missouri Agr. Expt. Sta. Res. Bull.* **204**. 1933.
48. STEIN, E. Über den Einfluss von Radiumbestrahlung auf Antirrhinum. *Zeitsch. Indukt. Abstamm. und Vererbungsl.* **29**: 1-15. 1922. (*See also* (a) *Ibid.* **43**: 1-87. 1926.)
49. STEIN, E. Weitere Mitteilung über die durch Radium-Bestrahlung induzierten Gewebe-Entartungen in Antirrhinum (Phytokarzinome) und ihr erbliches Verhalten. *Biol. Zentralbl.* **50**: 129-158. 1930.
50. STEIN, E. Zur Entstehung und Vererbung der durch Bestrahlung erzeugten Phytokarzinome. *Zeitsch. Indukt. Abstamm. und Vererbungsl.* **62**: 1-13. 1932.
51. STUBBE, HANS. Untersuchungen über experimentelle Auslösung von Mutationen bei Antirrhinum majus. I. *Zeitsch. Indukt. Abstamm. und Vererbungsl.* **56**: 1-38. 1930. (*See also* for Papers II-IV (a) *Ibid.* **56**: 202-232. 1930; (b) **60**: 474-513. 1932; (c) **64**: 181-284. 1933.)
52. TIMOFÉEFF-RESSOVSKY, N. W. Mutations of the gene in different directions. *Proc. IV Internat. Congr. Genet.* **1**: 308-328. 1932.

INDUCED CHROMOSOMAL ALTERATIONS

T. H. GOODSPEED

During the past six years evidence has accumulated to indicate the cytogenetic significance of the alterations which chromosomes of plant and animal species have long been known to undergo as a result of treatment with high-frequency radiation. Before this period the extent of occurrence of quantitative chromosomal alterations under natural conditions had not been emphasized nor, in particular, had their possible significance in the origin of mutational processes been fully appreciated. It is now recognized that such chromosomal changes induced in plants by high-frequency radiation differ in frequency of occurrence rather than in kind from those found in nature. It is, therefore, possible to discuss them in terms of such classifications of chromosomal alterations as those of Bridges (8) or Belling (1). Thus, induced chromosomal changes may involve portions of chromosomes, whole chromosomes, or chromosome sets, and within these subdivisions examples under most of the specific categories recognized as occurring under natural conditions have been induced by high-frequency radiation. Thus instances of polyploidy and haploidy which involve alterations in sets of chromosomes have also occurred in radiation work. Similarly, the occurrence of polysomies, monosomies, fragment chromosomes, and compound chromosomes is not an infrequent effect upon whole chromosomes. Finally, the categories of alteration having to do with sections of chromosomes and involving chromosomal interchanges—translocation (simple and reciprocal)—deficiency, deletion, inversion, and duplication are products of treatment with high-frequency radiation.

Although the majority of these various types of chromosomal alterations in plants are primary products of the treatment, their occurrence is also to be assigned to secondary effects of initially induced chromosomal alteration. The accompanying chart (Fig. 1) indicates the relationship between primary and secondary effects of high-frequency radiation and the interrelations between them in the production of cytogenetic types. Thus, irradiation may lead directly to extensive nuclear disruption or to lethality, the latter being obtained secondarily via extensive nuclear disruption, via initially induced gene mutation, or via chromosomal reorganizations which are the direct products of treatment or occur as consequences of the monosomic or polysomic condition. Aneuploidy

may, as indicated, be directly induced or may arise as a result of gene mutation (asynapsis) or as a by-product of chromosomal reorganization, while monosomy and polysomy may themselves give triploidy. The dotted lines indicate that polyploidy and extreme nuclear disruption may possibly be secondary products of induced gene mutation. Thus, Stein (45b, 46b, 47) interprets her "phytocarcinome complex," which is characterized by these effects, as due to an induced mutation. Chromosomal reorganizations are indicated as the direct consequences of irradiation and may give rise in subsequent generations to haploidy, triploidy, and tetraploidy. In addition they are shown as a mode of

origin of gene mutations, a significant type of effect from the point of view of the origin of mutation.

In this connection the results of Stubbe (48) are significant. Using mature pollen of *Antirrhinum majus*, he compared mutation frequency after treatment with grenz (supersoft) rays and longer and shorter X-rays, the dosage in each case increasing in geometrical progression. That the curves obtained from the three treatments are directly comparable is interesting in other connections, but their present significance lies in their consistent and decided fall from a rapidly attained peak, followed by their rise. As to the nature of the

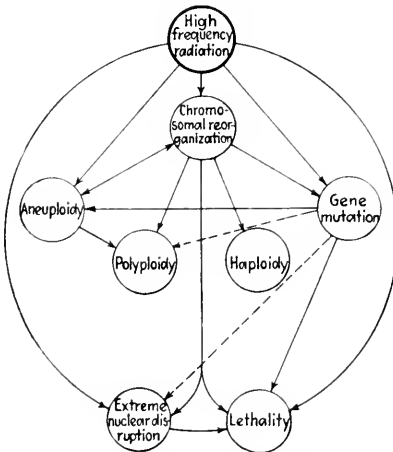

FIG. 1.—Chart illustrating primary and secondary effects of high-frequency radiation in inducing chromosomal alterations in plants.

mutations themselves, those responsible for the initial rise in the curve were similar or equivalent to those which had been observed in *Antirrhinum* under natural conditions. Stubbe's results may be interpreted as indicating that a series of qualitative (intragenic, chemical) changes were initially induced, followed by quantitative (extragenic, chromosomal) alterations productive of lethality and giving by-products of such extragenic alteration which behaved genetically as did the gene mutations first produced. Although Stubbe assigns all the mutations, which were identified without cytological study, to induced transgenation ("labile" vs. "stable" gene mutations), he recognizes that quantitative chromosomal alteration may, in part at least, have been responsible for their occurrence.

That structural alterations in plant chromosomes are readily induced by high-frequency radiation has long been recognized and the alterations themselves have been frequently described (cf. Koernicke, 24; Levine, 25; Pekarek, 35; Timefcéeff-Ressovsky, 49). Chromosomal "fragmentation"

and "clumping" are the most conspicuous effects. Complete "clumping" or fusion of nuclear constituents appears to be the ultimate product of a change in chemical composition of chromatin which originates either in general alterations in protoplasmic equilibria or in direct disruption of the nucleoplasm itself. Mature chromosomes share in this "clumping" effect which, when less severe, is apparently expressed in a tendency to what has been called "stickiness" and which produces temporary or more permanent unions between chromosomes in mitotic or meiotic stages.

In appearance, the cytoplasm has usually been described as showing little effect of high-frequency radiation. However, aberrations in formation and functioning of the achromatic figure are frequently reported and the familiar evidence that a certain period usually intervenes between irradiation and the production of visible induced nuclear effects, obviously suggests that the protoplast as a whole is concerned.¹ In this connection, a comparative study of the disposition and character of the nonvolatile mineral constituents of the cell (cf. Scott, 38; Goodspeed, unpublished) in irradiated and normal tissues after microincineration may possibly throw light on the extent and character of induced cytoplasmic vs. nuclear changes.

Recent investigations of effects of irradiation on nuclear structure deserve more attention because they not only give more definition to types of alteration previously described but in addition emphasize the genetic as well as the cytological significance of what is observed. In particular, it is being shown that the less obvious effects may be of greater genetic and evolutionary importance than the more complete and striking disruptions already known. Clearly, however, the former originate in the same types of disturbances of cellular equilibria as do the more obvious ones; indeed they represent intermediate products of processes culminating in nuclear disruption and lethality (cf. Fig. 1). Thus, fragmentation and fusion, long recognized as major cytological effects of irradiation, become primary agents in genetically significant chromosomal reorganization, when the processes involved in their production are not carried to their extreme and lethal expression.

That chromosomal fragmentation is the most frequent and initially important product of irradiation is commented upon by Lewitsky and Araratian (26). In *Secale cereale*, *Vicia sativa*, and *Crepis capillaris*, roots of seedlings X-rayed when one to two days old and fixed two days later showed many mitoses containing chromosomal alterations. In the fragmentation observed, the breakage usually occurred at any point distal to the insertion region. In *Crepis* it occurred at the insertion

¹ The relation between cytoplasmic energization, as expressed in anaphasic stresses, and the appearance of nuclear alterations has elsewhere been discussed (Goodspeed, 12).

region in 4 out of 20 cases, thus indicating that this is a point of weakness. The immediate origin of fragments was observed, in that, frequently, detached chromosome segments lay close together, indicating their recent derivation from the normal unit. That fragments lacking an insertion region are not propagated through a series of mitoses was indicated (a) by the complete absence of certain specific chromosome segments and (b) by the absence of "undifferentiated" fragments in mitoses observed a month after irradiation. Some fragments apparently possessed newly formed constrictions, but as these were not known to

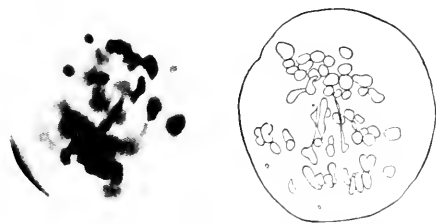

FIG. 2.—Chromosomal disruption appearing in first meiotic anaphase of PMC of *Nicotiana Tabacum* var. *purpurea*, 48 hr. after heavy X-radiation. (a) Photomicrograph; (b) camera lucida drawing of same PMC.

represent points of functional fiber attachments, no final evidence as to the possibility of a de novo origin of an insertion region was provided. In addition to fragmentation, the shortened condition of one chromosome and the elongation of another, in *Vicia* and *Crepis*, was interpreted in terms of translocation. The "association" of two chromosomes and the translocation of fragments from two chromosomes to a third were also reported. Yamamoto (50) has also figured fragmentation and fusion of chromosomes in PMC (PMC = pollen mother cells, EMC = embryo sac mother cells) of *Rumex acetosa* following X-radiation.

One of the most significant recent descriptions of the character of induced chromosomal alterations in plants is that of Navashin (32), who examined mitoses in root tips of young plants of *Crepis tectorum* grown from soaked seeds subjected to X-radiation. In this unusually favorable cytological material it was possible to determine the extent and character of the chromosomal reorganizations produced. Fragmentation was often followed by fusion of detached chromosome segments. Frequently chromosome fragments possessing "kinetic constrictions" were conspicuous features, a bisatellited fragment formed by the fusion of satellited fragments of two chromosomes being especially striking. Increases in chromosome length and changes in chromosome form could be specifically related to the fusion of "distal fragments" which lacked insertion regions with other chromosomes which possessed them. Navashin (33, 34) has, also, reported the finding of similar alterations in roots of plants grown from aged seed.

In *Nicotiana Tabacum*, heavy X-ray or radium treatment of sex cells, seeds, or the growing points of seedlings produces an extreme degree of fragmentation (Fig. 2) and a certain amount of fusion, accompanied by aberrations in the spindle mechanism. The cytological evidence

represent points of functional fiber attachments, no final evidence as to the possibility of a de novo origin of an insertion region was provided. In addition to fragmentation, the shortened condition of one chromosome and the elongation of another, in *Vicia* and *Crepis*, was interpreted in terms of translocation. The "association" of two chromosomes and the translocation of fragments from

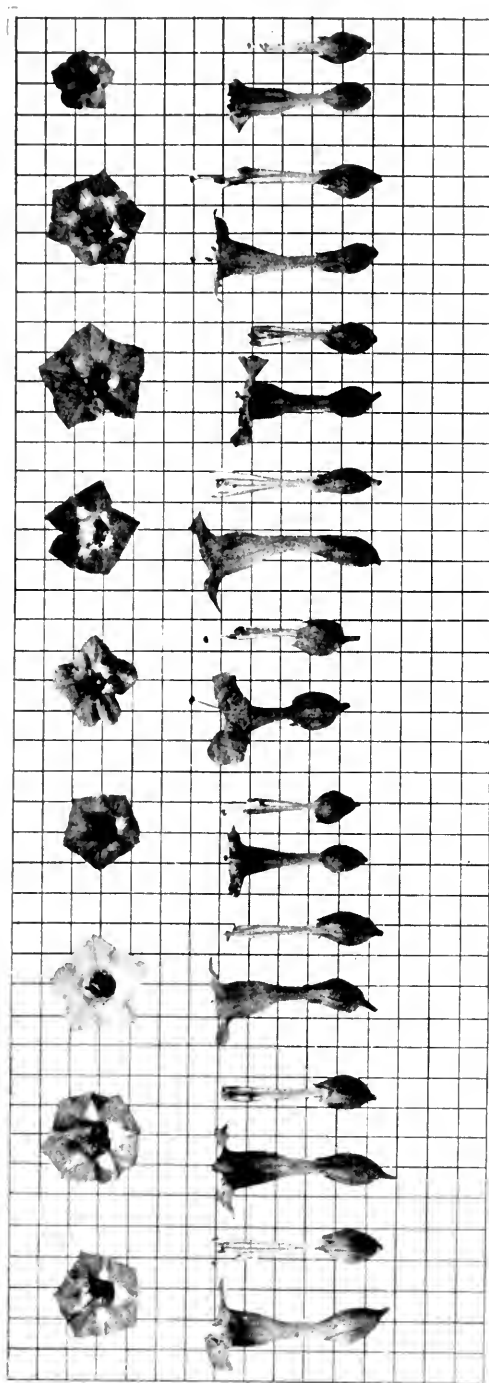

FIG. 3.—Extent of variation in first generation in X-raying of buds of *N. Tabacum* var. *purpurea* two days after anthesis, as illustrated by distinction from control (extreme left) in flower size, color, shape and insertion of parts. PMC of buds on the same parent plant at the time of X-raying were in meiosis and the extent of chromosomal alteration induced in them is shown in Fig. 2.

shows such extreme and apparently complete disruption of chromosomal mechanisms in mitosis and meiosis that gametic or zygotic lethality leading to complete sterility might be anticipated. This was, in general, the result obtained, but in some cases a small amount of seed was produced, giving progenies which in external morphology, genetic behavior, and chromosomal constitution (Goodspeed, 13b) showed the extent to which nuclear alteration in this species can go without consequent inviability. Thus, in one instance in which the chromosomes of PMC were seen to have been very severely disrupted following heavy X-ray

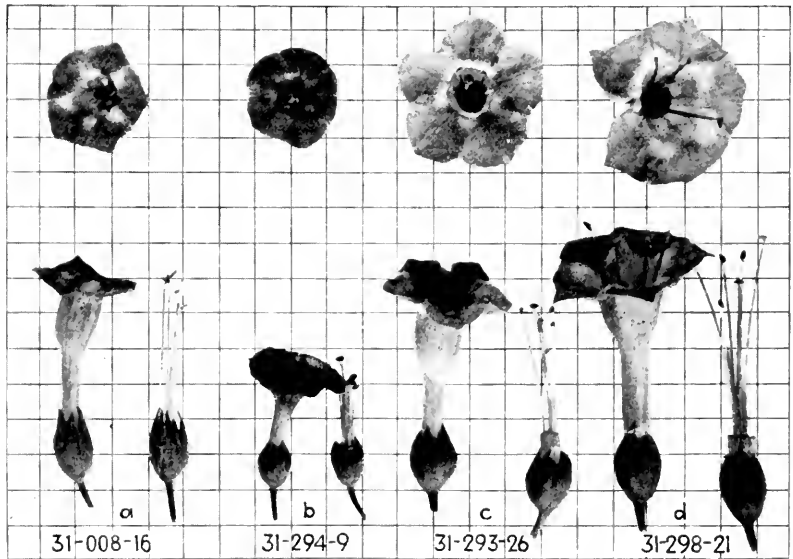

FIG. 4.—Flowers of *N. Tabacum* var. *purpurea*. (a) Control, (b), (c), and (d), types obtained in third generation after X-radiation from a "normal" in the first generation progeny, the extent of variation in which is shown in Fig. 3.

dosage (Fig. 2), a small set of viable seed was obtained on self-pollination and in a progeny of 48 plants grown from it (Table 1, fourth case), only two approximated the control while many showed extreme variations in all vegetative and floral characters. Figure 3 gives evidence of the alterations in flower size, form, and color, which occurred. A progeny grown from one of the two plants apparently normal in external morphology again showed a large range of variants and from certain of these it has been possible to establish distinct derivative types (Fig. 4b, c). In other plant species, also, a similar amount of variation following irradiation has been observed and undoubtedly is in large part a reflection of various sorts of induced chromosomal alteration (cf. Lindstrom, 28; McKay and Goodspeed, 31; Horlacher and Killough, 22).

Table 1 contains some, largely unpublished, results indicating the extent of variation in X_1^2 induced in *N. Tabacum*. The cytological and genetic evidence available indicates that the majority of the striking variations from control in external morphology were the reflections of induced chromosomal alterations of the types referred to. In other words, the data submitted in this table illustrate the frequency of induced chromosomal alteration in this species.

TABLE 1.—VARIATION IN THE FIRST GENERATION FROM X-RADIATION OF SEX CELLS, SEEDS, AND SEEDLINGS OF *NICOTIANA TABACUM* VAR. *PURPUREA*
Dosage in each case 50 kv. and 5 ma. at 30 cm., no filter

Tissue	Age, condition	Exposure, min.	Variant	Normal	Total	Variant, per cent
EMC	36 hr. before anthesis	45	11	92	103	11
EMC	1-2 hr. before anthesis	45	75	67	142	53
EMC	1 day after anthesis	45	6	88	94	6
Zygote	2 days after anthesis	45	46	2	48	90
Zygote	5 days after anthesis	45	35	14	49	70
Zygote	7 days after anthesis	45	13	...	13	100
Total.....			186	263	449	41
Mature pollen	Complete pollination	30	8	138	146	6
Mature pollen	Complete pollination	45	45	104	149	30
Mature pollen	Controlled pollination	45	93	42	135	70
Total.....			146	284	430	34
Seeds	Dry	45	13	83	96	13
Seeds	Dry	75	44	99	143	31
Seeds	Dry	110	30	62	92	33
Seeds	Dry	180	17	29	46	37
Total.....			104	273	377	28
Seeds	Soaked	10-20	40	106	146	28
Seeds	Soaked	25-30	41	110	151	27
Seeds	Soaked	45-60	42	126	168	25
Seeds	Soaked	100	34	62	96	35
Seeds	Soaked	120	22	...	22	100
Total.....			179	404	583	31
Seedlings	18 days old	25	10	42	52	20
Seedlings	20 days old	10	23	70	93	25
Seedlings	20 days old	20	23	53	76	30
Seedlings	20 days old	30	18	47	65	28
Seedlings	26 days old	30	70	27	97	72
Total.....			144	239	383	38
Total for all tissues, conditions, and exposures....			759	1463	2222	34

Doubtless the extent to which chromosomal alteration can occur in *Nicotiana Tabacum* without lethality, as shown in Table 1 and as indicated by extensive cytogenetic evidence, is in part a product of its

² The designations X_1 , X_2 , etc., and R_1 , R_2 , etc., refer to the successive generations derived from X-ray or radium treatment of reproductive or meristematic tissues.

polyploid origin—a type of origin undoubtedly characteristic of many angiosperms. Stadler (40a, 44) has discussed the relation of polyploidy to mutation and points out the apparent reduction in induced-mutation frequency and in the frequency of induced partial sterility with an increasing degree of polyploidy in *Triticum*. On the other hand, just as in *N. Tabacum*, the polyploid character of *T. vulgare* permits the production of a large number of chromosomal mutants in the first generation following irradiation (Sapéhin, 37). In the same generation many such types are produced in *Datura* following radium treatment. Thus, of 400 plants, 196 were distinctly abnormal in external morphology (Blakeslee, *et al.*, 6). While all the variants listed in Table 1 are taken to be reflections of induced chromosomal abnormalities, the total number of such alterations in the progenies listed is greater since plants normal in external morphology may, also, possess quantitative changes in the chromosome complement (cf. Bergner, Satina, and Blakeslee, 2).

In what follows, additional evidence as to induced chromosomal alterations in plants is reviewed in terms of the categories referred to above (page 1281).

In *Nicotiana*, 2 tetraploids, 3 triploids, and 11 haploids have appeared in progenies derived from X-radiation or radium treatment of seeds, the growing points of seedlings, or sex cells. Two haploids, one of *Tabacum* var. *purpurea* from X-raying of embryos and of one of *glutinosa* (cf. Goodspeed and Avery, 17) from X-raying of seeds, occurred in X_1 , while the remainder were found in later generations. Two haploids of *glutinosa* appeared in X_3 from partially fertile, variant X_2 plants. Of 6 other *Tabacum* var. *purpurea* haploids, 2 which occurred in X_3 and X_4 did not differ significantly from control haploids, while 4 appeared in X_3 to X_6 progenies of stable derivative types and exhibited their morphological distinctions from control. A haploid plant was, also, found in an X_2 progeny of *N. Tabacum* var. Connecticut Broadleaf. The occurrence of none of these haploids, and certainly not those which appeared in X_1 after irradiation of embryos or seeds, can be assigned directly to effects of irradiation. In generations after X_1 it does, however, appear probable that secondary effects of treatment have played a part in the production of such an apparently high percentage of haploid plants. Thus, the presence of a considerable to a high degree of pollen sterility in the derivative lines may be related to parthenogenetic development of unfertilized eggs under the stimulus of pollen-tube growth and a certain proportion of successful fertilizations. An analogous explanation is given for the origin of haploid plants in F_1 interspecific hybrids.³

³ In *N. glutinosa* the only haploids known have appeared in the progenies above referred to. Stadler (43) found a somewhat similar situation in maize, where haploids occurred in cultures of irradiated plants where before they had not been found in untreated lines, but he is likewise doubtful as to the relation of their occurrence to treatment.

In various races derived from X-radiation of *Tabacum* var. *purpurea* there is evidence of occurrence of a considerable number of triploid plants, but only three of them have been checked cytologically. They doubtless owe their origin to the chromosomally unbalanced condition of the parent plants, such unbalance being known to favor the formation of somatic gametes. Two of the recognized triploids appeared in progenies of "deformed" (cf. Goodspeed and Avery, 19), in which it was found that abnormal meiotic behavior resulting from induced chromosomal alteration gave rise to such gametes. The third, apparently, came from an induced trisomic (Goodspeed, 13a). A vigorous basal lateral of a highly abnormal, small, weak X_1 plant of *Tabacum* var. Maryland Mammoth proved to be tetraploid (Goodspeed, 13a) and, thus, had its origin in a tetraploid cell lineage in that sector of the stem from which the shoot arose. Stein (45, *et seq.*) has shown that polyploid nuclei are found in all tissues of *Antirrhinum* plants possessing the induced, genotypically determined "phytocarcinome complex" and also in certain cell layers of chimeral plants obtained by radium treatment of seed. The tetraploid shoot, above referred to, doubtless was a by-product of treatment through the effects on somatogenesis of the chromosomal alterations initially induced, since such shoots have not been reported as occurring on untreated plants. However, tetraploid cells and sectors are to be found not infrequently in root tips of untreated *Nicotiana* species and probably they occur in the stem also. Again, a tetraploid branch on a normal plant would readily escape detection, whereas in this case it was conspicuous because of its greater vigor as compared with other branches of the weak, variant plant. A second tetraploid occurred in an X_5 culture of *N. sylvestris*, from the cross of a plant heterozygous for a recessive "bunchy" type with the dominant control. That this tetraploid arose from a suspended early zygote mitosis rather than through union of somatic gametes was shown by the fact that the progeny exhibited the tetraploid segregation ratio for "bunchy"—one tetraploid "bunchy" in 36 plants. The occurrence of this *sylvestris* tetraploid is thus not to be related to primary or secondary effects of irradiation. Stadler (43) reports no tetraploids in 1000 plants, or 600 selfed progenies, of maize. Randolph (36), on the other hand, has secured a large number of polyploids by heat treatment of zygotes and proembryos of maize.

The available evidence, just described, indicates that irradiation in its primary effects is not a source of the haploid or polyploid condition in higher plants. On the other hand, secondary effects based upon initial chromosomal alterations may be expected to induce production of somatic gametes, tetraploidy, and possibly also the proliferation of the egg to give haploidy.

It is clear that high-frequency radiations, through their primary or secondary effects, increase the normal incidence of both nonconjunction

and nondisjunction, the sources of polysomics and monosomics. After heavy dosages, complex chromosomal reorganizations, in *Nicotiana Tabacum* at least, often accompany these processes so that their results cannot be recognized. On the other hand, to them may be ascribed a larger role than they actually play. Thus, Mavor (29), in *Drosophila*, assigned all exceptional offspring of X-rayed females to nondisjunction of the X-chromosome, whereas other factors were undoubtedly responsible for certain of the eliminations of this chromosome. Again, the plants of the X_1 *N. Tabacum* progeny, above referred to (page 1286, Fig. 3), and 90 per cent of which were strikingly altered in external morphology in contrast to control, possessed chromosome complements so thoroughly disrupted and reorganized that the effects of nondisjunction or non-conjunction could not be followed. In other cases, however, simple monosomic or trisomic individuals were found in X_1 cultures. Some appeared as the only variants in progenies otherwise equivalent to control, while others occurred along with a considerable proportion of altered sister plants. It is to be noted that in *N. Tabacum*, monosomics and trisomics in X_1 have followed X-ray or radium treatment not only of buds in meiotic stages but also of mature pollen and dry or soaked seeds.

Gager and Blakeslee (10) found 17.7 per cent of chromosomal variants in the immediate progeny of buds of *Datura* treated with radium, while only 0.47 per cent occurred in untreated cultures. Most of the variants were simple trisomic types, but some were secondaries, and others such compound chromosomal types as Nubbin (Blakeslee, 4, 5). Delauney (9) found that the majority of the variant wheat plants from ears subjected to X-radiation were chromosomal mutants. In half the cases he reports fragmentation as well as addition or subtraction of chromosomes was involved. In X_1 and R_1 progenies of *N. Tabacum* a far higher proportion of monosomics and trisomics occur than in untreated populations. Only a few have been examined cytologically or genetically. Sixteen monosomics and 8 trisomics in X_1 have been checked by both methods and found to be simple chromosomal types, and 8 other X_1 variants have genetically been shown to belong to one or another category. Trisomics have also been obtained in X_1 progenies of *N. sylvestris* and *N. Langsdorffii*.

The X_1 monosomic and trisomic derivatives in *Nicotiana Tabacum* owe their occurrence to primary effects of high-frequency radiation. Such types may also arise in plants as by-products of treatment—secondary effects. The latter include (a) induced mutations (possibly extragenic) affecting chromosome conjugation, and (b) induced chromosomal reorganizations such as translocation, attachment, etc. An illustration of the first class of secondary effects is furnished by, largely unpublished, evidence as to an induced asynaptic condition in *N. sylvestris* (Goodspeed,

16) which appeared in an X_2 plant and has been investigated through X_6 . All derivative lines have proved to be genetically asynaptic, although great variation is shown in the amount of pairing in different plants, at different stages of maturity of the same plant and under different environmental conditions. Although no monosomic types have appeared, a large number of polysomies have been found. Ten of the distinct trisomic types are undoubtedly "primaries" and among other trisomies which have occurred the remaining two will doubtless be identified. In addition, a number of double trisomies and four tetrasomies have been recognized. An illustration of the other type of secondary effect producing aneuploidy is provided by the case of the "deformed" X-ray derivative of *N. Tabacum* which is referred to in what follows.

As already pointed out, chromosome fusions, whether preceded or followed by fragmentation, are characteristic products of irradiation in plants. Thus, Lewitsky and Araratian (26) describe and illustrate an induced association of two homologous and of two nonhomologous chromosomes in *Crepis capillaris*. An instance of attachment involving two homologous chromosomes is provided by the *N. Tabacum* X-ray derivative "deformed" (cf. Goodspeed and Avery, 19). Reference has already been made to the "sticky" character often visibly assumed by chromosomes following irradiation, and it is postulated that such initial alteration is responsible for the more or less permanent chromosomal attachment involved in the origin of "deformed." A "deformed" plant exhibits tissue abnormalities and mosaicism as a result of elimination in certain cell lines of attached chromosomes. Its progeny consists of "deformed" plants together with monosomies, trisomies, tetrasomies, and simple and complex products of chromosomal reorganization, certain of the latter being related to breakages of the original chromosomal attachment. Similar attachments involving the major portions of two chromosomes and resulting in the production of chromosomes possessing two insertion regions have been shown by McClintock (30) to be products of translocation induced in maize by X-radiation. Such abnormally constituted chromosomes are assumed to be direct products of translocation and, also, to occur as a result of crossing over between the translocated chromosome and one of its normal homologs.

As already noted, fragmentation is certainly the most conspicuous and probably the most typical chromosomal alteration produced in plants by high-frequency radiation. With the rather meager evidence available it is not, however, clear whether chromosomal breakage generally follows, precedes, or is necessarily accompanied by fusion or attachment of chromosomes or chromosome segments. Serebrovsky (39) has suggested that breakage following attachment is the significant process, whereas Stadler (44) contends that initial breakage of the

chromosome together with the attachment of the fragments to one another by their broken ends offers adequate explanation of the origin of induced chromosomal reorganization in maize. In general, cytogenetic investigations of effects of high-frequency radiation have tended to emphasize the role of quantitative or extragenic alterations as a cause of what is interpreted as gene mutation. Certain general considerations in this connection have been discussed elsewhere (Goodspeed, 14). Serebrovsky (39) indicates that the type of chromosomal alteration referred to above may be the principal method of origin of gene mutation and Stadler (44) holds that extragenic changes, and chiefly nonlethal deficiencies, are responsible for the majority of induced mutations in plants. Stadler further suggests that reverse mutations, the occurrence of which is taken to be the strongest argument for intragenic origin of mutations, may prove capable of a mechanical interpretation.

The question as to the fate of the fragments initially produced by chromosomal disruption after treatment (cf. Fig. 2) is important. In general, chromosome fragments do not occur in progenies from tissues in the cells of which fragmentation was observed, owing either to the fact that the treatment is lethal for these cells or to the fact that the fragments involved are eliminated because they do not possess insertion regions or homologs. Their survival is favored if they contain genic material essential for viability which is not present elsewhere in the chromosome complement. In any case, it is clear that chromosome fragments do persist and become a permanent feature of the chromosome garnitures of plants in generations far removed from the one immediately resulting from irradiation. For example, in *Datura* (Blakeslee, Bergner, and Avery, 7) a true-breeding compensating type possesses 13 pairs of chromosomes, one of which is a fragment pair.

Evidence as to survival and significance of chromosome fragments in plants is also furnished by certain types which have been derived by X-raying of a single sex cell of *N. Tabacum* (Goodspeed and Avery, 20). The X_1 plant in which these lines originated possessed fragment chromosomes. In later generations 14 distinct derivative types have been obtained, 7 of which are true breeding. Of the latter types, some possess a fragment pair and have maintained such a chromosome constitution for five generations. In certain of the nonestablished types a greater number of fragments occur but are not consistently maintained, owing to the fact that they contain duplicated chromosomal material. Similar behavior is characteristic of the fragment type "Loafoid" in *Datura* (Blakeslee, Bergner, and Avery, 7).

It is obvious that deficiency may be a product of induced chromosomal fragmentation, occurring wherever a fragment lacks an insertion region and does not produce lethality if lost. Such deficiencies are reflected in distinct morphological types when they become established in the

homozygous condition. Thus, in *N. Tabacum*, true-breeding derivatives, distinct morphologically and giving evidence of chromosomal losses, have appeared. Chromosomal reorganizations such as translocation, duplication, deficiency and deletion undoubtedly were concerned in the origin of the *N. Tabacum* derivatives just referred to and also have occurred as secondary products in later generations to have a part in the definition of these types. For example, a type distinct in morphological characters (Fig. 4b) has been derived from a plant normal in external morphology which occurred in the X_1 progeny referred to above (page 1886), in which the majority of the plants were striking variants. When crossed with control, this type shows, at first meiotic metaphase, a ring configuration involving four chromosomes (Fig. 5a).

Such a configuration indicates that portions of two chromosomes have been interchanged. While the interchange may not have been directly concerned in the differentiation of the new morphological characters which distinguish the particular type involved, its occurrence indicates that such chromosomal reorganizations have accompanied this differentiation. Again, in another distinct derivative type (Fig. 4c) of the same X_1 plant,

there are at first metaphase 21 bivalents, 1 trivalent, and 1 fragment pair (Fig. 5b). The presence of the fragment pair and the fact that the monosomic chromosome conjugates with a bivalent show that the chromosomes concerned are products of induced reorganization. In the investigations on chromosomal alteration following irradiation, in *Nicotiana* and in certain other genera, the reorganizations involving sections of chromosomes cannot be so thoroughly analyzed cytogenetically as they can be in *Zea Mays*. Anderson discusses such reorganization in that species in Paper XLII.

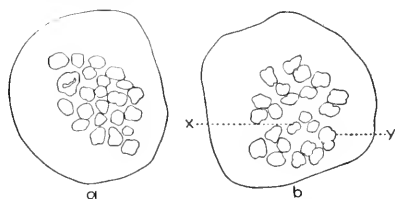

FIG. 5.—Cytological evidence of induced chromosomal interchange and reorganization in *N. Tabacum* var. *purpurea*. (a) Ring of four chromosomes at first meiotic metaphase in F_1 of type shown in Fig. 4b, crossed with control. (b) First meiotic metaphase in type shown in Fig. 4c: 21 bivalents, 1 fragment pair (x), and 1 trivalent (y).

REFERENCES

1. BELLING, J. Crossing over and gene rearrangement in flowering plants. *Genetics* **18**: 388-413. 1933.
2. BERGNER, A. D., S. SATINA, and A. F. BLAKESLEE. Radium experiments with *Datura*. III. (Abst.) *Anat. Rec.* **41**: 99. 1928.
3. BERGNER, A. D., S. SATINA, and A. F. BLAKESLEE. Prime types in *Datura*. *Proc. Nation. Acad. Sci.* **19**: 103-115. 1933.
4. BLAKESLEE, A. F. The chromosomal constitution of Nubbin, a compound ($2n + 1$) type in *Datura*. *Proc. Nation. Acad. Sci.* **13**: 79-85. 1927.
5. BLAKESLEE, A. F. Nubbin, a compound chromosomal type in *Datura*. *Ann. New York Acad. Sci.* **30**: 1-29. 1927.
6. BLAKESLEE, A. F., S. SATINA, A. D. BERGNER, J. S. POTTER, and A. G. AVERY. F_1 's from radium treated pollen. (Abst.) *Anat. Rec.* **47**: 383. 1930.

7. BLAKESLEE, A. F., A. D. BERGNER, and A. G. AVERY. Methods of synthesizing pure-breeding types with predicted characters in the Jimson weed, *Datura Stramonium*. *Proc. Nation. Acad. Sci.* **19**: 115-122. 1933.
8. BRIDGES, C. B. Aberrations in chromosomal materials. *Eugenics, Genetics and the Family* **1**: 76-81. 1923.
9. DELAUNAY, L. Die Chromosomenaberranten in der Nachkommenschaft von röntgenisierten Ähren einer reinen Linie von *Triticum vulgare albidum*. *Zeitsch. Indukt. Abstamm. und Vererbungsleh.* **55**: 352-355. 1930.
10. GAGER, C. S., and A. F. BLAKESLEE. Chromosome and gene mutations in *Datura* following exposure to radium rays. *Proc. Nation. Acad. Sci.* **13**: 75-79. 1927.
11. GOODSPEED, T. H. Cytological and other features of variant plants produced from X-rayed sex cells of *Nicotiana tabacum*. *Botan. Gaz.* **87**: 563-583. 1929.
12. GOODSPEED, T. H. The effects of x-rays and radium on species of the genus *Nicotiana*. *Jour. Heredity* **20**: 243-259. 1929.
13. GOODSPEED, T. H. Inheritance in *Nicotiana tabacum*. IX. *Univ. California Publ. Bot.* **11**: 285-298. 1930. [See also *Ibid.* (a) **11**: 299-308, (b) 309-318. 1930.]
14. GOODSPEED, T. H. Die Bedeutung von quantitativen Chromosomenveränderungen. *Naturwiss.* **23**: 476-483. 1931.
15. GOODSPEED, T. H. Cytogenetic consequences of treatment of *Nicotiana* species with x-rays and radium. *Svensk Bot. Tidskr.* **26**: 147-162. 1932.
16. GOODSPEED, T. H. Chromosome unbalance and the asynaptic condition as induced in *Nicotiana* by X-radiation. *Proc. Sixth Internat. Congress Genetics* **2**: 67-69. 1932.
17. GOODSPEED, T. H., and P. AVERY. The occurrence of a *Nicotiana glutinosa* haplont. *Proc. Nation. Acad. Sci.* **15**: 502-504. 1929.
18. GOODSPEED, T. H., and P. AVERY. Nature and significance of structural chromosome alterations induced by X-rays and radium. *Cytologia* **1**: 308-327. 1930.
19. GOODSPEED, T. H., and P. AVERY. Inheritance in *Nicotiana tabacum*. XIII. *Genetics* **18**: 487-522. 1933.
20. GOODSPEED, T. H., and P. AVERY. The cytogenetics of 14 types derived from a single X-rayed sex cell of *Nicotiana Tabacum*. *Jour. Genetics [London]* **29**: 327-353. 1934.
21. GOODSPEED, T. H., and A. R. OLSON. The production of variation in *Nicotiana* species by X-ray treatment of sex cells. *Proc. Nation. Acad. Sci.* **14**: 66-69. 1928.
22. HORLACHER, W. R., and D. T. KILLOUGH. Radiation-induced variation in cotton. *Jour. Heredity* **22**: 253-262. 1931.
23. HORLACHER, W. R., and D. T. KILLOUGH. Chlorophyll deficiencies induced in cotton (*Gossypium hirsutum*) by radiations. *Trans. Texas Acad. Sci.* **15**: 33-38. 1932.
24. KOERNICKE, M. Über die Wirkung von Röntgen und Radiumstrahlen auf pflanzliche Gewebe und Zellen. *Ber. Deut. Bot. Ges.* **23**: 404-415. 1905.
25. LEVINE, M. Cytological studies on irradiated tissues. I. *Proc. Internat. Cong. Plant Sciences Ithaca* **1**: 271-297. 1926. (Bibliography.)
26. LEWITSKY, G. A., and A. G. ARARATIAN. Transformations of chromosomes under the influence of x-rays. *Bull. Appl. Bot. and Plant Breeding* **27**(1): 265-303. 1931.
27. LEWITSKY, G. A., A. ARARATIAN, J. MARDJANISHVIL, and H. SHEPELEVA. Experimentally induced alterations of the morphology of chromosomes. *Amer. Naturalist* **65**: 564-567. 1931.

28. LINDSTROM, E. W. Hereditary radium-induced variations in the tomato. *Jour. Heredity* **4**: 128-137. 1933.
29. MAVOR, J. W. The production of non-disjunction by X-rays. *Science* **55**: 295-297. 1922.
30. McCCLINTOCK, B. Cytological observations of deficiencies involving known genes, translocations and an inversion in *Zea mays*. *Missouri Agr. Exp. Sta. Res. Bull.* 163. 1931.
31. McKAY, J. W., and T. H. GOODSPEED. The effects of X-radiation on cotton. *Science* **71**: 644. 1930.
32. NAVASHIN, M. A preliminary report on some chromosome alterations by X-rays in *Crepis*. *Amer. Naturalist* **65**: 243-252. 1931.
33. NAVASHIN, M. Origin of spontaneous mutations. *Nature [London]* **131**: 436. 1933.
34. NAVASHIN, M. Altern der Samen als Ursache der Chromosomenmutationen. *Planta* **20**: 233-243. 1933.
35. PEKAREK, J. Über den Einfluss der Röntgenstrahlen auf die Kern- und Zellteilung bei Wurzelspitzen von *Vicia faba*. *Planta* **4**: 299-357. 1927. (Bibliography.)
36. RANDOLPH, F. Some effects of high temperature on polyploidy and other variations in maize. *Proc. Nation. Acad. Sci.* **18**: 222-230. 1932.
37. SAPÉHIN, A. A. Röntgenmutationen beim Weizen. *Züchter* **2**: 257-259. 1930.
38. SCOTT, G. H. The disposition of the fixed mineral salts during mitosis. *Bull. Histol. Appl. Phys. et Path.* **7**: 251-257. 1930.
39. SEREBROVSKY, A. S. A general scheme for the origin of mutations. *Amer. Naturalist* **63**: 374-378. 1929.
40. STADLER, L. J. Genetic effects of X-rays in maize. *Proc. Nation. Acad. Sci.* **14**: 69-75. 1928. [See also *Ibid.* (a) **15**: 876-881. 1929.]
41. STADLER, L. J. The rate of induced mutation in relation to dormancy, temperature and dosage. (*Abst.*) *Anat. Rec.* **41**: 97. 1928.
42. STADLER, L. J. Some genetic effects of X-rays in plants. *Jour. Heredity* **21**: 3-19. 1930.
43. STADLER, L. J. The experimental modification of heredity in crop plants I, II. *Sci. Agric.* **11**: 557-572, (a) 645-661. 1931.
44. STADLER, L. J. On the genetic nature of induced mutations in plants. *Proc. Sixth Int. Cong. Genetics* **1**: 274-294. 1932.
45. STEIN, E. Über den Einfluss von Radiumbestrahlung auf *Antirrhinum*. *Zeitsch. Indukt. Abstamm. und Vererbungsl.* **29**: 1-15. 1922. [See also *Ibid.* (a) **43**: 1-87. 1926; (b) **62**: 1-13. 1932; (c) **64**: 77-94. 1933.]
46. STEIN, E. Über experimentelle Umstimmung der Reaktionsnorm bei *Antirrhinum*. *Biol. Zentrabl.* **47**: 705-722. 1927. [See also *Ibid.* (a) **49**: 112-126. 1929; (b) **50**: 129-158. 1930.]
47. STEIN, E. Über den durch Radiumbestrahlung von Embryonen erzeugten erblichen Krankheitskomplex der *Phytocarcinome* von *Antirrhinum majus*. *Phytopath. Zeitsch.* **4**: 523-538. 1932.
48. STUBBE, H. Untersuchungen über experimentelle Auslösung von Mutationen bei *Antirrhinum majus*. IV. *Zeitsch. Indukt. Abstamm. und Vererbungsl.* **64**: 181-284. 1933.
49. TIMOFÉEFF-RESSOVSKY, N. W. Die bisherigen Ergebnisse der Strahlengenetik. *Erg. Med. Strahlenforschung* **5**: 131-227. 1931. (Bibliography.)
50. YAMAMOTO, Y. The influence of X-ray on the germ cells of *Rumex acetosa* L. *Kwagaku* **2**: 458-462. 1932.



XLII

INDUCED CHROMOSOMAL ALTERATIONS IN MAIZE

E. G. ANDERSON

William G. Kerekhoff Laboratories of the Biological Sciences, California Institute of Technology, Pasadena, California

The normal chromosomes. Inversions. Deficiencies. Interchanges. Nature of the alterations produced by irradiation. References.

THE NORMAL CHROMOSOMES

The great majority of varieties of maize grown in the United States appear to be uniform in the arrangement of material in the chromosomes. This arrangement we accept as the normal. The 10 normal chromosomes of maize are figured diagrammatically by McClintock (32, page 192). Different varieties or strains present such visible differences as presence or absence of given knobs or differences in size, shape, or appearance of given chromomeres and knobs. Two types of satellite on chromosome 6 have also been described (McClintock, 33).

In addition to the normal diploid set of 10 pairs of chromosomes, there may be present in some strains, one or more *B*-type chromosomes (Randolph, 36, McClintock, 32). These are an aberrant type of chromosome, behaving somewhat less regularly at meiosis and having no apparent function in inheritance.

The 10 normal chromosomes ordinarily synapse regularly at meiosis, but infrequently some portions of the chromosomes may appear paired nonhomologously. Such nonhomologous pairing, although rare in normal diploids, is frequent in many cases of unbalanced or altered chromosomes (Burnham, 15 and 16, McClintock, 32). A thorough study of non-homologous pairing has been made by McClintock (32).

Randolph (38, 39) has reported tetraploids induced by temperature treatments. Losses of a chromosome induced by X-rays have been detected cytologically (Randolph, 37). Some of the induced gene deficiencies detected by endosperm characters (Stadler 48, 50, 52) are probably whole chromosome eliminations. Increases or decreases in chromosome number will not be treated further except to be included in the bibliography.

INVERSIONS

In a few of the strains of maize which have been studied cytologically, a portion of a chromosome appears in a reversed order. These cases

are listed as inversions or inverted sections, though nothing is known of their origin. One such inversion in the short arm of chromosome 8 (McClintock, 32) is present in a number of the strains used in genetic studies. A short inversion in chromosome 4 including the spindle attachment has also been described by McClintock (32). It causes an apparent displacement of the position of the spindle attachment. A similar displacement in chromosome 2 is sometimes observed and is probably due to a similar inversion.

From X-ray treatment, McClintock (30, 32) has described an inversion in chromosome 2. Approximately two-thirds of the chromosome became inverted. A similar inversion involving a still greater portion of chromosome 2 has been found, also from X-ray treatment (Muntzing and Anderson, unpublished).

The longer inversions, when heterozygous, give typical inversion loop configurations at meiosis (see McClintock, 30, Figs. 20-28, or Sharp, 46, pages 315-318). Such figures are formed by the synapsis of homologous portions in all parts of the chromosome. In short inversions, loop configurations are seldom formed. Instead the inverted sections are paired nonhomologously or else remain unsynapsed (McClintock, 32). Homozygous inversions show normal synapsis.

In the cases of long inversions considerable amounts of pollen and egg sterility are found. This is due to crossing over taking place within the inversion loop. When homozygous, fertility is normal. No studies have yet appeared on the linkage relations in maize inversions, but the linkage studies on *Drosophila* inversions together with McClintock's work on nonhomologous pairing may serve as a basis for expectations. Homozygous inversions should give normal linkage behavior, but with the genes in different serial order. Heterozygous short inversions which seldom show loop configurations, but do show nonhomologous pairing, may show only a reduction or virtual elimination of crossing over in the inverted section with no accompanying pollen or egg sterility. No data are at hand to indicate if reduced crossing over beyond the limits of the inversion is to be expected. Reduction of crossing over outside of the limits of inversion occurs in *Drosophila*, but the cytological behavior at meiosis is unknown. The best known of the *Drosophila* cases presumably form loop configurations, since viable double cross-overs have been found within the inverted sections.

Heterozygous long inversions which consistently form loop configurations should show partial pollen and egg sterility accompanied by a reduction of observed crossing over due to elimination of most of the cross-overs within the inversion loop. Except for rare cases where unbalanced or deficient chromosomes may be viable, all single cross-overs within the loop must be inviable. Crossing over may be further reduced without additional sterility by nonhomologous pairing, incom-

plete synapsis or other causes. There is need at the present time for adequate linkage studies on inversions of known cytological behavior.

The inversions found in our genetic stocks were picked up during the course of cytological examinations for other purposes. The inversion in chromosome 2 from X-ray treatment (McClintock 30, 32) was similarly discovered in the course of cytological examination of a deficiency in another chromosome. The unpublished long inversion in chromosome 2 (Muntzing and Anderson) was detected by means of partial pollen sterility. No data are available to indicate the frequency of occurrence of inversions following irradiation, but it is probably high. The only ones readily discovered are the long inversions which may be detected and followed by means of the partial sterility of pollen.

DEFICIENCIES

1. *Terminal Deficiencies.*—These consist of the loss of an end of a chromosome. Several cases have been described by Stadler (50) and McClintock (30). These were found after X-ray treatment and were not transmitted to the following generation. In each case the zygotes deficient for a portion of a chromosome were viable and vigorous, but the spores with a deficient haploid complement did not survive to function. These deficiencies were found by placing pollen carrying dominant genes on silks of the appropriate recessives and irradiating during the growth of the pollen tubes. Plants deficient for a dominant gene were examined cytologically at meiosis. A portion of one chromosome was missing. The deficient chromosome paired normally with the homologous portions of the corresponding normal. Beyond the end of the deficient chromosome, the normal chromosome appeared as a single unpaired thread. By the identification of the chromosome involved and by measurement of the region deficient, it was possible to assign certain genes to definitely limited regions of particular chromosomes.

More cases of terminal deficiency from X-rays have been described by McClintock (32), Stadler (53), and Creighton (21). Several of these cases are of especial interest. Stadler's (53) study of a deficiency for the gene *R* showed the absence of the terminal one-fifth of the long arm of chromosome 10. Deficient microspores gave rise to small-sized immature-looking pollen grains which were unable to function. Eggs carrying the deficiency functioned about one-third as frequently as the normal. Plants heterozygous for the deficiency were less vigorous and a little later maturing than normal plants.

Creighton (21) has described three deficiencies for *yg₂* at or near the end of the short arm of chromosome 9. One of these (*Df* 9-1) was deficient for about one-fourth of the arm including the conspicuous terminal knob. The absence of the knob is cited as proof that the deficiency is really a terminal one.

Some data on the frequency of induced deficiency of known endosperm genes have been presented by Stadler (50, 53). Endosperm characters were selected for these quantitative studies because large numbers are more readily obtained, compensating for the disadvantage that they cannot be checked cytologically. The induced deficiencies are roughly in proportion to the X-ray dosage given. But for a given dosage each gene has a different characteristic frequency. Of the genes studied, *A* became lost most frequently and *Y* least frequently. The most instructive are the data involving *C Sh* and *Wx*. These are all in the short arm of chromosome 9 with *Wx* known to be closest to the spindle-fiber insertion. The linkage order is *C Sh Wx*, with about 4 per cent crossing over between *C* and *Sh* and about 22 per cent between *Sh* and *Wx*. Of the seeds deficient for *C*, the majority were deficient also for *Sh* and *Wx*. About 25 or 30 per cent were deficient for *Sh* but not for *Wx*. A few were deficient for *C* only. Most of the deficiencies were considered terminal ones. Some of those deficient for all the genes were probably losses of the entire chromosome.

An interesting feature of endosperm deficiencies is the frequent appearance of one or more small islands of cells carrying the dominant genes (Stadler 49, 50). These Stadler interprets as due to recovery of a chromosome affected by X-ray. On this interpretation the deficiency is due to loss of the power of reproduction of the affected chromosome or section of chromosome. At each succeeding mitosis this chromosome goes to one daughter cell or the other. If later it recovers its power of reproduction, it then may divide regularly and form an island of normal (nondeficient) tissue. Since later cytological studies on deficiencies have shown them to be actual losses rather than inactivations, a modification of Stadler's hypothesis seems required. We may assume for whole chromosome losses, that the missing chromosome remains free in the common cytoplasm of the early endosperm, while the nuclei divide for several successive generations, and then becomes incorporated in one of the free nuclei and divides regularly thereafter. Several separate spots, usually clustered as they are, might be formed, for instance, by one or more sporadic divisions of the free chromosome, before being associated with a nucleus. Recovery of a fragment would require that the fragment become attached to one of the chromosomes or, less probably, develop its own spindle fiber. Such things might happen in the endosperm where they would not in ordinary tissue, since there are a number of divisions of the endosperm nucleus in a common cytoplasm followed by migration to the periphery before cell-wall formation takes place. The one case cited by Stadler (49) as recovery in the sporophyte is open to interpretation as an ordinary chimaera in which only a small portion was nondeficient. Similar islands of green tissue are occasionally found in maternally inherited plastid chimaeras.

2. *Internal Deficiencies*.—These consist of the loss of a section of a chromosome not including an end. A very clear case (*Df* 9-2) has been described by Creighton (21), in which the distal one-third of the short arm of chromosome 9 was lost, but the conspicuous terminal knob was retained. The deficiency involved the normal allelomorph of yg_2 . The plant yielded no progeny. Another plant (*Df* 9-3), lacking the normal allelomorph of yg_2 , appeared only to have the terminal knob slightly reduced in size. The plant was fully fertile. It was interpreted as a very short internal deficiency including the base of the knob, but another interpretation, that of mutation, is not excluded. McClintock (30, 32) has described cytologically some further cases of internal deficiency. The observed prophase figures usually involve a loop or foldback in the one chromosome, or else a large amount of asynapsis. The prevalence of nonhomologous pairing under these conditions makes the chromosome configurations very irregular and difficult to interpret.

3. *Ring Chromosomes*.—A number of cases have been described by McClintock (30, 31, 32) of ring-shaped chromosomes or parts of chromosomes. These consist of the middle portion of a chromosome with the spindle attachment. Both ends have become eliminated and the ends of the internal fragment united to form a closed ring. The cases studied vary in size from large rings consisting of nearly the entire chromosome to very small rings consisting of a very short section about the spindle attachment. The type of meiosis pairing with a normal homolog is very variable, usually involving much nonhomologous pairing. (McClintock, 32). Large rings usually pair in whole or in part with the normal chromosome. Small rings are more often completely separate from the normal chromosome, appearing usually as a collapsed ring. The rings do not remain constant in size but may become diminished or enlarged during ordinary mitotic divisions. Occasionally groups of cells are found with conspicuously smaller or sometimes larger rings. That these changes involve eliminations or duplications of portions of the ring is shown especially clearly in a large ring of chromosome 2 (McClintock, 31) which included a conspicuous knob. This knob was missing in many of the smaller sized rings. More rarely it was duplicated in large-sized rings. Where the rings carry a dominant gene and the normal chromosome the recessive allelomorph, eliminations of the section of the ring carrying this gene give rise to mosaic plants.

The changing of size of the ring is undoubtedly related to the mechanism of mitotic splitting of chromosomes, but the nature of the relationship is not clear. If it were merely that the split was not oriented in the same plane throughout the chromosome, the ring should sometimes be doubled in size but not diminished. Interlocking rings would sometimes be formed and might be torn apart during anaphase separation. From such fragmentation one would expect rod fragments rather than

small rings unless the broken ends have an attraction for each other sufficient to unite them even when they are not closely approximated. Such a view seems highly improbable.

Of the described ring chromosomes two arose spontaneously in plants already carrying altered chromosomes. The balance resulted from X-ray treatment. They were detected by means of the gene deficiencies causing mosaic plants.

INTERCHANGES

Chromosomal interchanges or reciprocal translocations are frequently found after X-ray treatment. The earliest discovered cases in maize were found in untreated lines. These have figured most largely in the literature, but interchanges from X-rays far outnumber those from untreated sources.

The genetics and cytology of chromosomal interchanges in maize have been treated in a series of papers by Brink (6, 7), Brink and Burnham (8), Brink and Cooper (9, 10, 11, 12), Cooper and Brink (20), Burnham (13, 14, 15, 16, 17, 18), McClintock (28, 29, 30, 32, 33), Creighton (21), Creighton and McClintock (22), Rhoades (41, 44), Anderson (1, 2), Anderson and Clokey (3), and Clarke and Anderson (19). Brief reviews will be found by Sharp (46), and Anderson (2). In the latter paper will also be found a catalogue list of all the interchanges described for maize.

In an interchange a fragment of one chromosome is exchanged with a fragment from a nonhomologous chromosome. The two new chromosomes when homozygous behave in no way different from normals. The two pairs of chromosomes involved may differ in appearance from the normals and the corresponding linkage maps consist of differently combined parts of the old maps.

When heterozygous, the interchanged chromosomes synapse at meiosis with homologous parts of the normal chromosomes, giving a cross-shaped synaptic figure. The cross is at the point of interchange. In the more typical cases, there are two long arms on opposite sides of this cross, each with a spindle-fiber insertion, and two shorter arms without spindle-fiber insertions. The two long arms are the main portion of the chromosomes. The shorter arms are the interchanged fragments and the homologous portions of the normal chromosomes. For convenience we may designate the normal chromosomes as 1 and 2, the interchanged ones as 1^2 and 2^1 . Crossing over may take place in any arm of the figure, as between 1 and the main portion of 1^2 or between the interchanged fragment of 1^2 and the corresponding portion of 2. During diplotene and diakinesis the synaptic figure opens out into a ring usually with only the ends of the chromosomes attached. This ring is best observed at diakinesis. The distribution at anaphase is ordinarily

such that the two chromosomes 1 and 1² go to opposite poles. Likewise 2 and 2¹ go to opposite poles. But the distribution of 2 and 2¹ seems to be independent of the distribution of 1 and 1² so that four types of spores are formed in equal numbers. These have the following chromosome constitution:

- 1, 2, normal;
- 1², 2¹, interchange;
- 1, 2¹, and 1², 2, inviable.

The normal and interchange spores are viable and fully functional. The other two types have a portion of one chromosome duplicated, and a portion of the other deficient. They are not functional. Consequently half of the ovules fail to develop and half of the pollen is abortive. The chromosomes may occasionally be distributed irregularly, three going to one pole, and one to the other.

In linkage studies, the interchange may be followed by means of pollen semisterility which behaves in outcrosses like a dominant gene at the locus of the interchange in both chromosome maps.

Of the interchanges described semisterile 1 (Brink, 6), semisterile 3 (Burnham, 13), semisterile 4 (Rhoades, 41, 44) and semisterile 5 (Cooper and Brink, 20) may be taken as fairly typical interchanges. Semisterile 2 (Burnham, 13, 18) shows about 59 per cent of bad pollen. The chromosome distribution is somewhat more irregular. About 7 per cent of the diakinesis figures show a chain instead of a ring of chromosomes.

A low sterile described by Burnham (14) forms chains consistently but never rings. The interchange had taken place in the satellite of chromosome 6. The point of interchange is within one or two chromomeres of the end of the chromosome. The interchanged end of the satellite does not show pairing with the normal satellite. This gives a T-shaped pachytene figure, opening out to form a chain at diakinesis. One of the duplicate-deficient classes of spores lacks only a few chromomeres of having all parts of the chromosomes represented, and forms pollen which is not visibly abnormal.

A more extreme case has been described by Clarke and Anderson (19) in which chains are found in only about one-third of the diakinesis figures, the balance showing two slightly unequal "pairs." Here too the interchange is in the satellite of chromosome 6 and also near the end of chromosome 3.

One interchange from irradiation, involving chromosome 6, divided the reticulate region, which is the attachment to the nucleolus (Anderson, 1). This interchange has been used by McClintock (33) for an intensive study of the function and development of the nucleolus. The nucleolus is shown to be organized by this reticulate region or nucleolar-organizing body. When this body is severed by the interchange each part organizes its own nucleolus during the mitotic telophases.

A small amount of nonhomologous pairing is evident in most of the interchanges. In some there is a large amount (Burnham 15, 16; McClintock, 32). It has not yet been ascertained whether these cases of extensive nonhomologous pairing are due to some other alteration in the chromosome at or near the point of interchange.

The extensive series of interchanges listed by Anderson (2) from irradiation are distributed among the 10 chromosomes approximately in proportion to the relative lengths of the different chromosomes. Not enough data have been reported to show the relative frequency of interchanges in different portions of a chromosome.

NATURE OF THE ALTERATIONS PRODUCED BY IRRADIATION

All of the chromosome alterations produced by irradiation, except terminal deficiencies, involve an interchange of parts between non-homologous regions. Terminal deficiencies imply a break in the chromosome without the broken ends becoming reattached.

There are no data available on the relative frequency of inversions, terminal deficiencies, internal deficiencies, ring chromosomes, and interchanges. Any simple relationship between the frequencies of different alterations would go far toward indicating the nature of the mechanism involved. Perhaps such data are not to be obtained because of the differences in the means of detection. The absence of "simple translocations" in maize seems significant. So far as studied, all alterations involving two chromosomes are reciprocal. All inversions found are internal. No attachments to or by the normal ends of chromosomes have been found. These same normal ends are conspicuously prone to be stuck to other chromosomes in prophase preparations. This stickiness is probably not merely an artefact produced by the reagents used in fixing and staining. The stickiness disappears in the later, more condensed stages. Interchanges occurring near the ends of chromosomes are difficult to detect and to study, except some of those in the satellite of chromosome 6. Of 18 interchanges known for chromosome 6, three are in the satellite itself and do not involve more than a maximum of three chromomeres. Finally, two of the three deficiencies found for *yg*₂ (Creighton, 21) were shown by the terminal knob to be internal. This throws suspicion on the validity of terminal deficiencies.

Crossing over in *Drosophila* has been shown to take place in the double strand stage and only two of the four strands cross over. Rhoades (42, 43) has shown that the same applies to maize. Since interchanges between nonhomologous chromosomes resemble crossing over in other ways, it seems not unreasonable to place it also in a double-strand stage when the conditions are most nearly those surrounding crossing over. We may likewise expect only two of the four strands to become interchanged.

The products of interchange of single strands at a double-strand stage are more complex than those expected for breakage and reunion of whole chromosomes. In the case of a double-strand chromosome looped back upon itself (intrachromosomal interchange), one strand may be interchanged with itself or with its sister strand. If we designate the broken ends in their original order as *ab cd*, *b* and *c* being the ends of the intermediate or loop section, the broken ends may become attached in the two new combinations *ac*, *bd* and *ad*, *bc*. The chromosomes recovered are listed in Table 1. Combinations without spindle attachments or with double spindle attachments become lost. In the duplicate-deficient chromosomes, one end of the chromosome is deficient but is replaced by a duplication of the other end. The internal duplications would be of the constitution *abcbed*.

TABLE 1.—CHROMOSOMES RECOVERED FROM INTRACHROMOSOMAL INTERCHANGE OF STRANDS AT DOUBLE-STRAND STAGE
Original sequence of parts *ab cd*

	Strands interchanged	Combination after reattachment			
		<i>ac</i>	<i>bd</i>	<i>ad</i>	<i>bc</i>
Interchange between arms	Identical	a. Normal		a. Normal	
		b. Internal inversion		b. Ring chromosome (united ends lost)	
	Sister	a. Duplication deficiency		Double spindle attachment United ends lost	
		b. Duplication deficiency			
Interchange within one arm	Identical	a. Normal		a. Normal	
		b. Internal inversion		b. Internal deficiency (ring fragment lost)	
	Sister		Double spindle attachment United ends lost	a. Internal duplication	b. Internal deficiency

In the case of interchange between different chromosomes, the sister strands are equivalent. If each segment with spindle attachment unites with the terminal segment from the nonhomologous chromosome, the four resulting chromosome strands may be designated 1, 1², 2, and 2¹.

At anaphase separation the two pairs of strands may be distributed to the daughter nuclei in either of two ways:

- (a) One nucleus 1 + 2 (normal); the other 1² + 2² (interchange).
- (b) One nucleus 1 + 2¹; the other 1² + 2 (both duplicate-deficient).

If assortment is at random, the two types of distribution should occur equally freely.

If the two segments with spindle attachments unite with each other and likewise the terminal segments, there will be two normal chromosomes, one with double spindle attachment and one with none. The two latter will be lost within a few divisions. The two normal chromosomes may go to the same pole or to opposite poles. The resulting daughter nuclei should eventually be either one nucleus normal, the other deficient for both chromosomes, or one nucleus deficient for chromosome 1, the other for chromosome 2.

In the case of alterations due to irradiation of pollen, there is little, if any, elimination before fertilization. Most of the deficient chromosomes except those with two spindle attachments or none are probably capable of surviving in the zygote. But very few will be capable of surviving the haploid gametophyte generation, unless the deficient region is very small. Interchanges and inversions will survive with varying degrees of pollen and egg sterility. As in general the X-rays have been applied to the sperm nucleus after the last haploid mitosis, the two strands present must become separated at the first cleavage of the embryo. This implies that where alterations are induced by the irradiation the embryo is mosaic. Owing to the type of growth, the large majority of plants with induced alterations will have all of the observed tissue of the same constitution. But mosaic plants should be rather frequent. This checks with the observations. The mosaic endosperm seeds reported by Stadler (48), where part of the endosperm is deficient for *C* while the rest is deficient for *Su*, are strong support for this interpretation.

Inversions and interchanges would not be detected in the plant itself, except by pollen or egg sterility or by linkage relations in the progeny. Duplications would probably not be detected by any technique used in maize. Deficiencies involving certain known genes are readily detected. So far as visible gene characters are concerned, most of the internal deficiencies and all of the duplicate-deficient classes both from intra- and interchromosomal interchanges would be classified as terminal deficiencies. Even cytological characteristics and behavior are not to be relied upon except where long terminal sections are involved or conspicuous knobs or other markers are present. The prevalence of non-homologous pairing in unmatched short sections makes it impossible to rely upon synapsis alone for the detection of small terminal fragments.

The three deficiencies for yg_2 in chromosome 9 reported by Creighton (21) are instructive because of the terminal knob involved. *Df* 9-3 involved no gamete sterility and such a small cytological alteration that its interpretation is open to question. If it is a deficiency, it is not a terminal one. *Df* 9-2 is a clear case of an internal deficiency which would have been classified as terminal but for the presence of the conspicuous terminal knob. *Df* 9-1 lacked the knob entirely as well as about one-fourth of the arm. This is probably the best evidence available for a truly terminal deficiency. But the deficient arm may well end with a short terminal section from another chromosome. Creighton states: "Synapsis of the short arms from the spindle-fiber-insertion regions to the point of deletion was regular in most cases. Sometimes there was a lack of association of the last few chromomeres of the deficient chromosome with their homologues on the standard chromosome." It is also interesting that the plant carrying this deficiency was a mosaic with the greater part normal.

For tests of the hypothesis that the induced alterations are due to interchange between strands at a double-strand stage, the types not otherwise expected should be watched for in plants from irradiated pollen. Stocks with the largest number of conspicuous knobs and other chromosome markers should be selected for irradiation studies. In deficient plants, the ends of all chromosomes should be observed carefully. Mosaic plants are of the greatest interest and the nondeficient as well as the deficient sector should be studied. In endosperm studies mosaics where one sector is deficient for one gene and the other sector deficient for a gene from another chromosome should be watched for carefully.

It is possible, and perhaps even probable, that induced alterations take place with more than random frequency near the extreme ends of chromosomes. If the ends are sticky in the living cell during prophase as they appear to be in fixed preparations, this would tend mechanically to bring the distal portions more frequently in close proximity to other chromosomes. A similar, but perhaps less pronounced increase in alteration frequency might be expected near spindle attachments and knobs. Unfortunately a sufficient number of maize interchanges have not yet been examined cytologically to get a picture of their distribution within the chromosome.

Little can be said as to the nature of the action of X-rays in inducing chromosome alterations. The obvious suggestion is that for adjacent chromosomes the irradiation somehow brings about conditions resembling the conditions normally present only in or surrounding homologous chromosomes during corresponding phases of meiosis. The recent work of Metz (35) on the role of the chromosome sheath is interesting in this connection. Metz suggests "that irradiation serves to disturb the

normal insulating properties of the chromosome sheaths and permits intimate contacts between the chromosomes." He also suggests more specifically that irradiation, by decreasing protoplasmic viscosity, "serves to solate the gelatinous "sheath," permitting chromosomes to come into contact with one another and to interact in such a way as to cause segmental rearrangements and gene mutations."

The present information from induced chromosomal alterations in maize is in accord with the view that irradiation acts in a general way on the chromosomes or their surrounding medium, and that interchange between strands may take place wherever chromosomes happen to lie in contact. On this view the increased frequency of interchange with increase of dosage should be due to intensification of the change in the physical condition of the chromosomes or their surrounding medium; whereas the frequency distribution of interchanges in the chromosome should be merely a probability distribution of contacts between chromosomes at the proper stage of mitosis.

REFERENCES

- This bibliography includes the more important papers dealing with tetraploids, triploids, trisomics and chromosome eliminations as well as chromosome alterations
1. ANDERSON, E. G. A chromosomal interchange in maize involving the attachment to the nucleolus. *Amer. Nat.* **68**: 345-350. 1934.
 2. ANDERSON, E. G. Chromosomal interchanges in maize. *Genetics* **20**: 70-83. 1935.
 3. ANDERSON, E. G. and I. W. CLOKEY. Chromosomes involved in a series of interchanges in maize. *Amer. Nat.* **68**: 440-445. 1934.
 4. BEADLE, G. W. The relation of crossing-over to chromosome association in *Zea-Euchlaena* hybrids. *Genetics* **17**: 481-501. 1932.
 5. BEADLE, G. W. A gene for sticky chromosomes in *Zea mays*. *Zeitsch. Indukt. Abstamm. und Vererbungsl.* **63**: 195-217. 1932.
 6. BRINK, R. A. The occurrence of semi-sterility in maize. *Jour. Hered.* **18**: 266-270. 1927.
 7. BRINK, R. A. Are the chromosomes aggregates of groups of physiologically interdependent genes? *Amer. Nat.* **66**: 444-451. 1932.
 8. BRINK, R. A. and C. R. BURNHAM. Inheritance of semisterility in maize. *Amer. Nat.* **63**: 301-316. 1929.
 9. BRINK, R. A. and D. C. COOPER. The association of semisterile -1 in maize with two linkage groups. *Genetics* **16**: 595-628. 1931.
 10. BRINK, R. A., and D. C. COOPER. A strain of maize homozygous for segmental interchanges involving both ends of the *P-br* chromosome. *Proc. Nation. Acad. Sci.* **18**: 441-447. 1932.
 11. BRINK, R. A., and D. C. COOPER. Chromosome rings in maize and *Oenothera*. *Proc. Nation. Acad. Sci.* **18**: 447-455. 1932.
 12. BRINK, R. A., and D. C. COOPER. A structural change in the chromosomes of maize leading to chain formation. *Amer. Nat.* **66**: 310-322. 1932.
 13. BURNHAM, C. R. Genetical and cytological studies of semisterility and related phenomena in maize. *Proc. Nation. Acad. Sci.* **16**: 269-277. 1930.
 14. BURNHAM, C. A. An interchange in maize giving low sterility and chain configurations. *Proc. Nation. Acad. Sci.* **18**: 434-440. 1932.

15. BURNHAM, C. R. The association of non-homologous parts in a chromosomal interchange in maize. Proc. VI Int. Congr. Genet. **2**: 19-20. 1932.
16. BURNHAM, C. R. Chromosomal interchanges in maize: Reduction of crossing-over and the association of non-homologous parts. (Abst.) Amer. Nat. **68**: 81-82. 1934.
17. BURNHAM, C. R. Linkage relations of certain factors and their serial order in chromosome 5 in maize. (Abst.) Amer. Nat. **68**: 82. 1934.
18. BURNHAM, C. R. Cytology and genetics of an interchange between chromosomes 8 and 9 in maize. Genetics **19**: 430-447. 1934.
19. CLARKE, A. E., and E. G. ANDERSON. A chromosomal interchange in maize without ring formation. Amer. Jour. Bot. **22**: 711-716. 1935.
20. COOPER, D. C., and R. A. BRINK. Cytological evidence for segmental interchange between non-homologous chromosomes in maize. Proc. Nation. Acad. Sci. **17**: 334-338. 1931.
21. CREIGHTON, HARRIET B. Three cases of deficiency in chromosome 9 of *Zea Mays*. Proc. Nation. Acad. Sci. **20**: 111-115. 1934.
22. CREIGHTON, HARRIET B., and BARBARA McCLINTOCK. A correlation of cytological and genetical crossing-over in *Zea Mays*. Proc. Nation. Acad. Sci. **17**: 492-497. 1931.
23. EMERSON, R. A. Genetic evidence of aberrant chromosome behavior in maize endosperm. Amer. Jour. Bot. **8**: 411-424. 1921.
24. EMERSON, R. A. Aberrant endosperm development as a means of distinguishing linkage groups in maize. Amer. Nat. **58**: 272-277. 1924.
25. GOODSSELL, S. F. The relation between X-ray intensity and frequency of deficiency in the maize endosperm. (Abst.) Anat. Rec. **47**: 381-382. 1930.
26. McCLINTOCK, BARBARA. A $2n - 1$ chromosomal chimaera in maize. Jour. Hered. **20**: 218. 1929.
27. McCLINTOCK, BARBARA. A cytological and genetical study of triploid maize. Genetics **14**: 180-222. 1929.
28. McCLINTOCK, BARBARA. A cytological demonstration of the location of an interchange between two non-homologous chromosomes of *Zea Mays*. Proc. Nation. Acad. Sci. **16**: 791-796. 1930.
29. McCLINTOCK, BARBARA. The order of the genes *c sh* and *ux* in *Zea Mays* with reference to a cytologically known point in the chromosome. Proc. Nation. Acad. Sci. **17**: 485-491. 1931.
30. McCLINTOCK, BARBARA. Cytological observations of deficiencies involving known genes, translocations and an inversion in *Zea Mays*. Missouri Agric. Exp. Sta. Res. Bull. 163. 1-30. 1931.
31. McCLINTOCK, BARBARA. A correlation of ring-shaped chromosomes with variegation in *Zea Mays*. Proc. Nation. Acad. Sci. **18**: 677-681. 1932.
32. McCLINTOCK, BARBARA. The association of non-homologous parts of chromosomes in the mid-prophase of meiosis in *Zea-Mays*. Zeitsch. Zellforsch. und Mikr. Anat. **19**: 191-237. 1933.
33. McCLINTOCK, BARBARA. The relation of a particular chromosomal element to the development of the nucleoli in *Zea Mays*. Zeitsch. Zellforsch. und Mikr. Anat. **21**: 294-328. 1934.
34. McCLINTOCK, BARBARA, and H. E. HILL. The cytological identification of the chromosome associated with the *R-G* linkage group in *Zea Mays*. Genetics **16**: 175-190. 1931.
35. METZ, C. W. The role of the "chromosome sheath" in mitosis, and its possible relation to phenomena of mutation. Proc. Nation. Acad. Sci. **20**: 159-163. 1934.
36. RANDOLPH, L. F. Chromosome numbers in *Zea Mays* L. Cornell Univ. Agr. Exp. Sta. Mem. 117. 1-44. 1928.

37. RANDOLPH, L. F. The cytology of certain X-ray effects in maize. Presented before Section O, Amer. Assoc. Adv. Sci., Des Moines (unpublished). 1929.
38. RANDOLPH, L. F. Some effects of high temperature on polyploidy and other variations in maize. *Proc. Nation. Acad. Sci.* **18**: 222-229. 1932.
39. RANDOLPH, L. F. Tetraploid maize. (Abst.) *Amer. Nat.* **68**: 66. 1934.
40. RANDOLPH, L. F., and BARBARA McCLINTOCK. Polyploidy in *Zea Mays* L. *Amer. Nat.* **60**: 99-102. 1926.
41. RHOADES, M. M. Linkage values in an interchange complex in *Zea*. *Proc. Nation. Acad. Sci.* **17**: 694-698. 1931.
42. RHOADES, M. M. The genetic demonstration of double strand crossing-over in *Zea Mays*. *Proc. Nat. Acad. Sci.* **18**: 481-484. 1932.
43. RHOADES, M. M. An experimental and theoretical study of chromatid crossing over. *Genetics* **18**: 535-555. 1933.
44. RHOADES, M. M. A cytogenetical study of a reciprocal translocation in *Zea*. *Proc. Nat. Acad. Sci.* **19**: 1022-1031. 1933.
45. RHOADES, M. M. A secondary trisome in maize. *Proc. Nation. Acad. Sci.* **19**: 1031-1038. 1933.
46. SHARP, L. W. Introduction to cytology. 3rd ed. McGraw-Hill Book Company, Inc.; New York, 1934.
47. SPRAGUE, G. F. Some genetic effects of electromagnetic treatment in maize. (Abst.) *Anat. Rec.* **47**: 382. 1930.
48. STADLER, L. J. Some genetic effects of X-rays in plants. *Jour. Hered.* **21**: 1-19. 1930.
49. STADLER, L. J. Recovery following genetic deficiency in maize. *Proc. Nation. Acad. Sci.* **16**: 714-720. 1930.
50. STADLER, L. J. The experimental modification of heredity in crop plants. I. *Sci. Agric.* **11**: 557-572. 1931.
51. STADLER, L. J. The experimental modification of heredity in crop plants. II. *Sci. Agric.* **11**: 645-661. 1931.
52. STADLER, L. J. On the genetic nature of induced mutations in plants. *Proc. VI Int. Congr. Genet.* **1**: 274-294. 1932.
53. STADLER, L. J. On the genetic nature of induced mutations in plants. II. A haplo-viable deficiency in maize. *Missouri Agric. Exp. Sta. Res. Bull.* **204**: 1-29. 1933.

Manuscript received by the editor August, 1934.

XLIII

BIOLOGICAL ASPECTS OF THE QUANTUM THEORY OF RADIATION ABSORPTIONS IN TISSUES

JOHN W. GOWEN

*Department of Animal and Plant Pathology of The Rockefeller
Institute for Medical Research, Princeton, N. J.*

The amplification of the mendelian theory by other researches shows the chromosomes (58) to contain the specific determiners of the inheritance, the genes, arranged linearly with regard to each other. The total effects of these genes control the development and maintenance of all parts of the adult organism. Individually considered, however, the effects are quite specific. A gene may alter the eye color or reduce the wings of *Drosophila* but otherwise show little to indicate its presence. One may make a harmless black spot under the wing joint (58), while another may cause a focal melanosis (24) in the leg joints ultimately resulting in the death of the fly. Organs vital to the fly may be altered in shape and structure as the result of the presence of specific genes. And finally a large class of genes exists in which each one of them under the proper conditions, when dominant or homozygous, causes the death of the organism containing it in its cells.

The distribution of these different types of genes is apparently at random within the cell chromatin. A gene whose function it is to assist in producing a certain eye color may have as its known neighbor a gene which causes death or a gene which acts upon the legs, the wings, or any other part of the body. Random chance alone seems to determine the spatial order of the different types of genes within their linear order. A given gene's position within this linear order is ordinarily fixed. For every known gene difference at least two genes capable of producing markedly different effects on the same organ, or less frequently on different organs, may occupy the same position, locus, within the chromosome. Dividing the genes into groups according to the broad categories of character changes which they produce and according to their location within the chromatin structure, we have genes which produce dominant or recessive characters, dominant or recessive lethals. These may be autosomal or sex-linked. The presence of the recessive lethals is well proved by the study of their genetics. The fact of dominant lethal genes has less, though growing, evidence in its support.

Genetic evidence on the occurrence of natural mutation seems to show that the frequency with which genes change by mutation into others which are lethal is considerably greater than the frequency with which they mutate to those having visible nonlethal effects. Data on mutation ratios of normal genes exposed to X-ray likewise bear out this same conclusion (12, 25, 27 to 39, 59 to 69, 70, 71, 81).

Coincident with the genetic research but having different personnel and objectives, investigators have used X-rays and radium in medicine, as in the treatment of neoplasms, and in biology, as in studying abnormal growths. In both cases the end result rather than the process by which this result was attained was the important consideration. The descriptive facts, while at the time seeming to give little insight into the real nature of the changes or their cause, may have more significance. The series of experiments of Hertwig and his students (41, 42) showed that the beta and gamma rays of radium can injure the sperm or egg nucleus without destroying either cell's activity in the fertilization process. An irradiated sperm is motile and can initiate development in the normal egg. If a slight irradiation is given, it may cause abnormal mitosis with the ultimate death of the egg it fertilizes. If more heavily irradiated, it may cause development to start but play no more part in it, although the development is often quite normal. The nuclei in such embryos are haploid. A like situation where the egg nucleus is functionally destroyed with the cytoplasm remaining normal is noted in irradiated eggs of *Chaetopterus* (72). The sperm nucleus under these conditions continues normal development. The nuclear material, chromatin, is most sensitive to the irradiation, while the rest of the cell protoplasm either takes a much larger amount of energy to affect it or the cytoplasmic changes seen in the later stages of cell degeneration of irradiated cells really arise in previous nuclear mutations.

The interpretation of the cause of death of an organism irradiated by X-ray or radium as due to the absorption of the energy in discrete quanta within a relatively small vital spot within the cell seems to have occurred independently to several investigators (4, 8, 9, 10, 11, 14, 15, 17 to 21, 44 to 48, 93 to 97). The theoretical grounds on which this reasoning was based arose largely in physical considerations—the significance of the biological facts of mutation and lethal factors not then having been appreciated. The X-rays were regarded as being absorbed in tissue as discrete units. If a is the probability that an electron will hit the object under experimentation and n the number of electrons, then the probability that the object will be hit just once is

$$na(1 - a)^{n-1}$$

The probability that the object will absorb r electrons out of the n possible is

$$\frac{n(n-1)(n-2) \cdots (n-r+1)}{r!} a^r (1-a)^{n-r}$$

These considerations and the fact that the number of electrons is large compared with the number required to kill, r , lead to Poisson's law as the general theorem to describe these results

$$P = \frac{1}{r!} (an)^r e^{-an}$$

Or for the case when one electron absorption will suffice to produce the observed result, the number of experimental objects escaping the electrons will be

$$A_1/A_0 = e^{-an}$$

This curve plots as a straight line on the semilogarithmic grid. When two absorptions are necessary, the ratio of those showing no effect to the original number is A_2/A_0 and equals $e^{-an}(1+an)$. This curve plots as a convex curve on the semilogarithmic grid. Or where r absorptions are necessary, the ratio is

$$A_r/A_0 = e^{-an} [1 + an + \frac{1}{2}(an)^2 + \cdots + \frac{1}{r!}(an)^r]$$

Values of r as high as 50 have been noted in data taken from different experimental objects, depending sometimes on the material and at others on the technique. The simplest type of curve where but one absorption is necessary for death is seen for certain bacteria, *Drosophila* sperm, and possibly *Antirrhinum* pollen, when exposed to X-ray. Figure 1 shows data taken from Wyckoff (93, 93a, 94, 96) which demonstrate the linear nature of the death rates (on the semilogarithmic grid) of *B. coli* when they are exposed to electrons of the cathode-ray tube or irradiation from X-rays of 0.564- to 3.98-Å wave-lengths or ultra-violet radiation in the range 2536 to 3132 Å. In all cases the curves pass through the point of 0 treatment at the 100-per-cent survival, there being no lagging of the deaths in the range of the lower doses.

More complex types of survival curves have been noted for many experimental objects. These types may arise from several causes, one of the most prevalent of which is the many-celled character of the material. Wyckoff and Rivers (96) have shown that if the cells of *B. coli*—which give the simple straight-line curves of Fig. 1 when they are distributed as single cells over the culture plate at irradiation—are incubated a short time so that each cell becomes a tiny colony of two or more cells, the survival curve of such a population on irradiation with cathode rays is no longer a straight line on the arithlog grid but a convex curve having a low initial death rate with a subsequent rapid increase after the short lag period. The two or more cells in each colony which must be killed before that individual may be recorded as dead by the X-ray obviously require

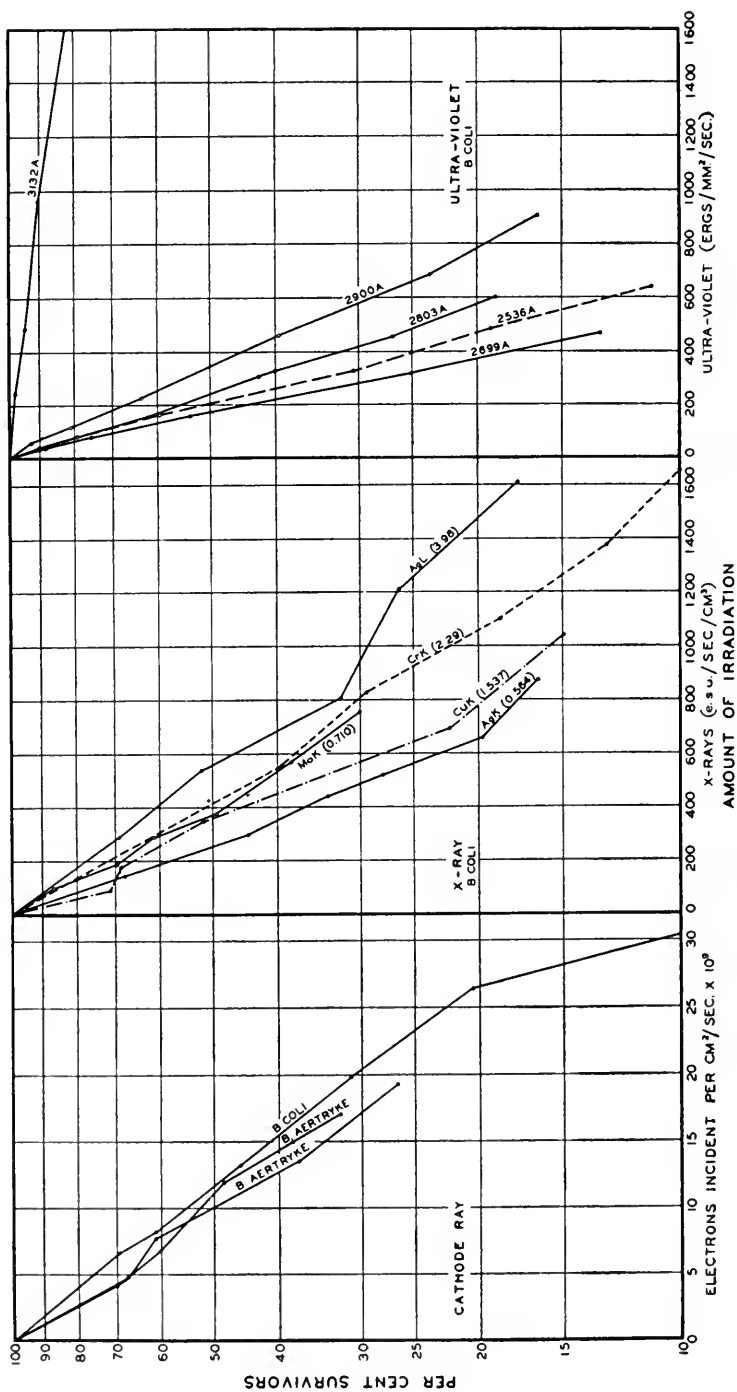

Fig. 1.—Survival curves of *B. coli* exposed to radiation, cathode, X-ray, and ultra-violet.

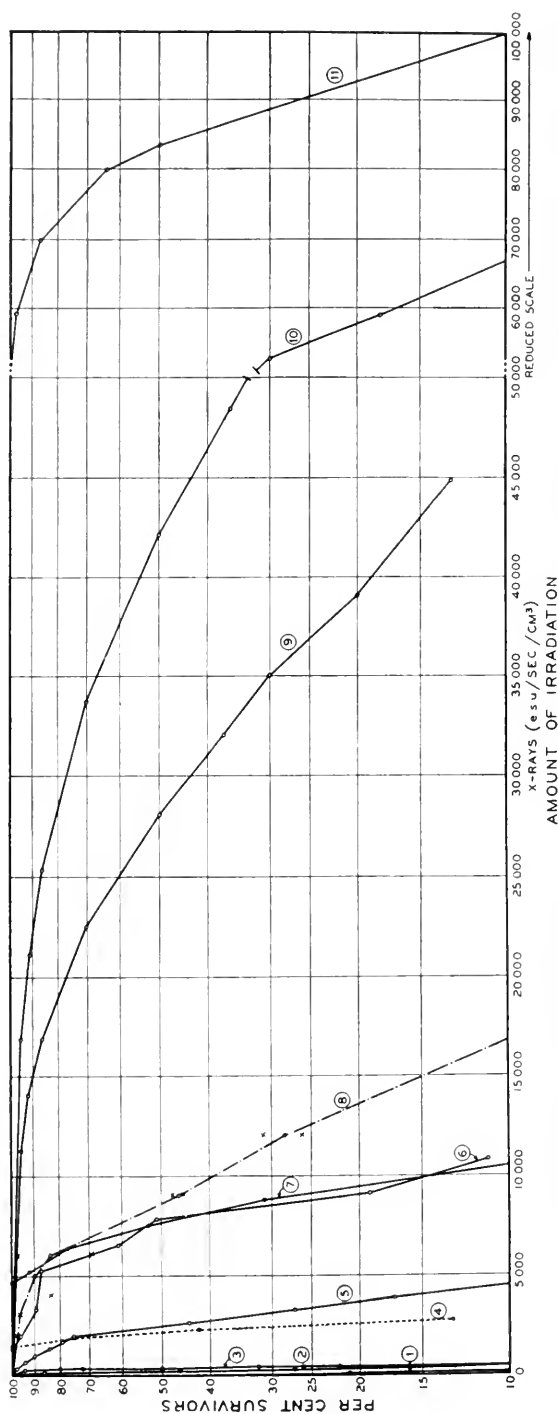

Fig. 2.—Survival curves of the multiple absorption for death type. The curves are obtained as follows: 1, *Arotoll* eggs, read directly from H. and M. Langendorff and Reuss, Fig. 1, p. 292 (54); 2, *Drosophila* directly from the data of Packard (73, 73a, 73b, 74-77); 3, *Vicia Faba* from Fig. 8, p. 150, when $q_{1/2} = 370$ r (21); 4, sunflower, and 7, mustard, Figs. 1 and 2, p. 30 and 31, when $q_{1/2} = 2230$ r and 7650 r, respectively (21a), 5, *Saccharomyces cerevisiae*, and 6, *Rhizopus nigricans* (55); 8, *Mesotanium californicum* (54a); the 9-10, *Saccharomyces ellipsoideus* (1.54 Å and 0.56 Å) from Fig. 2, p. 522, when $q_{1/2} = 28,000$ r and 42,000 r, respectively (20); 11, *Colpidium colpota* (10).

at least two absorptions before death takes place. The published survival curves for organisms like staphylococci which experience has shown to be difficult, if not impossible, to separate into individual cells before irradiating seem to have a like interpretation. The many-celled nature of the material also affects the curves for small pieces of tumor tissue, bean, sunflower, and mustard-root tips (21, 21a), or *Drosophila* eggs.

Other multiple-absorption curves apparently cannot be accounted for by the numbers of cells which compose the objects irradiated, since the objects seemed to be in a single-celled stage [yeast (20), alga (54a), *Rhizopus* spores (55), ascaris eggs (6), and the protozoan *Colpidium colpoda* (10)]. In accounting for the survival curve of *Colpidium*, Crowther (10) showed that the long delay in the time between the commencement of exposure to the X-rays and the beginning of the deaths was explicable on the assumption that more than one absorption in the vital spot was necessary to cause death, the least number of absorptions which he considers sufficient being 49. In yeast, Glocker, Langendorff, and Reuss (20) consider five absorptions necessary to kill. For alga, Langendorff and Reuss allow three absorptions, and for *Ascaris* four to six are considered necessary in the Braun and Holthusen data (6). Illustrations of these multiple-absorption types of survival curves are shown in Fig. 2.

Glocker and Reuss (21) have utilized both hypotheses, the many-celledness, and the necessity for multiple absorption, to explain the mechanism by which certain of their experimental survival curves are derived. They have also adopted the idea that the wave-length of the incident beam plays a part in the severity of the effect produced. In data on the root tips of the horse bean, sunflower, and mustard seeds, they were able to show a difference between survival curves of these objects when the wave-lengths of the incident beam were 0.56 and 1.54 Å. These curves were centered on the point of 50 per cent survival and the dose scale converted to a ratio of the actual dose divided by the 50 per cent, $q/1/2q$. At the shorter wave-lengths the roots died more slowly at first, then more rapidly than those of the 1.54 Å. The differences are generally small, though rather consistent. The method of presenting the data only in graphs does not allow the estimation of their statistical significance. The effect of the wave-length is not seen in other forms, bacteria, yeast, an alga, *Ascaris*, or *Drosophila* eggs.

The wide variation in the survival curves of the different species (Fig. 2) shows that pronounced differences exist between living forms and their reactions to irradiation. This variation in the sensitivity of species, due to the normal biological variations of inheritance or environment, has suggested to several investigators that like, though possibly smaller, biological variations account for the form of the survival curve within

species (76, 97). The analysis of this problem requires rather special material having a broad background of embryological, cytological, and genetic information. The facts of particular experiments can then find their proper place in the interpretations assigned to the experiments. Such material is limited, the best available being *Drosophila*.

The physical hypotheses adopted to account for irradiation effect on tissue universally consider the cell as containing a sensitive spot within which the X-ray absorptions are to occur if death is to result. Genetic considerations suggest that this concept be modified to accommodate the evidence described earlier. The chromatin, as shown by the experiments of Hertwig (41, 42), is the most sensitive material of the cell to irradiation. Radiant energy may affect this material and some of its constituents in various ways. It may cause mutation of the genes to others having different effects, or it may break the connection between genes with the result that the reorganized chromosome has a quite different constitution from that of the original. It may affect the mechanism of meiosis and result in abnormal germ cells. Different as the effects are, they are all localized in minute space, suggesting the sphere of influence of an electron absorption. Genetic methods show that these effects may be localized within any part of the chromatin. They need not be lethal, although they often alter the genes to make them so. Biologically the sensitive spot of the physical concept becomes many sensitive spots within the chromatin. The reasoning from probability will still apply, however.

To produce death in the object irradiated it is necessary to injure the cell so that it will no longer function properly in division and development. This injury would appear to be in the nature of a gene change to convert it into a dominant lethal similar, save for its dominance, to the observed recessive lethals responsible for death in the second generation. This view receives support from the fact that the sex ratios of the progeny of irradiated sperm fertilizing normal eggs, or of irradiated sperm fertilizing attached X-eggs in *Drosophila*, behave as they should if such dominant lethals were produced. The effect on the sex ratio in forms like *D. obscura* having a large X-chromosome is greater than in forms with a small sex chromosome. This evidence is not completely critical, however, for defects produced in the chromosome framework rather than the genes could account for the result. It is more difficult to account for the following evidence except by the production of dominant lethal mutations. The sex chromosome of *D. melanogaster* is known to have one-half to two-thirds of its length empty of genes (26, 78). It is however, possible for this chromosome to break and reattach to another chromosome, the break occurring within the empty (?) region. If we assume that the lethal effects of irradiation are due to chromatin aberrations as against dominant lethal gene mutations, then we would expect that the proportion of such abnormalities would be in the ratio of the chromatin in the

sex chromosome to the total chromatin. In the other hypothesis, if the deaths are due to dominant lethal mutations of genes present in the sex chromosome, the proportion would be quite different, the ratio of sex-linked gene material to the gene material in the other chromosomes. The data show that the proportion of the deaths attributable to the sex chromosome is only about one-third of those expected were they comparable with those found due to all the chromatin. This evidence consequently favors the hypothesis of dominant lethals as the cause of deaths due to radiant energy (25).

Energy of the alpha particle, cathode ray, gamma ray, X-rays, ultra-violet radiation, and of heat is capable of making the different categories of gene and chromosome changes, visible mutations, dominant or recessive, lethal mutations, broken and reorganized chromosome, and irregular meiotic separations. The alpha particles have produced only somatic modifications resembling the effects commonly noted in gene mutations (36). Cathode rays in preliminary experiments of the writer caused mutations (see also 56). Gamma rays and X-rays are both effective in causing mutations of all types. Ultra-violet radiation seems to be capable of making gene mutations, provided it can penetrate to the germ cells. In the first work on *Drosophila* (1) and *Antirrhinum* (89a) no effect of ultra-violet was reported. Wild-type flies and buds were treated in these experiments. Later experiments (1, 89) designed to allow the ultra-violet energy to reach the germ cells and not be absorbed by the somatic tissue have shown clearly that energy of this wave-length is capable of causing mutation. Similar mutations due to heat have been recorded (22, 50, 62, 84, 85). Recessive lethal mutations furnish what is perhaps the best measure of these effects. The rates at which these lethals are produced in the sex chromosome for X-rays and radium of different ionization strengths are shown in Fig. 3.

Drosophila males containing mature sperm were irradiated in each case. The percentage of lethal mutations obtained per electrostatic unit was least with the gamma rays of the radium and greatest with rays from a tungsten target filtered through 0.5 mm. of aluminum. Within any one experiment, the curve for the percentage of sex-linked lethal mutations produced, plotted against amount of irradiation on the arithlog grid, takes its origin at the 0 dose and 100 per cent survivors. The lines formed by the mutation rates against dosage are straight. These facts point to the interpretation that one absorption in the genes is sufficient to alter it to one of another type. The range of wave-lengths for which this is true varies from 0.01 Å for the gamma rays, 0.7 Å for the tungsten-target tube, 1.5 Å for the copper-target tube, and 2.2 Å for the chromium-target tube. Radiant energy of the shortest wave-lengths, gamma rays, and of the longest wave-lengths, copper and chromium (1.537 and 2.23) produced mutations at lower rates than did those of intermediate wave-

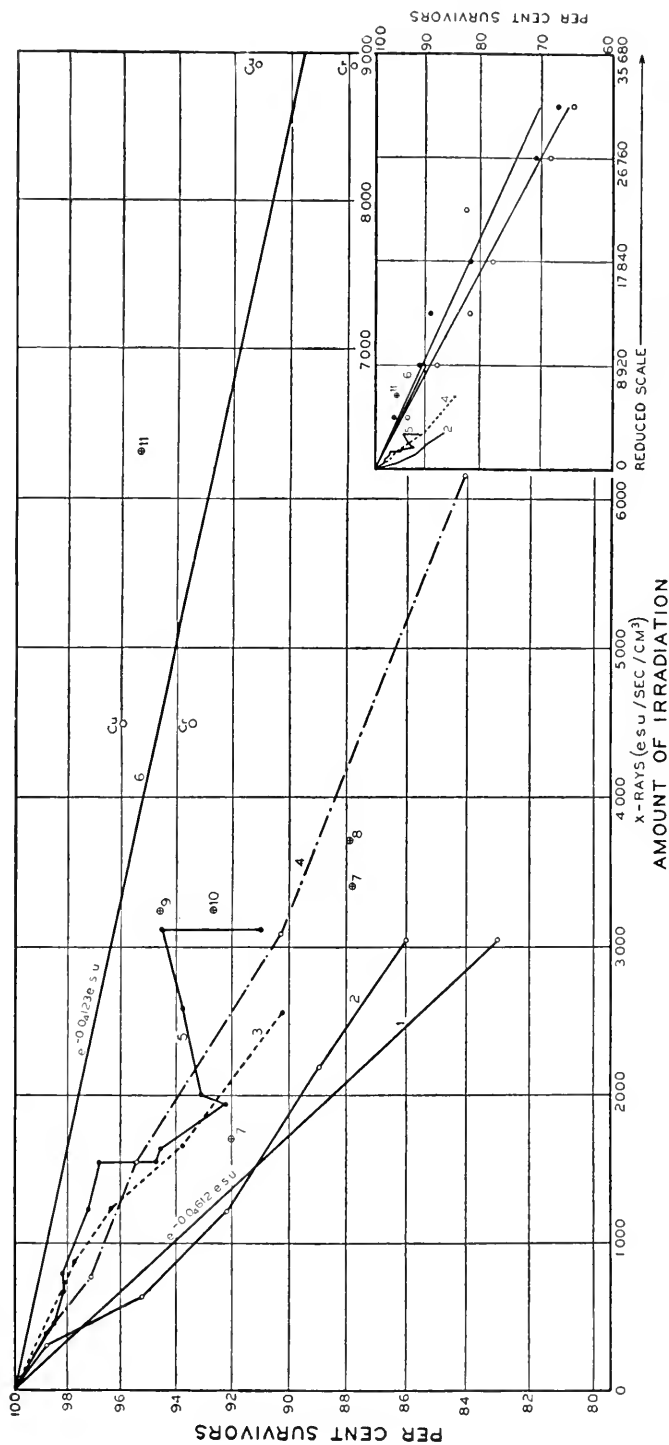

Fig. 3.—Percentage of sex chromosomes which showed no recessive lethal mutations after irradiation of *Drosophila* sperms. 1 and 2, Demerec (12); 3, Patterson (81); 4, Oliver (70); 5, Hanson, Heys, and Stanton (39); 6, Gowen and Gay (25); 7, Muller (59); 8, Muller (67); 9 and 10, Medvedev (57); 11, Hanson and Heys (35).

lengths. Between the curve for chromium and the curve of Demerec for tungsten lie the results of the other investigators. This broad variation from a curve of a slope of $e^{-0.76 \text{ e.s.u.}}$ to one of $e^{-0.61 \text{ e.s.u.}}$ may in part be accounted for by inaccuracies in measuring the ionization dose. This explanation does not seem likely for the data of Hanson on gamma rays, of Demerec with tungsten, or of those for the copper and chromium. Two other possibilities of accounting for this variation suggest themselves: (a) The absorption of energy within the fly tissues before the sperm are reached may be rather high in the long wave-lengths. This fact could bring this material nearer the observations on the heterogeneous rays of tungsten, although in view of the direction of the differences between the copper and chromium results, this interpretation would appear unlikely. It will furthermore not account for the gamma-ray data. (b) The second possibility is that chromatin may have a band specific absorption for X-rays in the tungsten region, 0.7 Å. This, too, seems unlikely. The explanation of these variations needs more extended data from the same laboratory where under like conditions radiant energy over a wide range of wave-lengths may have its effects determined.

The curves of Fig. 3 are all of a form which suggest that a single absorption in a gene is sufficient to produce a mutation. This fact is further borne out by genetic evidence. The mutation of one gene, although it is itself small, generally has no effect on other genes so far as the writer's evidence has shown (25). The occurrence of other mutations within a chromosome is the result of other random absorptions. The development of the sperm (although it is generally haploid) sometimes leads to the growth of the genes and their splitting into two new ones. Evidence is available to show that despite the close proximity of these two genes one may be affected by X-ray while the other remains unchanged (25, 59, 61). The average sphere of action of the rays is therefore small, as it should be by physical theory. Different genes within the chromosome are, of necessity, close together. Muller (66) has stated, although without presenting data, that in his opinion a gene next to one which mutated also mutated more frequently than it should by chance. From this fact he has argued that mutation may be in the nature of a chain reaction where the energy only starts a process capable of spreading to other close genes. He considers that the ions, even taking the chance straight path which they sometimes do, would be unable to reach both genes because the distance is thought to be too great. The data on which this hypothesis is built are quite naturally scanty at this stage of the work. In the writer's own research, where the foregoing possibility was clearly in mind during the experiment, no evidence in its support was obtained. For the present at least the direct-action theory as the method by which the X-rays produce their effects seems adequate.

By accepting certain hypotheses, the nature of which will be made clear, it is possible to arrive at an estimate of the number and maximum size of the genes, the total volume of which makes up the sensitive spot (of the physical interpretation) within the irradiated cell of *Drosophila* (25). From our experiments we obtained as the result of X-ray mutation, 44 sex-linked mutations producing consistent visible effects and having a viability of 20 per cent or more. In the same material 320 sex-linked mutations having a viability of less than 20 per cent were observed, a ratio of 1:7.3. The 44 visible mutations allow us to form an idea of the number of these genes within the sex chromosome. As a first approximation we shall assume that all genes are equally likely to mutate, a proposition which, if it errs, (88) will be on the side of giving us too few genes rather than too many and consequently too large a size for the average gene.

Two samplings have been made from this total population of loci. The first sampling followed the period of years during which the evidence for the existence of any of the loci came as the chance occurrence of natural mutations. Morgan, Bridges, and Sturtevant (58) have tabulated these genes. The sex-chromosome genes of this series, comparable to the 44 which we have described before, fall into 42 loci. If this same population of genes is sampled, the chance of obtaining a gene occupying any one of these loci in one draw is thus $\frac{42}{\text{total loci} \times 44}$.

The experiment showed 6 proven identical loci and 8 very probable identical loci, or 14 in all. The experimental results set the answer to the above equation as 14; $\frac{42}{\text{total loci} \times 44} = 14$, or total loci = 132. Thus the sex chromosome may contain 132 genes which can undergo rather easily detectable and fairly viable mutations. It may be argued that only the 6 proven allelomorphs should be used in the calculation. This would lead to an estimate of the number of loci as 308. Other methods of estimating the number of these genes give like results. One hundred and seventy-five was adopted as a fair estimate of the number. There would thus be 175×7.3 , or 1280, genes with a viability of less than 20 per cent on mutating. But the minimum estimate of 132, or 950 loci, may be nearer the true total, since Muller's (66) data by like technique lead to about 700 loci, and Demerec's, by a different approach, to 500.

The size of the sex chromosome on measurement was found to be length 1.56×10^{-4} cm. \times breadth 0.33×10^{-4} cm., or 5.148×10^{-9} cm.² in area.

To find the total number of absorptions of the sex chromosome with rays of this strength we may proceed as follows: In our experiment with

copper radiation 148.7 electrostatic units were given per sec./cm.² in 1 cm. of air.

The number of ion pairs per sec./cc. at the position of the irradiated sex chromosome is consequently $148.7 \times$ electrons in one electrostatic unit, or 0.21×10^{10} ion pairs/sec. = 3.12×10^{11} ion pairs/sec./cc.

For material composed of atoms of low atomic weight these absorption coefficients vary directly with the density of the substance. If this conclusion is applied to chromatin, the amount of absorption per sex chromosome is

$$\frac{3.12 \times 10^{11} \times 1.70 \times 10^{-13} \times 1.00}{1.00 \times 1.165 \times 10^{-3}} =$$

45.5 ion pairs/sec. per sex chromosome.

Since direct measurement of the dimensions of the sex chromosome are 1.56×10^{-4} cm. long and 0.33×10^{-4} cm. wide, hence—considering the sex chromosome a rectangular block of chromatin—the volume is 1.70×10^{-13} cc. The density of chromatin is assumed to be 1.00 and the density of the air at the temperature used is 1.165×10^{-3} .

In order to obtain the number of X-ray quanta absorbed per second it is necessary to know how many ions are liberated by one quantum absorbed in air. The best available measurements (Kulenkampff, 51) show that X-rays of the quality used require about 35 volts for each electron pair. The voltage equivalent of the K - α lines of copper follows from the quantum relation: Voltage (in kv.) = $12.34/\text{wave-length}$ of copper X-rays (1.537) = 8.029 kv.

The number of ion pairs arising through the absorption of one quantum of Cu K - α X-rays is $8,029/35 = 229$. The average number of quantum absorptions per second is $45.5/229 = 0.199$.

The average number of absorptions which actually produced mutation was determined from the experimental data by fitting the curve previously derived, $\text{survival} = e^{-ant}$, to the actual data by the method of least squares. The resulting curve was $Y = e^{-0.0165t}$.

If the sex chromosome was entirely composed of vital recessive genes then every hit would be expected to kill, or the rate of killing with time should be 0.199 per second. The exponent 0.00165 per second for the actual data shows that this is not the case. The chance of hitting the vital volume within the sex chromosome clearly decreases as its volume relative to the whole sex chromosome becomes less. The theoretical absorption 0.199 per second represents the whole volume. The effective absorption 0.00165 represents the vital volume. Their ratio, 1.0:0.00829, represents the whole volume compared with this vital volume. In other words, the sex-chromosome volume has 829 hundred-thousandths of its volume composed of vital dominant genes. Since there are 1280 of these genes, the average size of one of them would be

$$\frac{1.70 \times 10^{-13} \times 8.29 \times 10^{-3}}{1280} = 1.1 \times 10^{-18} \text{ cc.}$$

The figure 1.1×10^{-18} cc. is, of course, not the gene volume but rather the purely physical space within which the absorption is effective. The gene could not well be larger than this volume but easily could be smaller. A calculation adopting a somewhat different approach and coming to a somewhat larger figure has also been made by Blackwood (3) on Muller and Altenburg's data.

The number of different genes which might be discovered through alterations produced by X-ray in a *Drosophila* sperm would be of the order of 15,000 to 30,000. The number of loci in any one sperm would be 9000 to 15,000. These estimates are larger than those derived from Muller's or Demerec's data. They are also four times larger than the estimates of the number of gene loci based on the supposition that the bands of the salivary gland chromosomes represent loci of particular genes.

The foregoing analysis suggests the manner in which the total number of gene loci within an organism may be estimated. It suffices to say here that, depending on certain assumptions, the numbers necessary to this small fruitfly seem to be not lower than 2000 or more than 15,000. The magnitude of either of these numbers is entirely sufficient to show the complexity and importance of the sensitive spot in the physical concept. Possibly all these loci, with their contained genes, are essential. Certainly the rarely occurring natural mutations or the more rapidly produced mutations due to X-rays show that but 8 to 17 per cent of these genes may be mutated and support life.

It may be asked how the change in susceptibility of an object to X-rays may be related to such a theory. In other words, what may be the biological basis for the variation in sensitiveness of different materials? The *Drosophila* egg is worth discussing from this viewpoint since so much is known about it. The death rates of these eggs and of *Drosophila* sperm are shown in Fig. 4.

The *Drosophila* eggs at 2 hr. after laying are much more sensitive to the X-rays than are the sperm. The two graphs for the sperm show a fairly wide divergence in their results, perhaps nearly the extremes, similar to that seen in the recessive lethals. The egg-survival curves show a distinct curvature, whereas the curves for the sperm are straight lines when plotted on the semilogarithmic grid. From this fact we would infer that the egg requires more than one absorption in the vital areas whereas the sperm needs but one to kill. *Drosophila* eggs are about 0.5 mm. long and 0.2 mm. in width and depth. The nuclei within them are diploid. In view of the fact that all eggs hatching earlier than 18 hr. are discarded, it would seem that the eggs making up these data are at most only at the few-celled stage when they are laid. The time

necessary for a division of the nuclei is according to Huettner (49) 10 min. at 23°C. Packard (75) places the time at 1 hr. at 13°C. and 15 min. at 28°C. The numbers of nuclei in the eggs would increase in geometrical ratio with time. If the cause of death in irradiation is the production of dominant lethal mutations, the susceptibility of the egg should change from the time it is in the single-nucleus stage, when theoretically it should be twice as susceptible as the sperm, to double the susceptibility at each

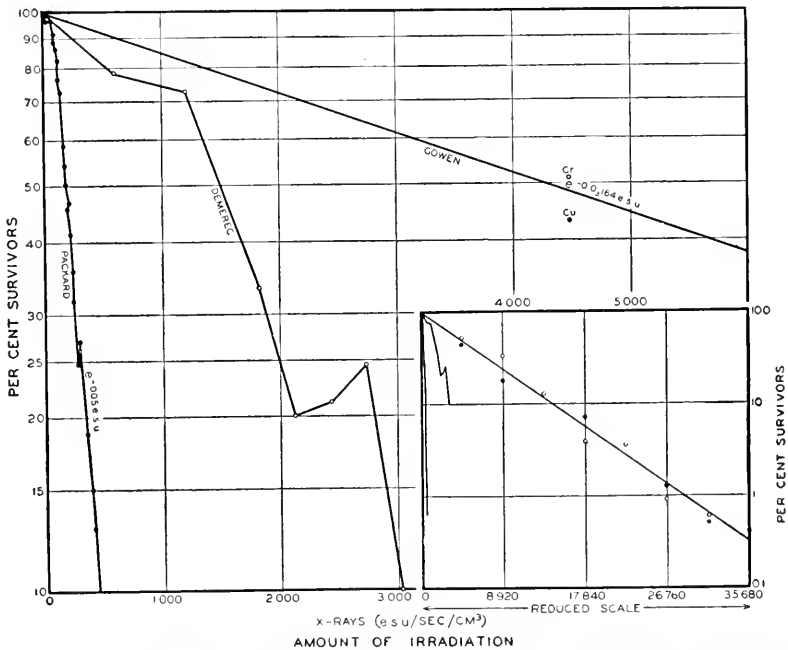

FIG. 4.—Survival curves for *Drosophila* eggs (at 1 to 3 hr. from laying), chromatin diploid, and sperm, chromatin haploid.

rhythm of cell division provided each nucleus is essential to further development. According to Packard's work, the *Drosophila* eggs do increase in sensitivity until they are most sensitive at 2 hr. from laying, when they become less sensitive. This becoming less sensitive seems also to have a meaning in the course of development. Patterson (79, 80) and Gowen (23) showed that the anlage of the adult eye of *Drosophila* was in the one-celled stage not longer than 12 hr. after the egg was laid and very possibly less time than that. If the vital organs differentiate even more rapidly so that they become two-celled early in development, requiring that both be destroyed to cause the egg's death, then a multiple-absorption curve will be necessary to account for the observed deaths. This increase gives the appearance of increased resistance of the cell to X-rays after such a critical period is passed. The data are not accurate

enough for an exact quantitative comparison. The *Drosophila* survival curve apparently requires r of our earlier formula to be 3 or 4. That is, the most susceptible period is somewhat past the stage when the destruction of any nuclei is fatal. If the rates of death are compared it is found that to have an equally sensitive volume to that of the egg would take as a target something over a hundred sperm. The stage of development of these eggs is unknown, but it seems unlikely that it is less than the 2⁶ nuclei, or the stage when the chromatin volume of the egg would equal that required for the sensitivity indicated. The maximum number of nuclei at this stage would seem to be 2¹². The same line of reasoning will account for the increase in susceptibility of the eggs with the temperature at which they are previously developed.

The foregoing discussion of the relative mortalities of the *Drosophila* egg and sperm is presented only to show the manner in which well-known biological factors might affect susceptibility to X-rays if the rays affected the cell in the manner here discussed. There is one piece of evidence which, unless the biological fact of decreased vitality through age or some such variable accounts for the observed facts, would mitigate against the theory of the direct effect of X-rays as due to random absorption in a relatively limited area of the chromatin. Hanson and Heys (37) have shown that males which are irradiated with the same dose in r -units and time at birth, 6, 12, 18, 24, and 32 days of age, show a progressively declining rate of mutation; 13.8, 11.3, 8.9, 5.8, 2.1, and 0.6 per cent, respectively. No analysis of the reasons behind this decline in observed mutation is presented.

SUMMARY

This paper discusses the biological aspects of the quantum theory of radiation absorptions. The genetic results for X-ray treatments show that the X-rays produce their effects on chromatin in minute localized volumes. These volumes are of the order of 1×10^{-18} cc. and may number 2000 to 15,000 to the cell.

REVIEW REFERENCES

- LOEB, L. Effects of Roentgen rays and radioactive substances on living cells and tissues. *Jour. Cancer Res.* **7**: 229-282. 1922.
- OLIVER, C. P. Radiation genetics. *Quart. Rev. Biol.* **9**: 381-408. 1934.
- PACKARD, C. The biological effects of short radiations. *Quart. Rev. Biol.* **6**: 253-280. 1931.
- TIMOFÉEFF-RESSOVSKY, N. W. Die bisherigen Ergebnisse der Strahlengenetik. *Ergeb. Med. Strahlenforsch.* **5**: 129-228. 1931.

REFERENCES

1. ALTENBURG, E. The effect of ultraviolet radiation on mutation. *Anat. Rec.* **41**: 99. 1930. (Abstr.)

2. ALTENBURG, E. Genetic effects of ultraviolet radiation. *Anat. Rec. Supp.* **1**: 108. 1931. (Abstr.)
3. BLACKWOOD, O. Further x-ray evidence as to the size of a gene; and as to the energy of mutation by ultraviolet rays. *Physical Rev.* **40**: 1034. 1932. (Abstr.)
4. BLAU, M., and K. ALTENBURGER. Über einige Wirkungen von Strahlen II. *Zeitsch. Phys.* **12**: 315-329. 1922.
5. BOSTIAN, NEITA C. Sex ratios of mutants from x-rayed adult females of *Habrobracon*. *Anat. Rec. Supp.* **1**: 121. 1931. (Abstr.)
6. BRAUN, R., and H. HOLTHUSEN. Einfluss der Quantengrösse auf die biologische Wirkung verschiedener Röntgenstrahlenqualitäten. *Strahlentherapie* **34**: 707-734. 1929.
7. COLWELL, H. A., and S. RUSS. Radium, x-rays, and the living cell. Bell and Sons.; London, 1924
8. CONDON, E. U., and H. M. TERRILL. Quantum phenomena in the biological action of x-rays. *Jour. Cancer Res.* **11**: 324-333. 1927.
9. CROWTHER, J. A. Some considerations relative to the action of x-rays on tissue cells. *Proc. Roy. Soc. London B* **96**: 207-211. 1924.
10. CROWTHER, J. A. The action of x-rays on *Colpidium colpoda*. *Proc. Roy. Soc. London B* **100**: 390-404. 1926.
11. CURIE, MME, P. Sur l'étude des courbes de probabilité relatives à l'action des rayons x sur les bacilles. *Compt. Rend. Acad. Sci. [Paris]* **188**: 202-204. 1929.
12. DEMEREC, M. The effect of x-ray dosage on sterility and number of lethals in *Drosophila melanogaster*. *Proc. Nation. Acad. Sci.* **19**: 1015-1020. 1933.
13. DEMEREC, M. Gene deficiencies or cell lethals in *Drosophila melanogaster*. *Rec. Genet. Soc. America* **2**: 57. 1933.
14. DESSAUER, F. Über einige Wirkungen von Strahlen I. *Zeitsch. Phys.* **12**: 38-47. 1922.
15. DESSAUER, T. Über einige Wirkungen von Strahlen IV. *Zeitsch. Phys.* **20**: 288-298. 1923.
16. DOBZHANSKY, T. Cytological map of the second chromosome of *Drosophila melanogaster*. *Biol. Zentralbl.* **50**: 671-685. 1930. (See also *Genetics* **15**: 347-399. 1930.)
17. GLOCKER, R. Die Wirkung der Röntgenstrahlen auf die Zelle als physikalisches Problem. *Strahlentherapie* **33**: 199-205. 1929.
18. GLOCKER, R. Vorschlag einer abgeänderten Definition der Röntgeneinheit. *Radiology* **18**: 93-98. 1932.
19. GLOCKER, R. Quantenphysik der biologischen Röntgenstrahlenwirkung. *Zeitsch. Phys.* **77**: 653-675. 1932.
20. GLOCKER, R., H. LANGENDORFF, and A. REUSS. Über die Wirkung von Röntgenstrahlen verschiedener Wellenlänge auf biologische Objekte. III. *Strahlentherapie* **46**: 517-528. 1932.
21. GLOCKER, R., and A. REUSS. Über die Wirkung von Röntgenstrahlen verschiedener Wellenlänge auf biologische Objekte. I. *Strahlentherapie* **46**: 137-160. 1933. [See also (a) V. *Ibid.* **47**: 28-34. 1933.]
22. GOLDSCHMIDT, R. Experimentelle Mutation und das Problem der sogenannten Parallelinduktion. Versuche an *Drosophila*. *Biol. Zentralbl.* **49**: 437-448. 1929.
23. GOWEN, J. W. On the nature of gene action. *Science* **70**: 358-360. 1929.
24. GOWEN, J. W. The inheritance of focal melanosis in *Drosophila*. *Arch. Path.* **17**: 638-547. 1934.
25. GOWEN, J. W., and E. H. GAY. Gene number, kind, and size in *Drosophila*. *Genetics* **18**: 1-31. 1933.

26. GOWEN, J. W., and E. H. GAY. Chromosome constitution and behavior in eversporting and mottling in *Drosophila melanogaster*. *Genetics* **19**: 189-208. 1934.
27. HANSON, F. B. An analysis of the effect of different rays of radium in producing lethal mutations in *Drosophila*. *Anat. Rec.* **41**: 99. 1928. (Abstr.)
28. HANSON, F. B. The effect of x-rays on productivity and the sex ratio. *Amer. Nat.* **62**: 352-362. 1928.
29. HANSON, F. B. The effect of x-rays in producing return gene mutations. *Science* **67**: 562-563. 1928.
30. HANSON, F. B., and FLORENCE HEYS. The effects of radium in producing lethal mutations in *Drosophila melanogaster*. *Science* **68**: 115-116. 1928.
31. HANSON, F. B., and FLORENCE HEYS. The effect of natural (earth) radiation in producing lethal mutations in *Drosophila melanogaster*. *Anat. Rec.* **44**: 293. 1929. (Abstr.)
32. HANSON, F. B., and FLORENCE HEYS. Duration of the effects of x-rays on male germ-cells in *Drosophila melanogaster*. *Amer. Nat.* **63**: 511-516. 1929.
33. HANSON, F. B., and FLORENCE HEYS. An analysis of the effect of different rays of radium in producing lethal mutations in *Drosophila*. *Amer. Nat.* **63**: 201-213. 1929.
34. HANSON, F. B., and FLORENCE HEYS. A possible relation between natural (earth) radiation and gene mutation. *Science* **71**: 43-44. 1930.
35. HANSON, F. B., and FLORENCE HEYS. Radium and lethal mutations in *Drosophila melanogaster*. I, II. *Anat. Rec.* **51**: 122. 1931. (Abstr.) [See also *Ibid.* **51**: 121. 1931. (Abstr.)]
36. HANSON, F. B., and FLORENCE HEYS. The effects of alpha radiation from polonium in producing somatic modification in *Drosophila*. *Rec. Genet. Soc. America* **2**: 57. 1933. (See also *Ibid.* **2**: 58. 1933.)
37. HANSON, F. B., and FLORENCE HEYS. The relation of the induced mutation rate to different physiological states in *Drosophila melanogaster*. III. *Amer. Nat.* **68**: 97-106. 1934.
38. HANSON, F. B., and E. STANTON. The effect of increasing x-ray voltage on the production of lethal mutations in *Drosophila melanogaster*. *Anat. Rec.* **44**: 293. 1929. (Abstr.)
39. HANSON, F. B., F. HEYS, and E. STANTON. The effects of increasing x-ray voltages on the production of lethal mutations in *Drosophila melanogaster*. *Amer. Nat.* **65**: 134-143. 1931.
40. HARRIS, B. B. The effects of aging X-rayed males upon mutation frequency in *Drosophila*. *Jour. Hered.* **20**: 299-302. 1929.
41. HERTWIG, G. Radiumbestrahlung unbefruchteter Froscheier und ihre Entwicklung nach Befruchtung mit normalen Spermien. *Arch. Mikros. Anat.* **77**: 165-209. 1911.
42. HERTWIG, O. Die Radiumkrankheit tierischer Keimzellen. *Arch. Mikros. Anat.* **77**: 1-164. 1911.
43. HOLTHUSEN, H., and C. ZWEIFEL. Einfluss der Quantengröße auf die biologische Wirkung verschiedener Strahlenqualitäten. II. *Strahlentherapie* **43**: 249-272. 1932.
44. HOLWECK, F. Essai d'interprétation énergétique de l'action des rayons K de l'aluminium sur les microbes. *Compt. Rend. Acad. Sci. [Paris]* **186**: 1318-1319. 1928.
45. HOLWECK, F. Étude énergétique de l'action biologique de diverses radiations. *Compt. Rend. Acad. Sci. [Paris]* **190**: 527-529. 1930.
46. HOLWECK, F., and A. LACASSAGNE. Étude de la radiosensibilité du *B. prodigiosus* aux rayons x mous. *Compt. Rend. Acad. Sci. [Paris]* **100**: 1101. 1929. (See also *Ibid.* **104**: 1221-1223. 1930; **107**: 120-123. 1931.)

47. HOLWECK, F., and A. LACASSAGNE. Actions des rayons α sur *Polytoma uvella*. Détermination des "cibles" correspondant aux principales lésions observées. *Compt. Rend. Soc. Biol. [Paris]* **107**: 812-814. 1931.
48. HOLWECK, F., and A. LACASSAGNE. Sur le mécanisme de l'action cyto-caustique des radiations. *Compt. Rend. Soc. Biol. [Paris]* **103**: 766-768. 1930.
49. HUETTNER, A. F. Maturation and fertilization in *Drosophila melanogaster*. *Jour. Morph. and Physiol.* **39**: 249-265. 1924.
50. JOLLOS, V. Studien zum Evolutionsproblem. I. Über die experimentelle Hervorrufung und Steigerung von Mutationen bei *Drosophila melanogaster*. *Biol. Zentralbl.* **50**: 542-554. 1930.
51. KULENKAMPFF, H. Vergleichende Untersuchungen über die Energie und die luft-ionisierende Wirkung von Röntgenstrahlen verschiedener Wellenlänge. *Ann. Phys.* **79**: 97-142. 1926. (See also *Ibid.* **80**: 261-278. 1926.)
52. LACASSAGNE, A. Action des rayons K de l'aluminium sur quelques microbes. *Compt. Rend. Acad. Sci. [Paris]* **186**: 1316-1317. 1928. (See also *Ibid.* **188**: 197-200. 1929.)
53. LACASSAGNE, A. Différence de l'action biologique provoquée dans le levures par diverses radiations. *Compt. Rend. Acad. Sci. [Paris]* **190**: 524-526. 1930.
54. LANGENDORFF, H. and M., and A. REUSS. Über die Wirkung von Röntgenstrahlen verschiedener Wellenlänge auf biologische Objekte. II. Strahlentherapie **46**: 289-292. 1933. [See also (a) IV. *Ibid.* **46**: 655-662. 1933.]
55. LUYET, B. J. The effects of ultra-violet, X-, and cathode rays on the spores of *Mucoraceae*. *Radiology* **18**: 1019-1022. 1932.
56. MACARTHUR, J. W., and E. W. LINDSTROM. Radium, cathode, and x-ray mutants. *Proc. Vth Intern. Cong. Genetics* **2**: 336. 1932.
57. MEDVEDEV, N. The production of mutations in *Drosophila melanogaster* by the combined influence of x-rays and salts of heavy metals. *Compt. Rend. Acad. Sci. USSR.* 1933.
58. MORGAN, T. H., C. B. BRIDGES, and A. H. STURTEVANT. The genetics of *Drosophila*. 262 p. M. Nijhoff; 's Gravenhage, 1925.
59. MULLER, H. J. The problem of genic modification. *Verhand. V. Intern. Kong. Vererb. Berlin* **1**: 234-260. 1927.
60. MULLER, H. J. Artificial transmutation of the gene. *Science* **66**: 84-87. 1927.
61. MULLER, H. J. The production of mutations by x-rays. *Proc. Nation. Acad. Sci.* **14**: 714-726. 1928.
62. MULLER, H. J. The measurement of gene mutation rate in *Drosophila*, its high variability, and its dependence upon temperature. *Genetics* **13**: 279-357. 1928.
63. MULLER, H. J. The effects of X-radiation on genes and chromosomes. *Science* **67**: 82-83. 1928.
64. MULLER, H. J. The method of evolution. *Sci. Monthly* **29**: 481-505. 1929.
65. MULLER, H. J. Radiation and genetics. *Amer. Nat.* **64**: 220-251. 1930.
66. MULLER, H. J. Further studies on the nature and cause of gene mutation. *Proc. Vth Intern. Cong. Genetics* **1**: 213-256. 1932.
67. MULLER, H. J., and E. ALTENBURG. The frequency of translocations produced by X-rays in *Drosophila*. *Genetics* **15**: 283-311. 1930. [See also *Anat. Rec.* **41**: 100. 1928. (Abstr.)]
68. MULLER, H. J. and E. ALTENBURG. The rate of change of hereditary factors in *Drosophila*. *Proc. Soc. Exp. Biol. and Med.* **17**: 10-14. 1919.
69. MULLER, H. J., and L. M. MOTT-SMITH. Evidence that natural radioactivity is inadequate to explain the frequency of 'Natural Mutations.' *Proc. Nation. Acad. Sci.* **16**: 277-285. 1930.
70. OLIVER, C. P. The effect of varying the duration of x-ray treatment upon the frequency of mutation. *Science* **71**: 44-46. 1930.

71. OLIVER, C. P. An analysis of the effect of varying the duration of x-ray treatment upon the frequency of mutations. *Zeitsch. Indukt. Abstamm. und Vererbungsl.* **61**: 447-488. 1932.
72. PACKARD, C. Effect of radium radiations on the development of *Chaetopterus*. *Biol. Bull.* **35**: 50-70. 1918.
73. PACKARD, C. The measurement of quantitative biological effects of X-rays. *Jour. Cancer Res.* **10**: 319-339. 1926. [*See also* (a) *Ibid.* **11**: 1-15, 282-292. 1927; (b) **12**: 60-72. 1928.]
74. PACKARD, C. The relation of wave-length to the death rate of *Drosophila* eggs. *Jour. Cancer Res.* **13**: 87-96. 1929.
75. PACKARD, C. The relation between division rate and the radiosensitivity of cells. *Jour. Cancer Res.* **14**: 359-369. 1930.
76. PACKARD, C. The biological effects of short radiations. *Quart. Rev. Biol.* **6**: 253-280. 1931.
77. PACKARD, C. The biological effectiveness of high-voltage and low-voltage x-rays. *Amer. Jour. Cancer* **16**: 1257-1274. 1932.
78. PAINTER, T. S. A cytological map of the x-chromosome of *Drosophila melanogaster*. *Science* **73**: 647-648. 1931.
79. PATTERSON, J. T. The effects of x-rays in producing mutation in the somatic cells of *Drosophila melanogaster*. *Science* **68**: 41-43. 1928.
80. PATTERSON, J. T. The production of mutations in somatic cells of *Drosophila melanogaster* by means of x-rays. *Jour. Exp. Zool.* **53**: 327-372. 1929.
81. PATTERSON, J. T. Continuous versus interrupted radiation and the rate of mutation in *Drosophila*. *Biol. Bull.* **61**: 133-138. 1931.
82. PATTERSON, J. T. Lethal mutations and deficiencies produced in the x-chromosome of *Drosophila melanogaster* by x-radiation. *Amer. Nat.* **66**: 193-206. 1932.
83. PATTERSON, J. T., and H. J. MULLER. Are "progressive" mutations produced by x-rays? *Genetics* **15**: 495-578. 1930.
84. PLOUGH, H. H., and P. T. IVES. New evidence of the production of mutations by high temperature, with a critique of the concept of directed mutations. *Proc. Vth Intern. Cong. Genetics* **2**: 156-158. 1932.
85. PLOUGH, H. H. and P. T. IVES. Mutations and somatic variations induced by high temperature in *Drosophila*. *Rec. Genet. Soc. America* **2**: 55. 1933.
86. STADLER, L. J. The rate of induced mutation in relation to dormancy, temperature, and dosage. *Anat. Rec.* **41**: 97. (Abst.) 1928.
87. STADLER, L. J. Some genetic effects of X-rays in plants. *Jour. Hered.* **21**: 2-19. 1930.
88. STADLER, L. J. On the genetic nature of induced mutations in plants. *Proc. Vth. Intern. Cong. Genetics* **1**: 274-294. 1932.
89. STUBBE, H. Untersuchungen über experimentelle Auslösung von Mutationen bei *Antirrhinum majus*. III. *Zeitsch. Indukt. Abstamm. und Vererbungsl.* **60**: 474-513. 1932. [*See also* (a) *Ibid.* **56**: 1-38. 1930.]
90. WEINSTEIN, A. The production of mutations and rearrangements of genes by X-rays. *Science* **67**: 376-377. 1928.
91. WOOD, F. C. Effect on tumors of radiation of different wave lengths. *Amer. Jour. Roentgenol. and Radium Therapy* **12**: 474-482. 1924.
92. WOOD, F. C. Further studies on the effectiveness of different wave-lengths of radiation. *Radiology* **5**: 199-205. 1925.
93. WYCKOFF, R. W. G. The killing of certain bacteria by X-rays. *Jour. Exp. Med.* **52**: 435-446. 1930. [*See also* (a) *Ibid.* **52**: 769-780. 1930.]
94. WYCKOFF, R. W. G. The killing of colon bacilli by ultraviolet light. *Jour. Gen. Physiol.* **15**: 351-361. 1932.

95. WYCKOFF, R. W. G., and B. J. LUYET. The effects of X-rays, cathode, and ultra-violet rays on yeast. *Jour. Radiol.* **17**: 3-7. 1931.
96. WYCKOFF, R. W. G., and T. M. RIVERS. The effect of cathode rays upon certain bacteria. *Jour. Exp. Med.* **51**: 921-932. 1930.
97. ZUPPINGER, A. Radiobiologische Untersuchungen an Ascariseiern. *Strahlentherapie* **28**: 639-758. 1928.

Manuscript received by the editor July, 1934.

SUBJECT INDEX

A

- Aberrations, chromosomal, in animals, 1167-1208
- Absorption, curves, interpretation of, 54; X-ray, 48, 52
- of energy, ionization, 307; by green leaves, 779, 841
- of infra-red, by chlorophyll, 843
- of light, by anthocyanins, 1116; by atoms, 15
- lines, theory of, 19
- quantum theory of, 1311
- of radiation, 263; by proteins, 305
- of salts, by roots, *in re* spectral regions, 778
- spectra, 258; of bacteria, 1130; of chloroplast pigments, 1027-1032; continua in, 18; of enzymes, 1153, 1158, 1159
- of ultra-violet, by plant tissues, 874; by proteins, 305
- in X-ray region, 22
- of X-rays and radium rays, by proteins, 307
- Activation, of ergosterol, by ultra-violet, 323; discovery of, 324; physical chemistry of, 327
- of molecules, 253, 256
- Adrenals, irradiation of, 505
- Age, radiation and, with bacteria, 1135; with fungi, 893, 902, 907
- Agglutinins, irradiation of, 367, 375
- Agriolimax, response to light, 594
- Air mass, definition of, 212
- Alexin, inactivation, by ultra-violet, 356; by X-rays and radium, 357
- irradiation *in vitro*, 355-364; theoretical aspects, 358
- irradiation *in vivo*, 371
- Alpha particles, biological effects of, 559-572; on macroscopic structures, 562; on cells and cell organs, 564
- ionization by, 559, 568
- Alpha particles, properties of, 559
- sources of, 560
- Alterations, induced chromosomal, 1281-1295
- Amoeba, response to light, 573
- Amphibia, regeneration, 437; effects of radium on, 438; effects of X-rays on, 438
- Anaphylaxis, 355, 370
- Anatomical effects, *in re* photoperiodism, 692
- Aneuploidy, in plants, 1281, 1291
- Ångström, defined, 13
- Anthocyanin, absorption bands of, 1116
- formation, 1113; carbohydrate and, 1110; environment and, 1112; radiation and, 1109-1118; temperature and, 1113; ultra-violet and, 878; visible spectrum and, 777
- light transmission of, 1116
- pigments, 1109-1118
- visible light and, 1110
- Antibodies, irradiation of, 364-370, 372-378
- Antigens, irradiation *in vitro*, bacterial, 353; protein, 354; tuberculin, 352; venoms, 344; Wasserman, 353
- Antirachitic vitamin, 324
- Antitoxins, 370, 376
- Arenicola, response to light, 587
- Arthropods, color vision of, 599; orientation of, 597; response to light of, 595
- Auxin, 1086

B

- Bacteria, effects of radiation on, 1119-1149; sunlight, 1120; ultra-violet, 1121; visible light, 1127; X-rays, 1135
- fluorescence of, 1139
- influence of pH in irradiation, 1128; of temperature, 1127

- Bacteria, mitogenetic radiation and, 929;
 as detectors, 929; as senders, 941
 photodynamic agents and, 1140
 photosynthesis in, 1042, 1050
 pigments of, 1032
 relative sensitivity to radiation, 1133
- Bacterial toxins, irradiation of, 347
- Bacteriochlorophyll, 1032
- Bacteriological media, effects of radiation, 1129
- Bacteriolysins, 366, 373
- Bacteriopurpurin, 1031
- Beer's law, 260
- Bergonié and Tribondeau, law of, 402, 411, 419, 421, 426, 429, 452
- Biological effects, and ionization, 87-122
- Black body, 135; absolute source, 140; brightness of, 141; emission, 126, 137, 139; laws, 135, 136, 138; radiation, 257
- Blackman reaction, 1032, 1040, 1041, 1043
- Blood cells, 633, 642, 644
- Blood pressure, 502
- Blood vessels, irradiation of, 481
- Body (general), irradiation of, 491
- Body system and organs, effects of irradiation of, 473-539
- Bone and cartilage, irradiation of, 509; teeth, 510
- Bud abscission, by X-rays, 976
- Bulbs, formation of, *in re* photoperiodism, 689
- Bunsen-Roscoe law, fungi and, 892; motor responses and, 575, 597
- C
- Calciferol, 323, 329-331
- Calcium, 647, 650; release by irradiation, 648, 650
- Carbohydrate, and anthocyanin formation, 1110
- Carbon arc, 184
- Carotenoids, accompanying chlorophyll, 1102
 influence of light on formation of, 1022
 optical properties of, 1029
 photosynthesis and, 1021
- Casparian rings, 830
- Chaetopoda, regeneration, 432; effects of radium on, 435; effects of X-rays on, 435
- Chain reactions, 268
- Charge, surface, 640
- Chemical change, measurement, in a photochemical process, 277
- Chemical kinetics, 266
- Chemiluminescence, 264
- Chlorophyll, addition compounds of, 1042; condition in chloroplast, 1093; content, *in re* photosynthesis, 1035; effects of ultra-violet on, 1099; fluorescence of, 1030, 1044, 1093; infra-red absorption and, 843; molar-extinction coefficient of, 1099; optical properties of, (leaves) 779-787, 1027-1030; photoactivity of, 1099; precursors of, 1018; role in photosynthesis, 1041; structure of, 1041; yellow pigments accompanying, 1102
- Chlorophyll formation, effects of, darkness on, 1097; light on, 1015-1021; light intensity on, 735, 745; radiation on, 1093-1108; ultra-violet on, 878; various factors on, 1101
 in etiolated plants, 1095
- Chlorophyllogen, 1096; in etiolated plants, 1097, 1098
- Chlorophylls, absorption spectra of, 1028
- Chloroplasts, condition of chlorophyll in, 1093
 effect of light, on shape of, 834; on formation of pigments in, 1015-1022
- Chromosomal aberration, *vs* mutation, 1263
- Chromosomal alterations, induced, in maize, 1297-1310; in other plants, 1281-1295
 nature of, 1304
- Chromosomal breakages, and gene changes, 1192; maps, 1182; and mutations, 1221
- Chromosomal deficiencies, 1299
- Chromosomal interchanges, 1302
- Chromosomal inversions, 1297
- Chromosomal rearrangements, 1167, 1169; detection of, 1172, 1182; origin of, 1176
- Chromosomes, compounding, 1169; fragmentation, 1169
 influence of X-rays on disjunction of, 1170
 in maize, normal, 1297

- Chromosomes, in salivary glands, 1189
- Ciliates, response to light, 581
- Cleavage, effects of irradiation on, 394
- Coagulation, of proteins by irradiation, 319
- Coefficient, defined, of correlation, 246; of variation, 238
- Coelenterates, response to light, 586
- Colloids, protoplasmic, 643 (*see* Protoplasm)
- Colonial forms, response to light, 582
- Color vision, of *Daphnia*, 599; of insects, 611
- Competitive pairing, 1199
- Composition of plants, as affected by light, 732
in re regions of spectrum, 771
- Compton effect, 39, 101
- Corpuscles, and waves, 2
- Crossing over, cytological demonstration of, 1190; in rearrangements, 1198
- Crown gall, inhibition of, by radium, 996
- Curve fitting, 244-250; exponential, 247, 248; straight line, 246
- Cytological maps, 1182
- Cytology, of green plants, effects of X-rays, 978
- Cytolysis, by ultra-violet, 649; by visible light, 644
- Cytoplasm, *in re* irradiation, 1283; sensitivity of, 627
- D
- Dark-growth response, 1075
- Darkness, anatomical effects (plants), 830
effects on plants, 727; composition, 732; growth, form, and structure, 728; nitrate utilization, 736; stem elongation, 737
- Day-length, as ecological factor, 706
- Death, cause of, in irradiation, 1317
- Deficiencies, chromosomal, 1170, 1175, 1195; detection of, 1172
in maize, 1299; internal, 1301; ring chromosomes, 1301; terminal, 1299
in re irradiation, 1292
- Denaturation, of proteins by radiation, 310, 314
- Deradiation response, 999
- Detectors, absolute, 142
in mitogenetic radiation, bacteria, 929; onion root tips, 922; yeasts, 924
selective, 190; black body plus filter, 191; photochemical, 197; photoelectric, 193-197
special, infra-red, 205; ultra-violet, 201; visibility, 200
- Deviation, defined, average, 233; standard, 233
- Diffugia, response to light, 574
- Diffraction, 8-10
- Dissociation, heat of, 273
of molecules, 255
- Dormancy, *in re* photoperiodism, 691
- Dosage, X-ray, *in re* mutational effect, 1238
- Dosimeters (X-ray), calibration of, 68
- Duplication, chromosomal, 1170, 1175; changes of genes in, 1195; detection of, 1172
- E
- Ear, irradiation of, 506
- Earthworms, response to light, 588
- Einstein's law, 261
- Electric waves (short), in biology, 541-558; apparatus for, 550; biological effects, 543; heat effects, 544; other effects, 546; synthetic fever by, 545
- Electron pairs, 4
photons and, transmutation between, 41
- Electrons, of internal orbits, 23
photons and, 1-42
- Electrostatic fields, (*see* Electric waves)
- Embryonic cells, susceptibility, to radium, 411
to X-rays, 411
- Embryonic development, differential sensitivity in, 401
effects of radiation on, 389-410; cleavage, 394; fertilization, 391; gastrulation, 396; later stages, 397
- Emission, of light, 24
black body, 126, 137, 139
continuous, sources of, carbon arc, 184; sun, 171; tungsten filament, 180
selective, sources of, 184
spectra, optical, 28; X-ray, 24
- Emulsoids, 303; effects of radiation on, 309

- Endodermis, effect of light on, 830
 Energy, between atoms, 255
 Energy relations, in photosynthesis, 1045; photosynthetic efficiency, 1045
 Environmental factors, and day-length, 697
 Enzymes, absorption spectra, 1153, 1158, 1159
 crystalline, 1158, 1159
 irradiation of, 1151-1165 with monochromatic light, 1154; with sunlight, 1151; with ultra-violet, 1154
 Epidermis, effect of ultra-violet on, 834-838
 Ergosterol, 323, 330
 absorption of radiation by, 326
 activation (irradiation), 323; discovery of, 324; factors affecting, 328; physical chemistry of, 327; products of, 329; temperature coefficient of, 328
 Erythema system, units, 204
 Etiolation, 734, 830; theories regarding, 738; value to plant, 739
 Euglena, response to light, 578
 Eye, irradiation of, 505
 Eye colors, dominant, 1193
 Eye spots, function of, 579, 583
- F
- Fasciation, of green plants, by X-rays, 974, 976
 Fat, freed by irradiation, 655
 Fermentation, effects of, radiation on, 904, 1059-1072; ultra-violet light on, 1068; visible light on, 1068; X-rays on, 1070
 in fungi, 904, 905, 908
 heat effects in, 1070
 Fertilization, effects of radiation on, 391
 Filters, 159-170, 276; Christiansen, 164, 167, 168; colored, *in re* growth of seed plants, 763; heat-absorbing, 162; monochromatic, 164, 165; short-wave cut-off, 159, 160; water, 163
 Filtration, of gamma rays, 105; of X-rays, 104
 Flagellates, response to light, 578
 Flower formation, effects of ultra-violet on, 877; light intensity on, 752
 Flower and fruit development, effects of X-rays, 976
 Flowering and fruiting, *in re* photoperiodism, 685
 Fluorescence, 31-36, 265; of bacteria, 1139; of chlorophyll, 1030; of plant parts under ultra-violet, 876
 Fragmentation, chromosomal, 1169, 1182
 in re irradiation, 1282-1284, 1291, 1292
 Frequencies, 7, 13
 Fresnel's law, 260
 Fruiting, in fungi, 895
 Fungi, effects of radiation on, 889-918; form of fruiting structures, 895, 905, 907; growth rate, 890, 897; mycelium, 889; pigmentation, 889; saltations, 903, 906; spore discharge, 901; spore germination, 901, 908; spore production, 898, 908; zonation, 895
 effects of radium on, 907; ultra-violet on, 889; X-rays on, 904
 Fusion, *in re* irradiation, 1283, 1284, 1291
- G
- Gamma ray spectrum, 15
 Gamma rays, filtration of, 105; ionization of air by, 114
 Gastro-intestinal tract, irradiation of, 494; colon, 499; esophagus, 495; gall bladder, 500; liver, 500; pancreas, 499; salivary glands, 495; small intestine, 496; stomach, 496; upper portions, 494
 Gastrulation, effects of radiation on, 396
 Geiger-Müller counter, 921, 935
 Gelation, of protoplasm, 649
 Gene, distribution, 1311; number, 1321; size, 1323; mutations, 1282, 1292
 Gene changes, and chromosomal breakages, 1192
 Genetic maps, 1182
 Germination (seeds, fruits), effects of visible spectrum on, 791-827; conditions modifying, 793; dosage, 817; historical, 791; regions of spectrum concerned, 815; seeds favorably affected, 793, 796; seeds inhibited, 811, 814, 815; theories of action, 818
 of fungus spores, 901, 908
 of seeds, *in re* ultra-violet, 853; *in re* X-rays, 963

- Gesneriaceae, effects of light on germination, 796
- Glass, ultra-violet transmitting, 869
- Gonadal system, irradiation of, 517; ovary, 517; testis, 517
- Grenz rays, 79
- Growth (and development), in plants, in continuous illumination, 715-725; with supplemental and artificial illumination, 717
- effects of light intensity on, 728, 735, 737, 743
- in re* regions of spectrum, 764
- in re* ultra-violet, 853, 860
- in re* ultra-violet transmitting glass, 869
- Growth movements, 1073-1091 (*see* Phototropism); effects of X-rays on, 972
- Growth rate, of fungi, 890, 897; light intensity and, 1076; wave-length and, 1076
- Growth relations, *in re* photoperiodism, 687
- Growth-response, to radium, 999
- Growth substance, 1083
- Gurwitsch phenomenon, 921
- Gynandromorphs, induction of, 1171
- H
- Haploidy, 1281, 1288
- Heart, irradiation of, 501
- Heat, of reaction, 254
- Helix, response to light, 594
- Hematopoietic system, effects of irradiation on, 511; bone marrow, 513; coagulating power, 515; foreign-body reaction, 515; red blood cells, 512; reticulo-endothelial system, 515; sedimentation rate, 516; spleen and lymph nodes, 511; white blood cells, 512
- introduction of radioactive material into, 516
- Hemolysins, 364, 372
- Heredity, in plants, effects of irradiation on, 1004 and photoperiodic response, 701
- Hertzian waves, 14
- High voltage, equivalent, 49, 58; rectifiers, 44; wave form, effect of, 47
- H-ion concentration, effects on irradiation of bacteria, 1128; of enzymes, 1154; 1156, 1158, 1159
- Histological effects (plants), of darkness, 830; of light on tissues, 829; of regions of visible spectrum, 831-834; of ultra-violet, 834-838; of X-rays, 977
- Huygens' principle, 4
- Hydrozoa, regeneration, 413; effects of radium on, 419; effects of X-rays on, 415
- I
- Illumination, artificial, and day-length, 695, 700
- Induction, photoperiodic, 694
- Induction period, 271
- Infra-red, 14; chemical reactions and, 257
- effect on photosynthesis, 1038
- green plants and, 841-852; injury from, 849; transpiration effects, 846
- Inhibitors, photosynthesis and, 1034
- Insects, response to light, 599
- Intensity, of radiation, 96; effective, 110
- distribution, and wave-length, 153
- of total solar radiation, on horizontal surface, 212; seasonal variations by weekly averages, 216, 217; daily variations by hourly averages, 219-221; effect of cloudiness, 223, 224; variations with geographical position, 223
- Interchanges, chromosomal, in maize, 1302
- Intestinal tract, 494 (*See also* Gastro-intestinal tract)
- Inverse square law, 96
- Inversion, chromosomal, 1170; in maize, 1297-1310
- Invertebrates, response to light, 573-623
- Ionization, by alpha particles, 559, 568
- biological effects and, 87-122
- energy absorption and, 307
- fundamental character of, 87
- importance in irradiated organism, 115
- by light, 18
- significance of measurements of, 111
- by X-rays, 46
- Ionization chambers, calibration of, 68, 74

- Ionization chambers, secondary, 73
 standard, 63, 67, 69
- Ionization currents (X-ray), measurement of, 71
- Ions, distribution in ionized medium, 90;
 influence of quality on, 94
 recombination, 88
- K
- Kidney, irradiation of, 504; bladder, 499
- Kinetics, chemical, 266; photochemical, 269
- L
- Lambert's law, 260
- Laws, photochemical, 259
- Leaves, of green plants, effects of X-rays on, 973
 optical properties of, 779, 1022
- Lethal dose, statistical treatment of, 241
- Leucophyll, 1095, 1098
- Light, artificial, effects on seed plants, 867; growth, 717; structure, 720
- Light, effects on, permeability, 739, 742;
 root development, 733, 736, 744; use of food reserves in plants, 731
 mechanical equivalent of, 133
 of optical spectrum, production of, 28-36; electrical means, 28; optical means, 31
- Light, visible, anthocyanin and, 1110;
 chlorophyll development and, 1093;
 measurement of, 123-209; sensitization of proteins to, 313
 effects on, bacteria, 1127; enzymes, 1151; fermentation, 1068; fungi, 889; permeability of protoplasm, 628, 644; plant tissues (histological), 829, 831; respiration, 1059; seed plants, 763; seed germination, 791
- Light-growth reaction, 740
- Light-growth responses, 1074 (*see* Phototropism)
- Light intensities, effects on, chemical reactions, 274; chlorophyll development, 735, 745; etiolated plants, 734; flowering, 752; growth and development, 743; "light-growth" reaction, 740; mineral nutrition, 750; minimum requirements, 754; resistance to drought, 754; seed plants, 727; transpiration, 752; winter hardiness, 754
 measurement of, 276
- Light periods, abnormal, *in re* photoperiodism, 700
- Light sources, 171, 184, 276
- Limax, response to light, 594
- Lithophane units, 838
- Long-day and short-day plants, definition of, 683
- Loranthaceae, effects of light on germination, 793
- Lumisterol, 329, 330
- Lungs and heart, irradiation of, 501
- Lythrum, effects of light on germination, 809
- M
- Maize, induced chromosomal alterations in, 1297-1310
- Maps, cytological and genetic, 1182
- Matter, influence of, on radiation intensity, 99; on radiation quality, 100, 104
- Matter and radiation, interaction of, 93; secondary phenomena, 101
- Maxwell-Boltzmann, distribution law, 254
- Mean, arithmetic, computation of, 234; defined, 233
- Measurements, of irradiation effects, statistical treatment of, 232
- Median, defined, 233
- Mercury arc, 154, 185-187; plus filter, 166
- Mitogenetic radiation, 919-959; bacteria as detectors of, 929; biological materials and, 930; characteristics of, 920; earlier experiments, 921; mycetoerit technique in, 927; onion root tips as detector of, 922; physical methods in, 933; physical properties of, 936; secondary radiation in, 932; yeast as detectors of, 932
- Mode, defined, 233
- Molluses, response to light, 592
- Monochromatic, irradiation of materials, 158; measurements, 149
- Monochromatic light, wave-length measurement of, 8

- Monochromators, 276
 Monosomics, 1281, 1290
 Morphological effects, *in re* photoperiodism, 692
 Morphology, of fungi, *in re* irradiation, 895, 908
 of green plants, *in re* X-rays, 973
 Motor responses, to light, in invertebrate animals, 573-623
 Muscles, irradiation of, 518
 Mutability, *in re* irradiation, species differences, 1270
 Mutation (in animals), 1209-1261; and chromosomal breakage, 1221; characteristics of the process, 1213; "group effects" in, 1225; lethal mutation rate, 1229; localized occurrence, 1219; nature of process, 1250; "position effect" and, 1222; quantitative study of, 1211; rate, 1227; rate in different tissues, 1230; rates at different loci, 1213; relation between lethal and viable, 1227; spontaneous, causes of, 1248; stability in an allelomorphie series, 1216
 Mutation, *in re* irradiation (in animals), 1209-1261; "direct effects," 1246; discovery of effect, 1210; induced changes of susceptibility, 1244; intensity relations, 1238; mode of action, 1236; quantum theory of absorptions, 1311; time factor, secondary reactions, 1243; wavelength dependence, 1241
 Mutation (in plants), *vs* chromosomal aberrations, 1263; effective radiations, 1268; effects of radium rays on, 1004; gene, 1282; induced by radiation, 1263
 Mya, response to light, 592
 Mycotoxigenic technique, in mitogenetic radiation, 927
- N
- Nemertina, regeneration in, 430
 effects of X-rays on, 430
 Neon lamps, effects on green plants, 722
 Nerve tissue, irradiation of, 507
 Nondisjunction, 1171
 Nucleus, sensitivity of, to irradiation, 627, 1312
 Nutrient medium, radiation and, with fungi, 893, 902, 906-909; with bacteria, 1129
 Nutrition, mineral, and light intensity, 750
- O
- Onagraceae, effects of light on germination, 806
 Onion root tips, in mitogenetic radiation, as detectors, 922
 Oscillator, half-wave, 555; push-pull, 554
- P
- Peeten, response to light, 593
 Percentages, statistical treatment of, 227
 Permeability, cellular, effect of visible light on, 628, 644; of radium, 634; of X-rays on, 637; of ultra-violet on, 633
 pH (*see* H-ion concentration)
 Phacelia, effects of light on germination, 811
 Phosphorescence, 36; effects of radiation on, in fungi, 909
 Photocatalyst, 270
 Photocell, 194, 196
 Photochemical, calculations, 280
 factors, effects of, 271
 kinetics, 269
 phenomena, 263
 reactions, 282; acetone, 282; acetylene, 282; aldehydes, 283; ammonia, 284; anthracene polymerization, 284; bromination of cinnamic acid, 286; bromine-hydrogen, 287; chlorination of benzene, 287; chlorination of trichlorobromo-methane, 291; chlorination of tetrachloroethylene, 288; chlorine-hydrogen combination, 289; Eder's reaction, 291; fulgides, 291; fumaric maleic acid isomerization, 292; hydriodic acid, 293; hydrogen peroxide, 292; impurities and, 275; intensity and, 274; iodine and ferrous ion, 294; laws, 259; mercury vapor, 294; monochloro-acetic acid hydrolysis, 294; nitrate ion, 296; nitrogen dioxide, 294; nitrogen pentoxide,

- 295; oxalic acid sensitized by uranyl ion, 297; oxidation of ions by dissolved oxygen, 296; ozone, 298; persulfate ion, 299
- technique, 275
- temperature and, 271
- theory of, 253
- wave-length and, 272
- Photochemistry, 253-302
- Photodynamic agents, effects of, on irradiation of, bacteria, 1140; enzymes, 1155, 1157; organic products, 346, 347, 356
- Photoelectric effect, of metals, 10
- Photon energy, measurement of, 10
- Photons, 1, 256; electrons and, 1-42
- Photoperiodic aftereffect, in plants, 694
- Photoperiodism, 677-713; discovery of, 679
- Photosynthesis, bacteria and, 1050; chemical inhibitors and, 1034; compensation point of, 1037; energy relations of, 1045; energy transfer in, 1049
- effect of, chlorophyll content, 1035; changes in illumination, 1037; previous treatment of plants, 1036; temperature, 1034; light intensity, 1032
- efficiency of photosynthetic reaction, 1045, 1046
- inhibition by high light intensities, 1033
- in intermittent light, 1043
- internal factors in, 1035
- light factor in, 1015-1058
- light intensity utilizable in, 1038
- mechanism of, 1040
- possibility of, in infra-red, 843
- quanta used in, 1047
- rates of, effect of wave-length, 1038; infra-red, 1038; ultra-violet, 1039; visible light, 1039
- reactions in, mechanism of, 1040
- wave-length limits of, 1040
- Phototropism, 1073-1091
- dark-growth response, 1075
- growth substance, 1083
- light intensity and, 1076; sensitivity, 1081; wave-length, 1076
- light-growth response, 1074
- Physical properties, mitogenetic radiation, 936
- Physiological properties, 904, 908
- Physiological responses, in plants, to radium, 995
- Pigmentation, protective action of, on fungi, 889, 902
- Pigments, anthocyanin, 1109; chloroplast, 1015, 1021
- Planck's constant, 262, 280
- Poa, effects of light on germination, 801
- Polonium, as source of alpha particles, 561
- Ploidy, 1281, 1288, 1289
- Polysomics, 1281, 1290
- Porifera, regeneration of, 412
- effects of X-rays on reunion in, 413
- Position effects, in chromosomes, 1196
- Precipitin, effect of irradiation on, 367, 375
- Proteins, absorption of radiation by, 305, 307
- coagulation of, by radiation, 318
- denaturation, by irradiation, 310, 314
- effect of, radiation on, 303-322; ultra-violet on, 305, 310; X-rays and radium on, 307, 314
- isoelectric points, 304
- primary and secondary light reactions, 316
- sensitization to visible light, 313
- Protochlorophyll, 1096
- Protoplasm, effects of radiation on, 625-676
- permeability of, *in re* radium, 634, 643; X-rays, 637; ultra-violet, 633; visible light, 628
- viscosity of, 643; *in re* X-rays and radium, 650; ultra-violet, 645; visible light, 644
- Provitamin D, 325, 326
- Pyrheliometry, standard of, 211

Q

- Quantum action, probability theory, 1312, 1313, 1316; single absorption, 1313; multiple absorptions, 1313
- Quantum-hit theory, fungi and, 892; bacteria and, 1138
- Quantum theory, 261
- of absorptions, biological aspects, 1311-1330

Quantum yield, calculation of, 280;
interpretation of, 281
Quartile limits, defined, 233

R

Radiation, effective quantity of, 117;
effective intensity of, 110; influence
of matter on intensity of, 99; ions in
living matter and, 94
intensity, and inverse square law, 96
matter and, interaction of, 93; second-
ary phenomena, 101
sources of (*see* Black body), arc and
spark, 189, 190; carbon arc, 184;
commercial lamps, 183; helium
plus filter, 167; hydrogen plus
filter, 167; mercury arc, 154, 185-
187; mercury arc plus filter, 166;
sun, 171-180 (*See also* Solar
radiation); tungsten (radiance of),
137, (properties of) 181
types of, 257

Radio waves (short) (*see* Electric waves)
Radiometers, 145

Radium, biological effects, qualitative,
459; quantitative, 461
effects on, chromosomal alternations,
1284, 1290; cleavage, 395; differ-
ential sensitivity in development,
401; embryonic development, 389-
410; fermentation, 988; fertiliza-
tion, 391; fungi, 907; gastrulation,
396; growth-response, 999; hered-
ity, 1004; mutation, 1263-1280;
permeability of protoplasm, 634;
physiological responses, 995;
plants, 987-1013; proteins, 307,
314; respiration, 988, 1001, 1065;
viscosity of protoplasm, 650

"fertilizers," 991

measurement, 1, 81

regeneration effects, 411-457 (*See also*
Regeneration)

units of intensity, 990

wave-length dependence of, 459; test
objects, 463

Radon, as source of alpha particles, 560

Raman effect, 37

Ranunculus, effects of light on germina-
tion of, 805

Reaction, surface participation, 648, 654

Reactions, photochemical, 253, 282 (*see*
Photochemical reactions)

Reflection, of light, by leaves, 779
of ultra-violet, by plant tissues, 874

Reflectors, 170

Refraction, 4

Regeneration, effects of radium, in
Amphibia, 438; in Chaetopoda, 435;
in Hydrozoa, 419; in Tunicata, 437;
in Turbellaria, 421

effects of X-rays, in Amphibia, 437; in
Chaetopoda, 435; in Hydrozoa,
415; in Nemertina, 430; in Porifera,
412; in Turbellaria, 419

effects of X-rays and radium on, 411-
457

physiological, as affected by X-rays
and radium, 450

Resonance radiation, 32

Respiration, effects of radiation on, in
fungi, 904, 908; in plants, 1059-1072
effects of radium on, 1065; ultra-violet
on, 1062; visible light on, 1059;
X-rays on, 972, 1063

Responses, of invertebrates to light, 573-
623

in re photoperiodism, 677

in re phototropism, 1074

of plants, to radium, 995

Reticulo-endothelial system, irradiation
of, 481

Rhizopods, response to light, 573

Roentgen, definition of, 62; measurement
of, 66

rays (*see* X-rays)

Roentgenometers, 68

Root development, effect of, light on,
733, 736, 744; X-rays on, 968

formation, *in re* photoperiodism, 689

S

Saltations, in fungi, 903, 906

Salts, protective action of, in irradiation,
1155

Sampling error, of frequency constants,
237; of a percentage, 229

Saponins, irradiation of, 345

Scattering, of light, with change of
frequency, 37; without change of
frequency, 36

of X-rays, 39

- Schumann region, 15
- Screens, colored, *in re* growth of seed plants, 763 (*see* Filters)
- Seed, effect of light on utilization of food, 731
- germination (*see* Germination), effects of, ultra-violet on, 853; X-rays on, 963
- plants, under artificial illumination, 867; daylight minus ultra-violet, 863; ultra-violet, 853-887
- Seedlings, *in re* ultra-violet, 853
- Segmental interchange, 1169, 1177
- Self-reversal, in emission spectra, 30, 31
- Senders, of mitogenetic radiation, 940; bacteria as, 922, 941; onion root tips as, 922; yeast as, 941
- Senescence, *in re* photoperiodism, 691
- Sensitive spot hypothesis, 1312, 1317-1323; gene number, 1321, 1322; gene size, 1323; mechanism of action, 1317, 1320
- Sensitivity, to irradiation, of bacteria, 1133; biological variation of, 1316, 1325; significance of variation of, 1324; in embryonic development, 401
- of plants, to radium, 993; to X-rays, 970
- in phototropism, 1081; base response to light, 1081; tip response to light, 1081
- Skin, irradiation of, 477
- Solar radiation, 126, 171-180, 211-226
- intensity, at normal incidence, 212
- intensity variations, with air mass, 213, 215; with altitude, 213; with seasons of year, 214; with geographical position, 222, 223
- pyrheliometric standard of, 211
- Spark lines, 31
- Spectra, band, 258; types of, 258; continuous, discontinuous, 273
- Spectral analysis, mitogenetic, 938
- Spectral regions (visible), absorption, etc., by leaves, 779
- effects on, seed plants, 763-790; absorption of inorganic salts, 778; anthocyanin formation, 777; chemical composition, 771; growth and development, 764; stomatal behavior, 775; transpiration, 773
- Spectrum, gamma ray, 15; regions of, 14
- Spores, of fungi, 898, 908
- Standard deviation, defined, 233; of difference, 230, 237; of frequency constants, 238; of point binomial, 229
- Standard error, of coefficient of variation, 238; of mean, 237; of standard deviation, 237
- Stationary states, 16-19
- Statistical treatment, of irradiation problems, 227
- Stele, effect of light on, 830, 832
- Stems, of green plants, effects of X-rays on, 974
- Stentor, response to light, 581
- Sterols, activation of, 324, 333
- Stimulation, mitogenetic, 919
- radiation and, with fungi, 893, 899, 905, 908
- by radium rays, 995
- by X-rays, with green plants, 962-968
- Stokes' law, 33
- Stomatal behavior, *in re* regions of spectrum, 775
- Structure, of plants, and light intensity, 728
- Sun, 171 (*See also* Solar radiation); luminous equivalent of energy, 180; spectral distribution from, 126, 174, 175; total radiation, variability of, 172, 173; ultra-violet radiation from, 176, 177, 179
- Sunlight, continuous, effects on green plants, 715, 722
- effects on bacteria, 1120
- Suprasterol, 330, 332
- Survival curves, fungi and, 891-893, 905-907
- Suspensoids, 303; irradiation and, 308

T

- Tachysterol, 329-331
- Temperature, anthocyanin formation and, 1113; photochemical reactions and, 271
- radiation and, with fungi, 893, 894, 900, 903
- Temperature coefficient, 268; of ultra-violet inactivation of bacteria, 1128

- Terms, 21
- Tetraploids, *in re* irradiation, 1288, 1289
- Thermocouple technique, 144
- Thermopiles, 277
- Toxins, bacterial, *in vitro* irradiation, 347
- Toxisterol, 330, 332
- Translocations, chromosomal, 1284, 1291; reciprocal, 1169, 1178; simple, 1169, 1178
- Transmission, by leaves, of spectral regions, 779
of ultra-violet, by glass screens, 869
- Transmutation, by X-rays, in plants, 1273
- Transpiration, effects of, light intensity on, 752; radiation on, in fungi, 904
of green plants, in infra-red, 846
by leaves, *in re* regions of spectrum, 773
- Triploids, *in re* irradiation, 1288, 1289
- Trisomics, *in re* irradiation, 1290
- Tropisms, in fungi, *in re* radium, 909
(*See* Motor responses and Phototropism)
in response to radium, 994, 999
- Tubers, formation, *in re* photoperiodism, 689
- Tubicolous annelids, response to light, 587
- Tungsten, properties of, 181; radiance, 137
- Tungsten filament, radiation source, 180
- Tunicata, regeneration of, 436; effects of radium on, 437
- Turbellaria, regeneration of, 419; effects of radium on, 421; effects of X-rays on, 419
response to light, 590
- U
- Ultra-violet, 15
absorption, by bacteria, 1130; by enzymes, 1153, 1158; by proteins, 305; and reflection, by plant tissues, 874
anthocyanin formation and, 878, 1114
chemical reactions and, 257
daylight-lacking, effects on seed plants, 863
effects on, anatomical structure, 877; bacteria, 1121; chlorophyll, 878, 1099; emulsoids, 310; enzymes, 1152; fermentation, 1068; flower formation, 877; fungi, 889; germination, 853; mature plants, 860; media, 1129; permeability of protoplasm, 633, 645; photosynthesis, 1039; plant tissues, 829, 834; proteins, 305, 310; respiration, 1062; seed plants, 853-887; suspensoids, 308
ergosterol, irradiation with, 323
fluorescence of plant parts and, 876
measurement of, 123, 192, 197, 201; from the sun, 176-179
mitogenetic source of, 919, 920
phenomena, 201
plus daylight, effects on seed plants, 864
short wave, effects on seed plants, 861
special glass transmitting, 869
of sunlight, 176
- Units, 131; Å, wave-length, etc., 13; measurements and, 130
- V
- Vacuolization, 649, 654, 657
- Venoms, irradiation *in vitro*, 342; *in vivo*, 376-377
- Visibility, relative, 132; maximum absolute, 133; sensitivity curve of, 200
- Visible light (*see* Light, visible)
- Vision, of *Daphnia*, 599; of insects, 610; sensitivity curve of, 200
- Vitamin, antirachitic, 324
- Vitamin D, 323, 324, 329-331; multiple nature of, 326, 333; origin in nature; 333; production, from ergosterol, 323
- Vitamins, and radiation, 323-340
- Volvox, response to light, 582
- W
- Water, transmission, 163; transmissive exponents, 126
- Wave-length, effect on photosynthesis, 1038
and intensity distribution, of radiation, 153
mitogenetic radiation and, 919, 938
monochromatic measurement of, 8
photochemical influence of, 272
units of, 13
of X-rays, biological dependence, 459

Wave-length, of X-rays, effectiveness, 459-471; qualitative, 459; quantitative, 461
 of X-rays, *in re* mutation, 1241
 Waves, and corpuscles, 2
 Winter hardiness, effects of light intensity on, 754
 Worms, response to light, 587

X

X-ray, absorption curve, 48; standard absorption curves, 52
 dosimeters, calibration of, 68
 effects of voltage wave form, 47
 generators, high voltage, 44
 ionization chambers, 63, 67, 69, 73
 ionization currents, measurement of, 71
 low and high voltage, measurement of, 79
 measurement of, 62
 output, measurement of, 78
 production, 43
 quality, measurement of, 45, 66; secondary methods of expressing, 59
 quantity, international definition of, 62
 spectral distribution, 46
 standards adopted, 65
 tubes, 43, 67
 X-rays, 15; absorption, 22
 "back scatter," 102
 biological effects (qualitative), 459; (quantitative), 461
 chemical reactions and, 257
 and chromosomal alterations in maize, 1298; deficiencies, 1299; interchanges, 1302; inversions, 1298; nature of alterations, 1307
 and chromosomal alterations, in plants, 1282-1284, 1289, 1291
 degeneration of, 101
 distribution of ions in living matter, 94

X-rays, effective intensity of, 110
 effective quantity of, 117
 effects on, bacteria, 1135; cleavage, 394; differential sensitivity in embryonic development, 401, (later stages) 397; fermentation, 1070; fertilization, 389; fungi, 904; gastrulation, 396
 effects on, green plants, 961-985; cytology, 978; flower and fruit development, 976; germination, 963; histology, 977; morphology, 973; physiology, 962; respiration, 972, 1063
 emission spectra of, 24
 filtration of, 104
 influence of matter, on the intensity of, 99; on the quality of, 100
 intensity of and inverse square law, 96
in re mutation (in animals), 1209; "direct effects," 1246; discovery of effect, 1210; induced changes of susceptibility, 1244; intensity relations, 1238; mode of action, 1236; time factor, secondary reactions, 1243; wave-length dependence, 1241
in re mutation (in plants), 1263-1280; nature of transmutation, 1273
 production of, 25
 in protein irradiation, 307, 314
 regeneration effects, 411-457 (*see* Regeneration)
 scattering, 39
 wave-length dependence of, 459

Y

Yeast in mitogenetic radiation, as detectors, 924; as senders, 941

Z

Zonation, in fungi, 895

ALPHABETICAL LIST OF CONTRIBUTORS

Anderson, E. G., 1297-1310
Arthur, John M., 715-725, 841-852, 1109-1118
Bills, Charles E., 323-340
Brackett, F. S., 123-209
Brooks, S. C., 341-388
Brown, F., 763-790, 853-887
Buchholz, J. T., 829-840
Butler, Elmer G., 389-410
Clark, Janet Howell, 303-322
Crocker, William, 791-827
Curtis, W. C., 411-457
Daniels, Farrington, 253-302
Darrow, Karl K., 1-42
Dobzhansky, Theodosius, 1167-1208
Duggar, B. M., 1119-1149
Failla, G., 87-122
Gager, C. Stuart, 987-1013
Garner, W. W., 677-713
Goodspeed, T. H., 1281-1295
Gowen, John W., 1311-1330
Hand, Irving F., 211-226
Heilbrunn, L. V., 625-676
Hollaender, Alexander, 919-959
Inman, O. L., 1093-1108
Johnson, Edna L., 961-985
Johnston, Earl S., 1073-1091
Kettering, C. F., 1093-1108
Kimball, Herbert H., 211-226
Lyon, Charles J., 1059-1072
Mast, S. O., 573-623
Mazia, Daniel, 625-676
McKinley, G. Murray, 541-558
Packard, Charles, 459-471
Popp, H. W., 763-790, 853-887
Reed, Lowell J., 227-251
Rothmund, Paul, 1093-1108
Schomer, Harold A., 1151-1165
Schultz, Jack, 1209-1261
Shirley, Hardy L., 727-762.
Smith, Elizabeth C., 889-918
Smith, J. H. C., 1015-1058
Spoehr, H. A., 1015-1058
Stadler, L. J., 1263-1280
Taylor, Lauriston S., 43-85
Warren, Stafford L., 473-539
Zirkle, R. E., 559-572

Vol. I contains pp. 1-676; Vol. II, pp. 677-1330.





