

No.



THE BOOK OF PHOTOGRAPHY

THE BOOK OF PHOTOGRAPHY

PRACTICAL, THEORETICAL,
AND APPLIED

EDITED BY

PAUL N. HASLUCK

Author of "The Book of Photography,"
"The Book of Photography," "The Book of Photography,"

Author of "The Book of Photography,"
"The Book of Photography," "The Book of Photography,"

Author of "The Book of Photography,"
"The Book of Photography," "The Book of Photography,"

ILLUSTRATED WITH

FORTY-EIGHT FULL-PAGE PLATES AND NUMEROUS ENGRAVINGS
AND WORKING DRAWINGS

CASELL AND COMPANY, LIMITED
LONDON, PARIS, NEW YORK & MELBOURNE. MCMV

ALL RIGHTS RESERVED

939

P R E F A C E.

THE BOOK OF PHOTOGRAPHY has been prepared at the request of many readers of my smaller books on the subject who have expressed a wish for a comprehensive treatise. My own practice in Photography dates back to the time when the operator prepared each plate for his own use; first by a tedious process of cleaning the glass, next by dexterously flooding it with collodion, and finally by sensitising it in a bath of silver nitrate. My first photographs, some of which I still possess, were taken with apparatus wholly my own construction, which served its purpose quite satisfactorily for many years.

In planning this present Book I sought the assistance of Mr. Arthur Hands, who has long been a regular contributor to one of the journals it is my fortune to edit. He has written a large portion of the matter contained in the following pages, and has read most of the proofs. Other well-qualified experts in Photography have contributed certain sections, and I would particularly mention Mr. Theodore Brown; Mr. F. Martin Duncan; Mr. T. C. Hepworth; Mr. A. Lockett (a voluminous writer, who has also read all the pages for press); Mr. E. Smith; Mr. H. B. Stocks; Mr. F. H. Streatfeild; and Mr. E. J. Wall. I am also indebted to The Autotype Company, and Messrs. Morgan & Kidd, who kindly read some of the sections and furnished valuable information derived from their practical experience.

The illustrations number nearly one thousand, and in this connection special acknowledgment must be made to the following firms for their great help in kindly having lent electrotypes illustrating modern apparatus, etc., of approved design:—Adams & Co., 26, Charing Cross Rd., W.C.; The Aerograph Co., 30, Memorial Hall Buildings, E.C.; David Allan, Mansfield St., Shoreditch, N.; The Altrincham Rubber Company, Mossburn Buildings, Altrincham; Archer & Sons, 73, Lord St., Liverpool; Andrew H. Baird, 33-39, Lothian St., Edinburgh; C. Baker, 244, High Holborn, W.C.; R. & J. Beck, Ltd., 68, Cornhill, E.C.; F. Beresford, 14, Bridge Road West, Battersea, S.W.; The Busch Camera Co., 35, Charles St., Hatton Garden, E.C.; W. Butcher & Sons, Farringdon Avenue, E.C.; Cadett & Neall, Ltd., Ashstead, Surrey; The City Sale and Exchange, 90/4, Fleet Street, E.C.; Clément & Gilmer, 140, Faubourg Saint-Martin, Paris; J. H. Dallmeyer, Ltd., 25, Newman St., W.; Jonathan Fallowfield, 146, Charing Cross Rd., W.C.; L. Gaumont & Co., 22 and 25, Cecil Court, W.C.; John J. Griffin & Sons, Ltd., 20 to 26, Sardinia St., W.C.; James Henderson, 164, Union Street, Aberdeen; Houghtons, Ltd., 88 and 89, High Holborn, W.C.; Ilford, Ltd., Ilford, E.; The Imperial Dry Plate Co., Ltd., Cricklewood, N.W.; L. Kamm & Co., 27, Powell St., E.C.; Kodak, Ltd., 57-61, Clerkenwell Rd., E.C.; J. Lancaster & Son, Colmore Row, Birmingham; J. Lizars, 101-107, Buchanan St., Glasgow; The London Stereoscopic Co., Ltd., 106-108, Regent Street, W.; G. Mason & Son, Armley, Leeds; Morley & Cooper, 271, Upper St., N.; R. J. Moss & Sons, Snow Hill,

Birmingham; Newman & Guardia, Ltd., 90 and 92, Shaftesbury Avenue, W.; W. Parkinson, Ltd., 62, Dale St., Liverpool; R. W. Paul, 68, High Holborn, W.C.; Penrose Co., 109, Farringdon Rd., E.C.; Perken, Son & Co., Ltd., 99, Hatton Garden, E.C.; T. Quincey P.D. Co., Kentish Town, N.W.; The Quta Photo Machine Co., 34, Norfolk Strand, W.C.; Ross, Ltd., 111, New Bond St., W.; The Rotary Photographic Co., 14, New Union St., Moorfields, E.C.; Sandell Films and Plates, Ltd., Norwood Junction, S.E.; Sanders & Crowhurst, 71, Shaftesbury Avenue, W.; James Sauderson, Union St., Aberdeen; Sanger, Shepherd & Co., 5, 6, 7, Gray's Inn Passage, W.C.; N. L. Scott & Co., 18, Ironmonger Lane, E.C.; C. F. Sears, 4 and 5, Holborn Circus, E.C.; O. Sichel & Co., 52, Bunhill Row, E.C.; A. E. Staley & Co., 19, Tavies Inn, E.C.; J. H. Steward, 406, Strand, W.C.; James Swift & Son, 81, Tottenham Court Rd., W.; Taylor, Taylor & Hobson, Ltd., Stoughton Street Works, Leicester; The Tella Camera Co., 110, Shaftesbury Avenue, W.; The Thornton-Pickard Manufacturing Co., Ltd., Altrincham; Charles Tyler & England Bros., Ltd., 79, Copenhagen St., N.; William Tylar, 41, High St., Aston, Birmingham; Voigtländer & Sohn, 12, Charterhouse St., E.C.; The Watkins Meter Co., Imperial Mills, Hereford; W. Watson & Sons, 313, High Holborn, W.C.; Otis C. White, Worcester, Mass., U.S.A.; The Wizard Camera Co., 32-34, Featherstone St., E.C.; E. G. Wood, 2, Queen St., E.C.; James Woolley, Son & Co., Ltd., Victoria Bridge, Manchester; Carl Zeiss, 29, Margaret St., W.

In conclusion I may claim that this book treats on up-to-date Photography. The intention has been to give explanations that are clear and exact; the Practice is that followed by the most skilled operators; the Theory is dealt with so far as it bears upon the working principles of the art; and there is an abundance of information on the Application of Photography to its many purposes. The Glossary of Terms will suffice to make clear the technical terms that are used, and the very full Index affords an easy means of reference to the varied contents of the book.

P. N. HASLUCK.

CONTENTS.

	PAGE
GLOSSARY OF TERMS	ix
INTRODUCTORY AND ELEMENTARY (22 <i>Illustrations</i>)	1
CAMERAS AND ACCESSORIES (105 <i>Illustrations</i>)	24
PLATES AND FILMS (33 <i>Illustrations</i>)	60
EXPOSURE OF THE PHOTOGRAPHIC PLATE (23 <i>Illustrations</i>)	85
DEVELOPMENT OF PLATES AND FILMS (34 <i>Illustrations</i>)	107
INTENSIFICATION OF NEGATIVES	131
REDUCTION OF NEGATIVES (6 <i>Illustrations</i>)	138
PREPARING THE NEGATIVE FOR PRINTING (30 <i>Illustrations</i>)	145
PRINTING-OUT PROCESSES AND PAPERS (33 <i>Illustrations</i>)	163
DEVELOPMENT PROCESSES OF PRINTING (53 <i>Illustrations</i>)	186
TONING WITH GOLD AND PLATINUM (14 <i>Illustrations</i>)	239
DARK ROOM AND ITS FITTINGS (37 <i>Illustrations</i>)	259
MOUNTING AND FRAMING PHOTOGRAPHS (29 <i>Illustrations</i>)	273
PINHOLE PHOTOGRAPHY	294
ENLARGING, COPYING, AND MAKING LANTERN SLIDES (37 <i>Illustrations</i>)	300
WORKING-UP PRINTS AND ENLARGEMENTS IN MONOCHROME (11 <i>Illustrations</i>)	325
METHODS OF COLOURING PHOTOGRAPHS (15 <i>Illustrations</i>)	337
LENSES : THEIR CONSTRUCTION AND USE (70 <i>Illustrations</i>)	353
CHEMICAL ACTION OF LIGHT (5 <i>Illustrations</i>)	388
CHEMISTRY OF DEVELOPMENT AND TONING (2 <i>Illustrations</i>)	396
THEORY OF THE LATENT IMAGE (1 <i>Illustration</i>)	406
DETERMINATION OF PLATE SPEEDS (5 <i>Illustrations</i>)	412
PHOTOGRAPHY IN COLOURS (22 <i>Illustrations</i>)	420
ORTHOCHROMATIC PHOTOGRAPHY (10 <i>Illustrations</i>)	439
CHEMISTRY OF CARBON COMPOUNDS USED IN PHOTOGRAPHY	454
PORTRAITURE (28 <i>Illustrations</i>)	469
LANDSCAPE PHOTOGRAPHY (46 <i>Illustrations</i>)	489
PHOTOMICROGRAPHY (73 <i>Illustrations</i>)	512
ARCHITECTURAL AND INTERIOR PHOTOGRAPHY (14 <i>Illustrations</i>)	551
SPECTROPHOTOGRAPHY (30 <i>Illustrations</i>)	562
MONUMENTAL WORK (7 <i>Illustrations</i>)	586
ASTRONOMICAL PHOTOGRAPHY (17 <i>Illustrations</i>)	594
STEREOSCOPIC PHOTOGRAPHY (45 <i>Illustrations</i>)	612
NATURAL HISTORY PHOTOGRAPHY (5 <i>Illustrations</i>)	638
TELEPHOTOGRAPHY (7 <i>Illustrations</i>)	646
PHOTO-CERAMICS (4 <i>Illustrations</i>)	653
ANIMATED PHOTOGRAPHY (7 <i>Illustrations</i>)	664
TREATMENT OF RESIDUES (1 <i>Illustration</i>)	674
PHOTO-MECHANICAL PROCESSES (35 <i>Illustrations</i>)	677
RADIOGRAPHY (7 <i>Illustrations</i>)	704
MISCELLANEOUS ITEMS (10 <i>Illustrations</i>)	712
TABLES	718
PERMITS TO PHOTOGRAPH	720
INDEX	721

LIST OF PLATES.

	<i>Frontispiece</i>
1.—REPRODUCTION OF RED CHALK CARBON PRINT	<i>To face page</i> 16
2.—REPRODUCTION OF PLATINUM PRINT AFTER DEVELOPMENT	33
3.—POSITIVE AND NEGATIVE PHOTOGRAPHS	48
4.—SPECIMEN OF PHOTOGRAPHING INTERIORS
5.—EFFECT OF BROMIDE IN OVER-EXPOSURE; EFFECT OF INTENSIFICATION IN UNDER-EXPOSURE	65
6.—UNTOUCHED PHOTOGRAPH	80
7.—RETOUCHED PHOTOGRAPH	97
8.—EXAMPLES OF FACTORIAL DEVELOPMENT	112
9.—SPECIMEN OF PLATINUM PRINT BEFORE DEVELOPMENT	113
10.—SPECIMEN OF PLATINOTYPE AFTER DEVELOPMENT	128
11.—EXAMPLES OF PINHOLE PHOTOGRAPHY	145
12.—SPECIMEN FROM UNDER-EXPOSED NEGATIVE; SPECIMEN FROM OVER-EXPOSED NEGATIVE	160
13.—PRINT FROM CORRECTLY-EXPOSED NEGATIVE: EXAMPLE OF PHOTOMICROGRAPHY	161
14.—EXAMPLE OF BLOCKING OUT FIGURE AND INSERTING BACKGROUND	176
15.—EXAMPLE OF FLASHLIGHT PHOTOGRAPHY	193
16.—EXAMPLES OF TEST EXPOSURES WITH TALLENT'S DIFFRACTION SPECTROSCOPIC CAMERA	208
17.—EXAMPLES OF BROMIDE PRINTING	225
18.—EXAMPLES OF DODGING	240
19.-20.—EXAMPLES OF STUDIO LIGHTING	257, 272
21.—FRAME MOULDINGS FOR PHOTOGRAPHS	289
22.—INTERIOR OF HENRY VII.'S CHAPEL, WESTMINSTER ABBEY	304
23.—OUTDOOR FIGURE STUDY	321
—STUDIO WORK: TAKING HEAD AND SHOULDERS PORTRAIT	336
—PHOTOMICROGRAPHY	353
—RUINS: WHITBY ABBEY (NORTH AISLE)	368
—PHOTOMICROGRAPHY	385
—STEREOSCOPIC NIGHT PHOTOGRAPHY	400
—PICTURE PRINTED BY COMBINATION OF YELLOW, RED, AND BLUE INKS ONLY	417
—PRINT COMBINING YELLOW AND RED	432
—PRINT FROM RED BLOCK ONLY: PRINT COMBINING YELLOW AND BLUE	449
—PRINT FROM BLUE BLOCK ONLY: PRINT COMBINING RED AND BLUE	464
23a.—PHOTOMICROGRAPHY	481, 496
—COLOUR RENDERING OF ORDINARY AND OF ORTHOCHROMATIC PLATES	513
—SPECTROPHOTOGRAPHY	528
—PANELED ROOM (VICTORIA AND ALBERT MUSEUM)	545
38.—FLOWER STUDY	560
39.—STEREOSCOPIC PICTURES TAKEN ON ONE PLATE BY TURNING THE CAMERA ON ITS AXIS BETWEEN THE TWO EXPOSURES	577
40.—A GOOD COMPOSITION FOR STEREOSCOPY, BUT BADLY LIGHTED	592
41.—EXAMPLES OF NATURAL HISTORY PHOTOGRAPHY	609
42.—EXAMPLES OF INSTANTANEOUS PHOTOGRAPHY	624
43.—SPECIMENS OF FILMS FOR ANIMATED PHOTOGRAPHY	640
44.—EXAMPLES OF INSTANTANEOUS PHOTOGRAPHY	656
45.—RADIOGRAPHY	673
46.—SPECIMENS OF WORK DONE WITH "N. AND G." CAMERAS	688
47.—RADIOGRAPHY	693
48.—REFLECTIONS DONE WITH "N. AND G." CAMERA	700

THE BOOK OF PHOTOGRAPHY

INTRODUCTORY AND ELEMENTARY.

PLAN OF THE PRESENT WORK.

THE aim of this book is to teach the reader the whole art of photography, practical, theoretic, and applied. The novice will be taken by easy stages through all its branches, while those already possessing a knowledge of photography will be given an insight into processes and methods which will enable them to undertake work of any description. No effort has been spared to make the information and instructions given as complete as possible. The theoretical side of the subject will be treated separately from the practical, in order that those who wish to proceed at once to actual work may not be embarrassed by a multitude of uncertain and largely speculative conclusions. At the same time, others who desire to obtain a thoroughly scientific grasp of the subject will find the theoretical aspect of photography duly and fully considered.

THE PRINCIPLE OF PHOTOGRAPHY.

Photography, as its name implies, consists of drawing by the aid of light, and is based upon the fact that various substances undergo such changes in their condition as to exhibit new properties under the action of light. This new property, generally speaking, consists of their changing colour, usually to a darker shade, when exposed to light. Precisely how these

changes are brought about need not be considered at the present moment, as they will be fully discussed later, when dealing with the theoretical principles involved in photographic action. In this section, all that will be given is a brief outline of the methods in everyday use, such as can be adopted readily by beginners.

USES OF PHOTOGRAPHY.

The progress of photography during recent years has been rapid and phenomenal. New fields of usefulness have been discovered, involving fresh and novel applications of the art-science to the increasingly exacting demands of modern life. The great bulk of magazine and book illustrations, the pictorial chronicle of current events, the beautiful photogravures and tri-colour reproductions which have made the pictures of the world's famous artists familiar to us all—these, and numerous other advantages, are the outcome of the perfected camera. The physician and the surgeon have gathered wider knowledge of the complicated human system by means of photomicrography and the Röntgen rays; the astronomer has discovered, by means of the sensitive plate, stellar systems otherwise imperceivable, even with the aid of a telescope. Aided by the optical lantern and cinematograph the crowded assembly at places of popular entertainment may

witness all the incidents and movements of a royal progress, a steeplechase, or yacht race within a few hours of the actual event. These are only a few of the many applications of photography; there is scarcely an art or an industry that is not indebted to it, directly or indirectly.

VALUE OF PHOTOGRAPHIC KNOWLEDGE.

The man or woman who wishes to be perfectly equipped in these competitive times, when everyone is eager to take advantage of all the assistance that science and technical training can confer, should have at least a slight knowledge of photography. It is sure to be of use at

was invented by Giambattista della Porta, generally spoken of as Baptista Porta, of Padua, in 1569; although there is evidence of an even earlier knowledge of its principle and properties. This simple instrument depends in principle on the fact that if a tiny hole is made in the shutter of a room, from which light is otherwise excluded, a small reversed image of the view outside will, under favourable conditions, be thrown on the opposite wall. This experiment appears to have been known to philosophers from time immemorial, but it was not till later that the improvement effected by using a convex lens in place of the

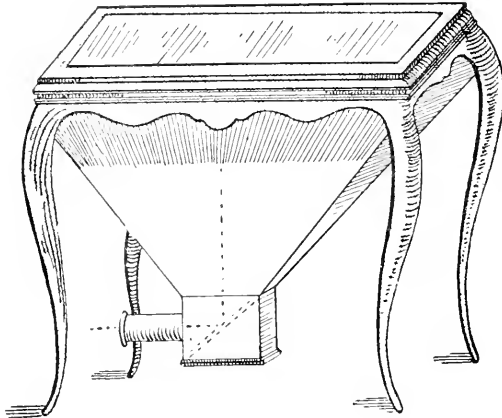

Fig. 1.—GUYOT'S CAMERA OBSCURA.

one time or another, and may be perhaps of the very highest value. Even when the study of photography brings no monetary return, a great amount of pleasure and recreation is derived from the pursuit of what seldom fails to become a most fascinating hobby.

EARLY HISTORY OF PHOTOGRAPHY.

Photography may be described as the offspring of optics and chemistry. If the camera obscura had not been ready to hand, to cast a miniature picture on the sensitive plate or film, the discovery of the actinic power of light on certain substances would have been valueless, except as a scientific curiosity. The camera obscura (Latin = dark chamber)

hole was discovered. The idea of enclosing the lens in a small box, with a screen of tracing paper or ground glass, first occurred to Porta, as already stated, in 1569. The box form of camera obscura appears to have been used as an entertaining toy, or as a ready means of tracing landscapes and views, for nearly three centuries before the discovery of photography. The apparatus is mentioned by the Abbé Nollet, in his "Leçons de Physique," published at Paris in 1755. A quaint form of camera obscura, with folding legs, designed by A. M. Guyot, for outdoor work in tracing landscapes, is shown by Fig. 1. This illustration is copied from a work published in London in 1774 entitled "Hooper's Rational Recreations." As will

be seen, it resembles an ordinary table; the camera is situated between the legs, the top being formed by a sheet of plain glass, on which a piece of tracing paper is laid. The image formed by a convex lens is thrown upward on the screen by means of an inclined mirror. The low point of view adopted in this instrument must have led to peculiar results, but possibly it was intended for use on the top of high buildings or at other places where an unobstructed view could be obtained.

FIRST RECORDED EXPERIMENTS IN ACTINISM.

The earliest known discovery of the actinic action of light appears to have been made by the alchemist Fabricius in 1556. He observed that the sun's rays had a blackening effect on horn silver, a crude form of silver chloride found in the mines of Freiberg. In its native state horn silver is colourless, but rapidly assumes a violet tint on exposure to a strong light. This property of darkening on being exposed to the light is still more noticeable in nitrate of silver, so frequently used in medicine under the name of lunar caustic. These experiments, although attracting from time to time a good deal of attention, were not followed to any practical conclusion till a much later period. In 1777, Carl Wilhelm Scheele, of Köping, found that the violet rays of the spectrum acted more powerfully upon silver chloride than any of the other rays. This conclusion was confirmed a few years later by Jean Senebier, of Geneva, who had experimented further in this direction. In 1786 Scheele discovered that light exerted a chemically decomposing effect on various solutions, causing them to resolve into their constituents, or to recombine in different forms. Other valuable additions to scientific knowledge of the action of light were made by B. Fischer, J. W. Ritter, of Jena, and many other investigators.

THE FIRST PHOTOGRAPH.

The earliest actual application of the darkening action of light on silver salts is said to have been made by Professor

Charles, at the Louvre, in 1780. He cast the silhouette of one of his pupils, by means of a powerful ray of light, upon a sheet of paper treated with silver chloride. The paper immediately began to discolour and blacken at those parts which were exposed, while the parts in shadow remained white. As a consequence, the



Fig. 2.—EXAMPLE OF WEDGWOOD AND DAVY'S PROCESS.

figure of the scholar was produced in white on a black ground. The picture, however, was not permanent, but began to darken all over directly the shadow was removed. Considerable scepticism has been displayed as to this traditional success of M. Charles, as apparently he left no record of the fact behind him.

WEDGWOOD AND DAVY'S EXPERIMENTS.

In 1802 an account of certain researches made by Thomas Wedgwood, a son of the famous potter, and Sir Humphry Davy was published in the journal of the Royal Institution, in which were made known to the public "a method of copying paintings

upon glass, and of making profiles by the agency of light upon nitrate of silver." This process was really what is now referred to in photography as printing, and consisted simply of obtaining prints or silhouettes of suitable objects by exposing them to light in contact with paper prepared with a solution of nitrate of silver (see Fig. 2). Attempts had been made by both Wedgwood and Davy, without success, to secure a reproduction of the image formed in a camera obscura; although the latter was enabled to copy the images of small objects, produced by means of the solar microscope, when the paper was placed a short distance from the lens. All endeavours to render the prints permanent were, however, unsuccessful.

DISCOVERIES OF NIEPCE.

The lion's share of the honour due to the discoverer of photography must be given to Joseph Nicéphore Niepce, who was born at Châlons-sur-Saône in 1765. Taking a great interest in lithography, then recently invented, he spent much time in trying to improve the process. The method of drawing on the stone struck him as tedious, and being well acquainted with the actinic properties of chloride of silver, he tried to reproduce the drawing, purposely made on transparent paper, by exposure to light in contact with a suitable surface prepared with a silver salt. The dark portions of the original, obstructing the light, left the prepared portions white; while the rest became dark. A negative was thus obtained from which, by a second printing, an exact reproduction of the original might be secured. Niepce, however, encountered the same difficulty that thwarted Wedgwood and Davy—he was unable to fix, or render permanent, the images he obtained. He was led, therefore, to experiment in some other substance. In the course of his investigations he found that asphalt, or bitumen of Judæa, was readily dissolved by ethereal oils, such as turpentine, petroleum, oil of lavender, etc. Niepce was already aware that bitumen of Judæa possessed the property of be-

coming insoluble by the action of light, and, putting these two facts together, he was able to devise an ingenious and successful method of reproducing a permanent photographic image.

NIEPCE'S APPLICATION OF THE BITUMEN PROCESS.

A metal plate was coated with a solution of bitumen, and allowed to dry. It was then exposed for several hours to the image formed inside a camera obscura, the result being that the parts affected by light were rendered insoluble, while the rest remained unaltered. There is no change perceptible to the eye, but on the application of oil of lavender, those parts unaffected by light are dissolved away, while the exposed portions remain. Niepce had, in fact, obtained a photograph, or, as he called it, a heliograph—a picture traced upon the metal plate in varying gradations of asphalt. He was not long in applying his discovery to the purpose for which it was primarily intended, and was soon able, by the use of acid, to etch out the image obtained in this manner on copper and other metals. It is, indeed, an improvement on the method of heliography, or sun drawing, invented by Niepce's nephew, Niepce de Saint-Victor, which is now principally in use for the printing of bank-notes and cheques. Heliography was the term applied to his process by Niepce himself; nowadays the word is used with quite a different meaning. The picture formed by the bitumen on the metal plates was a negative one, and although suitable for etching, was not satisfactory for viewing. Niepce overcame this by blackening the metal plate with iodine. In 1829 Niepce entered into partnership, which lasted till his death in 1833, with Louis Jacques Mande Daguerre, who made many improvements in the heliographic process. Daguerre was born at Cormeilles, near Paris, in 1789, and died in 1851.

DAGUERRE'S DISCOVERIES.

It has been pointed out that Niepce found it necessary to blacken the metal plates on which his pictures were obtained

by the action of iodine. It should be explained that for ordinary work, not intended for engraving, silver plates—on which a brown image was formed by the bitumen, the shadows being represented by the polished metal—had been found more suitable. Iodine had the effect of darkening the bare spaces of silver, the rest being protected in due gradation by the coating of bitumen. After the shadows had been blackened, the brown image of bitumen was removed, leaving a positive picture on silver, in black and white. It was not long before Daguerre, struck probably by this blackening action of iodine on silver, which he observed would not take place except by exposure to light, turned his attention to the possibility of obtaining photographs on silver plates sensitised by exposing to the vapour of iodine. This proved to be quite feasible. Such plates assumed a brown colour in the camera on those portions which received the image. A very long exposure was, however, found to be necessary. By a fortunate accident Daguerre discovered that a silver plate sensitised with iodine could be developed, although previously the image was invisible, by exposure to mercury vapour. Another great advance was rendered possible by the discovery, soon after this, that the photographic image could be fixed by a strong solution of common salt. Just as success was achieved Niepce died.

FURTHER ADVANCES.

Shortly after the Daguerreotype process had been given to the world (in 1839), Sir John Herschell suggested that hyposulphite of soda would form a better and more efficient agent for fixing purposes; and from this time the progress of photography was a triumphal march. Daguerre himself, and other photographers, had found out how the silver iodide plates might be made much more rapid by the addition of bromine, or the use of chlorine vapour. The length of exposure necessary was soon reduced to such an extent that at last photographic portraiture was rendered possible. Up till then, the work of the camera had been limited to views and

still-life subjects. Even when the Daguerreotype process had reached its most perfect stage, exposures varying from three minutes to half an hour were required. Five minutes was the average length of time in which a portrait could be taken; and that, too, in strong sunlight out in the open.

WORK OF HENRY FOX-TALBOT.

Almost simultaneously with the work of Niepce and Daguerre, an English investigator was pursuing the same objects, and arriving at equally valuable results, although on an entirely different principle. Daguerre's method was, as has been explained, a direct positive process; that is to say, a finished picture, correct as regards light and shade, was produced at one operation. This, however convenient from one point of view, had manifestly the disadvantage that if a number of copies were required a separate exposure had to be made for each; it was, besides, very difficult to obtain them closely alike. The Calotype process, patented by Henry Fox-Talbot in 1841, was the first step towards a new order of things. Paper sensitised with silver iodide was brushed over with a mixture of silver nitrate and gallic acid, and exposed in the camera while still wet, this having the effect of greatly reducing the time of exposure. The image was developed with gallo-nitrate of silver, the picture being gently heated at the same time.

FIRST NEGATIVE PROCESS.

The Calotype process produced, for the first time, negatives instead of positives—pictures, that is, in which everything was reversed as regards light and shade. The advantage of this is soon explained. When the paper had been rendered translucent with paraffin wax, or other means, it could be placed in front of a similar sensitive film and the two exposed in contact to the action of light. The effect would be a second reversal of the light and shade, and the original picture would be correctly reproduced in the resulting positive. It is also evident that the photographer was no longer limited to one

copy of each subject, but could produce an almost unlimited number from one negative.

INTRODUCTION OF GLASS PLATES.

Paper, as then prepared, being found a very inconvenient support for the sensitised material, efforts had been made by different persons to obtain a more transparent medium. In 1848, Niepce de Saint-Victor, a nephew of the pioneer of photography, made known his albumen negative process on glass. The glass plate was coated with a thin layer of albumen, which was sensitised by saturation with silver iodide. When dry, the plate could be used to obtain a negative in the camera, which, after development and fixation, was found extremely easy to print from. This process was greatly improved by Blanquart-Evrard, Le Gray, and others.

INTRODUCTION OF COLLODION.

It is to Frederick Scott-Archer that credit must be given for the next step forward, although it is true that Le Gray and Bingham, if not others, at least made suggestions in the same direction previously. In 1850, Scott-Archer made known his wet collodion process, which was so vast an improvement on anything hitherto achieved that it came almost at once to the front. The details of the process will be fully dealt with in a later section, but a brief outline may here be given. A glass plate is coated with a thin film of collodion, a viscid compound consisting of gun-cotton dissolved in alcohol with the addition of ether and some soluble iodide or bromide salt. The coating is allowed to set, and the plate immersed in a solution of silver nitrate, where it is permitted to remain for about a minute. Silver iodide is formed in the pores of the collodion, rendering the plate sensitive and ready for exposure. It is exposed while wet, development being effected by pyrogallic acid, and fixing by hyposulphite of soda; cyanide of potassium was afterwards adopted for fixing purposes, on account of its quicker action. This process for more than thirty years was the sheet-anchor of professional photographers, but the necessity of using the plate in

a wet state was often a great inconvenience, and many attempts were made to produce a ready-sensitised collodion plate which could be used dry.

THE SENSITISERS.

Dr. Hill Norris, of Birmingham, was the first to solve the problem satisfactorily, by the collodion dry-plates which he introduced in 1856. Other discoveries in the same direction were afterwards made by Major Russell, Sir W. (then Captain) Abney, and others. But no real advance could be made until the necessity of using the nitrate bath was altogether obviated, by introducing the sensitive salt in the collodion vehicle itself. This desideratum was supplied in 1864, by Mr. B. J. Sayce and Mr. W. B. Bolton, of Liverpool, who succeeded in making a satisfactory emulsion of collodion in combination with the necessary sensitive reagents, with which the plates could be at once coated and dried. This improvement was soon followed by others, until collodion emulsion of great sensitiveness, and possessing excellent keeping properties, was produced.

ADVENT OF THE GELATINE PLATE.

The next improvement which brought photography to its present pitch of perfection was the substitution of gelatine for collodion in the making of emulsions. Many clever workers had been devoting time and attention to the problem of securing a less dangerous and more generally suitable vehicle than collodion to hold the sensitive salts in suspension; and in 1871 Dr. R. L. Maddox, of Southampton, was able to publish the particulars of an emulsion composed of gelatine and bromide of silver. Kermetter, Burgess, Kennett, Stas, and others followed with valuable suggestions and practical improvements. In 1878, Mr. Charles Bennett, of London, first suggested keeping the emulsion at a temperature of 90° F. for about a week for the purpose of increasing sensitiveness. Colonel Stuart Wortley next introduced the plan of keeping the emulsion at a still higher temperature, say 150° F., for a few hours only, which resulted in a

similar increase in rapidity. Mr. G. Mansfield suggested boiling the gelatine, but this was not practicable until Mr. W. B. Bolton

with certain modifications, are still employed. A wonderful increase in rapidity was thereby rendered possible; instantane-



Fig. 3.—A PHOTOGRAPHIC NEGATIVE.

hit upon the ingenious idea of emulsifying with a portion of the gelatine only. Dr. Van Monckhoven, of Ghent, shortly after this introduced the method of ripening by the addition of ammonia. These methods,

ous photography had become, at last, an accomplished fact. It is true that rapid work had been done before with wet collodion; but this was the exception rather than the rule.

PERFECTION OF THE CAMERA.

Contemporary with the advances made in the method of production, important

by itinerant photographers, with the elaborate and beautifully finished cameras now obtainable, to appreciate the full extent

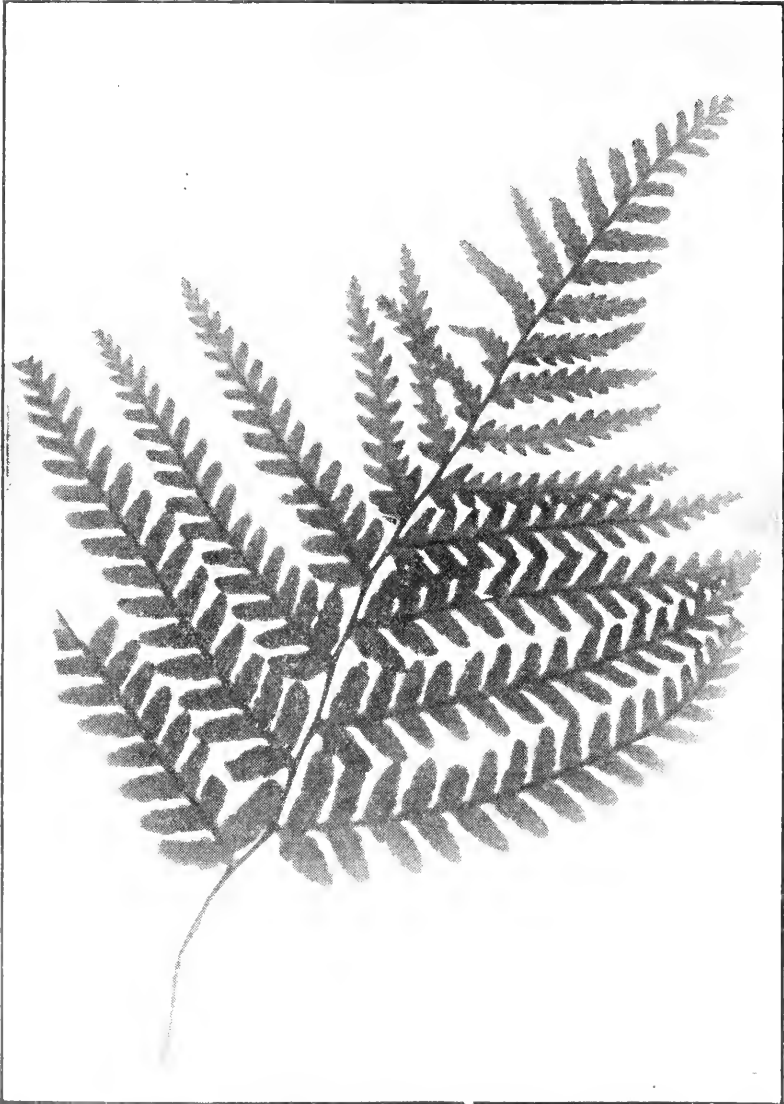

Fig. 4.—A PHOTOGRAPHIC POSITIVE.

modifications have been effected in the construction of the camera and other apparatus used in photography. It is only necessary to compare an early wet-plate camera, such as are still sometimes used

of the change. Lenses also have been greatly improved, and now give clearer and more correct representations. They are, in addition, more rapid, thus reducing the time necessary for exposure. A large

number of printing processes have been introduced, with which a wide range of results are possible. It has also become practicable to apply photography to letterpress printing, engraving, lithography, and other arts and crafts, as well as to various departments of scientific work. Sufficient has, however, been said to afford a general idea of the evolution of the modern photograph. It is now proposed to explain briefly some of the fundamental principles underlying the practice of photography.

NEGATIVES AND POSITIVES.

The first attempts in photography were in the making of silhouette or shadow pictures, simply giving the outline of objects. Such impressions were necessarily of a "negative" kind; that is, light objects were represented as black, and black objects were shown as white. Suppose, for example, a dark green fern leaf were placed upon a sheet of photographic paper and exposed to daylight; the leaf would be represented on the paper in exactly opposite effect to that seen when held up to the light. Such an impression would be a negative, as shown by Fig. 3. Now if another piece of paper were exposed beneath the first or negative impression, the light would act most through those parts which before had been unchanged, with the result that an exact opposite of the negative would be shown; this is called a "positive" (see Fig. 4). Such positives are generally spoken of as "prints," and the process of taking positive impressions from negatives as "printing." Negatives or prints may be on either paper or glass, but generally speaking negatives are on glass and prints on paper. Printing from a negative is one of the simplest of photographic operations, and the novice cannot do better than start by making a positive print.

MAKING A PHOTOGRAPHIC PRINT FROM A LEAF.

Procure a packet of ferro-prussiate paper, which can be purchased for one shilling, containing 25 pieces, at any photographic chemist's. Next borrow a negative from a friend. If this is not possible,

then some leaves of a tree may be utilised. Now take three pieces of glass, one about $6\frac{1}{2}$ in. by $4\frac{3}{4}$ in. and two others $4\frac{1}{2}$ in. by $3\frac{1}{4}$ in. Lay down the large glass, and on it, in the centre, place the leaf. Over this lay the sheet of photographic paper, sensitive side downwards, against the leaf. Over this, again, lay the two small glasses, and clip all together with two paper clips, as shown in Fig. 5. Next turn the arrangement over, so that the large glass is

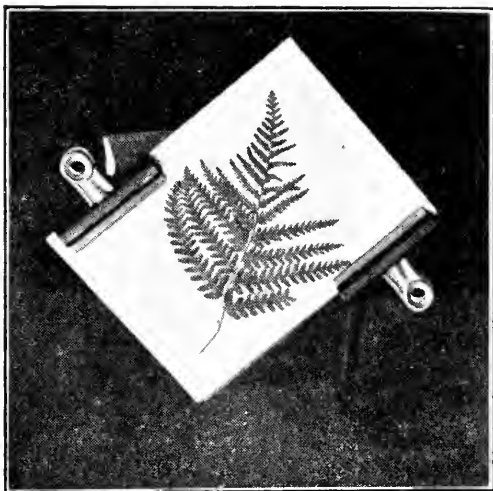

Fig. 5.—SIMPLEST FORM OF PRINTING FRAME.

uppermost exposed to the sky, as shown in the illustration, and watch it till the paper turns a deep blue, which it will do fairly rapidly. The operation of filling in the paper, etc., should be done indoors, and in not too strong a light, for obviously if it is desired to secure a contrast between the parts beneath the leaf and the parts outside it, then the less light admitted to the paper in the parts beneath the leaf the better.

MAKING A PHOTOGRAPHIC PRINT FROM A NEGATIVE.

Supposing, however, that the student has been fortunate enough to secure the loan of a negative. On examination it will be seen to have a shiny side and a dull side. The dull side bears the image;

therefore the closer the paper can be fixed to it the better. Place the sensitive side of the paper against the negative film, and over this lay two thicknesses of clean blotting-paper; then connect up as before. When the paper appears to be turning a decided blue, turn it over and release one of the glasses; the paper may then be turned back and examined without any fear of altering its position on the negative. This should be done from time to time until the print shows all the detail required, when it may be taken out and washed in clean water in any convenient vessel—say in a pie-dish, or even a soup plate. In photography, “washing” usually means soaking, the object being to dissolve away something from the paper.

SIMPLEST FORM OF CAMERA.

A photographic image is formed on a plate, rendered sensitive to the action of light, by throwing upon it a reflection of the object or scene to be photographed. Those parts of the plate receiving the light portions of the image are affected by the different degrees of illumination they receive, the darker or shadow portions of the image making little or no impression. This being so, no light except that proceeding from the image itself must be allowed to fall upon the plate during exposure, or it will be affected all over, instead of only in parts, and a satisfactory picture will, therefore, not be obtained. The

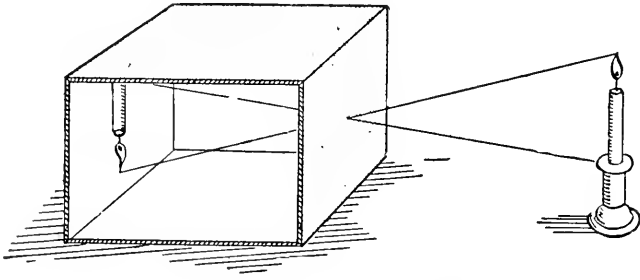

Fig. 6.—SIMPLEST FORM OF CAMERA.

This washing consists of laying the print in the water. After a few moments pour this water away, and fill and soak again. After about twenty minutes' washing the print is finished, and may be taken out and dried. This experiment illustrates the simplest process of making a print-out impression, and is the one used in engineers' offices for copying plans, etc. For general work such a process would not be satisfactory, as the image or picture is of a disagreeable colour, and appears sunken on the paper, the finer details being lost; but as a preliminary experiment it has the advantages of simplicity and cheapness. Let the student now take a step further and make a print-out impression on albumen paper. For the proper working of this process some more apparatus will be necessary.

primary object of the camera is to provide a light-tight box, or dark chamber, in which the sensitive plate can be protected from all light except that which is reflected from the object or view being taken. If a tiny hole were pierced through one of the sides of a small light-tight box with a fine needle or tiny drill, it would be noticed that a candle-flame or gas-jet placed a short distance in front of the aperture would form its image on the side of the box opposite to the hole. By opening the lid, and covering the head and the top of the box with a black cloth to exclude extraneous light, the representation of the candle-flame, or gas-flame, would be plainly seen upside down. This may be better understood by reference to Fig. 6. The rays of light, it will be seen, proceed in straight lines from all

parts of the object, and, those which travel in the direction of the hole as shown, meet and cross each other, so that the continuation of their course, on the other side of the aperture, results in the formation of a reversed image, when the rays reach a surface capable of reflecting them. Here are all the elements which go to the making

admit enough light; the image consequently is very faint, and requires considerable time to impress itself on the sensitive plate. This difficulty is removed by the employment of a lens, a piece of ground optical glass, or combination of glasses, having the surfaces curved to such a shape that rays of light passing

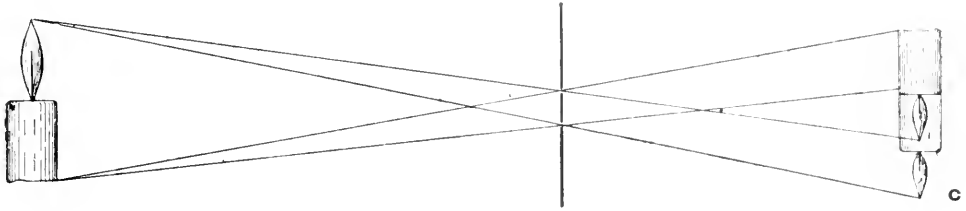

Fig. 7.—RAYS OF LIGHT PASSING THROUGH TWO PINHOLES.

of the simplest form of camera: a light-tight box in which the plate may be exposed, and an aperture through which may pass the rays of light which form an image or picture on the sensitive surface. At the present time "pinhole photography," as it is called, is practised by some amateurs, more especially by those who desire to

through them are refracted, or bent aside, and caused to come together again inside the camera, forming an image or picture similar to that made by the tiny hole, but having the great advantage of being sharper and clearer, and, owing to the larger size of the lens opening, much better illuminated. To make this clearer,

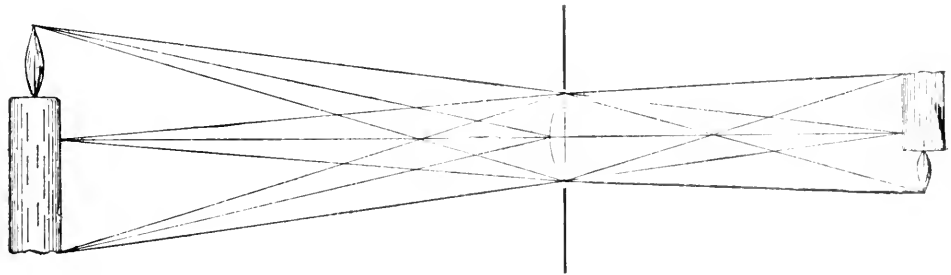

Fig. 8.—RAYS OF LIGHT PASSING THROUGH LENS.

secure a "fuzzy" effect. It is, however, quite possible to get really good pictures without a lens, some results being possible with a pinhole which are obtainable in no other way, but the great drawback to the process is the necessarily prolonged exposure.

THE LENS.

The tiny hole or perforation through which a photographic image is obtained has one great disadvantage: it does not

let the following experiment be made. Place a candle flame and a card pierced with a pinhole in the position shown in Fig. 7, and an inverted image of the candle will appear on the card c. By making another hole $\frac{1}{2}$ in. away from the first, a second image of the candle will be formed by those rays which travel in the direction of this hole as shown and overlapping the first image. Now if the portion between these is gradually per-

forated, further images will be produced, each overlapping until the image becomes too blurred to be distinguished. Cover this opening with an ordinary spectacle lens, a reading glass, or any other kind of lens at hand, and distinction will be restored by means of refraction or beading of the rays together, as shown in fig. 8, with the result that an even clearer and much brighter image is produced than that obtained with the pin-hole, but with this difference—that when the card *c* is moved the image at once becomes indistinct or out of focus.

THE FOCUSsing SCREEN.

The simple form of dark-box which constitutes the foundation of the camera possesses another disadvantage: there is no convenient means of ascertaining what kind of a picture is being thrown inside, except by the clumsy expedient of raising the lid. The plate would then have to be placed inside, this operation of necessity taking place in a room from which white light had been excluded, and the box finally taken back and carefully placed in its former position to give the exposure. All this trouble is avoided by the use of what is known as the focussing screen. This consists of a sheet of ground glass held in a light wooden frame, which is arranged to fit the back of the camera in such a manner that the surface of the ground glass comes in exactly the same place as will afterwards be occupied by the plate. Operations are thus much simplified. The picture cast on the screen by the lens can be readily examined, and arranged in the most favourable position.

FOCUSsing.

The image thrown by the lens, therefore, is not equally distinct or "sharp" at all distances; that is to say, if an object 4 ft. distant from the camera is perfectly clear and sharp on the ground glass screen, another that is 50 ft. distant will be vague and indistinct. Or, to put it in another way, if the picture on the ground glass screen is quite sharp when the lens is 6 in. distant, it will be unrecognisable if the lens is moved 2 in. nearer or farther

from the back of the camera. This would not be the case with a tiny hole, which would give a picture of practically the same definition however the distance between the aperture and the plate might be altered. Some means of adjustment is, therefore, necessary for altering or regulating the distance between the lens and the ground-glass screen. This is provided by a rackwork movement which slides the front of the camera, holding the lens, nearer to or farther away from the back. Some cameras are focussed by moving the back instead of the front. The earliest focussing arrangement consisted of two boxes, one of which moved to and fro inside the other. The operation of adjusting the distance between the lens and the screen is called focussing, because the rays of light forming the different portions of the image are brought to a point or focus.

THE SWING-BACK.

A very important feature of modern cameras is the swing-back. It often happens that a photographer, when taking a high building, is unable to get far enough back to include the whole of it on the focussing screen without tilting up the camera; but this causes vertical lines to converge towards the top. The swing-back is therefore brought into requisition, and by its action the plate swings to a vertical position.

THE DARK SLIDE.

The adoption of the focussing screen involves the addition of yet another fitting. It is necessary, of course, that the sensitive plate must be placed in the exact position previously occupied by the screen. It is also evident that it would be difficult to do this without either moving the camera to a dark-room or spoiling the plate by premature exposure to light. To meet this difficulty the dark-slide is used. In its simplest form, this is a shallow light-tight box, large enough to hold the plate, and arranged to slide in the groove or recess filled by the focussing screen. The dark-slide is furnished with a withdrawable shutter, which is pulled nearly or quite out when it is desired to expose the plate.

METHOD OF EXPOSING THE PLATE.

All that is now required for the successful exposure of the plate is a means of shutting off the light from the lens until the dark-slide is pulled open, and then admitting it for just the necessary period. The simplest way of doing this is by the use of a small leather removable cover, known as the cap, which fits over the front of the lens. The camera having been placed in position, the cap is removed

slide removed from the camera. Other methods of exposing the plate are by means of roller blind or drop shutters working in front of or behind the lens, and by means of a diaphragm shutter working between the glasses of the lens.

FIRST LESSON IN EXPOSURE.

It is assumed that the learner possesses some kind of camera. It is also taken for granted that a room or cupboard, from which white light can be completely

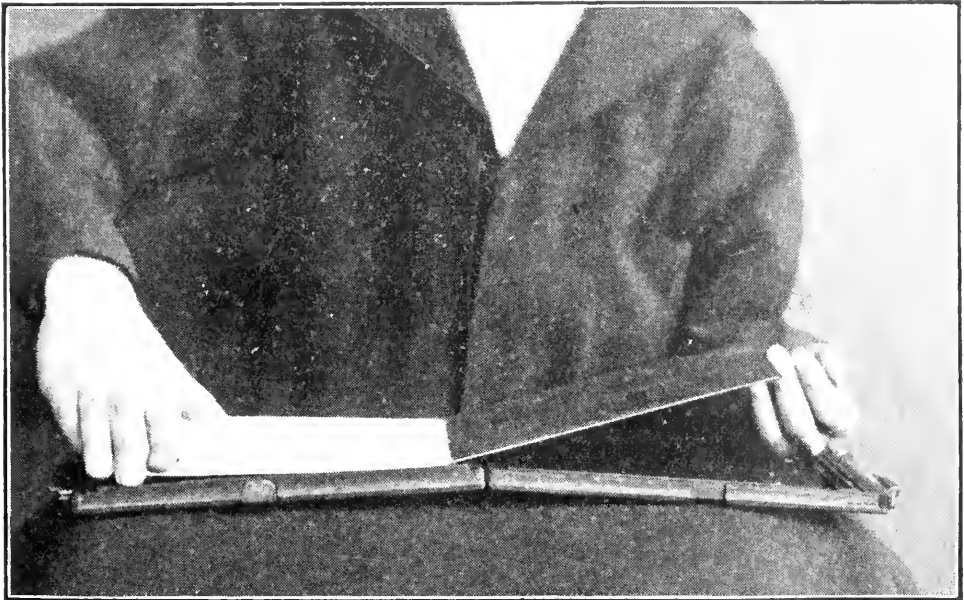

Fig. 9.—PLACING THE SENSITIVE PLATE IN THE DARK SLIDE.

from the lens, and the image focussed sharply on the ground-glass screen. When all is considered to be suitably arranged, the cap is placed over the lens, and the focussing screen removed. The dark-slide, containing the plate, is then inserted in the groove which held the focussing screen, the sensitive plate occupying exactly the same position as the glass of the screen. The shutter of the slide is now drawn out, and the plate is ready for exposure. This is accomplished by gently removing the cap from the lens, taking care not to shake the camera, and replacing it as soon as the light has had time to act. The shutter of the slide is then pushed back, and the

excluded, and containing a ruby window or lamp for working by, is accessible. The initial step is to insert the plate in the dark-slide. On entering the dark-room with the slide and a box of dry-plates, the door is closed and a careful examination made with a view to shutting out any white light that may penetrate through a crack or hole. The ruby lamp, if there is no ruby window, should be adjusted to give just sufficient light to enable the worker to see without straining the eyes.

PLATES.

Any make of plate of the rapidity known as Ordinary, are the best to start with. It

is supposed that the slide is one of the book-form kind, as supplied with most stand cameras. It is unfastened by moving aside the clips, and laid flat on the bench or table, and the partition of metal or black cardboard found inside, if removable, is taken out. The box of plates is next opened, and a plate lifted out by the edges, care being taken not to touch the sensitive surface. The plate

The slide may now be taken out of the dark-room, and the camera set up.

CHOICE OF SUBJECT.

A typical open landscape or view should be chosen for the first experiment ; a large garden with nothing in the foreground to stop the light will be just the thing. In the event of a garden not being available, a scene similar to that shown by Fig. 10



Fig. 10.—EXAMPLE OF SIMPLE SUBJECT FOR BEGINNERS.

is laid, film downward, in the rebate of the slide (see Fig. 9). The film side is easily distinguished by its dull and milky appearance, the glass side being smooth and shiny. The dividing partition is placed on the top of the plate, and a second plate is taken from the box, and placed in the slide on top of the partition, with the film side up. The slide is then closed and fastened. The shutters may as well be pulled out and pushed back again, to see that all is in working order. The catches, which stop them from being accidentally withdrawn, should then be fixed.

should be selected, where, it will be noticed, there is nothing sufficiently near to the camera to cast heavy shadows. Better than either is an advertisement hoarding, where there is plenty of clear print to focus all on one plane. The camera having been erected in position, the cap is removed and the scene focussed sharply on the ground glass screen by gently turning the screw. No great trouble need be taken in arranging the picture at this stage ; all that is necessary is that the scene roughly included on the screen is clear and distinct.

TAKING THE PICTURE.

The focussing screen is then removed, and, the cap having been placed over the lens, the dark-slide inserted. The shutter is pulled out on the side nearest to the lens; this being done under the shade of the black cloth or velvet known as the focussing cloth. The view being taken should be brightly lighted, but should not be in full sunlight. It is important, also, to keep the camera and lens out of the direct rays of the sun. Exposure is made by gently but quickly removing the cap and replacing it as rapidly as possible. It will be noticed that the lens is provided with a device for diminishing the size of the opening. This may be an Iris diaphragm, consisting of a metal ring on the mount, by revolving which the circular aperture inside the lens is caused to grow larger or smaller; or the lens may be furnished with several loose metal slides perforated with holes of different sizes, or with a revolving disc containing similar perforations round the rim. The use of these contrivances will be explained later; at present the novice is not concerned with them, but should use the lens with the largest opening obtainable. The exposure having been made, the shutter is pushed back and the slide removed from the camera. The plate is now ready for development, which may be carried out at any convenient time.

DEVELOPING.

As the plate is highly sensitive to light, it must be examined in a room from which white light is excluded. Fortunately, the plate is not equally sensitive to rays of every colour. Red light, for instance, has practically no effect on an ordinary plate. Photographic operations, therefore, may be carried on, without risk of spoiling the sensitive medium, in a room lighted by a red lamp or a window covered with ruby fabric or paper. Such a room is called a dark-room or developing-room. Supposing a gelatino-bromide plate has been used, there will be no perceptible change after exposure on its creamy white surface. Before any visible

result can be obtained, the plate must be subjected to the action of a developing solution, which will bring out the image already formed there by the action of light. This operation of bringing out the latent image is known as developing.

WHY DEVELOPMENT IS NECESSARY.

The principle of the developing process may here be briefly explained, without going into any abstruse questions of theory, which will be dealt with later. The gelatine emulsion with which the plate is coated contains a sensitive salt known as silver bromide. When the plate is exposed, the particles of silver bromide reached by the rays of light are affected more or less according to the amount of light or shade in the picture, and undergo a definite change. It is not necessary to describe the exact nature of this change; the point of greatest interest to the photographer is that those parts of the silver bromide exposed to light have become extremely easy to reduce to a metallic state, while the unexposed portion is far less readily reduced. The developing fluid, or developer, is a solution of a chemical compound, or a combination of different compounds, which has the effect of reducing the silver contained in the bromide emulsion, and leaving it in the state of a dark metallic deposit on the surface of the plate. This deposit, thicker or thinner in parts according to the varying lights and shades of the image, forms a perfect representation of the original object or view, except that the lights and shades are reversed.

SENSITIVE MATERIALS.

The readiness with which light will act on a sensitive plate is regulated by what is known as the rapidity or speed of the plate. All plates do not possess the same degree of sensitiveness to light. To suit different purposes, plates are manufactured of widely varying sensitiveness, ranging from the very slow ones used in process and photo-mechanical work, to the lightning rapidity of those employed for instantaneous and flashlight photography. The sensitive material need not necessarily be coated on a glass support. Cellu-

loid and paper films, and films consisting of several layers of gelatine only, may now be obtained, both flat and in continuous rolls. In cases where the weight of glass plates is objected to, films may be used without hesitation, and often with greater convenience.

DEVELOPING WITHOUT A DARK-ROOM.

The necessity of a dark-room for developing purposes has long been insisted upon, but it has now been demonstrated that plates and films may be successfully

dish under the cover of a focussing cloth or changing bag, so that light may not reach it until it is actually in the machine or coloured solution. This does not apply to Daylight roll films, of various makes, which are so provided with a surplus length of black paper at the end of the roll that they may be inserted in either camera or developing machine without recourse to a dark-room. The beginner, however, is strongly recommended to adopt the more general method of developing in the dark-room. A better grasp of

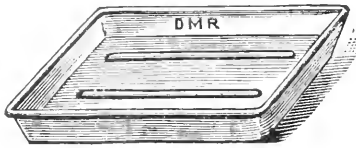

Fig. 11.—ORDINARY DEVELOPING DISH.

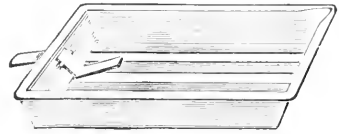

Fig. 13.—DISH WITH LEVER.

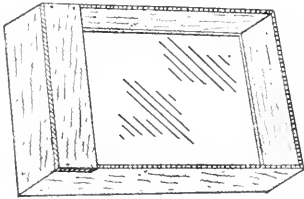

Fig. 12.—GLASS-BOTTOMED DISH.

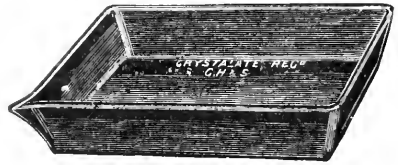

Fig. 14.—LARGE DISH FOR FIXING.

developed in full daylight by means of special contrivances. Among these may be mentioned developing machines for holding the plate or film in a light-tight receptacle, into which the developer and other solutions are poured in turn by means of an outside funnel, while the progress of development is judged by looking through a pair of small ruby windows in the front and back; others in which a length of film is drawn through the developer, and kept in motion by rollers operated by handles placed outside; and solutions or compounds for staining the film of the plate, or the developer, to a ruby or other non-actinic colour, the stain being afterwards removed by washing. In most cases, however, the plate has to be placed in the machine or

the subject will be obtained by this means, besides which there are numerous things that can be done in the dark-room that cannot be done with developing machines and similar devices, useful as these are under favourable conditions.

MATERIALS REQUIRED FOR DEVELOPING.

The articles needed for development on the usual plan are comparatively few in number. A flat dish of metal, ebonite, or celluloid, of sufficient size to hold the plate; a larger porcelain dish for the fixing solution; a washing tank, or other suitable arrangement in which to wash the plates before and after fixing, and a ruby lamp are the primary essentials. Next in importance come the graduated measures, in which the different solutions

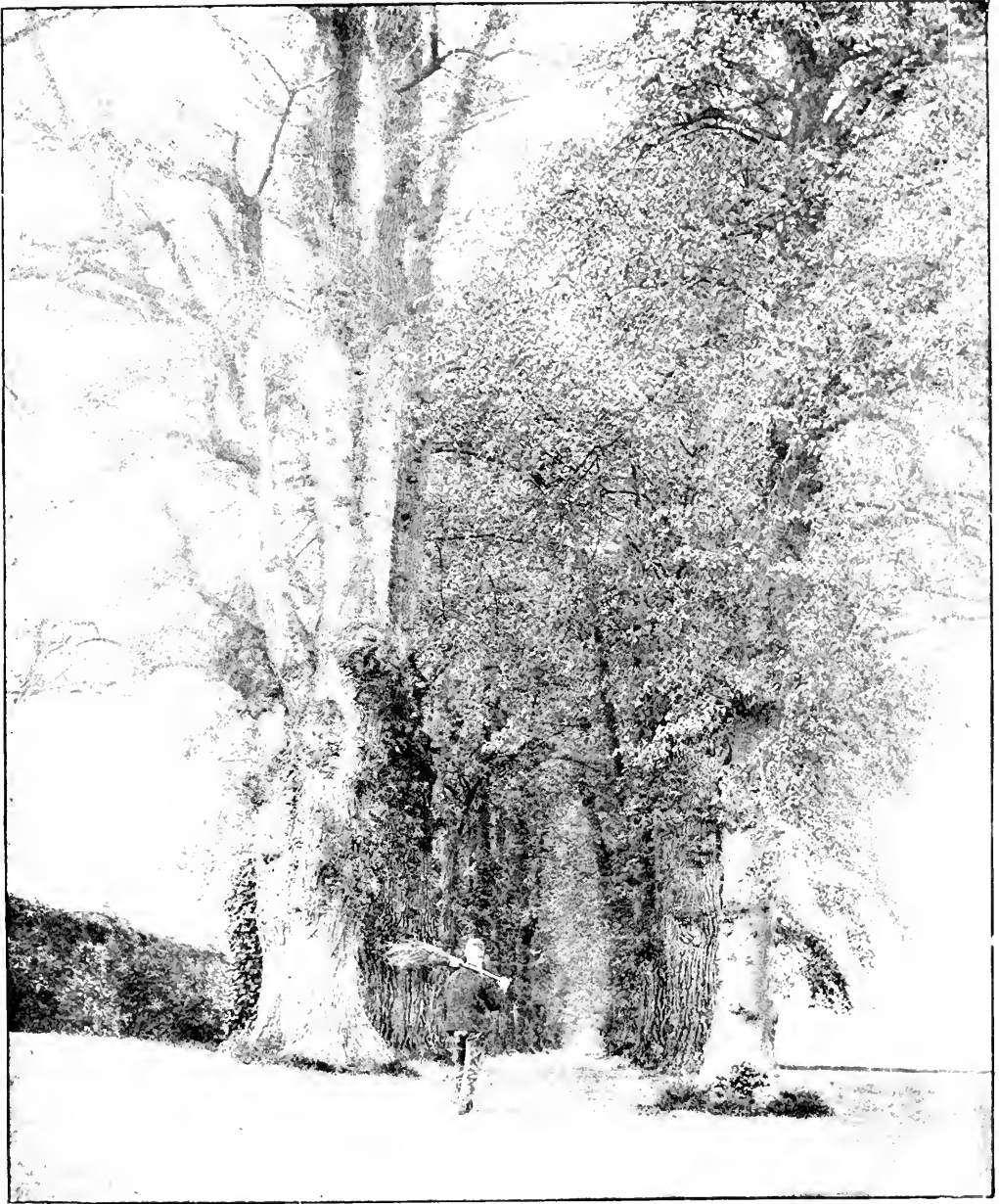

REPRODUCTION OF PLATINUM PRINT AFTER DEVELOPMENT

are weighed; these may be of glass or celluloid, the former being more frequently used. The chemicals required for all the operations of development and fixing might well bewilder the novice, on account of their number and complexity; but only those which are really indispensable need be referred to at the present stage. The different items will now be explained in detail.

DISHES.

The size of the developing dish depends on that of the plate to be used, although several small plates may be developed in

side for raising the plate when it is desired to remove it for examination; another form, which enjoyed considerable patronage at one time, is provided with a glass bottom, and has at the side a trough-like continuation, by which it is possible to raise both dish and plate to a nearly vertical position, to enable progress to be judged by looking through it against the light of the ruby lamp, the developer meanwhile running into the trough provided. The dish for the fixing solution is of a different description, though any kind of dish may be used. A large, deep porcelain or stone-

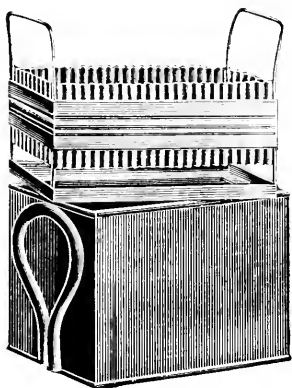

Fig. 15.—WASHING TANK AND RACK.

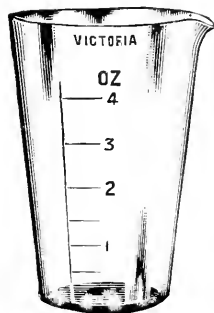

Fig. 16.—GLASS MEASURE.

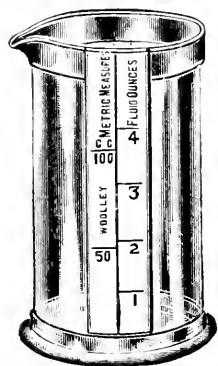

Fig. 17.—CELLULOID MEASURE.

a dish intended for a larger size. The principal sizes of plates are as follows: $4\frac{1}{4}$ in. by $3\frac{1}{4}$ in. (quarter-plate); 5 in. by 4 in.; $6\frac{1}{2}$ in. by $4\frac{3}{4}$ in. (half-plate); $7\frac{1}{2}$ in. by 5 in.; 8 in. by 5 in.; $8\frac{1}{2}$ in. by $6\frac{1}{2}$ in. (whole-plate); 10 in. by 8 in.; 12 in. by 10 in.; and 15 in. by 12 in. Of these, the quarter-, half-, and whole-plates are the most popular sizes, the 5 in. by 4 in. also being in favour. Developing dishes are made in ebonite, xylonite, celluloid, and enamelled metal, sufficiently large to suit each of the sizes mentioned. They may be obtained in porcelain, but this material is hardly so suitable, on account of the greater amount of light reflected through the back of the plate. Different patterns of developing dishes are illustrated by Figs. 11 to 13. One of these, Fig. 13, highly praised by some photographers, has a lever at the

ware vessel is, however, most suitable, and should be of sufficient size to hold half a dozen or more plates at once (see Fig. 14). Some photographers prefer to use a grooved tank of metal or stoneware, in which the plates are stood in an upright position. A similar tank, provided with a syphon arrangement to carry off the water, is used for washing the negatives, both before and after fixing (see Fig. 15).

MEASURING GLASSES.

In order that the operations of development may be performed with perfect uniformity and accuracy, it is necessary to have some means of measuring the various solutions employed. For this purpose graduated measures are employed, made of glass, mica or celluloid, having a scale engraved on the side which indicates cer-

tain quantities (see Figs. 16 and 17). Two of these measures, one holding 4 oz. and the other 2 oz., will be all that are required at first. Smaller ones, indicating minims, are also made for gauging very small quantities of solution. If it is intended to make up all the chemical solutions, instead of buying them—which is, of course, the most economical way—a pair of scales and weights will be required. Suitable ones are shown by Fig. 15.

PYRO-SODA DEVELOPER.

There is a very wide range of choice in selecting a developing agent, but for the present the pyro-soda developer alone will be dealt with. This is the developer now most in use; and the novice will probably

it with water, dissolve in it 2 oz. of sodium sulphite and 2 oz. of sodium carbonate. The latter is ordinary washing-soda, which may be used if pure; but as it is frequently adulterated, it is better to obtain the pure salt at the photographic dealer's. Some difficulty will probably be found in dissolving these two chemicals unless warm water is used; but warm water should on no account be employed for the pyro solution. The bottle containing the two soda salts in solution is labelled "Pyro-soda No. 2." When this is cold, the developer is ready for use. Take the remaining pint bottle, and measure into it 3 oz. of the pyro stock solution; then fill it up with water, and label "Pyro-soda

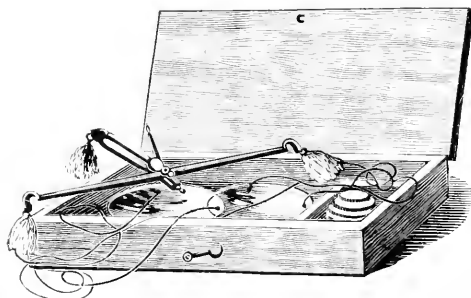
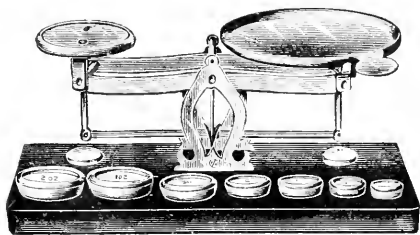

Fig. 18.—COUNTER SCALES AND WEIGHTS AND APOTHECARIES' SCALES AND WEIGHTS.

find it easiest to work with, until some experience has been gained. For the pyro-soda developer obtain pyrogallic acid, 1 oz.; potassium bromide, 1 oz.; potassium metabisulphite, 1 oz.; sodium sulphite, 1 lb.; sodium carbonate, 1 lb.

MAKING UP THE DEVELOPER.

First obtain a stoppered bottle of 12 oz. capacity, and two others each holding 1 pint. Fill the 12-oz. bottle with water (boiled or distilled water is the best, although not absolutely necessary), and empty into it the ounce of pyrogallic acid, which will dissolve almost immediately. Next weigh out separately 60 grains of potassium bromide and 50 grains of potassium metabisulphite, and add these one at a time to the solution of pyrogallic acid shaking well till dissolved. Label this "Pyro Stock Solution." Now take one of the pint bottles, and nearly filling

No. 1." For use, take equal parts of solutions Nos. 1 and 2, the amount taken depending upon the size of the plate to be covered; for a half-plate 2 oz. will be sufficient.

FIXING THE IMAGE.

After the image has been developed on a sensitive plate, the remaining white or unexposed portions are still liable to be affected by the action of light, and in time discoloured, although not to the same extent as before development. In the case also of a negative from which a print or positive is to be taken, the film has to be rendered insensitive to the further action of light, since the negative will have to be exposed to a strong light in contact with a fresh sensitive surface, in order that the print may be secured. It therefore becomes necessary to remove the unexposed parts of the film,

so that the picture obtained may be made permanent. This operation is known as fixing, and is commonly effected by immersion in a solution of hyposulphite of soda. In the earlier days of photography, before the problem of fixing the photographic image had been solved, it was necessary to keep the pictures in a drawer or cupboard, away from the action of light, and to examine them only by lamplight or very faint daylight: all this trouble is now avoided by dissolving away the unaltered silver salts in the fixing bath.

as it will not be acted on, as porcelain or earthenware generally is, by the hypo. solution.

FIRST LESSON IN DEVELOPING.

The plate having been exposed, the dark-room may be arranged for the preliminary attempt at development. The hypo. should be made up as described above, and the large porcelain dish filled. The two bottles of pyro-soda developer should be placed ready to hand. The light from the ruby lamp must be nicely adjusted, and the developing dish placed

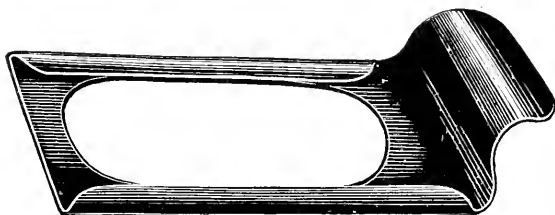

Fig. 19.—FILM HOLDER.

THE FIXING SOLUTION.

There are several reagents which have the property of dissolving out the silver salts that remain unreduced by the developer, the two principal of which are cyanide of potassium and thiosulphate, or as it is commonly called, hyposulphite of soda. The latter is now generally used for the purpose, and has the merit of being harmless, while the former is a deadly poison. Fixing is accomplished by simply immersing the negative in a solution of hyposulphite of soda for twice as long as the negative takes to become completely transparent and clear, generally about ten or fifteen minutes. The hyposulphite of soda costs very little, and may be bought in 1 lb. packets or barrels of 1 cwt. A quantity of solution should be made up at one time in a large bottle or stoneware jar with a tap, and labelled "Hypo. Stock Solution." The proportion is 1 lb. of hypo. to 4 pints of water. No special apparatus is required for fixing. A porcelain dish to hold the solution is all that is necessary. A large vulcanite dish, if it can be obtained, will prove still better,

in front of it. Next, 1 oz. of No. 1 developing solution is poured into the 2 oz. measure, and then 1 oz. of No. 2. The slide is now opened, and the first plate, supposing only one has been exposed, taken out; the slide can be refilled later, but at present should be closed and placed out of the way of splashes. The exposed plate is laid film side up in the developing dish, and the developer poured quickly over it, moving the dish so that the solution flows evenly all over the plate. The dish must be regularly rocked, so that air-bubbles may not settle on the film and to prevent uneven patches being formed. After a few seconds the image will slowly appear, and gradually become stronger. When the picture is apparently dark enough, it should be held up in front of the lamp and examined. A holder for films or plates, as shown, is very convenient, as it avoids the necessity of wetting or staining the fingers. Fig. 19 shows a holder for films but those for plates are similar. A perfect reversal of the original should be presented in which the lights are indicated by opaque patches and the

shadows by unaltered or slightly altered white emulsion. The plate must be replaced in the developer, and the rocking continued till a slight veil forms over the white portions or shadows, and the rest of the negative looks quite dark and obscure, with the image distinctly showing. The negative is then rinsed for a few minutes under the tap, or in a pail of water.

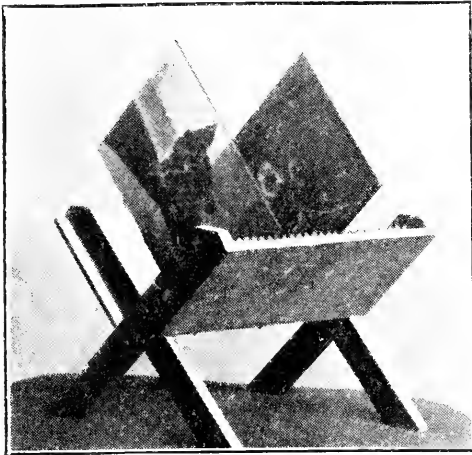

Fig. 20.—WOODEN DRYING RACK.

FIXING, WASHING, AND DRYING.

The negative may now be placed in the fixing-bath, in which it is allowed to remain for about fifteen minutes. It is finally washed under a tap, from which the water is allowed to run gently for about one hour. This may be done in the developing dish, first washing it well out, or in a proper washing tank. After washing, the plate is softly rubbed with a tuft of cotton-wool, to remove sediment or grit, and stood up to dry in any place free from dust. A drying-rack is a great convenience for this purpose; this is a grooved wooden or metal support made in various forms, holding a dozen or more plates at once (see Fig. 20). If, however, a washing tank is used of the pattern shown in Fig. 15 the plates may be dried in the rack provided with the tank. This is a convenience where time is a consideration, since the rack and negatives simply need lifting from the washing water.

PRINTING.

As already pointed out, the picture obtained by the development of a gelatine plate is reversed as regards light and shade, and while in this condition is called a negative. It is therefore necessary, in order to obtain an exact presentment of the subject photographed, to expose the negative in contact with another sensitive surface. The light passes through the transparent portions of the negative, reproducing them as patches of different degrees of darkness on the sensitive film behind; the darker parts of the negative, of course, obstruct the action of the light, and produce an oppo-

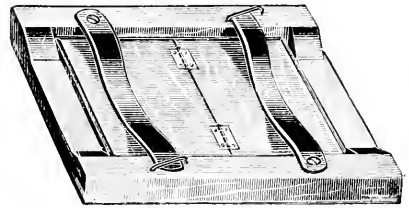

Fig. 21.—PRINTING FRAME.

site effect upon the film. The result is the production of what is called a positive; that is, a picture correct as regards light and shade. The positive picture, unlike the negative, which is invisible until developed, changes colour perceptibly under the action of light, growing gradually darker and darker. The progress of the printing may thus be easily gauged, and the paper removed as soon as the print is sufficiently dark. This process is generally carried out on a sensitized paper surface, and is known as "printing" or "printing out."

THE PRINTING FRAME.

The ordinary arrangement for obtaining prints from a negative is known as a printing-frame. This consists of a strong wooden frame with a rebate to hold the negative plate, and a hinged back kept closely pressed down, when in use, by a couple of metal springs (see Fig. 21). The frame should be provided with a piece of plain glass to diminish the risk of breaking

the negative by a chance fall. The hinged back being removed, the negative is placed on the top of the glass, film side upwards; and in contact with the negative, film side downwards, a piece of sensitised paper is laid. A sheet of rubber backing should be placed over this, to equalise pressure and guard against damp. The hinged back is finally replaced and the springs fastened. The frame is then exposed to light for the purpose of printing.

SENSITIVE PAPER FOR PRINTING.

There is quite an array of materials and reagents employed in the printing operation. The first to be considered is the sensitive paper. The principal printing-out papers—that is to say, those on which an image of full depth is obtained in the printing-frame—are plain salted paper, albumenised, gelatino-chloride, collodio-chloride, and ferro-prussiate. The novice is advised to begin with albumen or printing-out paper, as it is by far the easiest to manipulate. There are a large number of different brands and makes; but until some experience has been gained, the beginner cannot do better than purchase a packet of glossy P.O.P. This can be obtained either in large sheets put up in tubes, or in packets of ready cut pieces, the latter being the more convenient form.

FIRST LESSON IN PRINTING.

For experimental purposes, it is advisable to borrow a good negative, as the use of a bad or unsuitable negative will hinder the attainment of satisfactory results. A good negative having been obtained, it is placed in the frame with the sensitive paper in contact. The frame is then laid face up, outdoors, in a bright light. Diffused light is necessary, direct sunshine being quite unsuitable, except in the case of very dense or opaque negatives. After the frame has been exposed for about five minutes, it is taken in the left hand, and held in the shadow of the body for examination. This is done by unfastening one spring and carefully lifting the back, when a portion of the picture can be examined by lifting part of the paper (see Fig. 22). Care must be taken not to shift the paper,

nor to expose it long to the light. If not dark enough, the spring must again be fastened, and the frame replaced. The other half of the paper can also be examined by opening the second spring, but the two sides must not be opened at once, until the print is finished. As the print loses a certain amount of colour in toning and fixing, it must be left exposed until it is much darker than the finished photograph is desired to be. Three or four prints should be obtained of different depths, and careful note taken, for future reference, of the correct depth of printing.

TONING AND FIXING THE PRINT.

The print, as it comes from the frame, is still sensitive to light in the unexposed or white portions, and would darken in those white portions if not freed from the unaltered silver and made permanent by fixing. This fixing is done by immersing the print in a solution of hyposulphite of soda, in the same manner as with a plate. The fixing solution for prints, however, is only about half the strength of that used for plates. Now, a print merely fixed with hypo. assumes a most disagreeable tint, a kind of yellowish-brown, and to remove this objectionable colour the print is immersed in the toning bath. For toning P.O.P. in the ordinary manner, all the chemicals required to be purchased are a 15-grain tube of gold-chloride and 1 oz. each of ammonium sulphocyanide and lead acetate. One 2-pint and three 10-oz. stoppered bottles will also be needed.

TONING AND FIXING SOLUTIONS.

The simplest method of toning is by using the combined toning and fixing bath, in which, as its name indicates, both fixing and toning are done with the same solution. It is true that there are certain objections against it; among others, a lack of permanency in the resulting prints. These considerations, however, may be safely ignored by the beginner, until further progress has been made. The following is a good formula for stock solutions:—No. 1, Hypo., 12 oz.; water, 2 pints. No. 2, Ammonium sulphocyanide, 1 oz.; water, 10 oz. No. 3, Lead acetate, $\frac{1}{2}$ oz., water 10 oz.

No. 4, Gold chloride, 15 gr. : water, 10 oz. These are made up separately in the four bottles, and labelled with their respective numbers. For use, take No. 1, 7 oz. : No. 2,

FIRST LESSON IN TONING.

Three or four prints being available, and the combined toning bath having been



Fig. 22.— EXAMINING THE PRINT.

1 oz. : No. 3, 1 oz. : No. 4, 1 oz. : mixing them in the order given. This bath will fix the print, and at the same time give tones from red to dark brown.

made up as described, the first attempt at toning may be made. For present purposes, the fixing dish used in developing, well washed out, may be employed for

toning, as the combined bath contains hypo., and contamination of the prints is therefore unlikely. For serious work, a separate set of porcelain dishes must be obtained. Before pouring the toning bath into the dish, the prints should be washed. The dish is filled with clean water, and the prints immersed face downward, one at a time. They are kept moving about, to prevent them from sticking together, and after a few seconds the water is poured off, and the dish again filled. Three or four changes of water must be made, until the last to be poured away is free from all signs of milkiness. This operation is intended to remove the free silver nitrate, acid preservatives, and other soluble salts. The toning solution is poured into the dish and the prints immersed in this, rapidly separated, and kept in constant motion, by continually bringing the bottom print to the top. The prints will go at first to a dirty yellow colour, and lose depth considerably, but will shortly begin to acquire a pleasing brown tone. A definite time can hardly be given for this, as it depends considerably on the character of the negative from which the prints are obtained, and several other factors. It should not take much more than ten or fifteen minutes. When a print assumes a satisfactory warm brown colour, which can be ascertained by looking at the surface, it is removed and placed in a dish filled with clean water. With such a small number as four, the prints will most likely be finished at the same time, and may be removed all at

once to the palm of the hand while the toning solution is poured off; after which they are replaced in the dish, and washed under the tap, using a gentle stream of water, for one hour. It should be noted that 10 oz. of the toning mixture is sufficient to tone an ordinary shilling packet of paper. A smaller quantity, in the same proportions, should be used when only one or two prints are to be toned; but there must always be enough to cover the prints. The combined bath may in many cases be used again, until exhausted, though as a rule it is better to use a fresh bath each time. The prints will dry a shade darker than they appear when wet. They should be laid out, face upwards, on clean blotting-paper, and allowed to dry spontaneously.

CONCLUDING REMARKS.

The simple directions given in this section for the operations involved in the production of a photograph will familiarise the reader with the essential principles of the art. They are to be regarded, however, merely as stepping-stones, providing a way to the acquisition of more complete knowledge of the subject. It is not even necessary that the whole of the suggested experiments should be actually carried out, so long as the descriptions are carefully read and their meaning and method clearly understood. Serious work may then be undertaken in the light of the more detailed instructions which follow.

CAMERAS AND ACCESSORIES.

A BEGINNER'S OUTFIT.

AN expensive and elaborate outfit are certainly not necessary for the beginner in photography, but, on the other hand, very cheap outfits are often little better

a very low price ; but here, also, the advice of an experienced friend is necessary, unless the buyer is prepared to run the risk of getting perhaps a bargain, but possibly useless rubbish. A good camera should be

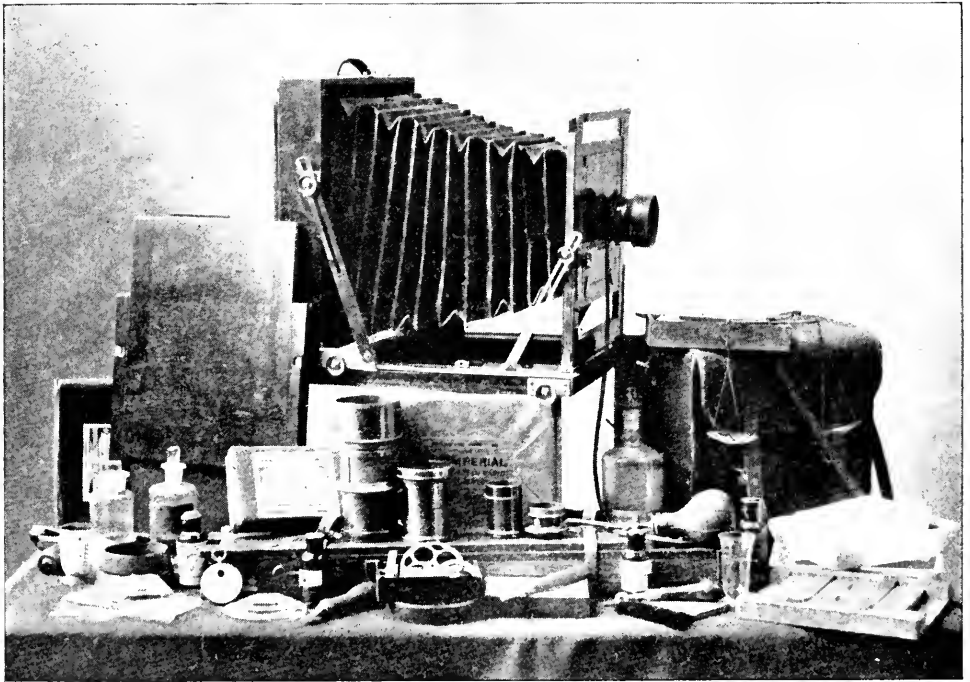

Fig. 23.—TYPICAL OUTFIT FOR OUTDOOR AND GENERAL WORK.

than toys. The beginner should seek the help of a photographic friend, state the sum that is to be laid out, and be guided by his advice. If this plan cannot be adopted, buy of any well-known maker the best that can be afforded. Good second-hand apparatus can often be purchased at

strongly made and should not show signs of ill usage ; it should be compact, but not at the expense of rigidity, and the frames should be dovetailed and preferably brass or aluminium bound. The movable parts should fit firmly without working stiffly, and, when screwed up, there should be

absolute freedom from vibration. Fig. 23 illustrates a typical outfit with all accessories for outdoor and general work.

MOVEMENTS AND FITTINGS OF THE CAMERA.

For general photographic work the camera should have the following movements: A double extension—that is, both a sliding board or frame and an extending base. The total extension should be equal to or greater than twice the diagonal of the plate to be used with it; 18 in. for half-plate, or 12 in. for quarter-plate. There should also be an extra movement

moving the camera, is necessary. A camera that must be placed on its side, or in which the slide must be fastened with turn-buttons in order to effect this, is old-fashioned. Focussing should be done by rack and pinion, and, if the camera is to be used for copying and other indoor work, it is better that the focussing should be done by moving the back part. Conical bellows cameras are usually more compact, but for general work square bellows should be chosen. A small circular spirit-level

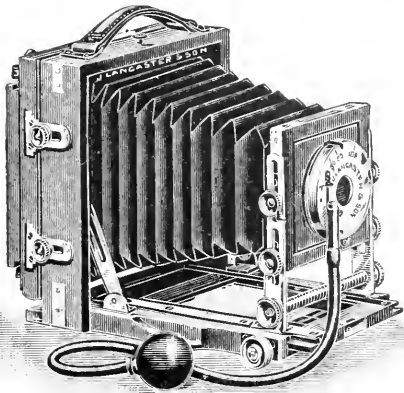

Fig. 24.—TYPICAL LANDSCAPE CAMERA.

of back or front, making it possible to bring the lens and the plate close together over the centre of the base, for use with short focus lenses. The frame carrying the dark-slide or plate-holder should be movable, so that it may be placed at an angle to the front. This is called a swing back. Not only should it swing backwards or forwards, to bring the plate upright when the camera is tilted either up or down, but it should swing from side to side, to accommodate the focus. The lens should be capable of being moved up and down and clamped firmly in any position. This rising front is far more essential than a sliding front, or movement from side to side. A reversing back, which makes it possible to place the slide (which should run in grooves) in either a vertical or a horizontal position without

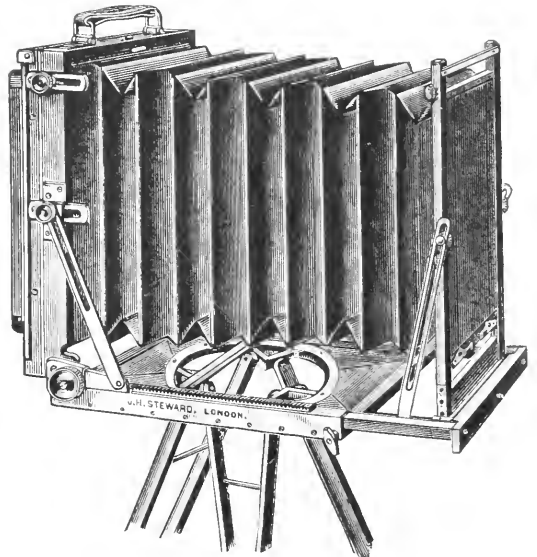

Fig. 25.—SQUARE BELLOWS FIELD CAMERA.

should be attached to the top of the back frame, and a plumb indicator to the side of the swing back. It should be seen that these are correctly and truly fitted, as otherwise they are worse than useless. The dark slides should be of double book form, and in accurate register with the focussing screen. There should be no loose parts. Figs. 24 to 28 show typical field cameras, having distinctive features, all being serviceable and each one excellent for special purposes.

USEFUL SIZE FOR CAMERA.

As regards size, a half-plate will be found the most useful. A whole-plate camera is too bulky, and a quarter-plate rather too

small for figure work. To economise plates, the dark slides—of which there should be three—should be fitted with carrier frames, for holding smaller plates. These frames may be of a size of 5 in. by

plane as the half-plate. The tripod should be adjustable from a height of 5 ft. to 3 ft. 9 in. It must, when well screwed up, be thoroughly firm, both to downward pressure and to a sharp twist. It should be about 20 in. long when folded up. Second-hand cameras with stand and three dark slides, all of fair quality and condition, can often be purchased.

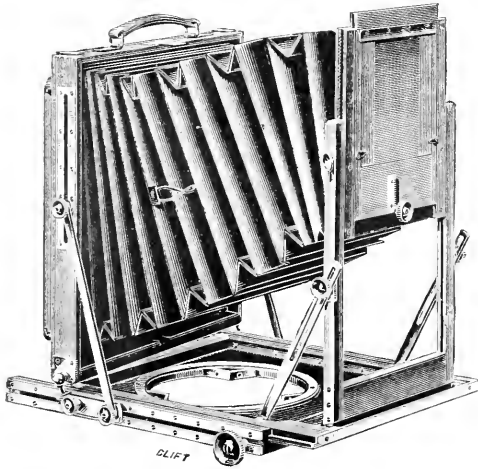

Fig. 26.—FIELD CAMERA WITH HIGH RISE OF FRONT.

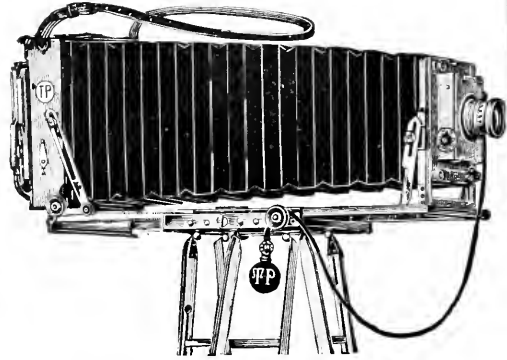

Fig. 28.—LONG EXTENSION FIELD CAMERA.

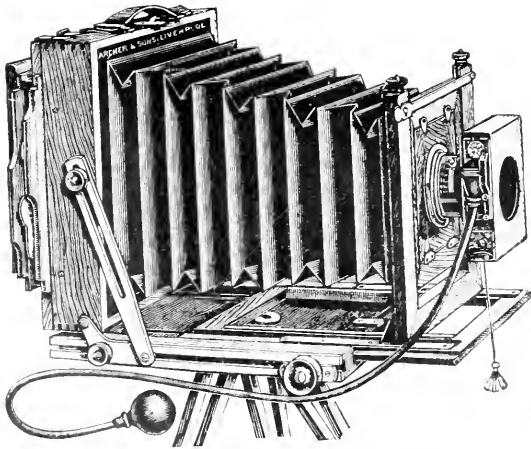

Fig. 27.—FIELD CAMERA WITH ROLLER BLIND SHUTTER.

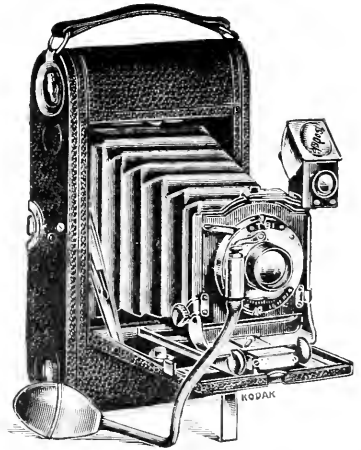

Fig. 29.—FOLDING HAND CAMERA FOR FILMS.

4 in., for quarter-plate, and for half-quarter-plate or midjet pictures; and they are made of wood $\frac{1}{2}$ in. thick, with a $\frac{1}{2}$ in. by $\frac{3}{8}$ in. rebate around the outer edges, and a similar rebate around the inside edges, but on the reverse side. This should bring the plate, which is laid in face down, flush with the slide rebate, or in the same

HAND CAMERAS.

The hand camera seems to be the most popular amongst beginners, and when used with due care and discretion it quite justifies its popularity. But unfortunately some people are carried away by its apparent simplicity. It seems to remove all difficulty about judging the exposure, there

ing nothing to do but press a button, pull a cord, or squeeze a ball. The plate is thus exposed, though seldom is the exposure correct. A landscape on a bright day, a portrait in an ordinary room, or a dimly lighted interior will all receive the same exposure, and it is only by chance a good picture is got. With proper care,

SELECTION OF LENSES.

The selection of the lens will probably give the beginner more trouble than any other part of the apparatus. Lenses should always be tested by an expert before purchasing; mere examination is useless. Some methods of testing, which give

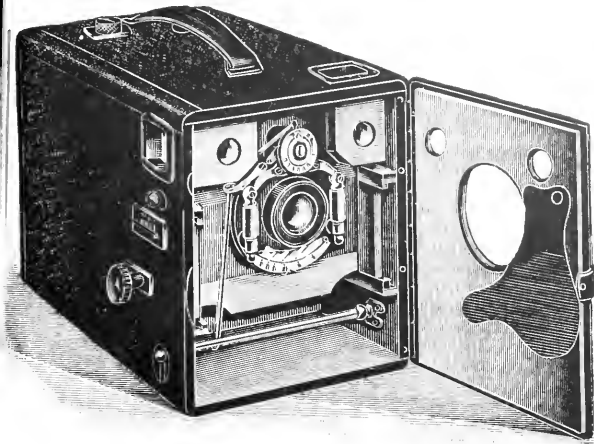

Fig. 30.—MAGAZINE HAND CAMERA.

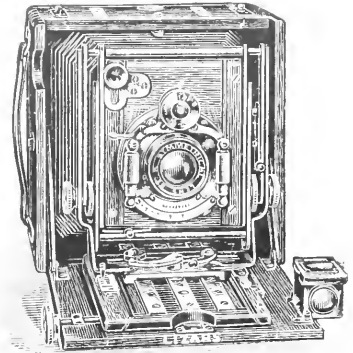

Fig. 32.—FOLDING HAND CAMERA FOR PLATES.

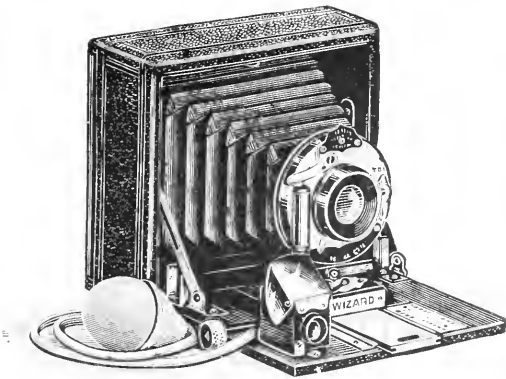

Fig. 31.—FOLDING CAMERA WITH PNEUMATIC RELEASE.

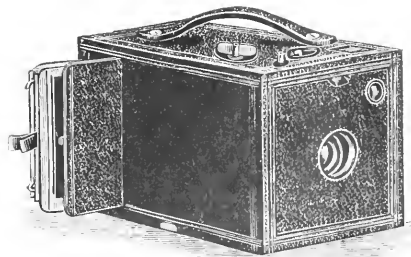

Fig. 33.—FOCUSING HAND CAMERA FOR PLATES.

however, the hand camera will do work as good as the stand camera; in fact, many of the best workers prefer a hand camera on account of its lightness and portability. Figs. 29 to 33 show a small selection of standard patterns, but hand cameras will be fully dealt with in a later section of this book.

a very fair idea of the value of a lens, are given on another page of this book. Such tests require some experience to carry them out properly, and the results obtained should be verified by other means. A corrected lens, half-plate size, suitable for a beginner, can be purchased for from one to two guineas. Though periscope lenses are specially suitable for some work, the fact that they do not give a sharp photographic image makes them very unsuitable for general purposes. For all round

photography, rectilinear lenses are the best. They are not so rapid as portrait objectives, but are fast enough for most work, and are usually twice as quick as a single lens. In the latter, straight lines occurring at the margins of the field of the lens are distorted either outwards or inwards, according as the stop is placed in front of or behind the lens (see Figs. 34 and 35). For outdoor work or for portraiture this distortion is of little consequence, but for architecture, copying, and

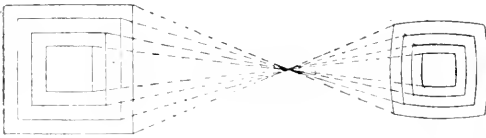

Fig. 34.—PINCUSHION DISTORTION WITH STOP BEHIND LENS.

some other work, it would be a serious matter. If one lens is to serve all purposes, it will be advisable to obtain one in which the two lenses forming it are of different foci. This will be equivalent to having three single lenses. When a half-plate lens is used to take a quarter-plate

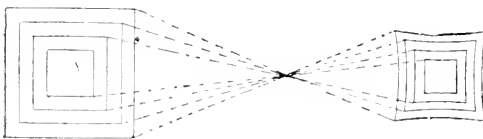

Fig. 35.—BARREL DISTORTION WITH STOP BEFORE LENS.

picture, only a portion of the subject or view can be got on the plate, unless the camera is moved farther away, and this may not be possible. Hence it becomes necessary to use a shorter focus lens requiring less extension of the camera, or a lens that gives an image of the same size nearer to the object. It therefore follows that if this lens were used on the half-plate, the amount of subject included, instead of being the same as that on the half-plate with an ordinary lens, would be

still greater, and the lens would be termed a wide-angle lens. This is made clear by Fig. 36, which is a picture taken with a wide-angle lens. With a lens of normal angle the picture would have been limited to that portion within the white lines. Wide-angle is only a comparative term applied to a lens when it is used to cover a plate the diagonal of which is greater than the focal length of the lens.

CHANGING BOXES

In place of a set of dark slides some workers prefer to use a changing box.



Fig. 36.—ANGLE OF VIEW TAKEN IN BY LENS.

This is a magazine holding a number of plates, each of which can be exposed in turn. The changing of the plates is effected by means of a leather bag. A typical changing box is shown by Fig. 37: it fits the camera in the same way as an ordinary dark slide. Several somewhat similar arrangements, on the same principle, may be obtained for use with films.

CARE OF THE TRIPOD STAND.

The tripod will want the least attention of any part of the photographer's apparatus, and save for an occasional rub with a cloth on which a little boiled linseed oil has been applied, no further trouble need be taken. Should the sliding part work stiffly, a little blacklead may be rubbed on; but, unless it is very stiff, it should not be so treated, as it will work loose in

ime, and however little blacklead is put on it, will detract from the appearance of the tripod. If the tripod head is of metal, it should be neatly covered with chamois leather to prevent the baseboard of the camera becoming scratched. The loss of the tripod screw may be a frequent occurrence if it is not fastened to the head with a short chain and swivel. The swivel should turn on a ring, like the top of an ordinary watch-key, and it will prevent the chain becoming twisted when screwing on the camera. To prevent the tripod legs slipping apart on a smooth floor, place under each leg a piece of indiarubber or cork, a few pieces of which should always

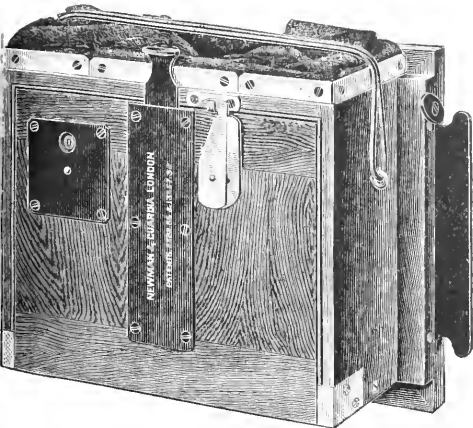

Fig. 37.—CHANGING BOX.

be kept in the camera case. When screwing the camera on to the tripod, take care that the lens is just over one of the legs; the back of the camera will then be over the space between the other two legs, and thus leave the operator plenty of room to manipulate the camera comfortably.

CARE OF THE CAMERA.

The camera requires to be kept in good condition, as good work is next to impossible unless the camera be kept scrupulously clean and absolutely light-tight. Examine the camera at intervals to see that no part has come unglued, and also for tiny holes in the bellows. To find the

latter, take out the focussing screen, and cover the head and just the back of the camera with the focussing cloth, taking care not to let any part of the bellows be covered with the cloth, for reasons that will at once be apparent. When the eyes have become accustomed to the darkness, get someone to hold a light—such as a candle or lamp—moving it round the bellows. A pinhole in the bellows will quickly be seen, and, no matter how small, must be stopped by gluing tightly over it a small piece of black paper or linen. Should any of the dead black be rubbed off the inside of the camera, it should at once be re-blacked with the material described on another page. The rack and pinion, clamping screws, and hinges on the camera should all be oiled occasionally with a little best machine oil. A soft chamois leather should always be kept expressly for the camera and dark slides, as not a scratch or a dirty mark should ever be seen on either. From time to time the camera should be dusted inside with a soft camel hair brush, first removing the lens. This dusting should never be done just previous to using, as it is likely to raise the dust, which will settle on the photographic plate and cause small transparent spots in the negative, known as pinholes. At regular intervals the bellows should be well brushed.

CARE OF DARK SLIDES.

The dark slides do not require much attention. If they are light-tight and kept clean, that is all that is required. Like the camera, however, they should be well dusted out, as any dust in them may cause pinholes in the negative. If the shutters work stiffly, a little blacklead should be put on the rebates of the shutters. The shutters will become stiff if the slides are kept in a damp place, as then the wood will swell. The dark slides should always be kept wrapped in protectors, which may be bags made of baize. These will keep the slides from being scratched and knocked about, and from the light—a point that should always be looked to, no matter how light tight the slides may be.

CARE OF LENSES.

The lens is the most valuable and delicate part of the whole photographic outfit, and a small case should be provided for it, to prevent it being knocked about and to protect it from the dust. The less dusting a lens has consistent with cleanliness the better: any dust that may get on it should be carefully wiped off with an old soft silk handkerchief, previously washed in clear water and dried away from dust, as the slightest speck of dust on the handkerchief may scratch the beautiful surface of the glass. The silk handkerchief used for

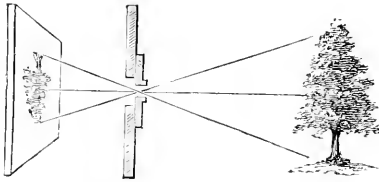

Fig. 38.—DIAGRAM ILLUSTRATING PRINCIPLE OF CAMERA OBSCURA.

When the lens is not in use, the band should be kept over the slot in order to exclude both dust and air. An Iris diaphragm should be chosen in preference to either Waterhouse or rotating stops, as the Iris is undoubtedly superior in every way, and well worth the extra money charged for it. With these there are no loose parts liable to be lost, and the aperture can, if desired, be altered during the exposure without fear of vibration. After use unscrew the lens from the camera, and put it away in its case. The temperature of the lens should not be below that of the

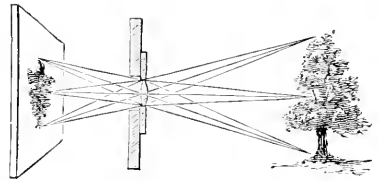

Fig. 39.—DIAGRAM ILLUSTRATING PRINCIPLE OF SIMPLE LENS.

dusting the lens must not be used for anything else. The lens case may be made of cardboard and lined with chamois leather. It can be made either at home or by a professional casemaker. The latter should have proper measurements given him, as the lens should not go out of the owner's hands, if he values it as he ought. Sometimes the combinations of a rectilinear lens will require dusting between the glasses. To do this, only one combination at a time should be unscrewed, and, when dusted, should be replaced before the other is taken out, so as to guard against mixing them. It was at one time customary, when the lens was fitted with Waterhouse stops, to keep a flat indiarubber band around the lens tube, so that when using the lens at full aperture, the band could be slipped over the diaphragm slot, and so prevent light entering. Nowadays, however, this is seldom necessary, as lenses are almost invariably supplied with a "full aperture stop." This, although not really a stop, effectually stops any extraneous light entering.

atmosphere in which it is to be used, otherwise the vapour in the air will condense on the glass and produce fog in the negative. Should this occur, and sometimes in a cold studio in the winter it is unavoidable, the lens should be slightly warmed by the fire, unscrewing one lens so that the air may escape.

THE PRINCIPLE OF THE LENS.

The lens is the most important part of a photographic camera, but its requirements are not generally understood. There is no necessity for the novice in photography to start with a high-class lens, for, in his early attempts, he will probably succeed equally well with a very inferior one. Assuming that the beginner's knowledge of lenses is probably of the crudest kind, the following information concerning the different varieties, and the work that can be done with them, should be helpful. It is quite possible to make a fairly good picture without the use of a lens; for instance, suppose that a darkened room is entered and that a hole is pierced through the shutter of the

window, and the edges bevelled off so that the hole shall not be tubular; on the wall facing the hole will be found an inverted image of the scene outside. From every point in the scene, which is here shown as a tree, a ray of light emanates, passes through the hole, and lights up the wall with its own colour. Fig. 38 shows the direction of the rays and how the image is inverted. The room just described is a perfect camera obscura, and one that might be made practical use of in photography but for the reason that the hole in the shutter must have some appreciable diameter. The smaller the hole, the sharper is the definition, so that fairly good pictures have been produced with an aper-

plano-convex; c is a meniscus; d is a double-concave or bi-concave; e is a plano-concave; and f is a concavo-convex, sometimes incorrectly termed a concave-meniscus.

THE SINGLE LENS.

The photographer's single lens (Fig. 41) consists of two or more glasses cemented together and looking like one, fixed in a brass tube or "mount"; the negative element is of crown glass and the positive of flint glass cemented together with Canada balsam. The lens must be fitted with stops of some kind; the simplest form of stop is a

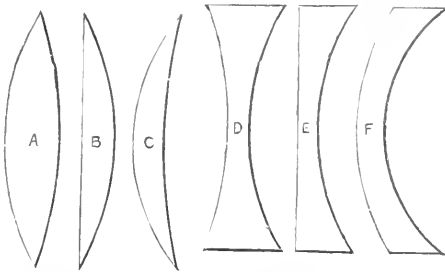

Fig. 40.—VARIOUS FORMS OF SIMPLE LENSES.

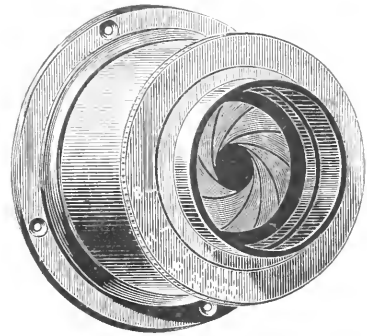

Fig. 41.—SINGLE LENS WITH IRIS DIAPHRAGM.

ture made with the prick of a needle in tinfoil or other substance. If it be very large, then every spot in the screen opposite would receive light from all directions, and, the images overlapping each other, the picture would be but poorly defined. But the difficulty remains that, if the hole is made very minute in order to get a sharply-defined image, so much light is sacrificed that the image is but faintly illuminated, and the sensitive plate used for the photograph would have to be exposed for a great length of time. If the hole is enlarged, more light is obtained, and if a suitable lens is placed in it, all the rays of light meet at a point, as shown in Fig. 39, which illustrates the simplest form of lens.

DIFFERENT FORMS OF SIMPLE LENSES.

Simple lenses from which photographic and other combinations are built up are shown in section by Fig. 40, in which A is a double-concave or bi-concave; B is a

circular plate containing variously sized holes, which may in turn be brought before the centre of the lens. The stop may be an "iris" diaphragm, consisting of a series of overlapping plates, which, by turning a ring surrounding the lens mount, causes the hole to get gradually smaller; or it may be a number of little plates with different sized holes which drop in through a slot, these being called "Waterhouse diaphragms." They all give equally good results, but the "iris" is the more convenient. In front of this comes a projecting ring called the "hood," and at the back is screwed a metal "flange," with three holes for attaching to the camera front by small screws. These lenses are suitable for landscape work or an occasional portrait in bright light, when they should be used with "full aperture" or the permanent stop. Single lenses give distortion, causing, for instance, square

objects to be represented of the shapes shown in Fig. 34 or Fig. 35, the particular kind of distortion depending on the position of the stop either before or behind the lens.

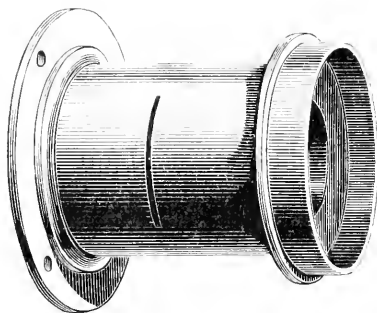

Fig. 42.—RAPID RECTILINEAR LENS FOR WATERHOUSE STOPS.

DOUBLET LENSES.

Roughly speaking, there are three forms of doublet lenses: the "rapid rectilinear" (Fig. 42), also called "rapid symmetrical," "rapid rectigraph," the "portrait" (Fig. 43 shows the Petzval or general form), and

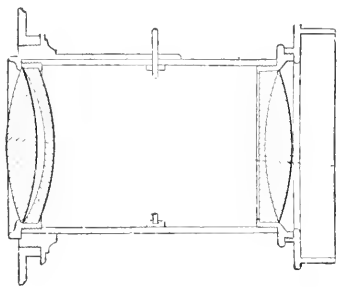

Fig. 43.—PETZVAL LENS IN SECTION.

the "wide-angle" (Fig. 44). All three are really rectilinear, or non-distorting. Each has a compound lens at each end of the tube, and generally between them are stops of one of the forms named above; the distortion of one lens should counteract exactly that of the other, the result being rectilinearity (see Fig. 45).

RAPID RECTILINEAR LENSES.

The rapid rectilinear is the most useful for all-round work. It is generally smaller

in diameter than the portrait, but larger than the wide-angle. It is slower than the portrait—that is, its full aperture is less in proportion to its focus, and so allows less light to pass, thus necessitating longer

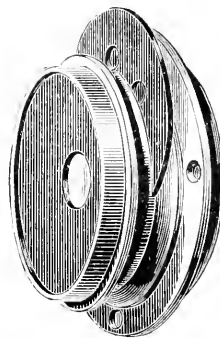

Fig. 44.—WIDE-ANGLE LENS WITH ROTATING STOPS.

exposure. In a doublet lens, either of the glasses may be removed and the other used alone as a single one, in which case it generally gives a lens of about twice the focus and covers a larger plate. When this is done it must be remembered that the value of the stops is proportionately altered. The rapid rectilinear is suitable for architectural or landscape work and

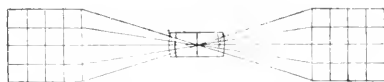
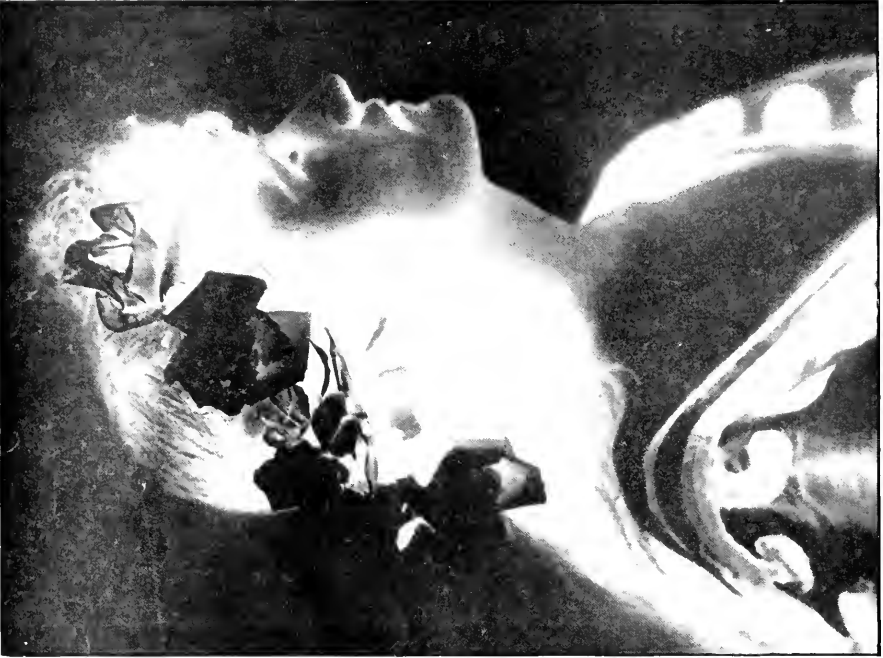

Fig. 45.—CORRECTION OF DISTORTION BY USE OF PETZVAL LENS.

for copying, and for portraiture where the light is good. For large heads the single lens is preferable. It does not usually distort, but in some cases there is a slight distortion, which will be detected by the test already described.

PORTRAIT LENSES.

The portrait lens is the least useful for general work, as it is specially constructed to give good and soft definition over only a small area with a very large aperture. It is generally fitted with a rack and pinion, by which the lens tube may be



NEGATIVE PHOTOGRAPH.

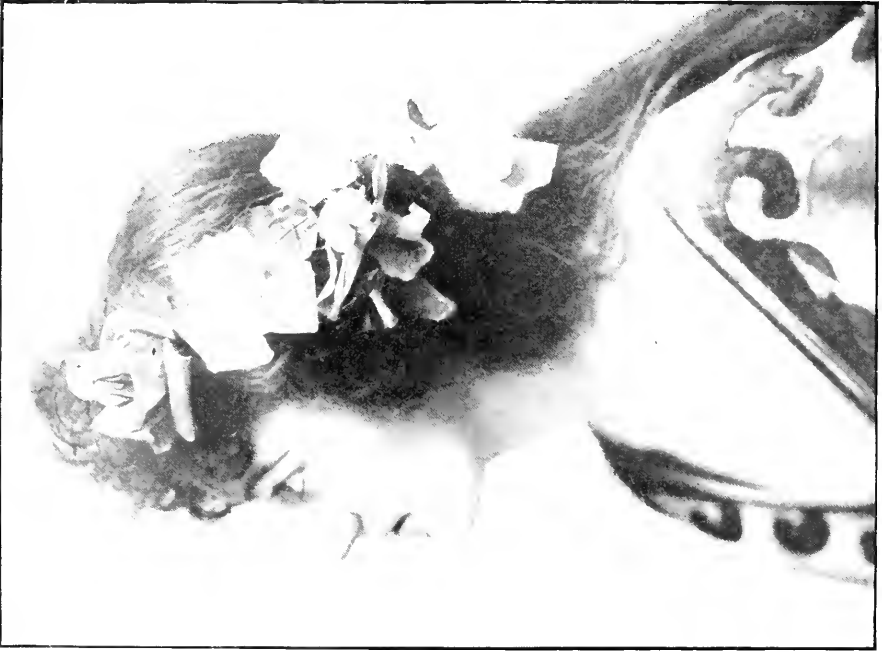

POSITIVE PHOTOGRAPH.

moved backwards and forwards in an outer tube. Such lenses are expensive if they are good. Old-fashioned ones of French make are frequently met with second-hand at a low price, but are generally of no value.

WIDE ANGLE LENSES.

The wide-angle lens is a rectilinear of short focus in proportion to the sharply defined disc it gives, or, in other words, the size of the plate it will cover. Such lenses are slow in action, and by exaggerating the perspective give a grotesque appearance to objects which be-

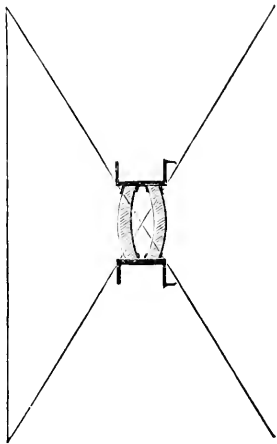

Fig. 46.—WIDE ANGLE LENS.

come foreshortened. They are a necessary evil, and should only be used in confined spaces for architectural work. The loss of light at the margins is also a serious defect. The difference between the actions of wide and narrow-angle lenses may be gathered from the illustrations in Figs. 46 and 47. From the foregoing it will be understood that any lens is a wide-angle if used to cover a plate whose diagonal is longer than the lens focus. For ordinary work the focus should be equal to the diagonal of the plate. The necessary lengths for a medium angle or focus are: quarter-plate, $5\frac{1}{2}$ in.; half-plate, 8 in.; whole-plate, 11 in.; 10 in. by 8 in., 13 in.; 12 in. by 10 in., 16 in.

CHOICE OF A LENS.

The single lens is the cheapest, and a good single lens is superior to a poor rapid rectilinear. When only one lens can be had, choose the rapid rectilinear. If two, the rapid rectilinear and the wide angle. It is an advantage, where only the rapid rectilinear is possessed, for the two glasses or "elements" to be of different foci. For example, if one is of very long focus and the other medium, then medium and narrow angles are given when each is used alone, a wide angle being given when they are used together. It should be mentioned further that the rapidity of any lens depends entirely upon its intensity ratio or the proportion which the diameter of the largest stop that will give the desired

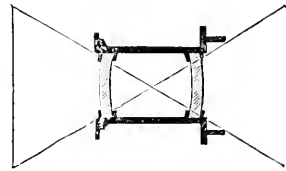

Fig. 47.—NARROW ANGLE LENS.

sharpness bears to its focal length. The larger this stop is, the more light will pass, and the quicker will be the lens. A common fallacy is to suppose that a whole-plate lens is necessarily quicker than a half- or quarter-plate. There is no advantage in using the larger lens provided the smaller one covers with desired sharpness at the same aperture, and the use of the larger lens would cause more reflections in the camera, with possible loss of brilliancy in the picture. When buying a photographic lens, have it upon approval when possible, and then the following points should be tested for. It is a convenience to at once obtain some rough idea of the focus, and this may be done by focussing any distant object, measuring the distance from back of lens to plate in a single lens, or from diaphragm to plate in a doublet. The proportionate value of the stops when not marked is given

approximately by dividing their diameter into the focal length. The fraction obtained is called the intensity ratio.

ASCERTAINING THE FOCUS OF A LENS.

Fuller particulars on determining the focus of a lens may be useful. If a number of parallel rays of light fall upon the surface of a double-convex lens, striking it at an angle, they will be refracted or bent towards the centre ray, and the point where these rays meet is the principal focal point. The greater the convexity or outward curvature of the lens, the more will these rays be bent and the nearer will this point be to the lens. The focal length is the distance from this point to the optical centre of the lens. The focus of a lens is the nearest point to the lens at which a sharp image can be obtained of a distant object. In the case of a single lens it is sufficient to focus an object at least 50 ft. away, and to measure with a foot-rule the distance from the ground surface of the focussing screen to the back surface of the lens. In the case of a doublet or compound lens, it may be ascertained in the same way, but it is then generally the "equivalent" and not the "back" focus which is required; or, in other words, the focus of a single lens which would give an image of the same size at the same distance from the object. This is found with fair accuracy by the following method:—On a wall stick two strips of white paper, the outer edges of which are exactly 2 ft. apart (or make other marks which can readily be seen on ground glass), and focus these sharply one-fourth the original size, so that on the ground glass they will be 6 in. apart. Then measure the exact distance from wall to screen. A weight attached to a piece of string, and held in the plane of the ground glass, will enable the exact distance to be measured along the floor. This distance has to be multiplied by the ratio or proportion of image to object, and the product divided by the ratio plus one squared. Therefore, supposing the distance from wall to ground glass is 50 in., the working will be 50×4 (the ratio) $\div (4 + 1 \text{ squared}) = 200 \div 25 = 8$ inches, the required focal length.

TEST FOR CHROMATIC ABERRATION.

Nearly all lenses sold for photography, unless exceedingly low in price, are achromatic; that is to say, their chemical focus and their visual focus occur at the same distance from the lens. If this is not so, negatives will always be out of focus, no matter how sharp the image appears on the screen, owing to the rays of light which act most upon the photographic plate coming to a focus nearer the lens than those which most affect the eye. Consequently, the chemical rays have widened out again at the visual focus and surround each point of light with a halo. For the tests about to be described, a series of vertical and horizontal parallel lines forming squares is required. A chess-board with its squares numbered clearly may be used. The camera should be used on the edge of a table, and not on a tripod. Care must be taken to keep the board, camera front, and screen top absolutely parallel. Swing the back to a considerable angle. Focus the board roughly with full aperture about one-fifth size, and accurately focus a certain square near the centre. The slide should now be very carefully inserted and a plate exposed and developed. If this square is equally sharp upon it, the lens is achromatic. If, on the other hand, another square is sharper, the exact correction may be at once estimated. In all these experiments the dark slide must of course be in correct register with the screen; this is easily tested for by placing a sheet of ground glass in the slide, the rough side of the glass being towards the lens, in the exact position occupied by the plate.

TESTING FOR COVERING POWER.

For testing for covering power and flatness of field, the back should be placed strictly vertical and the chess-board again photographed, this time one-fourth its size with full aperture of the lens. The lens should be shifted as far as possible to one side of the camera, and only about half its field used. This is explained by Fig. 48, the right-hand side of the board being focussed at the left of the plate. If the

camera front has not any side movement, the rising front should be shifted, the bottom row of squares being focussed along the top of the screen. The negative will show how far the definition extends, and this distance multiplied by two will give the circle in which the plate must be included. Say, for instance, it extends $2\frac{1}{2}$ in. at $f/8$; that would give a circle of 5 in., which would be only large enough for a quarter-plate. At $f/16$ it extends $3\frac{1}{2}$ in.; this would do for a half-plate. If possible, the lens should cover well, at full aperture, the plate to be used. It is a help if a similar photograph is at hand for comparison, taken with a lens of a known quality.

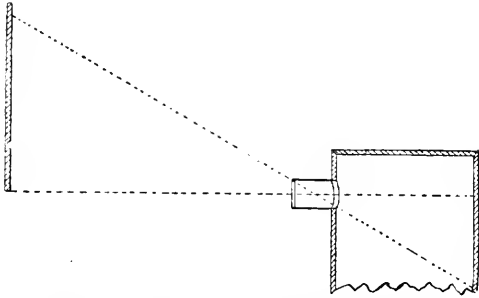

Fig. 48.—TESTING LENS FOR COVERING POWER.

TESTING FOR ASTIGMATISM.

In endeavouring to correct roundness of field, lenses are often caused to show astigmatism. To detect this, pin two narrow strips of white paper at right angles across the board. Focus sharply in the centre of the screen the centre of the cross thus formed (moving the camera until it is exactly central with it). Move the camera sideways till the centre of the cross falls near the margins; if both vertical and horizontal lines are sharp at once the lens is correct, but if when the one line is focussed the other is indistinct, as will probably be the case with any but first-class lenses, the lens shows astigmatism. The amount may be gauged by the amount of extension required between the two foci.

TESTING FOR FLARE SPOT.

Flare spot is a defect sometimes met with, and it may be detected by focussing

sharply in the centre of the screen the flame of a lamp or candle; if there appears a circle of light around the image, and if the circle remains in the same place regardless of the camera being moved round, the lens will show, on any negative taken under similar conditions, a round patch of fog in the centre. The lenses should be dusted before this test, and stops and tube should be carefully examined to see if they are thoroughly blackened. Flare spot may generally be remedied by a slight alteration in the position of the stop.

TESTING FOR SPHERICAL ABERRATION.

Spherical aberration is a defect shown by a general diffusion of focus, and in portraiture is to an extent desirable. Focus the chess-board sharply with a medium stop. Now stick to the front of the lens—in the centre—a circular piece of paper the same size as the stop; if any serious change in definition takes place, spherical aberration is shown, due to the rays transmitted through the margins of the lens coming to a different focus from the central ones. To estimate the degree of spherical aberration proceed as in the case of astigmatism. With such a lens it is sometimes advisable to focus with the working stop.

SCRATCHES, AIR BUBBLES, ETC.

Scratches, air bubbles, or discoloration of glass, may be detected by placing the lens upon a sheet of white paper. They scarcely ever affect practical working, but make the lens a very little slower—hardly recognisable in ordinary work. Many high quality lenses of Jena glass have air bubbles.

DETERMINING POSITION OF STOPS.

The practical method of determining the distance from the lens at which to place the stop is to cut a length of cardboard tubing, and in it fix the lens by springing in the tube a wire ring to form a shoulder for the lens to rest against, and then another ring to keep the lens squarely fixed in the tube. A slot must be cut along the tube at the bottom, and a card stop with a piece of wire attached placed in the

tube flat against the lens. Focus a square sheet of type and it will be found to be sharp only in the centre. Move the stop slowly down the tube away from the lens by means of the wire, and note that the definition spreads rapidly towards the margins, but as the definition spreads the square begins to assume the appearance of a barrel. The best position is that giving the maximum of covering power with the minimum of distortion, usually where the stop just illuminates the corners of the plate. As this position is not always possible, the following method may be sub-

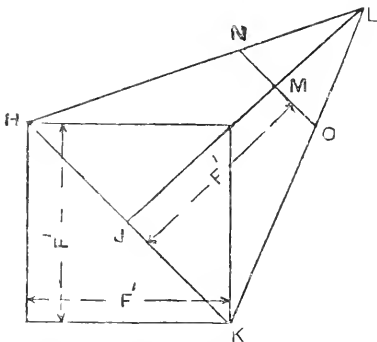

Fig. 49.—DETERMINING POSITION OF LENS STOP.

stituted. Draw a square each side of which is equal to the focus of the lens, as F' (Fig. 49), and a diagonal line $H K$, and from its centre erect a perpendicular $J M$ equal to the focus; at M draw a line $N O$ equal to the diameter of the lens. Now draw two lines from H and K through N and O until they meet at L . The distance from M to L is the distance required.

MAKING STOPS.

Lens stops may be cut from sheet brass with a fret-saw to fit the diaphragm opening, afterwards blackening with dead black solution, the composition of which is given on another page; or they may be cut from sheet ebonite.

PARTING CEMENTED LENSES.

Cemented lenses may be parted in the following way: Lay a piece of wood in the

bottom of a small saucepan and place the lens, which must have been removed from its cell, upon it. To do this it may be necessary to turn over the edge of the cell; but they are often screwed in with an inner rim. Warm water is then poured gently into the saucepan until the lens is covered. The saucepan then is heated gently and kept so until the lenses are found to slide easily apart. The old balsam may now be cleaned off with ether upon a silk handkerchief, but great care must be taken not to scratch the surfaces or injure the polish. Afterwards wash in

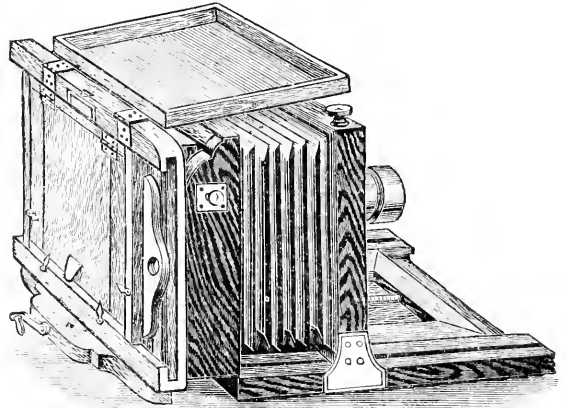

Fig. 50.—TYPICAL STUDIO CAMERA.

soap and water. Be careful to remember which surfaces were together. When the lenses have been finally polished up with a wash-leather, a drop of best Canada balsam, baked until it has become hard, and then made hot so as to be thin enough for use, is applied to the centre of the concave surface and the other pressed down upon it till it spreads evenly. Warm the lenses before doing this. Now bind the two together with string, winding round and round in all directions. Heat the lens gently until the balsam is thoroughly hard, which may be ascertained by testing that which has oozed out at the edges. Remove the string and clean the edges with ether, and it will be ready for re-insertion in the cell.

THE STUDIO CAMERA.

A camera for studio work requires an extra amount of strength and rigidity,

since it will require to stand a good deal of hard wear. It is therefore made of a different pattern from the field camera, in which, naturally, lightness and portability are chiefly considered. A typical studio camera is shown by Fig. 50. A studio camera may focus by a rack and pinion in the ordinary manner, or by an

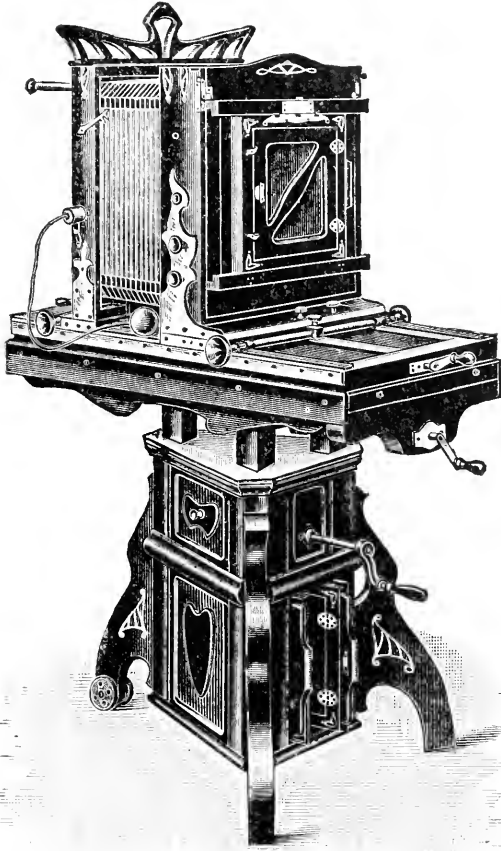

Fig. 51.—ORNATE STUDIO CAMERA AND STAND.

endless screw actuated by turning a handle at the back, the latter arrangement being the most accessible and convenient. The slides are single, and are filled by opening a hinged door at the back. They should be provided with a set of carriers for taking smaller sizes of plates if desired. It is convenient to have as long an extension as possible, the camera being then available for copying and similar purposes. It is

always advisable to purchase a good quality outfit, brass-bound for preference. A really good studio camera should last a lifetime even when in constant use. Fig. 51 is given as an example of a highly ornate studio camera and stand, intended for professional photographers who are particular about the artistic appearance of their apparatus, and regardless of expense.

MAKING A STUDIO CAMERA.

To make a studio camera to take 12-in. by 10-in. plates use mahogany $\frac{3}{8}$ in. thick. First construct the baseboard, Fig. 52, of

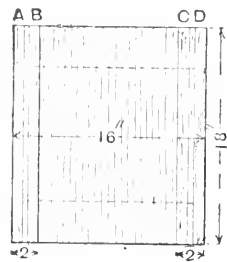

Fig. 52.—BASEBOARD.

the size shown in the illustration, by tonguing together. Then make two strips E and F (Fig. 53) 16 in. by $\frac{3}{4}$ in. by $\frac{1}{16}$ in., and glue and screw these in the spaces A and B (Fig. 52). They will then be $\frac{1}{2}$ in. apart, and extend 2 in. from the edges, and stand up $\frac{1}{16}$ in. A strip I $2\frac{1}{4}$ in. by 16 in. is next strongly attached, as in Fig. 53, with a $\frac{1}{4}$ in. slot for a clamping rod running from about 2 in. or 3 in. from each end. A similar slotted rail is then made to come over C and D (Fig. 52). Next form the ex-

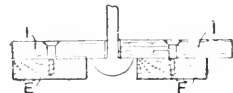

Fig. 53.—SECTION OF SLOTTED RAIL.

tension frame (Fig. 54) to run freely in the grooves of the baseboard rails. The focussing screw J may be purchased ready made; it is fitted by screwing down the bolt G to the baseboard, and the nut to the end of the extension frame at H. Construct the sliding frame (Fig. 55) by dovetailing four pieces each 16 in. by 3 in.

Inside this fit a frame κ $1\frac{3}{4}$ in. wide, flush with the front edges, and screw across two grooved pieces L for the rising front, 3 in. by 16 in. The rising front board may next be got out, with the two rebated rails for the sliding front: this is sufficiently explained by Fig. 56. The sliding front or lens board is shown in Fig. 57. Now make the back frame (Fig. 58), giving about $\frac{3}{8}$ in.

L , Fig. 55, and the back to the frame M , Fig. 58, and put under pressure till thoroughly dry. The fixed frame, shown in side view by Fig. 60, is prepared 16 in. by $3\frac{3}{4}$ in. The back frame is fitted with the pivots to the fixed frame at v , and the whole is then made up and screwed firmly to the back of the extension frame. Now make the reversing back (Fig. 61) by first

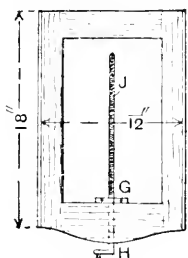

Fig. 54.—
EXTENSION FRAME.

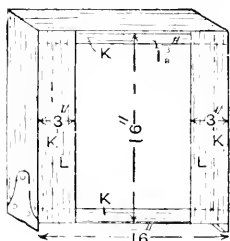

Fig. 55.—
SLIDING FRAME.

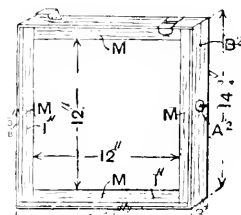

Fig. 58.

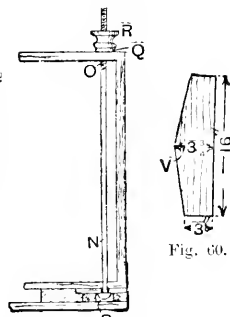

Fig. 59.



Fig. 60.

slope to the top and bottom to allow of swing. These four pieces, $14\frac{3}{4}$ in. by 3 in., are dovetailed together. Then sink the nuts for the thumb screws B^2 and the pivots A^2 . Inside the framework fit carefully a framework M exactly $\frac{3}{8}$ in. from the

Fig. 58.—BACK FRAME. Fig. 59.—FRAME AND CLAMPING RODS. Fig. 60.—SIDE VIEW OF FIXED FRAME.

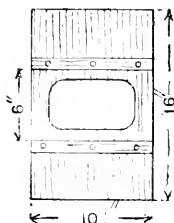

Fig. 56.—
RISING FRONT BOARD.



Fig. 57.—
SLIDING FRONT.

back edge, and 1 in. wide; cover it with velvet on the near side. It is an advantage to bevel the frame towards the centre to allow of central expansion of bellows when closed. Proceed by fitting the clamping-rod x (Fig. 59). These consist of a long screw and nut, but the thread o need only extend about 1 in. p is a circular plate to grip the side rail, q a washer, and r the thumbscrew or clamping nut. The bellows are made according to instructions to be found in another chapter, or they may be obtained ready made. Glue the front of the bellows to the framework

joining up a frame of four pieces, and across them glue and serew two strips s and t $1\frac{1}{8}$ in. by 14 in., with $\frac{1}{8}$ in. groove at u . A further strip (not illustrated) may be fitted across between the two at w to form a stop for the slide. This must all be done in $\frac{1}{16}$ -in. stuff to make the frame exactly $\frac{3}{8}$ in. thick when finished. The focussing

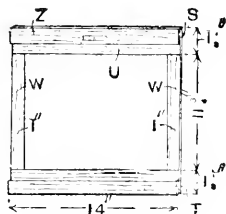

Fig. 61.—REVERSING
BACK.

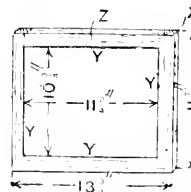

Fig. 62.—FOCUSING
SCREEN FRAME.

screen frame is formed as in Fig. 62. The tongue x engages with the groove u , and the $\frac{1}{16}$ -in. rebate y is for the focussing ground glass, which is held in by narrow strips of brass across the corners. Attach the screen frame to the reversing back by double hinges at z .

CAMERAS FOR COPYING.

The principal requirement in a camera intended for copying is a long extension.

easel to carry the print or drawing which is being copied as shown in Fig. 63, which will be more fully de-

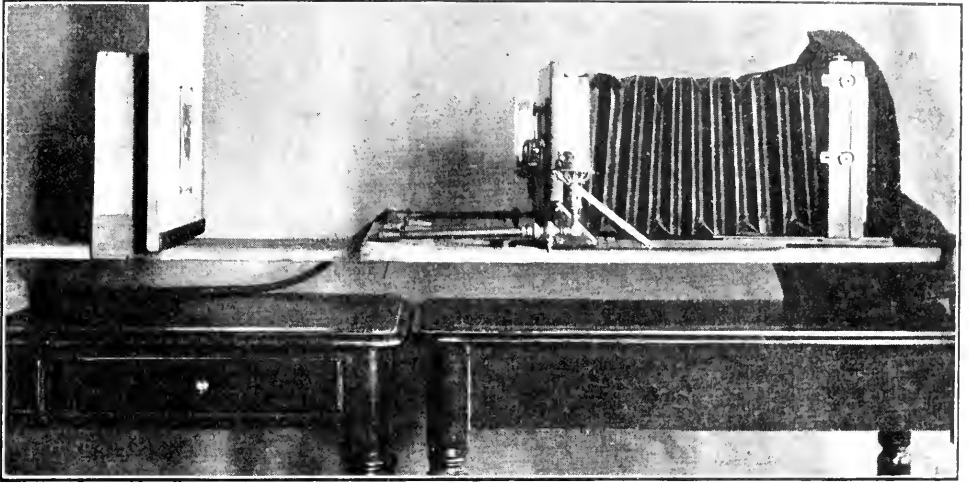

Fig. 63.—ARRANGEMENT FOR COPYING BY ARTIFICIAL LIGHT.

Any camera, therefore, may be used for the purpose which has a good length of bellows. Those, however, who have much of this work to do will find it more con-

venient to have a specially rigid camera, made with an extra long extension and of square bellows form. It is better to have the apparatus arranged on a fixed bench or table of suitable length, with a sliding



Fig. 64.—PORTABLE ENLARGING CAMERA OPEN.

venient to have a specially rigid camera, made with an extra long extension and of square bellows form. It is better to have the apparatus arranged on a fixed bench or table of suitable length, with a sliding

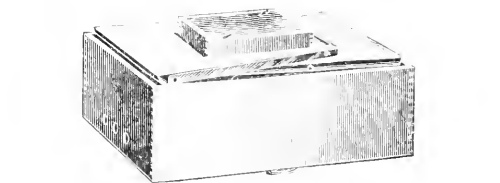

Fig. 65.—PORTABLE ENLARGING CAMERA CLOSED.

to the extent provided by the length of the wooden tube. But this plan is troublesome, especially with a heavy lens, which tends to weigh down the cone and cause distortion of straight lines, through the axis of the lens being out of its proper position relatively to the ground glass.

ENLARGING CAMERAS.

An enlarging camera is practically composed of three parts connected by an extra

length of bellows. The term is generally applied to apparatus intended for use with

adapted for copying, the length of bellows making them very suitable for the purpose. There are now many convenient patterns of portable enlarging cameras, folding into a very small compass. Some of these, of which Fig. 67

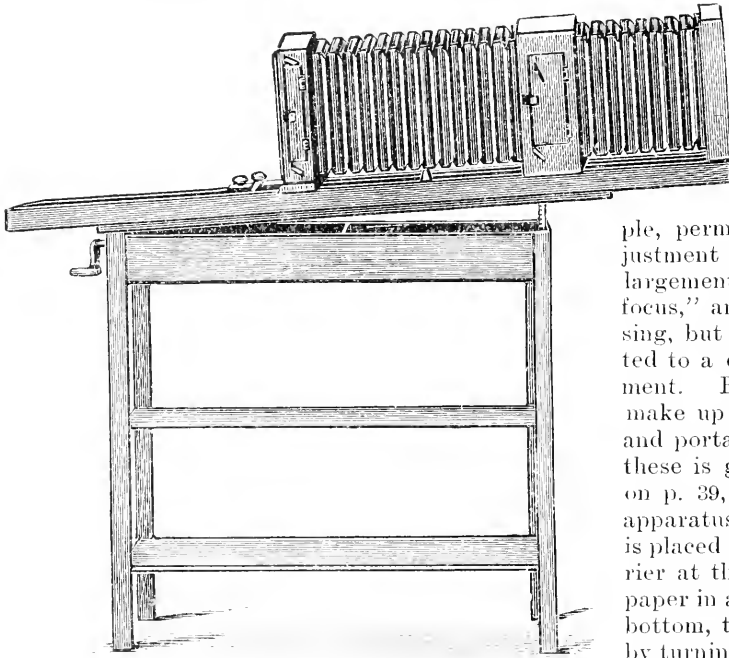

Fig. 66.—ENLARGING CAMERA AND STAND.

daylight; although occasionally a camera of this description may be adapted for use with artificial light. Fig. 66 shows a typical enlarging camera arranged on a suitable bench with tilting movement, in order that it may be pointed up in the direction of the light. A camera on this principle may be of any desired size, some of those used by professional workers being extremely large. At the end nearest the light is provided a frame having carriers of different sizes to take the negative. The lens is fitted in the central portion of the apparatus, and may be adjusted to any distance, while the plate or bromide paper is contained in a large dark-slide at the rear end. Some descriptions of enlarging cameras are also

permitted of focussing and adjustment for different sizes of enlargement. Others are of "fixed focus," and do not require focussing, but are in consequence limited to a definite area of enlargement. For this, however, they make up in greater compactness and portability. An example of these is given in Figs. 64 and 65 on p. 39, the latter showing the apparatus closed. The negative is placed in the small box-like carrier at the top, and the bromide paper in a removable frame at the bottom, the exposure being given by turning a handle outside which raises a hinged flap in front of the lens.

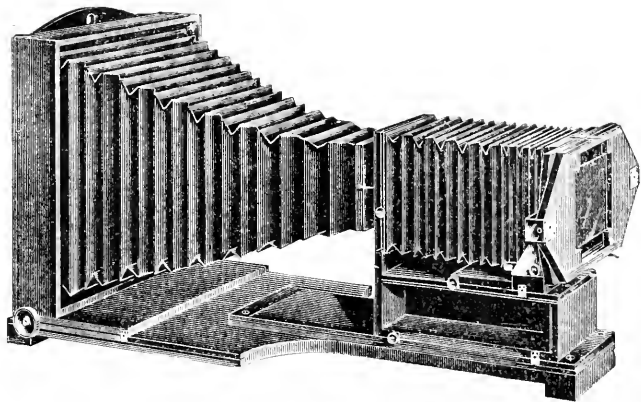

Fig. 67.—PORTABLE ENLARGING CAMERA.

MAKING AN ENLARGING CAMERA.

A cheap enlarging camera, which when not in use can be packed into a small space, may be made if the following in-

structions are carried out. If made to the dimensions given below it will allow of enlargements up to whole plate, and will pack into a space of $10\frac{1}{2}$ in. by 9 in. by $4\frac{1}{2}$ in. By modifying the dimensions given, the directions will apply to the construction of a camera of any ordinary size. Fig. 68 is a sketch of the camera with bellows and front removed. The base consists of three sections, A, B, and C. The back section A measures 9 in. by $4\frac{1}{2}$ in. To this is fixed the back of the camera J,

ARRANGEMENT OF BASE.

The middle part of the base B (Fig. 68) measures $8\frac{1}{2}$ in. by 8 in. Along the two longer edges of one face are glued two strips of wood about $\frac{1}{2}$ in. broad and just a shade thicker than the wood which is to be used for the part of the base marked C. Over these are glued strips (E E, Fig. 68) about 1 in. broad, between which and the base piece B slides the piece C. B is hinged to A either by two small hinges or by a strip of brown paper glued on; over the paper is a rather broader

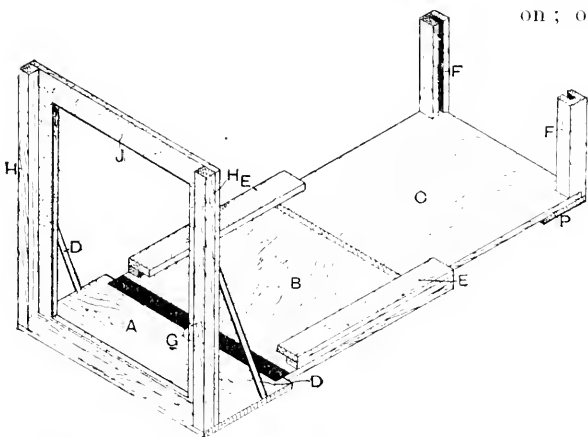

Fig. 68.—ENLARGING CAMERA WITH BELLOWS AND FRONT REMOVED.

which is made as follows. From a piece of good stout cardboard, or preferably millboard, measuring $10\frac{1}{2}$ in. by 9 in. is cut a square measuring a little more than $8\frac{1}{2}$ in. by $6\frac{1}{2}$ in., its sides being parallel to the edges of the cardboard, the remains of which form a frame all in one piece (see J, Fig. 69). Now cut three pieces of wood (H, Figs. 68 and 69) $\frac{1}{2}$ in. square, two $10\frac{1}{2}$ in. long and the third 8 in. long. These are glued to one face of the frame, which is then firmly fixed to the base-board A by gluing and by two small screws. The two parts must be fixed exactly at right angles to each other, and the back may be rendered firmer by means of supports, D D (Fig. 68). Before fixing the back in position it is advisable to fasten on the bellows, which will be described later. Fig. 69 is an elevation of the back, Fig. 70 showing the camera packed up.

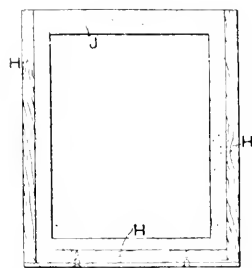

Fig. 69.—BACK OF CAMERA.

strip of black calico or linenette. The front part of the base C is 8 in. long and about 7 in. wide. It slides over B, and should be just wide enough to slide in with a little friction. Across the front end and underneath is fastened a piece P, 2 in. broad, cut with the grain of the wood at right angles to the grain in C, thus tending to prevent C from warping; it should project about $\frac{1}{2}$ in. in front of C. At the front end of the base are two upright pieces F F, firmly attached at right angles to it, and grooved on the inner faces to receive the camera front. Their height should be 4 in., but in breadth and thickness they may be made according to taste. Before attaching the bellows, the base board should be completely finished. A flat piece of brass G should be fixed to A by a small screw near the front edge, but left so as to turn. When the camera is to be used this is turned so as to project over B, which is thus kept in the same plane as A.

THE BELLOWS.

The bellows may be very well made from a piece of brown paper, over one side of which has been pasted a suitable-sized piece of black linnette, or any thin soft material. Before folding, the bellows should measure at the large end about $9\frac{3}{4}$ in. by $7\frac{3}{4}$ in., tapering to about 5 in. by 4 in. at the small end; they should be 25 in. to 27 in. long. The folds should be made a very little over $\frac{1}{2}$ in. deep, and it will then be found that the bellows will be a little over $8\frac{1}{2}$ in. by $6\frac{1}{2}$ in. at the back end, and 4 in. by 3 in. at the front end. If preferred, an oblong bellows can be used,

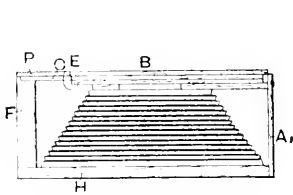

Fig. 70.—CAMERA CLOSED.

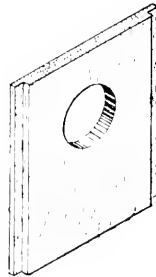

Fig. 71.—CAMERA FRONT.

but it will not pack so easily, and will require the camera front to be very little less than the back. Details of construction need not here be described, as full information, together with illustrations on bellows making, will be given in another chapter. The bellows, when made, are blacked inside.

THE CAMERA FRONT.

The front of the camera, which is made to slide between the uprights *F F*, should have a height of nearly 8 in. If made of wood, it is better to cut a rebate on each edge so as to leave a tongue down each side as shown in Fig. 71. The tongue should be a shade narrower than the grooves in which it slides. If made of cardboard, two pieces should be glued together, one wide enough to slide in the grooves, the other being as wide as the space between the uprights themselves. The hole in front for the lens should be

made so that its centre is directly opposite the centre of the opening of the back, that is about $5\frac{1}{2}$ in. above the base. The front is glued to the bellows so that the hole is exactly in the middle of the small end. The attachment is best made light-tight by previously screwing inside the end of the bellows a piece of cardboard which just fits, and has a hole in the centre a little larger than that in the front. When dry, this can be glued on the front. The bellows must then have its large end glued to the camera back. With the exception of one or two small details, this completes the camera itself.

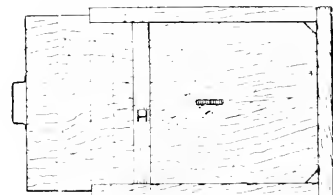
Fig. 72.—
DARK SLIDE.Fig. 73.—END OF
DARK SLIDE.

OPENING AND SHUTTING THE CAMERA.

To use the camera the base is folded down and the catch *c*, Fig. 68, turned to fix *B* in position. The front is now slid into position between the uprights and rough focussing done by sliding *c* in or out. It will probably be found that friction is sufficient to keep *c* fixed; but if not, a row of small holes can be made along *B*, and a hole through *c* so as to pass over these holes as *c* is moved. By pushing a small brass pin through the hole in *c* and the one beneath it the sliding piece can be fixed. Fine adjustment must be made with the ordinary camera, used in conjunction with the enlarging apparatus. When not in use, *c* is pushed back over *B* as far as it will go, the catch *c* turned, and *B* brought up so as to be parallel with the back. When this is the case the upright pieces *F F* will touch the back at their ends, where they can be held by small hooks fixed in the back and catching in eyes fixed near the upper ends of the upright pieces. The camera then is packed away to occupy little space.

THE DARK SLIDE.

To complete the apparatus, a focussing screen and some form of dark slide are required. Perhaps the simplest form of slide which can be used either for glass or paper is made as follows. Cut a piece of wood to form the back 10 in. by 8 in. so as just to fit the camera back. In the middle of this a short piece of watch-spring is fixed by one end. Glue down the sides, and along the bottom of this back (B, Fig. 73) strips of wood about $\frac{5}{8}$ in.

side pieces. In the middle of this must be fixed a small catch to hold the plate when in the slide. The catch must be sunk so as not to be above the level of the wood, and must be able to be turned. To keep the plate in position at the bottom, two wires about 1 in. long (pins with the heads broken off will do) are driven into the wood across the angles just below the grooves. The shutter s should be tongued so as to slide in the grooves. Should it be so desired, the shutter may be cut across and hinged by means of a light-tight hinge of cloth or other material at $\frac{3}{4}$ in. from the bottom. When enlarging on paper, this can be fastened to a piece of thin wood $8\frac{1}{2}$ in. by $6\frac{1}{2}$ in. by means of small pins, and then placed in the slide just as a glass plate. The slide is held in position by small pins in the camera back.

THE FOCUSSING SCREEN.

A focussing screen for the enlarging camera is made by fixing a piece of finely-ground glass in a frame of wood or cardboard, and fixing down the sides of the frame in front strips of wood of such a thickness that, when placed in the back of the camera, the ground surface of the glass occupies exactly the same position as the film of the plate (or the paper) when the dark slide is in position.

The frame may be hinged at the top to the camera back, so that it may be laid back over the camera when the dark slide is to be put into the required position.

STEREOSCOPIC CAMERAS.

The stereoscopic camera is provided with a pair of exactly similar lenses at a suitable distance apart, so that the two slightly different views necessary for making a stereoscopic slide may be obtained by one exposure. The lenses must be of precisely the same focal length and aperture, and if instantaneous work is to be done it is necessary to have a double-acting shutter, so that

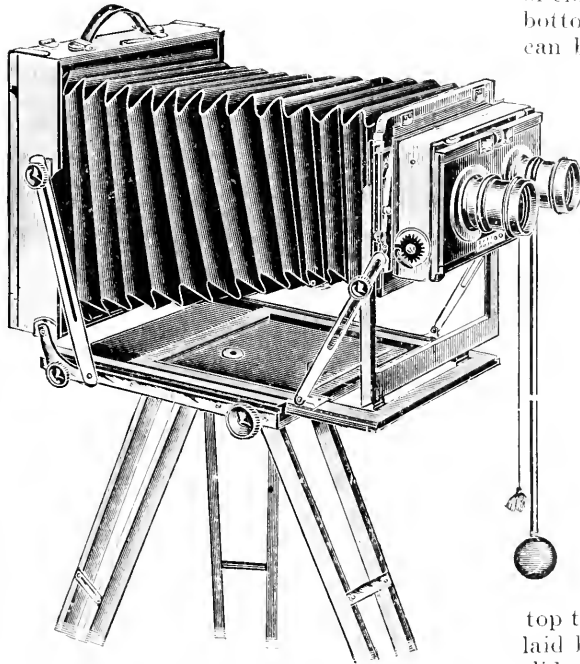

Fig. 74.—STEREOSCOPIC FIELD CAMERA, WITH ROLLER BLIND SHUTTER.

broad, and of such a thickness as together with the thickness of the back will make up $\frac{1}{2}$ in. These pieces are grooved down the inner faces near the front for the shutter (s, Fig. 73) to slide in. Figs. 72 and 73 are elevation and section respectively of the slide, and the latter figure will make this point clear. Across the top of the slide must be glued a strip of wood, H, $\frac{3}{8}$ in. broad and just thick enough to be flush with the back of the grooves in the

both may be exposed simultaneously. It is not proposed to deal here with the principles of stereoscopy; this will be fully explained, both as regards theory and practice, in a future chapter; it is only intended at present to explain the construc-

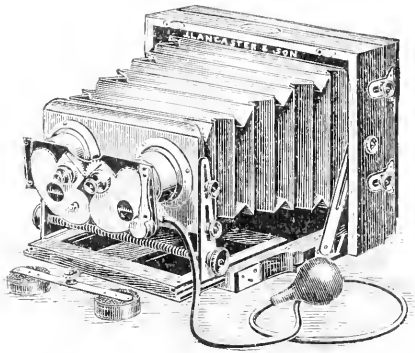

Fig. 75.—STEREOSCOPIC CAMERA, WITH SHUTTER BEFORE LENS.

one lens only by a slight alteration of the front. Another pattern designed primarily for stereoscopic work is shown by Fig. 75. This can be used with either shutter or caps, as desired. The peculiar form of double cap employed will be noticed in this illustration. A stereoscopic hand camera affords many opportunities of securing unique and interesting pictures. Fig. 76 shows a well-known model which is admirably adapted for the purpose, and, in addition, allows the front to be shifted so that one lens only need be used for obtaining panoramic views.

SLIDING FRONT FOR STEREOSCOPIC PHOTOGRAPHY.

Still objects, and ordinary landscapes in which there are no moving figures, can be taken with only one lens if a square bellows camera is fitted with a sliding front. Fig. 77 explains the construction of a slid-

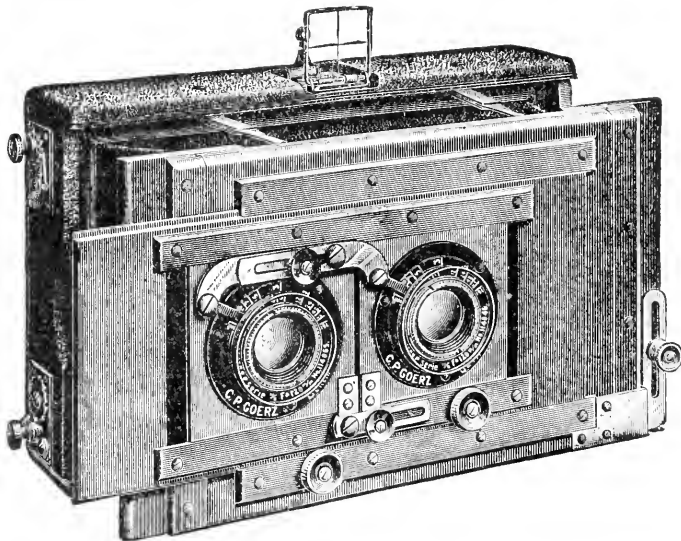

Fig. 76.—STEREOSCOPIC HAND CAMERA.

tion and peculiarities of the stereoscopic camera as compared with other apparatus. A very suitable pattern for field use is shown by Fig. 74. It is supplied with a roller-blind time and instantaneous shutter, working behind the lens, and may if desired be adapted for ordinary work with

ing front. The first exposure is made, and A is then pushed along until the mark B points to the mark C. The opening in the front board of the camera is shown by dotted lines. The distance between the two points may be varied according to the distance of the principal object. The farther

the principal object is from the camera the greater must be the separation between the two points. Sometimes it is possible to obtain stereoscopic photographs by

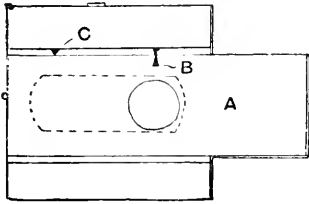

Fig. 77.—SLIDING CAMERA FRONT.

moving the object, as, for example, a vase of flowers, though this is rather difficult. In this case the camera and lens are stationary, and an ordinary quarter-plate camera can be used. Such a camera may

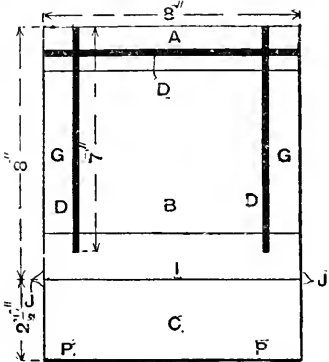

Fig. 78.—BASEBOARD FOR STEREOSCOPIC CAMERA.

also be used if it is fitted with a board as wide as the base from back to front and about double the length of the original base. Two parallel slots are made in this extra baseboard, and thumbscrews pass through these into the original baseboard. The camera may thus be slid from one position to the other and clamped.

MAKING A STEREOSCOPIC CAMERA.

The camera next to be described may be used as a hand or stand camera for taking ordinary half-plate photographs or for stereoscopic work, for the latter of which purposes it is particularly suited. Either one or two lenses may be employed, but

except under favourable circumstances of light and subject one lens alone is not of much practical use. Mahogany $\frac{3}{8}$ in. thick will be suitable for the camera body.

THE BASEBOARD AND EXTENSION.

Make the baseboard (Fig. 78) by joining up three pieces, A, B, and C, crossing the grain, and work out the grooves D. These are for the pinion and racks. Next join up the extension frame (Fig. 79), which consists of two pieces $5\frac{3}{4}$ in. by $1\frac{1}{8}$ in., one piece E $7\frac{1}{8}$ in. by $1\frac{1}{4}$ in., and one F $7\frac{1}{8}$ in. by $3\frac{1}{8}$ in., tongued together. The two rails

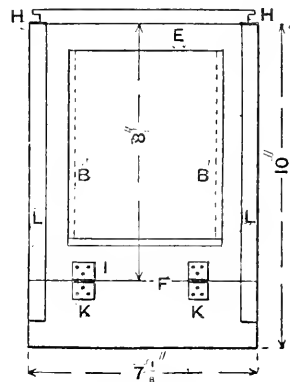

Fig. 79.—EXTENSION FRAME OF STEREOSCOPIC CAMERA.

are of rectangular section ($\frac{1}{4}$ in. by $\frac{1}{2}$ in.), with a rebate on one edge. Screw and glue them on, running the length of the base at G (Fig. 77), with the rebate inwards to engage with the tongue H (Fig. 79) of the extension frame. Fit the parts together and cut across the line at I (Figs. 78 and 79). Attach rule hinges at J (Figs. 78 and 85) for the base, and flat hinges at K (Fig. 79) to the extension frame. The sliding body (Fig. 80) is a mere frame 8 in. square, but through it pass the clamping rods Z, close to frame, which biting against L (Fig. 79) at X (Fig. 80) hold the frame and its attachments at any distance from the front.

THE FRONTBOARD FRAME.

With stuff $\frac{3}{8}$ in. thick make a frame M (Fig. 81) 8 in. square, with a centre opening

5½ in. square, and to it attach the front end of the bellows. This bellows, which must be square, may be purchased or made by following the directions given in another chapter. The frame is fixed at p (Fig. 78),

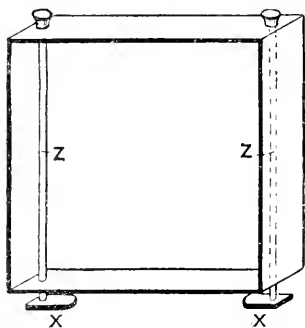

Fig. 80.—SLIDING BODY OF STEREOSCOPIC CAMERA.

Fig. 80, except that it contains an inner frame, which must be flush with the side nearer the lens, but ⅓ in. back from the other side; to the former side is glued the back of the bellows, and the side which is recessed is covered with black velvet. Screw two angle plates at s, and attach

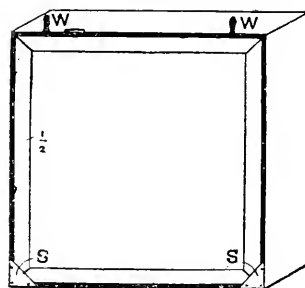

Fig. 82.—BACK FRAME.

and built up to the required height with a strip of wood. It is fastened by means of screws put through from the under side of the baseboard, and by corner pieces as shown in Fig. 85. At each side of m (Fig. 81) are fixed rails x, 8½ in. long, to take the rising front r, and across this are run two rails for the lens board. A brass plate q, 2½ in. long, and a screw fitting a nut in

the whole to the sliding body by means of four slotted plates t (Fig. 85) 2¼ in. long. Thumb-screws u through the slots allow the back to be clamped in any position. This provides the swing-back movement.

THE REVERSING-BACK AND FOCUSING SCREEN.

Now make another frame (Fig. 83) to fit the recess, with an opening 6¾ in. by

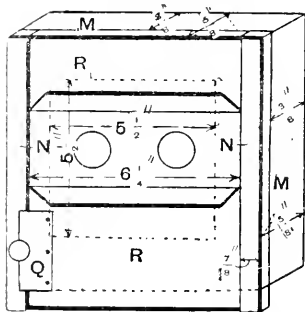

Fig. 81.—FRONTBOARD FRAME.

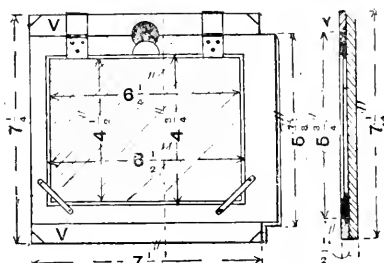

Fig. 83.

Fig. 84.

Fig. 83.—REVERSING FRAME. Fig. 84.—REVERSING FRAME EDGE.

x, which may be made to bite against q when screwed down, and which will hold it at different elevations, provide the rising front adjustment.

THE BACK FRAME AND SWING-BACK.

The back frame (Fig. 82), 8 in. square, may then be joined up, and is similar to

4½ in., and across it at v screw rails, sections of which are shown in Fig. 81. The focussing frame scarcely needs description; it fits between the rails v (Fig. 83), and carries a sheet of ground glass 6½ in. by 4¾ in. rough side inwards. Small turn-buttons at w (Fig. 82) serve to hold in position the reversing frame. Brass

clamps as in Fig. 85 should be attached to the edge of the baseboard, and screws *z z* to take the clamps. Remove the extension frame and screw on the racks *B* (Fig. 79), and fix in a pinion, not shown in the illustration, of the usual shape, having a brass milled head.

THE DIVISION OR PARTITION.

For the collapsible division, which next must be fitted, a strip of black twill must be cut 6 in. by 18 in.; run a hem along either side of the longer edges, and through this thread some flat elastic. Pleat the twill, and stitch it to the elastic at distances of about $\frac{1}{4}$ in. The elastic band must be not more than the focus of the lens, say

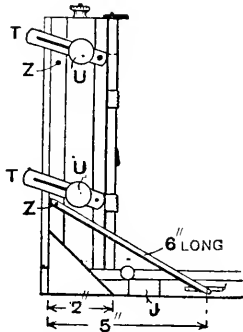

Fig. 85.—STEREOSCOPIC CAMERA WITH FRAMES CLOSED.

8 in., in length. A loop is left at each end for attachment to the camera front and to the back bellows frame, and the division accommodates itself to any extension of the camera. When the camera is required for ordinary work the division is easily removed.

WET-PLATE AND FERROTYPE CAMERAS.

Specially made cameras for wet-plate work are now seldom seen. The old form consisted simply of two boxes, one sliding in the other, and a somewhat primitive dark-slide, inserted through an opening or slit in the top of the camera. Any ordinary outfit may be used by those who desire to undertake wet-plate work, the only exception being that a slightly differ-

ent form of slide is required, having a shallow trough at the bottom to catch the drippings of the plates, and silver wires to support them. It is essential that the slides should be of the single or studio description; the book-form slide cannot be adapted for the purpose. Suitable apparatus can, however, be obtained from firms who make a speciality of requisites for wet-plate and ferrotype work.

AUTOMATIC FERROTYPE CAMERAS.

Automatic cameras for the ferrotype process are now obtainable, in which the development and fixing of the plates take place in a mechanically actuated arrangement. These are intended for use with

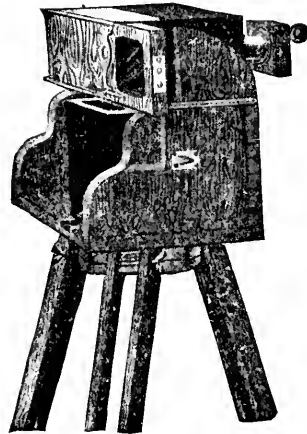

Fig. 86.—QUTA AUTOMATIC FERROTYPE CAMERA.

dry ferrotype plates, or, as they are sometimes called, American dry-plates. Among cameras of this description, which are much in favour with itinerant photographers, may be mentioned the "Takuquick" and the "Quta," the latter being illustrated by Fig. 86.

CAMERA FOR FERROTYPE PHOTOGRAPHY.

Beyond a few minor details there is no reason why the ordinary camera should not be used for ferrotype photography. An ordinary half- or quarter-plate camera answers very well, though it may be an advantage to have a repeating back and a studio

slide, with a groove in the bottom for drippings, and wires for plate to rest on, or it will be necessary to give the other slide a coating inside of paraffin wax. Those who consistently practise ferrotypy are generally provided with an old wet-plate box camera and a French portrait-lens. As

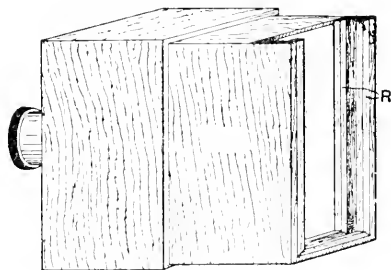

Fig. 87.—FERROTYPE CAMERA.

ferrotypes are slower than gelatine plates, a portrait-lens is often a necessity, whilst the box camera can be freed from dust more readily. A suitable box camera may consist simply of two boxes fitting one in the other (see Fig. 87). The outer box

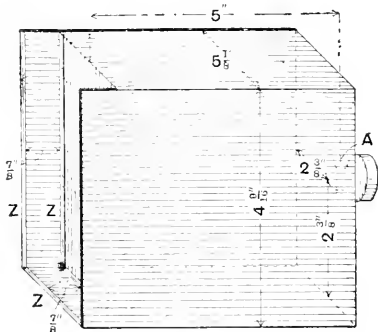

Fig. 88.—BODY OF FERROTYPE CAMERA.

has in the top a slot an inch or two long, for a thumbscrew to clamp together the inner and outer boxes. Rails R, at back, take the focussing screen and slide, and the fine focussing is done with the rack and pinion on lens. As ferrotypy is a positive exposed. Where only two or so pictures are required, this may be done with the repeating-back, but a battery of lenses for taking a number of pictures in one exposure is the general plan.

MAKING A FERROTYPE CAMERA.

The following instructions explain how to make a cheap camera for taking portraits on ferrotype plates $3\frac{1}{4}$ in. by $2\frac{3}{8}$ in. A portrait lens of 5-in. focus should be procured and the camera made to suit it. The

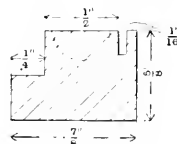

Fig. 89.—SECTION OF DARK-SLIDE FRAMING.

lens will probably be fitted with an outer jacket (which screws into a flange for attaching to camera front), in which the lens is moved backwards and forwards by a rack and pinion for focussing (A, Fig. 88). To make the dark slide, groove and rebate three pieces of the form and size shown in Figs. 89 and 90, and mitre the ends. In one piece gouge out a part of the middle, shown by the dotted semicircle in Fig. 89; stop about $\frac{1}{8}$ in. from each end. This forms

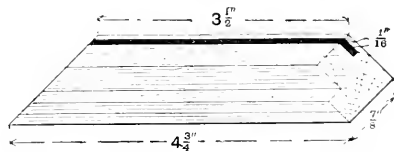
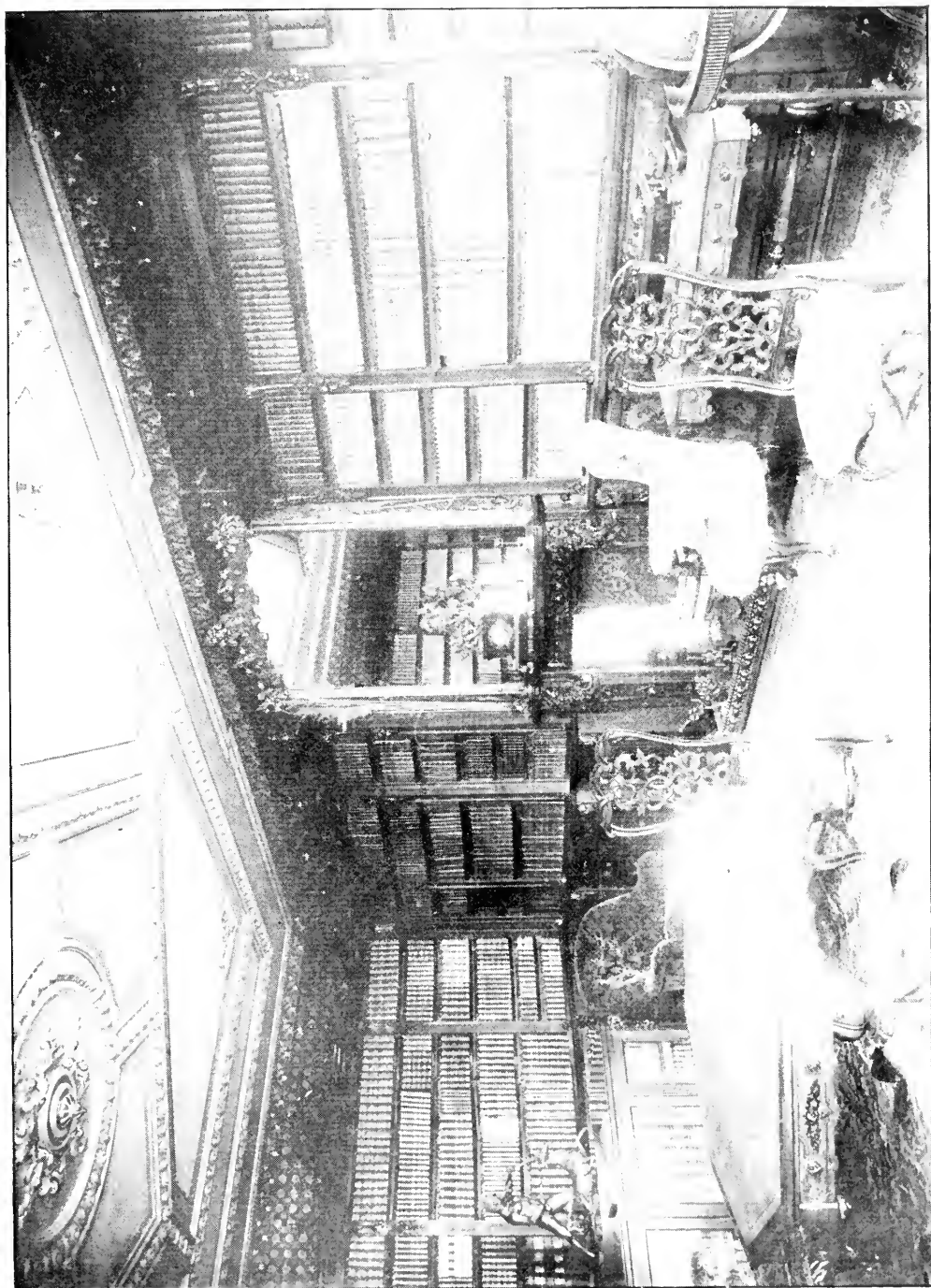

Fig. 90.—PIECE OF DARK-SLIDE FRAMING.

a trough to hold the drippings from the plates, and it may be covered with metal. In the top of the two slides at x (Fig. 91) is a wide slot that receives a tongue B in the top rail. This top rail is shown by Fig. 92. Place the two mitred corners together in the bench, and, having made a saw-cut across, insert and glue in a strip of veneer. Fix the top bar with the front tongue cut away as in dotted lines in Fig. 93, and recessed at v to take a narrow strip of velvet. Now cut the pieces A B C D (Fig. 91), and glue and tongue together A B C; attach B to the rest with a strip of opaque cloth, making a board $4\frac{1}{2}$ in. by $3\frac{3}{4}$ in. having an $\frac{1}{8}$ -in. rebate on three sides. Fit into the grooves of the framework, and



SPECIMEN OF PHOTOGRAPHING INTERIORS.

glue on stops at the back to prevent complete withdrawal. A strip s is glued to the sides to form a shoulder which shuts down on the top of the camera and helps to exclude light. Fix silver wires, bent as in Fig. 94, $2\frac{3}{4}$ in. apart, two in each side, to take the plate horizontally and vertically. These project into the slide $\frac{1}{8}$ in. Glue in

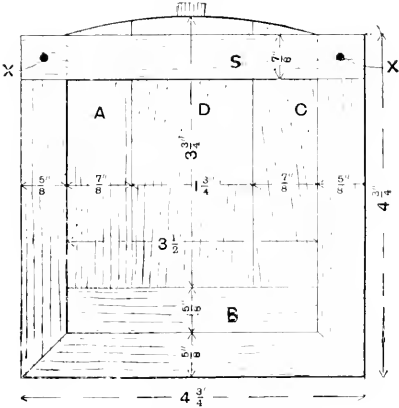

Fig. 91.—DARKSLIDE AND RAILS.

the guiding strips for the slides z z (Fig. 88). Fix in the slide against the wires a piece of ground glass, rough side inward; insert the slide in the camera and focus. Remove the slide gently and insert a framework made by joining four pieces $1\frac{3}{4}$ in. by

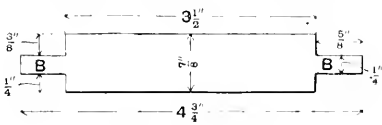

Fig. 92.—TOP RAIL.

$\frac{3}{4}$ in. by $\frac{3}{8}$ in.; adjust the ground glass so that it will register correctly with the slide, and fix. Cut a board $4\frac{1}{4}$ in. by $4\frac{1}{4}$ in., and attach to its inner side a flat spring to hold the plate in position. Hinge this board at the top and put a button at the bottom to fasten it, and the apparatus is complete.

AUTOMATIC FERROTYPE CAMERA.

The so-called automatic camera for dry ferrotype plates consists practically of a magazine camera sliding upon rails, under

the centre of which is a rubber-lined tank used for developing, and connected with it are three rubber balls, each containing one of the three necessary solutions capable of being forced up into the tank in turn by pressing the ball, whilst turning a tap prevents the liquid from running back. The whole is supported upon a tripod having a sort of cupboard at top for bottles, etc.

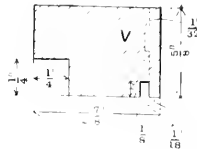

Fig. 93.



Fig. 94.

Fig. 93.—SECTION OF TOP RAIL. Fig. 94.—PLATE WIRES.

The construction of the camera enabling the plates to fall one at a time is shown in Fig. 95: A is the lens with rack and pinion B, to which may be fitted a simple pull-up-and-down shutter; c is the focussing screen, guided forward into position by the nut D; E E are side rails, guiding the fall of the plate and holding it in an upright position; F and G are open cham-

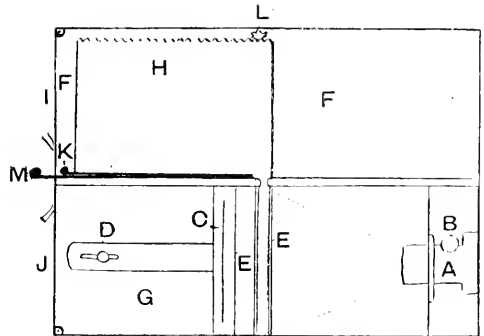

Fig. 95.—AUTOMATIC FERROTYPE CAMERA.

bers, the former containing the magazine H for holding the plates: I and J are doors. Insert the magazine H through the door I, and bolt the lid or bottom to the sides at K. Open the door J and push the screen c into place, focus with lens, pull back the screen, close the door, and then turn the thumbscrew, revolving the pinion L, which, moving the magazine forward, brings the

first plate over the opening in the floor of the chamber. Now pull out the catch *u*, and the plate will fall into position between the rails *E E* in the chamber below, for in winding the magazine forward the lid will have been left bolted behind, and nothing remains to stop the free passage of the plate. Return the catch, and the camera

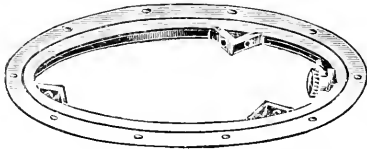

Fig. 96.—TURNTABLE FOR CAMERA STAND.

is ready for exposure. The exposed plate falls into the developing box below by means of two similar catches, one in the camera and another over the tank. This developing-box can be used with ordinary as well as ferrotype plates; by taking it off, the camera may be used as a hand



Fig. 97.—FEATHERWEIGHT STAND.

camera. There are many more elaborate arrangements on this principle.

CAMERA STANDS.

Absence of vibration being an indispensable factor for successful photographic work, due attention should be given to securing a strong and serviceable support

for the camera. There are various descriptions of stands, each adapted for use with some particular kind of camera. For the ordinary field camera the kind shown by Fig. 98 is generally employed. It may be either two-fold, three-fold, or four-fold; the two-fold form is probably the strongest and most rigid, while the others are more compact and portable. A tripod-top of wood or metal is also required, unless the camera is fitted with a turntable (see Fig. 96), in which case the legs would be attached to that. The stand should be free

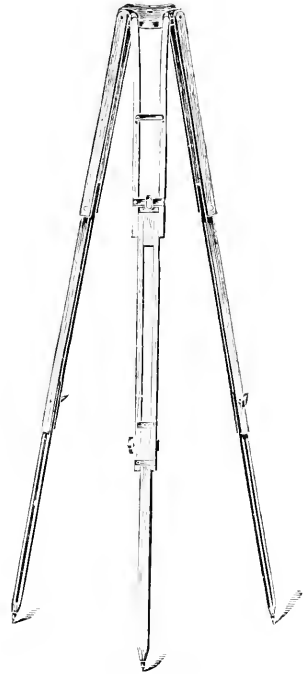

Fig. 98.—THREE-FOLD TRIPOD STAND.

from shakiness, and capable of bearing the weight of the camera; a stand which would be suitable for a quarter-plate outfit would be quite useless for a heavy whole-plate camera. Whatever the size, the legs should be provided with points or spikes to prevent slipping. A very light description of tripod stand, suitable for cyclists and tourists, is shown by Fig. 97. This pattern is generally given the expressive title of "Featherweight."

STUDIO STANDS.

A stand of quite a different make is required for studio use. It has to be moved by pushing along the floor of the studio, so that three shifting legs would be inconvenient. The framework of the stand is therefore solid, and runs on castors, while the necessary adjustment for height is provided by a rack and pinion movement or

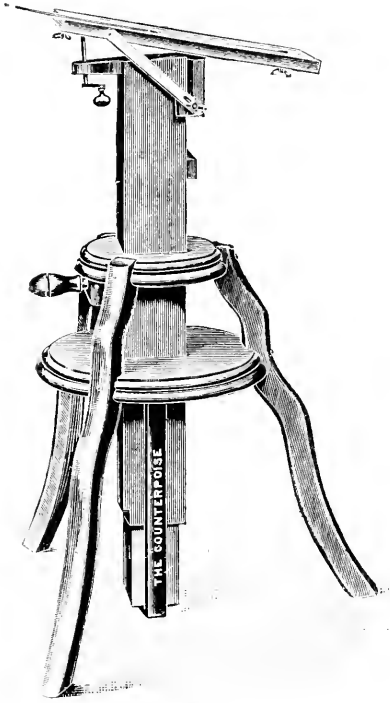

Fig. 99.—COUNTERPOISE STUDIO STAND.

a screw. Another pattern of stand is fitted with a weight which balances the rising and falling portion, the equilibrium being maintained by means of pulleys. A recent improvement in studio stands, whereby in addition the tilting arrangement at the top is especially well balanced, is shown by Fig. 99, and is known as the "Counterpoise."

MAKING A STUDIO CAMERA STAND.

The ordinary studio camera stand (Fig. 100) combines to some extent the port-

ability of the tripod with the solidity and firmness of the table stand, being supported on three stout legs mounted on castors, for moving readily. The double tilting stop, *c*, measures 15 in. by 11 in., the wood being $\frac{3}{4}$ in. thick. The hinged part of the double top has a ledge *d*, to prevent the camera slipping off when tilted. The lower part is supported on a bracket *g*, whose shape is shown by the enlarged view (Fig. 101). The upper circular platform *A*, and lower circular platform *B*, are shown separately (Figs. 102 and 103). In Fig. 100, *e*

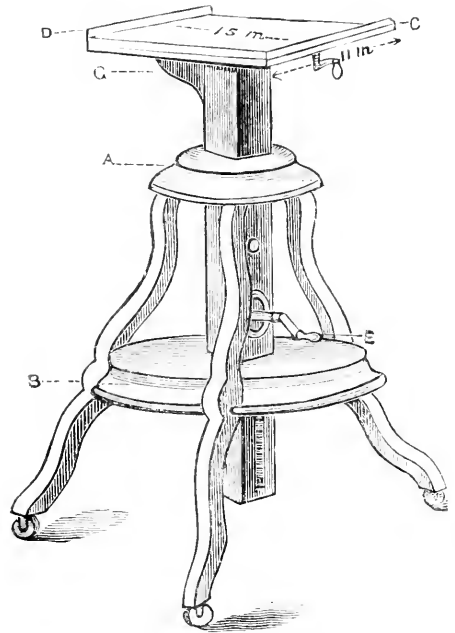

Fig. 100.—STUDIO CAMERA STAND.

is the handle by which the pillar on which the top rests is raised or lowered. Fig. 101 shows the double top, hinged in front, and raised or lowered by a wooden hand-screw or a winch and screw. The iron screw is 5 in. long, and say $\frac{1}{2}$ in. in diameter; each half of the top should be clamped to prevent warping.

LEGS OF CAMERA STAND.

For the legs of the camera stand cut out three pieces of wood, $2\frac{1}{2}$ in. by 2 in., as in Fig. 105: they may be straight if desired,

but the curves improve their appearance. The length from above the castors to the top is 3 ft. 4 in., and the height of the first circular platform from the ground is 18 in. The upper circular platform (Fig. 102) is of 2 in. wood, and is 8 in. in diameter.

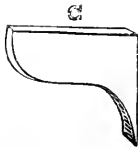

Fig. 101.—BRACKET FOR TOP OF STAND.



Fig. 106.—PILLAR WITH RACK.

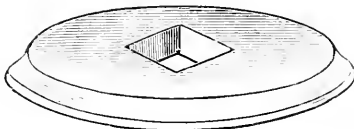

Fig. 102.—UPPER PLATFORM

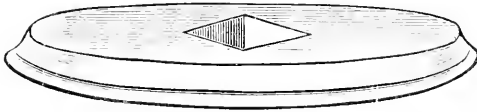

Fig. 103.—LOWER PLATFORM.

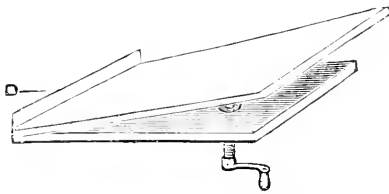

Fig. 104.—HINGED TOP OF STAND.



Fig. 105.—LEG OF CAMERA STAND.

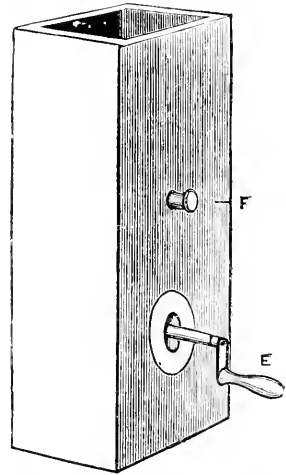

Fig. 107.—CASING FOR PILLAR.

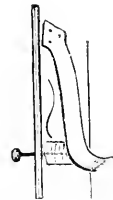

Fig. 108.—SPRING CATCH.

The lower one (Fig. 103) is of 2½ in. wood, and 15 in. in diameter; both of them are nicely shaped at the edges, and have square holes cut through the centre, just large enough to allow easy passage of a solid pillar of wood (Fig. 106), 2½ in. square and 3 ft. long; the lower part of the tilting top is screwed firmly to this pillar, which is let in about ¼ in.

THE WINCH AND RACKWORK.

One side of the pillar is provided with a strong iron rack about 20 in. long as shown in Fig. 106, and this when it is fixed in place engages with cog wheels attached to the winch handle, E, on the outer case

(Fig. 107) for the purpose of raising or lowering the table. In order to prevent movement by the weight of the apparatus after the table has been raised to the required height, a strong wooden hand-screw or spring catch (Fig. 108) is fixed on the inside of the thin casing, which, engaging with the rack, prevents any downward movement. By merely pulling the knob F the

rack is set at liberty, and may be lowered by the winch. The casing is made of $\frac{3}{4}$ in. wood, neatly joined, and extending between the upper and lower platforms, increasing the firmness and rigidity of the stand, and of just sufficient size internally to permit of the pillar moving easily through it, not forgetting to allow sufficient space for the cog wheels and winding arrangements. As

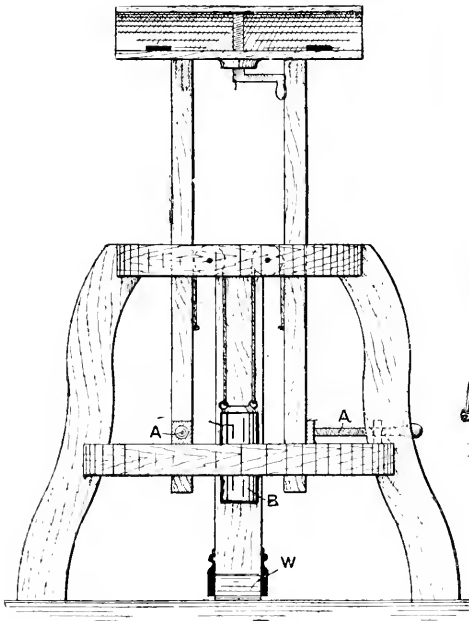

Fig. 109.—STUDIO STAND WITH WEIGHT AND PULLEYS.

this entirely depends on the size of the castings, it cannot be definitely stated; three of the sides can, at any rate, be flush with the square holes in the platforms. A small bracket, Fig. 101, attached to the pillar under the table is an advantage, as there is considerable strain on this part when using heavy apparatus. With the exception of the pillar and casing, all sharp edges should be taken off the work. The whole should be well polished, and the castors attached. The stand then is complete.

THE PULLEY AND WEIGHT

The winch screw and rack should be of the very best quality; otherwise they are liable to cause considerable annoyance. The strain upon them when carrying a large camera is very great—in fact, so much trouble has been experienced with them that one well-known photographer has adopted instead the principle shown in

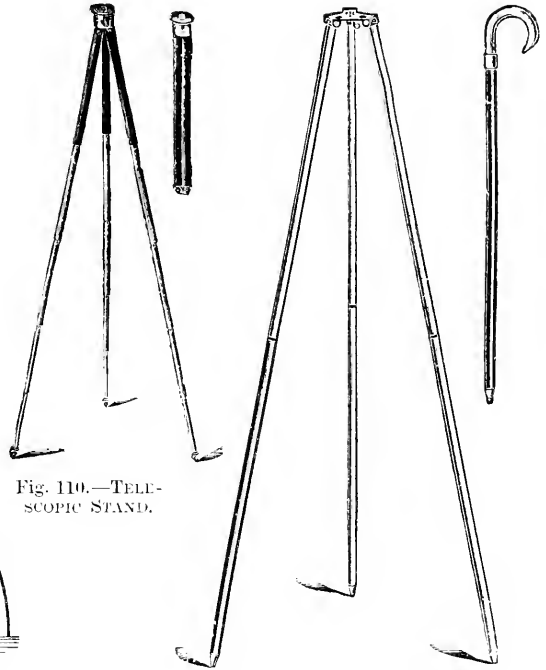

Fig. 110.—TELESCOPIC STAND.

Fig. 111.—WALKING STICK STAND.

Fig. 109. The method there illustrated has its drawbacks, and increases the weight of the apparatus; but it certainly possesses many advantages. To move the camera, loosen the screws A A, and it may be immediately placed at the desired level, higher or lower, without the least effort, as the weight B exactly balances the camera. Except when moving, the screws must be kept tightened, particularly when removing the camera from the stand. The essential thing is to have the camera run easily, and this is best done with one broad

wheel *w* in the front leg, in which case two handles should be fitted at the back by which to lift it. This arrangement will be found of the greatest assistance when working upon linoleum-covered or polished floors.

TELESCOPIC STANDS.

For cameras of small size, and for hand-cameras, a telescopic stand is very con-

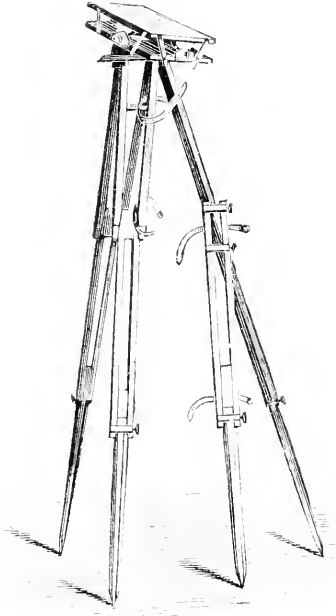

Fig 112.—STAND FOR ARCHITECTURAL WORK.

venient. These may be obtained in brass, steel, or aluminium, and consist of a number of sliding tubes moving inside each other. Fig. 110 shows such a stand extended and closed. They are extremely compact and portable, but the narrow top is not conducive to rigidity. Except for rather heavy cameras (for which they are not intended) or in a high wind, this objection is seldom of much consequence. An occasional wiping with a soft cloth slightly moistened with vaseline will prevent the joints from rusting or sticking, which they are somewhat liable to do unless constantly in use. A handy variety which may be used as a walking-stick is shown by Fig. 111.

STANDS FOR ARCHITECTURAL AND MONUMENTAL WORK.

A stand specially designed for architectural work, where it may be desired to use the camera at an elevation, is shown by Fig. 112. It will be noticed that it is specially adapted for a large, heavy camera, and that particular attention has been paid to the arrangement for tilting the apparatus. It is also well suited for monumental work. For the copying of inscriptions, brasses, etc., on the floor or pavement, a tilting board, as shown by

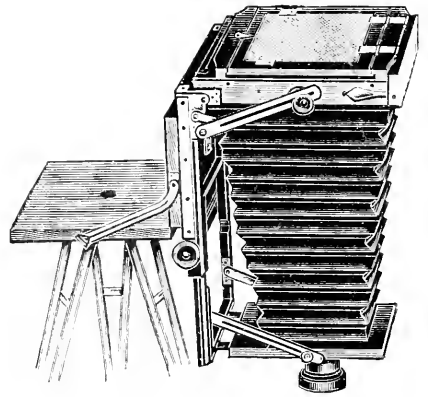

Fig. 113.—TILTING BOARD.

Fig. 113, is almost indispensable; or a mirror may be used at an angle of 45° to the lens.

CAMERA SHUTTERS.

The old method of exposing was by means of a cap, but an automatic shutter is now generally preferred; this is actuated by a pneumatic bulb or other means, and is capable of being set to give any desired exposure. The simplest form of shutter is that in which a wooden slide with a perforation of suitable size is allowed to drop in front of the lens, the exposure being given by the passing of the perforated aperture. This is known as the drop shutter. It does not give very rapid exposures, but the speed may be accelerated by the use of an indiarubber band. The chief objections against this form of shutter are the difficulty of adjusting the speed and the risk

of jarring the camera. Another kind of shutter, which operates by a sort of seesaw motion, is shown by Fig. 115; this is fixed on the front of the lens. The roller-blind shutter gives the exposure by the

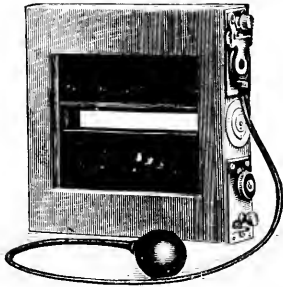

Fig. 114.—FOCAL PLANE SHUTTER

passage of an opening in a spring blind which may be set to pass at any given speed. This is controlled by the number of turns given to the spring of the roller, and the mechanism is released by pressing an indiarubber bulb at the end of a length of tubing. These shutters may be obtained to work either in front of or behind

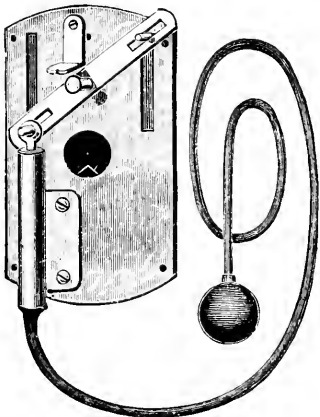

Fig. 115.—SEESAW SHUTTER.

the lens, while a third description, known as the "Focal Plane," works just in front of the plate. The advantage of the latter is that more light is allowed to reach the plate, and the exposure may consequently be shorter. These may now be obtained with an adjustable slit which gives a greater range of speed (see Figs. 114 and 116).

THE FLAP SHUTTER.

This description of shutter, as its name implies, depends in principle on the movement of a hinged flap in front of the lens, rapidity of movement being ensured by the use of an indiarubber band. It is simple

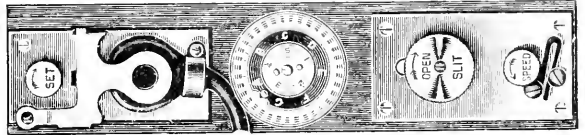

Fig. 116.—FOCAL PLANE SHUTTER (SIDE VIEW).

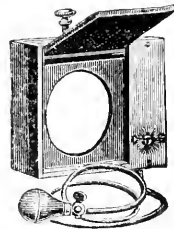

Fig. 117.—FLAP SHUTTER WITH PNEUMATIC ACTION.

in construction and effective in operation, but does not give very rapid exposures. The making of these will be fully explained later, so further particulars need not now

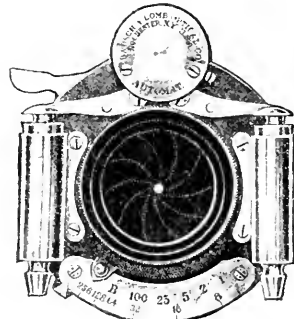

Fig. 118.—A TYPICAL EVERSET AUTOMATIC SHUTTER.

be given. A more elaborate application of the flap principle with pneumatic action, suitable for studio work, is shown by Fig. 117.

THE EVERSET SHUTTER.

Most of the shutters previously mentioned require to be set, or the mechanism

adjusted, before being ready for use. There is, however, a kind of shutter which is always ready for use, known as the "ever-set." There are a large number of makes, some comparatively simple in arrangement, others greatly complicated and ingenious. Fig. 116 is a typical example of a high-class modern automatic shutter, which is always ready for action and adjustable to almost any desired speed. It is possible, of course, to over-estimate the value of having the shutter ever set. After all, it is only a slight additional convenience. There are many

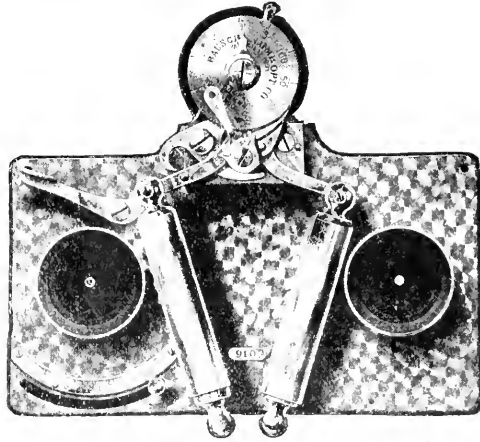

Fig. 119.—SPECIAL SHUTTER FOR STEREOSCOPIC WORK.

admirable designs of shutters requiring preliminary setting which are, nevertheless, in every way satisfactory.

STEREOSCOPIC SHUTTERS.

As explained when dealing with stereoscopic cameras, the shutters for this apparatus must be double, and simultaneous in action. As this simply means, in most cases, the duplication of the mechanism, further explanation is unnecessary. A double roller-blind shutter is shown on the camera front in Fig. 75, p. 41, while in Fig. 76 another pattern of double shutter is illustrated in position. A special shutter for stereoscopic work, of the Bausch and Lomb pattern, is shown by Fig. 119.

STUDIO SHUTTERS.

Any form of shutter may be used for studio work, if of sufficient size; but the

type which seems to find especial favour among professionals is that known as the bellows shutter, which is fixed inside the

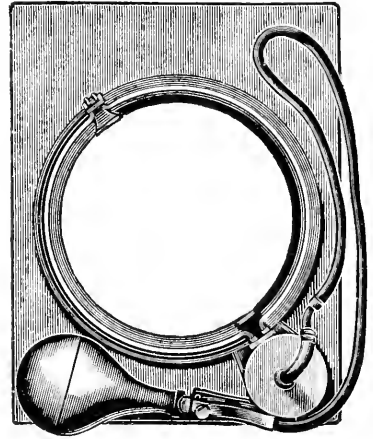

Fig. 120.—STUDIO BELLWS SHUTTER (OPEN).

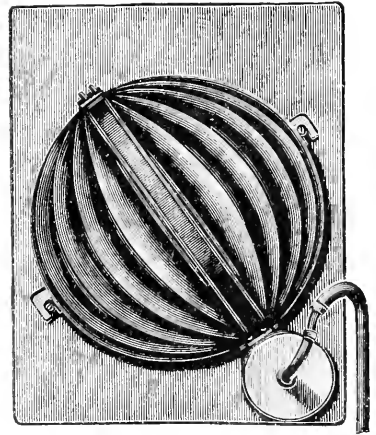

Fig. 121.—STUDIO BELLWS SHUTTER (CLOSED).

camera, behind the lens. Fig. 121 shows the shutter closed. Pressure on the pneumatic bulb causes the two segments of which it is formed to open in the middle and fly back (see Fig. 120). The shutter remains open as long as the bulb is pressed; the moment this is released it again closes. The turning of a lever or tap at the bulb end will compress the tube and prevent the return of the air, so keeping the shutter open as long as desired.

for a time exposure, without the necessity of retaining the hand on the bulb. The making of exposure shutters will be explained further on.

TESTING SPEED OF SHUTTER.

To test the speed of a shutter, photograph a small bright object attached to a wheel revolving at a known speed. With compasses measure the arc formed by this bright object during a revolution of the wheel, subtract the width of the image of the object when at rest, and find the proportion to the whole circle. The speed at

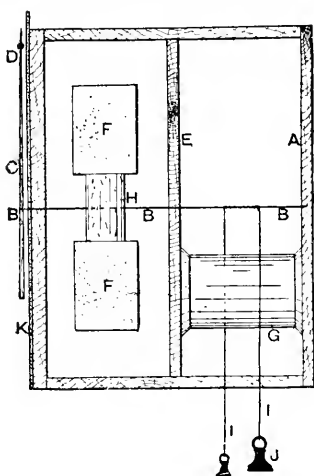

Fig. 122.—PEAL SPEED TESTER.

which the wheel is travelling being known, the length of the arc shows the duration of exposure. For example, fix a small piece of tinfoil to the outer edge of, say, the front wheel of a bicycle, and place it in the sunshine against something very dark, so that the tinfoil may reflect as much light as possible. Focus the wheel exactly 3 in. diameter, near the top of the $\frac{1}{2}$ -plate (a circle that size may be drawn in pencil on the focussing screen as a guide); cause the shutter at its lowest speed, and cease the wheel to revolve rapidly. See how many complete revolutions it makes in ten seconds. If possible, it should be made to go round ten times exactly; but, supposing it only goes eight, then it will make one revolution in $\frac{7}{8}$ sec. Release the

shutter immediately, close the slide, and move the camera slightly, so that the image comes $\frac{1}{4}$ in. lower. Rotate the wheel at exactly the same speed as before, and again release. Proceed in this way with each of the various speeds of the shutter, and then develop the plate. A circle should be drawn 3 in. in diameter, and the several arcs shown on the plate measured, the width of the image of the tinfoil at rest subtracted, and the result divided into the circumference. If the first goes ten times, then the speed will be $\frac{1}{10}$ of $\frac{1}{4}$ sec., or $\frac{1}{8}$ sec. Shutters work slower as the springs wear; these should be let down after use. Speeds frequently are over stated when sent out. A very convenient pendulum device for testing shutter speeds has recently been introduced.

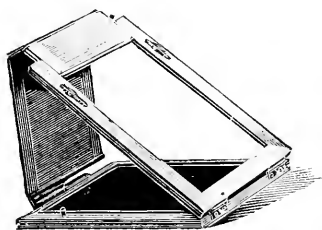

Fig. 123.—BOOKFORM DOUBLE DARK-SLIDE.

THE PEAL SPEED TESTER.

For accurately testing and timing shutters there is nothing simpler than the Peal device shown by Fig. 122. An ordinary deal box A is divided down the centre E; in the front is a cardboard dial K, and running smoothly from back to front is a knitting needle B, to which a wooden hand C is attached, having at its extremity a silver bead D. The dial is divided into 100 parts, and the hand is made to describe a circle twice in a second. To regulate the speed, the needle passes through a cork H, on either side of which is fastened a piece of card F, accurately balanced. The rotating power is a length of worsted or silk cord I, wound a few times round the needle; to one end is fastened a 4-oz. weight J, and a smaller one to the other, the cords being kept apart by a drum G. The time occupied in passing between two

points is noted, and the fans altered to give more or less resistance till this is exactly fifty seconds, during which time the hand should have made 100 revolutions.

DARK-SLIDES.

The usual form of slide fitted with a field camera is that known as the book-form, from the fact that it opens in the middle like a book (see Fig. 123). There is a dividing partition of metal or cardboard separating the two plates, which may or may not be removable. Care should be taken that the slides fit the camera properly, and are neither too tight nor too loose. The studio camera, on the other hand, is generally provided

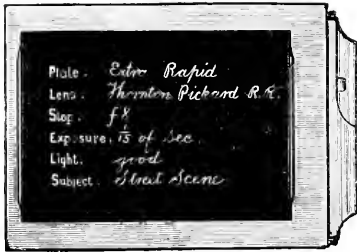

Fig. 124.—AMERICAN PATTERN DARK-SLIDE.

with slides of the single variety, holding one plate only, and allowing its introduction by a hinged door at the back. Some of the old-fashioned cameras are supplied with solid dark-slides, in which the plate is inserted by withdrawing the shutter, and retained in position by movable metal catches at the corners or sides. This is a bad form, for if the catches should happen to work loose and slip, the plate may fall out when the shutter is withdrawn. In dark-slides of the American pattern the plate is inserted by pressing a lever at the bottom, which falls back and allows the plate to drop into position (see Figs. 124 and 125). Metal dark-slides are very convenient for touring purposes, being remarkably light, and taking up little room. Cheap and light dark-slides made of cardboard are also obtainable, and are useful in an emergency, or for the construction of experimental apparatus. How to make

dark-slides will be explained in a later chapter.

ROLL-HOLDERS.

The roll-holder is an arrangement for carrying a length of celluloid or paper film, and fits the back of the camera like a dark-slide. It is very convenient when it is desired to use roll films with a camera intended for glass plates. Some cameras, however, are specially designed for use with a roll-holder only. The roll-holder occupies the same position with regard to films that the changing-box does with plates. With those cameras which are primarily intended for use with films a roll-holder is not required, the necessary mechanism for winding the film being provided in the camera itself.



Fig. 125.—LAYING PLATE IN AMERICAN PATTERN SLIDE.

FILM-PACKS, ETC.

There are various patents contrivances by which a number of cut films may be introduced together into the camera, without the aid of a dark-room, and exposed in succession. Among these may be mentioned the "Rajar" changer and the "Premo" film-pack, which are both highly ingenious in principle and satisfactory in operation. The convenience of being able to carry about any number of films ready for exposure as desired is certainly one which must appeal to the tourist photographer. It should be mentioned, however, that an adapter, or a slight alteration of the camera-back, is required before these contrivances can be used with apparatus not specially made for them or to which they have not been fitted. The "Rajar" changer can generally be adjusted to any camera without alteration being necessary. There are other arrangements for carrying a number of flat

lenses, but these generally require a special camera or holder, although, as a rule, very convenient and satisfactory.

VIEW-FINDERS.

The view-finder may be described as a tiny camera attached to the outside of a larger one, in such a manner as to enable the operator to see the view being taken without the necessity of looking at the ground glass. They are fitted to hand cameras principally, and may be of the box form or what is known as "brilliant."

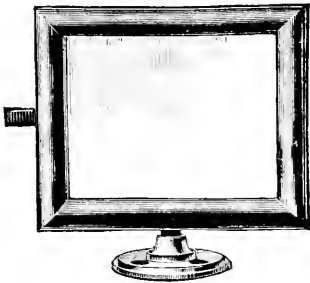

Fig. 126.—BI-CONCAVE VIEW FINDER.

The former are provided with a small lens, the view from which is reflected by a mirror on to a square of ground glass; the latter consist of an arrangement of prisms, or prisms and lens, and give an extremely visible and brilliant image. A third finder, is made on the principle of a rifle-sight, and requires to be looked through on a level with the eye. An adaptation of this description of finder is the bi-concave (Fig. 126), which consists of a small diminishing glass fitted in a rectangular upright frame. In cameras of the reflex variety the view is thrown upward on a full-size focussing screen by means of an inclined mirror, which can be turned aside out of the way during exposure (see Fig. 127). In the twin-lens cameras, which are provided with a pair of similar lenses, one

above the other, the upper lens is used for focussing and inspection of the view right up to the moment of exposure. Levels and plumb indicators may be obtained of various patterns for fixing on any camera, if not already provided; they should be correctly adjusted, or they will be a source of much confusion.

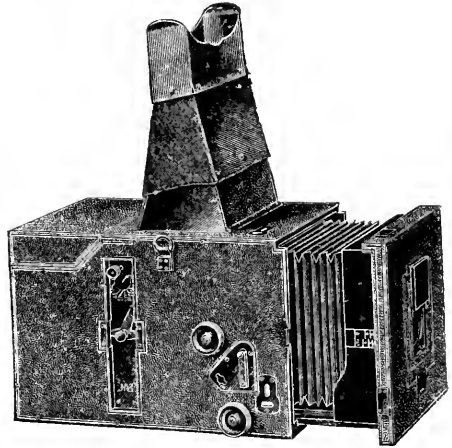

Fig. 127.—REFLEX CAMERA.

CONCLUDING REMARKS.

No attempt has been made in this chapter to deal with every variety of camera and accessory; these are so numerous and so diverse in action that the subject would require a volume to itself if treated exhaustively. The main principles of camera construction, and the leading classes into which the various cameras and appliances may be divided, have been sufficiently explained. Other special designs of cameras and accessories will be considered in their proper place. In many cases full working details have been given for making standard patterns, and these, no doubt, will prove of great practical use and interest.

PLATES AND FILMS.

HOW DRY PLATES AND FILMS DIFFER.

The photographic plate, as manufactured nowadays, consists of a sheet of glass coated with either gelatine or colloid containing sensitive salts of silver. The processes of manufacture may be divided into two sections, the emulsion processes and the bath processes. The bath processes are generally known as "Wet Plate," and will be described later. They are now scarcely ever used except for photo-mechanical work, for which they are preferred owing to the great contrast obtainable, and by itinerant photographers. Nearly all plates made nowadays are coated with emulsion, and are commonly known as dry plates. Films are sheets of celluloid, mica, or even gelatine, coated with an exactly similar emulsion to that used in the glass dry plate. The difference, therefore, between plates and films lies in the support only; the actual image-forming substance being the same. For either, therefore, the first requirement is to make the emulsion.

HOW THE EMULSION IS MADE.

Emulsions may be prepared with either of the silver halogens—bromide, iodide, or chloride. The iodide is seldom used except as an addition to the bromide, and the chloride is merely employed for the making of slow emulsions, such as may be used for lantern slides or printing purposes; for example, the ordinary gelatino-chloride paper or P.O.P., but as this is referred to in another chapter nothing further need be said of it. The gelatino-bromide emulsion, then, may be taken, either with or without iodide, as

a type of the proceeding to be followed. For the better understanding of the subject, and to avoid confusion of the operation, it should at once be stated that emulsion making may be divided into the following operations, which are usually conducted in the order given, although that order is not arbitrary.

COMPOUNDING THE FORMULA.

Simplicity will be the great recommendation for any formula, and that may at least be claimed for the one about to be given, as it contains nothing except what is absolutely essential to the production of the sensitive emulsion. It is as follows: (a) gelatine 30 grains, water 1 oz.; (b) silver nitrate 175 grs., water $\frac{1}{2}$ oz.; (c) potassium bromide 140 grains, water 1 oz.; (d) gelatine 240 grs., water 2oz. It will be noted that each of the ingredients is to be dissolved separately. An alternative formula, which gives a more rapid emulsion, is as follows: (a) Nelson's gelatine No. 1 soluble, 30 grs., water 1 oz.; (b) silver nitrate 175 grs., water $\frac{1}{2}$ oz.; (c) potassium bromide 130 grs., water 1 oz.; (d) potassium iodide 5 grs., water 1 oz.; (e) hard gelatine 240 grs., water 2 oz.

HOW SENSITIVENESS IS GOVERNED.

The first question likely to be asked by the novice is what governs the sensitiveness of the emulsion, and this may be broadly stated to be the ripening or boiling to which it is subjected. (There are, however, other methods of emulsion making which do not necessitate boiling; which will be dealt with later, but the principle is the same.) In order that this

boiling may bring about the required condition of the silver it is necessary that potassium bromide (KBr) should be in excess, and an examination of the formula should be made in order to ascertain whether that condition has been carried out. The equation given by chemists as taking place in the formation of silver bromide from potassium bromide and silver nitrate is stated thus:—

excess, it may be boiled for twenty minutes; or with 160 grains in excess, for seven minutes. If these times are exceeded, the emulsion commences to show signs of fogging, any trace of which would, of course, be exceedingly injurious. The increase of sensitiveness is said to be due to the enlargement of the particles, which may be explained by the theory of crystallisation. Just as a crystal of alum will grow in a saturated solution of the same substance, so the potassium bromide as a solvent of the haloids will cause growth of the particle. The particles, being

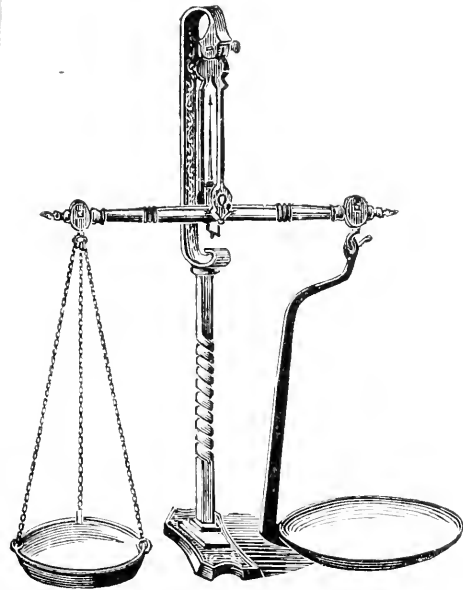

Fig. 128.—SCALES.

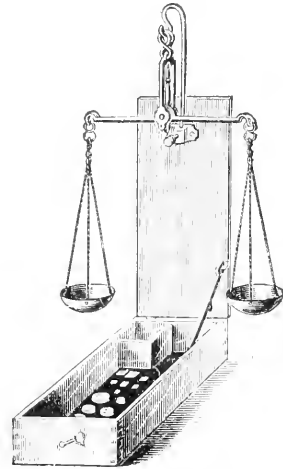

Fig. 129.—SCALES.

$$\text{AgNO}_3 + \text{KBr} = \text{AgBr} + \text{KNO}_3$$

$$\left(\frac{108+14+48}{170}\right)\left(\frac{39+80}{119}\right)\left(\frac{108+80}{188}\right)\left(\frac{39+14+48}{101}\right)$$
 From this it will be seen that 117 parts of silver nitrate react with 119 parts of potassium bromide. Therefore, the 175 parts given in the first named formula will react with 122½ parts of potassium bromide, thus leaving 17½ grains in excess of that actually required. Now it has been found that the length of boiling is dependent upon the amount of potassium bromide present; that is to say, the less potassium bromide in excess, the longer the emulsion may be boiled. For example, with only 1 grain in excess, the emulsion may be boiled for six hours; with 20 grains in

larger, are able to absorb more light; and, consequently, more work may be done, and a greater amount of silver reduced, in the same time, or by the expenditure of the same energy; therefore, the plate becomes more rapid. As this is a point that will be dealt with in a later section of the book, nothing further need be said on the subject, except that attention may be called to the fact that a similar explanation may be given as to why the proportion of emulsion on the plate affects the sensitiveness.

WEIGHING.

This must be done with extreme accuracy. The rough sort of weighing practised by many photographers is only likely to

lead to disaster. A chemical balance, the pattern shown in either Fig. 128 or Fig. 129 being quite suitable for this purpose, should be employed in preference to those in general use. It need not, however, possess the extreme delicacy of adjustment of the best of such instruments. Place filter paper on the pan of each scale. Having weighed out the substances, place each aside on a separate

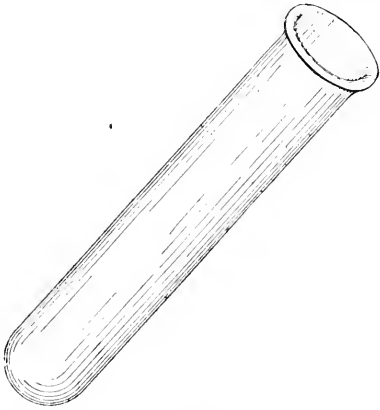

Fig. 130.—BOILING TUBE

paper: be careful not to get them mixed, although there should be no fear of doing so, except perhaps in the case of the gelatine, as the silver nitrate and potassium bromide are easily distinguishable crystals, the former occurring in flakes and the latter in cubes. In using a balance of the above kind, the substance should be placed upon the scales and then the arm gently raised. If the pointer indicates too much or too little, the arm should be lowered before the alteration is made. The 240 grains need not be weighed up at the present time. The other gelatine should be of a soft variety, Nelson's No. 1 being very suitable. Silver nitrate should be recrystallised and absolutely pure, while the same remark applies to the potassium bromide; needless to say, distilled water should be used throughout the operation.

DISSOLVING.

Pour a little water on the gelatine, contained in a beaker or a jam jar, rinse

round rapidly and drain off; this will get rid of any dust, otherwise liable to adhere to it. The silver nitrate is then added to $\frac{1}{2}$ oz. of water in a boiling tube, and the solution warmed until dissolved. The boiling tube is a test tube of rather large bore used for boiling solutions, as shown in Fig. 128. A strip of blotting paper, folded in four, is wrapped round it to form a handle. The potassium bromide will readily dissolve in cold water. The gelatine should now be covered with 1 oz. of water and allowed to swell for a few minutes, then placed on the water bath

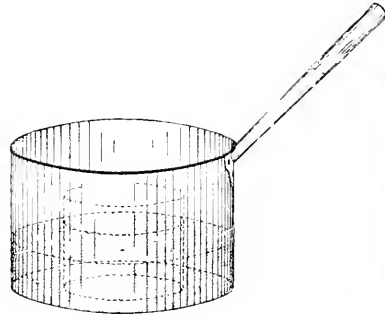

Fig. 131.—EMULSION POT IN SAUCEPAN.

until dissolved. Roughly speaking, a water bath much resembles a glue pot.

MIXING.

A suitable vessel must be obtained for mixing. It is, perhaps, more convenient that this should be opaque, or of a red, or orange colour. Further, it must have a wide mouth, to allow of stirring, and easy addition of other solutions. It must be glazed and free from cracks, preferably possessing a lid which can be made to fit down quite light-tight. Ointment pots, capable of holding 10 or 12 oz., certainly seem very suitable. There is a form, similar to that shown in the illustration, which has been found very convenient. Having chosen a suitable vessel, it must be stood in a saucepan or anything capable of holding hot water (see Fig. 131). For experimental purposes, an ordinary enamelled mug, now obtainable at most hardware shops, may

be used. The advantage over a saucepan is that there is no handle liable to be knocked against in the dark. When the gelatine is completely dissolved, which may be aided by stirring it all the time with a glass rod, pour in the silver nitrate, and beat up thoroughly together, to ensure its being completely mixed. All the operations up to this point may be conducted in ordinary white light; but the following, in which the emulsion is

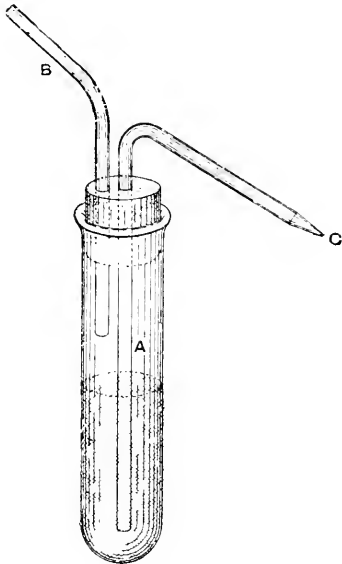

Fig. 132.—SPRAYER.

formed, must be carried out in a red light, of which the less the emulsion is exposed to the better.

SPRAYING.

The apparatus required for this purpose consists of a boiling tube, fitted with two bent glass tubes, as shown in Fig. 132. The tube (A) passes through a tightly fitting cork to the centre of the boiling tube at the bottom, and is drawn off to a fine point at c. This is done by holding the glass tube in a gas jet (an ordinary gas flame is better than a Bunsen for this purpose) until red hot, when the tube may

be pulled in two, which brings it to a fine point, as shown in Fig. 133. When cold the extreme end is snipped off, and leaves a tiny hole through which the solution can pass. The tube, B, remains above the solution, and by blowing through it the solution is forced up through the tube, A, and emitted in a fine spray. Fill the sprayer with the solution of potassium bromide, and insert the cork and tubes, so that the tube, A, is almost, but not quite, on the bottom; this will ensure all the solution being driven out. Hold the sprayer in the left hand, apply the lips to the tube, B, and blow through same, all the time stirring the gelatine solution vigorously with a glass rod. For stirring the emulsion, a glass spatula, or a flat strip of glass tied with white thread to a glass rod, will be found exceedingly useful. Do not get the spray too near, or



Fig. 133.—GLASS TUBE, SHOWING POINT.

it will not be sufficiently spread. Immediately the operation is commenced, a white compound will be seen to form in the gelatine, and the tendency it shows to cling together will be ample proof of the necessity for keeping the solution violently agitated. After adding a little of the solution in this manner, if the vessel is provided with an air-tight top, it may be put on. Holding the jar in a cloth, the whole should then be shaken violently. Continue adding the solution in this way, with intervals of shaking, until both are mixed. Too much emphasis cannot be laid upon the necessity of thoroughly mixing, as upon it depends the fineness of grain and indirectly the sensitiveness of the emulsion; for a badly mixed emulsion, consisting of coarse particles, will admit of little boiling and consequently be less sensitive. In the opinion of some, this is best effected by adding the solution little by little, as just described; but, on the other hand, a worker of considerable experience has stated that the best plan is to add

the whole of the solution straight away, and to rely entirely upon violent agitation of the mixture.

BOILING AND TESTING.

Whichever is done, the emulsion is again placed on the water bath and the latter raised to boiling point. Two or three times during the boiling of the emulsion, the jar containing it should be lifted out covered up, and shaken violently. Before commencing boiling, the glass rod used for mixing should be smeared across a sheet of plain glass, and then viewed by daylight. If the emulsion has been properly mixed, it should have an orange red tint by transmitted light. At intervals during the boiling of the emulsion, further smears should be made side by side on the same glass, and again examined in daylight or white light. It will be found that the tint of each of these differs, and directly the emulsion shows signs of a blue tinge by transmitted light, boiling should be at once stopped, or chemical fog will set in. About twenty minutes boiling will be a safe time, with the formula given above. The 240 grains of gelatine, which should be of a hard variety, that is, having a high melting point, may now be dissolved in the quantity of water stated, and added to the emulsion before washing. But, on the whole, it is perhaps preferable to complete the washing before doing so. If the samples of emulsion taken as tests during the boiling are placed under a high power microscope, they will prove exceedingly interesting, for the gradual enlargement of the grains will be apparent by comparing them. The sensitiveness of the emulsion may be increased still further by digesting for from twelve to eighteen hours after boiling and before freeing from the potassium nitrate.

SHREDDING AND WASHING.

Now this potassium nitrate, if allowed to remain, would practically destroy the sensitiveness of the emulsion, and must therefore be removed. Fortunately, it is very soluble, and may be easily washed

out. An hour's washing in distilled water is ample to remove every trace, and even less than this may be considered safe. Of methods of washing, there is practically a choice of two. In the first the emulsion is broken up into a convenient form for dealing with, either scraping with a silver fork or squeezing through canvas or coarse netting. The shreds should measure about $\frac{1}{2}$ in., and they are then well soaked for several hours according to the practice of some workers. In the other method, the plates are coated while still containing the potassium nitrate, and are then washed in a tank, in the same manner as a negative may be dealt with. In any case, the emulsion should not be used at once, but should be set aside for a day or two; as a further ripening goes on, resulting in an increase of speed. It is a good plan, when adding the bulk of the gelatine of the emulsion, to include 2 grain of Thymol dissolved in one dram of alcohol. This is used as a preservative. The question might be asked, why the bulk of the gelatine has not been added in the first instance. In reply it may be stated that gelatine loses its power of setting when kept for a length of time at a high temperature, so that the less heating it has the better. Especially will this be the case, if the emulsion is to be used a little at a time, and consequently to be warmed up repeatedly. Sufficient only of the gelatine should be added, therefore, to form the emulsion.

COOLING OR PRECIPITATING.

When the boiling has proceeded sufficiently far, the vessel containing the emulsion is set aside in a dark cupboard to solidify and ripen (by ripening is meant the increase of speed which results from keeping); or it may be precipitated immediately by the use of alcohol. The best plan perhaps is to pour out the emulsion into a flat dish. The dish should be one scrupulously clean, and preferably one which has not been used for any other purpose. A flat porcelain or glass dish, similar to those used in developing, will answer well. A form often employed is



EFFECT OF BROMIDE IN OVER-EXPOSURE.

(PRINT FROM TWO HALVES OF OVER-EXPOSED NEGATIVE; THE LOWER HALF DEVELOPED WITHOUT BROMIDE, AND THE UPPER HALF WITH A SMALL QUANTITY.)



EFFECT OF INTENSIFICATION IN UNDER-EXPOSURE.

(THE RIGHT HALF OF THIS PICTURE IS PRINTED FROM AN UNDER-EXPOSED NEGATIVE BEFORE INTENSIFICATION, THE LEFT HALF HAS BEEN SLIGHTLY INTENSIFIED WITH MERCURY AND AMMONIA.)

shown in Fig. 131; even a pie dish may be used, but it is open to the objection that the enamel is usually not good, and frequently cracked. In any case, enamelled iron dishes should not be used. The advantage in using a dish, over a beaker or jar, is that it presents a much larger surface to the air, and consequently sets more rapidly. At the same time, it must be remembered that the emulsion should be placed in a cool place where there is a free passage of air, otherwise it will not set for a considerable time. Do not shut it up in a box, or in a close cupboard. After about two hours the emulsion will have set, the actual time varying with the temperature and the dryness of the air, as

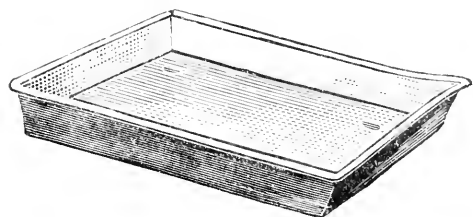

Fig. 131.—FLAT DISH FOR RIPENING EMULSION.

will no doubt have been gathered from the foregoing remarks. In commercial practice it is usual to cool the emulsion with ice water, as the effect is better. The principle is explained in a later section. The precipitation of the emulsion by means of methylated spirits or alcohol is a method introduced by a well-known firm of plate makers, but is very little practised at the present day. For this purpose, ordinary methylated spirit may be used (preferably of low specific gravity), not containing gum. Some workers recommend an equal quantity of alcohol or spirit, whilst others prefer to use double the quantity. Of the two methods, the latter is perhaps the safer, as the great desideratum is to completely remove the soluble nitrates. Take, then, twice as much alcohol as of water used in the making of the emulsion. In the present case, 5 oz. should be used. The bottle, or

other closed vessel, containing the emulsion, is then violently shaken, so as to completely impregnate the solution with the spirit. As this proceeds, the spirit having a strong affinity for water will extract it from the gelatinous matter, with the result that it subsides to the bottom of the vessel (on allowing the solution to stand), in the form of a thick pasty mud. In removing the water the soluble nitrates are removed also which remain dissolved in it. When working on a large scale, the spirit may be saved, so as to be re-distilled for use again. It has been said, however, that this method, although offering as it does many advantages in the way of simplicity, is not so applicable to the preparation of rapid emulsions on a small scale. The soluble nitrates do not appear to be so effectively removed as may be done by washing. Supposing, therefore, that washing the emulsion is the method adopted; after allowing it to set in the dish as already described, it is redissolved and cooled down to a temperature of about 70° to 80° F. This may be done by allowing a stream of cold water to run down one side of the vessel containing it. The 240 grs. of gelatine are now rapidly rinsed in a few changes of distilled water to free it from dust or any adherent matter, and then covered with 2 oz. of distilled water and placed in a water bath, the temperature of which should only be sufficient to dissolve it properly. Something about 100° F., probably. Do not be in too great a hurry for the gelatine to dissolve. The less heat used in dissolving this the better, as it is liable to lose its power of setting properly. When thoroughly dissolved it is added to the emulsion and shaken violently. It is now ready for filtering.

FILTERING AND FILTERS.

For this operation a water jacket will be necessary. Such an arrangement is shown in use in Fig. 135. It consists of a copper vessel, of funnel shape, supported on three legs, out of the side of which comes a tube by means of which the water may be kept warm. The temperature of the water may be taken through the hole shown at the top near the edge of the rim. For the experi-

menter of slender means, a satisfactory home-made arrangement is shown in Fig. 136. A fairly stout can, such as are used for packing preserved meat, is taken, and a hole punched in the bottom about the size of a halfpenny. In this is tightly fixed a good cork, through the centre of which has been pierced a hole of sufficient size to tightly fit the tube of the funnel. A second hole, sufficient to accommodate another similar cork, may be punched; and through this, after boring the hole to a proper size, is put a small glass

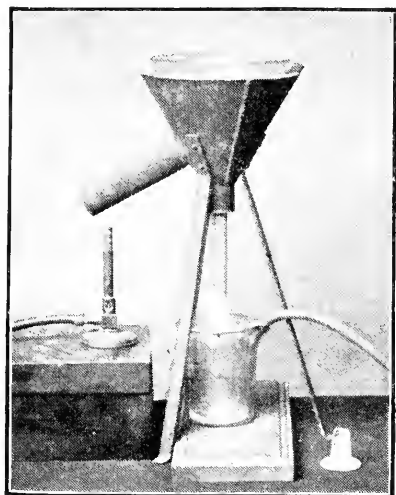

Fig. 135.—WATER JACKET.

tube with tap, such as is used in a burette. This, however, is not absolutely necessary. The arrangement will answer very well without it, but if one is at hand by all means use it, for it is a convenience. If desired, a rim of tin may be placed over the top to cover in the hot water. The water jacket is now ready. If a Bunsen or a small lamp flame is available to place beneath the jacket, all that is necessary is to fit the funnel through the opening in the cork, and through the cap or sheet of metal, filling it nearly with cold water through the opening at the top by means of a second funnel. When the water is sufficiently warm, the filtering medium and the

emulsion may be poured in. Another plan is to pour hot water into the jacket, and proceed at once with the filtering. If this is done, the tap fitted to it will be found an advantage, since the water as it cools may be run off and a fresh supply poured in without upsetting the filtering arrangements.

APPARATUS FOR KEEPING TEMPERATURE CONSTANT.

Another method of keeping constant the temperature of solutions is by means

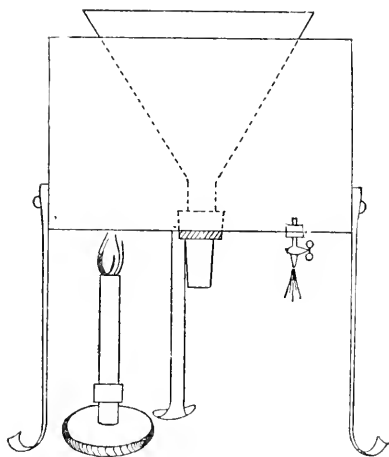

Fig. 136.—HOME-MADE WATER JACKET.

of the apparatus shown in Fig. 137. This consists of a glass funnel around which is coiled india-rubber tubing, fastened by means of thin wire, so that one end may be attached to the hot water supply, while the other, allowed to remain free, runs off into the sink. An efficient and permanent heating arrangement may be made by coiling compo pipe around a tin plate funnel and using an inner glass funnel for filtering. Steam or hot water is passed through the coil of pipe. The apparatus might be made with glass tubing, if preferred, by anyone accustomed to bending this. A block of the same shape would be necessary, around which the tubing could be allowed to fall as it

warmed. There are several operations in photography where this method might be useful. The next consideration is the filtering medium; some workers recommending one, and some another. For this purpose, washed wool and chamois leather are equally good. It is essential that filtration should be thorough, and although the emulsion may be made to run more quickly through wool, it is possible the operation may have to be repeated, so that there is no advantage in the end. A good practice is to use swansdown

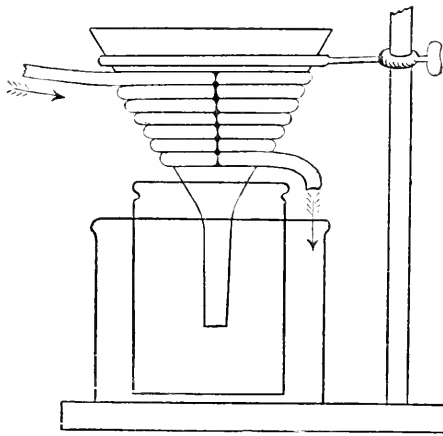

Fig. 137.—RUBBER ARRANGEMENT FOR HOT FILTRATION.

calico, washed in soda water, rinsed, and dried. Various methods have been suggested for forcing the emulsion more rapidly through the filtering medium, by means of some pneumatic arrangement or by sucking it through by means of a filter pump (see Fig. 138), but filtering is a tedious process. At Fig. 135 it will be noted that the emulsion filters into a yellow glass bottle, which is standing in a beaker of hot water. When the tubing arrangement is used, or the small tap as shown in Fig. 136, this is supplied easily from the vessel above. Filtering completed, the emulsion may at once be placed on the plates, regardless of the fact that it still contains the soluble nitrate, and is in an unwashed condition.

CLEANING THE PLATES.

Whilst the emulsion has been filtering, the plates are cleaned and prepared ready for coating. For this purpose, it is possible to use old negative glasses; that is, those from which the film has been removed; but it is far better to procure some sheets of new glass, as besides the fact that the waste of time in cleaning the plates almost or quite equals the cost of new stuff, there is always the danger of chemicals still remaining on the glass,

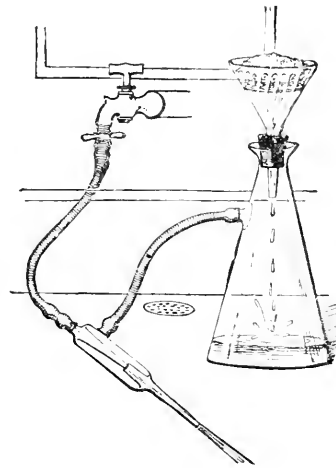

Fig. 138.—FILTER PUMP.

despite the fact that it may have been most scrupulously cleaned. There may also be scratches on the old plates. These would give rise to unaccountable spots and even more curious appearances on photographic plates. One photographer, who had exposed a plate on an open landscape in Switzerland, was alarmed to find, on development, a superimposed image of a lady in evening dress, whose costume and features were entirely unknown to him. The explanation was, no doubt, quite simple. The plates were coated upon old negative glasses, and still preserved some reducing power from their former image. This is, of course, a thing which is hardly likely to occur in any large factory. In choosing glass for coat-

ing great care must be taken, first, that it is of correct thickness; secondly, that this thickness is uniform; and thirdly, that it is entirely free from striæ, bubbles, etc., as these usually come on some important part of the negative, and seriously affect the definition. The size of the plates is not important, so long as they

plates being then stood in a rack to dry spontaneously. The plates should not be rubbed dry, as friction seems to prevent the proper adhesion of the emulsion. When dry, the next operation is to edge them with india-rubber solution to prevent

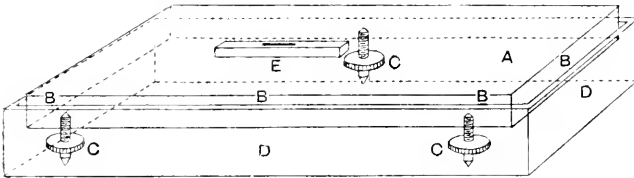

Fig. 139.—LEVELLING SLAB FOR COATING PLATES.

are not too large to handle conveniently. They may be cut up to suitable sizes afterwards. The size most useful may be multiplied by a number leaving a slight margin to trim off, as the emulsion is sometimes not coated nicely at the edges. Odd sizes are inconvenient, as the amount of emulsion poured on the plate is in direct proportion to its area.

PREPARATIONS FOR COATING.

In coating the plate, the first requirement is a levelling slab. The best form consists of a glass slab of patent plate A (Fig. 139), resting on a frame B, supported by three leveling screws C. This can be adjusted to a nicety, and may if desired be home-made. The details will be gathered from an examination of Fig. 139. This may with advantage be allowed to stand in a wooden dish D of sufficient size to allow of the screw C being easily manipulated, according to the indications of the spirit level E. All that is necessary is to place the glass on the screws with a spirit level in the centre, and adjust one or other of the screws until quite level. To clean the glass, first wash it in a weak solution of caustic soda, rinse, and immerse in a weak solution, say 1 per cent., of nitric acid, again washing thoroughly. The final washing is best done in hot water, the

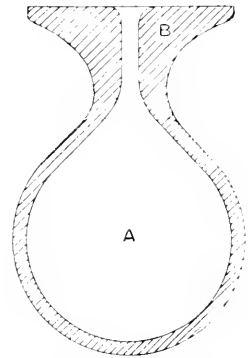

Fig. 140.—PNEUMATIC HOLDER.

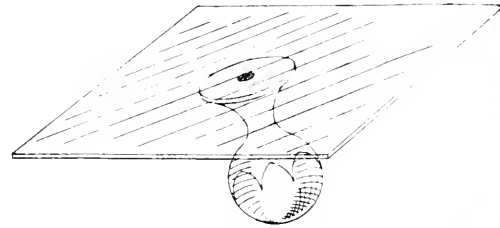

Fig. 141.—PNEUMATIC HOLDER AND GLASS PLATE.

frilling. Frilling is probably one of the most serious troubles the experimental plate maker will have to contend with. It consists of an irregular expansion of the gelatine around the edges of the plate, causing it to pucker up and leave the glass. Once started, unless immediate pains are taken to harden the film and arrest its progress, the latter is liable to completely leave its support and float off into the solution. The most likely time for such frilling to occur is in the hypo. bath, particularly if the weather is very hot or very cold, or the solutions of uneven temperature. In bad cases of frilling it will even start in the developer. To ensure a proper adhesion of the film to the glass is, therefore, most important.

COATING THE PLATES.

Plate coating in factories is done by machinery, but in experimental work hand coating will answer quite well. It is pos-

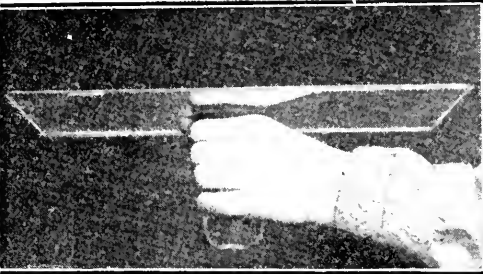

Fig. 142.—COATING PLATE, FIRST POSITION.

sible to coat 60 plates in an hour by hand, and, in fact, until about fifteen years ago, the majority of the work was done in this way. A pneumatic holder, similar to that shown in Fig. 140, will be useful. This consists of a collapsible rubber bulb A with a flat top B. The bulb is pressed, the plate laid on the top, and the bulb released, when it holds firm by suction (see Fig. 141). In use, the holder should be placed in warm water until ready, as otherwise the chill is liable to cause a

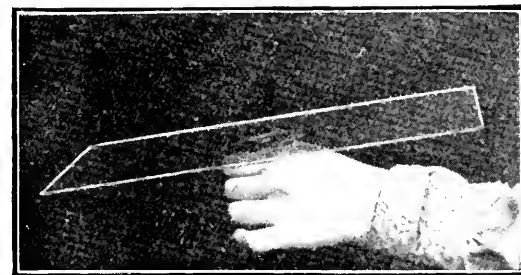

Fig. 143.—COATING PLATE, SECOND POSITION.

slight unevenness in the coating. A pool of emulsion, about equal to one-third the area of the plate, which should be warmed, is then poured in the centre of the plate, and by tilting it very gently the emulsion is caused to flow first to the top right hand corner, next to the top left hand corner, then to the bottom left hand corner—taking extreme care to do this slowly, as otherwise the emulsion will run

over on to the arm—then finally to the bottom right-hand corner, pouring the excess into the coating pot. Figs. 142 to 145 will make this clear. If a certain quantity of emulsion be taken in a warm measure,

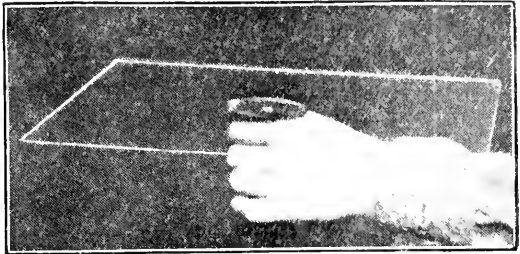

Fig. 144.—COATING PLATE, THIRD POSITION.

and poured from it, the amount used being noted, it will be found that about 80 minims are required to each half-plate or its equivalent. Coating pots resembling a teapot were at one time obtainable,



Fig. 145.—POURING OFF THE SURPLUS EMULSION.

consisting of an inner and outer vessel, the latter being filled with warm water and the former with emulsion. The latter may be poured from such a contrivance without fear of bubbles forming. The plate can now be put in the washing-tank, which should be filled preferably with distilled water, and allowed to remain for half an hour, giving one or two changes during that time. It may then be removed,

and if the operator is possessed of a drying cupboard it should be placed in it until thoroughly dry.

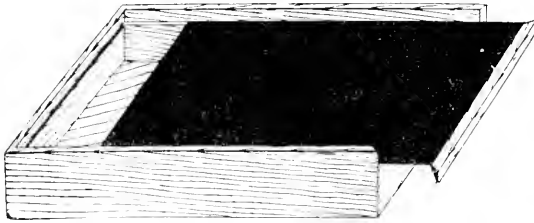

Fig. 146.—DISH WITH SLIDING BOARD.

RAPID DRYING WITH SPIRIT.

When working experimentally, the plate may be dried by the aid of methylated spirit. Have at hand a perfectly clean

this way, the best plan is to take a 20 in. by 16 in. dish (preferably a wooden one with a glass bottom, as these are flatter and economise the solution), which will accommodate ten half-plates side by side, requiring about 80 oz. of spirit. The plates are laid gently on scrupulously clean blotting paper for an instant, and the backs are then well wiped before placing them in the solution. When dry, the plate is ready for exposure. Drying usually occupies about fifteen minutes. The dish should be provided with a sliding board, to prevent evaporation and exclude light, as shown in Fig. 146.

MACHINE FOR COATING PLATES.

In coating plates by machinery, the apparatus invented by B. J. Edwards, and patented June 5th, 1884, is still used, with only slight modifications. This apparatus is shown in Fig. 147. It consists of a trough

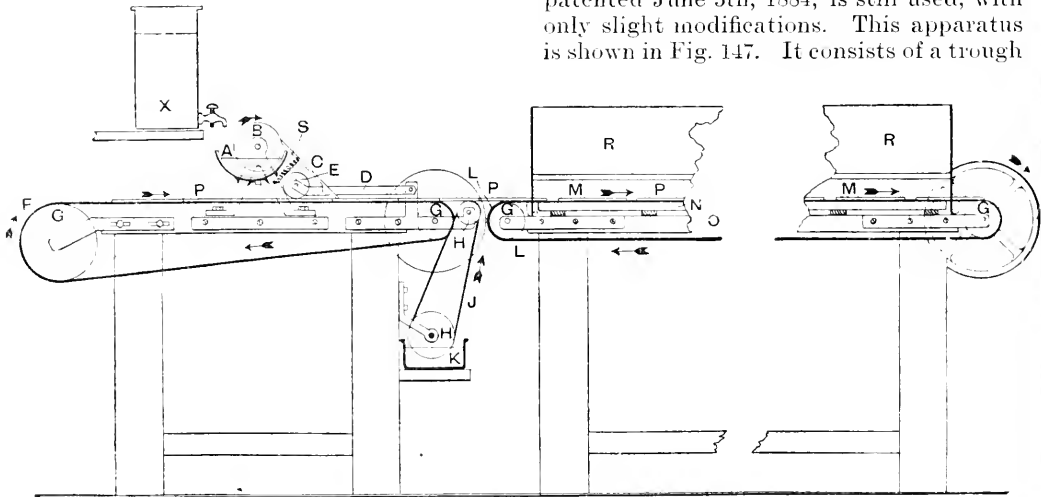

Fig. 147.—PLATE COATING MACHINERY.

dish, into which pour sufficient spirit to well cover the plate. If a half-plate is used with a half-plate dish, about 6 oz. will be required; while larger dishes will require a proportionate amount. Entire absence of dust is essential, so that the spirit should be carefully filtered before use. It is a good plan to pour the spirit each time after use back to the jar through a funnel, in the neck of which has been loosely placed a small tuft of cotton wool. Where several plates have to be dried in

A for holding the emulsion. The trough is silver-plated, and is supported between two uprights, as shown, and in it revolves a roller B carrying around with it a coating of the emulsion, which flows into the trough from the tap in the reservoir X fitted above. At C is fixed a movable scraper, which is so arranged as to take off a layer of emulsion from the roller. This scraper is carried by the pivoted frame D. It is made to press against the roller by means of two springs S, and can be placed

at any desired angle. Its width must be the same as that of the plates to be coated. The emulsion thus scraped off the roller flows down it on to the glass plate *P*, the thickness of the coating being controlled by the speed at which the plates travel past. The scraper may be placed at different heights to accommodate glasses of different thickness, and this is effected automatically by two side rollers. A guiding roller *E* brings the plate into exact position below the scraper. The plates are moved along below the scraper by means of an endless travelling band *F*, which is carried by the rollers *G*. Another endless band *L* passes around the two rollers *G* and carries the plates through a cooling chamber *M*, a tunnel-shaped compartment, open only at each end, which may be supplied with cold air. These bands are so arranged that in travelling from band *F* to band *L* the plates are separated slightly as shown. This is effected by the band *L* being made to travel at a slightly greater speed than the band *F*. Beneath *L*, or immediately under the plates, is a cold slab *N*; *O* is a metal tray in which the slab rests, which may be filled with ice-water. By a similar ice-tank *R*, just above the plates, the air in the chamber *M* is kept perfectly cool. An ingenious arrangement is shown in the centre of the illustration for

CLEANING THE PLATES.

Two rollers *H* carry an endless band *J*, which travels through a vessel of water *K* and effectually removes any emulsion that may find its way on to the back of the plate. This band also touches the band *F*, for the same purpose. The bands *F* and *J* are made of rubber, but the band *L* is made of woven wire, in order that the plates may be cooled at maximum speed. The tunnel chamber *M* is about 15 ft. long, so that the setting or stiffening of the plate may be assured before it is removed from the endless band. This is the kind of machine in use in many large factories, and with it an enormous amount of coating may be done in a surprisingly short space of time, with absolute uniformity and precision.

MELTING DOWN STOCK EMULSION.

From the description given, it will be seen that the operation goes on almost automatically, little or no attention being necessary beyond seeing that the emulsion trough is kept filled from the reservoir above, and that the plates are removed for drying when they reach the end of the ice-chamber. In working on so large a

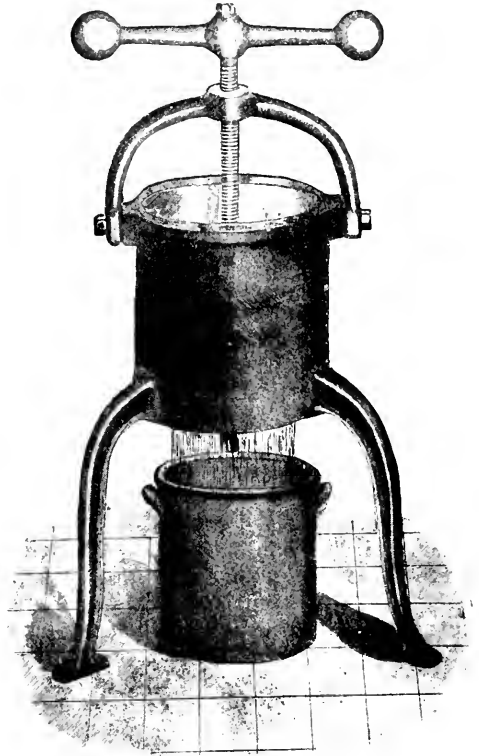

Fig. 148 — EMULSION PRESS.

scale, it is usual to make a stock emulsion and to melt it down as required. To facilitate this, an emulsion press (Fig. 148) is used. The emulsion is placed in this, and is squeezed through holes in the bottom by means of the plunger. The body of the press and the plunger are made of an aluminium alloy, which does not affect the emulsion — an important consideration which ought not to be overlooked.

EMULSIONS RIPENED WITH AMMONIA.

Fairly rapid plates may be made without employing the boiling process at all, by treating them with ammonia. Such plates, although not extremely sensitive, are considerably quicker than collodion plates. They may be prepared by treatment at a temperature of about 100° F., or the emulsification and subsequent treatment may take place at ordinary temperature. The former does not appear to possess any advantage over the usual method of boiling, but the latter certainly gains much as regards simplicity. The following solutions may be made up:—No 1. Silver nitrate, 175 grs.; water, 1 oz. No 2. Potassium bromide, 140 grs.; water, 1 oz. No. 3. Gelatine, 45 grs.; water, 1 oz. Add to No. 1 solution a little ammonia, and a precipitate of silver oxide is formed. Continue to drop in ammonia and shake the solution until the silver oxide, which is soluble in ammonia, is re-dissolved. It makes the operation a little simpler if the ammonia is diluted with a small quantity of water. This solution is added to No. 3, and shaken vigorously. When an intimate mixture is assured, the bromide solution, No. 2, may be added, a little at a time, with much shaking. Two hundred grains of gelatine are then dissolved in 2 oz. of water, and when cool added to the solution in the same manner. As in the preparation of other emulsions, the more complete the mixture the better. When this has been properly done, the emulsion should be set aside for twenty-four hours to ripen. Before doing so, it is best to pour it out into a flat glass dish, so that it may be in a convenient form for breaking up and washing. This is done as described on p. 64. The emulsion may be made with the whole of the gelatine at once, but in this case the temperature of the solution will have to be raised, or it will be too thick to allow of proper mixing.

ORTHOCHROMATIC PLATES.

These are plates specially prepared to give a truer rendering of the colour intensities, and to overcome the well-known defect of blue photographing too light and

yellow too dark. The subject of orthochromatic photography will be dealt with later, so that nothing beyond practical points in the preparation of the plates need be given here.

METHODS OF PREPARATION.

The object being to prevent certain colours photographing too dark, the special qualities of such plates must be that they are more sensitive to the rays of these colours. This increased sensitiveness is brought about by the action of certain organic compounds—dyes—which are capable of entering into combination with the silver to form a new compound having the desired special sensitiveness. There are, however, other and different explanations of the precise action of these dyes, which will be dealt with in the portion of this book devoted to theory. The dyes are numerous, and have varying effects. Erythrosine is a favourite for increasing the sensitiveness to yellow light, and erythrosine with cyanine to increase its sensitiveness to red. The dye may be added to the emulsion, or the plate after coating may be immersed in the dye solution. The latter is the better method for work on a moderate scale, and may be done as follows: Take 200 parts of distilled water, 25 parts of a 1 in 1,000 solution of erythrosine, and add 6 parts of ammonia (specific gravity '880). The plate, carefully dusted, is immersed in this solution for from one to one and a half minutes, then swilled under the tap, and dried in a proper drying cupboard or on a shelf in a well ventilated dark-room. The plate is then ready for exposure. In some cases the plate may be exposed straight away as soon as drained—that is, without waiting for it to dry.

LANTERN AND PROCESS PLATES.

These are plates which in the one case should have an extremely fine grain, and in the other should give a dense deposit exceedingly opaque, so that extreme contrast may be obtained when photographing drawings and similar subjects possessing only a short range of contrast. Both these

qualities are obtainable from the same emulsion. An extremely slow emulsion gives an extremely fine grain and a very dense deposit and contrast. Therefore, the sensitive coating is very similar, except that in the lantern plates the coating is very much thinner, and in the process plate the coating is heavier than in an ordinary dry plate. In development the plates are treated quite differently, as will be explained later.

MULTIPLE-COATED PLATES.

With a view to obtaining extreme latitude in exposure, plates have been prepared, and are still sold, which are coated with several layers of emulsion, each being of a different rapidity. The least sensitive emulsion is laid next to the glass; on top of this comes a coating of medium rapidity; and over these is laid an exceedingly rapid emulsion. The principle of such plates is that where the light is feeble it is capable of penetrating the emulsion, and therefore acts only on the top coating. As the light is stronger or the exposure is prolonged, it penetrates to the second or third coatings, which are capable of giving proportionately greater density in a shorter space of time in the developer.

THE WET COLLODION PROCESS.

As explained in an earlier section, this process consists of forming silver iodide or bromide in the pores of a film of collodion on glass and exposing in the camera while still wet. For ordinary photography in the studio or in the field the process is obsolete; but it is still used for certain kinds of technical work, such as the making of enlarged negatives, the making of negatives for printing process blocks, and for microscopic work. In the first case it possesses the advantage of cheapness, in the second it is preferred on account of the great density of deposit obtainable, together with the extreme clearness of shadows, and in the last instance on account of the fineness of its grain, and therefore its advantage in rendering exceedingly fine detail. It is possible that extreme competition in plate-making, and the consequent cheapness of all kinds of

plates, may result in discounting the first advantage, while the modern process plate certainly runs it very close as regards the second and third qualities. It is probable, therefore, that it will gradually fall out of practical use.

NATURE OF COLLODION.

A brief explanation of the substance from which collodion is made—pyroxyline—is necessary to a proper understanding of the subject. Pyroxyline, or gun-cotton, to use its more familiar name, is formed by the action of nitric and sulphuric acids upon cotton, paper, and other substances. Generally speaking, cotton is employed. Now these acids have a strong affinity for water, and therefore are capable of combining with the hydrogen and oxygen in the cotton to form a new compound, leaving the cotton in a dry, crisp state, quite different from its condition before treatment, and highly inflammable. If the acids are allowed to act sufficiently long, the insoluble explosive gun-cotton is formed. The theoretical part of the subject will be dealt with later, so that the preparation of the pyroxyline may at once be described. If, however, the student has no knowledge of chemistry, he should defer his attempts at this class of work until he has carefully mastered the principles laid down in the theoretic section, since the preparation of pyroxyline is dangerous to the inexperienced, on account of its highly explosive nature.

PREPARATION OF PYROXYLINE.

Ordinary cotton is contaminated with certain impurities which must first be removed. Take 1 oz. of cotton-wool and place it in a beaker. Cover this with a strong solution of washing soda, and boil it gently in this for a few minutes. It should then be well washed, first with ordinary water and finally in distilled water. If thoroughly done, this will completely remove all the resinous matter contained in the cotton, which should now be made perfectly bone-dry by baking in an oven. The cotton is next immersed for from eight to ten minutes in a bath of nitric and sulphuric acid. This operation should be

performed in an upright vessel, preferably a beaker, as it has to be kept at a temperature of 110° F. on a water bath. An ordinary gallipot, if the glaze is good, will answer the purpose. The bath is made up of: Sulphuric acid, 18 oz.; nitric acid, 8 oz.; and water, 1 oz. As it is dangerous to add water to sulphuric acid, the water should first of all be placed in the vessel, then the nitric acid, and lastly the sulphuric acid.

CONVERTING THE WOOL.

The operator should be provided with a stout apron and gloves, or finger-stalls

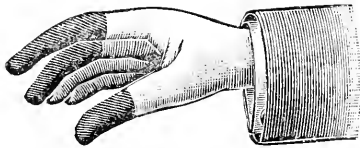

Fig. 149.—FINGER STALLS.

(see Fig. 149), and the wool must be manipulated with a couple of glass spoons or spatulas—or strips of glass may be used. The wool should be rolled into little balls and plunged completely under the surface at once. When sufficiently soaked, the excess is squeezed out and the wool washed in running water for twenty-four hours, or until it ceases to show an acid reaction when tested with litmus paper. This will indicate when the excess of acid has been removed. It must now be again dried.

QUALITIES OF PYROXYLINE.

Pyroxyline properly prepared should show a gain in weight of about 25 per cent. over the original cotton. Fortunately, it is not necessary or advisable to prepare one's own pyroxyline, as it can be purchased at from 1s. to 2s. 6d. per oz. The proper consistency of the collodion is partly dependent upon the preparation of the pyroxyline. The greater the proportion of acids used, the heavier and more glutinous will be the collodion, and *vice versa*. The disadvantage of the heavier sample is its tendency to curl up and leave the plate. It may, however, be used for enamelling.

PREPARATION OF COLLODION.

Collodion is formed by dissolving pyroxyline in equal quantities of alcohol and ether. For this take pyroxyline, 2 drams; alcohol (S_{20}), 10 oz.; and ether (T_{25}), 10 oz. The alcohol is poured over the pyroxyline in a vessel with a closed top, and the ether added to it. The proportions are not arbitrary, but form a good average. In cold weather the proportion of ether may be slightly increased (with a proportionate decrease of alcohol), with advantage. Further, the consistency for special work may be varied by altering the proportions of the solvents. It is sometimes recommended to refine the collodion by precipitating and re-dissolving; collodion so prepared having a finer texture. To do this, the collodion is poured in a thin stream into distilled water, and the precipitate collected and redissolved in the same proportions of ether and alcohol. If the precipitate is dried and weighed, as it should be, it will be found to be lighter, showing that all the pyroxyline was not precipitated. Hence the alteration in its condition.

IODISING THE COLLODION.

Collodion may be either iodised or bromised. The former gives density and the latter detail; that is to say, the iodide gives a heavier deposit of silver in the lightest portions, and the bromide a more even density. For such work as the process is now used for, iodised or bromo-iodised collodion answers best. Collodion may be purchased in a plain state or iodised, or with the iodiser done up separately. A simple plan is to dissolve some ammonium iodide in a little alcohol in the proportion of 4 grs. to each ounce of collodion, and then to add it to the collodion, when it may be used at once. Where the collodion is likely to be kept a considerable time, 5 grs. per ounce of cadmium iodide may be substituted. If, however, a bromo-iodised collodion is preferred, the following is a good formula: Cadmium iodide, 3 grs.; ammonium iodide, 18 grs.; ammonium bromide, 10 grs.; and collodion, 6 oz. If desired, the proportions of iodide and bromide may be varied according to the

density or detail required. Collodion so prepared is better for keeping a few days before use.

THE SILVER BATH.

The quantity of silver solution to be prepared will depend upon the size of negatives to be made, but about 20 oz. will be ample for ordinary purposes. A very small quantity of solution may be used if the sensitising is done in a flat dish, but the dangers of dust are so much greater that it cannot be recommended. The making up of the silver bath is a very simple matter, but there are certain points which must be borne in mind. For example, the bath may be either acid or neutral, its condition in this regard being governed by the sensitive compound used. If the iodide is used, so that the sensitive salt in the film consists wholly of silver iodide, the bath may be in a neutral state; if the iodide and bromide are used together, then the bath should be faintly acid; and if bromide alone is used, it must be more strongly acid. The safest plan, at any rate for a beginner, is to have the bath faintly acid even when using the iodide only. The action of the nitric acid is to prevent the spontaneous or independent reduction of the silver, thereby keeping the shadows clear and free from fog. The proper strength for the bath in ordinary circumstances is 40 grs. per ounce; therefore, to make up the bath, take 320 grs. of recrystallised silver nitrate and dissolve in 8 oz. of distilled water.

IMPORTANCE OF A PURE BATH.

The purity of the chemicals employed for the bath is very essential. Silver nitrate is usually tolerably pure, but may be distinctly acid; this may be neutralised by the addition of a little chalk, after which the bath should be filtered. This acidity, however, is not a serious drawback. Distilled water is sometimes contaminated with organic matter, which should be got rid of by dissolving the silver nitrate in it and then exposing to sunlight, when the organic matter will be destroyed and some of the silver precipitated. When distilled water is not at hand, ordinary water may

be used, and the solution filtered. In either case, however, allowance must be made for the loss of silver, which may be ascertained by use of the argentometer, a kind of hydrometer specially made for testing the amount of silver in a given quantity of solution, as will be explained in a later section.

SATURATING WITH SILVER IODIDE.

Now if a bath were made up as directed above, the first plate immersed in it would give only a thin, weak image, and would be practically useless. This is because silver iodide is soluble to a very slight extent in silver nitrate. Therefore, to avoid such an effect, it is necessary to form an extremely small quantity of silver iodide in the bath by the addition of a soluble iodide. If, say, a small quantity of cadmium iodide is added to the bath, the solution will at once turn milky; but on shaking it will become clear again, provided that only an extremely small quantity of the silver iodide is formed. One grain will be sufficient for the 8 oz. of silver bath given above. This operation is spoken of as saturating with silver iodide. In practice, it is usually best to dissolve the silver in half the water, then to add the iodide, shake, add the remainder of the water, and filter, when the acid may be put in. If the solution is more than saturated, the plate will come out with sparkling particles of metallic silver; this may be overcome by adding barium nitrate 1 part to 50 parts.

APPARATUS REQUIRED FOR WET COLLODION PROCESS.

For experimental work no special apparatus is necessary, but as the plate has to be used in a wet state some provision must be made in the dark-slide to catch the drainings and to avoid spoiling the appearance of the woodwork. A piece of blotting-paper folded up, on which to rest the bottom of the plate, and another piece behind the plate, will suffice; but in slides specially made for the purpose it is usual to have a silver-plated gutter along the bottom. The camera should preferably be one with flat sides, as it may be more

easily freed from dust, the great difficulty of the process. Bellows body cameras are great harbourers of dust. In other respects the form and fittings of the camera may be as usual, and must be chosen with a view to the work in hand rather than the process.

SILVER BATH AND DIPPER.

An upright silver bath of the shape shown in Fig. 150 will be necessary, and a dipper of the form of either Fig. 151 or Fig. 152. The former is made of ebonite, and may be purchased very cheap, while the latter is a home-made substitute consisting of a strip of glass of the shape

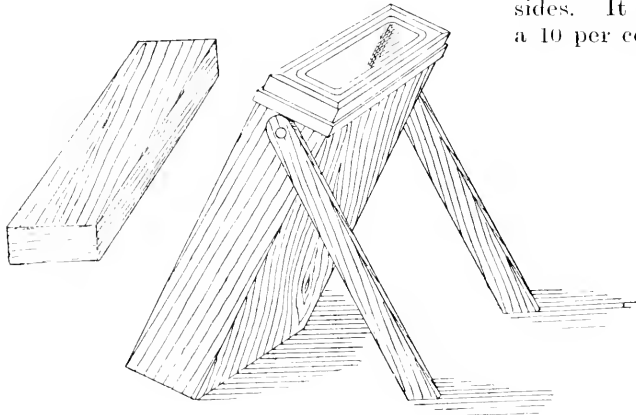

Fig. 150.—UPRIGHT SILVER BATH AND COVER.

shown, cemented to which is a narrow strip to form a rest for the plate. This may be attached with a little seccotine. Another kind of dipper, perhaps superior to the others, is shown by Fig. 153; this is made of silver wire. In dark-slides specially made, rests of silver wire are provided instead of the usual rebate.

COLLODION BOTTLES.

These bottles are made in the form illustrated by Figs. 154 to 156, so as to present as little area as possible to the air when the stopper is removed, as well as for convenience in pouring. Fig. 155, known as the cometless pattern, is the better of the two, although slightly more expensive. Fig. 156 is a combined bottle

and filter. In addition to the above, some suitable glass will be required. On the whole, good sheet glass carefully selected so as to be free from bubbles, scratches, and other defects will answer as well as anything for small sizes. For important work in large sizes, either flatted crown or patent plate should be used, the former for preference.

CLEANING THE PLATES.

The first operation is that of making the glass chemically clean. For this purpose, after cutting the desired size, the glass should be placed in a solution of caustic soda or potash for a few moments, and then well rinsed under the tap on both sides. It is then placed for an hour in a 10 per cent. solution of nitric acid and



Fig. 151.—EBONITE DIPPER.

well washed. An upright porcelain trough as used for fixing is most convenient, and a number of glasses may be done together. The glass is then well rubbed with a creamy solution of Tripoli powder, and polished with a dry cloth on both sides. This treatment ensures a good basis to work upon, and if not absolutely necessary in all circumstances, may prevent many troubles.

ALTERNATIVE METHOD OF CLEANING.

Instead of the method just described, a cleaning solution made as follows may be employed: Potassium bichromate, 1 oz.; sulphuric acid, 1 dram; and water, 10 oz. This is a useful cleaning solution for general purposes. It may be used repeatedly,

and should be kept in a bottle ready for use. It is poured out and swilled around the vessel or plate to be cleaned, and then returned to the bottle. After treatment the plate should be well rinsed with clean water. As the plates are cleaned they

A small camel-hair brush, to the side of which a wooden match has been tied, is drawn quickly along each edge of the nega-

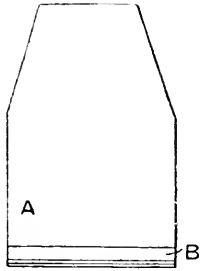

Fig. 152.—HOME-MADE DIPPER.



Fig. 154.—PLAIN COLLODION BOTTLE.



Fig. 155.—COMETLESS COLLODION BOTTLE.



Fig. 156.—COMBINED BOTTLE AND FILTER.

should be stored in a grooved box, as shown in Fig. 157, ready for use.

EDGING THE PLATE.

In order to prevent the collodion film "frilling" off or leaving the glass support, it is best first to edge the plate with rubber solution. For early experimental work the ordinary rubber solution as used for

tive, keeping the match firmly against the side of the plate. This puts a narrow edging of rubber solution of an even width along the margin.

EXPOSING WET PLATES.

The next operation is that of covering the plate evenly with a film of collodion;

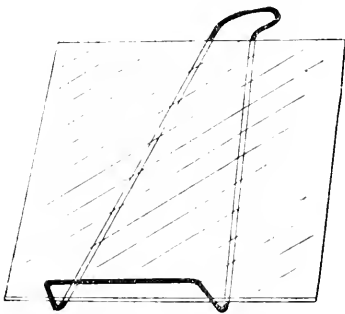

Fig. 153.—SILVER WIRE DIPPER.

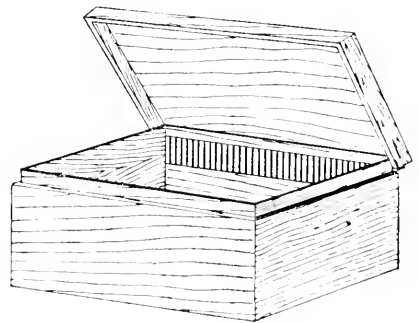

Fig. 157.—LIGHT-TIGHT GROOVED PLATE BOX.

mending tyres may be used, but it is more satisfactory to use a 1 per cent. solution of pure rubber in benzole. This should be applied to the plate in the same way as the opaque varnish is applied in safe-edging a negative to be used for carbon printing.

but as from this point the manipulations must go on almost without a break up to the completion of the negative, the operator should see that he has everything ready for use which may be required for sensitising, developing, fixing, and wash-

ing. He should also have fixed upon some subject for exposure. The most convenient way of exposing wet plates is through the camera, but as an introductory experiment the making of a "contact" transparency may be tried. Absolute contact is, of course, impossible, for as the one film is wet it would stick to and injure the other. By working, however, with a small light, say a candle-flame or acetylene bicycle lamp, a definite shadow is thrown which will give a fairly sharp image, even if the receiving surface is moved a little further away. Fasten a strip of stout paper across each corner of a negative with gum, and the collodion plate will then rest against these without doing harm. Prepared thus, the negative may be exposed in the printing-frame in the dark-room as described later for bromide printing.

COATING THE PLATE WITH COLLODION.

These matters settled, the collodionising of the plate may be proceeded with. A pool is poured in the centre of the plate about one-third its area, and flowed first to the top right-hand corner, then to the top left, then to the bottom left, and finally to the bottom right, whence the excess should be poured gently into the bottle. Do not allow the edge of the plate to touch the bottle if it can be avoided. Give the plate a gentle motion from side to side as the collodion is poured off. If the edge is allowed to grind on the side of the bottle, it will merely fill the solution with fine particles of glass. Directly the plate ceases to drip, replace the stopper in the collodion bottle and stand it by to set. On no account allow the collodion to run back on itself, or streaks and marks in the negative will be the result. In other respects, the coating is carried out in the same way as described on p. 69. A little practice in accordance with these instructions is advisable before commencing to coat with collodion. In coating small sizes, the plate may be supported on the tips of the fingers of the left hand, and held in position by the ball of the thumb, as shown in Fig. 159 (p. 81). When coated, the plate should be stood aside for the film to set. Setting will take a little longer in cold weather

than in the summer, and may usually be determined by a dulness spreading over the film. If in doubt, the corner from which the plate was drained may be touched very gently with the finger: if it shows no sign of tackiness, it may be taken to have set. It is then ready for immersion in the sensitising bath.

IMMERSING THE PLATE.

As soon as the collodion has set, the plate is placed on the dipper and gently lowered with one continuous sweep into the silver bath. Stoppages in immersing the plate, if of any appreciable duration, are liable to cause marks. The silver bath is supposed to have been poured into the upright bath already referred to. All the operations up to this point may be carried out in broad daylight without fear of damage, but after this a dull orange light only is permissible. Wet plates vary considerably in rapidity, and at the best they are much slower than an ordinary dry plate. It may be borne in mind that the silver iodide is not formed in the instant of immersion, and sensitising may therefore be commenced in white light without harm being done. When the plate has been immersed an instant, it is advisable to move it up and down in the bath until all greasiness has disappeared; in this way the ether is swilled off the surface, and an even sensitising action insured. If using a flat porcelain dish, the same result may be secured by rocking. The plate should remain in the bath for about three minutes. The exact time is governed by (*a*) the temperature and (*b*) the sensitive salt to be formed. The higher the temperature, the shorter the immersion. In summer, only two-thirds of that required in winter will be necessary. If the iodide only is to be formed, slightly over two minutes will suffice at ordinary temperature; but in winter a little over three minutes may have to be given, unless precautions are taken to keep the bath at an even temperature of 60° F. When the bromide has to be formed, the operation takes longer, six minutes being necessary in extreme cases; and greater care is required, as the plate will be more sensitive.

EXPOSURE OF THE PLATE.

The plate must now be very slowly withdrawn from the bath and stood up to drain on clean white blotting-paper. The excess is then taken from the back of the plate by wiping over with a piece of blotting-paper, and the plate may be laid on the silver wires in the carrier ready for exposure. When the exposure is to be a long one, or when the plate is likely to remain some time before exposure for a special effect, a sheet of wet blotting-paper should be laid at the back of the plate to keep the air moist. The duration of exposure may be found as described, first making a graduation test in order to compare the relative rapidity of the plate. Plates prepared with the simple iodide will possibly require fifteen to twenty times the exposure of an ordinary plate, but those prepared with bromo-iodide or bromide will be proportionately quicker. One advantage of the wet plate, as with all slow plates, is the great latitude of exposure allowable, considerable increase being possible without any serious result. An important warning may here be given to those accustomed to handle dry plates. On no account must the film be touched, as it is extremely tender; a strong flow of water even is sufficient to destroy it completely. The appearance of a wet plate after development and fixing is similar to that of a dry plate which has been bleached in mercury, being a brownish colour by transmitted light and a cream colour by reflected light.

PURIFYING THE BATH.

In addition to the information already given on this subject, some instructions may be laid down on purifying the bath from special impurities, such as ether, alcohol, etc. If the bath is gently warmed, the ether, owing to its volatility, will be easily driven off. It is not necessary to heat the bath to any considerable extent for this purpose, but the alcohol will need a much higher temperature, so that it is usual to drive off both together by pouring the bath into a large beaker and boiling up for a time. This heating should continue until rather more than a half has been

evaporated, when the strength of the solution is taken with the argentometer and sufficient distilled water added. Instead of using heat, the bath may be evaporated by exposure to the air; but the operation will, of course, take proportionately longer.

WET-COLLODION DEVELOPERS.

The developers employed in wet-plate photography are numerous, and, unlike those used in the modern dry-plate method, they do not require an accelerator, but work in an acid state. They consist merely of a reducer, a restrainer, and a medium for holding both, the water. To this, for convenience in making the solutions flow evenly, is added a small quantity of alcohol. As this subject will be dealt with in a later section, it is not necessary to pursue the subject further. The following is a typical formula: Reducer, ferrous sulphate, $\frac{1}{4}$ oz.; restrainer, glacial acetic acid, 1 dram; diffuser, alcohol, in sufficient quantity; medium, water, 5 oz. Pyrogallic acid and the double sulphate of iron and ammonia may also be employed as the reducing agent. Development may be carried out in a dish, but more frequently the plate is held in the hand. The iron developer may be used repeatedly, but it is not advisable. For fixing, either hypo. or potassium cyanide may be employed. The proper strength for the hypo. is 1 to 6; if the cyanide is used, it should be 1 to 16. In many instances wet plates are intensified, a favourite intensifier being pyro. and silver. The method of intensification, and the necessary formula are given in the section dealing with that subject.

DEFECTS OF THE WET COLLODION PROCESS.

Leaving out those defects which are common to all photographic processes, such as light fog, etc., there are still several which are of special interest. For instance, too much or too little iodide in the collodion is apt to cause insensitive spots or pin-holes. Dust, which may be in the air, the collodion, or the silver bath, is liable to cause black spots. Insoluble particles of gun-cotton in the collodion cause "comets," a sort of black spot with a tail

to it. Streaky marks may be caused by the collodion or silver solution flowing back over the plate, the collodion containing too much alcohol or an unsuitable sample of pyroxyline. Too much care cannot be taken to avoid dust and grit.

THE FERROTYPED PROCESS.

The ferrotype process, in careful hands, is capable of producing results which, if not comparable with modern processes, are at least vastly superior to the results obtained generally with the process by itinerant photographers, for artistic skill

alike. Failing this, a repeating back may be used, but even this necessitates separate sittings.

SUITABLE FORM OF CAMERA.

An old wet-plate camera and portrait lens may be used for the process. These often may be had of a second-hand dealer for a very small sum. This form of camera has two advantages: if of box form, it can be more easily freed from dust, and the slide will be provided with silver wires for the plate to rest upon, and a gutter at the bottom to receive drippings from the plate.

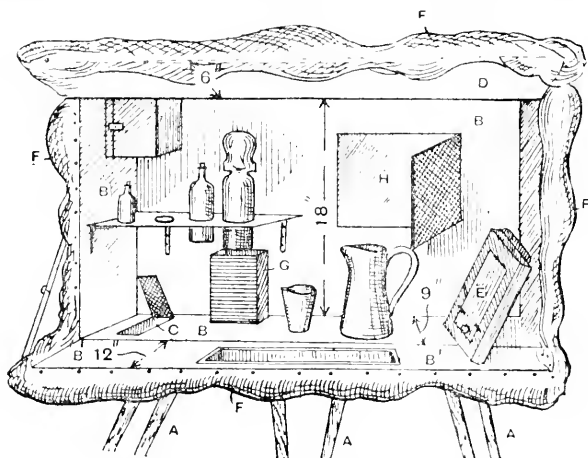

Fig. 158.—DARK TENT FOR FERROTYPED WORK.

in posing, lighting, and composition will make itself felt in either. Ferrotypes are collodion positives taken upon a dark enamelled iron plate by a wet or dry process, usually the former. The picture appears reversed as regards left and right. Those formerly made by a similar process upon glass plates, and viewed from the glass side, do not appear so reversed; they are called glass positives, and not ferrotypes, and are backed with black varnish. A ferrotype is a positive and not a negative process—that is to say, one in which white will be rendered as white in the first result. Being so, it is necessary, when many copies are required, to have the camera fitted at the front with a battery of lenses, so that the desired number may be taken with one exposure and exactly

An ordinary camera may be used, but a wad of blotting-paper must be put in the slide for the plate to drain upon. If a box camera is used, it must be placed upon a substantial tripod.

THE DARK TENT.

A dark tent is also required if the work is to be done out of doors and at various places, as is generally the case. The method of fitting up a dark tent is shown by Fig. 158, in which A is the tripod, B is the carrying case, with one side B folded down to form a table; C is the silver bath, D the remaining part of the case, folded up; E the dark slide, G the fixing bath, and F a bag glued (or otherwise fastened to make a light-tight joint) around the extreme of the inside edges. This bag may

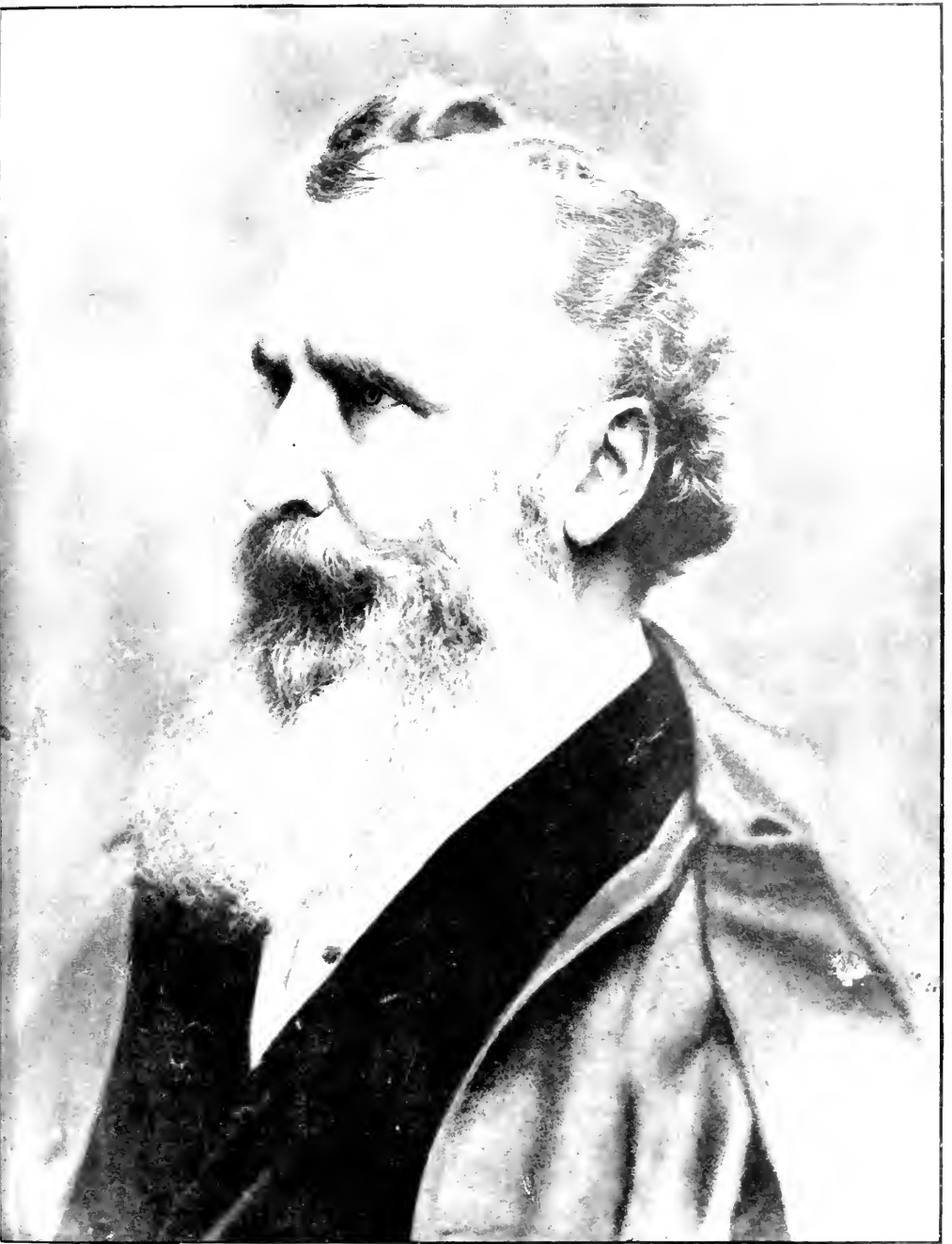

UNTOUCHED PHOTOGRAPH.

be made of two thicknesses of rubber-lined cloth. A window of ruby fabric is fitted at H. The bag is rolled back when not required, but, when in use, falls down around the operator, and may be reeved up round the waist.

MATERIALS REQUIRED.

Other requisites are a 2-oz. bottle of Mawson's iodised collodion, 1 oz. of nitrate of silver, $\frac{1}{4}$ oz. of potassium iodide, 1 oz. each of nitric and acetic acids, one pennyworth of protosulphate of iron, 1 oz. of alcohol, specific gravity '805, 1 oz. of caustic potash, 1 oz. of cyanide of potassium, a few dozen ferrotype plates, and two dippers, as shown by Fig. 151. Dippers are usually of ebonite, but may be made by cementing along the bottom of a long strip A (Fig. 152), a small strip of glass B. An upright glass bath for silver, a 4-oz. tumbler, and 5 oz. of crystal varnish also are required.

MAKING THE SILVER BATH.

The silver bath is first made up very carefully. In 16 oz. of distilled water dissolve 1 gr. of potassium iodide, and add 1 oz. of nitrate of silver. Thoroughly mix this solution by shaking, and allow to stand for some hours in sunlight. If a precipitate falls, decant the top. Then add one or two drops of nitric acid, sufficient to make the bath turn litmus paper faintly red. If the bath is too acid, marks on the film will be caused; if too little acid is used, the picture will be flat and of a dirty grey appearance. In the first case a little neutral silver solution must be mixed up and added. The remedy in the other case is obvious. The silver bath, being made up, is poured into the glass bath, and kept covered.

SUITABLE DEVELOPERS.

The developer is next made up. Add 1 oz. of acetic acid (glacial) to 16 oz. of water, and dissolve in this 1 oz. of protosulphate of iron. Then add 1 oz. of alcohol to make the developer run easily. The fixing bath is easily made by dissolving 5 scruples of potassium cyanide in 4 oz. of water. This solution, being very poison-

ous, is best kept in an upright bath, like the silver. Another suitable developer is iron protosulphate $1\frac{1}{2}$ oz., nitrate of baryta 1 oz., nitric acid 40 drops, water 20 fluid oz. To this, although not indispensable, about 1 fluid oz. of alcohol may be added to make the developer flow properly over the surface of the exposed plate.

HOME-MADE COLLODION.

Home-made collodion is preferred by many experienced workers, but it is not advisable for the beginner to make his own. However, a reliable formula for

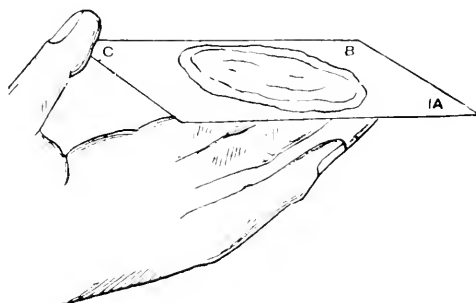

Fig. 159.—POURING ON POOL OF COLLODION.

collodion is here given: Ether and alcohol 20 fluid oz. each, gum-cotton 200 grains, bromide of cadmium 100 grains, iodide of cadmium 80 grains, iodide of ammonium 120 grains. In making up, the alcohol is first added to the gum-cotton, and then the ether. When all the gum-cotton is dissolved the collodion should be filtered. The collodion is bromo-iodised by simply adding the cadmium bromide and the two iodides ground and mixed. The ether used should have a specific gravity of about '72, while that of the alcohol should be about '8.

COATING THE PLATE.

The actual work of preparing a wet collodion plate may now be begun. Take one of the enamelled iron plates, and, having cleaned it, rest it upon the tips of the fingers as shown in Fig. 159, and pour in the centre a pool of collodion about half the size of the plate. Now very slowly and slightly tilt the plate in the direction of the corner A, to which the collodion will run. Just before it reaches the edge, tilt

towards B (still very gently and smoothly). In the same way run the collodion to C, almost touching the thumb, and pour off into another bottle. When this bottle gets full the collodion may be filtered back into the first bottle again. After a time it may become thick by evaporation of the ether and alcohol, in which case 2 parts of the first to 1 of the second may be added until the desired consistency results. It may be mentioned that an excess of ether causes the collodion to set too rapidly, whilst too much alcohol makes it too glutinous. As soon as the collodion has nearly all run off, rock gently (to prevent streaks) from edge to edge, and not back to front. By this time a general dulness will have spread over the film, showing the collodion has "set." When undecided, touch the bottom corner, and if no longer tacky or sticky, it is ready. Collodion takes longer to set in cold than in hot weather.



Fig. 160.—DARK-SLIDE WIRES.

SENSITISING THE FILM.

Place the film upon the dipper, and slide with a gentle and continuous motion down into the silver bath; a stop or hesitation will cause a line across the plate. Whilst the plate is being "excited," prepare the slide, wiping it out, if necessary, as dust is fatal. It is not necessary to coat the plates and dip in the silver bath in the dark, as the iodide of silver is not formed immediately upon immersion; but if these processes are carried on in the open, the bath must be covered with a light-tight cover the instant the plate is put in. When about a minute has elapsed, draw out gently in the dark and see if greasiness has gone (in cold weather about double this time); if it has not, markings may be expected. When the plate appears quite even, dip and withdraw a few times slowly. Any dust on the top of the bath should be skimmed off with a strip of perfectly clean blotting-paper. Then blot off the back and allow to drain for half a minute.

EXPOSURE, DEVELOPMENT, FIXING, ETC.

Place the plate on the wires (Fig. 160) of the dark slide and insert the same very gently in the camera, drawing out the slide shutter with great care to avoid dust, and after exposure close in the same way; return to the tent and deposit it, still in an upright position. Take sufficient developing solution in the glass, lower the bag, hold the plate as in coating, and pour the solution over, giving a gentle rock to keep it flowing slowly to and fro on the plate. This requires a little practice. Do not pour on with a splash. Have underneath the plate a bottle with funnel containing a little cotton-wool. The developer running off the plate is thus filtered ready for use in cases of over-exposure. It is necessary that the exposure be very correct; this is a matter that can only be learnt by experience, as development cannot be controlled as in dry plate work. Directly the image is fully out (if it is stopped too soon it will be too black; if allowed to remain too long it will be weak, flat, and foggy), swill and transfer to fixing bath, using another dipper. When the shadows appear quite clear, the ferrotype should be well washed for a minute or longer. If this is done by pouring over it water out of a jug, do not pour too rapidly and heavily. An over-developed ferrotype, or one weak and flat, may be improved by adding a drop or two of iodine to the fixing bath. A little of the latter may be taken up in another measure to which this has been added and applied as in developing. After final washing the plate may be dried slowly, face upwards, over a small lamp and varnished, the varnish being applied by flowing over the plate as usual. Ferrotypes can be controlled but little in development, and it is usually better to take another if greatly in error. Transparent varnish for ferrotypes is best when bought ready-made; it is a solution of seed lac in methylated alcohol.

DRY-COLLODION PLATES.

What are known as collodion plates are plates of either glass or metal coated with emulsion in which the vehicle used for the

sensitive salts is collodion instead of gelatine. Collodio-bromide emulsion can be purchased if desired, or it may be made as follows. The chemicals used are silver nitrate, zinc bromide, alcohol, ether, and pyroxyline, and the precautions already referred to must be taken as regards purity. The alcohol must be the pure spirit, not mineralised. The ether may be methylated, but should be of the purified kind, with a specific gravity of '825.

PREPARING THE EMULSION.

All the apparatus required is a 7 in. by 5 in. glass, or porcelain dish, a few test tubes, a beaker, and a 20-oz. bottle. Weigh out 100 grs. of pyroxyline, and add 4 oz. of alcohol and 4 oz. of ether, and shake, when the cotton will be seen to be changed to a glutinous transparent mass. This solution should be stood aside for a time, and in the meanwhile 125 grs. of zinc bromide may be dissolved in $\frac{1}{2}$ oz. of alcohol in a test tube. In a boiling tube dissolve 160 grs. of silver nitrate in 160 minims of distilled water, using sufficient heat, and add 300 minims of alcohol. This should be kept warm until mixed with collodion. Now take the plain collodion, and add the silver solution to it in parts, introducing about 30 minims at a time and shaking vigorously between each addition. The zinc bromide solution may now be added by one of the methods already suggested, and thoroughly mixed. The emulsion can then be poured out into the dish and washed as usual, or used without washing; it must be kept in an opaque or deep-ruby bottle.

FINISHING THE PLATES.

The glass may be cleaned with alcohol, and after polishing with a clean chamois leather, is edged with a solution of rubber and coated as before described. When coated, the plates may be placed in a rack with divisions about 1 in. apart to dry. It is also possible to dry them in an oven—a hot-air or hot-water oven, as used for chemical experiments, is preferable (see Fig. 161); but the kitchen oven may be used, taking care that the plate is well protected from light the whole time.

Plates so prepared may be used when dry, or kept for a time, although they lose sensitiveness by too long keeping. The method of developing is dealt with elsewhere. The plates are used for lantern-slide making, for which they are popular on account of their fine grain and ease of working; they are also used in ferrotype photography.

ALBUMEN PLATES.

The plate which gives the finest grain of any known process is one produced with

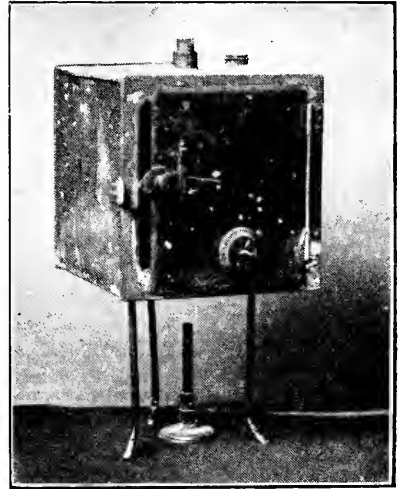

Fig. 161.—DRYING OVEN.

albumen as the vehicle. The glass plate is coated with albumen containing iodide, and is then sensitised by immersion in the silver bath. Such plates are exceedingly slow. The process is now of more than historical interest, as it is the one used in the Lippman process of natural colour photography, the ordinary plate having a grain too coarse to give the necessary laminae of silver.

NEGATIVE PAPERS.

Since film photography has become so popular, and as it possesses such immense advantages in every way, except perhaps that of cheapness, negative papers have fallen out of use. A few years ago there

was an attempt to revive their use, but the results are never very satisfactory except for very large work. They consist of paper coated with emulsion of the usual rapidity for plates, the paper either before or after being parchmented, waxed, or otherwise rendered translucent to get rid of the grain as far as possible. Even ordinary bromide paper may be used in this

way for making enlarged negatives, except that the thinness of the coating seldom allows sufficient density of deposit in the high lights. After fixing, washing, and drying, the paper is rubbed over on the back with wax, and then ironed between sheets of blotting-paper until the effect is quite even. Oil may be used instead of wax for the same purpose.

EXPOSURE OF THE PHOTOGRAPHIC PLATE.

METHOD OF EXPOSURE.

POSSIBLY no part of photographic work presents greater difficulties to the novice than the estimation of exposure, whilst the more experienced worker striving for perfection can hardly devote too much time to acquiring a complete knowledge of the subject. Every exposure should be definite—that is to say, one should know precisely in every detail what to do and why it is done, so that the operation may be repeated at will with the certainty of securing the best result. A large number of the exposures made, not only by amateurs but by those engaged in the work professionally, are of such a haphazard nature that the operator can seldom say with certainty what the result will be until the picture is developed. At the same time, there are so many factors to take into consideration that it would be impossible to make rules to meet every contingency. What is required is a basis on which to work, and on which a system can be built up, enabling the operator to form a method of his own.

FALLACIES REGARDING EXPOSURES.

First among these is (*a*) the impression that different lenses vary in rapidity, although similar stops are used. The amount of light reaching the plate depends upon the size of the hole by which it is admitted and the distance over which it has to travel; therefore, when the diameter of the stop bears the same proportion to the focal length, the intensity of the light will, for all practical purposes, be the same. Theoretically there are certain other considerations, such as the number of reflecting surfaces, but these for the present may

be ignored. (*b*) It is frequently supposed that if a whole-plate lens be used to form a half-plate picture, less exposure will be required. A moment's consideration of the facts proving (*a*) will show this also to be wrong, as here again the amount of light received by the plate is represented by the proportion the stop bears to the focal extension, it being an unimportant point whether the whole of the picture formed by the lens is received on the plate or only a portion of it. At the same time, where the field given by the lens covers a much larger area than the plate can accommodate, the remainder is distributed over the interior of the camera, and may, if reflected back, influence exposure by the introduction of fog. (*c*) Again, it is often imagined that the position of the camera in the sun or shade directly affects the exposure. The light used to form the image on the photographic plate is that which is reflected from the object being photographed; but the amount of light reaching the camera may differ considerably from the amount reaching the object and reflected to the camera, and therefore cannot be taken as a guide for exposure.

FACTORS AFFECTING EXPOSURE.

Objects require more or less exposure according to the colour and the amount of light reflected to the lens. Different lights affect the plate to a different extent, the red least and the blue most, therefore the exposure will have to be altered to suit the varying proportions of these rays. As already pointed out, white light is a mixture of several colours, and the colour of

objects is due to their power of absorbing some of these rays and reflecting others. In photography, as in other methods of picture-making, the aim is to represent the contrasts of light and shade, or values, of an object: so that it would be erroneous to assume that the correct exposure is directly proportional to the light intensities reflected from the object. It is a well-known fact that less exposure is required when there are light clouds facing the sun, as the light being reflected will lead to its more even diffusion. The exposure required is

go beyond stating the proportionate speed between their own varieties.

INTENSITY OF LIGHT.

As already stated, the general factor of intensity is that of the lens aperture. It may be explained that every lens has a focal length—that is, it has a point of minimum distance at which an image can be produced. According to the qualities of the lens, so is it possible to use a stop of certain proportions, the relation which the diameter of this stop bears to the focal length being referred to as its intensity ratio. Suppose, for example, two rooms are compared (Fig. 162), one 20 ft. long, A, and the other 10 ft. long, B, and each is lighted by one window only, 1 ft. square, C. It will be seen that the amount of light received on the wall at the far end of the room will not be the same in each case; as in the larger room, A, the light rays represented by lines R R have further to travel and have to spread over a larger area than in B. In fact it will be noted that in the case of B they are covering a space only one fourth the size, and therefore this will be four times as brightly illuminated. So that if their relative light intensities were measured, the one would be found to be only a quarter that of the other. Most lenses are now marked with numbers, which express the fraction their diameter is of the focal length; they usually range from $f8$ to $f64$, $f8$ being $\frac{1}{8}$ th of the focus, and $f64$ being $\frac{1}{64}$ th of the focus. The proportionate exposure required with these stops will be inversely as the square of the diameter, due, of course, to the difference in the area of the opening. For example, the difference of exposure required with $f8$ and $f16$ will be as the square of 8 is to the square of 16, or as 1 is to 4.

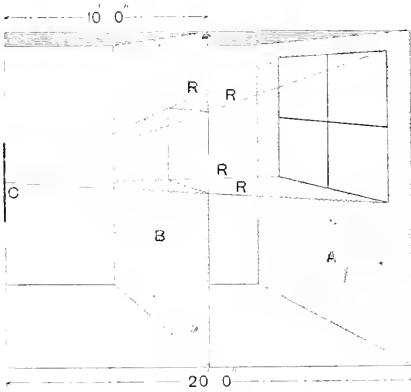

Fig. 162.—VARYING INTENSITY OF LIGHT.

also less after a shower, for the air has been cleared of much of the suspended matter that tends to obstruct those light rays, which are specially active.

SENSITIVENESS OF PLATE.

The sensitiveness of the silver bromide, or the readiness with which it is split up and finally reduced to a metallic state, thus forming the darkened image, varies chiefly according to the method by which it is prepared. Even plates prepared in the same manner and by the same formula vary in sensitiveness, while plates which are roughly described by their makers as slow, ordinary, medium, rapid, and special rapid, may vary in speed from time to time. As a general rule, however, with plates of a reliable make the difference is not serious. All makers now adopt some system of speed marking, although they do not all

USING STOPS IN EXPOSURES.

A simple though somewhat crude method of determining the relative exposure required with different stops, which may be made use of in cases of emergency, is to measure the diameter of each, square the fraction, and invert, when the proportions will be directly in proportion to the numbers, and not inversely as in the former

case. For example, if one stop measures $\frac{1}{2}$ in. and another $\frac{1}{4}$ in., the proportion will be as 2^2 is to 4^2 , or as 1 is to 4. This, of course, only refers to stops from the same lens. Another system of stop marking, known as the U.S. or uniform system, was introduced some years ago by the Royal Photographic Society. In this $f4$ is taken as the unit, and is called U.S. No. 1; $f5.6$, No. 2; $f8$, No. 4; $f11.31$, No. 8; $f16$, No. 16; $f22.62$, No. 32; $f32$, No. 64. The principle of this system of marking is that the proportionate intensities of the various stops may thus be indicated directly from their marking. Thus stop U.S. No. 1 will require $\frac{1}{64}$ th the exposure of stop U.S. No. 64.

VARIATIONS IN INTENSITY OF LIGHT.

The intensity of light varies from month to month, in accordance with the altitude of the sun. The following table, compiled by Prof. A. Scott, shows the proportionate variation in the intensity of light at different times of the year for countries in Lat. 53° :—

TABLE I.

Hour of Day	June	May or July	April or Aug.	Mar. or Sept.	Feb. or Oct.	Jan. or Nov.	Dec.
A.M. 12	1	1	$1\frac{1}{2}$	$1\frac{1}{2}$	2	$3\frac{1}{2}$	4
11 or 1	1	1	$1\frac{1}{2}$	$1\frac{1}{2}$	$2\frac{1}{2}$	4	5
10 " 2	1	1	$1\frac{1}{4}$	$1\frac{3}{4}$	3	5	6
9 " 3	1	$1\frac{1}{4}$	$1\frac{1}{2}$	$2\frac{1}{4}$	4	12	16
8 " 4	$1\frac{1}{2}$	$1\frac{1}{2}$	2	3	10		
7 " 5	2	$2\frac{1}{2}$	3	6			
6 " 6	$2\frac{1}{2}$	3	6				
5 " 7	5	6					
4 " 8	12						

The figures represent the proportionate differences in the time of exposure from month to month, other factors remaining the same. In a similar way the light varies from hour to hour, the proportion of which will also be seen on referring to this table. These proportions do not hold good in all latitudes, as will presently be explained, but are intended for countries about latitude 53.38 , such as the British Isles, North Germany, Canada, and the Falkland Islands. Tables calculated for other latitudes are given on pp. 88 and 89.

COLOURS OF RAYS REACHING PLATE.

It has already been mentioned that the colour of objects is due to their property of absorption. Now absorption occurs both with reflected and transmitted light, so that in the passage of rays from their source some of them may be absorbed when striking the object and others in passing through the lens. In the first case the absorption has taken place in the object from which they are reflected, and in the second during their passage through the lens. To prove this, one may look at, say, a brightly coloured blue object in a red light, and it will appear black, whilst a yellow object held up to a lamp of the same light will appear practically colourless. If, therefore, the lens or anything through which the rays have to travel should have the property of absorbing certain rays, the intensity of the light must be greatly altered, particularly if it should absorb the blue and violet rays, and pass only such rays as orange or red, which have little or no action on the photographic plate.

ATMOSPHERIC INFLUENCES.

Moisture in the air also exercises this property, and necessitates an increase of exposure. About one quarter of the light which reaches us from the sun consists of ultra violet rays, which, though immensely active on the photographic plate, are quite invisible to the human eye. Such rays are easily absorbed when passing through a glass faintly tinted yellow, or may be obstructed by the moisture suspended in the air. This explains why exposure may be shortened at high elevations, because there is less intervening atmosphere, and it is more rarefied. In the early morning or late evening, on the other hand, the light travels through a greater depth of atmosphere, and the exposure is proportionately lengthened. At such times plates prepared so as to be specially sensitive to the yellow rays are an advantage. These plates are called orthochromatic, isochromatic, and sometimes chromatic, and will be referred to later. The method of preparing them is explained in the preceding section (see p. 72).

LIGHT INTENSITIES FOR VARIOUS LATITUDES.

In this connection it may be noted how the exposure varies in different latitudes. For example, the proportionate exposure at noon in latitudes 30° and 60° are as 12 is to 16. The following tables show the proportionate light intensities for various latitudes. They are, of course, calculated for average conditions of weather and atmosphere, and do not take account of anything exceptional which may occur. Except in unusual circumstances, however, they will be found remarkably accurate.

TABLE II.—NEAR SOUTH LATITUDE 23°. NORTH AUSTRALIA, MADAGASCAR, AND SOUTHERN BRAZIL.

A.M.	P.M.	Dec.	Nov. or Jan.	Oct. or Feb.	Sept. or Mar.	Aug. or April	July or May	June
12		$\frac{3}{4}$	$\frac{3}{4}$	$\frac{3}{4}$	1	1	1	$1\frac{1}{4}$
11 or 1		1	1	1	1	1	$1\frac{1}{4}$	$1\frac{1}{2}$
10 .. 2		1	1	1	$1\frac{1}{4}$	$1\frac{1}{4}$	$1\frac{1}{2}$	$1\frac{3}{4}$
9 .. 3		$1\frac{1}{4}$	$1\frac{1}{4}$	$1\frac{1}{4}$	$1\frac{1}{2}$	$1\frac{1}{2}$	2	3
8 .. 4		$1\frac{1}{2}$	$1\frac{1}{2}$	$1\frac{1}{2}$	2	2	$2\frac{1}{4}$	3
7 .. 5		$2\frac{1}{4}$	$2\frac{1}{2}$	$2\frac{1}{2}$	$3\frac{1}{2}$	$3\frac{1}{2}$	6	15
6 .. 6		6	7	12				

TABLE III.—NEAR NORTH LATITUDE 23°. INDIA AND MEXICO.

A.M.	P.M.	June	May or July	April or Aug.	Mar. or Sept.	Feb. or Oct.	Jan. or Nov.	Dec.
12		$\frac{3}{4}$	$\frac{3}{4}$	$\frac{3}{4}$	1	1	1	$1\frac{1}{4}$
11 or 1		1	1	1	1	1	$1\frac{1}{4}$	$1\frac{1}{2}$
10 .. 2		1	1	1	$1\frac{1}{4}$	$1\frac{1}{4}$	$1\frac{1}{2}$	$1\frac{3}{4}$
9 .. 3		$1\frac{1}{4}$	$1\frac{1}{4}$	$1\frac{1}{4}$	$1\frac{1}{2}$	$1\frac{1}{2}$	2	3
8 .. 4		$1\frac{1}{2}$	$1\frac{1}{2}$	$1\frac{1}{2}$	2	2	$2\frac{1}{4}$	3
7 .. 5		$2\frac{1}{4}$	$2\frac{1}{2}$	$2\frac{1}{2}$	$3\frac{1}{2}$	4	6	15
6 .. 6		6	7	12				

TABLE IV.—NEAR SOUTH LATITUDE 30°. SOUTH AUSTRALIA, CAPE COLONY, ARGENTINE.

A.M.	P.M.	Dec.	Nov. or Jan.	Oct. or Feb.	Sept. or Mar.	Aug. or April	July or May	June
12		$\frac{3}{4}$	1	1	1	1	$1\frac{1}{4}$	$1\frac{1}{2}$
11 or 1		$\frac{3}{4}$	1	1	1	1	$1\frac{1}{4}$	$1\frac{1}{2}$
10 .. 2		1	1	1	1	$1\frac{1}{4}$	$1\frac{1}{4}$	2
9 .. 3		1	1	1	$1\frac{1}{4}$	$1\frac{1}{4}$	$1\frac{1}{2}$	$2\frac{1}{2}$
8 .. 4		$1\frac{1}{2}$	$1\frac{1}{2}$	$1\frac{1}{2}$	2	2	$2\frac{1}{4}$	3
7 .. 5		$2\frac{1}{4}$	$2\frac{1}{2}$	$2\frac{1}{2}$	$3\frac{1}{2}$	4	6	15
6 .. 6		6	8	14				

TABLE V.—NEAR NORTH LATITUDE 30°. CHINA, EGYPT, SOUTHERN STATES OF AMERICA.

A.M.	P.M.	June	May or July	April or Aug.	Mar. or Sept.	Feb. or Oct.	Jan. or Nov.	Dec.
12		$\frac{3}{4}$	1	1	1	1	$1\frac{1}{4}$	$1\frac{1}{2}$
11 or 1		1	1	1	1	1	$1\frac{1}{4}$	$1\frac{1}{2}$
10 .. 2		1	1	1	1	$1\frac{1}{4}$	$1\frac{1}{4}$	2
9 .. 3		1	1	$1\frac{1}{4}$	$1\frac{1}{4}$	$1\frac{1}{2}$	$1\frac{1}{2}$	$2\frac{1}{2}$
8 .. 4		$1\frac{1}{2}$	$1\frac{1}{2}$	$1\frac{1}{2}$	2	$2\frac{1}{4}$	3	5
7 .. 5		2	$2\frac{1}{2}$	$2\frac{1}{2}$	$3\frac{1}{2}$	6	9	
6 .. 6		6	8	14				

TABLE VI.—NEAR NORTH LATITUDE 40°. UNITED STATES, SPAIN, ITALY, JAPAN, ARMENIA.

A.M.	P.M.	June	May or July	April or Aug.	Mar. or Sept.	Feb. or Oct.	Jan. or Nov.	Dec.
12		1	1	1	1	$1\frac{1}{4}$	$1\frac{1}{2}$	2
11 or 1		1	1	1	1	$1\frac{1}{4}$	$1\frac{1}{4}$	2
10 .. 2		1	1	$1\frac{1}{4}$	$1\frac{1}{4}$	$1\frac{1}{2}$	$1\frac{3}{4}$	$2\frac{1}{2}$
9 .. 3		$1\frac{1}{4}$	$1\frac{1}{4}$	$1\frac{1}{4}$	$1\frac{1}{2}$	2	$2\frac{1}{2}$	$3\frac{1}{2}$
8 .. 4		$1\frac{1}{2}$	$1\frac{1}{2}$	$1\frac{1}{2}$	$2\frac{1}{4}$	$2\frac{1}{4}$	4	8
7 .. 5		2	$2\frac{1}{2}$	$2\frac{1}{2}$	4	7		
6 .. 6		$3\frac{1}{2}$	$3\frac{1}{2}$	$3\frac{1}{2}$	8			
5 .. 7		9	5	8				

TABLE VII.—NEAR SOUTH LATITUDE 40°. TASMANIA, MELBOURNE, NEW ZEALAND.

A.M.	P.M.	Dec.	Nov. or Jan.	Oct. or Feb.	Sept. or Mar.	Aug. or April	July or May	June
12		1	1	1	1	$1\frac{1}{4}$	$1\frac{1}{2}$	2
11 .. 1		1	1	$1\frac{1}{4}$	$1\frac{1}{4}$	$1\frac{1}{4}$	$1\frac{1}{4}$	2
10 .. 2		1	1	$1\frac{1}{4}$	$1\frac{1}{4}$	$1\frac{1}{2}$	$1\frac{3}{4}$	$2\frac{1}{2}$
9 .. 3		$1\frac{1}{4}$	$1\frac{1}{4}$	$1\frac{1}{4}$	$1\frac{1}{2}$	2	$2\frac{1}{2}$	$3\frac{1}{2}$
8 .. 4		$1\frac{1}{2}$	$1\frac{1}{2}$	$1\frac{1}{2}$	$2\frac{1}{4}$	$2\frac{1}{4}$	4	8
7 .. 5		2	$2\frac{1}{2}$	$2\frac{1}{2}$	4	7		
6 .. 6		$3\frac{1}{2}$	$3\frac{1}{2}$	$3\frac{1}{2}$	8			
5 .. 7		9	5	8				

TABLE VIII.—NEAR NORTH LATITUDE 60°. NORWAY.

A.M.	P.M.	June	May or July	April or Aug.	Mar. or Sept.	Feb. or Oct.	Jan. or Nov.	Dec.
12		1	$1\frac{1}{4}$	$1\frac{1}{4}$	$1\frac{1}{2}$	2	$2\frac{1}{4}$	$2\frac{1}{2}$
11 or 1		1	$1\frac{1}{4}$	$1\frac{1}{4}$	$1\frac{1}{2}$	2	$2\frac{1}{4}$	3
10 .. 2		$1\frac{1}{4}$	$1\frac{1}{4}$	$1\frac{1}{4}$	$1\frac{1}{2}$	$2\frac{1}{4}$	$2\frac{1}{4}$	4
9 .. 3		1	$1\frac{1}{4}$	$1\frac{1}{4}$	$1\frac{1}{2}$	$2\frac{1}{4}$	$2\frac{1}{4}$	7
8 .. 4		$1\frac{1}{2}$	$1\frac{1}{2}$	$1\frac{1}{2}$	$2\frac{1}{4}$	$3\frac{1}{2}$	6	
7 .. 5		2	$2\frac{1}{2}$	$2\frac{1}{2}$	$3\frac{1}{2}$	6		
6 .. 6		$2\frac{1}{2}$	$3\frac{1}{2}$	$3\frac{1}{2}$	8			
5 .. 7		4	7	7				
4 .. 8		7	7	7				

TABLE IX.—NEAR SOUTH LATITUDE 50°.

A.M.	P.M.	Dec.	Nov. or Jan.	Oct. or Feb.	Sept. or Mar.	Aug. or April	July or May	June
12		1	1	1½	1½	2	3½	4
11	or 1	1	1	1½	1½	2½	4	5
10	.. 2	1	1	1½	1½	3	5	6
9	.. 3	1	1½	1½	2	4	12	16
8	.. 4	1½	1½	2	3	10		
7	.. 5	2	2½	3	6			
6	.. 6	2½	3	6				

TABLE X.—NEAR SOUTH LATITUDE 60°.

A.M.	P.M.	Dec.	Nov. or Jan.	Oct. or Feb.	Sept. or Mar.	Aug. or April	July or May	June
12		1	1½	1½	1½	2½	2½	3½
11	or 1	1	1½	1½	1½	2½	3	8
10	.. 2	1½	1½	1½	2	2½	4	14
9	.. 3	1½	1½	1½	2½	3½	7	
8	.. 4	1½	1½	2½	3½	6		
7	.. 5	2	2½	3½	6			
6	.. 6	2½	3½	6				

TABLE XI.—NEAR THE EQUATOR. CENTRAL AFRICA, SUMATRA, BORNEO, NORTHERN BRAZIL, BRITISH GUYANA.

A.M.	P.M.	June or Dec.	Jan., May July, or Nov.	Feb., Apl. Aug., or Oct.	March or Sept.
12		1	1	½	½
11	or 1	1	1	1	1
10	.. 2	1	1	1	1
9	.. 3	1½	1½	1½	1½
8	.. 4	2	1½	1½	1½
7	.. 5	3½	3½	3	3

These tables—also the work of Prof. Scott—were compiled for use with the Ilford exposure meter, and are reproduced by kind permission of Ilford, Ltd. It will be noted that the tables for northern latitudes read June to December, whilst those for southern latitudes read December to June, December in these countries being the summer month.

LOSS OF ULTRA VIOLET RAYS.

Even when the glass of the lens is not tinted, there may be a decided loss of ultra violet rays. With glass (such as is used usually in making lenses) half an inch thickness permits only 55 per cent. of the ultra violet rays to pass. Seeing, however, that in this country the ultra violet rays are, as a rule, generally extracted before

the light reaches the lens, this is not a serious defect, but tends rather to uniformity.

DISTANCE FROM CAMERA.

At first thought it might appear that the farther the object is from the camera the greater the exposure required, but in actual practice the reverse is found to be the case, for the particles of matter suspended in the air cause the light to be independently reflected, and throw a luminous veil between the image and the camera, allowing a shorter exposure by the flattening influence it exerts upon the contrast. Again, an object at a considerable distance from the lens receives, generally speaking, the unobstructed light from the sun, and is therefore capable of reflecting a full quantity. It only needs to take an exposure including some near foreground objects and some distant objects, especially if the latter consists of sea and sky, to see how greatly the required exposures will differ. Roughly, about sixteen times the exposure will be required for the near view with shadows in the foreground as is required for sea or sky, supposing light, stop, plates, etc., are the same in each case.

INFLUENCE OF DISTANCE ON EXPOSURE.

This shows the necessity for a study of the influence of distance on exposure, a fact which is often treated with indifference, or ignored altogether, by the careless photographer. To understand it properly, and to make use of the information available in tables, a few experiments should be made. Figs. 163 to 165 show three distinctive types of photographs which may be roughly described. Fig. 163 is a near view with a dark foreground, Fig. 164 is an open landscape with a light foreground, and Fig. 165 is a distant view. If three such views are taken, giving each the same exposure, the difference will be extremely marked. At first sight it might appear that it would be possible to give the required exposure for any distance with exactness, and although this may generally be done with sufficient accuracy for all practical purposes, it must always be borne

in mind that each view will differ slightly, and, having new conditions, will require a modified exposure.

PROPORTIONAL LIGHT INTENSITIES.

It will be admitted that pictures exist only by contrast; therefore, the truest impression of any subject can be imparted only by a thorough study of its contrasts in

tensities which have to be registered by the photographic plate; and this is probably the most important principle concerning exposure. For example, suppose the plate to be capable of registering differences of the light's action varying from 1 to 32, and representing them by densities or deposits of metallic silver varying from 1 to 8—which is as much as the average



Fig. 163.—NEAR VIEW WITH DARK FOREGROUND.

correct proportion. When the contrasts are extreme—such, for example, as a view taken from the south coast pine forest looking seaward—the brilliancy of the contrast between the sea view and the shaded trees can only be suggested by extreme contrasts in the photograph. Such subjects are not suitable for photographic representation, as, except in very skilled hands and with a lot of dodging, the negative is almost sure to possess such extreme contrast as to appear “hard.” This emphasises the fact that it is the proportional and not the actual light in-

print is capable of showing—and suppose the subject to be such a one as described above. If a contrast of 1 to 32 is reduced to 1 to 8, then, roughly speaking, a contrast of 1 to 2 will be reduced to 1 to $1\frac{1}{2}$. And, further, if the varying intensities are extended from 1 to 64, then the contrasts of 1 and 2 are reduced to 1 to $1\frac{1}{8}$, and so on, until the contrast is practically nil. So that, supposing the varying intensities of the dark trees to be represented by numbers of value 1, 2, 3, and the contrasts of sea, sky, and cloud by 200, 201, 202, then it will be seen that if suffi-



Fig. 164.—OPEN LANDSCAPE WITH LIGHT FOREGROUND.

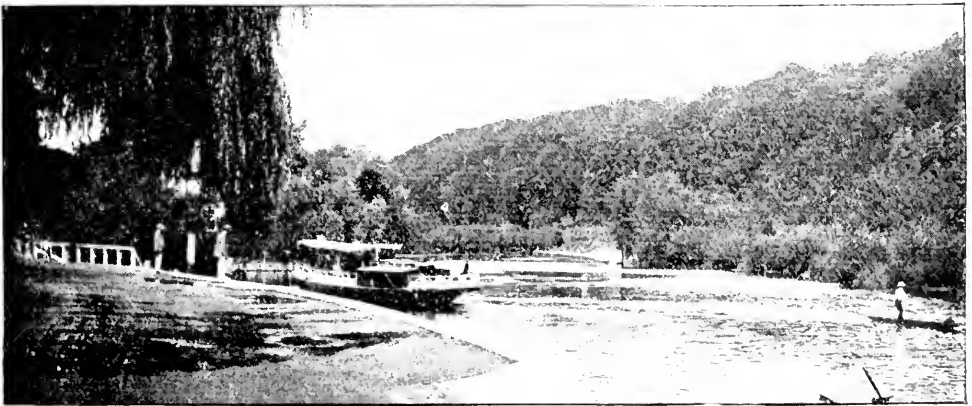

Fig. 165.—DISTANT VIEW.

cient exposure is given to obtain the contrasts of 1, 2, and 3, the contrasts 200, 201, and 202 must be completely buried; whilst, on the other hand, if 200, 201, and 202 are exposed for the contrasts, 1, 2, 3 must be

longer the exposure the greater the contrast; but directly that limit is reached, a reversing action takes place, and less photographic effect occurs where the light has acted most, the ultimate result being



Fig. 166.—TYPICAL PORTRAIT.

omitted, as these will have failed to impress the plate at all.

DEGREE OF CONTRAST.

The degree of contrast in the subject being photographed materially affects exposure. Within certain narrow limits, the

that the contrasts are reduced. The operator, therefore, has two powers available, both of diminishing and increasing the contrast. As the contrasts of nature are always far greater than can ever be represented upon a plain surface, all photographs taken direct from nature, such as

landscapes, etc., must reduce the contrast of the subject. On the other hand, where small portions only of some subjects are being photographed, or when copying another picture, it may be necessary to

MODIFICATIONS IN DEVELOPMENT.

Development and exposure are very closely connected, and it is quite possible to make a plate which has received normal



Fig. 167.—TYPICAL INTERIOR.

increase the contrast, and this may be done by varying the exposure. For example, an old, faded photograph may have contrasts of 1 to 4 only, and these may have to be extended to 1 to 8 to produce a brilliant image. In such a case, the exposure must be slightly less than normal, so that density may be produced from the white parts, or what should be the white parts, of the picture by prolonged development before the extreme shadows show any signs of veiling. Care must be taken, however, not to produce fog.

exposure appear either under or over exposed, according to the energy of the developer used upon it. Most developers allow considerable modification, that allowing least variation being the ferrous oxalate, and for this reason it is chosen for use in determining the rapidity of the emulsion. The effect of varying the developer is more pronounced when the plate has been over-exposed. A plate which has received under one quarter of the normal exposure will probably be useless, whereas one that has received fifty times the normal

exposure may with patience and care be made to give a satisfactory result.

EFFECTS OF FOG.

Perhaps the most important consideration in this connection is that of fog.

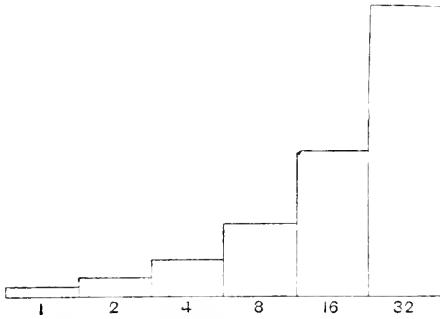

Fig. 168.—EVEN PROGRESSION OF DENSITIES.

There are two kinds of fog—(a) light fog, caused by the plate being impressed by some extraneous light or lights other than that passing through the lens or used to form the image; and (b) chemical fog, which results from the use of a more energetic reducing agent than the sensi-

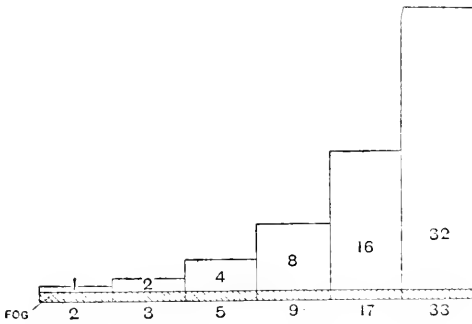

Fig. 169.—RESULT OF UNIFORM ADDITION OF FOG.

tive salts can stand, which induces a reduction of the silver, independent of any light impression, all over the plate equally. Such fog may also arise through errors in manufacture of the plate. Fog not only alters or destroys the gradations of the negative, but may be used to supply the necessary inertia for the production of an image. Generally speaking, fog is very detrimental, but in certain cases it may be

used to soften gradations and to strengthen detail, and as such is a valuable adjunct.

HOW FOG MAY BE UTILISED.

Suppose two plates have been exposed for precisely the same time, and are under-exposed impressions—that is to say, the lesser intensities of light have not acted long enough on the plate. Let one be developed free from fog, either chemical or light, and the shadows will all photograph alike, as the difference of deposit is too slight to be perceptible. Suppose now the other is allowed to receive a faint trace of white light, the result is that these densities are rendered apparent owing to the extra deposit added to the negative. Let the original gradations be represented

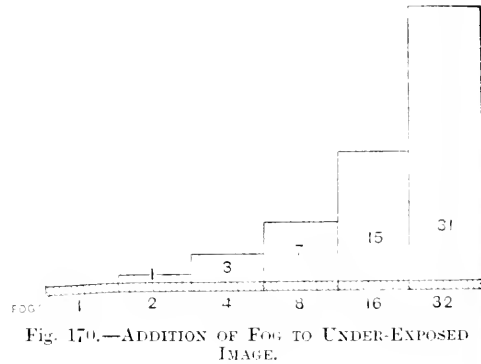

Fig. 170.—ADDITION OF FOG TO UNDER-EXPOSED IMAGE.

by the numbers 1, 2, 4, 8, 16, 32 (see Fig. 168) and a density equal to 1 be added to each, they then become 2, 3, 5, 9, 17, 33 (see Fig. 169), which shows that the total effect will be much more on the lesser densities than on the greater. The result is a softening or flattening of the picture. Whether such is or is not desirable will depend on the subject in hand and the taste of the operator. As a further illustration, let Fig. 170 represent one of the two under-exposed impressions of contrasts 1, 2, 4, 8, 16, 32, already referred to. This, if measured up, will be found to be 0, 1, 3, 7, 15, 31. If now a fog density equal to 1 is added, the contrasts or gradations required—namely, 1, 2, 4, 8, 16, 32—will be obtained, and the steps will now appear the same as Fig. 168. These must only be taken as imaginary, not as actual cases, the

figures being used merely as an illustration, as it was found to be impossible to reproduce the actual effect by half-tone printing. It is in such circumstances that fog becomes a valuable aid, and completes the necessary inertia.

FOG A DANGEROUS REMEDY.

There is yet another point to consider in this regard, namely, that the shadows or least exposed parts are more sensitive than those parts which have been already reduced—that is to say, there is more of the

stop; this will practically eliminate another factor—variation in the aperture of the lens. The same developer and printing process may be employed, and restricted to well lighted subjects, lit at an angle of 45°; this will eliminate any necessity to allow for the different rapidity of action of various developers, the different scale of gradation of the several printing processes, and the variations due to the manner of lighting. It remains, then, to consider only the variations due to colour and contrast in the subject. When this has been

TABLE B.
EXPOSURE AT /S FOR PLATES MARKED 1½ IN SPEED LIST.

Subject	A sec.	B sec.	C sec.	D sec.	E sec.	F sec.	G sec.	H sec.	I sec.	J sec.	K sec.
Sea Yachts and Clouds	$\frac{1}{25}$	$\frac{1}{30}$	$\frac{1}{35}$	$\frac{1}{40}$	$\frac{1}{50}$	$\frac{1}{25}$	$\frac{1}{20}$	$\frac{1}{15}$	$\frac{1}{10}$	$\frac{1}{8}$	$\frac{1}{5}$
Distant View, Fig. 165	$\frac{1}{20}$	$\frac{1}{25}$	$\frac{1}{30}$	$\frac{1}{35}$	$\frac{1}{40}$	$\frac{1}{50}$	$\frac{1}{40}$	$\frac{1}{30}$	$\frac{1}{20}$	$\frac{1}{15}$	$\frac{1}{10}$
Open Landscape, Fig. 164	$\frac{1}{15}$	$\frac{1}{20}$	$\frac{1}{25}$	$\frac{1}{30}$	$\frac{1}{40}$	$\frac{1}{30}$	$\frac{1}{25}$	$\frac{1}{20}$	$\frac{1}{15}$	$\frac{1}{10}$	$\frac{1}{7}$
View, Dark Foreground, Fig. 163	$\frac{1}{10}$	$\frac{1}{15}$	$\frac{1}{20}$	$\frac{1}{25}$	$\frac{1}{30}$	$\frac{1}{20}$	$\frac{1}{15}$	$\frac{1}{10}$	$\frac{1}{8}$	$\frac{1}{6}$	$\frac{1}{4}$
Portraits, Fig. 166	$\frac{1}{5}$	$\frac{1}{6}$	$\frac{1}{8}$	$\frac{1}{10}$	$\frac{1}{15}$	$\frac{1}{10}$	$\frac{1}{8}$	$\frac{1}{6}$	$\frac{1}{5}$	$\frac{1}{4}$	$\frac{1}{3}$
Interiors, Fig. 167	3 min.	5 min.	10 min.	30 min.							

silver bromide remaining to be converted to the metallic state. Hence the action for a further reason goes on more readily in the shadows. It will thus be seen how delicate is the operation of softening the contrasts by means of fog, and how liable it is to be overdone. On the whole, fog is a very undesirable remedy to adopt.

INTERPRETATION OF SUBJECT.

The use and consideration of the whole of the factors referred to will be governed, firstly, by the result desired, which in turn will be governed by the gradation and character of the subject, the photographer's impression of it, and how he wishes it to be rendered; and secondly, by the printing process which has to be employed, and the character and contrast of the negative. In order to simplify matters, it will be necessary to eliminate all the factors possible. In early exercises this may be done by using the same plates, which disposes of any consideration as to the relative sensitiveness of plates. As these exercises will take place about the same date and probably about the same time of day, it will only be necessary to adhere to the medium

thoroughly mastered, and not before, the other factors, one by one, may be included.

VARIED EFFECTS OF DIFFERENT SUBJECTS.

By using a slow plate, the worker will allow himself sufficient latitude for error in exposure to avoid any serious mistake, provided that sufficient exposure has been given. An exposure eight times greater than it should be is easily remedied, whilst even a more excessive exposure can be saved by very careful handling. It is most essential, however, that the varied effects on the plate of different subjects should

TABLE A.
LIGHT INTENSITIES AT DIFFERENT TIMES.

A.M.	P.M.	June	May or July	April or Aug.	Mar. or Sept.	Feb. or Oct.	Jan. or Nov.	Dec.
11 or 1		A	A	A	B	D	F	G
10 „ 2		A	A	B	C	F	G	H
9 „ 3		A	A	C	D	G	J	K
8 „ 4		B	B	D	F			
7 „ 5		D	E	F	H			
6 „ 6		E	F	H				
5 „ 7		G	H					

be well studied. The two tables given on this page will serve as a useful guide.

To use these tables proceed as follows: Take, for example, a subject such as Fig. 163, "near view with dark foreground," which is a very usual type of view, and suppose the occasion to be 3 p.m. in May. Look in Table A for May, and beneath this and level with the hours 9 and 3 will be found the letter A. In table B will be the exposure under this letter (A) opposite

do others which are considerably slower. Latitude is best illustrated by practical experiment. Take a whole plate printing frame, and remove the stop blocks from one end. Cut sixteen strips of card with perfectly parallel sides from a card measuring $6\frac{1}{2}$ in. by $10\frac{1}{2}$ in.; this is best done with a guillotine cutter, as they are then more likely to fit. Place a sheet of glass

SPECIMEN PAGE OF NOTE BOOK WITH PARTICULARS OF EXPOSURES.

SUBJECT.	Date.	Hour.	Stop.	Plate.	Developer.	Dia- meters.	LIGHT.	General Remarks.	Ex- posure.
Group: child, } cat and dog }	April 1	a.m. 9	f/4	S.R.	Normal.	—	Slightly cloudy	{ Bright negative for printing in platinum; No. 57021	$\frac{1}{4}$ sec.
Large group in open: light figures ... }	Sept. 23	3.30	f/16	Em.	{ No brom.	—	{ Sun just ob- scured; bright	{ Soft negative: No. 256 from P.O.P.	1 sec.
Street Scene: light fore- ground ... }	April 1	11.30	f/22	S.R.	Normal.	—	Full sunlight	{ Atmosphere clear; No. 34268	$\frac{1}{2}$ sec.
Library, non-ac- tinic colours: contrasts harsh ... }	Mar. 30	p.m. 1	f/32	Em.	Normal.	—	{ Large windows facing north; partly shaded	{ For platinum: No. 26871	30 min.
Average negative	—	—	—	Em.	Normal.	—	{ No. 5 gas burner 2 ft. away	{ No tissue paper used; trans- parency re- quired from negative for reproduction	1 sec.
Thin negative ...	—	—	f/2.5	{ Rapid brom. paper.	{ Metol and soda.	3	{ Two-wick pa- raffin lamp and condenser	{ Bromide en- largement to be made	4 mins.

the example Fig. 163, or $\frac{1}{5}$ th of a second, for an ordinary plate, and stop f8. If, say, a Cadett Lightning plate were used, $\frac{1}{20}$ th second would suffice.

ESTIMATING EXPOSURES.

In view of the large number of factors, and the many sub-divisions of each, it would be extremely difficult to devise a scheme for estimating exact exposures, and but for the fact that all plates allow a certain latitude of error it would be impossible. Latitude, although usually greater in slow plates than rapid ones, is not by any means entirely dependent upon speed. Some rapid plates of the best quality possess greater latitude than

$8\frac{1}{2}$ in. by $6\frac{1}{2}$ in. in the frame, and lay the strips on it, having rounded off the corners so that they then have the appearance shown in Fig. 171. Now fasten strips of card A A across so as to hold in the strips, in order that they may be pulled out one at a time. This cross strip may be fastened by driving tiny pins through it and between the strips. Set at 4 ft. from a candle flame, having previously placed the frame with an ordinary half-plate dry plate inside in the position of the dotted lines and replaced the back. No. 2 strip is then pulled out, and two seconds' exposure given; No. 3, four seconds; No. 4 eight seconds; No. 5 sixteen seconds; No. 6, thirty-two seconds; and so on, doubling the exposure each



RETOUCHED PHOTOGRAPH.

time. On development in a normal developer, an image like Fig. 172 is produced, which will show that Nos. 1 to 3 are alike, after which the exposures show a gradual increase of density up to No. 8, when the densities will remain the same. If such a plate were cut in parts, and each developed a little more, the set of gradations would move up as in Figs. 173 and 174. Now, as only about 6 to 1 can be registered on a print, this shows that modifying the length of development per-

not always quite the same, as experience will fully confirm.

THE SIMPLEST GUIDE TO EXPOSURE.

The simplest guide to exposure consists of tables calculated upon the table of the sun's altitudes given on p. 95, and for the sake of simplicity letters have been placed

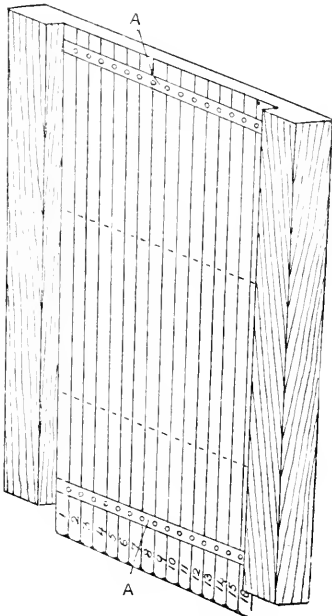

Fig. 171.—ARRANGEMENT FOR GRADUATED TESTS.

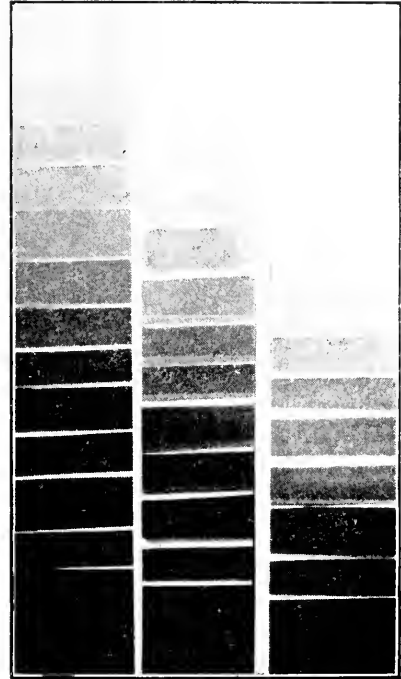

Fig. 172. Fig. 173. Fig. 174.
Figs. 172 to 174.—INFLUENCE OF DEVELOPMENT ON GRADUATION.

mits of considerable latitude in exposure. For example, if in Fig. 175 the plate were exposed only sufficiently to show the varying contrasts of the distant trees the figure would appear hard and black from under-exposure. Therefore, in such cases the proper plan is to over-expose such parts and then development may be continued until the detail is out in the darker portions. This has been put in the form of a rule which, although old, still holds good: "Expose for the shadows and let the lights take care of themselves." Strictly speaking, this should be: Expose for those parts in which detail is required. This is

to represent the varying intensities. A careful study of Table I., p. 87, will show that the exposure for a distant view at mid-day varies between June and December in the proportion of about 4 to 1. The same proportions apply to other subjects. At 9 a.m. or 3 p.m., fifteen times as much exposure is required in December as is required in June, and eight times as much in November. This is in the case of distant views, such as sea or sky, but in the case of a near view with dark foreground at the same time of day—9 a.m. and 3 p.m.—the proportions are as 1 is to 20. These tables should be carefully studied, noting in this way the

variations caused by the time of year, time of day, and nature of subject. Table B is calculated for $f/8$, this being the largest aperture at which most lenses work : but in the case of portrait lenses, which are occa-

is given, while with an " Ordinary " plate four times the exposure will be required. To make the tables of further benefit, a list of proportionate speeds, showing the degrees by which the exposure indicated



Fig. 175.—SUBJECT WITH LONG RANGE OF CONTRAST.

sionally used at apertures up to $2\frac{1}{2}$, the proportionate exposure is ascertained as before indicated by squaring the f numbers.

PROPORTIONATE SPEEDS.

These tables are drawn up for an Ilford Special Rapid plate ; if an Ilford Empress plate is used, nearly double the exposure

in the above tables must be multiplied, is given on the following page. It must be understood that these numbers merely represent approximately the proportionate rapidity of plates, as their sensitiveness is constantly varying. They will be found sufficiently correct, however, for practical purposes, and are intended only

as a rough guide for use with the various tables. The numbers have been arrived at after careful tests with pyro-soda developer.

✓ COMPARATIVE SENSITIVENESS OF DIFFERENT PLATES.

TABLE C.

				Proportionate Speeds.
Cadett,	Ordinary	2
..	Lightning	6
Imperial,	Special Rapid	5
..	Flashlight	6
Barnet,	Ordinary	1½
..	Rapid	3
..	Extra Rapid	4
..	Rocket	5
Faget,	xxx	2
..	xxxxx	4
Iford,	Ordinary	1½
..	Special Rapid	3
..	Monarch	6

FACTORS TO BE CONSIDERED.

It must be understood that although portraits and interiors are included in the above tables, the figures given can only serve as a very rough guide for these subjects, as the intensities of light in these circumstances vary so greatly. The amount of exposure required for a portrait taken in a room may vary from 1 to 16, and even more, according to the position of the model with regard to the light. In addition to this, there will be the other factors of subject, character of lighting, and degree of contrast, all of which render the exact estimation of exposure almost impossible. Figs. 166 and 167 should be a great help, as they indicate the type of portrait and interior. It is hardly necessary to point out that the light in either June or December is not always of exactly the same intensity. For example, the sun may be obscured by black clouds in gloomy weather, in which case from two to four times the exposure will be necessary. It is, however, assumed in the tables that the sun is obscured by light clouds, as it is seldom that even landscapes can be taken effectively in sunlight, although the direct reverse was once generally believed. In describing the subjects, they are assumed to be in

full light; this means that they are not shaded by intervening trees or buildings, which would greatly increase the exposure necessary. Useful as these tables are, however, they form merely a basis for working, and, if relied upon too implicitly, are apt to lead one seriously astray, and to destroy that confidence and self-reliance which are so essential to good work.

TESTING LIGHT INTENSITIES.

No estimates of exposure are likely to be accurate in all cases which depend upon these necessarily vague statements of light proportions. To estimate the intensity of light with any degree of accuracy, an experiment must be made. It is known that chloride of silver darkens under the action of light, and at first thought it might seem that this would serve as a good guide for estimating the power of the light. Unfortunately, the darkening action does not proceed in regular proportion. During the first few moments it is much more rapid than afterwards. Moreover, the action of light upon silver chloride is not in the same proportion as that of silver bromide. For these two reasons an experiment upon silver chloride would be of no practical use. Silver bromide, on the other hand, exhibits this darkening action only in a very slight degree. When, however, silver bromide is washed over with a soluble nitrate capable of absorbing the bromine liberated under the action of light, then the darkening of the compound proceeds rapidly and to a much greater extent. An experiment illustrating this fact may be useful. Take two strips of ordinary bromide paper, wash one over with a solution of silver nitrate, and expose the two to daylight; that which has been covered by silver nitrate will rapidly darken to a deep slate blue, whilst the other will never get beyond a faint steel grey.

EXPOSURE METERS.

This has brought about the introduction of exposure meters, which consist of an arrangement of figures that by a revolving or other device may be brought into different relation to each other, the figures being arranged under different headings, namely,

the factors governing exposure. Perhaps one of the simplest among these is the Ilford exposure meter. It consists of a series of three revolving discs as shown in Fig. 176. These indicate (1) plate, (2) diaphragm, (3) date and hour, (4) subject, and (5) required exposure, the first and last being fixed. To use it, the arrow on the date circle is placed on the circle opposite the plate to be used. Next, the arrow on the diaphragm circle is placed opposite the date and hour, and the arrow on the subject circle opposite the stop to be used. The necessary exposure in each case

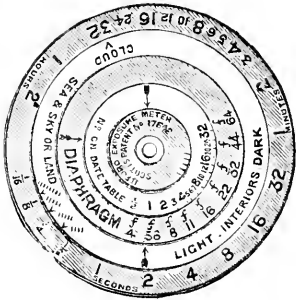

Fig. 176.—ILFORD EXPOSURE METER

will be shown opposite the subject. In other instruments means are provided for exposing a piece of the specially prepared bromide paper referred to above. By the side of the portion exposed are various tints through which the paper passes before reaching its deepest slate blue—one tint shows the darkest to which the paper will go, another tint shows the shade reached in half that time, a third that which it reaches in a quarter of the time, and, if desired, even lighter tints. The end revolving ring shows in one set a series of numbers representing the relative speeds of different makes of plates; another set shows the stop numbers from $f4$ up to $f64$; a third set gives a series of numbers representing in seconds or minutes the length of time the prepared bromide paper has taken to darken to the deepest tint. Another set shows the proportionate exposure required for different subjects; and the last set shows the correct exposure. If one of the lighter tints, such as a half-tint or a quarter-tint, is used in

matching the darkening of the paper, either the actinometer time or the exposure when found must be multiplied by the denominator of the fraction which they form of the actinometer time. For example, if a half-tint is used, the exposure will be double that directly indicated, and if a quarter-tint is used, four times that. As to whether the actinometer time or the actual time taken to darken the tint is multiplied by this number, or whether the exposure indicated by the instrument is so multiplied, is of no importance. The instrument described above is the

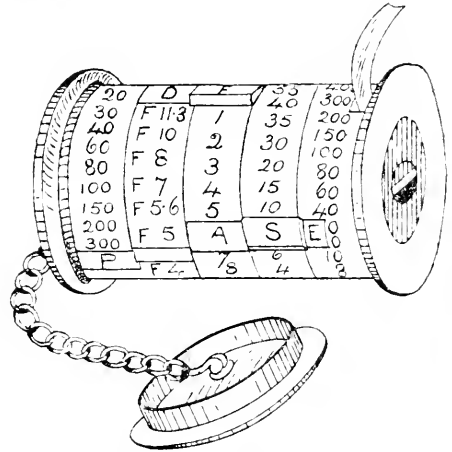

Fig. 177.—WATKINS' "STANDARD" EXPOSURE METER.

WATKINS' "STANDARD" EXPOSURE METER.

In addition to a simple actinometer for testing the light, it has a chain pendulum for counting seconds or half-seconds, which may be used either for camera exposure or for taking the actinometer time. The calculating numbers are set out upon brass rings revolving round a brass cylinder, each ring being labelled with the letter corresponding with the exposure factor, as will be seen by referring to Fig. 177. The chain of the pendulum is kept inside the cylinder and is enclosed by a cap which forms the weight of the pendulum. At the other end is a similar cap containing a circular window of blue glass, and beneath it the sensitive bromide paper is uncoiled and passed out through a slot in the cap. The object of the blue glass is to ensure the tint being more easily and more accurately matched.

HOW TO USE THE "STANDARD" METER.

To use this instrument, unfasten the lid of the pendulum box, then pull forward about $\frac{1}{8}$ in. of bromide paper, so as to have a new portion exposed beneath the window. Cover the window with the thumb, and, holding it opposite the deepest shadows of the picture in which detail is required, set the pendulum swinging and remove the thumb. Now count the number of seconds required to darken this to match the deeper tint at the side of the prepared portion of bromide paper; this gives the actinometer time. The speed of the plate must next be found, and for this purpose the instrument is provided with a set of speed numbers, showing the proportionate sensitiveness of all well-known brands. These numbers are to the extreme left of the instrument. Revolve ring P until it is over the number indicated by the speed of the plate; next revolve D until it is against the stop which is to be used; then revolve A until it is against the actinometer time, when the number against E which revolves with it will be the correct exposure.

POSITION OF EXPOSURE METER.

From what has already been said as to the position of the camera being no guide to the exposure required (p. 85), it will be seen that the exposure meter also must be held so as to gauge the light which falls upon the subject and not that which falls upon the camera. This is a matter about which there has been some little discussion, but it is rather surprising that any doubt should exist with regard to it. The light used in forming the picture is that which is reflected from it, and not necessarily that which reaches the object; but seeing that this is practically allowed for in dealing with variation of subject (p. 95), it will not be necessary to go further into the question here. In the case of views under trees, the meter should be exposed under the shade of the trees. With sunlit buildings it will suffice to expose the actinometer in the shade of one's body, and if the building is being taken in direct sunlight—that is, with a full front light—so that there are practically no shadows (a condition of things not

likely to occur in artistic work, but unavoidable sometimes in record photography), the meter may be exposed in unobstructed sunlight.

TESTING WITH EXPOSURE METER.

In counting seconds, it is a very good plan to commence with 0, otherwise, unless careful, it might result in counting one second short, a matter of less importance when the whole tint is used. In matching the tint, great care must be taken that it is neither lighter nor darker, as upon this the accuracy of the exposure depends. When the exposure is less than one second, the pointer E will indicate the number with a mark in front, such as 1—4, or 1—100, this should read $\frac{1}{4}$ or $\frac{1}{100}$ th of a second. When the actinometer time is more than a minute, A must be set to the number of minutes, and then E will indicate minutes instead of seconds. For general work the direct sunlight should not be tested, but the actinometer should point in a direction at right angles to it, so that diffused light may fall upon the paper. Where the shadows are not important, an average may be taken between sunlight and sky light for the actinometer time. In the case of sea and sky only, or with a distant landscape, the direct sunlight test alone may be taken.

TESTING INTERIORS FOR EXPOSURE.

When the exposure meter is being used to estimate for an interior picture, such as a church or a room in a house, the actinometer should be exposed in the worst-lighted part of the subject, or, at any rate, the worst-lighted part which is to show detail, as, for example, in the lower left-hand corner in Fig. 167. A saving of time may be effected in using the meter by employing the stop which will cause the camera and meter exposure to be the same. If the whole tint or darkest tint is employed for this purpose, the stop would need to be exceedingly small—so small, in fact, as to neutralise any benefit which might arise from this method of working. In photographing badly illuminated interiors, etc., the fractional tints are a considerable aid. In the case of the

“Standard” meter, the tints are on each side of the piece of paper, the quarter-tint side being distinguished by a white dot. Mr. Watkins has now upon the market a form of meter specially designed to indicate the exposures in indoor work; all that is necessary is to count the number of seconds taken to darken the paper to the quarter tint, this indicating the correct exposure when an Ilford ordinary plate is used and stop $f22$. Or, preferably, the meter may be left exposing, and the lens—stopped down to $f22$ —uncapped, and directly the paper has assumed the quarter tint the lens is again capped. The meter should be placed in the shadows of the picture. Slower or more rapid plates, of course, require more or less exposure. It has been found by experiment that the first



Fig. 178.—THE “BEE” METER.

visible darkening of the paper is equal to one-sixteenth of the whole tint. If this is used, a stop requiring $\frac{1}{4}$ the exposure of that just named or $f11.3$ must be used. In addition to those before mentioned, there is now a new form of Watkins meter made in the shape of a watch with revolving scales on the dial. It is called the “Bee” meter, and is shown by Fig. 178.

STOPS TO BE USED.

The method of finding the stops to use with these tints may best be made clear by a suggested experiment. Suppose an interior such as that shown in Fig. 167 is being dealt with, it is necessary to use a plate of the speed equal to 28, and to stop the lens down to $f22$; then place the meter pointing towards the window or the chief source of light. The meter may remain in the picture while the actual exposure is

going on. From time to time the strip of bromide paper may be drawn out and examined for an instant, and as soon as it shows the first sign of darkening, the plate in the camera will have been sufficiently exposed. If a quarter-tint is used, a stop necessitating four times the exposure, or $f45$, must be employed; and for a whole tint one requiring sixteen times the exposure. Such apertures, however, are not likely to be used for interior work if they can be avoided; but the whole tint may be utilised in outdoor photography. A table is given with the meter which

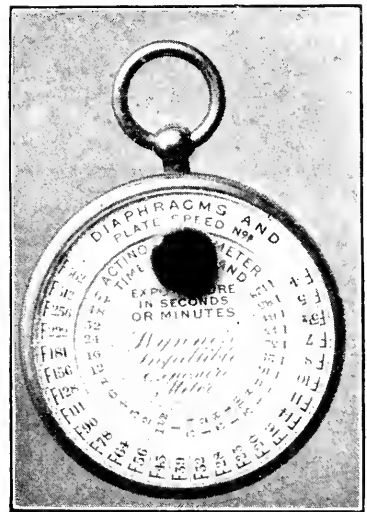

Fig. 179.—WYNNE'S EXPOSURE METER.

shows the plate speed and the stops to be used for the various tints: by this means calculation is entirely avoided, and exposure made as simple as possible. The subject number depends on its colour or the kind of rays which it reflects and those which fall upon it. Mr. Alfred Watkins gives the following formula:—Sky or sea, $s10$; snow scenes, extreme distance and seascapes, $s25$; average landscape, portraits, buildings, $s100$; for dark or non-actinic objects in which detail is required, $s200$. From these the proportionate exposures required by different subjects may be inferred.

THE "INFALLIBLE" EXPOSURE METER.

Another good form of meter is the "Infallible," introduced by Geo. F. Wynne, which selects from the numerous factors governing the exposure three only—light, plate sensitiveness, and stop. This instrument is founded upon the same principle as the Watkins exposure meter, the intensity being gauged by the time taken to darken to a standard tint. Two tints are provided, the darker one for general work and the lighter one for views under trees, interiors, or other dimly lighted subjects. Fig. 179

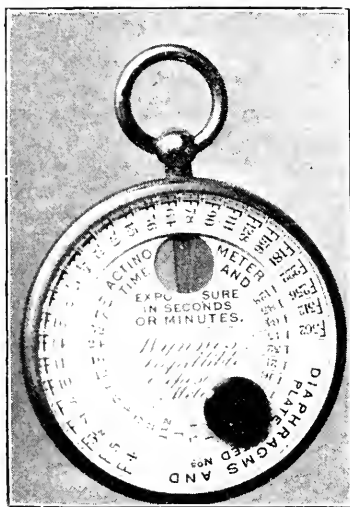

Fig. 180.—METHOD OF USING WYNNE'S METER.

shows one of these instruments. It is certainly of a very convenient shape, being in the form of a watch. The dial is in two parts, the outer ring bearing the f numbers or plate speeds, and the inner circle the actinometer time. At the top is a V-shaped opening, on each side of which are the two tints. This opening is covered when out of use by a piece of yellow glass cemented outside the glass dial. The dial is made to revolve so that any f number can be brought opposite any actinometer number. The back opens, and discloses a disc of prepared bromide paper backed by a piece of felt and a wire spring. Thus, to bring a fresh piece of paper before the

opening, it is only necessary to revolve the back half of the watch-case, when the sensitive paper will turn with it. Revolving the dial removes the orange glass, and leaves the paper ready for exposure. The actinometer time having been taken by carefully noting the number of seconds taken to darken to the tints as before described, the disc is revolved until the plate speed is against the actinometer number; then against every stop will be found the correct exposure, so that whichever is used the exposure will be known without calculation. Should the sensitive paper take minutes instead of seconds to darken to the standard tint, the actinometer time must be read as minutes, and the answer will be in minutes or fractions of minutes. A set of plate speeds are issued by Mr. Wynne, in a book sold with the meter.

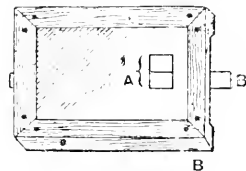

Fig. 181.—HOME-MADE EXPOSURE METER.

Suppose now the actinometer takes 48 seconds to darken to the deepest tint, and the plate speed $f/20$ is being used, then the dial will be revolved as shown in Fig. 180, when it will be seen that the exposure at $f/16$ is 32, and so on. Pinhole exposures are calculated in the same manner by dividing the diameter of the hole into the extension.

MAKING AN EXPOSURE METER.

In order to construct an exposure meter, make a series of tints of a neutral or blue grey on a strip of card about 2 in. by $\frac{1}{4}$ in. by applying to the card repeated washes of colour, each successive wash being a little shorter than the preceding; or the same end can be obtained by printing the tints from a graduated scale. Each successive tint must be just a distinguishable shade darker than the preceding. Fit this card in a small frame fronted with a sheet of blue glass and backed with a stout piece

of black paper in which is cut a slit A (Fig. 181) equal to the width of tint, and in length equal to the tint square, plus the width of the bromide paper B. Fig. 182 shows the order of filling the frame, c being the wood back; d, the felt pad; e, the tint; f, the

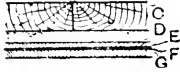

Fig. 182.—SECTION OF HOME-MADE METER.

black paper, and g, the blue glass. By this apparatus the ratio between the sensitiveness of the plate and the sensitiveness of the paper may be found, but for correct ratios it is essential that bromide paper,

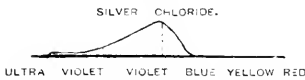

Fig. 183.—SILVER CHLORIDE SPECTRUM CURVE.

not printing-out paper, should be used. The action of a beam of light (or of the component parts of a beam) upon chloride of silver may be represented by the curve shown in Fig. 183, by which it will be seen

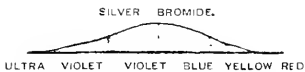

Fig. 184.—SILVER BROMIDE SPECTRUM CURVE.

that whilst considerable effect is produced by the blue and violet, very little reduction of silver is caused by the red, yellow, and green rays. On the other hand, the curve in Fig. 184 shows that bromide of silver, although most sensitive to blue, is more evenly sensitive, and by comparison of these curves (which are of course only rough) it will be seen that when the light is dull the meter will indicate too long an exposure. On the other hand, as glass is partially opaque to the ultra violet rays, the ratio will be different in this regard also. Ordinary bromide paper shows little or no change under the action of light, but if washed over with a soluble nitrate it darkens rapidly. Take, for example, two pieces of bromide paper and rub one over with a solution of silver nitrate and expose

them both to light, and the difference in action will be most apparent. Paper prepared in this way may be employed for exposure in the meter just described.

HOW TO USE HOME-MADE EXPOSURE METER.

To find the ratio between the actual amount of light received by the object and that impinging on the plate, proceed as follows: Hold the prepared frame in the light that illuminates the object or scene to be photographed, and count the number of seconds that elapse before the paper exposed in the frame darkens sufficiently to match the different tints, pulling out a fresh square of paper for each tint. Now photograph the scene or object, the correct exposure for which is to be ascertained by exposing the plate a bit at a time. This is done by drawing the slide one-tenth of the way out and giving one second of exposure, and so on. When the last exposure has been made the different portions of the plate will have had the following exposures—namely, 10 sec., 9 sec., 8 sec., 7 sec., 6 sec., 5 sec., 4 sec., 3 sec., 2 sec., 1 sec. That division which, on development with normal solution, shows the best gradation is the division that is correctly exposed. The exposure needed to obtain the result desired, compared with the time taken to darken the paper to the selected tint, shows the proportions the two bear to each other. For instance, if at f 32 a distant view, well illuminated, required 1 sec. with plate speed 30, whilst the bromide paper in the same light needed 10 sec. to darken to tint 3, for such scenes, and under such conditions of plate speed and f ' ratio the exposure for the plate in the camera is $\frac{1}{10}$ the tint exposure. (These figures must not be taken as actual proportions, but only as a guide. The proportion depends on the tint, and must be found by experiment, as directed.) Suppose now that a similar subject, with a plate speed of 60 and f 8, gives sufficient depth and definition whilst the tint exposure is 60 sec., then as the increase of the plate speed will reduce the exposure to $\frac{1}{2}$ and f 8 to $\frac{1}{16}$ of that (as $f/8^2 : 32^2 :: 1 : 16$), and, as the plate

exposure is $\frac{1}{10}$ of the tint exposure, then

$$r = \frac{T}{r(a \times b)} = \frac{60}{10 \times 32} = \frac{3}{16} \text{ sec.}$$
 if T = the time taken to darken, r = the ratio between actinometer and plate, a = the proportionate plate speed, and b = the proportionate f/ value. Speaking roughly, this may be stated to give the correct exposure in seconds for, say, f 5.6. In the same light ascertain the length of time in seconds required to tint the paper to either of the tints. This gives the proportion of actinometer to plate. Say that the time required is sixteen times as long as the exposure, then the actinometer will ever afterwards, provided the same speed plates are used, indicate the exposure for f/22, from which the exposure may be calculated with ease for any other stop.

INSTANTANEOUS PHOTOGRAPHY.

Closely connected with the subject of exposure is that of instantaneous photography, in which a further consideration occurs governing the duration of exposure. With rapidly moving objects, such as are shown in one of the page plates, the question is not what is the proper length of exposure, but which is the longest duration of exposure the movement of the object will allow. Having discovered this, the proper plate and stop are chosen. It seldom happens, however, that the exposure necessary can be given, and modified development followed by considerable doctoring of the negative must be carried out. The maximum amount of exposure is dependent upon the rate of movement, the distance of the object, and the focus of the lens. By dividing the distance of the object in inches by the focus of the lens, multiplied by 100, and dividing the rapidity of motion in inches per second by the result, the longest permissible exposure in the fraction of a second is obtained. Thus, let d = distance of object, f = focus of lens, and s = speed in inches per second. Then

$$x = \frac{d}{f \times 100} \div s.$$

So that if

$$d = 540 \text{ in.}, f = 8 \text{ in.}, \text{ and } s = 360 \text{ in.},$$

then

$$x = \frac{540}{800} = \frac{27}{40} \div 360 = \frac{1}{533} \text{ second.}$$

This formula is based upon the fact that the eye cannot detect a movement of less than $\frac{1}{1000}$ th of an inch, so that it is generally said that the circle of confusion must not exceed $\frac{1}{1000}$ th of an inch.

ESTIMATING SPEED OF MOVING OBJECTS.

The first difficulty will be that of estimating the speed at which the object is moving, and to assist in this the following table is given, showing the distance in inches per second:—

Man walking (3 miles per hour) ...	54
Ship moving (12 knots per hour) ...	228
Torpedo boat ... (about) ...	420
Trotting horse	432
Galloping horse	600
Locomotive (40 miles an hour) ...	708
Pigeon	732
Locomotive (60 miles an hour) ...	1,056
Skylark	3,528
Cannon-ball	18,000 to 24,000

Supposing now that the speed at which the object is moving is known and the shutter is limited to a certain speed, then it is necessary to ascertain at what distance the camera must be placed in order to show the least permissible movement. In this case it is necessary to multiply 100 times the lens focus in inches by the space in inches through which the object would pass during the exposure proposed to be given. This gives the minimum distance at which the camera may be placed. For example, suppose it is desired to photograph a galloping horse with a lens of 8 in. focus fitted with a shutter which works at $\frac{1}{90}$ second, at what distance, or how near, may the camera be placed?

Let m = movement, f = focus, and d = required distance: then $m \times 100.f = d$; or, in the imaginary case given above,

$$600 \div 90 = 6\frac{2}{3}; m = 6\frac{2}{3}, f = 8,$$

then

$$6\frac{2}{3} \times 800 = 148 \text{ yd. } 5 \text{ in.}$$

In this way the displacement on the ground glass of any object may be estimated.

THE HURTER AND DRIFFIELD ACTINOGRAPH.

The "H. & D." Actinograph consists of four sliding scales, representing the speed numbers of plates, a rough classification of the intensities of light, the stop numbers, and curves for every day of the year and hour of the day, or such as are likely to be used. The rough classification of light intensities refers more particularly to the atmospheric condition of the time of exposure. The following example will serve to show how the instrument is used:—Date, September 20; time, 3 p.m.; stop, $f/11$; plate speed, 20; light, mean. To find the exposure, push the scale upwards until the date September 20 comes into view along the edge of the lens scale; put the speed index to 20; then move the top until $f/11$ meets the curve on the light scale marked 9 and 3. The necessary exposure will now be found opposite the part marked "Mean."

CONCLUDING HINTS ON EXPOSURE TO
BEGINNERS.

In summing up the matters dealt with in this section, it must be pointed out that the operator cannot possibly take into account

every essential detail at the moment of exposure. All that he can hope to do, having carefully considered the factors, and used them as a basis, is to strike an average. It will be interesting and instructive to compare the several systems here described. Generally speaking, they agree in result very nearly; they may sometimes be rather contradictory, but they seldom indicate an exposure which is seriously incorrect. Of the various exposure meters, the Wynne "Infallible" may be recommended for its simplicity; while, on the other hand, the extra modifications provided by the Watkins meter will be found of great value where a variety of work is undertaken. Students should first use the simple tables given on pp. 95 and 96, together with the illustrations accompanying them, making full use of the note-book described, until they have obtained sufficient experience to estimate exposure with a fair amount of accuracy. They should then procure one of the exposure meters; using it with care and judgment. Above all, they should remember the influence which the alteration of the contrast may have upon the impression presented in the picture.

DEVELOPMENT OF PLATES AND FILMS.

INTRODUCTION.

DEVELOPMENT is regarded as one of the most important processes of photography, and too much attention cannot be given to attaining a proper mastery and control of all its branches. Although it is true that the ultimate object of the photographer is the production of satisfactory prints, and that much may be done during the operations of printing to modify and atone for defects of the negative, really good prints cannot be expected when the negatives are absolutely bad. Moreover, it is undeniable that the best prints are obtained from those negatives which are not only correctly exposed, but suitably and discriminately developed. It is far better to avoid, if possible, the necessity of any after-treatment of the negative, while the saving of time and trouble is obvious. It is not proposed to deal here with the theoretical or chemical side of development; this will be treated separately in a later section. In this chapter the different practical operations of development will be explained, the merits and properties of the various reducing agents considered, and all necessary explanation and advice given to render the successful development of any given exposure a matter of ease and certainty.

STANDARD FORMULA.

The developer now perhaps most in use is pyrogallol, or pyrogallic acid; this, therefore, will be considered first, and its action and the properties of its different constituents carefully examined. By so doing, a good idea will be obtained of the manner in which other developers are compounded, and how the different results are

obtained by their use. A further advantage of taking the pyro. developer as an example is that there appears to be none superior to it, and that it is probably the reducing agent which the beginner will adopt for ordinary everyday work. The following solution, then, will be taken as a normal developer. Properly speaking, it would be made up in two solutions, but it is here given as one, to facilitate analysis:—

Pyrogallic acid	20	grs.
Potassium bromide	5	grs.
Sodium carbonate	160	grs.
Sodium sulphite	160	grs.
Water	10	oz.

CONSTITUENTS OF A NORMAL DEVELOPER.

In the formula just given, the pyrogallic acid is known as the reducer, its function being to reduce the exposed silver bromide of the plate to the form of metallic silver. This function, however, it would not be able to carry out quickly enough, or to a sufficient degree, by itself, so that an alkali, or accelerator, has to be added to facilitate the reducing action: this duty is fulfilled, in the present case, by the sodium carbonate. The developer as now constituted would probably be a trifle too active for ordinary purposes; it would tend to cause fog or flatness of image. A third constituent is therefore needed to bring the developing action more under control. This is the potassium bromide, or restrainer, which steadies and curbs the undue activity of the solution. There now remains only the sodium sulphite to consider. It should be explained that most developers are readily oxidised and spoilt

when exposed to air, even to that small amount of air which is admitted each time the bottle is opened, for a reducer is a substance which is greedy of oxygen. Pyro. is especially sensitive in this respect, and would become discoloured and useless in a very short time if some means of preserving it were not adopted. The sodium sulphite is a great absorbent of oxygen, and consequently, by taking up all this element which finds its way to the solution, acts as a preservative, and enables the developer to be kept, without deteriorating, for a long time.

VARYING THE COMPOSITION OF DEVELOPER.

From what has been said of the action of the various constituents of a developer, it is evident that the composition may be varied or modified to suit special requirements. A plate that is under-exposed may, for instance, be treated with a developer containing no bromide: one that is over-exposed with less accelerator and a greater proportion of bromide, and so on. The worker has thus a valuable power ready to his hands, enabling him in special cases to remedy mistakes and to anticipate possible difficulties.

REDUCERS: ACID, ALKALINE, AND NEUTRAL.

Some developers will only work satisfactorily when in an acid condition, the ferrous oxalate developer affording a good instance. Others require the addition of an alkali, having no reducing power in themselves. Pyrogallol and hydroquinone belong to this group. Other reducing agents require neutrality of the solution as a condition of successful working. These considerations are of little practical importance provided the given formulæ are carefully adhered to, and will be more suitably dealt with in the theoretic section.

ACCELERATORS.

At one time ammonia was the accelerator almost universally employed with the pyro. developer. It has many good points, being rapid in action and giving excellent detail. It possesses, however, the disadvantage of tending to produce fog, especially in cases of under-exposure; besides

which its strong, pungent smell is very objectionable. Modern dry plates appear to be more susceptible to fogging by the use of ammonia than the older makes, and, consequently, sodium carbonate has practically superseded ammonia in general favour. Sodium carbonate is identical with common washing soda; but as the latter is frequently adulterated, it is advisable to obtain the pure salt at the photographic dealers'. It is also procurable in the anhydrous form, without water of crystallisation. This variety is much stronger than the crystalline form, and must be used in smaller proportions. In the majority of formulæ the term sodium carbonate is intended to mean the crystals. Potassium carbonate is employed as the alkali in some cases; this must be kept in well-stoppered bottles, and dried in an oven before using, as it absorbs moisture from the atmosphere with avidity. Ammonium carbonate is occasionally used instead of ammonia, but is less effective for ordinary work than the former. All the accelerators mentioned may be used with pyro., as well as with some other developers. Caustic soda and caustic potash (sodium and potassium hydrate) cannot be used with pyro., but are excellent in conjunction with hydroquinone, pyrocatechin, kachin, and other reducers. They should be purchased in sticks, and should be perfectly dry. Being very absorbent, they must be kept in well-stoppered bottles.

RESTRAINERS: PHYSICAL AND CHEMICAL.

It is necessary to use a soluble bromide with the caustic alkalies, and in some cases with the carbonates. When the alkali is ammonia, ammonium bromide may be employed; otherwise potassium bromide should be used. Bromide has more effect in restraining the least exposed portions of a negative than on the better lighted portions. As a result, it gives greater brilliancy and contrast. In cases of over-exposure, where a flat, lifeless negative is to be expected, this property of bromide is turned to account, the addition of a small quantity to the developer often sufficing to save an otherwise doomed plate. An example of this is given in one of the

full-page plates, which shows an over-exposed plate, the lower half of which was developed without bromide, and the upper half with a small quantity. Some workers omit the bromide from their developer. In very cold weather this may be desirable, but as a rule better results will be obtained by retaining it. Temperature has a marked effect on the developing solution: a warm solution acts more rapidly, and a cold one will often appear almost inert. The best temperature is from 60° to 65° F., and the dark-room should be maintained at that degree of warmth. Diluting the developer will slow it according to the amount of dilution, but this also has the result of reducing contrast and producing a softer negative. As a rule, it is better to rely on modifying the constitution of the developer by the addition of alkali or bromide, as the case may be, rather than on variation of temperature or dilution.

DEVELOPING FORMULÆ.

A large number of different developing agents will now be considered, and practical formulæ and directions given for working. Although the photographer is strongly advised to fix on one developer, and adhere to that, it may be pointed out that many of these reducing agents have some special property or characteristic not possessed by the others, a knowledge of which will be of great service to the worker.

PYRO. AND AMMONIA.

STOCK SOLUTIONS.

No. 1.—Liquor ammoniac, 88° ...	1½ oz.
Potassium bromide ...	8 drs.
Water ...	6½ oz.
No. 2.—Pyrogallie acid ...	1 oz.
Citric acid ...	2 drs.
Water ...	8 oz.

For use, take 1 oz. each of No. 1 and No. 2, separately, and dilute with 15 oz. of water. Label these solutions A and B respectively. Equal parts of A and B are taken for development. The ammonia solution must be kept well corked, or it will lose strength by evaporation. The strong ammonia requires to be opened with care, and must not be exposed to

a sudden rise of temperature, or an explosion may result. In making up No. 2, dissolve the pyro. in the water first, and add the acid last.

PYRO. AND SODA.

STOCK PYRO. SOLUTION.

Pyrogallie acid ...	1 oz.
Potassium bromide ...	60 grs.
Potassium metabi-sulphite ...	50 grs.
Water ...	12 oz.
No. 1.—Stock solution ...	3 oz.
Water ...	20 oz.
No. 2.—Sodium sulphite ...	2 oz.
Sodium carbonate ...	2 oz.
Water ...	20 oz.

For use take equal parts of No. 1 and No. 2. Boiled or distilled water is best, but not absolutely necessary.

PYRO. AND METOL. (Sandell Formula.)

No. 1.—Pyrogallie acid ...	80 grs.
Metol ...	70 grs.
Potassium metabisulphite ...	140 grs.
Potassium bromide ...	30 grs.
Water ...	20 oz.
No. 2.—Sodium sulphite ...	1 oz.
Sodium carbonate ...	3 oz.
Sodium hydrate ...	60 grs.
Water ...	20 oz.

For use, take equal parts of No. 1 and No. 2 for normal exposures. This is a rapid developer, and gives excellent detail: besides being useful for all ordinary purposes, it is especially adapted for hand-camera work.

PYRO-ACETONE.

Sodium sulphite (anhydrous) ...	5 parts
Acetone solution ...	10 parts
Pyrogallie acid ...	1 part
Water ...	100 parts

Acetone was introduced by Messrs. Lumière as a substitute for alkali, the above being the formula recommended by them. It is a good all-round developer, clean and efficient in action.

HYDROQUINONE, OR QUINOL.

No. 1.—Hydroquinone ...	120 grs.
Sodium sulphite ...	2 oz.
Water ...	20 oz.
No. 2.—Potassium carbonate ...	4 oz.
Potassium bromide ...	30 grs.
Water ...	20 oz.

The hydroquinone must be completely dissolved before the sulphite is added. For use, take equal parts of No. 1 and No. 2.

HYDROQUINONE—SINGLE SOLUTION.

Sodium sulphite	2 oz.
Potassium carbonate	2 oz.
Hydroquinone	90 grs.
Water	10 oz.

This solution will not keep more than twenty-four hours after preparation. Hydroquinone is noted for its density-giving properties, and is invaluable where brightness and vigour are desired, as in copying, making transparencies and lantern-slides, photo-mechanical work, etc. For work where greater softness is necessary, a combination of hydroquinone and metol is to be preferred. Negatives developed with hydroquinone lose more in fixing than usual, and this must be allowed for. The developer is also extremely slow at a low temperature.

METOL.

No. 1.—Sodium sulphite	1 oz.
Metol	44 grs.
Water	10 oz.
No. 2.—Sodium carbonate	1 oz.
Water	10 oz.

For use, take equal parts of No. 1 and No. 2. Potassium carbonate may be substituted for the sodium carbonate if desired, the proportions being the same as before. Metol is an extremely active developer, and produces soft, delicate negatives. It has the peculiarity of bringing out the detail of the negative first, and gradually building up the density. It is equally suitable for plates, bromide prints, and lantern-slides. This developer is of especial value where detail rather than contrast is desired. Where prolonged development is required, a little potassium bromide should be added; but for average work this is unnecessary. A combination of metol and hydroquinone gives the density-forming character of the latter combined with the detail-giving qualities of metol. With some persons, metol produces a disagreeable eruption of the skin, if used to any extent; but this rarely happens.

METOL—SINGLE SOLUTION.

Metol	35 grs.
Sodium sulphite	$\frac{1}{2}$ oz.
Sodium carbonate	$\frac{1}{2}$ oz.
Potassium bromide	3 grs.
Water	10 oz.

This formula will not keep quite so well as the two-solution developer.

METOL AND HYDROQUINONE.

Metol	10 grs.
Hydroquinone	36 grs.
Potassium metabisulphite	15 grs.
Sodium carbonate	1 oz.
Sodium sulphite	$\frac{3}{4}$ oz.
Water	14 oz.

For use, take 1 part developer and 1 part water. Two drops of a 10 per cent. solution of potassium bromide should be added to each ounce of the diluted developer, except in cases of under-exposure or where special softness is desired. This developer is admirably suited for hand-camera exposures, as well as for bromide and gas-light papers, giving with the latter beautiful velvety-black prints; it is also well adapted for ordinary work of all descriptions.

METOL AND HYDROQUINONE.

No. 1.—Metol	40 grs.
Hydroquinone	48 grs.
Sodium sulphite	120 grs.
Water	8 oz.
No. 2.—Potassium carbonate	1 oz.
Water	40 oz.

This gives the greatest degree of control possible with a two-solution developer. For use with normal exposures, take 1 oz. of No. 1 and 3 oz. of No. 2. For over-exposure use less of No. 2, or add a few drops of bromide solution; for under-exposure, use more of No. 2. The metol and hydroquinone developer, like most of the non-staining reducers, may be used repeatedly, but becomes gradually slower with use.

FERROUS OXALATE.

No. 1.—Potassium oxalate	4 oz.
Water	16 oz.
No. 2.—Ferrous sulphate	4 oz.
Citric acid	15 minims
Water	12 oz.

For use with normal exposures, take 4 oz. of No. 1, and add gradually 1 oz. of No. 2. For a restrainer, a 10 per cent. solution of potassium bromide may be employed, 10 minims of this added to the mixed developer being a distinct improvement if the plate is fully exposed. As an accelerator, a solution of hypo. 1 part to 25 parts of water is useful. In cases of under-exposure, from 3 to 20 minims of the latter may be added to each ounce of mixed developer. It is better, however, to avoid the use of hypo. if possible. The ferrous-oxalate developer, as already stated, will only work satisfactorily when in an acid condition. It has the great merit of not reducing any portions of the silver bromide on the plate except those which have been exposed to the action of light; that is to say, it has no fogging effect. On this account, it is largely used in testing the speed of plates, and for similar scientific purposes. It has the defect of not keeping very well, and it is comparatively slow. The oxalate solution should be dissolved in hot water, and the iron in lukewarm water. The latter solution has the worst keeping properties, and quickly spoils on exposure to air. To avoid this, it should be kept in a number of small bottles, filled up to the cork, instead of in one large bottle. If this plan is adopted, and the corks are covered with wax, the solution will keep some time. With this developer a clearing bath is necessary before fixing, and it is advantageous to use another clearing bath after fixing. The object of this is to prevent the formation of various precipitates likely to occur if the water contains lime, and in some other circumstances.

CLEARING BATH FOR FERROUS OXALATE.

This is made up of acetic acid, 1 dram, and water, 20 oz. The plate or paper must be rinsed several times in the clearing bath, the solution being changed each time. The ferrous-oxalate developer, although now seldom used for plates, is difficult to surpass for bromide paper, and many of the best workers refuse to use any other. It must be admitted, however, that the necessity of employing a clearing-

bath is a serious objection when time is of importance. This developer may be used repeatedly, getting slower each time, and has the curious property of partly recovering its lost activity after being exposed in a white bottle to sunlight for several days. It is especially useful with plates which are known to be stale, as it is unlikely to produce markings or stains. All traces of pyro. must be kept away from dishes intended for use with the ferrous-oxalate developer, or black stains will result, due to the combination of the pyrogallic acid with the iron salts.

AMIDOL.

Amidol	20 grs.
Sodium sulphite	250 grs.
Water	10 oz.

This developer is principally employed for "snap-shot" negatives and bromide papers. It is active, and gives excellent detail. An interesting feature of this developer is that no alkali is required, the sodium sulphite alone being necessary. Unfortunately, it will not keep for more than a few hours in solution, and should therefore be made up as required. A slight trace of bromide added to the developer is generally an improvement. Amidol gives bright, vigorous negatives of a good black colour.

EIKONOGEN.

Eikonogen	75 grs.
Sodium sulphite	300 grs.
Potassium carbonate	150 grs.
Water	15 oz.

Eikonogen is notable for the great softness and delicacy of its results, and somewhat resembles metal in bringing out detail before density. It gives negatives of excellent colour and free from stain. It is not very soluble in water, and a solution of eikonogen tends to vary in strength at different temperatures. It is very suitable for portraiture and for subjects possessing great contrast of light and shade, where it is desired to obtain a negative free from hardness. It can be used to complete the development of a plate, commenced with some other developer, that shows signs of hardness. Pyro. and eikonogen, hydroquinone and eikonogen, with several other

combinations, possess qualities which form a compromise between those of the component developers.

GLYCIN.

Glycin	100 grs.
Sodium sulphite	100 grs.
Potassium carbonate	100 grs.
Water	10 oz.

Hot water should be used in making up this solution. Glycin is a somewhat slow developer, giving a grey-black, vigorous negative. It is a favourite for photo-mechanical work; and on account of its finely grained deposit is much used for microscopic work and in the making of negatives for enlargement. It is very steady and progressive in action, and is therefore often employed for stand development, where the negatives are placed upright in a grooved rack filled with very dilute developer, covered over, and left for some hours. An excess of alkali must be avoided with glycin, as it is liable to produce colour fog.

ORTOL.

No. 1.—Ortol	70 grs.
Potassium metabisulphite	35 grs.
Water	10 oz.
No. 2.—Sodium carbonate... ..	1½ oz.
Sodium sulphite	1¾ oz.
Potassium bromide	7 grs.
Sodium hyposulphite	2½ grs.
Water	10 oz.

For use, take equal parts of No. 1 and No. 2. Ortol much resembles pyro. in general behaviour, with the exception that it gives excellent black negatives free from stain. It will, however, stain the negative if kept sufficiently long to discolour, or when made up without a preservative, such as sodium sulphite or metabisulphite. It will keep fairly well if kept tightly stoppered, and may be used repeatedly within reasonable limits, growing slower in action each time.

PARAMIDOPHENOL.

No. 1.—Paramidophenol hydr chloride	½ oz.
Potassium metabisulphite	¼ oz.
Water	25 oz.
No. 2.—Sodium sulphite	1½ oz.
Potassium carbonate	1½ oz.
Water	25 oz.

For use, take 1 part of No. 1 to 2 parts

of No. 2. Paramidophenol is the basis of rodinal, and forms a steady and cleanly developer. It is not readily affected by changes of temperature, and is consequently a good reducer for winter use. It is admirable for the development of rapid exposures, although time is sometimes required to obtain satisfactory density. It is also well adapted for bromide papers.

RODINAL.

Rodinal is a prepared solution of paramidophenol, and only requires the addition of water to be ready for use. A normal rodinal developer for plates is made up of rodinal solution, 1 part, and water, 30 parts. For under- or over-exposure the strength of the solution is modified, according to requirements. With a stronger solution the addition of a few drops of 10 per cent. bromide is advisable. Rodinal is very rapid in operation, but the negatives lose strength considerably in the fixing bath, and this must be allowed for. Another form of rodinal is obtainable as a powder, which simply requires dissolving in water; it is sold under the name of Unal, and is very convenient for use when travelling.

PYROCATECHIN.

No. 1.—Pyrocatechin	96 grs.
Sodium sulphite	360 grs.
Water	10 oz.
No. 2.—Potassium carbonate	1 oz.
Water	9 oz.

For use, take 1 part of No. 1 and 2 parts of No. 2. Pyrocatechin gives bright, clear negatives of satisfactory printing quality. In its properties and results it is not unlike hydroquinone, but does not keep very well when made up. It is a favourite with some for the development of portrait negatives, although equally suitable for most other kinds of work. It is tolerably rapid in action, and requires dilution in warm weather.

ADUREL.

No. 1.—Adurel	85 grs.
Sodium sulphite	1¾ oz.
Water	10 oz.
No. 2.—Potassium carbonate	1¼ oz.
Water	10 oz.

TWO MINUTES' EXPOSURE

EXAMPLES OF FACTORIAL DEVELOPMENT. (See page 116.)

12 SECONDS' EXPOSURE

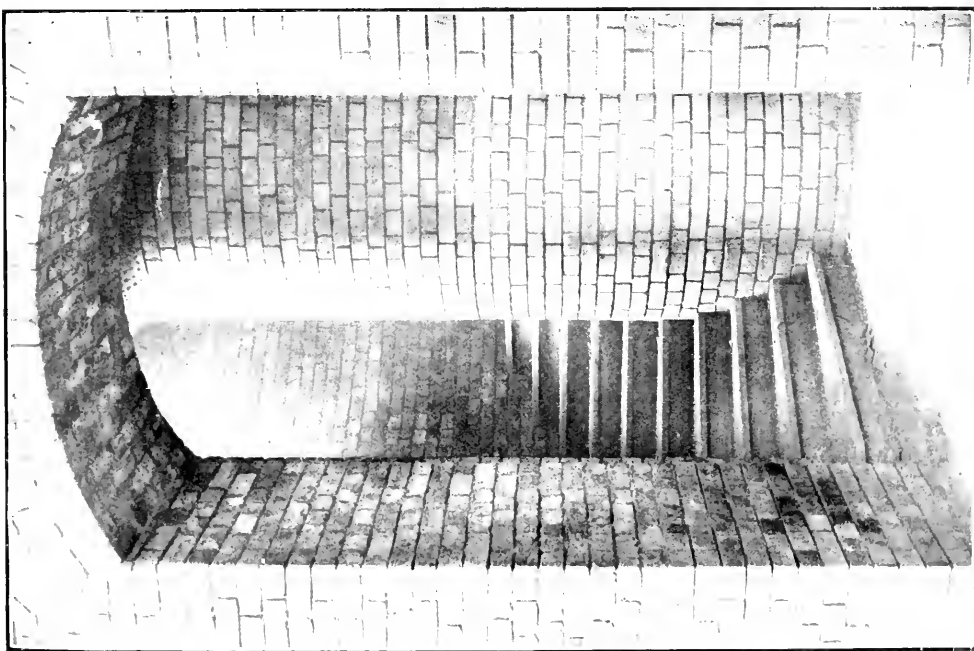
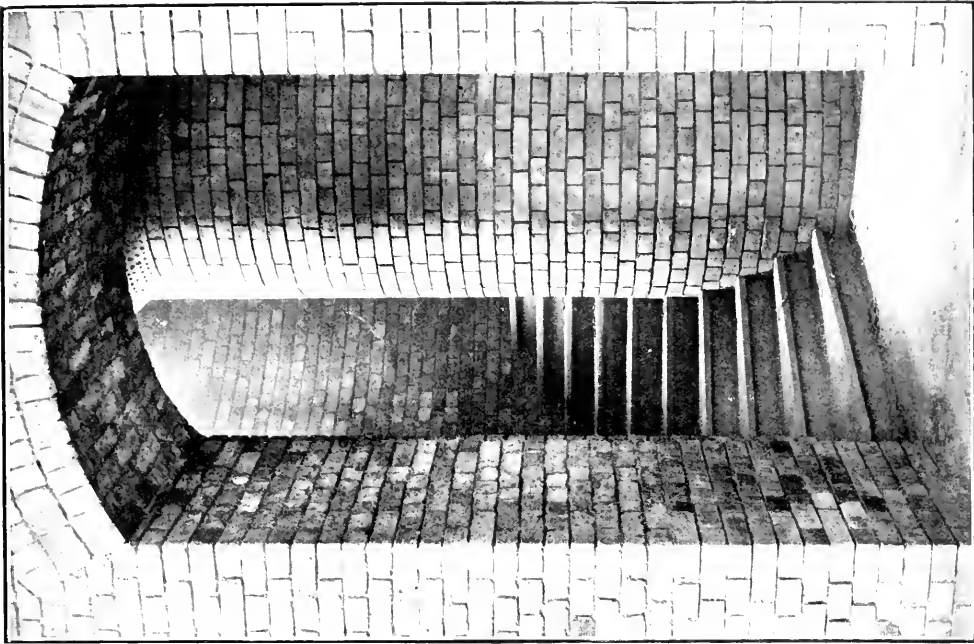

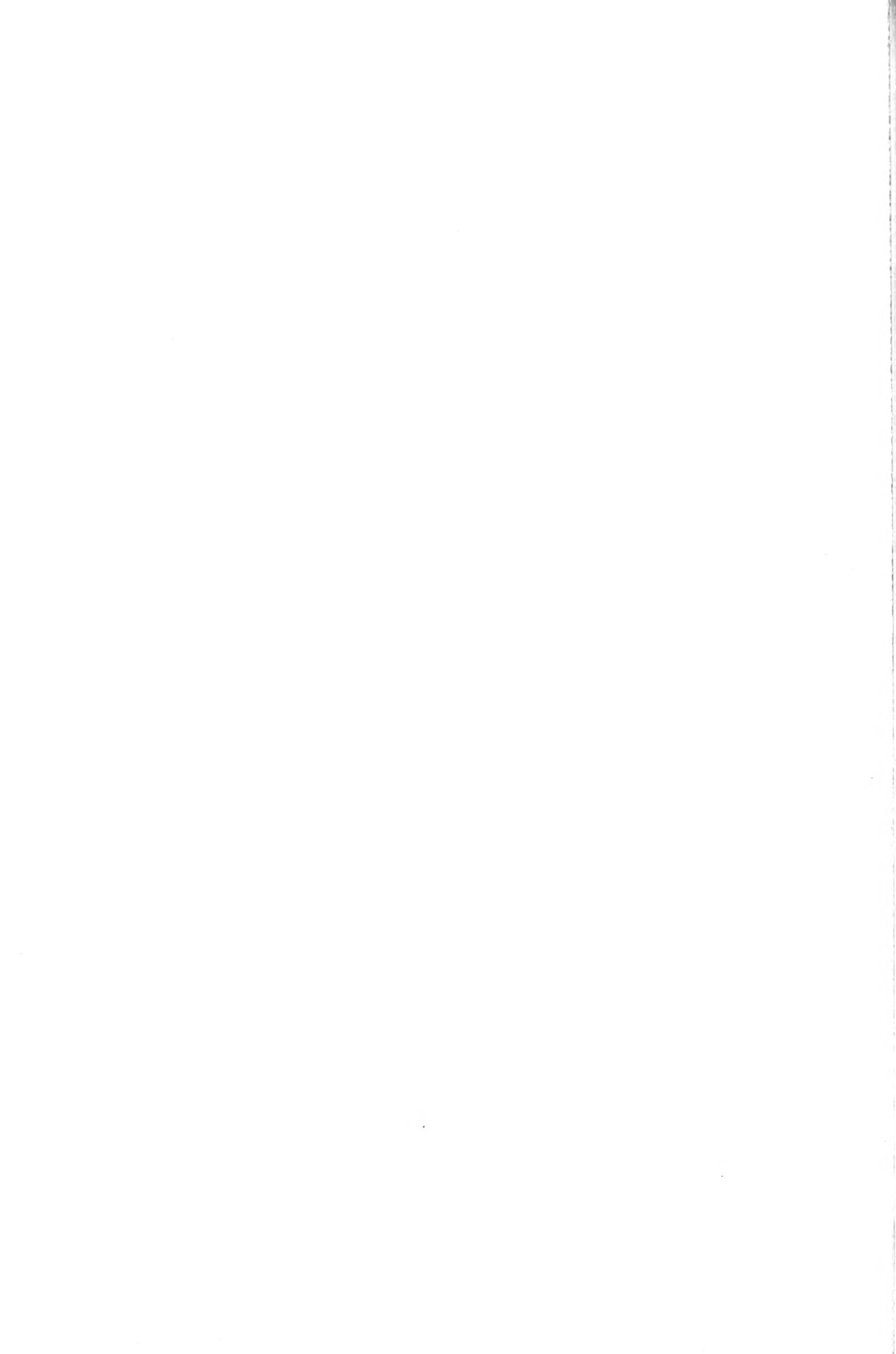

For use, take equal parts of No. 1 and No. 2, but for exposures of more than a fraction of a second dilute by the addition of 1 part of water. Aduro is very similar to hydroquinone in general characteristics. It is, however, more rapid in action, and affords greater opportunity of control by the addition of bromide. There are two forms of aduro obtainable, Schering's and Hauff's; both are put up as powders, which keep very well; and they keep fairly well in solution.

KACHIN.

Kachin	48 grs.
Sodium sulphite	$\frac{1}{4}$ z.
Sodium carbonate	$\frac{1}{2}$ oz.
Water	10 oz.

Kachin is obtainable as a white powder, and keeps well. It is very uniform in action, and free from any liability to stain the plates. It is especially suitable for stand development, and for use with plates suspected of staleness. The formula given is well adapted for snap-shot and ordinary work.

IMOGEN SULPHITE.

No. 1.—Imogen sulphite	53 grs.
Sodium sulphite	1 oz.
Water	10 oz.
No. 2.—Sodium carbonate	2 oz.
Water	10 oz.

For use, take equal parts of No. 1 and No. 2. Imogen sulphite is a recently introduced developer, obtainable in powder form. It keeps fairly well, but tends to become slower. It gives good, clean negatives, of excellent printing quality.

OTHER DEVELOPING AGENTS.

There are sundry other developing agents, principally of patent composition, among which may be mentioned Diogen, Dianine, Hydramine, Edinol, Synthol, etc.; but as they are not very frequently used, and as, moreover, suitable formulæ and working instructions are generally obtainable with the developer, further description is unnecessary. It is the practice of some professional photographers to treat almost every exposure in the same manner, with one general developer.

Where a large amount of work has to be quickly accomplished, this system is not without its advantages, although, of course, there must be a certain proportion of spoilt negatives which would have been saved by special treatment. The amateur must, however, remember that in commercial work the chances of error in exposure are much less, as the work is done under more regular conditions.

DEVELOPING ON A LARGE SCALE.

It is now proposed to describe a typical afternoon's work in developing, as pursued in some large establishments. It will be supposed that the pyro-soda developer as given on p. 109 is to be used, and that there are, say, two dozen half-plate negatives waiting for development. Sufficient developer is mixed from the two bottles of stock solution, allowing about 2 oz. for each plate, and placed ready to hand in a large glass jug. The fixing-bath is poured out from the vessel or jar in which it is stored, the lamp is lighted, and the box containing the exposed plates placed on the bench. A stoppered bottle containing a 10 per cent. solution of potassium bromide is also close at hand. Where there are a large number of plates to be developed, it is more usual to do them several at a time. In this instance, it is perhaps most convenient to develop them two at a time, a dish 10 in. by 8 in. being necessary for the purpose. It is the general practice to remove the plates from the dark-slides as they are exposed, placing them in a light-tight box known as plate-box (Fig. 157), until it is convenient to develop them. Another similar box may be used for unexposed plates, the two being suitably labelled to prevent mistakes.

THE DEVELOPING OPERATION.

The operator takes a couple of plates from the box and, giving them a tap on the bench to dislodge any dust that may have settled on them, places them, film side up, in the 10 in. by 8 in. dish. The film is easily recognised by its dull, creamy appearance, the glass side being bright and shiny. Four ounces of developer are then measured out from the glass jug, a 10-oz.

measure being used for the purpose, and poured with one sweep over the plates. The dish must be rocked at the same moment, so that the solution immediately covers both the plates. If this is done quickly and carefully, there will be no chance of the formation of air-bubbles on the film, or of part of the plate being left dry after the rest has commenced developing. The dish must now be gently rocked so that the solution flows regularly and evenly over the surface of the emulsion. An automatic rocker is a great convenience, enabling several dishes to be rocked

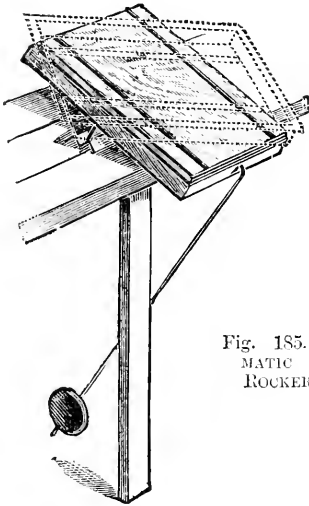

Fig. 185.—AUTO-
MATIC PLATE
ROCKER.

at the same time, or left unattended. A typical pattern is shown by Fig. 185. Some workers prefer to allow the dish to stand, but this is almost certain to result in flat, lifeless negatives, lacking in brilliancy. After a few seconds, the high lights will begin to appear as dark patches on the film, if the exposure has been correct; these are soon followed by the minor lights, the half-tones, and last of all by the detail in the shadows. The plate, however, must not be taken out directly it appears to be dark enough, since it will lose a good deal of strength in fixing. Development must be continued until the negative is nearly opaque, and the shadow portion is just beginning to veil. This is judged by holding the negative up in front of the

lamp (see Fig. 186). The light must be kept at a regular height, and the negative examined at a uniform distance from the lamp, or the results will be deceptive. The negative is then removed from the dish, rinsed lightly under the tap, and placed in a washing tank while the remaining negatives are developed. It is hardly likely that any two negatives will be finished at exactly the same moment; they are examined separately, and every time a plate is removed from the developer a fresh one is inserted from the box. When two plates have been developed, the solution is poured off and replaced by another 4 oz. of newly mixed developer from the jug.

WASHING THE PLATES.

When all the plates are developed, they are taken in turn from the washing tank and placed in the hypo.-dish, which is large enough to hold six or a dozen at once. They are left in this for twice as long as they take to become perfectly clear, generally about a quarter of an hour. As they are fixed, they are replaced in the washing tank, and, when all are ready, washed for one hour by allowing the water to run over them from the tap.

TREATING WRONGLY EXPOSED PLATES.

It occasionally happens, when developing on the above system, that a plate will turn out to be under- or over-exposed. Over-exposure makes itself evident by the flashing up of the image immediately on the application of the developer; it then quickly veils over. In such a case instant action is necessary. A half-plate dish containing a 10 per cent. solution of potassium bromide is kept ready, and the plate removed as quickly as possible to this, after a rapid rinsing under the tap. A new developer is made up, containing 2 parts of the No. 1 or pyro. solution, and only 1 part of No. 2, which contains the soda or accelerator; a few drops of bromide are also added. The plate is then removed from the bromide dish, and development completed with the more restrained mixture, another dish being used for the purpose. All this time, the remaining negative or

negatives in the 10 in. by 8 in. dish are carefully watched, or they will be over-developed. For under-exposure—indicated by the image being a long time in appearing and the slow emergence of detail—the plate is transferred to a dish containing a developer made up in the proportions of 2 parts of No. 1 to 1 part of No. 2; or (and this is in many cases a better plan) to a developer diluted with about four times its amount of water, and containing

the developer. This being ascertained, development is continued for a certain multiple of that time, when the plate is found to be of correct density. This is explained by the fact that development, with most reducing agents, proceeds in regular and definite proportion, the total time of development being always in exact relation to that taken by the first appearance of the image. Suppose, for instance, that metal is being used, and the image



Fig. 186.—DEVELOPING PLATES.

a larger quantity of soda. Prints from negatives of the same subject which have been correctly, under-, and over-exposed respectively, are shown in the full page plates.

TIME OR FACTORIAL DEVELOPMENT.

The factorial system of development was introduced by Mr. Alfred Watkins in 1893, and is already in high favour with many of the foremost photographic workers. It consists in noting the time occupied to produce the first appearance of the image, counting from the moment of pouring on

appears in 10 seconds. The developing factor of metal is 30; it is therefore necessary to continue development for thirty times 10 seconds—300 seconds or 5 minutes. At the end of that time the plate will be of correct density. Once the time of appearance is noted, the plate may be covered up and simply rocked till the necessary time has expired.

FACTORS OF DIFFERENT DEVELOPERS.

The developing factor is not the same with all developers, each reducing agent having its own particular factor. The

pyro.-and-ammonia developer is found to be unsuitable for treatment by this method, owing to the irregularity of action caused by the evaporation of the ammonia. Mr. Watkins gives the following factors for the various developers:—

Aduril ... 5	}	Hydroquinone ... 5
Amidol (2 grs. per oz.) 18		Imogen sulphite 6
Diamidophenol 60		Kachin ... 10
Diogen ... 12		Metol ... 30
Edinol ... 20		Ortol ... 10
Eikonogen ... 9		Pyrocatechin ... 10
Glycin ... 7		Rodinal ... 10

DEVELOPING FACTOR OF PYRO.

Pyro. is omitted from the above list, in order to consider it in greater detail. The



Fig 187.—WATKINS' EIKRONOMETER.

developing factor varies with the number of grains of pyro. per ounce of mixed developer, and also with the quantity of bromide used. The following table will enable the factor for any given pyro. developer to be readily calculated, provided the formula is known. It is assumed that soda or potash is employed as the alkali, ammonia being, as already stated, unsuitable for this method of development.

Grains of Pyro per oz.	Factor without Bromide.	Grains of Bromide. per oz.	Factor with Bromide.
1	18	$\frac{1}{4}$	9
2	12	$\frac{1}{2}$	5
3	10	$\frac{3}{4}$	$4\frac{1}{3}$
4	8	1	4
5	$6\frac{1}{2}$	2	3

THE FACTOR SIX.

It is very convenient to use a developer having 6 for its factor, as in this case it is only necessary to divide the time of appearance by 10 to obtain the number of

minutes, thus saving the necessity of dividing by 60. For example, if the time of appearance is 20 seconds, by the ordinary method the calculation would be $20 \times 6 = 120 \div 60 = 2$ minutes, whereas by the quicker method it is $20 \div 10 = 2$ minutes. Mr. Watkins gives the following formula for a pyro.-soda developer having the factor 6:—

PYRO. STOCK SOLUTION.

Dissolve $\frac{1}{4}$ oz. of potassium metabisulphite in 5 oz. of water. Pour this into a 1 oz. bottle of pyro., pour off into a 10-oz. measure, and make up with water to a bulk of 9 oz. 1 dram.

No. 1. Stock pyro.-solution	6 drs.
Water to make	10 oz.
No. 2. Sodium sulphite	$\frac{1}{2}$ oz.
Sodium carbonate	$\frac{1}{2}$ oz.
Potassium bromide	10 grs.
Water to make	10 oz.

For use, take equal parts of No. 1 and No. 2.

FACTOR OF A COMBINED DEVELOPER.

The factor of two developers used together will be practically equal to the average or mean of their constituents, provided that an equal quantity of each is used. For example, equal parts of hydroquinone (factor 5) and metol (factor 30) would have a factor of about $17\frac{1}{2}$. When the two developers are used in unequal quantities, the calculation is done somewhat differently. Thus with a mixture of 3 parts of metol to 2 parts of hydroquinone, the factor would be found as follows:—

$$\begin{aligned} \text{Metol (3 parts)} & 30 \times 3 = 90 \\ \text{Hydroquinone (2 parts)} & 5 \times 2 = 10 \\ 90 + 10 & = 100 \div 5 = 20, \text{ the required factor.} \end{aligned}$$

ADVANTAGES OF THE FACTORIAL METHOD.

The factorial system of development reduces what is often mere guesswork to a definite and exact method. For orthochromatic plates, in particular, it is invaluable, as they need hardly be exposed to the light of the dark-room lamp for more than a few seconds. Two prints are given on one of the full page plates as an

example of the remarkable uniformity of result obtained by this system. One received twelve seconds exposure, while the other was given as much as two minutes. They were both developed with ortol by the factorial method, and, as will be seen, yield practically identical prints, except that, as might be expected, the longer exposure shows rather more detail in the shadows. Of course, it is better for exposures to be more uniform than this, the ideal system obviously being the use of an exposure meter + time development. A special dark-room clock with a 10-minute dial and a slide-calculator, known as the Eikronometer, devised by Mr. Watkins to facilitate calculation in factorial development, is shown by Fig. 187.

STAND DEVELOPMENT.

It is possible to develop plates by prolonged immersion in a dilute developer. This is known as stand development, a grooved earthenware or glass tank similar to a washing tank being employed, with a cover to prevent the too rapid oxidation of the solution by exposure to the air. The method is recommended in cases of under-exposure, where the dilute developer seems to have the effect of bringing out all possible detail without the usual hardness. Pyro. is, generally speaking, unsuitable for stand development, a non-staining solution being essential. The developer may be diluted with from 10 to 15 times the usual amount of water, only it should be noted that the quantity of preservative (sodium sulphite or potassium metabisulphite) must be increased in proportion to the extent of dilution. Care should be taken that no air-bubbles settle on the plates, or transparent white spots will result. If any are noticed after the plates have been a few minutes in the tank, they should be removed by gently wiping with cotton-wool. With a little practice the solution may be adjusted to take an hour for development, or so diluted that the plates may be inserted overnight and taken out ready for fixing in the morning. A metol and hydroquinone developer has been recommended for the purpose; kachin and glycin also are very suitable.

TENTATIVE DEVELOPMENT.

The photographer may sometimes have a number of different exposures to develop, without knowing whether they are correctly, over-, or under-exposed. In that case it is advisable to adopt what is known as tentative or experimental development, commencing operations with a weak developer, and transferring the partly developed negatives to a solution suitably prepared in accordance with their observed behaviour in the first developer. An excellent method, suggested some years ago by Sir W. Abney, is to soak the exposed plate for five minutes or longer in a strong solution of the developing agent, with neutral sodium sulphite as a preservative, but without any alkali. On coming out of this, the plate is treated with an alkaline solution, and development continued for satisfactory density and detail. Another method more generally employed is to use a normal developer, but to start with only half the usual quantity of the alkali (or No. 2 solution), the remaining half being added by degrees if found necessary. Or development may be commenced with a very weak or dilute developer, acting very slowly until a thin phantom image has been obtained, when the plate is well washed and finished with normal or modified developer, as seems to be required; this is known as phantom development.

LOCAL DEVELOPMENT.

It is often necessary, where certain parts of a negative appear to be less exposed than the rest, to allow them to be longer under the action of the developing solution. There are various ways of doing this. The plate may be rinsed under the tap, and the developer applied with a piece of cotton-wool, a soft brush, or even the finger-tip, to the part or parts which require it. Sometimes it is desired to hold back the sky, so as to preserve the detail in the clouds, while continuing to develop the landscape portion of the negative. This may frequently be done by inclining the dish so that the solution acts more on the lower portion of the plate, or by rinsing when the sky is sufficiently dense, and

finishing as before described. Painting over certain parts with a strong solution of bromide will have the effect of holding them back; or glycerine may be mixed with the developer, and the latter applied in different strengths by means of a brush. Great care is required with all these methods, or the results will be patchy; they are, indeed, scarcely applicable for any but large negatives.

DEVELOPMENT OF WRONGLY EXPOSED PLATES.

Most of the remarks on tentative development apply also to the treatment of wrongly exposed plates, but a few additional hints may be given. If a plate flashes up suddenly in the developer, pour off the latter at once, and flood the plate with 10 per cent. bromide solution, in which it may remain while a fresh developer with less alkali and more bromide is made up. A very much under-exposed plate is practically hopeless, but a certain amount of under-exposure may be atoned for by adding more alkali to the developer. This should be done gradually, in small quantities at a time. It is, however, preferable to complete development in a dilute developer as before described.

LANTERN PLATES.

The same degree of density is not required in a lantern slide as for an ordinary negative. It must simply be a shade denser than would be needed to make a pleasing positive transparency. Much will, however, depend on the light to be used for projecting the slide on the sheet. For example, a denser deposit is required for a slide to be projected by the arc or limelight than that needed for use in an oil lantern. An orange light is more suitable than red, as it allows better judgment of the picture; while a canary yellow is perfectly safe for slow lantern plates. Almost any developer may be used, but more bromide should be added to preserve the purity of the lights. More than ordinary care must be taken not to scratch or abrade the film. This part of the subject will be treated more fully in a later section.

PROCESS AND PHOTO-MECHANICAL PLATES.

These plates are extremely slow, and require a liberal exposure. A strong developer should be used, with the object of securing the maximum brightness and hardness. Altogether apart from their special use, they are often employed by photographers for copying photographs and engravings, on account of the vigorous results obtainable. For this purpose, however, it is inadvisable to obtain too hard a negative, or the effect will be unduly chalky.

WET PLATES.

As already explained, the wet-collodion plate is sensitised by immersion in a solution of silver nitrate, and exposed while wet. It is developed immediately after exposure. The developer at first employed was pyrogallic acid, but ferrous-sulphate is now chiefly used for the purpose. The solution is made to flow over the plate like a varnish, and immediately the image is developed the plate is rinsed gently, and immersed in the hypo. solution or in cyanide of potassium. Some workers prefer to develop in a dish, in the ordinary way. The following is a good developer for collodion negatives:—

Ferrous sulphate	½ oz.
Acetic acid (glacial)	½ oz.
Alcohol	½ oz.
Water	10 oz.

FERROTYPES.

Ferrotypes are wet-collodion positives, and are treated in much the same way as negatives, except that the developer is always made to flow over the plate, development being so rapid that the use of a dish is impracticable. The solution employed is, however, slightly different. After development the metal plate is rinsed, and fixed in a bath of ½ oz. of potassium cyanide to 20 oz. of water. The formula for development is as follows:—

Ferrous sulphate	150 grs.
Acetic acid (glacial)	½ oz.
Nitric acid	5 minims
Alcohol	½ oz.
Water	10 oz.

After fixing, the plate is rinsed for a few minutes in water and dried over a spirit lamp.

AMERICAN DRY PLATES.

American dry plates are ready-sensitised ferrotype plates, and require no immersion in the silver bath. It is this class of plate which is used in the automatic machines. One of these, the "Quta," was illustrated

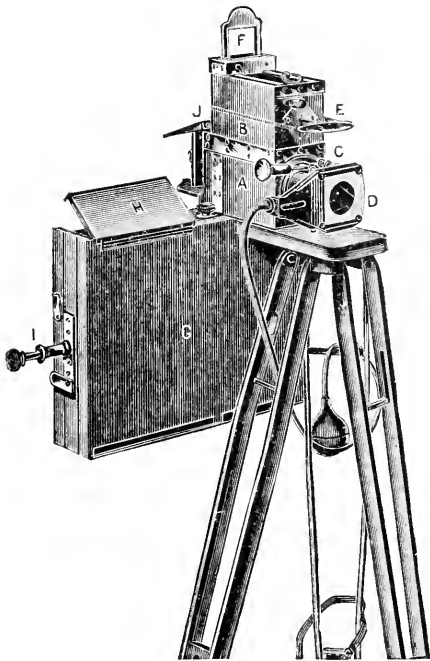

Fig. 188.—"TAKUQUICK" AUTOMATIC FERROTYPE CAMERA.

on p. 47; another, which is a great favourite with itinerant photographers, and is often met with at exhibitions, the "Takuquiek," is shown by Fig. 188. The following is a suitable developer:—

Warm water...	...	1 quart
Sodium carbonate	$\frac{1}{2}$ lb.
Sodium sulphite	$\frac{1}{4}$ lb.
Hydroquinone	$\frac{1}{2}$ oz.
Potassium bromide	100 grs.
Hypo-fixing solution	1 fluid oz.

First dissolve the carbonate and sulphite; then add the hydroquinone and bromide. When these thoroughly dissolved, add

the hypo. solution, and allow it to stand for a couple of days. The clear liquid is then decanted, and forms the developer. It will keep for months if well stoppered, and can be used repeatedly. It is better, however, to keep the old solution in a separate bottle. The fixing solution consists of 4 oz. of hypo. in 20 oz. of water. The time of exposure varies from half a second to about five seconds, or longer in dull weather. The developer is applied in the same way as with ordinary ferrotypes, and the plate carefully watched until the high lights and half lights are out and begin to blend. This will take from ten to twenty-five seconds, in moderately warm weather. The plate is then rinsed for a



Fig. 189.—SPOOL OF ENSIGN-VIDIL FILM.

few seconds, and plunged at once in the hypo. Fixing is complete in from ten to thirty seconds, according to the temperature. The plate is again rinsed for a few seconds, and dried over a gentle heat, after which it may, if desired, be varnished.

DEVELOPMENT OF FILMS.

Films are generally coated on a thin sheet of celluloid, and may be continuous, in which case they are known as roll films, or cut to the sizes of ordinary plates, when they are called flat films. As far as the operation of development goes, the solutions and treatment are the same for both plates and films; but they must be handled differently. The majority of roll films are now of the daylight description; that is to say, they are rolled up with a strip of opaque black paper in such a manner that a good length of the latter must be unrolled before the edge of the film is exposed. As a consequence, the rolls may be safely inserted or withdrawn from any camera made to fit them, without the necessity of going into a dark-room. The

Ensign-Vidil film possesses several distinctive features. The spool is provided with a spring clip which prevents the film from unwinding or becoming loose when not desired (see Fig. 189). The important departure, however, is that the film is not continuous but in sections, alternated with sections of a translucent paper. This arrangement enables focussing to be effected before each exposure, the translucent

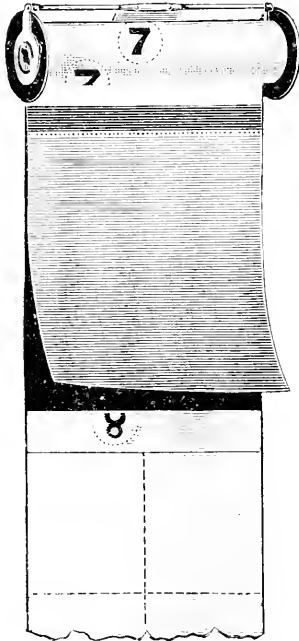

Fig. 190.—ARRANGEMENT OF ENSIGN-VIDIL FILM.

paper acting as a focussing screen. In addition, the films are perforated and may be removed individually for development without waiting till the entire spool is exposed. Fig. 190 shows the manner in which the film and focussing paper are alternated, the latter being provided with cross lines to assist in composing and leveling the picture. As a rule, films require rather more apparent density than glass plates, since the celluloid makes them appear more dense than is really the case, and greater care is required to avoid scratches and abrasions.

CUTTING FILMS.

Where the exposures are differently timed, it is better to cut the film and develop each section separately. The best way of doing this is to unroll the black paper until the film is reached. Take a couple of pins, and pin the end of the film and the black paper together to the edge of the bench, film side downward. The bench must be quite clean, and care should be taken that the paper and film are taut.

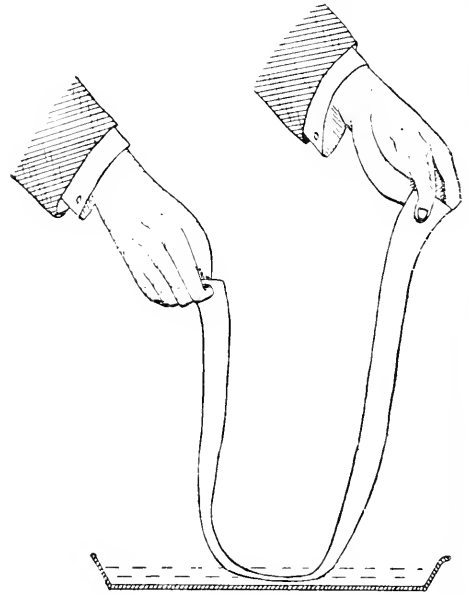

Fig. 191.—DEVELOPING LENGTH OF FILM.

The film is then unrolled, and, commencing at the end farthest from the fastened portion, cut into pieces with a pair of scissors, according to the marks on the back of the black paper. The films are next soaked in water, film side downward, for five minutes, after which they are developed in the ordinary manner in a rather deep dish, full of developer. Several may be developed at once, if care is taken to keep them in motion and to prevent them from sticking together. After fixing and washing, the films are soaked for one minute in glycerine $\frac{1}{2}$ oz., water 16 oz., and then pinned up by one corner to dry. The glycerine solution will prevent curling.

FILM IN ROLLS.

Where the exposures are known to be similar, the whole length of film may be developed at one operation, without cutting. This may be done by holding the film at each end, emulsion side downward, and allowing it to hang in a loop, as shown in Fig. 191. Both hands are then lowered, so that the film touches the developer; it is then drawn through the solution by raising and lowering the hands alternately, so that each part of the film is drawn in turn through the developer. After this has

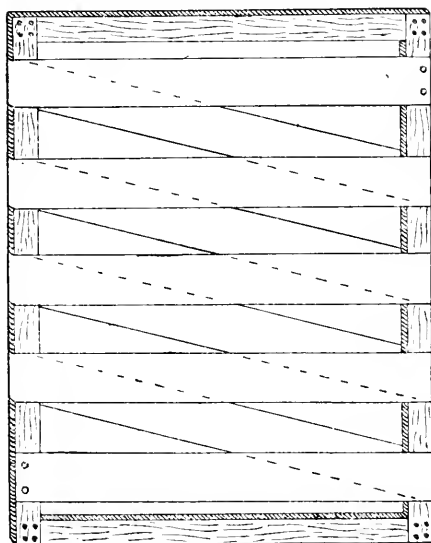

Fig. 192.—FRAME FOR WASHING LENGTH OF FILM.

been continued for about a minute, the film should be reversed, and the operation repeated with the celluloid side downward till development is complete. This method is adopted to prevent injury to the softened gelatine by contact with the sides of the dish. The film is rinsed and fixed in a similar manner. The washing may be done by pinning the film over a drum or a square frame, as shown by Fig. 192, and placing it under the tap in a large basin or tub. After washing, it is drawn through a glycerine bath, made as before, and hung up to dry, the ends being pinned to prevent curling.

SPECIAL APPLIANCES FOR DEVELOPING FILMS.

There are several ingenious contrivances intended to facilitate the development of films. Among these may be mentioned the

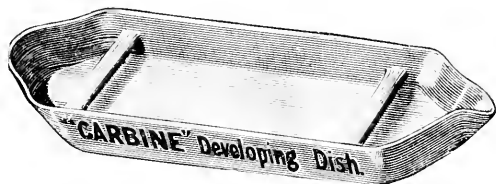

Fig. 193.—SPECIAL DISH FOR DEVELOPING FILM.

special form of dish shown by Fig. 193, in which the film is passed under the two bridges at each end, complete immersion in the developer thus being assured. Another device is shown by Fig. 194, where the film is drawn under a bent rod, carrying a revolving roller, which may be adjusted to any height to suit different depths

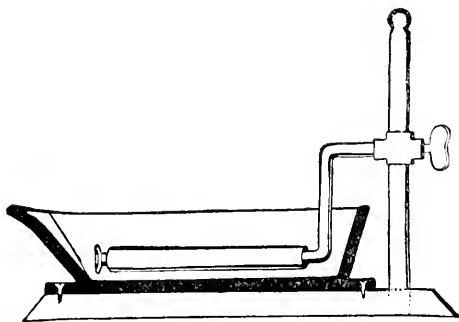

Fig. 194.—BENT ROD ARRANGEMENT FOR DEVELOPING FILMS.

of solution. There are also other devices for the purpose. One of these is in the form of a revolving drum, round the periphery of which the film is fastened, by the clips at A and B (Fig. 195), the drum being adjusted over the developing trough in such a manner that the bottom surface is immersed. By turning a handle the drum is revolved, and the whole film is passed through the solution. Fixing also is carried out with this appliance, and washing is accomplished by placing the

drum under the tap, first removing the trough (see Fig. 196). If desired, the film may be dried on the drum, by standing

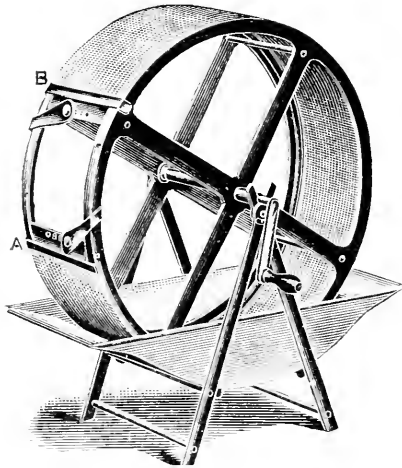

Fig. 195.—REVOLVING DRUM FOR DEVELOPING FILMS.

is fastened at one end and caused to revolve by alternately pulling and slackening the other end (Fig. 195). This arrangement is, of course, only suitable for development and fixing, the film being afterwards detached and washed by any of the usual methods.

DEVELOPING CINEMATOGRAPH FILMS.

The various contrivances mentioned above may be used for developing cinematograph films, particularly the wooden frame shown by Fig. 192, but the following plan is specially suitable for this purpose.

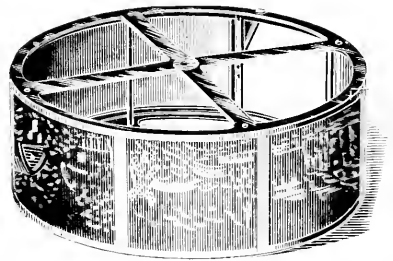

Fig. 197.—DRYING FILM ON DRUM.

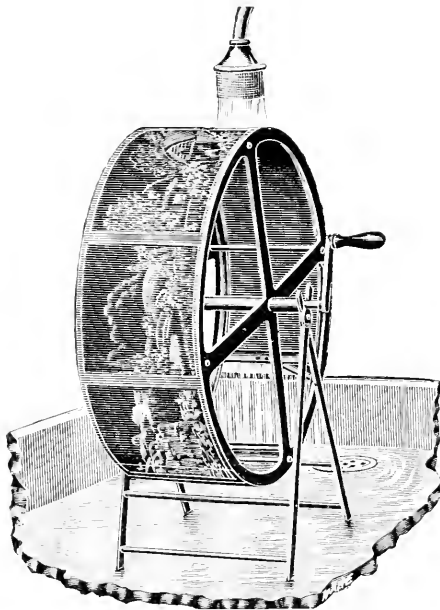

Fig. 196.—WASHING FILM ON DRUM.

the latter on one side, as in Fig. 197. Another excellent device consists of a small drum containing a spring. The film

A very long narrow wooden dish is employed, made waterproof by coating with enamel, melted paraffin wax, or japan black. The ends of the film are pinned down, and development, fixing, and washing carried out in the same dish. For washing, it is only necessary to place the dish in an inclined position under the tap, allowing the water to run from the top, as shown by Fig. 199. Another method is to have a deeper dish of half the length, furnished with a roller at each end, an outside handle being fixed to each roller. The film is carried over the roller, emulsion side outwards, and fastened together at the ends. By turning either handle the continuous film is drawn through the solution.

DEVELOPMENT OF CRISTOID FILMS.

The Sandell Cristoid Film possesses several special features. It is made up of two distinct layers of emulsion, of different speeds, and consists of gelatine alone without any support or base. The com-

combination of a slow and a rapid emulsion allows great latitude of exposure, and halation is almost impossible. The film may be obtained either in rolls or cut to any ordinary plate size. Before develop-

minutes, according to the temperature. In cold weather, the formalin bath is unnecessary. After hardening, the film is rinsed; and placed in the developer, being moved about in the same way as before.

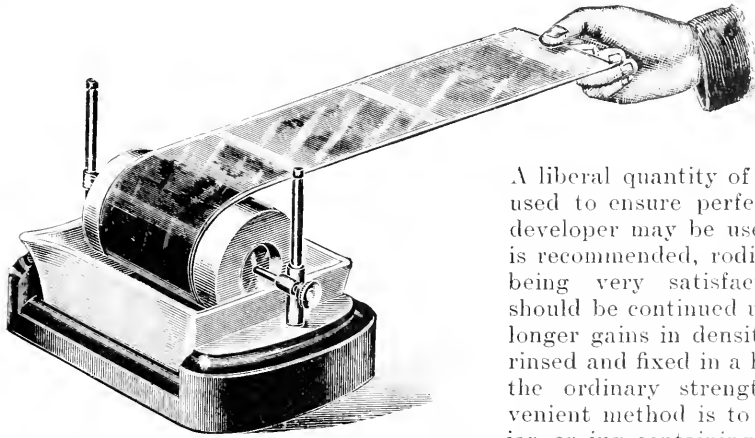

Fig. 198.—SPRING DRUM FOR DEVELOPING FILMS.

A liberal quantity of developer should be used to ensure perfect immersion. Any developer may be used, but pyrocatechin is recommended, rodinal and synthol also being very satisfactory. Development should be continued until the negative no longer gains in density. The film is then rinsed and fixed in a hypo. bath of double the ordinary strength. The most convenient method is to place the films in a jar or jug containing the fixing solution,

ment, the film is hardened in a formalin solution in the proportion of 2 oz. of formalin (Schering.) to 2 oz. of water. This may be used repeatedly, until it becomes too weak. The film should be unrolled, and folded across the dish from end to end, as shown by Fig. 200; taking care, however, that each part of the film is immersed before another portion is folded over it. Move the film about rapidly, so as to

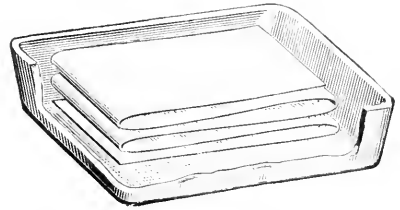

Fig. 200.—METHOD OF FOLDING CRISTOID FILM.

and to stir them up for a few seconds. Fixing will probably be complete in about two minutes, but the films should in no case be removed until perfectly free from

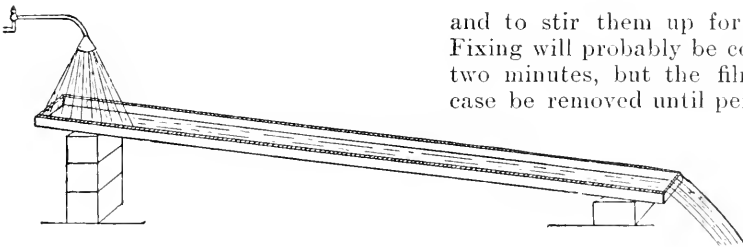

Fig. 199.—LONG DISH FOR CINEMATOGRAPH FILM.

ensure even action of the solution. If one fold is found to stick to another, pull it carefully apart, and keep circulating the film with the tips of the fingers, as shown by Fig. 201. The film should be taken out as soon as it becomes perfectly flexible, the time varying from one to three

white unfixed silver. They should be kept in the dark-room until this is accomplished, and are then washed as usual. The Cristoid film is a favourite with architectural workers, and in all cases where halation is likely to occur. The double film of different rapidities affords a re-

markable compensation for even extreme errors of exposure. It might be thought that the unsupported gelatine film would require great care in manipulation, but such is not by any means the case. After treatment with formalin as already directed, the film will be sufficiently hardened to stand any reasonable amount of handling.

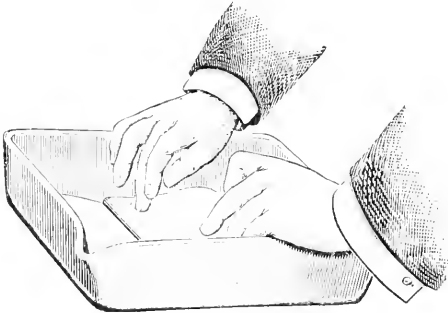

Fig. 201.—CIRCULATION OF CRISTOID FILM.

EXPANSION OF CRISTOID FILMS.

The Cristoid film has the property of expanding during development, as might be expected, considering the nature of

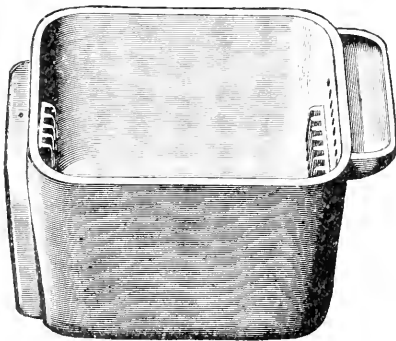

Fig. 202.—STONEWARE WASHING TANK.

gelatine. This may be considered an advantage by some, as it gives a larger negative. The films may, however, be restored to their original size by immersion in methylated spirit. This is done before drying, if necessary; otherwise the film is dried by squeezeing down to a per-

fectly clean piece of glass, ferrotype plate, or pulp slab. The negative side, which is darker, should be uppermost. In warm weather, the films should be treated with a glycerine bath before squeezeing, in the proportion of $\frac{1}{2}$ oz. of glycerine to 40 oz. of water. This may be used repeatedly. In any case, the film is left flat on the glass for a short time, and then stood up to dry in a suitable place. Care should be taken that no draught reaches it in the process of drying. When quite dry, a knife is passed under one edge, and the film carefully stripped off.

REMARKS ON FIXING.

The hypo.-solution should never be made up with cold water, or the temperature of the solution will fall to such an extent that

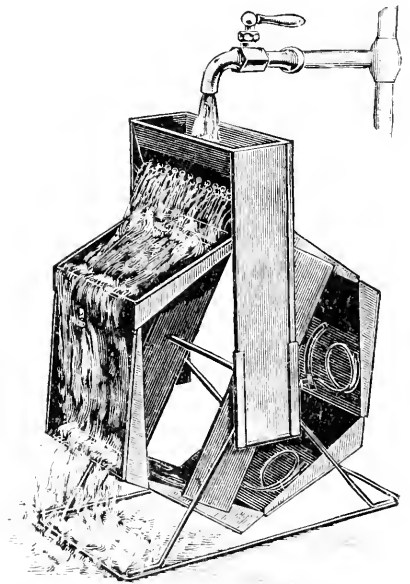

Fig. 203.—WHEEL DEVICE FOR WASHING PLATES.

fixing will be very slow and unsatisfactory. Hot water should always be used, and the solution allowed to become cold. It is a good plan to make a quantity at a time, keeping it in a large bottle, or in a stoneware jar with a tap. Some forms of the chemical arrangement known as an

aspirator are very well adapted for this purpose, with a little alteration. If this cannot be obtained, an ordinary 1-gallon beer jar may be made to serve the purpose. Hypo. solution may be used over and over again for plates, but it should be thrown away before it is much discoloured. The old solution may be preserved, if desired, in a large tub or barrel, with a view to the recovery of the dissolved silver. The trouble taken in recovering the silver will be amply repaid.

CLEARING SOLUTION FOR PLATES.

Sometimes, especially when developing with pyro., the plate becomes somewhat

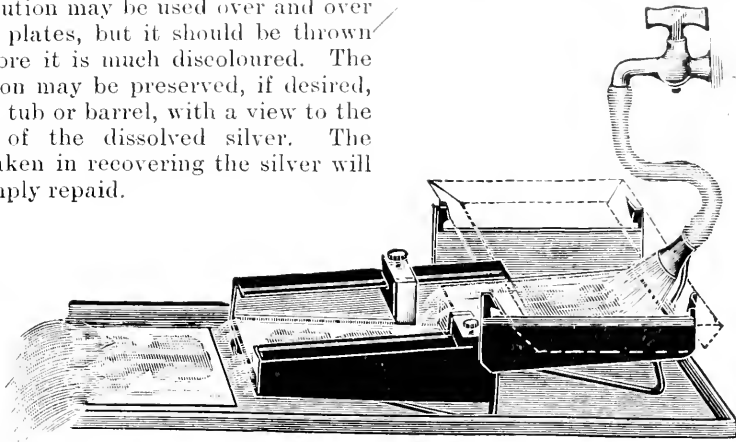

Fig. 204.—SPECIAL ROCKING ARRANGEMENT FOR WASHING PLATES.

stained, and a clearing bath may be desirable. Here is a good formula for this:

Alum	2 oz.
Citric acid	1 oz.
Water	10 oz.

Wash a few minutes after fixing, and immerse the negative in the solution. A formula especially successful in removing the yellow stain caused by prolonged pyro. development is:—

Saturated solution of alum	...	20 oz.
Hydrochloric acid...	...	1 oz.

This is used after fixing, first washing the negative for a few minutes. After clearing, the negative is allowed to wash for the usual time. With careful working, the clearing solution will seldom be needed, although some photographers make a practice of using it in every case.

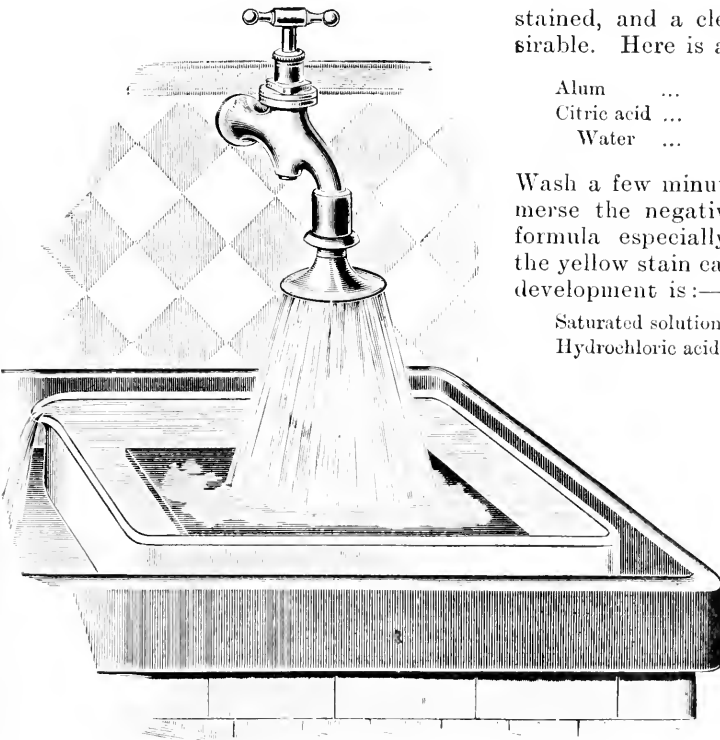

Fig 205.—ROSE AND FILTER ATTACHMENT FOR TAP.

IMPORTANCE OF THOROUGH WASHING.

It is necessary that every trace of hypo. should be removed from the gelatine film. To secure this, nothing is better than an hour's washing under the tap, the plates being stood up in a grooved tank. There are various patterns of tanks in use, one of

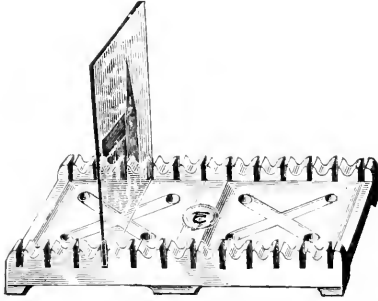

Fig. 206.—PORCELAIN DRYING RACK,

these being shown by Fig. 202, and another on p. 17. There are also several special contrivances intended to secure a more

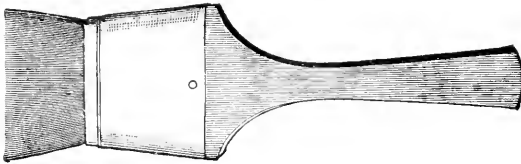

Fig. 207.—DUSTING BRUSH.



Fig. 208.—VELVET PAD FOR DUSTING NEGATIVES.

perfect and speedy removal of the dissolved hypo. An ingenious device, after the fashion of a water-wheel, is shown by Fig. 203. As will be seen, a negative is placed in each division and water directed through the opening at the top, causing the wheel to rotate under a steady spray. Another arrangement, which explains itself, is illustrated by Fig. 204. Large negatives are generally placed in a dish under the tap. A combined rose and filtering arrangement is now obtainable, to fit any tap, and is a great convenience for this and other photographic purposes (see Fig. 205). Films are best washed in a rather deep dish, emulsion side downward, if cut ;

while long strips may be treated as in development.

PRECAUTIONS IN DRYING.

Negatives are usually dried by standing them in a grooved wooden, metal, or porcelain rack. Patterns of these have been already illustrated. A porcelain rack (Fig. 206) is a useful acquisition, taking up very little room and being also available for washing, by standing it with the negatives in any suitable receptacle. Drying should take place in a fairly warm atmosphere, free from dust. It is the practice of some photographers, in fine weather, to stand the racks outside in the open air. This certainly promotes rapid drying, but dust and grit are apt to collect on the film. A good plan is to enclose the rack in a muslin or gauze cover, after the style of a meat-cooler ; this will effectually prevent the deposition of dust. A drying box on this principle is now obtainable, and is a great convenience. In doubtful or cold weather, the best place for the rack containing the plates is on the mantelshelf

over a fire. Negatives may be rapidly dried by draining off the surplus water, and immersing them for five minutes in methylated spirit. They are then drained, pressed lightly between two pieces of clean white blotting-paper, and placed near a current of air, or at a short distance from a fire, where they will dry in a surprisingly short time. When a negative is taken out of the washing tank, in any circumstances, it should be gently rubbed with a tuft of cotton-wool and rinsed under the tap, for the purpose of removing any surface deposit or grit which has collected on the film. This would be an objectionable feature when the negative was dry.

PINHOLES IN NEGATIVES.—DUST SPOTS.

The photographer is often troubled with transparent spots, having the appearance of minute holes, in the negative. These may be caused either by dust or by the settlement of air-bubbles on the film during development. It does occasionally happen that dust has reached the emulsion during manufacture, but such cases are very infrequent. Dust spots may generally be prevented by keeping the camera and slides perfectly clean, and

are sometimes beyond remedy. Rocking the dish will prevent air-bubbles settling on the film as a rule; if any obstinately cling to the negative, they should at once be removed by gently rubbing the fingers across it, or by means of a soft camel-hair brush. On no account should the plate be soaked in water before development; this simply tends to the creation of spots and air-bubbles, without any advantage whatever being gained. The film should not be touched with the fingers before development, as this often causes invisible grease

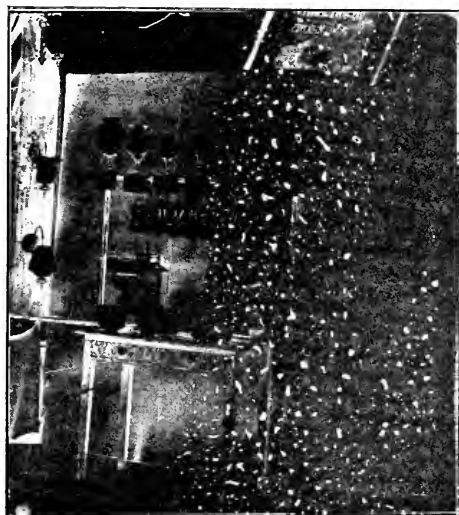

Fig. 209.—SPOTS DUE TO STALE DEVELOPER.

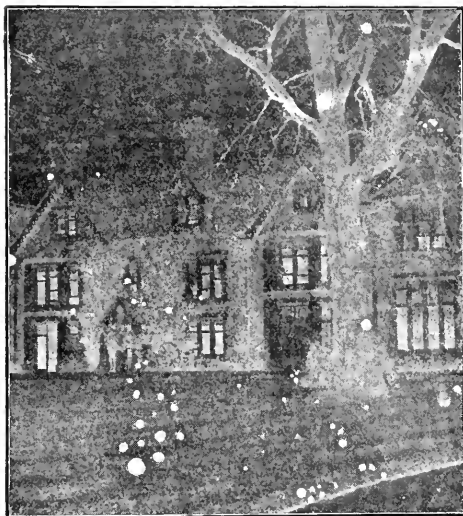

Fig. 210.—SPOTS CAUSED BY AIR-BUBBLES

dusting the plate before placing it in the slide and before development. This may be done with a camel-hair brush of the shape shown by Fig. 207, or a soft velvet dusting pad (Fig. 208). Another way which is quite as efficacious, and without the risks attending the use of a possibly dusty brush, is to tap the edge of the plate gently on the table or bench. This generally dislodges any adherent matter.

AIR-BUBBLES.

The holes caused by dust are, as a rule, easily spotted out with colour; those, however, caused by air-bubbles resting on the film and obstructing the action of the developer are far more troublesome, and

spots, which repel the developer and cause uneven action.

OTHER CAUSES.

Figs. 209 to 213, kindly lent by the Imperial Dry Plate Co., Ltd., afford interesting examples of the different effects produced by various errors of working. Fig. 209 shows a cloud of small spots running in a regular line or wave. This result is chiefly due to the use of a stale developer. The solution should not be allowed to stand in the measure, nor should it be used for more than one plate, except in those cases where the nature of the developer allows of this being done. Another variety of spots, due to the rest-

ing of air-bubbles on the film, is illustrated in Fig. 210. Fig. 211 shows white spots with small dark centres, due to minute portions of unfixd silver. The presence of these opaque spots is explained by the fact that the portion of film not reached by the developer has remained unsoftened, and so fixes more slowly, thus leaving tiny particles of unfixd silver in the middle of the spots. Figs. 212 and 213 show the result of uneven application of the developer. The negatives have not been properly covered with one sweep, and the

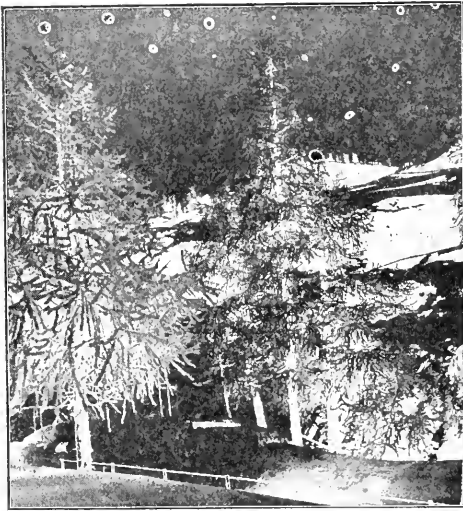

Fig. 211.—SPOTS WITH DARK CENTRES.

solution has acted on some parts of the negative sooner than on the others. To avoid this, a sufficient quantity of developer should be used, and it should be flowed with a rapid sweep over the plate.

DAYLIGHT DEVELOPMENT.

It is possible to develop plates without the use of a dark-room, (*a*) by staining the film to a non-actinic colour, (*b*) by staining the developer, or (*c*) by using a special contrivance known as a developing machine. In any case, the plate or film must be introduced into the staining solution, coloured developer, or machine under cover of a black cloth or changing bag. After this, the rest of the operation may go on

in full daylight. As an example of the first method may be mentioned the preparation sold under the name of Coxin. The plate is taken from the slide and immersed in this solution, under cover of a changing bag. The dish containing the plate and Coxin solution is then taken out, and placed on the bench. When the solution has been allowed sufficient time to stain the film, the plate is transferred quickly to the developer, which is placed ready in another dish. Development is carried out as usual, density being judged



Fig. 212.—UNEVEN ACTION OF DEVELOPER.

by looking at the surface of the plate. The red stain is removed from the negative by the final washing after fixing. The second method, that of staining the developer, serves a precisely similar purpose. Mr. Howard Farmer was one of the first to make practical use of this idea, although it is only lately that it has obtained such great popularity. Perhaps the best agent for the purpose is chrysolphite, a chemical compound introduced by the Lumière Company. It may be used instead of sodium sulphite in making up the developer, and serves all the purposes of the former salt, while affording the required stain. There are also other preparations on a similar principle.

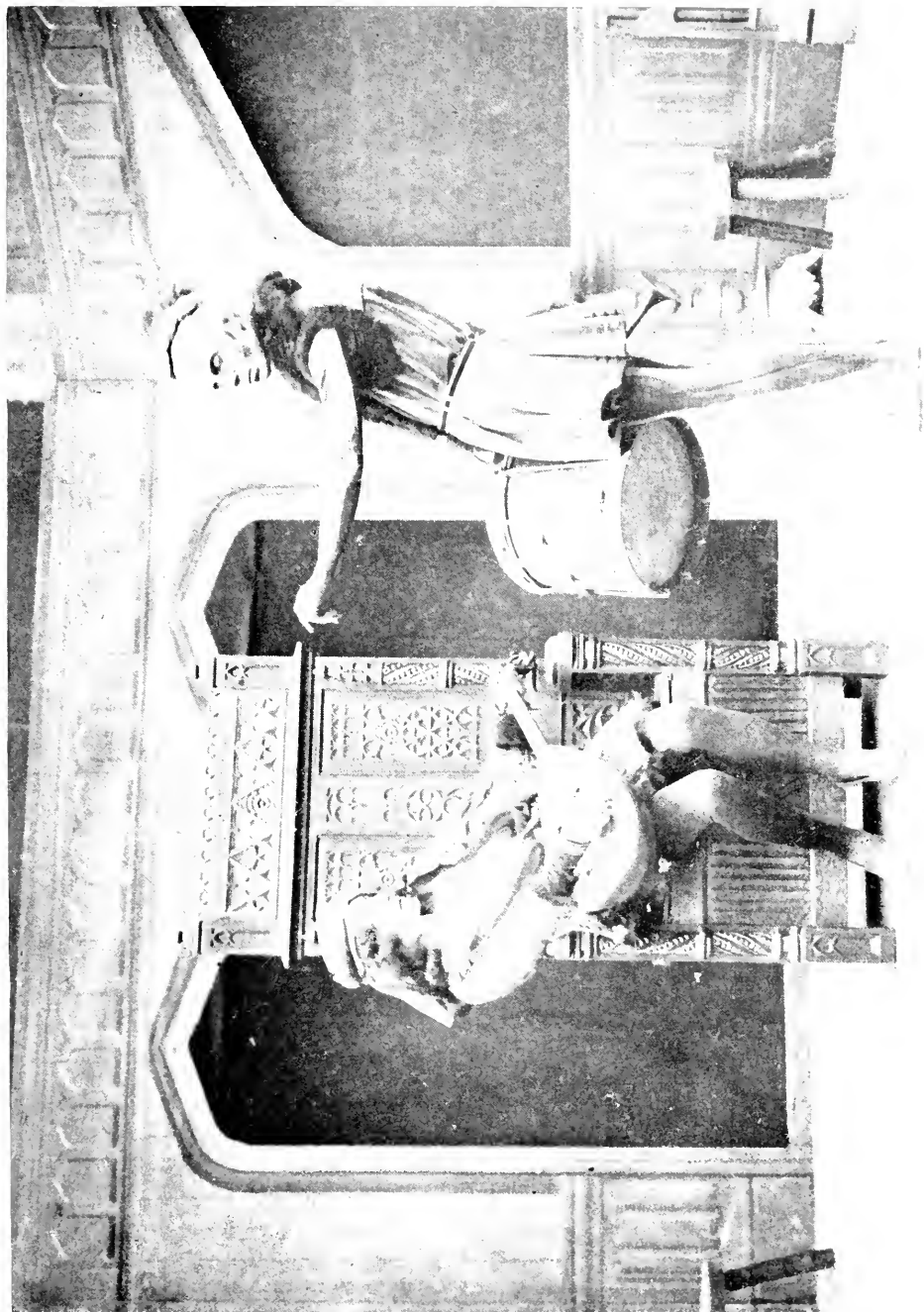

SPECIMEN OF PLATINOTYPE AFTER DEVELOPMENT

MACHINES FOR DEVELOPING.

The developing machine is simply a very small dark-room, in which the various solutions act automatically. Probably the best-known of these is the Kodak developing machine, shown by Fig. 214. This is intended for use with daylight films. The lid is removed, and the roll of film inserted in position; first, however, turning the handle A until the whole of the apron F is in compartment D (Fig. 215). When all is correctly adjusted, the developer is poured in, and the lid closed. By turning



Fig. 213.—PATCHES DUE TO UNEVEN ACTION.

the handle B, the whole length of film is gradually unrolled, from off the spool at C on to the roller G in compartment E, so that the solution has access to it, the film being ingeniously arranged in several layers separated by the celluloid apron or ribbon F with corrugated rubber bands at the edges. Development is continued for a given time, the solution being of a definite strength and temperature, when the developer is poured off and the fixing solution introduced. The Tyma developing trough (Fig. 216) is an excellent contrivance on the same principle, but possessing a funnel for pouring in the different solutions, as well as a syphon outlet. It is

thus possible to wash the film thoroughly without removal, a great advantage. The Quincey developing box (Fig. 217), for use with plates or films, or for both, allows development to be judged by means of a ruby eye-piece. The Pocket Dark-room (Fig. 218) is neat and compact, and may be carried in the pocket; it is available for plates or films, allows the progress of development to be judged, and needs only 1 oz. of developer each time.

DEVELOPMENT AFTER FIXING.

The plate is fixed in hypo. for about 10

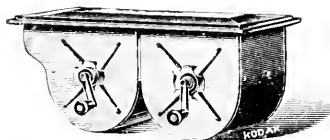

Fig. 214.—KODAK DEVELOPING MACHINE.

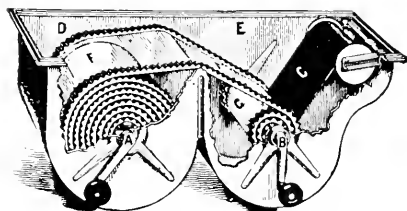

Fig. 215.—INTERIOR OF KODAK DEVELOPING MACHINE.

minutes, and may then be developed with the following stock solution:—

Silver nitrate	50 grs.
Ammonium sulphocyanide	120 grs.
Water	1 oz.

Dissolve the silver nitrate first, then add the sulphocyanide. A precipitate will be thrown down. A 20 per cent. solution of hypo. is next added, a drop at a time, until the precipitate again dissolves, taking care to add no more hypo. than is just sufficient to accomplish this. For use, take stock solution, $\frac{1}{2}$ oz.; sodium sulphite, 10 grs.; pyro., 3 grs.; ammonium bromide, 2 grs.; water, $\frac{1}{2}$ oz.; ammonia, 3 minims. At the end of two minutes, if there is no sign of

development, add another minim of ammonia; and if necessary repeat this, until the plate begins to develop. The operation may be carried out, once the plate is fixed, in weak gas-light or lamp-light. The negative should have received a liberal exposure, for the results to be satisfactory. The method is not recommended.

COMBINED DEVELOPMENT AND FIXING.

A suitable formula for this is:—

Sodium hyposulphite	1½ oz.
Potassium hydrate	200 grs.
Kachin	200 grs.
Sodium sulphite	2 oz.
Water	20 oz.

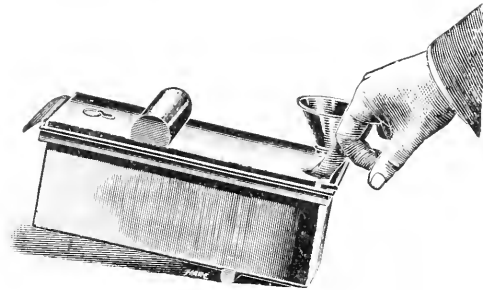

Fig. 216.—TYMA DEVELOPING TROUGH.

Development is completed at the time the plate is fixed, and the negative then simply requires the usual washing. It is necessary that the plate should have received a liberal exposure, and the operation must take place in the dark-room. The method, although interesting, is not recommended.

CONCLUDING HINTS ON DEVELOPING.

Keep all solutions well stoppered. Avoid contamination of one reagent with another. Endeavour to keep the dark-room at a uniform temperature, and the lamp at a uniform strength of illumination. Do not get impatient with a negative if it does not at once gain proper density; never place a plate in the fixing solution when there is any doubt about its being suffi-

ently dense. For ordinary work, aim at obtaining softness and detail, rather than

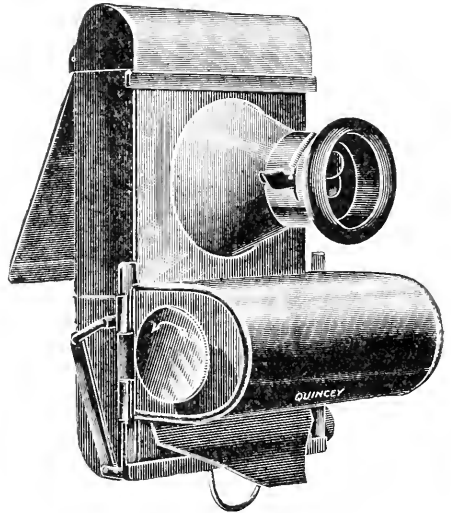

Fig. 217.—QUINCEY DEVELOPING BOX

vigorous contrast; but do not be satisfied with flat, weak results. Do not attempt to shorten the period of washing; let each negative have a full hour, unless there is



Fig. 218.—POCKET DARK-ROOM.

some special reason for haste. The secret of successful development is the exercise of care, patience, and deliberation.

INTENSIFICATION OF NEGATIVES.

MEANING OF THE TERM.

It frequently happens that a plate after fixing is of insufficient density, or, as it is sometimes expressed, "too thin." This may arise from removing the negative from the developer too soon, from under-exposure, or from over-exposure. In bad cases of under-exposure it is often impossible to obtain proper density, while over-exposure may lead to the production of a thin, flat negative, due to a certain amount of what is known as solarisation or reversal. It would be difficult to obtain a satisfactory print from such negatives, as a definite degree of density and contrast is required for successful printing by most of the ordinary processes. It is, however, possible to increase the density and contrast of thin negatives by treatment with various solutions, which add to the deposit on the film or convert it into a less transparent substance. This operation is known as intensification, and the solution used for the purpose is called an intensifier.

There are several methods of intensification with silver salts, of which the following are examples:—

FARMER'S PROCESS.—INTENSIFICATION WITH SILVER BROMIDE AND PYRO.

A.—Silver Nitrate	2 oz.
Water	20 oz.
B.—Potassium Bromide	1½ oz.
Water	4 oz.

Mix the two solutions thoroughly, and filter off the silver bromide precipitate; wash well and dissolve in a solution of hypo. 4 oz. in 12 oz. of water. For use take 1 drachm of the stock solution, add 2 oz. of water, 4 grains of pyro., 40 grains

of sodium sulphite, and 4 minims of ammonia.

INTENSIFICATION WITH SILVER BROMIDE AND FERROUS OXALATE.

A.—Silver Nitrate	½ oz.
Water	6 oz.
B.—Potassium Bromide	180 grs.
Water	2 oz.

Mix and filter off the precipitate, wash well and dissolve in a solution containing 1 oz. of hypo. in 8 oz. of water. Immerse the plate in the solution, wash for a few seconds, and redevelop in ferrous oxalate.

INTENSIFICATION WITH PERMANGANATE.

Dissolve 30 grains of potassium permanganate in 10 oz. of water. Allow this to act upon the plate for ten or twelve minutes, then remove to clean water for a few seconds; redevelop the plate with ferrous oxalate.

PHYSICAL AND CHEMICAL INTENSIFICATION.

There are many other ways by which a negative may be intensified. Two of these are physical; that is to say, they are due to some change in the structure of the gelatine film or of the silver image, rather than to any chemical reaction. One of these physical methods is by treating the film with alcohol or methylated spirit: the other consists in drying the wet negatives by the application of heat. The more generally used methods depend in principle on a chemical change in the composition of the image, which is converted into a more opaque substance. There are numerous formulæ for this purpose, the most popular probably being that known as the mercury and ammonia inten-

sifier. Mercury is also used with sodium sulphite and other salts. Uranium, silver nitrate, copper bromide, and lead ferricyanide are other useful intensifiers, and will be dealt with in due course.

INTENSIFICATION BY SPIRIT.

This method is convenient where no very great degree of additional density is desired, and serves the purpose of rapidly drying the negative at the same time. After the plate has received the usual amount of washing, it is stood up in a rack and allowed to drain for a few minutes. It is then immersed in a dish containing methylated spirit, where it is left for five or ten minutes. The plate is then taken out, the surplus spirit drained off, and the plate pressed gently between two sheets of clean white blotting-paper; it is finally placed in a rack at a short distance from a fire, or dried very cautiously near or over a spirit-lamp or gas-burner. The result will be a distinct increase in density. This method is not recommended for general work, as it seems sometimes to exert a flattening influence on the contrast, by, as it were, levelling-up the tones between the lights and half-tones.

INTENSIFICATION BY HEAT.

A negative developed with pyro. may be dried at the fire or over a lamp without injury, if care is taken not to allow the plate to get unreasonably hot and not to heat it too suddenly. A plate dried in this manner is rendered denser, the operation having an intensifying effect. This cannot be safely done with other than pyro.-developed negatives, as the gelatine film will probably melt and run. This method must be practised with great caution, as it is very easy to exceed the amount of heat which may safely be applied. The chemical methods of intensification are much to be preferred to either of those just mentioned, which are more curious and interesting than practically useful.

NATURE OF THE CHEMICAL CHANGES.

The silver image of a negative may be given additional density by various chemical processes. These may be divided into

three classes: those which involve the deposition of extra silver on the image, those which depend on the substitution of a more opaque substance for the whole or part of the silver in the image, and those which simply change the colour of the silver or alter its molecular structure. It must be remembered that, in any case, intensification will not bring out anything except what is already on the plate. It will only make stronger and more forcible what is really there. Unless the plate has sufficient detail visible, it is useless to attempt to intensify it; while if any degree of fog is present, the negative should be reduced to clear this away, or intensification will make matters worse.

INTENSIFICATION WITH MERCURY.

The mercurial intensifier is by far the most generally used, and is probably the simplest and best. It consists in principle of adding to the negative a deposit of metallic mercury, or of some mercurial compound, of proportional gradation to that of the existing silver image. One of the full page plates shows a print of an under-exposed, thin negative, the left half of which has been intensified with mercury, the improvement being very striking. It is important that the negative should be well washed after fixing, and every trace of hypo. removed, or stains will result. Some workers prefer also to immerse the negative in a strong alum bath for about ten minutes, and again wash thoroughly. This certainly keeps the gelatine film in better condition, but is not absolutely necessary. The negative having been well washed, it is next placed in the following bleaching solution:—

Mercuric chloride	½ oz.
Hydrochloric acid	45 minims
Water	10 oz.

It should be mentioned that mercuric chloride, or bichloride of mercury, is a violent poison, and requires the greatest care in handling, especially if there are any cuts on the fingers or hands.

BLEACHING THE NEGATIVE.

Shortly after being placed in the bleaching solution, the negative will commence

to whiten. The subsequent amount of intensification depends on the extent to which this bleaching is carried. The dish should be rocked occasionally, and the negative examined at intervals by holding it up to the light. No attention need be paid to the colour, which will be altered afterwards, but simply to the gradual gain in strength or density, remembering that the negative will be rather denser when dry than it appears in a wet state. If the negative does not require much intensification, a short immersion will suffice; while if it is very weak, the bleaching should be carried on until the whole of the film appears white when looked at from the back. The negative is then well washed, and, after gentle wiping with a tuft of cotton-wool, is ready for the blackening.

BLACKENING THE NEGATIVE.

There are many ways of blackening the negative after bleaching with mercury. Perhaps the most popular of these is by the use of a weak solution of ammonia, viz :

Liquor ammoniæ (88°)	1 oz.
Water	20 oz.

The plate is placed in this, and allowed to remain until the image has changed from white to a deep brown; by increasing the strength of the ammonia a blacker tone will be obtained. It is then thoroughly washed and dried as usual. If the intensification should be insufficient, the negative may again be bleached with mercury and blackened as before. This is, however, seldom necessary. If the intensification is excessive, it may be reduced, after washing, by placing in a clean solution of weak hypo.

REGULATING THE DEGREE OF INTENSIFICATION.

A certain amount of modification is possible by varying the strength of the two solutions. A weaker mercury bath may be used where very slight additional density is needed. Another method of control consists of bleaching the negative till it appears white all over from the back, and regulating the blackening by using a stronger or weaker ammonia bath. These devices are, however, rather uncertain;

and it is preferable to work with solutions of a constant strength, obtaining the desired result by varying the length of immersion in the mercury. The latter solution may be used repeatedly, but tends to become weaker by frequent use.

FACTORS TO BE CONSIDERED.

As already stated, the time of immersion in the intensifying solution depends both on the character of the negative and on the kind of result desired. The character of the negative depends on the amount of density it already possesses, the amount of contrast contained in the subject, the scale of gradation, and other considerations. It would be absurd, for instance, to seek the same amount of intensification for a delicate landscape as would be required for a strongly-lighted piece of statuary. Another factor which must be taken into account is the nature of the printing process for which the negative is intended. One prepared for printing in platinotype or carbon, for example, will require greater density and contrast than would be suitable for P.O.P. The kind of print in hand must be kept constantly in mind during each operation, the negative being simple a means to an end.

BLACKENING WITH SODIUM SULPHITE.

There are other ways of blackening the negative, besides using ammonia, after bleaching with mercuric chloride. Among these, sodium sulphite is to be recommended, as working very cleanly, and not tending to clog up the details of the negative, as ammonia sometimes does. It does not, however, give quite the same degree of density as the latter, being more suitable where only a slight intensification is desired. The solution used is:

Sodium sulphite	2 oz.
Water	10 oz.

Some workers prefer to use double the quantity of water, and to acidulate the solution by the addition of 10 minims of acetic acid to each ounce of the mixture. As with ammonia, the bleaching and darkening may be repeated if desired, thoroughly washing between each operation.

Only a slight rinsing between bleaching and blackening will suffice when the blackening agent used is sodium sulphite, and for this reason it is sometimes chosen when the negative has to be produced speedily, as there is little or no chance of staining by this method.

BLACKENING BY REDEVELOPMENT.

Yet another method of blackening the film is that known as redevelopment. This consists simply of treating the negative, after bleaching with mercury and well washing, with a developing solution, just as if it were an exposed plate. The operation is carried out in daylight, and the developer allowed to act until the bleached film is completely blackened. Any developer may be used, but ferrous-oxalate appears to be the most suitable; pyro. also will give very satisfactory density. If the former is employed, the clearing bath must not be omitted. A developer which has been already used is perfectly suitable for intensifying, so long as there is any strength left in it. As with the processes previously mentioned, the entire operation may be repeated, a fresh gain of density occurring each time, but not to the same extent as at first.

MONCKHOVEN'S INTENSIFIER.

By this method a mixture of mercury and silver is deposited on the original image, giving an excellent black colour. Two solutions are required, both of which, it should be noted, are highly poisonous, the potassium cyanide being one of the deadliest poisons known.

No. 1.—Mercuric chloride	...	50 grs.
Potassium bromide	...	50 grs.
Water	5 oz.
No. 2.—Silver nitrate	...	50 grs.
Potassium cyanide	...	50 grs.
Water	5 oz.

In making up No. 2, the water should be divided into equal portions, the cyanide being dissolved in one and the silver nitrate in the other. The cyanide solution is then poured into the dissolved silver nitrate, well shaking the mixture. A white precipitate will be formed, which will gradually become almost but not quite redis-

solved. If it should become quite redissolved, add a drop or two of silver nitrate solution, until a slight precipitate is again formed. The solution should then be filtered. The negative is immersed in the No. 1 solution until it is bleached, the extent of which will depend, as usual, on the amount of intensification desired. It is then washed for about a quarter of an hour, when it is placed in No. 2 solution until the image is blackened through to the back. The plate must not be left in the cyanide too long, or a gradual reduction of density will take place. The plate is then thoroughly washed. The operation may be repeated if the first intensification is insufficient. A negative treated by this method looks slightly denser while wet than when dry, and this must be borne in mind. If the negative is found to be too dense, it may be reduced with a solution of about 1 oz. of hypo. to 20 oz. of water.

URANIUM INTENSIFIER.

It is rather more difficult to judge the probable effect of this intensifier, for the colour of the negative is changed gradually to a brownish red, which, of course, has a greater effect in printing than might appear from simple inspection. For this reason, uranium is unpopular with many workers. There are various formulæ, but they all contain uranium nitrate and potassium ferricyanide. The following is as good as any:

Uranium nitrate	12 grs.
Potassium ferricyanide	15 grs.
Water	4 oz.

The solution does not keep very well, and should therefore be mixed as required. Potassium ferricyanide, it may be mentioned, is highly poisonous. The negative should not be allowed to become actually red, but should be removed while in a brown state, or it will take a long time to print. After intensification, the negative is washed gently for not longer than will suffice to remove the greasy, streaky effect from the film—from ten to fifteen minutes. A prolonged washing will entirely remove the intensification—a fact worth noting, in case the negative has been made too dense. Dilute ammonia or other alkalies also will

remove the uranium ferricyanide, and may, if desired, be applied with a brush in parts only, where it is wished to strengthen the shadow locally. Where the intensification is not allowed to go very far, uranium has the effect of increasing the density of the shadows in greater proportion than the lights. Before using this intensifier, the negative must be thoroughly well washed, as the slightest trace of hypo. will cause stains or red fog.

LEAD FERRICYANIDE INTENSIFIER.

The negative is well and thoroughly washed, and placed in the following solution :

Lead nitrate	40 grs.
Potassium ferricyanide	60 grs.
Water	2 oz.

After this, the negative is again well washed, until a few drops of water drained from the plate give a scarcely perceptible blue tint when allowed to drop into a small test-tube containing a solution of ferrous sulphate. When this condition is obtained, the following sulphide solution is poured over the plate :

Ammonium sulphide..	$\frac{1}{2}$ oz.
Water	5 oz.

This method of intensification is very satisfactory, but possesses no advantage over those previously mentioned, while the necessity of testing the washing water is certainly an additional trouble.

MERCURIC IODIDE INTENSIFIER.

This formula is suggested by Lumière, and is in some respects an improvement on the ordinary system of mercurial intensification. The negative is first intensified in the mercuric iodide solution given below, and then treated with an ordinary alkaline developer (an old developer is preferable).

Sodium sulphite (anhydrous)	1 oz.
Mercuric iodide	44 grs.
Water	10 oz.

The sodium sulphite must first be completely dissolved, and then the mercuric iodide added, well shaking till completely mixed.

COPPER BROMIDE INTENSIFIER.

For this intensifier two solutions are made up :

No. 1.—Cupric sulphate...	120 grs.
Water	5 oz.
No. 2.—Potassium bromide	90 grs.
Water...	5 oz.

Mix them, and allow to stand for a few hours ; then pour off the clear solution, allowing the sediment (potassium sulphate) to remain behind, and afterwards throwing it away. The decanted solution is then ready for use. The negative is immersed in this until thoroughly bleached. It is then well washed, and blackened by a weak solution of ammonia, or by any ordinary developer, finally giving the plate a thorough washing. If the intensification is unsatisfactory, the negative may again be bleached, and blackened or redeveloped. The copper bromide solution may be used repeatedly, and will keep indefinitely. An old used developer is very suitable for blackening, provided it is not entirely exhausted.

INTENSIFICATION WITHOUT BLACKENING.

A negative which has been bleached in mercury may be printed from, and gives an increase of density somewhere between the spirit method and the sulphite. With the silver intensifier, only one operation is necessary, the negative assuming correct density in the solution and simply requiring washing. The sole drawback to the process is that, besides being rather tedious, it is distinctly expensive. The following stock solution, known as Wellington's silver intensifier, will keep indefinitely if stored in the dark :

Silver nitrate	60 grs.
Ammonium sulphocyanide	120 grs.
Water (distilled)	$2\frac{1}{2}$ oz.

Dissolve the silver nitrate in half the water. The sulphocyanide is then added, the mixture well shaken, and the remaining water introduced. When required for use, the bottle is shaken and a sufficient quantity of the solution poured into a glass measure. The solution being rather costly, it should be used sparingly, only just enough being taken to cover the plate ; half an ounce will suffice for a half-plate if a flat dish is used. To the solution in the glass measure add gently, and by degrees, a freshly made hypo. solution, stirring con-

stantly, until the milkiness at first present disappears and the liquid becomes clear. No more than sufficient hypo. to secure this result must be added. To each ounce of the mixture, 3 grs. of pyrogallic acid (previously dissolved or from a stock pyro. solution), 5 minims of ammonia (850°), and 1 gr. of ammonium bromide are added. The solution is then poured quickly over the negative, which is allowed to remain until sufficiently dense, making allowance for the fact that it will be a good deal more opaque when dry. If the intensifier seems to act too slowly, a drop or two more of ammonia may be added. Do not, however, add so much as to cause the solution to turn muddy, or it will have to be thrown away. When the negative is sufficiently dense, it is placed in a dish of fresh hypo. for about a minute, and then washed thoroughly. If the film becomes tender an alum bath may be used after the plate has been washed for about ten minutes; it is then given a final washing.

OTHER METHODS OF INTENSIFICATION.

A weak solution of ammonium sulphide applied to a negative has an intensifying action, by converting the image into silver sulphide, which is more opaque than the original deposit. Another method, which acts by causing the molecules of silver in the film to assume a coarser and denser character, is to bleach the negative by means of an acid solution of potassium bichromate, well wash, and redevelop with ferrous oxalate or hydroquinone. These methods, however, offer no advantages over those previously described.

INTENSIFICATION BY SUPERPOSITION.

A method suggested by Mr. A. Lockett in 1898 is useful where it is not desired to risk spoiling the negative. This consists in making a transparency from the thin negative on a photo-mechanical plate, aiming to get the brightest possible result. From this transparency two or three thin negatives are made on flat celluloid films, these being finally placed in perfect register, and bound together round the edges. The result, if carefully done, is a new negative of good printing density, without

any necessity of touching the original. This method is, however, only suitable for exceptional cases, being rather too troublesome for general use.

INTENSIFICATION OF WET COLLODION PLATES.

Should intensification prove to be necessary, it should be decided whether it is better to do this before or after fixing. If over-exposed, it is better to do it after; if under-exposed, before. There are various formulæ for intensification, of which the following system of redevelopment is the most suitable. Either No. 1 or No. 2 solution may be used.

No. 1.—Pyrogallic acid	7 grs.
Citric acid	10 grs.
Water	35 oz.
No. 2.—Ferrous sulphate	160 grs.
Citric acid	320 grs.
Water	35 oz.

Immediately before application to the film, a few drops of silver nitrate solution must be added to the developer:

Silver nitrate	160 grs.
Water	9 oz.

This method of intensification may be used either before or after fixing. When intensifying after fixing, a little iodine solution should be flowed over the film, which is then exposed to light, and afterwards treated with the pyro. solution given above. The iodine solution is made up of:

Iodine	1½ grs.
Potassium iodide	3 grs.
Water	2 oz.

ANOTHER METHOD,

for adoption after fixing, is to treat the negative with the iodine solution as above. This quickly changes the image to a bluish-green tint, which is less actinic than the original deposit. If this is not sufficient, flood the plate with:

Potassium permanganate...	...	25 grs.
Water	...	2 oz.

Yet another method, giving great density, is to bleach the film with a saturated solution of mercuric chloride, and when bleached to apply:

Ammonium sulphide	...	2 oz.
Water	...	35 oz.

This gives an intense black deposit of excellent printing quality. Dilute ammonium hydrate may, if desired, be employed in place of the sulphide. The following formula met with much favour at one time:

- No. 1.—Mercuric chloride ... 4 grs.
Water 25 oz.
- No. 2.—Potassium iodide ... 16 grs.
Water 2 oz.

Add No. 2 to No. 1, until the red precipitate of mercuric iodide is just dissolved.

SCHLIPPE'S SALT

(sodium sulph-antimoniate, Na_2SSbS_4) was once a good deal used for intensifying wet collodion plates. The iodine solution was first flowed over the plate, as already described, and the plate was then flooded with a solution of Schlippe's salt, a scarlet deposit being produced. This method, introduced by Mr. Carey Lea, is somewhat complicated and troublesome.

EXPOSURE OF UNFIXED COLLODION FILM.

There has been a good deal of discussion as to whether the unfixed collodion film may safely be exposed to light, when intensification is done before fixing. This depends to a great extent on the nature of the sensitiser employed in the film. An iodised film may be exposed to a tolerably bright light without danger, a bromo-iodised film requires more caution, while a bromised film is better kept from the light altogether till after the fixing operation. In intensifying after fixing there is some danger of producing a reddish stain in the shadows of the negative. This can generally be removed, however, with a little dilute acetic acid.

INTENSIFICATION OF DRY COLLODION PLATES.

For this purpose a 3-grain-per-oz. solution of pyrogallie acid is perhaps the best. To each ounce of pyro. add from 15 to 25 minims of the silver nitrate solution given

below, and apply the mixture until satisfactory density is gained.

- Silver nitrate 30 grs.
- Citric acid 15 grs.
- Nitric acid 15 minims.
- Water 1 oz.

INTENSIFICATION OF FOGGED NEGATIVES.

When a gelatine negative is at all fogged, it should not be intensified until the fog has been removed, or the latter as well as the image will be rendered stronger, thus making matters worse than before. The correct procedure is to reduce the negative slightly with a weak ferricyanide and hypo. solution, as described in the following section, well wash, and then intensify. Dichroic or colour fog, if slight, may often be removed by rubbing gently with a tuft of cotton-wool dipped in methylated spirit or alcohol, or by the ferricyanide reducer. These matters, however, will be treated at greater length when reduction comes to be considered.

CONCLUDING REMARKS ON INTENSIFICATION.

Intensification and its antithesis, reduction, while of great value when really necessary, should if possible be avoided. It is far better to aim at expertness in giving the exact exposure needed by the plate under any possible conditions of subject and lighting, and in judging exactly when the negative has attained correct density in the developer. Intensification is not a perfect process, and one cannot be sure but that the negative may be spoiled. Nor is the degree of additional density under such perfect control as might be wished. The tone values and gradation of an excellent negative may sometimes be quite falsified by unsatisfactory intensification, although the latter can generally be removed by treatment with hypo. Still, it must be admitted that intensification is often unavoidable, and if due care is given to the different operations, and special attention paid to thoroughness of washing after treatment with each solution, there need be no anxiety as to the result.

REDUCTION OF NEGATIVES.

WHY REDUCING IS NECESSARY.

Too much density in a negative, as a rule, is the result of over-development. This is, however, sometimes inevitable, owing to the shadows of the negative not being sufficiently brought out by the time the rest of the plate is finished. The consequence is that the lights are hard and opaque, and not only take too long to print, but are not in correct tonal value or gradation in relation to the rest of the picture. The shadows print to full depth, and, if not shielded, become black and clogged up, before the lights will allow their buried detail to print. This is objectionable in any case, but especially so in portraiture, where softness and delicacy are required. Such a negative can only be made to give a satisfactory print in one way—that is, by reduction. There is far greater necessity for the reduction of over-dense negatives than for the intensification of thin ones. The latter may often be made to print well by pasting tissue paper over the frame, matt varnishing, or printing in a weak light; but the over-dense negative resists all attempts at “dodging.”

DIFFERENT KINDS OF REDUCERS.

As in the case of intensifiers, reducers may be divided into two classes, the physical and the chemical. The former includes the various methods in which the silver image may be reduced in density by friction or rubbing; and the latter may be subdivided, according to their different action, into those which act more upon the shadows than upon the lights of the negative, those which affect both equally,

and those which reduce the lights to the greatest extent, having but little effect on the shadows. The photographer is fortunate in having so happily balanced a choice, for over-density in negatives is not always amenable to the same treatment. A hard, chalky negative, for instance, requires reduction of the lights only, for the shadows are probably already too thin; a negative which has been over-exposed and developed to too great a density will be best treated by reducing the shadows more than the lights; while one which has simply been over-developed, and in which the contrasts are otherwise about right, requires an equal reduction all over. Of the various reducing agents available, the ferricyanide reducer has a greater effect on the shadows, and ammonium persulphate on the lights; while the remaining formulæ may be chiefly placed among those which affect all parts of the negative in due proportion.

PHYSICAL REDUCING AGENTS.

Physical or mechanical reducers are chiefly of value when only certain parts of the negative require to be reduced. Among these may be named methylated spirit or alcohol, which is applied with a piece of soft wash-leather placed over the finger, or with an artist's leather stump. The leather or stump is slightly moistened with the spirit, and carefully worked over the parts to be reduced. This must be continued patiently, and without too heavy a pressure, until the desired effect is obtained. The negative, of course, must be dry. A little powdered chalk or very fine pumice-powder may be used in addition,

this enabling the work to be done more quickly. Great care should be taken, however, that the powder does not scratch the negative. This method is specially useful for bringing out the clouds from an over-dense sky, obtaining detail in white dresses, etc. A softening effect on the contrast may be produced by rubbing the negative, which must be perfectly dry, with fine pumice-powder, applied with a circular motion by the palm of the hand, until the film has a matt or ground-glass surface. It is possible, also, to work on the roughened film with pencil or stump to any desired extent.

BASKETT'S REDUCER.

This reducer, introduced by Mr. R. H. Baskett, is also of the mechanical order, and extremely effective. It is composed of:

Salad oil	1 oz.
Terebene... ..	$\frac{1}{2}$ oz.
"Globe" polish	a ld. tin.

The ingredients are thoroughly mixed, and strained through muslin into a stoppered bottle. When required for use, a little is taken on a silk rag or piece of wash-leather, and rubbed on the part to be reduced. The terebene may be omitted, if desired, but has a useful hardening action on the film, and gives also a pleasing polish. This latter property renders the reducer very well adapted for giving a fine surface to bromide and other prints, where the shadow detail appears buried. For this purpose it is simply rubbed gently over the print with a soft rag. The terebene required is that used by house painters as a dryer; terebene is a spirit, and unsuitable for the purpose. Baskett's reducer is an invaluable agent for local reduction, especially in the case of skies where the clouds are buried, or in dense portions of architectural negatives. It should be understood that friction is the sole principle of this reducer, and that care and judgment are necessary to use it successfully.

FERRICYANIDE REDUCER.

The ferricyanide reducer was introduced by Mr. Howard Farmer, and is perhaps

the one most used for general work. As already stated, it tends to reduce the shadows of the negative in greater proportion than the lights. It is therefore a valuable agent in all cases of fog, flatness due to over-exposure, and other kinds of deficient contrast. It may be employed for either general or partial reduction, and is made up as follows:

No. 1.—Potassium ferricyanide ...	20 grs.
Water	1 oz.
No. 2.—Sodium thiosulphate (hypo)...	1 oz.
Water	20 oz.

The hypo. solution must be clean and fresh; it will not do to take it from an old fixing bath. If dry, the negative is immersed in the hypo. until well soaked; otherwise, the reduction may be proceeded with at once. A few drops of the ferricyanide solution are poured into a glass measure; then the hypo. is poured off the negative into the measure, allowing the two solutions to mix. The mixture is afterwards poured back over the plate. Reduction immediately commences, and proceeds gradually. Take care not to use too much ferricyanide, or the solution may be too energetic. Progress should be carefully watched, and the moment the negative is sufficiently reduced it should be removed from the solution and washed thoroughly. The negative should be taken out while still a trifle too dense, as reduction will continue slightly during washing. What is left in the dish may be thrown away, for this reducer will not keep, and requires to be mixed fresh each time. If the solution does not work quickly enough, add more ferricyanide. Avoid using too much, however, or it will cause a yellow stain. When a strong solution is to be employed, or when the negative has to be kept in it for a long time, it is advisable to render the bath alkaline with ammonia, which will prevent yellowing of the negative. The ferricyanide is poisonous, and must be used with care. Both the salt and its solution keep better in the dark.

FERRIC CHLORIDE REDUCERS.

If only slight reduction is required, the negative is washed for a few minutes after

fixing, and immersed for one minute in the following solution:

Ferric chloride	1 dr.
Hydrochloric acid	2 drs.
Water	10 oz.

It is then washed and immersed in the hypo. bath. If a greater amount of reduction is necessary, the negative is merely rinsed after fixing and placed in the ferric chloride solution, which with the hypo. forms an energetic reducer. The amount of reduction is dependent upon the length of immersion in the ferric chloride solution and upon the strength of same. It is quite possible to reduce an extremely dense negative to a mere shadow by allowing the negative to well bleach in the iron perchloride and then to transfer it without washing to the hypo. bath, which should be freshly mixed and thrown away after use. Another method, introduced by Sir W. Abney, is very efficacious for removing colour fog. The negative is first bleached in the following solution:

Ferric chloride	100 grs.
Potassium bromide	60 grs.
Water	8 oz.

It is then well washed and redeveloped with ferrous-oxalate, the whole operation being performed in daylight. The result is to convert the green fog into an almost invisible grey deposit, which will not affect printing.

POTASSIUM CYANIDE.

With this agent the reduction is gradual, and well under control. It is made up of:

Potassium cyanide... ..	20 grs.
Potassium iodide	10 grs.
Mercuric chloride	10 grs.
Water	10 oz.

When sufficiently reduced, the negative is thoroughly washed. It should not be forgotten that potassium cyanide and mercuric chloride are deadly poisons. The method is chiefly used for local reduction, when it may be applied with a tuft of cotton wool or a Buckle brush. The addition of a few drops of bromine water has been suggested.

EAU DE JAVELLE.

This reducer acts by converting a part of the silver image into chloride, which is afterwards removed by an ordinary hypo. fixing bath. It is made up as follows:

No. 1.—Chloride of lime	2 oz.
Water	30 oz.
No. 2.—Potassium carbonate	4 oz.
Water	10 oz.

The two solutions are well mixed, and boiled. A precipitate of chalk will be formed, which must be removed by filtering. The clear liquid is the reducer, and is used in the proportion of 1 oz. of Eau de Javelle to 4 oz. of water. When sufficiently reduced, the plate is rinsed and placed in the hypo. bath till the silver chloride is dissolved out; and is finally well washed. A variation of this reducer is Labarraque's solution, which is made in the same manner, except that sodium carbonate is substituted for potassium carbonate. The chloride of lime referred to is that commonly sold as bleaching powder. Another method of making Eau de Javelle is to pass a current of chlorine gas into a dilute solution of caustic potash. Eau de Javelle is a mixture of chloride and hypochlorite of potassium, Labarraque's solution forming an identical compound of sodium. Both reducers should, theoretically at any rate, exert a perfectly uniform action on both the lights and the shadows of the negative.

AMMONIUM PERSULPHATE.

This is an extremely valuable reducer, on account of its property of reducing the lights of the negative more than the shadows. It is made up into a 2 per cent. solution:

Ammonium persulphate	1 part.
Water	50 parts.

For harsher negatives it may be used as strong as 4 per cent., but it is not advisable to go beyond this. The negative, after being well washed, is immersed in the persulphate solution. If it has been dried, it is better to soak it in water before immersion. When the reduction is considered sufficient, the negative is transferred

to a 10 per cent. solution of sodium sulphite to stop the reducing action, which would otherwise continue in the washing water. After two minutes in the sulphite bath, it is well washed as usual. The persulphate solution should be used fresh each time, or stains and patches are liable to occur. The salt appears to possess the property of eliminating any traces of hypo. which may remain in the film through imperfect washing after fixing; but in any case, a thorough washing is advisable. Ammonium persulphate can hardly be surpassed as a ready means for improving harsh negatives. It exerts a remarkable effect on the dense lights, while having scarcely any action on the shadows.

POTASSIUM PERMANGANATE.

The permanganate reducer, suggested by Professor R. Namias, of Florence, is also excellent for the reduction of harsh contrasts. A suitable formula is:

Potassium permanganate ...	8 grs.
Sulphuric acid... ..	16 minims.
Water	35 oz.

The negative should be washed, but does not require to be absolutely free from hypo. When immersed in the permanganate solution, the dish must be continually rocked, until the reduction is sufficient. If the film assumes a brown colour, the stain may be removed by a 1 per cent. solution of oxalic acid. After reduction, or after treatment with oxalic acid, if this proves to be necessary, the negative is well washed. The permanganate solution cannot be used more than once. It has the further advantage of eliminating any hypo. and salts left in the film.

POTASSIUM IODIDE AND HYPO.

This reducer is intended for use where extremely slow action is desired. A 25 per cent. solution of hypo. is prepared, and to 100 parts of this is added 1 part of potassium iodide. Reduction is very slow, and the action is clean and even. The negative may remain immersed for from one to ten hours with perfect safety, since the bath has a slight hardening action on the gelatine. This reducer is well adapted for the removal of fog.

BELITZSKI'S REDUCER.

The reducer introduced by L. Belitzski is much favoured by some workers. It is made as follows:

Potassium ferric oxalate... ..	176 grs.
Sodium sulphite	452 grs.
Water	8 oz.

When this is thoroughly dissolved, from 41 to 52 grs. of oxalic acid crystals are

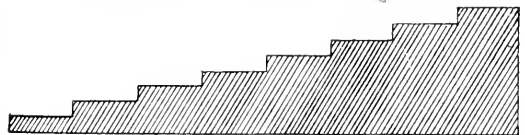

219.—GRADATION OF IDEAL NEGATIVE.

added, the solution being well shaken until it turns green. The liquid is then decanted, the undissolved crystals being left behind, and afterwards 1½ oz. of hypo. are added to it.

EFFECT OF AN IDEAL REDUCER.

It must be borne in mind throughout all negative work that the negative is only a means to an end, and therefore when an ideal reducer is spoken of this depends upon the class of negative to be dealt with and the result desired. The action of an

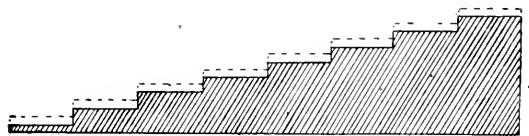

220.—ACTION OF IDEAL REDUCER.

ideal reducer, according to some workers, would be to remove an exactly proportional amount of silver from all the different gradations of the negative. Fig. 219 is intended to represent the various degrees of light and shade in a negative which is slightly too dense all over. As a matter of fact, this is a condition which rarely obtains, the lights always tending to be denser in proportion than the shadows; but the example will serve for the purposes of illustration. The action of such a reducer, then, should be equal on all parts of the negative, producing the result shown by Fig. 220, where the portions

removed are indicated by dotted lines. It will be interesting, therefore, to compare the action of two reducing agents of opposite properties in the same manner.

ACTION OF FERRICYANIDE AND PERSULPHATE COMPARED.

The ferricyanide reducer and ammonium persulphate are chosen for the purpose of this comparison, as presenting the most instructive differences. A negative of greater contrast than Fig. 219 will be more suitable, such as that shown by Fig. 221.

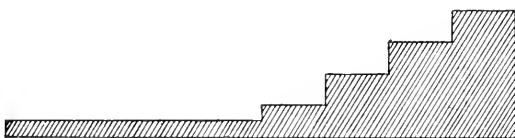

221.—NEGATIVE OF STEEP GRADATION.

As already noted, the ferricyanide reducer attacks the shadows in greater degree than the lights. The result is shown in Fig. 222, where the contrast of the negative has simply been increased, although the general density has been reduced. It is this property of attacking the shadows most which makes the ferricyanide reducer of great value for the improvement of negatives which are both dense and lacking in

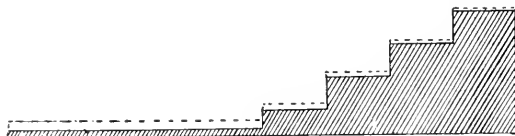

222.—ACTION OF FERRICYANIDE REDUCER.

contrast. Ammonium persulphate, on the other hand, has a directly opposite effect. It reduces the lights or denser parts of the negative much more than the shadows, having a flattening effect on the contrast (see Fig. 223). It should therefore be used for hard, chalky negatives, and in any case where the light and shade require softening. Between the two extremes offered by the ferricyanide and the persulphate reducers, the various other reducing agents may be regarded as intermediate, some inclining one way and some the other.

POTASSIUM BICHROMATE

has been recommended as a satisfactory reducing agent which does not necessitate long washing afterwards. A saturated solution of potassium bichromate is necessary, the reducer being made up as follows:

Potassium bichromate solution	15 minims.
Sulphuric acid	15 minims.
Water	2 oz.

This is diluted with water according to the degree of reduction considered necessary. It should be used very weak at first, and strengthened as required. The negative is washed for a short time after reduction.

HADDON'S REDUCER

consists of potassium ferricyanide and

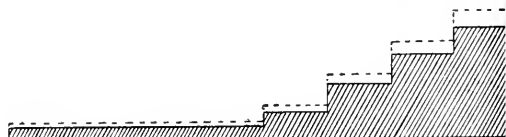

223.—ACTION OF PERSULPHATE REDUCER.

ammonium sulphocyanide, and is composed as follows:

Potassium ferricyanide	10 grs.
Ammonium sulphocyanide	20 grs.
Water	2 oz.

This solution has the merit of keeping well, which is more than can be said of some other reducers. The negative requires only a short washing after use. The plate is immersed in the solution in the usual manner, and allowed to remain until reduction is sufficient. A dry negative should be thoroughly soaked in water before immersion; it is advisable to rock the dish during the operation.

USE OF CLEARING AND FIXING SOLUTIONS AS REDUCERS.

Most clearing solutions effect a certain amount of reduction in the negative, if it is allowed to remain for a long time, and they may be used for this purpose when only a slight amount of reduction is required. The practice is, however, not recommended, as it is work for which the

clearing bath was never intended, and for which it is not really suitable. Prolonging the time of immersion in the fixing solution also has a slight reducing effect. This proceeding is less objectionable, but it should be noted that if left in too long the negative is liable to acquire a pronounced yellow stain. It must also be remembered that a longer immersion in the hypo. adds to the time necessary for washing.

LOCAL REDUCTION.

It frequently happens that a negative of satisfactory density and gradation has one or two obtrusive patches of light which would be better away. This is often the case in landscape photographs, where patches of sky showing through the trees are sometimes rendered as glaring white spots. Or perhaps a window, or other brightly lit part in an interior, is too conspicuous as compared with its surroundings. In such cases the remedy is to apply a reducing solution to those parts only which require it. This is known as local reduction. The negative is placed on a retouching desk, inclined as little as possible so that the solution shall not run, and the reducer applied with a brush or a small tuft of cotton-wool. A weak solution, used sparingly, is preferable; and great care should be taken that it does not spread where not required. The negative may be either wet or dry. If wet, the surface moisture should first be removed by pressing between two sheets of clean white blotting-paper. The reducer may be prevented from making sharp outlines by softening these with another brush slightly moistened with clean water. Softer results are probably obtained when the negative is wet, but the work is more easily judged on the dry negative. Any reducer may be used, but ammonium persulphate is recommended. Reduction should be immediately stopped, when sufficient, by immersing the negative in a 10 per cent. solution of sodium sulphite.

DESK FOR LOCAL REDUCTION.

Although an ordinary retouching desk is quite suitable for the purpose, a special desk on which the negative may be kept

in a horizontal position is decidedly an improvement. Such a desk, provided with a sheet of ground glass to diffuse the light

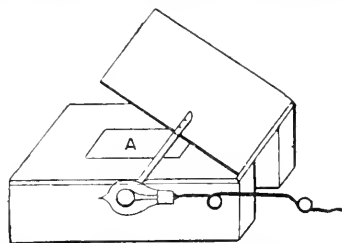

Fig. 224.—DESK FOR LOCAL REDUCTION AND INTENSIFICATION.

and suitable for use with electricity, is shown by Fig. 224. If preferred, the desk may be made a little higher, and a mirror inserted at an angle of 45° below the ground glass, the back being removed. The arrangement may then be used with either daylight or any ordinary artificial light. Local intensification may, of course, be done in the same manner, simply changing the solution.

REDUCTION BY EXPANSION.

When a gelatine film is stripped from the glass by means of hydrofluoric acid or other agent, it expands more or less in the water. This expansion is equal in all directions, and results in an enlargement of the film, which may be floated on to another glass of suitable size and dried in its enlarged condition. Various methods of doing this will be described later; the enlargement necessarily effects a reduction in the density of the image, by spreading the silver over a larger area. In a similar way, the stripped film may be made smaller instead of larger, by treatment with formalin followed by alcohol, or in a lesser degree by the use of methylated spirit. In this case, the image is intensified.

REDUCTION OF FOGGED NEGATIVES.

When fog is present in a negative that is also too thin, the best treatment is to use the ferricyanide reducer for the removal of the fog, afterwards well washing and then intensifying. The ferricyanide should not be very strong, and the negative should not be immersed for longer than is found

necessary to clear it. For the removal of dichroic or colour fog, Abney's ferric chloride formula is recommended, as given on p. 140. A little retouching medium on a soft silk rag, applied with gentle friction, is frequently efficacious, or methylated spirit may be used. These, however, are of use only when the dichroic fog is merely a surface deposit.

REDUCTION AND TONE VALUES.

It has been shown that the gradation of a negative may be greatly altered both by reduction and by intensification. The effectiveness of a picture depends largely on correct gradation and tonality. Atmospheric effect and chiaroscuro often constitute the principal charm of a monochrome, therefore every precaution should be taken against falsifying the gradations of the negative. Whenever reduction or intensification is found to be necessary, careful attention should be paid to the special result desired, and a deliberate choice made of what is seen to be the most suitable agent for obtaining that result.

CONCLUDING REMARKS ON REDUCTION.

There is rather more risk in the process of reduction than in that of intensification, and greater care is therefore necessary on the part of the operator. If a negative is over-intensified, it can, as a rule, be brought back to its former condition; but a negative which has been reduced too much is practically spoilt. It may still be intensified, it is true, but the original beauty of gradation cannot be restored. It is for this reason, probably, that many workers will have nothing to do with reduction; and would rather put up with negatives which take a week to print, or which are decidedly chalky and hard, than run the gauntlet of possible dangers. This, however, is going to the other extreme. With ordinary care, and a proper consideration of the effect desired and the correct method of obtaining it, almost any difficulty may be successfully overcome. Finally it must be understood that the choice of a reducer must be governed by the character of the existing negative, and the contrast and gradation desired in the

resultant print. There are four distinct types of negative which may require reducing: (*a*) Those correctly exposed and developed but with shadows fogged. (*b*) Those correctly exposed but developed too far, giving too brilliant contrast. (*c*) Those correctly developed but under-exposed, resulting in a hard effect; the negative having dense high lights and wanting in detail. (*d*) Those over-exposed and over-developed. Obviously a method which would be suitable for one of these would be unsuitable for another, for whereas in *a* and *d* the contrasts need increasing, in *b* and *c* the contrasts need decreasing. In *a* and *d* the shadows need reducing most; in *c* the lights need reducing most; whilst in *b* the contrasts will be sufficiently reduced by a reduction all over the negative in the same proportion to the deposits in each part. For suppose the densities of lights, shadows and half tones of a negative to be represented by figures 2—4—6, and a density equal to 1 be subtracted, then they become 1—3—5; so that, although an equal amount has been taken from each, the shadows have really suffered most as they had least to spare; and consequently, the half tones are now three times as dense and high lights five times, instead of twice and three times as before. It is probably due to a misunderstanding on this point which has led to such contradictory statements as to the effect of various reducers. Photomicrographs of deposits before and after reduction seem to indicate that the lower particles are first attacked by the ammonium persulphate and consequently most reduced, whilst a comparison of results of the action of various reducers upon a graduated set of deposits of known density is exceedingly interesting and an easy experiment to perform. A thorough soaking of the negative before the reducer is poured over tends to a more even reduction in the case of ammonium persulphate. Negatives answering to the description of *a* should be reduced by the ferricyanide and hypo. bath; those like *b* and *c* in ammonium persulphate; and those like *d* in ferric chloride or either of the other reducers described.



FIVE MINUTES' EXPOSURE.

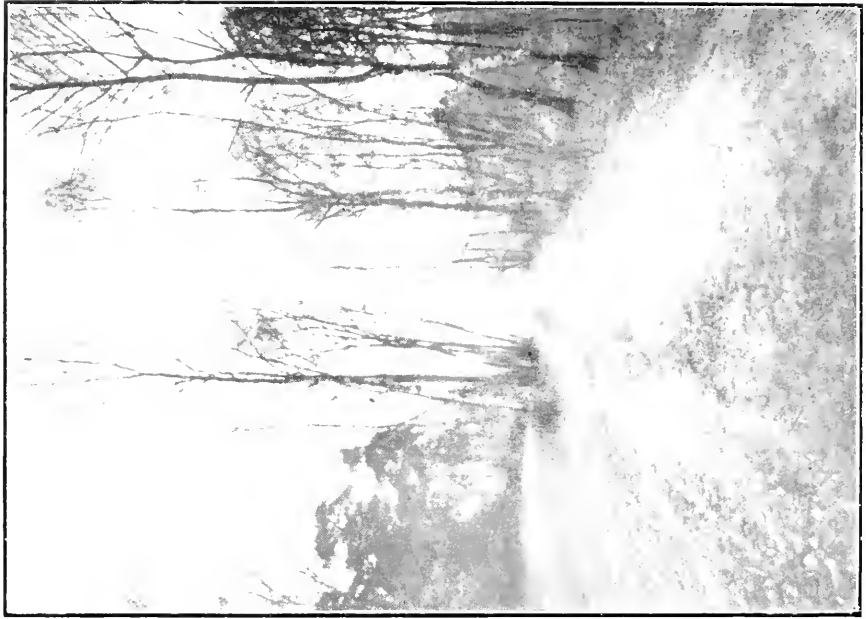

EIGHT MINUTES' EXPOSURE.

EXAMPLES OF PINHOLE PHOTOGRAPHY

PREPARING THE NEGATIVE FOR PRINTING.

RETOUCHING DEFINED.

RETOUCHING consists in improving the picture to the greatest possible extent without losing the character or likeness, these qualities being even strengthened if the work is done skilfully. Every portrait negative requires a little retouching, and it is the only really successful method of remedying freckles and wrinkles. The art is much abused not only by those who for want of practical knowledge declare all retouching unnecessary, but by those who, lacking either technical skill or artistic feeling, retouch a negative or a print until it becomes a new picture. Retouching, legitimately used, consists in the removal of mechanical defects and exaggerations. The qualifications of a retoucher include artistic feeling, a good grasp of drawing and anatomy, and a knowledge of photography generally.

MATERIALS USED IN RETOUCHING.

The tools and materials necessary are three retouching holders with movable leads (Nos. 1, 2, and 3), a No. 2 sable brush, a small bottle of matt varnish, 1 oz. of alcohol, a cake of erimson lake, some ivory black, a sand-paper block, a few paper stumps, a sheet of tracing-paper, and a very sharp knife. Retouching medium may be bought ready prepared, or it is easily made by dissolving half a teaspoonful of finely powdered resin in 1 oz. of turpentine. Ordinary resin dissolved in turpentine is quite satisfactory both as regards "tooth" and freedom from disturbance when varnishing. The exact consistency of the medium depends

entirely on the artist's touch. It should never be so thick as to be tacky in printing. Workers with a light touch who use a soft pencil prefer the medium in a sort of thin syrup which, rubbed vigorously over the negative, imparts a polished surface. Others prefer a thinner medium, and for them a good one is pale resin 1 part, oil of lavender 2 parts, and oil of turpentine 1 part



Fig. 225.—RETOUCHING KNIFE.

THE RETOUCHER'S KNIFE.

The successful reduction of a negative by cutting or scraping depends very much upon the condition of the film and on the proper handling of the knife. The knife must have an extremely sharp edge, but slightly turned. The handle of the knife must be neither heavy nor long, and just before use the knife should be well sharpened on a fine whetstone without lubricant, giving rather more weight to one side of the blade than to the other. The exact form of the knife is not of much importance, but Fig. 225 shows a good pattern. An ordinary ink scraper answers well, and is easily sharpened by laying it flat on the stone. Small cutting nibs which may be inserted in a pen-holder are obtainable for trimming prints. These make very effective retouching knives (see Fig. 226). Points essential to success in using the knife are that the film should be bone dry and the light good.

HOW TO USE THE KNIFE.

Shadows may be deepened in a negative, and opaque (or light) lines removed by scraping with the sharp knife just described. The negative must be thoroughly dry and slightly warmed, or the film may tear. A much better light is necessary for the use of the retoucher's knife than for pencil work. For this work remove the ground glass from the desk. Scrape only the least possible amount at each stroke, producing a slight scraping sound ;

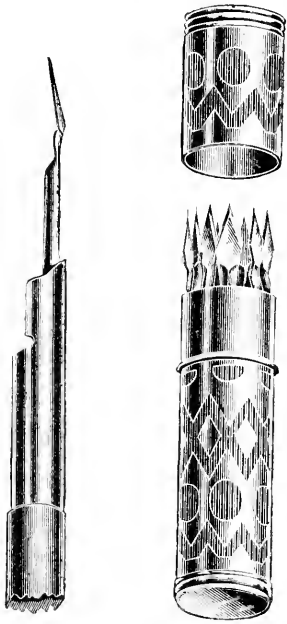

Fig. 226.—CUTTING NIBS SUITABLE FOR RETOUCHING.

the effect should not be visible till after a few strokes. On no account go right through the film, as so deep a shade will never be required, and if the film is entirely scraped away there is nothing to work upon. View the effect of the work from all angles by turning the negative round. For thin lines the point may be used, but for broader spaces use the edge of the blade. If the knife is inclined to tear, it should be sharpened.

THE RETOUCHING DESK.

The retouching desk is shown by Fig. 227. For those who have to do the work at night, a sheet of tin or iron, bent as shown in Fig. 228, should be attached by means of the pins and holes x x to the top of the desk, to protect it from the heat of the lamp. Failing the electric light, a duplex paraffin lamp or incandescent gaslight is best ; the detachable mirror y (Fig. 227) goes into the drawer, and a piece of very thin flashed opal should replace the ground glass p. This flashed opal is somewhat difficult to obtain, and, if it cannot be got, an unexposed dry plate makes a capital substitute. Some workers find the yellow

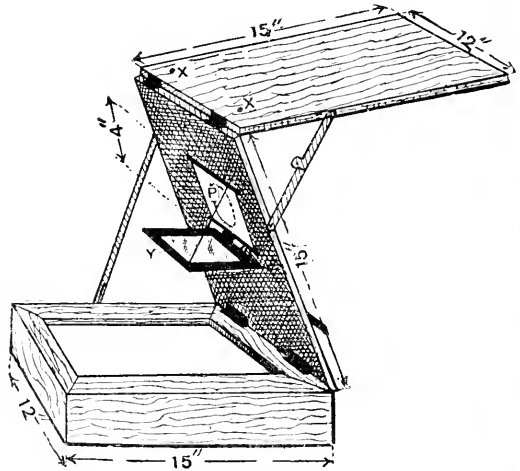

Fig. 227.—RETOUCHING DESK.

light thus obtained trying, and prefer deep blue glass to the opal ; another good substitute may be found in an old pyro. bottle filled with water, in which has been placed a little methyl blue, but either plan has the disadvantage of permitting the source of light to be seen through the negative. Some retouchers even prefer reflecting the light of an ordinary gas jet from a sheet of white card, but opal is considered by far the best.

APPLYING THE MEDIUM.

Set up the desk and obtain a good light, which in daylight is the strongest possible, not direct sunlight, and at night must be

sufficient to see the finest detail with ease and comfort; then proceed to examine the face with a view to deciding whether the negative will require a large amount of work or only a little. For example, a thin negative will require far less work than a dense one, and a face which is badly freckled more than a smooth one. The medium is applied in order to make the pencil "take" on the film. The less turps there is in it the more easily will it take the pencil. Turn the bottle upside down and back, then remove the cork, and with it just touch the ball of the finger; now rub quickly with a circular motion over the part to be worked upon. Continue rubbing and the surface begins to get tacky; but go on until it assumes a polished appearance. Very little medium should

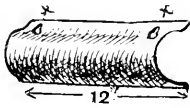

Fig. 228.—TIN PROTECTOR FOR LAMP OF RETOUCHING DESK.

be put on the negative. If too much is used it will show ridges and streaks, and be too tacky and gummy; if too little, the surface will be uneven, and not take the pencil without considerable pressure. The best plan for a negative of average density is to take plenty of medium on the finger, and rub until the surface is smooth and shiny. Do not be afraid of rubbing hard; the first attempts may be made on some useless negatives.

SHARPENING THE PENCIL.

The next thing is to sharpen the pencil. Pull out about an inch of lead, lay flat on the sandpaper block, and, holding the pencil between thumb and forefinger, as in Fig. 229, rub backwards and forwards, pressing very lightly all the time, giving the pencil a slow circular motion in the direction of the arrow. By this means a gradually tapering point should be secured, which will be found easier to work with, the fine long point enabling one to see exactly the precise spot worked on.

THE DIFFERENT OPERATIONS OF RETOUCHING.

Portrait retouching may with advantage be divided as follows:—(a) Preliminary study of the photograph, consisting of making up one's mind as far as possible as to the amount of work to be done and leading treatment of the face. (b) Broad alterations of contrast or gradation. These are usually only necessary with a bad negative, but may be required through some peculiarity of subject, and should be made at the outset. They include the brightening process of intensification and the softening ones of reduction, which may take place generally or only locally. These

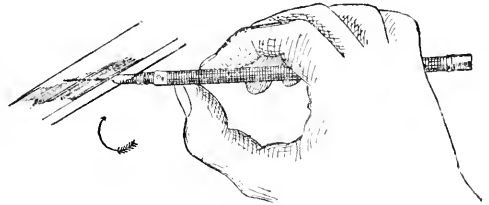

Fig. 229.—SHARPENING RETOUCHING PENCIL.

chemical operations, fully explained in another section, may be thought by some to be outside the retoucher's work, but as they form part of the work of improvement they should be included. Other methods are matt varnishing the back and scraping away certain parts, following this, if necessary, by work with chalk and stump or the point on the rough surface thus obtained; working on the back of the negative with a No. 1 pencil and medium only; covering the back of the negative with papier minéral, and cutting away the parts over the lights; dabbing crimson lake on the back with the ball of the finger till it assumes an even grain; the transparency and dusting-on methods, etc. (c) Smoothing away the freckles, pimples, discolorations of the skin, etc., by use of one of the various "touches." (d) Modelling the face, consisting of an attention to the shape of the various bones, muscles, etc., giving prominence to or toning down, as taste may suggest, and including any

necessary corrections of lighting, and all possible improvements of likeness and expression. (c) Varnishing. (f) Final correction. Each one of these six divi-

stances. Supposing that, although sharp and fairly distinct, among its faults are over-exposure, fog, and incorrect lighting. Embracing these several faults, such a



Fig. 230.—CORRECT POSITION FOR RETOUCHING.

sions will now be dealt with at greater length.

EXPERIMENT IN RETOUCHING.

Take for the first attempt at retouching an extreme case, say a photograph amounting almost to a caricature of the person and which it would be better to take again under more favourable circum-

stances. The worker should be seated comfortably and firmly as shown at Fig. 230, with the retouching desk arranged a few inches from the edge of the table to provide a resting place for the left arm and the right elbow. Its height should be such that there should be no tendency to stoop, and the hand should just reach the hole easily. The position should

be quite free from cramp and stiffness. Throw a cloth over the desk to exclude any light entering from the window or lamp; or fasten a piece of brown paper at each side.

TREATING THE NEGATIVE WITH MATT VARNISH.

Assume that the negative is too thin from under-development. Increasing the density by intensification will not remove fogginess in the shadows. It is therefore decided to slightly intensify, to follow this by matt varnishing, and cutting away the shadows and increasing the lights. This will brighten the negative. Intensification, explained elsewhere, being complete, and the negative dry, proceed to coat the back with cold matt varnish. Pour in the centre of the plate a pool of varnish about half its size and flow slowly first to the top right-hand corner, next to the top left; thirdly, to the bottom left-hand corner, almost touching the tip of the thumb which holds the plate, and pour off from the bottom right corner into the bottle again. The plate should be neither warmed nor rocked during draining; breathing on it will cause the surface to "matt" quickly. A diagram illustrating this method of varnishing is shown by Fig. 159, p. 81. Directly the plate is coated, scrape away with the blade of a large penknife the parts which cover the shadows. If the scraping is done at once the varnish should come away very easily; if not, it will be best to scrape away the edges and remove the centre part very cleanly with a rag moistened with spirit, afterwards breathing upon it and again rubbing. The varnish should be allowed to lap over about $\frac{1}{32}$ in. all round, and where the surroundings are very thin a ragged edge should be given to it. With the stump charged with a little of the lead dust left from sharpening the pencil, proceed to increase the density of the lighter parts by applying this very gently, carefully preserving their form. Here and there, where more decided lights may seem desirable, a No. 1 pencil may be used very lightly, hatching in the parts with

lines running at an acute angle as shown in Fig. 232 or as in Fig. 237. Being the thickness of the glass away from the printing surface, these lines may be a little coarse, as they blend together and form an even tint.

SMOOTHING THE FACE.

Turn over the negative, apply the medium to the film as already described, and proceed to stage *c*, that of smoothing away the freckles, pimples, etc., from the face. Each spot will have to be taken out separately, and a much finer result is obtained if a grain is produced by removing all the spots in the same way, thus forming a "touch." Although an individual may prefer some methods to others, provided the touch is suited to the retoucher, equal results may be obtained with each. Some experience should be acquired with all in order to suit the touch to any particular negative, the most valuable rule being that the touches should repeat the form of the imperfection. The touches in use resemble those shown by Figs. 231 to 238. The first (Fig. 231) "stippling," or dotting, is most suited for faces requiring but little work, and, being the simplest, is the best for the beginner to employ. The second (Fig. 232), cross-hatching, is only suitable for very large heads and big shadows. Fig. 233, "scumbling," is a good all-round touch, enabling one to work very rapidly, and is suitable for almost all heads. Figs. 234, 235, and 236 are best adapted to very freckled faces, and Figs. 237 and 238 to faces full of lines requiring softening.

MODELLING THE FEATURES.

Presuming a smooth effect has been obtained, which will require a great deal of study, the face may be modelled. Still using one of the before-mentioned touches, start with the forehead, increase the light on it above the eyebrow, rounding it into a more pleasing form. A very soft shadow occurs between this and a similar light over the left eye. The light on the cheek is next rounded into shape, care being taken not to make it too prominent or to obliterate the soft shade between it and

the lesser light below—caused by a puckering up of skin and flesh through the contraction of the zygomatic muscles—or a swollen cheek will result. Next take the light on the nose, which must begin lightly

line of the iris with a very finely-pointed pencil. The expression should be improved where possible; the general lines of the face, to give a pleasing expression, should be allowed to take a more or less upward

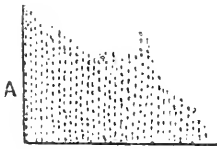

Fig. 231.—STIPPLING.

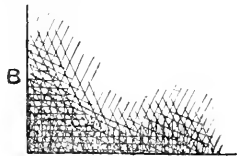

Fig. 232.—CROSS-HATCHING.

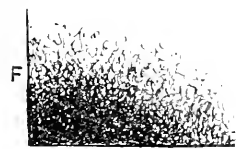

Fig. 233.—SCUMBLING.

at the frontal depression, broaden out, and soften off again, and finish with a round dot near the end of the nose. Of course, every face will vary from this ex-

direction. Especial care must be taken with the naso-labial fold (line from nose to mouth) to preserve its proper curve, for, by a most delicate alteration, it may be

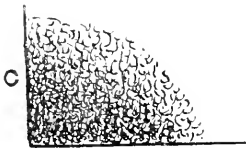

Fig. 234.



Fig. 235.



Fig. 236.

Figs. 234 TO 236 —“TOUCHES” FOR FRECKLED FACES.

ample, and the retoucher must be guided by the true form of the nose as so far rendered. In all cases modelling must of necessity differ so much that only the

made to show a smile or a sneer. It is in this stage that a knowledge of drawing and anatomy, coupled with artistic feeling, will be found of benefit.

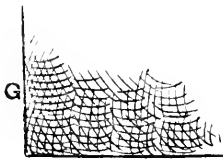

Fig. 237.

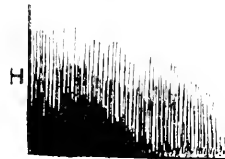

Fig. 238.

Figs. 237 AND 238.—“TOUCHES” FOR SOFTENING LINES.

broadest rules can be given. The light on the upper lip seldom needs more than shaping, but the two lights on the lower lip may often be brightened with advantage. The chin should be well rounded, and care should be taken to preserve the dent or dimple. As little as possible should be done to the eyes, but sometimes they may be brightened with light specks in the iris, accompanied by a reflected light below and a sharpening of the out-

SPOTTING.

As the film takes the paint more readily than does the varnish, the negative should be spotted before varnishing. Spotting consists in removing the tiny pinholes caused by dust or defective plates. The smallest of these may be touched out like ordinary spots with a No. 1 or No. 2 pencil, but the others will require stippling out with a No. 2 brush and Indian ink. It is considered by some workers a convenience

to have the paint on a piece of glass, so that it may be held up to the light and its density correctly matched. Taking up what is considered sufficient, just touch the spot very lightly with the extreme tip of the brush. The great point in spotting is to keep the paint as dry as possible. If the paint is too wet, a ring will be made round it and the spot itself will remain untouched. Some spots, however, in spite of care, resist the obliterating treatment, and the only thing left then is to paint over somewhat opaquely, and obliterate them in the final spotting in the print. This spotting of prints is much neglected by the amateur. Prints—particularly those in platinotype—issuing from the leading studios are worked upon by skilled artists to a considerable extent. The easiest plan is to stipple in the part with water colour. Mix crimson lake, ultramarine, and black to match the photograph. For platinotype of bromides, ivory black and a little ultramarine should be used. Soak some lumps of gum arabic in water and melt by warming. Mix well a few drops with the paint; the surface should then have on drying the same appearance as the surrounding parts. It is well to have a cup of thin gum water at hand to dip the brush in occasionally. Keep the touches even and close together.

VARNISHING AND FINAL CORRECTION.

Varnishing is necessary as a protection against scratching, but even more against damp, although if negatives are stored in a damp place for a considerable time silver stain is bound to result, however good the coat of varnish. Should this occur, the varnish must be removed and the negative treated with a dilute solution of sulphocyanide of ammonium and nitric acid. The operation of varnishing is conducted as described for matt varnishing, except that the negative must first be gently heated until just warm to the back of the hand. Should the heat be even a little too much, some of the retouching, which may have taken a considerable time to do, is very likely to come away. It is best to have the varnish fairly thick and to warm the negative but

slightly, this assisting the proper drying and preventing "frosting." Afterwards bake the negative hard by a slow heat for two minutes, and then put it aside for a time, when one can return to it with new ideas, just as an artist sometimes turns his picture to the wall for a time in order that, when again taking it up, he may better see its defects. The final correction, of course, means the careful examination for any omissions in the previous work. Turn the negative all round to discover any tiny spots still left, and look it carefully over from both front and back, viewing it also from various distances.

REASONS FOR VARNISHING.

The reasons for varnishing the negative are as follows: (*a*) as a protection against damp; (*b*) as a protection from abrasions of the film, or to prevent the retouching being disturbed; (*c*) as a support for further retouching. (*a*) If the negative is printed from without varnishing, there is always the danger of staining. Free silver nitrate or citrate contained in the paper is liable to enter into combination with the gelatine, if in the presence of moisture; which moisture may be due either to the state of the atmosphere or to the presence of citrate of soda in the paper. Either of these may lead to the production of orange-red stains, which are exceedingly difficult to remove. Perhaps the best plan is to treat them with a solution of thiocarbamide or a mixture of nitric acid and ammonium sulphocyanide. Prevention is better than cure, however, hence the necessity of varnishing. (*b*) The constant friction arising through placing paper upon the film of the negative must in time remove some portion of the working up, which may have a disastrous effect on the picture. It is easy to conceive that this might be worse than removing the whole of the retouching, and it will certainly be the finer and lighter work which will be the first to suffer. (*c*) When retouching a negative which requires a large amount of work, it will generally be found that the deepest shadows require considerably more lead than can be persuaded to stay on the medium, unless a

very soft pencil is used, which is not always convenient. The only way out of the difficulty is to give a coating of varnish, which will form a basis for a further application of medium, upon which more retouching can be done.

DANGERS OF VARNISHING.

There are some disadvantages arising from varnishing, and these occur chiefly through the work being done improperly. For example, if the plate is made too hot, the effect will be to melt the medium and cause it to run in with the varnish as it is poured over. This will mean that the lead will also be disturbed, and the good qualities of retouching, such as precision of touch, will be completely lost. If the varnish is extremely thick, there may also be some loss of definition; but this is so slight that for all ordinary work it need not be taken into account. Other dangers are those of dust; frosting on the surface through having the plate too cold; streaks at the side of the negative through not draining properly; and marks across the negative caused by ridges of varnish. In this latter connection, it should be mentioned that the dangers arise through the varnish not being of proper consistency. If it is too thin, it is liable to dry with a frosted surface; and if, on the other hand, it is too thick, it is exceedingly liable to cause ridges. On no account should the varnish be allowed to run back over the plate after coating; that is to say, the corner from which it is drained should always be the lowest.

METHODS OF VARNISHING.

The act of varnishing the plate is exceedingly simple, and has been already described. An appliance may be made useful for dealing with a large quantity of negatives. It consists merely of an iron tray supported upon four blocks, beneath which is placed a small stove. Three plates may be dealt with at the same time with such an apparatus: one negative is warming, and two baking, while in the rack are two negatives draining, and as each of these becomes ready to bake it is placed on the tray in place of one of the others.

VARNISHES.

The simplest photographic varnish consists merely of the ordinary white, hard varnish, obtainable at any oil shop, diluted to proper consistency with methylated spirit. It is hardly worth the trouble to make one's own, unless working upon a very large scale.

VIGNETTING.

The method used for shading away the outer portions of a picture is termed vignetting, and was at one time practised very largely by all photographers; so much so that pictures which included head and shoulders only were generally called vignettes. The practice, however, has fallen into considerable disrepute amongst the better class of photographers, few of whom now treat their pictures in this way if it can be avoided. It is quite true that vignetting may be made use of to produce a very pleasing result, where the subject is light, full of half tones, and the background light but in pleasing contrast. Vignetting was welcomed by the old school of photographers as a means of covering up the marginal defects of their portraits. Stains and marks were a little too frequent on negatives, evidences of deterioration in the plate showed first at its edges, whilst the lenses used were capable of covering the margins none too well, and for all these reasons photographers joyfully hailed any excuse for using only the inner portion of the image. While they kept to head-and-shoulder pictures, their clients had perhaps little to complain of; but when they commenced to vignette three-quarter lengths, landscapes, views of houses, and even machinery, the public mind rose up against it. Vignetting, then, should be kept to suitable subjects. If vignetting is indulged in, the effort should be to obtain an effect similar to a sketch: the idea being that in such pictures the figure is thus thrown forward prominently. To obtain the best effects, a light background must be employed: although, by a skilful arrangement of the vignetter, it is possible to do much to soften a fairly dark one. A really dark back-

ground, however, cannot be successfully vignettted by any method but the "India tint process." The background, on the other hand, must never be quite white,

only. The glasses used are flashed either orange or red. The centre portion of the colouring matter is removed by treatment with hydrofluoric acid: aiming to leave the margin as soft as possible in the process. The margins are, however, very



Fig. 239.—VIGNETTING GLASS.

and usually a tone deeper than the head. The choice of a suitable background for photographs is considered in another section, the principal point to bear in mind being that it should graduate darker towards the bottom.

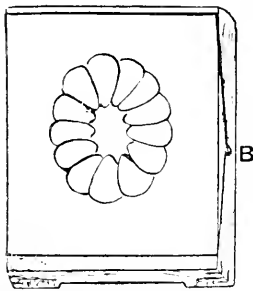

Fig. 240.—"IRIS" VIGNETTING FRAME.

METHODS OF VIGNETTING.

For the purpose of vignetting there are practically four devices in use: the first, Fig. 239, consists of a piece of flashed glass with a colourless centre. Flashed glass is prepared by taking up a ball of molten colourless glass on the end of the blowpipe, then dipping it in a molten coloured glass for a few seconds and blowing the two together, so that the colouring matter exists on the surface



Fig. 241.—FLAP FOR "IRIS" VIGNETTING FRAME.

hard at the best, and the results obtained with such glasses are generally crude and inartistic. Vignetting glasses are never used by any but inexperienced amateurs. Fig. 240 shows the "Iris" vignetter, which consists of a piece of vulcanised fibre large enough to cover the frame, and containing a central hole rather larger than the largest desired vignette opening. Around the edges of this are

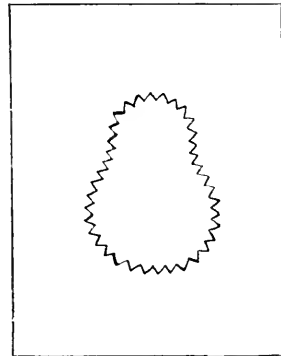

Fig. 242.—SERRATED VIGNETTER.

riveted flaps, cut as shown in Fig. 241, and fitted together as in Fig. 240, each one slightly overlapping the next. The flaps are folded back or brought forward according to the desired shape of the vignette. This certainly has the advantage that it may be repeatedly adjusted, and of all ready-made vignettters is the most satisfactory. Zinc vignettters, which consist of a sheet of metal with a centre opening, are often useful. When their edges are serrated, as shown in

Fig. 242, they may be turned outwards: this tends to soften the shadows thrown. These vignettes have the advantage of durability, as have also the wooden vignettes shown in Fig. 243. These are made in wood about half an inch thick and bevelled inwards. Another method of vignetting at one time practised by amateurs is by means of cotton wool. A sheet of wool of sufficient size is cut off and an opening made in the centre. The wool is pulled out loosely around the edges. Black wool is preferable, as it stops a little more light. Generally speaking, the method is unsatisfactory, as the vignette is so liable to disturbance and

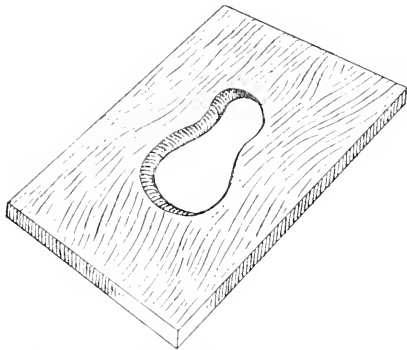

Fig. 243.—WOODEN VIGNETTER—UNDER SIDE.

is not sufficiently opaque. In commercial work also it is essential that the vignetter should be of a permanent nature to ensure each print being alike. A great deal of discussion has taken place as to the shape and method of cutting the vignettes: some workers punch a hole with a gouge to the shape shown in Fig. 244. Others contend that such edges have practically no effect on the result, provided the vignetter is put at sufficient distance from the negative. The form the vignette should take is governed by the tones of the picture, so that it may not spread unequally in any direction. Generally speaking, it should not repeat the outlines of the figure, nor should it be tied down to any arbitrary shape. For this reason, therefore, vignettes should seldom be

purchased, but made as required. This is the practice adopted at all large printing establishments. The printer takes a sheet of card about the size of the outside dimensions of his frame, and on this he sketches roughly in pencil the shape the vignette is to take, or rather the shape it will be necessary to give to the vignetter to produce that effect. The opening must



Fig. 244.—METHOD OF PUNCHING VIGNETTER.

be made somewhat smaller than the desired effect on the print, to allow for spreading. Now, the amount of spreading, and therefore the degree of softness, will depend upon the distance the vignetter is from the negative, and the kind of illumination which the negative is to receive. This is the point where the majority of inexperienced workers stumble, the vignetter being mistakenly fixed too

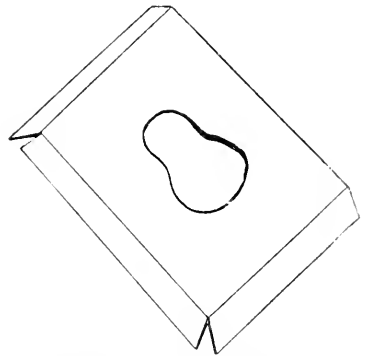

Fig. 245.—PLATE-BOX VIGNETTER.

close to the negative. A moment's consideration will show that the farther the vignetter is from the negative, the greater the spreading of the light, and that the farther the light spreads the more delicately must it shade off from one tone to another. Moreover, where the source of light is small, such as that used when printing bromides, a sharper shadow will be cast. Where the source of light is large,

that is, where diffused light is used, such as ordinary daylight, the vignette will be more inclined to spread unequally. It will have been seen that the thinner the negative the more the light will stray: such portions require more shading—that is to say, the vignette must come a little closer, and in extreme cases it is even necessary to lay a little cotton wool over the part. The cotton wool must have the softest possible edge, which may be obtained by pulling it out loosely. One kind of vignetter consists merely of one half of a plate box, the corners of which are broken open so that when tacked to the frame it stands out from it as shown in Fig. 245.

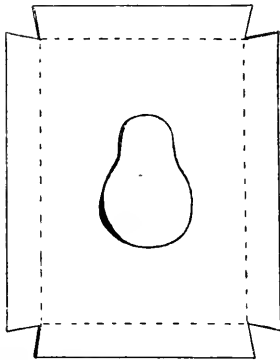

Fig. 246.—CARDBOARD VIGNETTER, SHOWING METHOD OF BINDING.

Another form of which this is a modification is shown in Fig. 246, also made to stand out. It is cut from one piece of card, scoring on the dotted lines shown so as to bend into the shape indicated. An excellent arrangement for vignetting, having a muslin frame for diffusing the light, and allowing the vignetter to be adjusted in any desired position, is shown by Fig. 247. It is known as Salmon's Vignetter, and is obtainable at any photographic dealer's.

ADJUSTING THE VIGNETTER.

The printer, having placed the negative in the frame, holds it up to the light to adjust the vignetter in front of it, so that the negative is between it and his eye. Should the lights appear not to spread

sufficiently, and it is always as well to cut them too small to begin with, he breaks or cuts away portions until the desired result is obtained. The effect is judged better by looking at, say, a ground glass window, and at any rate it cannot be well estimated by looking at a bare gas flame: half closing the eyes gives, also, a more correct idea of the spread of the vignette. If the printer detects any thin shadows which appear likely to spread unequally, he tucks in a little

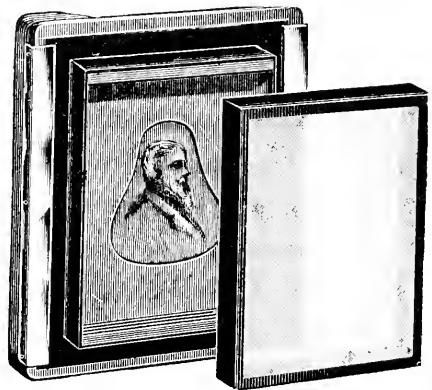

Fig. 247.—SALMON'S VIGNETTER.

cotton wool over these parts as suggested: having first of all, however, fixed the vignetter to the front of the frame with pins to prevent moving. When vignetting by print-out methods, which should be those first employed, the picture must be looked at occasionally, and if the image is found to be spreading too much, or too little, or unequally, the vignetter may be altered accordingly. When the vignette has spread too little, it is easy to break it open: but when it has spread too much, the best plan is to stick a sheet of tissue paper over the opening and to paint the surplus portion with Bate's black, taking the frame into the printing room, and holding it up to the light for the purpose. Of course, such an alteration, to be of any use, needs to be made in the early stages of printing. When printing by development processes the vignetter should invariably be covered by a sheet

of tissue paper, except perhaps in the platinotype process, as the quicker the printing the greater will be the tendency to hardness in the result. Tissue paper has been found to increase the exposure three times, and, although the transparency of tissue paper of different qualities must vary, there seems to be surprisingly little difference in these. The portion of the frame in relation to the

to keep vignette frames on the move throughout exposure, by turning them round occasionally; this increases the softness of the result. At some establishments, the frames are laid on a board, suspended from an arm by means of a bottle jack, as shown in Fig. 248. The prints are thus kept continually on the move. Some twisted wool or string could be made to take the place of the bottle jack, it being then necessary to give the board an occasional swing. Such arrangements admit of printing in a brighter light. These are the methods of obtaining an ordinary vignettted picture.

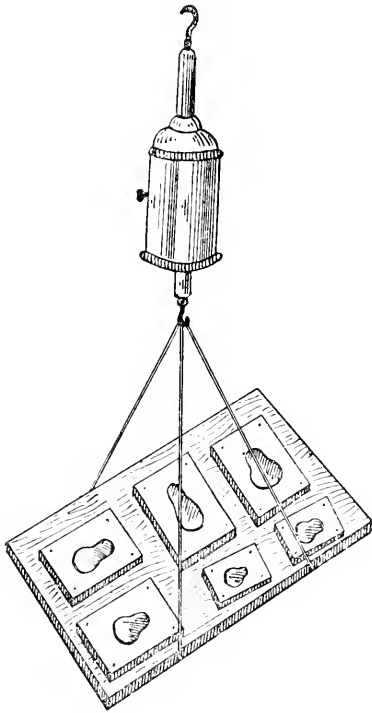

Fig. 248.—USE OF BOTTLE JACK FOR VIGNETTING.

light greatly influences the shape of the vignette unless tissue paper is used, even with diffused daylight. It is, however, a fallacy to suppose that if tissue paper is placed over the negative printing may take place in the sun, for it will be found that a shadow of the opening will still be cast on the negative. If, however, another piece of tissue paper or a muslin frame is placed above at a short distance this becomes the source of light and the shadow vanishes. It is advisable

INDIA-TINT VIGNETTES.

The production of these is an old process which has recently come much into favour, and consists of first vignetting the picture as has just been described, then covering the portion printed and allowing the paper to print down to any required depth by exposure to the bare light. In printing-out processes, it is not advisable to use too bright a light for tinting down. The centre portion may be shaded by means of a glass to which has been attached several pieces of tissue paper, each one about $\frac{1}{2}$ in. smaller each way than the next; giving an appearance when looked through of that seen in Fig. 249. This is laid over the print, which is placed face up on the glass and moved slightly during exposure. Some printers, however, merely cover up the centre portion with a duster or a tuft of wool. The effect of such vignettes is most artistic, as the attention is centred thereby upon the head, and any unpleasing details near the margin may be subdued. Take, for instance, the bust of a lady when the head is to be small. The waist must show if printed plain, but by this means it is possible to give only a faint indication to it. An example of such a vignette is given in one of the full-page plates. In some cases, the first vignette may be dispensed with.

VIGNETTING THROUGH THE CAMERA.

This was a method at one time much practised, and gives a very striking result.

The advantage, however, lies in obtaining softness while preventing too much spreading. In the case of persons wearing white dresses the effect is weird, not to say hard; but when the model is dressed in a costume of pleasing half tints, wearing, say, a lace collar round the neck, the effect may be made very pleasing. It will be understood that the method is only suitable for children and ladies. Cut the card to the exact interior dimensions of the camera bellows, and in the centre of this cut an opening to the shape of the desired vignette. Place this card inside the camera (it may usually be supported by the folds of the bellows) so that it comes about one inch away from the dry plate. The exact distance will depend upon the character and quantity of the light, and is best found by experiment; the effect being usually judged by the appearance on the focussing screen. If the outline appears too defined, it must be removed further away; while if it appears to spread too much it must come closer. In judging the effect on the focussing screen, the eye must not be placed too near, but the general effect taken. An example of one of these vignettes is given in one of the full-page plates. Another method which has been tried consists of placing in the dark slide a glass prepared after the manner of the vignetting glasses. This comes in front of the dry plate, and, of course, shields out the margins of the picture so that they appear as clear glass on the negative. Such an arrangement is managed in the studio slide, but due allowance must be made for the alteration in the focus by readjustment of the register to the focussing screen. The method cannot, however, be recommended, as the results are bound to be more or less hard as compared with the former plan. There are various other methods of obtaining curious marginal effects, but of these one or two only need be described.

THE MOUNT EFFECT.

Set up an ordinary cut-out mount having the plain tint of some art paper, or a very striking result is obtained where

the mount is shaded from one side to the other from dark to light. See that the dark side comes against the lightest side of the picture. A piece of black paper is placed over the opening in the mount, and the copy negative is then made on a slow plate to the required size. From this negative a positive is taken which, when dry, is placed in a dark slide as in the last process, the film being in contact with that of the plate (it is an advantage instead of using the black paper to cut away the film of the negative, but it requires considerable skill to get a good, clean edge). An exposure is now made in the usual manner, but the negative will have the appearance of the person having been taken behind the mount. An example of this is given in one of the full-page plates.

CLOUD VIGNETTES.

Another method capable of giving very pretty effects is the cloud picture. A plate is vignettted in the camera and is afterwards exposed, before developing, in a printing frame beneath a cloud negative, the centre portion of which is shielded as shown in Fig. 249. Another method of making these pictures is explained under the heading "Combination Printing."

MASKING.

It sometimes happens that pictures, owing to marginal defects, cannot be printed plain, yet do not lend themselves to vignetting; and in these cases it is usual to employ masks of various shapes, cushions, ovals, circles and domes, as in Fig. 250, Fig. 251, Fig. 252, Fig. 253, being the usual form. As these are merely laid on the face of the negative, and the printing paper placed above them, further description seems unnecessary. It is generally more artistic to have a dark margin instead of a white one, so that after printing the centre may be covered and the outside tinted down, as described in the making of India-tint vignettes. When a box of masks is purchased it will be noticed that the centres are usually included for that purpose.

BORDER VIGNETTES

Another kind of double printed vignette is done by printing over the masked portions with a negative, similar to that made with the "mount" picture.

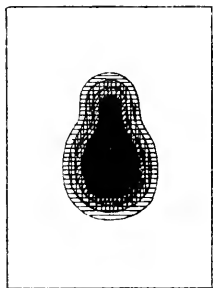

Fig. 249.—GLASS FOR INDIA-TINT VIGNETTES.

Such border negatives may take the form of a group of flowers arranged around a shield, or one of the ornamental tablets sold for painting upon. If these are used, the tablet need not be blocked out when painted in a dark colour, as they generally shade off in a very soft and pleasing manner. The reader will no doubt be

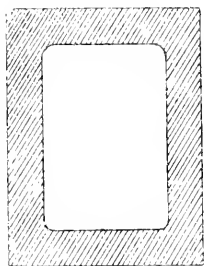

Fig. 250.—CUSHION MASK.

able to think of many other modifications of this method of printing, such as marble borders, picture frame borders, etc., all of which would be treated in the same way.

MEDALLION VIGNETTES.

These resemble the India tint vignettes, except that in printing down the centre mask is kept still, and prints with a sharp edge. Another striking effect is obtained

by the subject writing his signature on a small piece of translucent paper, which is attached to the glass when printing down.

COMBINATION PICTURES.

These form perhaps the most difficult, and yet the most generally useful, of any

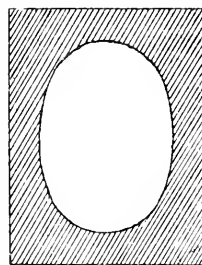

Fig. 251.—OVAL MASK.

of the tricks of printing. The simplest but least successful method consists of merely cutting out the different portions, and, after sticking them in position either on another photograph or on a plain card, the surrounding or connecting parts are carefully painted and stippled in. From this a copy negative is made, and printed

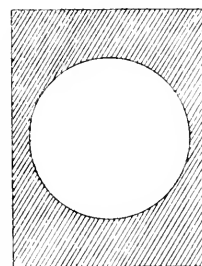

Fig. 252.—CIRCULAR MASK.

from as usual. This method is only of use in the hands of one having a good knowledge of drawing and retouching, owing to the large amount of handwork entailed. The necessity for copying, and its accompanying loss of detail and gradation, are also serious drawbacks for ordinary work; although for process reproduction this makes no difference comparatively. In the best combination printing, little or no handwork is employed. In some

of the examples of the late Mr. H. P. Robinson a large number of negatives were used to produce the effect. It will be seen, therefore, that unless each printing is carried out most carefully, an error in one part of the work may ruin the whole. The work is specially applicable to "subject pictures," or to the definite construction of pictures intended to illustrate a poetic or dramatic situation.

REGISTRATION.

The chief difficulty likely to be met with in combination printing is that of correct registration, or getting the various

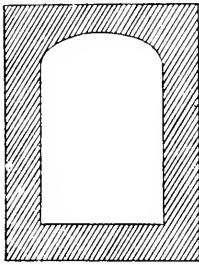

Fig. 253.—DÓMED MASK.

parts to join up together naturally. To effect this, see that the joining does not come in a very prominent place, if it can be avoided. If, however, there are any well defined outlines these may be chosen for the joining boundaries, as the two sets of lines can be more easily blended. For example, it was discovered that it was easier, and resulted in a better join, to make the boundary the outer edge of the frame rather than the inside, which had a more broken edge: as in this case it was necessary to mask the small negative so that it also had an uneven edge exactly agreeing. Suppose, for example, that a new head has to be printed on a figure, as often happens where a figure has moved in an important group, which cannot be taken again: the joining up can generally be done best by taking the line around the collar as the boundary. Whilst speaking of this, it might be mentioned that a plan, sometimes adopted by photographers who make a speciality of flattering their

subjects to any extent required, is to photograph the head merely, and to take a separate negative of a model having an excellent figure in a similar dress. The two negatives are then printed from in combination.

INTRODUCING BACKGROUNDS INTO PORTRAITS.

A use to which combination printing might be put more frequently than it is at present, is that of introducing natural landscape backgrounds or characteristic scenes into portrait pictures. To do this, proceed as follows: Paint out the whole of the background in the portrait negative with Bate's black varnish; this must be done with extreme care around the figure, and it is well to commence with about $\frac{1}{8}$ in. margin all round the outline of the latter, using a No. 2 brush for the purpose. In going round the hair, the line may be purposely broken, but in the face the outline must be travelled with extreme care and accuracy. If there is a deviation from the precise line, it should be to show too much rather than too little; in fact, if about $\frac{1}{100}$ in. more is shown the effect will be softer; the remaining portion can then be blocked in. It frequently happens that the outline of the figure itself is fairly diffused, and if such is the case the varnish may be put upon the glass side of the negative, which will give a much softer effect. If this cannot be done, the outline may be purposely broken by serrating the edge with the point of a scalpel. Where, however, it is known beforehand that a new background is to be introduced, the portrait should be taken against a pure white background. By this means the blocking out is avoided. This method will give a very pleasing effect to the added landscape. A print should now be taken, and the figure very carefully cut out and laid face downwards on the landscape negative, in the position it is to occupy in the finished print. A little gum carefully applied to its edges will serve to fix it in place. Suppose, now, a print is taken from the figure negative; it is removed from the frame and placed over the landscape

negative, so that the printed figure covers the masked portion. It frequently happens that the first print taken shows a line of demarcation, and the mask or the blocking must be carefully pared away until both combine accurately and softly. It will be found that three-quarter length pictures are the most successful, as the junction with the foreground is apt to be unnatural in full length pictures. This is easily overcome if a continuous background is available, of similar tone and nondescript design.

COMBINATION NEGATIVES.

However carefully combination printing may be done, there is always the danger of the prints being unequal, and that the exact contrast of tone may not be the same in several prints taken from the same negative. The best plan, theoretically, is to combine the pictures on the negative, but this is not always possible, and is invariably very difficult. An example of this kind is shown in one of the plates. In this case the negative is printed from in the ordinary way. The method of making such a negative is as follows. The portions representing the figure and background are upon a 12 by 10 plate, and were taken in the usual manner. A real lattice window was employed, and outside this was placed a dark background of even tint. On a 5 by 4 plate (or just a little larger than the opening in the window) was taken a sunrise view, purposely a little out of focus. This was attached to the glass side of the negative with a little gum at each corner. Portions which appeared too dark were modelled up with the brush, and those which were too dense were locally reduced with a little ferricyanide and hypo. It ought to have been mentioned that the view was "vignetted" in the camera: that is to say, it was taken through an aperture in a card of about the size of the opening in the window, so that it had no sharp or decided margins. Two negatives were then taken of heads of different size, and vignetted in the camera as before, and the film stripped, cut out, and floated upon a cloud negative.

A portion of the cloud negative which might otherwise have covered the figure was then cut away, and the whole attached to the glass side of the 12 by 10 negative, as in the case of the sunrise view. The negative thus made up is ready for printing without further trouble. Such work opens up the way for a practically unlimited play of artistic feeling, and deserves, in spite of its many difficulties, to be far more practised. True, it is not perhaps a perfect method of artistic expression, but what method is? Some photographers—possibly those who have tried and failed—affect to despise such work, yet they have admired pictures so produced without being aware of the method of production; whilst, on the other hand, like the taxidermic critic of the live owl, who found fault with the stuffing, they will sometimes call attention to the unnatural combination of two things which actually are upon the same negative. The late Mr. H. P. Robinson, the finest exponent of this class of work photography has known, used to tell some amusing incidents of this kind. It goes without saying, that unless the work is done with extreme care and proper attention to detail, the results may be exceedingly bad. Combinations which are purposely incongruous are dealt with in a later section.

INTRODUCTION OF SKIES.

The veriest novice must have discovered that the majority of photographs, even when properly exposed and successful in other respects, are exceedingly disappointing in the sky, which usually photographs as a blank patch. Sky shades, etc., of different designs have been introduced, all of which have proved quite insufficient for true sky rendering. The simplest treatment of the sky consists of sunning down, or printing down, with which the reader has been made familiar in the remarks upon masking and shading. Something more than this, however, is required; and the best effect can only be obtained by printing in a sky from a separate negative. There are, of course, occasions when the clouds in the sky may be secured upon the same plate, but these are the exceptions:



SPECIMEN OF UNDER-EXPOSED NEGATIVE.

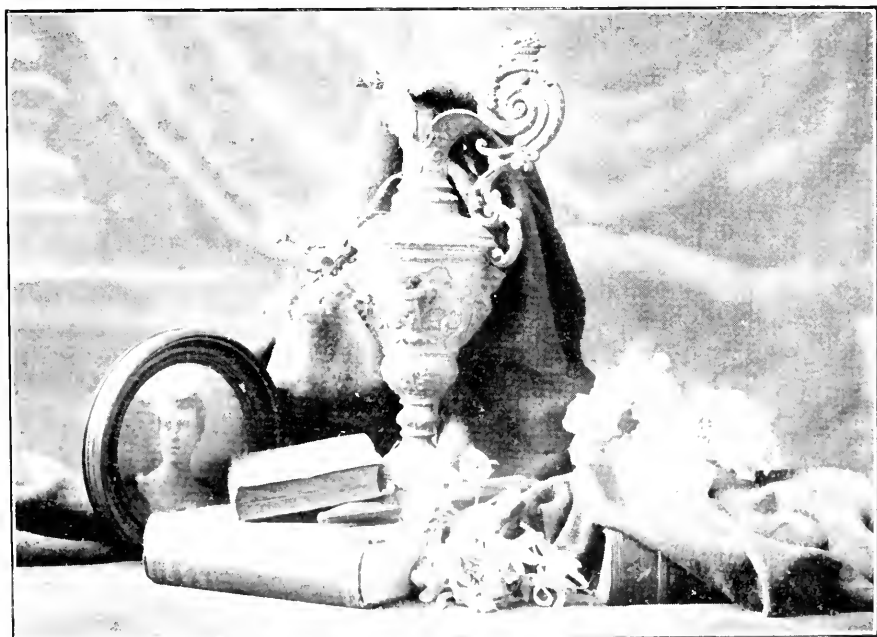

SPECIMEN OF OVER-EXPOSED NEGATIVE

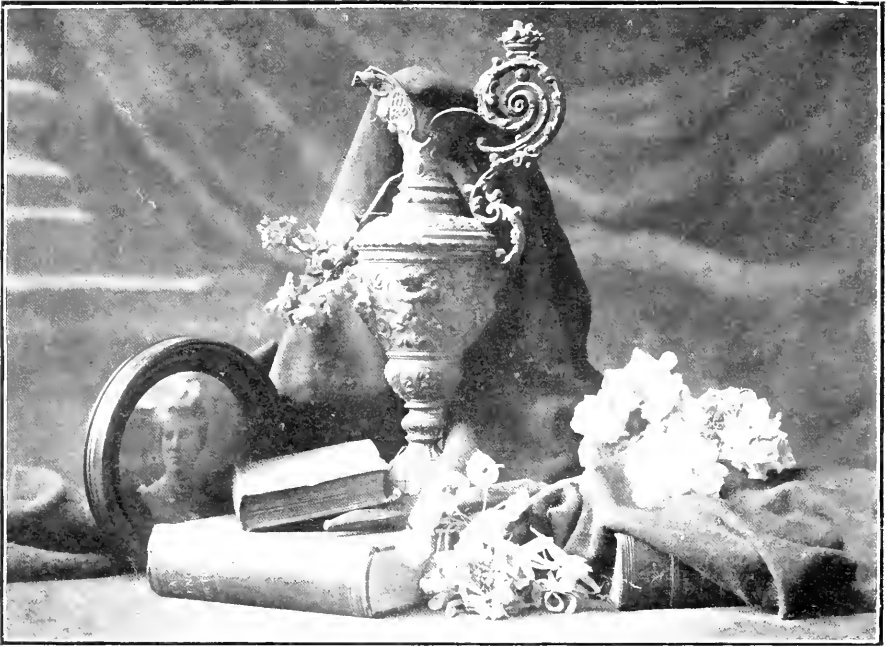

PRINT FROM CORRECTLY EXPOSED NEGATIVE.

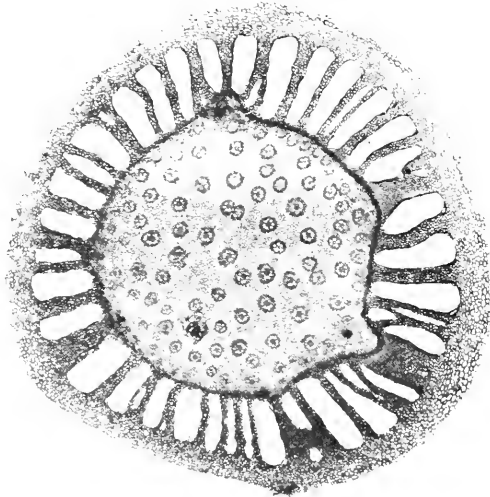

EXAMPLE OF PHOTOMICROGRAPHY.

PHOTOMICROGRAPH OF *JUNCUS LAMPROCARPUS*; MAGNIFIED 20 TIMES

and although, theoretically, they should give the best result, it does not necessarily follow that they will do so practically.

CHOICE OF CLOUD NEGATIVES.

The first consideration should be the lighting of the negative. It is essential that both sky and landscape should be lit from the same direction, or the fake will be apparent. Secondly, the contrast must be in keeping with the contrast in the foreground, although this depends to some extent on the depth of printing. Clouds taken near sunset, combined with a landscape taken near the middle of the day, will, of course, have a most artificial effect. Thirdly, the lines made by the clouds must harmonise with and serve to balance the lines of the landscape.

TREATMENT OF THE LANDSCAPE NEGATIVE.

It is essential that the print of the landscape negative should come off with a good clean space representing the sky, and to ensure this it may either be blocked out with black varnish or shaded in printing. The latter plan is preferable, as it is difficult to avoid a hard line with the varnish. Still, if it must be used, then the edges of the varnish are dabbed with the ball of the finger, so that the two tones graduate into each other as well as possible. A piece of card fastened across the frame, either with a serrated edge or one which curls upwards, may be used; but perhaps the best plan is to soften the edge of the card by means of a strip of loosely arranged cotton wool. If the negative has a level horizon, this is a simple matter; but if it possesses a tall spire, ships' masts, etc., then these must be roughly vignettted around. It frequently happens, however, that the sky in a good negative is dense enough, and does not require any masking. In any case, care must be taken to remove spots or pinholes, as these would be especially apparent on a light ground. The print is now removed from the frame, and placed in a much larger

one, containing the cloud negative, to allow of proper adjustment. As these negatives are usually upon films, they can be printed from either side; and, if lighted more from one side than the other, can be made to match with the negative. The print is then adjusted over the film, and the frame closed up. Before exposing to the light, it must be masked so as to cover up the portions already printed on. In the case of a spire or masts, as already referred to, they may be ignored, and the clouds printed right over them. If printed to the proper depth, the slight difference in tint on them will not be distinguishable.



Fig. 254 — ANGEL PICTURE.

The two great mistakes made by novices in this work are printing too deeply and joining up abruptly. The lighter the sky is printed, the more natural will be the effect, and the easier to produce; while the worker's aim should be to vignette the landscape portion into the sky portion, and not to make both join accurately. Very good skies may often be introduced on the negative itself by means of local treatment with ammonium persulphate, as described in the section on Reduction. Great care is, however, required to produce artistic results.

ANGEL PICTURES.

A very pleasing way of making angel pictures is as follows:— Procure two ducks' wings. These should be pulled out to their

fullest extent, fastened down on a board, and dried in the oven; they will then retain their shape. They may be fastened on to the back of the garment, or to the chair, by means of large safety pins. A head and shoulder picture is then taken in the usual manner, and a vignetted print obtained. The margins are now printed upon under the cloud negative, the centre portion being masked. An example of these is shown in Fig. 254. The above remarks have been made with special reference to print-out methods. In the case of development methods, such as carbon, platinotype or bromide, the difficulties increase greatly, and for such processes the combined negatives possess an additional advantage. Broadly speaking, the differences between the two methods to be employed are: (*a*) Printing must go on under tissue paper; (*b*) the picture must be marked out roughly on the back of the print to indicate the

portion printed; and (*c*) the proportionate exposure between the different parts first found by experiment. If these points are each carefully attended to success should result.

CONCLUDING REMARKS.

It will have been seen that by means of retouching, and other special treatment of the negative, the character of the latter may be so altered as to give an entirely different picture to what would have resulted in the ordinary way. Combination printing, also, gives added powers of modification to the ambitious photographer. The subject has been treated here more from a practical and interesting point of view than with much regard to the canons of what is known as "pictorial" photography. Pictorial work will, however, have due consideration in the future sections, particularly in that dealing with Landscape Work.

PRINTING-OUT PROCESSES AND PAPERS.

INTRODUCTION.

THE earliest attempts at photography consisted of experiments in obtaining print-out impressions—that is to say, impressions which were directly visible independent of the action of a developer. In photographing upon paper, the first process worked in this country, introduced by Wedgwood and Davy, consisted merely of exposing paper coated with silver nitrate to the action of light. Even before this time—in fact, in 1777, when Scheele discovered that silver chloride darkened on exposure to light—print-out impressions of a kind had been made. The subject, however, having to be dealt with from a practical point of view, and these earlier processes possessing merely historical interest, there is no need to enlarge upon them.

SILVER CHLORIDE.

When metallic silver is covered with sufficient nitric acid, the silver will be dissolved, and on evaporating this solution, flaky transparent crystals will result. This is silver nitrate, to which chemists give the formula AgNO_3 , it being a compound of silver (argentum), nitrogen, and oxygen in the proportions indicated—that is, 1 atom of silver, 1 atom of nitrogen, and 3 of oxygen. If the silver nitrate is dissolved in distilled water, which should always be used for gold, silver or oxalates, a perfectly clear solution will result. Place a small quantity of this in a test tube, and in another

test tube dissolve a pinch of common table salt, known chemically as chloride of sodium, and having the formula NaCl . Pure distilled water should again be used, so that one tube contains sodium, chlorine, and water, and the other the three elementary substances mentioned above. Now if a portion of the salt solution is added to the silver nitrate (AgNO_3), there will immediately be a heavy precipitate of silver chloride (AgCl) which is of a cream colour. The silver chloride is insoluble in water, and therefore sinks to the bottom. What has taken place? $\text{AgNO}_3 + \text{NaCl} = \text{AgCl} + \text{NaNO}_3$, or silver nitrate added to sodium chloride forms silver chloride and sodium nitrate, this being the manner in which the change (known as “double decomposition,” or “mutual chemical exchange”) is expressed by chemists. The silver having a greater affinity for the chlorine than it has for the other substances, readily combines with it. If this silver chloride is exposed to sunlight, and allowed to remain for a time, it will slowly darken to a violet colour, whilst parts shielded from the light will remain white. Such was the crude form of printing in the earliest photographic processes; its limitations will be at once apparent.

“PLAIN SALTED” PRINTING PROCESS.

The preparation of photographic printing paper is work which can be carried out so much more successfully and economically on the large scale adopted in

factories that it would be unwise for any photographer to attempt it for other than experimental purposes. Considerable practice and experience are necessary to ensure perfect results, and thus the user of the paper would not in all probability have the time to acquire. However, for the proper understanding of the various printing-out processes a little experimental work will prove exceedingly valuable. The earliest and simplest printing process, known as "plain salted," may be briefly described. Papers soaked in a solution of a chloride are floated on a bath of silver nitrate, and afterwards exposed beneath a negative until somewhat darker than the finished print is desired; then, they are fixed in a solution of hypo. From this it will be seen that the sensitive substance consists largely of silver chloride, and the operations comprise (a) salting, (b) sensitising, (c) toning, and (d) fixing.

CHOICE OF PAPER.

Any ordinary pure paper may be employed, but if used in its natural condition the results will be exceedingly flat and unsatisfactory. An experiment will serve to make this clear. Enclose between two pieces of glass a small quantity of chloride, and on another piece of glass expose some silver nitrate and gelatine over which has been poured a solution of common salt; take also an unsized Swedish filter paper and a piece of ordinary writing paper, immerse both in a solution of silver nitrate, and when dry immerse in a solution of common salt. There will then be silver chloride alone on glass, silver chloride with organic matter on glass, silver practically alone on paper, and silver chloride with organic matter on paper. Now when the silver chloride is alone, it will be found on exposure to light to darken to a blue violet; with organic matter it will darken to a brown. Further, on treating both with a solution of hypo., it will be noticed that where the silver chloride is alone it will be dissolved almost completely away, but where it is with the organic matter very little will be dissolved. This at once shows the presence of something

more than silver chloride, or that a different substance has formed, of another colour, less acted upon by the fixing solution. This organic salt of silver plays an important part in the process, as it determines both the colour and the intensity of the image. In practical working, the sensitive compound consists not only of silver chloride but of an organic salt of silver as well.

SIZING OF PAPER.

In examining the image obtained on the writing paper, it will be noted that it is flat and sunken in appearance, and, with a view to explaining this, let a further experiment be made. Take a sheet of writing paper, cut it into halves, and immerse one half in a weak solution of arrowroot starch, or gelatine; then pass both pieces through solutions of silver nitrate and sodium chloride, and print beneath the negative. It will be found that the image upon the writing paper which has been through the starch solution is brighter and clearer, the image existing on the surface of the paper. This shows that the filling up of the pores of the paper with an organic solution fulfils a twofold purpose. First, it causes the formation of a new silver compound; secondly, it serves to keep the image on the surface of the paper. Therefore, in addition to the treatment referred to, the paper must be sized. The process may be applied to wood, leather, or any fabric that can be sized.

PREPARATION OF THE PAPER.

The first consideration is the choice of a suitable paper, and for experimental work there is nothing better than Whatman's hot-pressed drawing paper. Any pure paper may be employed, avoiding those with glazed surfaces and those which appear to be sized with impure gelatine. Excellent results have been produced on ordinary typewriter paper. The next point to consider is as to whether the chloride or the silver solution shall be employed first. When a solution, say sodium chloride, is added to silver nitrate, silver chloride and sodium nitrate are

formed, as expressed by the equation



Atomic weights: $\underbrace{108 + 14 + (16 \times 3)}_{170} + \underbrace{23 + 35.5}_{58.5}$

Molecular weights: $\frac{170}{340}$ is to $\frac{58.5}{117}$

or as $\frac{2}{340}$ is to $\frac{2}{117}$

This is the action which takes place in the making of the paper. Chemists have found that certain substances react always in the same proportions to form compounds, without relation to the actual weights of the substances that may be in contact. To make this clearer, take the atomic weights in the equation just given. These are shown by the top row of figures, and the totals give the molecular or combining weights. Thus, it will be seen that 340 parts of the one always react with 117 parts of the other, so that if equal quantities by weight of each were used, one substance would be in excess of the other. When silver chloride is exposed to light, chlorine is liberated; this can be proved by taking a sample of the substance and noting the smell of chlorine gas given off on exposure to light. When some substance is present which is an absorbent of chlorine, the decomposition takes place more readily, for two agencies are at work—the light tending to liberate the chlorine and the absorbent ready to combine with the chlorine. Now supposing the substance which is in excess to be chlorine, the action can only proceed slowly, for chlorine is not an absorbent of itself. If the substance in excess be silver nitrate, the chlorine is readily taken up; therefore the silver nitrate, or sensitising solution, must be used last, so that the chlorine may all be used up, and the solution remaining on the surface of the paper which is in excess of that actually necessary for the formation of silver chloride should be silver nitrate.

METHOD OF SIZING AND SALTING.

The operations of sizing and salting the paper may be conveniently carried out together, and for this purpose the following bath is employed:—Crystallised am-

monium chloride, 130 grains; recrystallised sodium carbonate, 200 grains; citric acid, 60 grains; arrowroot, 180 grains; water, 1 pint. This formula gives the normal amount of chloride to be used, and it is doubtful if the worker will ever have occasion to alter it. Modifications of this, however, may sometimes be made with advantage. For example, the chloride may be reduced to one half the amount when printing from hard negatives, or increased to double in the case of weak, flat negatives. Mix the arrowroot to a thin paste, and pour it into 15 oz. of water. Place this on a stove, and heat gently almost to boiling point; the solution should not be allowed to boil, as this is apt to fill it with bubbles. When the solution is quite clear, it may be removed from the stove and placed aside to cool. In the meantime, place together in a small vessel the three quantities of crystals, and pour over them what remains of the water. Cold water should be used, and they should be allowed to dissolve without agitation. The combination of the sodium carbonate and citric acid makes an effervescing mixture, which if stirred would overflow and probably become unmanageable. When the solution of arrowroot is cool, pour into it the dissolved crystals. The whole of the solution may then be poured into a clean flat dish, when it will be ready for use. Hold the paper up to the light so that the watermark reads correctly, that side nearest to the eye being the one to be sensitised. Lay the paper face downwards and make a pencil mark from corner to corner, so that the right side may be easily recognised. The paper should be kept scrupulously clean. Be careful to lay it upon a clean sheet of blotting paper, not upon a bench which may have been used for other operations. Cut the paper according to the size of the dish being used, and float it upon the solution for five minutes; then draw slowly off over the side of the dish and dry evenly. The paper while in this condition is ready for sensitising, and will keep indefinitely, so that it is usual to prepare a sufficient quantity up to this

point, as the salting and sizing solution will not keep. After a time, the gelatinous part of the solution slowly sinks to the bottom, it being thus rendered useless.

PREPARING AMMONIUM CHLORIDE.

It is essential that the chemicals used in sizing and salting shall be absolutely pure. The most likely to be impure is the ammonium chloride. This may be prepared, specially, as follows: A concentrated solution of ammonium sulphate is mixed with common table salt, well agitated, and boiled down. Crystals of sodium sulphate are formed, and should be removed. Evaporation is continued until the fall of coarse crystals ceases and the liquid begins to be covered with an opalescent film of salt. The liquid is allowed to cool in leaden vessels, and the crystallising ammonium chloride is washed first in a solution of pure salt and then in water. Ammonium chloride may also be prepared by neutralising crude ammoniacal liquor with hydrochloric acid, and evaporating to obtain the salt. The crude ammonium chloride is dried in layers till the water and free acid are driven off and the tarry matters carbonised. The wasted salt is then carefully sublimed. If the temperature during this operation is too high, the solidification is disturbed, and if too low the sublimate is loose and not transparent. Small quantities of ammonium chloride may be purified for photographic use from the commercial sample as follows: Support on a tripod over a Bunsen burner an iron vessel containing the sal-ammoniac. Over the vessel place a thin card perforated with needle holes, and over this card place an inverted dish or pan, in which the purified salt is to be collected.

SENSITISING SOLUTION.

The sensitising bath is citric acid, 240 grains; silver nitrate, 600 grains; distilled water, 10 oz. The character of the resulting pictures depends upon the quantity of silver nitrate present, or on the strength of the bath in grains per oz. An experiment will be found valuable in

this connection. Take a small quantity of paper coated with albumen, and immerse it in a 1 per cent. solution of silver nitrate. In a short time it will be found that the albumen is dissolved off the paper. A 14 per cent. solution, or 60 grains per oz., is found most satisfactory, the point to remember being that a strong solution of silver nitrate coagulates the organic matter, whilst a weak one dissolves it. Moreover, a weak solution of silver nitrate leaves less silver on it free or in excess on the surface of the paper. In any case, the solution should never be below 40 grains per oz. The object of the citric acid is to prolong the keeping qualities of the paper. Paper prepared with silver nitrate alone darkens spontaneously without exposure to light. Plain salted paper prints out to a beautiful purplish brown colour, varying according to the sizing matter used. It requires considerable overprinting compared with P.O.P., as the image loses in intensity in the fixing bath. The prints may be toned as described in the section on Toning, or may be simply washed and fixed, when they should be of a pleasing warm sepia colour. The paper may also be prepared with starch or gelatine, and with various chlorides. The following are selected formulæ:

ALTERNATIVE FORMULÆ.

To size with gelatine, proceed as follows: Take 200 grs. of Nelson's No. 1 gelatine, and dissolve in a water bath in 18 oz. of water. Allow to cool, and then add 160 grs. of ammonium chloride dissolved in 2 oz. of water. The paper is floated on this, or immersed, as preferred, for five minutes. The prints prepared in this way, however, are not quite so satisfactory. Another method employed by some workers is as follows: Take 60 grs. of starch, and mix into a thin paste with cold water; then raise to boiling point in 18 oz. of water. When cool, add 150 grs. of sodium chloride dissolved in 2 oz. of water. The paper is treated in the same way, and may be sensitised in the bath given above, or in a neutral bath as described for use in the albumen process (p. 171).

THE ALBUMEN PROCESS.

The albumen process, or the ordinary silver process, as it is usually called by professional photographers, is capable of giving most pleasing results, and deserves to be far more practised by amateurs. In quality of gradation and richness of colour it more than holds its own when compared with its rival, the gelatino-chloride process. Although spoken of frequently as old-fashioned, it is still largely used. The paper will stand fairly rough handling, as the sensitive coating is practically insoluble even in warm water; it is free from disagreeable gloss; it gives a softer set of gradations; and it is not liable to double-toning. On the whole, the albumen process is cheap and easy to work, and gives highly satisfactory results with negatives showing fine detail. Over-exposed negatives and negatives lacking in density cannot be successfully printed in albumen, and this probably accounts for the fact that it has been superseded by gelatino-chloride to such a great extent. Photographers who prefer an enamelled glaze on their pictures, and who desire an extreme contrast or brilliancy, may not find the albumen process please them so well as the gelatino-chloride process. Albumen paper can be purchased. Some brands are obtainable in cut sizes. The paper keeps extremely well, but gives off a rather offensive odour when stale. The chemicals necessary are few, if the paper is purchased ready sensitised, the chloride of gold, hypo., and borax being all that are required. This borax is in the form of a white powder, and dissolves freely in warm water. The acetate bath may also be used if the paper is treated first of all with a solution of soda carbonate (see section on "Toning with Gold and Platinum").

PREPARING ALBUMEN.

The albumen is prepared as follows: First collect the whites of about ten eggs; this is done by breaking them one by one on the edge of a basin. Placing the thumbs in the dent made in the shell,

pull the egg smartly in two, holding the thumbs uppermost. As the egg comes in two, take care that the yolk is in one half of the shell together with the small particle of insoluble matter attached thereto. Pour this backwards and forwards from one half shell to the other over the basin. In this way the white will gradually separate itself and fall into the basin below. Now, with an egg-whisk, beat the whole into a froth. The whites of ten eggs provide about $\frac{1}{2}$ pint of albumen. Great care must be taken that no part of the yolk finds its way into the albumen. The albumen must be neither strongly acid nor strongly alkaline. When fresh, it is faintly alkaline, but turns acid in keeping. If alkaline, the albumen is more liable to dissolve; while if acid, it will cause difficulty in toning.

SALTING THE ALBUMEN.

The albumen must next be salted, and the experience gained in the "plain salted" process will be of service. It is said that anything between 5 and 20 grains to 1 oz. may be used; about 15 grains to 1 oz. is a good proportion. Take, therefore, 150 grains of ammonium chloride; dissolve in $1\frac{1}{4}$ oz. of cold water, and add it to the albumen. Other chlorides may be used, such as sodium chloride, potassium chloride, or barium chloride. If these are employed, then the proportions used should be in exact ratio to their chemical equivalents. This is estimated by finding the proportion the weight of chlorine it contains bears to the full molecular weight. Sodium chloride, we have seen, is 58.5, potassium chloride is KCl, or

$$\frac{39 + 35.5}{74.5}$$

Barium chloride is $\frac{\text{BaCl}_2 + 2\text{H}_2\text{O}}{244}$, or

$$244.$$

Thus in the first case, out of 58.5, 35.5 is chlorine, whilst in the last only 71 parts out of 244. So that 244 parts of the latter will be required to equal 117 parts of the former. On the whole, however, chloride of ammonium is to be preferred. The same

precaution as to purity must be taken as in the "plain salted" process.

MIXING THE ALBUMEN AND CHLORIDE.

In order to mix the chloride properly, it is essential that the fibrous nature of the albumen should be destroyed; therefore another violent beating with the egg-whisk is necessary, until the albumen

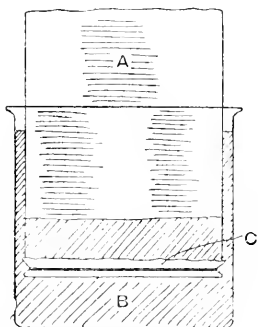

Fig. 255.—APPARATUS FOR UPWARD FILTRATION.

is reduced to a perfectly limpid state. Having allowed it to settle, place a small sponge in the neck of the glass funnel and let the solution filter slowly through. The solution must be free from bubbles, so that the funnel should touch the side of the vessel into which it filters, the fluid running down the side. The method known as upward filtration has also been recommended, and certainly has its advantages. Take an ordinary glass jam jar, and trace a line round it about $\frac{1}{4}$ in. from the bottom with a red-hot poker; this should cause the glass to crack, and if smartly done the crack will follow the direction of the poker, when all that is necessary further is to hit the jar a sharp blow, and the bottom will drop out, leaving the bottomless jar with a ring round its edge, as shown in Fig. 255. Over this is tied two thicknesses of washed muslin *c*. The albumen is placed in a vessel *b* just large enough to admit the upward filter. The filter has now to be placed muslin end downwards in the liquid, when the weight of the jar forces the solution through the muslin. One ounce of this

solution is sufficient to coat two sheets of paper 22 in. by $17\frac{1}{2}$ in.

PAPER TO BE USED.

A perfectly pure paper is not quite so essential as in the process previously described, the chief consideration being that it is of a good colour and sufficiently opaque; that is to say, when laid over a sheet of newspaper, the reading matter must not show through. Provided the paper fulfils these conditions, its thickness is of no consequence. Suitable papers may be obtained in small quantities from the dealers—the usual size is 22 in. by $17\frac{1}{2}$ in.; but if the size referred to

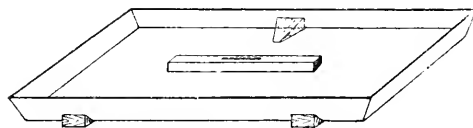

Fig. 256.—LEVELLING THE DISH.

cannot be procured, any convenient dimensions may be taken, using the proportionate quantity of albumen. Rives and Saxe papers are the best for this purpose, but are not readily obtainable uncoated. Rives is a thin paper, and Saxe a heavy paper suitable for larger sizes; the bank post papers are also suitable.

COATING THE PAPER.

When filtered, the albumen should be poured into a flat dish a few inches larger each way than the paper to be treated, and levelled up by means of three wedges (see Fig. 256) so that an even layer of albumen is presented to the print. There should be a depth of at least $\frac{1}{2}$ in. of solution over every part of the dish. This should be arranged upon a bench close to a fire, as the gloss of the paper depends upon the heat. The temperature should be about 90° . The higher the temperature, the more brilliant will be the glaze, and consequently the more brilliant the print. If the temperature is allowed to fall much below 90° , the paper will have a dull appearance, and the image be

somewhat sunken. This, however, is not a serious defect, as where brilliancy is desired other processes are available. It will be remembered that, in the "plain salted" process, the heavier the sizing the more brilliant the picture, owing to its being kept more on the surface of the paper. When the temperature is high, a heavier coating is obtained on the paper with a like result. Both single and double albumenised paper are obtainable; the latter having a heavier coating resulting

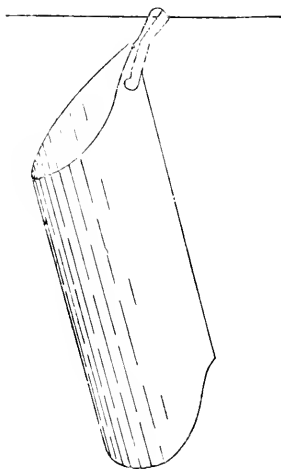

Fig. 257.—METHOD OF DRYING PAPER.

from two applications. The right side of the paper is then determined as explained on p. 165. Moisten the back with a damp sponge lightly, and float it on the albumen, as described for sizing on p. 165.

BUBBLES.

Bubbles may be coaxed to the edge of the paper by gentle pressure without lifting the paper off the solution. Allow the paper to remain for one minute, and draw slowly off by two corners of one side and hang up to dry over a string as shown in Fig. 257, wooden clips being used to suspend the paper. Should bubbles be found adhering to the paper when it is withdrawn, they should be removed, and the paper at once re-floated for a minute. Otherwise they would remain as almost

insensitive spots on the paper. Floating for a longer time seems to have no injurious effect, but if extreme brilliancy is desired the paper should not be left in the solution too long. In coating on a large scale, it is best to have two dishes of albumen, so that while one sheet is floating another may be laid down or taken off. The paper may also be drained and dried over wooden laths, as shown in Fig. 258; but this is not advised, as it is liable to cause unevenness. Manufacturers usually submit the paper when dry to heavy pressure in a rolling press, to make the coating more even and to improve the gloss.

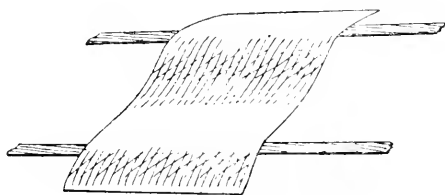

Fig. 258.—DRYING PAPER ON LATHS.

Professional photographers never albumenise their own papers nowadays; it is usually purchased ready for use. It will keep a considerable time in this condition, but must be rendered sensitive before printing.

STRENGTH OF SILVER AND SALTING BATHS.

It has been already pointed out that a sufficient quantity of silver nitrate in proportion to water must be present, in order to ensure the formation of the organic salt of silver (in this case the albuminate), and in this connection it must be noted that the organic salt is much slower in formation than the silver chloride; so that sufficient time must be allowed for this, or less of the organic salt and more of the chloride will be formed, with the result that an image of a different colour would be produced, which would, moreover, be readily dissolved in the hypo. bath—a state of things to be strictly guarded against, both on account of the loss of time occasioned and the uncertainty of the result. The stronger

the silver bath the more organic salt will be formed, whilst if the solution be weak very little will occur; in addition to which there is the danger of the albumen being dissolved off the paper, still further lessening the chances of its formation. From this it will be gathered what an important connection exists between the strength of the silver bath and the strength of the salting bath. The more salt present in the latter the greater must be the strength of the former.

MAKING UP THE BATH.

The time of floating is also governed by the strength of the bath. The object being to coagulate the albumen, it must be borne in mind that in floating the paper on the

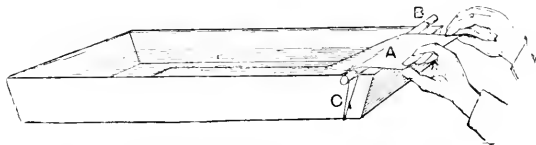

Fig. 259.—WITHDRAWING SHEET FROM BATH.

silver bath an insoluble coating is soon formed on the top which is not readily permeable to the solution, and that some time must elapse before the next layer can be formed, the difficulty of penetration increasing as the operation goes on. On the other hand, with a weak solution the formation of such organic salt as is possible goes on readily and evenly throughout the film. Thus the length of contact with the silver solution will depend upon the strength of the bath; the stronger the bath the longer the floating, and *vice versa*. When distilled water is not available for making up the bath, rain water or pure spring water may be used; any precipitate formed should be allowed to sink to the bottom, and the clear solution decanted off. It should be borne in mind that this will slightly weaken the solution.

ALTERNATIVE FORMULE FOR SENSITISING.

Take 200 grains of gelatine and dissolve in 18 oz. of water; take 200 grains of ammonium chloride and dissolve in 2 oz. of

water. Mix the two solutions together at as low a temperature as possible, and the solution is ready for use. Another formula used with success is as follows: Take 230 grains of starch and mix into a thin paste with cold water; then make up to 18 oz. with hot water. Dissolve 300 grains of soda chloride in 2 oz. of water, together with 100 grains of citrate of soda, and mix with the above. The advantage of this over the other formula is that the paper keeps so much better when sensitised; the

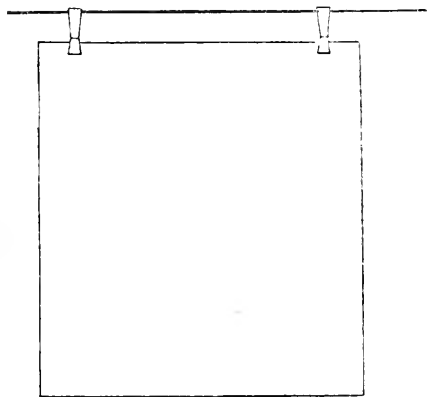

Fig. 260.—DRYING WITH TWO CLIPS.

reason of this will be understood from the explanation already given.

HOW TO SENSITISE.

The sensitising bath, when made up, is poured into a perfectly clean dish reserved for the purpose. The paper is then taken by two diagonally opposite corners, and lowered into the solution, being allowed to remain for three minutes. When it has been down a minute, one corner should be raised and carefully examined for air-bubbles, which, if discovered, should be destroyed with a glass rod. When the time of floating has expired, the paper A is taken by two corners and drawn over a glass rod B placed across the dish, as shown in Fig. 259. It is advisable to tie down the rod with a piece of string C, passing around both ends and under the dish. This prevents the rod being accidentally knocked off. In this way only a minimum of solution is taken from

the bath. It is then fastened by wooden clips to a string to dry (see Fig. 260). This is preferable to using only one clip, and makes the coating more even. A piece of blotting-paper is laid beneath to catch the drippings, being afterwards placed, with the print cuttings, in the residue box, so that the silver may be recovered. Rubber finger stalls save staining the fingers. If the fingers become stained, rub over with hydrochloric acid and immerse in a clean fixing bath, not one which has been used for fixing negatives, as by this the stains will be intensified.

SENSITISING SILK, WOOD, ETC.

The fabric should be well washed, dried, and then ironed flat. It is then advisable to strain it lightly over a wooden frame or a piece of cardboard, but this is not absolutely necessary. In sizing and salting the fabric, it is best to immerse it in the solution; the thinner the material, the longer it should be immersed. In some cases it will be an advantage to size the fabric first of all in a 2 per cent. solution of gelatine, and then to use the sizing and salting bath recommended. In nearly all respects the fabric may be treated in the same way as paper, except that the immersion in this bath should continue for seven minutes. Sensitising and printing is done as usual. The fabric should be well washed, and may finally be treated with hot water to dissolve out all the size; but this is not a good plan, as it gives the image a sunken appearance, a defect extremely difficult to avoid in any case. When washed, the fabric may be blotted off, and ironed dry between clean blotting-paper. Wood is salted and sized as usual, allowing longer for the process according to the porous nature of the wood. In sizing, the wood may generally be floated on, but it must be done very carefully and slowly, to avoid unevenness. To sensitise, it is best to support the wood face downwards upon two glass rods *A A*, as shown in Fig 261, and then to pour in the sensitising bath until it just reaches the surface. In choosing a fabric, commence on a thin one, as this is easier to deal with. Fine linen gives excellent results.

TESTING AMOUNT OF CHLORIDE IN PAPER.

When the paper has been purchased ready albumenised and salted, it is necessary to know the amount of chloride present in order to make full use of the facts just considered. The manufacturers give full directions as to the best sensitising bath, and generally it is as well to follow them. The amount of chloride present can only be found by quantitative analysis, which is not a very difficult operation in the present instance. It may be estimated by dissolving out the chloride

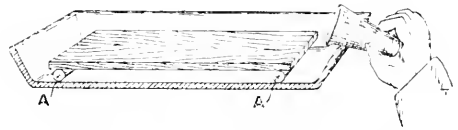

Fig. 261.—METHOD OF SENSITISING WOOD.

from a sheet of paper by immersion in alcohol, evaporating the solution, re-dissolving in water, and adding a solution of silver nitrate of known strength until no further precipitate is formed. The quantity of silver nitrate used will indicate the amount of silver chloride in the paper.

SENSITISING.

The sensitising process is similar to that described in the paragraph "How to Sensitise," p. 170; but there are certain exceptions which should be mentioned. The bath to be employed should be in a neutral condition. If acid, it will give poor flat prints. The strength of the bath should be 50 grains per oz. for average negatives. The strength is governed by the contrast desired in the picture, and the solvent action liable with a weak solution of silver nitrate, as previously explained. For hard negatives, the solution may be allowed to fall to 30 grains per oz., whilst with weak negatives the strength of the bath may be raised to 50 grains per oz. It is not advisable to tinker with the bath; the best plan is to have the bulk of the solution made up for average negatives, and about 10 oz. of each of the varied solutions in

addition, which will be sufficient for floating paper in small pieces, say up to 12 in. by 10 in. or 15 in. by 12 in., if a dish with a perfectly flat bottom is used. Where only a small quantity of solution is to be used the shallower the dish is the better, as otherwise the paper is a little difficult to get at. The reverse side of a glass bottom dish may be used with care. To make up sufficient for general use, it is usual to dissolve 1,750 grains of pure re-crystallised silver nitrate in 30 oz. of distilled water. Take care, in weighing it up, that the scale pans are scrupulously clean, or that a filter paper is placed in each

into the solution; if it turns blue the solution is alkaline, but if it remains red it is either acid or neutral; to ascertain which, tear a leaf from the blue litmus book, and immerse this in the solution; if it is acid, the paper will turn red, but if neutral it will remain unchanged. Albumen paper is found to give the best results when not absolutely dry, and for this purpose it has been recommended (when working abroad in a very dry atmosphere, or in extremely hot weather in this country) to add 50 grains per oz. of some deliquescent salt, such as ammonium or sodium nitrate, which, crystallising out on the surface of

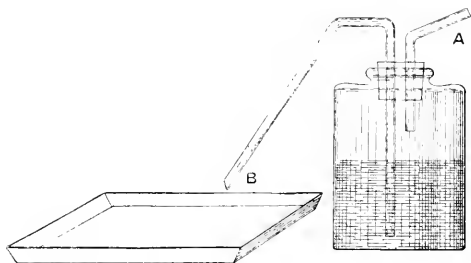

Fig. 262.—ARRANGEMENT FOR CLEARING BATH.

scale, as any foreign matter in a neutral bath is sure to cause trouble.

TESTING THE SOLUTION.

To ensure the bath remaining in a neutral condition, it was at one time best to have a little carbonate of silver in it, which is added by putting in a few drops of a 5 per cent. solution of pure sodium carbonate and carefully testing with litmus paper. Latterly, however, the commercial albumen paper does not seem to agree with this treatment. Prints obtained with such a bath are apt to be mealy and flat. Litmus is a vegetable product which, on combining with acids or alkalis, even in the most minute quantity, changes immediately in colour. Alkalis cause it to change to blue and acids to red. Litmus paper is done up in little books. To test a solution, a leaf of, say, the red book, is pulled out and dipped

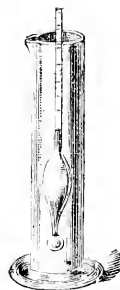

Fig. 263.—ARGENTOMETER.

the paper, keeps it always in a slightly damp state. The object of this is to absorb the liberated chlorine and prevent its acting on the albuminate. On the whole, however, this is best omitted. Some commercial papers are apt to become too dry, but by keeping in a *slightly* moist atmosphere for 12 hours a similar result may be obtained.

KEEPING THE BATH IN ORDER.

Nothing has been said so far as to the difficulties of keeping the silver bath in order. A moment's consideration will show the risks of deterioration, and the need for frequent examination. Every sheet of paper floated upon it introduces some foreign matter, however small, whilst each sheet, extracting as it does a quantity of silver, alters the strength of the bath. Especially is this the case with a neutral bath, the one described on p. 170 being far less liable to go wrong. As the

bath becomes charged with organic matter, it gradually turns to a dirty brown, and in such condition is incapable of giving satisfactory results. This should, therefore, be removed as soon as possible.

CLEARING THE BATH.

A variety of methods are adopted for this purpose; the best is to expose the bath to strong daylight—sunlight if possible—for about a day, when the organic matter will reduce a small portion of the silver, which falls to the bottom of the vessel. The clear solution may then be decanted off, or syphoned by means of a jar fitted with bent tubes, as shown in Fig. 262. This apparatus consists of a wide-mouthed jar fitted with a bung, which is bored to accommodate the bent tubes A and B. The bent tube should reach almost to the bottom of the jar, its exact position being dependent upon the amount of precipitate present, as it should be just above this. It is easily raised to the proper height. By blowing down tube A the solution will be forced out at B, and will continue to run until the bottle is empty. The objection to this method is that the bath must be put out of use for a whole day; but where two baths are kept going, in case of accidents, this will not prove a serious inconvenience. A quick way to bring down the organic matter is to add a very small quantity of hydrochloric acid. This will result in the formation of silver chloride and nitric acid, thus:—



(Silver nitrate and hydrochloric acid form silver chloride and nitric acid.) After this addition the solution must be tested with litmus paper, even if silver carbonate has been present in the solution. If showing an acid reaction, sufficient soda carbonate must be added to neutralise it. A better method, and one in practical use in most establishments in winter, is to add a little Kaolin or China clay, which carries down the finely divided precipitate. See that the Kaolin is pure; if adulterated it is useless and injurious.

TESTING STRENGTH OF BATH.

Whichever of these methods is adopted, the bath must be tested afterwards to discover its exact strength, and for this purpose an argentometer (Fig. 263) is used. This is an instrument for taking the specific gravity of the solution. It consists of a



Fig. 264.—CONTINENTAL PATTERN ARGENTOMETER.

glass tube which is in three compartments, the top one containing an ivory scale graduated downwards from 0 to 80. When placed in a glass beaker (the most convenient thing for the purpose is a pint or litre cylindrical measure) the hollow bulb is drawn under the surface by the weight of the mercury in the bottom compartment, and sinks until the figure 0 is level with the surface of the water—the scale having been placed to read thus when an amount of water equal to the weight of the mercury has been displaced. If, say, 10 grains of silver nitrate were dissolved in each ounce of water, the argentometer would sink only to 10, or if immersed in the bath described when newly prepared it

will float at a number exactly equal to the quantity of silver contained. If, however, the soluble nitrates referred to have been added to the bath, it will be seen at once that the readings of the argentometer are incorrect, and this error must be allowed for. Generally speaking, the instrument is sufficiently accurate for all practical purposes. The continental pattern, which is graduated differently, is shown by Fig. 264.

REGULATING THE SOLUTION.

The amount of silver nitrate to be added if the bath is too weak, or the extra amount of water if it is too strong, is then very easily calculated. All that is necessary is to ascertain the bulk of the solution, and multiply the number of ounces

coloration, the prints produced by it, after even about two days, being very weak. To avoid this trouble, it is usual to "fume" the paper when more than a day old, or to impregnate it with ammonia fumes. The object is to absorb the chlorine spontaneously liberated and prevent discolouration or flatness. This operation is carried out by means of an ordinary wooden box (see Fig. 265) opening from the side as shown. It has rails at A, over which run light wooden frames covered with clean white muslin, B. Beneath the lowest one is placed an evaporating basin C containing about 1 oz. of liquid ammonia. The sheets of paper are laid face up on these frames, and the box is closed by means of the folding flap D, and fastened by the turn-button E; the paper remains in the fumes for about ten minutes. Instead of using this method some printers place sheets of blotting-paper soaked in ammonium chloride solution and a similar quantity soaked in lime-water in contact, so that ammonia is liberated by double decomposition. The paper kept under pressure will keep much longer, and if kept between sheets of blotting-paper which have been soaked in a 5 per cent. solution of citric acid it will remain unaltered—say a fortnight or more. When an acid sensitising bath is used as described on p. 170 fuming is unnecessary, and the paper keeps well. This is the process employed by manufacturers of ready-sensitised paper, which keeps for a considerable time. As a further preservative, it is usual to float the back of the paper on a bath of citric acid, the strength of the solution being about 20 grains per ounce; or it may be floated, sensitive surface uppermost, on a solution of 5 oz. of nitrite of potassium to 100 oz. of water. When dry, the paper is rolled up, coated side out, and wrapped in blotting-paper soaked in the nitrite of potash solution, and dried. This method may be employed also with paper floated on a neutral bath. The objection to ready-sensitised paper is that its acid condition limits the available tones to such as are not very pleasing; with proper treatment, however, this seldom proves a serious drawback. Instructions for dealing

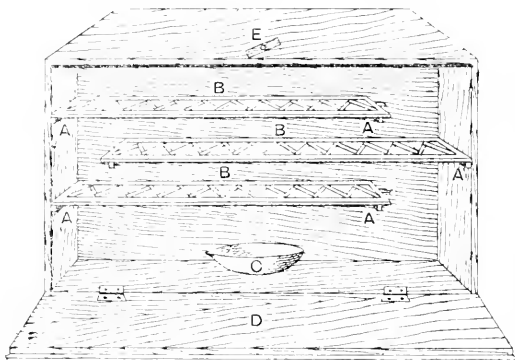

Fig. 265.—FUMING BOX FOR ALBUMEN PAPER.

by the number of grains per ounce. Thus, suppose the argentometer indicates a strength of 52 grains per ounce, and a bath of 60 grains is required, whilst the total bulk of solution is 20 oz. Multiply the number of ounces, 20, by number of grains, 52 = 1,040. Now, the quantity of silver nitrate required in 20 oz. is 1,200 grains to give a strength of 60 grains per ounce, so that subtracting 1,040 from 1,200 gives the number of grains which must be added, namely, 160.

PRESERVATION OF SENSITISED PAPER.

Paper sensitised in a neutral bath is extremely liable to deterioration by dis-

with it to the best advantage will be given later. The toning, fixing, and washing of albumen paper are described in a separate section.

GELATINO-CHLORIDE PROCESS.

The experience gained in the study of the "plain salted" process will be of great assistance in the working of other silver processes, as the same principles underlie all silver printing. In fact, a print upon plain paper heavily sized with gelatine resembles very closely, both in appearance and in constitution, a matt surface gelatino-chloride print. Especially is this the case if the bath is prepared so as to leave silver citrate in excess on the paper instead of silver nitrate. The gelatino-chloride glazed paper is viewed with considerable disfavour—one might almost say contempt—by leading artistic photographers; but it is of great value where extreme detail and microscopic sharpness is desired, and is the process chiefly used by amateurs in commencing photography. The high glaze and somewhat hard effect of the "glossy" variety are, however, serious defects from an artistic standpoint. For the best results, a soft negative—in fact, one which would give a flat effect in other processes—is required. There are, nevertheless, certain makes of paper with which a somewhat stronger negative may be used. It is as permanent as any other print-out silver process, while for a negative that is weak from under-exposure there is probably none better. The gelatino-chloride process proper is an emulsion process. A paper of sufficient strength and opacity is coated with an emulsion of either silver chloride or silver citrate, the latter being now almost entirely used, as the presence of free silver nitrate with gelatine is opposed to a successful result.

PREPARING GELATINE EMULSION.

To compound such an emulsion, take 100 grains of any hard pure gelatine, place it in a jar or beaker, and cover with distilled water. If the sheet gelatine is used, it is more convenient to cut it into narrow strips. After allowing it to stand for a few moments, rinse it round and

throw away the water. Then pour upon it a second quantity of water, and allow the gelatine to swell. The object of the first watering is to ensure its being perfectly clean. About $2\frac{3}{4}$ oz. of water may be allowed to 100 grains of gelatine. Next take 30 grains of citrate of soda, and dissolve it in $\frac{1}{2}$ oz. of warm distilled water. Place the gelatine and water in a water bath, as described on p. 65, until completely dissolved. Test the mixture by drawing a glass rod through it, as the solution, while appearing perfect, may contain thick slimy veins of gelatine not completely dissolved, which if present will attach themselves to the rod. When the dissolving action is complete, the citrate solution is added little by little with much stirring. Now take 45 grains of silver nitrate and 80 grains of citric acid, and dissolve in 6 drams of distilled water. Warm the solution slightly, and then spray it into the gelatine solution as described on p. 63. The emulsification being accomplished, it may be dealt with according to the instruction given in the section on Plates and Films, pages 64 to 67. The temperature of the solution must not be too high during the emulsification, or decomposition is liable to set in; the solution should be only just warm enough to ensure its being thoroughly dissolved. Keeping gelatines in solution at a high temperature destroys their power of setting. The actual temperature will, of course, depend upon the kind of gelatine used. Barker's formula for printing-out emulsion is: Gelatine (Nelson's No. 1 and Coignet's equal parts), 175 grains; chloride of ammonium, 18 grains; Rochelle salts, 50 grains; nitrate of silver, 75 grains; alcohol, 4 drachms; water, 5 oz. Heat to 100° F., and allow to remain at this temperature, after all is dissolved, for ten minutes.

TESTING GELATINE.

The selection of a suitable gelatine is a most important matter. A good plan is to obtain a variety of samples, and test their melting point. The following is a simple and ingenious method of testing gelatine. A solution is made of each of

the gelatines under examination, and a small layer taken by means of a paper tube worked on the principle of a pipette. That is to say, a tube having about $\frac{1}{2}$ in. bore is lowered into the solution to the depth of

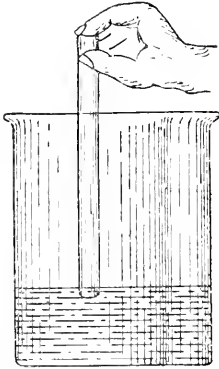

Fig. 266.—TAKING SAMPLE OF GELATINE.

about $\frac{1}{4}$ in., the top of the tube being closed with the tip of the finger to make it air-tight (see Fig. 266). It is then rapidly withdrawn and laid over one side of a flat-sided vessel, and the finger removed (see Fig. 267). This deposits the gelatine in a form somewhat resembling a gelatine lozenge on the side

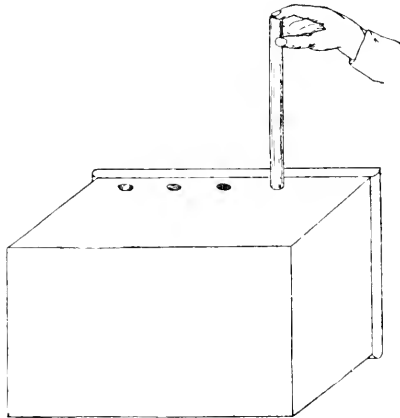

Fig. 267.—LAYING DOWN GELATINE SAMPLES.

of the vessel, to which it adheres firmly. Each sample of gelatine is treated in the same way, and the vessel is then filled with water, and either placed over a stove or supplied with hot water from the tap—

the first method being the better of the two. Small thermometers are now placed against the inside of the vessel, as near as possible to each disc of gelatine, and the water very slowly heated. The temperature at which the gelatine melts, which is indicated by its detachment from the side of the vessel, must be carefully noted. Against each sample of gelatine the name should be written, to prevent possibility of confusion. This experiment will not only enable a rough classification into hard and soft gelatines to be made, but will determine the exact melting temperature of the different varieties used. A mark should be made on the vessel to

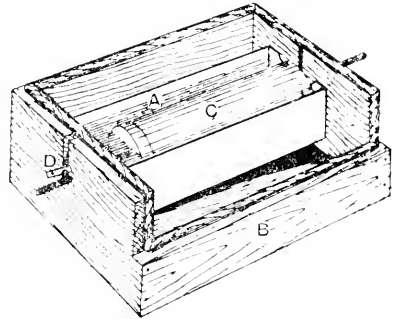

Fig. 268.—TROUGH FOR HOLDING EMULSION.

show clearly when the gelatine disc commences to move, and the hot air from the burner should be shielded from the outside.

TROUGH FOR HOLDING EMULSION.

The emulsion, after filtering, washing, etc. (the washing of the emulsion, etc., is carried out as described on p. 61), is placed in a trough A (see Fig. 268) suspended or standing in an outer vessel B forming a water bath, over which a roller C is fixed. The construction of such an apparatus suitable for experimental purposes is a simple matter. First make the lower vessel. This may be cut from a sheet of tin of the pattern shown by Fig. 269, and soldered into the shape shown by Fig. 268. Within this is placed a glass or porcelain trough (the troughs used for damping purposes would answer) or, if this is not



EXAMPLE OF BLOCKING OUT FIGURE AND INSERTING BACKGROUND

available, a dish may be tilted up as shown in Fig. 270. Cut a length of glass tubing about 2 in. in diameter by filing it well all round, and then tapping it softly with a piece of wood until it breaks off. If the tubing is not obtainable of sufficient diameter, a cylindrical lamp-glass, as used upon incandescent burners, may be employed, and answers equally well. Now choose two cork bungs exactly fitting this tube, and close it at each end, having first bored a hole in the exact centre of each cork of sufficient size to take tightly a glass rod, *A*, which passes from end to end. A catch may be fixed at *D* to hold the rod firmly in position. The rod is introduced under the slot *C*

surface of the solution, and in doing so receives a layer on the paper. It is then hung up, or if long, passed over rollers to dry, and when dry is ready for use. The toning, fixing, and washing of these papers are dealt with in a separate section.

GLOSSY AND MATT PAPERS.

Gelatino-chloride paper is made in two varieties, glossy and matt, the former giving an objectionable glaze, and the other a soft and pleasing surface resembling plain salted paper. The matt paper is prepared and dealt with (with the exception of enamelling) in precisely the same way, the difference of surface resulting from difference in the emulsion, arrow-root being generally used in preference

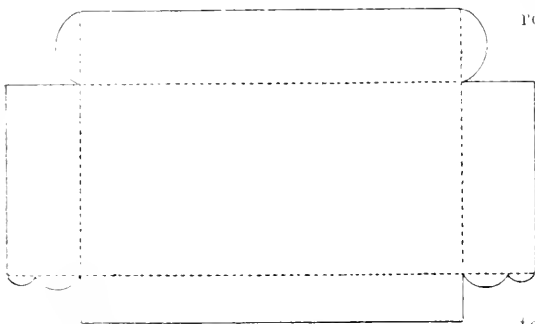

Fig. 269.—PATTERN FOR TIN WATER BATH.

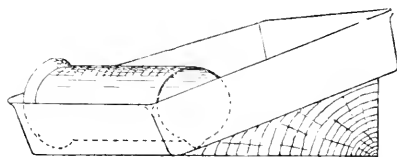

Fig. 270.—MAKESHIFT ARRANGEMENT FOR COATING PAPER.

on each side, and held in by the turn-buttons. The apparatus is now ready for use. The use of a cylindrical litre measure held by an assistant over the side of a dish tilted on blocks has been suggested (see Fig. 270); but this is not a convenient arrangement, as it necessitates two persons working together.

to gelatine. Manufacturers keep their formulæ strictly secret, and particularly has this been the case with reference to matt emulsions. So far, it has been assumed that this process is being worked upon paper, which may, of course, be of different grades and surfaces, but it is equally applicable to other substances—glass, for example.

COATING THE PAPER.

GLASS AND OPAL PLATES.

The paper, cut to correct width, is wound tightly round the roller and this is then inserted. The lower vessel having been placed upon blocks over a small easily regulated flame and filled with water, the emulsion is poured into the inner vessel to a height just sufficient to reach the roller and no more. The paper is then pulled up tightly, and the roller allowed to revolve over the

It is not certain whether glass plates are still obtainable, but they are certainly little used. Nevertheless, they are capable of giving excellent results as transparencies, optical lantern slides, etc. The reduced silver being in an extremely fine state of division, the grain is excellent. Opal may also be coated, and the tones obtainable seem particularly pleasing upon that base. Unfortunately, the lack of permanency is a serious drawback, so that

they are never likely to rival opals produced by the carbon process.

A USEFUL PRINTING FRAME.

Printing-out upon rigid supports has a further disadvantage—namely, that the image cannot be conveniently examined to watch its progress. A frame was introduced some years ago by means of which this obstacle was overcome. It consisted of a frame recessed to take the negative, over which was fitted a similar frame recessed to take the plate and provided with turn-buttons. The two halves of the frame are shown in Fig. 271, by reference to which it will be seen that the negative surface comes flush with the surface of the frame, so that the plate may be taken

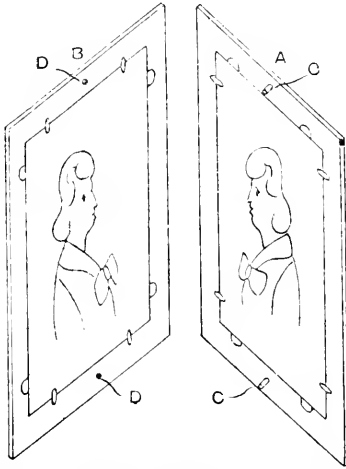

Fig. 271. — PRINTING FRAME FOR GELATINO-CHLORIDE PLATES.

to be in absolute contact. Further, frame A is provided with two pegs c fitting two holes D in frame B, and thus ensures the plate always being replaced on the exact part of the negative before printed from, and so preventing a blurred image. The advantage of such an arrangement will be chiefly felt when a picture is required upon opal, of a tone to match a silver print, yet needing combination printing or the introduction of a sky. Every practical worker knows what an advantage it is to be able to examine the image from

time to time in combination printing, so that the point need not be enlarged upon. In vignetting, also, the frame will be useful, as considerable practice is necessary before a vignette can be cut and fitted to the negative with an exact knowledge of how much of the figure will be included, and the depth and value of shadows occurring near its edge.

COLLODIO-CHLORIDE PROCESS.

It is curious to note that in books published some ten years ago this process is referred to as almost obsolete, whilst at the present time it is most extensively patronised. It certainly has many things to recommend it. For example, the paper may be blotted off on coming from the washing tank—a very dangerous proceeding when dealing with gelatino-chloride. Further, the paper may be dried in a gentle heat without danger, if care is taken that it does not become bone dry and crack. This cracking was at one time a serious drawback to the process, but if the paper is kept at ordinary temperature and under pressure there should be no difficulty of this kind. The paper consists of a coating of emulsion made by forming silver chloride in collodion. The earliest collodio-chloride process seems to be that introduced by Simpson in 1864, the following being the formula:

SIMPSON'S EARLY FORMULA.

(a) Silver nitrate, $\frac{3}{4}$ oz. ; distilled water, $\frac{3}{4}$ oz. ; warm gently till dissolved, and then add 5 oz. of alcohol; (b) calcium chloride, 160 grains; absolute alcohol, 5 oz. ; (c) citric acid, 160 grains; absolute alcohol, 5 oz. Take 40 oz. of plain collodion of medium density, and add to it solution (a), a little at a time, with considerable shaking. This may all be done in full light, but the remainder is preferably carried out in a yellow light. Ordinary gaslight may be used, and is not strong enough to cause serious damage, unless the paper is to be used for development. Next add solutions (b) and (c) in the manner described for (a). If the emulsion is to be used for coating opals

or glass, it may be done in the same way as varnishing a negative; but if to be applied to paper, the paper may be folded over a sheet of glass, and a pool of emulsion poured in the centre of the paper and rolled out to the edges rapidly with a glass rod. Another method is to turn up the edges of the paper to form a wall round it. The paper is then placed on a sheet of glass and coated, as in varnishing a negative.

ANOTHER GOOD FORMULA

is the following:—Silver nitrate, 28 grammes; alcohol, 100 c.c.; collodion, 500 c.c.; strontium chloride, 4 grammes; lithium chloride, 2 grammes; citric acid, 8 grammes; ether, 100 cc.; glycerine, 12 c.c. It is claimed that the use of strontium and lithium chlorides affects the colour of the image, but this is doubtful.

METHOD OF MIXING EMULSIONS.

A very ingenious method of mixing emulsions has been suggested. Two wide-mouthed bottles are placed end on, and fitted together with a rubber cork having two holes into which two glass tubes of $\frac{1}{8}$ in. centre bore are tightly fitted. These are so placed that each tube reaches almost to the bottom of one flask and just through the cork into the other vessel, thus allowing the air to pass through one tube as it is displaced by the solution passing through the other (see Fig 272). To use the arrangement, the two solutions to be mixed are placed in the separate jars or bottles, and the cork fitted tightly to one. This is then turned over and inserted in the other jar, and when firm is shaken violently until the solution has all run through, when, if desired, it may be turned over again and the operation repeated. Such a contrivance will present no difficulties to those used to rigging up apparatus for chemical experiments, but the novice is advised to see that every part fits very true, or the results may be disastrous.

PREPARING THE SOLUTION.

A large number of formulæ have been published for this process, but those given

will doubtless prove sufficient for the experimenter. Strictly speaking, the process ought to be called "citro-chloride," the real collodio-chloride process being without citric acid in its composition. For this, take 40 grains of calcium chloride and dissolve it in 1 oz. of alcohol, using sufficient heat only to effect solution. Ten grains of pyroxyline are put into a flask, and to it is added first the solution just

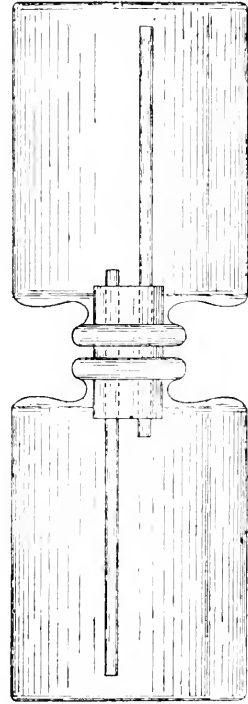

Fig. 272.—APPARATUS FOR MIXING EMULSION.

made and then 1 oz. of ether. This will now dissolve the gun-cotton to form collodion, which will be thoroughly impregnated with chloride. Next make up 100 grains of silver nitrate into a saturated solution with distilled water, using about 1 dram for the purpose, and boiling it in a test tube. Silver nitrate is soluble 1 part in 0.5 part boiling water, so that there should be no difficulty in doing this. When dissolved, mix with 2 oz. of alcohol and pour it over the 20 grains of gun-cotton which have previously been placed in a suitable vessel, and then add 2 oz. of

ether in small quantities till dissolved. The chloride and the silver solutions are

may be at once applied to the plates or paper, and does not require washing.

THE FERRO-PRUSSATE PROCESS.

The method of making and using ferro-prussiate paper (for obtaining blue prints) is described below. Prepare two solutions:—(a) Citrate of iron and ammonia 1 oz., water 4 oz.; (b) Potassium ferricyanide 1 oz., water 4 oz. Coat any tolerably pure paper of fine texture with solution (a), using for the purpose either a broad flat brush or a tuft of wool, the paper being pinned on a clean board. The wool may be fixed in the end of a piece of glass tubing and held so by passing round the wool a wire and bringing the two ends

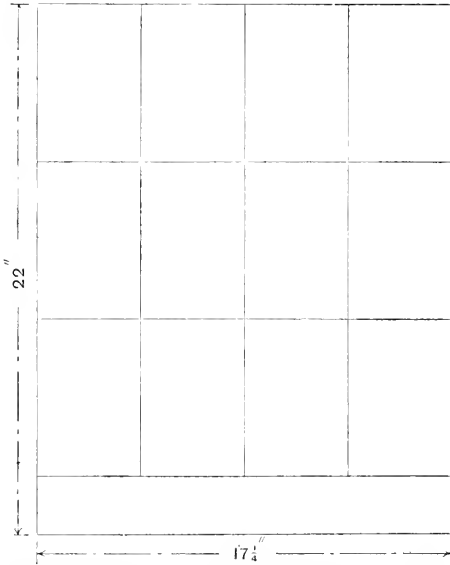

Fig. 273.—METHOD OF CUTTING PAPER FOR TWELVE CABINETS.

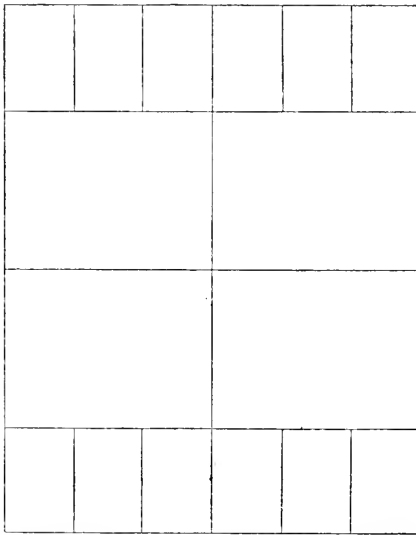

Fig. 274.—METHOD OF CUTTING PAPER FOR WHOLE-PLATES.

now mixed by pouring the chloride into the silver, which ensures the silver nitrate being always in excess. This emulsion

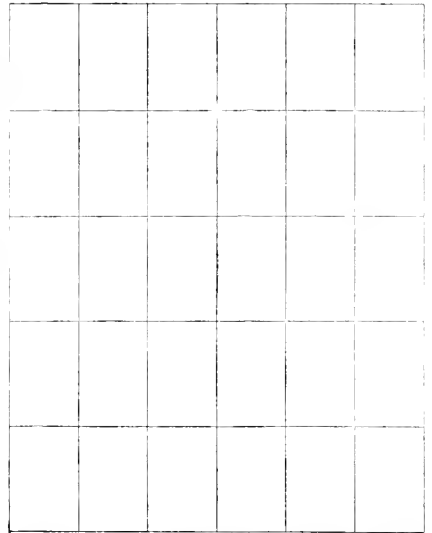

Fig. 275.—METHOD OF CUTTING PAPER FOR CARTES.

out through the opposite end of the tube. The brush should be drawn from side to side, and there should be a slight overlapping at the edges. Keep the coating as even as possible, although considerable unevenness seems to have no bad effect. The paper prints very slowly. The details should be brought out fully, and the dark parts should have a bronzed appearance. When a fairly dark brown image appears, (b) solution is applied by flowing it over the print. The result will be a picture in

Prussian blue. The print is then passed through a weak solution of citric acid, washed for a few minutes in water, and hung up to dry in gentle heat. This is the cheapest of photographic printing processes, costing very little beyond the plain paper, but is, of course, very unsuitable for general work. The ferro-prussiate process is chiefly used for copying plans and drawings or for moonlight scenes. In making up the solutions before dissolving the ferricyanide it should be rinsed in warm water to get rid of any yellowish powder adhering to the crystals, which after rinsing should be of a bright ruby colour. After dissolving the ferricyanide, take a small portion of the solution, dilute it to say one-tenth of its strength, and to this diluted solution add a small quantity of a solution of ferric salt, such as ferric chloride. If a dense dark blue precipitate forms in the ferricyanide solution, the presence of ferrocyanide (yellow prussiate) of potassium is indicated, or it may be that the ferric chloride is partly in the ferrous state. If the precipitate is a slight one, it may be disregarded, as it is almost impossible to exclude the precipitate altogether; a light blue colour would indicate that the solution is in its proper condition. To ensure the ferric condition of the iron it is advisable to add a little oxalic acid to the ferric chloride (in the proportion of 1 to 2) before making the test. If the water used is hard, a little citric acid should be added to the potassium solution. Having ascertained the condition of the potassium ferricyanide, dilute a small quantity of ammonium ferri-citrate solution, and test it with a few drops of the (b) solution. If a blue precipitate appears, the iron is in an improper condition, and should be rejected for another sample. The green ferri-ammonium citrate, if obtainable, is best. The solutions should preferably be prepared immediately before use. The paper may either be brushed over with or soaked in the solutions: the latter method yields the more vigorous prints.

CYANOTYPES.

The disadvantage of the last-named process is that it gives white lines on a blue

ground only. It is more convenient to have a white ground and dark lines. For this purpose, the paper may be coated with a solution made up as follows: 50 per cent. solution of ferric ammonium citrate,

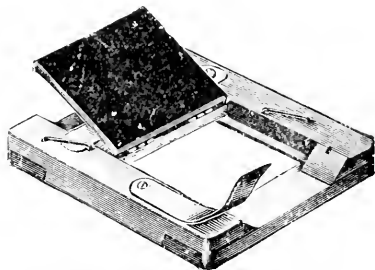

Fig. 276. — ORDINARY PRINTING FRAME.

5 parts; 50 per cent. solution of ferric chloride, 5 parts; 20 per cent. solution of gun arabic, 30 parts. Pin the paper down on a board and brush over the above solution. The board should be tilted slightly, and the brush worked from left to right, slightly overlapping at each stroke in the same way as a wash is put on in water-colour painting. The paper is fairly sensitive, and requires only a short exposure. When printed it is developed with a 10 per cent. solution of yellow prussiate of potash. As soon as all the details are out, the print is fixed in a 10 per cent. solution of hydrochloric acid. A moment's immersion between development and fixing will suffice. Other iron printing processes will be found in the section on Processes of Historical Interest.

CUTTING THE PRINTING PAPER.

It is customary to purchase all papers except albumen in cut sizes, so that instructions for cutting albumen paper will be required. It must be borne in mind that as a full sheet of gelatine-chloride paper is $1\frac{1}{2}$ in. longer and $\frac{1}{2}$ in. narrower, it cannot be cut up in the same way. The first consideration in cutting up the paper, which should be done with an eye to economy of time and material, is the stretching peculiarities of the sheet. If a print is cut one way of the paper it stretches in breadth, but if cut the opposite way it stretches in length. The point

to bear in mind is that the paper stretches most the width of the sheet. Some makes now on the market stretch in length. This is a point the worker should ascertain. It is usual, therefore, to cut the paper so that it comes the same way, as an increase in breadth is less objectionable than an increase in length. In landscape and most record work this is of little importance, but in scientific work accuracy is necessary. In such cases it is best to leave the prints unmounted, or at least to mount them only when dry. It is in portraiture that the effect of stretching is most striking, and for such work the paper must be cut as directed. As a rule, a person will have less objection to looking broader in the face than to looking narrower, except,

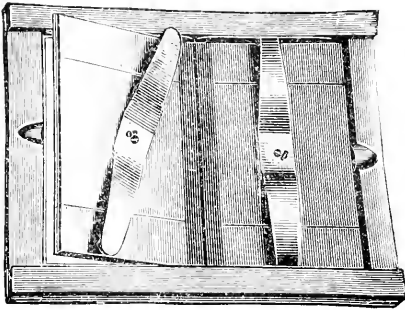

Fig. 277.—NEW PATTERN PRINTING FRAME.

perhaps, when the face is already too broad, then the paper may be cut the reverse way, so as to make the face look narrower. A diagram is given in Fig. 273 for cutting the paper for twelve cabinets, suitable for lengthening effects. Fig. 274 shows the method of cutting the sheet for whole plates, and Fig. 275 for thirty cartes.

FRAMES USED IN PRINTING.

The different patterns of frames used for holding the negative during printing may now be described. The commonest kind consists of a wooden frame with hinged back and metal springs revolving into wire loops, as shown in Fig. 276. Such frames cost 5s. per dozen quarter-plate, or 9s. 6d. per dozen half-plate. These are made of teak, but can be obtained in other woods. A very good frame is that

shown in Fig. 277. It has no projecting parts, and therefore lies flat on the bench, which is sometimes a convenience in vignetting. It has the further advantage of being smaller than other frames,

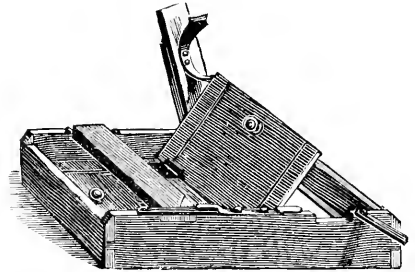

Fig. 278.—PRINTING FRAME FOR LARGE NEGATIVES.

and therefore takes up less room. A quarter-plate size measures $5\frac{1}{4}$ in. by $4\frac{1}{4}$ in. by $\frac{13}{16}$ in. These cost 5s. 6d. per dozen quarter-plate and 9s. 6d. per dozen half-plate. The printing frame shown in Fig. 278 is an excellent one for negatives of large size. It is very strong and durable, and is usually provided with a plate-glass front, so that the negative is well protected against breakage.

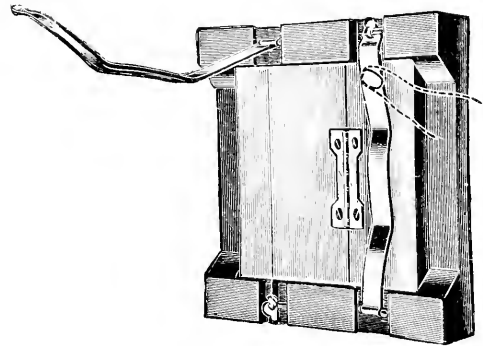

Fig. 279.—SPECIAL PRINTING FRAME.

DESIGNS FOR FRAME BACKS.

There are a large number of fancy methods for securing the frame back, of which only a few need be mentioned. Figs. 279 and 280 are handy contrivances. In the former it is merely necessary, when closing the frame, to press the hinged spring into position, when it is fastened automatically by a catch. The second

has been introduced with the aim of avoiding moving the print during its examination. In may here be mentioned that the printer should always hold the frame

examined at once: Fig. 281 has the back hinged to the frame, another excellent method of preventing movement.

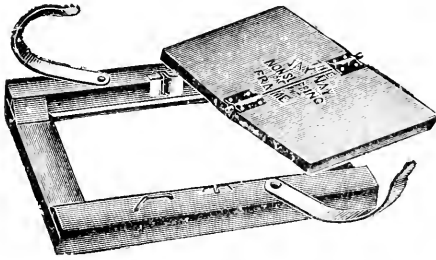

Fig. 280.—"JAYNAY" NON-SLIPPING PRINTING FRAME.

close to the body, negative side inwards, and stand with the back to the sun. Carefully fold back first the hinged flap, next the pad, and finally the print. If all three are pulled tightly back together the leverage occasioned will be sufficient to drag the print out of place, so that it will not register properly next time in printing, but will give a blurred image. The two fingers of the left hand should be

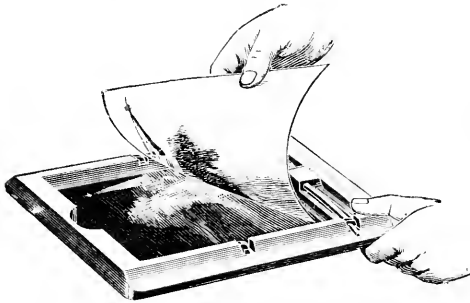

Fig. 281.—FULL-VIEW FRAME, OPEN.

kept pressed the whole time on the lower half of the frame. Figs. 281 and 282 show a frame open and closed which enables one to watch the progress of printing over nearly the whole of the picture, the special points claimed for it being full view of subject, no slipping of print, no loose springs, perfect rigidity of back, no uneven pressure, easy manipulation, and economy of space. Fig. 283 shows a non-slipping frame with a central spring, allowing both sides of the print to be

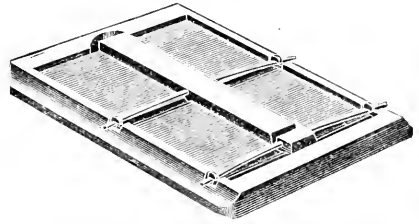

Fig. 282.—FULL-VIEW FRAME, CLOSED.

THE MARRIOTT FRAME

is specially designed for printing post-cards. Its chief feature consists of a large opaque front, with a small opening (the size being adjustable with carriers), as shown in Fig. 285, recessed on the inside to take the negative. This enables the postcard to be moved about in any direction, so that a portion only need be

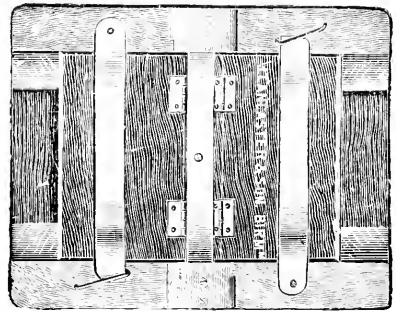

Fig. 283.—FRAME WITH CENTRAL SPRING.

printed, and the remainder masked from extraneous light. The back is not hinged in the middle, but more to one side, so that a fairly full view of the picture can be obtained on opening it for examination.

PRINT INDICATORS.

While dealing with printing frames, mention must be made of the print indicator. This is a little apparatus like a clock dial, numbered from one to twelve, and provided with a pointer which grips into slots (see Fig. 286), and is set opposite to the number of prints made: by setting the pointer to a fresh number on the

completion of each print, waste from over-printing is avoided. These cost 1s. per dozen.

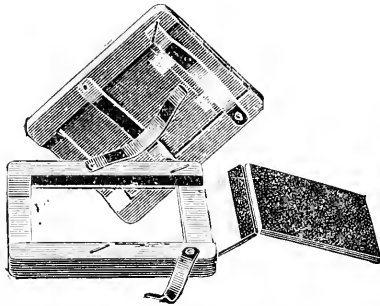

Fig. 284.—FRAME WITH HINGED-ON BACK.

PRINTING SHEDS.

The photographer who has to complete work in a given time must be independent, as far as possible, of the weather. Of the light he can not be altogether independent, although something may be done in the development of print-out papers, as will be seen when that part of the subject is dealt with. He must therefore be provided with a printing shed. This consists

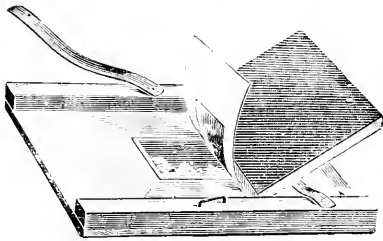

Fig. 285.—“MARRIOTT” POST-CARD PRINTING FRAME

of a long bench with a glass roof (see Fig. 287). The glass projects some 2 ft. beyond the bench as an extra protection, this also shielding the operator. For printing on a small scale, the print may, of course, be exposed in an ordinary greenhouse or cucumber-frame. The frame must be kept dry any way, and it might be mentioned that the practice of turning frames over when a shower comes on is bad, as a negative is more likely to get wet from the back than the front. Frames should always have a

sheet of clean glass in front to protect the negative and any working up on the glass side. Rubber backing is advisable always.

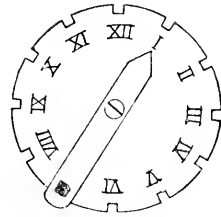

Fig. 286.—PRINT INDICATOR.

PRINTING ON A LARGE SCALE.

The routine of printing in a large establishment is as follows. The albumenised paper is first floated, and then hung up to dry in a separate room, the floor of which is kept a little damp, every precaution being taken to avoid dust. Proof negatives are put out first of all. Full instructions are issued to the printer as to whether the picture is to be vignettted, masked, or printed plain. It is usual, after the frames have been fitted up, for this work to be repeated by lads whilst the printer attends to the frames which are actually being exposed. The expert printer can attend to a great number of frames by working systematically. He arranges the negatives into groups—thin, medium and dense—and can frequently tell to the moment when the print is done without examination. The advantage of this expertness lies in the fact that there is no fear of degradation of the lights liable to occur from examination of the print in the light of day. Where negatives require dodging, however, frequent examination must be made, and the careful operator will have at hand a box full of pieces of cardboard cut into shapes, together with a few uncut sheets and a pair of scissors. If he finds the printing proceeding too rapidly in any part, he covers it with a piece of card, thus allowing the denser parts to go on printing and catch up in tone. It is perhaps in this direction, more than in any other, that excellence in printing is to be found. When the prints are removed from

the frames, they are placed in boxes under pressure until the afternoon, when the day's toning and fixing is done.

CONCLUDING REMARKS.

Although it is certainly better to have a covered-over shed for the purpose, many printers work in the open air. When this is the case certain special precautions are necessary. A large amount of dust and

grit is sure to get on the glass of the frames, and this must be brushed off at intervals. A strict watch must be kept for rain, and the frames carried indoors directly it is noticed, and, if necessary, carefully wiped dry. Do not adopt the practice of turning over the frames. A negative is more likely to be injured by rain from the back than the front. Particular attention is also required in frosty weather.

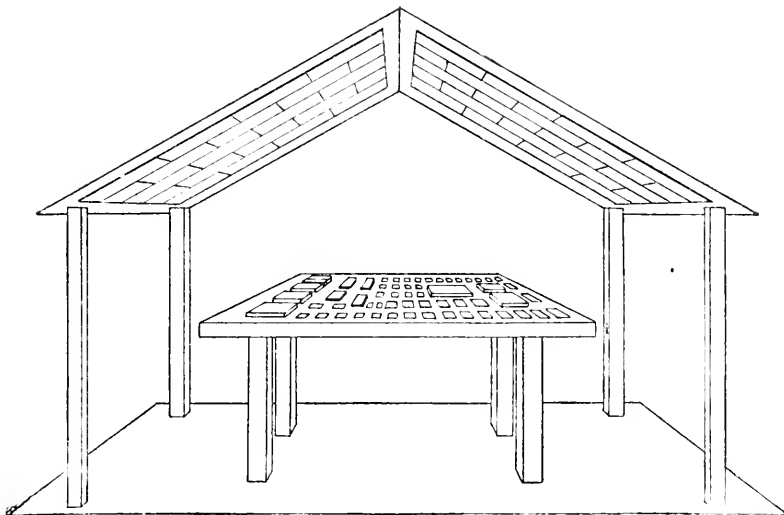

Fig. 287.—PRINTING SHED.

DEVELOPMENT PROCESSES OF PRINTING.

THE CARBON PROCESS.

ONE of the processes worked extensively by high-class photographers is the carbon process, which, when carried out by skilful hands, affords the most beautiful effects obtainable by photography. The process is by no means a new one. The action of light upon chromic salts was investigated by Mungo Ponton in 1839; but it was not until 1864 that Swan brought forward the carbon process by transfer in a form very similar to that now practised.

NOT A DIFFICULT PROCESS.

The difficulty in obtaining the necessary materials, and the fact that many of these had to be made by the worker, combined with the uncertainty of result and the difficulty of properly gauging exposure, has until recent years led to the exclusion of amateur or small trade workers from the ranks of carbon printers. Even now many imagine that the carbon process is an extremely difficult one, whereas, if ready-made materials, now so easily obtained, are used, it is as simple as any other, and offers unlimited opportunities of securing artistic and effective results.

PERMANENCY OF CARBON PRINTS.

Of the permanency of carbon prints generally there can be no doubt. The image consists of gelatine in an insoluble form, and usually carbon, both of which, under ordinary conditions, are very stable products and unlikely to change. The permanency, however, depends entirely upon the pigment employed, as is the case with water-colour painting. Colours which,

like the lakes, fade rapidly must of course be avoided if the result is to be permanent. On the whole, the carbon process is not unlike water-colour painting, for it has the same choice of colour and gradation; but it has just this difference—that whereas the water-colour artist adds continual washes of colour until he obtains the depth of tint required, the carbon printer washes away his colour continually, making the picture lighter until the proper depth is obtained.

PRINCIPLE OF THE CARBON PROCESS.

The carbon process is based upon the hardening action of light on gelatine which has been immersed in potassium bichromate. To make this clear, take two pieces of ordinary gelatine, such as are readily soluble in slightly warmed water, or two glass plates, coated with a 5 per cent. solution of Nelson's No. 1 gelatine in the same manner as a negative is varnished may be used, and immerse one of them in a 1 per cent. solution of potassium bichromate and allow it to dry. Expose both to bright daylight for an hour or so. Now if the two are placed in hot water, it will be found that the plain gelatine readily dissolves, whilst that which was immersed in potassium bichromate has become insoluble. Let another gelatinised plate be soaked in bichromate solution as before and exposed to light through a glass, but in this case cover a portion of it with a cross, as shown in Fig. 258. Immerse this again in hot water, and the portion shielded from the light by the cross will remain soluble and may easily be dissolved away. On

placing this plate in a coloured solution such as an aniline dye, the dye will be taken up most in the thicker portion, the result being, if a blue dye is used, a white cross on a blue background.

CHEMICAL ASPECTS.

Of the chemistry involved in the process little need be said. Chemists use potassium bichromate to change ferrous salts to the ferric state, and by employing a solution of known strength and ascertaining when the action is complete, the amount of iron in the ferrous compound may be estimated quantitatively: thus,

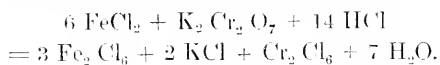

In other words, the oxygen and potassium are readily parted with, and a pure chromium

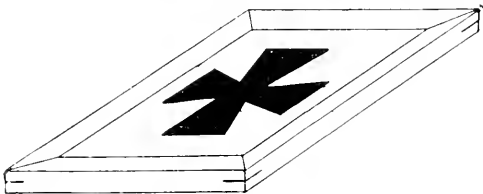
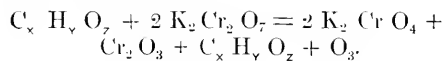

Fig. 288.—EXPERIMENT WITH BICHROMATED GELATINE.

compound is formed. A somewhat similar action occurs when the bichromate is exposed, in contact with organic matter, to light.

Organic matter + potassium bichromate = potassium chromate + chromium oxide + organic matter.



There are two chromates of potassium, the neutral yellow chromate $\text{K}_2 \text{ Cr O}_4$ and the acid orange chromate $\text{K}_2 \text{ Cr}_2 \text{ O}_7$. It is the latter which is chiefly of importance in this connection, as it is the least stable; its action is to oxidise any organic matter with which it comes in contact, and to render it insoluble. It is called bi-chromate because it contains two molecules of acid to one of base, and it is soluble to the extent of 10 per cent. at a normal tem-

perature, namely, 60° . It is decomposed by light, yielding up about one-fifth of its oxygen to any organic body with which it comes in contact, forming also an oxide of chromium, as will be seen by looking at the equation given above. The organic body thus oxidised loses its solubility, but regains it slightly if rendered strongly alkaline.

SINGLE TRANSFER.

Perhaps it will be best to consider first the production of the carbon print with ready-made materials and by the simplest process, namely, the single transfer. The negative should be one showing as near as possible perfect gradation together with bright contrast—a negative which would print somewhat hard on ordinary silver paper. It should not be a dense one; the shadows of the negative should be represented by almost clear glass. The carbon process, however, may in skilful hands



Fig. 289.—BRUSH FOR SAFE-EDGING NEGATIVE.

be adapted to secure excellent results from a variety of negatives, by alterations in the sensitising bath and by modification of exposure and development; but for early attempts a good negative should be chosen.

MAKING THE SAFE-EDGE.

The first operation is that of applying the safe-edge. This is an opaque margin about $\frac{1}{4}$ in. all round the negative, made by means of a brush as shown in Fig. 289. Dip the brush in a vessel of Bates' Black (obtainable at any photographic dealer's at 6d. per bottle) and, placing the end of the brush A against the edge, draw it down the side of the negative. This will give a clean border of equal width, if great care is taken. This solution is extremely opaque, and dries readily. "Photopake" also may be used for the purpose. Some workers prefer to attach a strip of lantern-slide binding A cut in

two, so as to make a width of about $\frac{1}{4}$ in. (see A, Fig. 290). If the picture is to be vignettted, the safe-edge is unnecessary, as the vignette itself fulfils the purpose.

CARBON TISSUE.

The next requirement will be some sensitive carbon tissue. Tissue is the technical name given to paper coated with gelatine and pigment. It may be purchased either sensitive or insensitive, but the beginner is advised to obtain the sensitive variety. A quarter-plate packet of assorted tissue will do to experiment with; the tissue deteriorates by

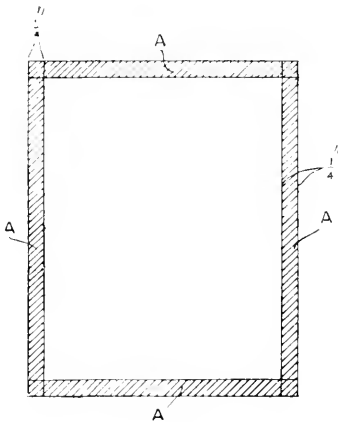

Fig. 290.—SAFE EDGE OF LANTERN-SLIDE BINDING.

keeping, and will probably not be fit to use after a week. Much will depend, however, upon the manner of keeping it. The deterioration arises from its being oxidised and becoming insoluble without exposure to light; therefore it should be kept away from the air. A copying press will answer the purpose, or a pressure-box may be extemporised out of a cardboard box and a few old negatives. Convenient cases for storing carbon tissue, with a rear compartment for calcium chloride and a spring to keep the prints flat, are now obtainable (see Fig. 291). A packet of single transfer supports must also be obtained: these are papers of a variety of texture, having the surface coated with a layer of insoluble gelatine.

SINGLE TRANSFER OUTFITS.

The best plan for a beginner will be to procure a single-transfer outfit. A speciality is made of these sample packets. Each packet contains one dozen assorted tissues, 3 pieces of temporary support, 3 pieces of single transfer, 3 pieces of toned etching paper, 6 pieces of final support, and pamphlet giving all instructions. The Autotype Co., New Oxford Street, London, W.C., supply "trial sets" of carbon printing materials, comprising sensitive tissue, single transfer paper, actinometer, squeegee, safe-edge

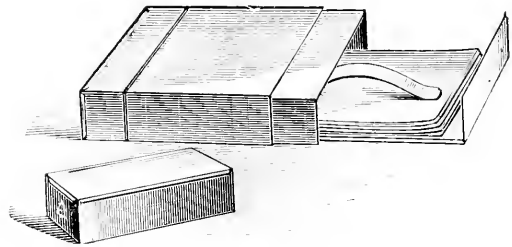

Fig. 291.—CASE FOR CARBON PAPER.

masks, powdered alum, and full instructions.

PRINTING.

The negative, with its back carefully cleaned, is now laid, film up, in the printing frame, and the packet of tissue opened in subdued light. The tissue is not so sensitive as to need to be kept in the dark; but being more sensitive than ordinary silver paper, less light should be used. The tissue is almost black on one side and yellow on the other; the black is the sensitive side, and should, of course, be in contact with the film. If an assorted packet of tissue is purchased—that is, one containing various colours, such as engraving black, standard brown, sepia, red chalk, and blue—it will be found that the surface in each case differs only slightly; the blue and the black will scarcely be distinguishable, whilst the red chalk will appear a brown. The makers, to prevent mistakes, usually stamp the back with the

name of the colour. From this it will be seen that pictures by the carbon process may be of any colour. The colours mentioned are generally in stock, but manufacturers are always willing to make up tissue to match any colour provided a sufficient quantity is ordered. The colours named, however, give sufficient choice for all purposes. A selection must be made to suit the character of the subject. Engraving black or standard brown are suitable for general work, the warm colours for fancy pictures, sunset effects, etc., and blue for moonlight scenes.

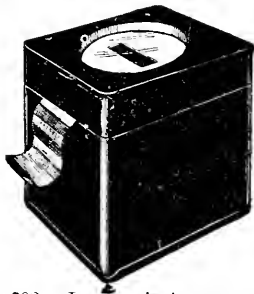

Fig. 292.—JOHNSON'S ACTINOMETER.

TESTING EXPOSURE.

It will be obvious that an image printing on such tissue cannot possibly show, therefore a comparative test must be undertaken to ascertain when the exposure is complete. A simple plan for finding the correct time is to expose a strip of P.O.P. beneath a negative of similar density, and when this is printed to a depth sufficient for a rough proof, that is a little lighter than one would wish the finished print to be, not making any allowance for loss in fixing, etc., the carbon print may be taken to be sufficiently exposed. It is best to adhere to this same test negative, merely varying the depth of the print for negatives of different density; but for a first attempt, the nearer the density of the real negative and the test negative the better.

ACTINOMETERS.

For regular work, an actinometer constructed on the principle described in the section on "Exposure" is used. Two well-known forms in common use are Johnson's

and Wynne's. The former is shown by Fig. 292, and consists of a metal box with lid containing a wooden block hollowed out in the centre to take a coil of P.O.P. or sensitive albumen paper. This passes over the top of the block under wire loops beneath the opening, coming out at the slot at the side. The circle is painted a medium brown, and it is to this shade which the paper has to darken two or more times, according to the density of the negative. The latter consists,

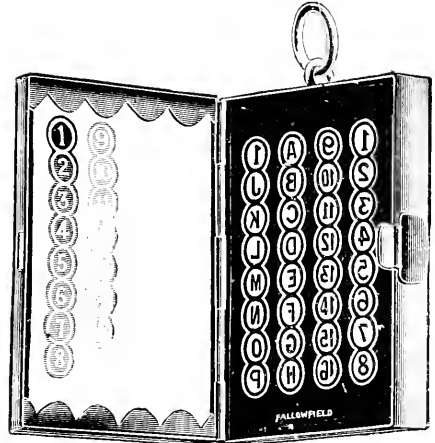

Fig. 293.—WYNNE'S PRINT METER.

as shown in Fig. 293, of a metal frame fronted by a sheet of opal, behind which is a plate perforated with holes of such diameters that each one admits one-tenth the amount of light less than the one above. On the left of the instrument are the letters A to P. This arrangement, by means of a series of densities, produces different light intensities of the same relative value, graduated by reductions of one-tenth.

USING THE ACTINOMETER.

To use the actinometer, place a strip of ordinary P.O.P. (Fig. 293) beneath the projections, and fasten the box by means of the catch. The paper will be held tightly in contact by means of a felt pad covered with a strip of talc. Place it in the light, opal side uppermost. In a few moments open the frame, and it will be found that the figure 1 will have printed

on the strip of paper. Close it again for a few moments and re-open, and some other figure will be found to have printed. The length of exposure, or the amount of light's action, may be gauged from the number on the paper. A negative of average density requires about 12, which means that this number should be just discernible; thinner negatives less, denser negatives more. This must be exposed side by side with a negative, so that it may receive the same amount of light, and when the number is reached the carbon print will be finished. The Watkins' Print Meter (Fig. 294) is another very convenient device.

A SIMPLE ACTINOMETER

may be made by pasting on a sheet of glass strips of tissue paper, one over the other.



Fig. 294.—WATKINS' PRINT METER.

The bottom strip is the longest, each succeeding strip being a little shorter than the one beneath, so that on the bottom edge there will be only one thickness, on the edge of the next strip two thicknesses, and so on. A similar effect may be produced by giving graduated exposures to a process or ordinary plate, and developing a deep image. This may be done as described in the section on Exposure. Such actinometers resemble in principle that shown by Fig. 295, which is known as the "Akuret" Print Meter.

DEVELOPING THE PRINT.

The carbon print should be developed directly it has been sufficiently exposed. Lay some pieces of blotting-paper on the table, and cover with a few old negatives. The sheet of single transfer face upwards, together with the printing tissue, face downwards, are immersed in cold water (in

warm weather a piece of ice may be put in the water to keep down the temperature). See that the tissue goes right under the water, and that there are no air-bubbles adhering to it. On first entering the water the tissue will show a tendency to curl up, but should not be allowed to do so. Curling can be prevented by stroking the back of the tissue with a squeegee. Allow the tissue to remain until it begins to straighten itself out, then bring the two surfaces together underneath the water and withdraw slowly.

THE STROKING OPERATION.

Next lay the papers tissue upwards on a sheet of glass, and stroke into close contact with the squeegee, as shown in Fig. 296. The squeegee (Fig. 297) consists of a strip of wood with a groove cut down one

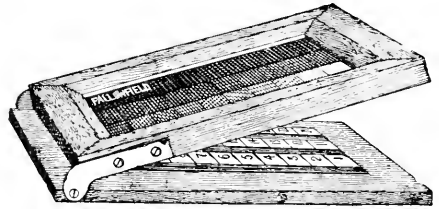

Fig. 295.—THE "AKURET" PRINT METER.

edge, into which is slipped a strip of rubber; screws are put through the handle to tighten up the groove and hold the rubber firmly. A wedge-shaped piece of wood forms a crude substitute. The object of the stroking operation is to bring the two pieces of paper into absolute contact and force out all moisture and air between the films of gelatine. The stroking, therefore, must be done firmly and in one sweep: it is preferable to give a few strokes in one direction, then to lift the papers and stroke in the opposite direction. Be careful not to disturb the surface of the tissue support.

PRESSING AND MOUNTING.

Now place the papers between the sheets of blotting-paper, and keep them pressed down with a pile of old negatives. The tissue thus mounted should remain under pressure for ten minutes. When sufficiently pressed, half fill a small hand-basin a few sizes larger than the print with

water about as warm as the hand can comfortably bear it, and into this plunge the mounted tissue. In practice, several tissues may be immersed for mounting, together with their supports, at the same time, the same remark applying to development: but the beginner is advised to treat them one at a time. In a few moments the gelatine will ooze out between the two papers. As soon as this takes place, lift one corner, and, keeping it underneath the surface, pull gently off. Take the transfer support by one corner, and shake it gently in the water, when the

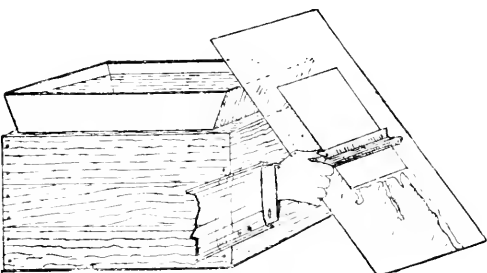

Fig. 296.—THE STROKING OPERATION.

colouring matter and the gelatine will begin to be diffused in the water.

METHOD OF DEVELOPMENT.

A thin board is floated on the surface of the solution, and on this the print is laid face upwards, the warm water being laved over it with the right hand, or a wooden spoon may be used by those with sensitive skins, until the print is of proper depth. At first it appears dark and smeary, but as development proceeds it clears up and the contrasts brighten. Do not be alarmed if the picture appears to be running together and fogging, as usually this will all wash off; but if the tendency should be very pronounced, under-exposure is indicated.

FINISHING OFF.

Continue development until the print shows no sign of alteration, when it may

be at once transferred to a saturated solution of alum or a solution of chrome alum; but preferably it should be given a few moments' immersion in a dish of cold water. After about ten minutes' washing, the print is hung up, or laid out to dry, face upwards, on blotting paper.

A DISADVANTAGE OF SINGLE TRANSFER.

The foregoing is a brief outline of the single transfer process—sufficient to enable the novice to commence work. It will be seen that the process has the disadvantage of reversing the picture—that is to say, the right will come out on the left and the left on the right. To overcome this difficulty, another process called

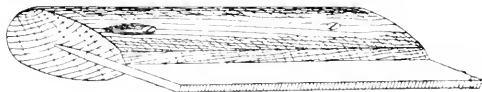

Fig. 297.—FLAT RUBBER SQUEEGEE.

double transfer has been introduced, necessitating a second transfer. This process is the one almost entirely used by professional photographers, and will be fully dealt with later. It is now proposed to deal with the single transfer process in detail.

PREPARATION OF THE TISSUE.

This is an operation which, like dry-plate making, cannot be successfully performed with any degree of certainty except under the conditions of a large factory. Experimental work, however, is valuable, and no effort should be spared in acquiring knowledge of every branch of the work. The tissue is the same for both single and double transfer. The paper to receive the pigmented gelatine may be of a coarse quality. Ordinary cartridge drawing paper answers extremely well, as the paper is used merely as a temporary support for the image.

THE GELATINE.

The gelatine is the most important element in the process, and it is absolutely

necessary to obtain a good sample. It must be thoroughly pure, very soluble, and at the same time be capable of setting quite firm. The gelatines that are artificially hardened with alum are altogether useless. The suitability of the gelatine may be tested by ascertaining its melting point, as described in the section on Printing-out Processes and Papers, choosing for work 4 parts of soft gelatine and 1 part of hard gelatine. When the weather is exceedingly warm, the proportion of hard gelatine must be increased, and *vice versa*. The following formula is recommended: Gelatine, 10 oz. ; sugar, $2\frac{1}{2}$ oz. ; potassium bichromate, $\frac{1}{2}$ oz. ; water, 40 oz. ; colouring matter, $\frac{1}{4}$ oz. to $\frac{1}{2}$ oz. In warm climates it is advisable to add glycerine in place of some of the water to the solution. Instead of the potassium bichromate it is now usual to employ the

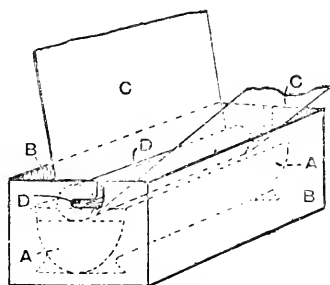

Fig. 298.—COATING TISSUE ON SMALL SCALE.

double salt ammonium potassium chromate by dissolving the potassium bichromate in 5 oz. of water and adding liquid ammonia in slight excess, which may be ascertained by the odour given off.

COLOURING PIGMENT.

Any finely ground colour, or even metal-dust, may be used as colouring matter; there is, therefore, an immense variety to choose from. For experimental work a tube of moist water-colour will be most satisfactory. Whichever kind is used, the pigment must be in an extremely fine state of division. If the common commercial colours are employed, they will require considerably more grinding.

COATING THE PAPER.

Tissue is of two varieties, the one having a much thicker layer of gelatine than the other. The thicker kind is used for making transparencies, optical-lantern slides, etc. ; it is capable of longer printing, and gives greater density on the glass. The paper is coated in the same way as described in the section on Printing-out Papers ; but, of course, as it is less sensitive to light, this may be done under different conditions of lighting.

ALTERNATIVE METHODS OF COATING.

A method which has been suggested, and which seems fairly satisfactory, consists in placing two papers back to back (see Fig. 298), so that they form a loop, similar to the manner in which a length of film is held when being developed in one piece. The backs being together, the solution cannot penetrate between them, so that only the front of each sheet becomes coated with the pigmented gelatine. A better plan, perhaps, is first of all to wet both sheets—which, if the operator stands on a pair of steps, and has the apparatus on the ground, may be from 4 ft. to 6 ft. long—and stroke firmly into close contact with a squeegee; they will then hold more tightly together, and may be easily manipulated.

SENSITISING SOLUTION.

If the potassium bichromate has been omitted, the tissue will have to be sensitised before being used. For this purpose the following bath must be made up: Potassium bichromate, 1 oz. ; water, 35 oz. ; ammonia, 20 minims. This gives practically a 3 per cent. solution, which is the strength suitable for average negatives. Modified effects, however, can be obtained; that is to say, the tissue can be made to suit either flat or hard negatives by altering the strength of the solution. A stronger solution than that given, say 4 per cent., will give softer results by rendering it more sensitive, while a weaker solution will tend to greater contrast by rendering it less sensitive. The strength of the bath may be anything

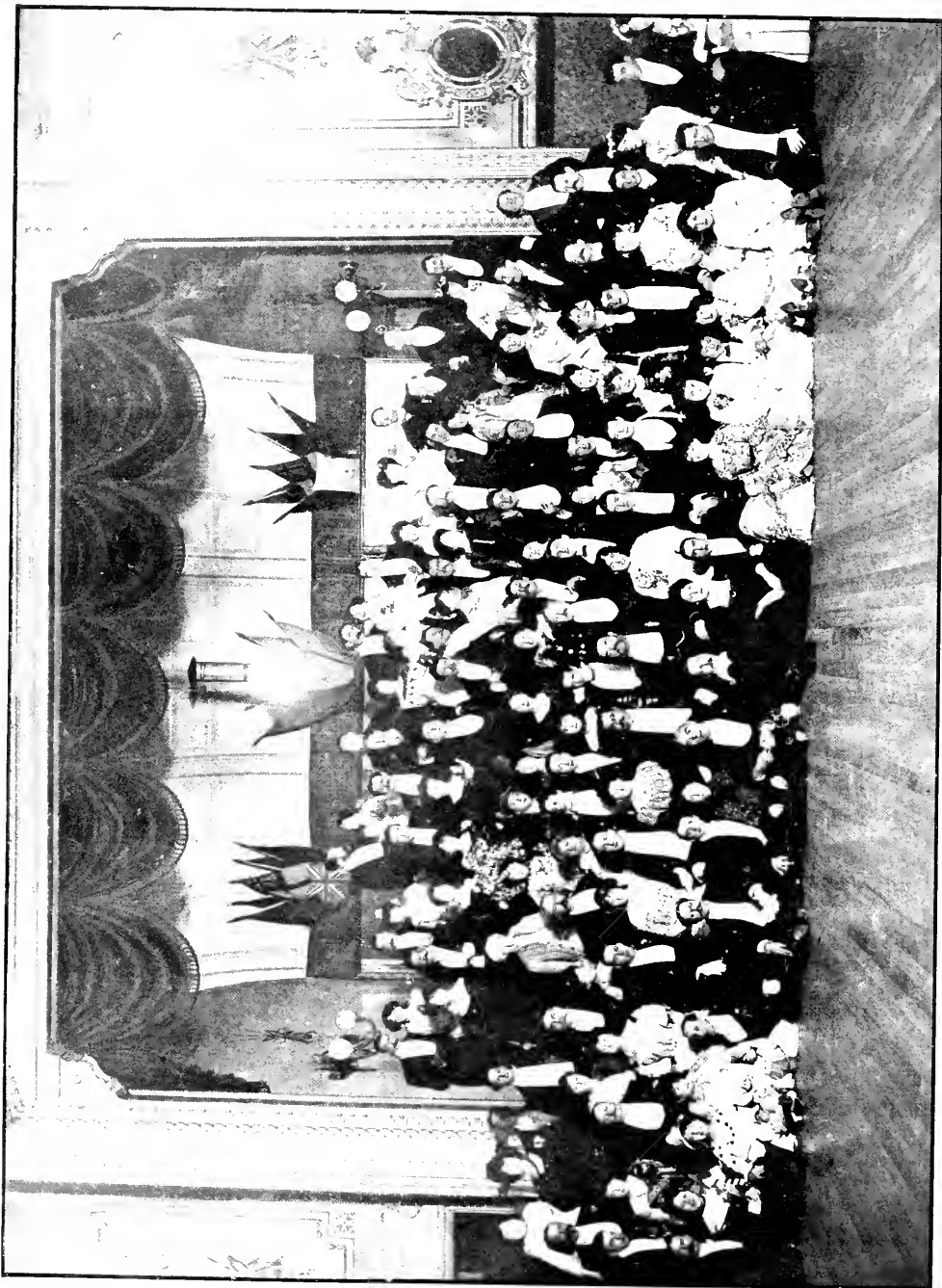

EXAMPLE OF FLASHLIGHT PHOTOGRAPHY

between 1 per cent. and 8 per cent. ; but it is seldom required weaker than 2 per cent. or stronger than 6 per cent. Tissue prepared in a strong bath does not possess such good keeping qualities, while that prepared in a weak bath takes longer to print, but keeps well. The temperature seems to have some bearing upon the strength of the bath. For example, the bath may be stronger in winter than in summer, and will produce exactly the same result.

DEFECTIVE NEGATIVES.

It must not be supposed that variation of the bath will make up for a defective negative, for one which is really hard from under-exposure—that is, one with dense high lights and clear glass shadows—will never give a good print by any method. In extreme cases of negatives suffering from over-exposure, being in consequence thin and weak, a transparency tissue sensitised in a weak bath will give the best effect. The print should be fully exposed, and development effected with very hot water containing a little ammonia. When working with hard negatives, print in a strong light in the least possible time, and develop at a low temperature.

KEEPING QUALITIES OF TISSUE.

So far as the finished result is concerned, there seems to be no difference whether the potassium bichromate is added in making the tissue or whether it is sensitised afterwards. When working on a small scale, it is not always convenient to use ready sensitised tissue, owing to the fact that it soon becomes insoluble and is thus rendered useless. Tissue becomes more sensitive by keeping ; that is, it gradually becomes spontaneously insoluble ; so that a slow tissue which has been kept, say, a week, may become an extremely rapid one. Therefore, when the tissue is likely to be kept it is best to use a moderately weak bath. This fact must also be borne in mind when exposing, otherwise the print will appear over-done. So that a negative which may require a

certain number of tints on the day tissue is prepared may need much less exposure a couple of days afterwards.

TESTING THE TISSUE.

The following experiment will prove whether the tissue is in workable condition or not. Cut a small strip of tissue for examination, and place it in a boiling-tube ; cover with water, and add one drop of ammonia. Hold this in the flame of a Bunsen burner until the water boils. Then shake the tube, and if the gelatine shows no signs of dissolving off the paper, it may be taken to be useless ; if, on the other hand, the water soon becomes discoloured and muddy, the paper is still in workable condition. Another simple test is to wet the thumb in the mouth, and rub a few times upon the face of the tissue. If the tissue sticks to the thumb, it is good ; if the tissue sticks after considerable rubbing, it is workable, but may have a tint which would degrade the whites of the print ; if, after repeated rubbing, the tissue shows no tendency to adhere, this proves complete insolubility, and the material is therefore unworkable.

CHROMIC SALTS FOR SENSITISING.

Various chromic salts may be used for sensitising, but only three have been practically employed ; they are potassium bichromate, ammonium bichromate, and the double salt ammonia potassium chromate. The advantage of using the last named salt, which is that formed by the addition of the ammonia in the formula given on p. 192, is that it forms a tissue which does not so readily become insoluble and will therefore keep better. The first addition of ammonia does not impart its characteristic odour, but as more ammonia is added, the odour will recur, and at the same time the solution will change to a lemon yellow, indicating the formation of the double salt with ammonia in excess. Before dissolving the bichromate, it should be pounded well in a mortar or suspended in hot water in a muslin bag. The addition of ammonia has a further advantage, inasmuch as it neu-

tralisés any free acid contained in the salt. If desired the bichromate solution may be made up in "stock" form, and diluted to various strengths, but this is seldom or never done, even in the largest works. In fact, constant changes in the strength of the bath are unwise, as they merely lead to useless complications.

IMMERSING THE TISSUE.

The time of immersion in the bath may vary from three to five minutes without appearing to have any effect on the result. Exceedingly short or exceedingly long immersion, however, seems to some extent to approach the effect of using weak or

dish, so as to bring away as little of the solution as possible. Ferrotypes or zinc plates are preferable to glass, as they exclude all light from the tissue.

INJURIOUS EFFECTS OF POTASSIUM BICHROMATE.

Potassium bichromate has been found to exercise an exceedingly injurious effect on the health of persons continually dabbling in it; but the worker on a small scale need have no fear about this, and all possibility of harm is removed if the operator wears rubber finger-stalls, which roll off the fingers easily. They are obtainable at any chemist's for a few pence, and may be used for various other operations, such as developing, silver sensitising, etc.; but it is advisable to keep a separate set for each purpose, as they are difficult to keep clean. Persons who are affected by the metal developer would do well to use them; the slight clumsiness that results when they are first used is soon overcome.

BICHROMATE DISEASE.

In this connection, Mr. E. W. Foxlee a few years ago gave some interesting advice. His experience was that the ill effects arising from the use of potassium bichromate were of two kinds: the slighter when the bichromate found its way into cuts in the fingers, and caused smarting, followed, if not attended to, by ulceration; the other and more serious effect, and known as bichromate disease, is first indicated by irritation of the skin on the back and between the fingers, the skin afterwards becoming dry and peeling off in scales. The disease is believed to be quite local and not infectious. As a remedy, Mr. Foxlee suggests bathing the affected parts in very weak ammonia, and following this with bread poultices. The following lotion is recommended by the same writer: Crystallised carbolic acid, 40 grs.; glycerine, $\frac{1}{2}$ oz.; alcohol, 5 oz.; or failing this a dilute solution of subacetate of lead. In any case, the disease seems to be soon overcome if further contact with the bichromate is avoided.

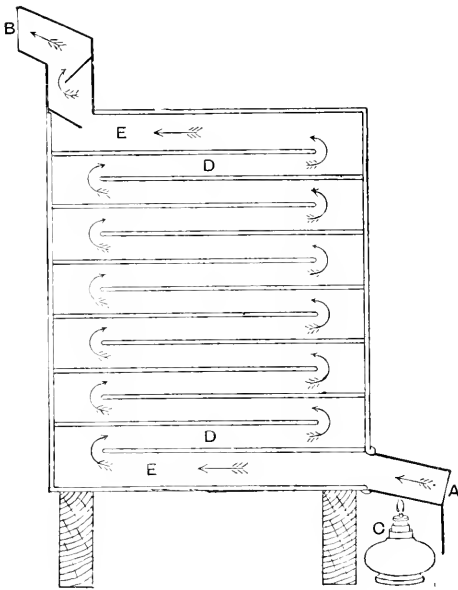

Fig. 299.—DRYING CUPBOARD.

strong baths. If the bath is sufficiently deep—and it is as well to choose one from 3 in. to 4 in. deep—about half a dozen tissues may be immersed together, but it is advisable to keep them constantly on the move. Keep the tissues in regular order in the bath, so that the first one immersed may be the first one withdrawn. Draw them slowly over the side of the

DRYING THE TISSUE.

The tissue should now be dried as quickly as possible, but care must be taken that it is not placed in the fumes from either gas or oil, as this causes spontaneous insolubility. When working on a small scale, the tissue may be sensitised overnight and placed on a shelf in a warm, well-ventilated room, or, say, on the mantelpiece; but for commercial work a drying cupboard is a necessity. Fig. 299 shows the principle of a suitable drying cupboard. It consists of an inlet A and an outlet B, and the air is caused to travel the more rapidly through it by means of a spirit-lamp placed at C; the passage of the air over the plates D is shown by the arrows E. The temperature for drying the tissue should not exceed 70° F., and should be completed in about six hours. This will indicate how much heat it is allowable to use in the drying cupboard just described. Sufficient only to warm the air to the temperature stated should be used, so as to make it flow more freely and cause the moisture to volatilise more quickly. In large workshops it is usual to have the outlet connected with an air shaft. It is preferable to lay the tissue flat rather than to hang it up, as the latter method may lead to unequal sensitiveness. When the tissue is dry it should spontaneously split off its support, and should then be placed in a pressure box, as previously described.

SINGLE TRANSFER SUPPORTS.

A method of making these may be given, although, as already stated, it is better to purchase them ready made. Take $\frac{1}{2}$ oz. of Nelson's No. 1 gelatine, and rinse and soak in 10 oz. of water; dissolve this in the water bath, and add two drops in a little water of formalin. The object of the formalin is to render the gelatine practically insoluble; chrome alum may be used for the same purpose. In certain cases the paper, gelatinised glass, wood, or whatever forms the support, may be soaked in a 1 per cent. solution of potassium bichromate, dried, and exposed to light. It is advisable, if the last method

is used, to wash the support before transfer.

DOUBLE TRANSFER FINAL SUPPORT.

Take 1 oz. of Nelson's No. 1 gelatine, and dissolve in 10 oz. of water. Coat the paper with this, and, when dry, immerse in a 2 per cent. solution of alum for five minutes. When dry the support is ready for use.

TEMPORARY SUPPORTS.

These may be either rigid or flexible. The rigid support is used when the final is to be flexible, and the flexible support when the final is to be rigid. For instance, if an ordinary paper print is required by the double transfer process, a temporary support may be either zinc, glass, or opal, the latter being decidedly the best, as the ground surface of the opal imparts a pleasing texture to the print when it peels off. On the other hand, if a carbon, ivory, or opal is to be produced, the temporary support should consist of a stout paper, which will stand repeated soaking, coated with a solution of rubber or thoroughly insoluble gelatine. These temporary flexible supports can be obtained from the manufacturers of the tissue, and may be used repeatedly.

WAXING TEMPORARY SUPPORTS.

Whichever of the temporary supports is chosen, it must first be thoroughly well covered with a waxing solution. Take 30 grs. of beeswax and 1 drachm of yellow resin, and dissolve in 5 oz. of turpentine. Shake violently to ensure a complete mixture. Then take a piece of flannel, and, pouring a little of the solution upon it, rub thoroughly over the support in every direction, standing aside while the solvent evaporates. When using a support for the first time, it is advisable to wax it twice or even three times. This absolutely ensures its being covered with a thin layer of wax, so slight, however, as to be indiscernible. Should it not be completely covered, the print will stick and refuse to leave it properly, and when

this has once occurred with a support it might almost as well be thrown away, for the tendency to stick will continue. Before the supports are used, and occasionally afterwards, they should be well cleaned with soap and water. Rigid supports may be scrubbed with a nail-brush.

DOUBLE TRANSFER PROCESS.

Printing in the double transfer process is carried out in the same way as in the single transfer, the negatives being safeguarded to avoid frilling. It has been pointed out that carbon printing gives the image reversed as regards right and left, and for certain subjects this would be a serious defect. A moment's consideration will show how this occurs. Fig. 300 shows a section of a piece of carbon tissue. The light in falling upon it renders certain



Fig. 300.—MAGNIFIED SECTION OF TISSUE.

parts insoluble, which are represented in the figure by the shaded portions. It will be seen, therefore, that the soluble portions are situated underneath, and in order to remove them it would be necessary, first of all, to remove the parts forming the picture. Therefore, either the image must be transferred or the tissue must be exposed through its supports. Unless the support were a transparent one, the latter method would, of course, be out of the question. The principle, however, is made use of in some processes, and has been practised in one form or another ever since the process was introduced.

DOUBLE TRANSFER TO ROUGH SURFACE PAPERS.

This is generally considered rather difficult to accomplish, although in theory it is quite simple. One method consists of developing upon a flexible temporary support which is prepared of specially thin paper so as to fall into the grain of the paper as far as possible. The prints must be allowed to dry on the support, and

may be afterwards transferred to any surface in the following manner: Make a 5 per cent. starch paste, and when cold, lay a good thickness of it on the face of the transfer paper, the object being to fill up the grain and make the surface more level. The print is treated in the same way, but only a thin coating is required on this. Both are then laid aside for about a quarter of an hour. Provide a large deep dish of cold water, and draw the transfer paper under the water, face up; then do the same with the print, but turning it face down. Now bring the two coated surfaces together, gently lift them out of the water, hang them on a lath with pins attached, and leave to dry. A squeegee should not be used. As the starch shrinks in drying, so the print is drawn into the grain of the paper; when dry, the two may be separated.

MODIFICATIONS OF DEVELOPMENT.

For development of carbon prints commercially, a large wooden trough is used, the temperature of the water being controlled to a nicety by the aid of a geyser. The trough is partly filled with moderately warm water, in which the prints are laid to soak. When stripped, they are flushed with the water from the geyser, the temperature of which is controlled according to the appearance the print shows with reference to exposure. Local development can be carried out in this way by spraying the part which appears too dark until it is washed to the correct depth. In working on a small scale, the same method may be adopted by pouring water from a kettle kept at hand on the stove. A tuft of cotton-wool moistened in the water may be applied with extreme care to the portions of the picture which require doctoring up; but this is an exceedingly delicate operation, and should be attempted only by experienced workers. Should the whole picture show obstinate signs of over-exposure, a few drops of ammonia may be added to a little boiling water and the print allowed to remain in that. The action of the ammonia is to reconvert the oxidised organic matter into a more soluble condition. Should the print show

signs of under-exposure, plunge it at once into cold water and develop at the lowest temperature possible.

FINAL TRANSFER.

It will be understood that in the double transfer process the temporary support is waxed, the tissue squeegeed down upon it, and the development carried out, in precisely the same way as in the single transfer. The pictures when dealt with should be stood aside in racks and allowed to dry. When dry, they are immersed in warm water, and with them a piece of final support. The water should not be hot, but merely sufficiently warm to dissolve the soluble gelatine on the surface of the support. Directly this solubility is apparent the paper should be brought into contact, which will probably be thirty seconds after immersion. This must be done under the surface of the solution. They are then withdrawn together, laid on a slab, and stroked into contact with a squeegee, and again stood aside to dry. When dry, they will once more split off the support and are ready for mounting.

OTHER SUPPORTS.

It will be seen from the foregoing that carbon tissue may be transferred to a variety of substances, amongst which opal, ivory, and metal figure largely. Carbons on ivory are much used as a basis for the best miniature portraits.

TRANSPARENCIES AND OPTICAL LANTERN SLIDES.

For making transparencies, a special tissue heavily coated is prepared, which requires considerably more printing. As pictures on glass can be viewed from either side, it is customary to make these by the single transfer process. An ordinary dry plate, from which the silver has been removed in a hypo. bath and then immersed in a solution of potassium bichromate and dried in daylight, may be used as a final support, or it may be coated as described on page 195. Optical

lantern slides are made in the same manner, and are exceedingly popular, owing to the wide range of colours they afford. Two colours, if desired, may be combined—one in the picture itself and one on the cover-glass. Carbon transparencies are especially suitable for enlarging from, owing to the exceedingly fine grain. All the best work in making enlarged negatives, and duplicating negatives of value, is done by the aid of carbon transparencies.

INTENSIFYING CARBON TRANSPARENCIES.

Carbon transparencies may be intensified with pyro. and silver, and other reducing agents, if the transparencies have a preliminary bath of ammonia nitrate of silver. The formula for the preliminary bath is: Silver nitrate, 3 grains; distilled water, 1 pint. Dilute ammonia is added to dissolve the precipitate formed when the ammonia is first added. One minute's immersion will be sufficient, and, after washing, the transparency may be treated with pyro. and silver. The above bath may be used repeatedly. The change is very rapid, therefore very weak solutions should be used; 2 or 3 drops of a 3-grain pyro. and citric acid intensifier, with one drop of a 5-grain solution of silver nitrate, make a suitable mixture.

ENAMELLED CARBONS.

This process has lately been revived. It consists of the production of an enamelled-surface carbon similar to a very old process called Lambert-type. A sheet of glass is carefully cleaned with soap and water, and when dry either dusted over with French chalk or rubbed over with a little beeswax and turpentine, as described for double transfer (see p. 195). The glass is then coated with enamel collodion, applied in the same way as varnish to a negative (see section on Preparing the Negative, p. 151), care being taken to avoid "crapiness" (or a streaky, crape-like effect on the surface), by rocking it gently in pouring back into the bottle. The collodion should be washed till all greasiness has disappeared. The tissue must be squeegeed down and

developed upon this support, and when afterwards the final support is mounted over it, it splits away from the glass, bringing with it the collodion film, which imparts a very high glaze and protects the picture beneath. Whether this glaze is or is not an advantage must be left to the taste of the operator himself to decide. A collodion film with a matt surface might be used instead, by having ground glass for the support. Such prints are much in favour for enameloids.

PHOTOGRAPHIC BUTTONS.

These are usually obtained by mounting face down on a sheet of celluloid or insoluble gelatine, from which they are afterwards punched, so as to leave a clean edge and no evidence of the film. The print is laid on a metal disc and placed in a press, whence it issues as if actually formed in the metal itself. In developing these prints clear glass may be used as the support, but opal glass is much to be preferred, as otherwise it is difficult to judge the image.

INTENSIFYING CARBON PRINTS.

Carbon prints cannot be intensified by any of the chemical processes employed for other prints; but it is possible, in some cases, to change the image to a more opaque substance by staining. Any dye that may be relied upon to act equally throughout the gelatine may be used. Permanganate of potash, or pyrogallic acid and silver nitrate, are capable of strong staining action suitable for the purpose. The strength of the permanganate is immaterial so long as it is fairly dark, and the silver pyro. bath may be used as directed for the wet-plate process (see section on Intensification). Nigrosine or aniline black may also be employed.

CARBON PROCESSES WITHOUT TRANSFER.

Like other carbon processes, these are based on the oxidising action of the chromium salts. Ever since the introduction of the carbon process, experimenters

have been trying to find a method which should give directly—that is, without transfer—a picture in carbon and gelatine equally permanent and with the same beauty of gradation, and one in which the image need not be reversed. The first efforts were made in the direction of sensitising the back of the tissue, but the results were by no means satisfactory. A process to some extent fulfilling these conditions was invented by John Pouncy in 1859, but did not find much favour. Apparently this was due to the uncertainty of the process, the waste of time occasioned more than counterbalancing that occupied by the extra operations. These various processes are based upon the continuing action of light, or the fact that the peculiar effect of the potassium bichromate could be conveyed from one film to another. The processes are the Gum Bichromate, the Artigue or Carbon Velours, and the Ozotype, the last named having some further claims.

CONTINUING ACTION OF LIGHT.

The action set up by light in a colloid substance when impregnated with chromic salts continues in a less degree even after the substance is removed from the light; that is to say, a print exposed for a part of the proper time and then kept for a while in the dark before development, would afterwards be found to be fully exposed. It was therefore natural to argue that this hardening effect might be conveyed to a film which had never been in the light at all, and that the image might be formed by one paper and developed by means of another. On this basis the various processes under consideration were founded. This continuous action, it was discovered, proceeded even though there were no free bichromate present in the film. This discovery was of great importance, as it became possible to keep the printed image—or, rather, the basis—for four or five months between printing and developing. Thus the chemical action may be started in one substance, conveyed to another either with or without free bichromate,

and the second substance and the one actually holding the pigmented image may differ entirely from the first. For example, the image may be (a) produced straight away on pigmented gum; or (b) on gelatine only, and afterwards formed in gum and pigment; or (c) on paper only, and afterwards in gum, starch, or gelatine.

GUM BICHROMATE PROCESS.

A large variety of methods have been suggested, and there seems to be considerable latitude in formulæ and mode of working; especially if the smeary indistinctness, which in some minds has become associated with the process, is admired. The following method is one of many:—A sheet of Whatman's drawing paper, or other suitable paper, is sensitised by immersion in a 5 per cent. solution of potassium bichromate, and dried. It is then coated with a mixture of gum and pigment, and exposed beneath a negative, the exposure being timed by means of an actinometer. To develop the print, it should be laid face down in a deep dish of cold water, and allowed to float in this manner for five or ten minutes. The gum and pigment should very gradually soak off the unexposed portions. Development may take hours in some cases, but this will depend on the length of exposure and temperature. It is best, however, not to hurry it. At the end of each ten minutes or so it may be examined, and treated in accordance with its condition. Development may be hastened by laving it with water, or in some cases by gentle treatment with a large camel-hair mop. In extreme cases, it may even be advisable to stipple down the deep shadows with the brush full of water. All the time the print is face upwards it should have a gentle stream of water flowing over it. On no account should the print be allowed to remain face up to soak. When developed, the print is fixed in a solution of common alum—strength immaterial—and dried. Instead of alum, either hypo. or soda sulphite may be used. It has been claimed for this process that it lends itself above all others to artistic modifications,

but for extreme latitude in this direction it cannot equal the dusting-on process (see p. 201).

ALTERNATIVE METHODS.

Instead of working the process as described above, it may be done as suggested by Marion in 1873. The transfer paper is sensitised in the usual bichromate bath and a visible image printed. The carbon tissue and print are then immersed together in a 2 per cent. solution of potassium or ammonium bichromate and squeegeed together. After remaining for a time under pressure until nearly dry, the picture is developed as described for the single-transfer process. This, however, is hardly a gum process, though very similar in principle, and it is altogether too uncertain for commercial work. The following gives better results:—Take some double-transfer final supports—or paper prepared as described on p. 195, omitting the alum—and sensitise in a 3 per cent. solution of potassium bichromate for about three minutes, according to the character of the result desired. It should then be dried, taking the usual precaution against fumes. Instead of the transfer paper, ordinary cartridge paper, such as Joynson's, may be employed. If the plain paper is used, a stronger solution (say 10 per cent.) may be used for sensitising. Next dissolve 2 oz. of Turkey gum to make a 40 per cent. solution, and mix with this sufficient colouring matter to give a pretty dark surface. The pigment must be fine and absolutely free from grit.

COATING THE PAPER.

The paper is not intended to have a heavy coating of pigmented gelatine, as in the carbon process, but merely an extremely thin layer just equal to the deepest shade required in the picture, or a little darker. For the pigment, the ordinary distemper colours may be employed; but as they generally require more grinding to get them in a proper condition, it is preferable to use the moist water-colours obtainable in tubes. In any case, see that the colour is thoroughly

well mixed with the gum. The mixture is applied with a brush—preferably a fan-shaped badger-hair—and dried in the dark. In this condition the paper will keep only a few days. When the image is first printed upon the paper only, or on paper coated with gum gelatine or starch, bichromated, and then washed free of the bichromate, the paper may be kept a considerable time before development. Printing being complete—which may be timed with a strip of P.O.P. over a negative of similar density in the early trials, giving the gum paper one-fourth longer—the paper must be developed.

DEVELOPMENT.

This consists in removing the superfluous colour, and may be done by washing,

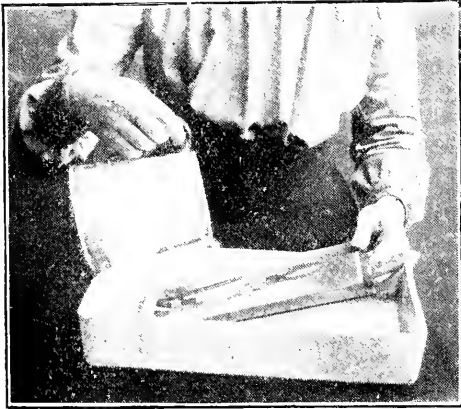

Fig. 301.—DEVELOPING ARTIGUE PAPER.

soaking, spraying, or light rubbing. The first and second are the safest methods. Allow it to soak for half an hour; then take up the print by one corner and note the progress. If it does not develop quick enough, it may be hastened by adopting one of the other methods. When developed, place it in the alum bath—strength immaterial—for a few minutes and then wash and hang up to dry. As commercial alum often contains dirt, it is advisable to decant off or filter the alum bath; in any case, it should be given ample time to settle. Once the dirt has settled on the print, it becomes immovable.

THE ARTIGUE PROCESS.

This is a kind of gum bichromate process introduced by M. Artigue in 1892. The results produced in expert hands are certainly very fine, and quite equal to ordinary carbon prints. The paper is coated with a mixture of pigment and some organic substance, and is sensitised in a solution of potassium bichromate. Drying and printing are carried out in the manner usual in the carbon process, and development is effected by first soaking the paper in water for a few minutes, and then pouring from a jug with a fine lip a mixture of sawdust and water over the print, which is supported during the operation on a sheet of glass (see Fig. 301). The roughness of the sawdust causes the colloidal matter to leave the paper more readily, but the print must occasionally be returned to the water bath below in order that the progress of the development may be ascertained. Fixing, drying, etc., is then carried out as usual. The image is produced by development, so that an actinometer must be used for timing the exposure. This timing of exposure by means of an actinometer, however, is not by any means so serious a drawback as may be imagined; in fact, by arranging the frames into groups, it is possible to time a large number with the same actinometer, particularly if a graduated scale, such as Wynne's, is employed (see p. 189).

THE OZOTYPE PROCESS.

The paper for this process can be purchased ready for use. It is said to be ordinary paper sensitised in a solution of bichromate of potash, manganous sulphate, alum, and boric acid. This paper is exposed beneath a negative, of the class usually employed for similar processes, until a brown image appears, showing just a little detail under the densest parts. The image produced is a positive, and so forms a direct guide as to the printing action which has taken place. Next a sheet of ordinary carbon tissue, or some such pigmented colloidal substance, is immersed in a solution

of hydroquinone, acetic acid, and ferrous sulphate, and squeegeed down upon the printed support, which has previously been coated or immersed in a 2 per cent. solution of gelatine. The time of immersion in this bath is one minute, and the prints may be immersed with it and the two withdrawn together in contact. The squeegeed print is then allowed to dry, which should not take too long, and is soaked in cold water for about twenty minutes. It is then developed in the same way as already described for single transfer. After development, the print merely requires washing in cold water, and may be dried, face up, on blotting-paper.

MATERIALS REQUIRED.

The novice will, of course, succeed best with ready-prepared materials. A 2-oz. bottle of sensitising solution, sufficient to cover 24 sq. ft. of surface, costs 1s. This area can only be covered by applying the solution with extreme care with a brush. Pigment plasters may be obtained of the colours usual for carbon tissue, including special brown, sepia, warm sepia, red chalk, engraving black, warm black, marine blue, sea green, and terra-cotta. They are supplied in bands or in cut sizes. A dozen pieces half-plate size cost 1s. Sample packets containing a variety of colours may be obtained. Special brushes are sold for coating, but any fair-sized flat brush (such as that shown in Fig. 302), if perfectly clean, will answer the purpose. Special paper for coating is also supplied, three sheets costing 1s. Double transfer final supports may be used instead, and ordinary carbon tissue instead of the pigment plasters. The solution for soaking the tissue consists of hydroquinone, 10 grs. ; acetic acid, $\frac{1}{2}$ dram ; water, 1 pint.

IMPROVING NEGATIVES.

In the case of hard negatives, the high lights are apt to wash away, and to avoid this the inventor of the process, Mr. Thomas Manley, has suggested the addition of from 20 to 100 minims of a 10 per cent. solution of copper sulphate. The

softer the negative the less copper is to be used, as by its aid the action will penetrate farther into the shadows. It is important to bear in mind that success in this, as in all other carbon processes, depends upon hitting the precise balance of solubility. It is a common fallacy to suppose that the action of light renders certain parts

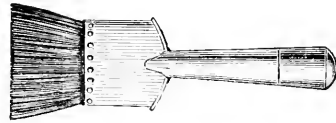

Fig. 302.—BRUSH FOR DUSTING-ON PROCESS.

insoluble, whilst others remain soluble. Although this is true in one sense, it would be more correct to describe it as causing different degrees of solubility, the gradation being dependent upon the exact variation of solubility. All parts of the image are soluble if given sufficient time, whilst all parts are insoluble if developed too briefly or in too cold a bath.

DUSTING-ON PROCESS.

This is sometimes called the "powder process." Like other carbon processes, it is based upon the oxidising action of chromic salts upon organic matters. This is indicated, in the present instance, by the fact that the organic matter loses its tackiness or stickiness under the action of light, and refuses to retain dust. The process is much used for photo-ceramics and for the intensification and doctoring of bad negatives, where these are of great value. A fine and soft camel-hair brush (Fig. 302) is used for brushing over the powder. The exact size is not important. There will also be required some pieces of ground opal or pot opal the size of the picture (it is best to begin with half-plate size); a few dishes, such as are usually at hand; some powder in a very fine state of division; a transparency; and the sensitising mixture.

MAKING THE TRANSPARENCY.

It will be noted that as the effect of the light is to cause the film to refuse the

powder, the parts acted upon by the light will remain lighter. This being the case, an impression taken from a negative would give a negative, so that if the finished

ties will, of course, be presented for making use of this fact, such as where a negative is required to be reproduced. Moreover, the negative will be reversed as regards right and left, and as the contrast and gradation, as well as the rendering of large masses of shadow or light, are entirely under the control of the operator, it provides an excellent means of producing negatives for use in the single-transfer process. This offers the further suggestion that to secure the truest rendering of an object by the process, it will be necessary to have a reversed transparency, and the process by which one may be produced is at once indicated—namely, the single-transfer. In making this transparency, it is essential to bear in mind that it should have the same class of gradation, tone, and contrast as would be looked for in a negative, a transparency of the ordinary kind being too thin and weak. Therefore, it should be printed and developed to look decidedly dark, as otherwise the detail in the lights will have little contrast, and consequently little chance of properly impressing the plate. The subject chosen should be one showing a pleasing variety of tones, full of detail in the lights and with great transparency of shadow—plenty of clear contrast, in fact, throughout the picture, without any approach to hardness. A weak subject lacking in contrasts, or of a monotonous tone, will present only a dirty picture.

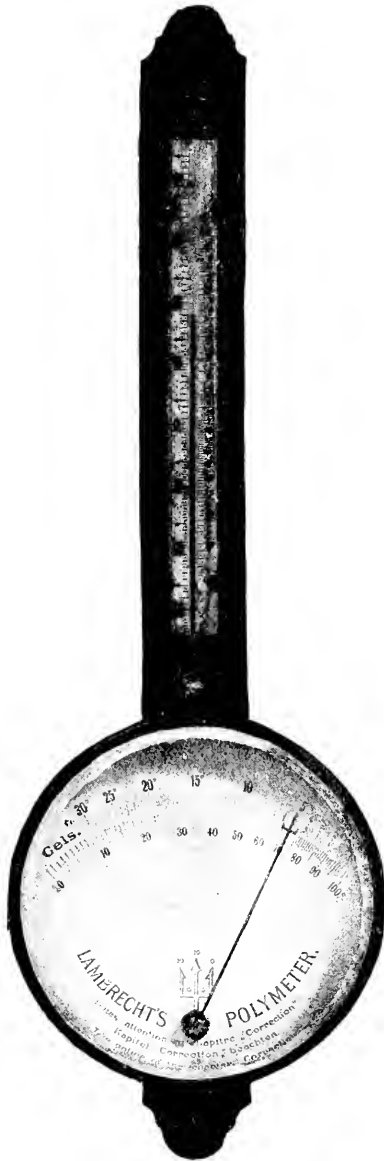

Fig. 303.—HYGROMETER.

SENSITISING MIXTURE.

The following formula is as good as any, but it should be understood that between the multitude of formulæ available there is very little to choose. White sugar, 200 grs.; gum arabic, 250 grs.; ammonium bichromate, 200 grs.; methylated spirit, 1 oz.; water, 20 oz. Every formula must contain a gum, a hygroscopic substance, and a sensitiser, and beyond this it does not appear to matter much. A hygrometer (see Fig. 303) in the room in which the work is done is an assistance but not essential. The proportion of hygroscopic substance in the mixture may then be varied according to the atmospheric conditions

result is to be a positive, as is usually the case, a transparent positive must be used for printing from. Many opportuni-

indicated by the hygrometer. The gum and sugar, which must be pure and of good quality, should be covered by the water and dissolved by heat. When thoroughly dissolved and cooled down, add the ammonium bichromate and the methylated spirit. The quantity of spirit is not arbitrary, but as it is used to allow the solution to flow more evenly, it may be increased or reduced as found necessary. The sensitive solution thus made will last only a few days, but without the addition of the bichromate it will keep indefinitely, especially if 2 grains of mercuric chloride are added. Any quantity may be kept made up, and then, to render the solution sensitive, it is merely necessary to add the ammonium bichromate. Other formulæ are: Dextrine, 110 grs.; sugar, 110 grs.; bichromate of potash, 120 grs.; water, 5 oz. Albumen, 30 grs.; honey, 30 grs.; ammonium bichromate, 50 grs.; water, 5 oz. Honey, 30 grs.; glucose, 60 grs.; albumen, 50 grs.; dextrine, 20 grs.; ammonium bichromate, 60 grs.; water, 5 oz.

POWDER TO USE.

The choice in this regard is almost unlimited; the most essential point to be considered is that the powder must be exceedingly fine, the finer the better. If the ordinary powder colours are obtained from the local oilshop, they should be sifted through a muslin bag. Colour of a permanent hue should, if possible, be selected. The silver gold and bronze powders, as used by letterpress printers, answer exceedingly well, and give really striking results.

SUPPORTS.

Roughly speaking, the supports may be divided into three kinds—opal, glass, and ferrotype; but the term is equally applicable to almost any surface capable of receiving the sensitive coating. The special feature of these supports is that they should provide a proper contrast to the powder. If the metal dust is used, such as silver or gold bronze, the image should be

produced upon a dark background so as to provide the necessary contrast. A ferrotype plate answers well for this purpose if coated with fairly dark varnish, and should be covered with the sensitive mixture and treated as described below.

COATING THE PLATE.

After the support has been cleaned with warm water, it is set aside for an instant to drain, and whilst it is still wet the sensitising mixture is poured over it. This may be done in a dish, or by holding the plate in the hand. The latter is the better method, but is somewhat messy. The excess of solution is allowed to run off, but need not be collected. The plate is drained in a rack for a few moments, and then laid face up in an oven and baked, until bone dry. The operations up to this stage may be carried on in ordinary white light, but as the plate dries it increases greatly in sensitiveness, and should therefore be removed in only a very dull light. So much depends upon atmospheric conditions that an exact measure of sensitiveness cannot possibly be made.

EXPOSING THE PLATE.

As in many other cases, this is the most difficult part of the process. The necessary exposure is best found by experiment, based upon the rough guide here given. With a transparency of average density, exposing to direct sunlight about midday in June, forty seconds may be found sufficient. Using this fact as a guide, obtain a strip of albumenised paper or P.O.P. and a piece of cardboard, as shown in Fig. 304, having a circular patch A in the centre, painted three or four shades of brown, with an opening B to allow of the exposure of a strip of sensitised paper. The plate is exposed side by side with this, and covered in sections by means of a graduated frame (Fig. 305). The exposure of the section is stopped as each tint or number of tints is reached, and on development the part most correctly exposed is noted and marked accordingly. It is then easy to give the correct exposure to the plate.

DEVELOPING THE PLATE.

As the development of the image depends on the absorption of moisture—the absorption, however, being confined to certain parts of the picture—the condition of the plate must be very exact. It should be taken directly from the oven and exposed behind the transparency, so that when removed from the frame it will probably still be warm; if not, it is advisable to warm it. The plate is then held by a pneumatic holder, which must be warmed before being used; or it may be held in the tips of the fingers, or placed in a flat dish. The first named method is, however, the best. Sprinkle a little powder in the centre of the plate and with the camel-hair brush spread it as rapidly

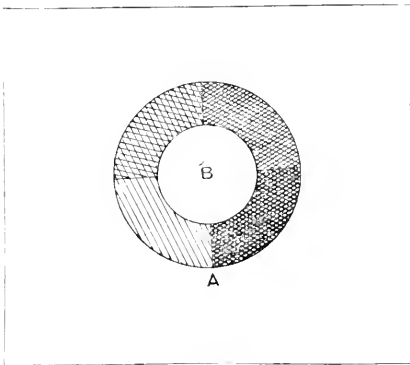

Fig. 304.—SIMPLE ACTINOMETER.

as possible all over the film. This must be kept on the move the whole time, until all the required detail and density is secured. It will be found on removal from the frame that an image is already formed, but this will be where the light has acted. As soon as the plate has become quite cold, development may be expected to commence, and then to proceed fairly rapidly. As it advances, a gentle stream of air should be blown with the mouth across the plate—not so briskly as to disturb the powder, or so slowly as to cause the moisture of the breath to condense upon it. In stubborn cases slow

breathing may be resorted to, but it is a dangerous practice, and liable to produce dirty high lights or a smudgy effect. It is necessary, however, that the air should not be absolutely dry and that the powder is kept constantly moving. This operation may be carried out in the dark-room, where the air is generally in a good condition for the purpose. As soon as the development of any part is complete, the powder may be brushed away, and other parts may, if desired, be allowed to develop further. In this way the artistic effects can be greatly heightened.

COMBINATION PICTURES.

The background from one picture and the figure from another may be combined

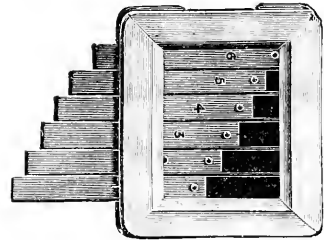

Fig. 305.—FRAME FOR GRADUATED EXPOSURES.

quite easily by proper handling of the brush. Parts of two separate plates are printed in combination, only those parts which are required being dusted with the powder. The combined impression is then laid face together and bound up. For certain pictures it is essential that the one image is reversed, as they have to come together in contact. When, however, a negative is being made which has afterwards to be reproduced through the camera, it need not be reversed, but both may be turned the same way, and by using a small stop the two can be rendered sharply together.

FIXING THE IMAGE.

When the image is developed, it should be coated with plain collodion and washed

fill free from greasiness; it is then transferred to a 5 per cent. solution of potash alum until the yellow bichromate salt has been removed. Fixing is not absolutely necessary, or even advisable, when a reproduced negative is to be made. All that is necessary is to expose it again to the light to get rid of all further tackiness. When it is not convenient to coat the plate with collodion, it may, if desired, be washed over with the following solution: Water, 1 oz.; sulphuric acid, 2 drams; and methylated spirit, 2 oz.; mixed in the order given. The acid should be poured gradually into the water, not the water into the acid. The solution is allowed to wash the plate until all yellowness has disappeared. The latter method is not recommended, as there is a great risk of failure, and it sometimes results in losing the image altogether. It may be pointed out that a flat effect indicates over-exposure of the plate, but this appearance may also result from dryness of the air or overheating.

OTHER APPLICATIONS OF THE ACTION OF LIGHT ON THE CHROMIUM SALTS.

The action of light on these salts also forms the basis of collotype, photo-lithography, and, in fact, all photo-mechanical work; but as these processes will be fully dealt with in the section devoted to Applied Photography, whilst the action of light on such compounds will be dealt with elsewhere from a theoretical point of view, nothing further need be said here.

THE PLATINOTYPE PROCESS.

The exceptional stability of platinum is beyond question, being superior in this respect to gold. If two pieces of platinum foil are suspended, one in nitric acid and the other in hydrochloric acid, neither will dissolve: in fact, it requires a mixture of the two acids, or "aqua regia," to effect its solution. Platinum does not oxidise, so far as is known, at any temperature, and is practically unaffected by either sulphur or chlorine. These facts show it to be an ideal metal for the production of a photo-

graphic image, for silver will not resist either of these tests.

SALTS OF PLATINUM.

Unfortunately, the salts of platinum are too insensitive to be of much direct use in forming a photographic impression, but the possibility was discovered, in the early days of photography, of depositing platinum upon an image already formed in silver, and to some extent replacing the latter (see section on "Printing-out Processes and Papers"). It remained for Mr. W. Willis to hit upon the ingenious plan of first producing an image in the salts of iron, and building upon this so strong an image that the first might be removed without apparent loss. As the chemical action of light upon the salts of iron form the basis of the platinotype process, this must first be considered.

SALTS OF IRON.

Iron compounds may be divided into two groups, ferric and ferrous, or, as they are still sometimes called "per" salts, and "proto" salts. The latter differ from the former in the respect that they contain a smaller quantity of oxygen, and therefore a greater proportion of iron. For example, the chemical formula of protoxide of iron is Fe O , or 1 atom of iron joined with 1 atom of oxygen. The peroxide or ferric oxide contains 3 atoms of oxygen to 2 atoms of iron, and is written Fe_2O_3 . Under ordinary conditions, ferrous compounds have a decided tendency to become oxidised, or to raise themselves to the ferric state, by absorbing the oxygen from the air, or from the water when in solution. This property is reversed by the action of light, and the ferric compound is reduced to the ferrous. Now the ferrous compounds are able to effect changes which the ferric cannot accomplish, as, for example, the throwing down of a rich blue precipitate from a solution of potassium ferricyanide, called "Turnbull's blue." So that if a paper coated with a ferric compound be exposed beneath a negative, those parts where the light acts - that is, the shadows -

will become changed to the ferrous state, and may be made visible by treatment with some substance showing a certain reaction with only one of the compounds.

AN EXPERIMENT

will make this clear. Prepare two 25 per cent. solutions: (No. 1) citrate of iron and ammonia, and (No. 2) red prussiate of potash. Coat a sheet of white paper with the first by stroking it over with a brush made like Fig. 306. This consists of a strip of swansdown calico folded over and attached by a rubber band to a piece of wood forming the handle. Fasten the paper flat on the table with a drawing pin at each corner. The strokes of the brush should run one way and overlap. A slight unevenness is of no consequence, provided the paper is well covered. When dry, expose until a

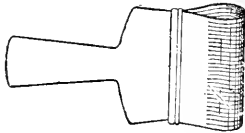

Fig. 306 —BRUSH FOR SENSITISING PAPER.

faint brown image appears—probably in about twenty minutes in bright sunlight; then place in a dish and flow over the second solution. Instantly the picture will flash up, giving a vivid impression in prussian blue. In preparing solution No. 2, it is advisable first to swill the crystals before dissolving in order to get rid of any ferrocyanide with which they may be coated. Blue prints made in this manner merely require to be passed through a weak (say $2\frac{1}{2}$ per cent.) solution of citric acid, and washed, to complete (see section on "Printing-out Processes and Papers").

PLATINOTYPE A TONING PROCESS.

Something similar to this occurs in the platinotype process. If to the ferrous compound is applied a solution of platinum, under certain conditions metallic platinum is deposited on the image in a similar way to which gold is deposited on a silver image

in toning. Platinum is therefore a means of toning iron prints. Chrysotype, a process invented by Sir John Herschel, was a similar plan of toning iron prints with gold; but in this case the gold was directly precipitated. Platinum would not be, but would require the addition of potassium oxalate to bring about suitable conditions. There is one great difference between this and other toning processes. In gold toning an alloy is formed with the metal composing the provisional image, but in the case of platinum the whole of the iron is replaced by the more stable metal, and the permanency of the image thus rendered complete.

USE OF POTASSIUM OXALATE.

The reader will naturally want to know why it should be necessary to use potassium oxalate. If paper is coated with ferric oxalate and a salt of platinum, and then exposed to light, a faint image will be produced, due to the reduction to the ferrous state of the iron oxalate, but the platinum will be unaffected. If to a solution of sulphate of iron is added a solution of potassium oxalate, a yellowish precipitate at once begins to fall which is insoluble, but on adding more potassium oxalate it is redissolved. This shows, then, that ferrous oxalate is a body ordinarily insoluble, but one which may be dissolved with excess of potassium oxalate. To obtain an action between two such bodies as platinum and ferrous oxalate, one of them must be in solution, and by immersion in potassium oxalate this condition is effected:—

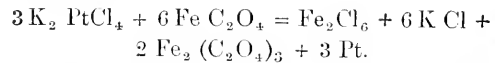

(Potassium chloro-platinite + Ferrous oxalate = Ferrous chloride + potassium chloride + Ferric oxalate and Platinum.)

AMMONIO-FERRIC CITRATE.

A number of iron compounds are sensitive to light, including ferric chloride, ferric oxalate, ammonio-ferric oxalate, potassium-ferric oxalate, ferric tartrate, ammonio-

ferric tartrate, and ammonio-ferric citrate. Although not the most sensitive, the last-named is best known, being that commonly used in the ferro-prussiate or "blue printing" process. Paper brushed over with a 25-per-cent. solution of ammonio-ferric citrate shows a faint brown image, which turns a deep blue on the application of a 25-per-cent. solution of potassium ferricyanide. If preferred, the two solutions may be mixed, when the image prints out blue without development. Paper so prepared merely needs washing in water to fix the image. It is advisable to place the print in a 1 in 40 solution of citric acid for a few minutes, and then wash for ten minutes. The light changes the iron salts from the ferric to the ferrous state. In the above case ammonio-ferric citrate is changed to ammonio-ferrous citrate, and on the application of potassium ferricyanide iron ferricyanide is formed. If under-printed, the print may be intensified in a weak solution of a ferric salt, or, if over-printed, reduced in weak carbonate of soda. A more energetic reducer or bleacher suitable for local treatment is a weak solution of potassium oxalate. The paper can be toned to various colours in sulphocyanide, strong tea, gold chloride, or silver nitrate.

FERRIC OXALATE.

Of the several iron salts available for platinum printing, the ferric oxalate is chosen on account of its superior sensitiveness. Under the action of light it is changed to the ferrous state by the liberation of carbon dioxide. Ferric oxalate has no action on platinum salt, but ferrous oxalate instantly reduces it to the metallic state. In an early platinum process the platinum was applied to the print in the form of a developer, but modern paper is coated with both the ferric and the platinum salts.

COATING AND SENSITISING THE PAPER.

The manufacturers' method of preparing the paper is preserved a secret, but experimental work may be done as follows. Any

pure sample of paper, stout but of smooth surface, should be sized with arrowroot 1 oz., gelatine $\frac{1}{4}$ oz., alum $\frac{1}{4}$ oz., and water 80 oz. The arrowroot should be mixed to a stiff paste, and the gelatine and alum dissolved in separate portions of the water. The bulk of the water is then made hot and the arrowroot poured in, the other ingredients following. The paper is then drawn into the solution, in a way similar to soaking a bromide print before development, to avoid air-bells; it is then allowed to remain in the solution about three minutes. The paper is next pinned out to dry, and when dry may be sensitised. Prepare two solutions: (No. 1)—Ferric oxalate 16 grs., oxalic acid 1 gr., and water 50 minims; (No. 2)—Chloroplatinite of potassium 15 grs., and water 90 minims. For use, take of No. 1, 22 drops, No. 2, 24 drops, and water 4 drops. The ferric oxalate being sensitive to light, all the operations involving its use must be carried out in a feeble yellow light.

PREPARATION OF FERRIC OXALATE.

Ferric oxalate is an extremely unstable compound, and difficult to procure, so that the experimenter may have to prepare it. In any case, it must be tested from time to time by taking a small quantity in a test tube and adding a few drops of solution of ferricyanide. If this turns blue, the presence of ferrous salt is indicated, whilst if the oxalate is in proper condition it will turn brown. To prepare ferric oxalate, in 4 oz. of water dissolve 333 grs. of pure ferric chloride (this must first be tested for the presence of ferrous salts as just described), and add about $\frac{1}{2}$ oz. of strongest liquid ammonia. There must be a slight excess of ammonia to ensure the complete conversion of the ferric chloride into the red-brown insoluble ferric hydrate. Perform this operation in a beaker with a lip, stir vigorously, and allow to stand for a time. A good plan is to put the precipitate in a well-washed linen bag and dissolve in the same. It may then, after standing, be pulled together and the water wrung out of the precipitate. Next wash the precipitate with boiling water by filling up and wring-

ing out repeatedly, until the solution is no longer alkaline when tested with red litmus paper. Now add about 270 grs. of crystallised oxalic acid to dissolve the precipitate. The action takes place slowly, and the solution should be left to stand for a few days in the dark. The exact quantity of ferric oxalate produced will depend on the purity of the chemicals and the care with which the operations are carried out. To determine accurately the strength of the solution, which should be a yellowish green, involves some knowledge of quantitative analysis, but it will suffice if the solution is made up to 700 minims, when it will be practically the No. 1 solution given above.

APPLYING THE SOLUTION.

The paper should be wrapped round a sheet of glass, and the solution rubbed

the joint. The calcium chloride mixture is dried over a Bunsen burner (or in a shovel over the fire) and wrapped in muslin, thus preventing any particles coming in contact with the paper. Greasing the ends of tubes makes them more air-tight. Calcium chloride is very greedy of moisture, its function being to keep the air dry within the tube; it soon becomes soft, and should then be redried until white. If the paper is allowed to become at all damp the prints will be flat and weak.

KIND OF NEGATIVE REQUIRED.

The negative should possess a fair amount of contrast with good gradations. A "pluckier" negative is required for P.O.P., but it must not be so strong as that necessary for the plain salted process. Softer prints can be obtained

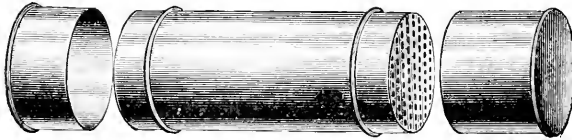

Fig. 307.—CALCIUM TUBE.

evenly into the pores with flannel, but without using sufficient force to disturb the surface of the paper. About 1 dram of solution may be made to cover a sheet of paper about 2 ft. square. The paper should then be thoroughly dried, which operation should be timed to take five minutes.

STORING THE PAPER.

Directly the paper is surface-dry it should be warmed, and must then be stored in an air-tight tin. Such tins consist of a tube (Fig. 307), containing the paper, covered by a cap, the joint being enclosed by a broad rubber band. Separated from the tube by a sheet of perforated zinc is a second chamber, containing calcium chloride made into a paste with asbestos. Entrance to this chamber is effected by removing the cap, a rubber band covering

from a hard negative by raising the temperature of the developer, while brighter prints result from a weak negative by adding to the developer a small quantity of sodium hyposulphite. Negatives which have clear glass shadows are liable to solarisation, which may be avoided by shading up those portions during printing.

PRINTING.

In printing, the paper is placed face to face with the negative, covered with a sheet of rubber backing to exclude moisture, and exposed sufficiently long to show the lights faintly on a pale yellow ground. Plate IX. will give a good idea of the appearance of a correctly exposed platinotype print. The exact depth of printing is best found by experience. A strip of platinum paper

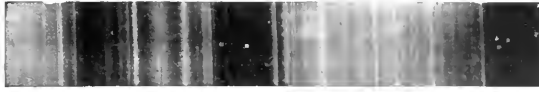

I. Spectrum of Arc Light with various salts, showing Fraunhofer Lines.



II. Spectrum showing position of Sodium D Line.



III. Spectrum through a Blue Violet Filter.



IV. Spectrum through a Green Filter.



V. Spectrum through a Red Filter.



VI. Spectrum through a Blue-Violet Filter.

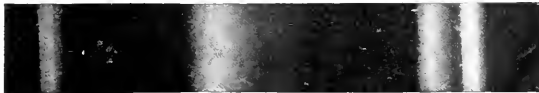

VII. Spectrum through a Green Filter.



VIII. Spectrum through a Red Filter.



IX. Spectrum through a Blue Filter.



X. Spectrum through a Yellow Filter.



XI. Spectrum through a Red Filter.

Example of Light Filters which are correct when used with plates sensitive to *all* rays of the spectrum.

Example of Light Filters which must be used with plates sensitive to *certain* rays of the spectrum, and therefore showing incorrect bands of absorption if used with plates sensitive to all rays, as in this case.

Filters for Collodion Emulsion sensitized for certain rays of the spectrum. The bands of absorption are to cooperate with the insensitiveness of the plate for certain spectrum rays.

may be used as a guide, and if this negative be covered with a mask of brown paper having a small hole, it may be used to take several "tints" side by side, which are easily compared, and serve as aids in getting several prints from the same negative of even depth. Platinum paper is about twice as quick as P.O.P. It is better to cut the paper than to tear it to size.

DEVELOPING.

In development, the paper, on coming from the frame, is lowered, face down, quickly and evenly, into a hot saturated solution of potassium oxalate, and development is instantaneous. There is little or no control possible beyond alterations made to the developer beforehand. The developed prints are placed one by one in a 1 in 60 solution of hydrochloric acid; this dissolves out the faint iron image, without apparent loss of intensity, and the iron must be thoroughly removed, as any residue would cause the whites to turn yellow. It is imperative therefore, that pure and not "commercial" hydrochloric acid be used, as the latter already contains iron. The prints should be passed through three successive baths, remaining three minutes in each, before the final washing for fifteen minutes. Soft water is preferable for washing, and may with advantage be made slightly alkaline with a little washing soda. The paper now in general use develops in a cold solution, although many workers prefer it slightly warmed. The print may be pinned to a board or laid on a glass and developed with a brush. Glycerine applied to certain portions prevents the developer sinking into them rapidly, and allows the other parts to approach them in printed effect. Sepia platinum paper may also be purchased, or sepia tones may be produced on the paper described herein by the addition of sufficient of a saturated solution of mercuric chloride to the developer. Further details of commercial papers are unnecessary, as directions for their use are supplied by the manufacturers. The developer recommended is different, in some cases, from that given above.

LOCAL DEVELOPMENT WITH GLYCERINE.

It sometimes happens that in spite of all the care bestowed upon the preparation of the negative, and the proper shielding of the various parts, the image is inclined to develop up too darkly in certain parts before the requisite amount of detail has been secured beneath the denser portions. In such cases local development with glycerine is of great service. This is an exceedingly simple operation. The prints should be supported on a glass, and the shadows painted over with glycerine. Three measures or cups are then filled as follows: No. 1 with a strong developer; No. 2 with a weaker developer, together with an equal quantity of glycerine; and No. 3 with a very dilute developer, with glycerine. The strong developer is painted over the portions which are likely to be too light, and then the other parts are rapidly mopped or brushed over with the diluted solutions in proportion to their intensity. Care should be taken to blend the patches together, to prevent any chance of a line appearing; although there is not very much fear of this, as the solutions are inclined to spread of their own accord and soon catch up to each other. A rough print should be at hand as a guide during the development, and the operator should make up his mind exactly as to what he intends to do, and the effect to be produced, before starting. Development should be stopped the instant the required detail is out in the high lights. This method of procedure, carefully carried out, places a very effective control in the hands of the operator. It is even possible, where the background is light, to vignette a print in this way. It must be understood, however, that the method is less valuable in the case of small prints. Pictures smaller than whole-plate can seldom be treated very successfully, whereas prints 15 in. by 12 in. and over can be doctored to a considerable extent. The process is not greatly used in commercial work, for where extreme care is taken in shading up and preparing the negative, it is only seldom that occasion arises for its use. Other acids besides hydrochloric have been suggested for

fixing; but the hydrochloric acid, if pure, is far superior to either acetic, sulphuric, or nitric. Prints should always be fixed face downwards, as this prevents the iron sinking into the paper.

CONTROL OF CONTRAST BY DEVELOPMENT.

Within certain narrow limits the contrasts of a platinotype print may be controlled by modification of the developer. For example, if a solution of potassium oxalate only is used, development takes place on the shadows and on the lights more equally, resulting in less contrast. On the other hand, if a solution of potassium phosphate only is used, only the deeper shadows are acted upon, with a consequent increase of contrast. It is therefore evident that the addition of a certain quantity of potassium phosphate to the normal developer is useful in printing from flat negatives. Besides the physical restrainer already referred to—namely, glycerine—there are the chemical restrainers, potassium nitrate and potassium chloride. The addition of an equal part of a 10-per-cent. solution of potassium chloride, or of 1 gr. to every 10 oz. of potassium nitrate, will cause considerable restraining action. The addition of a small quantity of potassium bichromate solution to the developer will also result in increased contrasts, or produce a hard result if over-done, whilst the citrates tend to give a softer image. These modifications, however, are much more marked with the hot bath process than they appear to be with the newer cold bath. The use of a stronger developing solution will give deeper blacks than a weak one, as the platinum is reduced more readily, although there does not appear to be much difference if a solution of moderate strength is allowed longer to act. It is a good plan to filter the developer after use. It will probably soon be found to deposit white and green crystals by evaporation; the former are crystals of potassium oxalate, and the latter potassium ferric oxalate. In commercial work it is most essential that a negative of proper contrast with well balanced shadows be produced, as con-

stant alteration of contrast leads to uneven results.

REDUCTION.

Little need be said of the reduction of platinum prints, as the process is very unsatisfactory. If the reader wishes to experiment, it may be done by cutting a platinum print in halves and immersing one half in a 5-per-cent. solution of bleaching powder to which a small quantity of acetic acid has been added. Platinum, as already stated, is an exceedingly stable metal, and substances which are able to reduce it would also destroy the paper support.

INTENSIFICATION.

The toning processes are in reality methods of intensification. The prints may be intensified with either gold, silver, or platinum. If gold is chosen, the wet print, after thorough washing, is laid face up on a sheet of glass, and the excess of moisture blotted off and allowed to become almost surface-dry. It is then covered with glycerine, as if for local development. Supposing a 12 in. by 10 in. print is under treatment, 1 grain of gold is added to 30 drops of water and slightly acidified with pure hydrochloric acid. The solution is spread rapidly over the print with a brush. When the desired increase of intensity has been reached, the print may be immersed in a solution consisting of metal 10 grs., soda carbonate 100 grs., water 5 oz. As regards intensification with platinum, the process introduced by Hübl has been found the most satisfactory. It consists of immersing the print for from 10 minutes to half an hour in a solution of sodium formate and platinum perchloride, the platinum being slowly reduced and deposited upon the metallic particles already present. The formula advised is platinum perchloride 5 grs., water 4 drams; sodium formate 25 grs., and water 4 drams. Add these two solutions to 30 oz. of water. Hübl has further suggested a method of toning with ferricyanide of iron, which gives a variety of tones between a slate grey and a bright blue. The colour, however, is not permanent, being easily discharged by dilute alkali-

line solutions, as in the case of uranium toning, but with the difference that when discharged they leave the image in its original state and not reduced. So long as the prints are kept acid and free from moisture, there is no reason why the colour should not be fairly permanent. It is necessary to mount the prints with an acid mountant.

CATECHU AND URANIUM TONING.

A method of staining the platinum print with solutions of different varieties of catechu was once much in vogue. Mr. J. Packham, the patentee of the process, advises the immersion of the print in a hot solution made by adding 30 to 40 drops of a 5-per-cent. solution of catechu to 1 pint of hot water, merely rinsing in water when the action is complete. The uranium bath (described later) may be used for a like purpose, and gives a wide range of warm tones. It is essential, however, that the iron should be very completely removed from the print if anything like a successful result is to be secured. On the whole, the process cannot be recommended, as the uranium is deposited in greater proportion on the lighter tones.

THE SEPIA PROCESS.

As before stated, sepia tones may be obtained by development with the aid of mercuric chloride. This may be added to the developer (as described on p. 209) or more conveniently to the sensitiser. The preparation of platinum paper on a small scale is a very unprofitable proceeding, except as an educational exercise, but the following formula, which has been found satisfactory, may be given, in case the reader wishes to experiment. The paper must first be coated with a 3-per-cent. solution of arrowroot, containing 2 grs. of alum to each ounce. When dry, it may be sensitised with a solution made as follows: 6 parts of a saturated solution of ferric oxalate, 4 parts of a 20-per-cent. solution of potassium chloro-platinite, 1 part of a 5-per-cent. solution of mercuric chloride, and 1 part of a 10-per-cent. solution of sodium chloro-platinite.

THE PROCESS ON SILK AND SATIN.

No special directions are necessary for this application of the process, except that the fabric should be stretched on a light frame made of thin wood, and the exposure timed with an actinometer. This avoids the possibility of creasing and distortion of the image in printing. The manipulations are carried out as usual. The material can be obtained of the Platinotype Co., but only small quantities are supplied. Possibly this has prevented it being more generally used.

TREATMENT OF UNDER- AND OVER-EXPOSED PRINTS.

No amount of doctoring of a print after exposure, at any stage of its production, can equal one which has been exposed for the correct time. By the use of an actinometer, and profiting by experience, the proportion of failures should be small; but a necessity for the employment of modified development is bound to arise occasionally. If the print is under-exposed, the developer may be warmed; or, if used warm already, its temperature may be increased. If, on the other hand, the print is over-exposed, the temperature may be lowered. Under- and over-exposure result in increased and decreased contrast respectively, so that the methods suggested under the heading "Control of Contrast" (p. 210) may be employed. It must be borne in mind, however, that there is a continuing action of light liable to go on similar to that in the carbon process, but in a modified degree. Allowance must be made for this if prints are to be kept for any length of time before development.

HOW TO DEAL WITH OLD PAPER.

Generally speaking, old paper which has been allowed to get damp is best thrown away, but in certain cases it may be used. The best plan is to dry it thoroughly in the oven, and then add to the developer a little potassium hypochlorite or sodium hypobromide. The exact quantities of either of these will depend upon the con-

dition of the paper, and must be found by experiment. It has also been suggested to print the paper right out, and merely fix the image; but this, although practicable, cannot be recommended, as the results are exceedingly granular and the gradations bad. The effect of keeping paper is to flatten or fog the image when printed, and there are other methods which may be employed to overcome this, or by which the contrasts and gradations may be controlled.

THE BROMIDE PROCESS.

Bromide printing is the process of printing by artificial light upon paper coated with an emulsion consisting of gelatine containing silver bromide, similar to that used in plate making, but considerably slower. It will be seen, therefore, that the paper must be worked in the dark-room and that the image is produced by development.

ADVANTAGES OF THE BROMIDE PROCESS.

Of the advantages of the process, none possibly exceed that of rapidity of production, and this alone would have made it a popular one. It is possible to make a finished print by this process, exclusive of retouching, in about half an hour; which rapidity cannot be equalled by any other process. In this way, large quantities of prints may be turned out from a single negative; and now that there are several machines upon the market for rapid printing, the process is worked very extensively. Control of contrast is another advantage of the process, although this is a point upon which photographers disagree. There can be no doubt, however, that in skilful hands the contrasts of a picture may be influenced considerably by the use of proper developer and modification of exposure. Most processes allow of some modifications, and such have already been referred to; but the bromide process allows the greatest latitude, in this respect, of any silver process. Fewness of operations is an advantage that commends itself to the rapidly working professional

as well as to the amateur; the picture developing up a pleasing slate black without the use of a toning bath. Less liability to stain may also be claimed for the process, without apparently much harm resulting. True, it is quite possible to produce severe staining by working in the wrong way or with certain developers, but there are none of those unaccountable stains and markings which so frequently crop up with other silver processes, even when worked on a large scale; some of which are doubtless due to faults in manufacture, but many to local conditions, such as water supply, etc. Moreover, the paper will bear considerable handling, without apparently much effect. On the whole, then, the paper may be said to be much less liable to disturbance from outside influences than those prepared with the chloride.

DISADVANTAGES OF THE BROMIDE PROCESS.

It is possible that points which have been noted as advantages of the process may by some be considered disadvantages; just as some of those which may be pointed out as disadvantages may be thought the reverse. For certain effects, the image exists too much on the surface of the paper, which is the case with all emulsion processes, and for these effects it cannot compare with platinotype. By using a paper with a suitable matt surface, however, much of this may be overcome. To secure the best effects, the negative must to some extent be of a special nature, and is not so suitable for printing in carbon or platinotype. Papers giving different contrasts and allowing considerable latitude are, however, now procurable. Perhaps the only really serious objection to the process is that some few experiments may have to be made to gauge the exact exposure; but this is one which will affect the novice chiefly, as a constant worker seldom has any difficulty in this direction. It is, nevertheless, probably the principal reason why amateurs in the past have not used bromide paper so much as they might have done. There are, of course, certain initial

difficulties which must be overcome by patience and perseverance; and, working with the widely different negatives which amateurs usually produce, the exposures are as complex even as those with plates. These difficulties, however, once overcome, the process will be found exceedingly easy, and what is more, regular and constant in its results both as regards tone and gradation.

PERMANENCY.

Undoubtedly the permanency of a developed print is vastly superior to one

twenty years ago, and which have been exposed during that time to a brilliant light, have not yet shown the slightest signs of fading or yellowing; which seems to suggest that the process is, for all practical purposes, permanent, and certainly proves that it does not deserve the stigma of lack of permanency, which seems so generally to have been bestowed upon it. It must be remembered, however, that thorough washing is necessary in all cases.

PREPARATION OF PAPER.

Of this very little need be said. Of the

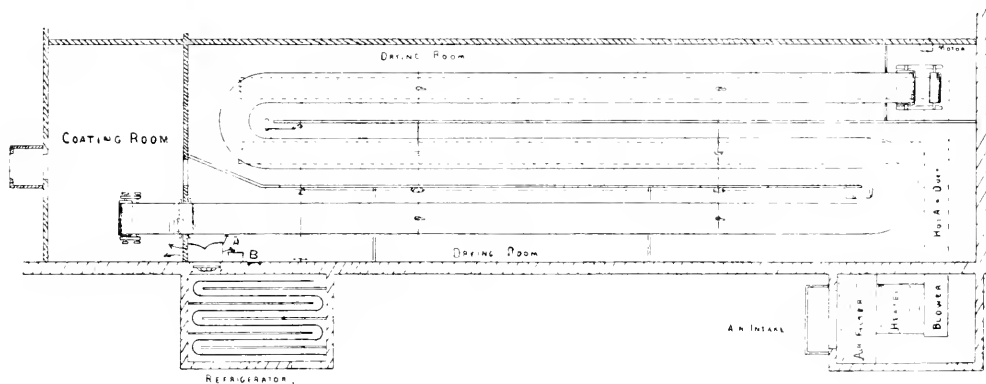

Fig. 308.—PLAN OF PAPER COATING ROOM.

printed out, while from a practical point of view the former may even be said to rival carbon or platinotype in this respect; for although the latter are, theoretically, more permanent—that is to say, platinum or carbon are more stable substances—yet prints by these processes are each liable to change. The platinotype will turn yellow, particularly if any appreciable amount of iron has been left in the paper; while, as already stated, the permanency of a carbon print depends solely upon the stability of colour of the pigment used. It may be said, then, that bromide prints, provided they are worked with extreme care, are more permanent than any other silver print, and possibly more so than an indifferent platinotype or carbon. Certain bromide prints made nearly

most experienced workers few have ever tried to make their own bromide paper, and a still smaller number have succeeded to their satisfaction. An emulsion is made up as described in the section on Plates and Films, and this is applied to the paper as directed in the section on "Printing-out Processes and Papers." As little information has hitherto been available, however, it will doubtless prove of great interest to all photographers to have a brief outline of the methods adopted in large factories for the production of such material.

A PHOTOGRAPHIC PAPER FACTORY.

Fig. 308 shows the actual plan used in the construction of one of the largest photo-

graphic factories in the world. It consists of a large building divided into two parts, both of which, although not absolutely dark, are illuminated only by a minimum of non-actinic light, so little as to leave not the slightest chance of fog during the brief period of exposure. As manufacture

paper in ten hours. Several exhaust air ducts may be provided, as shown in end elevation at *D*, Fig. 310. Slight modifications exist in certain cases arising from local conditions; but this description is sufficient to make the general principle understood.

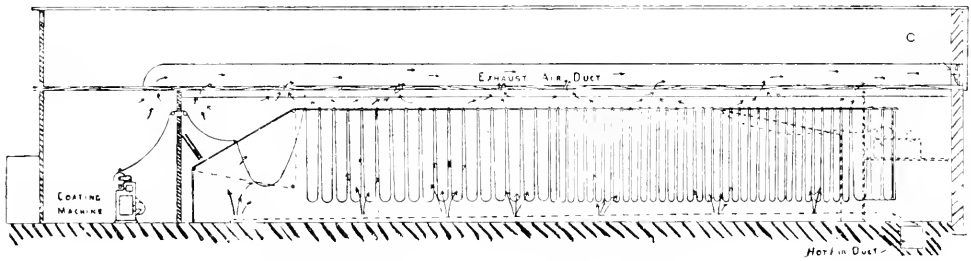

Fig. 309.—ELEVATION OF PAPER COATING ROOM.

under the latest conditions goes on almost automatically, the room may remain in complete darkness, except when it is necessary to ascertain that things are proceeding satisfactorily. The small room is the actual coating room, and contains the coating machine; the large room in which the paper is dried and reeled is divided into compartments, so that the temperature of the different parts may be under separate control. This division into compartments is absolutely necessary, for were it attempted to dry the paper straight away in warm air, it would simply melt and run. Cold air is first of all pumped in at *A*, by means of a motor *B*, after passing through a refrigerator. By this means, the emulsion is well set on the surface before reaching the hot-air chamber. The hot air passes into this room, as shown, at the air intake, and through a suitable heating apparatus; so that a stream of perfectly dry hot air is blown in at *C*, through a filter of cotton-wool to exclude all dust, and passed along pipes at *D*. Connecting these two pipes, perforated cross pipes are fixed at intervals, through which the hot air escapes upwards, and finds its way out through the exhaust air duct, which is controlled by a second fan at *C* (see elevation, Fig. 309). In this way it is possible to dry 9,000 ft. of

HOW THE PAPER IS COATED.

The method by which the paper is covered by a thin film of emulsion and rapidly carried away into the drying room will now be described. Fig. 311 represents the machine employed for this purpose. Very fine hard paper, coated with baryta,

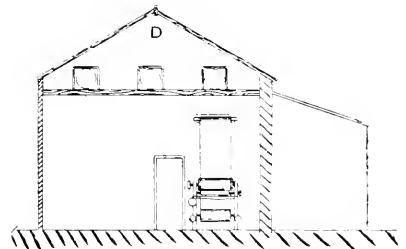

Fig. 310.—END ELEVATION OF PAPER COATING ROOM.

is used. The paper is placed upon a spool or reel at *A*, whence it passes under two small wheels (not shown), which put a slight drag upon the paper and keep it taut and even. It next passes between the two rollers *B* and *C*, up to the aperture in the coating room. The roller *B* is of nickel silver, and revolves in a silver pan, which rests in a hot-water jacket, kept so supplied that the emulsion always remains at the same temperature. The roller *C* is

filled with ice-water. The emulsion is poured into the pan, and the roller B revolves through it, picking up a certain

raising or lowering can be made to give a coating of any desired thickness. As the coating is applied, it is instantaneously set

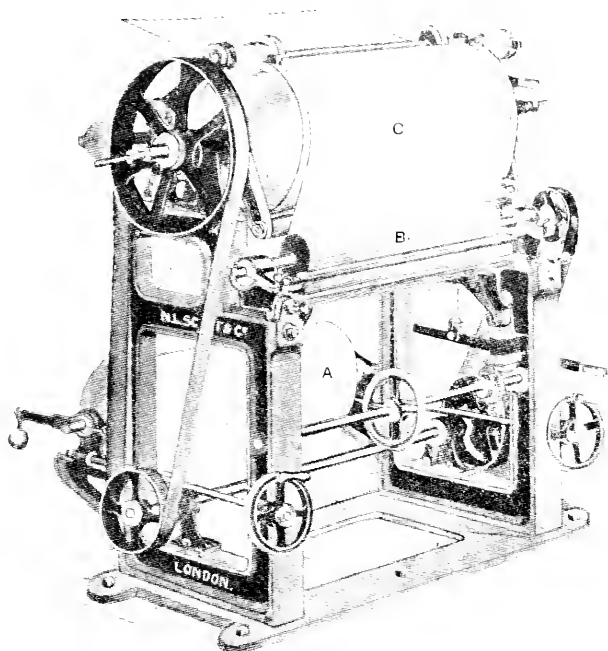

Fig. 311.—N. L. SCOTT & CO.'S MACHINE FOR COATING PAPER.

quantity on its surface and depositing it on the surface of the paper above as it passes along. The roller can be regulated

by means of the ice-water cylinder c, which is just a little longer each way than the roller B. The latter does not quite cover

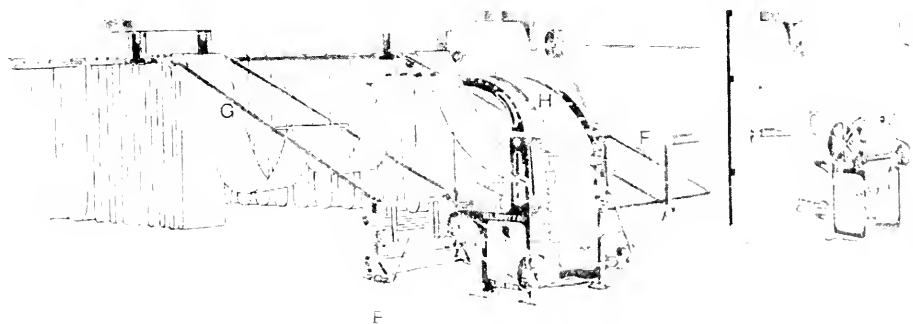

Fig. 312.—N. L. SCOTT & CO.'S PAPER COATING, DRYING, AND REELING APPARATUS.

with extreme nicety, so that it just brushes off the emulsion on to the paper, and by

the entire width of the paper; thus leaving a "safe-edge" on each side for the wheels

D D, which keep the paper firmly in position.

DRYING AND REELING THE PAPER.

The coated paper now passes into the drying room (see Fig. 312). The paper is automatically festooned by an ingenious arrangement of sticks travelling on chains. The sticks are shown at E, and travel across on to the inclined chains F, until they reach the horizontal supports, when

CUTTING THE PAPER.

The reel is now placed in this machine (Fig. 313) and cut into sheets. These fall on to travelling tapes, by means of which they are carried and stacked on a table. Guides are provided for preventing any curl. The machine makes from 50 to 60 cuts per minute, so that, as two or more spools can be fed through at the same time, it is capable of cutting the reels into

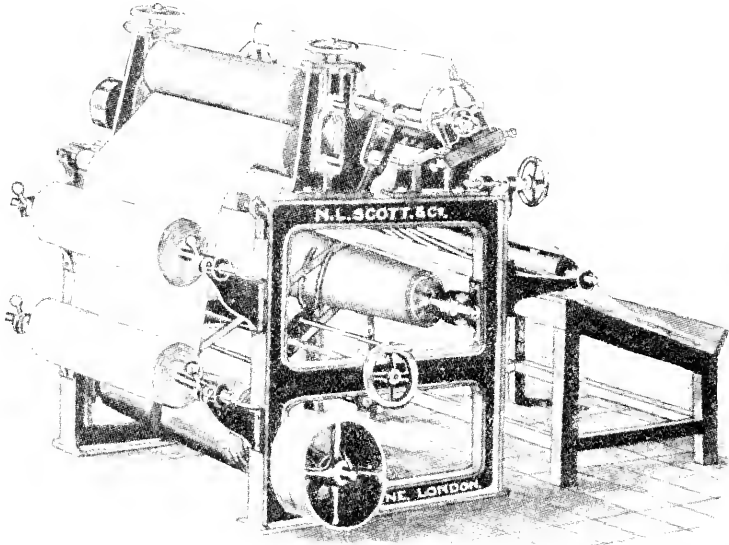

Fig. 313.—N. L. SCOTT & CO.'S ROTARY PAPER CUTTING MACHINE.

they travel along, up and down the room, as many times as may be desirable, being directed from one track to another by means of turntables. Ultimately the sticks reach a second inclined chain track G, when the sticks travel down and fall into the box E, ready to be once more transferred to the upward track. In this manner the festoon is slowly removed, the paper travelling under the curved guides H. It has by this time become perfectly dry, and exhibits a disposition to curl. The guides H remove this, assisted by wheels and rollers, which place tension upon it before it is slowly rewound on to the spool, whence it may be transferred to the cutting machine.

sheets 42 in. by 30 in. at the rate of 7,200 per hour.

PRESERVATION OF THE PAPER.

Gelatine is a substance somewhat liable to be affected by surrounding conditions; that is to say, it is liable to decomposition if stored in a moist atmosphere. This danger is increased if the air is warm, as will have been gathered from the previous remarks on gelatine. The air should be as pure as possible, and for this reason the paper should not be stored in proximity to volatile chemicals. Albumen paper, which as it becomes old gives off sulphuretted hydrogen, is liable to cause deterioration of a bromide paper if kept too near

it. The fumes of gas, oil, ammonia, etc., are all destructive, and the paper should, therefore, not be placed on a high shelf, neither should it be stored on the floor. (These remarks apply equally to other emulsion papers and plates also.) When the supply kept is small, and is quickly used up, such matters need not trouble the user; but workers abroad, and those who have to keep a quantity of paper in stock, will do well to give this serious attention. A suitable cupboard on a level with the body, will be very serviceable, if kept entirely for emulsion paper and plates. The paper is best when freshly prepared, as the tendency with emulsions is to become less sensitive after long keeping, thereby giving harder contrast. The best plan in dealing with an opened package of paper,

made use of, as the negative may be used straight away without waiting for it to dry, and even, in some cases, without waiting for it to fix. If the source of light is small, a very sharp shadow is cast, which means that it is not so essential that the paper and negative should be in absolute contact as when a diffused light like daylight is used. An experiment will illustrate this. Set up a focussing screen at A (Fig. 314) and a cross cut in cardboard B close to it, and at C place a lighted candle. Move B away from A say $\frac{1}{2}$ of an inch, and its outlines still remain clear although the shadow thrown is a little larger. Now place a sheet of ground glass in front of B so that the light passes through it, and

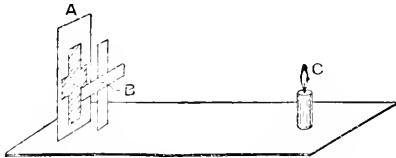

Fig. 314.—EXPERIMENT ILLUSTRATING SHADOW OUTLINES.

is to place it face down in a box—an ordinary dry plate box—and lay over it a sheet of stout plate glass, which by pressure excludes the air. Paper is usually packed in a proper condition for keeping when sent from the factory, so that it need not be interfered with. It is an advantage, under some circumstances, if the package is wrapped in waxed paper or tinfoil

PRINTING APPARATUS.

As the paper cannot be examined during printing, the choice of frames, broadly speaking, is very large; in fact, any kind of frame may be used. It is even possible to print a bromide without a frame at all; merely wetting the paper and squeegeeing it to the film of the negative. This is, of course, not a desirable plan in ordinary work; but when a print has to be made rapidly from a negative which has just been developed, it may be

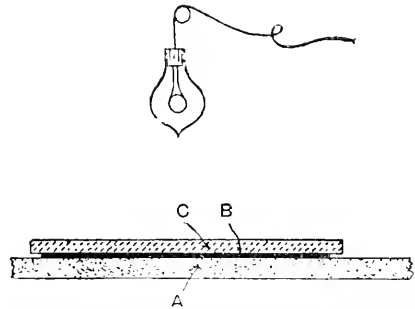

Fig. 315.—SIMPLEST ARRANGEMENT FOR BROMIDE PRINTING.

repeat the experiment, when it will be found that the outlines of the cross become indistinct directly it leaves the glass. Thus a very fair print may be made, as shown in Fig. 315. A sheet or two of blotting paper A is laid on a table, and over this, face up, the bromide paper B. Over the latter, again, with its film in contact with the paper, is placed the negative C. Such an arrangement necessitates the illuminant being arranged after the manner shown; if electric light is used this is fairly easily done. The method has its advantages where considerable "dodging" has to be done, as the various parts may be shielded by merely laying cards on the negative, but it is, of course, recommended only as a makeshift. The fewer the movements in the filling of the frame the better, as speed is a consideration. A suitable frame is shown in Figs. 316 and 317.

It is fitted with a back, which is set or removed instantaneously. It is also supplied with hinges on one side, and a turnbutton on the other, by which it may be adjusted over an opening in the dark-room door for exposure. Another arrangement (see Fig. 318) consists of a long board

numbers on one sheet when the pictures are smaller.

HOME-MADE DEVICES FOR RAPID PRINTING.

The amateur working on a small scale will find it sufficient to set up an ordinary

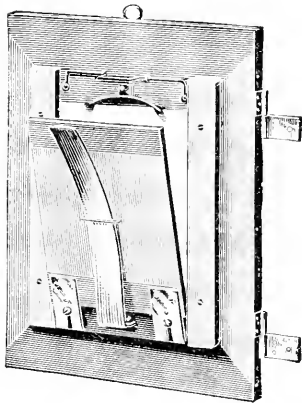

Fig. 316.—Back of Bromide Printing Frame.

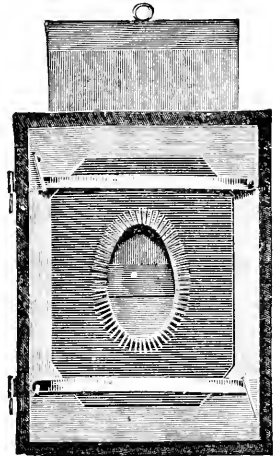

Fig. 317.—Front of Frame, showing Vignetter and Shutter.

with a central recessed opening to take the negative. Behind this travels a long strip of bromide paper, covered by a board, which may be moved along past the opening as much or as little as required, according to the size of the negative. A

gas jet, oil, or electric lamp at one end of a board or box, as in Fig. 321. If gas or electric light is employed, it is a good plan to fix the light in a clamp, as shown, since

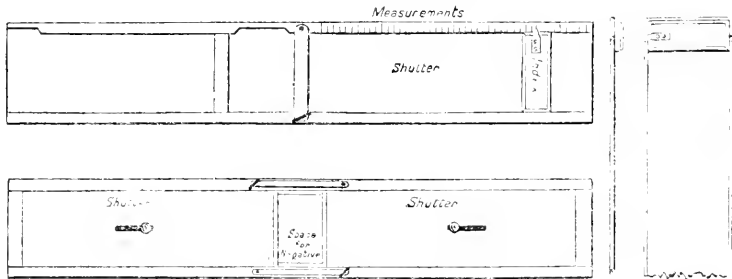

Fig. 318.—Frame for Lengths of Bromide Paper.

scale and pointer are provided on the board to ensure correct register. The apparatus may be used for rollable film also, and in either case the sensitive material can be developed in one piece. Another machine, recently placed on the market, is shown in Fig. 319. Fig. 320 shows a convenient plan for printing large

it may then be placed at any height, according to the size of the negative, thus ensuring an equal distribution of the light. This board should be marked off with a scale, and at certain distances, say 12 in., 18 in., and 24 in., from the gas jet, a wooden strip may be fastened across, so that the exact distance may be easily

found in the dim light. For working on a larger scale, the apparatus shown in Fig. 322 may be used. This consists of a wooden box A, screwed firmly in the centre of a steady table, within which is an

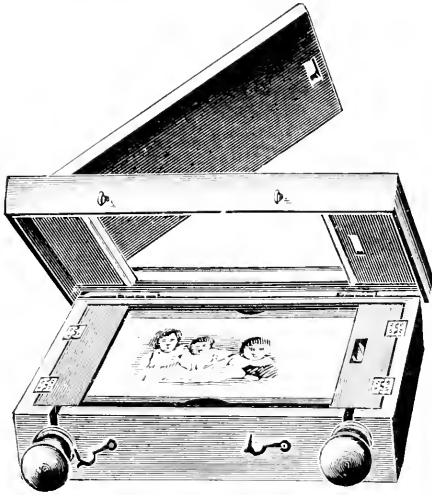

Fig. 319.—BROMIDE PRINTING MACHINE.

S c.p. electric lamp B. (A paraffin lamp or gas jet might be used if a suitable top were provided.) The box measures 3 ft.

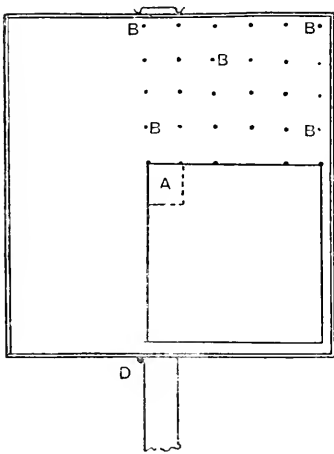

Fig. 320.—ARRANGEMENT FOR MULTIPLE PRINTING.

square, so that either side is 18 in. from the lamp. It has four windows, c, each of which is provided with a frame d grooved to take a shutter e of canary fabric.

To each of these four frames is hinged a printing frame F—ordinary frames may be used—the back of which does not fasten in with the usual springs, but is hinged in the same way as a camera focussing screen to the bottom, and folds over the

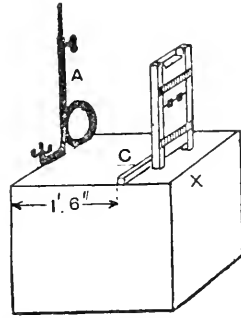

Fig. 321.—HOME-MADE DEVICE FOR RAPID PRINTING.

paper, being held firm by a brass spring at top. In this way four printers may work at the same light, and produce a large number of prints in an incredibly short space of time. The light remains the same throughout, being toned down

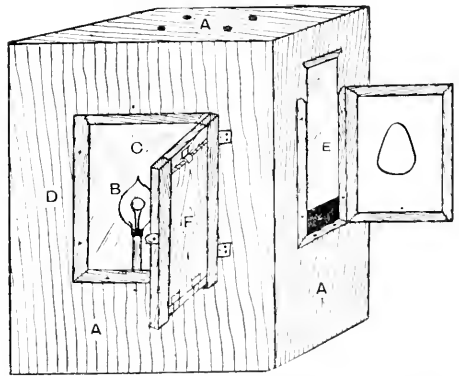

Fig. 322.—ARRANGEMENT FOR WORKING SEVERAL FRAMES TOGETHER.

if too bright by several thicknesses of tissue paper placed over the front of the frame. The exposure is made by drawing the canary shutter. If the first named apparatus is used, the lamp should be provided, if possible, with a by-pass, to avoid constant relighting, and there should be another lamp in the room. A yellow

light is preferable to a red one for working in, as regards development, since the contrasts and tone of the picture can be better judged. There should be plenty of light in the dark-room. If of the proper colour it is surprising how much may be used. Breakages will thus be avoided. For dishes, the wooden ones with glass bottoms are cheap and seem to answer well, but it is advisable to have the glass fairly thick at bottom or they are very liable to breakage. The common window glass put into them usually is altogether insufficient.

THE NEGATIVE.

The best prints are produced from soft, crisp negatives, fully exposed, with clean shadows. Negatives that are fogged and flat from over-exposure are not satisfactory, although much may be done even with these by suitable exposure on suitable paper. Satisfactory negatives should, as far as possible, be used in gaining experience with the process. The worst type of negatives for any kind of paper, and those with which it is almost impossible to produce satisfactory prints, are negatives which are under-exposed and over-developed. In these the high lights are dense, and the gradations of the lighter parts—usually the most pleasing part of a bromide print—are lost; and notwithstanding all the care that may be taken, a hard unpleasing contrast will probably result.

ILLUMINANTS.—THE CANDLE.

The choice of illuminants for the purpose of exposing the paper has already been referred to. These vary from the modest candle to elaborate electrical arrangements. The candle need not be despised for small work, such as quarter-plate and 5 in. by 4 in., as it is fairly constant in power and conveniently arranged. It necessitates, however, the frame being placed rather near to it, which is not always advisable. Generally speaking, the frame should be at a distance equal to the diagonal of the plate illuminated; but in certain cases, where the negative is too

thin at the margins—due to the unequal illumination given by the lens—it may with advantage be placed much nearer. The exposures with it are also necessarily long. Still, cases are fairly common when a candle has been successfully used, both for exposing and dark-room lighting, by simply making a tube of canary medium and slipping this over the candle.

OIL LAMPS

have the advantage of convenience in some instances, being everywhere obtainable; but if used, considerable care should be bestowed upon them. The disagreeable odour issuing from them, when improperly attended to, is unpleasant enough in itself; but there is a still greater danger of these fumes causing deterioration of the paper. This is, perhaps, of no importance to the small worker, but it is considerably so where a quantity of paper is kept. See, therefore, that the lamp is well cleansed, a good practice being to soak the burner occasionally in hot soap and water. No charred pieces of wick should be allowed to find their way over the draught holes. These remarks apply equally to other cases where oil lamps are used. It is essential that the light should be kept as constant as possible, and to ensure this the wick must receive proper attention. It is preferable to rub away the charred portions of wick with a piece of paper, rather than to cut them with a pair of scissors, as the latter generally results in an uneven edge, with consequent loss of light. It is, perhaps, hardly necessary to point out that the quality of the oil materially affects the nature of the light. The latter is considerably more actinic, besides being visually more brilliant, when it is produced by the better class of oil. Moreover, the combustion products are greater in the case of the cheaper kind. Some workers recommend the addition of a little camphor to the oil, as giving a white light, which it certainly seems to do. One decided disadvantage of this illuminant is the amount of heat given out; which, when the negative has to be placed

near to it, is liable to crack the latter. When a reflector is used behind an oil lamp, it should not be of such curva-

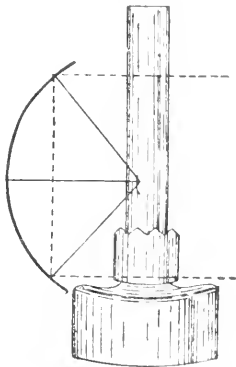

Fig. 323. - RAYS FOCUSED ON SOURCE OF LIGHT.

ture or in such position as to refocus the rays on their source—a state of things always aimed at with other illuminants (see Fig. 323), but should let them issue more widely. (See Fig. 324 and compare with previous figure.)

GAS LIGHT.

Of the ordinary gas light nothing need be said beyond the fact that a fair sized jet should be used. The "Economiser" burner for slipping over the ordinary jet is an

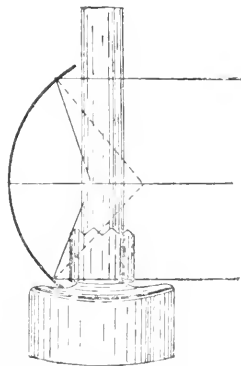

Fig. 324. - RAYS REFLECTED APPROXIMATELY PARALLEL.

improvement. The reason for preferring a large flame is that the larger the source of light, in proportion to the negative, the softer will be the effects. This refers more particularly to vignetting, and to such

cases where "dodging" has to be done on the back.

ELECTRIC LIGHT.

Certainly the most convenient light is the electric incandescent, which has no

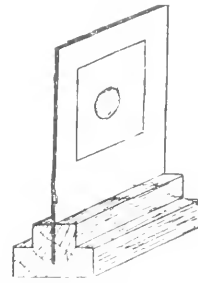

Fig. 325. - CONSTRUCTION OF PHOTOMETER.

objectionable products of combustion, is readily fixed in any position, and is so easily turned on and off. Either an eight or a sixteen candle power lamp is suitable. The colour of the light is not of so much importance, as this merely affects the length of exposure.

DAYLIGHT

is seldom used nowadays for this work, being far too brilliant. It is, however, sometimes employed for the slower chloride papers and for what are now called "gas light" papers; but even for these, artificial light, being more constant, is certainly preferable. Whichever illuminant is chosen, the first thing to do is to form some rough estimate of its power, which is usually spoken of as so many "candles."

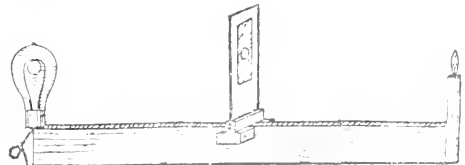

Fig. 326. - PHOTOMETER FOR TESTING LIGHT.

MEASURING STRENGTH OF LIGHT.

If it is necessary to work with different lights, their proportionate values should be found by the photometer. This is really

a very simple process. Cut a square hole in a sheet of card, say 12 in. by 10 in., and fasten over it a piece of white paper, in the centre of which a spot of oil has been dropped. Fasten this to a block of wood, as shown in Fig. 325. Place this opposite the source of light to be used, and in a straight line with both put a candle (see Fig. 326). On looking at the card it will be noticed that on the side nearer the stronger light the paper appears white with a black spot, but on the other side it will appear dark with a light spot. Now move the card along, keeping the lights still, until the spot appears to be equal on both the sides. Measure the distance of each light from the card. Say the distance from the candle to the card is 4 in., and the distance from the stronger light to the card is 32 in. If these two figures are squared, the result will show the relative intensities of the two lights, which is thus 16 : 1024, or 1 : 64. In using any other illuminant, the same operation must be gone through with the same candle. The colour of the light, however, must also be taken into consideration. The electric incandescent and the gas incandescent would show considerable difference in results even when accurately matched in other respects.

REDUCING THE EFFECT OF ACTINIC LIGHT.

The actinic value of the light of a room is best reduced by removing farther from the window, although, if the window is large and the room small, the power of modification in this respect will be exceedingly limited. A better conception of the matter will probably result if the reader thinks of the room as a camera, and the window as the aperture in the lens, when, provided the area illuminated is larger than the source of illumination, the law of inverse squares practically holds good, and the intensity of the light is inversely as the square of the distance; although theoretically this is only correct when the source of light is a point, and not when parallel rays are concerned. The relative actinic of the light of a room may be measured by means of the exposure meter described in the section on Exposure of

the Photographic Plate, and it is an interesting experiment to do so at different distances from the window. Except with mechanical devices, the exposure should range from two to ten seconds, as such may be made with greater accuracy.

CUTTING THE PAPER.

This operation, as far as possible, is just as well left to the manufacturer, as there is no difference in price, and it can be obtained in almost any size. When it is necessary to cut the paper, it should be folded and divided with a paper-knife, or cut with a pair of scissors. Such work necessitates handling the paper, and care should be taken to touch or scratch the film as little as possible. Bromide emulsion is not nearly so sensitive as chloride emulsion to perspiration or finger marks, yet it seems to be far more affected by some fingers than others. It is best, therefore, to be on the safe side, and touch it as little as possible. The emulsion is, however, very sensitive to pressure. This is more apparent in some brands than others. With some makes, the mere stroking on the back with the paper knife causes a mark. With one make experimented with, a light pencil mark on the back of the paper caused a deep line on the face of the print. The experiment is an interesting one. Lay a sheet of bromide paper face down on a clean sheet of glass, and on the back press heavily a silver coin. An image of the coin can frequently be produced. Or, write on the back with the point of a bone knitting needle and you may obtain a similar result. This seems to suggest that cutting the paper with shears is preferable.

RIGHT SIDE OF PAPER.

It is not necessary to say that the right side of the paper is the coated side; yet to distinguish this side presents some difficulties to the novice. It is really, however, quite easy. The paper is usually sent out from the factory packed all one way, except the bottom piece, so that if the right side of one is found the remainder can easily be distinguished. Draw out a sheet of paper from the box and note

which way it curls. The side which curls inwards is the sensitive side. If it is such stout paper that it shows no signs of curling, then breathe gently on it and leave it for a moment. A further test consists of applying the tongue to one corner, when the gelatine side may be distinguished by its tackiness.

THE EXPOSURE.

The best results are obtained by keeping to one source of light only. The intensity of light varies inversely as the square of the distance, therefore if the distance from the source of light be doubled, the exposure duration must be quadrupled. Hence, to obtain evenly printed proofs from the same negative, its distance from the light must be exactly the same at each exposure. The nearer the negative to the light the more important this becomes. Thus one edge of a negative may receive a much greater exposure by tilting towards the light, and this is a method often resorted to where the density of the negative for certain reasons is unequal. The factors which govern exposure may be summed up as follows:—(a) The intensity and colour of light; (b) the distance from the source of light to the frame; (c) the position of the frame; (d) the colour of the negative; (e) the contrast of the negative; (f) the density of the negative; (g) the rapidity of the paper; (h) the kind of developer used; and (i) the depth, colour, and contrast or gradation desired in the print. This at first seems formidable, but some of the factors may be eliminated. Thus, by using always the same light and distance, the first two disappear, whilst until some considerable experience has been obtained, it is well to keep to one make and speed of paper, and one developer, thus eliminating (g) and (h). That the negative should be free from yellow stain is especially necessary in this process, for as the light-obstructing power of the negative has usually to be gauged in artificial light, different degrees of yellowness, which make so much difference to exposure, will pass unnoticed. To remove yellowness, pass the negative before it dries through a 5 per cent. solution of

hydrochloric acid. Of the remaining points (c) is connected closely with (i)—that is, if a weak effect is desired from a strong negative, it is possible to obtain it by under-exposing, and (c) will come into play on rare occasions, so that only the density of the negative and the depth of printing need be considered in first attempts. The best method of finding the exposure is to try a strip of paper on the negative in three sections. The makers of every brand of paper issue a rough guide with their instructions, such as "Exposure for average negative, 10 sec. at 18 in. from ordinary fish-tail burner." This is intended as the roughest guide only, for, as most amateurs' negatives are either too dense or too thin, it is seldom correct. An excellent device for testing the density of any negative, and ascertaining the relative exposure as compared with other negatives, is now obtainable. It is known as Dawson's Densitometer, and full directions are supplied with the apparatus.

RELATIVE EXPOSURES AT DIFFERENT DISTANCES.

The factor (a) will have been settled by testing it photometrically, as described earlier (p. 221), whilst factor (b) should by the same experiment be rendered fairly clear. For convenience in readily estimating the proportionate exposure required at different distances without calculation, the subjoined table is given. The most usual distance is about 18 in., but any other distance may be employed to keep the exposure within proper limits.

DISTANCE.	TIME OF EXPOSURE IN SECONDS.									
	1	2	3	4	5	6	7	8	9	10
6 in.	1	2	3	4	5	6	7	8	9	10
9 in.	24	4½	6	9	11	13½	15½	18	19½	22½
12 in.	4	8	12	16	20	24	28	32	36	40
15 in.	6	12	18	24	30	36	42	48	54	60
18 in.	9	18	27	36	45	54	63	72	81	90
24 in.	16	32	48	64	80	96	112	128	144	160

To use the above table, the exposure must be ascertained at the given distance, say 18 in. Suppose this to be 72 seconds. The table at once indicates how much nearer the light the frame must be placed to bring the exposure within more reasonable limits. On a large run, this method

will save a considerable amount of time. For example, at 6 in. it will only require an exposure of eight seconds. It may happen, however, that this is too near the light to give even illumination, for the frame should never be placed at a distance less than the diagonal of the negative being printed from.

DURATION OF EXPOSURE.

A print from an average negative, upon Elliott's Platino-Matt bromide paper, which is a very suitable one for a beginner, should have an exposure of about six seconds; using a No. 5 Bray's gas burner.

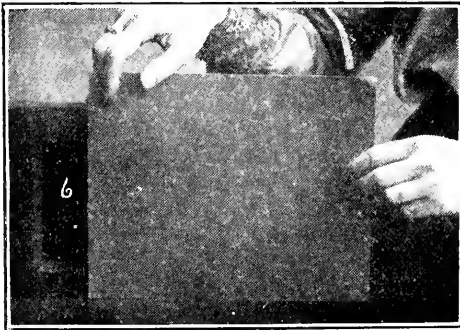

Fig. 327.—SECTIONAL EXPOSURE.

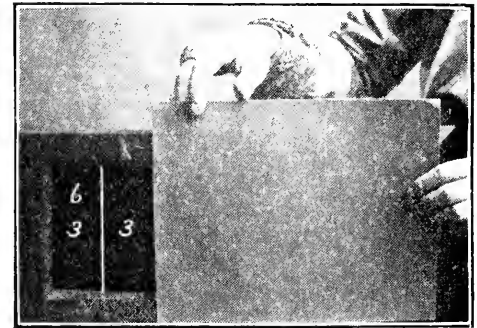

Fig. 328.—SECTIONAL EXPOSURE.

This is merely intended as a rough guide; the exact exposure being only found by experiment. The best plan is to make an exposure in three sections, behind the negative, giving each one twice the exposure of the preceding one; or assuming first an exposure as correct, and giving that to the centre portion, with half that and double that to the outside parts. This may be effected without any special frame, by just covering up parts of the negative with a card, and giving the assumed exposure to the first third, half this to the second third, and the same to the last third. For example, suppose a negative is to be tested; fill in paper and cover up two-thirds, as in Fig. 328. Now assume any exposure to be correct, say six seconds. Give this exposure, then turn off the light or shut off with shutter, and move the card, as shown in Fig. 329, giving half the assumed exposure, or three seconds; then shut off light once more,

remove card, and give three seconds again. Then the first part will have had $6 + 3 + 3$ or twelve seconds, the second $3 + 3$ or six, and the last three seconds. It frequently happens that the frame will have to be covered with tissue paper to diffuse the light. This must always be done when there is to be dodging or vignetting. It has been found that ordinary tissue paper only allows one-third the amount of light to pass therefrom. If the exposure for a plain negative is known, the exposure for a vignette for same will, on account of its being covered with tissue paper, therefore be three times as much.

DEVICES FOR TIMING EXPOSURE.

For short exposures the printer can easily count, and a little practice enables one to do this quite accurately. The novice should learn to count seconds, against a stop watch or seconds hand watch. Start counting with the hand on sixty, and without looking at the watch count up to sixty again and stop the watch. This will tell you at once whether you are contracting a habit of counting too slowly or quickly. Short exposures are better counted than timed by a watch, but a pendulum may be used. A metronome (Fig. 329) as used for beating time in music can be employed, or a very simple arrangement is shown in Fig. 330. It consists merely of a weight A on a length of rod B connected to a lead block C by a piece of clock spring, and as it swings causes the catch E to vibrate and sound the seconds. Counting is a little tedious, and an electric alarm is



1. UNDER-EXPOSED



2. CORRECTLY EXPOSED



3. OVER-EXPOSED.

EXAMPLES OF BROMIDE PRINTING

used by some workers. This is an advantage with long exposures, as the printer may proceed with other work. For example, suppose gaslight papers are being used, the frames may be arranged on a board, so as to illuminate, say, a dozen at one time. The exposures of half of these may be five minutes, another six, two more seven and a half minutes, and so on. The alarm is fixed for five minutes, then for one minute, then for one and a half minutes, and so on. As the bell rings, the frames are turned down, and may be filled in as convenient.

SENSITIVENESS OF PAPER.

Bromide paper is usually made in two speeds, slow and rapid. The latter is

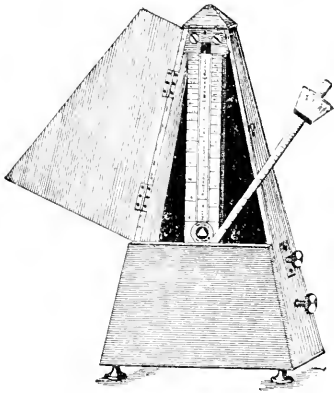

Fig. 329.—METRONOME.

chiefly used for enlarging, and the former for contact printing. Both may be used for either process with advantage, as the rapidity of the paper greatly influences the character of the result. For example, the blacks of the rapid paper never reach such a deep tint as they do with the slow paper, and therefore the results are softer. So that, when printing from a hard negative, it is preferable to use rapid paper; and when printing from a soft negative, or one inclined to flatness, the slow. A specially slow make of paper is supplied by some firms, for very hard effects. This, as already pointed out, is one of the advantages of the process; as ranging from Carbon Velox to Kodak Rapid are

a number of different papers, which give almost any desired contrast.

METHOD OF EXPOSURE.

In taking up a fresh negative, a test should be made either with a strip of paper or in sections as described. The results of these tests are compared, and if necessary, further ones made until successful. The exposure is then written on a thin strip of paper gummed to the edge of the negative for the purpose, giving particulars as to time, distance, and paper, assuming the light to remain constant. Thus a negative requiring six seconds at 18 in. on rapid paper is marked 6—18—R. Of course, these tests must be developed as taken, but once the exposure is settled, the papers may go into a box and wait

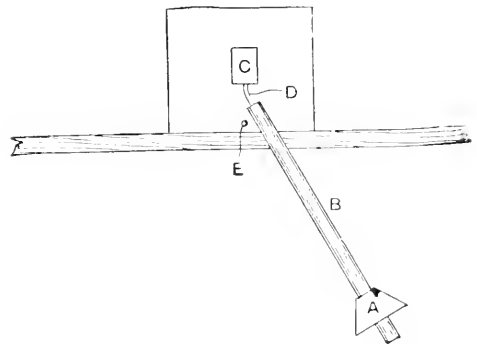

Fig. 330.—APPARATUS FOR TIMING EXPOSURE.

to be developed together. With regard to the number of prints, some workers mark each on the back as done, so as to avoid printing more than necessary; but this practice is bad for the reason before stated. The best plan is to lay them all one way in the box and keep count; those from the next negative being laid the reverse way, and so on. Or the required number of sheets may be counted out before commencing. Supposing the printer to be using the exposure box previously described, the back of frame is removed, and the paper placed in position. The latter should not be cut an exact size, but should be larger than required, to allow of trimming afterwards. The back is filled in, and the shutter drawn: these

operations only taking a few seconds. During the whole time, the paper may be left exposed in the room without fear. There is, however, one disadvantage in the use of this box. It sometimes happens that a negative is denser one side than the other, and needs to be shaded gradually across. When working on a board, this may easily be done by slanting the frame so that one side comes nearer the light; but with a box any necessary dodging must be done by covering up. Such negatives, however, are not common, and may be exposed differently from the general method.

INFLUENCE OF STRENGTH OF LIGHT ON CONTRAST.

There can be no doubt that by using lights of different strengths the contrasts, and therefore the gradations, of a print may

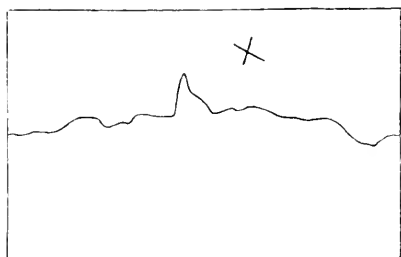

Fig. 331.—PRINTING-IN CLOUDS.

be modified. This can be effected in two ways: (1), by varying the distance from the light, and (2) by altering the strength of the light. When working on the board the first method is employed, and with the box the second. In varying the intensity of light, this should not be done by turning it up and down, but by interposing tissue paper between it and the negative. If, for example, the negative is harsh, it should as far as possible be printed with clear glass. If, on the other hand, a negative is weak in contrast, with the shadows clogged by over exposure, then by printing through tissue paper the contrasts may be greatly strengthened. At the same time, however, it must be borne in mind that this softens the outline (see page 217), and that as a consequence the contrasts are not so great

as when printed by a weaker light, the source of which is small. As a rule, however, such effects are not desirable, unless the image in addition to being flat is not very sharp also.

DODGING.

This is done in the same way as described in the section on Preparation of the Negative for Printing, except that the shade card must be cut out and attached to the frame with drawing-pins. This is then covered with tissue paper, and exposed (the extra exposure required by certain parts having been estimated) for the necessary time. The masking is then removed, and the negative again exposed.

SKY AND COMBINATION PRINTING.

To do this, cover that part of the negative where the new matter is to be intro-

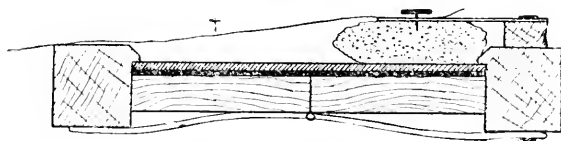

Fig. 332.—USE OF COTTON-WOOL IN SKY PRINTING.

duced, and expose as above. Then open the frame, and mark the back of the print in outline (see Fig. 331), putting a cross on the part not printed. Now lay down, in a larger frame, the sky negative, or that with the new figure, and mask all except that which is to print carefully from the front. This must be done not with sharp outlines, but with a vignetted effect, by means of cotton-wool, as shown in Fig. 332. The paper is now fitted over, and the second exposure made. It will be understood that each time the frame is covered with tissue paper *T*. A frame several sizes larger than the negative should be used for printing in skies, and, if this is not possible, the plan suggested on p. 161 must be adopted; or if using the box and electric light it can be very conveniently done on

the top. For further information on combination printing, see the section on Preparation of the Negative for Printing.

VIGNETTING.

This is a much simpler operation. The frame is fitted up as described in the previously mentioned section, covered with tissue paper, and exposed as usual. It has been recommended that the vignette should be kept on the move. This is a most unsatisfactory plan, and never used by those who do the work commercially. Neither is there any advantage in moving the frame during exposure, as is sometimes done by novices. If the tissue paper front is used, and the negative has a proper background, it cannot practically affect the result. The vignette should always be fixed on the front of the frame, and on no account should vignetting glasses and such devices be used for bromide work. The "adjustable" vignettes are not open to quite the same objections, but there is no better way than to cut each vignette from a sheet of cardboard. Be careful not to forget the use of the wool for softening the shadow, and remember always that the vignette will spread most towards the thinner part.

VIGNETTING-MASKS.

It is almost impossible to vignette successfully a picture having a dark background. If for some reason the corners of such a picture must not be printed, the negative should be covered with a medalion or cushion mask as used with lantern slides. Such masks may be purchased, but occasions arise when the exact size is not obtainable; then the mask may be cut from black plate wrapping paper with one half of a sharp compass pen, or a wheel print cutter with a universal joint.

METHOD OF VIGNETTING.

To vignette a picture in a card that completely covers the inner edges of the projecting front part of the frame, cut a hole somewhat smaller than the portion it is

desired to print. This allows the light to spread as shown by Fig. 333; where A is an opening in a card B, which, being placed on the edges of the frame C, leaves a space of about $\frac{1}{2}$ in. between it and the negative D. E is the cover glass, and the dotted lines G show how the light is still further spread by reflection. The vignette should never follow closely the outline of the figure, and the conventional egg-shaped opening should as far as possible be avoided. The printer's taste must, however, be the guide. To cut the vignette, mark it out roughly on the card rather smaller than is thought necessary for the opening; it can be broken out larger as required. There is no advantage in serrating the edges, although some workers

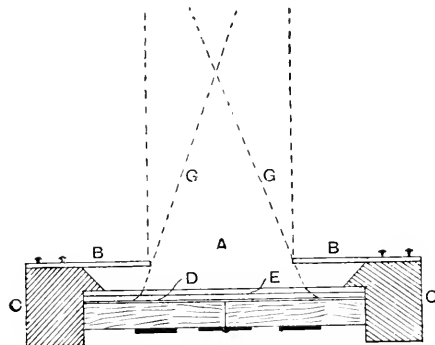

Fig. 333.—METHOD OF VIGNETTING.

scallop them, and of the two this is to be preferred. Unless the negative is dense, when the image cannot be seen from the front the paper should first be filled in as before and the back fastened up. Lay it flat and adjust the vignette in position, cover the opening with a sheet of ordinary white tissue paper, and fasten with drawing pins through it into the frame. In arranging the vignette, a portion of the bust is necessary, but the waist should seldom or never be allowed to show. As the waist is generally a thin part of the negative, the card vignette will not suffice to stop it out, for the diminished light will still have effect. A piece of cotton-wool should generally be placed below the part marked B, the edges being fluffed out. A general rule for vignetting is to place the opening

nearer the denser part of the negative. With the opening in the centre the picture will print more towards the shadow parts and appear one-sided. Another common error is to place the vignetting card too near the negative. As the light has to pass through tissue paper the exposure must be increased in the proportion of 1 to 3.

DEVELOPMENT.

The formulæ for this purpose are numerous. Until ten years ago, the ferrous oxalate developer was almost entirely used, and there are still some who prefer it. A formula which may be recommended is given on p. 229. It has the advantage of giving exceedingly good blacks, and an old solution gives striking contrast. Generally speaking, nowadays, metol-hydroquinone is employed. The best formula for this is: (No. 1)—Metol, 100 grs. ; hydroquinone, 50 grs. ; sulphite of soda, 2 oz. ; water, 40 oz. (No. 2)—Soda carbonate, 4 oz. ; water, 40 oz. (No. 3)—Potassium bromide, 1 oz. ; water, 10 oz. For use take 4 parts No. 1, 1 part No. 2, and 6 drops to each ounce of No. 3. The metol should be dissolved first in half the quantity of water made warm, and the sulphite then added, dissolved in the other half. Finally, the hydroquinone is put in, and the solution well shaken. This developer will keep for a considerable time, even after mixing with the carbonate solution, and may be used repeatedly. When it slows down it should be thrown away, as otherwise the prints will be brown and weak. A little fresh developer may, each time, be added to the old solution, and the sediment poured away.

ALTERNATIVE DEVELOPING SOLUTIONS.

Roughly speaking, any of the developing formulæ used for plates may also be employed for paper, but pyrogallie acid must be excluded from the list, owing to its tendency to give a brown image. Any of the newer developers, or "non-staining" developers, are suitable, as also is ferrous oxalate. Even with these a stained image is possible if development is too pro-

longed. The developer must be moderately active and not too restrained.

HYDROQUINONE.

This may be made up as a one- or two-solution developer. It may be used with the carbonates of soda or potash, or the hydrates of soda or potash. Soda hydrate, owing to its greater strength, is more suitable, as it tends to counteract the somewhat hard effect produced when hydroquinone is used alone. Potassium metabisulphite may be used as a restrainer as well as a preservative. Acids, such as citric and acetic acid, also restrain; but the bromide of potassium is more frequently used as a restrainer and sodium sulphite as a preservative. The sulphite should be dissolved in water before adding the hydroquinone. The following is a two-solution developer: (No. 1)—Hydroquinone, 100 grs. ; soda sulphite, 2 oz. ; water, 20 oz. (No. 2)—Soda hydrate, 120 grs. ; water, 20 oz. For use, take equal parts of No. 1 and No. 2 and add 8 drops per ounce of a 10 per cent. solution of potassium bromide. If it is desired to keep the developer in one stock solution, the following may be made up: Hydroquinone, 160 grs. ; potassium metabisulphite, 100 grs. ; carbonate of soda, 2 oz. ; water, 10 oz. Dissolve the soda separately, and then mix. For use, take 1 part of solution with 10 parts of water.

METOL.

Used alone, this gives soft prints inclining to greyness in shadows. The results are not so good as when used in conjunction with hydroquinone, which tends to greater contrast and better gradation. The carbonates of soda and potash may be used as accelerators and the bromide as a restrainer. Caustic alkalies are too energetic. A good two-solution developer is: (No. 1)—Metol, 140 grs. ; soda sulphite, 2 oz. ; water, 30 oz. (No. 2)—Carbonate of soda, 2 oz. ; water, 10 oz. For use, take 3 parts of No. 1 to 1 part of No. 2, and dilute with an equal bulk of water; then add 10 drops of a 10 per cent. solution of potassium bromide. A good one-solution developer is: Metol, 80 grs. ; soda sulphite,

2 oz. ; carbonate of potash, 1 oz. ; potassium bromide, 12 grs. ; water, 10 oz.

FERROUS OXALATE.

This developer is still recommended for bromide paper. It gives good blacks, but there is danger of staining if it is carelessly used. Novices do not usually succeed with it. It has the further disadvantage that the iron must be dissolved out, and the acid removed, before fixing, or fading will result. No. 1: Potassium oxalate, 4 oz. ; water, 10 oz. No. 2: Ferrous sulphate, 5 oz. ; water, 10 oz. ; acetic acid, 10 drops. For use, take 6 parts of No. 1 and 1 part of No. 2, and add 4 drops of a 10 per cent. solution of potassium bromide. In mixing these, it is essential that the ferrous sulphate should be poured into the oxalate, not the oxalate into the iron. The reason for this is that when ferrous sulphate mixes with potassium oxalate there is formed ferrous oxalate, a yellowish insoluble compound—which, however, is soluble in excess of potassium oxalate. Thus, if the oxalate is poured into the iron, the result is a dirty yellow mud, whilst if the iron is poured into the oxalate a clear red solution is formed, as the potassium oxalate is all the time in excess of the iron. The prints must be placed direct from the developer in a bath of acetic acid (or citric or sulphuric acid may be used), strength 1 in 200. The developer may be used repeatedly, but gives harder results as it becomes old. It may be reconverted to its original state by standing it in the sun, the ferric oxalate being thus changed once more into ferrous oxalate. Another developer is: Glycin, 10 parts ; sulphite of soda, 30 parts ; carbonate of potash, 56 parts ; water, 750 parts.

AMIDOL.

Another favourite developer among some workers. It gives results very similar to metol, and may be used quite fearlessly even by those whose skins are affected by the action of metol. The peculiarity of this developer is that it does not need the assistance of an alkali to reduce the silver. The simplest method of using this is to take any desired quantity of the 10 per

cent. solution of soda sulphite already made up for ordinary plate development, and to add 3 grs. of amidol and 1 grain of potassium bromide to each ounce. Potassium bromide is not capable of restraining to the same extent as usual with this developer.

EIKONOGEN.

This developer is now little used for bromide work ; the following is a simple formula for use as a single solution : Eikonogen, 60 grs. ; soda sulphite, 1 oz. ; carbonate of soda, $\frac{1}{2}$ oz. ; water, 10 oz. For use, dilute with an equal bulk of water. There are many other developing or reducing agents which may be employed, such as ortol, synthol, adurol, rodinal, kachin, etc., but the points of difference are so few as to render separate description unnecessary.

WHEN TO STOP DEVELOPMENT.

Bromide prints must not be developed in the same manner as negatives, which are merely a means to an end. Generally speaking, the time to stop development is when the deepest shadows just begin to veil. If a bromide print is properly exposed, it will hardly over-develop. That is to say a few seconds longer in the bath will not affect it. Development must be stopped directly the detail commences to show in the highest lights ; remembering that the print will be somewhat darker when dry. More exact instructions cannot be given ; these matters depend so much on individual taste, which is best formed by experience.

TIME OF DEVELOPMENT.

This influences the result, both as regards colour and contrast. When development is slow, the contrasts are weak and the colour inclines towards brown. When development is rapid, the colour is blue-black or black and contrasts are strong. The aim should always be to have the development as rapid as possible, whilst still under control. Bear in mind that a freshly prepared developer always possesses greater strength than one made some time before, particularly if the latter has been

used. Also that during development the solution is constantly getting weaker, and the smaller the quantity of solution used the more apparent this becomes. Further, that this alteration is the more noticeable the greater the area of solution which is presented to the air, as it is the more readily oxidised. For this reason, a developer which keeps well is a great boon, as its alteration is reduced to a minimum. Modifications may be made with a view to altering contrast, but cannot be recommended, except in extreme cases. Generally speaking, all such effects should be produced by judicious exposure and dodging. Fresh developer may, however,

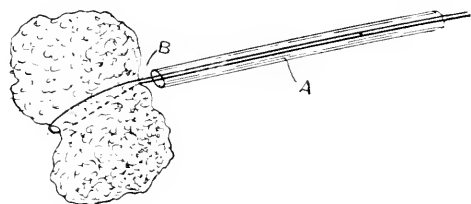

Fig. 334.—BUCKLE BRUSH.

be added to the old, if found to be working too slowly. Local development is seldom advisable with small bromide prints. With larger prints and enlargements, however, local treatment is a good deal employed. The method just referred to is called brush development. The developer is first applied to the wet print with a mop or Buckle brush (see Fig. 334) on the parts requiring most development. This consists of a piece of glass tubing A, through which is threaded a loop of white thread B, which will hold a tuft of wool lightly to the end when pulled taut. The thread is tied round the end as shown.

TEMPERATURE.

The influence of temperature on development is considerable, and exercises the same effect as strong and weak solutions both in colour and contrast: the former corresponding with a high temperature, and the latter with a low one. As far as possible, a temperature of 60° F. should

be maintained. A higher temperature risks the chance of causing blisters or even of dissolving the gelatine. The addition of hypo. to the bath causes a result similar to the use of an excess of accelerator. For further information on this point, and on fog and development generally, see the section on the Chemistry of Development.

METHOD OF DEVELOPMENT.

At least three dishes are necessary, exclusive of the hypo. baths. These should be arranged as in Fig. 335 for systematic working. The one on the extreme left is filled with water, the next is for the

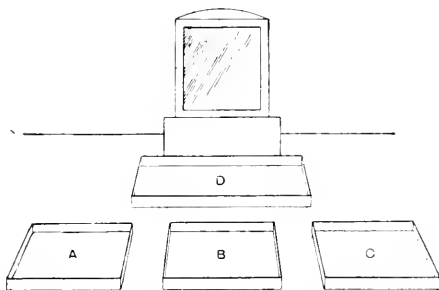

Fig. 335.—ARRANGEMENT OF DISHES FOR BROMIDE WORK.

developer, and the right-hand one is also filled with water for rinsing. The exposed prints are placed, one at a time, face downwards in dish A, with one sweep, so as to avoid air bubbles. The dish B is filled with developer, to the depth of half an inch or so, and into this they are placed face up, one by one. The dish is not to be rocked, but the bottom print is taken each time and laid on the top. In this way they are kept constantly moving and separated in the solution. An experienced hand will deal with a large number of prints in this way, but possibly about a dozen will be found as many as can be conveniently handled by the novice. The number will to some extent depend upon the concentration of the developer; as if too rapid, the bottom print will be nearly finished by the time the last one goes in. The dish should be a size or so larger than the largest print, so that when nearly done it may be drawn

aside and remain in view. When developed, the print is at once plunged into dish c for an instant, and then thrown into the hypo. bath d, which is preferably attended to by an assistant. If this is not possible, the prints in the developer must be manipulated with the right hand, and those in the hypo. bath with the left. This will necessitate arranging the dishes the other way about. In any case the solutions must not get contaminated with each other, and the prints must be kept well separated the whole time. The object of washing them after development and before fixing is to avoid stains. If this is not done, dark marks will possibly appear on the finished print; while if not kept thoroughly under the solution, they are liable to turn brown in those places left uncovered.

FIXING.

The fixing bath for prints consists of hypo. 3 oz., water 1 pint. Many prefer a plain bath of this kind, but some workers use an acid fixing bath. Experiments have shown that in a plain hypo. bath all the silver is converted into the double salt of silver and hypo. in two minutes at normal temperature. For safety, however, a thorough fixing should be given. Fifteen to twenty minutes is ample with any paper. The time of fixing is governed by the strength, composition, and temperature of the fixing bath. A strong bath, that is, one above 1 to 3, does not fix so rapidly as a more dilute one; whilst one of a strength of 1 in 20 would also be slow. The addition of alum to the fixing bath—a practice much to be condemned—also slows fixing, whilst a low temperature has the same effect. The fixing bath should be made with warm water, and diluted with cold; being used at a temperature equal to that of the developer. If made with cold water the temperature will fall very considerably, and the bath will do its work slowly with a liability to cause blisters. Fresh fixing baths should be made for every batch of prints.

ACID FIXING BATH.

The acid fixing bath cannot be recommended, but of the various formulæ sug-

gested the following is possibly the least harmful:— Sulphite of soda, 25 gr. : water, 1,000 cc. Add to this 3 cc. of sulphuric acid. Now dissolve 60 gr. of metabisulphite of potash in 1 litre (1,000 cc.) of water, and add 200 cc. of sodium thiosulphate. Previous to immersion in this fixing bath, the prints may be passed through a 5 per cent. solution of common alum. Chrome alum is sometimes added to the fixing bath, with a view to hardening the film, but is not recommended.

ALUM BATH.

Either before or after fixing, the prints should pass through an alum bath to

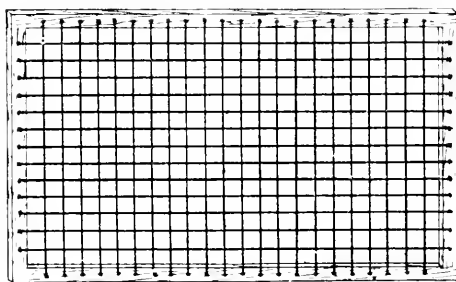

Fig. 335.—DRYING TRAY.

harden the film. The latter plan is certainly preferable, as alum carried into the fixing bath decomposes it, and is liable to cause fading. If used before fixing, the prints should be well washed. During all this time, development will be inclined to continue, and therefore the exact depth of print cannot be so well gauged. Where the prints are found to be liable to blistering, however, it is necessary to use the bath first. A saturated solution at normal temperature should be employed, in which the prints may remain five minutes. If used after fixing, the prints must be washed for ten minutes after coming out of the fixing bath, and before going into the alum.

FINAL WASHING.

The final washing should be done as described in the section on Toning, either by hand or in machines. Half an hour's washing is sufficient. The prints should then be gathered together in a heap, laid

between several folds of blotting paper, and pressed free from moisture. Blot each one, and lay face up on blotting paper in a well ventilated room, on trays consisting of wooden frames covered with muslin or string, as in Fig. 336, which may rest in racks one over the other.

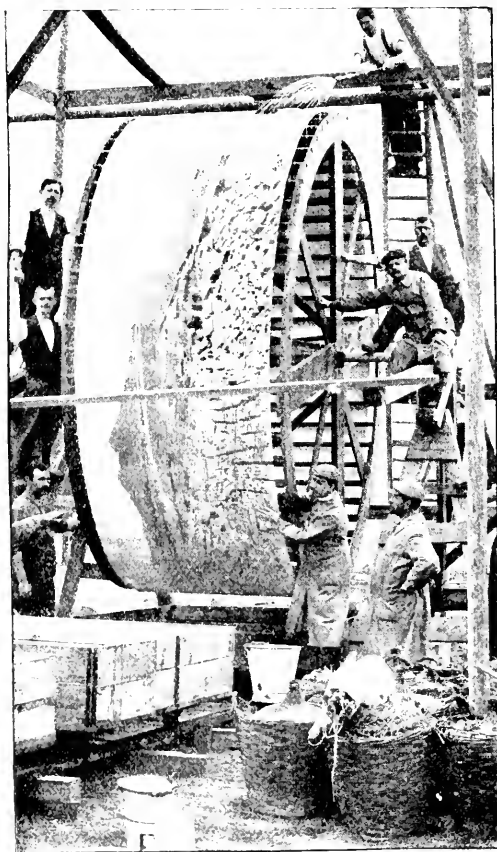

Fig. 337.—DEVELOPING LARGE PHOTOGRAPH.

DRYING THE PRINTS.

Besides the method just suggested the prints may be dried so as to give a different surface. Generally speaking, when any special surface is required it is best to choose a paper manufactured to give that surface; but, at times, it is useful to know how to alter the surface of a print. To obtain a matt surface well clean a sheet of ground opal, rubbing over with

wax dissolved in benzole or turpentine as in the carbon process, and squeegee the print down upon it. When dry, the print leaves the glass, having the characteristic grain. For enamel effects, plate glass is substituted; whilst ferrotype plate, pulp slabs and ground glass each give their particular surface. For rapid work the ordinary method of drying will take too long. In such cases the print may be dried off in methylated spirit in the following manner. Press the print between blotting-paper so that both sides are surface dry. (To obtain the fullest effect the print should be pressed, then moved and pressed again). Now immerse in clean methylated spirit for 15 minutes. The print may then be blotted again in perfectly dry blotting-paper and, if necessary, may be dried by gentle heat without danger. It is best to filter the spirit through cotton wool before use, as the commercial spirit frequently contains bits of insoluble matter which settle on the print and are difficult afterwards to remove.

MOUNTING.

Information on mounting is given in a separate section. There are no special points respecting bromide paper, since they may be treated in the same way as P.O.P. If the alum bath is dispensed with, it is perhaps preferable to allow them to dry first; but this depends on the carefulness or carelessness of the mounter, and danger is only likely to arise in hot weather, or when the paper is very tender. When mounted the prints may be worked up as instructed in the section on Working Up Prints and Enlargements in Monochrome.

ENLARGEMENTS.

The instructions here given apply also to the production of enlargements (see also section dealing with that subject), the only difference being in the method of exposure. Very large pictures have to be dealt with in a special manner. The panoramic view of the Bay of Naples, by the Rotary Photographic Co., is claimed to be the largest photograph in the world, and is exceptionally interesting. It was produced by making

six whole-plate negatives from the same point, rotating the camera on the optical centre of the lens, and just allowing a slight overlap of subject to ensure

meter, and the dishes consisted of huge vats capable of holding about 150 gal. of solution. These were arranged to run on rails 70 ft. in length. Fig. 338 shows the

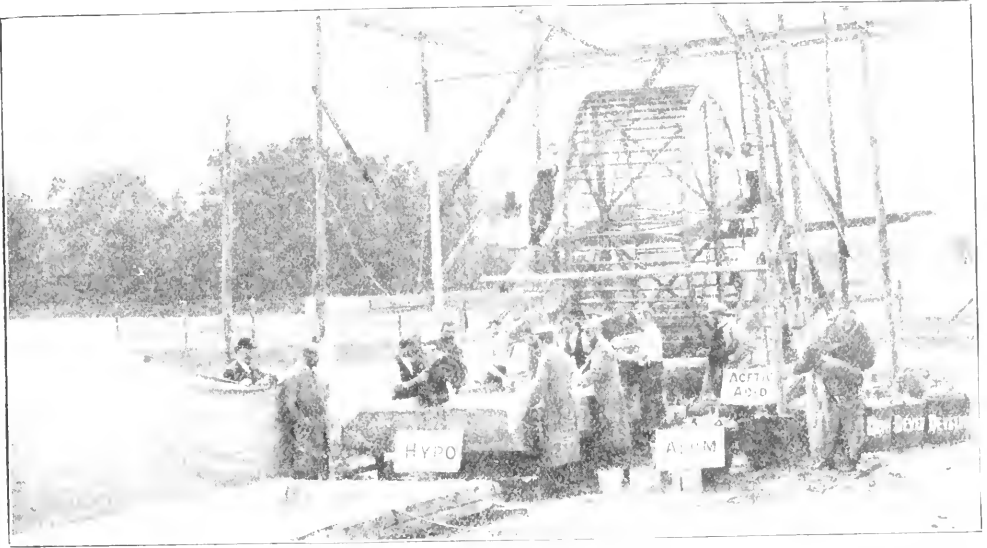

Fig. 338.—PREPARATIONS FOR DEVELOPMENT.

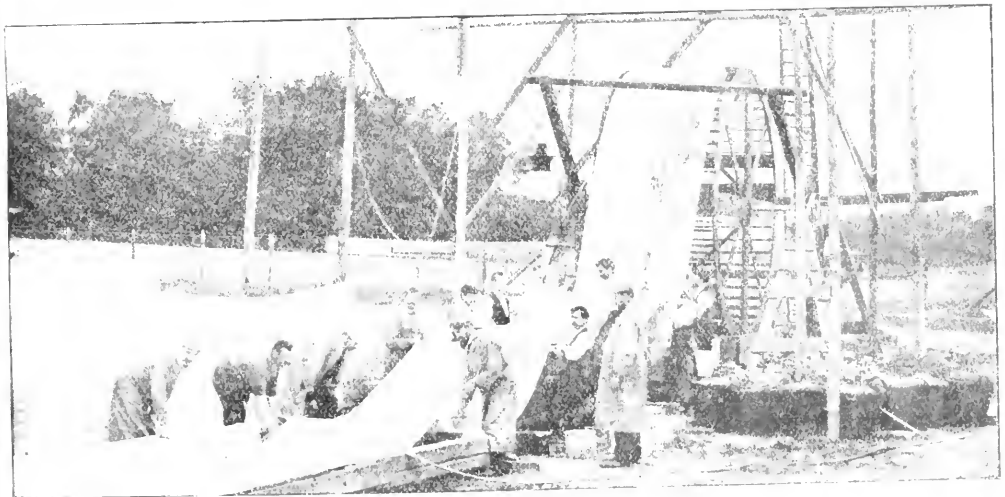

Fig. 339. TRANSFERRING TO WASHING TROUGH.

accurate register. These negatives were enlarged on a continuous band of bromide paper, 36 ft. by 5 ft. Fig. 337 illustrates the ingenious method of development adopted. The wheel measured about 12 ft. in dia-

preparations for development, which was arranged to take place in the night, as, of course, the construction of a dark room of sufficient size was out of the question. Fig. 339 shows the picture being transferred to

the washing trough, a wooden structure capable of holding 3,000 gal., and measuring 48 ft. by 6 ft. by 30 in. The sensitive paper, with an opaque outer covering, was carefully attached to the wheel, and the developing vat run into position, the protective covering being removed as the paper was allowed to go into the developer. Local development was employed on parts which appeared too light or too dark, and finally the huge enlargement was sprayed with a weak solution of acetic acid applied with a hose to stop development. Another vat with acetic acid solution was then run

print may be produced by sulphocyanide of ammonium and gold, on one which is brown from prolonged development. Take 20 grs. of ammonium sulphocyanide, and dissolve in 1 oz. of water. Mix 2 grains of gold trichloride with 1 oz. of water. The gold solution should be added to the other in small portions, well mixing. The print is immersed in this until of the desired colour.

SEPIA BROMIDES.

These are most commonly produced by the hypo-alum treatment. This gives,

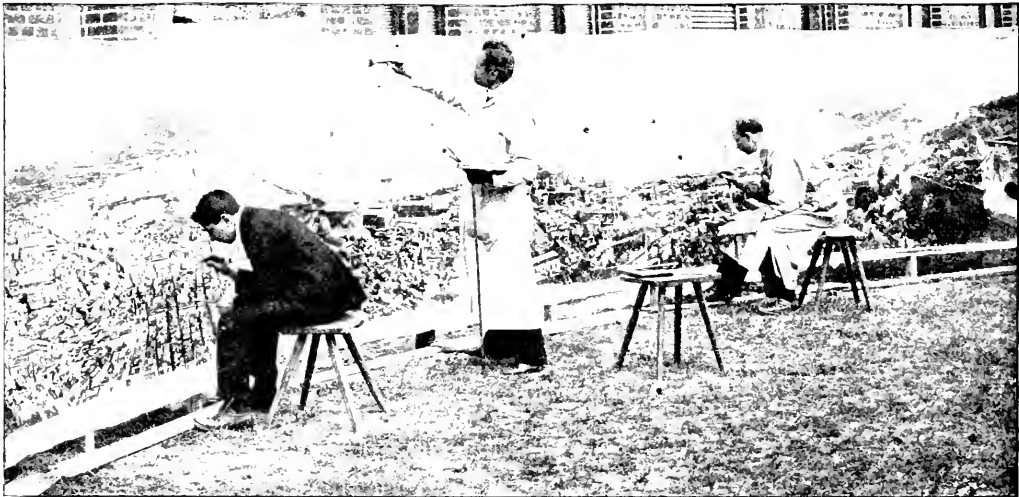

Fig. 340.—RETOUCHING FINISHED ENLARGEMENT.

into position, and the wheel rotated in this for twenty minutes. After another rinsing, it was treated with the fixing bath for three-quarters of an hour, and again flushed. Finally it was drawn off the wheel, and washed in frequent changes of water for eight hours, 66,000 gal. of water being used in the process. Drying occupied ten hours, and it was then mounted on canvas and retouched. An idea of the magnitude of the retouching operation is conveyed by Fig. 340.

TONING.

The normal colour of a bromide print being black, any other colour must be produced by after treatment. A blue-black

with a bath that has begun to work properly, a rich sepia colour. Dissolve 5 oz. of hypo. in 35 oz. of hot water, and add 1 oz. of alum. The addition of the alum will cause a thick, milky precipitate. This precipitate must not be filtered off, but remain suspended as far as possible in the solution. The prints to be toned are immersed first in the cold solution for 15 minutes, the latter being then warmed to about 130° to 140° F., and kept at this temperature for a similar time, or until the print has assumed the proper tone. The bath works very slowly at first, but gives much better results when kept a few weeks. In fact, the older it is the better it becomes. At any rate, it should not be

used for 24 hours after mixing, and should then be heated several times to about 150° F. and allowed to cool again. Some workers recommend the addition of 1 oz. of granulated sugar. A new bath bleaches the print more than an old one. After toning, the prints should pass into a bath of water 20 oz., alum $\frac{1}{2}$ oz.; which should not be quite cold. The prints are then finally washed for 20 minutes.

GASLIGHT PAPERS.

During recent years some extremely slow papers have been placed on the market which may be developed in tolerable safety a yard or so away from the light used for exposing, by using a fairly energetic developer. This is made possible by the fact that development is fairly advanced before the light can take much effect, or in a much shorter time than that needed for exposure, whilst the extra distance from the light is an added safeguard. This opens up a point for the consideration of the novice—namely, that it is not only the light used for development which must be considered, but the length of time the plate is exposed to it compared with that necessary to produce an image. This explains why some photographers who work smartly and quickly can use a light which another will find causes fog. Too often an operator will take out the plate or paper before he is ready for it, and leave it exposing for several minutes while he is doing something which might have been done before.

PRODUCTION OF TONES BY DEVELOPMENT.

As such papers may be developed in ordinary gaslight, they are called gaslight papers. Now these papers are found to yield, by means of a greatly increased exposure and prolonged development, a variety of very pleasing colours direct, without the aid of a toning bath. If, therefore, one of these papers, such as Velox, Gravura, etc., is exposed for, say, five or six times the normal, and is then developed in a very dilute and highly restrained developer, it will be found that at the end of about two minutes it will appear as a pale yellow image, slowly

changing to red, then to brown, and finally to a sort of olive green.

FIXING AND DEVELOPING.

Suppose now that four prints are given identical exposure in the proportion of six times that required for an ordinary print, and are then developed as above, and that one of them is removed to the fixing bath in the yellow stage, another in the red stage, and another in the green; they will first of all undergo a change of colour in the fixing bath, but on drying they will regain the colour which they possessed when they left the developer. For this purpose make up the following: (No. 3) Ammonium bromide, 1 oz.; ammonium carbonate, 1 oz.; water, 20 oz. It is essential that the carbonate of ammonia should be in clear lumps. If it is covered with white powder it should be discarded. Carbonate of ammonia must be kept in a well-stoppered bottle, or the ammonia will be lost. The method given is practically that recommended by the Paget Prize Plate Co. for use with their "Gravura" paper, with which excellent results have been secured. The formula for development is as follows:—For warm sepia: Normal developer, 1 oz.; restrainer, 1 dram; water, 6 oz. For red: Normal developer, 1 oz.; restrainer, 4 drams; water 1 pint. The normal developer is:—Hydroquinone, 55 grs.; metol, 14 grs.; soda sulphite, 1 oz.; soda carbonate, $1\frac{1}{4}$ oz.; potassium bromide, 2 grs.; water, to 20 oz. The length of time occupied in development will vary greatly. In the case of red, the development sometimes takes six or seven minutes. Whether the desired colour will have been obtained at the same time as the appearance of the correct amount of detail is a matter which is regulated by exposure, and must be found by experiment. Exposure in sections, as before recommended, will be advisable. A warm sepia usually requires about six times as much as is needed for the ordinary colour, and a red print eight to ten times. If the exposure is insufficient, the colour will be greenish by prolonged development. To obtain any given colour with certainty and precision requires some skill and experience.

TONING BROMIDE PRINTS IN VARIOUS COLOURS.

One of the simplest methods of toning bromide prints, as it is usually called, is by the uranium process. This gives a variety of shades of brown between sepia and a bright brick red. The uranium ferrocyanide deposited on the image is an opaque colour of a brilliant red, so that almost any colour between black and red is obtainable.

THE URANIUM PROCESS.

As this is not really a toning process, but a modified form of intensification, it is essential that a proper print should be made. It must be somewhat lighter and weaker than would be required in the ordinary way, but how much lighter will depend upon the colour that is to be produced. The longer the "toning" the redder the colour, and as the longer the toning the greater the increase of intensity, it follows that the redder the tone desired the weaker and lighter should be the print, otherwise it will appear too hard and dark. It is also essential that the print should be produced by one of the non-staining developers, not by the ferrous oxalate. The presence of iron in the print will cause blue green spots. The print must be thoroughly fixed and washed before treatment. The following bath is recommended: Uranium nitrate, 20 grs.; potassium ferricyanide, 18 grs.; acetic acid, $\frac{1}{2}$ oz.; water, 10 oz. In making up this bath, it is essential that the ferricyanide (or red prussiate of potash) should be in good condition. If it has been much exposed to the air it will be covered with a yellow powder, which leads to bad results. When in this condition it should be washed free from this yellow prussiate. Cover a few of the crystals with water, swirl round for a moment, and decant off. Then scrape them out on to a clean filter-paper or blotting-paper, and dry thoroughly. They may be placed in the oven to dry. The crystals should now be quite clear and of a bright ruby colour. Dissolve them in half the water, and the uranium salt in the other half, and pour

the former into the latter, and when the acetic acid is added a clean red solution should result.

ACID BATH.

To obtain the best results, it is essential that the prints should all the time be in an acid condition, and therefore an acid bath, strength 1 in 60, should be ready to receive them when toned. Acetic, citric, or even pure hydrochloric acid may be used.

METHOD OF TONING.

Of the actual method of treating the prints when in the toning bath, little need be added to the instructions already given. With this bath, however, it is necessary to remove the prints before the actual tone has been reached, as they become somewhat redder in the acid bath. Two or three minutes in the acid bath is ample, and they may then be soaked in several changes of water for half an hour, but not longer. The uranium ferrocyanide deposited on the prints is soluble in extremely dilute alkaline solutions; therefore, unless the paper is fairly acid, the toning may be dissolved out in the process of washing, leaving the print faint and weak. A print which has been toned with uranium in this manner may be instantaneously changed to a blue-green or moonlight effect by immersing the print in a weak solution, say 1 in 20, of ferric chloride, or perchloride of iron as it is sometimes called. The prints should be dried and mounted as usual. Yellow whites may be avoided by adding a little more acetic acid to the bath. On no account should the prints be washed under the tap, or they will be patchy.

OTHER TONING FORMULÆ.

On the opposite page is given a list of formulæ for imparting various other tones. The prints are feebly developed with eikonogen, fixed, washed, and then immersed in a solution of nitrate of lead 4 parts, potassium ferrocyanide 6 parts, water 100 parts. When placed in this solution, the image is at once bleached to a pale tint, and the

print may then be coloured by immersing in any of the following:—

Yellow.

Neutral chromate of potash	4 parts.
Water	100 parts.

Brown.

Schlippe's salt	10 parts.
Ammonia	5 "
Water	150 "

Green.

Immerse yellow prints in—

Iron perchloride... ..	1 part.
Water	10 parts.

Nickel Green.

Chloride of nickel	1 part.
Water... ..	10 parts.

Red.

Immerse yellow prints in—

Chloride of copper	1 part.
Water	10 parts.

Orange.

Bichloride of mercury... ..	3 parts.
Iodide of potassium	4.5 "
Water	100 "

To obtain a blue colour, the prints may without bleaching be placed in the following solution: Citrate of iron and ammonia (sat. sol.), 1 dram; potassium ferricyanide (sat. sol.), 1 dram; hydrochloric acid, 2 drams; water, 5 oz.; and are then well washed. If the solution is diluted, a darker blue results.

EXCESSIVE CONTRAST.

The print possesses excessive contrast, with greenish-black shadows, and is wanting in detail in high lights. Causes.—(a) Too brief exposure, causing the print to be developed too long in hopes of obtaining detail in high lights; or (b) the negative is too hard for the process. Remedies.—(a) Passing by the obvious remedy of giving longer exposure next time, which, generally speaking, would meet the case, it being cheaper to throw away the spoilt specimen and produce another, the print may be reduced by immersion in the iodide or ferriyanide reducer; though

perhaps the best reducer is persulphate of ammonia. Immerse the print in a 2 per cent. solution of ammonium persulphate until the shadows are sufficiently reduced, then transfer to a 5 per cent. solution of soda sulphite for a few moments and wash; (b) If a large number of bromides are to be made, it will be best either to reduce the negative or to reproduce it with softer contrasts. Failing this, the most rapid paper should be used and a dilute developer, and the negative exposed as near to the light as practicable.

FOG.

The print is fogged. Causes.—Fog may be either "chemical" or "light." If chemical, it may be caused by (a) an error in manufacture, (b) improper storage, (c) having the developer too strong, (d) over-development, (e) hypo. in developer. The causes of light fog are various, and will doubtless suggest themselves, such as unsafe dark-room lamp, exposing the paper too long to the rays of the lamp, etc. Remedies.—(a) This is the least likely, but if suspected, return the sample to the makers. (b) Carefully consider the conditions of storage. If purchased from a chemist, inquire how long it has been in stock. (c) The developer should never be so strong as for plates. It is customary to use it at only half the strength by diluting with an equal bulk of water. (d) Remove the print from the developer the instant it shows the required detail in high lights. This should be arrived at in two to three minutes; if it is not, the exposure was too short or the developer too weak. (e) Exercise more care in dealing with the hypo. solution.

FLATNESS.

The print is flat with grey shadows. Causes.—(a) Developer weak, (b) over-exposure, (c) flat negative. Remedies. (a) Make up a new bath. (b) The remedy is obvious. Generally flatness from over-exposure is accompanied by fog all over the print. Perhaps the clearest indication of this is the rapidity with which it develops, supposing the developer to be correct. (c) If possible, the negative should be

intensified; but if this cannot be done on account of retouching upon it, or when it is specially prepared for some other process, to procure the best result use the slowest paper available (Carbon Velox is especially suitable), and expose to a dull light beneath green glass. That known as "Cathedral" green should be used. The frame should be exposed farther from the light.

YELLOW STAIN.

Yellow stain over the whole print. Cause.—(a) Developer too slow, (b) weak developer, (c) contaminated hypo. bath, (d) placing prints direct from developer into fixing bath without rinsing, (e) allowing the print to come above the surface of the solution. Remedies.—(a) Use less potassium bromide or other restrainer. (b) Use a fresh solution. (c) Always use a clean hypo. bath for each batch of prints, and discard before it shows signs of discolouring. (d) Rinsing is particularly important where a number of prints are being dealt with. (e) Keep the print carefully under the surface and away from the air until washed.

PATCHINESS.

Yellow patches on the prints. Causes.—(a) The prints have been allowed to stick together in the fixing bath, (b) the prints have had air-bubbles on their surface whilst fixing or washing, (c) insufficient fixing. Remedies.—(a, b) Obvious. (c) These stains do not appear until some time after the print is dry. They may be removed by rubbing gently with a dilute solution of iodine in potassium iodide, applied with a Buckle brush (see p. 230).

SPOTS.

White spots on prints. Causes.—(a) Dust on negative, (b) air bubbles on the surface of the paper during development. Remedies.—(a) Always carefully dust the negative before placing the paper in the frame. See that there is no dust about in the room when printing. Always have the floor sprinkled before it is swept. (b)

Soak the paper before development in clean water. In immersing the paper, push it in rapidly with one sweep. Do not allow the papers to cling together.

BLACK LINES.

Sharp black lines on the print. Cause.—Scratching the surface. Remedy.—Rub gently with a tuft of cotton-wool moistened with methylated spirit or ammonia solution 1 in 200, about.

BLISTERS.

Blisters. Causes.—(a) Solutions not kept at same temperature; hypo. too cold or too hot; (b) hypo. bath too strong. Remedies.—(a) Always mix hypo. with warm water and allow it to cool to proper temperature. (b) Obvious. Blisters may be avoided by using the alum bath before fixing. Some papers are much more liable to them than others. When a print is badly blistered, the best plan is to prick the blister gently with a needle and immerse the print in methylated spirit. This should be done after washing. Blisters may also be obliterated by drying in contact with ground glass.

STAINED HIGH LIGHTS.

A print toned in uranium bath has yellow high lights. Cause.—Too small a quantity of acetic acid has been used. The remedy is obvious.

SOLUTION OF DEPOSIT.

A print similarly toned goes patchy in washing. Cause.—Placed under spray or tap to wash. Remedy.—Soak the print only in a dish, and see that the water is not alkaline. Do not wash more than five minutes; and if the high lights are yellow, immerse in sulphocyanide of ammonia, 3 grs. to the ounce.

STAIN REMOVER.

To remove yellow stains which have occurred on a bromide print through prolonged development, the following is recommended: Tartaric acid, 1 dram; soda sulphite, $\frac{1}{4}$ oz.; hypo., 3 oz.; water, 1 pint.

TONING WITH GOLD AND PLATINUM.

INTRODUCTION.

WHEN a silver print has been removed from the printing frame, it is found to be of a reddish brown or violet colour, and, of course, still sensitive to actinic light. To remove the sensitive salts which have not been acted upon by the light, it is necessary to use one of the various fixing agents, which will be considered later. If the print is merely fixed, however, the result is unsatisfactory, the colour being some shade of brown or yellow. To change this deposit, which consists of metallic silver, the usual method is the substitution of gold or platinum for the original silver. Gelatino- and collodio-chloride papers are coated with gelatine or collodion emulsion, which is chiefly composed of silver chloride, free silver nitrate, and citrate; and the chemical change produced by the action of light differs in degree according to the varying intensity of the light, the reduced silver chloride being in a suitable physical state for the deposition of another metal.

TONING ACTION OF GOLD AND PLATINUM.

The chemistry of toning this class of paper is comparatively simple, the important part of the action of gold chloride being expressed by the equation



(Silver and gold chloride form silver chloride and gold.)

Other metals might be used, but gold and platinum are at the present time universally employed for P.O.P., collodion, and albumen papers. The bath should be either neutral or alkaline; if acid, the

image will be attacked, and unsatisfactory tones produced. The neutral bath gives splendid purple tones, but is slower in action than one with a slight excess of alkali. In this latter bath, the gold chloride is first reduced from auric chloride (Au Cl_3) to aurous chloride (Au Cl). This is a slow process, so that the bath is best left standing a short time before use. An atom of gold is then deposited, taking the place of one atom of silver, as in the equation previously stated. In

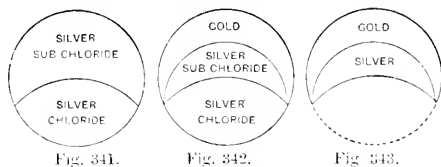

Fig. 341.—SILVER IMAGE AFTER PRINTING.

Fig. 342.—SILVER IMAGE AFTER TONING.

Fig. 343.—SILVER IMAGE AFTER FIXING.

the same manner, platinum is deposited in the place of the silver.

THE THEORY OF TONING

is not yet wholly understood, nor is it certainly known what exact physical change takes place when the silver image is replaced by the gold. It is almost generally accepted that the particles of silver chloride and free silver are acted on by the gold upon the top surface only, which it replaces; the lower portion of the particles remaining unaltered. A certain proportion of the chloride of silver is also left. Fig. 342 gives an idea of how the gold is deposited (see also Figs. 341 and 343). Gold trichloride is the commercial form of the toning metal now in general use.

If used alone, the gold trichloride would give a blue image, which, on being fixed, would be excessively weak. This is accounted for by the fact that one atom of gold would take the place of three atoms of silver. The image would therefore be less vigorous, as shown by the equation

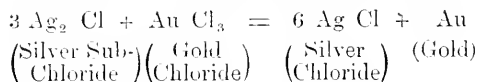

Fortunately, gold chloride exists in two states, the auric and the aurous: the latter differs from the former in possessing only one atom of chlorine instead of three, and therefore does not effect such a great reduction of the image. Thus

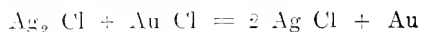

This chlorine must be removed, and sulphocyanide of ammonium, which is a chlorine absorbent, is largely used in conjunction with the gold trichloride. For this purpose, instead of sulphocyanide of ammonium, the acetate, bicarbonate, phosphate, or tungstate of soda, and other neutral or alkaline salts, are employed.

COLOURS OR TONES AVAILABLE.

Neutral and slightly alkaline baths tone very quickly, if used immediately they are made: heavy, dark tones being produced. After standing a short time, the baths work slower, and lose their activity gradually: the tones are, however, bright and most permanent. The permanent colour is produced gradually, from shades of pink and rose, to copper-red, purple, chocolate, and in some cases black. The platinum bath is especially suitable for shades of sepia-brown. The colour will vary with most of the numerous toning formulæ, and also with the different brands of paper. The quantity of gold and platinum in the bath, and, perhaps of more importance, the readiness of the metal (or, more correctly, its chloride or other salt) to replace the original silver, influence the ultimate tone. It will thus be seen that special precautions are necessary for special effects; and that a variety of results are obtainable from the same formula by adopting different methods.

INFLUENCE OF THE NEGATIVE ON TONE.

The negative from which the print is taken exercises much influence; and it has been said that the quality of the negative determines the quality of the tone. This is so far true, that strong, plucky negatives, inclined to be hard, give most readily purple and black tones; and, on the other hand, weak negatives, those showing little contrast, can rarely be toned satisfactorily to the purple stage, and are at their best when they reach red-brown.

INFLUENCE OF METHOD OF PRINTING ON TONE.

Then, again, as previously stated, the intensity of the light when printing is an important factor. It is found, and no doubt has been generally noticed, that in some instances the unfinished prints from the same negative vary considerably in colour. Those exposed to intense light, when the action is sudden, are distinctly red in appearance; and those printed slowly, by well diffused light, are inclined to the violet shades. The difference is a physical one, and caused by the more gradual, and complete, reduction of the silver. The colour is not so important, in this case, as the effect of the more gradual reduction. In the case of the red image, there is a certain want of proper rendering of the tone values of the negative, *i.e.*, the intense light destroys the half-tones, and does not correctly reproduce the harmonious gradations. This refers, of course, to prints taken from good average negatives. Slow printing is therefore essential for bright and strong prints, those which can be satisfactorily toned. Slow printing should, however, not be carried to extremes: as, if prolonged unnecessarily, delicate half-tones will not be reproduced, and the resulting print will show more violent contrast than the negative. This fact should be remembered when the negative is not perfect; but the principal idea must be kept in mind, that from plucky negatives, brightly toned purple prints are most readily obtained, the tone varying according to the negative.



1 PLAIN PRINT. HAIR, FACE, AND BACKGROUND TOO DARK. INSUFFICIENT DETAIL IN DRESS.

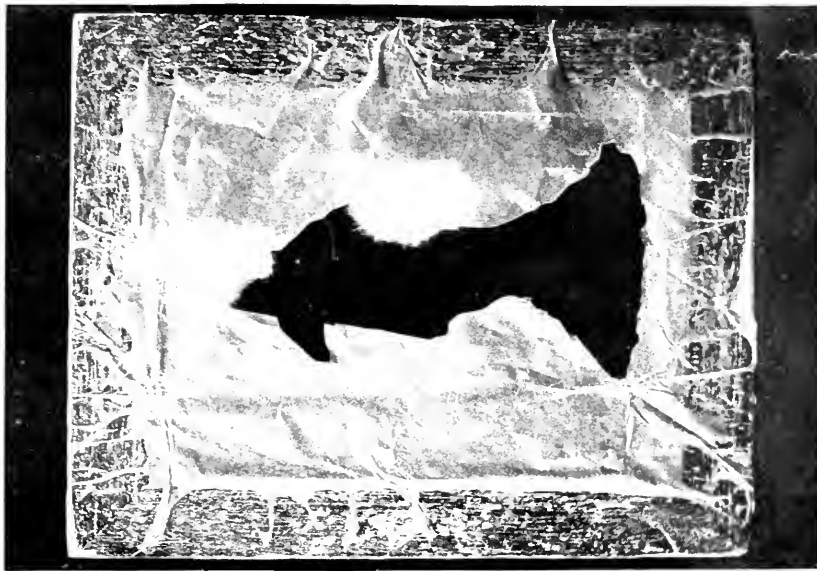

2 PRINTING FRAME FITTED WITH TISSUE PAPER AND COTTON WOOL.



3 DODGED PRINT. NOT TOO LIGHT. HAIR, FACE, AND BACKGROUND, AND PERFECT DETAIL IN DRESS.

EXAMPLES OF DODGING

CAREFUL WORKING ESSENTIAL.

Many more or less explicit explanations have been written on the subject of gold and platinum toning, but the tyro will do well to study this more elementary treatment of the subject. A great deal of time and trouble will be saved if, before proceeding to print, an examination is made of the materials which are to be used. As will be seen later, failures and difficulties are very often the result of bad tools, and of these, surely a bad negative is a tool to be despised and cast aside. The theoretical side of the toning action of gold and platinum must be studied, and its elementary practice at any rate understood thoroughly. The practical is, of course, the main point. Every effort will be made in this section to include all necessary formulæ, with explanatory notes, but the toning methods are so various that the novice is advised to take up one well-tried brand of paper, with one particular toning bath, and study them well. In this way, success should be ensured, but the constant changing of papers and baths is strongly deprecated. Excellent effects can be obtained with all processes if carefully worked, and although the tyro may not succeed at once in getting perfectly toned pictures, yet if he will consider the process thoughtfully, the difficulties will soon disappear.

PRESERVATION OF UNTONED PRINTS.

Great care must be taken to prevent light or moisture getting to the prints before toning; but they will keep untoned for some time if proper precautions are taken. Untoned albumen prints are not so stable as P.O.P. and collodio-chloride. The latter have been kept for more than two months after printing, between the leaves of a clean blotting book, without showing any sign of deterioration, either in appearance when finished, or in comparison with other prints toned immediately after printing. Albumenised paper, however, should be finished at once. Untoned prints of this description must not be kept for more than a day or two, as it is found that the high lights of the prints

rapidly become yellow, and when transferred to the toning bath the action is uneven, and the resulting fixed print disagreeable in colour. In fact, some albumenised prints kept with the P.O.P. prints for two months refused to tone at all, although the same care had been taken to preserve them.

PRELIMINARY WASHING.

It is advisable, however, when possible, to tone silver prints immediately after printing. Some workers trim their prints before toning. This is a mistake, as the edges are pretty certain to be abraded during the various operations, thus necessitating a second trimming. The edges, however, should not be rough, as they are apt to scratch the surfaces of other prints. The first stage is the thorough elimination of all free silver salts and free acid by washing in water. Upon this washing depends the quality and evenness of the toning action, also, to a large extent, the permanency of the print. The presence of this free silver tends to yellowness of the high lights, and generally to the gradual deterioration of the image. This part of the process is very liable to be hurried over by the photographer, but its importance is so great that too much emphasis cannot be laid upon the necessity of thoroughly removing any free acids, or silver salts. Citric acid and silver nitrate will contaminate the toning bath, causing slow toning with most baths, besides being a constant source of double toning.

LIGHT FOR TONING.

This washing is best done in well diffused daylight; the weaker the light the better, but it should be sufficient for the operator to see the colour of the print easily. The ordinary lamp or gas light is not good, as it is difficult to judge colour properly by these means. Where daylight cannot be used, incandescent gas is far preferable to most other sources of light. The whiter the light the better; and of course a minimum quantity only must be allowed to fall on the prints.

METHOD OF WASHING.

There are several excellent washing machines on the market, but at this stage the prints must not be left unattended, and washing by hand is preferable. For twelve prints, half-plate size, take two porcelain dishes, which must be chemically cleaned, filling each with clean water. There is a distinction between ordinary cleanliness and chemical cleanliness. To ensure the latter, it is a good plan to make up a solution of potassium bichromate 1 part, sulphuric acid 1 part, and water 20 parts. This may be used repeatedly. Pour it into the dish or measure, and rinse round. Then wash freely in water. This mixture must not be allowed to get on the clothes or fingers. The dishes should be deep, and at least a size or two larger than the prints, say $8\frac{1}{2}$ in. by $6\frac{1}{2}$ in. Place six prints, one at a time, in the first dish, keeping the water steadily moving. The latter will speedily become like milk, in consequence of the rapid formation of silver chloride by the combination of the soluble chlorides and silver nitrate. After a minute, transfer the six prints, separately, into the second dish, pour off the milky water, and refill. When another two minutes have elapsed, transfer the prints back to the first bath. Pour off the second milky water, and refill, placing the second six prints in the clean water. The water in the first dish will be now found to be much less affected than before, which shows that most of the soluble salts have been eliminated. These first prints must be removed to another dish, and the whole so interchanged that they have each at least six separate changes of water. The prints should be left in the last three changes for a longer time than in the early ones, as while the free chemicals are liberated quickly at first, the action is not thorough, and the final removal takes place gradually. The prints should be placed in the water face upwards, although if they are constantly moved about, and care taken that they do not touch one another, this is not very important. The last water

should remain quite clear. The time taken with the six washings is about ten to fifteen minutes. Some workers prefer to use rain-water in which has been dissolved a small quantity of common salt. This certainly has the advantage that the printer knows exactly what he is using—a state of things not existing when ordinary water is used, in which a variety of earthy salts are dissolved. It is, however, an unnecessary refinement.

ALUM BATH.

The following bath is one which is often omitted by some of the most particular workers, and yet others consider that it is almost indispensable for several reasons. It is known as the hardening bath, and is best made up as follows:—Chrome alum, 20 grains; common salt, 1 oz.; water, 20 oz. Instead of chrome alum, the ordinary variety of powdered alum may be used, in which case take $1\frac{1}{2}$ oz. The prints, after aluming, are much more easily and safely handled in the subsequent stages; which is a strong point when time and clean work are considerations. It is best to alum the prints before toning, as the slightest contact with the fixing agent will be fatal, and cause yellow stains. For enamelled prints, or those to be hot rolled and burnished, this bath is absolutely necessary, since the film is toughened, and therefore better able to bear the heat and pressure. On the other hand, those which are to be mounted in optical contact should not be so treated. The salt is added to the bath, not only for the purpose of converting any free silver salts in the paper into chloride, as before explained, but because it is also a great preventive of black spots, due to water charged with metallic impurities. Rust from iron pipes through which the water flows is a constant source of such troubles in old houses, or where the water is allowed to stand in the pipes for long periods. The prints must be kept constantly on the move, and should remain soaking in the alum for five to ten minutes (of course, in winter the time may be much shorter than in the warmer season), care being taken that they do not stick to one

another. On removal from this bath, again well wash in three or four changes, or, better still, in gently running water, for ten minutes, by which time they will be ready for the toning bath.

GOLD TONING FOR P.O.P. AND COLLODIO-CHLORIDE PAPERS.

In the following various formulæ for making up the toning bath, the quantities

in a far shorter time than the older albumenised paper, and it is probably this point, more than any other, which has made the paper so popular among amateurs. Toning prints from average negatives should be completed in six to ten minutes; and it is advisable that it should not take less. In warmer weather, toning will appear to be finished in less time, but it will be merely a surface tone.



Fig. 314—THE OPERATION OF TONING PRINTS.

of the chemicals given are such as have been proved to give the best results on well-known brands of P.O.P. and collodion-chloride paper now in use. The colour produced is largely dependent upon the amount of gold deposited by the bath. Most of the formulæ produce the warm tones readily, while some are more suitable than others for giving purple tones.

TIME OF TONING.

Emulsion papers toned in sulphocyanide or such baths assume the desired colour

This surface tone will be found to be soluble in the fixing bath, and therefore of no practical effect. The prints should remain in the bath until the colour, when viewed by transmitted light, has reached the desired tint. The toning must be allowed to proceed until there is only just a trace of warmth in the shadows of the print when viewed by transmitted light, that is to say, when held up to the light and looked through (see Fig. 314). The exact time to stop toning, or the exact amount of tone, must, as in the case of

developing, depend upon the subject and the taste of the operator.

SULPHOCYANIDE BATH.

The following formula is recommended by Ilford, Limited—who may be looked upon, commercially, as the pioneers of the process—for use with their well-known P.O.P., but it is an excellent all-round toning bath with all gelatino-chloride papers:

Ammonium Sulphocyanide	20 grs.
Water	20 oz.
Gold Chloride	2 grs.

This is a sufficient quantity to tone a sheet of paper 24½ in. by 17 in., or twenty-eight pieces quarter-plate size, to a cold purple colour in ten minutes. For warmer tones, the bath may be diluted with half as much more water; but the proportions of gold and sulphocyanide should not be altered. The diluted bath would tone 1½ sheets of P.O.P. Cold water may be used for making up this bath, but for best results the sulphocyanide should be dissolved in 10 oz. of boiling water; and the gold chloride, after having been also dissolved in the other 10 oz. of boiling water, is added very slowly to the sulphocyanide solution, well stirring. If this latter method of mixing is adopted, the bath may be used when cooled to 60°, otherwise the mixture should stand for about twelve hours before use. This is a point to which the amateur seldom pays proper attention, the bath often being made up with cold water and used immediately. The only serious result to be feared is a reduction of the image through the aurous salt not being formed. This is very evident on placing it in the fixing bath.

CHEMICAL REACTIONS OF THE SULPHOCYANIDE BATH.

The exact method of compounding the bath is considerably more important than might at first appear. There are certain points to consider, which must be carried out with equal care in various baths. The first of these is that the gold must be added last, as noted in each of the formulae given. Secondly, that within certain well defined limits, a slight alteration in

the amount of sulphocyanide is not important. When gold solution is added to the solution of sulphocyanide, it first of all changes to a bright red, and afterwards becomes clear again. The changes are almost instantaneous, or should be if the bath has been properly made; but they are sufficiently marked to be observable by every printer. This indicates that some new compound is formed on the addition of the gold, which is afterwards redissolved, and such is found to be the case, as shown in the formula



(Gold trichloride and ammonium sulphocyanide give gold sulphocyanide and ammonium chloride.) Now, gold sulphocyanide is a bright red compound, so that this is what has been formed in the solution. It is redissolved in excess of ammonium sulphocyanide, giving a double salt of gold-ammonium sulphocyanide, having the abbreviated formula Au (Cy S) Am Cy S . (In all these remarks it may be taken that the potassium salt may be substituted for the ammonium, wherever preferred, and used in exact proportion to its chemical equivalents.) Fuller information on the chemistry of the process is given in the theoretic section. This is the substance which it is desirable to form. It follows, then, that sufficient of the salt must be used to accomplish the purpose of redissolving the precipitate. The exact quantity required is easily estimated by the molecular or combining weights, and will be found to work out as 3 is to 4. That is to say, 3 grains of gold require 4 grains of sulphocyanide. Now, many formulae give a much greater quantity, and it has been found by experiment that practically no difference occurs between the use of 5 grains to 10 grains to each grain of gold. Above this, however, there is, with certain papers, a danger, but this depends on (a) the temperature, and (b) the melting point of the gelatine used for the paper. When the solution contains too much sulphocyanide, it attacks the gelatine, softening it, and making it peculiarly liable to abrasion and finger marks. With some brands of paper, 15 to

20 times the amount of gold may be used, even in warm weather; but with others it is not advisable to go above 10 times. The necessary modifications of the formula may be easily determined from the information already given.

EFFECT OF VARYING THE AMOUNT OF GOLD.

The effect of varying the amount of gold, on the other hand, is very marked, and the greater the proportion of gold the bluer and colder is the tone, and the shorter the time of toning. An excess of gold over that given in the formula cannot be recommended. To make this still clearer the following experiment has been suggested. Take a small quantity of phosphorus about the size of a pea, and dissolve it in ether. Add this to water in the proportion of about 1 drop to 5 oz. Now pour into this 5 drops of gold solution (1 grain in $\frac{1}{2}$ oz.). The gold will very slowly be reduced, and will come down a bright red colour, the reason for this being that the particles are in such an extremely fine state of division. In the case of adding to the gold solution anything which produces immediate or rapid reduction, the gold will be found to be of a deep blue, almost purple. From this it will be seen that reduced gold is of two colours, dependent upon the rate of reduction. If, now, the toning goes on slowly, either on account of deficiency of gold or other causes, the deposit will be reddish, and depositing red upon red can never make much difference to the colour. What is required, then, generally speaking, is to deposit the blue particles, which shall combine with the red to form a pleasing purple tone, and this can only be effected by having the bath of proper strength.

TEMPERATURE.

It may, however, happen that the bath is of correct strength, yet will not give the desired tone. This is usually to be explained by the temperature. A cold toning bath causes the gold to be deposited very slowly, and there is therefore a tendency towards a red tone in such

circumstances. (This is a practical point for those workers to remember who complain that certain baths act too quickly to give a warm sepia tone.) The proper temperature of the bath is 60° F., but there are occasions when it is quite permissible to allow it to be slightly above this; all will depend on the result desired.

DILUTION.

The dilution of the bath does not appear to have any effect, and the water may therefore be looked upon as merely a medium for the action. The best method in toning either on a large or small scale is undoubtedly that of calculating the exact amount of gold required for the given area of silver chloride, adding the amount of sulphocyanide or its equivalent in proper proportion, and diluting with sufficient water to handle the prints conveniently. It must be noticed, however, that it is the area of silver chloride which is to be borne in mind, not the area of the paper; for, in some cases, in two sheets of paper of the same size, one may have more than double the quantity of reduction product possessed by the other. Therefore, the darker the prints the more gold will be required.

METHODS OF PREPARING THE BATH.

There are two methods of preparing the bath. In one, it is mixed with cold water and ripened for twenty-four hours or so; and in the other hot water is used for mixing, and the bath used when cold. Both these methods lead to the same

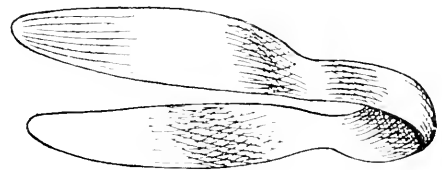

Fig. 345.—CLIP FOR LIFTING PRINTS.

result, and ensure the formation of the aurous salt. The prints must all be put together into the bath, or the tone will vary; the majority of the gold being used

up on those first put in. In toning the prints, it is essential that they should be handled as little as possible. This is especially the case where the printer does any other work with chemicals. For handling the prints a vulcanite clip, as shown in Fig. 345, is a convenience. It is tipped with cork, and holds the print very lightly. Some printers will gather the prints all together on the left hand, and peel them off one by one, plunging them face down in the toning bath. This method is employed at one of the finest establishments in the trade, which is noted for the beautiful tones of its productions. Many printers, however, attempting the same method, have only succeeded in producing blotchy, uneven tones with a fine crop of finger marks. This fact is mentioned to show that the actual system is very much a personal matter. It may be safely said, however, that the less handling the prints have, the cleaner and purer the chemicals and dishes employed, and the more accurately the bath is prepared, both as regards strength and temperature, the better are the chances of success. The fact that some expert workers are able to do things which seem to contradict all elementary rules is of no importance.

CONCENTRATED SULPHOCYANIDE BATH.

This bath will not keep, as a rule, the gold being precipitated, but we are indebted to Buhler for the following concentrated sulphocyanide bath:

Distilled Water	1 oz.
Gold Chloride	8½ grs.
Strontium Chloride	85 grs.

Heat the water to 200° F., add the gold and then the strontium. Next add:

Potassium Sulphocyanide	25 grs.
Distilled Water	7 drams.

Heat the solution to 200° F., cool and filter, and make up total quantity to 2½ oz. For use, take 1 part stock to 19 parts of water. This bath keeps indefinitely in the dark.

BICARBONATE OF SODA BATH.

Soda Bicarbonate	30 grs.
Water	10 oz.
Gold Chloride	1 gr.

This bath is especially suitable for purple black and blue tones. It has the advantage of being ready for use immediately it is mixed, but it will not keep for any length of time. After use, it must be thrown away, since it is not suitable for diluting a new bath.

ACETATE OF SODA BATH.

Sodium Acetate	30 grs.
Water	10 oz.
Gold Chloride	1 gr.

Good purplish-brown tones can be obtained by using the sodium acetate bath. It will be found to work better if mixed forty-eight hours before use. Hot water is most satisfactory; the gold chloride being added after the acetate has been dissolved. Before adding, however, it is advisable to neutralise the gold solution by the addition of a few grains of common chalk. After having been used, the bath should be stored in ruby coloured bottles, or in the dark, and may be used, after filtering, to dilute a new toning bath.

BICARBONATE AND ACETATE OF SODA BATH.

Sodium Bicarbonate	20 grs.
Sodium Acetate	240 grs.
Water	10 oz.
Gold Chloride	10 grs.

This is a concentrated bath; for use, take 1 oz. solution, and make up to 10 oz. with water. It should be mixed with hot water, the gold and bicarbonate being first dissolved in two or three ounces, and left standing for an hour or so. The acetate being dissolved in the remainder of water, the two are slowly mixed. This compound bath can be used at once, but for best results it should stand for forty-eight hours. After use, store in ruby bottles, or in the dark. Filter before adding to a fresh bath instead of water. If care be taken in the preparation, this toning mixture gives delightful purple-black results, rich in quality and very pleasing. It works easily, and is not liable to double tones. On this account various modifications of this bath are in general use by professionals. It is especially

suitable where large batches of prints are toned.

THIOCARBAMIDE BATH.

Thiocarbamide	5 grs.
Distilled Water	4 oz.

Now make up a solution of chloride of gold, 1 gr. in 1 dr. of distilled water, and add sufficient of it, drop by drop, until the precipitate first formed is redissolved. Then add:—

Citric Acid	2.5 grs.
Distilled Water to	10 oz.

and finally put in about 50 grains of salt. This bath is recommended by Hélain as an improvement on the sulphocyanide bath; and results from it are certainly very beautiful. The tones are very bright, and the high lights delightfully clean, with no trace of pinkiness. In using the bath, the greatest care must be taken to wash the prints thoroughly, both before and after toning, and particularly before fixing. Warm tones are produced by diluting the bath.

PHOSPHATE OF SODA BATH.

Sodium Phosphate	12 grs.
Water	10 oz.
Gold Chloride5 grs.

This is an old bath, and used largely by workers of albumenised paper, but with an increase of phosphate. It can be used when mixed, and gives purple results, particularly free from double tones. Must be thrown away after use, as it will not keep. The phosphate should be used in dry crystals. Toning should be complete in five or six minutes. When used on P.O.P. paper, it gives a tone very closely resembling albumen—that is to say, good pure shadows not in any way clogged.

FORMATE OF SODA BATH.

Sodium Formate	30 grs.
Sodium Carbonate	4 grs.
Water	10 oz.
Gold Chloride	2 grs.

This bath can be used when mixed, care being taken to wash the prints well. It is customary to immerse the prints before toning in common salt 1 part, water 10 parts.

It tones quickly, giving very good browns. Fine warm tones are produced with a diluted bath.

TUNGSTATE OF SODA BATH.

Sodium Tungstate	20 grs.
Water	10 oz.
Gold Chloride	1 gr.

This bath is excellent for warm tones of good quality. Mixing should be done with boiling water. The bath is ready for use when cooled to 60°. It keeps well, and may be used repeatedly, adding 1 oz. of new solution for every sheet of paper toned. Some workers greatly dislike this bath, as in their hands it gives good tones only from the very best negatives.

CHLORIDE OF LIME AND CHALK BATH.

Chloride of Lime	2 grs.
Chalk	20 grs.
Water	10 oz.
Gold Chloride	2 grs.

This bath gives brilliant results, of good purple tones. It should stand for forty-eight hours before using, unless boiling water is used for mixing. It is then ready for use when cooled to 60°. This bath has one serious disadvantage; namely, that it necessitates considerable over-printing, as the colouring matter deposited does not consist entirely of gold, and is dissolved in the hypo. bath. Also, the image suffers considerable loss in vigour. By increasing the proportion of chloride of lime there is less need of over-printing.

COMPOUND CONCENTRATED BATH.

Chloride of Lime	15 grs.
Chalk	15 grs.
Sodium Acetate	60 grs.
Gold Chloride	15 grs.
Water	5 oz.

Dissolve thoroughly, adding the gold chloride in a thin stream, and stirring well. This concentrated bath should be left at least ten days before using, when 1 oz. of solution should be filtered and added to 11 oz. of water. It gives good purple tones with ease from all fairly good negatives, and seems to work better than the acetate.

MAKING-UP THE BATH.

When working on a small scale, the best plan is to make up just sufficient bath to tone the prints in hand. Thus, if 2 grains will tone one sheet of paper to a purple, then for every three half-plates or six quarter-plates it will be necessary to take $\frac{2}{3}$ grains of gold and a proportionate quantity of sulphocyanide. For measuring extremely small quantities of gold, make up the gold into a 1-per-cent. solution by dissolving the 15-gr. tube in 3 oz. 1 dr. of distilled water; every 100 minims will then contain 1 grain. The sulphocyanide may be in a 10-per-cent. solution. Suppose now one half-plate or its equivalent is to be toned. Take 25 minims of sulphocyanide solution, and add to it sufficient water to deal conveniently with the print. Then add 12 minims of the 1-per-cent. solution of gold chloride. Any larger number of prints will require quantities of each in the same proportion, the amount being easily ascertained by multiplying the numbers just given.

PROPORTION OF GOLD FOR DIFFERENT TONES.

It has already been stated that the proportion of gold to the area of the paper governs the final tone. The following table shows the exact proportion necessary for toning one quarter-plate print:

Gold Chloride.	Tone.
8 minims or $\frac{2}{15}$ ths of a grain.	Purple black
4 .. $\frac{1}{15}$..	Purple
3 .. $\frac{2}{15}$..	Brown
2 .. $\frac{1}{15}$..	Warm brown
1 minim or $\frac{1}{15}$ th ..	Red

It is assumed that a 1-per-cent. solution of gold chloride is in use. If also a 10-per-cent. solution of ammonium sulphocyanide is employed, the same number of minims of this may be taken, and the solution made up with sufficient water for the number of prints in hand.

PLATINUM TONING FOR P.O.P. AND COLLODIO-CHLORIDE PAPERS.

This metal is very little used for the glossy varieties, the tones given being more suitable for matt surface papers.

Some really fine results can be produced, the tones being quite peculiar to platinum, and, generally speaking, cannot be given by baths made up of other metals. It must not be supposed that platinum is especially suitable for good black tones. The quality of a black tone produced with gelatino-chloride prints is, generally speaking, not to be compared to the rich velvet black of platinum papers, or even gelatino-bromide papers. In fact, platinum gives warm brown and sepia tones, the latter tints being very useful, and showing to great advantage for some subjects. The prints should, except for the difference of the bath, be treated exactly as for gold toning; save that the prints, after leaving the platinum bath, should be immediately transferred to a 5-per-cent. solution of common salt. Otherwise, toning continues while washing, and uniform results cannot be relied upon.

THE PLATINUM BATH.

Chloro-platinite of potassium is the salt employed; it may be procured in 15 grain tubes like gold chloride. Several formulæ for platinum baths have been suggested, those given below having been tested and found to work well with the matt papers in general use.

Sodium Chloride (Common Salt)	. 50 grs.
Alum	. 100 grs.
Chloro-platinite of Potassium	. 2 grs.
Water	. 10 oz.

With this bath, brown tones will be produced in about five minutes, sepia tones in ten minutes. It is not advisable to take the prints further than sepia, as the colour becomes unsatisfactory. If removed from the bath after two minutes only, the finished prints will be red-brown, and will be found an artistic shade for portraiture and special effects. It is not necessary that prints toned in this bath should be alumed after the first washing. The free salts, however, must be thoroughly eliminated. The prints will dry decidedly colder in tone than they appear when wet, and this must be allowed for.

ANOTHER FORMULA.

Potassium Chloro-platinite	8 grs.
Dilute Phosphoric Acid	2 drams.
Water	10 oz.

Proceed with this bath as usual, not neglecting the salt and alum bath before toning. A diluted bath will give warm sepia tones more easily.

HADDON'S FORMULA.

Platinum perchloride is not especially suitable for toning, although the following formula yields very pleasing prints:—

Platinum Perchloride	3 grs.
Sodium Formate	100 grs.
Formic Acid	30 min.
Water	35 oz.

A formula sometimes given for black tones is:—

Sodium Chloride (Salt)	100 grs.
Sodium Bicarbonate	40 grs.
Water	10 oz.

The prints are placed direct into this bath. After washing, they are toned to purple red in:—

Borax	40 grs.
Gold Chloride	1 gr.
Water	15 oz.

and, finally, washed and toned to black in the phosphoric platinum bath. This method cannot be recommended for black tones, although some workers find it answers remarkably well. Careful washing is very essential between each stage. The prints must be kept moving, and well separated when toning. The final tone must be judged by transmitted light.

ANOTHER METHOD

which is now employed with matt paper in a large printing factory is as follows: Dissolve 4 oz. of borax in 8 oz. of water, and for use take 1 part of this and dilute with 5 parts of water. The tone should be governed by the amount of gold per area treated. Thus, for a blue-black tone, use 3 grains per sheet, or for a red tone the minimum quantity of $\frac{1}{2}$ grain per sheet. The prints are then toned in the platinum bath as given above, except that it is the rule to use it slightly more dilute and to strengthen it as required.

ALBUMENISED PAPER.

A particular feature of this paper is that it is not nearly so liable to double toning as gelatino-chloride paper. Toning, as a rule, is more even, and purple colours are very readily obtained. The paper should be quite fresh, and no time should be lost after printing before finishing. Keep the prints well protected in a box, or between the leaves of a blotting book. In no case should the time between printing and toning exceed two or three days.

PERMANENCY.

Much blame is laid to the charge of this paper on account of the vast number of albumen prints which are liable to rapid fading; but if the paper is well made, and precautions taken, especially in the washing between the different stages of toning and fixing, there seems to be no reason why albumen prints should not be at least as permanent as any print-out silver prints. The proper elimination of all free soluble salts is the important point to be remembered. Most of the P.O.P. toning formulae give good results on albumen paper, and the general instructions are the same.

TONING BATHS FOR ALBUMENISED PAPER.

Acetate of Soda	30 grs.
Water	10 oz.
Gold Chloride	1 gr.

Mix with hot water, and use twenty-four hours after. The bath acts regularly, and produces warm, rich tones. It will keep, and if stored carefully the old bath may be used to dilute fresh solutions. Good tones should be procured in about seven minutes. The above formula is the one commonly used by professional workers who sensitise their own paper. The following bath was for many years a great favourite with professional users of albumen paper.

Bicarbonate of Soda	4 grs.
Water	10 oz.
Gold Chloride	1 gr.

It is suitable for warm tones, and may be used immediately it is mixed, but must be thrown away after use, as it will not keep.

Phosphate of Soda	20 grs.
Water	10 oz.
Gold Chloride	1 gr.

Suitable for rich purple tones. Must be used immediately it is mixed, as it rapidly deteriorates. Old solutions cannot be used to dilute new baths.

CONCENTRATED BATH.

Chloride of Gold	15 grs.
Water	20 oz.
Chloride of Calcium	2 drams.

To mix this bath, the gold should be first dissolved in 1 or 5 oz. of water; and, if acid, the solution should be neutralised by the addition of a little lime water. The remaining water is then added, and after this the calcium. For use, take 1 oz. of solution to 10 oz. of water. This stock bath will keep well.

ACETATE BATH.

The acetate bath is also very suitable for making up a concentrated solution.

Acetate of Soda	180 grs.
Water	15 oz.
Gold Chloride	15 grs.

1 oz. of this solution added to 20 oz. of water will tone a full sheet of paper, or 30 prints $\frac{1}{4}$ -plate size. This concentrated acetate bath will keep splendidly, and may be used repeatedly, adding fresh solution as required. Large batches of prints can, perhaps, be toned more reliably in this bath than in any other. After toning, the prints simply require rinsing in clean water before placing in the fixing bath.

PAPER TO BE USED.

The above baths are specially suitable for use with paper prepared as described in the section on "Printing-out Processes and Papers" (p. 170); but for those prepared upon an acid sensitising bath, such as what are called "ready sensitised" papers, the borax bath should be employed.

BATH FOR PLAIN SALTED PAPER.

This paper has had to give place to the more reliable commercial papers, gelatino-chloride, collodio-chloride and albumenised; and, except by those who prefer to

make it themselves, is very little used. The enthusiastic worker, however, will find that some beautiful results can be obtained, especially with rough paper, for broad effects. Borax and acetate are the two chief toning baths.

Borax	100 grs.
Hot Water	5 oz.
Gold Chloride	1 gr.
Water	5 oz.

Use this bath immediately after mixing the two solutions, as it will not keep.

ALTERNATIVE BATH FOR PLAIN SALTED PAPER.

Sodium Acetate	30 grs.
Water	10 oz.
Gold Chloride	1 gr.

Make up with hot water, and use when cool. It keeps well, but the old bath should be strengthened from time to time with fresh solution. This bath is not, however, so good as the last named, as there is a tendency towards greyness with it.

FIXING WITHOUT TONING.

As plain salted paper fixes out a very pleasing sepia colour, if not too heavily sized, it may even be better not to tone it at all. This may be explained in the following manner. If paper prepared only with silver chloride is fixed, it comes from the hypo. bath a blue, whilst if the organic silver salt is chiefly used, a foxy red results. Compare an ordinary P.O.P. print with a piece of filter paper sensitised as described in the section on "Printing-out Processes and Papers" (p. 161). It is the combination of these two colours in right proportion which results in a pleasing tone on fixing. Such papers are sometimes termed "self-toning" papers. To produce a satisfactory result, it is essential that all the free silver is removed from the print before fixing.

IMPORTANCE OF THOROUGH WASHING.

Too much emphasis cannot be laid on the fact that thorough removal of all free silver and free platinum salts is essential before passing into the toning or the hypo. bath. It has been proved that chloroplatinite of potassium and silver

citrate form certain insoluble compounds which remain in the paper and are liable to discolour under the action of light; while the same remark applies to the combination of chloroplatinite and hyposulphite. Before any and every toning bath, therefore, washing is necessary to ensure complete removal of the free silver: while, after toning, the prints must pass through an alkaline bath, for platinum toning baths are invariably acid.

FORMULA FOR BLACK TONES.

For toning plain salted proofs to a black or brown black, the formula given by Lionel Clark is excellent, being exceedingly simple and reliable.

Chloroplatinite of potassium	4 grs.
Water	2 oz.
Nitric Acid	2 drops.

(Almost any of the acids may be substituted without apparent difference if in same proportion.) Owing to the costly nature of the solution, he suggests using the reverse side of a wooden dish levelled by three screws to contain the solution (or three wedges may be employed for the same purpose). The print, on coming from the washing water, is floated in this and instantly assumes a brown black. It is then passed into a bath of carbonate of soda, and is ready for fixing. By making use of the above plan the solution may be made to cover an 18 in. by 15 in. dish. This bath does not keep, but may be used to tone several sheets in succession. For warm brown tones it is made up much weaker, diluting even to one quarter the above strength, or $\frac{1}{2}$ grain per oz. Such a bath may, of course, be used in the ordinary manner.

COMBINED TONING AND FIXING BATH.

Much has been written with reference to this method of finishing prints, particularly regarding permanency. It has been urged in its favour that the bringing of the print in contact with the salts contained in ordinary water is liable to cause the precipitation of compounds within the print which will subsequently react upon it; and that, as the combined bath allows of toning without the prelimin-

ary removal of the free silver nitrate, such a bath possesses the advantage of giving greater permanency to the print. On the other hand, it has been proved that if a solution of alum is added to a solution of sodium thiosulphate, sulphur is liberated, and this sulphur is bound to attack the image, with consequent fading. Moreover, the toning is usually complete before the print is properly fixed, so that even if the injurious compounds, alum and lead nitrate, are omitted, a second fixing is required. The abolition of one operation is the strong inducement that the combined bath offers, but if a second fixing is needed, the advantage is not evident. On the one hand there is a certainty, and on the other hand there is merely a probability, of the formation of injurious compounds. The prints produced by both methods fade, especially if kept in a strong light and in an impure atmosphere.

POINTS TO BE CONSIDERED.

These are especially the proper elimination of the free salts of silver and acid, and also the complete fixation of the image. Several formulæ have been proposed, in using which no washing before toning is required; that is to say, the dry prints are placed direct into the toning and fixing bath. This, however, is liable to cause intricate chemical combinations, sulphate of aluminium, acid sulphite of soda, pentathionate of soda, sulphuretted hydrogen, besides the free silver and gold salts, being present. It is not difficult to see that deposits of sulphur would very likely affect the permanency of the toned image.

STABILITY OF THE PRINTS.

This is much greater, when the combined bath is used, if the washings are done carefully, and the proper fixing of the image is assured. On the other hand, Mr. Otto Schölzig considers the dangers of fading are increased by the preliminary washing owing to the complex reactions liable to occur when free silver nitrate is brought into contact with the soluble salts present in ordinary tap water. He based these conclusions upon the following ex-

perments. An unexposed piece of albumenised paper was taken and cut into two pieces. Both pieces were washed for ten minutes, and then one piece was soaked for a further ten minutes in a new toning bath, and finally both were fixed in the usual hypo. bath, washed, and dried. A few drops of ammonium sulphide were then added to a little water, and both papers soaked in it, when it was found that the piece which was untoned was unaffected, but the piece which had been through the toning bath showed a decided yellowing of the whites through the formation of silver sulphide. From this it was assumed that the deposition of the gold imprisoned certain compounds formed by the washing water, which were not so readily removed as a consequence. This, however, does not appear to be the case with all samples of water; but the experiment is certainly worth repeating. Mr. Schölzig has also suggested that the exact amount of gold required to tone each print should be taken, and applied with a brush. This method is, of course, far too slow for commercial work.

RINSING AND FINISHING.

With all combined baths, the tendency is for the toning to be completed before fixing is finished. The prints should, therefore, be rinsed and fixed for five minutes in a fresh solution of hypo. or other fixing agent. In some respects, if the prints are placed direct into the toning and fixing baths given, the results appear to be superior. This cannot, however, be recommended on account of the danger of sulphur toning, as previously stated. Wash the prints in several changes, both before and after toning.

GOLD COMBINED BATH.

Ammonium Sulphocyanide	200 grs.
Sodium Chloride (Common Salt)	200 grs.
Alum (Powdered)	100 grs.
Hypo-sulphite of Soda	1½ oz.
Water (Distilled)	10 oz.

When mixed, allow to stand for two or three days. Pour off the clear solution, and add

Gold Chloride	4 grs.
Water	½ oz.

The following bath is more complicated, but gives pleasing tones.

Lead Acetate	30 grs.
Sodium Acetate	10 grs.
Hypo-sulphite of Soda	1 oz.
Sodium Carbonate	10 grs.
Alum (Powdered)	30 grs.
Gold Chloride	1 gr.
Water up to	10 oz.

Add each ingredient to the water, in the order given; and allow to stand at least twenty-four hours before use. Filter the solution.

PLATINUM COMBINED BATH.

Hypo	1 oz.
Lead Nitrate	60 grs.
Alum	60 grs.
Sodium Formate	20 grs.
Formic Acid	30 grs.
Water	10 oz.

Dissolve the lead and sodium formate in 2 oz. of water; then add to this the hypo. and alum, which should have been dissolved in the remaining 8 oz. of water (hot). Leave the mixture standing in an open vessel for twenty-four hours, and then add

Platinum Bichloride	2 grs.
-------------------------------	--------

PRELIMINARY WASHING.

Before toning, wash the prints well and soak in

Sodium Chloride	½ oz.
Water	10 oz.

The washing of prints after toning should be thorough, and generally ten minutes in several changes will suffice. It is important that all trace of toning solution be removed, as it would cause the fixing bath to become acid, which is most certainly undesirable. See that the prints are kept free during washing. If they are allowed to cling together, stains will afterwards appear.

FIXING SILVER PRINTS.

By fixing is meant the removal of any sensitive silver salts which have not been acted upon by light. Until this stage is reached, the prints must have been protected from actinic light as far as possible to avoid degraded tones. These salts are

removed by the solvent action of hyposulphite of soda, cyanide of potassium, and sulphite of soda. Of these, the first named is almost universally used. It is in the form of watery crystals, and must not be contaminated by acid. When hypo. is dissolved in water, it has a cooling action. It is advisable, therefore, to make up hypo. solutions with warm water, since, if the fixing bath is cold, the action is retarded and irregular. This, and all other baths used in the toning process, should be worked at about 60°.

real soda hyposulphite— $\text{Na}_2 \text{HSO}_2$ —being a substance containing less oxygen and sulphur, and useless for fixing) are first to form silver hyposulphite, and, at the same instant, the double salt of silver and soda hyposulphite, which is insoluble in water but soluble in excess of hypo., so that a further reaction goes on, provided the solution is strong enough. To ensure proper fixing, the bath must therefore be of sufficient strength. On the other hand, too strong a bath is liable to partially dissolve away the image. It has been

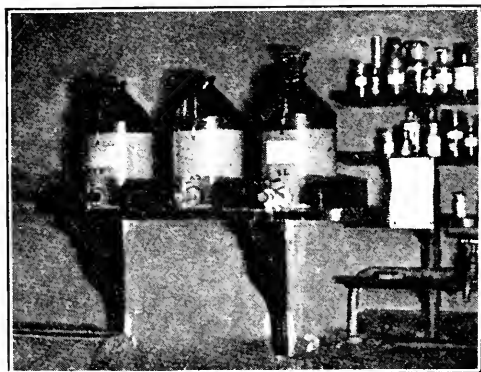

Fig. 346.—ARRANGEMENT FOR HOLDING STOCK SOLUTIONS.

FIXING BATH

Hypo.	3 oz.
Water	20 oz.

This bath is recommended as the best strength for most silver prints. In case the hypo. is not quite free from acid, a few drops of liquid ammonia or a few grains of sodium carbonate should be added to the baths, sufficient only to give an alkaline reaction with litmus paper. Acid fixing baths are sometimes used for bromide prints, but on no account should they be employed with printing-out paper. A mixture of hypo., alum, and citric acid works very cleanly and brightly, but it cannot be relied upon if permanence is a consideration. In the opinion of many, an alkaline fixing bath should be invariably used. The reactions which occur when silver chloride is placed in soda hyposulphite (or, more correctly, soda thiosulphate— $\text{Na}_2 \text{S}_2 \text{O}_3 + 5 \text{H}_2 \text{O}$ —the



Fig. 347.—MAKING STOCK SOLUTION OF HYPO.

stated that a 10 per cent. bath of hypo. can thoroughly fix a print in ten minutes; while, as to quantity, the minimum amount allowable would be 2 oz. of the above solution to each dozen half-plate prints. Freshly made hypo. solution must be used for papers; but the same fixing bath may be used repeatedly for plates without apparently much harm arising. Nevertheless, in all cases it is advisable to have fixing solutions as fresh as possible.

PREPARATION OF SODIUM THIOSULPHATE.

The quality and form of the salt used are matters requiring attention. Rough lumps covered with metallic and other impurities, such as are supplied by some

chemists, should never be used for fixing prints, or all kinds of spots and markings may be expected. The granulated form is the best, and the crystals must be clear and clean. Ordinary hypo. contains 5 molecules of water (see above: the anhydrous form is scarcely ever used for photography), and dissolves readily, but being heavier than the water it requires thorough mixing, or the hypo. will remain at the bottom of the vessel. It has already been pointed out that hot water must be used, so that the following will be the exact procedure. Place the crystals in a large stone jar, or barrel, and pour the hot water over. Stir well till dissolved, then add cold water to make a 1 in 3 solution (*i.e.*, 1 oz. in every 3 oz.). The amount needed is drawn off, as required.

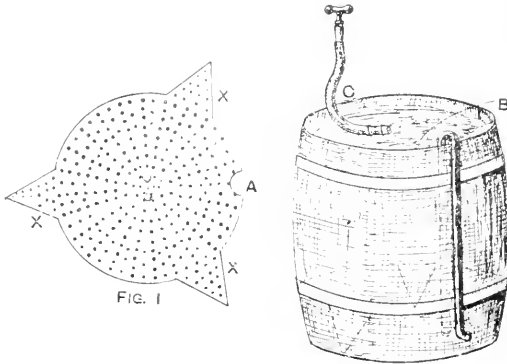

Fig. 348.—PERFORATED ZINC FOR PRINT WASHER.

Fig. 349.—BARREL PRINT WASHER.

from this stock solution, and may be used as it is for plates, or diluted with an equal bulk of water for prints. Fig. 346 shows a good form of appliance. Some workers prefer to use a contrivance something like a colander, in which the crystals are placed, and the hot water poured over, as in Fig. 347. An arrangement for upward filtration, as described in the section on "Printing-out Processes and Papers" (p. 168), may be used; substituting, of course, a piece of canvas or netting for the muslin. The crystals, if preferred, may be suspended in a muslin bag. Do not make up the hypo. bath just before toning; in fact, it is better not to touch it at all if it can be avoided.

ADDITIONS TO THE BATH.

The principal additions to the bath which have been suggested are sodium sulphite and soda carbonate; both serve to keep the bath faintly alkaline. The following formula may be used:

Hypo.	5 oz.
Common Salt	$\frac{1}{2}$ oz.
Soda Sulphite	$\frac{1}{2}$ oz.
Water	20 oz.

Or, in the case of soda carbonate, use sufficient only to render faintly alkaline.

ADDITIONAL FIXING BATHS.

It is always a good plan to have two baths ready: so that when all the prints have been passed into No. 1 bath, those that were placed there first may be transferred to No. 2. This ensures proper fixation, and prevents overcrowding. In the case of the combined bath, it is also a

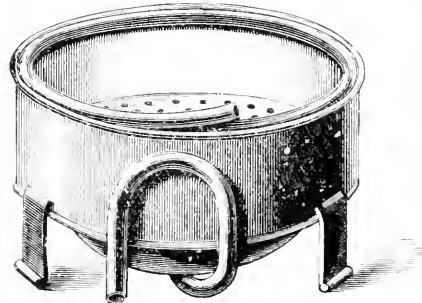

Fig. 350.—CIRCULAR WASHING TANK.

good plan to have an additional fixing bath, since it is seldom that the prints can be sure of proper fixation in the same time as that taken for toning. In the case of toning, the time of immersion may be varied according to the colour desired; but in fixing it must always continue until the effect is complete. If the solution is too weak, a salt of silver-hyposulphite is formed, insoluble in water. This is probably the most fruitful cause of fading and deterioration. A fresh bath should, therefore, be used for each batch of prints. Hypo. is extremely cheap, and it is poor economy to use old baths which are weakened by use and contain silver. If the bath has been used even once before there is always great danger of stained lights.

METHOD OF FIXING.

To ensure perfect fixing, the prints must not be allowed simply to soak in the bath, but should be regularly moved about one by one; the best plan being to have two dishes and plenty of solution. The prints should be removed from one dish to the other constantly, pressing each one under the surface. If only one dish is used, the prints must be moved about in a systematic manner to ensure each one being properly exposed to the working of the bath. Ten minutes should suffice for complete fixation, when a fresh bath is used. Prolonged immersion tends to reduce the

is finished, or at some future time. The best method of hand washing is by using two dishes of clean water placed side by side. Laying the prints all in one dish, transfer one at a time, draining well, to dish No. 2. Pour away dish No. 1, and refill with clean water. This process, which must be continued for twenty minutes, is rendered still more effective if each print is laid on a glass and stroked lightly on the back with a squeegee. This somewhat tedious method of washing is, however, far from convenient to those who do a lot of

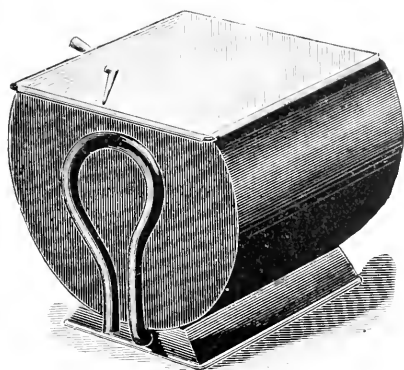

Fig. 351.—WASHING APPARATUS.

image and destroy brilliancy; but at least ten minutes should be given. It is at this point that the permanency of the picture is most likely to be affected.

FINAL WASHING

Nothing must be left in the print except the metallic particles which form the image; and the hypo. having removed all the soluble silver salts, it must, in its turn, be entirely eliminated. Prolonged washing and soaking is the best means of accomplishing this. The water and the prints should be kept constantly moving; while the fact that the hypo. is not simply on the surface, but embedded in the film and paper, makes a slow process of thorough soaking necessary. The slightest traces of hypo. left in the print will cause spots and stains, either when the picture

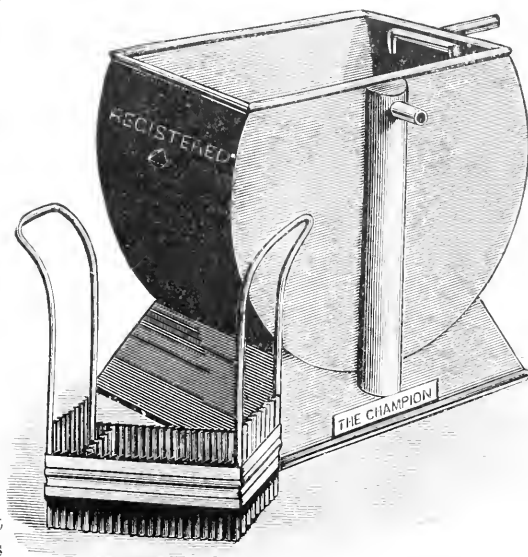

Fig. 352.—WASHER FOR PRINTS OR NEGATIVES.

work, and several machines have been devised for the purpose.

MECHANICAL WASHERS.

It has been pointed out that, when possible, hand washing is preferable to machine washing; but it will easily be seen that hand washing can only be done when the quantity dealt with is small, as not more than about fifty prints can be washed properly by hand at one time, and if they have to be done in batches the waste of time increases. All washers are constructed on practically the same principle. They consist of two compartments, and are made of a substance that is not likely to

affect the print, such as wood, enamelled metal, or porcelain; the lower compartment receives the contaminated water, and is fitted with a syphon for emptying purposes, and the upper compartment allows the prints to soak, keeping them at the same time well separated. Any washer that does not meet these requirements is bad. A serviceable washer may be constructed with a small wooden cask, a sheet of perforated zinc, some compo piping, and some rubber tubing. Coat the cask well, inside and out, with paraffin wax. Next cut a sheet of perforated zinc, as shown in Fig. 348, bend at the parts marked x, and place the zinc in the bottom of the cask. The zinc can be removed when required by

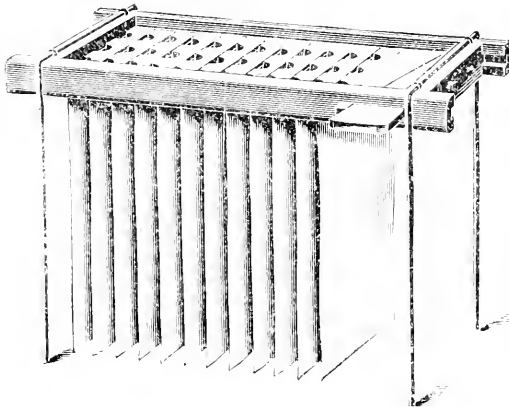

Fig. 353.—SUSPENSION WASHING APPARATUS.

passing the fingers through the two holes. The compo piping must be fastened so as to pass through the cut a and over the side (see B, Fig. 349). At c fix another piece of piping and connect c with the tap by a piece of rubber tubing. A circular motion is given to the prints by the jet of water emitted by c. Fig. 350 shows an excellent form of washing apparatus. The fresh water is introduced from the side, and the contaminated water is drawn off from the bottom. The inventor claims that in all ordinary circumstances it is impossible for prints to clog together for a moment, and this claim seems to be substantiated. The prints do not appear to suffer ill usage in the process, as with

some mechanical washers. Fig. 351 shows another form of washer which is very popular. The "Champion," suitable for either prints or negatives, is illustrated by Fig. 352. The "Suspension" washer for large prints is shown by Fig. 353. The prints are held in a wooden frame by means of wedges and the frame is supported in a large tub or tank by metal uprights, which fold out of the way when not in use. Another useful idea takes the form of wooden clips (Fig. 354) by means of which the prints may be floated in an upright position in any convenient vessel.

OTHER SUBSTANCES USED IN TONING.

Other substances have been suggested for toning, among which are uranium, palladium, lead, osmium, and iridium. Of these, uranium is dealt with in another section, and is not by any means suitable for toning print-out impressions. Prints may, however, sometimes be toned in a mixture of gold and uranium with some success. The formula used is:

Chloride of Gold	1 gr.
Uranium Nitrate	1 gr.
Sodium Acetate	15 grs.
Common Salt	15 grs.
Water	10 oz.

Pleasing dark tones are obtainable, but the image loses considerably in vigour. Palladium toning does not appear to offer any advantages over the usual and more accessible substances. The following formula has, however, been experimented with:

Chloro-palladinite of Potassium	2 grs.
Citric Acid	20 grs.
Water	10 oz.

20 grains of common salt may be added, if desired, but it does not appear to affect the result materially. The addition of common salt to platinum and other toning baths has been many times suggested. It certainly offers the advantage of ensuring the conversion of any free silver remaining in the paper, and preventing its combination with the platinum or other salt, but it appears to retard the toning action seriously, and, in fact, in some cases stops it altogether.



FULL FACE ORDINARY ROUND LIGHTING.



THREE-QUARTER FACE TURNED TOWARDS LIGHT

EXAMPLES OF STUDIO LIGHTING.

CAUSES OF FAILURE.

Great importance attaches to the thoroughness with which the different operations are carried out, especially when washing the prints between the alum and gold baths, and also before and after fixing. Most of the defects met with, such as stained or spotty prints, uneven and poor tones, etc., are generally traceable to faulty working and failure to carry out the instructions in their entirety. Of course, chemicals are sometimes impure, and the prepared paper is occasionally at fault, but as a rule both chemicals and paper are of excellent and reliable quality. Iron spots and markings sometimes appear on the paper, having escaped the vigilant eye of the factory examiner; but such faults are not common, and should be detected before printing. It is proposed, therefore, to consider the common causes of failure, with special reference to stains and poor quality of tone.

STAINS.

Many photographic experts have made this the subject of research, and the experiments of Mr. C. H. Bothamley a few years ago did a very great deal towards clearing up some disputed points. Among other things, he pointed out the absolute necessity of excluding hypo. from all operations before fixing. Until this stage is reached, the hypo. should be placed entirely on one side. A certain part of the working room should be set apart for the hypo. dishes, and used for nothing else. Do not make up solutions of hypo. near the toning bench; in fact, no trace of solutions or crystals should be allowed where other work is done. See that the hands are well washed after manipulating the prints while fixing, and not merely dried with a towel. This is a frequent cause of bad stains; the towel appears clean, but is really affected sufficiently to contaminate the fingers instead of cleansing them. Even though great care is used to thoroughly wash down a bench that has been splashed with hypo., some part will probably be absorbed in the wood, and at some future time will work mischief.

HOW TO TREAT HYPO. STAINS.

To the novice it is always a cause of considerable wonderment why a print may be placed entirely in a bath of hypo. without staining, and yet if touched by the hand which has been in contact with the merest trace of the salt a bad stain is produced. This is easily explained by a little experiment. Take a small quantity of silver chloride and divide it into two parts, placing each portion in a test tube. Pour over one a strong hypo. bath, say 3 in 20, and a weak one, 1 in 200, over the other. That in the strong hypo. bath will be immediately dissolved, but the other will form a dirty yellow metallic-looking precipitate. This is the insoluble silver thiosulphate, which rapidly decomposes into the dirty brown silver sulphide, constituting the stain on the paper. In most cases the stain is complicated by the silver organate present. Such stains

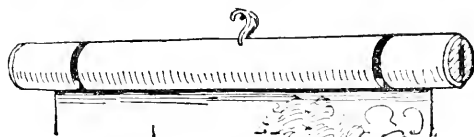

Fig. 354.—FLOATING PRINT CLIP.

are to some extent soluble or removable by strong potassium cyanide, but it needs to be used with extreme care, and, generally speaking, it is easier and better to make a new print. The method adopted is to moisten the corner of a silk handkerchief and rub it on a lump of potassium cyanide, and then lightly touch the stain until it shows signs of disappearing, when it may be plunged into a bath of clean water.

POOR TONES

may usually be traced to prints from flat negatives with very little contrast. In the case of an average negative, however, should poor tones be produced, one of three things may have a bearing on the result: (a) Printing in too bright a light, and consequently destroying the proper contrast of light and shade; (b) toning in too strong a bath; (c) toning in an old or weak bath. The remedy for (a) is obvious. For (b) the time taken for toning should be

noted. This, under ordinary conditions, at a temperature of, say, 60° F., should take from 6 to 8 minutes. If the toning is completed in less time, the bath is too strong for the best work. In the case of (c), an old or weak bath will invariably affect the tone, for the reason that the gold is either used up in toning or has been precipitated by impurities in the water, action of light, etc. Great care should be taken that the proportions of gold and salt are maintained, or the toning will be irregular.

DOUBLE TONING

is generally the result of using a weak bath, which is strong enough to tone the lighter half-tones but fails to affect the stronger portions of the print. Especially is this the case with the sulphocyanide bath. Excess of this salt is liable to produce double tones and pinkness. Therefore it is better, when working on a small scale, to make up a fresh bath for the exact number of prints—for instance, a 10 oz. bath for each dozen quarter-plates—than to strengthen a bath that has been used by the addition of sulphocyanide and gold.

LOSS OF TONE IN FIXING

may be caused by (a) too strong a toning bath, or (b) too strong a fixing bath. If the bath is too strong, the tone is more or less superficial, giving consequently a thin image after removal of the free silver salts by the fixer. When the fixing bath is too strong, a similar result happens in a different way, the whole image being reduced. A bath of a certain strength should be invariably used for a certain number of prints. A 20 oz. bath of hypo. solution (3

in 20) is sufficient to fix safely about 50 cabinet prints, each remaining in the bath 10 minutes. Use a fresh bath for each batch of prints.

CONCLUDING HINTS.

General faults in toning may be found to be the result of the prints sticking together, or adhering to the sides of the dish. In all operations the prints must be kept moving, however slowly, so that the solutions shall have free access to the surface of the print. Very many difficulties may result from negligence in this respect, particularly stains and marks. Bleached spots on prints, which have a bluish tinge, and appear in the final washing, are usually due to allowing the prints to cling together in the washing tank. Loss of brilliancy is also caused by prolonged washing, which makes the film tender and the paper rotten. Prints which have been washed too long are almost as likely to fade as those which have not been washed long enough. Black spots are sometimes due to faults in manufacture; in this case they may be detected before printing, but will, of course, appear lighter and brighter. Generally, black spots are traceable to metallic impurities in the washing water. Iron rust from old pipes is a constant source of the trouble. Such operations as filing, cleaning up brass-work, etc., should not be done when the prints are about drying, and never in a printing room. If yellow whites appear during the operation they are due to (a) a trace of hypo. in the washing water, or (b) an old or stained fixing bath. If the defect does not show until after drying and exposure to light, insufficient fixing is the cause.

THE DARK-ROOM AND ITS FITTINGS.

INTRODUCTION.

A PROPERLY arranged and well equipped dark-room is one of the essentials of successful photography. Some workers manage with a minimum of space and few appliances; but the best work is possible only when carried out in a dark-room fitted up to meet every requirement of the operator. To pay no attention to order and method is simply to multiply trouble; and while it is not within the power of all to obtain the necessary space for a model dark-room, a little planning and contriving beforehand will go a long way towards providing a suitable substitute. This section, therefore, will deal with the construction and fitting-up of the dark-room, the appliances required, and other matters of interest to both the amateur and the professional.

PLANNING THE DARK-ROOM.

It is advisable, before any attempt is made to fit up the dark-room, to draw a rough plan, showing the arrangement of all the benches and shelves in accordance with the shape of the room and the space at disposal. By doing this the maximum amount of space and convenience will be secured, and errors of construction avoided, which otherwise are almost sure to occur. In the case of a small dark-room, for an amateur, freedom of movement is a prime necessity, and careful attention should be given to securing a large, unobstructed bench, with good sink accommodation. The space under the bench is utilised for the provision of racks to hold the dishes, small cupboards, shelves, etc.; while over the bench, at such a height as not to interfere with the

movements of the operator, tiers of shelves are arranged for chemicals and solutions. A common mistake made by amateurs in fitting up a dark-room is to fix the shelves and cupboards first, leaving an insufficient space for working; but if the plan described above is adopted, this is not likely to occur.

PROFESSIONAL DARK-ROOMS.

The dark-room intended for professional use, even when on a large scale, does not differ greatly from that of the well-equipped amateur, except as regards its greater size and the multiplication of detail. When intended for several operators, the developing sinks should be kept at a sufficient distance from each other, and the shelves and cupboards properly divided, to prevent confusion. Greater attention will have to be paid to ventilation where several operators are working together. A floor-covering of continuous removable wooden grating, of the kind seen in tramway cars, will minimise the effect of the inevitable "slopping" which occurs where a considerable quantity of work is done. The water supply will have to be carefully planned, and special provision in the way of tanks, racks, etc., must be made for washing and drying large numbers of negatives.

PORTABLE DARK-ROOMS,

for the benefit of those who cannot obtain the exclusive use of a room for developing, are supplied in a number of excellent patterns. Some of these, such as that shown by Fig. 355, may be readily erected in any ordinary room, and taken down in a few minutes. Another of a more per-

manent character, also suitable for erection in an ordinary apartment, is shown by Fig. 356. Two patterns of outdoor dark-rooms, intended for fitting up in gardens or other open spaces, are illustrated by Figs. 357 and 358.

MAKING A PORTABLE DARK-ROOM.

With a little contrivance a very efficient portable dark-room may be put together. In its simplest form, it consists merely of a large box with a heavy curtain across the

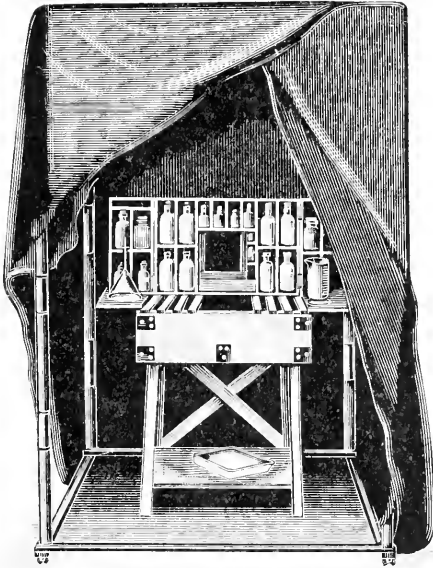

Fig. 355.—PORTABLE DARK-ROOM.

entrance, suitable provision being made for ventilation. All the fittings must, of course, be detachable. Fig. 359 represents a part vertical section through the side of the dark-room containing the window, and the fittings are simply a series of shelves for holding bottles, scales, racks, etc., the shelves being supported by bearers screwed to the sides. The shelf under the window has a box let in, for the reception of a small porcelain sink, 18 in. by 12 in., a pipe leading down to a waste-pail. The shelf above the window supports a small tank holding about 8 gal. and fitted with a pipe and tap.

AN IMPROVISED DARK-ROOM.

As a rule the amateur has to improvise a dark-room by blocking out the light from the windows of an ordinary apartment. This is effected by making a wooden shutter to fit the frame of the window; an opening about 21 in. by 18 in., a little above the level of the table or sink, should be left lengthways, to be covered with ruby fabric or orange paper.

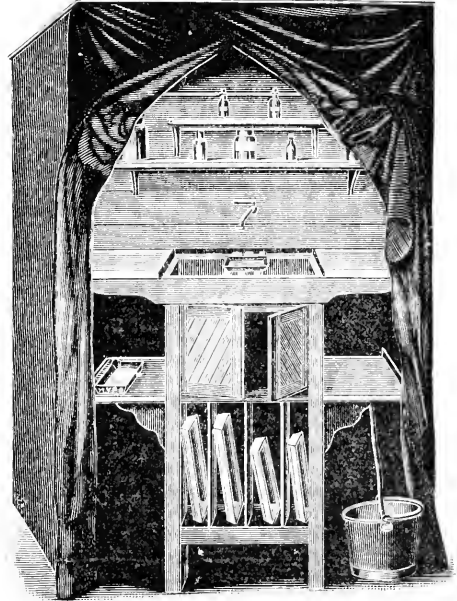

Fig. 356.—PORTABLE DARK-ROOM WITH FIXED BENCH.

The other window (if there is a second one) may be treated in a like manner, except that there should be no opening in the shutter. If possible, have two frames running in grooves and covering the opening in the shutter, the first carrying ruby fabric and the second orange paper. Other methods of attaining the same end will suggest themselves. When using slow plates, or when the light is dull, the orange may be used alone. With rapid plates use both, and always the ruby fabric for isochromatic plates. Two cans or buckets under the table must be provided, unless the water is laid on. The bottles of solu-

tion, dishes, etc., should be on a shelf within easy reach, and the operating table should be kept as clear as possible. The door of the room should have a fastening inside, and a thick curtain should be hung over it. A fairly large cellar will often make a good dark-room, provided that proper means are adopted for ventilation.

VENTILATION OF CELLAR DARK-ROOM.

The best means of ventilating a cellar used as a dark-room, the door of which

the door to allow of the free passage of air into the cellar. If the door affords the only means of communication with the outer air, ventilation by natural methods will be so sluggish as to be practically

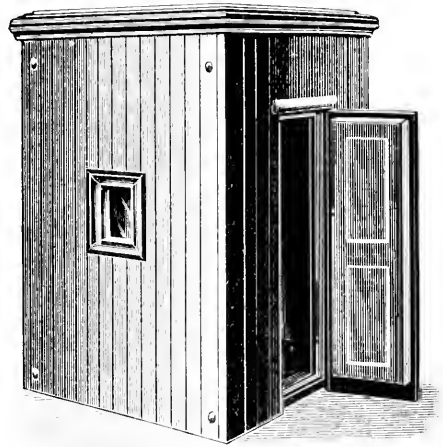

Fig. 358.—OUTDOOR DARK-ROOM WITH FLAT ROOF.

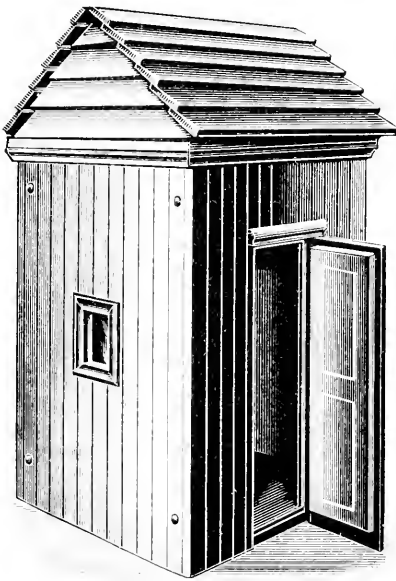

Fig. 357.—OUTDOOR DARK-ROOM WITH GABLE ROOF.

affords the only means of communication with the outer air, is to make a light trap, and, removing a portion of the top of the door H (Fig. 360), fit the trap over the opening, and thus ventilate through the door itself. The light trap is simple and easily made. A cross section is shown by the sketch, which consists of a framework A, with opening at B and C. Shelves placed at E, F, and G form a trap for the light. The interior of the trap is painted black, so that stray light is absorbed, whilst the air can pass readily in the direction indicated by the arrows. A similar trap should be placed at the bottom of

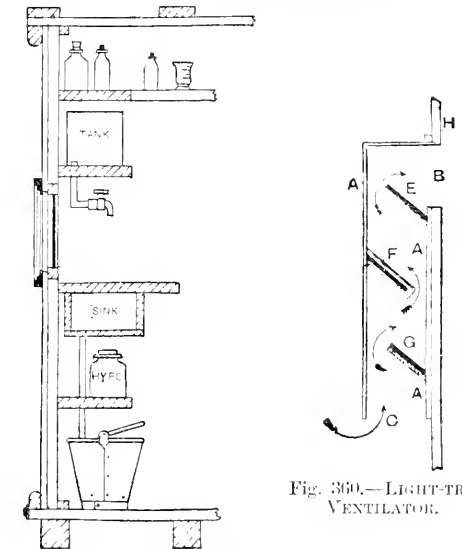

Fig. 360.—LIGHT-TRAP VENTILATOR.

Fig. 359.—FITTINGS OF PORTABLE DARK-ROOM.

useless. Artificial ventilation can be effected either by driving fresh air into the cellar and providing an exit for foul air, or by withdrawing foul air and providing an inlet for fresh.

HEATING ARRANGEMENTS.

It is of great importance that the dark-room should be kept at an equable temperature during cold weather, or the developer will be slow and unsatisfactory in action. This may be overcome to some extent by mixing the various solutions with warm water; but such a makeshift proceeding is not recommended. By a judicious flue arrangement, the dark-room lamp may be made to give the necessary heat, or a small oil or gas stove may be

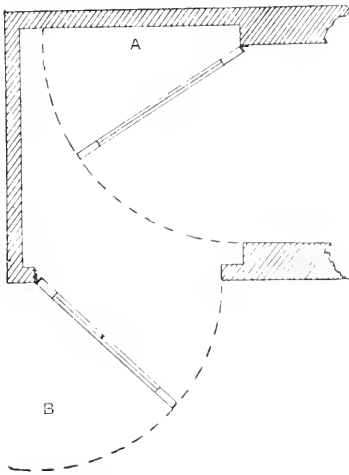

Fig. 361.—DOUBLE LIGHT-TRAP DOOR.

fixed in a suitable position, actinic light being first blocked out. It is possible, in large establishments, to secure uniform heating by means of hot-air pipes. In such cases they may with advantage be kept in proximity to the water pipes, thus tending to prevent freezing and bursting of the latter in wintry weather. Warmth must not be obtained at the expense of ventilation, which should always be carefully attended to, no matter what the temperature may be.

VENTILATORS.

Too little attention is paid by photographers to the ventilation and illumination of the dark-room. Many persons remain shut up for long periods in a room lighted only with a ruby or yellow light,

and without proper ventilation, and suffer in health in consequence. It is not always sufficient to secure a simple entrance and exit for the air. Some mechanical means of keeping the air in motion will sometimes be necessary. For this purpose, nothing could be better than an electric fan; or a satisfactory clockwork substitute might with a little ingenuity be devised. As a rule, however, the ordinary light-trap arrangement previously mentioned will be

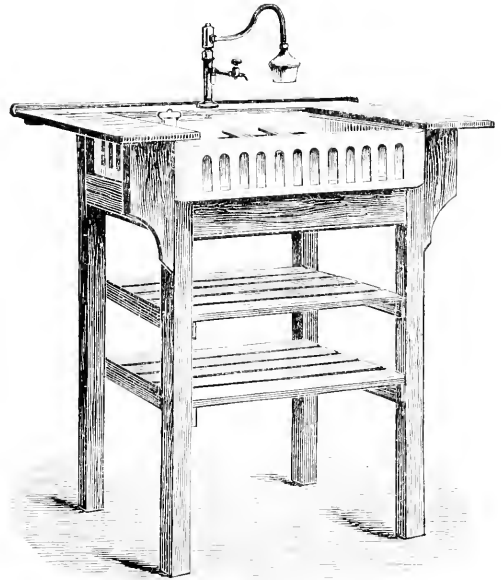

Fig. 362.—PORTABLE DARK-ROOM SINK.

all that is required; or a few perforated zinc gratings may be inserted in convenient places, the light being blocked out in the same way.

LIGHT-TRAP DOORS.

For most purposes, a thick curtain hung outside the dark-room door is sufficient to prevent the entrance of light; but where much passing in and out takes place, a double light-trap door is desirable. The construction of this double door is shown by the plan in Fig. 361, where A and B are the two doors, the dotted curves indicating their movement. It is not absolutely necessary that they should be at right-angles to each other, as shown, so long as

one can be opened and shut without interfering with the other. A double curtain may be made to answer the same purpose, but doors are more satisfactory.

FITTING UP A DARK-ROOM.—WATER SUPPLY.

Although a large apartment has manifest advantages, one of moderate size is

water-pipe. Failing this, a permanently fixed lead-lined sink should be fitted, of such a height that the operator may work with comfort, either sitting or standing. It is as well to have the sink as large as possible: 24 in. by 18 in. by about 8 in. deep is a useful size for amateur work. A wooden grating should be provided for supporting the dishes, etc.

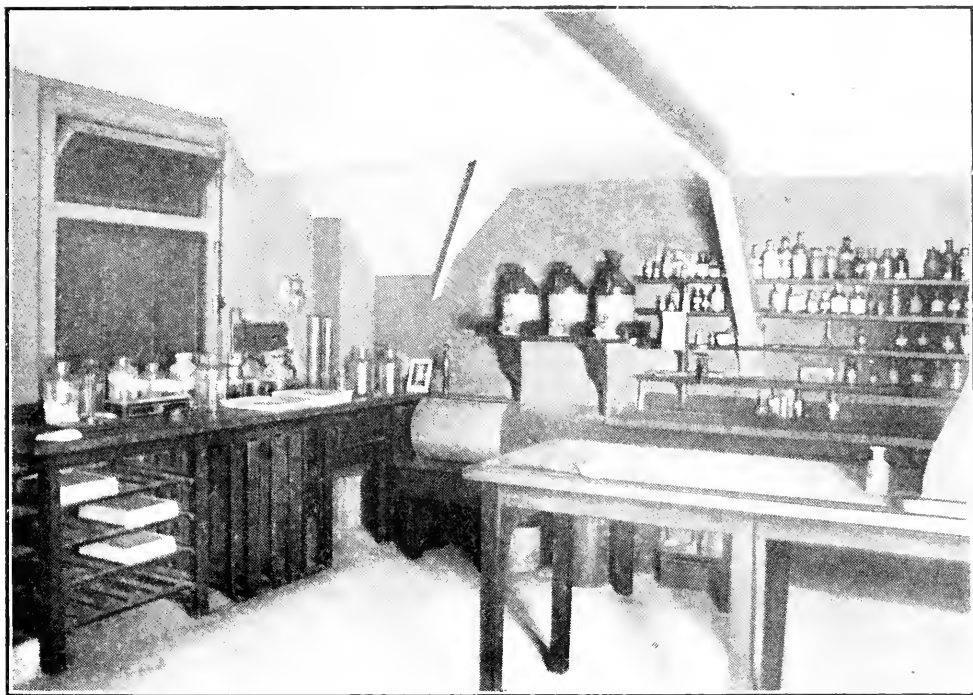

Fig. 363.—INTERIOR ARRANGEMENT OF DARK-ROOM.

capable of being very satisfactorily adapted for the purposes of a dark-room. The first thing to arrange is the water supply. There should be at least three or four taps, and a stoneware or lead-lined sink with a properly trapped waste-pipe. This part of the work should be entrusted to skilled hands; nothing is more undesirable than indifferent plumbing in a dark-room. Very convenient portable sinks of various patterns may be obtained, of which Fig. 362 is a good example; these simply require connection with any available

BENCHES AND SHELVES.

A continuous bench should be run round the remainder of the room, its top level with that of the sink, and of a width which must be settled by circumstances—say, from 18 to 24 in. This may be covered with sheet lead, treated with any water-proof varnish or painted. It may be left plain without much harm being done, except that it will be more troublesome to keep clean. A number of shelves for bottles, chemicals, etc., should be arranged with due regard to space and convenience,

their accessibility to the operator being the chief consideration. The shelves intended for those articles or reagents which will be constantly in use should be placed over the work-bench within easy reach; while the heavier and less frequently used accessories may be put farther away. Shelves should be made underneath the benches in the form of gratings, to hold dishes of various sizes when not in use, as shown by Fig. 363, which is a good example of how the shelves and benches should be

able; these cause the water to issue in a finely divided spray, and are turned on and off by simply swinging the arm from side to side. A rose attachment, which can be fixed to any ordinary tap, is now procurable; this also serves to filter off the grosser impurities of the water (see Fig. 205, p. 125). A common mistake in fitting is to fix the taps too high, thus bringing about considerable splashing. At the same time, it must be borne in mind that the lower the

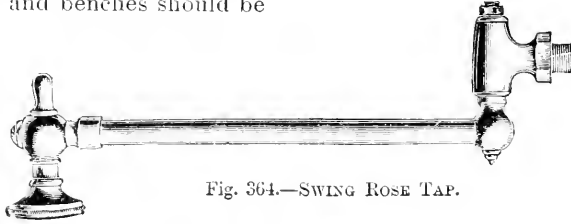

Fig. 364.—SWING ROSE TAP.

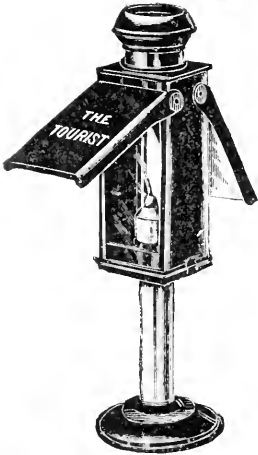

Fig. 365.—DARK-ROOM LAMP FOR CANDLES.

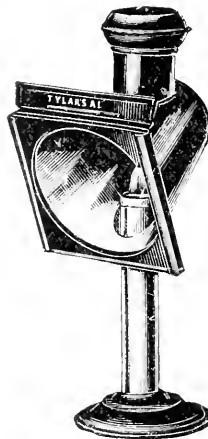

Fig. 367.—COMBINED DARK-ROOM AND LECTURE LAMP.

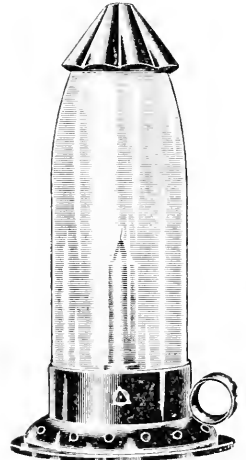

Fig. 366.—HOCK BOTTLE CANDLE LAMP.

arranged. It will be noted that the window has been blocked out with an opaque wooden frame, and that ventilation is effected by means of a light-trapped contrivance above.

TAPS FOR WATER SUPPLY.

Ordinary taps should be avoided, if possible, as the water issues from these with too much force and splash, and is liable to damage the delicate film of negatives and prints. Taps of the swing rose form, as shown by Fig. 364, are most suit-

able; these cause the water to issue in a finely divided spray, and are turned on and off by simply swinging the arm from side to side. A rose attachment, which can be fixed to any ordinary tap, is now procurable; this also serves to filter off the grosser impurities of the water (see Fig. 205, p. 125). A common mistake in fitting is to fix the taps too high, thus bringing about considerable splashing. At the same time, it must be borne in mind that the lower the

THE DARK-ROOM LAMP.

It is better to carry on the operations of development by artificial light, for the reason that daylight is constantly varying in intensity, thereby making it difficult to secure uniform density in a series of negatives. It is a great advantage if the lamp used for lighting is placed outside the dark-room: this can be done by support-

ing it on a shelf or bracket in front of a ruby window. By this means the heat and fumes of the gas or oil are avoided. With an oil lamp there would be some difficulty in regulating the light; but if gas is used,

candles, paraffin, gas, or electricity. Candle lamps are admirably adapted for tourists, and for dark-rooms where only a small amount of work is to be done. Patterns of these are shown by Figs. 365 to 367. The last can also be used, with a white glass, as a reading lamp for lantern lectures. Hard candles, such as those used for carriage lamps, are best, the ordinary variety being too soft. Special candles may be obtained for this purpose.



Fig. 368.—TRIANGULAR OIL LAMP.



Fig. 369.—PYRAMIDAL LAMP FOR OIL.

the supply tap could be fixed inside the dark-room. For a fairly large room there is no objection to the employment of any ordinary form of lamp suitable for the purpose. These can be obtained for use with

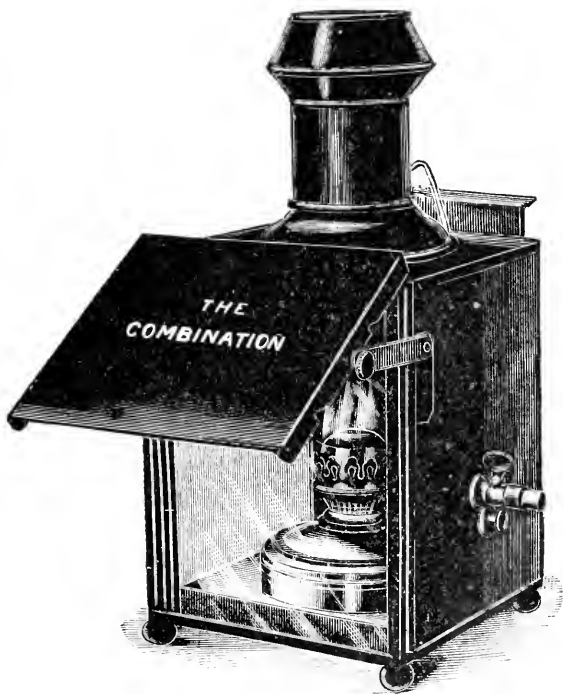

Fig. 370.—LAMP FOR OIL OR GAS.

If an oil lamp is used, it should have an arrangement for adjusting the height of the wick from the outside; otherwise, if it burns down while a plate is being developed, there is no opportunity of turning it up without opening the lamp and so fogging the plate. Two good patterns are shown by Figs. 368 and 369, while Fig. 370 has the merit of being suitable for either oil or gas. Whatever kind may be chosen, the lamp should be provided with both red and yellow glasses, the latter for use in developing bromide paper. For a

very large room, more than one lamp will be required.

GAS LAMPS.

Gas is probably the most satisfactory illuminant for the dark-room. It possesses the advantage over electricity that the amount of light may be exactly regulated; otherwise the latter would, no doubt, be preferable. In laying on gas to the dark-room, great care should be taken that sufficient pressure is assured to maintain a

workers for dark-room illumination. Its advantages are that it can be switched on and off in an instant, it throws off no objectionable products of combustion, and ensures a cool atmosphere. Ruby globes are obtainable to fit any existing electric light fittings, or the ordinary white bulbs may be readily stained to a suitable colour with a non-actinic varnish or stain. It is even feasible to simply tie up the bulb in a couple of folds of ruby fabric. Special electric lamps of various patterns are pro-

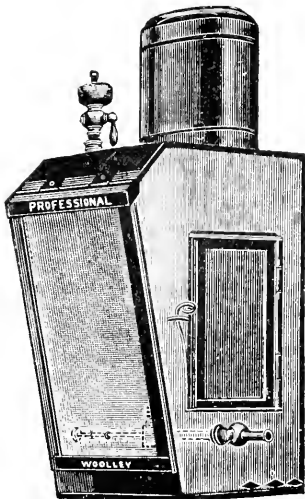

Fig. 371.—DARK-ROOM LAMP FOR GAS.

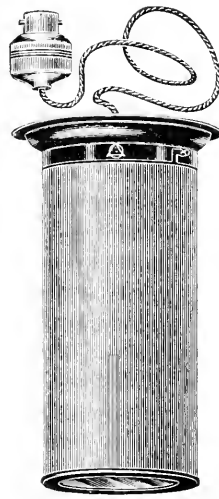

Fig. 372.—ELECTRIC DARK-ROOM LAMP.

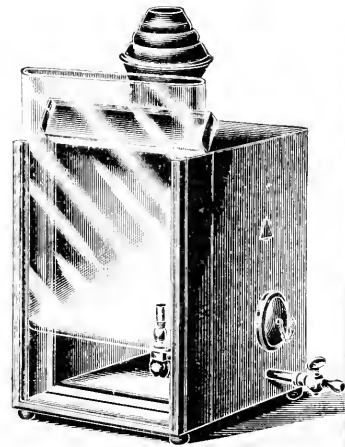

Fig. 373.—BICHROMATE LAMP.

steady and constant light. This point is often overlooked, with the result that nothing but a glimmering light can be obtained. A very suitable form of gas lamp is shown by Fig. 371. This, it will be noticed, is provided with a by-pass burner at the top, so that the operator may obtain a white light whenever it is required without opening the lamp. When gas is the illuminant employed, extra attention must be paid to the ventilating arrangements, an additional ventilator or flue over the lamp being desirable.

ELECTRIC LAMPS.

In spite of the drawback that the exact amount of light cannot be regulated, electricity is a great favourite with many

workers, one of these being illustrated by Fig. 372.

BICHROMATE LAMPS.

Many workers prefer to use, in place of a lamp fitted with ruby or orange glass, a glass cell filled with a solution of potassium bichromate. This is perfectly safe to work with, and allows a larger amount of light to be used, a liquid filter of this description having a proportionately greater effect in cutting off the actinic rays of the illuminant. A lamp provided with a bichromate tank, and intended for use with either gas or electricity, is illustrated by Fig. 373. These tanks may also be obtained separately, for use with existing lamps, supplied with a screw-tap

for filling (see Fig. 374). As they may be filled with any kind of light-filtering medium, an opportunity is thus afforded of matching the actinic quality of the lamp exactly to the requirements of any particular plate. This subject will, however, be dealt with in a later section.

"SAFETY" OF THE DARK-ROOM LIGHT.

It does not follow, because a lamp is fitted with ruby glass, that there is no danger in manipulating rapid plates by it. Some shades of ruby are quite unsuitable for the purpose, allowing too large an amount of actinic light to escape. The lamp should, therefore, be carefully tested

Still, it is always advisable to cover up the plate, if development is long continued, for there is no light absolutely non-actinic. For this reason, the plate, especially if rapid, should be kept out of the direct rays of the lamp as much as possible.

DISHES.

The larger the number of dishes available, the more readily and conveniently can the work be carried out. The dimensions will depend on the size of the plates generally used, and the extent to which toning, enlarging, and similar operations

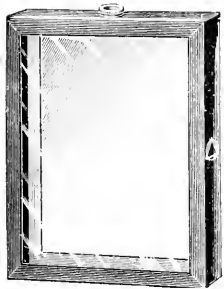

Fig. 374.—CELL FOR BICHROMATE LAMP.

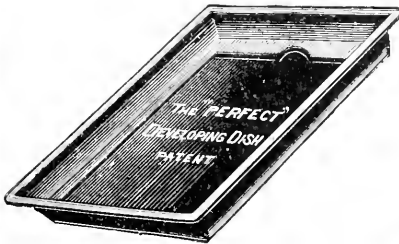

Fig. 375.—RECESSED DEVELOPING DISH.

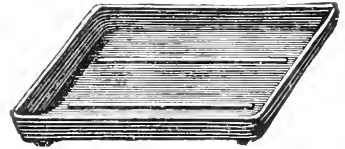

Fig. 376.—RIDGED DISH WITH RAISED FEET.



Fig. 377.—DEEP DEVELOPING DISH.

beforehand. The best way to do this is to place a rapid plate in a dark-slide, draw one half of the shutter, and expose the plate to the light of the lamp, in the place usually occupied by the developing dish. Let it remain for a quarter of an hour, or a little longer. The plate should then be immersed in the developer, in the usual manner; and if there is any discoloration on the exposed portion, the lamp must be condemned as unsafe for plates of that rapidity. In such a case, the fault may generally be remedied by the addition of a thickness of orange or ruby fabric in front of the ruby glass. It must also be remembered that what is a perfectly safe light for one brand of plates may be unsafe for another. The amount of light has nothing to do with the question. A large quantity of light may be used with perfect safety, provided it is of the right quality.

are undertaken. It will be more satisfactory to consider, at present, only those dishes which are used in developing, leaving the other kinds to be dealt with later. Something has already been said (see p. 17) about developing dishes, several patterns being illustrated on p. 16. These, however, by no means exhaust the numerous patterns which may be obtained. Figs. 375, 376, and 377 show three other kinds of dishes, each of which has its own special feature. Fig. 375, for instance, contains a recessed rebate, the size of the plate to be used, so that the surface of the film forms the actual bottom of the dish. This results in the plate being covered with more than the usual quantity of developer, and in less waste taking place. It is, in fact, possible to use a smaller quantity of solution, although this is not

generally to be recommended. A large dish of ebonite is best for fixing purposes, the position for this being under the bench or on the floor, as there is then no chance of the hypo. being splashed about. It is a good plan to mark each dish according to the use to which it is to be put, as, for

TANKS.

A good supply of tanks for washing negatives, etc., should be provided. These may be of metal or stoneware, and are obtainable in various patterns, to suit different requirements. They must be



Fig. 378.—NAIL RACK FOR DRYING NEGATIVES

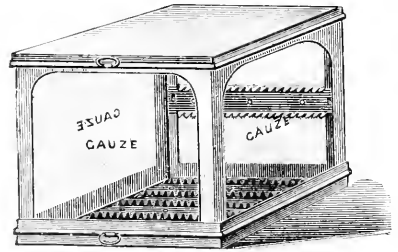

Fig. 381.—GAUZE DRYING BOX.

cleaned out occasionally, as there is always a deposition of grit and dust, which may find its way to the delicate gelatine film. Neglect of this precaution results in an increased number of spots and pinholes on the negatives. Further details concerning tanks will be found in the section on the "Development of Plates and Films" (p. 126).

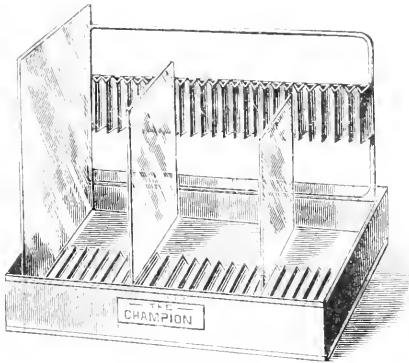

Fig. 379.—FOLDING METAL RACK, OPEN.

RACKS.

These also are dealt with in the section on Development (p. 126), as well as in the first section (p. 20). A few hints will be

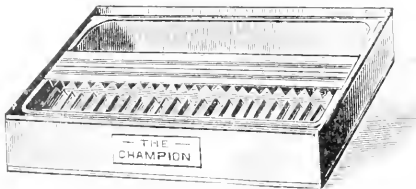

Fig. 380.—FOLDING METAL RACK, CLOSED.



Fig. 382.—GLASS MEASURE WITH OPAL SCALE.

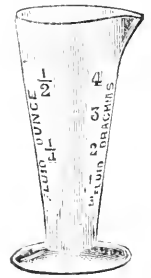

Fig. 383.—GLASS MEASURE WITH OPAL SCALE.

example, "Pyro. Developer," "Ferrous Oxalate," and so on. This should be done in waterproof varnish or paint, of a colour which will be distinctly visible against its surroundings in the light of the dark-room.

given here on the making of emergency racks for drying negatives when all the ordinary racks are occupied. One method is to drive a series of long nails at intervals in the wall, where there is any open

space. The negatives can then be placed on these, as shown in Fig. 378, the lower corner touching the wall, with the film downward. The nails should be arranged at different distances to suit various sizes of plates. Another way is to make a series of saw-cuts about $\frac{1}{2}$ in. deep, and 1 in. distant from each other in the upper surface of any available shelf. There is nothing to interfere with the ordinary use of the shelf, while in an emergency

This permits of negatives being safely placed outside to dry in a current of air, without any risk of attracting dust and grit. It is also a convenient receptacle for negatives which are in the drying stage when it is desired to clean or sweep the dark-room. A drying chamber is almost indispensable for the more delicate operations, such as those involved in photo-mechanical work. A good pattern is shown by Fig. 381.

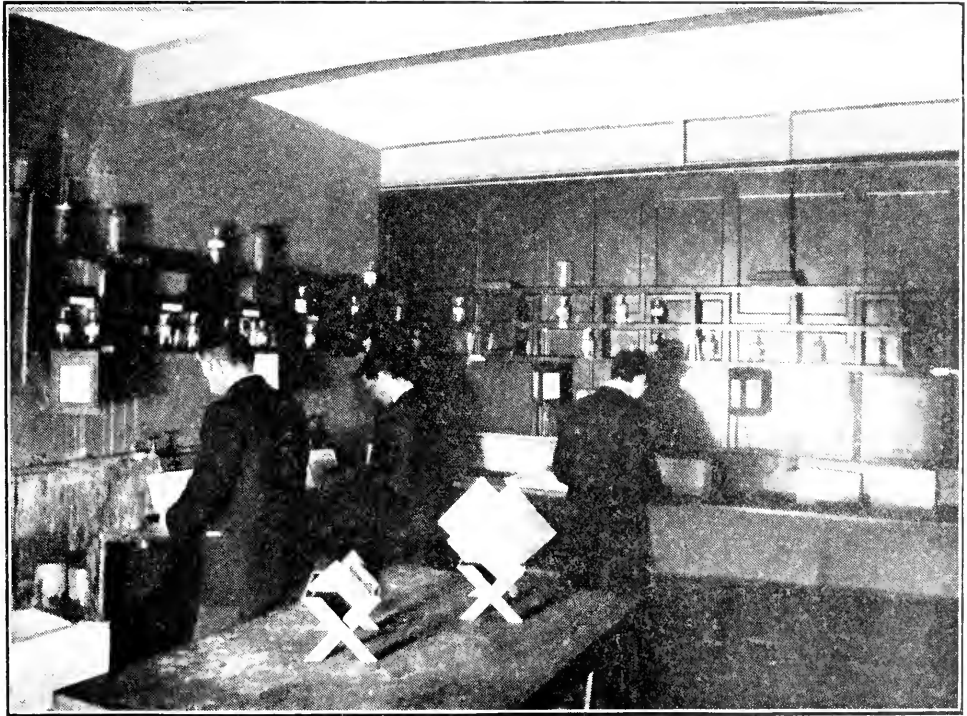

Fig. 384.—ARRANGEMENT OF LAMPS IN DARK-ROOM.

the articles on it may be removed and the negatives stood up to dry, by resting them in the saw-cuts, which, of course, should be made wide enough to permit the easy insertion and withdrawal of the negatives. A convenient pattern of folding rack is shown by Figs. 379 and 380.

DRYING BOXES.

A useful article to have in a dark-room is a gauze-lined drying box or chamber.

MEASURES.

The number of measures required by the photographer depends, of course, on the amount of work undertaken, and the extent to which it is varied or diversified. It is advisable to have as many as possible, if only as a precaution against accidental breakage. Various forms of glass and celluloid measures have already been illustrated; others are shown by Figs. 382 and 383. The objection against glass

measures is that they are so frequently getting broken; but this, as often as not, is due to imperfect illumination of the dark-room. There should be sufficient light to read a newspaper at a short distance from the lamp, and this should be so diffused as to render the shelves and benches easily distinguishable. When this requirement is satisfied, breakages can only occur through carelessness.

LAMP SHADES.

The proper height for the lamp is slightly above the bench, so as to be nearly on a level with the operator's head, as shown by Fig. 384. In all cases a shade that will protect the eyes should be provided, as long exposure to the ruby light of a dark-room injuriously affects the

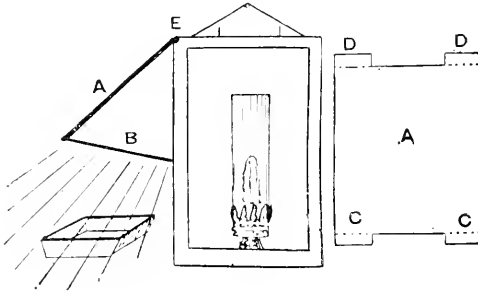

Fig. 385.—SHADE FOR DARK-ROOM LAMP.
Fig. 386.—PATTERN FOR CUTTING SHADE.

operator's eyes. Fig. 355 shows a suitable and easily made arrangement. Construct a flap for the lamp by fastening a piece of tin A (see also Fig. 386) over a V-shaped wire B by bending on the dotted lines C (Fig. 386). The pieces D clip a wire soldered at E, and the flap is fixed so that it may be let up or down as required. A great deal of red light may be used if the plate is carefully shaded from the direct rays of the lamp. The operator should not work too near the light, which should be kept as low as possible until the half-tones appear. The plate may then be covered, and need not be examined again until development is finished. By using time development very little light need reach it.

SCALES AND WEIGHTS.

These may be of any pattern, accuracy and convenience being the main considerations. It is an advantage if a movable glass pan is provided for weighing the chemicals. In addition to the ordinary scales, of which several designs have already been illustrated, one of the kind shown by Fig. 387 is decidedly handy for weighing small quantities of chemicals quickly. No weights are required, the necessary information being indicated by a graduated scale. Confusion sometimes arises from the lack of uniformity in the British system of weights and measures, scales to weigh small quantities being generally provided

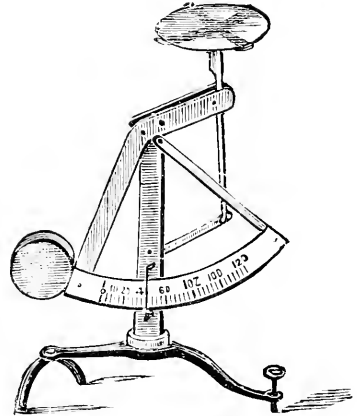

Fig. 387.—DARK-ROOM BALANCE.

with weights for the apothecaries' table, and those for larger amounts with avoirdupois weights. This should always be borne in mind when ordering or weighing chemicals.

MAKING-UP TEN-PER-CENT. SOLUTIONS.

The photographer's usual method of making a 10-per-cent. solution is to dissolve 1 oz. of the salt in 9 oz. of water, but the result is only approximately correct. For most purposes, the inaccuracy is of no practical account, but a few chemicals used in photography (bromide of potassium is one of them) must be accurately measured. Ten fluid ounces contain 4,800 fluid grains, and should therefore contain 480 grs. of

the salt. Chemicals are always sold by avoirdupois weight, 1 oz. of which contains $437\frac{1}{2}$ grs., the apothecaries' ounce consisting of 480 grs. Drops are popularly supposed to be the same as minims, but this is incorrect, as drops of different solutions vary in size. In order to make up a percentage solution, find the capacity of the bottle that is to hold the solution by filling the bottle with water and measuring the contents in a graduated measure. Suppose the bottle holds 9 oz. 1 dr. = 4,380 minims; in order to make a 10-per-cent.

solutions. It is impossible to give an exact estimate of what will be required, as so much depends on circumstances and the scale on which the work is to be carried out. Lay in a small quantity of bottles of different sizes with a representative collection of chemicals to start with, and

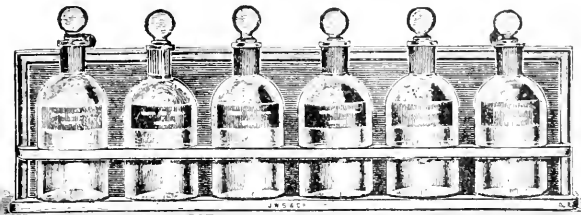

Fig. 388.—BOTTLE RACK.

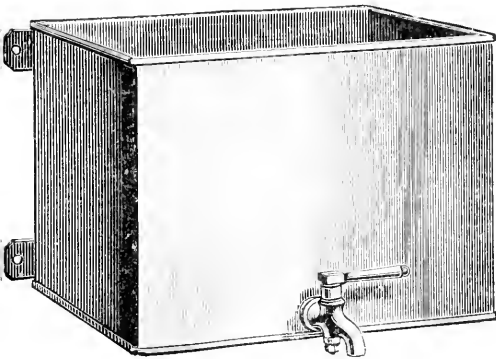

Fig. 390.—PORTABLE CISTERN WITH TAP.

solution, dissolve $437\frac{1}{2}$ grs. of the solid (or 1 oz. avoirdupois) in 4,375 minims of water, and then every ten drops or minims of the solution will contain 1 gr. of the solid.

STORAGE REQUISITES.

An adequate supply of wide-mouth stoppered bottles should be obtained, of different sizes, for the storage of chemicals and reagents; and a number of large stoppered bottles with narrow mouths for stock

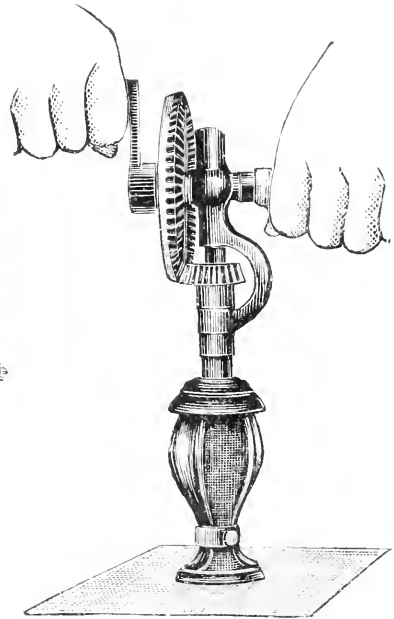

Fig. 389.—WHIRLER WITH PNEUMATIC HOLDER.

add to these as required. One or two small cupboards should be fitted up for those chemicals and solutions which have to be kept from the light, as it often happens that the dark-room is used for other purposes—toning, for instance—when daylight may have to be admitted. A suitable cupboard should also be provided for the storage of dry-plates and bromide papers. If plate-making is attempted, a light-tight drying cupboard will be necessary. Solutions required for use are better kept in smaller bottles. Very convenient racks are supplied for these, in which they are readily accessible and free from risk of breakage (see Fig. 388). Grooved, light-tight plate boxes for holding plates which have been unwrapped, both exposed and unexposed, are necessary where a large quantity of work is done.

SPECIAL APPLIANCES FOR SPECIAL WORK.

Special appliances for particular branches of work taken up by the photographer must have their allotted place in the dark-room. For the coating of plates,

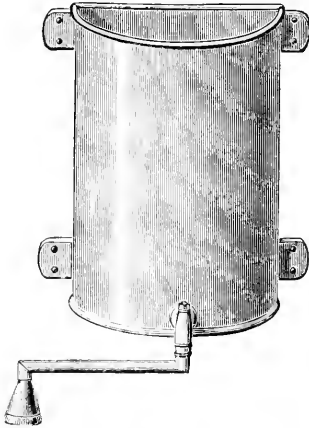

Fig. 391.—PORTABLE CISTERN WITH SWING ROSE.

a levelling and cooling slab, emulsion pot and saucepan, etc., will be needed. If photo-mechanical work is undertaken, many additional accessories will be wanted, such, for instance, as the whirler, a device to hasten the setting or drying of the plates by rapidly revolving them. A typical pattern of whirler, which is useful for many other purposes, is shown by Fig. 389. The plate is held tightly by the pneumatic holder at the bottom, and caused to revolve quickly by turning the handle

at the left. These special appliances, however, will be dealt with in the sections devoted to those processes in which they are used.

PORTABLE CISTERNS.

In cases where it is not convenient to have the water laid on to the dark-room, or where the supply is not constant, the best plan is to obtain a portable water tank or cistern. These are procurable in various sizes, fitted with a tap, and having plates at the back for nailing to the wall. They will, of course, have to be filled by hand at regular intervals. Figs. 390 and 391 show two suitable patterns, the latter being provided with a swing rose. A beer jar or barrel will, however, serve the purpose very well, while in an emergency a couple of pails may be utilised.

IMPORTANCE OF ORDER AND CLEANLINESS.

In closing this section, reference may again be made to the importance of order and method in the dark-room. The photographer who is content to allow the developing chamber, where some of the most delicate operations of photography are carried out, to become in appearance little better than a lumber room, is courting failure. The utmost neatness and precision should be observed, in every particular. The craftsman of the camera who takes a pride in the systematic arrangement of his dark-room, and in the spotlessness of everything contained in it, will reap his reward in the excellent results which are sure to follow.



PROFILE TURNED AWAY FROM LIGHT.



SIDE FACE TURNED TOWARDS LIGHT.

EXAMPLES OF STUDIO LIGHTING.

MOUNTING AND FRAMING PHOTOGRAPHS.

INTRODUCTION.

It need hardly be pointed out that tasteful mounting and framing have a great influence on the appearance of the finished photograph. It is possible to ruin the appearance of a print by an unsuitable choice of mount or indifferent framing; while a poor, second-rate picture may be made to look much better than it really is by discriminate and artistic treatment in this respect. Much, of course, depends on the character of the photograph and the purpose for which it is intended. A pictorial landscape, for instance, would be treated quite differently from a portrait enlargement. Due consideration will be given to these points in this section, which contains directions to meet every requirement of the photographer.

COMMERCIAL MOUNTS.

By the term commercial is meant those mounts which are obtainable ready for use from the photographic dealers, as distinguished from the various home-made combinations of tinted papers and boards. There are two distinct kinds of commercial mounts—namely, the paste-down and the slip-in. In the first, the print is attached by means of starch or other adhesive to the face of the mount; in the second, it is placed behind a cut-out opening, thus saving the trouble of pasting. A good print will look well either way; the paste-down method being more suitable for ordinary purposes and professional work, and the slip-in mounts for occasional prints or for framing. Both kinds are procurable in great variety, to suit all tastes, from extreme plainness and simplicity to the height of elaboration.

PLATE-SUNK MOUNTS.

These are paste-down mounts on which a plate-mark has been stamped, similar to those sometimes seen round a steel engraving. The plate-mark is a great improvement to some prints, especially those of a delicate nature. These plate-marks may be produced by placing a thick round-cornered sheet of cardboard of the necessary size on the mount to be treated, and subjecting them to pressure. The effect can also be very well imitated by cutting a sheet of zinc to the required shape, making it moderately hot, and pressing it down on the mount with an ordinary flat-iron. Care should be taken that the zinc plate is not so hot as to scorch the mount.

INDIA-TINT MOUNTS.

The India-tint consists of a thin sheet of creamy or yellowish paper, pasted in the centre of the mount so as to form a narrow margin round the print when the latter is mounted over it. It is often seen in association with the plate-mark, but it is also very effective by itself. The India-tint is not restricted to a particular colour, but may be obtained in many different tints and shades. It is easy to make, a sheet of paper of the desired colour and size being simply pasted down over the mount, in the same manner as an ordinary print. The correct method of doing this will be described later. The India-tint mount is especially suitable for platinotypes and bromides, when a tint of a greyish tinge is employed, the ordinary yellow or buff margin being hardly so adapted for this purpose. In some cases the India-tint is imitated by a printed square, of a suitable colour, in the centre of the mount.

SLIP-IN MOUNTS.

These consist of a mount with a cut-out opening, covered at the back in such a manner that the print may be inserted through a slit at one of the sides. They afford a very convenient method of quickly finishing a picture, when it is desired to avoid the trouble of mounting, and can be made to look extremely well. When used for P.O.P. prints, it is better for the latter to be dried with a glazed surface, or they will not look flat enough. For small prints,

Cutters set to the required angle are now obtainable, by means of which the photographer may make his own cut-out mounts. They may also be made with an ordinary sharp penknife and a steel straight-edge. The size of the opening is first drawn neatly and squarely on the mount, and is then cut out with a penknife in the ordinary way, the knife being held at an angle to form the required bevel. The mount should be placed on a sheet of glass or metal for cutting, and care should be taken to keep the knife from going over the corners.

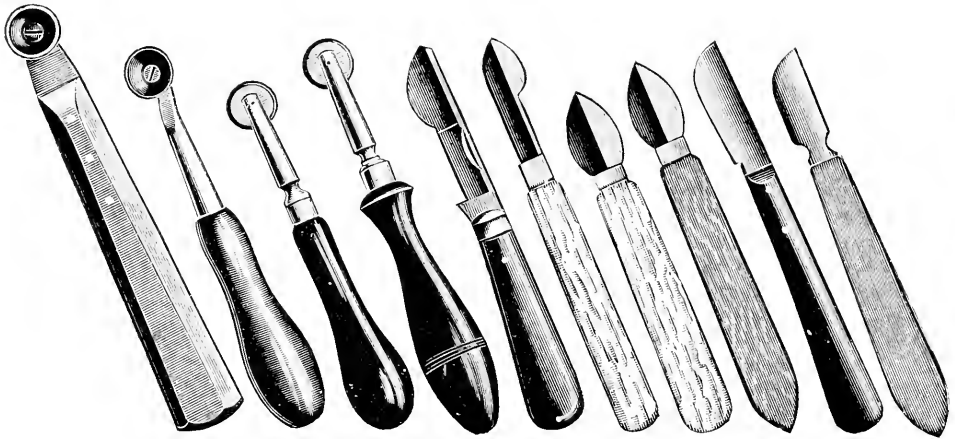

Fig. 392.—TRIMMING KNIVES OF VARIOUS KINDS.

however, this is scarcely necessary. Slip-in mounts are readily made to meet any special requirement. All that is necessary is to cut an opening of the desired size in a suitable piece of tinted cardboard, and at the back of this to glue a sheet of plain cardboard round the margin of three sides only, leaving a slit at the remaining side for the insertion of the print. Slip-in mounts of a plain and quiet description are well suited for framing.

CUT-OUT MOUNTS.

The cut-out mounts are more adapted for large prints and those which are to be framed. As the name implies, they consist of an opening cut in a sheet of plain tinted paper or cardboard. As a rule, the edges of the opening are cut at an angle, so forming a bevel, though this is not always done.

VENEER MOUNTS.

These are a variety of cut-out mount, the upper surface being a thin sheet of wood veneer. When nicely figured, they are very artistic, and look well in frames of a similar wood. Much, however, depends on the nature of the print. The eye must not be attracted by the mount to the neglect of the picture. This is, indeed, a point which must never be overlooked in mounting. The print is to be the centre of attraction, and the mount must be selected on account of its suitability for the picture, not for its own intrinsic beauty.

MOUNTANTS.

One of the best mountants for photographic purposes is ordinary laundry starch, the "Glenfield" brand being the most suitable. The starch should be mixed

with a small quantity of cold water, and rubbed with a spoon till it forms a perfectly smooth cream. Boiling water should then be poured in, stirring all the time, until a transparent jelly-like paste results. When cold, it should be thick and stiff. On removing the outer skin from the top with a knife or spoon, the starch is ready for use. It should be made fresh at least every other day, as it will not keep well. A good mountant may be prepared from arrowroot in a similar manner.

MOUNTING WITH GELATINE.

A thin glue made of gelatine is used by many workers for mounting prints, on account of its greater tenacity. It is made by soaking the gelatine in water until soft, and then raising the temperature until it is dissolved. It is better to use only a small quantity of water at first, and to dilute; if necessary by adding warm water. This mountant will, of course, require to be warmed up each time it is used. A good formula for mounting prints with a glazed surface, to be applied to the edges only, is as follows: Gelatine, 2 oz.; water, 5 oz.; glycerine, $\frac{1}{2}$ oz.; methylated spirit, $2\frac{1}{2}$ oz. The gelatine is first dissolved in the usual way, by the aid of heat, then the glycerine is added, and finally the methylated spirit, stirring well all the time. The same mixture, made a little thinner by the addition of water, may be used for mounting prints by pasting them all over. Some workers use a mountant made by adding gelatine to arrowroot or starch paste, and well mixing. This mixture keeps good for some time, especially if a few drops of carbolic acid or quinine solution are added and the jar tightly covered when not in use.

INDIA-RUBBER MOUNTANT.

The india-rubber solution used by cyclists for repairs is handy in the case of glazed prints, where a mountant containing water is undesirable. The solution is spread over the back of the print and on the face of the mount. The two are set aside for about five minutes, till the rubber is partially dry, when the print is lowered into place on the mount and rubbed down gently. As the print adheres immediately

on contact, and cannot be moved, it must be correctly placed in position at the first attempt. Solution which has gone over the border is easily removed by gently rubbing with the fingers. This is a very neat and clean method of mounting, but the rubber solution is not very durable.

GUTTA-PERCHA MOUNTANT.

Gutta-percha may also be used for mounting. The kind obtained in very thin sheets at the leather seller's is required. A piece is cut the same size as the print, and placed between that and the mount. A sheet of blotting paper is laid on top, and a hot iron passed over slowly, and with a firm but not too heavy pressure. This causes the gutta-percha to melt, and effects a perfect adhesion between the print and the mount. The method cannot be recommended, however, as the gutta-percha is liable to perish.

TRIMMING PRINTS.

Except when a photograph is to be inserted in a slip-in mount or framed close up, trimming is necessary before the picture is mounted. There are many methods of doing this, but the plan most generally followed is to use a glass cutting-shape of the desired size, and, placing the print underneath this, to go round the edges with a sharp penknife or one of the special trimming knives sold for the purpose (see Fig. 392). The print is placed on a sheet of thick plate glass, zinc, or hard wood, and the glass shape kept firmly in position by the fingers of the left hand, while the knife is held steadily against the edge of the shape during the operation, as in Fig. 393. The prints should be dry, so the trimming must be done before toning, or the prints allowed to dry between the toning and mounting. The knife should be of good steel, and must be sharpened occasionally on a fine oilstone, but without using oil. Some workers manage to trim prints very well with a pair of scissors, holding the cutting shape and the photograph together in one hand, and going round each side in turn with the scissors; but this practice is not recommended.

TRIMMING CIRCULAR AND OVAL PRINTS.

For trimming circular and oval prints, ground glass cutting-shapes are obtainable, which are used in the ordinary manner. Sheets of zinc having an opening of the shape required are also very suitable; a set of these, supplied for use with a wheel trimmer with them, is shown by Fig. 394. In trimming prints by this method, it is necessary to keep the cutter nearly upright, and pressed closely against the inside edge of

lows: Cut a print or a piece of ordinary note-paper by means of the glass, and, folding it over without bending, bring the top and bottom edges together (see Fig. 395). These should agree exactly in width. Now fold the paper over the other way, this time bringing the two side edges together; if these also agree, the glass may be regarded as correctly ground. If, however, the folded edges of the print do not agree, the glass is manifestly untrue, and should be rejected.

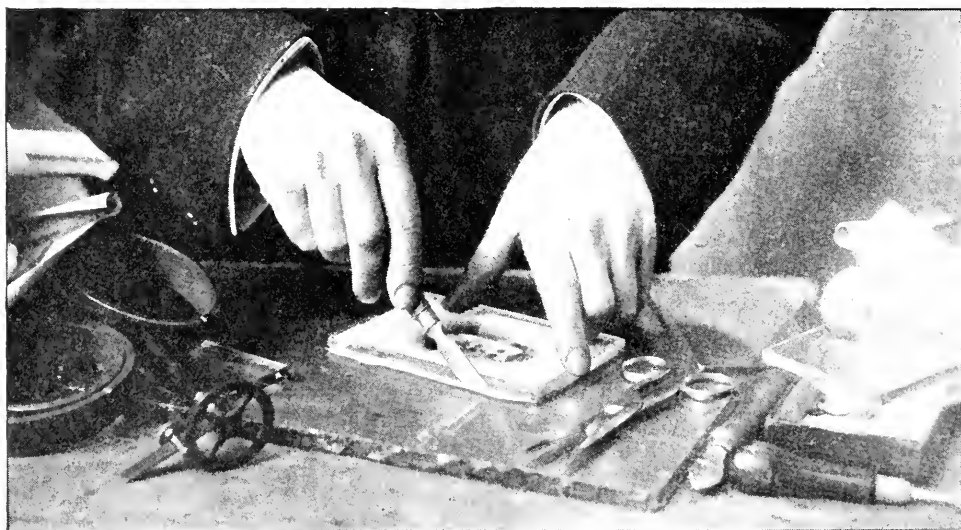

Fig. 393.—PRINT TRIMMING.

the pattern. There are various patented devices for cutting circles and ovals of any size, most of which depend in principle on the revolution of a fixed cutter, somewhat after the style of a compass, the radius being adjustable. In all cases, the knife or cutter should be kept extremely sharp, as it is easier to tear these prints while cutting than those which have straight edges.

TESTING THE CUTTING-GLASS.

In purchasing the glass shapes for cutting rectangular prints, see that they have absolutely straight edges and truly square corners. This is by no means always the case, and it is better to test them before using. This may readily be done as fol-

HOME-MADE TRIMMING-GLASSES.

Some workers prefer to make their own trimming-glasses. Old negative glasses from which the film has been removed may be adapted for the purpose. These should have at least two good straight edges, at right angles to each other, and should be free from cracks or chipped corners. The two edges chosen may be ground perfectly flat by rubbing for a short time on a level window-sill or paving-stone on which a little fine emery-powder or silver sand has been sprinkled, mixed with water. Three pieces of gummed paper are then attached to the back of the glass, as shown by Fig. 396, to serve as gauges by which various sizes of prints may be cut. In order that

the cutting-glass may be exact, it is necessary to measure all the widths on the pieces A and B from the right edge of the glass, and to mark them with extreme care. On the piece C a scale of lengths is inserted, measuring from the bottom. To use the glass, it is placed in position over the print, the right-hand side and bottom of which are then trimmed. The print is now reversed, and the two trimmed edges brought carefully against the correct distance-marks for both width and length by shifting the glass until this is effected. The two remaining sides are then trimmed in the same way.

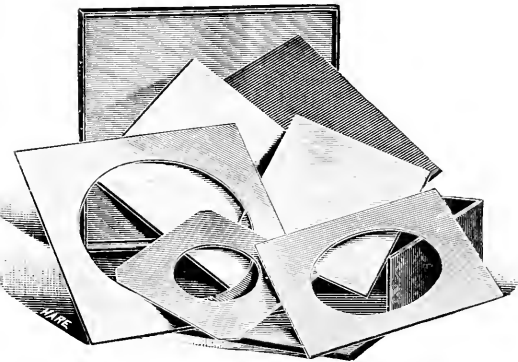

Fig. 394.—ZINC SHAPES FOR TRIMMING CIRCLES AND OVALS.

MAKING ZINC CUTTING-SHAPES.

Special shapes, such as ellipses, ovals, circles, etc., may be drawn on sheet zinc. A ruler and compass are used as for ordinary drawing, and the outline is carefully gone over with a sharp needle-point or tracing tool set in a wooden handle. The surplus zinc is then cut away with a large pair of scissors or shears, and the edges trued up and finished with a small file. If a circular opening is required, this may be cut with a fine fret-saw, smoothing the edge with the file. Sheet iron and brass are also adaptable, but are more difficult to cut. Zinc is often recommended also as a foundation for cutting prints on, as it does not blunt the edge of the knife so much as glass. A good plan is to mount a sheet of zinc on a larger block of hard wood, by means of a recessed screw in the centre, in such a manner that the zinc may revolve

freely. This may then be turned round with the print and cutting shape in position, thus bringing the different parts of the work to a more convenient position for cutting without having to shift the glass or the print.

PRINT-TRIMMING MACHINES.

Various machines on the guillotine principle are now made for trimming prints,

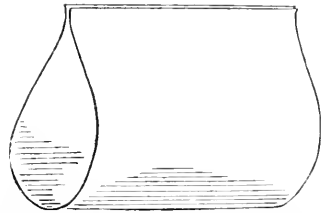

Fig. 395.—TESTING SQUARENESS OF PRINT.

Fig. 397 being a typical example. In this, it will be seen, the print is kept steady by

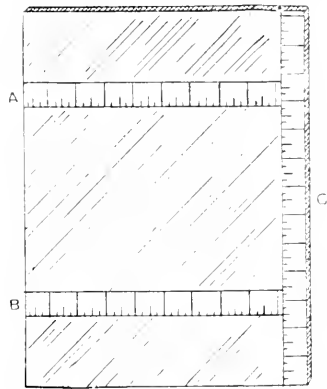

Fig. 396.—HOME-MADE TRIMMING GLASS.

the pressure of the left hand on a movable lever, while the cutting blade is operated by the right hand. The ruled squares on the bed of the apparatus are for gauging the size of the print. These machines are extremely useful for other purposes, such as cutting cardboard, the making of special mounts, etc. With proper care, the blade will not require sharpening very often. This method of trimming ensures a beautiful straight edge and mathematical accuracy of the corners.

RULES FOR TRIMMING PRINTS.

Unless the prints are specifically intended for a certain size of mount, pay no attention to dimensions, but trim to secure

smaller by the process. In seascapes, see that the horizon line is level, and in architectural subjects that vertical lines are perfectly square, taking care to ascertain, however, that such lines are really vertical in the original, as in some old buildings they are not. When the lines of a picture are out of the straight, through neglecting to use the swing-back or other causes, tilt the print a little, when cutting, so as to compensate for this. When some lines are straight and others are not, trim the print to keep the most important line or lines straight. Hold the knife with a slight inward slant, cutting the edges of the print as shown in Fig. 398; this avoids the appearance of a white line round the print.

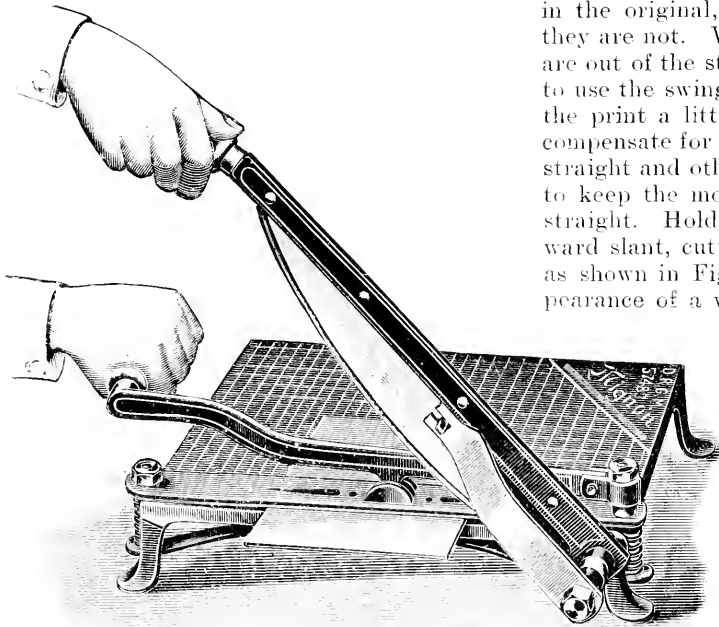

Fig. 397.—PRINT TRIMMING MACHINE



Fig. 398.—PRINT WITH INWARD BEVEL.



Fig. 399.—PRINT WITH OUTWARD BEVEL.

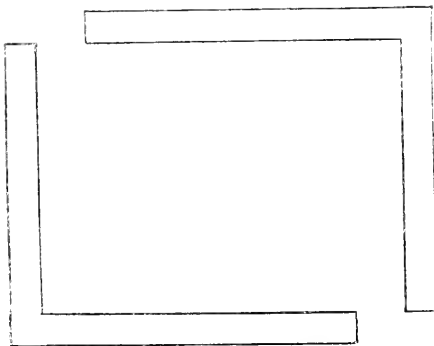

Fig. 400.—CARDBOARD ANGLES.

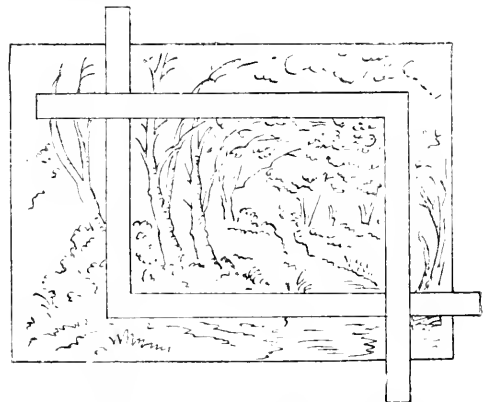

Fig. 401.—METHOD OF PLACING ANGLES ON PRINT.

the best effect, regardless of what has to be cut away. A picture is often greatly improved by the removal of unnecessary portions, even though rendered very much

as would be the case if the knife sloped ever so little the other way (see Fig. 399). Even if the knife is held vertically the effect is not so good, for the upper surface

of the print tends to contract in drying, thus often causing the undesirable white edge.

CARDBOARD ANGLES.

A pair of cardboard angles (Fig. 400) are a great help in judging how a print should be trimmed to secure the best effect. They are laid on the print as shown in Fig. 401, and moved about so as to display varying proportions of picture, until the best view



Fig. 402.—TRACING POINT FOR MARKING

has been obtained. The corners are then marked with a pencil, or a needle set in a handle, and the print trimmed in the usual manner. An engraver's tracing point (Fig. 402) is a handy tool for marking prints and similar purposes. The cardboard should

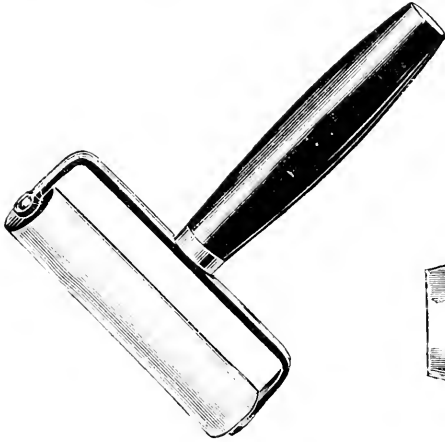

Fig. 403.—ROLLER SQUEEGEE.

be cut with accurate angles, and the edges marked off in inches and fractions of an inch.

PASTING.

The most usual method of mounting is with starch made as already described (p. 274). The trimmed prints are placed in a dish of clean water, and allowed to soak for about half a minute. They are then laid together in a pile, one over the other, on a sheet of glass, and the surplus water is removed by gently passing a roller squeegee over the back. The squeegee is a movable roller of indiarubber, provided

with a suitable handle (see Figs. 403 and 404). Another form consists of a strip of flexible rubber fixed in position in a flat holder of wood. All being ready, the starch is applied to the top print with a hog-hair brush, one of the form shown by Fig. 405 being most satisfactory. The

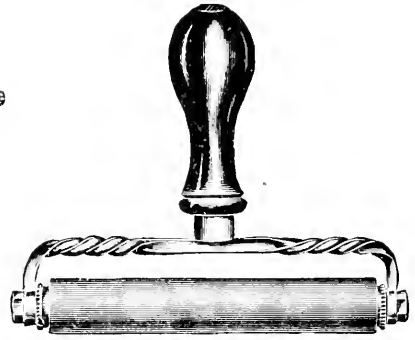

Fig. 404.—ROLLER SQUEEGEE.

starch should be well rubbed in with the brush, and distributed evenly all over the print, care being taken that the edges are properly coated: the method of application is illustrated by Fig. 406. Any lumps

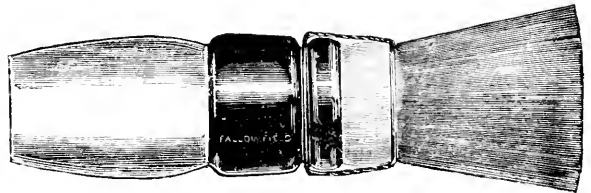

Fig. 405.—MOUNTING BRUSH.

or particles of grit should be removed with the small blade of a penknife.

RUBBING DOWN.

The penknife is now inserted gently under one corner of the print, and the latter raised with the left-hand finger and thumb. The diagonally opposite corner is then taken between the right-hand finger and thumb, and lowered carefully into position on the mount (see Fig. 406). The extreme edges of the print should not be touched, or the paste will be removed. The print may be shifted with the fingers, if necessary, until it is in the correct position. A

sheet of white blotting-paper, or, better still, stout fluffless mounting board, is placed over the print, and the roller squeegee passed lightly across it several times. The mounted print is then laid aside to dry spontaneously. Another method is to rub down with the palm of the hand, the clenched fist, or the tips of the fingers, going from the bottom to the top

being safely rubbed down with blotting-paper. In this case, it is better to press the print down gently into contact by means of successive dabs with a perfectly clean and soft sponge, which must be free from all grit. Carbon prints may also be treated in this way; but they require very careful handling, as the film is extremely delicate and easily damaged. All prints,



Fig. 406.—PASTING AND MOUNTING PRINTS.

of the blotting-paper in horizontal strokes, with a fairly strong but not too heavy pressure. Some workers stroke the print down with a straightedge or ruler. Any paste which comes over the print or gets on the mount may be removed with a clean sponge.

MOUNTING WITH THE SPONGE.

Bromide and P.O.P. prints have sometimes too sticky a surface to permit of their

however mounted, are improved by wiping lightly over the face with a sponge before setting aside to dry.

DRY MOUNTING.

The print is often mounted without previous wetting, as this tends to prevent cockling or curling of the support, and is less liable to damage the surface of the print. One way of doing this is to lay the print face down on a sheet of clean paper,

holding it firmly in position with the fingers, and applying the paste rapidly and evenly. Then, before the print has a chance to expand, it is laid on the mount, covered with blotting-paper, and rubbed down as before described, using rather more pressure. Another method, very suitable for mounting glazed or enamelled prints, is to brush over the backs of the prints with a strong solution of gelatine, or glue of a soft and soluble variety. In the case of glazed prints, this may be done while they are drying on the ferrotype plates or glasses. When dry, the mount is slightly damped with water which is just warm, the print laid on it, and the two passed together through a burnisher or rolling press, with a good deal of pressure. This system effectually prevents cockling.

DRY MOUNTING WITH HEAT.

Shellac dissolved in alcohol or methylated spirit, to the consistency of thick cream, is excellent for dry mounting. The solution is brushed evenly over the backs of the prints and allowed to dry. The print is then adjusted on the mount, a sheet of clean, smooth paper placed over it, and a hot iron applied with gentle pressure. This has the effect of melting the shellac and ensuring the perfect adhesion of the print to the mount, without any trace of cockling. The iron should not be too hot; and it is only necessary to pass it two or three times over the print. The shellac solution may also be used for mounting in the ordinary way, if the operation is done quickly, so that the spirit does not have time to dry before rubbing down. This method is well adapted for very thin mounts.

THE DEREPA'S DRY MOUNTING PROCESS.

This is a patented method of dry mounting by the agency of heat. A thin adhesive film is placed between the print and the mount, the three being inserted in a machine which applies both heat and pressure. In a few seconds perfect adhesion is secured by the melting of special ingredients contained in the film, the mount remaining flat and the print keeping its original dimensions. By this method large

numbers of prints may be mounted in succession, neat and clean, on even the thinnest mounts, without wrinkling or cockling. Any material or fabric may be used. A further advantage is that complete isolation is ensured between the photograph and the mount, so that even if the latter contains injurious matter the permanency of the print will not be affected. The process is especially applicable to the insertion of photographs as book illustrations, generally rather a difficult thing to accomplish if the paper is thin. Several patterns of machines, of which Fig. 407 is a typical example, are made by the Adhesive

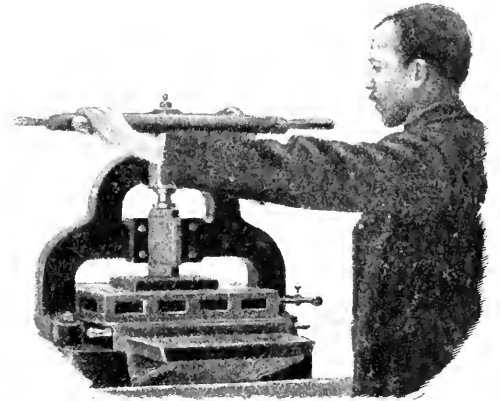

Fig 407.—MACHINE FOR DRY MOUNTING.

Dry Mounting Company. The one illustrated will roll and mount prints with any surface, and will give, if required, a plate-mark or relief border.

STRETCHING OF PRINTS IN MOUNTING.

When prints are mounted wet they tend more or less to stretch, generally in the direction of the width of the original sheet. It should be noted which way the paper stretches, so that the print may be trimmed to allow for this. The slight distortion introduced is seldom of consequence, except in scientific and similar work, where the greatest accuracy is necessary; but in such cases, it is advisable to adopt a dry mounting process. This stretching of the print, as pointed out in another section, may sometimes be turned

to good account in portraiture, as, for instance, in the case of a subject with a long face, which may be improved by cutting the paper so that it will stretch in the width: while features which are too broad may be improved by cutting the paper in the other direction.

INJURIOUS INGREDIENTS IN MOUNTS.

Care should be taken that the mount contains no chemical or injurious matter likely to affect the permanency of the print. White cardboard is frequently treated after bleaching with sodium thiosulphate, the ultimate effect of which on a photographic print can easily be imagined. The presence of hypo. may be detected as follows: Cut one of the mounts in pieces, and soak in hot water for some time: then pour portions of the water in which they have soaked into test tubes. To one of these, add a few drops of silver nitrate solution; a white precipitate, shortly turning brown, shows that hypo. is present. To the second, add a small quantity of very dilute potassium permanganate solution: hypo. will discharge the colour. To the third, add some hydrochloric acid and a few small pieces of zinc: or the mount may be brushed over with iodide of starch, when, if hypo. is present, the colour will disappear. Hypo., of course, is not the only injurious matter that may be present in mounts, but it is the one most often met with in this connection. A good test is to attach a valueless print to a suspected mount, and when dry cut it in half. One half is then placed in a dish of clean water, covered over, and allowed to soak for several days. The two halves are then compared, when any impurities in the mount will probably have caused stains or fading.

MAXIMS FOR MOUNTING.

A delicate picture requires a light mount, and a heavy picture, in which the lights want bringing out, a dark mount. The mount should not, as a rule, be so dark as the deepest shadows of the photograph, nor so light as the brightest lights. The colour of the mount should not be exactly the same as that of the print, nor of so striking

a contrast as to attract special notice. Strong and crude tints should be avoided; subdued shades of green, brown, and grey are most suitable. A rough-surfaced print should not be placed on a very smooth mount, nor should the opposite be done. The mount should not be more prominent than the print, and for this reason ornamentation is as a rule inadvisable. The picture should be placed nearer the top of the mount than the bottom, unless there is an equal margin all round; while even then it appears to be more nearly in the centre if placed a little higher than truth.

BORDERS AND LETTERING.

A plain ruled border round a print is occasionally an improvement, though not in every case. This may be done with a quill pen filled with Chinese white or Indian ink; an adjustable ruling pen is even better. Ornamental titles and lettering may be of the same colours, using the quill pen. Simplicity and neatness should be studied, and over-elaboration carefully avoided. The lettering may be drawn very lightly in pencil before inking. Various shades of grey may be obtained by mixing the Chinese white and Indian ink in varying proportions. The colour should not be used too thin, or it will tend to run. Vermilion is occasionally effective, on a very dark mount, but must be used with caution. Gold and silver writing fluids are obtainable, but cannot be recommended.

OPTICAL CONTACT MOUNTING.

This consists of permanently attaching the print to a sheet of glass by means of gelatine. Prints mounted in this way are commonly known as "opalines." The process is applicable to any kind of print, although more generally used with those on P.O.P. Suitable bevelled glasses are obtainable from any photographic dealer. A better effect is produced by masking the print, so that a white margin is left all round; but the same end may be attained by having the print smaller than the glass, and backing with white paper. One ounce of gelatine is soaked in an earthenware jar of cold water until soft; the water having been strained off, 5 oz. of boiling water are

then added, and the jar stood in a saucepan of warm water till the mixture is thoroughly dissolved. It is then filtered through muslin into a glass or porcelain dish standing in a larger dish of hot water, which should be kept at about 100° F. The glasses having been well cleaned, the dry prints are placed in the warm gelatine till soaked, then laid quickly on the back of the glass, and at once squeegeed down with moderate pressure. The surplus moisture is next blotted off, the white backing paper gelatinized and squeegeed down, if necessary, and the glass set aside to dry. Any gelatine which gets on the face of the glass may be removed with a sponge dipped in warm water, preferably when dry.

BORDERS AND BACKINGS FOR OPALINES.

If the glass is not intended for hanging or standing up, the work may be finished by pasting thin, tough brown paper at the back, using the gelatine solution for the purpose. Hinged struts, having also a ring for hanging if desired, may be obtained: these should be attached with thin hot glue. The print and backing may be either cut to size before fastening to the glass, in which case allowance must be made for stretching, or the surplus paper may be trimmed off with a sharp knife after the opaline has dried. The latter method is probably the least troublesome. There are various ways of making fancy borders. The print may be trimmed smaller than the glass and the margin of the latter gilded, or differently tinted papers may be used; opaque black varnish is also very effective. Prints intended for mounting in optical contact should not be treated with alum or formalin. The gelatine solution does not keep very well, so it is not advisable to make it up in large quantities at a time.

ROLLING AND BURNISHING.

Prints on albumenised paper, P.O.P., and collodio-chloride, if not glazed or enamelled, are generally finished by rolling

or burnishing. These two operations are often spoken of as one, but strictly speaking they are quite distinct. Rolling consists of passing prints through a press having either two rollers or a roller and a flat plate, the polish resulting from the high pressure. Burnishing is performed by drawing the print between two heated rollers, or between a roller and a heated steel bar. The surface of the roller, plate, or bar against which the face of the print is drawn of highly polished nickel. Burnishing gives a greater degree of polish than that obtained by cold rolling. The bar burnisher is better in this respect than the roller burnisher, but has the disadvantage that the prints require lubricating, and are more likely to be scratched.

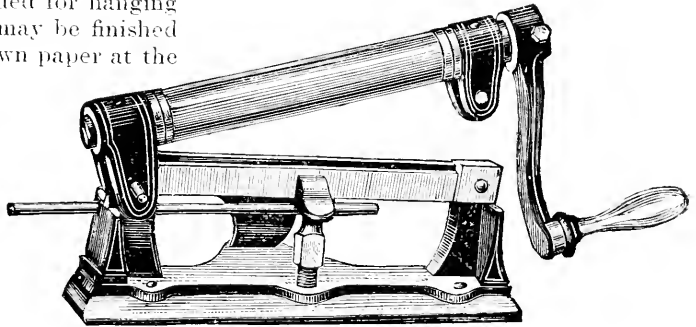

Fig. 408.—BAR BURNISHER.

THE BAR BURNISHER.

A typical pattern of bar burnisher, in which the upper roller may be raised, when it is desired to polish the bar, is illustrated by Fig. 408. In using the bar-burnisher the face of the print and mount should be rubbed over immediately before burnishing with a lubricant consisting of a few shreds of Castile soap dissolved in 1 oz. of methylated spirit. The bar must be made thoroughly clean and free from scratches by rubbing it from end to end with a piece of No. 0 sandpaper glued to a strip of wood. Replace the bar in position, and light the gas beneath the hot plate, keeping the top roller free of the condensed water constantly deposited on it. When the end of the plate hisses at the touch of the

moistened finger (for gelatine prints the plate should not be so hot), the burnisher is ready for use. See that the bar is properly adjusted, level, and at the correct distance from the roller. As this can only be roughly gauged by the eye, a spoilt but clean photograph should, as a trial, be passed through the burnisher. If the pressure is uneven, one side of the trial print will be more polished than the other side, and the bar must therefore be adjusted by the nuts under the plate until the pressure is correct. The print is in the best condition for burnishing when just

too hot the print will be scorched, and if too cold the glaze will be unsatisfactory.

ROLLER BURNISHERS.

Roller or roll burnishers, sometimes known as enamellers, are obtainable in many different patterns, for use with spirit, paraffin, or gas. Two patterns of gas-heated burnishers are shown by Fig. 409 and Fig. 410, the burners in each case being inside one of the rollers; the pressure is regulated by a screw at the side. Fig. 411 shows a model intended for use with paraffin. The pressure of the rollers is here adjusted by means of the two screws at the top. Fig.

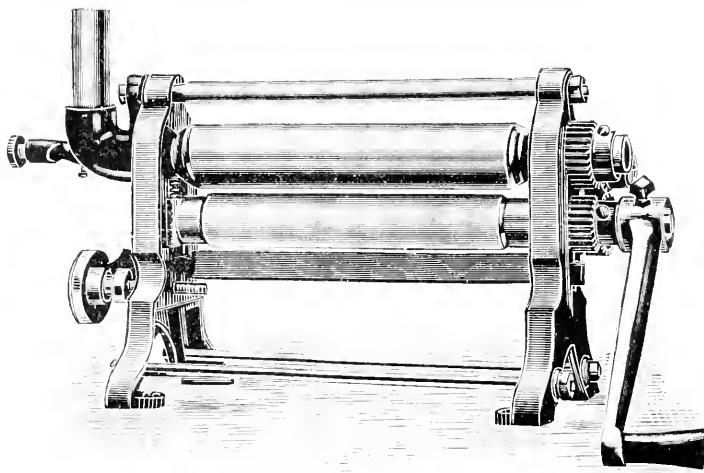

Fig. 409.—ROLLER BURNISHER FOR GAS.

surface-dry from the lubricant. If the print is too wet, it will blister, and if it is too dry the surface will have a cracked appearance. Prints cannot be properly burnished if they are kept for more than, say, one day after mounting. The print is taken by the edges, and passed through the burnisher in an upward direction, a slight drag being kept on the print. Reverse the print and again pass it through the burnisher. The print is better if slightly curled, as it will afterwards lie flat. Pass the print finally through the burnisher once in each direction, the long way of the print. This has a better effect, and the card is less likely to crack when curled in that way. If the burnisher is

412 illustrates the use of an outside gas-burner, with which some models are provided, and which are sometimes fitted to a spirit or oil burnisher, to adapt it for use with gas. This illustration also shows the method of curving the print while pulling through.

METHOD OF USING ROLL BURNISHERS.

Roll enamellers or burnishers act on the principle shown in the Diagram, Fig. 413. The prints should be dry, but not bone dry; the exact condition that gives the best results is rather difficult to convey in words, but the prints, if dried spontaneously in a room of normal temperature, should be fit to burnish in an hour. If the prints are too dry, they will yield a poor

surface, tending towards cracking, and if too damp, will blister and stick to the roller. A lubricator is not used on the prints. The rollers should be wiped occasionally during heating, in case any sweating occurs, which would cause the rollers to rust or the prints to blister.

of no value. Dust the print carefully, and, holding it face down, place one end between the rollers, which should be adjusted loosely, and wind through. Now tighten down the rollers until a fair grip, but not sufficient to disturb the face of the print, is obtained. The mounted prints

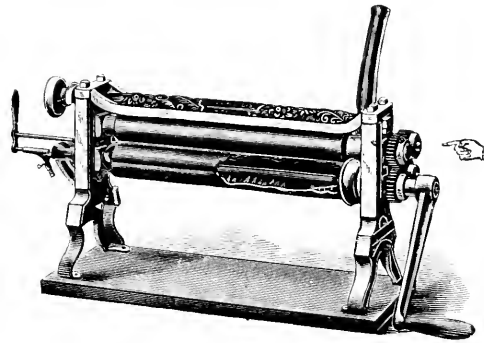

Fig. 410.—THE "GLOBE" ENAMELLER.

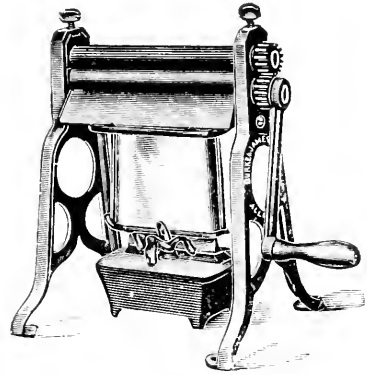

Fig. 411.—ROLLER BURNISHER FOR PARAFFIN.

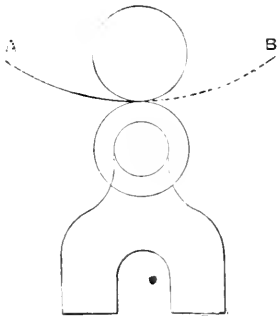

Fig. 413.—METHOD OF CURVING PRINT.



Fig. 412.—METHOD OF BURNISHING PRINTS.

Rub the rollers well with a perfectly clean dry cloth (revolving the handle meanwhile), then moisten the finger and touch the lower roller. If a hissing noise results, the roller is too hot; if the roller simply dries at once, the temperature is correct. Having adjusted the heat by the lever at the left side, test with a trial print that is

may now be passed through, once from each end and twice lengthways, and the result should be a high glaze without blisters or other defects. In passing the prints through lengthways, the mounts should, until halfway through, be bent slightly upwards as shown at A (Fig. 413), when the part B should be lifted by the

fingers, as shown, thus imparting a slight convex curve to the surface of the print. This curve will afterwards disappear and the prints will lie quite flat, but if the convex curve is omitted the prints will afterwards curl inwards.

GLAZING PRINTS.

A highly glazed surface may be obtained on gelatino-chloride or bromide prints by squeegeeing down to a highly polished surface and stripping when dry. Sheets of glass, ferrotype plate, or pulp slabs are used for the purpose. The prints should be well alumed or treated with formalin, and the glasses or ferrotype plates thoroughly cleaned with soap and water, dusted over with French chalk, and finally polished with a soft rag, every trace of the French chalk being removed. The photographs are taken direct from the washing water and laid face down on the glass or ferrotype plate, which is stood up for a short time to drain. The prints are next covered with several sheets of clean blotting-paper or a rubber pad and squeegeed down with a roller, till all the water is expelled from between the print and the glass, the plates or glasses then being hung up to dry. The prints must not be touched until they are bone-dry; they will then peel off spontaneously, or will do so on the insertion of a knife at one of the edges. Beeswax dissolved in turpentine or benzole is sometimes used instead of French chalk for polishing the glasses; it is smeared all over with a soft rag, and polished off with another.

MOUNTING GLAZED PRINTS.

As the glazed surface of the print would be injured or removed by again wetting it, a different method of mounting becomes necessary. A waterproof backing paper is obtainable which enables the prints to be mounted with starch without injury. A sheet of this backing paper is cut to the same size as the print, and pasted on the back of the latter before it has dried on the glass or ferrotype plate. The two come off together, when starch or any similar adhesive may be applied to the water-

proof back of the print as usual, care being taken not to allow any to get on the face. Ordinary thick paper is sometimes made to serve as backing, but in this case gelatine or glue must be used for mounting, applied to the edges only, for a width of about $\frac{1}{2}$ in. all round, with a small brush. Another method is to paste or glue the back of the print while on the glass, before it is dry, and to squeegee the mount down to it. If this is properly done, the print will come off ready mounted. Care must be taken that none of the adhesive gets over the edges of the print and on to the glass: if this happens, it must be removed with a damp sponge, or the mount will stick. Rather thin mounts are best for this method of mounting. Glazed prints may also be mounted with india-rubber solution or shellac, as previously described (p. 275): in which case backing is unnecessary. Another method is to harden the prints after washing in a 10-per-cent. solution of formalin, allowing them to remain in this for five minutes. They are then washed for three minutes, and at once squeegeed in the ordinary way. When stripped they may be placed in water and mounted with starch without fear of injuring the glaze.

ENAMELLING

The highest gloss obtainable on prints is that given by enamelling, an expression sometimes incorrectly applied to burnishing; the process consists in squeegeeing the print to a glass coated with collodion, and stripping when dry. For this purpose what is known as enamel collodion is used, the glasses being first carefully polished in the same manner as for glazing, and the collodion poured over like a varnish. The collodion film is then washed until all the greasy lines disappear, when the wet print is squeegeed over it. The glass is now stood up, and when absolutely dry the paper and film are stripped off together, the print appearing with an enamel-like surface. Another method is to immerse the print in a warm solution of gelatine, consisting of 2 drams of gelatine in 5 oz. of water, before squeegeeing to the collodion

film. This ensures a better adhesion of the collodion, and gives a finer gloss. Enamelled prints may be mounted in the same way as glazed prints.

ENCAUSTIC PASTE.

Encaustic paste is a wax polish applied to the surface of a mounted print as a substitute for burnishing. A small quantity is rubbed over the dry print with a soft rag, and polished off with a silk handkerchief. The following is a suitable formula: Pure wax, 500 parts; gum elimi, 10 parts; benzole, 200 parts; essence of lavender, 300 parts; and oil of spike, 15 parts. The ingredients are well mixed together to a thick paste, and put up in small pots.

MOUNTING ON CANVAS.

Canvas or other fabric strained tightly on a frame is used for mounting very big enlargements. The dry enlargement is laid face down and pasted on the back, the adhesive being well rubbed in. When the enlargement has become limp, the canvas frame is placed over it, and rubbed into contact from the back of the fabric. The edges are pressed down with a paper-knife or thin steel straight-edge, inserted between the frame and the canvas. This method of mounting is sometimes employed for photogravures and other prints having a plate-mark, which is not flattened or obliterated as it probably would be on a harder surface.

HOME-MADE MOUNTS.

Some photographers prefer to make their own mounts, treating each print separately to secure the greatest harmony and effect. Many varieties of thick tinted papers are obtainable for this purpose, and numerous artistic combinations may be made. The favourite method is to attach the print by the two upper corners to a sheet of tinted paper a little larger all round, so as to form a margin; and to fasten this in turn to a full-size sheet of a harmonising colour. If the print is on thin paper, or not flat enough to mount neatly by the corners only, a sheet of ordinary cardboard may be used as a foundation, the two layers of paper and the print being pasted in turn

on this, as in ordinary mounting. A narrow margin of black paper will often give an effective finish to a picture, but is unsuitable in many cases. Sometimes the best result is obtained by simply mounting the print on the plain tinted paper, without any margin. No hard-and-fast rules, however, can be laid down, for so much depends on the character of the picture and the taste of the worker. Much may be learned by studying the work of well-known photographers.

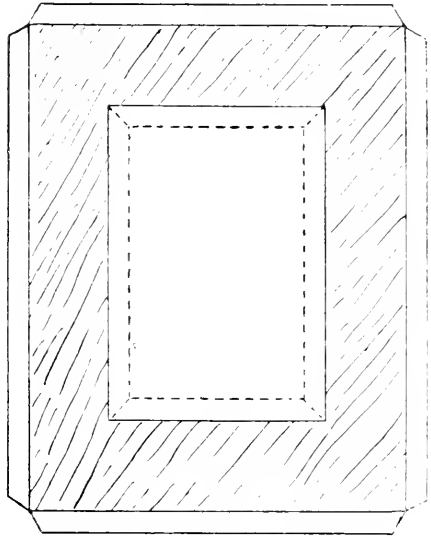

Fig. 414.—COVERING CUT-OUT MOUNT.

COVERING CUT-OUT MOUNTS.

Cut-out mounts may be made from any odd pieces of cardboard covered with tinted paper. Some very pleasing results may be obtained in this manner. The paper is cut rather larger than the mount, to allow for turning over the edges, and is attached with thin glue. Slightly damping the paper on the face will cause it to stretch tight in drying. When dry, the mount is turned face down, and the corners of the opening marked for turning over, as shown in Fig. 414. The mount having been placed on a clean sheet of glass, a square piece is cut away from the paper in the centre, as indicated by the dotted lines; the corners are then cut, and the paper is glued and turned over.

As each side is turned, the mount is lifted and the bevelled edges and corners are rubbed down neatly with a smooth paper-knife.

PASSE-PARTOUTS.

The passe-partout offers all the protection of a frame without being so expensive. A sheet of glass the size of the mounted picture is required, and a piece of cardboard for backing. The mounted print is placed between the glass and the cardboard, and the whole bound together by pasting or gluing a narrow strip of tough paper or American cloth round the edges. The binding strip may be about $1\frac{1}{2}$ in. wide, the greater portion being pasted at the back, so that only a narrow margin shows in the front. A neater finish is given by mitring the corners of the binding with a sharp knife, while sticking it down. Rings for hanging may be fastened to the back, if desired, before binding together. A slit having been made in the cardboard with a penknife, a short piece of tape is passed through a metal ring, and the two ends are then inserted in the slit and glued down on the other side; or the tape may be simply glued to the back of the passe-partout after binding, though this method is not so strong. A very pleasing effect is produced by treating a picture in a cut-out mount after this fashion; but the backing must be very thin, or dispensed with altogether.

FRAMING PHOTOGRAPHS.

Experience teaches that a frame which would be suitable for an oil painting or a brightly tinted water-colour drawing would completely spoil the effect of a photograph. Frames intended for photographs must be of a plainer and simpler description. Fortunately, there is a wide range of patterns to choose from, adapted to any given process or style of picture. The requirements of the professional differ slightly from those of the amateur; for the professional is bound more or less by the wishes of his clients, which are not always in accordance with good taste, while the amateur is able to give free play

to his fancy, and to choose his frames accordingly.

SUITABLE MOULDINGS.

For silver and P.O.P. prints plain frames of unpolished oak, with a narrow gold slip, are most suitable; A typical moulding of this kind is shown at A (Fig. 415). Reeded frames of varying widths, as B, C and D, are also adapted for the purpose. As a rule, a wide moulding gives a more impressive effect to the picture; but care should be taken that the width is not out of proportion to the size of the photograph. Bromide enlargements of a black tone look well in rather wide, dark carved oak moulding, of the type shown at E, F, and G, with a narrow gold slip if the print has a wide margin of mount, but not otherwise. Frames of green stained oak are also suitable for bromide prints of ordinary tone. Pictures of brown and other warm colours look best in plain wide mouldings of fumed oak, or oak stained to harmonise with the prevailing tone of the mount and photograph. When the prints are framed close up, without any margin, the gold slip is better omitted, at any rate with bromides and platinotypes in black. Other mouldings, H to T, are illustrated, of a more ornate and fanciful character.

STAINED WHITE-WOOD MOULDINGS.

Plain white-wood mouldings, stained in various colours, are much in favour. A good black stain is obtained by brushing over with a 10 per cent solution of sulphuric acid, and drying thoroughly. French polish and lamp-black, well mixed and rubbed in with a soft brush, is also recommended. An oak brown is made with a 50 per cent. solution of potassium permanganate; a walnut brown by mixing potassium bichromate $\frac{1}{4}$ oz., sodium carbonate $1\frac{1}{4}$ oz., vandyke brown $2\frac{1}{2}$ oz., and water 25 oz. A green stain may be made by dissolving verdigris in dilute acetic acid, or malachite green in methylated spirit; the latter, if treated when perfectly dry with a solution of potassium bichromate (about 5 per cent.), gives a bronze green of dull surface. Some very good stains may be made by mixing

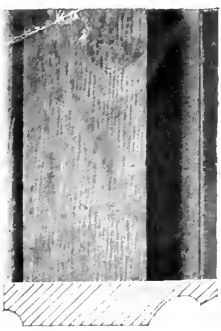

A

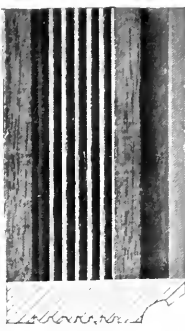

B



C



D



E



F

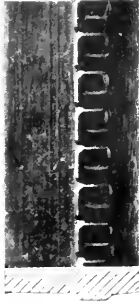

G



H



I

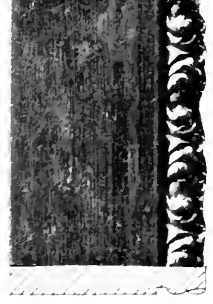

J



K



L

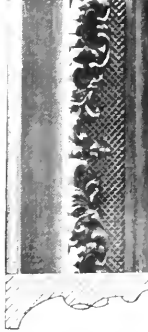

M

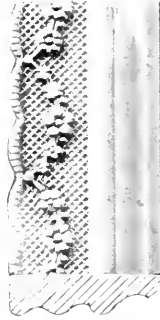

N



O

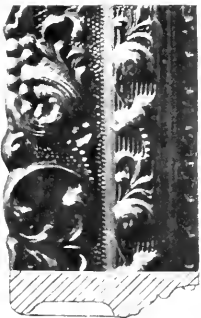

P

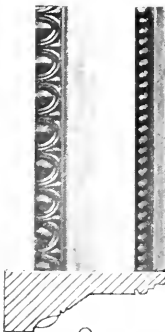

Q

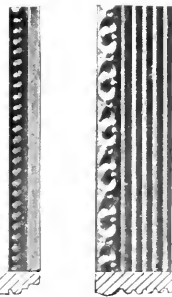

R



S



T

FRAME-MOULDINGS FOR PHOTOGRAPHS.

aniline colours or "Dolly" dyes to the required tint. These methods of staining give excellent effects on plain light oak mouldings, and are extensively used for that purpose. Varnishing should be done with a thin colourless medium, of not too bright a surface; many frames, however, look better without the varnish. A good wood polish can be made by dissolving 1 part of bleached lac in 7 parts of methylated spirit; this should be applied thinly and well rubbed.

FANCY MOULDINGS.

Fancy mouldings of composition, or having decorations of gold or silver, are extensively used by professionals; but from the point of view of fitness and artistic effect do not give the best results. The public, however, insist on having them, and the demand has to be satisfied. There are numerous patterns, perhaps the least objectionable being those with only a narrow inner margin of gilded or silvered ornament, with the remainder of plain, stained or polished wood, such as H and I in Fig. 415. This type of frame has a better effect when the mount of the print has a wide margin.

GOLD SLIPS

are not advisable, as a rule, except with prints having a good margin, or with photographs of a warm colour. They are quite unsuitable for close-framing black-toned bromides and platinotypes, for which a silver beading, if any, should be used. Gold flats are better made separately from the frame, to fit under the glass; this not only preserves the gilding, but allows the flat to be removed if it is thought that a picture would look better without it. The width of the slip is a question of some importance. A dainty, delicate print requires an extremely narrow flat; while a very large picture in a heavy moulding, or a vigorous and decisive print, needs a wide gold slip.

GLASS FOR FRAMING.

The glass must be of good quality, and free from bubbles or flaws. If any of these

are present, they should be made to come where they will least affect the picture. Old negatives from which the film has been cleaned are suitable, when large enough, as they are usually made of carefully selected good quality glass. Glass with a greenish tinge should not be used. Cutting is readily done with a glazier's diamond or a wheel-cutter. The glass is laid on a flat surface, and, the required dimensions having been ascertained, a straight-edge is held in position on the glass, and the cutter drawn firmly, but without too heavy a pressure, along the edge of the ruler. The aim is to make a visible nick or scratch on the glass—with one stroke if possible. The glass is then taken in both hands, with the nick or scratch on the upper surface, and given a sharp twist downwards on both sides at once, when it should break neatly along the mark. The remaining sides are cut in the same manner, a T-square being used to secure right angles. When two sides have been cut, the glass may be laid over the back of the frame, and the other sides marked from that, to ensure having it the correct size.

FIXING THE PICTURE IN THE FRAME.

Thin wood for backing may be procured at the frame-maker's, in 6-foot lengths, for a few pence, or stout cardboard may be used. The glass having been well cleaned on both sides, and laid in the frame, the mounted print is placed face down on the glass, and over this the backing. Two or three picture brads should be loosely driven in, and the frame turned over to see if the picture is correctly placed and that no pieces of fluff or grit have got between it and the glass. If everything is all right, the frame is laid face down again and the nailing completed, pressing firmly but not heavily on the backing while driving in the brads, for which purpose a small tack hammer is best. A sheet of thin, tough brown paper, a little smaller than the frame, is now cut and damped on one side with a sponge, the other side being well pasted. The paper is then rubbed down on the back of the frame. The damping of the paper causes it to stretch tight when dry.

CORDS AND RINGS.

If the picture is to be hung, small rings are screwed in at the back. The position of these rings is shown in Fig. 416. The cord is passed through both rings, and the two ends tied together at the back, as shown, when the length of the cord may be adjusted as desired. For heavy frames, stout picture wire is sometimes preferred. Frames intended for photographic exhibitions are seldom hung with cords and rings, but are provided with a pair of

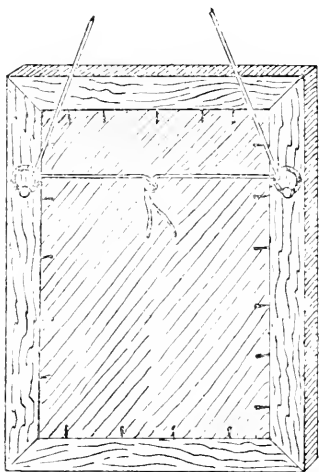

Fig. 416.—METHOD OF ATTACHING CORD AND RINGS.

mirror plates (see Fig. 417); these are screwed to the back of the frame, the picture being fastened in position by means of small nails or screws driven through the outside holes in the mirror plates.

FRAME-MAKING.—CUTTING MOULDING.

Frame-making is by no means difficult. The tools required are a mitre-block (Fig. 418), a mitre-shoot or shooting-board (Fig. 419), a tenon saw, and a jack plane. The moulding is placed on the mitre-block face down, with the rebate to the front; the tenon saw is then placed in the right-hand cut of the block and the moulding sawn at an angle of 45° . The length is next measured from the back of the rebate, allowing about $\frac{1}{8}$ in. for cleaning off, the

moulding this time being placed against the left-hand cut of the block and sawn through as before. The other three sides of the frame are cut in the same way.

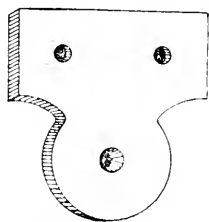

Fig. 417.—MIRROR PLATE.

TRIMMING THE MITRES.

The moulding is placed on the proper side of the shooting-board (see Fig. 419), and held firmly with one hand. The jack plane, lying on its side in the rebated portion of the shooting-board, is then pushed

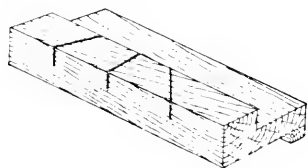

Fig. 418.—MITRE BLOCK.

with the other hand against the mitred edge of the moulding, so as to take off a thin shaving. The opposite mitre is treated in the same fashion on the other side of

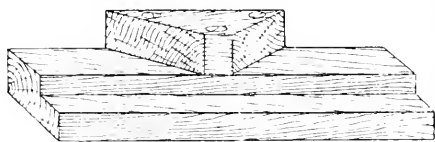

Fig. 419.—SHOOTING BOARD.

the shooting-board, the plane, of course, being held in the other hand. It should be seen that the corresponding or opposite pieces of the frame are exactly equal in length.

GLUING AND NAILING.

For gluing-up the frames, a corner cramp is of great service. This is made in

different forms, one of these consisting of four small wooden blocks or angle-pieces which fit on the corners of the frame. A stout cord passes through these blocks, and at one of the corners means are provided for tightening the cord by a thumb-screw. The mitres of the frame having been well glued, the wooden blocks are fitted to the corners and the thumb-screw tightened, the frame being thus held firmly together till the glue has set. Cramping vices are also obtainable; these hold two pieces of moulding tightly in position, thus enabling the gluing and nailing to be done at one operation. Another method is to tie the frame round fairly tight with string; and then to force in seven or eight small wooden blocks, as shown in Fig. 420. To prevent the string marking the moulding, pieces of folded paper may be placed over the corners. When the glue is perfectly dry, the corner cramp or string is removed, and the angles nailed with small brads. Gilt slips are made in the same way, but it is generally sufficient simply to glue the corners. If properly made, they will fit tight in the rebate of the frame, without any other fastening.

MITRING CORNER ORNAMENTS.

Sometimes a frame is finished off by the addition of ornamental corners, though this is hardly a suitable method of treatment for photograph frames. The corners are generally glued on, after very careful mitring. Such work is better done with a fretsaw than with a tenon saw, and the edges require to be smoothed with glass-paper. Care must be taken that the pattern is cut so as to join without spoiling the symmetry of the design. Corner ornaments are now obtainable already mitred. Brass, copper, or iron corners in repoussé work are more adapted for the decoration of photograph frames than those consisting of gilt or composition ornament. Metal corners are best attached with small round-headed nails of the same metal. Holes should be first started for these with a bradawl, or there is a likelihood of splitting the moulding.

FLORENTINE FRAMES.

Carved and gilt Florentine frames, though extremely beautiful in themselves, are unsuited for any but coloured photographs. For these, however, they afford a handsome and effective finish. They certainly offer the best method of treatment for miniatures, water- and oil-coloured prints, and enlargements. Gilt frames of any description, in fact, may be used for photographs finished in colours, provided that the moulding is neither too heavy nor too insignificant for the picture. Another point to be remembered is that the style of the ornament on the frame should not be inconsistent with the character of the picture.

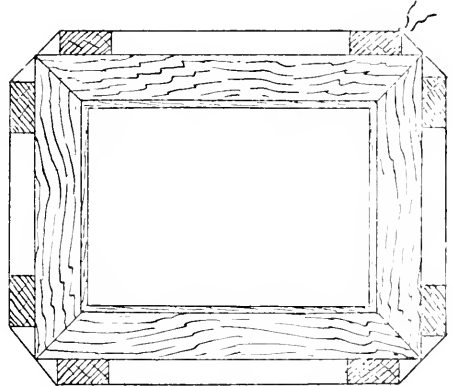

Fig. 420.—METHOD OF PLACING BLOCKS.

DUST-PROOF BINDING.

This consists of pasting a narrow strip of brown paper round the edges of the picture and glass, before framing, after the manner of a *passe-partout*. The plan is strongly recommended, as dust is absolutely prevented from getting to the picture. Four strips of brown paper about 1 in. wide are pasted round the outside edge of the glass, forming a border not more than $\frac{1}{4}$ in. wide. The paper is bent over, and the glass placed in the frame. Then the picture is inserted, carefully adjusted in position, and the brown paper folded over and pasted down to the back of the picture.

MOUNTING ON WOODEN PANELS.

Panels of close-grained wood may be used for mounting with good effect. The print should be one of a broad and striking character, on thick rough paper; thin glue is the best adhesive to use. The print is mounted dry, and well rubbed down with a roller squeegee. This method of mounting proves very satisfactory for mural decoration, particularly if the print is varnished. Before applying the varnish, the print must be given a thin coating of size, the varnish then being carefully applied with a soft, wide camel-hair brush. A colourless varnish should be used, and preferably this should be of a hard and not too glossy character.

ALBUMS.

Prints in albums should be mounted dry with a gelatine mountant, as this will not cause the leaves to cockle so much. An album for pasted down pictures should have thick cardboard pages. Very convenient slip-in albums are now obtainable, which do away with the trouble of mounting. Those with leaves of different tints, and with various sizes and shapes of openings, are the most useful, unless the prints are uniform in style and dimensions. Loose prints mounted on tinted papers may be made into an attractive album by stringing them together with silk cord. Three holes are made with a bradawl at the left side of two stout boards, covered with any suitable material, with a piece of vellum or American cloth for a back or hinge. The prints are similarly perforated, the silk cord being passed through the holes and tied in a bow at the front.

FANCY MOUNTING.

Platinotype prints are often mounted right up to the edge of a stout mount, which is bevelled and then attached with glue to another thinner grey board. It is very effective, but the centre board is liable to curl and crack off. Gelatine and

albumen prints were at one time enamelled and mounted with a raised centre. A print was enamelled with collodion, a piece of cartridge paper affixed to it, and then put in a cameo or other press and stamped so as to raise the centre. The edges were then attached with glue to a card, and the hollow of the raised centre filled in with a pad of cotton-wool.

MATT SURFACE ON PRINTS.

A matt surface is best obtained by using a matt paper, but glossy P.O.P. may be dried with a matt surface by squeegeeing to a sheet of fine ground glass, in the same manner as for producing a glazed surface (see p. 286). A matt surface may be given to a print after mounting it by rubbing it gently all over with very fine pumice-powder until the glaze entirely disappears. The print must be bone-dry, and the rubbing done patiently and carefully. The pumice-powder is afterwards dusted off with a soft rag. This method gives an excellent matt surface without injury to the print, which is very susceptible, however, to damage by damp or moisture.

FLATTENING UNMOUNTED PRINTS.

The dry print should be laid face downward on a sheet of blotting-paper: the edge of a smooth paper-knife is then pressed down on it with one hand, while with the other the print is pulled away from it, curling it slightly up. This is repeated in different directions, until the print no longer curls. The best way of storing unmounted prints is in a flat blotting-book under pressure. Albumenised prints may be taken from the washing water, drained, and blotted off between two sheets of clean blotting-paper. They are then laid out to dry, face downward, on a clean linen cloth. When just dry, they are rolled, face outwards, on a wooden roller, one over the other. After a day or two they may be removed, and will then have little tendency to curl inward. This method is not suitable for prints on printing-out paper.

CONCLUDING REMARKS ON FRAMING.

It has been well said that, in the framing of photographs, the print should be considered first, the mount (if any) second, and the frame third. This may seem to be giving undue importance to the mount; but a little reflection will show that, being nearest to the picture, it must necessarily play a greater part in the general effect than the frame, or at any rate should do so. Attention should be paid to obtaining the proper degree of contrast between

the frame, picture, and mount. To put a yellowish print on a blue mount, for example, would simply make it look more yellow; and to place a poor grey picture in a black frame would only serve to show up its weakness. On the other hand, a cold-coloured mount heightens the effect of a warm print, while a reddish or brownish mount gives additional blueness to a print of cool tone. All these points have to be carefully studied if it is desired to secure the best and most artistic effect, combined with complete unity and harmony.

PINHOLE PHOTOGRAPHY.

INTRODUCTION.

THE idea of obtaining negatives without the use of a lens seems, at first sight, somewhat strange; it is not only possible, however, but the application of a principle recognised as early as the beginning of the sixteenth century, when Baptista Porta pointed out that images of external objects were formed on a screen placed in a darkened room or box, through a minute hole in the wall opposite the screen: such images are frequently to be seen on the ceiling of a room through the comparatively large holes in a venetian blind, or even through a keyhole, on the opposite wall of a room. In both these cases the images are confused and appear more like shadows, but they are nevertheless true camera images, for to obtain clear images the small holes have to be a definite size, or rather must bear, within certain limits, a ratio to the distance between the hole and the screen, wherever the image is formed.

ADVANTAGES OF PINHOLE WORK.

It may reasonably be asked, What are the advantages of pinhole photography, and what its disadvantages? The images obtained in a pinhole camera, in the first place, possess pleasing softness of outline, there is no distortion, and, most important of all, any angle may be included, that is to say, no matter how one is cramped for room, one can always include the desired amount of subject. For instance, it is well known to all photographers, that to include the whole of a very tall building on a plate, when one cannot get far away from it, as in a narrow street, a lens of extremely short focus, or a

wide angle lens, must be used. With the pinhole, it is only necessary to place the plate at the required distance from the hole and we are certain of including the whole of our subject. Under precisely the contrary conditions, too, the pinhole has an advantage; for supposing we wish to obtain a photograph of a building or other object a long way off, if we have only one lens we are absolutely limited to the size which that lens will give, whereas with the pinhole, we have merely to increase the extension of the camera, or the distance of the plate from the pinhole, and we can obtain an image as large as we require.

DISADVANTAGES.

The disadvantages are that the definition is not critically sharp, and in consequence of the prolonged exposures necessary, it is impossible to take moving objects; but, with these exceptions, there is practically no work which may not be done with a pinhole, for landscape, architecture, portraits, the copying of pictures or other still life objects, enlarging and reducing, all fall within its province; and from the fact that within certain limits a pinhole has no focus, or rather plane of critical focus, as shown by the fact that results almost indistinguishable from one another as regards definition, can be obtained, with a given aperture at any distance from 2 to 5 in., and with larger apertures in like ratio, it is obvious that there is a wide field open to it.

SUITABLE CAMERA FOR PINHOLE WORK.

Any ordinary camera may be used for outdoor work, and so may any light-tight box, or any box which can be made temporarily light-tight, as by wrapping in a

black cloth, for indoor work, and the advantage of the latter is that one is not limited to size, as almost any box may be pressed into service, provided it can be made light-tight and the plate supported in an upright position, as by means of a printing frame, or four drawing-pins stuck into the end of the box, etc. Thus for small sizes an empty cigar box becomes very handy.

FOCUS OF A PINHOLE.

It has been stated above that within certain limits a pinhole has no focus, and also that its diameter must bear some ratio to the distance from the plate. There is considerable disagreement as to the best aperture for a given focus, and whilst not attempting to enter into the theory of the subject to any extent, it is advisable that some rules be given by which any photographer can find the aperture for a given focus and the reverse.

ABNEY'S RULE.

From certain mathematical calculations of the optical phenomena which take place when light passes through a minute hole, it has been determined by Sir Wm. Abney that the following very simple formula will give the diameter of the pinhole for any given focus: $\sqrt{f \div 120}$, in which f = the focus; inversely, of course $(120 \times d)^2 = f$, in which d is the diameter of the pinhole. An example may make this quite clear: Suppose we have a pinhole the diameter of which is $\frac{1}{10}$ of an inch, then the best focal length or distance from plate is

$$(120 \times \frac{1}{10})^2 = 3^2 = 9 \text{ inches};$$

and if we have a focal length of 25 in., the best diameter of pinhole is

$$\sqrt{25 \div 120} = 5 \div 120 = \frac{1}{24} \text{ inch.}$$

Other formulae have been given, and other results have been arrived at; but the above is simple and easy to calculate, and has been found satisfactory in practice, though the distances may be halved or doubled, in the above or any case, without much difference being noticed.

DEPTH OF FOCUS.

It follows from what has been said at the conclusion of the last paragraph that a

pinhole possesses what is called great depth of focus, and this is, in fact, so great that it may be practically ignored, for according to the well-known law relating to this subject, the nearest point in focus with an aperture of $\frac{1}{10}$ of an inch and 9 in. focus would be about 32 in., a distance within which one is not likely to include an object.

DIAMETER OF HOLE AND EXTENSION.

In order to save calculation the following table has been worked out by the previously mentioned rule, which will enable anyone to choose the best aperture for any focus, or best focus for any aperture.

TABLE OF FOCI OF PINHOLES.

Size of Pinhole.	Correct focus.	Ratio Aperture.
$\frac{1}{100}$ inch.	$1\frac{1}{2}$ inches.	$f/150$
$\frac{1}{90}$ "	2 "	$f/180$
$\frac{1}{80}$ "	$2\frac{1}{4}$ "	$f/225$
$\frac{1}{70}$ "	3 "	$f/210$
$\frac{1}{60}$ "	4 "	$f/240$
$\frac{1}{50}$ "	5 "	$f/250$
$\frac{1}{45}$ "	7 "	$f/315$
$\frac{1}{40}$ "	9 "	$f/360$
$\frac{1}{35}$ "	$11\frac{3}{4}$ "	$f/411$
$\frac{1}{30}$ "	16 "	$f/480$
$\frac{1}{25}$ "	23 "	$f/575$
$\frac{1}{20}$ "	36 "	$f/780$

TABLE FOR HALL & CO.'S NEEDLES.

Unless one has, however, extremely accurate drills, and means of microscopically measuring the holes obtained, it is far better to use ordinary sewing needles; and Mr. Alfred Watkins has given the following useful table of the numbers and diameters of the needles made by Hall and Co., of Sudley, and also the best focus and the ratio apertures:—

No. of Needle.	Diameter.	Focus.	Ratio Aperture.
1	$\frac{1}{22}$ inch.	32 inches.	$f/700$
2	$\frac{1}{23}$ "	28 "	$f/610$
3	$\frac{1}{24}$ "	23 "	$f/600$
4	$\frac{1}{25}$ "	20 "	$f/560$
5	$\frac{1}{26}$ "	15 "	$f/460$
6	$\frac{1}{27}$ "	13 "	$f/440$
7	$\frac{1}{28}$ "	10 "	$f/390$
8	$\frac{1}{29}$ "	8 "	$f/350$
9	$\frac{1}{30}$ "	6 "	$f/290$
10	$\frac{1}{31}$ "	5 "	$f/270$

TABLE FOR KIRBY & Co.'s NEEDLES.

Mr. E. J. Wall has given the following table, calculated in the same way, for some needles made by Kirby and Co. :—

No. of Needle.	Diameter.	Focus.	Ratio Aperture.
2	$\frac{1}{15}$ inch.	23 inches.	$f/575$
3	$\frac{1}{17}$ "	20 "	$f/549$
4	$\frac{1}{19}$ "	15 "	$f/465$
6	$\frac{1}{27}$ "	12 "	$f/420$
7	$\frac{1}{32}$ "	8 "	$f/336$
9	$\frac{1}{36}$ "	6 "	$f/300$
10	$\frac{1}{37}$ "	4 "	$f/240$
12	$\frac{1}{41}$ "	21 "	$f/187$
16	$\frac{1}{54}$ "	14 "	$f/125$

Of course, in both tables, as far as possible round figures have been given, and not the exact ones, which would be bewildering on account of the minute fractions.

FINDING DIAMETER OF NEEDLE.

To those who may have other makes of needles, there is a very simple plan of obtaining the diameter, which is more accurate the more needles are used: Remove the needles from the packet and place them side by side on a perfectly smooth flat surface, such as several sheets of writing paper or a piece of glass, and then pressing them close together, but taking care that they do not overlap, measure as exactly as possible what space they cover, then by dividing this by the number of needles, one obtains the diameter of each: for instance, a French make of No. 6 was found to have a diameter of $\frac{1}{33}$ in.; for thirty-three just measured an inch; with a German make of the same number this was found to be $\frac{1}{32}$ in. For those who wish to work with great accuracy, metal gauge plates may be obtained commercially, which show exact measurement.

MAKING THE BOSS.

The operation of making a satisfactory pinhole is not such a simple matter as, at first sight, it would appear, for certain conditions should be observed which are by no means easy. In the first place, the

hole must be circular, with perfectly clean edges, and it should have no thickness, that is to say, the thickness of the material should be at the edges of the hole less than the diameter of the hole itself. The necessity of this will be obvious when one thinks how small the holes are, and that any appreciable thickness at the edge would give precisely the same effect as photographing through a tube. As an exaggerated example, supposing we take an aperture of $\frac{1}{61}$ of an inch, made in a sheet of metal a sixteenth of an inch thick, we should have precisely the same result as though we used an aperture of one inch and a tube four inches long; that is to say, the angle of view, or amount of subject included, would be limited. Besides this, there are other considerations, such as reflections from the interior of such a tube, which play an important part when dealing with such minute apertures. The most satisfactory material for making pinholes would be tinfoil, were it only strong enough to stand any handling. Very thin sheet brass or copper is most serviceable, though if one has a small Archimedean drill, metal up to one sixteenth of an inch or more may be used, because one can countersink it and drive the hole through the middle. If thin brass, such as used for stencil plates, be used, it is advisable to make first a small boss in the centre by bearing heavily, or lightly tapping with a hammer, on some round pointed stick. A good-sized penholder is a capital thing, though an ordinary lead pencil may be employed first to make a fairly large boss, and then a more pointed instrument used in the centre of this. The metal should be supported on something yielding; a dozen sheets of good thick blotting-paper is an excellent thing.

MAKING THE NEEDLE HOLE.

Although this branch of photography is called "pinhole" work, it will have been noted that all along needles are recommended to make the holes. Small needles are extremely difficult to handle, and the best thing to do is to procure two or three penholders, cut them in

half, and then, holding a needle with a pair of fine pliers, force the eye end into the soft wood of the holder; this gives one a purchase. The numbers of needles should, of course, be marked on the handles. Having made the boss on your metal plate, take a needle of the required size and gently but firmly press the point through the centre of the boss, and as soon as it protrudes on the other side, withdraw it and insert from the opposite side to that on which you first began, till it will go a little further in; then turn the metal over and pass the needle well through the hole from the original side, till it will move freely. Do not waggle the needle from side to side; it must be applied with a straight steady push. If the hole is now examined with a magnifying glass it will be found to have a rough edge or burr of metal; this must be removed, either by means of a sharp penknife or gently rubbing down on an oilstone. After each application of the hone or knife, the needle must be again passed through, till no burr is seen. With a little care very good pinholes may be thus made, and they only need mounting to be complete; though it is preferable to blacken them, which is best done by holding them over a small piece of burning sulphur. The size of the hole should be scratched on the metal.

METHOD OF MOUNTING PINHOLE.

If an ordinary camera and lens are in the possession of the would-be pinhole worker, all that is required is to obtain from a chemist a purple pill-box, cut out the bottom, and the centre of the lid; then cut the brass into a circular form, with the pinhole in the middle, of just such a size that it will slip into the pill-box lid, and the bottom rim of the box pushed into its place will keep it steady; or it may be glued to any circular piece of card and this slipped into the lens tube, up against the stop, the lenses themselves being of course removed. If a box is specially made, then the card bearing the pinhole may be temporarily or permanently attached to it by glue or drawing-pins, or any other device that may suggest itself,

the only caution being to see that it is light tight.

BEST APERTURES FOR VARIOUS KINDS OF WORK.

Although the sizes of various needles have been given, with their corresponding foci, for all practical purposes $\frac{1}{50}$, $\frac{1}{5}$, and $\frac{1}{100}$ will be quite enough to meet every requirement, and can be used with any extension of camera from 2 up to 30 in. The largest hole will be most useful for all outdoor work, the medium size for architecture, exteriors only; for interiors the largest hole should be used and some definition be sacrificed, so as to shorten the exposure; the smallest pinhole is for copying, and for very short focus work.

ESTIMATING EXPOSURE.

It will be noticed in the tables that the "ratio aperture" of the pinholes is given, and for a certain extension of camera; if any other extension be used, the ratio aperture must be found in the usual way, that is, by dividing the focus or extension of camera by the aperture. For instance, if the extension of the camera is 12 in., and the aperture $\frac{1}{50}$, the ratio aperture will be $f/600$. It is necessary to determine this, because the ratio aperture is an important factor in determining the exposure, and as regards this in pinhole work the usual law is followed, namely, that the exposure is as the square of the apertures; thus, if with a lens working at $f/8$ with a given plate, the exposure was $\frac{1}{4}$ second, with $f/600$ it would be as $(8 \times 8) : (600 \times 600)$, or as $64 : 360,000$; therefore if 64 requires $\frac{1}{4}$ second, 360,000 would obviously require 1,460 seconds, or practically 24 minutes.

ASCERTAINING AMOUNT OF VIEW.

The pinhole having no definite plane of focus, it is obviously unnecessary to focus on the ground glass of the camera, to see whether the image is sharp; but one may want to know how much is included in the view with any given extension of camera. It is useless attempting to learn this by an examination of the focussing screen, for

the illumination of the image is so feeble that it is impossible to see it. It has been suggested that the operator should provide himself with spectacle lenses of foci corresponding to the extensions of the camera, temporarily mount one of these, and then examine the screen: but unless one were to carry a whole battery of spectacle lenses, it limits one to a few extensions only. By far the most sensible plan is to take a piece of opaque cardboard, just large enough to slide into the grooves in which the dark slide is usually carried, and in the card cut an aperture the size of the plate that is used. Now turn back the focussing screen, out of the way, slide in the card, and turn this end of the camera to the view you wish to take: then by removing the pinhole and using a piece of card with a hole of about $\frac{1}{4}$ in. diameter, one can easily see exactly how much subject is included in the rectangle cut in the card that is in the dark-slide groove, and if more or less subject is desired, the camera extension must be shortened or lengthened.

PHOTOGRAPHING HIGH BUILDINGS.

Two rules have been given by the Rev. J. B. Thomson, of Greenock, which are useful under certain conditions. Suppose, for instance, we wish to take a high building or monument, the height of which we know, then the following rule will tell us how far off we must place the camera in order to include the whole of the building, when working with a given plate distance or extension of camera: As is the height of the needle-hole above base of front (inside) to the plate distance, so is the height of the object to the proper camera distance. Suppose the monument measures 100 ft. and the extension of the camera is 10 in., then we have, As 5:10::100:200; but we must allow a little for margin in our picture, so we allow another 10 or 20 ft. Another useful rule is how to find the plate distance, when height of object and working distance is known: this is: As is the height of the object to the height of the needle-hole above the base (inside), so is the distance of the object to the proper

plate distance. Taking the last figures, that is, 100 ft., as the height of the building, 5 in. as the needle-hole height, and the working distance, that is the greatest distance we can get away from the building, as 50 ft., then we have, As 100:4 $\frac{1}{2}$::50:2 $\frac{1}{2}$. Here again, a little allowance must also be made for margins. Unfortunately, we rarely know the height of a building or monument, so that the previous plan of turning the camera round is preferable.

LIMITS TO LATITUDE OF EXTENSION.

It will have been gathered from what has been said that there is enormous latitude as regards the distance of the plate from the pinhole, but there are theoretical objections to using too short a plate distance, if the size of the plate is kept constant: for it will be obvious to all that the distance between the pinhole and the centre of the plate will be much shorter than from the pinhole to the extreme corners, and as light decreases in power as the square of the distance, it is obvious that the falling off of illumination at the corners or edges of a large plate with a short focus will be noticeable, so that, unless under stress of circumstances, the focus for any given sized pinhole, as given in the tables, should be adhered to as nearly as possible, or within reasonable limits.

ENLARGING AND COPYING.

It has been stated that a pinhole may be used for copying and enlarging, and for such work the smallest pinhole, about $\frac{1}{100}$ of an inch, should be used, and the focus considered as some round number, which may, for convenience sake, be taken as the nearest whole number less than the longer side of the plate we use; thus, 4 in. for a quarter-plate, 6 in. for a half-plate, and so on. The convenience of this is obvious when we come to use the following table, which gives the relative distances between pinhole and subject, and pinhole and plate, when enlarging, reducing, or copying. If one uses a box with a fixed distance, say 6 or 8 in., then one must reckon the distance to place the camera from the picture

or subject to be copied, and this is very easy; for instance, suppose we determine on 6 in. as the plate distance for a half-plate, and we want to copy a picture 24 in. long; well, allowing for margins, we should reduce this to 6 in., or one-fourth—therefore, the distance between the picture and pinhole should be four times our plate distance, or 24 in. The rule, therefore, is

very simple: multiply the fixed plate distance by as many times as you reduce the size of the object, and the result will be the distance between pinhole and subject. For a variable or focussing camera, use $\frac{1}{7}$ or $\frac{1}{10}$ inch aperture and consider that the true focus is as stated above, then the annexed table will give the relative distances for enlarging and reducing, or copying. Not much explanation is wanted of these figures, as each column is explained by the words above or below. The numbers are but ratios, and if the focus of the pinhole is fixed at a given distance, then this must be multiplied by the figures in the tables to obtain the necessary enlargement or reduction.

TABLE FOR ENLARGING, REDUCING AND COPYING.

Enlargement.	Distance from Pinhole		Relative Exposures.	
	to Subject.	to Plate.	Enlargement.	Reduction.
Same Size	2-00	2-00	1-00	1-00
1-1 times	1-91	2-10	1-10	0-91
1-2 ..	1-83	2-20	1-21	0-86
1-3 ..	1-77	2-30	1-32	0-78
1-4 ..	1-72	2-40	1-44	0-74
1-5 ..	1-67	2-50	1-56	0-70
1-6 ..	1-62	2-60	1-69	0-66
1-7 ..	1-59	2-70	1-82	0-63
1-8 ..	1-56	2-80	1-98	0-61
1-9 ..	1-50	2-90	2-10	0-58
2-0 ..	1-48	3-00	2-25	0-56
2-1 ..	1-45	3-10	2-40	0-55
2-2 ..	1-43	3-20	2-56	0-53
2-3 ..	1-42	3-30	2-72	0-51
2-4 ..	1-40	3-40	2-89	0-50
2-5 ..	1-38	3-50	3-06	0-49
2-6 ..	1-37	3-60	3-24	0-48
2-7 ..	1-36	3-70	3-42	0-47
2-8 ..	1-34	3-80	3-63	0-46
2-9 ..	1-33	3-90	3-80	0-45
3-0 ..	1-31	4-00	4-00	0-44
3-2 ..	1-29	4-20	4-41	0-43
3-4 ..	1-28	4-40	4-84	0-42
3-6 ..	1-26	4-60	5-29	0-41
3-8 ..	1-26	4-80	5-76	0-40
4-0 ..	1-25	5-00	6-25	0-39
4-5 ..	1-22	5-50	7-56	0-37
5-0 ..	1-20	6-00	9-00	0-36
5-5 ..	1-19	6-50	10-56	0-35
6-0 ..	1-17	7-00	12-25	0-34
7-0 ..	1-14	8-00	16-00	0-32
8-0 ..	1-12	9-00	20-25	0-313
9-0 ..	1-11	10-00	25-00	0-308
10-0 ..	1-10	11-00	30-25	0-300
Reduction.	to the Plate.	to the Subject.	Enlargement.	Reduction.
	Distance from Pinhole		Relative Exposures.	

CONCLUDING REMARKS.

A plate exposed in a pinhole camera requires no different treatment in the subsequent operations to one exposed in the ordinary way, and as this is fully explained elsewhere, farther details are unnecessary. Plate XI. (facing page 145) gives two good examples of pinhole landscape work, by R. H. Baskett, a well-known pictorialist. Indeed, it is for pictorial work that the pinhole is especially suitable, on account of its soft definition and diffusion of focus, which lend themselves admirably to atmospheric effects and artistic rendering of tone values. It is, however a delusion that pinhole pictures cannot be obtained of satisfactory sharpness: for, providing a sufficiently small hole is used, and the subject chosen is suitable, the definition of the resulting negative will be such that it might readily pass for one taken with a lens; although, of course, *extreme* fineness of detail is not to be expected.

ENLARGING, COPYING AND MAKING LANTERN SLIDES.

ENLARGEMENTS AND DIRECT PICTURES COMPARED.

It has always been a debatable point as to whether the best results are obtained by direct photography or by enlarging. Some workers claim that greater detail and more roundness and gradation are obtained in the direct negative; while others consider that a more correct image in better perspective is obtained by enlargement. In skilful hands, the former is certainly the best method, but it is inconvenient for obvious reasons to take very large pictures direct. The usual plan is to use the direct method for anything up to 12 in. \times 10 in. or 15 in. \times 12 in., and the enlarging method for sizes above that. In large portrait studios, negatives are taken up to 30 in. \times 20 in. direct; but the advantage in ease and simplicity will be apparent at once when one remembers that in photographing direct a negative of the full size has first to be made on glass, whilst an enlargement may be on a paper support. These considerations can only be taken into account when the exact size of the finished picture has been decided upon before commencing. Where a large number of copies are required, the proper plan is to make an enlarged negative; but, if only one copy is needed, an enlarged print may be made. The advantage of the negative is that all the prints may be made the same, whilst, if the negative is carefully retouched, it may be made to give prints which require very

little working up. Either enlarged negatives or positives may therefore be made, the method differing only slightly in each case.

PROCESSES AVAILABLE.

Any of the development processes of either printing or negative making may be employed for enlarging, and, in certain cases, even the printing out methods. These latter, however, require special apparatus, and are done by a different method, which will be referred to later under the heading of solar enlarging. The most popular method of enlarging is by the bromide process, or upon bromide paper, and will therefore be first described.

APPARATUS.

The form taken by the apparatus is dependent upon the illuminant chosen, that is, whether daylight or artificial light, although the optical principles are the same in each. Whenever daylight can be employed, it is far preferable to any form of artificial illumination. The results are always softer, and have better gradation; whilst, if the negative has been retouched, there is always great danger of the pencilling being very apparent when artificial light is used. Owing to these facts, artificial light is little used by professional workers, except during the dull days of winter; while amateurs usually favour it as affording opportunities of working at more convenient times.

DAYLIGHT ENLARGING APPARATUS.

Fig. 421 shows the simplest form of daylight apparatus, suitable only for amateur use and for small sizes. It consists merely of two boxes, or one box divided by a partition carrying a lens, which may be any ordinary one used in the photographer's camera. The top A has an opening c to take a quarter plate or smaller size negative, and the bottom B carries a printing frame for holding the sensitive

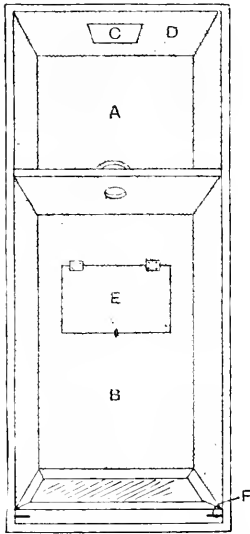

Fig. 421.—SIMPLEST FORM OF DAYLIGHT ENLARGER.

plate or paper. The opening c must be recessed or have a beading to prevent the negative falling through. It will be seen that, as there is but a slight adjustment of the focus, only one size of enlargement can therefore be made; so that, before constructing such an apparatus, it is necessary to decide what the amount of magnification is to be, and to ascertain the focal length of the lens. Suppose the negative to be quarter plate, and it is desired to enlarge to whole plate; then there will need to be three times the focal length between the lens stop and printing frame, and half this distance between lens stop and negative. The top D may be made to

move to supply the necessary adjustment, or the box A may be in two sections, one fitting over the other, or the lens may be fitted with rack and pinion. A door E in the side of B enables the operator to see the image properly focussed on a sheet of white paper placed in the printing frame. This last slides through the slot F, and is provided with a card or vulcanised fibre shutter in front. The whole of the interior must be blackened.

USE OF DAYLIGHT ENLARGING APPARATUS.

To use the apparatus, proceed as follows:—Fill the printing frame with a

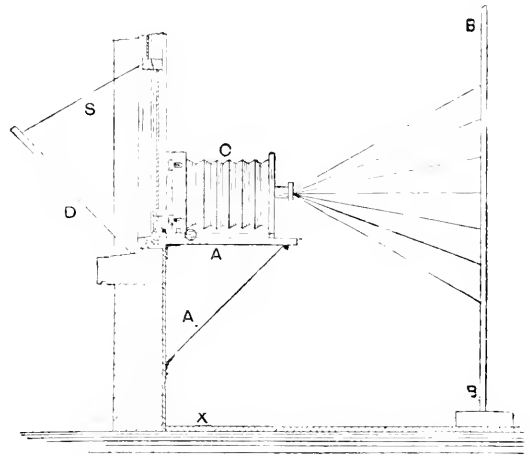

Fig. 422.—DAYLIGHT ENLARGING APPARATUS.

sheet of clean white paper as just described, and place in the position indicated. Insert the negative—film downwards—in the opening c (if a film is being dealt with it should be placed between two clean pieces of glass, which may be held together with gum paper or a rubber band). In any case the side actually bearing the image must be towards the sensitive material, or a reversed picture will result. The door E is now opened, and if necessary covered with a cloth, and the adjustment used until the image appears sharp, when the door may be closed. The frame may then be taken to the dark room, the plain paper replaced by bromide, and the shutter

closed. After inserting this in the camera, cover the opening *c* and remove the shutter. The necessary exposure is given by uncovering the opening *c*. The fore-

by Fig. 423, which is of fixed focus, and the similar but more finished arrangement illustrated by Fig. 424. Fig. 425 shows a highly ingenious design in which the

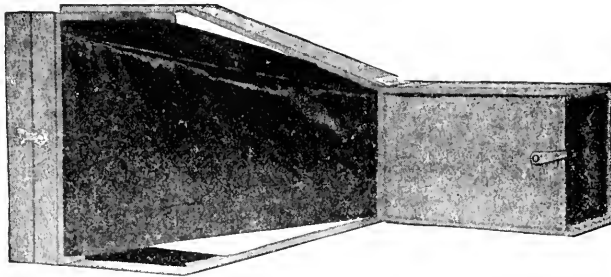

Fig. 423.—SIMPLE FIXED FOCUS ENLARGER.

going deals with a home-made apparatus, but similar enlargers may now be had of almost all dealers. Fig. 422 shows a far better and more usual form of apparatus, but of course more costly and less likely to be found convenient by the majority of

distances between the negative, the lens, and the paper are always proportionally adjusted, so that an enlargement of any size within the compass of the camera can be obtained in correct focus by a simple turn of the screw. In the illustration will

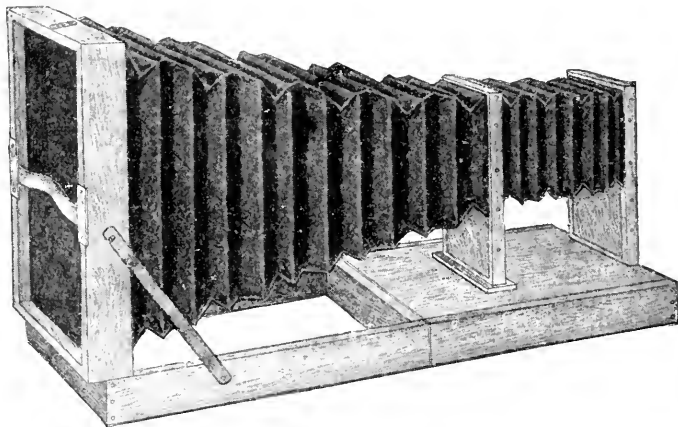

Fig. 424.—FOLDING BELLOWS FIXED FOCUS ENLARGER.

amateurs. In an improved construction, and with certain additions to be described later, it forms the apparatus in use in all professional establishments. Various forms of daylight enlargers are described and illustrated on pp. 39 and 40; in addition to these may be mentioned the simple and inexpensive apparatus shown

be noticed a parabolic reflector, provided for use with incandescent gas if desired. This is detachable when daylight is employed, and is shown separately by Fig. 426. The two gas burners are screened by the side wings of the reflector, and the light can be regulated from the outside by taps provided for the purpose.

MODIFICATIONS OF THE CARRIER, ETC.

The carrier holding the negative may be made to raise and lower, or move from side to side, in order to obtain a more

posing the reflector does not receive an unobstructed view of the sky, it will yet give the field even illumination. Moreover, the opal can be kept cleaner than the painted board. The camera may be

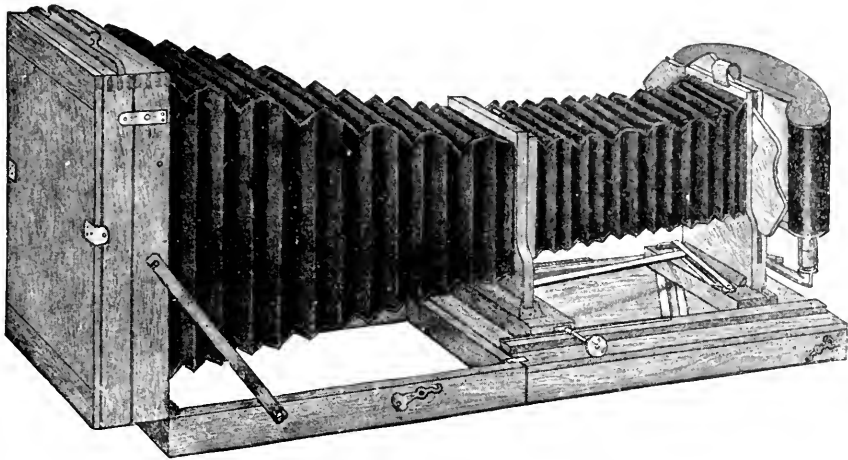

Fig. 425.—ENLARGER, WITH AUTOMATIC FOCUSING ADJUSTMENT.

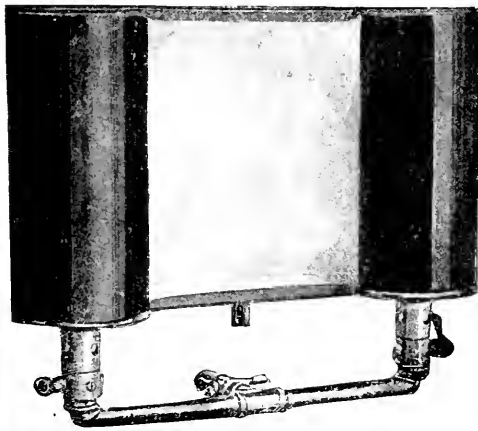

Fig. 426.—PARABOLIC REFLECTOR FOR INCANDESCENT GAS.

of the simplest form, in fact the simpler the better. In some cases it even con-

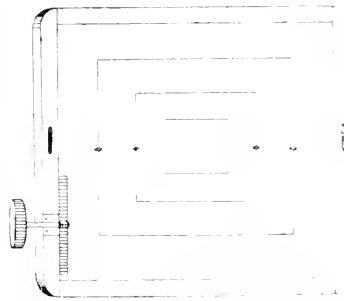

Fig. 427.—ADJUSTABLE NEGATIVE CARRIER.

central image; or in cases where only a portion of the image is to be enlarged. Such an arrangement is shown in Fig. 427. The reflector may consist of a sheet of polished tin reflecting the sky, but it is preferable to use a board painted white or a sheet of opal stoutly framed; the advantage of the opal being that, sup-

sists simply of an arrangement of rods between two frames, over which a cloth is thrown, as shown in Fig. 428. Such an arrangement is easily made, and the expense of a large bellows obviated. This point is of little consequence except in large cameras. With reference to the lens, any good quality lens is suitable, and, generally speaking, one of large aperture is to be preferred. Flatness of

field is an essential qualification, for an image on a flat surface has to be transferred to another flat surface. It is important that the camera should focus either by movement of the front part or

running on the wall, which are gripped by clips attached to a board as shown in Fig. 429. The advantage of such an

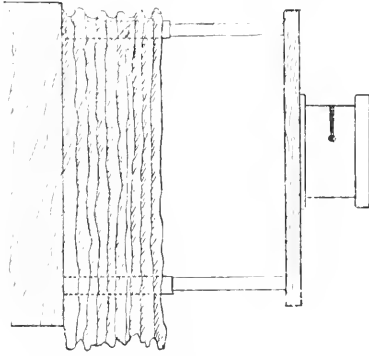

Fig. 428.—CLOTH AND ROD SUBSTITUTE FOR BELLOWS.

by rack and pinion adjustment on the front lens. All cameras which have their adjustment in the back frame are unsuitable, as in focussing the light is let in between the frame and the carrier. Most field cameras are nowadays made on the former principle, but these are not always solid enough for commercial enlarging.

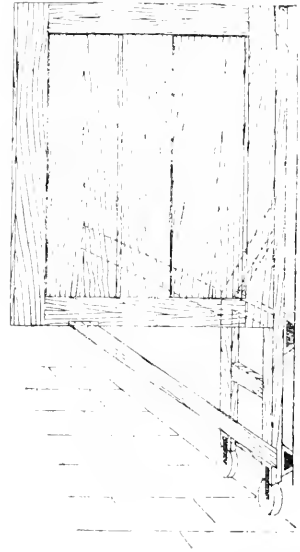

Fig. 429.—EASEL RUNNING ON WALL RAILS.

apparatus is that the guiding rails are out of the way, and there is no fear of

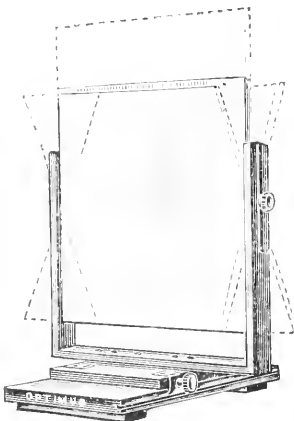

Fig. 430.—EASEL WITH SWING MOVEMENT.

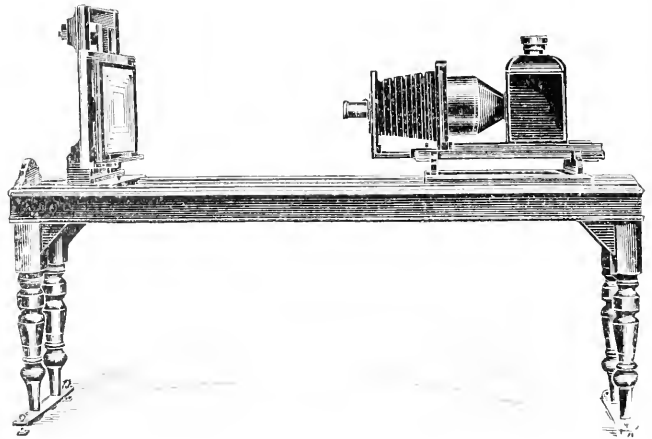

Fig. 431.—THE "SOUTHPORT" ENLARGING TABLE AND EASEL.

THE EASEL.

One modification of that shown in Fig. 422 consists of an arrangement of rails

tripping over them in the dark. Instead of having the adjustable carrier, the easel itself may be made adjustable either for



INTERIOR HENRY VII. CHAPEL, WESTMINSTER ABBEY.

raising or lowering or side movements. A novel and convenient form of easel is that shown in Fig. 430, which, besides a raising and lowering adjustment, is provided with a swing movement, often useful for architectural subjects with dis-

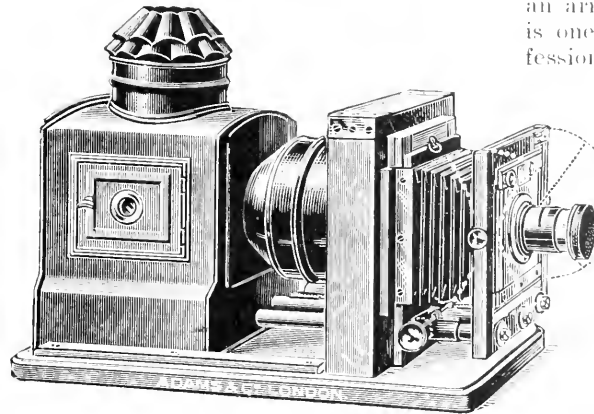

Fig. 432.—CANTILEVER ENLARGING LANTERN, WITH SWING FRONT.

torted lines. The enlarging table and screen shown by Fig. 431 possesses practically every imaginable movement for securing speed and comfort in enlarging, and embodies many ingenious principles.

shown in Fig. 422 remains intact, but over the reflector is suspended a powerful arc lamp enclosed in a white lined hood; this throws parallel rays on the reflector in a similar way to that which occurs with daylight. The disadvantage of such an arrangement is chiefly its cost, but it is one which is largely used among professional workers. Owing to the loss of light by the reflector it is necessary that the illuminant should be exceedingly powerful: this means considerable waste of light, or else long exposures and difficult focussing. Passing from this, one comes to the various methods involving the use of a condenser. With these far less light may be used: even the humble paraffin lamp can be employed to make very successful experiments. Each worker has his own particular fad as to the best illuminant, but either paraffin, incandescent gas, limelight, or the electric arc can be employed. The ordinary coal

gas flame and the incandescent electric arc are unsuitable. Where the source of light is small, such as in the case of limelight or the electric arc, a much sharper image is produced: but as this sharpness

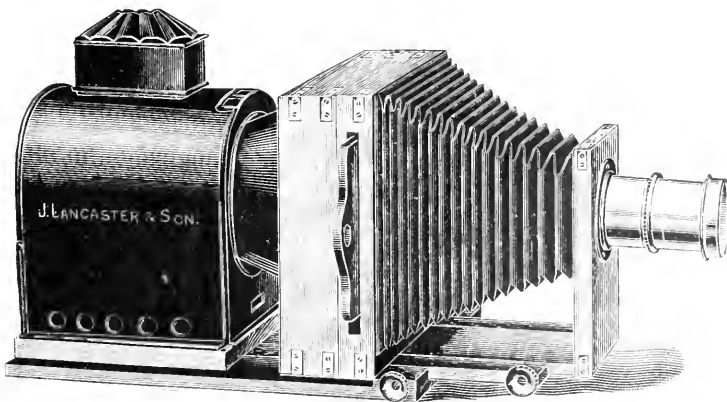

Fig. 433.—THE "EUREKA" ENLARGING LANTERN.

WORKING BY ARTIFICIAL LIGHT.

The best form of apparatus for this work differs only slightly from that described, for in it the construction

usually tends to hardness of outline, it is to be avoided rather than otherwise. The two favourite illuminants are incandescent gas, with which the exposure is short and

the definition crisp with a minimum of hardness, and the paraffin lamp, with which softer outlines are produced, but which has the great disadvantage of excessive heat and a disagreeable odour. The dangers of injury are, of course, greater in the case of the incandescent gas flame owing to the fragile nature of the mantle. The apparatus shown in Fig. 432 is one of the most popular on the market. It is designed on the cantilever principle, and consists of an oil or gas illuminant adjustable to the condenser, in

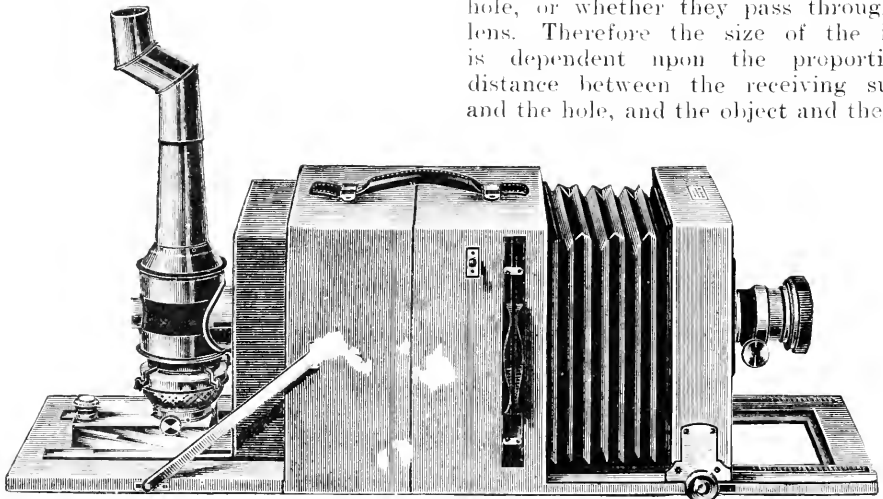

Fig. 434.—PORTABLE LANTERN FOR OIL.

front of which is a framework carrying the negative, which slides in on a carriage. The bellows is racked in and out by means of brass rods passing into tightly fitting tubes. A swing front is provided, which is useful for correcting distortion in the negative. Another excellent lantern, obtainable for use with electricity, limelight, incandescent gas, acetylene, or oil, is shown by Fig. 433. Fig. 434 illustrates a convenient and portable form for use with oil; the lamp, as will be seen, packs away inside.

PRINCIPLE OF ENLARGING WITH A LANTERN

Before going further into details it will be well to consider the principle of en-

larging with the lantern. The phenomenon of producing an image greater in dimension than the object is not necessarily due to any magnifying power possessed by the lens, but merely to the fact that rays of light travel in straight lines, and that those travelling in converging directions will cross and spread out again: and therefore the longer the distance over which they have to travel the more they will have spread out, and consequently the larger the image produced. These remarks apply equally whether the rays pass through a small hole, or whether they pass through the lens. Therefore the size of the image is dependent upon the proportionate distance between the receiving surface and the hole, and the object and the hole,

or the lens, supposing there to be one. These distances bear a definite relationship to each other, and are referred to in the case of the lens as conjugate foci.

CALCULATION OF CONJUGATE FOCI.

Having discovered that there exists a regular and definite relationship between these two distances, it was easy to formulate a rule by which they might be calculated with sufficient accuracy beforehand to avoid waste of time. In fact, in a number of ways, a knowledge of this rule will prove of immense service. The distance from the front lens to the easel is called the posterior conjugate, and the distance from the lens to the negative the anterior conjugate.

In calculations the two distances are usually referred to as "D" and "d." The length of the two conjugates depends upon the focus of the lens, which may be called "F," and the proportion which the enlarged image bears to the negative, or the ratio, and this may be called "r." To calculate these two distances it is therefore necessary to know the focus of lens and the ratio. The latter is readily found by dividing the longest side of the proposed enlargement by the longest side of the negative. The distances may then be ascertained without the smallest knowledge of mathematics, and may be expressed as follows: $D = F \times (r + 1)$ and $d = D \div r$; or, in other words, the posterior conjugate is equal to the focus of the lens multiplied by the ratio and one added; and the anterior conjugate is

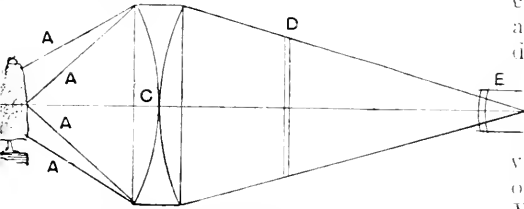

Fig. 435. - OPTICAL CONSTRUCTION OF ENLARGING LANTERN.

equal to the distance from lens to enlargement divided by the ratio. Supposing it is desired to enlarge a quarter plate negative to 12" x 10" with a 5" lens, then substituting values, the sum will be: $5 \times (3 + 1) = 20$ or D; $20 \div 3 = 6\frac{2}{3}$ or d; where F = 5 and r = 3.

SUFFICIENCY AND DISTRIBUTION OF LIGHT.

As the light has to be spread over a large area, it will at once be seen how essential it is that a full quantity of light should be available, otherwise the exposures will be prolonged. Further, it is important that the light should be evenly distributed; an excess of light in any particular spot causing the print to appear undesirably dark in that place. With daylight there is little fear of trouble from either of these defects, but

with artificial light special precautions are imperative. When rays are parallel, as in the case of daylight, or practically parallel, as when using an arc light enclosed in a parabolic reflector, such rays may be used without fear of uneven illumination; but where a bare light is used which is smaller than the negative to be enlarged, unless the rays are condensed by means of a convex lens, or series of lenses, the effect will be very bad. Fig. 435 shows the general principles of an enlarging lantern. The rays A proceed from the burner B, are received and bent inwards by the condenser C, and pass through the negative D to the objective E, where they cross and open out on to the bromide paper. The position of the negative should be at the spot where the light evenly illuminates the corners. The essential features of such an arrangement may now be considered in detail.

THE SOURCE OF LIGHT.

The initial points to consider are (a) convenience, (b) cost, (c) size limit, (d) class of register, (e) class of sensitive material. With regard to (a) this is a matter best decided by the student himself, and dependent upon local circumstances; whilst (b) is so dependent upon special conditions that it need not be discussed. With reference to (c), the largest dimensions to which it is proposed to enlarge exercises some influence upon the choice of light, inasmuch as a powerful illuminant is imperative for enlargements of several diameters; whilst, for smaller sizes, almost any illuminant may be chosen. For it must be remembered that the light intensity falls off very rapidly as the dimensions of the enlargement are increased. For example, an enlargement of four diameters will possess only one-fourth the light intensity of one of two diameters. This shows how greatly the difficulties are multiplied as the size of the enlargement is increased, and how essential it is that perfect negatives with clear shadows should be used, together with a brilliant illuminant. This latter point shows the influence of (d), which depends not only upon the matter just

stated, but also upon the size of the negative. The larger the negative the more chance of uneven illumination, especially when either of the methods of reflecting the light is employed. The weaker the light, the more chance of unevenness and of falling off towards the margins of picture. To sum up, therefore, the larger the negative it is intended to use, the more brilliant and actinic should be the illuminant (*c*). Obviously the same illuminant cannot be used with equal success upon all classes of sensitive material. For example, when enlarging upon bromide paper a different strength of light will be required to that used when making enlarged negatives, on dry plates, or even by the wet collodion process. If, however, a sufficiently strong light is chosen, it can usually be toned down by one or more thicknesses of ground glass or opal, which serves further to produce more even illumination.

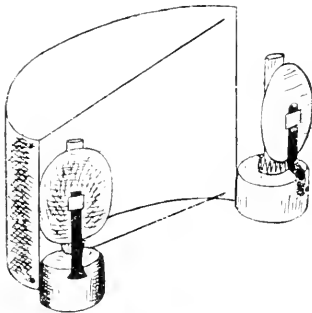

Fig. 436.—ENLARGING WITHOUT A CONDENSER.

ENLARGING WITHOUT A CONDENSER.

Very satisfactory results may be obtained when the negatives are good and do not require dodging, but enlarging by such means is only a makeshift. The best plan is that shown in Fig. 436, where two lamps, A, are used to secure even illumination, and these lamps shine upon a sheet of cardboard, B, bent into circular form and held so by a thread, C. D is the camera. The exposure is of course considerably longer than when a condenser is used, but if the lens works at $f/6$, it will not be very prolonged. Good work

may be done by means of a parabolic reflector constructed for burning magnesium ribbon at one side (see Fig. 437). The magnesium is ignited by means of a match through the hole shown.

THE CONDENSER.

Condensers usually consist of two plano-convex lenses enclosed in a metal rim, as in Fig. 438, the convex surfaces being turned towards each other. These can now be purchased quite cheaply of all photographic dealers. A condenser of $5\frac{1}{2}$ " diameter costs about eighteen shillings, and one of $8\frac{1}{4}$ " about three pounds. As

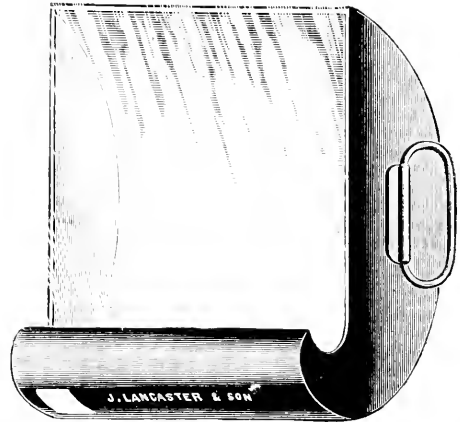

Fig. 437.—PARABOLIC REFLECTOR FOR MAGNESIUM RIBBON.

will be seen by reference to Fig. 435, the object of the condenser is to collect as many rays as possible, and to cause them to converge and come to a point on the front lens. Further, the condenser and negative must be in such relationship to each other that the cone of light formed by the condenser just illuminates the margins of the negatives and no more. The form which the condenser must take to bring about this result depends upon the direction of the rays or the character of the light being used. For example, when the rays are parallel, a simple convex lens will suffice to bring about the desired result, always provided that the focal length of the condenser is equal to the focal length of the lens. When a con-

condenser is used with daylight it is employed merely to shorten the exposure, and it is very rarely indeed, nowadays, that such is necessary. It is better for the condenser to be too long in focus than too short, for, whereas, when the distance between the condenser and the point of the cone of light is too great, this can generally be arranged for; yet, on the other hand, if the cone is formed nearer than the lens may be placed, there is no remedy. This is one of the most important matters concerning condensers, and is usually overlooked. Although it is a matter of comparatively little consequence in the optical lantern, yet, in enlarging, the annoyance of a condenser of too short focus is considerable, for in this work an image has to be produced of a set size. In the case of an ordinary illuminant, however, the rays are not parallel, but divergent, and require more bending to bring them to a point. For this purpose, therefore, a more powerful lens or series of lenses must be employed, hence the reason for the form usually taken by the condenser as explained by Fig. 435.

DIAMETER OF CONDENSER.

The diameter of the condenser is a most important consideration, for, unless the condenser is large enough, the illumination will be hopelessly unequal. The diameter of the condenser must *exceed* the diagonal of the negative it is used with: for example, a $5\frac{1}{2}$ " will cover a quarter-plate only, or an $8\frac{1}{4}$ " a half-plate.

THE REFLECTOR.

It will be noted, further, that unless a reflector is used a large quantity of light must be lost: hence, it is usual to place a reflector having a concave surface behind the light. In most lanterns the position of this reflector is fixed, but such should not be the case. Every alteration in the position of the objective or front lens means a corresponding alteration in the position of the light; which, in turn, necessitates an alteration in the position of the reflector. For example, if the degree of enlargement is small, the ob-

jective will be farther from the condenser, and the light will need to approach the condenser to obtain even illumination. This is of most importance when the source of light is small, as in the case of arc or limelight. There is one exception to the foregoing remarks concerning the reflector. When a paraffin flame is used, the rays should not be reflected to a focus on the flame, as the excessive heat thus condensed will lead to a poorer light. The reflected rays in this case should just fill one face of the condenser.

DIFFUSERS.

In certain cases (*i.e.*, when the source of light is small) a diffusing screen placed between the light and the condenser is an

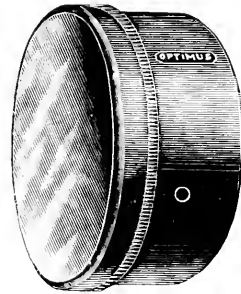

Fig. 438.—ENLARGING CONDENSER.

immense advantage, for example, where the negative has been retouched, or, more especially, where it has been dodged by working on both back and front. Such diffusers may consist of a framed sheet of either opal or ground glass, the latter for preference; as, although it diffuses the light less, it does not cause so much loss. Sometimes it is even sufficient to use a varnished glass which has been rubbed matt with a little powdered resin, or a ground glass rubbed over with oil. Not only are the outlines in the enlargement softer, but the illumination is made more equal at the margins by the use of such screens.

CARRIERS.

The negative holder or "carrier" should preferably slide firmly into position without the aid of spacers (see Fig. 427).

It should also be adjustable horizontally and vertically. Lastly, it should hold the negative tightly in position, that is, not allowing it the slightest movement in the direction of the lens. This, if overlooked, often leads to a fuzzy, indistinct image, particularly if there is the slightest trace of vibration in the enlarging room. In some cases a draught through the apparatus has been known to cause a like result. It must be borne in mind that the movement will be more apparent in the enlargement in direct proportion to the degree of magnification.

THE ENLARGING ROOM.

This must be of sufficient size to move about easily in, whilst permitting the making of enlargements as large as required. A small room usually suffices, but the exact space depends upon the focal length of the lens. A long focus lens of large covering power is quite unnecessary. The room must be fitted with one or more ruby lamps, so that work may proceed comfortably and without fear of accident or breakage. It should preferably be on the ground floor, as there is less likelihood of vibration. In fact, freedom from vibration is a most essential point in either enlarging, copying, or making lantern slides, and when these have to be undertaken near a busy thoroughfare it is best that they should be done in a room situated on the ground floor or in the basement. In the case of copying, the trouble may be to some extent overcome by swinging the camera from the ceiling; but this is not convenient in the case of enlarging. A good solid floor of cement or wood blocks is of benefit. Part of the room should be fitted up for developing, as it is not convenient to take the exposed papers about from one place to another. An enlarging room on the ground floor has one great disadvantage, namely, the difficulty of securing even illumination in daylight. Where the work is done in a quiet neighbourhood, a top room will be found on the whole most satisfactory. The usual dark room may readily be adapted for enlarging if other space is not available.

THE CAP.

In all ordinary circumstances—that is to say, except when using apparatus in which the position of the sensitive material is fixed, as when using an enlarging camera, or with some special forms of easel—it is necessary to be able to see the position of the image when adjusting the sensitive material. A lamp in the room giving a view of the easel front is of no use for the purpose, as the exact position of the image on the paper is what is required. For this purpose a ruby or orange cap must be provided, and is usually supplied with the apparatus. It may be easily extemporised with a piece of coloured gelatine fixed in the lid of a circular cardboard box of sufficient size; this has the advantage that it does not affect definition when placed over the lens. However, no notice need be taken of the blurred effect which results from the interposition of the ruby cap, as this is merely due to the unequal surface of the glass, and as the exposure is not made through it, it is of no consequence.

THE ENLARGING LENS OR OBJECTIVE.

All that is desirable in the lens, in addition to the greatest possible freedom from faults, such as spherical and chromatic aberration, astigmatism and curvature of field, is that it shall work with as large an aperture as possible, and that it shall cover sharply to the corner the negative which is being enlarged. The size of the enlargement has no direct connection with its covering power, but, of course, the greater the enlargement the more any defects the lens possesses will be apparent. Any of the modern flat field lenses and anastigmats are admirably suited for enlarging. It is of most importance that the lens should work with a large aperture when using artificial light, and as with such light it is seldom possible to use a stop, it will be seen that a lens of good quality and of the portrait class must be used under these conditions. When using a small source of light, the effect of using a stop is often to cut off a portion of the image, and not to

distribute the effect all over the picture, as is usual. If the rays are parallel, as when using daylight, a stop may be used to improve marginal definition. A similar result may be obtained, but to a much lesser degree, by using a diffuser. There is a very common fallacy among beginners that the lens must be one capable of covering an image the size of the enlargement, but although this is true in a sense, it is practically wrong. If the lens is able to produce an image *the size of the negative* sharply to the corners, that is sufficient, and the same lens may therefore be used for making enlargements of any reasonable dimensions from the same negative.

THE CHOICE OF NEGATIVE.

The essential qualities in a negative for enlarging are, (a) extreme sharpness of definition, not merely in the centre of the image, but all over the picture; (b) clearness of shadows; (c) proportionate gradation in both high lights and shadows; (d) freedom as far as possible from all mechanical defects such as pinholes, spots, etc., which are, of course, magnified and rendered more apparent in direct proportion to the degree of enlargement. To secure quality (a) it is advisable to use a somewhat smaller stop than is customary for general work, also to exercise especial care in focussing. When it is impossible to use a small stop, as in groups or certain other work necessitating instantaneous exposures, the composition should be as near as possible in the same plane. It frequently happens, however, that such arrangement is impracticable, and then recourse may sometimes be had to swinging the back so as to accommodate the focus; the angle at which it is swung must be such that the line passes through the focus of the principal objects. This position may be ascertained beforehand by calculation or by trial. If, however, the background or the subject contains any vertical parallel lines, the rendering will be false, and it then becomes a matter of compromise. To secure quality (b) a slight extra trace of potassium bromide may be added to the developer, and

development should not be allowed to proceed quite so far. Much, however, will depend upon the brand of plate, some makes allowing considerably more development than others, while preserving the clearness of the shadows. The addition of the potassium bromide will have the further advantage of securing a better gradation in the high lights, if development does not proceed so far as to clog them and produce too much contrast. A dense deposit in the high lights will lead to large bald patches in the picture, which can only be dealt with with the greatest difficulty. It is useless having gradations in the high lights which are out of proportion to the shadows. As pointed out in the section on Exposure, all attempts to force out detail in one portion cannot but result in a weakening of all the other gradations in the picture. Resort must then be had to shading parts in the enlargement, which, though feasible, becomes at times very complicated. In all cases as little shading and dodging as possible is advisable, as, although it is surprising what may be done by a worker of skill and experience, yet it is usually attended with considerable risk of failure. Negatives which have been retouched to any great extent also need special treatment.

ORDINARY METHOD OF PROCEDURE.

The enlarging apparatus set up, the first requirement will be to see that the circle thrown by the lens is evenly illuminated, and this should be done before inserting the negative. If the disc shows a dark line across it, this will indicate either that the reflector is too small or that it is at a wrong angle, and it must be altered accordingly. If artificial light is used, it must be seen that the illuminant is accurately centred and in a line with the condenser and lens. The arrangement of the enlarging lantern and easel, as in actual work, are illustrated by Fig. 139.

FOCUSING.

This is an operation which, generally speaking, calls for a certain amount of skill and considerable care, owing to the

dim nature of the image. It will be found easier to focus by moving the position of the lens if provided with a rack and pinion movement. If the position of the easel is altered, the change will be so

until considerable experience has been gained, to make several trial exposures on small pieces of bromide paper, before pinning up the actual enlargement. The exposure should be such as will give a

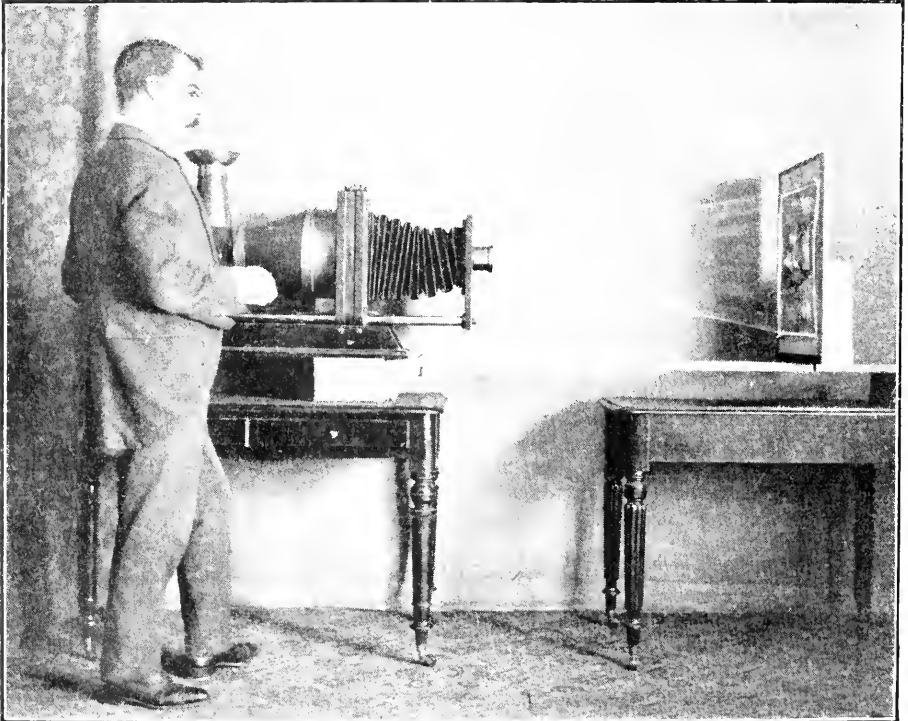

Fig. 439—ENLARGING BY ARTIFICIAL LIGHT.

gradual as to be very confusing. When, however, as in that shown by Fig. 430, the easel itself is provided with a screw adjustment, it is a great advantage to be able to examine the image closely while finally focussing.

THE EXPOSURE.

The exposures being all "time" they may be made by removing the ruby cap before referred to. Care must be taken that the cap does not fit too tightly, or there will be danger of vibration. In any case it is well, after removing the cap, to allow it to remain in front of the lens for an instant so that any possible vibration may subside. It is advisable, at any rate

bright, vigorous result, with perfect detail in the lights and freedom from hardness and chalkiness.

DODGING.

A negative which is to be enlarged should always have a contact print taken from it first of all, as this will afford an opportunity of judging its values better. It will be seen from this whether any portions appear too dark, and if so, these must be shaded up when making the enlargement. To do this, cut a piece of thin card, approximately the same shape as the portion to be shaded, and about two-thirds the size. This must be held between the lens and the easel. It some-

times happens that there are several of these places, and when the size of the enlargement permits, it is best to use separate pieces, each of which may be supported in clamps (see Fig. 440). Where the place comes by itself near the centre it may be attached to a piece of wire as shown. These cards must be moved during the exposure to prevent a hard outline, but this may readily be accomplished by placing the clamps upon a board, which may be gently raised and lowered during the exposure. The shading, of course, only takes place during part of the exposure, and the length of time can only be found by experiment.

VIGNETTING.

This is a similar and easier operation. A card is cut of the desired shape (see section on Preparing the Negative), and is made sufficiently large to prevent the light creeping round the outsides and causing fog. This is held between the easel and lens and moved during exposure. When there are very thin portions near the margins of the picture which it is not desirable to show, special precautions must be taken to block them out, such as placing cotton wool over them, or in some cases paper.

INTRODUCTION OF SKIES.

The advantages of a pleasing sky are obvious, while the disadvantages of a blank sky need not be pointed out. The first thing is to decide as to the cloud effect desired, but if the picture has already been printed in the small size—as it should have been—the matter is easy. If the small print should have been done in bromide, a knowledge of the proportionate exposure will have been gained also. This is essential, as upon it depends whether the clouds are printed to the right depth. The general fault in this work is that the clouds are printed too darkly and heavily. The usual method of procedure is as follows: The enlargement of the landscape or seascape is exposed in the usual manner, except that the sky is shaded with a card suitably cut so as

to give a clean sky to work upon. If, however, the sky includes ships' masts, or similar things, they must of course not be covered, but the sky blocked out on the negative. In any case, even when the sky portion is sufficiently dense, care must be taken that there are no pinholes. The sensitive paper is now taken down—its position on the easel and the portion printed having been carefully marked—and some indication made as to which is the top, so that it may be put up again in correct position. Sometimes it is more convenient, instead of removing the

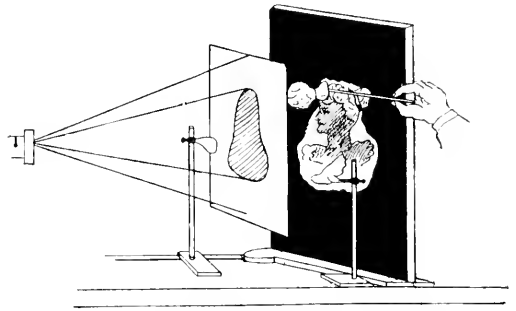

Fig. 440.—ARRANGEMENT FOR DODGING ENLARGEMENT.

bromide paper, to cover it with a sheet of opaque white paper, upon which the new image should be focussed. The cloud negative is now inserted in the carrier in place of the landscape negative. This need not be the same size, although, of course, it simplifies matters if it is, as no readjustment of the apparatus is necessary. In any case an image of the proper size must be projected, but need not be quite sharp; as, if so, the mechanical defects of the cloud negative will be made apparent. The bromide paper is then replaced in proper position, which may be seen by the light admitted through the ruby or orange cap. Where the light is dim it will be found best to mark the position by means of pins. Convenient pins for bromide work are shown by Figs. 441 and 442. They can be purchased of most dealers, or an efficient substitute may be made by inserting small needles in short portions of a penholder.

DEVELOPMENT.

What has been said on this subject in the section on Development Processes of Printing, applies here with equal force.



Fig. 44L.—PIN FOR BROMIDE PAPER.

As, however, enlargements are usually much larger than ordinary bromide prints, it often happens that special means have to be adopted. For general work, wooden dishes with glass bottoms will be found convenient to use. Those workers who



Fig. 442.—GLASS-HEADED PIN FOR BROMIDE.

make a practice of always developing immediately after exposure, to be sure of the result before interfering with the apparatus, will find it the best plan to use. Some workers, however, profess to be so sure of their results that they develop a number together.

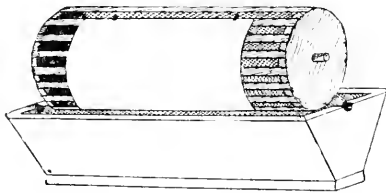

Fig. 443.—SPECIAL DEVELOPING ARRANGEMENT FOR LARGE SIZES.

SPECIAL APPARATUS.

Whichever plan is adopted there will occasionally be sizes which cannot be conveniently manipulated in this way; as, for instance, with panoramic scenes. In such cases an apparatus like that shown in Fig. 443 will be necessary. It consists of a skeleton cylinder formed of two wooden discs and connecting laths as

shown, and the print may be fastened round it with wooden clips. A wooden trough must be provided to hold the developer, and this must have slots cut on either side to take the axle which passes through the cylinder. Where parts do not develop up quickly enough and local treatment seems advisable, the developer may be poured on from a measure, or it may be applied with a sponge or tuft of cotton wool. When developed, it is sprayed with water, and transferred to another trough containing hypo., and then again sprayed. A convenient arrangement for washing these large prints is shown in Fig. 444, and is easily made by any one possessed of ordinary tools and the necessary skill. It consists of a

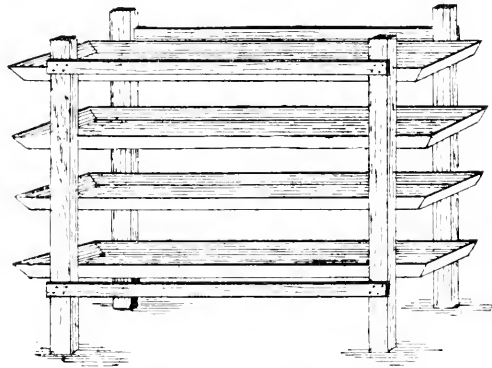

Fig. 444.—FLAT WASHER.

framework supporting several large dishes, in which the prints are allowed to soak singly. After a time each dish is tilted, which empties its contents into the one below. A mechanical washer for enlargements is shown in Fig. 445. It closely resembles the apparatus used for development, but is provided also with a water wheel, which, with a fair pressure of water, keeps the cylinder revolving. Neither apparatus is commercially obtainable.

CUTTING AND MOUNTING.

With small sizes the prints are cut as usual by laying upon a sheet of stout plate glass and covering with another glass of suitable size. This may be a proper cutting glass as obtainable from the

dealers, or it may be an old negative, the film of which has been washed cleanly off for the purpose. In choosing a plate, the greatest care must be taken that the sides are exactly at right angles, or, of course, the prints will be crooked. Generally speaking, however, the plates are cut with extreme accuracy, as great care is taken over this in the factories. It is best not to use too large a knife for cutting, as the cut is less likely to be clean and true; and it should be turned in at a slight angle, so as to get right into the angle made by the glass with the print. The glass must be held firmly in position by the left hand, but it is not necessary to press very heavily. The large sizes are usually framed close, and are therefore generally left uncut and only rough mounted. They can then be

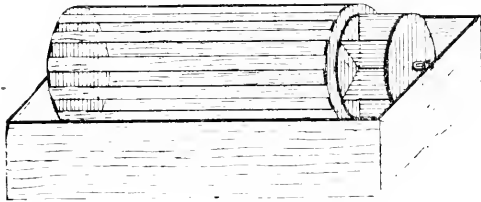

Fig. 445.—ROTARY WASHER.

trimmed down when framing, or, if desired, a cut out mount may be fixed over them. Cut out mounts are dealt with in the chapter on Mounting and Framing Pictures. The only special point to consider with reference to mounting is that concerning very large prints. These are best mounted on a canvas stretcher, as otherwise the pictures become too heavy and clumsy.

ENLARGED NEGATIVES.

These may be made with the apparatus already described, by placing suitable rails across the easel to carry the plate as shown in Fig. 446; the method of procedure in all other respects being precisely similar. Of course, the exposure, being upon a plate instead of a paper, will be proportionately less, and the

material being more sensitive, must be guarded from light with greater care. In using the arrangement above illustrated, it is necessary to focus on a piece of opal glass, which slides into the same groove occupied by the plate. Enlarged negatives are more frequently made through the camera, but this necessitates large apparatus and generally considerable extension of bellows. Negatives may be made larger by expansion of the film; this is described on p. 317.

COPYING.

Copying is merely photographing a picture at close quarters. To make a

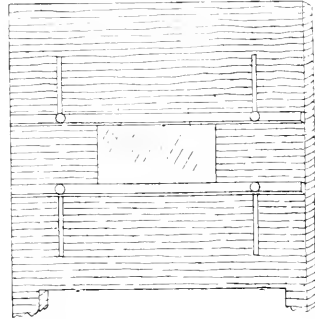

Fig. 446.—RAILS FOR MAKING ENLARGED NEGATIVES.

negative from any picture, the picture is pinned on a board and fixed square and parallel with the camera; the camera is considerably extended, according to the size of the image required and the focal length of the lens. The bellows must open out to at least twice the focus of the lens. A small stop and slow plates should be used, and when the original is weak in contrast a hydroquinone developer is suitable. The shorter the focus of the lens the less extension of camera is required. The amount of enlargement is governed by the sharpness of the original photograph and the texture of the paper of the original and of the required print. About three or four diameters is the usual enlargement; beyond this the grain of the paper becomes so apparent as to kill the delicate shades of the picture. However, the coarse grain can be almost entirely

obviated by copying in sunlight or under glass, and yellowness by using isochromatic plates. With glass the difficulty is to avoid reflection, and no rule can be laid down, so much depending on surroundings. It is generally best to have a strong front light and the sides screened in the manner presently to be described, whilst any bright metal work on the front of the camera should be covered. To get a print under glass, that is, in optical contact with the glass, immerse the two in water, and float the print on to the glass under the surface of the water. Copying is best done by daylight, but it may be successfully done also by electric, magnesium, gas, or lamp light, but in the

COPYING OLD AND FADED PHOTOGRAPHS.

The chief difficulty in photographing a faded print is the obtaining of sufficient contrast. Not only has the image become lighter, but the paper, which ought to be white, has become yellow, and this yellow, showing dark in the print, will, with the faded image, conduce to a flat result. The yellowness of the paper may to some extent be counteracted by placing behind the lens a sheet of pale blue glass, which acts as a light filter and obstructs the passage of the yellow rays. The following treatment has been recommended for strengthening the image. Make up the following solutions: (a) Car-

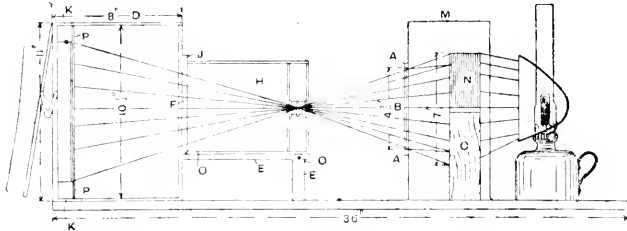

Fig. 447.—ENLARGING BY ARTIFICIAL LIGHT WITHOUT A LANTERN

last two cases pin up the picture, and arrange to have the light during exposure half on one side and half on the other. When a creased, unmounted print cannot be wetted, it may be ironed flat from the back and placed in the frame. Use a camera which focusses by moving its back part. Focussing should not be done as in general work. The most convenient method of copying is to place the camera (preferably a heavy one) on a table, alongside of which has been pinned down a tape measure. At the one end is a vertical copying board, attached by bent irons. In the centre is a board sliding vertically, and held by a thumbscrew, while the printing frame moves horizontally in suitable grooves. Camera and copy must always be thoroughly parallel, except when it is desired to cure some distortion in the original. It is somewhat difficult to secure this exact parallelism, unless the camera, and the easel holding the copy, are run on rails or guides.

bonate of lime 4 parts, chloride of lime 1 part, chloride of gold 4 parts, distilled water 400 parts (this is allowed to stand for twenty-four hours before using, is filtered, and must be kept in the dark); (b) Tungstate of soda 1 part, distilled water 50 parts. For use, take 1 part of *a* and 50 parts of *b*. Well wash the prints and place them for ten minutes in the above solution (in which the prints should assume a purple colour), then transfer the prints to a solution of 25 parts of *b* and 1 part of sodium hyposulphite, which will clean the prints. Slow plates or those specially prepared for photo-mechanical work should be employed, and a strong hydroquinone developer, in order to obtain a dense deposit with clear shadows. If the image is still too thin and weak, it may be intensified with mercury and ammonia. The contrast may be still further increased by using a slow developing paper, such as carbon velox. Strong, vigorous pictures with good gradation

may, with a little skilled handwork, be produced from originals that are almost invisible.

ENLARGING BY ARTIFICIAL LIGHT WITHOUT A LANTERN.

Fig. 417 shows an arrangement for making either enlarged negatives or prints without an enlarging lantern. In the bottom of a lidless box *M* cut an opening $4\frac{1}{2}$ in. by $3\frac{1}{2}$ in. : fit grooves *A A* top and bottom, to carry the negative *B* (the box is standing on end). Make a wooden box *D* of the size and shape indicated, having an opening at *F* a little smaller than the hand camera *H*, and with a close-fitting fillet run round it on the outer side at *J*, forming a recess, into which the back of the camera fits, and is supported on the bracket *E*. The bracket is either detachable or hinged at *o o*. At the rear of the box is fastened another fillet *P*, at exactly 13 in. from the lens stops. Cut a slot right down one side rather greater in width than the thickness of a whole-plate printing frame. The frame should now be built up at the same side flush with the outside of the box, and a further piece screwed on, projecting $\frac{1}{4}$ in. each way beyond the opening, and fitting close to exclude light. Insert the frame, facing the lens, and screw another fillet behind it, so that it just runs easily between them. The frame is assumed to measure $10\frac{1}{2}$ in. by $8\frac{1}{2}$ in. Cut from a block of wood *C* a recess to form a bed for the condenser *X*, the centre of which must be exactly opposite the centre of the negative, the lens, and the printing frame. A lid may be hinged to *D*. The camera and other loose parts may then be stored inside. Now construct a board 36 in. by 8 in., hinged in the centre. Put two screws in the extreme end; these, by engaging with holes in *D*, ensure its being always in the same place. Now place the other parts roughly in position. Fix, with drawing-pins at the corners, the sheet of ground glass, rough side outwards, in the printing frame, and insert it in *D*. Having put the negative *B* in position, focus very accurately by moving the box to and fro. The condenser and light are next manipulated until the corners of the negative are illu-

minated and an evenly lighted screen is obtained. Then screw the block in position in *M*, and fit the points for the other parts as before. Instead of using a condenser, a piece of magnesium wire may be burnt behind the negative (if the negative is small), the light being waved about so that the negative may be evenly illuminated. In this case a sheet of ground glass should be placed between the light and negative. To use the apparatus it will be merely necessary to insert the negative, then place in the printing frame a sheet of clear glass, free from bubbles or scratches, and of the same thickness as the ground glass mentioned above. Place upon this, face downwards or outwards, a sheet of bromide paper, and, having turned the light down very low, insert through *K*. If preferred, a sheet of cardboard, which can be slid out after placing the frame in position, may be made to run in front of the printing frame. The above dimensions are worked out on the assumption that a 5-in. focus lens is used.

ENLARGING BY STRIPPING THE FILM.

Negative films may themselves be actually enlarged or expanded without apparatus. The films are stripped with "Cresco Fylma," though hydrofluoric acid is preferable, or a solution formed of 1 part hydrochloric acid to 7 parts water may be used, before or soon after the negative dries; the latter, however, is not recommended. Hydrofluoric acid is used 1 part in 30, and previous to dilution must be kept in a rubber flask. Place the negative to soak in this, and, after a few minutes, just touch the edge of the film with the ball of the finger, when it will begin to frill badly, and with a little coaxing it will soon roll back smoothly off the glass. When right off, remove the glass, pour off the solution very gently, fill up with water, and allow to soak. Now gently touch the film with the tips of the fingers till it commences to turn over the right way up to avoid a reversed image. The dish must be rather more than twice the size of the original negative. After (say) half an hour's soaking the glass may be cautiously introduced into

the water under the film, which is carefully slid on to its surface under the water. It is then brought gently out in contact with the glass, but without air bubbles. Fill the dish with water gently. Hard negatives are the best to treat thus; soft ones require intensifying afterwards.

ENLARGED NEGATIVES BY THE WET COLLODION PROCESS.

The most satisfactory method, however, of producing a big negative when a carbon enlargement is to be made (and the method employed by all professional workers) is as follows: From the small negative a carbon print is first made on special transparency tissue, squeegeed down to a sheet of glass coated with insoluble gelatine and developed as usual. The glass is prepared by coating it with a 10 per cent. solution of gelatine, immersing in a 3 per cent. solution of bichromate of potash, and exposing to the light. The carbon process gives excellent transparencies capable of rendering the finest detail. The transparency is enlarged in the usual way, except that, if made by the single transfer process, the glass side of the transparency must face the enlarging surface, on to a wet collodion plate made as under: Procure or make (see p. 74) 10 oz. of pure iodised collodion, 2 oz. nitrate of silver, 1 oz. of ferrous sulphate, 2 oz. acetic acid, and 4 oz. alcohol. A new glass plate of the size of the required negative must be thoroughly cleaned by rubbing with alcohol, and then coating with collodion as in varnishing a negative. Directly the collodion has set, the plate may be lowered into the silver bath, which should consist of 25 gr. of silver nitrate to each 1 oz. of distilled water. If the dish containing the bath is flat and level, 25 oz. of solution can be made to suffice for a 20-in. by 15-in. plate. After exposure (care being taken to guard the wet film from dust and to keep the drained corner at the lower level throughout), the still wet plate is flowed over with the developer until the image is well out, when the plate is immersed in a fixing bath of hypo. The developer consists of ferrous sulphate 40 gr., acetic acid 20 minims, to

each ounce of distilled water, with sufficient alcohol to make it flow easily. Considerable practice is necessary before plates of this size can be worked successfully. The development of a 20-in. by 15-in. plate is best carried out in a dish, instead of holding the plate in the hand as in small work. Porcelain dishes larger than the largest plates likely to be used must be provided, and the one containing the silver bath must be retained for that especial purpose. Collodion film, unlike gelatine, is extremely tender, and will not bear touching; even a strong flow of water is sufficient to disturb it. It is advisable, though not absolutely necessary, before collodionising, to coat the plate with the white of one egg, 4 drops of ammonia, and 1 qt. of water mixed well and filtered.

COPYING PENCIL DRAWINGS, ETC.

In copying such subjects as pencil drawings, it is most essential that a process plate should be used, unless the drawing is very boldly done. In any case the plate must be a slow one, and the exposure must not be too long. Such work has usually to be done in large quantities, and if a copying board is used as just described, and a small stop, it will not be necessary to focus each time if the pictures have all to be copied to one ratio. The position of the copy on the board must be accurately fixed, so that each succeeding one may be put up centrally without fear of error.

COPYING ONE PERSON FROM GROUP.

It often happens that a single figure has to be copied from a group, where the other figures are not required to show. This necessitates the blocking out of the surroundings, which may be done either upon the negative when made, or upon the original. If the former method is decided upon, this will be found explained in the section on Preparing the Negative for Printing; whilst, if the latter is adopted, one of two methods may be used. A very usual plan is to paint over the print with opaque colour before photographing. This has two serious disadvantages: first, in washing it off it is very possible that the retouching done on the print will be

washed off also; secondly, being on the same plane as the image itself, it is photographed sharply, and gives a very unpleasant appearance. A far better method, although one very little practised, is that of copying the print under glass, and applying the colour to the outside of the glass. This not only gets rid of the excessive sharpness, but also prevents a hard line round the figure. Sometimes it is convenient to do this with a No. 1 retouching pencil, having previously given the glass a good coating of medium. Generally, however, it is best to use Chinese white, to which may be added sufficient of any other colour to match

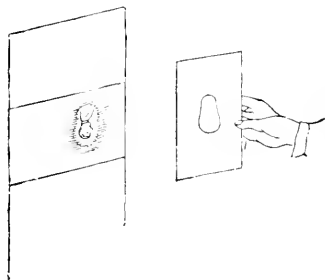

Fig. 448.—METHOD OF MASKING FOR COMBINED PORTRAITS.

the print if desired, but this is not always necessary. In skilled hands it is even possible to introduce new backgrounds in this way. The background is painted out white on the print, and then the new background is sketched in on the glass. The advantage of this is, that the body colour below is not disturbed in putting in the detail.

COMBINING PORTRAITS.

It is sometimes required to produce two copies, say the heads only of two persons, on the same negative. This must be done by vignetting. The paper must be covered with a mask, except a portion somewhat larger than the portion the vignette is to occupy. The one head is exposed, and the mask is now moved so as to bring the next portion into position. On development the heads will appear to have all been taken together. Great care must be used that the ex-

posures are in harmony, that is, that both are in correct proportion to the negatives and to each other. The method of masking will be made clearer by reference to Fig. 448.

LANTERN SLIDES.

Lantern slides may be made by a great variety of processes and methods, in fact, practically all the printing processes have at some time or other been employed for the purpose. Those of practical interest, however, are not very numerous, and may be divided as follows:—*Methods:* (a) Contact. (b) Reduction. *Processes:* (a) Gelatino-Bromide, (b) Carbon, (c) Gelatino-Chloride,

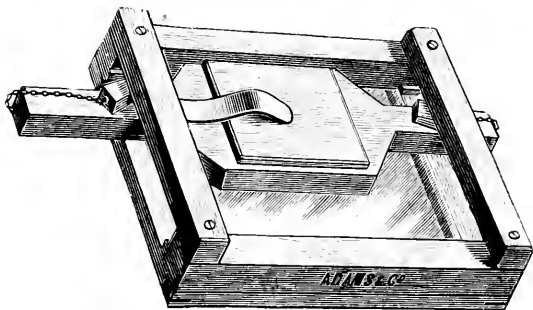

Fig. 449.—LANTERN SLIDE PRINTING FRAME.

(d) Collodio-Bromide. By "contact" is meant where the plate is exposed behind the negative, as in making an ordinary print, the result being an image of the same size. By "reduction" is meant copying through the camera. Under the head of Gelatino-Bromide come the ordinary lantern plates in general use, upon which, probably, nine-tenths of modern lantern slides are made.

MAKING SLIDES BY CONTACT.

This method is extremely simple, and is very similar to the process of making a bromide print or transparency. Its only difference lies in the great necessity for the absolute cleanliness and general perfection of the picture, as, seeing that it is to be magnified many times, any defects it possesses will be made very apparent. The negative used must be one capable of giving a satisfactory result, and be perfectly free from dust, pinholes, and

scratches. A lantern slide printing frame (Fig. 449) will be needed, and the negative

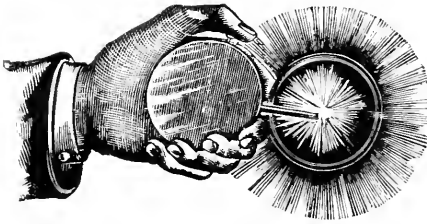

Fig. 450.—POCKET LAMP FOR MAGNESIUM RIBBON.

as the subject is fully dealt with elsewhere. The developing slide is rinsed and fixed, preferably using an upright bath, and well washed, the greatest care being taken to avoid abrasions of the film. It is then stood up to dry in a good current of air, protected from dust, and when dry may be bound up into the form so well known. For this purpose the first requirement will be some masks, consisting of opaque black paper provided with suitable openings.

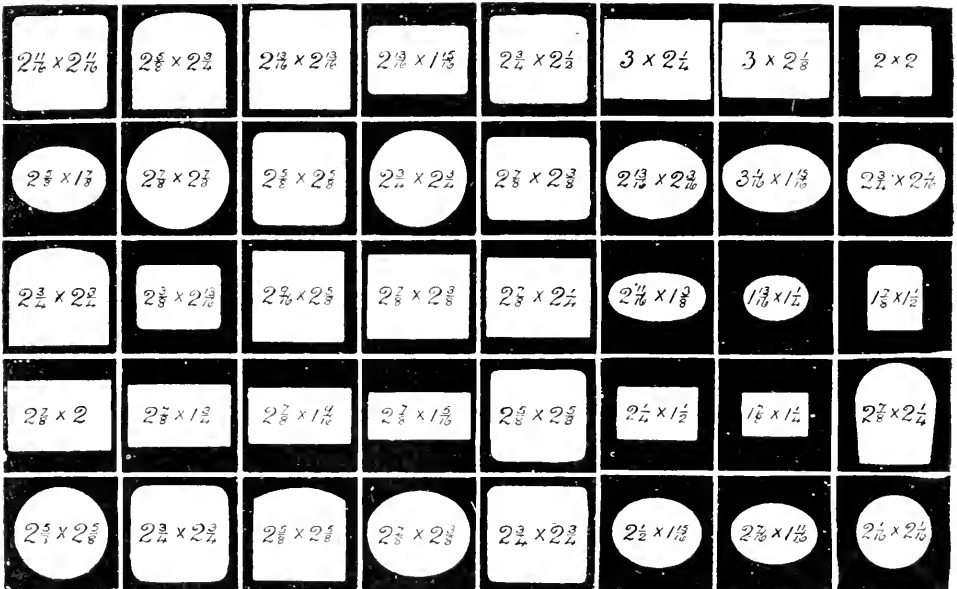

Fig. 451.—LANTERN SLIDE MASKS.

is then adjusted over the opening to show the portion required. This at once indicates the drawback of the method, for, if the negative is larger than quarter plate, only a small portion of it can be shown. The plate is now inserted in the dark room, and the exposure made in the same way as for bromide printing, that is to say, with a gas flame for ordinary work, and magnesium ribbon when producing tones. A convenient pocket arrangement for holding a coil of magnesium ribbon, and burning short lengths as desired, is shown by Fig. 450. Regarding development, nothing need be said in this chapter,

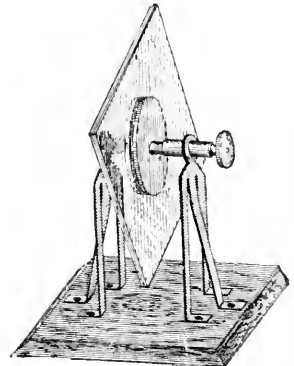

Fig. 452.—BINDING VICE OR CLAMP.



OUTDOOR FIGURE STUDY.

LANTERN MASKS.

These can be purchased at any dealer's in boxes costing about a shilling, and containing an assortment of different shapes and sizes (see Fig. 451). It must be admitted that the choice is very often far too limited for artistic work. Some workers may therefore prefer to cut their own, using for the purpose black needle paper obtainable from any large stationer's. It will, however, be better to use one of the

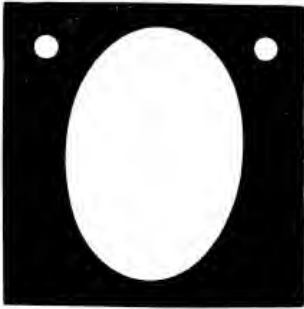

Fig. 453.—METHOD OF PLACING SPOTS.

stock sizes than to risk a jagged border. They will not be very difficult to cut by anyone familiar with the ordinary circular or oval trimmer. A makeshift cutter may be made by attaching a length of watch spring to a block of hard wood. The paper is then stamped out on a sheet of lead. A variety of shapes may be made up by using strips of the ordinary binding. Having chosen one which is suitable, and which leaves visible that portion of the picture which is required and no more, lay it in position on the plate, and on this place a cover glass which has been carefully cleaned. These cover glasses may be purchased, or may be cut by the worker, but the former is the better plan. Old negative glass is unsuitable, as it is too thick.

BINDING.

The two glasses are now taken up and held in the hand, or better still, placed in a holder (see Fig. 452) and bound together with black paper, which may be purchased ready gummed in narrow

lengths known as binding strips. It can be procured cut into small pieces, each equal to one side of the slide, or in long strips covering the whole. It is a matter of fancy which is used. Moisten the strip well, and placing one end on the extreme corner of one side, lay down all round, leaving an equal margin on each side. The lantern slide clamp (Fig. 452) grips the glasses firmly by a turn of the screw. The clamp may be fixed against a support so that the glasses rest on the table, or it may be used as shown. The latter is perhaps the best. The binding being placed in position along one side, snip the margin on either side opposite the corner,

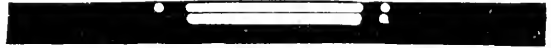

Fig. 454.—SPOT BINDING STRIP.

and press well into contact with the glass, using a soft rag for the purpose. Some workers prefer to cut a V-shaped piece out at each corner on either side. It is perhaps a matter of fancy, but the former seems simpler, and looks quite as neat if carefully done. When one side is fixed, which should be done as rapidly as possible, the slide is turned round and the next side fixed in the same way. A little practice is all that is required, and it will be found very simple. A sharp grip of the binding at the extreme edge causes it to bend smartly into shape and fit neatly. When all four sides are done, the glasses on either side should be carefully cleaned with a rag and a little warm water, and the slide may then be considered finished. It is customary, however, for convenience in rapidly identifying the correct side of the slide, to place two white spots, one on either side of the mask, at the top of the picture as shown in Fig. 453. These indicate the top, and the side which must be placed towards the screen. It is not always, however, that such spots may be used, and then the "spot binding strips" are useful, as they occupy less space (see Fig. 454). For those workers who do not care for the trouble of binding up the slide in the manner described, there is a special form of binder known as

"Unified." It is only necessary to lay the glasses down and fold the sides over. Naturally, these are a little more expensive. A somewhat similar affair is the "combination cover glass and binder" (see Fig. 455). These are supplied spotted and with title line. They can also be obtained tinted.

TITLING.

Most slides require at least a distinguishing title, and this may be put on the black mask with white ink, as it will then be kept quite clean by the cover glass. A simple method of making this is to add to a little gum water sufficient Chinese white or sulphate of barium, and

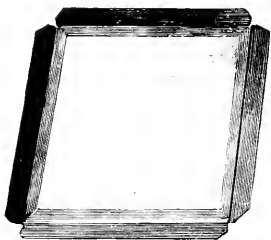

Fig. 455.—COMBINATION COVER GLASS AND BINDER.

mix thoroughly. The ink may be used with a pen as usual.

MAKING SLIDES BY REDUCTION.

The method of making lantern slides by reduction presents more difficulties than the process just described, but is tolerably easy to one who has done a little copying. In principle, it is exactly similar to any other form of making reduced copies, the only difference being that one has to work from a transparent original. The apparatus used for making daylight or artificial light enlargements may be used for this purpose, provided, of course, that the various parts permit of the desired extension. The rails shown in Fig. 456 will also be needed. Those who have this fitted up will want nothing further, but for general amateur work the arrangement shown in Fig. 456 will be found to answer well. It consists of a board, which may be fixed

up so as to point to the clear sky, and at one end is fixed the camera as shown. At the other is a lidless box turned on its side, and having in what was the bottom a hole cut, of sufficient size to accommodate the negative. On the reverse side strips are glued to form a rebate for the negative, and on the near side turnbuttons. For artificial light work without a condenser, the exposure may be made by burning magnesium ribbon behind the negative. The ribbon must be kept constantly moving, and the process cannot be recommended. The more rapid plates, such as Gelatino-Bromide or Collodio-Bromide, can alone be effectively used for

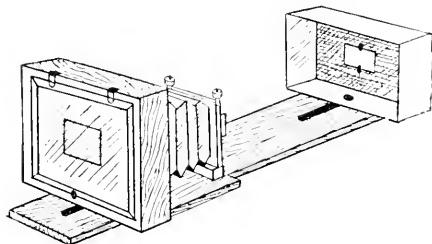

Fig. 456.—APPARATUS FOR MAKING SLIDES BY REDUCTION.

making slides by reduction by artificial light as a rule; but, if daylight is used, most of the processes except carbon can be employed.

PROCESSES AVAILABLE.

Gelatino-Bromide.—This has been fully dealt with in the chapter on Development Processes of Printing. The emulsion is practically the same as used for bromide paper. The same remarks apply to the other processes; the only point worth urging is the strict necessity for freedom from spots, markings, etc. For artistic effects, and when the extra amount of work is not of consequence, the carbon process will be found a most admirable one. Its long range of contrast, beautiful gradation, and the fineness of the grain of the deposit fit it especially for the production of the highest class slides. The slides are made by contact in the same way as a carbon transparency. Where

the negative is larger than the slide, a reduced negative must first be made. The Albumen process is considered by many to be the finest process available for this work. For particulars, see the section on that subject.

DIAGRAMMATIC LANTERN SLIDES.

Extreme cleanliness is necessary in the case of slides of diagrams, where the lines are required to show up as clearly as possible on a perfectly white ground. It is sometimes less trying to the eyes of the spectators, as well as more convenient for experiments which may be in progress—when lecturing upon photography, for example—to have white lines upon a black ground, and for this purpose the negative itself may be used, if of proper size and not too dense. Under the same heading come the various forms of "title" slides, such as are used for making announcements. These may be photographed from printed matter set up for the purpose, but usually a better result is obtained by reduction from a large original. If desired, very elaborate designs may be made up in this way, using letters either drawn or cut from periodicals and pasted on a white board, around which a little sketching may be done. Portions of photographs may be worked into a design surrounded by leaves or flowers, the various parts being combined into a harmonious whole by a few artistic touches with the brush.

DENSITY.

Diagrammatic and similar slides should be allowed as much density as can be obtained without causing the slightest veil upon the background. Generally speaking, the density of a lantern slide will depend upon the illuminant to be used. For example, a slide which is to be shown by the electric arc or limelight may, and in fact should, be considerably denser than one which is to be projected with an oil lantern. The exact density is a matter to be found by experiment. Further particulars upon the subject are given in the chapter on Development.

CLOUDS IN LANTERN SLIDES.

The most effective mode of adding clouds to a lantern slide is by printing them upon a separate glass and binding the two up together. The cloud print then takes the place of the cover glass. This cloud print may be made either by contact or reduction, according to the size of the negative available. The portion occupied by the landscape or seascape should, of course, be bare glass, and to obtain this it must be suitably shaded during exposure. Should it extend too near, or even overlap the landscape, it should be painted out with a strong reducing solution, such as ferricyanide and hypo., or ammonium persulphate. Ready-printed cloud cover glasses can be purchased, and these are also supplied tinted to give sunset effects, etc. Such clouds combine very effectively with a toned slide.

TONED AND COLOURED SLIDES.

These may be produced upon the various slow plates or upon gelatino-bromide plates and toned in the uranium bath, or by one of the various processes given in the chapter on Development Processes of Printing. The colouring of photographic slides will be found dealt with in the section on Methods of Colouring. Gold toning is occasionally adopted for a green blue colour. It gives various tints from pink to blue. The slide is first bleached, and after thorough washing is placed in a 1 in 500 solution of gold chloride until the desired tone is reached. It is not usual to intensify or reduce lantern slides, as, generally speaking, it is much easier and better to make a new slide. They are, however, open to treatment by any of the methods given in the earlier part of the book. Some workers use local reduction considerably, but generally speaking it is preferable to doctor the negative and shade up during portions of the exposure. The following are additional methods which have been suggested for toning slides: *Red (a)*, yellow prussiate of potash 10 grs., water 10 ozs.; *(b)* uranium nitrate 20 grs., sulphocyanide of ammonium 100 grs., citric

acid 20 grs., water 10 ozs. For use, take equal parts of each. *Green*, (a) ferri-

chromate 4 grs., water 10 ozs. When placed in the (a) solution the slide will turn blue; on transferring to the (b) solution it will assume a green colour.

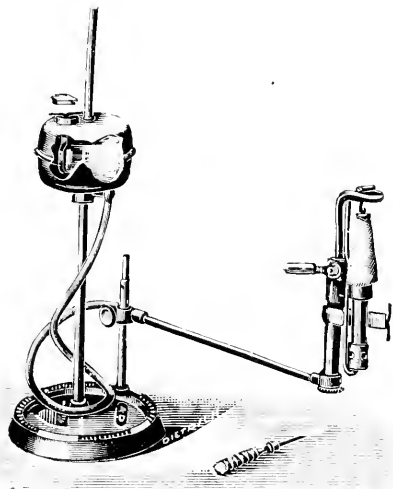

Fig. 457.—THE "SOL" SPIRIT LAMP.

cyanide of potash 5 grs., oxalate of iron 7 grs., water 10 ozs.; (b) potassium

THE "SOL" LAMP.

Before leaving this subject, mention ought not to be withheld of a method of artificial illumination which has lately been viewed with much favour as a useful light for enlarging, copying, lantern slide work, etc. The "Sol" lamp (Fig. 457) is intended for use with spirit, which is contained in the reservoir seen on the left of the illustration, in conjunction with an ordinary incandescent mantle. Provided proper care is taken to keep the various parts of the apparatus unobstructed, and to renew the mantles at reasonable intervals, the lamp will be found extremely useful. In using such a light for copying, it is, of course, necessary to prevent the direct rays of the lamp from reaching the lens.

WORKING-UP PRINTS AND ENLARGEMENTS IN MONOCHROME.

ADVANTAGES AND DISADVANTAGES.

THE principles of retouching have already been explained, and the advantages and disadvantages of such work discussed, in the section on Preparing the Negative for Printing. These arguments, for and against, may be also urged with reference to working up; but certain it is that, on the whole, the advantages far exceed the disadvantages. Except for enlargements of subjects possessing little detail, or such as may be done upon very rough paper and rely upon tone values only, working up is an absolute necessity; whilst in many cases, the print is used merely as a basis for artistic work. Everything will depend upon the skill with which such work is done; but when it is in experienced and artistic hands, it must be admitted that the success depends more on the working up than on the quality of the print. While, of course, recognising the great advantage of securing the best possible print to work upon, it is astonishing how good are the effects which are sometimes produced from the poorest of photographs by good workers. Anyone desirous of learning retouching cannot do better than commence on prints, until a knowledge of the handling of the pencils, etc., has been acquired, together with as much familiarity as possible with photographs in general, particularly with regard to light and shade. It is as well to mention that in pictorial photographs intended for entry in competitive exhibitions no work whatever is allowed on the print itself, with the exception of spotting and removal of de-

fects, although any amount of retouching is considered permissible on the negative.

KNOWLEDGE OF DRAWING.

A knowledge of drawing is not absolutely necessary for this work, but is of immense assistance; especially in the correction and emphasis of outline, and the proper arrangement of the balance of light and shade. There are several clever workers in monochrome who have never learnt drawing, and have very little idea of it; but, at the same time, it is highly probable that had they learnt to draw, their work would have been better and more easily done. A course of drawing is of great value; but a special syllabus is desirable, or too much time will be spent upon work of no practical use. In some art schools, students have to follow a set course, regardless of their occupation. Photographers require such a very general knowledge, that they must economise the time they spend upon any outside subject. What is chiefly required is a course of shading from the cast; but some knowledge of outline drawing must also be acquired. Surprisingly little knowledge of this will suffice, however, for the photographer, who requires principally to learn the values of light and shade, and the massing of tones. It is not intended for one moment to depreciate the value of a thorough knowledge of art; and anyone making a speciality of this work is advised to take a complete course of drawing and painting at an art school. What has been said is merely to encourage those who cannot spare so much time as this plainly necessitates.

SPOTTING.

It is customary, when a pupil enters an establishment with a view to becoming a retoucher, or worker-up, to teach him, first of all, how to "spot." This is a term applied to removing the small blemishes which appear on most prints. In some cases, they may be due to dust, in others to air bubbles, defects in the emulsion, etc., or they may be the result of slight irregularities in retouching the negative, which are not apparent until the print is made. However these may occur, they must be so removed as to leave no trace behind; and this is a comparatively simple matter, when compared to the spotting of negatives. Surprisingly little practice is necessary, if the work is commenced in the right way.

MATERIALS FOR SPOTTING.

The following materials will be required. A few unspotted prints: these should be either albumen, platinotype, or bromide. P.O.P. or carbon should not be used in commencing. Brushes, Nos. 1, 2, and 3; these should be of best sable. They can be obtained of any artists' colourman or from photographic dealers. Colours: Ivory black, crimson lake, ultramarine and sepia will be ample for every kind of print. The latter may be omitted if desired. The ivory black and ultramarine may be in pans, but it is more convenient to use cake colours for the others. With certain shades of carbon, light red and yellow are required. A palette of some description will be wanted, and for this the glazed side of a piece of opal answers as well as anything. Of course, a china palette is better; but these are so frequently broken, that in most workrooms it is more usual to find simply a bit of opal, about quarter-plate size, which, if broken, is easily replaced.

SPOTTING MEDIUM.

As a spotting medium, a little gum arabic, covered with cold water, and allowed to dissolve by gentle heat (by placing it on the hob or before the fire for the purpose) is sufficient.

A very usual medium, at one time, was made with white of egg. An egg was broken open by pulling smartly in two, and the white was collected, taking extreme care not to contaminate it with any portion of the yolk. To this was added one drop of ammonia as a preservative, and the whole well mixed. A little of this, added to the paint in mixing, imparts a decided gloss. The objects of using a medium are twofold: (a) To make the paint flow evenly and adhere properly to the print; (b) to match the surface of the surrounding photograph. Many workers, however, prefer to spot without any medium at all; and for such papers as platinotype and bromide this is certainly the best plan. In the case of albumen, carbon, or gelatine prints, the medium is an advantage, but not imperative. There are numerous spotting mediums in the market, but these do not possess any advantage over those already described.

MIXING THE COLOUR.

For this purpose, a larger brush, which need only be of very rough quality, may be used. Some workers, however, merely wet the tip of the finger and rub it on the paint. Mixing the paint with the finger has its advantages, for the presence of the minutest quantity of grit is at once detected, and a thorough blending is ensured. Suppose a few albumenised prints are to be dealt with. Take a small quantity of black, and rub on the opal, next a little red, and finally a very little blue. Be careful not to get it too blue. To try the colour, take a little up on the brush, and lay it down on white paper, comparing it with the colour of the print. Continue to add one or other of the colours, until the exact tint is matched. If it is too black or blue, add more red. If too red, add more black. The medium is added after the colour has been matched. Only a very small quantity of medium is necessary.

APPLYING THE COLOUR.

Commence by using a No. 2 brush. This should have a good spring, which should be tested for when purchasing it. On pressing the dry point back with the

finger, it should instantly recover its shape. Have a glass of water at hand, and allow the brush, if new, to soak for a moment or so. Lay the print on a board set at an angle, as in Fig. 45s, by supporting it on books or anything similar, and cover the lower portion with a piece of clean white paper. Now take up a little of the colour on the tip of the brush, taking care to draw the latter towards you in doing so, and not to push it away, as this is apt to spoil the point of the brush. The paint should be taken up with a circular motion of the brush, as this draws it nicely to an extremely fine point. Now, with a similar motion of the brush, draw it lightly across the piece of white paper. This will get rid of the excess of moisture, test the exact tint or shade of the colour, and further improve the setting of the point if carefully done. Now touch the spot very lightly, so as to make a dot considerably smaller than the spot which is to be taken out, right in the extreme centre. The accuracy with which this is done will govern the success of the result; therefore, the pupil must practise continuously and patiently to acquire the necessary delicacy of touch and accuracy of aim which enable the worker to place the brush in the exact spot with ease. The brush must not be held vertically to the paper, but should incline at an angle of about 60° , so that the side of the point is used. Having successfully placed a dot right in the centre, add further dots all round this one, of similar depth (*i.e.*, considerably lighter than the surrounding parts if taken individually), until the spot disappears. The great thing is not to attempt to take out the spot in one touch. The more touches that are made, if distributed and not placed one on the other, or even touching each other, the better the effect will be, and the more cleanly and perfectly the spot will be removed. If the touches go one on the other, or even join, they will run together, and the result will be worse than making one big touch. This will be the more noticeable when the paint is wet. The latter should be used as dry as possible, but must not be too dry. In this way, each

spot is taken out, one at a time, or patches are treated as aggregations of spots. In working out long streaks, scratches, and such like, the brush should be drawn right through them from end to end, beginning in the centre and working towards the margins; paying the same attention not to run the spots together or to place the touches upon one another. Where very large spaces have to be dealt with—as, for example, where a piece has to be taken off the shoulder, if one shoulder is too high, or a piece out of the waist where this looks too large—it is best first of all to lay a wash right over the place, of nearly the right depth, only a little lighter, and then to stipple it until the exact tint is obtained. Stippling is

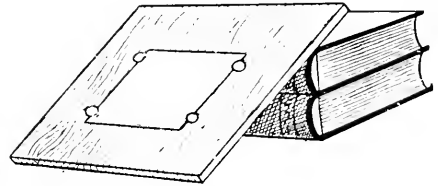

Fig. 45s.—METHOD OF SUPPORTING PRINT FOR SPOTTING.

of course understood to mean making single dots with the point of the brush. The only difference between the spotting of albumen and P.O.P. prints is that of surface. A medium in the latter case is almost a necessity, and care must be taken that the colour is not too wet. Do not moisten the brush in the mouth.

SPECIAL TREATMENT OF ENLARGEMENTS.

Except that they admit of a broader, freer style, and that more work may be put upon them in accordance with their size, there is no special treatment for enlargements; so that the same remarks apply to large and small work, although the work itself must vary in fineness of touch. They may be done in colours, as explained in the section on "Colouring Photographs," or in monochrome, as about to be described. In some establishments, small prints are worked comparatively little, since it is considered that, as they are direct prints

from negatives, nearly all the necessary work can be done on the negative, as instructed in the section on Preparing the Negative for Printing. A considerable amount of work is, however, put upon such pictures by high-class firms, but so skilfully that it cannot be detected. For working up in monochrome, some additional material will be required. Enlargements may be finished in three different

IMPROVEMENTS TO MODELLING.

In doing this, extreme care must be taken to preserve the modelling of the face, as any unintentional alteration to that will be liable to affect the likeness seriously. Certain alterations are, however, quite allowable if skilfully done, but this is just where individual artistic taste is of so much value; since, if overdone, these alterations are very bad. A frowning expression may be considerably softened, a double chin may be toned down, a broad nose may be thinned, and a thin face may be fattened; all without serious loss of likeness, if skilfully performed. The great thing is so to arrange the parts which have been improved, flattered, or whatever it is preferred to call it, that they are not brought obtrusively forward, but remain in shadow, or at least in such an arrangement of contrast that they do not attract attention. In fact, merely by this means alone—namely, softening the contrast—much may be done to apparently flatter a face, without really making any alteration of its form. It must be understood from the outset, therefore, that the art of working up is the same as in portrait painting; namely, to bring into prominence all those parts or features which are good, and to keep obscured those which are less pleasing. This can only be done by contrast. For example, if the subject has a big, misshapen nose, the light upon it must be kept subdued, it must be toned down if necessary, and its outline rendered soft and indistinct; while there must be no deep and firm lines on the shadow side to emphasise its form. Again, supposing the eyes are staring, and inclined to squint, the light may be toned down, and the outline of the iris of the shadowed eye made less distinct. This will, of course, make it less easy to compare the two eyes. A large and badly shaped mouth should have its outline softened. If the eyes are expressionless they may be brightened, by increasing the light in the corner of the eye, and by sharpening the outline of pupil and iris. This must not be done with a streak round it, but by a series of very fine lines taking the direction shown



Fig. 459.—METHOD OF WORKING-UP THE EYES.
(CONSIDERABLY ENLARGED.)

ways: (a) with the brush and water colour; (b) with crayons and stumps; (c) with the Aerograph or air "brush."

WORKING WITH THE BRUSH.

For working with the brush, the few materials already mentioned will suffice. First the print should be spotted roughly, as before described. The face should then be carefully stippled to remove any unevenness and impart to the skin, if desirable, a pleasing soft grain. This is only to be effected by making all the touches of the same shape, and of about the same depth, so as to match properly with other touches.

in Fig. 459. The pupil of the eye should be put on as a dark wash. When dealing with the light in the eye it should be borne in mind that there is a reflected light on the opposite side of the iris, which must be in harmony with it. The nose may, of course, be brought into prominence slightly, where its shape is exceedingly good, by improving the definition of its outline. The chief aim in dealing with forehead and cheeks must be to impart roundness, while preserving the modelling.

A SUITABLE SUBJECT.

For early work, a head of about 6 in. or 8 in. diameter will be the most suitable. This should be smoothed and modelled in short lines about $\frac{1}{2}$ in. long running at an acute angle over the muscles. The lines need not be of any particular length, but may be blended one in the other, and joined on so as to impart a pleasing grain. Keep viewing the picture from different distances. A head of this size ought never to be worked nearer than 2 ft.

LIGHTING.

The picture should be supported on an easel, and the artist should sit as shown in Fig. 460, with the light falling in the direction of the arrow. It makes much more difference than the novice will probably realise, from what direction the light falls on the picture. If the light strikes the picture at the wrong angle when working-up, the result will be that, when the picture comes to be viewed in other lights, it will have a terribly rough appearance, and be covered apparently with all sorts of unmeaning streaks and marks. Strictly speaking, an enlargement ought always to be looked at in exactly the same light in which it was painted; but in commercial work it would be exceedingly difficult to arrange that. As a general rule, however, the picture is worked as shown in the illustration, with the light coming over the left shoulder. The exact lighting one needs to get is that which does not show up the grain of the paper too much, and is therefore fairly full. It can soon be ascertained if the print is being worked

up in the proper light, by doing a little and taking it into another room to look at. Do not wander aimlessly about over the face, but get one part well finished up before attacking the next part. If the work has to be left for a time, the student should continue just where it was left off, or it will never be possible to get it to blend up properly afterwards.



Fig. 460.—CORRECT POSITION FOR WORKING-UP.

THE HAIR.

This must be done in soft, full strokes, with a large brush. Do not, on any account, attempt to indicate separate hairs, because this is impossible; but endeavour to represent locks of hair, or a group of hairs gathered together in the same form. Where the hair does not fall in locks, only the broad mass should be represented, with its outline perhaps sharpened, and a few stray bits indicated very faintly. The locks are the easier to represent.

The great thing is to avoid the lines having apparently either a beginning or an ending. That is to say, one lock of hair should as far as possible fall over another lock (see Fig. 461); this gives a much more natural appearance. By examining the works of great painters and sculptors, the student will find that this is a trick invariably made use of. Notice, also, the way in which various kinds of hair are represented. The most difficult hair is the thin, straight hair of a man who wears it



Fig. 461.—METHOD OF WORKING HAIR. (CONSIDERABLY ENLARGED.)

plastered down on his head; as, besides its natural ugliness, it is all but impossible to give to it any detail, without making it appear hard and wiry. Such hair is better left alone, beyond just a few sharp touches near its edges. When the hair is parted in the middle, and is thin and shiny, the lighting, unless very carefully managed, will have given a partially bald appearance. This should be toned down, by very fine lines drawn out from the centre of the hair on each side of the parting. When the hair is worn rather untidily, or for other reasons has a lot of odd ends hanging around the head, these may be removed.

As they will be, for the most part, darker than the background, they must be scraped away. Of course, such things should preferably be done on the negative, but it frequently happens that even when this has been done there is still some evidence of them in the enlargement. If it is necessary to remove the places by scraping, this should not be done until the other work has been completed; since if it should be necessary to rub in a tint on top of the part which has been scraped, this will take the lead or chalk too easily, and result in a black mark. The same remark applies when black spots are taken out in a similar manner. The touches used in working-up the hair should begin softly, broaden out, and then gradually fine off again into nothing. The appearance of one of these touches, if greatly magnified, would be something like Fig. 462. The strokes should cross one another irregularly in most cases, and gather together the shade, as shown in Fig. 461. It must be borne in mind that any object, when lit from either side, is never lightest or darkest at its extreme edges. The darkest shade comes somewhere between the high light and the edge, but the extreme edge is usually occupied by a reflected light, more or less strong according to the nature of the surroundings. It is the management of these reflected lights which indicates the artist, generally speaking. There should always be, even in the most trifling details, if receiving sufficient light, a high light, half tone, shadow, reflected light, and reflected half light; and it is the presence of all these in each part, and in a larger scale in the whole, which helps to make a perfectly lit picture, of pleasing gradation.

THE DRESS.

The same remarks apply to the dress. As a general rule, except in the case of copies or very bad photographs, the dress receives little or no work beyond gumming of the shadows. This is a reprehensible practice in many eyes, but is nevertheless considerably done. It certainly imparts brilliancy and transparency to the shadows, but has an unnatural appearance, and generally shows badly in reflected light. On

no account is this allowable on a platino-type print. The most artistic way of dealing with drapery is to deepen the extreme shadows with a little broad cross hatching. The high lights may also be heightened with the ink eraser. White satin dresses can generally be immensely improved by this latter treatment. Some attention should be given to the proper rendering of material or texture. For example, a wool and a satin dress should be rendered quite differently. The former hangs in loose round folds, and has soft lights and shadows. The latter makes sharp, angular draperies, with brilliant lights and sharp outlines. Jewellery may, as a rule, be picked out a little with the scraper, so as to render it as striking as possible. Pearl necklaces are the delight of the learner, since they can so easily be made to look effective. Yet a careful study of this will result in the student seeing that the reason they photograph so easily, and can be rendered so well with a few touches, is that they possess that range of tones and reflected lights which it has been pointed out are so essential, and only require that the extreme high lights should be heightened.

PAINTED BACKGROUNDS.

In putting in a vignettted background with the brush, it is customary first to wash in a middle tint, then cross-hatch over this to the desired shade. To do this, first of all sponge over the part which is to receive the wash; then, commencing at the top, with a brush charged with very watery colour of a tint midway between the paper and the desired shade of background, draw lines from left to right across the paper, taking care to finish softly just before it reaches the head, when the moist surface will allow it to spread softly to the head. Make the next line just below, lapping over the previous stroke about an eighth of an inch. These strokes are continued, joining each to the one above, until the bottom is reached. Now set this aside to dry. The washes should be put on with a camel hair mop or a No. 6 brush. The wash will be inclined to run down into the dress, so that this part should not be done

until afterwards. As it gradually drains down, it should be blotted with a clean piece of white blotting paper. When dry, the tone of the background, or clouds, is hatched in by drawing extremely fine lines very evenly from the head outwards, and crossing them at an acute angle, as in the upper portion of Fig. 161. On no account must the lines cross at anything approaching a right angle, as the effect will be hard, and the margins will not soften properly. A considerable amount of practice will be necessary before this can be done easily and neatly. It is essential, also, to ensure the best effect, that it should be done quickly, and with the fewest possible strokes. The student is advised to practise this on drawing



Fig. 162.—TOUCHES USED IN WORKING HAIR.

paper. Draw the outline of a vase or any simple object, and proceed to shade it up by cross hatching in this manner. Cross hatching is not so much used nowadays as it once was, but is capable of giving very beautiful effects if skilfully done.

WORKING WITH CRAYONS.

With the introduction of bromide enlargements, and the consequent immediate increase in the demand for enlargements generally, various methods of rapidly working them up were suggested. Of these, the most popular is the air brush process, described later. A method of finishing which has found considerable favour consists of working the picture with crayons and powdered chalks. Special pencils, both white and black, are obtainable of all dealers. "The Bromide Set," which contains, in addition to pencils, a stump, refills, etc., will be sufficient for a beginner. Ordinary chalk pencils, if soft, may be

used for the same purpose: but they must be a good blue black, and not a rusty brown. This is the difficulty with most chalks; the soft pencils, however, are usually less brown. The same obstacle occurs with regard to powdered chalks, and the best substance will be found to be a mixture of chalk with the ordinary powdered retouching lead. The stippling, or evening, of the face is best done with chalk points. These should be sharpened so as to leave at least $\frac{1}{2}$ in. of chalk out, or if the ever-pointed pencils are used so much the better. The chalk is then rubbed on a glasspaper block until it has a good clear point, in the manner adopted for retouching. Some workers even prefer to use a retouching pencil for the work, but pictures so worked are far too waxy in effect for any but very small sizes. For these, it may occasionally be used:



Fig. 463.—PAPER STUMP.

but it has a further disadvantage, namely, that it gives a shiny surface, and therefore the parts worked upon are easily detected, since they do not match with the surroundings. If, however, the use of this kind of pencil is restricted to the very lightest tones, it will not matter so very much, and it certainly gives the smoothest possible effect. The remarks made about the use of the brush apply with equal effect to that of the pencil. It is a good plan to use always the softest pencil possible. Enlargements upon crayon papers are the most suitable for treatment in this way. Crayon papers have a fairly rough surface, such as is used for crayon drawings. Pictures on such a basis may be finished to resemble drawings in crayon very closely. Any matt surface paper may be used, but the glazed or even smooth papers are unsuitable for this kind of working-up.

STUMPING.

Where a broad shade is required, instead of a sharp shadow, it is best obtained

by rubbing powdered chalk into the grain of the paper. This may be done (*a*) with a stump, (*b*) a leather pad, (*c*) cotton wool, (*d*) with the finger tips. The last three are specially suitable for large work, and the former for small work just too soft and broad to represent with the point. Place on a piece of white blotting paper a little powdered chalk, and with it a little retouching lead in powdered form. That which gets rubbed up in the process of pencil sharpening will be sufficient. A small bundle of paper stumps, of the form shown in Fig. 463, will be required; these cost only 2d. per dozen, so may be used until rubbed down or out of shape, and then thrown away. Take one of these, and well mix the lead and chalk together, trying it on the clean blotting paper before applying to the picture. It is then rubbed on the print to the required depth. Generally speaking, the stumps are all the better when they have been used a few times.

METHOD OF WORKING—SMOOTHING THE FACE.

Commence work at the top left side of forehead, and gradually work downwards. Take the irregularities one by one, and draw very fine short lines through them, until they nearly match the depth of the surrounding parts. This should be done with a fairly hard pencil, as a rule, which has a good point. See that all the lines run in a similar direction. The exact method of smoothing will, however, depend partly on the character of the subject. Where a diffused, out of focus effect is aimed at, smoothing must be done with the stump, which should not be too pointed. Try to do this in a regular manner, as a grain will thereby be imparted to the picture, which will blend together and tend to conceal the working. Be careful to preserve the modelling. See that the forehead (supposing the picture to be lit in the usual photographic style, namely, at an angle of 45° with one side) gathers itself up into four chief lights, more or less decidedly according to its character. These lights should be as follows: two at top, merging into each other, and one over

each brow. Be careful not to put the slightest amount of unnecessary work on the print, as this will lead to every other part being darkened to agree with it, and the result may be that the picture will be made too dark and spoilt.

HEIGHTENING THE LIGHTS.

The chief lights are top of forehead, one on each brow, down bridge of nose, on cheek bone, over upper lip, on lower lip, and on the chin. Each of these must be preserved, and kept in proper tone contrast with the others. Remember that the strongest light will be that nearest the source of light. If the picture is already fully dark, the best effect will be obtained by enlarging and increasing the lights. For this purpose, a stick of ink eraser and a scalpel will be required. The scraper used in retouching may, however, be employed, and answers well. The scalpel referred to is one employed by surgeons, and is obtainable at any surgical instrument maker's. It is essential, whatever is used, that the edge of the scraper should be turned over, to scrape the film to the best advantage. The print must be thoroughly dry. On no account commence to scrape up a picture which is not absolutely dry. Even if the print has stood for a little while in a room, in a damp atmosphere, it will never scrape properly. The best plan is to leave the scraping until last, if working in powders: as powders rubbed over a part which has been scraped always come up roughly, and cannot afterwards be properly smoothed out again. The general rule, therefore, is to smooth the face as much as desirable, and then put in the lights. One cannot emphasise too strongly the necessity for great care that no character in the face is lost. This can only be assured by a thorough knowledge of faces in general, and the keenest observance of their peculiarities. A practical acquaintance with anatomy will be found most helpful.

ERASING AND SCRAPING.

Any ordinary ink eraser may be used, but the form found most convenient is that shown in Fig. 464, which may be used for

narrow lines and small spaces. If the print is not bone dry, it should stand in a warm room some little time before rubbing, to get the best effect. Erasing or scraping must be done very slowly. If the worker attempts to hurry it, failure is bound to result. Patience is the most important part of the process. It is the easiest thing imaginable to rub right through the film, but even if it is necessary to do so to obtain the desired effect (and this is very rare) it is far better to do it gradually, getting deeper and deeper towards the centre. If done rapidly, it will have hard edges, which no amount of after work can ever make to look so well. As a general rule, it is merely an infinitely thin layer which has to be taken off the surface; and if properly done the effect is to smooth instead of roughen it.

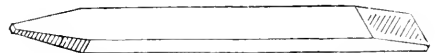

Fig. 464. — BEST SHAPE FOR INK ERASER.

OTHER METHODS OF HEIGHTENING THE LIGHTS.

Where broad spaces have to be reduced, a leather stump dipped in cuttlefish powder gives the best result. This soon gets embedded in the leather of the stump and rubs smooth, so that it should be dipped occasionally in the powder. The powder is obtainable from any chemist, and must be fine and free from bits of grit. Paper stumps are not so suitable for this, since they so rapidly rub smooth and cease to take effect on the print. Another method of heightening the lights is by chemical reduction. If the print is a bromide, it may be very successfully reduced with a solution of iodine in potassium iodide, as used for removing stains (see p. 235). This is applied to the print with a brush. Lay the dry print face up in a dish, and paint over the part needing reduction. The strength of the solution must be varied according to the desired tint. It is not advisable to use it very strong, as, if not sufficiently reduced, the operation may be repeated. The effect of the solution will be to turn it to a blue

violet colour; and a weak solution, say 10 per cent. of hypo, should then be poured over the print for an instant, when it may be washed and dried again. Carbon prints and platinotypes are not suitable for such

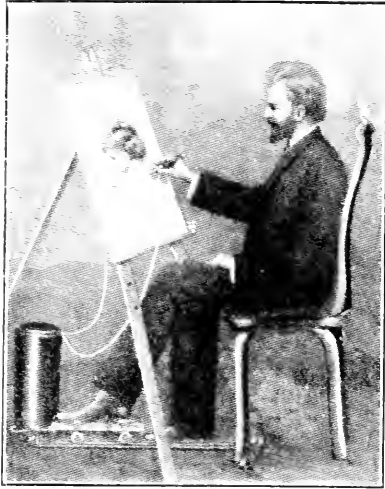

Fig. 465.—AEROGRAPH IN USE.

treatment, but these allow of scraping easily.

CHALK BACKGROUNDS.

Backgrounds put in with chalk are the most effective, and even if the face is brush-

tions of which may or may not appear in the enlargements, according to the lighting, exposure, etc. In any case, the picture will be immensely improved by some additions in this respect. Take a tuft of cotton wool (about the size of a large walnut for a 12 in. \times 10 in. picture) and dip it in the powdered chalk. Now rub it vigorously on a sheet of blotting paper until perfectly smooth, and so that it makes an even tint not darker at centre or edges. In rubbing it on the blotting paper, it is best to do it with a circular motion. Then rub over the background a tint commencing near the figure and becoming lighter until it disappears near the edge of the picture. The shade must be perceptibly deeper close to the head, and also at the lower part or near the shoulders. The best effect is obtained by having three graduated tints or shades, each finishing in a sort of shamrock shaped cloud, but, of course, not with any decided form. These must not come immediately above each other, but one may be in between the others. To obtain breadth of effect, there must not be too many of them—four or five clouds on each side are ample—and preferably a different number one side from the other. Above all, however, it must be understood that these must appear to be present as if by accident, and therefore the more in-

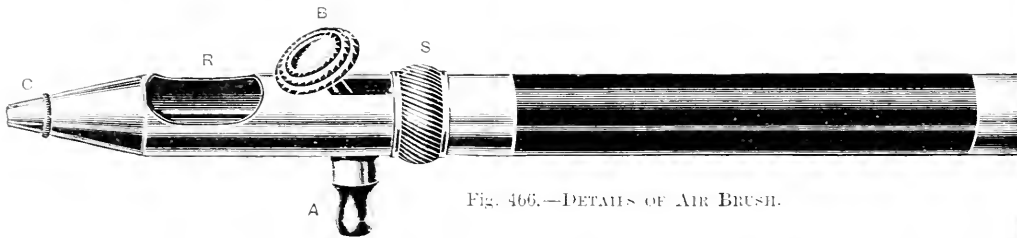

Fig. 466.—DETAILS OF AIR BRUSH.

work it is better to adopt the powder method for the background. It is more easily kept soft and retiring from the figure, while the effects can be obtained so rapidly, and altered and corrected so easily, that it seems to be quite the best method. Head and shoulder pictures, taken for vignetting, are usually against a cloud background, the grada-

definite they are the better. One or two specks of light may appear, generally near the margins and between the divisions in the clouds, and these are put in by soft touches with rubber. Reeves's "soft" rubber is the best for the purpose. Many workers, however, do not care for these touches of light at the margins of the picture, and prefer to omit them.

FANCY BACKGROUNDS.

It often happens, particularly with enlarged "copies" or amateur pictures, that it is necessary to block out the backgrounds and introduce others. This may be done by combination printing (see p. 159); but when only one copy is required, it is simpler to leave the matter to the artist. The first thing is to look round for a suitable subject. Generally speaking, though not absolutely necessary, it is best to choose some indefinite sort of subject, an example of which may usually be found in the studio, and can be used as a guide. First make a rough

rubber, as in cloud backgrounds. For a very smooth surface, the leather pad is perhaps best. For the actual sketching in of the background, practically no instructions can be given, as it will depend entirely on the subject and the taste of the worker. Keep the details subdued, avoid straight lines, and see that everything harmonises in tone with the figure, and all will be well.

THE AEROGRAPH OR AIR "BRUSH."

This is an apparatus for spraying fluid colours on to any surface, by which a beautifully stippled effect can be produced with a minimum of trouble. Fig. 165 shows

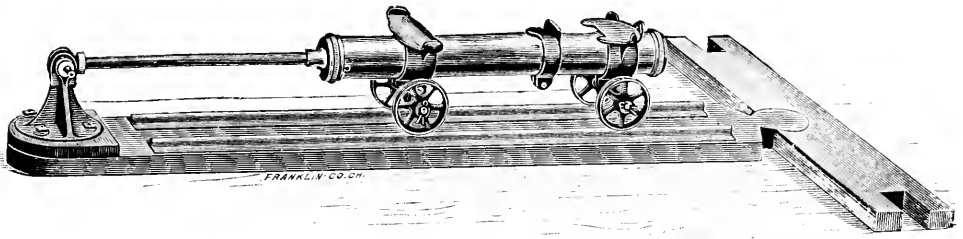

Fig. 467.—FOOT PUMP FOR FILLING RESERVOIR.

sketch, just to see how it will come. Now sketch in lightly, on the paper, the position of the different objects with the chalk point: of course, using chalks of a kind to match the paper. It is more frequently bromides which are so treated, negative processes seldom being done in this way, so that black chalks will be mostly needed. The paper should not have a smooth surface. The best effects are obtained on crayon papers. If the paper is smooth it will be necessary to rub it well all over, first of all, with cuttlefish powder on a tuft of wool, to give it a tooth to hold the powder; but bear in mind that this must be done very lightly, or the effect afterwards will be scratchy. The background is then stumped in, using the paper stumps for the details, and the wool, leather pad, or finger tip for the broad shadows, according to taste. A very nice grain, in the deepest shadows, can be obtained with the finger tip on such a surface, and the lighter parts may be afterwards wiped out with the

the instrument at work, while a detailed illustration of the fountain part, which is held in the hand, is given in Fig. 466. The apparatus is worked by compressed air from the reservoir, supplied by a kind of air-pump with a piston action (see Fig. 467). The reservoir is kept filled by an occasional motion of the foot, and the colour is driven out in an exceedingly fine spray. The depth of tint is governed by the length of time the brush is held opposite the part treated, and the breadth of tint by the distance from it. The farther the brush is away, the more the spray spreads, and *vice versa*. The pigment, which may be of any colour, is placed in the brush reservoir r (Fig. 466), using for this purpose a small camel-hair mop. A few motions of the foot pumps sufficient air into the air reservoir to last for some minutes. The amount of air in the reservoir is indicated by a glass gauge, which may be fixed by the side of the case. In Fig. 465 the gauge will be

noticed hanging over the top of the enlargement, and connected by a tube to the

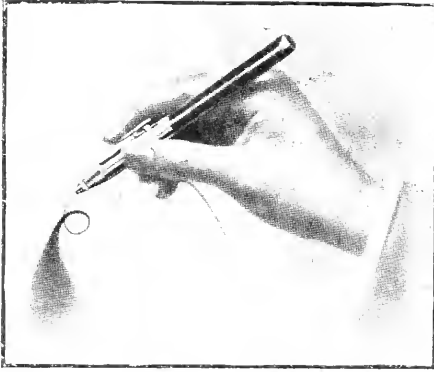
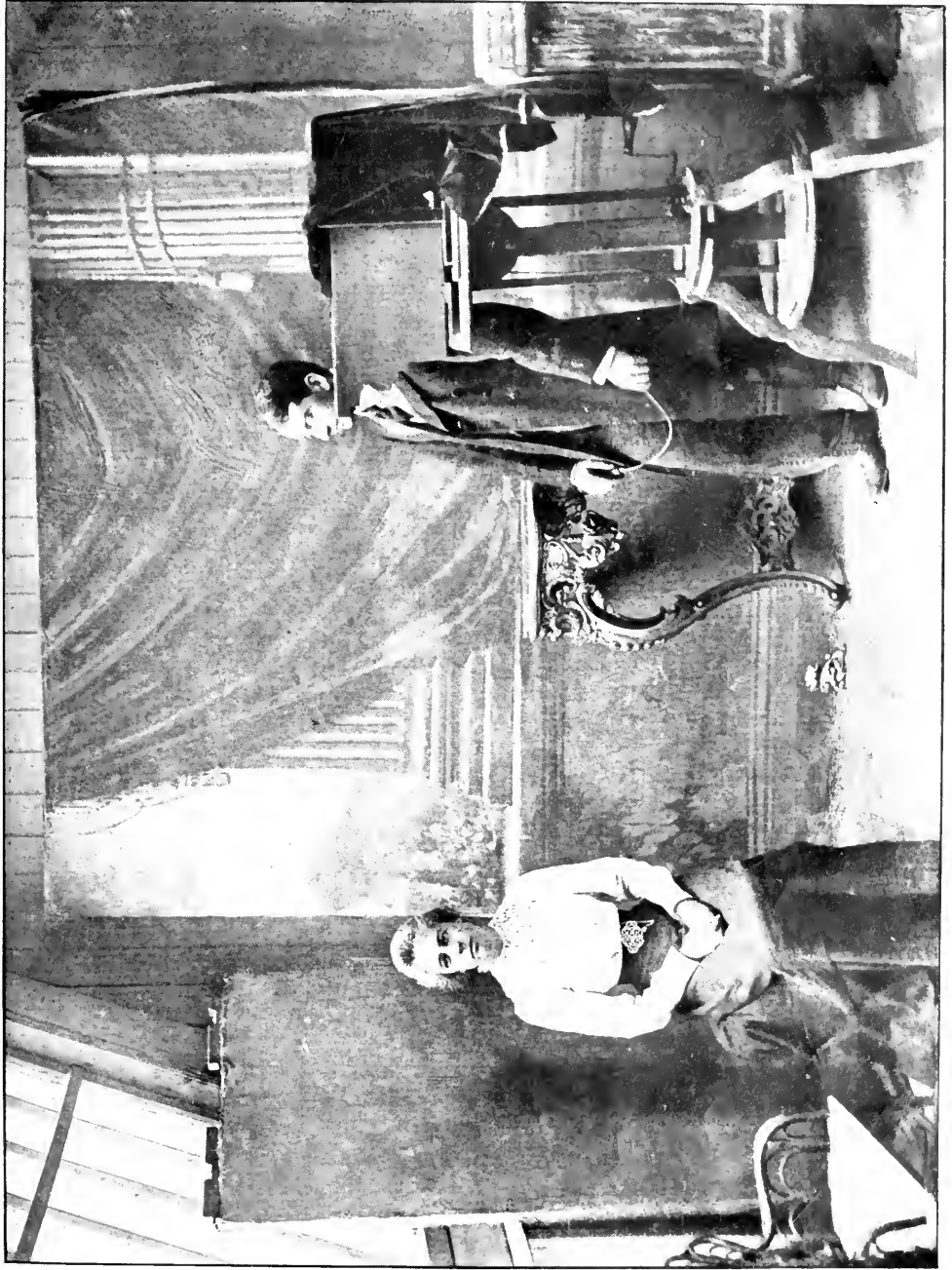

Fig. 468.—DISTRIBUTION OF COLOUR BY AEROGRAPH.

air reservoir. As soon as the gauge gives warning that the air is becoming exhausted, the foot pump is again set in

motion. The air enters the brush through the tube connection at A (Fig. 466), and is released by a downward pressure on the button B, which also controls the amount of air, and consequently colour, emitted by a backward or forward movement. The colour is driven through the opening in the nozzle, C. The ring S may be used to limit the forward motion of the button or lever, thus regulating the width of the line if desired. The instrument is admirably suited for coloured work, and it is an advantage that the surface of the picture requires no preparation. Fig. 468 shows the manner in which the colour is distributed. The apparatus is easy to manipulate, and gives charming results. Its purposes must not be misunderstood, however. It requires the same artistic skill in the arrangement of tones, etc., and its success depends as much on the expertness of the user, as with any other brush.



STUDIO WORK: TAKING HEAD AND SHOULDERS PORTRAIT

METHODS OF COLOURING PHOTOGRAPHS.

THE ART OF COLOURING.

THE various processes which have been invented for producing by natural agencies a coloured impression more or less resembling nature will be described in the section on "Photography in Colours." It is now proposed to deal with the different methods of imitating the effects of ordinary water- and oil-colour painting, using the photograph to supply the necessary proportions and more or less detail. First will be described the methods in use by first-class colourists, then the various trick processes by which water-colour effects may be produced. A little practice in water-colour painting will be a useful preliminary. By carefully copying good pictures, many of the points dealt with will be brought home to the worker in a way that no amount of writing about them could possibly do. The art of colouring is not to be easily acquired by the knowledge of a few rules. Good work can only be done after considerable practice, although it is possible for persons with merely a taste for colour to produce very effective pictures. An intimate knowledge of the laws of colour harmony is, however, of first importance.

PRIMARY COLOURS.

There are three primary colours from which all the other shades and tints are made up. These primaries are red, blue, and yellow. The red and yellow and their combinations are called "warm" colours; while blue, violet, and green, or combinations of blue, are "cold" colours. With regard to the blending of colours, it may be pointed out that the mixing of coloured lights and the mixing of pigments are not quite the same thing. The varied combin-

ations of colours are called hues, and these hues, when they are thinned down and made to appear lighter by admixture with white, are called tints. If they are mixed with black or made more opaque they are called shades. The various gradations of tints and shades of the same colour are called a scale.

SECONDARY AND TERTIARY COLOURS.

When two primary colours are mixed, they form what is called a secondary colour, which is complementary to the third primary colour. For instance, red and yellow form orange, which is a colour complementary to blue. In a similar way, the other colours may be combined with like result. The principle may be carried still further. Two secondary colours may be combined to form what is called a tertiary colour, which is complementary to the remaining secondary colours.

HARMONY.

When the colours are in proper relationship, it is called harmony. Now this harmony is of great importance, for it governs the success of a picture. The charm of colour work does not lie in the colour itself, but in the blending or harmony of the various tints and shades. Fig. 469 gives a very good illustration of the effects of colour combination. This may be prepared by drawing a circle and painting spaces A, B and C blue, C, D and E yellow, and E, F and A red. It will be seen that three primaries and three secondaries are produced, each of which is opposite to its complementary, the harmony of the combination being very pleasing. It is a curious fact that after gazing fixedly at

a colour the eye itself will conjure up the complementary. A familiar example of this will be demonstrated by cutting out

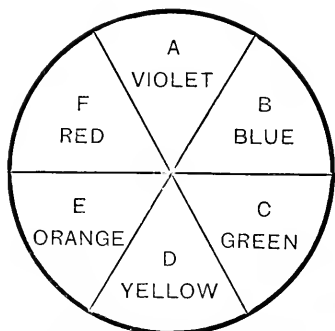

Fig. 469.—DIAGRAM ILLUSTRATING COLOUR COMBINATION.

two stars in red and white paper respectively, and fixing one beside the other on a neutral ground, as indicated by Fig. 470.

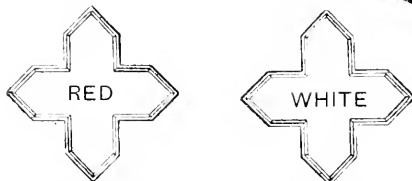

Fig. 470.—EXPERIMENT IN VISUAL FATIGUE.

By looking at the red star for a few minutes, then at the white one beside it, a green and white star will be seen. This is due to the phenomenon known as "visual fatigue." In the example under consideration, those muscles of the retina which convey the red sensation to the brain are, as it were, exhausted by constantly gazing at that colour, and refuse any longer to perform their function. As a consequence, the two remaining sets of retinal muscles, those giving rise to the green and blue-violet sensations, are alone in action, and on looking at the white star it appears to be green. For, as is more fully explained in the section on Photography in Colours, the sensation of white light is compounded of the three primary

sensations caused by the simultaneous excitement of three sets of nerves in the retina. When, therefore, one of these sets of nerves is temporarily thrown out of action by fatigue or other cause, a white object no longer appears white, but is seen in the complementary colour to that which is missing.

PROPERTIES OF COLOURS.

As already indicated, certain colours give an impression of warmth, and others

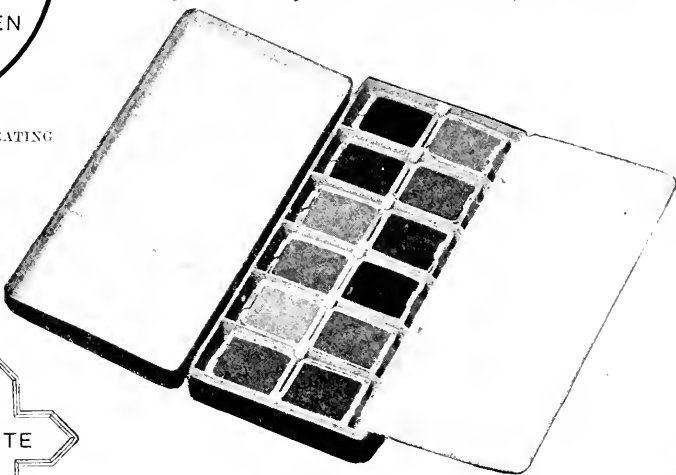

Fig. 471.—JANNED TIN WATER-COLOUR BOX.

an impression of cold. Warm colours have the property of approaching the eye, whilst cold colours recede from it. Thus, if a figure is required to stand out from the background, it should be painted in warm colours, and the background kept cool in tone. Every tint, however complex, as it approaches to either of the two extremes, red or blue, obeys the same law. Again, colours possess varying intensities. The darkest or least intense colour is purple, whilst the brightest colour is yellow, its complementary. Although yellow is that which appears brightest, it is not the most exciting colour. Red occupies this position, and, as may be supposed, the complementary to red has the opposite effect, being the most soothing colour. It is also evident that colours which are complementary to each other have their contrasts increased, whereas those which are not

complementary are subdued in contrast and lose their purity. The same rule applies to the blending of colour and absence of colour, black and white. If a black is to look deep, pure, and rich it should be opposed by red, yellow, or orange; if opposed by blue or green, it appears brownish. The knowledge of these simple facts is often acquired intuitively, but time is saved and confidence gained if the novice makes himself familiar with the rules stated above.

Indigo. Naples Yellow.—A not very permanent colour; useful for flesh tints. Yellow Ochre.—Used in painting fair hair, and sometimes for backgrounds. Orange. Vermilion. Rose Madder.—A good transparent colour suitable for delicate flesh tints. Aureolin. Viridian. Carmine.—Useful in flesh tints; works well, but not permanent. Terre Verte. Chinese White. The colours can be obtained in either cakes, pans, or tubes. Moist colours in pans are, perhaps, the most convenient. A japanned

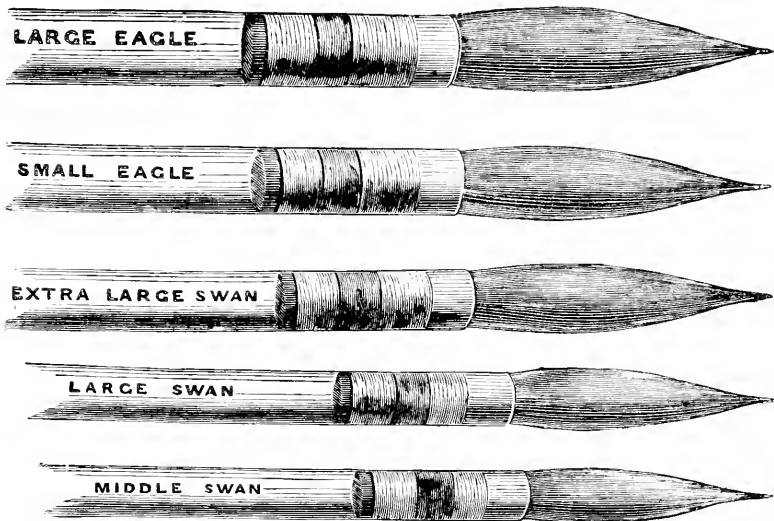

Fig. 472.—SABLE HAIR BRUSHES IN QUILLS.

MATERIALS REQUIRED.—WATER-COLOURS.

The first requirement will be a set of suitable water-colours. The following is a complete list of all the colours likely to be required:—Sepia.—This is a transparent brown which may be used for hair and draperies; it is somewhat cool in tone; when approaching more to red, it is known as warm sepia. Brown Madder.—Useful in the shadows of draperies; when used with blue forms a pleasing grey tint suitable for shadows in the face. Raw Sienna.—Useful in backgrounds. Burnt Sienna.—Also used in backgrounds, and sometimes in the face for flesh tints. Raw Umber, Burnt Umber.—Used for hair. Light Red.—May be used in flesh tints. Antwerp Blue, Cobalt.—Used to grey the shadows.

tin box, of the kind shown by Fig. 471, is best for keeping them in, and can be procured empty, so that any assortment of pans may be bought separately to fill it. A box is, of course, not necessary, but is strongly recommended.

BRUSHES.

These should be of the very finest sable, having a good spring and capable of coming to a perfect point. The best test for a brush is to bend the point lightly back when dry. If it does not recover its shape or appears bushy, it is unsuitable. Next the brush should be moistened and drawn back across a clean sheet of blotting-paper, giving it at the same time a circular motion to bring it to as perfect a point as

possible. Fig. 472 shows the type of brush required. Those illustrated are in quills, but they are also obtainable in metal ferrules, which certainly are less liable to split. The brushes most useful are Nos. 3 and 4, and if in addition Nos. 1, 2, and 6, and a fair-sized camel-hair mop (Fig. 473), are provided, these will be sufficient for all practical work, although a good deal will depend upon the size of the picture to be treated. The novice will do well to keep to 5-in. or 6-in. heads for a time.

OTHER ARTICLES.

The next requirement is some gum solution, which may easily be made by dissolving a few clear and clean lumps of gum arabic in warm water. The gum should be

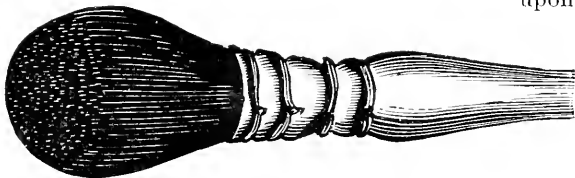

Fig. 473.—CAMEL-HAIR MOP.

allowed to soak for some time, if possible, at a gentle heat, such as may be obtained by placing the vessel on the hob, not too near the fire. It must be stirred occasionally, and, when practically all dissolved, is strained through muslin to remove any lumps or grit. There will be needed a china palette about 8 in. by 5 in. : one or two porcelain trays of the form shown in Fig. 474, which are used for holding washes of light tints : a little powdered pumice : a clean piece of rag for wiping out, trying brushes on, etc. : a few paper stumps : and some ox-gall, in either liquid or solid form, the former being the more convenient.

PRINTS.

A suitable print will also be required for experimenting purposes. Carbon, bromide, platinotype, albumen, and plain salted prints all lend themselves to this treatment, but glossy P.O.P. is unsatisfactory. The albumen is perhaps the best

to begin with, or, failing this, a bromide, which will probably be the easiest to obtain of a suitable size, although the grey tone is a little trying to the colourist at first. A 12 in. by 10 in. bromide, preferably a contact print, will answer well. Choose one in which the gradation is good. It should be full of detail, soft, and yet with good contrast. In short, the more perfect the picture, the better the result. Heavy masses of shadow and bald patches devoid of detail cannot be treated effectively. The printing should not be too dark or heavy, but only just dark enough to show the detail in the high lights clearly. Another print will be required as a guide. This need not be of the same size, but must be the same picture, and should be much darker than the one being worked upon, so that in the coloured print there



Fig. 474.—DIVIDED PORCELAIN TRAY FOR WASHES.

is full detail in the shadows, and in the guide print full detail in the lights.

MOUNTING.

The print must first of all be mounted and allowed to get bone dry before being used. It should then be attached to a drawing board with pins and set up at a convenient angle. For work of any size, an easel is a great convenience. Two simple and inexpensive patterns, well suited for the purpose, are illustrated by Figs. 475 and 476. The best plan is to "rough"-mount only, or to mount first on a plain card, and after painting, in a cut-out mount. When this is not possible, as when the picture is required upon a tint mount, a paper shield should be cut out to protect the margins from becoming soiled. A sheet of brown paper is taken somewhat larger each way than the mount, and an opening cut in the centre the size of the part to be painted. The margins

are then turned over and sealed down with a little wax.

PREPARING THE PRINT.

The first operation is that of preparing a suitable surface on which to work, just as a medium is used to supply a tooth for the pencil in retouching. Unless this is done, the surface will be greasy and the washes will flow badly, and very fine stippling will be almost impossible. This must be done by rubbing the surface of the print

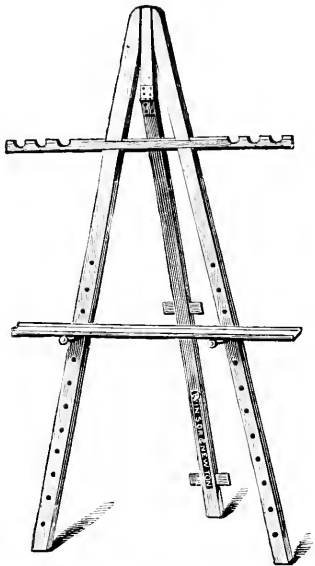

Fig. 475.—CLOSING EASEL.

with powdered pumice on a tuft of cotton-wool. The powder should be applied with a circular motion, giving an even pressure throughout to avoid scratchiness. Only the finest pumice should be used for this purpose, the coarser varieties being quite unsuitable.

COATING PRINT WITH OX-GALL.

The next operation is to flow the surface with ox-gall. If this is in the solid form, a little is taken and dissolved in warm water. Whichever is used, take up the largest brush, preferably the camel-hair mop, dip it in the solution, and, commencing at the top left corner, draw the brush

backwards and forwards all over the picture, keeping it well charged with solution the whole time. In this way the picture will be completely covered with an even coating of solution. It must then be stood aside to dry. It is of great importance that the surface should be in a proper condition for working. If the solution is too thin or the application too scanty, the colours will sink in instead of flowing freely. For this reason it is better for the

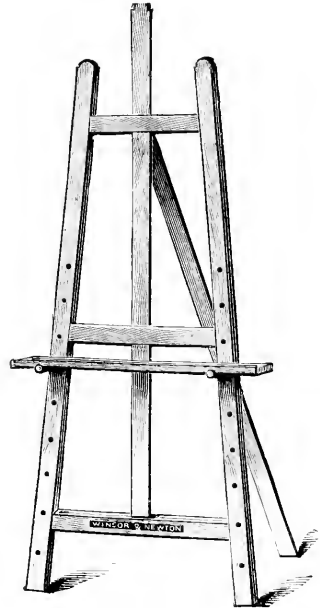

Fig. 476.—FRAMED OR STANDING EASEL.

novice to use the prepared solution. When dry, the surface may be tested by applying a little colour to one corner and noting the result. The photograph should not be too dry or the colours will not take properly, so that if this is suspected it should be washed down with clean water and allowed to dry again.

APPLYING THE COLOURS.

The first operation in colouring a photograph is that of putting in the washes. Washing consists of flowing over a large space an even tint of colour. This requires a little practice to do it perfectly, but once mastered it may be done rapidly

and with extreme ease. As the terms are sometimes confused, it is advisable to point out the difference between painting or colouring and tinting. Photographers understand by colouring that the picture is to be dealt with in detail, so that every tint and semi-tint, every light and reflected light, is to receive complete attention; but by tinting is understood merely the flowing over of a few of the most important colours, giving roughly a general impression of the colouring. This latter is done entirely by washes, whilst in the former the washes merely form the basis of the work. In laying on a wash of any extent,

white paper and the colour then mixed to match it. Now turn the photograph upside down and slightly tilt it, and, beginning at what is now the top left-hand side of the portion to receive the wash, draw the brush well filled with colour from left to right. Where the space to be covered is large, it is usual to float on the colour in this way. If the brush does not cover the first time, give another stroke from left to right below it, and just overlapping. Continue in this way until the whole is covered. Where the space is small, the brush is well charged with colour and put on in one circular sweep, filling the whole

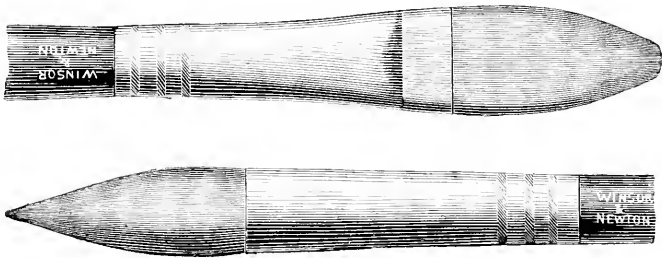

Fig. 477.—SKY OR WASH BRUSH.

particularly if the print is large, it is advisable to use good-sized brushes. Except in very expert hands, the attempt to cover a wide surface with a small brush is likely to result in a patchy and uneven effect. A brush of the kind shown by Fig. 477 is occasionally very useful; it is known as a "sky" or "wash" brush.

THE FACE.

The face and hair should be put on as rapidly as possible after each other, to prevent any appearance of a line between the two, so it is advisable to have both colours ready mixed in the tray. To make the flesh tint for the face, take vermilion or light red mixed with yellow ochre, or Indian yellow or Naples yellow, and mix in the proportions required to make the tint. In the other division of the tray have the colour mixed to match the hair. It is advisable always to have a little piece of hair as a sample, which should be laid on a sheet of

space almost at the same instant. Too much colour, however, must not be laid on the print. The object of turning the photograph upside down and tilting it is to enable the colour to overflow into the hair, where it will do less damage. In putting on washes always arrange that the lighter shade runs into the darker one, and not the reverse. All the washes required in the picture should be put in at the same time. After the face has dried, put in the shadows, such as the nostrils, etc., with light red or brown madder. The hands are treated in the same way as the face.

THE HAIR.

The shadows of the hair may then be worked over with gum, to brighten them and to give transparency. The colour of the hair, of course, varies in every case, so that exact instructions as to colouring cannot be laid down. Those given apply to a medium shade of brown. For hair inclining to a chestnut brown the wash may

be burnt umber, while hair with an auburn tinge may have the shadows lined up with a little crimson lake. In painting hair, the greatest care must be taken that it gathers itself up into locks as far as permissible. Regular lines do not give a good effect, but make the hair look wiry, coarse, and unnatural. In some shades of brown hair a little green may be hatched in, but only a mere trace. For really black hair, indigo may have mixed with it a little red and yellow; this gives an exceedingly deep black. This is seldom mixed, it being less trouble to use Indian ink or lampblack. The shadows may be warmed up with vandyke brown. The shadows of grey hair may be worked in with burnt umber. For flaxen hair, use yellow ochre for the general tint.

THE LIPS.

The lips may next receive attention. The lower lip may be done with vermilion and rose madder, and the upper lip with carmine. For this purpose use a small well-pointed brush, and apply the colour as far as possible in one sweep. The novice must learn to acquire freedom of touch; that is, he must obtain his effects in one operation of the brush, as a series of applications produces a dirty, muddled effect. This, however, can only be attained after considerable practice. It is a common mistake of the beginner to make the lips far too red, or to unduly accentuate the outline, which gives a curious pursed-up appearance. Faults of this description must be carefully guarded against.

THE CHEEKS.

A little vermilion and carmine or rose madder or pink madder is next taken and set on the palette. If the pan colours are used, an old brush should be kept for the purpose; the cake colours may be dipped in water and rubbed up on the palette. A little of this mixture is taken on the top of a No. 1 or No. 2 brush and stippled very lightly into the flesh tint to give the desired colour. Be careful not to overdo this. It is better to err on the side of putting too little rather than too much

colour into the cheeks. The colourist should obtain accurate information on this point, by seeing the subject of the picture, if possible, and making a mental note. The face should then be stippled or evened up, after the manner of the smoothing adopted in retouching. The colours used depend upon the complexion. Various combinations may be used, such as Indian yellow, yellow ochre, or cadmium yellow, incorporated with light red, vermilion or Indian red. Use a suitable brush and keep the paint as dry as possible so as not to disturb the colour beneath, which should be quite dry. The half-tones of the face may then be stippled. For sallow complexions raw sienna may be used. Under the eyes should be a light blue grey or the temples a green grey. Hatching is often preferred to stippling for the broader tones.

THE EYES.

The eyes must be worked chiefly in lines; that is to say, neither washes nor stippling should be employed. If the eyes are brown, proceed as follows: The pupil is first put in with sepia, and then the iris is put in with burnt sienna mixed with a little Chinese white, by means of curved strokes, somewhat after the manner shown in Fig. 457. The outer margin of the iris may be indicated by a thin line of sepia. The light and reflected light are finally put in with Chinese white. If the eye is blue, the pupil may be put in with indigo, the iris with cobalt and Chinese white mixed, the line around the iris with indigo, and the lights with Chinese white, as before. If the eye is grey, a little burnt sienna mixed with the blue will give the desired effect, varying the proportion of each to produce the desired shade. Do not use a very small brush for the eyes. A No. 3 will answer well for a 6-in. head.

THE EYELASHES.

The lines referred to in the last case must be exceedingly fine, and for the eyelashes they need to be finer still. They must never appear as lines unless looked at very closely. The eyelashes of the lower lid are usually wider apart than

those of the upper lid. The lines must not be straight, but should curve out from the centre to the margins. The colour to use is sepia, reduced to the proper tint. This is a part of the work which is often overdone, even by artists of experience. Until, therefore, the pupil feels confident of his lightness and precision of touch, and of his ability to resist all temptation to exaggeration, it will be better, perhaps, to leave the eyelashes severely alone, in work of any importance.

BACKGROUND.

If the background is vignettted, wash on a light colour and work in a darker one near the body. If possible, the background should be a little darker near the lighter side of the head and lighter near the darker side, as this makes the head stand well away from the background. The colour for the background, it will be understood from what has been already said, should preferably be cold in tone, but of a colour complementary to the chief tone of the figure. In putting in all washes it is well to commence with a tone a little lighter than what is really required, as it can always be deepened, but cannot be lightened. Do not on any account use Chinese white to lighten the colours, as it turns yellow after a time, and the effect is bad. The same remark applies to mixing up the colours. They should be thinned down with water to the desired tint if found to be too deep. Chinese white should never be mixed with them for general work, as it renders the colour opaque, and buries the detail and soft tones of the picture. Olive green is a favourite tone for the background.

MAKING ALTERATIONS.

The fewer the alterations the better. In fact, so much more skill is requisite for carrying them out properly that a novice will do well not to attempt them. If the matter is serious, it is better in most cases to wash off completely and begin again. Bromides and albumen prints wash off very cleanly, but platinotypes do not. P.O.P. will wash off, but generally leaves the surface more or less greasy, and the

colour is apt to rake up. The knife or scalpel mentioned in the preceding section (p. 333) will often prove extremely useful for making slight alterations. It may be employed, in a series of very gentle and cautious strokes, to lighten a tint which is too obtrusive, or to break up in a fine stipple any portion which seems heavy and clogged. It should not, however, be used for any effect which ought properly to be done by the brush.

DRAPERY.

This may be treated the same as the background. Chinese white may be used sparingly in the high lights, but it should be remembered that the interest centres on the head, and therefore, generally speaking, the background should be kept low in tone, or at any rate subdued. White muslin must be lightened up generally in this way, with grey shadows. The colours used throughout the painting should be as far as possible transparent.

FINISHING OFF.

A picture treated as described above, but without so much of the stippling recommended, is in the tinted stage, but much more remains to be done to produce the best effect. When the background and draperies are put in, the colouring of the face will probably seem too faint and weak by contrast, and further colour will have to be stippled in. The extreme shadows may, if necessary, be further deepened and blended into the lighter tints by judicious stippling. A little green may be stippled into the eye socket. The reflected lights may be stippled with the faintest tinge of carmine. The edge of the upper eyelid may sometimes be touched with light red, and the corner of the eye near the nose may be given a minute speck of carmine or rose madder, which imparts a bright sparkle to the eye. The deepest shadows may be put in with sepia mixed with a little gum. The edges of the chief washes should be gone over with a clean brush, and nicely softened. A little grey may at times be worked in with advantage. The hands may be given a little extra work also, by touching the joints with a little

rose madder. This, if effectively hatched into the flesh tint in fine lines running across the modelling, gives a very pleasing effect. Gold ornaments may be painted with burnt umber in the shadows, and Naples yellow mixed with Chinese white in the lights. Where the photographic impression is darker than it should be, as, for example, in the case of a soldier's red

essential. A specially designed colour box for miniature painting is illustrated by Fig. 478. The dotted lines show a white-wood panel-desk, which slopes at a convenient angle for working. Miniatures of any size are firmly retained in position by means of two bars adjustable by spring screws. When not in use, desk and miniature slide into grooves in the lid.



Fig. 478.—MINIATURE PAINTER'S BOX.

coat, opaque colours must be used to bury the detail, which is then sketched in again from the guide.

MINIATURE PAINTING.

It is now much the fashion to colour small photographs after the style of the old ivory miniature. The method of working is practically the same as that already described, except that very much finer work and more delicate detail is required. A carbon print is perhaps the most satisfactory for working on, but this is not

PASTELS.

Pastel colours are opaque, and are exceedingly fugitive. They may, however, be used very effectively in doing backgrounds, and enable the work to be done much more rapidly. A very light print of a cold colour should be chosen. The hints with regard to colouring already given will still hold good, the difference lying in the method of applying the colours. The broad tints are rubbed in with the fingers, whilst the details are stippled or hatched in with the point. The colours may be

obtained in a large number of tints, and this is preferable to mixing them. The tints may, when necessary, be hatched over with a point of a different colour.

FIXING PASTELS.

The picture existing as a fine powder on the surface only of the print is extremely liable to injury. Perhaps the best way to deal with pastels is to mount them up at once against a sheet of glass. Various methods have been suggested for fixing them, such as spraying with a weak solution of rice water. Another method

will in this case be much easier, as the exact tints will be at hand for comparison.

PAINTING PHOTOGRAPHS IN OILS.

The method used in painting in oil depends, to some extent, upon the materials used. Transparent colours may be handled in a manner different from that adopted with opaque pigments. The former permit the shades of the picture to show through, and thus preserve the drawing; but opaque colours bury the fine drawing under the first tint, so anyone using opaque colouring must have a good

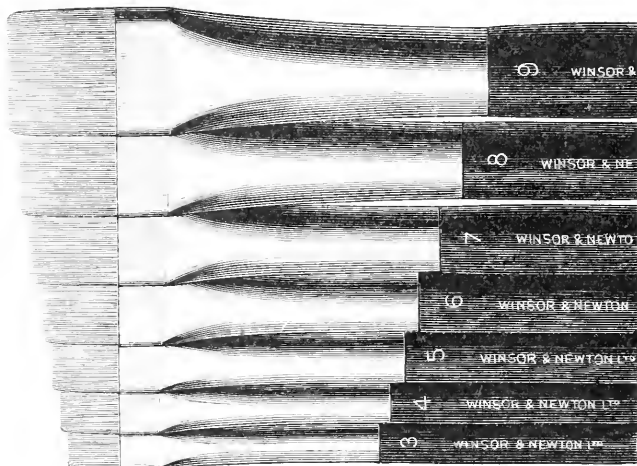

Fig. 479.—HOG-HAIR BRUSHES FOR OIL COLOURS.

consists of straining over the picture very lightly a sheet of thin nainsook, and then very rapidly and lightly brushing over a weak solution of isinglass. The operation requires extreme care to avoid disturbing the colours. A "Fixatif" which is very suitable for this purpose can be obtained of any artists' colourman together with a spray diffuser for applying it to the picture.

PAINTING FROM A COPY.

In first attempts at colouring it is a good plan to take a properly coloured picture as a guide, by obtaining a photographic copy. This should then be coloured to match the original. The work

mastery of drawing. An artist who is able to paint a portrait in opaque oil colours requires no photographic basis. The advantage of using such a basis lies merely in the saving of time. The use of transparent colours for oil painting (or glazing, as it is sometimes called) certainly permits of less knowledge of drawing; but the effect is always weak, and altogether unlike what an oil painting should be, and is only employed in the production of cheap substitutes. It is for this reason that many artists keep to water colours for painting portraits, but the greater solidity and strength of an oil painting scarcely needs pointing out, in addition to which the latter is more permanent.

CHOICE OF PHOTOGRAPH FOR PAINTING.

Broadly speaking, any photograph may be used as a basis, but the favourites are carbon and bromide. If opaque colours are to be used, the photograph only occupies the position of a sketch, and it is therefore needless expense to use the carbon process. With transparent colours a carbon print is an advantage, but as these paintings have usually to be done

PREPARATION OF THE PHOTOGRAPH.

The print should be mounted on a canvas stretcher, after the manner described in the section on Mounting and Framing Photographs (p. 287), and then be given a coating of thin size, applied in the same way as a wash in water colour work: two applications may be given, of course waiting for the first to become quite dry before applying the

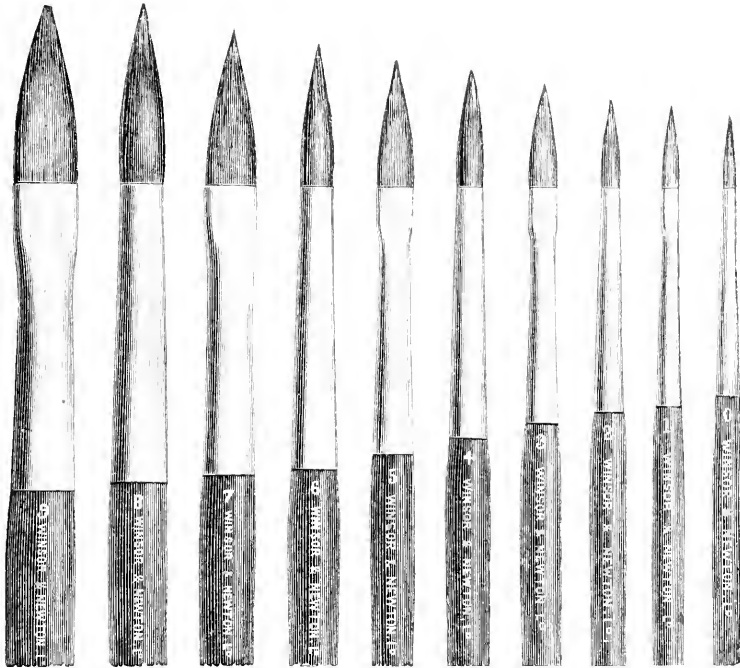

Fig. 480.—SABLE BRUSHES FOR OIL COLOURS.

at the lowest possible cost, the bromide is generally chosen. Not only is the print itself cheaper, but it is not necessary to make a large negative. Many of the best painters use the enlargement merely to make a rough tracing, and this is the best plan. The print is rubbed on the back with charcoal or blacklead, and then laid face up over the canvas. The outlines required may be gone over with a hard point, and the enlargement may then be set up by the easel, and used for a guide during the painting. This method, of course, requires far more artistic skill.

second. A favourite priming for photographs mounted on canvas consists of a solution of thin starch containing a little gum.

COLOURS MOST USED.

In addition to the usual painters' requisites, such as palette, brushes, palette knife, etc., tubes of the following colours will be necessary: Vandyke brown, indigo, emerald green, burnt umber, Indian red, pink madder, light red, raw sienna, Naples yellow, yellow ochre, burnt sienna, vermilion, crimson lake, raw umber, ultra-

marine, ivory black, and flake white. The brushes should be varied both in kind and in size, according to the work. There should be provided hog hair (Fig. 479), long, thin badger brushes, and a few small sables (Fig. 480). A badger softener (Fig. 481) is sometimes useful. A tube of megilp for thinning the colours should also be obtained, and turpentine for washing out brushes. It is decidedly advisable to purchase a suitable japanned tin box for holding the colours and materials, especially as these are apt to get somewhat messy. Boxes are obtainable, both empty

lights. After the first tints have been roughly put in, allow the canvas to dry, then rub over with poppy oil, and remove the excess with a piece of chamois leather. The more delicate tints are now applied. Where very deep shadows are needed, the colours may be rendered opaque by the addition of flake white. In some of the shadows of the face and hair the effect should be greenish. A close observance of nature is, however, the best guide. As to the actual method of applying the colours, little or nothing need be said. It is, however, best to use

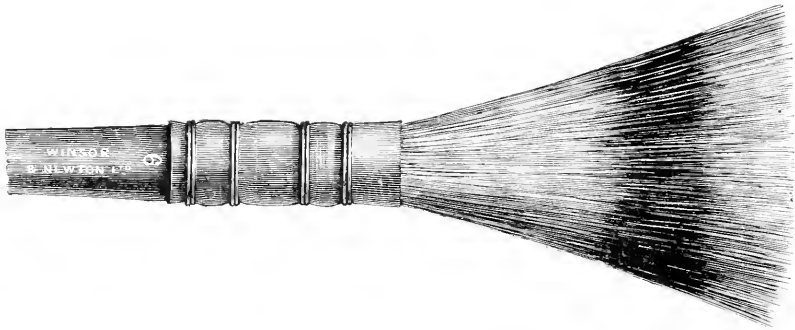

Fig. 481.—BADGER HAIR SOFTENER.

and fitted up, at prices to suit any requirements.

METHOD OF PAINTING.

The method adopted in the actual painting varies considerably with different workers. As before stated, the shadows should be kept cool and the lights warm. It is usual, therefore, to commence by applying a suitable tint to the deepest shadows, and to work from this up to the high lights, using a more solid colour as painting proceeds. The method adopted in water colour work is reversed—the lights being always the last put in. For the deepest shadows in the face use terre verte, raw sienna and brown madder, and sometimes a little light red. This will give a fairly warm grey. Drapery and costumes may first be covered with transparent colour, working into it the various tints for the shadows, half-tones, or high

the long badger brushes for any outlining, and the short hog hair for stippling. The size of the brush is governed by the size of the painting, the boldness with which it is to be treated, and the space it is desired to cover. The colours which may be used can be varied so much, and depend so greatly upon the subject, that the choice is best left to the feeling of the artist, whose experience in water colour painting will be a good guide. The lights are never really white, but a grey partaking of the surrounding tint. In painting draperies it is usual to employ a mixture of two colours, such as, say, brown and blue, using the colder mixture (that is, with a greater proportion of blue) for the shadows, and the warmer for the lighter tones. It is not advisable to lay one colour over the other, but rather to paint round it, leaving a space for the lighter colour.

VARNISHING.

When the painting is completed it is usual to allow it to stand aside for a month or so before varnishing. Either copal or mastic varnish may be used for the purpose. The former being much harder, is a more durable varnish; but the latter is very commonly used, as it dries more easily, and may be removed if necessary without so much trouble. The longer the painting can remain before varnishing the better; but in any case, this must not be attempted until the paint is perfectly dry. A large flat hog-hair

brush when he has acquired the necessary skill in these, he may please himself what dodges he will adopt with a view to saving time or reducing the cost of his work.

COLOURING LANTERN SLIDES.

This operation somewhat resembles retouching in general treatment, inasmuch as it is a question of transparency, and must therefore be done on a support, through which the light may be reflected. An ordinary retouching desk is all that is required, and the remaining apparatus consists merely of a few brushes, a tube of megilp, and the necessary colours.

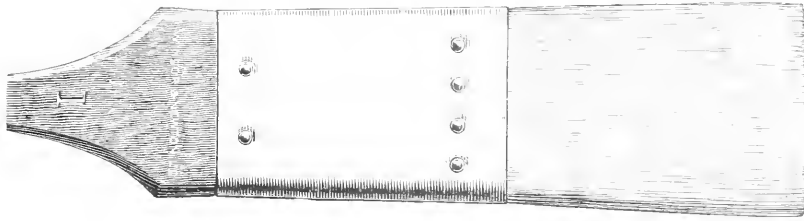

Fig. 482.—HOG-HAIR VARNISHING BRUSH.

brush, of the shape shown by Fig. 482, should be used to apply the varnish, and care should be taken to get a smooth, even coating, free from lines or streaks. Many workers, however, prefer to leave the picture unvarnished.

DODGES.

Besides the plan already referred to of applying transparent colours, there are other dodges for producing imitation oil paintings. For example, it is possible to rub in the face in pastel, and to paint the background fairly solid with oil, and the lighter and sketchy parts with water colours, using the three mediums all on the one picture. The powder is then fixed by carefully steaming over a kettle until it sinks into and becomes part of the film below it. The picture may then be varnished, and to uneducated eyes it will look very like a genuine oil painting. Such work is, however, only trickery, and it is much better for the student to keep to methods of legitimate painting.

which must all be transparent. Oil paints are chiefly used, although special water colour paints are now obtainable. Brushes are very little used, except for fine detail, and a No. 1 and No. 2 are all that are required. All broad tints are put in with the finger tip, and as the colouring of slides is best kept to broad tints, it will be seen that the use of the finger is the most important part of the operation. It is only after considerable skill and experience have been obtained that it is advisable to attempt detailed colouring. A box of oil colours and materials specially designed for elaborate work in this direction is illustrated by Fig. 483.

METHOD OF WORKING.

First decide as to the colours or tints of the various parts; then proceed to colour the larger patches, and afterwards put in the smaller detail. The colouring having to be of an impressionistic character, it is best for the beginner to apply it to the glass side of the slide; this being a little dis-

tance away from the plane of focus, will prevent its being sharply rendered when projected on the screen, and will therefore allow of its being more roughly done than it otherwise would need to be. Take a little of the necessary colour, and add sufficient megilp to cause it to run easily, and mix with the finger tip; smear a little over the centre only of the patch to be treated, and proceed to tap lightly upon it with the tip of the finger. The first application of the paint must be rather thick, so that when tapped upon with the finger it may be spread out into an even tint, and at the same time thin the colour to the right depth. The chief difficulty to be overcome will be that of obtaining a tint perfectly even. Probably, the first attempts will result in a patchy effect, but the tapping must be continued until this disappears. When spread fairly evenly, select all those portions where the colour appears too deep, and tap them lightly again, so as to spread the colour into the surroundings. If this in turn becomes too deep, dab off again until carried to the margins. In some cases it may even be necessary to wipe off some of the colour with a soft rag, and then spread the remainder, but it is always better to put as near as possible the right amount on the glass to commence with. This can be judged very accurately after a little experience.

PAINTING WITH THE FINGER TIP.

The tapping of the finger should not be heavy, or it will remove too much paint from the glass; on the other hand, it must not be very light, or the effect is likely to be lumpy. Use the side of the finger tip, not the extreme end. Quick and light tapping removes little paint, whilst slow and heavy pressure removes proportionately more. The next difficulty will be that of obliterating the grain of the finger tip. With some persons the grain of the skin is more marked than with others, but in any case the slide should be turned first in one direction and then in another, so as to

cross the markings of the finger and split them up into a series of fine dots. When the tint is complete it may be found to have spread over some other part not requiring it, and this may be wiped off either with a brush or a paper stump. Clouds in the sky may be put in in a similar manner, first by wiping out suitable forms and then dabbing until the outline is lost. It is a good plan to tint in the sky and clouds on the cover glass.

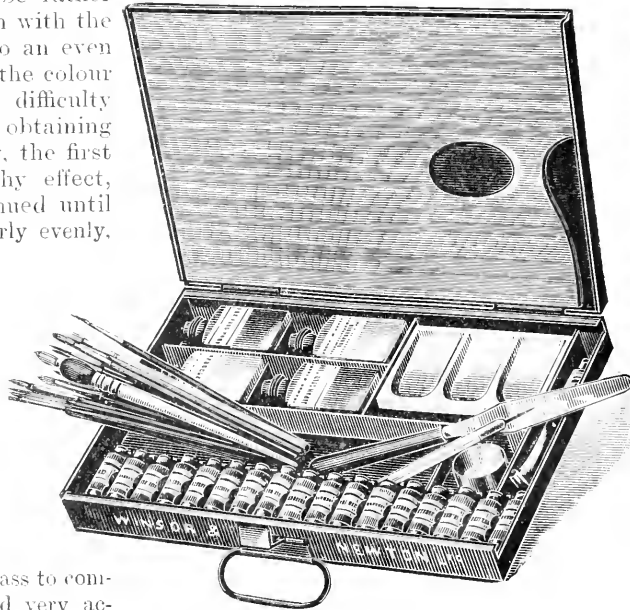

Fig. 483.—OIL COLOURS AND MATERIALS FOR LANTERN SLIDE WORK.

PAINTING WITH THE BRUSH.

When all the large patches of colour are put in, the finer details may be done with the brush. Do not lay on too much colour: it is better to underdo than overdo this. The choice of colours for the various subjects is so wide, that it is best left to the taste of the artist, always remembering to use transparent colours. Often a good effect can be obtained with transparent colours by working one colour into another, as, for instance, in the case of colouring a sunset, where the sky varies through shades of orange red to blue. First attempts should be at laying an

even tint only, and this is best done by practising upon a piece of plain glass or an unexposed but fixed and washed film. When an even tint can be laid with ease, next try a graduated tint, and lastly, the graduating of one tint into another. When the necessary skill in these regards has been acquired, try colouring an open landscape or seascape without much detail. The finer details must, of course, be done on the film side of the slide. A slide for colouring must be lighter and brighter than for ordinary use.

FINISHING THE COLOURED SLIDE.

When the colouring is complete the slide must be set aside to dry, and, as in this condition it is very liable to attract the dust, it must be protected as far as possible. The slide may then be varnished in the usual manner, by flowing over the plate. Be careful not to disturb the colour by pouring on the paint vigorously. Canada balsam and turpentine is a suitable varnish, and can be obtained of dealers in lantern slides. If the colouring is on the glass side, it is very liable to abrasion, but this may be overcome by covering with a sheet of talc.

RADIOTINT PROCESS.

This is a method of trick colouring suitable for those who have no time to learn the proper method. The effect in skilful hands is exceedingly good, and very passable results may be obtained with little or no experience. It consists of the application of three transparent dyes, which may be laid one over the other, and produce a variety of tints.

TINTING WITH DYES, ETC.

There are various sets of aniline dyes and other transparent colours, now obtainable commercially, which are admirably adapted for tinting photographs. Their methods of application differ, but full instructions are generally issued with the colours. As a rule, they are too strong for use until much diluted. A warning is, perhaps, advisable never to put the brush in the mouth when using any of these prepared tints, unless it is absolutely guar-

anteed they are harmless, since many aniline compounds are highly poisonous. For this kind of work the colour should be put on in thin, broad washes, making no attempt to paint in detail. Some of the tints of "Dolly" dyes are very suitable, and may be successfully mixed or blended together.

THE PERMANENCY OF PIGMENTS.

Considering the nature of the image on which the photographic colourist has to work, it is hardly necessary to point out the wisdom of devoting some attention to the permanency of his colours, especially as regards their chemical composition. In some cases certain colours when mixed together set up chemical reactions, and even if they do not injuriously affect the photographic base of the picture, are almost certain to eventually discolour or blacken it. For example, if two lists be made, one containing all those pigments having a copper base, and the other the sulphides of cadmium, then any colour included in the one list, if mixed with any pigment in the second, will set up some kind of chemical decomposition, and can hardly be regarded as permanent, or suitable for the purpose under consideration. In the one group may be placed the cadmium yellows and orange, orient and aurora yellow; in the opposing list emerald and malachite greens and verdigris. Vermilion and Kings' yellow are metallic sulphides; Jaune Brillant, neutral orange, and Naples yellow contain cadmium. Neither of these colours, therefore, can be regarded as safe to mix with any of those in the second list. Chrome orange, red, and yellow, citron and primrose yellows, must not be mixed with Prussian blue or pigments containing it. Organic pigments, such as indigo, Indian yellow, and the lakes, ought not properly to be used with the chromates, nor with aureolin or Mars yellow, the latter being rich in oxide of iron. Chinese and flake white should be of good quality, or they are liable to discolour and injuriously affect pigments mixed with them. Indeed, it is practically imperative that all colours used for this description of work should be obtained from a reliable source.

CHEMICAL COMPOSITION OF PIGMENTS.

It may be of interest to give a list of these pigments which are either actually chemical reagents, or contain such in appreciable quantity, as distinguished from the safer and more suitable colours of vegetable or organic origin.

REMARKS ON FOLLOWING TABLE.

It will not surprise a photographer that such a colour as pure scarlet, which consists of mercuric iodide, should be classed as fugitive. An examination of the list will suggest sundry others which cannot be recommended from a photographic point

of view. Indeed, it is better, as far as possible, to avoid all colours of a chemical composition. Fortunately the number of useful pigments not included in the following list affords an ample choice for all ordinary purposes. It must not, however, be forgotten that among these chemical pigments are comprised some of the most permanent colours known, and that, unless their composition distinctly indicates unsuitability, there need be no hesitation in using them. If there is one thing which the table just given should certainly serve to point out, it is the extreme danger of placing the point of the brush in the mouth, as so many artists persist in doing.

NAME OF COLOUR.	COMPOSITION.	NAME OF COLOUR.	COMPOSITION.
Alizarin	Prepared from coal tar dyes.	Lemon Yellow ...	Barium or strontium chromate.
Antwerp Blue ...	Contains iron ferrocyanide and alumina.	Malachite Green ...	Copper carbonate.
Aureolin	Cobalt potassium nitrite.	Mars Brown... ..	} Earths containing iron oxide.
Aurora Yellow ...	Cadmium sulphide.	Mars Orange ...	
Cadmium Yellow ...	Cadmium sulphide.	Mars Yellow ...	
Cadmium Orange ..	Cadmium sulphide.	Mars Red	
Cappagh Brown ...	Native earth containing manganese.	Naples Yellow ...	Zinc white + cadmium yellow. or lead white, cadmium and ochre.
Cerulean Blue ...	Cobalt stannate.	Neutral Orange ...	Cadmium yellow + Venetian red.
Chinese White ...	Zinc oxide.	Orange Vermilion .	Mercury sulphide.
Chrome Green ...	Chrome yellow + Prussian blue.	Orient Yellow ...	A variety of cadmium yellow.
Chrome Lemon ...	Chromate and sulphate of lead.	Orpiment	See Kings' yellow.
Chrome Yellow ...	Normal lead chromate.	Oxide of Chromium	Chromium sesquioxide.
Chrome Orange } Chrome Red <i>st.</i> }	Lead chromates, more or less basic.	Permanent Violet..	Manganese phosphate.
Cinnabar Green ...	Chrome yellow + Prussian blue.	Permanent White .	Zinc or Chinese white.
Citron Yellow ...	Zinc chromate.	Permanent Yellow	Barium chromate and zinc white.
Cobalt Blue	Alumina and oxide of cobalt.	Primrose Yellow... .	Zinc and barium chromates.
Cobalt Green	Zinc oxide and oxide of cobalt.	Prussian Blue ...	Iron ferrocyanide.
Constant White ...	Barium sulphate.	Pure Scarlet... ..	Mercuric iodide.
Cremnitz White ...	Basic lead carbonate.	Scarlet Vermilion ..	Mercury sulphide.
Emerald Green ...	Aceto-arsenite of copper.	Smalt	Cobalt silicate.
Flake White... ..	Basic lead carbonate.	Terra Rosa	Artificial earth containing iron sesquioxide.
French Vermilion..	Mercury sulphide.	Venetian Red ...	Iron sesquioxide.
Indian Red	Iron oxide.	Verdigris	Copper subacetate.
Jaune Brillant ...	Cadmium yellow + vermilion + white lead.	Vermilion	Mercuric sulphide.
Kings' Yellow ...	Arsenic sulphide.	Verona Brown ...	Earth containing iron.
		Viridian... ..	Hydrated chromium sesquioxide.
		Zinc White	Zinc oxide.





AMPHIPLEURA PELLUCIDA. ZEISS APOCHROMATIC OBJECTIVE 2 MM. WITH COMPENSATION EYEPiece 18. (X 2,340 DIA.)

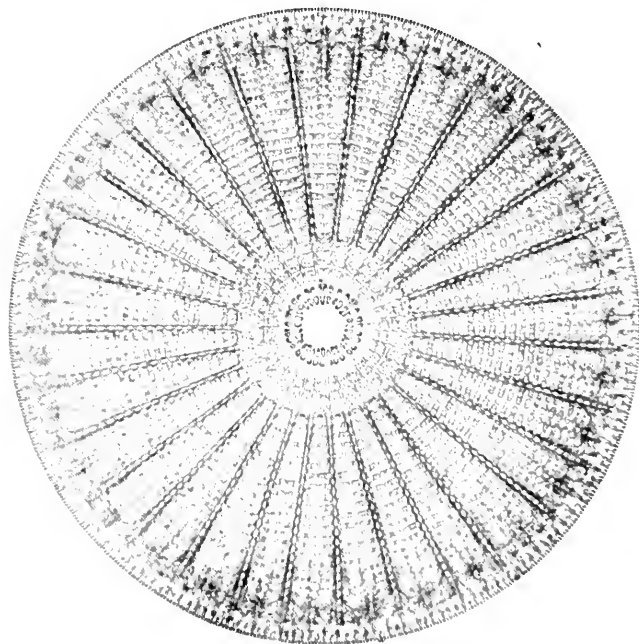

ARACHNODISCUS EHRENBURGII. (X 320 DIA.)
ZEISS APOCHROMATIC OBJECTIVE 16 MM. AND COMPENSATION EYEPiece 18.

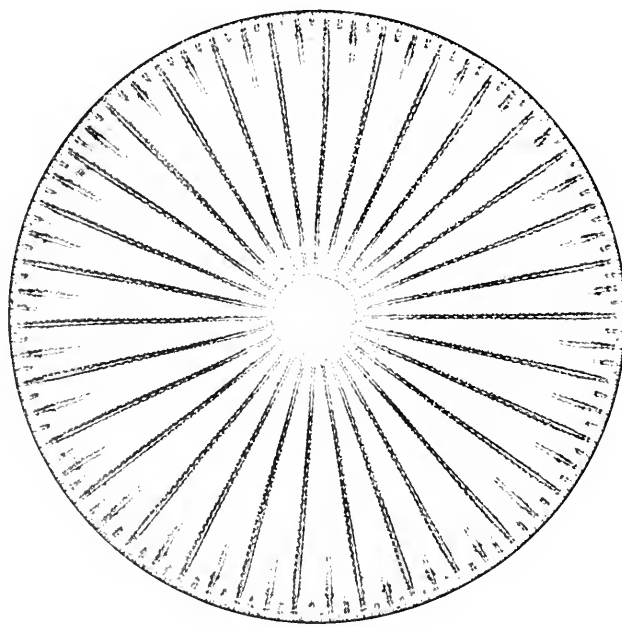

ARACHNODISCUS EHRENBURGII. (X 320 DIA.)
ZEISS APOCHROMATIC OBJECTIVE 4 MM. AND COMPENSATION EYEPiece 4.

LENSES: THEIR CONSTRUCTION AND USE.

INTRODUCTION.

THE lens has been called the eye of the camera, and is undoubtedly the most important part of the photographer's outfit. On the quality and perfection of the

sure the best results from lenses, even from good ones, it is necessary to have some knowledge of the laws which operate in their construction and manipulation. Such information, conveyed as far as

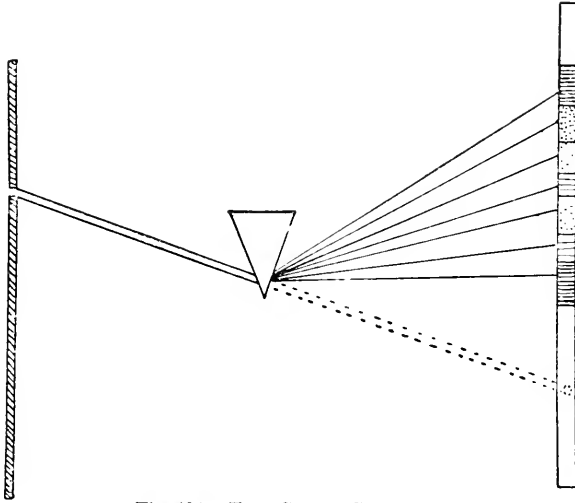

Fig. 484.—THE SOLAR SPECTRUM.

lens employed depend the detail and accuracy of the image thrown on the sensitive plate. It is true that good pictures may be obtained with comparatively inexpensive lenses, but there is no doubt that even better results would have been secured with objectives of higher quality. For landscape or pictorial work the difference may not be serious, but for more exact and delicate operations the contrast will be very pronounced. The photographer is therefore advised to pay particular attention to the quality and finish of his lenses. But in order to en-

possible in language free from technicalities, is given in this section.

NATURE AND PROPERTIES OF LIGHT.

The commonly accepted theory with regard to light is that it consists of a regular series of extremely rapid undulatory waves, the substance in motion being the ether which is said to pervade all space. Light is not matter, but motion. In precisely the same way as ripples in a pond, started by throwing a stone, will multiply and spread outward in wave like

formation, so a succession of amazingly rapid undulations in the ether give rise to the phenomenon or sensation called light. The effect known as white light is explained as being produced by the combination of a number of rays of different wave-lengths, all acting in concert on the retina of the eye. White light may be separated into its component parts by means of a prism, when it forms a narrow band of seven distinct colours, known as the solar spectrum (see Fig. 484). The elementary colours so obtained occur in the following order: Violet, indigo, blue, green, yellow, orange, and

First come very long waves, invisible, but of distinct heating power. Next come the slightly shorter waves which produce the sensation of red: these also give out a certain amount of heat. Then come the yellow rays, still shorter, with little chemical or heating influence, but producing great visual effect, being, in fact, the brightest waves of the spectrum. The green, blue, and violet rays, together with the still shorter and invisible ultra violet, are those which act principally on the photographic plate, being consequently known as actinic. There is no reason to believe that there is any real difference in the various rays, beyond that of their varying wave-lengths. They simply act differently on certain senses.

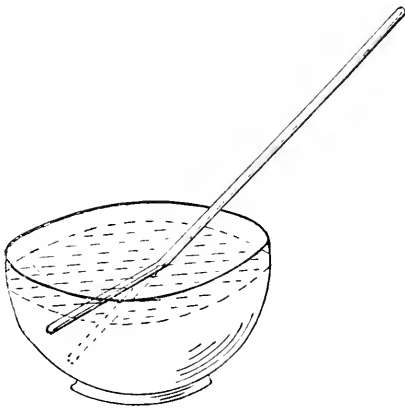

Fig. 485—REFRACTION.

red. Besides the rays which are visible to the eye, there are others which, although invisible, have high chemical or caloric activity. It should be stated that although Sir Isaac Newton regarded the above seven colours as primary, or pure, the tendency of later investigators is to recognise only six primary colours—violet, blue, green, yellow, orange, and red.

DIFFERENT WAVE-LENGTHS OF VARIOUS COLOURS.

It has been found that each colour has a different wave-length and rate of vibration, white light consisting of an ascending series of vibrations, each of its components having a shorter wave-length than the last, but all travelling together with infinite rapidity and uniformity.

REFRACTION AND DISPERSION.

It has been mentioned that light, generally speaking, travels in a straight line: there are, however, exceptions to this rule. When a ray of light passes from one medium into another of greater density, at any angle not a right angle, it is bent or refracted at a more or less acute angle, according to what is known as the index of refraction of the medium into which it enters—that is to say, its greater or lesser density. This phenomenon may be readily observed by thrusting a straight stick into a bowl of water; the stick will appear to be bent, as in Fig. 485. When white light is passed through a prism, as before described, it not only undergoes refraction, but also what is known as dispersion—that is, its component rays are caused to separate and diverge from each other. Now, in making photographic lenses, it has to be borne in mind that different kinds of glass, besides having different refractive indices, have also varying powers of dispersion—a fact which proves very useful to the optician, as will be shortly seen.

VISUAL AND CHEMICAL FOCI.

If we examine the solar spectrum obtained by the passage of a ray of sunlight through a prism, it will be seen that the different-coloured rays are not equally

refracted: the violet and blue are refracted most, and the red least. As a consequence, with an uncorrected lens, the blue and violet rays are brought to a focus in the camera further away from the ground-glass screen than the orange, yellow, and green rays. Now these latter, as previously mentioned, produce the most effect on the eyes, the blue and violet rays, although the most actinic, giving a comparatively feeble illumination. The result is that focussing is effected principally by the aid of the brightest but least actinic rays, so that when the image is in focus to the eye, the green, yellow, and orange rays are chemically in focus, but the violet and blue rays are not (see Fig. 486). Here it will be noticed that, after passing through the lens, the red rays, R, are brought to a focus in front of the violet rays V, the blue, green, yellow, and orange rays being focussed at intermediate positions.

CHROMATIC ABERRATION.

The effect of this is that on development the plate will give a blurred image, although the picture may appear to be perfectly sharp on the focussing screen. This defect of a simple lens is known as chromatic aberration, and calls urgently for correction. Fortunately, the dispersive power of glass varies in different kinds, according to the ingredients which enter into their composition. The refractive and dispersive powers of any kind of glass are not necessarily connected by any kind of ratio: two specimens of glass may have the same index of refraction but a widely different dispersion, or the opposite. Crown and flint glass, having different densities, vary in their refractive and dispersive powers; and it is found that by placing a concave lens of flint glass behind a convex lens of crown glass, as in Figs. 487 and 488, chromatic aberration may be satisfactorily corrected. Sometimes three or more lenses may be used in combination, the principle, however, being the same. A lens corrected in this manner is known as achromatic, or colourless.

CORRECTION FOR NON-ACHROMATIC LENSES.

Non-achromatic or uncorrected lenses, also known as spectacle lenses, are frequently used by photographers for landscapes and for experimental purposes; in the first case, on account of a pleasing

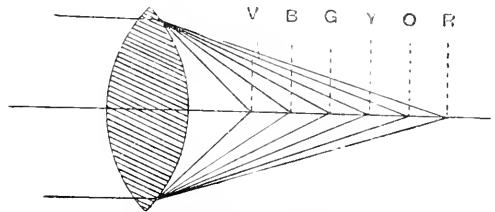

Fig. 486.—CHROMATIC ABERRATION.

breadth and diffusion of focus obtained by their use, and in the second because of their cheapness. The amount of chromatic aberration may be readily allowed for in this way: Focus in the ordinary manner; then, before exposing,



Fig. 487.



Fig. 488.

Figs 487 and 488.—CROWN AND FLINT GLASS TO CORRECT CHROMATIC ABERRATION.

decrease the distance between the lens and plate by $\frac{1}{10}$ th of the focal length of the lens. For example, if the lens is of 10 in. focus, rack in the bellows for $\frac{1}{10}$ in.; the resulting negative will then be in focus. This only applies to landscape photography, or objects at a distance; for portraiture, copying, and other close work a greater correction will be necessary. The amount can be ascertained by experiment, first carefully focussing, then inserting a plate and exposing portions only of this at various distances from the lens, by masking different parts of the plate and gradually racking in the bellows after each exposure. The plate is then

developed, and the sharpest portion ascertained. By comparing the visual focus with the distance thus obtained, the necessary correction is at once known. Another method is to place a cobalt blue glass in front of the lens while focussing, removing it for the exposure; the chemical and visual focus will then coincide. The same result is secured by focussing through an isochromatic screen, providing the exposure is made with the screen.

SPHERICAL ABERRATION.

Spherical aberration is due to the curved surface of the lens, and may be defined as the inability of the lens to bring the rays which pass through its edges or margin to the same focus as those passing through its centre (see Fig.

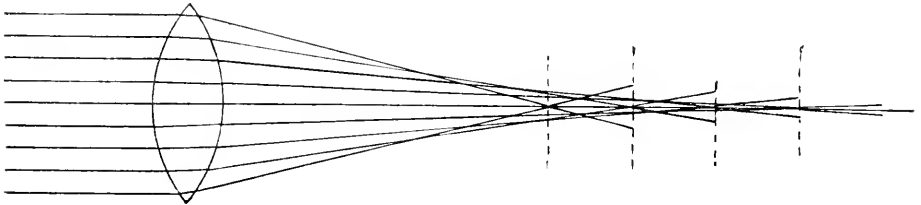

Fig. 489.—SPHERICAL ABERRATION.

489). The effect of this, if uncorrected, would be that, no matter how the focussing screen was placed, each point in the image would be depicted by a nebulous disc, and these would all overlap each other, making it impossible to secure a sharp picture. The lens, in fact, would have no absolute focus, but rather a number of different and clashing foci. All single lenses are subject to this form of aberration, and will not give a sharp image unless stopped down, so that only the centre is used and the marginal rays cut off. There are two descriptions of spherical aberration, known as negative and positive, the amount and quality being governed by the curve or curves of the lens. Convex lenses cause positive aberration, and concave lenses give rise to the negative form, so that, by combining different lenses of suitable curvature, spherical aberration may be practically

eliminated, although with spherical lenses it can never be entirely removed. For practical purposes, it is considered sufficient when the image of a point of light is rendered in the picture as a circle of not more than $\frac{1}{1000}$ th of an inch in diameter. In high-grade lenses an even greater degree of correction is secured.

COMA.

There is yet another defect to which lenses may be subject, even when perfectly corrected for both chromatic and ordinary spherical aberration. This is known as zonal aberration, and results from the various zones of the lens being of different power, so that they produce unequal magnification. As a consequence, the image of a bright point of light towards the

margin of the field of view will be distorted into a pear-shaped or comma-shaped blur—a phenomenon appropriately designated *coma*. Zonal aberration is often referred to as oblique spherical aberration. It is corrected by very careful choice and designing of the optical constituents and curves of the lens.

ASTIGMATISM.

Astigmatism, sometimes known as stigmatic aberration, is present in a greater or less degree, in all the cheaper kinds of lenses, and may be defined as the effect caused by the lens bringing oblique rays of light to two focal lines instead of to a single focal point. The result is that it is impossible to get both horizontal and vertical lines sharp at the same time. If this error is present to any extent, it is a great hindrance to architectural

photography, or any work requiring fine definition and accurate rendering of straight lines. The effect produced by a lens uncorrected for astigmatism is well illustrated by Fig. 490, which is a photograph of a series of concentric rings. The blurring shown at the sides is pronounced. Astigmatism generally makes itself visible towards the margins of the field, where it may seriously affect the definition. It may be remedied to a great extent by the use of a small stop, but is corrected in high-class lenses by carefully designed arrangement of the curves and thicknesses of their components. A lens so corrected is known

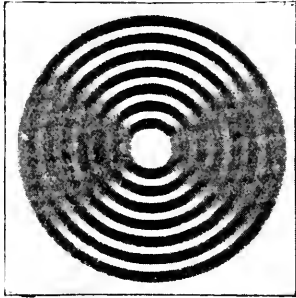

Fig. 490.—EFFECT PRODUCED BY ASTIGMATISM.

as an anastigmat or orthostigmat. Astigmatism, although seldom entirely absent from any lens, is more usually found in lenses designed to obtain great flatness of field. The introduction of Jena glass has enabled the optician to devise combinations in which this defect is almost entirely eliminated. The method of testing for astigmatism is described on p. 35.

CURVATURE OF FIELD.

One difficulty inseparable from the spherical form in which lenses are ground has already been dealt with, namely, spherical aberration. There is, however, another. The image of a flat object is not formed on a plane or flat surface, but on a curved one; thus it follows that if the middle of the picture is focussed for with full aperture, the edges are out of focus, and *vice versa*. This fault is known

as curvature of field. In the example shown in Fig. 491, A represents a lens uncorrected for curvature of field, D the diaphragm, o the object, and $f f$ the plane of the image. It is evident that if $h h$ be the position of the focussing screen,

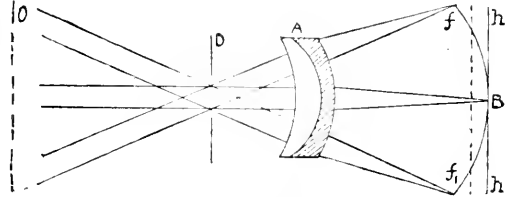

Fig. 491.—CURVATURE OF FIELD.

the only portion of the image in focus will be the central part B. Obviously, the best effect, in the circumstances, will be obtained by placing the screen midway between the extremes of focus, as shown by the dotted line, and using the smallest stop possible. Curvature of field is sometimes due to faulty adjustment of the lens, in which case matters may often be improved by slightly altering the degree of separation between the com-

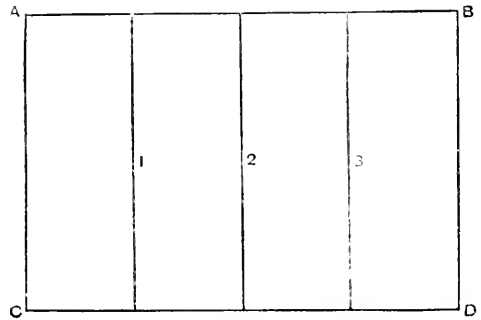

Fig. 492.—METHOD OF OVERCOMING CURVATURE OF FIELD.

binations. The best modern high-grade lenses have an almost perfectly flat field. The most satisfactory method of overcoming curvature, where it is known to be present in the lens, is shown by Fig. 492. Let A B C D represent the focussing screen. Divide this with ruled pencil lines, or mentally, into four equal divisions, using the longest side of the screen if it is rectangular. As will be

evident, by comparison with Fig. 491, the figure 2, being in the centre, will fall in one extreme of the focus, while the outside edges of the plate represent the other extreme. If, then, focussing is done on any object falling on the intermediate figures 1 and 3, the mean between the two extremes is obtained, which will give the most satisfactory result, provided the lens is well stopped down.

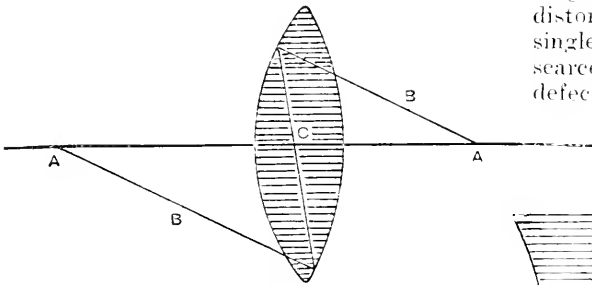

Fig. 493.—OPTICAL CENTRE OF DOUBLE CONVEX LENS.

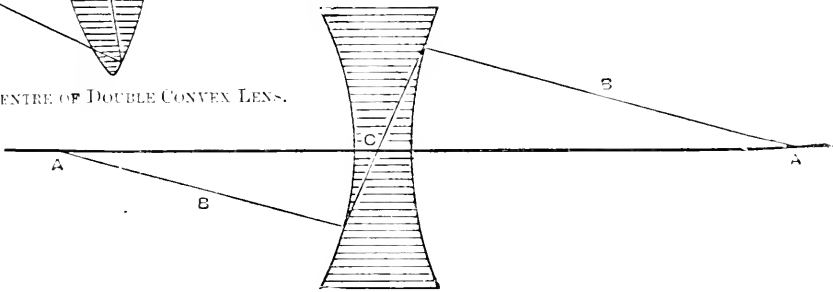

Fig. 494.—OPTICAL CENTRE OF DOUBLE CONCAVE LENS.

DISTORTION.

All single lenses, whether composed of one glass only or of several cemented together, possess a certain amount of distortion—that is, a disposition to reproduce straight lines near the margin of the picture as curved lines. This, of course, is a great obstacle to the use of such lenses for architectural or similar subjects. As explained on p. 28, the distortion may be either of two kinds, known as "barrel" and "pin-cushion" distortion, according to the position of the diaphragm before or behind the lens. The greater the distance between the diaphragm and the lens, the better the definition, but the distortion will be increased. On the other hand, the nearer the diaphragm approaches the lens, less distortion but poorer definition will result. The method of ascertaining the best

position for the diaphragm is explained on p. 35. In rectilinear and symmetrical lenses distortion is counteracted by placing the diaphragm between two combinations, when one kind of distortion balances the other, and both are obliterated. The barrel form of distortion is generally considered the least objectionable, therefore nearly all single lenses are fitted with the diaphragm in front. The longer the focus of the lens the less the distortion that occurs; a good quality single lens of long focus will show scarcely any appreciable amount of this defect. It is not generally known that

distortion in a negative may be corrected by enlarging, if the same lens is used for making the enlargement.

OPTICAL CENTRE OF A LENS.

The optical centre of a lens is that point at which the lines forming the image cross each other, the focal length of the lens being always measured from the optical centre to the ground surface of the focussing screen. A lens may be rotated or swung round upon its optical centre without shifting the image on the ground glass: a fact which has been turned to advantage in various forms of panoramic cameras. To ascertain the optical centre of a lens, draw from the centres of the curved surfaces A A (Fig. 493) two radii B B parallel to each other, and join their extremities, producing them if necessary.

The line so obtained will cut the axis of the lens at a certain point *c*, which is the required optical centre.

OPTICAL CENTRE OF VARIOUS SIMPLE LENSES.

It has been seen that the optical centre of a double convex lens is within the glass. Fig. 494, in which the same lettering is adopted as before, shows that this

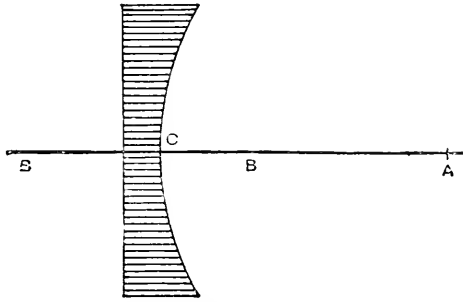

Fig. 495.—OPTICAL CENTRE OF PLANO-CONCAVE LENS.

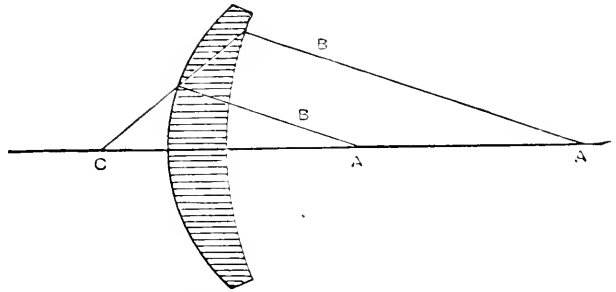

Fig. 497.—OPTICAL CENTRE OF MENISCUS LENS.

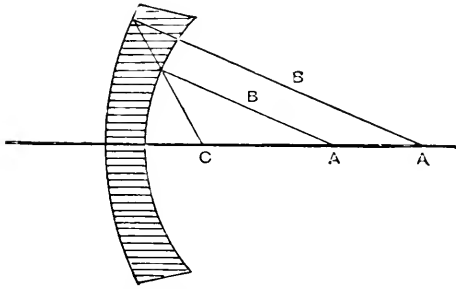

Fig. 496.—OPTICAL CENTRE OF CONCAVO-CONVEX LENS.

is also the case with a double concave lens. With plano-concave and plano-convex lenses it is impossible to draw the parallel radii, since there is only one curve. The optical centre is therefore, as a little consideration will show, on the curved surface of the lens, where it is cut by the axis (see Fig. 495). A concavo-convex lens has its optical centre outside and in front, as in Fig. 496; whilst a meniscus lens has its centre outside and behind (Fig. 497). It will be seen that it is an easy matter to calculate the optical centre

of any simple lens: with compound lenses, however, the matter becomes more complicated.

OPTICAL CENTRE OF COMPOUND LENSES.

In doublet lenses of rectilinear construction, and also in most symmetrical combinations, the optical centre of the lens is situated practically at the diaphragm, and measurements from the latter to the ground glass will give a sufficiently accurate estimate of the equivalent focus for all ordinary purposes. In other forms of compound lenses which are not symmetrical, the optical centre may vary considerably in position, being either in front of or behind the diaphragm. Fortunately, although it is difficult to ar-

rive at the position of the optical centre by calculation in such cases, there is a practical method available of great simplicity. This consists of focussing the lens being tested on a distant object, and selecting a thin spectacle lens which will give an image of precisely the same size from the same standpoint. This is readily done by the optician, who usually keeps a large number of different kinds of spectacle lenses at hand for testing purposes. If, then the distance is measured from the edge of the spectacle lens, which is found to give an image of the desired size, to the ground glass, this will be equal to the equivalent focus of the compound lens under examination, and it is easy to mark the optical centre of the latter on the lens mount. As a matter of fact, every compound lens has two optical centres, also called equivalent

or nodal planes, according to the direction in which the lens is turned. Most lenses, however, are only intended to be used one way round, and it is only necessary to ascertain the optical centre of the objective when pointed in that direction.

PRINCIPAL OR EQUIVALENT FOCUS OF A LENS.

The principal or equivalent focus of a lens, also known as the focal length, may be defined as the distance between the optical centre of the lens and the ground glass, when focussed on an object at great distance. Various methods of finding the approximate focal length of a lens have already been given (see p. 34), but where greater accuracy is desired the following plan may be pursued. Focus on a distant object, such as a church spire, and mark the position occupied by the lens front on the baseboard of the camera. Now set up any object of known length, such as a foot-rule, focus, and again mark the place occupied by the lens front. Expose a plate, develop, and carefully ascertain the measurement of the foot-rule or other object in the negative. Measure the distance between the two marks on the baseboard, multiply this distance of difference by the length of the object photographed, and divide by the length of the object in the negative. The result will give the focal length or equivalent focus of the lens. Another method, available when the optical centre of the lens is known, is to point the camera at the sun and focus on this. When the image of the sun is sharp on the ground glass, the distance between the latter and the optical centre of the lens gives the equivalent focus.

BACK FOCUS.

The back focus of a lens is simply the distance between its back surface and the focussing screen. At one time, lenses were often referred to by their back focus, or, in other words, the length of camera extension required with them, which was sufficiently accurate with the simple objectives then in use. The more

complex lenses of to-day have, however, rendered this method of classification of little value, as it is found that the back focus has no practical relation to the size of the image obtainable—which, as previously explained, depends on the equivalent focus alone.

CONJUGATE FOCI.

The principal or equivalent focus of a lens, as before stated, is obtained by focussing on an object at a great distance. If, however, objects which are nearer to the camera are focussed for, the focal length becomes greater, and the bellows will require racking further out. The object can be brought still nearer, and the bellows racked out more, until the focal length is exactly double that of the equivalent focus. When this is the case, it will be found that the object on the screen is the same size as the original, and the distances between the object and lens and the lens and ground glass are equal. The distances of an object from the lens, and of the lens from the image, are known as conjugate foci, and always bear a definite relation to each other. If one focus is lengthened the other will be shortened, and vice versa; the positions of the object and the focussing screen may also be transposed, when both will still be in focus, but the size of the image will be altered. This latter fact is made use of in enlarging and reducing.

CALCULATION OF CONJUGATE FOCI.

Let a = the distance of object from lens, b = distance of focussing screen or image from lens, and f = focal length or equivalent focus of lens.

$$\text{Then } \frac{1}{f} = \frac{1}{a} + \frac{1}{b}, \text{ or } f(a + b) = ab.$$

If the image of an object is x times smaller than the original on the focussing screen, a is $x + 1$ times the focal length of the lens, and b is equal to the focal length $+ \frac{1}{x}$ of the focal length. For example, if the image of a yard measure is 3 in. long on the focussing screen, with a lens of 12 in. focus, $a = 13 \times 12 =$

156 in., and $b = 12 + \frac{1}{12} = 13$ in. This rule may obviously be employed for enlarging, reducing, and copying, by simply transposing the terms. Thus, the above instance will give the necessary distances for easel and negative, to enlarge 12 times, if for focussing screen is read negative, and for object, easel. To make this clearer, the rule for enlarging may be given. To find the distance from the negative to the lens, divide the focal

and amount of spherical aberration present. The shorter the focal length, the greater the depth of definition, which also increases as the aperture diminishes. A small amount of spherical aberration is occasionally advisable, since it increases the depth of focus; it must, however, be very slight in extent. Curiously enough, the finer the lens, and the more highly corrected it is, the greater care must be taken in focussing.

DIAPHRAGM APERTURES.

FOCUS OF LENS IN INCHES.	NUMBER OF FEET AFTER WHICH ALL IS IN FOCUS.													
	f 7	f 8	f 9	f 10	f 11	f 12	f 13	f 14	f 15	f 16	f 17	f 18	f 19	f 20
4	19	17	15	14	13	12	11	10	9	9	8	8	7	7
4½	21	19	17	15	14	12	11	11	10	10	9	9	8	7
4¾	25	22	19	17	16	15	13	13	12	11	10	10	9	9
4⅝	27	23	21	19	18	16	15	14	13	12	12	11	10	10
5	30	27	24	21	19	18	17	15	14	14	13	12	11	10
5¼	33	29	25	23	21	20	18	17	16	15	14	13	13	12
5½	37	31	29	26	23	22	20	19	17	16	15	15	14	13
5¾	39	34	31	28	26	24	22	20	18	18	17	16	15	14
6	43	38	33	31	28	26	24	22	21	20	18	17	16	15
6¼	47	41	37	33	30	28	26	24	22	20	20	19	18	17
6½	50	45	40	36	33	29	28	26	24	23	21	20	19	18
6¾	55	48	43	39	36	32	30	28	25	24	22	22	21	20
7	58	52	45	42	38	35	31	30	28	26	25	23	22	21

TABLE OF DEPTH OF FOCUS.

length by the number of times of enlargement, and add the focal length. For example, with an 8 in. lens, and enlarging 4 times, the required distance would be $\frac{8}{4} + 8 = 10$ in. To find the distance from the lens to the paper, multiply the focal length by the number of times of enlargement, and add the focal length, which, in this case, would mean $(8 \times 4) + 8 = 40$ in.

DEPTH OF FOCUS.

Depth of focus is the extent to which a lens is capable of rendering objects in different planes sharply on the ground glass screen at the same time; this is sometimes called the definition of the lens. The depth of focus in a lens is governed by the focal length, aperture,

PHOTOGRAPHIC DEFINITION.

The ideal definition of the optician, in which points contained in the object shall be represented as geometrically points on the screen, is practically unattainable, although what is known as microscopic definition is successfully achieved in lenses for use in astronomical work and as microscope objectives. Modern anastigmats of high quality also possess this property. Photographic definition, as a consideration of what has been said with regard to depth of focus will readily show, belongs to a different category. For microscopic or astronomical work the objects are, practically speaking, in one plane, or confined to the centre of the field. In ordinary photography, however, objects in different planes and spread over a large area have to be all brought

together on the screen with approximately the same amount of definition. Therefore, a certain sacrifice of critical sharpness has to be made, and a certain amount of what is called diffusion of focus introduced, in order that a fair average may be struck and the best effect secured.

TABLE OF DEPTH OF FOCUS.

The preceding table, compiled by Sir D. Salomon, showing the distance at and beyond which all objects are in focus, with different lenses, will probably prove of service to those who have fixed focus hand cameras.

THE EVOLUTION OF THE LENS.

The lens employed by Baptista Porta for his camera obscura was a plano-

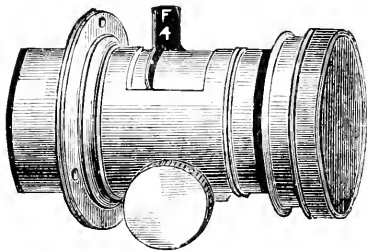

Fig. 198.—PETZVAL PORTRAIT LENS.

convex, the convex side being nearest the image. In the cameras used by Daguerre, which were made by Charles Chevalier, of Paris, the lens was placed the other way round, its flat side facing the focusing screen. This was found to give better clearness and definition, but less covering power; and diaphragms or stops were introduced to remedy this defect. A further improvement, by Andrew Ross, consisted of changing the plane surface of the lens into a concave one, forming thereby a meniscus lens. The same optician is given the credit of first solving the problem of how to avoid linear distortion, which he achieved by combining two plano-convex lenses separated by a diaphragm. Thomas Ross, a son of Andrew Ross, improved on this by the substitution of a pair of meniscus glasses.

INTRODUCTION OF THE PETZVAL LENS.

In 1841 J. Petzval, a mathematician of Vienna, designed two objectives which were constructed by F. Voigtländer from drawings supplied by the designer. One of these, the well-known Petzval portrait lens, was characterised by large aperture and shortness of focus, having consequently great rapidity; the other was of longer focus, and was known as the orthoscopic lens. The attention of Petzval had been drawn to the fact that the lenses used by Daguerre required a small diaphragm, which necessitated a lengthened exposure; and the two lenses he introduced were the result of much study and research, pursued with the object of obviating this inconvenience. As will be seen by Fig. 43 (p. 32), the portrait lens consists of a front combination formed by a bi-convex lens of crown glass cemented to a plano-convex lens of flint glass. The back combination is composed of two separated lenses—namely, a concavo-convex of flint glass and a bi-convex of crown glass. Its characteristic external appearance is shown by Fig. 198.

JENA GLASS.

One of the chief factors contributing to the progress made in the manufacture of modern lenses has been the introduction of what is known as Jena glass. As early as 1812, Grimaud, a French glass manufacturer, made glass with borates instead of silicates, but failed to find any demand for the new substance. Later on, however, Schott & Co., of Jena, succeeded in establishing an extensive industry, opticians having discovered the valuable improvements in lens construction rendered possible by the varying refractive and dispersive powers of the different kinds of glass. English and French firms soon followed suit, and glasses of previously unknown properties are now obtained by the addition of aluminium, antimony, boron, magnesium, phosphorus, and other substances, each ingredient producing its own peculiar variation in the optical possibilities of the resulting glass, almost any desired modification being procurable.

IMPROVEMENTS IN MODERN LENSES.

The rapid rectilinear lens is, perhaps, the most widely used of all types. It was introduced simultaneously in England and Germany by Dallmeyer and Steinheil respectively, the latter giving it the name of Aplanat. From that time one improvement followed another, till with the anastigmat of to-day it would almost appear that the limit of perfection has been reached. The anastigmat, first made in this country by J. H. Dallmeyer and H. D. Taylor, is more highly corrected for astigmatism and oblique aberrations than the rectilinear, gives better definition, more even illumination, and greater rapidity. The apochromatic lens, corrected for three colours of the spectrum instead of merely two, as in most lenses, is another notable advance, and has rendered great service in three-colour photography. The telephoto lens, by which objects may be photographed at a great distance, is also a valuable acquisition of comparatively recent date.

THE FIRST ANASTIGMAT.

Dr. A. Miethe was one of the first to realise the advantages of the new glasses, and in 1888, Hartnack, of Potsdam, was supplied by him with the formulæ for a lens in which astigmatism was almost eliminated, and which gave a flat field and fine definition with a large aperture. In the same year, the Concentric lens was patented, so named from the fact that the radii of all the curves were struck from a common centre. This lens was of the symmetrical type, and possessed great covering power and flatness of field, with complete freedom from astigmatism: it worked, however, at a comparatively small aperture. About 1892, Messrs. Zeiss introduced a series of lenses from calculations supplied by Dr. P. Rudolph, of Jena, which embodied the principle of two triple combinations forming distinct systems of cemented glasses, and possessing opposite degrees of refractiveness. By this means it became possible to obtain perfect correction for astigmatic, spherical, and

chromatic aberrations, combined with flatness of field and a large aperture. This was a great advance, flatness of field having previously only been possible at the expense of a certain amount of astigmatism. The credit of first using triple cemented combinations for correcting astigmatism and spherical aberration has also been claimed on behalf of Herr Von Hoegh, who appears to have been working simultaneously with Dr. Rudolph, in much the same direction, the result of his labours being the celebrated Goerz double anastigmat (Fig. 514).

CLASSIFICATION OF LENSES.

Lenses, with the exception of those intended for special purposes, which are generally modifications of one type or other, may be roughly divided into six groups. These are: the single non-achro-



Fig. 499.—SECTION OF SINGLE NON-ACHROMATIC LENS.

matic, or spectacle lens; the double meniscus, or periscopic; the single achromatic; the Petzval portrait; the rapid rectilinear; the anastigmat. The various types of wide-angle lenses are classed with the rapid rectilinear; while the anastigmats may be divided into two descriptions, the unsymmetrical and the universal. Many lenses are given special patent or trade names to distinguish them from other makes, but they may all be identified, without much difficulty, with one or other of the above groups. Of course, it by no means follows that because a lens may have similar working properties it is therefore constructed in the same manner. Two lenses giving identical results may be designed on a totally different principle. It must be remembered, therefore, that any attempt at classification in lenses can only be done roughly, and in an arbitrary fashion.

THE SINGLE NON-ACHROMATIC LENS.

The single non-achromatic or spectacle lens (Fig. 499) is sometimes used by pictorial workers who admire fuzziness and impressionism. It is only placed deliberately on extremely cheap cameras, where it is helped out by a small stop.



Fig. 500.—SECTION OF DOUBLE MENISCUS LENS.

Since it is uncorrected for chromatic aberration, it is no use focussing with it in the ordinary way; the result must be corrected by one of the methods described on p. 355. Besides this fault, the lens is subject to spherical aberration, curvature of field, and astigmatism, unless well stopped down. Except when used as a supplementary lens, or magnifier, to alter

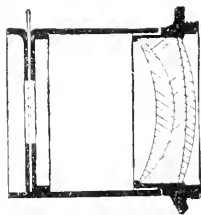

Fig. 502.—SECTION OF THREE-GLASS SINGLE ACHROMATIC LENS.

the focus of another, it is hardly adapted for practical work of any description.

THE DOUBLE MENISCUS LENS.

The double meniscus or periscopic lens (Fig. 500) is also non-achromatic, and cannot be used for direct focussing. It is fairly satisfactory in fixed focus hand-cameras, or with a carefully adjusted focussing scale, specially marked to allow for correction, and has the advantage over the single lens that it gives hardly any

distortion, and may be used with a larger aperture; astigmatism and spherical aberration are also better corrected, though still present to an appreciable extent. It is certainly not a lens to be adopted by the serious worker, if a better is obtainable. It does not seem to be

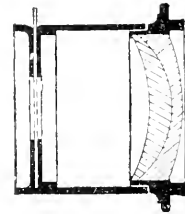

Fig. 501.—SECTION OF TWO-GLASS SINGLE ACHROMATIC LENS.

generally known that a long exposure cannot be safely given with any lens uncorrected for colour, since, even when the focus has been properly adjusted to allow for this, the other rays which are not brought to a focus have sufficient time to act on the plate, and, of course, have the effect of slightly blurring the image.

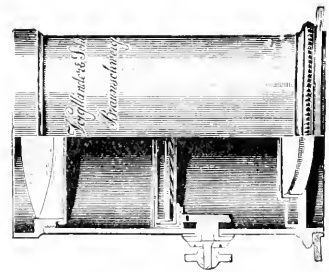

Fig. 503.—VOIGTLÄNDER PORTRAIT LENS.

THE SINGLE ACHROMATIC LENS.

The single achromatic lens (Figs. 501 and 502) is always made of two, three, or even four parts cemented together, and is commonly of a meniscus form. The stop is generally placed in front, this being found to be the best position. These lenses are admirably adapted for landscape work, on which account they are often known as landscape or view lenses; having only two reflecting surfaces, they give remarkably brilliant images. The

triple form (Fig. 502), now seldom met with, was at one time a favourite on account of its large angle of view; but it was found to give an undesirable amount of distortion, and consequently fell into disuse. The single achromatic lens is commonly fitted to the less ex-

types of lenses intended for portraiture. There is a growing tendency to prefer certain modifications of the rectilinear and anastigmatic type to the Petzval, on account of their softer definition and greater depth of focus. A valuable feature in some of the modern portrait lenses is

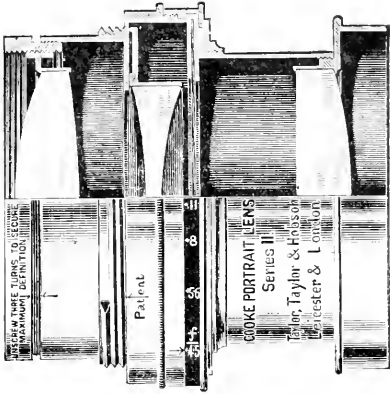

Fig. 504.—COOKE PORTRAIT LENS.

pensive hand cameras, and, as its name indicates, is properly corrected for colour, thus allowing focussing in the ordinary manner. Its principal drawbacks, for all-round work, are its distortion and the fact that it is not well adapted for use

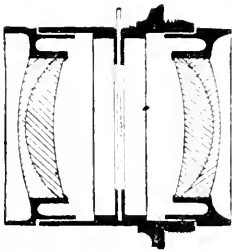

Fig. 505.—SECTION OF RAPID RECTILINEAR LENS.

with a larger aperture than f 11. In some of the better-class lenses of this description, however, distortion is so minimised as to be scarcely noticeable.

PORTRAIT LENSES.

The Petzval portrait lens has already been described (see p. 362); mention, therefore, need only be made here of other

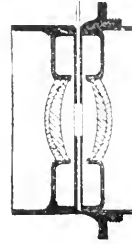

Fig. 506.—SECTION OF WIDE-ANGLE RECTILINEAR LENS

that, by a screw arrangement for slightly increasing the separation between the combinations, the amount of diffusion of focus may be altered at will; so that the photographer may secure either critical sharpness in one plane only or a more diffused definition over several planes. Lenses are also now made to work at much larger apertures than was at one



Fig. 507.—DALLMEYER WIDE-ANGLE RECTILINEAR LENS.

time considered possible; as, for instance, in the portrait lens of Voigtlander (Fig. 503), which works at f 2.3. The Cooke portrait lens (Fig. 504) consists of three simple glasses only, and, as will be seen, allows of adjustment between its components, to secure different effects. The Dallmeyer-Bergheim lens is a favourite with workers of the impressionist school. It consists of two uncorrected single

lenses, of negative and positive curvature respectively, and introduces a pleasing amount of diffusion of focus. The separation is adjustable, so that the focal length may be varied.



Fig. 508.—BECK FOCUSSED BIPLANAT.

RAPID RECTILINEAR LENSES.

The rapid rectilinear group includes, besides the various objectives of that name, those known as rapid symmetrical, euryscope, aplanat, biplanat, periplanat,

linear. The Dallmeyer wide-angle rectilinear, which works at the comparatively large aperture of f 16, is shown by Fig. 507. A rectilinear of large aperture, say f 4 or f 3.8, is admirably adapted for portraiture; such a lens is known as an extra-rapid rectilinear if working at f 4,

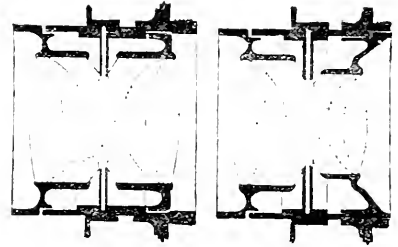

FIG. 509. FIG. 511.

Figs. 509 and 511.—BECK-STEINHEIL ORTHOSTIGMATS.

or a biplanat if at f 5.8. The Beck Biplanat, an excellent objective of this kind, which has a movable graduated ring on the mount, allowing focussing to be done without consulting the ground glass, is illustrated by Fig. 508. The rectilinear type of lens would almost represent perfection for all ordinary work if it were

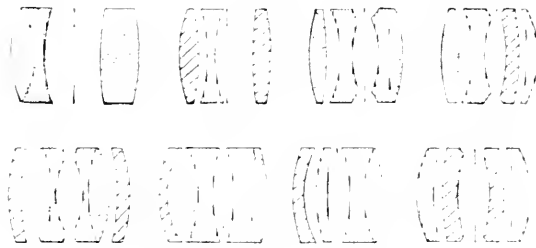

Fig. 509 —UN-SYMMETRICAL ANASTIGMATS.

and other distinctive titles, besides the wide-angle variety. The usual form of rapid rectilinear (Fig. 505) is symmetrical, consisting of two similar combinations, with the diaphragm between. As its name indicates, it overcomes distortion, and gives also a large aperture combined with flatness of field. The wide-angle rectilinear (Fig. 506) has a smaller aperture, and the combinations are placed closer together, being, it will be noticed, also larger in proportion to the size of the aperture than those of the ordinary recti-



Fig. 512 —SINGLE COMBINATION OF ORTHOSTIGMAT USED SEPARATELY.

not for the presence of a certain amount of astigmatism and oblique spherical aberration, which renders it necessary to stop the lens down in order to secure equal definition to the full limits of the angle of view. If of good make, however, it will be found quite equal to the requirements of the average photographer.

ANASTIGMATIC LENSES.

The group of anastigmats may be roughly divided into two classes, the

unsymmetrical and the symmetrical, the latter being often described as the universal. Some of the various combinations employed in different patterns of unsymmetrical anastigmats are

mat is symmetrical, or nearly so, and its combinations can be used separately. It is even more perfectly corrected than the unsymmetrical anastigmat, and, as its name indicates, may be used for almost

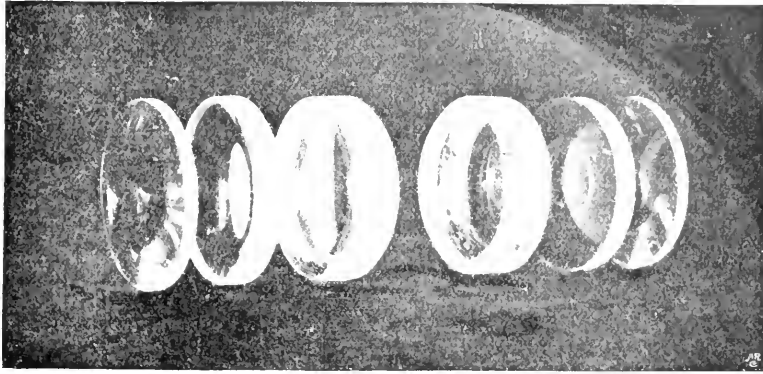

Fig. 513.—SIX COMPONENTS OF BECK-STEINHEIL ORTHOSTIGMAT.

shown in Fig. 509. As a rule, the two components of these lenses cannot be used separately, as in the rapid rectilinear type. The modern anastigmat represents the highest point of lens manufacture at

any branch of photographic work. Figs. 510 and 511 show two patterns of the Beck-Steinheil orthostigmat (anastigmat), and Fig. 512 indicates how a single combination may be used separately. The



Fig. 514.—GOERZ DOUBLE ANASTIGMAT.

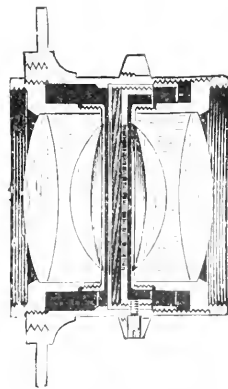

Fig. 515.—SECTION OF GOERZ DOUBLE ANASTIGMAT.

present attained. Astigmatism is practically eliminated, the other corrections being also remarkably successful. It gives high rapidity and splendid quality of definition, but, as a consequence, a certain amount of depth of focus has inevitably to be sacrificed. The universal anastigmat

is symmetrical, or nearly so, and its combinations can be used separately. It is even more perfectly corrected than the unsymmetrical anastigmat, and, as its name indicates, may be used for almost

six components of a Universal orthostigmat are shown uncemented in Fig. 513. The Goerz double anastigmat, another justly celebrated objective of the universal type, is illustrated by Figs. 514 and 515. It possesses a flat field, exquisite definition and remarkable covering power.

GROUP LENSES.

For taking groups a lens is required giving flatness of field and evenness of definition over a fairly large angle. The

traiture. Negatives produced by such lenses have the further advantage of requiring less retouching, on account of their greater softness of definition. A large aperture is more necessary with a

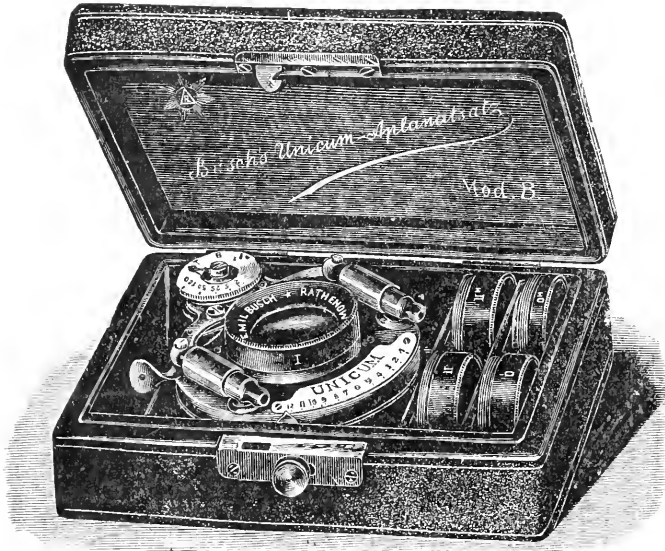

Fig 516.—SET OF COMBINATION LENSES.

old Petzval portrait lens is hardly satisfactory in this respect, although good results may be obtained when a semi-

group lens than with one intended for ordinary studio work, as will be evident when it is remembered that the risk of

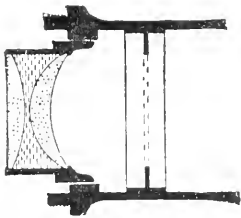

Fig. 517.—TELEPHOTO ATTACHMENT.

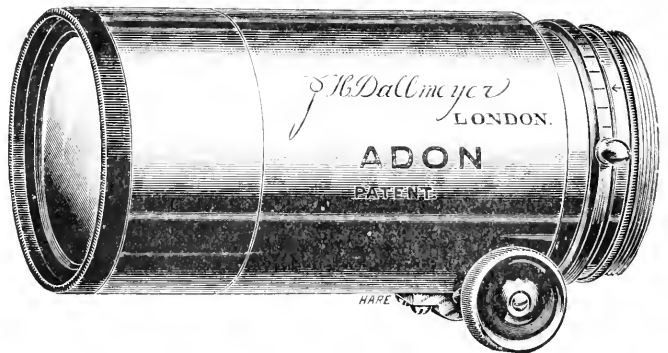

Fig. 518.—DALLMEYER'S "ADON" LENS.

circular arrangement of the sitters is adopted. An anastigmat of the universal type, or a biplanat, is preferable for this purpose, as well as for ordinary por-

movement becomes greater with every additional sitter included, and, in consequence, the exposure has to be made with all possible expedition.



RUINS. WHITBY ABBEY (NORTH SIDE)

LENSES FOR ENLARGING AND COPYING

Should possess flatness of field, freedom from distortion, and critical definition; equality of illumination is also essential. Rapidity is desirable, but not indispensable. An anastigmat is undoubtedly the

combination lenses, and the supplementary lenses known as magnifiers. The former are to be considered as part of the lens proper, when in use; while the latter are merely complementary or additional.

TELEPHOTO LENSES.

The telephoto lens is virtually a long focus objective of peculiar construction; being, in effect, an application of the principle of the telescope to photography. It consists, generally speaking, of an ordinary lens of good quality—which for this purpose is known as the positive lens—and a concave attachment called the negative lens. The latter can be removed at will, when the positive lens is available for ordinary photographic work. A typical telephoto attachment, to be used behind a positive lens, is shown by Fig. 517. The Dallmeyer "Adon" lens (Fig. 518) possesses the novel feature that it is screwed to the front of the positive lens instead of the back, thus saving the trouble of removing the latter. It is

Fig. 519.—BECK STEINHEIL TELEPHOTO LENS.

finest lens for the purpose, but a good rectilinear will be quite satisfactory, if not of too short a focus. A lens which gives distortion of any kind is quite unsuitable, unless for enlarging an already distorted negative, as described on p. 358. Equality of illumination is of great importance in copying or enlarging, or the corners of the picture will be unsatisfactory. Lenses intended for photo-mechanical or process work require particularly fine correction and superb definition, which are only perfectly attained in objectives of the anastigmat type.

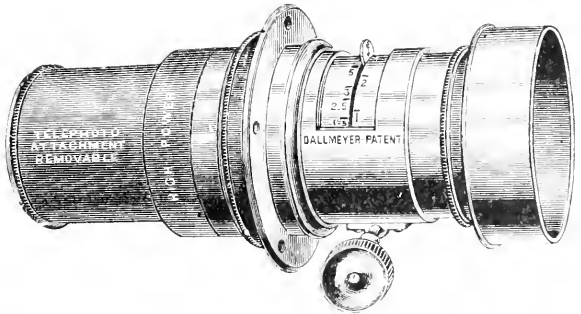

Fig. 520.—DALLMEYER'S HIGH-POWER TELEPHOTO LENS.

therefore possible to use it with hand cameras of fixed focus, it being specially designed for that purpose. The Adon can also be employed by itself, there being an arrangement for altering the separation of its components to secure any desired magnification.

SPECIAL FORMS OF TELEPHOTO LENSES.

Although a high-class telephoto attachment, used in conjunction with a good

COMBINATION AND SUPPLEMENTARY LENSES.

It is now possible to obtain convertible sets of combinations for lenses, whereby different foci may be obtained at will. A typical case of combination lenses is shown by Fig. 516. What is practically an application of the same idea is seen in the sets of "magnifiers" supplied for use with fixed focus hand cameras. These are attached in front of the lens, and enable sharply defined pictures of near objects to be obtained, so that portraiture and copying may be undertaken. Strictly speaking, there is a distinction between the various portions of a set of

ordinary photographic lens, is to be preferred, complete telephoto lenses intended only for that special purpose are obtainable. As a rule, however, these instruments are so made as to allow of the positive lens being detached and used by itself. A good example of this is shown by Fig. 519, where a telephoto attachment is fitted to a Beck-Steinheil orthostigmat. In the high-power telephoto lens of Dallmeyer (Fig. 520) a portrait lens is employed as the positive. There are various other patterns of telephoto lenses, but they are all designed on practically the same principle.

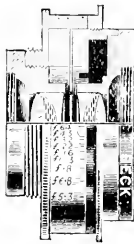

Fig. 521.—CINEMATOGRAPH LENS.

PROPERTIES OF THE TELEPHOTO LENS.

A distinctive feature of the telephoto lens is that it possesses a number of different foci instead of one focus only; that is to say, it has an adjustment for altering the focus at will. This result is achieved by altering the amount of separation between the positive and negative elements, the length of camera extension required being, of course, varied at the same time. The degree of magnification depends on the focus of the lens, and is generally indicated by an engraved scale on the mount. The depth of focus and equality of illumination often leave something to be desired, but are improved by stopping down the positive lens. Since the negative lens will magnify any defects present in the positive, it is evident that the latter must be of good quality for this class of work.

LANTERN LENSES AND CONDENSERS.

An optical lantern, or one intended for enlarging, is fitted with two compound

lenses known respectively as the condenser and the objective. The object of the condenser is to collect together the rays of light proceeding from the illuminant, and to bend them in such a manner that they all pass through the slide or negative, and are thrown through the objective. If no condenser were used, the slide would only receive a mere pencil of light, and would be unevenly illuminated. The requirements to be sought for in a condenser are that it should collect the maximum amount of light possible, that it should be free from optical defects, as well as scratches or marks likely to appear on the screen, and that it is large enough to illuminate fully the whole of the slide or negative. The objective, or projection lens, requires to have a sufficiently large aperture to receive the whole of the light from the condenser, for which reason portrait lenses are generally used for the purpose, although often possessing few recommendations but their size. An objective having greater flatness of field than the ordinary Petzval portrait lens is preferable, and it may be pointed out that if the lens opening is of sufficient diameter additional rapidity is of no advantage, since only the same amount of light will be passed with the same size of opening. For example, a 12-in. lens at $f/6$ will be quite as efficient for lantern projection as a 6-in. lens at $f/3$, although for ordinary purposes the latter would be four times as rapid.

LENSES FOR CINEMATOGRAPH WORK.

The qualities to be sought for in a lens employed for taking cinematograph pictures are brilliancy of definition, rapidity, and shortness of focus. Lenses of the Petzval type, of from $1\frac{1}{2}$ in. to 4 in. focus, are commonly sold for the purpose; but a specially constructed anastigmat will give better results, owing to its greater flatness of field, better definition, and equality of illumination. A typical lens of this description is shown by Fig. 521. The same lens is often employed for both taking and projecting the films; but this is not always the best plan, as an objective of larger aperture is generally necessary if the maximum illumination is desired.

METHOD OF TESTING LENSES.

Simple tests for the more easily discernible defects of lenses will be found on pp. 34 and 35; it will therefore only be necessary to deal with a few of the less evident faults occasionally met with. One of these, caused by strain in mounting—that is to say, too great pressure of the brass holders or tubing on the lens cells—will sometimes result in giving the objective what is known as a "twist." It is somewhat difficult to detect without

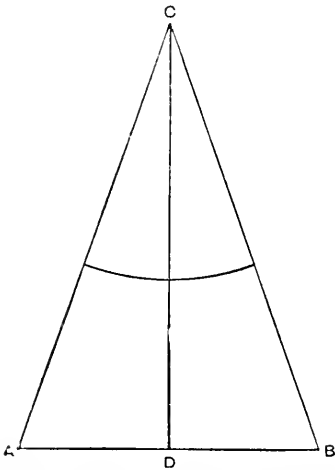

Fig. 522.—METHOD OF FINDING ANGLE OF VIEW.

an expensive lens-testing bench, but may frequently be located by photographing a large chart covered with small circles, drawn by means of a bow compass. If strain is present it will probably be indicated by some of the circles assuming an elliptical form in the photograph. Sometimes the glasses of a lens are not truly centred; this may be roughly tested by slightly unscrewing the lens on the camera front, focussing sharply on a view or chart which will cover the whole of the focussing screen, and turning the lens carefully round, at the same time watching the image on the screen. The camera must be fixed firmly on a perfectly steady support, and care taken not to shake either the camera or the lens while turning the latter. If the image is seen to move about on the ground glass when

the lens is moved, bad centring is indicated—unless, of course, this is due to movement or shaking of any part of the apparatus.

ASCERTAINING THE ANGLE OF VIEW.

The angle of view of a lens may be defined as the angle included between lines drawn from the point of emission or perspective centre of the lens, which is approximately in the centre of the diaphragm, to the edges or corners of the plate it is covering. In other words, the angle of view depends on the focal length of the lens, considered in connection with the longest side of the plate. From this it will be seen that every lens of the same focal length, if used on the same plate, will embrace a similar angle. A simple geometrical method of finding the angle included by any given lens will now be described. Draw a line AB (Fig. 522) equal to the length of the longest side of the plate (or it may be drawn to scale if desired). Perpendicular to this, and bisecting it, draw the line CD , equal to the focal length of the lens. Join CA and CB ; the angle C then represents the required angle of view, which may readily be measured with a protractor. Some prefer to go by the diagonal of the plate, instead of its longest side, in which case the angle of view is evidently larger. It must be remembered that although the angle of view, strictly speaking, is measured from the base or longest side of the plate, the lens must be capable of covering a circle of a diameter equal to the diagonal of the plate, or the corners will not be properly covered.

TABLE OF VIEW-ANGLES.

The following table, drawn up by Clarence E. Woodman, Ph.D., will probably prove useful. To find the angle of view, divide the base of the plate (or, if preferred, the diagonal) by the equivalent focus of the lens. Look in the table for the quotient, or the nearest figure to it, and against this will be found the angle. For example: What angle is included by a 10-in. lens on a 5×4 plate? Divide 5

by 10, the quotient is '5; and against '5 in the table will be found the required angle, namely, 28° .

DIVIDE THE BASE OF THE PLATE BY THE
EQUIVALENT FOCUS OF THE LENS.

If the Quotient is	The Angle is	If the Quotient is	The Angle is	If the Quotient is	The Angle is
282	16	748	41	13	66
3	17	768	42	132	67
317	18	788	43	136	68
335	19	808	44	1375	69
353	20	828	45	14	70
37	21	849	46	1427	71
389	22	87	47	145	72
407	23	89	48	148	73
425	24	911	49	15	74
443	25	933	50	153	75
462	26	954	51	156	76
48	27	975	52	159	77
5	28	1	53	162	78
517	29	192	54	1649	79
536	30	1941	55	1678	80
555	31	1963	56	17	81
573	32	1986	57	1739	82
592	33	1408	58	1769	83
611	34	1432	59	18	84
631	35	1455	60	1833	85
65	36	1478	61	1865	86
67	37	12	62	1898	87
689	38	1225	63	1931	88
708	39	125	64	1965	89
728	40	1274	65	2	90

DIAGONALS OF PLATES.

The diagonals of the plates most commonly used are as follows:—

$3\frac{1}{4}$	$3\frac{1}{4}$...	4.6 in.	$7\frac{1}{2}$	$\times 5$...	9.0 in.
$3\frac{3}{4}$	$4\frac{1}{4}$...	5.3 in.	$8\frac{1}{2}$	$\times 6\frac{1}{2}$...	10.7 in.
5	$\times 4$...	6.4 in.	10	$\times 8$...	12.4 in.
$4\frac{3}{4}$	$\times 6\frac{1}{2}$...	8.0 in.	12	$\times 10$...	15.6 in.
5	$\times 7$...	8.6 in.	15	$\times 12$...	19.4 in.

Those, therefore, who desire to obtain the angle of view by the diagonal measurement of the plate, should use the above figures instead of taking the base measurement.

FLARE OR FLARE SPOT.

These defects have not been considered with the other aberrations of lenses, for the reason that they come in a somewhat different category. A common, badly corrected lens may be free from flare, and an expensive, highly corrected one seriously subject to it. Flare, or flare spot, is due to superfluous light passing

through the lens, other than that forming the image. This may be caused by imperfect blacking of the inside of the lens tube, or by its having rubbed bright with use. The remedy in either case is obvious. Another variety, known as optical flare, is present to some extent in all lenses, and is due to the formation of a secondary image by reflection from the internal surfaces of the glass. The greater the number of reflecting surfaces in a lens, the more danger there is of flare. A certain amount of this cannot be avoided, but it must never be allowed to concentrate over a small area, or a definite patch of light will be formed, known as a flare spot. Where this occurs, it may sometimes be cured by altering the position of the diaphragm, so as to distribute the secondary image or images over the whole field. The Petzval lens, which has a large number of reflecting surfaces, is very prone to give a flare spot if used with a small stop. Simple flare makes itself evident by a lack of brilliancy in the pictures; if present in only a small degree, it is not a serious matter. "Ghosts," or "ghost images," are sometimes caused by internal reflection in the lens or from a bright mount or shutter; they are to be explained and remedied in much the same way as flare.

SHAPE AND POSITION OF DIAPHRAGM.

The diaphragms of lenses intended for ordinary photographic work are circular, although for certain photo-mechanical purposes this shape is departed from. The position of the stop is of considerable importance, particularly in a single lens, where the definition and degree of distortion are greatly influenced by it. The method of finding the best position for the diaphragm, with a single lens, is given on p. 35. The position of the stop has also a great effect on flare. All defects of lenses, except distortion, may be to some extent reduced by stopping down; and the smaller the stop employed, the larger the area of critical definition. The stop must not be too small, or diffraction is liable to take place, to the detriment of the definition.

SELECTING LENSES.

The selection of lenses, of course, depends on the purpose for which they are intended. A lens perfectly fitted for landscape work might be quite unsuitable for portraiture or architectural subjects. There are, however, certain fundamental requirements to which attention must be paid in any case. One is, that the lens should perfectly cover the plate it is to be used with, at its largest aperture. It is advisable also that there should be a certain margin of covering power to spare, to allow for the use of the rising front, etc. Another important point is the focal length, for on this depends the relative size of objects in the picture as compared with the original. For ordinary work the focal length of the lens should be about one-third longer than the longest side of the plate employed; thus, a 12×10 plate may have a lens of about 16 in. focus. The size of the object on the screen is directly proportional to the focal length of the lens; for example, a 10 in. lens will give an image exactly twice the size of a 5 in. objective.

RAPIDITY.

Although this subject has been dealt with elsewhere (p. 33), a few further remarks may not be out of place. The rapidity of a lens depends almost entirely on its effective aperture as compared with its focal length. The measurement of the diaphragm is not necessarily the effective aperture, although it will be so in the case of a single lens with the diaphragm in front. Effective aperture may be defined as the diameter of the bundle of rays which pass through the lens to form the image. Rapidity is also affected indirectly by absorption, scattering, and reflection of light inside the lens. Absorption may occur through the lens not being absolutely transparent, or through discoloration. The transparency of the glass will vary with its quality, composition, and thickness, while discoloration may be due to decomposition of the Canada balsam used in cementing, or to a process of oxidation in the glass itself. Scatter-

ing of light may occur through imperfect polishing of the lens surfaces, and reflection depends on the optical structure and arrangement of the glasses and diaphragm, as explained in dealing with flare (see p. 372). The method of calculating the rapidity of any lens from its aperture will be found in the section on "Exposure of the Photographic Plate."

TO FIND THE EFFECTIVE APERTURE.

The following method is useful when it is doubtful whether the diaphragms are correctly marked or not. Focus for infinity—that is to say, on a distant object; remove the ground glass and replace it with a thin sheet of metal in which a fine hole is bored with a needle. This

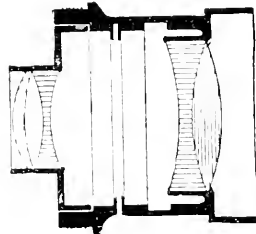

Fig. 523.—SECTION OF ORTHOSCOPIC LENS.

hole must be so situated as to be, as near as possible, in a line with the axis of the lens. A lamp is then placed behind the hole so that a diverging pencil of light is thrown on the lens. If a piece of ground glass is now placed in front of the lens, a disc of light will fall on it, varying with the size of the stop. The effective aperture is obtained by measuring the diameter of this disc. To find the f value, divide the diameter so obtained into the focal length of the lens. For example, if the lens is of 10 in. focus and the disc measures $1\frac{1}{4}$ in., the stop should be marked f 8.

GRADUATION OF FOCUSING SCALE.

A question often asked is how to graduate the scale of a focussing hand camera. The required extension for any distance is obtainable by the formula $\frac{F-D}{D-F}$, F being the focal length of the lens, and D

the distance. For example, with an object 100 ft. distant, and a lens of 5 in. focus, the extension will be $5 \times 100 \div (100 - 5) = 500 \div 95 = 5\frac{1}{4}$ in. The method adopted in practice, however, is to set up a number of test objects, at different measured distances, and to obtain the graduations by actual experiment. This is conveniently done by taking the camera to a field or open space, fastening down a long string or chain with two pegs as a base line, and using a white flag or painted pole to focus on, at carefully ascertained distances.



Fig. 524.—FOCUSSING COOKE LENS.

SPECIAL LENSES.

Besides the various lenses already referred to, there are several others of special make deserving of mention. Among these is the orthoscopic (Fig. 523), designed by Petzval at the same time as his portrait lens, but now little used. It is interesting as being in principle the forerunner of the telephoto lens, having a negative combination at the back, and giving a long focus with a large image. The apochromatic triplet, of which there are several forms, has a central lens of Jena glass which corrects the objective for three colours instead of two; it is, in addition, free from distortion and flare. These features have made the lens a favourite for three-colour work. The Cooke focussing lens (Fig. 524) possesses an arrangement for focussing by turning a graduated ring on the mount, thus rendering it unnecessary to look at the ground glass or to move the bellows. It is on this account peculiarly adapted for use with box hand cameras. The Voigt-

länder Collinear, the Wray Platystigmat, and the Aldis Stigmatic, are all high-class anastigmats, of differing construction but admirable optical properties.

THE UNOFOCAL LENS.

This recently introduced lens, designed by Dr. Rudolph Steinheil, of Munich, introduces a new principle in the construction of photographic objectives; it is known as the Unofocal (Fig. 525). The necessary corrections for astigmatism and

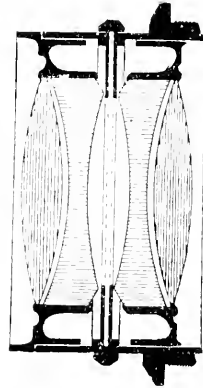

Fig. 525.—UNOFOCAL LENS.

other aberrations are usually obtained by the use of glasses of great curvature. In the lens under consideration, however, these errors are corrected by glasses of very slight curvature and unusually thin and transparent. An anastigmat results which is extremely rapid, the same aperture giving a greater equality of illumination and a larger volume of light than in lenses of the old construction. The definition and covering power are also very fine. A peculiar feature of this lens is that the four elements, two positive and two negative, are all of the same refractive index and focal length. Theoretically, this should result in an exact neutralisation of the combinations, but the necessary power is obtained by placing the lenses at slight distances apart.

THE GRÜN LIQUID LENS.

Considerable interest has lately been attracted by the liquid lens of Dr. Grün,

in which the space between the combinations, or their component glasses, is filled with a transparent fluid of the desired refractive power. A very large aperture with great rapidity thus becomes possible, as a proof of which instantaneous photo-

methods of manufacture and the special treatment required in the evolution of a modern high-class objective. The knowledge of how a thing is made is often of signal service in ensuring that it is used in a proper manner. Especially is this

the case with the delicate and accurately adjusted instruments employed in forming the photographic image, for in some instances the fraction of an inch difference in the separation of the component parts of a lens may make a striking difference in its optical qualities. It is therefore desirable that the following details of the various stages through which the lens has to pass, from the rough glass to the finished objective, should be carefully studied. A good deal of useful information, likely to be of value in ordinary photographic practice, will thus be gained.

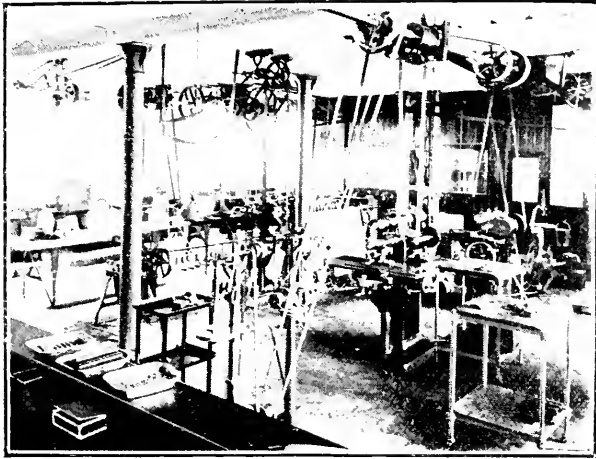

Fig. 526.—TOOL ROOM OF LENS FACTORY.

graphs have been obtained of scenes from a play at night by means solely of the ordinary theatrical lighting. This lens has hardly yet been brought to perfection as regards critical sharpness of definition and a few other factors, but it is by no means unlikely that it may ultimately prove the starting point of a valuable advance in the construction of photographic objectives. The idea is, however, not entirely new, for several early investigators have suggested or made use of a hollow spherical lens filled with water for various optical or other purposes.

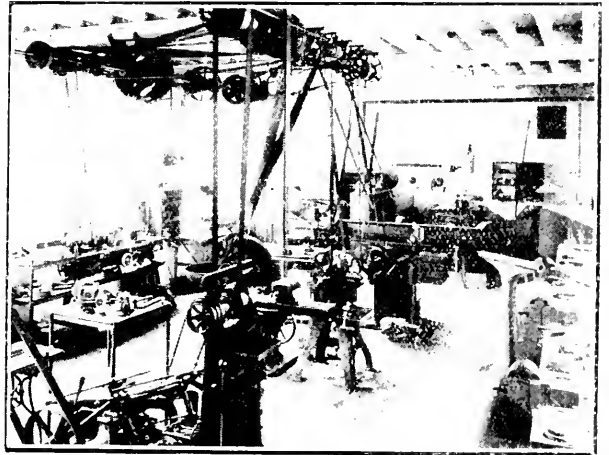

Fig. 527.—MACHINE SHOP OF LENS FACTORY.

LENS MANUFACTURE.

Enough has probably been said of the various classes of lenses and the main optical principles regulating their construction and use. It will now be both interesting and instructive to consider the

EXACTNESS REQUIRED.

There is probably no other branch of manufacture which demands such precision of workmanship as is necessary for the production of photographic lenses. The bricklayer and the tailor are proud

of working within an eighth of an inch, the cabinet-maker of working to a hundredth, the machinist deals in thousandths, the watch-maker in ten-thousandths, but the maker of photographic lenses works in hundred-thousandths of an inch. The slightest failure in working to this scale inevitably results in a defective instrument. Not only in the actual manufacture, but in the designing and the careful preparation of materials as well, experimental investigation and mathematical skill of an equally high order are necessary.

DIFFICULTIES OF MANUFACTURE.

Owing to the specialised character and comparatively limited extent of the in-



Fig. 528.—RAW GLASS PLATES FOR MAKING LENSES.

dustry, suitable machinery and tools cannot be purchased, as looms for weaving may be. Opticians have either to content themselves with relatively crude appliances, or to design and make more perfect ones for themselves. A reference to the well-known Leicester works of Taylor, Taylor, and Hobson will give the reader a good idea of what has to be done. At these works the making of tools receives considerable attention, and a separate department known as the tool-room (see Fig. 526) is devoted to the construction and repair of tools. Another distinct branch of manufacture has arisen in the making of a machine, originally designed for engraving on lenses, but now also used in other industries for requirements as widely different as the construction of moulds for biscuits and the engraving of Maxim guns. Fig. 527 shows the shop in

which machine parts are made on the interchangeable system. In the optical department attention is concentrated solely on the manufacture of photographic objectives, to the exclusion of all other descriptions of lenses, as it is thought that only by such specialisation can the best possible results be obtained. A considerable variety of photographic lenses are made by this firm, the most important being the famous Cooke anastigmat.

SELECTION OF GLASS.

The glass of which lenses are made is purchased in the form of rough plates (see Fig. 528) from various British and



Fig. 529.—"RUBBIED-OFF" GLASS.

Continental makers. Good quality glass is expensive, a plate four inches square costing sometimes as much as fifty shillings. Both faces of these raw plates are ground and polished to facilitate a thorough inspection of the material before it is converted into lenses, and in the course of the examination a large proportion of the glass is marked to be cut out and thrown away. It might be thought that so expensive a material should be free from all defects; but the difficulties in its manufacture are so serious as to make this almost impossible. In order that the various glasses shall possess the necessary refractive and dispersive powers, a large variety of substances are employed by the makers to modify or temper the fusible earths which form the chief constituents of the glass. The perfect incorporation of all these in-

redients by melting and stirring them in a crucible, and the avoidance of discoloration and dirt, is an extremely delicate task. When a mass of glass has been prepared as described, it is allowed to cool and then broken into fragments. The cleanest and most perfect of these are next selected for remelting.

AIR-BUBBLES IN THE GLASS.

As the pieces fuse together, bubbles of air become imprisoned in the viscous mass, and only the largest of these rise quickly to the surface and escape. The smaller ones remain suspended, and can only be removed by patiently waiting until their feeble force at last carries them to the surface. But if one were to wait long enough for the expulsion of all air-bubbles, more serious harm might result: for the same force of gravity which drives these forth works other changes within the body of the glass. Its heavy constituents sink, and the resulting lack of homogeneity, although invisible to the eye, is far more objectionable in a lens than the presence of tiny bubbles, which do not of themselves affect the definition of the instrument in the slightest degree. In fact, in certain optical glasses a few bubbles are a recommendation rather than otherwise, as their presence is proof that the glass has not been spoiled by long continued heating.

COOLING AND ANNEALING THE GLASS.

If the glass is put aside to cool in the ordinary way it tends to contract, and possibly to split. In order to counteract this shrinkage and internal strain, after the glass has been fused into the form of a plate or disc, it is put while red-hot into a specially constructed oven, where it is slowly cooled through a period of several weeks, so that at all times its temperature is as nearly as possible equal throughout the mass. When optical glass is received at the lens works, each piece of an entire batch or melting is marked with a distinguishing number to identify its optical properties, which have been carefully measured and recorded. The plates, then, having been ground and polished as shown

by Fig. 529, are examined critically for any defects, the glass in its present state being known as "rubbed off." By the use of a special instrument (Fig. 530), particles of dirt, veins, or bubbles are made visible, and such defective portions of the plate are cut off and thrown away. The use of polarised light enables any internal strains also to be detected. By the time these selective processes have been carried out, the raw material, expensive in its first state, has become still more valuable, and is now ready for making into lenses. For convenience, the term lens, which is



Fig. 530.—EXAMINING GLASS FOR DEFECTS.

generally applied to the complete objective only, will henceforth be used in speaking of the simple lens or part, composed of one piece of glass, several of which are combined to form the complete instrument.

RELATION OF DENSITY TO CURVATURE.

The glasses of a lens may be ground to a large variety of different curves, these being limited, however, by the optical properties of the glass employed. The density and the refractive and dispersive powers of the glass have all to be considered when plotting the curves. A degree of curvature which would be suitable for one kind of glass may be absolutely undesirable and impossible with another. The optician is supplied by the glass maker with full particulars as to the characteristics of each sample, and is

thereby enabled to design and plan, with unerring accuracy, the requisite curvature needed by each combination to produce a given result.

INFLUENCE OF CURVATURE ON FOCUS.

The focal length of a simple lens made from any given kind of glass will be lengthened or shortened according to the curvature given to it. Still, it does not follow that two lenses of similar curvature, but of different kinds of glass, will have the same focus. As a matter of fact, if the refractive index of the glass is varied, the foci of the two lenses will vary also.



Fig. 531.—"ROUGHING" LENSES.

These variations are of immense value to the optician, rendering it possible to produce lenses of almost perfect correction, suited to widely different purposes and requirements. It is evident, however, that the designing of modern objectives is no longer the simple matter it was at one time, when there were practically but two kinds of glass obtainable. With the many varieties of glass now obtainable the work has become far more complicated and difficult, requiring highly specialised knowledge and skill, although, at the same time, the inherent optical defects of a lens can now be more satisfactorily corrected.

"ROUGHING" LENSES.

There are two methods of shaping glass, one being to heat it till it becomes plastic, and the other to break off or grind away

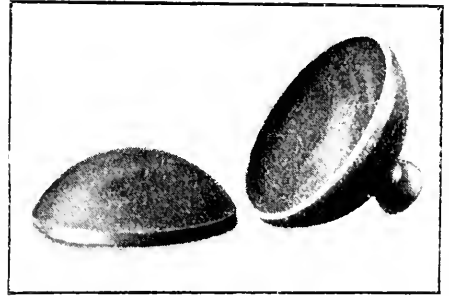

Fig. 532.—LENS GRINDING TOOLS.

the superfluous parts of a rough piece until it is suitably formed. Cheap lenses are sometimes made by the former method, but it is quite unsuitable for the manufacture of high-class objectives, which can only be properly obtained by the latter method, as now to be described. Unless intended for a large lens, one plate of glass will probably suffice for several lenses, and will have to be cut in slices to make it thinner. This is done by sawing



Fig. 533.—GLASS GAUGE AND TOOL RACKS.

it with a rotating disc, with tiny diamond points set in its rim. This slowly and

steadily makes its way through the glass, dividing it into slices of suitable thickness. From these pieces circular discs are made, which are then roughly shaped to the spherical curvature required by a

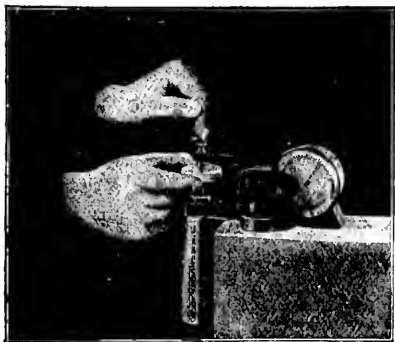

Fig. 534.—MEASURING THICKNESS OF LENS.

Emery is used at first, carefully sorted into different grades by placing in water and allowing to settle; the operation being repeated many times, so that a finer sediment is secured at each. Very accurate grinding tools are necessary; these are made in pairs, one convex and the

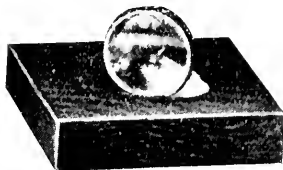

Fig. 536.—CONTACT GAUGE AND CASE.

revolving spindle having attached to it a metal tool shaped to the counterpart of the desired curve (see Fig. 531). This tool is supplied with a coarsely powdered

other concave, the two being ground together until not only of the correct curvature, but so perfectly spherical that they meet perfectly in any position of contact (Fig. 532). Large numbers of these accurate tools are required, varying in size and curvature. Racks containing these tools, with their profile gauges, are shown in Fig. 533. With these appliances and



Fig. 535.—POLISHING LENSES.

abrasive, such as emery or carborundum, and with water to secure cool working.

ROUGHING TOOLS AND GAUGES.

The lenses thus roughly shaped are now ground with a series of tools more and more accurately formed, and with abrasives more and more finely powdered.

various grades of emery the surface of the glass is gradually changed from its previous coarsely ground condition to one free from scratches and showing signs of polish.

MEASURING AND POLISHING.

Meanwhile, the axial thickness of the lens is measured by means of a little

instrument which indicates the required details on a dial, and enables minute accuracy to be maintained (see Fig. 534). The lens now, although tolerably smooth, requires to be submitted to the operation of polishing, which will further reduce the almost imperceptible remaining roughness of the glass, by abrasion with still finer substances than have been previously employed. Even the finest emery would be too rough for this work, and metal tools have to be at this stage abandoned. The

hand polishing, the glass is fastened with pitch to a suitable handle (Fig. 535), and the polishing tool is rotated on a spindle. The rotating tool is lightly coated with the moistened abrasive, the lens is held against it so that their spherical surfaces are in contact, and the operator with a rapid and delicate motion of the hand, which can only be properly acquired by experience, rubs the surfaces together, changing continually the position of the lens, and so securing the equal polishing of the whole surface.



Fig. 537.—EXAMINING CONTACT.

abrasives employed for polishing are various earths and metallic oxides, such as tripoli, rouge, and putty powder (oxide of tin), and these are applied with water upon rubbers made of some soft substance. Cheap lenses are frequently polished with rubbers made of paper or cloth, which act quickly but are apt to destroy the perfect sphericity of the lens by over-rubbing and rounding the outer margins. For polishing the best lenses, rubbers made of waxes or resins are used; these, although so soft as not to scratch the glass, are inelastic, and cannot, if properly applied, distort the curvature of the lens. These wax polishers are held in supporting shells of metal. Exceptional skill is required for this work, and much of it has to be done by hand to secure the best result. In

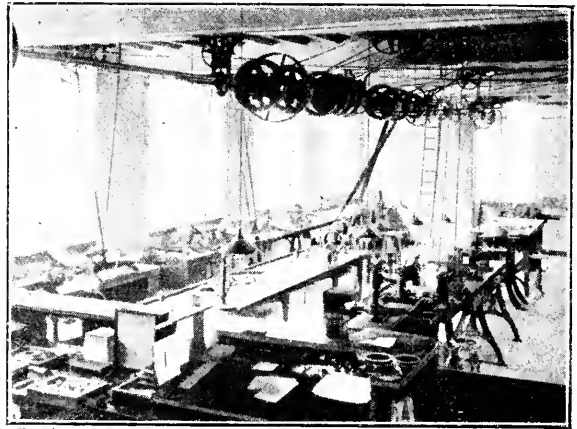

Fig. 538.—BRASS PREPARING SHOP.

EXAMINING CONTACT.

At intervals during the process the work and the tool are cleaned, and fresh abrasive applied to continue the operation until it is complete. At each interval the lens is carefully examined, and as it approaches completion the accurate formation of its surface is tested by means of what is called a contact gauge. This consists of a piece of very hard glass (Fig. 536), having on it a spherical surface, ground and polished with great accuracy, an exact counterpart of the surface it is desired to test. When the gauge and the lens to be tested are very carefully wiped, placed together, and viewed by reflected light, as shown in Fig. 537, brilliant colours are seen, formed by interference at the two contact surfaces, colours which exactly resemble those seen in soap bubbles. These colours can only be pro-

duced when the two surfaces which form them are exceedingly close together. They have their maximum brilliancy when the surfaces are a few millionths of an inch apart; and if the separation of the surfaces varies, the colours change and spectrum bands are formed. It is by noting the brilliance, the form, and the separation of these bands of colour that the lens maker is able to measure and to work with so great a degree of precision and exactness.

EDGING AND CENTRING.

It is of great importance that all the glasses forming a lens should have the centres of their curves in one straight line, which is afterwards known as the

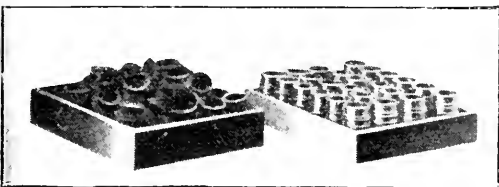

Fig. 539.—TRAYS OF ROUGH AND FINISHED BRASS-WORK.

axis of the lens. To effect this, they are at first ground and polished to a slightly larger size than will be required when finished. The next proceeding is to centre them on a lathe until they reflect a perfectly stationary image when revolved. The edges are then carefully cut with a diamond to fit the brass cell exactly. The utmost precision is required in doing this, for if any of the curves are in the slightest degree out of centre the efficiency of the lens is disturbed.

DANGER OF SHIFTING THE COMBINATIONS.

A few words of warning may here be given to those photographers who are in the habit of unscrewing the combinations of their lenses, either out of curiosity or to clean them. If the objective is at all complicated in construction, this should never be done, for with many high-class lenses the slightest difference in the

separation will be detrimental. Such a lens should always be taken to an optician if it requires cleaning. These remarks do not apply, it need hardly be said, to those lenses known as convertible, or to sets of combinations intended for transposition. Nor is the same caution required with lenses of simple arrangement. There is, however, one point which requires atten-



Fig. 540.—CALLIPER LIMIT GAUGE.

tion, even as regards the latter: care should be taken, in replacing the glasses, that they are put the same way round as before. A lens may appear to be ground exactly the same on both sides, and yet the curves may be in reality dissimilar. This precaution is especially important in the case of single lenses in hand cameras.

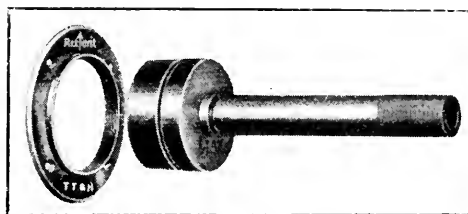

Fig. 541.—PLUG LIMIT GAUGE.

INSPECTION OF LENSES.

When the workman has finished his batch of lenses they are inspected by the foreman and then forwarded to the lens testing room, where they are again examined separately by means of instruments presently to be described; and if passed as perfect they are received into stock, to await the arrival of their metal settings, before being assembled and adjusted as complete lenses.

PREPARING THE BRASSWORK.

The machines employed for this are of a more or less familiar description. The

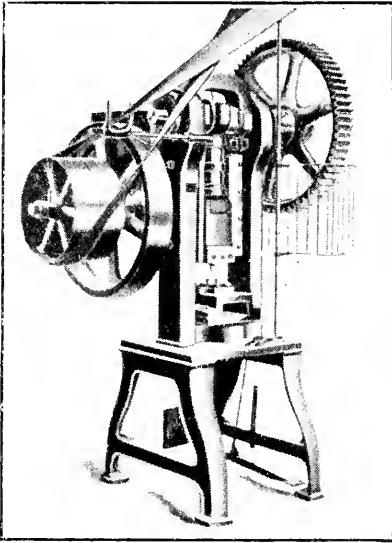

Fig. 542.—POWER PRESS.

lathe, the milling machine, drilling apparatus, presses, and many other tools are used, but scarcely need any special ex-

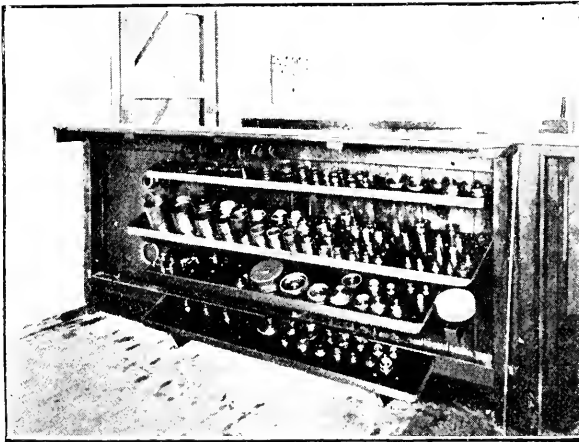

Fig. 543.—RACK OF INTERCHANGEABLE CHUCKS.

planation. What is of peculiar interest at the Leicester factory, however, is that,

breaking away from the traditions of the lens-making industry, the work is carried on as far as possible upon the interchangeable system, all dimensions and measurements having prescribed for them certain well-defined limits of permissible error, maintained by the use of accurate



Fig. 544.—LACQUERING BRASSWORK.

gauges and inspection of each piece at every stage. Figs. 538 and 539 show, respectively, the brass preparing shop and trays of raw and prepared work. The majority of the parts of a lens mount are in the form of rings, which are first roughly shaped by casting, or made from tubing or sheet metal. The pieces are accurately shaped by turning them in a lathe with various cutting tools, which form upon them their screws, shoulders, recesses, or other necessary details.

HOW ACCURACY IS SECURED.

The workman is furnished with gauges for each essential detail. Fig. 540 shows the method employed for gauging an exterior screw. The hardened steel gauge or calliper has in it two gaps, one on each side, which are used separately to gauge the screw diameter. If, for example, this diameter be nominally 2 in., one gap in the calliper is exactly 2 in. across, and the other only $\frac{1}{1000}$ in. smaller. The

screw is so cut that it will pass through one gap but not the other; when this condition is satisfied, the variation between any two screws cannot possibly exceed $\frac{1}{10000}$ in. Fig. 541 shows the device employed for ensuring corresponding accuracy in the interior screws. This consists of two hardened steel cylindrical gauges provided with a handle, one of these being just $\frac{1}{10000}$ in. smaller than the other; one of these gauges must pass freely through the screw, while the other

mounts, especially those subject to wear, with which it is found advisable to secure still greater accuracy, while hardening their surfaces, by subjecting them to heavy pressure in finely polished hard steel dies. The power press (Fig. 542) is used in this process, and has proved capable of securing uniformity in the sizes of pieces within limits of $\frac{1}{10000}$ in.

FINISHING THE METAL-WORK.

The batch of parts, having passed through their various stages of manufact-



Fig. 545.—ENGRAVING THE LENS MOUNT.

will not. Thus no two screws will jam, out of any possible combination that can be made. Hundreds of such gauges are used for the many dimensions required in lens settings, all being periodically inspected for signs of wear. To overcome the difficulty of expansion by friction, compressed air is blown upon the work to keep it cool. Even with this and other precautions, it is found difficult to shape metals, by means of cutting tools alone, within limits of error much smaller than $\frac{1}{10000}$ in. And although such variations are really small compared with those commonly to be found in good instrument work, there are some parts of lens



Fig. 546.—USUAL FORM OF SCREW THREAD.

ture, are carefully inspected in detail, any which do not fulfil the prescribed conditions being at once rejected. The passed pieces are then received into stock, and presently, with other parts, are finished and assembled to form complete lens settings. In finishing, the object is to retain the accuracy already given to



Fig. 547.—THE "T, T. AND H." PATENT SCREW THREAD.

the pieces, and at the same time to give them the good appearance of finished work. Fig. 543 shows a rack of interchangeable holders or chucks, by means of which the prepared parts are held true in various machines. The polishing of brasswork calls for no particular remark. The fluting of the rims of the cells, a marking similar to that seen on the periphery of silver and gold coins, is produced in the lathe by rotating the piece and impressing it with a steel roller having the requisite pattern cut in its rim. The lacquer or varnish, used to preserve the metal-work from tarnishing,

is composed of shellac dissolved in alcohol. As shown in Fig. 544, the lacquer

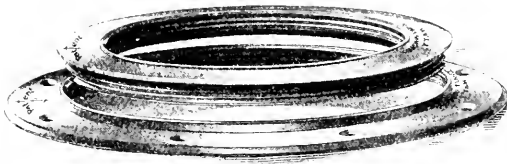

Fig. 548.—METHOD OF STARTING PATENT SCREW.

is applied with a brush, the work having previously been heated sufficiently to evaporate the alcohol as the lacquer is applied. The shellac is thus distributed evenly over the surface, and becomes hard as the metal cools. It will be seen that mounts should not afterwards be unnecessarily warmed, or the lacquer may thus be softened and damaged; nor should they be washed with alcohol, as is sometimes advised, for that removes the shellac.

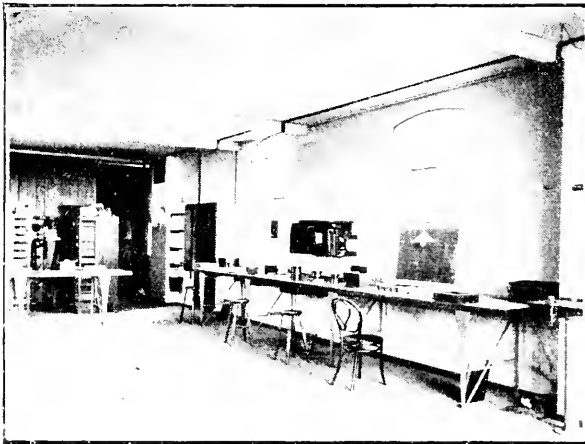

Fig. 549.—LENS TESTING ROOM.

ENGRAVING THE SETTINGS.

After the different parts are lacquered, the scales for iris diaphragms, distances

for focussing, and all other inscriptions usually found on a lens, are engraved upon the mount by the machine shown in Fig. 545, of which mention has already been made. This machine is, in principle, a development of the well-known pantagraph. A copy of the inscription to be engraved is used, several times larger than required, and the operator, by moving a style along the lines of this copy, works a graving tool about the lines to be engraved. The

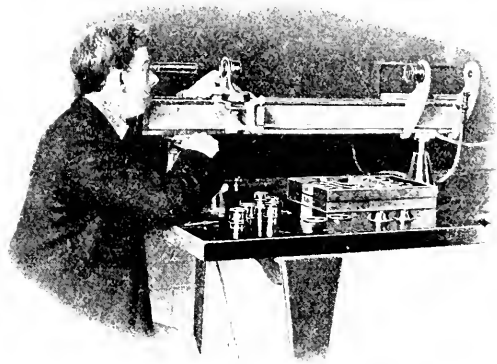

Fig. 550.—ASSEMBLING AND ADJUSTING LENSES.

graving cutter is a tiny tool rotating several thousand times a minute. When finished, the settings are once more inspected in detail, after which the lenses are fixed into them.

NEW METHOD OF SCREW THREADING.

The difficulty of getting two fine threaded screws to fit together properly, in lens flanges, etc., is familiar to every photographer. This is due to the tapering end of the thread (A, Fig. 546) acting as a wedge and causing the screws to jam unless started in the right manner. It is always awkward to find the correct starting

point with such screws, because the bevelled end B, when applied to its mate, acts like the ball in a ball and socket

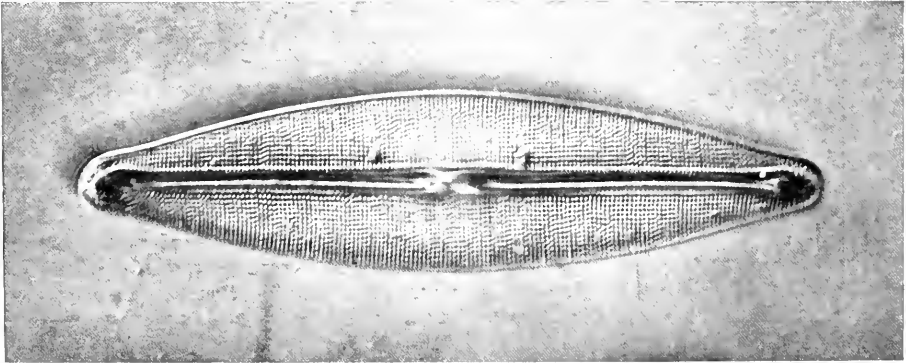

NAVICULA CRASSINEEVIS. (X 2,160 DIA.)
ZEISS APOCHROMATIC OBJECTIVE 2 MM.
AND COMPENSATION EYEPIECE 18.



TETANUS OR LOCKJAW BACILLI. (X 1,000 DIA.)
ZEISS APOCHROMATIC OBJECTIVE 3 MM. AND COMPENSA-
TION EYEPIECE 4.

SPIRILLE OF ASIATIC CHOLERA. (X 1,000 DIA.)
ZEISS APOCHROMATIC OBJECTIVE 3 MM. AND COMPENSATION EYEPIECE 4.

BACILLI OF TYPHUS. (X 1,000 DIA.)
ZEISS APOCHROMATIC OBJECTIVE 3 MM. AND COMPENSA-
TION EYEPIECE 4.

joint, and there is nothing to guide the two screws into the required axial relationship. In the patent screw of Taylor, Taylor and Hobson (Fig. 547) the tapering commencement of the thread is removed so that it begins abruptly at full section and cannot jam. This is done to both external and internal screws, the place where the thread commences being marked upon each by an arrow, as shown on the left in Fig. 548. When these two

general method of testing. The action of a photographic lens in forming an image is simply to receive light from each point of the object, and to condense this to corresponding points forming the image, and the capacity of a lens for fine definition depends practically on its power to condense, very accurately to a point, the light which it receives from any other point. Accordingly, in testing lenses, instead of merely putting a lens in a camera,

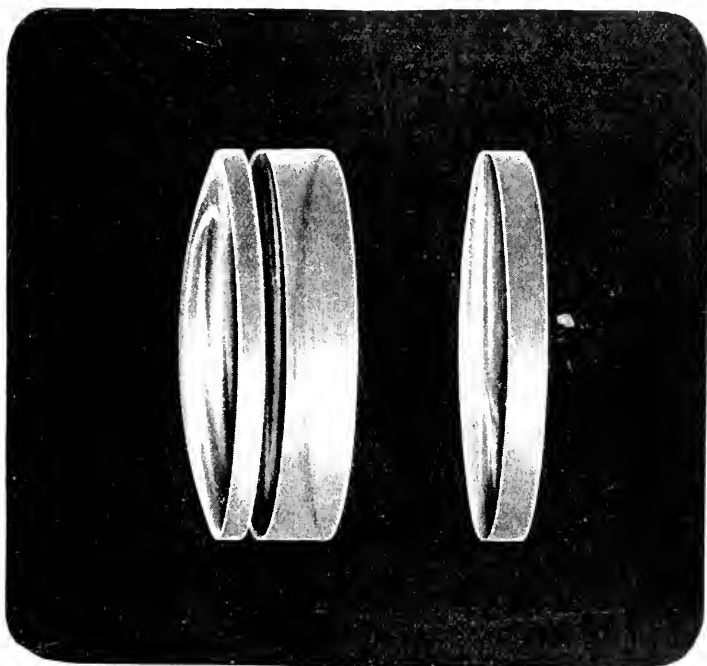

Fig. 551.—THREE SIMPLE GLASSES OF COOKE LENS.

arrows are brought together, and the screws are turned, they at once engage without the least difficulty.

TESTING THE LENSES.

The lenses are finally adjusted in the testing room (Fig. 549), where every lens is thoroughly examined for all possible defects. It would take too long to describe minutely all the appliances employed for the optical tests. It will probably be sufficient, while giving brief particulars of certain instruments, to point out the

focussing an image, and attempting to judge whether it is sharp or not, the lens is first inserted in an instrument like that shown in Fig. 550. At the end furthest from the operator is a small flame or source of light, bounded by a pin hole. The light, passing through the tiny opening, spreads out in conical form until it reaches a condensing lens, known as a collimator, which renders the light rays perfectly parallel, so that they behave as if they had come from an infinite distance. In the path of these parallel rays,

and near the operator's left hand, the lens to be tested is supported, and the light which it thus receives is condensed to a point, which is examined by the aid of a microscope, as shown. By examining this point of light, and moving the lens so that the light passes through it in various directions, the operator is able to ascertain a great deal more about its defining power than by merely taking photographs with it.

ADJUSTING THE GLASSES.

A peculiarity of the Cooke lens in which it differs from others is its capacity for ad-

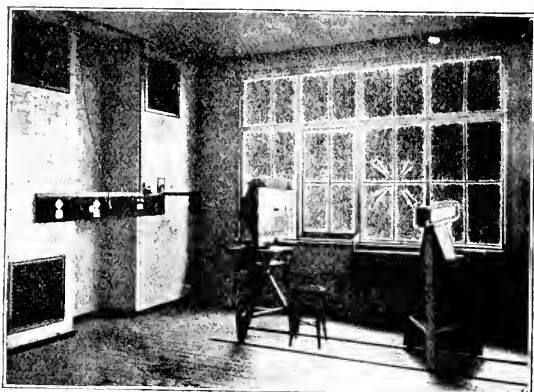

Fig. 552.—TRAMWAY CAMERA.

necessary to obtain flatness of field and freedom from distortion are shown by Fig. 552. A number of test objects, fastened on the wall, are in a plane normal to the axis of a special tramway camera. The latter runs on rails which guide it truly, and the focussing is done within the camera itself. Images of the test



Fig. 553.—SPECIAL CAMERA FOR TESTING LENSES.

justment. As shown by Fig. 551, it consists of three simple lenses. The middle glass is held by screws which are used in the final assembling to set it perfectly in agreement with the other two, this work being done by the aid of the instrument just described. By its means the lens is adjusted so that it produces sharp definition when turned in any direction, and so that the image seen in the microscope remains stationary while the lens is rotated upon its axis. When this is attained, it is certain that it will give sharp definition at any part of its field, but it is not yet assured that the image is flat and free from distortion. Adjustment in these respects is obtained by varying the separation of the glasses, without disturbing the axial adjustment already made. Appliances used for the adjustments

objects are magnified and examined in the focal plane, and, by a special device in the camera, charts are drawn to record the form of field and the astigmatic corrections of any lens tested. The same camera contains a means for measuring distortion, a colour test is applied by another attachment, and the prismatic support in the rear is an extension capable of accommodating the largest photographic lens ever made.

METHOD OF TAKING TEST PHOTOGRAPHS.

The focal length of lenses is ascertained by means of a special photographic testing

camera, which makes test photographs in the form of strips, a number of which can be taken on one plate for the purpose of easy comparison. These tests are for determining the final adjustments of lenses, and for comparing the working of different types. A peculiar form of camera, constructed to enable visitors readily and exactly to compare the working of various lenses, is shown by Fig. 553. The ordinary camera used for this purpose is unreliable, its focal plane often being imperfectly square to the lens axis or not parallel with the test object. This special camera is made rigidly of metal, and, by a novel arrangement of guides, its planes remain parallel, and its slides free from shake, in spite of wear. The focussing screen is supported on roller and ball bearings, which work with perfect freedom.

OBSTACLES TO PERFECT DEFINITION.

Some remarks may here be made on the weakness of construction, optically speaking, of many cameras now on the market. Sir William Abney has declared that the barrier to finer photographic definition lies not so much in the lens, which is perhaps as perfect as it can well be, but in the coarseness of structure of the modern sensitive film. It is well known to opticians that this is the case; but they are also aware that this is not the only factor

which limits the definition in ordinary photographs. Where most photographers fail in getting the utmost possible effect from their lenses is in the imperfect setting of the film in the true plane of the image; and this failure is due not so much to want of care or knowledge on their part, as to the loose, elastic, and optically inaccurate construction of the average camera.

CARE AND PRESERVATION OF LENSES.

After what has been said with regard to the delicate and precise methods employed in the making and finishing of lenses, it is hardly necessary to insist on the advisability of extreme care being taken to guard against scratches or damage to the highly polished surface of the objective. Lenses should never be exposed to extremes of heat or cold, nor to the rays of the sun, which frequently have an injurious effect on the glass. Moisture or steam must not be allowed to settle on the surface of the lens; nor should the surface be touched with hot fingers, as this will sometimes cause a stain. Knocking or dropping the lens should be avoided, not only for the obvious reason that the glasses may be broken, but because a slight dent on the mount may cause strain and "twist." Some useful hints on dusting lenses, etc., will be found on p. 30.

THE CHEMICAL ACTION OF LIGHT.

INTRODUCTION.

THE precise character of the action of light in photographic processes has not yet been satisfactorily explained. Several theories have been advanced to account for the different effects of light upon sensitive salts, but these are all more or less of a speculative nature. The subject is a wide one, for the substances and reagents so affected are very numerous, although the actual number of those which have been found suitable for photographic purposes is comparatively small. The silver salts hold the most important place at present, but it is probable that a more definite and exact idea of the process by which the latent photographic image is formed will lead to the employment of many now unknown or seldom used chemical compounds.

EXPERIMENTS WITH DYES.

Scarcely anyone can have failed to notice the remarkable bleaching effect that continued exposure to a bright light has on certain colours and dyes. This is one of the simplest examples of the direct chemical action set in motion by light. It may be due sometimes to the liberation of chlorine, or to the production of free oxygen: in other cases, reactions of a more complex character take place. Some colours are much less easily bleached by exposure to light than others. These are known as "fast colours"—that is to say, they have been chemically treated during dyeing in such a manner that the colour is no longer subject to any disturbance or deterioration, but is rendered stable and permanent. It is a curious fact that no dye will bleach out

by exposure to light of its own colour. This principle has been turned to account in the Szczezanik process of colour photography, in which a mixture of fugitive red, yellow, and blue aniline dyes, incorporated in gelatine, is used to coat glass or paper. This is afterwards exposed under a coloured transparency, or similar object, when the yellow and blue dyes fade under the red portions of the picture, leaving only the red, and so on, with the result that the colours of the original are correctly reproduced.

EFFECTS OF DYES ON SENSITIVE FILMS.

In 1874, Dr. H. W. Vogel, of Berlin, found that when films were treated with certain aniline and other dyes, the plate showed an increased sensitiveness to those portions of the spectrum which the dye was capable of absorbing. Dyes which acted in this manner were called, by Vogel, "optical sensitisers"; and, in his opinion, they might act in both an optical and a chemical direction. The propriety of the term "optical sensitiser" has been warmly contested: the general opinion being that it is a misnomer, the action of the dyes being more of a selective and chemical nature. Abney, in 1875, gave what is probably the true explanation, by demonstrating that certain dyes combined chemically with silver, forming coloured organic silver salts, sensitive to light. In confirmation of this, Dr. Amory succeeded in obtaining a photograph of the spectrum by means of a sensitive compound of silver and eosine. Major J. Waterhouse had also been engaged in similar experiments, and proved

that the various rays of the spectrum took effect only when absorbed by the compound. Another valuable and suggestive discovery by Abney was that, in many cases, the dyes themselves were reduced by the action of light, thus forming, as it were, a nucleus for the after deposition of the silver during development. Abney's theories have not gained universal assent. Eder and Vogel held the view that the energy absorbed by the dyed silver salt is partially employed in effecting the chemical decomposition of the latter. In

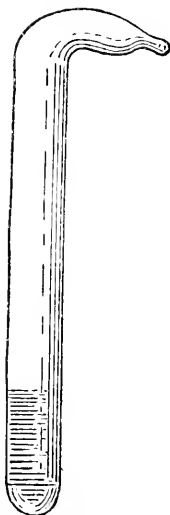

Fig. 554.—SILVER CHLORIDE IN SEALED TUBE.

1895, Mr. C. H. Bothamley, in a paper read before the British Association, ably summed up the matter as follows:—"The balance of evidence is greatly in favour of the view that the dye absorbs the particular groups of rays, and, in some way which is not at all clear, hands on the energy to the silver bromide with which it is intimately associated, and which is thereby decomposed." This part of the subject will be treated with further detail in the section on "Orthochromatic Photography."

ACTION OF LIGHT ON SILVER CHLORIDE.

The darkening effect of light on silver chloride appears to be due to the libera-

tion of chlorine, and the consequent deposition of metallic silver. It is necessary, however, that some body shall be present which is capable of absorbing the chlorine—or, at any rate, that the latter should be free to escape. A glass tube (Fig. 554) of dried silver chloride, from which the air has been expelled previous to its being hermetically sealed, will not discolour in the light in the slightest degree. If, however, a bent tube (Fig. 555), containing silver chloride at one end and a drop of mercury at the other, is sealed up in a similar fashion, the result will be different. The mercury gives off a certain

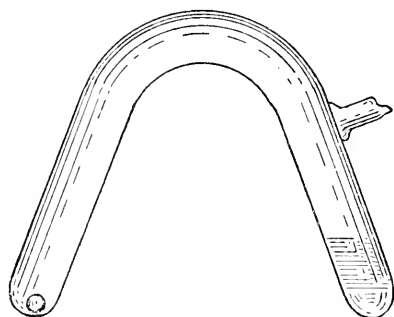

Fig. 555.—BENT TUBE FOR EXPERIMENT WITH SILVER CHLORIDE.

amount of vapour, and when exposed to the action of light, chlorine, which has an affinity for the mercury, is liberated, and mercurous chloride (Hg_2Cl_2) is formed on the sides of the tube. As a consequence, a small quantity of metallic silver is set free, and the chloride accordingly darkens.

ACTION OF LIGHT ON METALLIC SILVER.

The discovery that silver is sensitive to light was made by Moser, who placed a silver plate under an opaque cut-out screen, but not in contact with it, and exposed it for some hours in sunlight. The plate, which showed no apparent change, was allowed to cool, and held over the vapour of heated mercury. A clear image of the screen was produced by the deposition of the quicksilver on those parts where the light had

acted. Plates of copper treated in the same way gave a similar result. Many explanations have been offered to account for these effects, but nothing is known positively. It is probable that the intimate connection which exists between light and electricity is responsible for this and many similar manifestations.

THE HALOGENS AND THEIR PROPERTIES.

The halogens commonly used in photography are chlorine, bromine, and iodine; the fourth, fluorine, being scarcely ever employed. As is well known, they form, when mixed with silver, compounds of great sensitiveness to light. They are characterised by a strong affinity for hydrogen, which accounts for the ready decomposition of bodies containing them on exposure to light, either in the presence of water or of organic bodies containing hydrogen. Chlorine combines directly with hydrogen under the action of light; bromine will do so at a high temperature, but iodine will not. A solution of iodine in alcohol, however, is decomposed to a slight extent by exposure, and the blue compound of iodine and starch is decidedly sensitive. Silver chloride is rapidly acted on by light, the chlorine being liberated and metallic silver deposited. The bromide and iodide of silver show little or no change, but require development for the production of an image. An exception to this rule is found in the case of the Daguerrotype plate, where, owing to a large excess of silver, the iodide darkens readily. Silver bromide, too, will quickly change colour by exposure in presence of free silver nitrate, which is also frequently used to increase the sensitiveness of chloride papers.

DEVELOPING POWER OF YELLOW AND RED LIGHT.

A curious feature of the Daguerrotype plate is the remarkable effect of either red or yellow light upon undeveloped images, obtained either in the camera or by printing out. If a short but sufficient exposure is given to an iodised silver

plate, and it is then placed under a red glass in the sun for from fifteen to twenty minutes, a completely printed-out image will result, while the previously unexposed portions remain unaffected, and may be fixed out as usual. An exposure under yellow glass has a similar effect. Dr. Vogel has suggested that during the first exposure a sub-salt is formed, which has the effect of altering the absorbing properties of the plate, so that it becomes sensitive to the red and yellow rays. Other sensitive surfaces behave in the same manner, and attempts have been made at various times to turn the phenomenon to practical account. It certainly appears to contain the germ of possible future advances in photography.

SENSIBILITY COMMON TO NEARLY ALL BODIES.

From what is known of the action of light it would seem that almost every body and compound is more or less sensitive to its influence. All that is required for the demonstration of the fact is the knowledge of appropriate developers, or of the conditions by which an image may be made manifest. It would also appear that, given a favourable opportunity, all the rays of the spectrum are capable of causing some physical or chemical reaction, even in substances regarded as being insensitive. This aspect of the subject, however, has hardly gone beyond the stage of inquiry and speculation.

NECESSITY OF HALOGEN ABSORBENTS.

To A. L. Poitevin and Dr. Vogel is due the discovery that, for the reduction of the haloid salts of silver by the action of light, the presence of a halogen absorbent—that is, a substance which will absorb the liberated chlorine, bromine, or iodine—is necessary. It is by the application of this law that the present speed of plates and films has been attained. As far as can be ascertained, light exerts a reducing action, which is assisted by the presence of other bodies, if it is not actually due to them, eager to absorb the liberated halogens. When exposure takes place

without the presence of an active absorbent of the halogens—as, for instance, in the air—a different result is produced. The molecules of the transformed haloid salts absorb the oxygen, and form oxides.

ELIMINATION AND RESTORATION OF THE LATENT IMAGE.

A curious experiment may be made to demonstrate the effect of oxidation. If a sensitive salt, after exposure to light, is treated with an oxidising substance, such as potassium bichromate or permanganate, no image can afterwards be developed, the latent image having been eliminated. Knowledge of this, by the way, is of value in the restoration of accidentally fogged plates. If, now, the oxidised salt is submitted gradually and cautiously to the action of nascent or freshly liberated hydrogen, the oxygen is withdrawn, and the image can again be developed. These phenomena have received various explanations.

EFFECT OF THE SPECTRUM ON SILVER SALTS.

In 1810, T. J. Seebeck noted the production of colour on silver chloride by the various rays of the solar spectrum. The violet rays changed it to brown, the blue gave rise to a certain shade of blue, the red helped to produce a red, while the yellow had no effect. It should be remarked, however, that if Seebeck had employed a pure spectrum the red rays would have made no impression. The fact that the violet and blue rays had more effect than the others had long before been ascertained by Scheele and Senebier (see p. 3). Sir John Herschell, in 1840, gave the result of experiments with the action of light on a large number of different bodies. Since that period other investigators have followed the same path, among whom may be mentioned Edmund Becquerel, Niépee St. Victor, Poitevin, Draper, Robert Hunt, Vogel, Schumann, and Abney. The account of these researches belongs properly to the history of Colour Photography, and will be given in the section devoted to that subject.

ACTION OF LIGHT ON COPPER SALTS.

Cupric salts behave like those of iron and mercury in the presence of light, undergoing reduction and producing cuprous compounds.

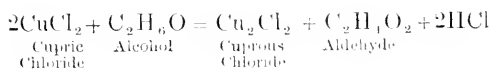

It is interesting to notice that cuprous chloride is capable of still further light treatment. If a clean copper plate is immersed in a solution of cupric chloride, a deposit of cuprous chloride is formed on its surface. If such a plate is partially covered and exposed to the light, the exposed part turns black whilst the unexposed part remains a greyish white. As was noticed in connection with silver chloride, the composition of this dark cuprous chloride is not known. It may be a subchloride, an oxy-chloride, or again it may be cuprous chloride under molecular strain. Schneeberger, in 1899, made a series of experiments with copper salts, with a view to ascertaining if they could be used to replace silver. Cuprous iodide (Cu_2I_2), moistened with ammonia, was exposed in sunlight, a portion being shaded with an opaque card. The part exposed to the light assumed a deep blue tint, the covered portion remaining a pale blue. When the air was excluded, the exposed cuprous iodide blackened, the unexposed part being white. A gelatine emulsion was made with iodide, sensitised in weak ammonia, and the air excluded by the agency of petroleum. A plate coated with this was exposed while in the ammonia, and blackened as before, but became white again on being placed in the dark. When the plate was removed from the sensitiser, washed, and subjected to a bath of dilute sulphuric acid, it developed up with a black colour. An emulsion was also made with cuprous oxide (Cu_2O), and exposed in water acidulated with sulphuric acid, the air being excluded. This plate also assumed a black colour, which it retained when washed and dried, fixation being effected by means of dilute hydrochloric acid.

Some other salts of copper are sensitive to the action of light; but none of them, apparently, can for practical purposes compete with the salts of silver.

ACTION OF LIGHT ON FERRIC SALTS.

In general it may be said that light has little or no action on salts of iron, uranium, gold, copper, mercury, and other metals, if they are dry and are completely removed from such substances as organic matter and compounds capable of undergoing oxidation. In the presence of organic matter and light, however, all these metals, when in the oxidised condition, undergo chemical reduction. Several iron compounds are of great importance in photography, being essential in the platinotype, ferro-prussiate, and their related processes. Bestusheff, in 1725, was one of the first to investigate the effect of light on ferric chloride dissolved in alcohol. Nearly all the iron printing processes are based on the fact that ferric salts are reduced to the ferrous state by exposure to light. Ferric oxalate, for example— $\text{Fe}_2(\text{C}_2\text{O}_4)_3$ —is converted by the action of light into ferrous oxalate, FeC_2O_4 . Potassium ferri-cyanide changes the latter into insoluble Prussian blue, while the unreduced ferric oxalate, which is nearly colourless, being soluble, can be removed by washing. If ferri-cyanide instead of ferri-cyanide be employed, the exposed portions remain colourless, and the unexposed parts are turned blue. The paper commonly used for making blue prints from tracings, etc., is coated with a mixture of ferric ammonium citrate, potassium ferri-cyanide, and gum arabic solution.

IRON SALTS IN PLATINUM PRINTING.

The platinotype process is really dependent on the conversion of ferric salts by the action of light. The paper is coated with a ferric salt and potassium chloroplatinite; light reduces the ferric salt to the ferrous state, and on the application of a developer, which brings the ferrous salt into action with the platinum compound, an image is formed by the reduction of the platinum. There

are various modifications of the process, but they are all based on the reduction of a ferric salt by exposure; direct printing with salts of platinum does not appear to be practicable.

SENSIBILITY OF FERRIC CHLORIDE TO RED RAYS.

Sir John Herschell, and later Lord Rayleigh, carried out many experiments with ferric chloride, Fe_2Cl_6 . This salt has several remarkable properties. If solutions of ferric chloride and potassium ferri-cyanide are brushed over paper, and the paper is then exposed to a brilliant solar spectrum, a visible effect is shown even in the lower red portion. This is one of the few instances in which the red rays are capable of producing any actinic effect. It is no doubt largely due to the colour of the solution, a dirty green, which is able to cut off the red rays as well as to absorb those above.

ACTION OF LIGHT ON URANIC SALTS.

When organic matter is also present, the salts of uranium are chemically affected by light, and, in accordance with what seems to be a general rule, are only influenced by those rays which they are capable of absorbing. Uranium nitrate, for example, which shows absorption bands in the green-blue as a result of spectrum analysis, is affected to a greater extent by these rays than by any others. With the exception, however, of their use for toning and intensification, the compounds of uranium have not been turned to any practical account in photography.

ACTION OF LIGHT ON GOLD COMPOUNDS.

As early as 1737, Hellot noticed a definite effect of light on gold chloride; while Scheele, in 1777, found that the oxide also was sensitive. In 1840 Goddard experimented with a plate of gold sensitised with iodine vapour with encouraging results. Robert Hunt, in 1844, made known the results of a long series of investigations concerning the action of light on various bodies, among which were

several interesting examples obtained with gold chloride and chromate. By exposure to light auric chloride is first converted into aurous chloride, and then into finely divided metal. In the presence of alcohol the equation might be written:—

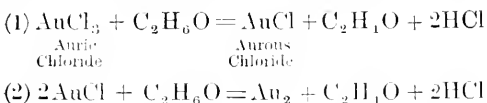

Other investigators have worked in the same direction. The expense of using gold, however, will always operate against its extensive use in photography; but these researches serve to show, at least, that toning baths containing gold should be kept from the light as much as possible, or in dark-coloured bottles.

ACTION OF LIGHT ON MERCURIC SALTS.

Several salts of mercury are affected by light, but in a lesser degree than the substances already considered. Mercurous oxide, Hg_2O , decomposes by exposure to light into mercuric and mercurous oxide, HgO . As far back as the year 1 B.C. Vitruvius referred to the susceptibility to light of mercuric sulphide, otherwise known as cinnabar or vermilion. The chloride, oxalate, and iodide, both mercurous and mercuric; mercurous sulphate, acetate, and tartrate, mercuric bromide, carbonate and citrate, are among the many compounds of mercury which have been experimented with at different times, and have shown more or less susceptibility to light. The nitrate, which formed the subject of investigation by Sir John Herschell in 1840, is also among the number. Mercuric salts in the presence of light are reduced to mercurous compounds. The amount of reduction is increased in the presence of readily oxidisable substances. The following equations illustrate typical reactions:—

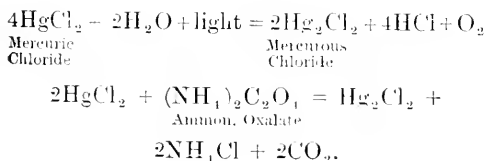

ACTION OF LIGHT ON POTASSIUM BICHROMATE.

If a solution of potassium or ammonium bichromate be poured over a sheet of paper, and then exposed to the light, it turns brown on the exposed portion, the protected portion remaining reddish yellow. Under the influence of the light the organic matter of the paper brings about reduction of the bichromate, and is itself superficially oxidised; hence the brown colour. At the present moment it may be said that comparatively little is certain as to the exact effect of light on chromic salts, except that the presence of organic matter of some kind is necessary. There are two chromates of potassium, the normal yellow chromate, K_2CrO_4 , and the acid orange chromate, or bichromate, $\text{K}_2\text{Cr}_2\text{O}_7$. When the latter is incorporated with a colloid organic substance, such as gelatine, albumen, fish glue, etc., and exposed to light under a negative, two changes take place in the uncovered portions. First, the organic matter is rendered more or less insoluble; and, secondly, it loses its power of absorbing water and swelling or becoming tacky. On the differentiation thus effected between the exposed and unexposed portions of the bichromated film a large number of important photographic processes depend, among which may be mentioned carbon and gum bichromate printing, and the various branches of half-tone, photo-mechanical, and collotype work. According to R. Namias ("Chem. Centr." [2] 868) chromium sulphate $\text{Cr}_2(\text{SO}_4)_3$ is the best compound for rendering the gelatine insoluble, owing to the ease with which the substance undergoes dissociation into Cr_2O_3 and H_2SO_4 . Chromium salts also render albumen and casein insoluble. The tungstates, molybdates, and ceranates can replace potassium bichromate for sensitising gelatine, but are not so active as that compound (T. Baker, "Brit. Jour. Phot.," 1900 [18]).

OTHER SUBSTANCES AFFECTED BY LIGHT

There are many other compounds affected by light, as, for instance, certain salts of lead, manganese, molybdenum,

platinum, cobalt, arsenic, antimony, bismuth, cadmium, rhodium, iridium, tin, and nickel. Under special conditions, phosphorus shows susceptibility to light. Asphaltum, which is much used in the line engraving process, is rendered insoluble

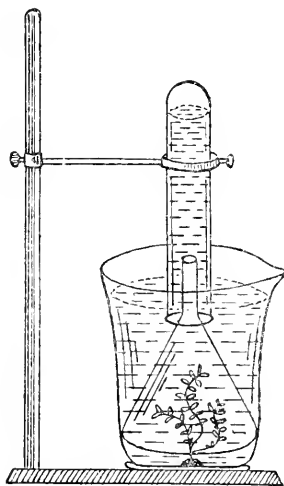

Fig. 557.—EXPERIMENT SHOWING ACTION OF LIGHT ON PLANTS.

by light, and was employed by Niépce in his earliest work (see p. 4); it is rather more sensitive to the red rays than the



Fig. 556.—UNDULATORY WAVES.

majority of compounds, owing to its brownish black colour. Various resins and gums show sensibility. Pliny, in the first century A.D., referred to the bleaching of yellow wax by sunlight. Hog's fat and palm oil also are slightly sensitive. In the organic kingdom there are very few bodies which are not affected by prolonged exposure to light. The action of light in promoting the speedy crystallisation of chemical solutions early attracted attention. The tanning effect of sunlight on the skin, and the marked consequences of its absence in the vegetable and animal

world, are matters of common knowledge. An interesting experiment, showing how the colouring matter contained in the green leaves of plants decomposes carbonic acid under the influence of sunlight, may be performed as follows:—Fill a deep glass beaker (Fig. 557) with water saturated with carbonic acid, and at the bottom place a plant of the common *Anacharis*. Over this is suspended a glass funnel, while an inverted test tube, also filled with similar water, is fixed over the spout of the funnel. If the whole is placed in bright sunlight for a few hours bubbles of oxygen gas will ascend and collect in the test tube.

IDENTITY OF LIGHT AND ELECTRICITY.

Professor Clerk Maxwell, in 1864, laid down the proposition that light and electricity were one and the same thing; that all manifestations of light, radiant heat, and similar phenomena were electromagnetic vibrations of the luminiferous ether travelling in the form of undulatory waves (see Fig. 556). This conclusion has now been endorsed by the scientific world, especially since its experimental demonstration in 1888 by Professor Hertz. Electric waves have been proved to be capable of reflection, refraction, diffraction,

and polarisation in precisely the same way as light waves: although, being of much greater length than the latter, they cannot be seen by the eye. As shown by the Röntgen rays, electricity is capable of affecting the photographic plate in a similar manner to light; conversely, light has the power in various ways of influencing and modifying electrical phenomena. A remarkable illustration of a mechanical effect produced by the action of light is afforded by Crookes' radiometer (Fig. 558), which consists of a glass bulb from which the air is exhausted, and

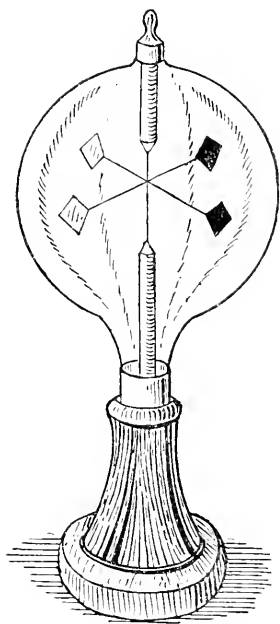

Fig. 55S.—CROOKES' RADIOMETER.

in which are balanced with extreme delicacy four very light vanes, blackened

on one side only. On exposure, the blackened sides of the vanes move away from the light, thus setting up what becomes in sunlight a rapid revolution.

CONCLUDING REMARKS.

It will be seen that exact knowledge regarding the chemical and physical effects produced by light on sensitive compounds is by no means so complete as might be desired. Much still remains to be explained which, at present, is doubtful and obscure. This section has been limited to an inquiry into certain of the most familiar phases of the action of light as affecting photographic practice. The various theories concerning the constitution and nature of the latent image will be dealt with later. In spite of the high level of perfection already attained in photography, so far, at least, as practical work is concerned, the uncertainty which still surrounds so many of its principal operations gives ample scope for experiment; and a still greater degree of success may be looked for, as a result of the more precise knowledge thus gained.

CHEMISTRY OF DEVELOPMENT AND TONING.

THE LATENT IMAGE AND DEVELOPMENT.

COMPOUNDS which render the latent image visible are termed developers. Intimately bound up with the process of development is the constitution of this latent image, and, as already noticed, the views put forward with regard to this problem are, up to the present, simply conjectural. It follows from this that no complete account of the mechanism of development can be given with certainty. But though a connected chain of proof cannot be put forward, many of the accepted explanations are highly probable. The latent image, according to the various theories, consists of layers of varying thickness of either (*a*) subhaloid, (*b*) oxyhaloid, or (*c*) haloid, under varying degrees of molecular strain.

DEVELOPMENT BY MERCURY VAPOUR.

In the old Daguerreotype process, the latent image is rendered visible by submitting it to the action of mercury vapour; the amount of the metal deposited being proportional to the original light intensity. The composition of the compound formed by the mercury, and that constituting the latent image, whether subhaloid, oxyhaloid, etc., is not known, consequently no opinion can be put forward to account for the partiality of the mercury for the latent image, in preference to the unaltered haloid.

ACID DEVELOPMENT (FERROUS SULPHATE).

This developer is used in the wet collodion and other processes, in conjunction with acetic acid. Ferrous sulphate is a very important reducing agent, and in the presence of substances rich in oxygen, such as silver nitrate, it reduces them to a lower state, being itself oxidised to ferric sulphate. This is readily shown by adding a small quantity to a solution of silver nitrate, a black precipitate of metallic silver being instantly produced. The reaction may be expressed as follows:—

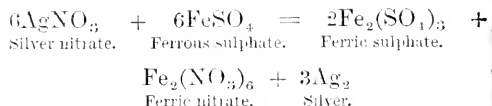

Now try the effect of adding the ferrous sulphate to a small quantity of silver chloride, free from silver nitrate. Under ordinary conditions no reduction is observed in this case.

RESTRAINERS.

On an exposed wet collodion plate there are present the latent image, unaltered haloid, and the sensitiser, silver nitrate. At first sight, a ferrous sulphate developer would appear to be out of place in view of the above reaction, because this silver nitrate should be instantly reduced, all over the plate, to the metallic condition, and so cause general fog. Such would be

the case in the absence of the acetic acid. This acid prevents the developer from acting too rapidly on the silver nitrate. Reagents which bring about this retarding action are termed restrainers. Many substances behave in this manner: for example, soluble organic acids, inorganic acids, and various viscous compounds, such as glycerine, sugar solutions, etc. The acid restrainers exercise this property, by virtue of the fact that they form stable compounds with the silver, and so keep back, for a certain time, the reducing action of the developer. Thus far, then, it will have been noticed that the developer reduces the silver nitrate, the acetic acid preventing this reduction from becoming too rapid, and is without action on the unaltered haloid. Apparently the ferrous sulphate does not reduce the silver composing the latent image (see Meldola, "Chem. of Phot.," p. 162). Where, then, does the silver which is deposited on the latent image come from? Evidently, if the silver of the latent image, and of the unaltered haloid, does not suffer reduction, it must be from the sensitiser, silver nitrate, that the image receives its deposit of metal.

THE FERROUS OXALATE DEVELOPER.

The ferrous salts of certain organic acids, as would be expected, can be utilised for purposes of development. One very important salt of this group, and still largely employed, is ferrous oxalate. This must properly be considered as an acid developer, for, although it *may* be used in a neutral condition, it works best in an acid state, and the formulæ given for this developer almost invariably recommend the addition of an acid, generally sulphuric, citric, or acetic. As ferrous oxalate is practically insoluble in water, it is brought into solution in the form of a double oxalate of iron and potassium. This compound is readily obtained by adding a solution of potassium oxalate to one of ferrous sulphate in the proportions required by the following equation:—

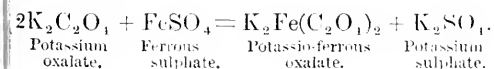

The potassium sulphate produced apparently plays no part in the development. The first action of the developer is on the latent image, which it reduces to the metallic state, being itself at the same time oxidised to ferric oxalate. This latent image silver, then, in the presence of the developer, decomposes the haloid immediately beneath it as before described.

REACTIONS OF FERROUS OXALATE DEVELOPER.

The complete equations representing the reaction taking place will necessarily depend upon the composition of the invisible image. On the sub-salt hypothesis the first equation would be—

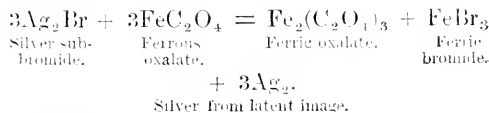

Secondly:—

$2FeBr_3 + 3K_2C_2O_4 = Fe_2(C_2O_4)_3 + 6KBr.$
 This latent image silver, *plus* the haloid beneath, *plus* more developer, produces more silver till sufficient density has been obtained on the negative. On the oxyhaloid hypothesis the first action of the developer would be—

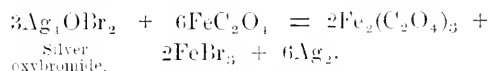

The ferric bromide would then react with the potassium oxalate as above. On the molecular strain view of the invisible image, the first reaction would be—

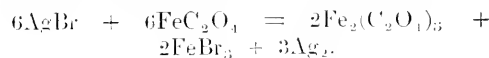

ACTION OF THIOSULPHATE IN FERROUS OXALATE DEVELOPER.

Although it has been known for a considerable time that the presence of a small quantity of sodium thiosulphate increases the activity of a ferrous oxalate developer, and that developer only, the mechanism of the reaction is still very obscure. The thiosulphate not only assists development, but actually decreases

the time of exposure. According to Abney, the period of exposure can be reduced one-third by the use of thiosulphate. The favourable action of this compound is only noticed when it is employed after exposure. If a plate is treated to a preliminary bath of the thiosulphate solution, then exposed and developed with ferrous oxalate, it shows general fog and under exposure. Other compounds besides thiosulphate increase the activity of the ferrous oxalate developer. Sodium sulphite, Na_2SO_3 , is weaker in its effect, and liver of sulphur stronger, than sodium thiosulphate. One explanation of the action of the thiosulphate is, that it probably exercises a solvent effect on the silver haloid, and so brings the developer more into action. According to Meldola ("Chem. of Phot.," p. 158) the increased activity of the ferrous oxalate developer, in the presence of this compound, is due to its reducing action on the ferric oxalate produced during the course of the development.

ALKALINE DEVELOPMENT.

The so-called organic developers, working in alkaline solution, form another important class. Perhaps the most generally useful of this group is an alkaline solution of pyrogallol, tri-hydroxy-benzene, which is so largely used for developing gelatino-bromide or "dry" plates. Pyrogallol not only reduces silver nitrate solutions, but also the haloids of silver. In order to moderate this powerful reducing action, restrainers have to be used, and the most suitable is found to be a soluble bromide: potassium bromide being, as a rule, employed. The restraining action of this salt is probably due to the formation of a stable compound with the silver bromide, which is not so readily acted upon by the developer. If an exposed gelatino-bromide plate is treated with an alkaline solution of potassium pyrogallate a negative is obtained in varying thicknesses of metallic silver.

ORIGIN OF THE REDUCED SILVER.

Attention must be directed to the source of this silver. In the dry plate no

silver nitrate is present, as in the wet collodion process, consequently the metal must come either from the unaltered haloid or from the latent image. If its source is the unaltered haloid, the only manner in which it can be deposited on the latent image is by the former dissolving in the alkali and then undergoing reduction by the developer, as described in the case of silver nitrate. If, however, unexposed silver bromide is repeatedly washed with a solution of ammonia, potash, or soda, of the same strength as that used in development, it is found that only the merest trace of the haloid is dissolved, quite insufficient to account for the density of the silver deposit on the negative. Evidently, therefore, this deposit must have its origin in the invisible image.

EXPLANATION OF DENSITY.

Now, it has been proved that the change brought about by the action of light on a sensitive film is of an extremely minute character, and its equivalent in metallic silver would likewise be exceedingly small. To account for the density of a negative, then, further investigation has to be made. Towards this end, the following experiments appear to offer a clear explanation. Abney exposed a dry plate, and then covered half of it with a collodio-bromide emulsion. The plate was next developed and the two films separated. On examining these an image was found on each. The only way of accounting for the image on the collodion film, which had not been exposed to light, is by assuming that the exposed haloid on the gelatine film is first reduced by the developer, then this liberated silver, together with more developer, sets up a decomposition of the silver haloid immediately above it. This second layer of metal, *plus* more developer, then reduces another layer of haloid, and so on, till no more haloid is available. The same action takes place under the reduced image on the gelatine plate, and extends downwards. In an experiment of Dr. Eder a very thick gelatino-bromide emulsion was exposed and then developed. In this case the metallic silver of the image extended right through

the thickness of the film, and is clearly formed from the haloid immediately below the latent image.

DIFFERENCE BETWEEN ACID AND ALKALINE DEVELOPMENT.

Acid development, such as that described under ferrous sulphate, differs in a marked manner from alkaline development, especially in the way in which the image on the plate is obtained. In the first method the image receives its silver from the sensitiser, silver nitrate, which is deposited on the plate and grows upward, without the haloid beneath undergoing decomposition. In alkaline development no extra silver is added to the plate, the haloid is the source of silver, and the image grows downward. This difference

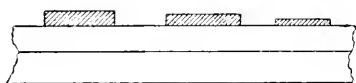

Fig. 559.—ACID DEVELOPMENT.

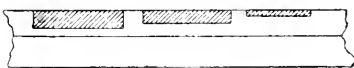

Fig. 560.—ALKALI DEVELOPMENT.

in the nature of the image, is shown by treating negatives obtained by the two methods, with dilute nitric acid. The negative from the acid developer is simply restored to its previous condition, whilst that from the alkaline developer has its gelatine surface pitted in places where the image originally rested (see Fig. 560).

GROWTH OF THE SILVER IMAGE.

It is very remarkable that the silver from the latent image, under the influence of the developer, should reduce the silver haloid just beneath or the silver nitrate above. It is extremely probable that the action referred to is one of electrolysis. In fact, the experiments of Abney and Eder quoted above almost demonstrate electrolytic action. Each minute particle of reduced silver from the latent image can be looked upon as constituting the electrodes of an enormous number of minute cells, each electrolytically decomposing the haloid, or silver nitrate, in its immediate neighbourhood, and depositing the silver. Lermontoff's experiment prac-

tically demonstrates this electrolytic behaviour of the silver. A solution of ferrous sulphate is separated by a porous diaphragm from a solution of silver nitrate. A thin piece of silver is then bent so that one end dips in the iron and the other in the silver solution (Meldola, "Chem. of Phot.," p. 180). In a very short time a crystalline growth of silver makes its appearance on that part of the metal in the silver nitrate.

NEUTRAL DEVELOPMENT.

Besides the two classes of developers already considered—those which are used in an acid state, and those employed with an alkali or alkaline salt—there is a third class which cannot be included under either heading. Amidol, dianine (di-

amido-resorein hydrochlorate), and tri-amido-phenol, for instance, may be used with sodium sulphite as developers without any alkali. Adurol may be used with water only, although it then becomes inconveniently slow. Synthol can be employed, with sodium sulphite, either with or without alkali. In addition to these, there are several other less known developing agents which are capable of successful employment in the absence of alkali, and must consequently be considered as neutral. The potassium oxalate solution employed for the reduction of the image in the platinotype process may also be regarded as a neutral developer. It is possible to use eikonogen without an alkali, but this is seldom or never done.

RELAPSE AND DESTRUCTION OF LATENT IMAGE.

It is a curious and rather perplexing fact that after the expiration of a certain length of time—some years in the case of a gelatine film—the invisible image dis-

appears. This phenomenon is explained, on the sub-haloid and oxyhaloid hypotheses, by assuming that the liberated halogen, resulting from the formation of these compounds, is absorbed by the sensitiser, and is then slowly re-absorbed by the latent image, in this manner reverting to its original state. According to the molecular strain theory, the relapse or recovery of the invisible image is of a purely physical nature; the energy, absorbed by the molecules of haloid and sensitiser, from the original light action gradually disappears. The molecules may be compared to minute secondary batteries, consisting of stored energy, which, when completely run down, are then in the same condition as unexposed molecules of the silver haloid. Now it has been found that not only does the latent image return to its original molecular condition by itself, but that oxidising agents and the halogens cause a like change.

HALOGEN ABSORPTION.

One explanation of the cause of the destructive action of these compounds on the latent image is that it is due to the gradual oxidation and re-halogenisation (or halogen absorption) of the sub-haloid or oxy-chloride. If this is so, it is simply a good illustration of a reversible reaction. From a chemical point of view this is an extremely probable explanation, if the action of the light is to decompose the silver haloid, because practically all chemical changes under the proper conditions can be reversed.

MOLECULAR DISTURBANCE THEORY.

If the change on an exposed film is merely a case of energy absorption for the time being, this rehalogenisation or oxidation hypothesis is inadequate. On the physical view of the invisible image, the addition of the destructive agent may result in a molecular disturbance, or proceed further, and be accompanied by a chemical change of the sensitiser. For instance, in the case of the latent image on a Daguerreotype plate this is instantly destroyed, if treated to the vapours of a

halogen. In this instance the excess of halogen simply disturbs the molecular condition of the altered haloid, and discharges its absorbed energy, thereby converting it to the original haloid. An exposed gelatino-bromide plate loses its invisible image on treatment with oxidising agents such as nitric acid, chromates, permanganates, etc. Now it is a well-known fact that gelatine is susceptible to the action of oxidising agents, such as, for example, potassium bichromate. Hence it is very probable that the oxidising agent first attacks the sensitiser, that is the gelatine, producing a micro-chemical change, and the molecular change engendered thereby, sets up a corresponding disturbance, of an opposite kind to that produced by the light originally, thus causing the altered haloid to revert to its former condition.

REVERSAL BY LIGHT ACTION.

The continued action of the light on a sensitive film also results in the partial or complete destruction of the latent image. This phenomenon is known under the name of solarisation or reversal. For instance, a greatly over-exposed film, on development, produces a positive instead of a negative. It has been shown by numerous investigators that the latent image behaves in a most peculiar manner under prolonged exposure. Up to a certain point it gradually gains in intensity and then slowly disappears. It again reaches a certain degree of intensity, gradually diminishing a second time, and so on. In this connection, the following facts, due for the most part to Abney, are interesting: Solarisation is facilitated by a preliminary exposure to diffused daylight, by the action of powerful developing solutions, and by treating the plate with a solution of some oxidising agent before exposure. According to Abney, atmospheric oxidation is essential in producing solarisation.

DIFFICULTY OF EXPLAINING REVERSAL.

It must be confessed that it is extremely difficult to attempt to explain, from either a chemical or physical point of view, the

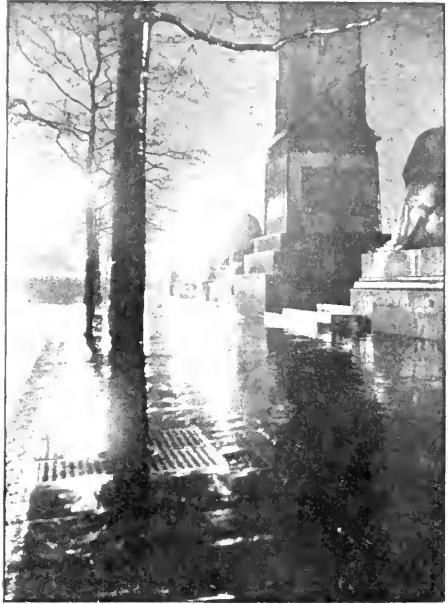

STEREOSCOPIC NIGHT PHOTOGRAPHY

various facts underlying reversal. It is very probable that the prolonged exposure necessary to produce solarisation is more photo-chemical in its behaviour than physical. It is only necessary to consider the possibility of having on a plate, in less than microscopic quantities, unaltered silver haloid, reduced silver haloid (subhaloid or oxyhaloid, or a combination of the two), silver haloid under molecular tension, gelatine partly oxidised, partly halogenised, and partly under molecular tension, to see how very complicated the subject becomes. In the present state of photo-chemical knowledge the so-called explanations are of a purely speculative character.

EXPERIMENT WITH MERCURIC CHLORIDE.

In connection with this subject of the destruction of the latent image, the following experiment of Reiss ("Chem. Zeit." 26 [40]) is interesting. He utilised the well-known destructive action of mercuric chloride on the invisible image to render exposed plates fit for a second exposure. The exposed plate, containing the image to be destroyed, is first treated with a solution of 5 per cent. mercuric chloride and then well washed. It is next quickly immersed in an anidol developer, which seems to facilitate the action of the light in the second exposure, dipped in water, and then exposed while wet. The exposure takes from about 100 to 150 times that of the first, and a much longer development, to produce the second latent image. It is rather curious that no fog results. The negatives obtained are well covered in the lights, but are perfectly clear in the shadows. Apparently the action of the mercuric chloride on the latent image induces a far greater change than that involved in merely converting it to its original condition.

REDUCTION.

In some cases the negative, after development, is too dense and takes a very long time to print. This defect can be remedied by submitting it to reagents which will remove some of its silver, the process being termed one of photographic reduction. Ammonium persulphate is a

substance capable of acting as a reducer, and has already been noticed in the section on Reduction of Negatives

FERRIC CHLORIDE REDUCER.

By immersing a negative in a solution of ferric chloride the iron is converted into the ferrous condition, and some of the silver, on the negative, into chloride, the equation being as follows:—

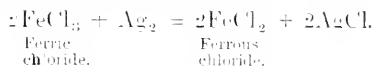

If a solvent for silver chloride, such as sodium thiosulphate, be now added, it dissolves, and thereby weakens the original deposit. This method of reduction is not a good one for two reasons. In the first place the operator is unable to follow the course of the reaction, as the amount of reduction is only observable after the silver has been removed by the thiosulphate. Secondly, the ferric chloride is continually oxidising the thiosulphate, which is also a disturbing factor.

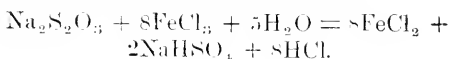

EDER'S PROCESS.

In Eder's process the silver is removed in the form of oxalate. A solution of potassio-ferric oxalate and sodium thiosulphate is added to the negative. The metallic silver reduces the ferric oxalate to ferrous oxalate, forming at the same time silver oxalate, which dissolves at once in the thiosulphate. In this way the photographer actually sees how much silver is being removed from the negative undergoing reduction while the reaction is going on. The change may be shown as follows:—

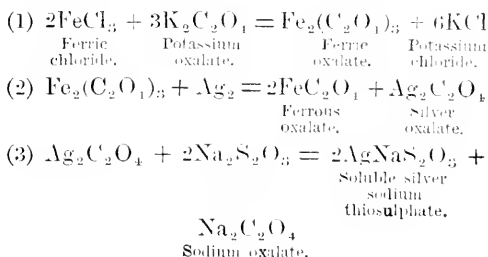

THE FERRICYANIDE REDUCER.

In Howard Farmer's process a freshly-made solution of potassium ferricyanide and sodium thiosulphate is used for reduction. By this method the silver is slowly converted into ferrocyanide, and it is very probable that small quantities of the ferricyanide are formed at the same time. Both compounds, however, dissolve at once in the sodium thiosulphate, thus allowing the amount of reduction to be observed. The reactions taking place may be expressed by the following equations:—

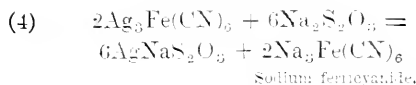
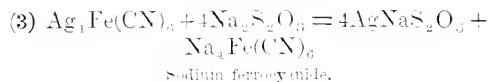
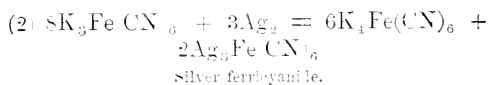
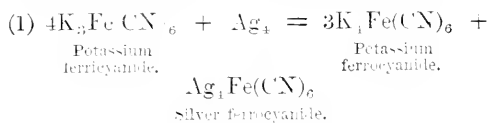

REMOVAL OF GREEN FOG.

Henderson has shown that green fog can be removed, or an overdense negative reduced, by placing it over a fairly strong solution of potassium cyanide for several hours. The action in this case, is probably due to the carbon dioxide decomposing the easily ionised cyanide, thus liberating HCN, which forms easily soluble AgH(CN)₂.

INTENSIFICATION.

Intensification is, of course, the opposite to reduction. Extra material is added to a weak negative, in order to increase its density. In most cases the silver image is first bleached by immersion in mercuric chloride solution. This bleaching is due to the formation of a mixture of silver and mercurous chloride, thus:—

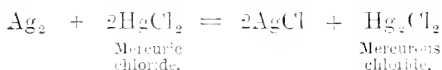

As this whitened image is hardly opaque enough for printing, it is darkened either by treating with ammonia, ammonium sulphide, sodium sulphite, or with a ferrous oxalate developer.

THE BLACKENING ACTION OF AMMONIA.

A dilute solution of ammonia blackens the image, probably by the formation of complicated mercurous and silver derivatives of ammonium chloride; the two chief compounds being NH₂Hg₂Cl and NHAgHg₂Cl.

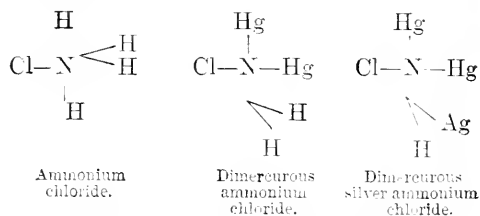

From some recent investigations of M. F. Leteur the black compound, on analysis, contains silver, and these experiments confirm the formula NHAgHg₂Cl proposed by Chapman Jones. The equation showing the change would then be—

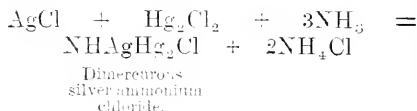

In the case of using ammonium sulphide the metals forming the bleached image are converted into sulphides.

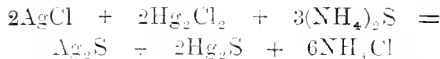

INTENSIFICATION WITH SODIUM SULPHITE.

Intensification by means of sodium sulphite results in the partial dissolving of the chlorides on the film as complicated sulphites, the rest being reduced, for the most part, to the metallic state.

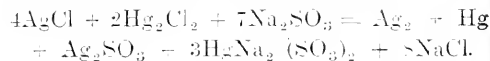

According to G. Hauberrisser ("Phot. Rundschau," 1952 [16] 45) sodium thiosulphate solutions remove from the intensi-

fed negative silver and mercury, leaving a black residue. On treatment with acid, large amounts of sulphuretted hydrogen were produced. He concludes by saying that the negative intensified by sulphite and mercuric chloride probably consists of mercury and silver in union with a small quantity of sulphur. But according to E. Valenta ("Phot. Corr." 1902 [6] 10) the blackened image contains no compound of silver or mercury in combination with sulphur. If a sufficient amount of sulphite is used, it consists entirely of metallic silver and mercury. With a weak solution of sulphite, or if a concentrated solution of sulphite is used for a short time, the blackened image consists of varying amounts of silver chloride, plus metallic silver and mercury.

INTENSIFICATION WITH FERROUS OXALATE.

According to Chapman Jones ("Roy. Phot. Soc. Jour.," 1897) the most reliable method of intensification is by the use of the ferrous oxalate developer on the bleached image. The developer reduces the chlorides to the metallic state, the increased density being due to the deposition of mercury.

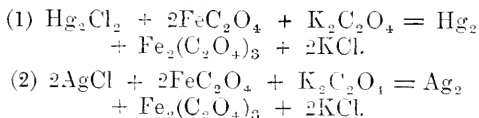

If the negative has not sufficiently gained in intensity, it can be put through the bleaching and developing process again, so as to deposit more mercury on the film. This metal apparently forms a stable amalgam with the silver, owing to the protective action of the gelatine.

LEAD AND URANIUM INTENSIFIERS.

Another method of intensification consists in the use of certain metallic ferri-cyanides, the more common being those of lead and uranium. The principle of these intensifiers is the formation of an insoluble ferrocyanide of the metal, by the reducing action of the silver on its ferri-cyanide. If the negative is treated with lead ferri-cyanide, obtained by adding lead

nitrate to potassium ferri-cyanide, it becomes coated with a greyish deposit consisting of silver and lead ferrocyanides. The changes taking place may be represented as follows:—

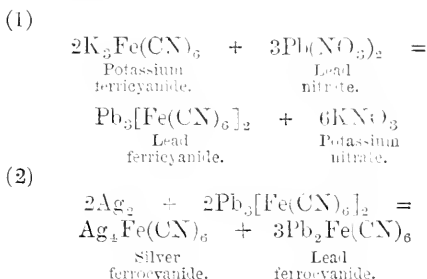

The mixture of ferrocyanides is then treated with ammonium sulphide or potassium chromate, forming the sulphides and chromates of silver and lead respectively, in order to render the negative more suitable for printing purposes.

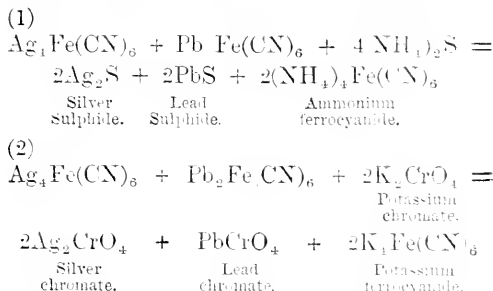

In the case of the uranium intensifier, the mixture of silver and uranium ferri-cyanides, being dark brown in colour, is sufficiently opaque. A probable equation to express the change is as follows:—

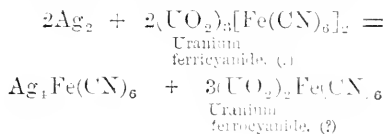

ALBUMENISED PAPER.

This is prepared by coating paper with albumen containing ammonium chloride. The salted paper is sensitised as required by floating on a solution of silver nitrate. Evidently the paper now contains silver chloride, intimately mixed with the albumen, due to the interaction of the

ammonium chloride and silver nitrate:



Another reaction also takes place between the albumen and the silver nitrate, to produce an insoluble compound of silver and albumen, whose nature is not known. This is usually termed "silver albuminate." That this is the case, is easily shown by adding silver nitrate solution to a solution of albumen in water. The compound is thrown down as a white curdy precipitate. The sensitive surface of albumen paper consists of silver chloride and silver albuminate, together with a small quantity of silver nitrate. In the ready sensitised paper citric acid is present as well.

ACTION OF LIGHT ON ALBUMENISED PAPER.

Now this is a truly formidable list of compounds to have together, and in the present state of knowledge very little is known of the changes brought about in them by the action of light. In the first place, the constitution of albumen is unknown, and it is very questionable whether the formula given in the text books is true. Secondly, the composition of the albuminate is unknown, and it is idle to speculate about its photo-decomposition. Thirdly, the light decomposition of silver chloride is extremely vague, especially in the presence of organic matter. The reddish brown reduction compounds, produced by the light's action on the albumen paper, may be identical with the photo-salts of Carey Lea (see p. 408). They would thus consist of a series of reduced compounds, from metallic silver to the unaltered product. Perhaps the first action of the light is to set up an internal strain on the molecules composing the sensitive surface.

ACTION OF LIGHT ON COLLODIO- AND GELATINO-CHLORIDE PAPERS.

In the "printing-out" papers, collodio and gelatino emulsions of silver chloride and citrate are used. The action of light on these, as in the case of albumen paper,

is allowed to continue to the period of visible decomposition. The remarks made above, in connection with the chemical changes taking place when printing with albumen paper, apply also to these various printing-out papers: that is to say, practically nothing is known.

CHEMISTRY OF BROMIDE PRINTING.

Bromide paper is a paper covered with a gelatino-bromide of silver emulsion, similar to that used for coating dry plates, but much slower. In this case an exposure is made behind the negative, but the image is invisible. This is then developed with hydroquinone, ferrous oxalate, or almost any other developer. The chemistry underlying the process is identical with ordinary development, and it follows that the picture is composed of metallic silver.

PRINTING IN PLATINUM.

Platinum prints are not secured by the direct photo-reduction of platinum salts. Instead, they are obtained indirectly through the photo-reduction of ferric oxalate. It has been noticed already that ferric oxalate, in the presence of light, is converted into ferrous oxalate. In the preparation of "blue" prints, this ferrous compound is treated with potassium ferricyanide, thus producing Turnbull's blue. In the platinotype process, the ferrous oxalate is made to reduce a platinum salt to the metallic state. In the actual process a paper is covered with ferric oxalate and potassium chloroplatinite. It is then exposed, whereby the ferric compound is reduced to ferrous oxalate, the platinum compound remaining unaltered. It is next treated with a warm solution of potassium oxalate. As soon as the ferrous oxalate dissolves in the potassium oxalate, it reacts with the potassium chloroplatinite, and reduces it to metallic platinum. The reaction taking place may be written:—

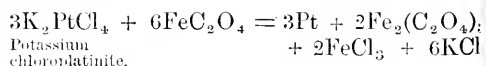

By sensitising the platinum paper with mercuric citrate, obtained by adding mer

curic oxide to citric acid, tones varying from yellow, black, brown, to red brown are obtained with a cold developer (Hübl, "Chem. Zeit.," 25 [100] 360).

TONING.

To remove the objectionable red brown colour of the freshly printed albumen or gelatino-chloride paper, it undergoes the operation of toning. As a rule, this consists of the deposition of some metal on the silver and reduction products obtained in the printing.

GOLD TONING.

In gold toning a solution of gold chloride, AuCl_3 , or sodium chlor-aurate, NaAuCl_4 , is used in a neutral solution, or in the presence of some mild organic acid. The substances usually employed are, ammonium sulphocyanide, sodium carbonate, acetate, borate (borax), phosphate or tungstate. The silver and the brown-red reduction products on the paper first of all reduce the auric chloride to aurous chloride, and then this compound to the metallic state. The colour of the precipitated gold depends upon the rate of deposition, the strength of the toning bath, and the temperature of the solutions. The operation of toning is probably electrolytic in its action, if much silver is present in the print.

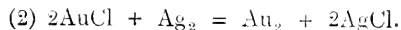
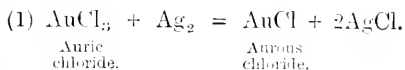

In the fixing bath the thiosulphate removes this silver chloride and any not affected by the light originally. The precise action of the thiosulphate has, however, already been dealt with.

TONING WITH PLATINUM AND LEAD.

In platinum and lead toning an exactly similar set of reactions are produced as in the case of toning with gold. For instance, the platinum is reduced from the platinumic to the platinumous state, and then deposited as the metal

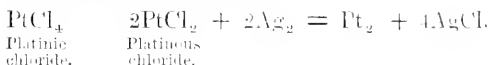

or



In the case of a lead compound, metallic lead takes the place of the silver.

URANIUM TONING.

Bromide prints are sometimes toned with uranium compounds, as already mentioned under Intensification. A chocolate deposit is produced, consisting of silver and uranium ferrocyanides. From what has been said already, many other processes could also be used for changing the colour of a bromide print. Gaedecke considers that the permanence of bromide prints, toned by the formation of certain metallic ferrocyanides, is of a very doubtful nature. The red and blue tones obtained by uranium nitrate and ferric oxalate respectively are not to be trusted, as regards permanency.

THEORY OF THE LATENT IMAGE.

INTRODUCTORY REMARKS.

THE changes which substances undergo under the influence of light may be divided into two kinds: those of a physical and those of a chemical nature. A few examples of a change in physical properties might be noted. For instance, powdered non-crystalline selenium (an element very similar to sulphur) gradually becomes crystalline when exposed to light. Under ordinary conditions, in the dark, this crystalline variety of selenium is a very poor conductor of electricity, but under the influence of light it becomes a conductor. Again, ordinary yellow phosphorus, a highly inflammable substance, is gradually converted by the prolonged action of light into red phosphorus, having very different properties from the yellow variety. In these two examples no chemical change has taken place, non-crystalline and crystalline selenium are identical in chemical properties, and the same is true of the red and yellow phosphorus. The change in physical properties can only be explained by assuming that the light has influenced the molecular condition of the substance on which it has acted. Hence one important action of light is to bring about a molecular change.

CHEMICAL CHANGES DUE TO LIGHT.

Eder ("Handbuch der Photographie,") makes the following generalisations:—

(1.) All kinds of light from the infra red to the ultra violet are capable of some sort of photo-chemical action.

(2.) Photo-chemical action is only produced by such rays as the illuminated body absorbs, so that the chemical action of light is closely associated with the optical absorption.

(3.) The sensitiveness of a body towards rays of a definite refrangibility is increased by the admixture of other substances which absorb the same rays.

(4.) A substance is, as a rule, decomposed faster by a given colour when it is mixed with a body which absorbs one of the products resulting from the photo-chemical decompositions such as oxygen or the halogens. From the first generalisation, it is evident that it is not correct to suppose that violet light alone is chemically active. For instance, hydrogen sulphide solution is decomposed more quickly by red light than by the violet rays. The yellow rays of sunlight are the most active in producing the photo-decomposition of carbon di-oxide by the green parts of plants. Another point to be noticed is that light may bring about the union or disruption of two or more elements. A mixture of hydrogen and chlorine exposed to light combines with explosive violence to form hydrochloric acid.



But this equation does not correctly explain the reaction, because if the two gases are *dry* it is extremely difficult to make them combine. Hence the presence of moisture is essential to induce the reaction. Potassium iodide in the dry condition is a stable substance, but if damp and exposed to light it gradually darkens and becomes alkaline. This change may be represented as follows:—



The action of light is partly oxidising and partly reducing, according to the nature of the substance under its influence. Red light acts mostly as an oxidising agent on metallic compounds, and violet light as a reducing agent.

PHOTO-CHEMICAL EXTINCTION.

Rays which have passed through a medium sensitive to light are weakened in their chemical activity; in fact, if the medium is of sufficient thickness, their chemical activity may be de-

stroyed entirely. This phenomenon is termed "photo-chemical extinction," and is apparently of very frequent occurrence. From this it follows that light which is chemically active performs a certain amount of work.

PHOTO-CHEMISTRY OF THE SILVER COMPOUNDS.

The action of light on the compounds of silver is by far the most important phenomenon in photography. All the compounds of silver, both organic and inorganic, are affected by light rays. The first recorded observation of the darkening of a silver salt by the action of light was apparently made by Johann Heinrich Schulze, of Halle, in 1727. Silver chloride when exposed to the light turns violet, and under continued exposure a brownish violet colour. On prolonged exposure to light this salt slowly undergoes decomposition and evolves chlorine. These, and many closely similar phenomena, are, however, fully treated in the section dealing with the Chemical Action of Light.

THE LATENT IMAGE.

There are various views put forward to explain the change brought about on the surface of an exposed photographic plate. Such a plate shows absolutely no difference in appearance from one which has not received a preliminary light treatment. Nor is any loss of weight detected even by the most sensitive chemical balance; yet a change has taken place under the influence of light, because a marked difference is observed when the plate is submitted to the action of a developer. The imperceptible yet important change produced is termed the "latent" or invisible image. So far, then, the following facts are known with certainty:—

1. Light, in some cases, brings about a molecular change of a purely physical nature, and in others chemical decomposition.
2. Silver chloride on prolonged treatment with light (*a*) darkens, and (*b*) decomposes with the evolution of chlorine. The composition and formula of the residue is not known. It evidently contains a higher percentage of silver than the normal haloid.
3. The latent image is (*a*) produced by a very short exposure; (*b*) is invisible; and (*c*) there is no loss of weight.

THE THEORY OF SUB-SALTS.

In order to explain the formation of the latent image on an exposed plate, various "theories" have been proposed from time to time. One which has received a great amount of favour is known as the Theory of Sub-salts. According to this idea, when light acts upon a compound of silver it removes a portion of the non-metallic element, and so increases the percentage of silver, and the new compound produced is termed the "sub-salt." Thus the action of light on silver chloride would be represented in this manner:—

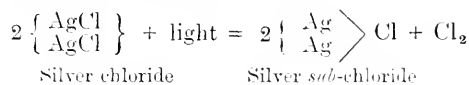

The greater the intensity of the light, the more is this sub-salt formed; and on this supposition the latent image would consist of layers of silver sub-chloride of varying thicknesses. This sub-salt theory was originally proposed by Fischer in 1814, and was stated very clearly by Wetzlar in 1834. The theory is in harmony with the observed fact that light liberates chlorine from silver chloride. It also explains why the developer attacks the exposed portion of the plate in preference to the unexposed part, because the sub-chloride is already half reduced to the metallic state. The fact that no change of colour is observed on the exposed plate is accounted for, because of the extremely minute amount of sub-salt produced. Also, no loss in weight would be detected, because any liberated halogen is absorbed by the gelatine on the dry plate, or by the silver nitrate on the wet plate.

EXISTENCE OF SUB-SALTS DOUBTFUL.

The evidence for and against the idea that the latent image consists of silver sub-haloid may now be examined. According to Wetzlar (Schweig's "Jahrbuch," 1828), he obtained small quantities of silver sub-chloride by treating solutions of ferric and cupric chloride with silver leaf. In 1839 Wöhler passed a current of hydrogen over silver citrate heated to 100°C. On analysing the residue, a compound having the formula Ag_4O was said to be present. This Ag_4O would be silver suboxide and would correspond to the sub-chloride Ag_2Cl . Von Bibra ("Journal für Prak. Chem.," [2] 12-55) treated

Wöhler's suboxide with strong hydrochloric acid for some time, and isolated a body having the formula Ag_4Cl_3 . If this is the formula for the sub-chloride it contains a greater percentage of silver than that represented by Ag_2Cl . Many chemists have repeated the work of Wöhler and Von Bibra, and have come to the conclusion, that the existence of these salts is extremely doubtful. Güntz says that silver sub-chloride, Ag_2Cl , is obtained by treating sub-fluoride, Ag_2F , with strong hydrochloric acid. He obtained the sub-fluoride by passing a powerful current of electricity through a concentrated solution of silver fluoride, using silver electrodes. Up to the present, the formula of this sub-fluoride has not been established. Otto Vogel ("Phot. Mitt." [36] 334) attempted to isolate these silver sub-haloids by allowing cuprous chloride, bromide, and iodide to act upon a solution of silver nitrate. On a cupric salt silver nitrate acts as under:—



With a cuprous salt the reaction is expressed by Vogel as,

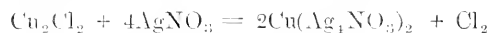

The three sub-haloids were stable in the air and only very slightly acted upon by the light. The analytical results agreed with the formulae Ag_2Cl_2 , Ag_2Br_2 , and Ag_2I_2 . Vogel finds that mercury does not extract silver from these sub-haloids. Under the microscope complete homogeneity is observed. Nitric acid attacks the compounds, dissolving silver and leaving the ordinary haloids, AgCl , AgBr , and AgI . Vogel explains the fact, that silver chloride and bromide are not decomposed by nitric acid when exposed to light (which should be the case if they are converted into sub-haloids), by assuming that the sub-haloid at once combines with the ordinary haloid of silver, to form a stable substance. Waterhouse ("Photo. Jour." 1900) and Emszl ("Zeits. Anorg. Chem.") repeated Vogel's experiments, and came to the conclusion that sub-haloids are not produced in this manner. From their investigations it appears that Vogel's compounds consist of intimate mixtures of finely divided silver and unaltered haloid. The latent image cannot consist of reduced silver and unaltered haloid, as some have suggested, since silver chloride darkens under nitric acid, and on examining the acid no

appreciable amount of silver is found. If the metal were produced by the light action, it would be removed as fast as formed, and the acid would contain silver nitrate.

THE "PHOTO SALTS" OF CAREY LEA.

By treating ammoniacal solutions of silver chloride with ferrous sulphate, washing the resulting precipitate, and then treating with hydrochloric acid, various coloured compounds are obtained, containing less halogen than the original chloride. These substances were termed "photo salts" by their discoverer, Carey Lea ("Amer. Jour. Science," 1887), as he considered them identical with the compounds produced by the action of light on the silver haloids. Their method of formation suggests the possibility of sub-salts existing in admixture with the ordinary haloid. So far no chemical formula can be assigned with certainty to these "photo salts."

THE OXY-CHLORIDE THEORY.

Many chemists who have turned their attention to photography hold the view that the balance of evidence is against the idea that the latent image is due to the formation of sub-salts. In their opinion, the latent image consists of varying thicknesses of silver oxy-chloride, oxy-bromide, or oxy-iodide. The silver haloid, according to this view, in the presence of light or oxygen, or water vapour, slowly loses a portion of its halogen and absorbs oxygen, to produce what is termed an oxy-haloid. Dr. Hodgkinson examined the darkened product, and as the result of his analysis gave it the formula $\text{Ag}_2^{\text{O}}\text{OCl}_2$ ("Chem. of Photog.," page 56). Baker also found that the darkened silver chloride contained oxygen, and assigned to it the formula Ag_2OCl . Representing the action of light on silver chloride, according to this view of the change, the equations would be:—

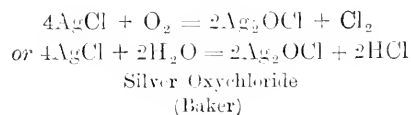
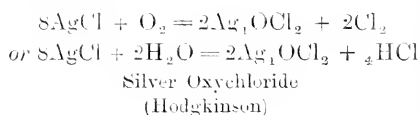

FACTS BEARING ON OXYCHLORIDE THEORY.

With regard to the formation of this oxychloride the following facts are interesting:—Abney found that silver chloride did not darken in a vacuum, even after the expiration of several months, provided it was thoroughly dry. From this experiment it appears that oxygen and water vapour are necessary. Carey Lea mentions that the chloride does not darken in thoroughly dry air or oxygen. This would make it appear that it is not the oxygen which causes the compound to darken, but the pre-

prolonged treatment undergoes chemical decomposition: but their contention is, that the duration of the action of the light in an ordinary photographic exposure is insufficient to decompose the silver haloid. For instance, Chapman Jones ("Science and Pract. of Phot.," 1895, page 169) believes that all the facts agree with the supposition that the developable image, that is latent image, consists of particles of silver salt rendered less stable, but not decomposed. Again, Lüppo Cramer ("Brit. Jour. Phot." [49], 1902) is of the opinion that, in the present position of our knowledge, there

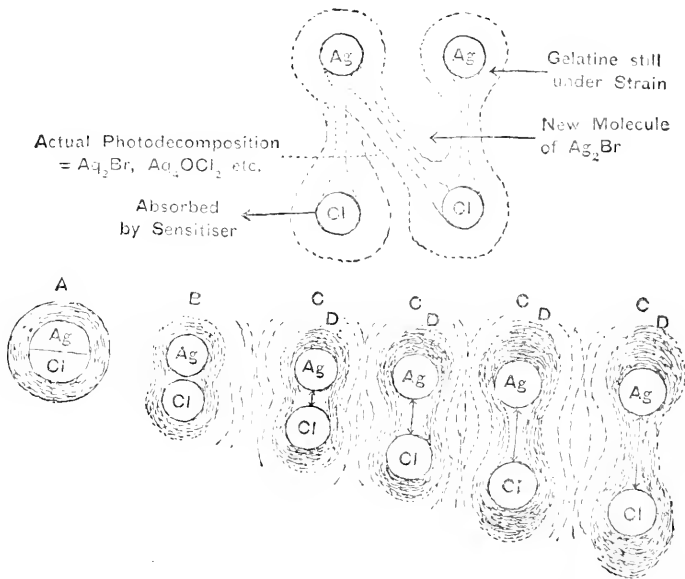

Fig. 561.—DIAGRAMMATIC VIEW OF MOLECULAR STRAIN HYPOTHESIS.

sence of moisture. He also states, however, that silver chloride darkens under perfectly dry petroleum. As no moisture or air is present in this case, it is difficult to see how any oxychloride is formed. The same may be said of an experiment of Baker, who found that silver chloride darkened under dry benzene, and showed that the dark substance was metallic silver. These last two experiments, however, are not incompatible with the idea of sub-salts.

MOLECULAR STRAIN THEORY.

Many are of the opinion that when light acts upon a silver haloid to produce the invisible or latent image, no chemical change takes place. They do not deny that silver chloride on

is a complete absence of proof that *normal* photographic exposure produces any chemical change in silver bromide. To account for the formation of the latent image, it is supposed that when a silver haloid is affected by light, an internal strain is set up in the molecules, and that the amount of strain is proportional to the light intensity. A similar strain would also be produced in the sensitiser present. The effect of the molecular strain is to render the compound less stable, so that in the presence of a reducing agent (a developer), molecules under the greatest strain are the first to be smudged, and so produce metallic silver. If the action of the light is prolonged, the strain becomes so great that the molecule is

broken down with the liberation of the halogen, and the production of the sub-haloid or oxy-chloride, or some other reduction product. (See Fig. 561 for rough diagrammatic idea of theory.)

RELAPSE OF IMAGE.

This molecular strain theory also accounts for the relapse of the latent image. The recovery of all latent images is only a question of time. With some substances there is an immediate recovery as soon as the light is removed; with others it takes longer, as in the Daguerreotype, where the latent image disappears after the expiration of some hours. In the ordinary photographic plates recovery only happens after the lapse of several years. One of the chief functions of the so-called sensitisers may be to prevent the self-recovery of the molecule under strain, and to make the effect permanent. The following interesting facts may be noted in connection with this idea of molecular strain:—Prof. Dewar ("Proc. Roy. Inst.," vol. 13, p. 695) found that chemical activity gradually decreased as the temperature was lowered. At a temperature of -180° C. a highly active substance like potassium does not show any appreciable action when immersed in liquid oxygen. By reducing the temperature to -200° C. it was found that an ordinary photographic plate was still fairly sensitive to light. Now it is rather difficult to see why light should produce a chemical change, such as a sub-salt or oxy-chloride, on the relatively chemically inactive silver haloid, and yet at a temperature twenty degrees higher no chemical change is obtained with the highly chemically active potassium and oxygen. It seems more reasonable to suppose that the light's action was a purely physical one.

FURTHER EXPERIMENTAL RESEARCHES.

Major General Waterhouse ("Proc. Roy. Soc., 1909") confirmed Moser's experiments, that invisible images are formed on pure silver or copper plates when exposed to the light. A plate of pure silver was exposed under a masked pattern to the action of sunlight for two hours. It was then held over mercury vapour, and a distinct image of the mask was obtained. (See p. 389.) Copper behaved in a similar manner. Consequently, these experiments indicate that most of the phenomena produced

in the exposure of an ordinary photographic plate, containing on its surface silver haloids, can be observed upon a plain plate of silver exposed to the light in the air under ordinary conditions. A printed-out image on a thin film of silver was treated with a solution of potassium cyanide. The unexposed parts wrinkled, but not the exposed parts. These experiments appear to be best explained by assuming that a physical and not a chemical change has taken place under the light's action. The uncertainty with regard to the correct composition of the latent image is due to the great experimental difficulty met with, in studying the problem, of isolating the extremely minute amount of changed haloid, from the large amount of unchanged salt.

RIPENING OF EMULSIONS.

The sensitiveness of the silver haloids to light depends very much upon their physical condition. When silver bromide is precipitated in the collodion emulsion, a certain amount of time elapses before it reaches its maximum degree of sensitiveness, and in order to attain this it is allowed to stand for some time; this process is termed the "ripening" of the emulsion. The haloids in the gelatine emulsion, when just precipitated, are in about the same degree of sensitiveness as those present in the collodion emulsion. But if the gelatine emulsion is heated in a water bath, it then becomes much more sensitive than the collodion emulsion. It has also been found that the emulsion may be "ripened" by heating it with ammonia for a short time. All these ripening processes bring about an increased size of the particles of silver haloid. Freshly precipitated silver bromide particles were measured by Eder, and found to be from $\cdot 0008$ to $\cdot 0015$ of a millimetre in diameter. After being "ripened" they had increased to $\cdot 003$ and $\cdot 004$ of a millimetre in diameter. There is, however, a limit to all ripening processes, as it is found that the silver haloids attack the gelatine after a certain time, and become partially reduced. Plates covered with an over-ripened gelatine emulsion exhibit general fog when immersed in the developer.

SENSITISERS.

Another important matter to be considered in connection with the action of light on the

silver haloids, and other compounds susceptible to its influence, is the function of sensitisers. It is found that the light's effect is greatly accelerated by the presence of another body capable of absorbing the halogens. Any substance which behaves in this way, so as to increase sensitiveness, is termed a "sensitiser." In the wet collodion process it is the silver nitrate which acts in this manner, and in the gelatine emulsion it is the gelatine.

THEORY OF SENSITISERS.

According to the sub-salt and oxy-haloid theories, accounting for the production of the latent image, it is supposed that an infinitesimal amount of halogen is liberated from the silver haloid. Now, on this theory the sensitiser present absorbs this halogen, and

removes it from the sphere of action as fast as it is formed. There is a good deal of evidence for this, from purely chemical reactions, because it is found that the velocity of a reaction is increased, by removing the products of the decomposition. But of course this will not account for the behaviour of sensitisers if the light does not decompose the silver haloid. As already mentioned, on the molecular strain line of reasoning, the supposition is put forward that the action of the sensitiser is to render the molecular strain set up in the silver haloid permanent. In other words, the molecular strain, or stress, produced in the sensitiser, may retard the self-recovery of the haloid, or may actually produce, or excite, a greater strain in the molecule of the haloid, than that obtained in the absence of the sensitiser.

DETERMINATION OF PLATE SPEEDS.

WARNERKE'S SYSTEM AND APPARATUS.

THE method of determining the sensitiveness of a photographic plate is to expose it to a light for a given period of time behind a sensitometer screen, and then to develop the plate and read off the highest number which is imprinted upon it. Leon Warnerke's sensitometer screen consists of a plate of glass divided into squares which are coated with coloured gelatine; each square has printed upon it a number which indicates its position in the series, and it is proportionately more highly coloured than its predecessor, so that the light passing through any square is one third less intense than that of the one before. The sensitometer screen is fitted into a special dark slide, and the plate, the speed of which is to be measured, is placed behind it, being held in position by a wooden back and metal springs. In the front of the dark slide a phosphorescent tablet is placed, and between it and the sensitometer is a shutter which can be withdrawn in the same way as that of an ordinary dark slide. The phosphorescent tablet is first exposed to the light of a magnesium ribbon, about 1 in. being burnt; it is then placed in the slide, and after one minute the shutter is withdrawn, and an exposure of half a minute given; the shutter is then closed, the plate taken out and developed. Instead of the phosphorescent tablet, a standard sperm candle placed at a fixed distance may be employed; but in order to ensure that the light is always of the same intensity, it should be allowed to burn at least five minutes before making the exposure. It is necessary that the

source of light, distance of light from the plate, time of exposure, and the developer should be the same in all cases, in order that the results may be comparable. The sensitiveness of the plate is then indicated by the highest number which can be read after development.

CADETT'S TABLE.

Mr. James Cadett has compiled the following table, which shows the relative sensitiveness of plates; the last number capable of being read is to the left of the table, the numbers ranging from 25 to 15 being a sufficient range for most plates:—

	NUMBER OF TIMES MORE SENSITIVE THAN:—										
	25	24	23	22	21	20	19	18	17	16	15
25	1	$1\frac{1}{3}$	$1\frac{1}{4}$	$2\frac{1}{4}$	3	4	5	7	9	12	16
24		1	$1\frac{1}{4}$	$1\frac{1}{2}$	$2\frac{1}{2}$	3	4	5	7	9	12
23			1	$1\frac{1}{3}$	$1\frac{2}{3}$	$2\frac{1}{3}$	3	4	5	7	9
22				1	$1\frac{1}{2}$	$1\frac{2}{3}$	$2\frac{1}{3}$	3	4	5	7
21					1	$1\frac{1}{3}$	$1\frac{2}{3}$	3	4	5	7
20						1	$1\frac{1}{4}$	$1\frac{3}{4}$	$2\frac{1}{4}$	3	4
19							1	$1\frac{1}{2}$	$1\frac{3}{2}$	$2\frac{1}{2}$	3
18								1	$1\frac{1}{3}$	$1\frac{2}{3}$	$2\frac{2}{3}$
17									1	$1\frac{1}{4}$	$1\frac{3}{4}$
16										1	$1\frac{1}{5}$
15											1

SPURGE'S SENSITOMETER.

Spurge's sensitometer is constructed upon a different principle to that of Warnerke. It consists of a box of quarter-plate size with a back which opens to allow the plate to be inserted, a front perforated with a series of thirty circular apertures of different sizes, and partitions which divide the box into a

number of compartments corresponding to the holes. This is to ensure that the light which passes through each hole only affects the portion of the plate directly behind it. The apertures are graduated in size, each aperture admitting one third more light than the preceding one, so that every third hole doubles the amount of

speed of plates was introduced by the late Dr. Ferdinand Hurter and Mr. Driffield, and now known as the H. and D. system, the result of their researches being embodied in a paper read before the Society of Chemical Industry in Liverpool, and published in the Journal of that Society, 1890, p. 155.

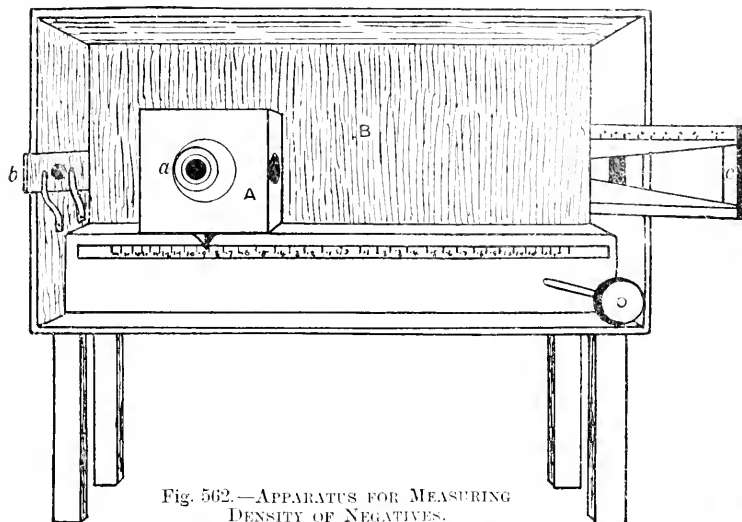

Fig. 562.—APPARATUS FOR MEASURING DENSITY OF NEGATIVES.

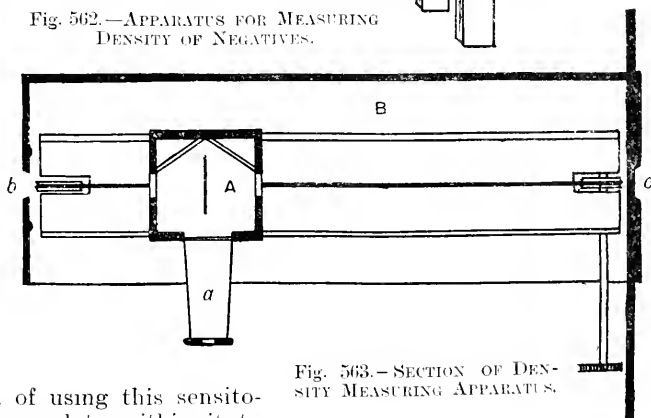

Fig. 563.—SECTION OF DENSITY MEASURING APPARATUS.

light. The method of using this sensitometer is to expose a plate within it to a fixed light for a given time, and, after development, to note the square upon which the faintest deposit is shown; the number corresponding with this is the sensitometer number of the plate.

HURTER AND DRIFFIELD SYSTEM.

The method now almost universally employed for measuring the densities and the

INSTRUMENT FOR MEASURING THE DENSITIES OF PLATES.

The instrument devised for measuring the densities of plates is a modification of the Bunsen photometer used for measuring the illuminating power of coal gas (Fig. 562). It consists of a cubical box, A, containing the paper disc with its

grease spot; through the eyepiece, *a*, both sides of the disc may be viewed at the same time in two mirrors. This chamber can be drawn along a fixed scale by means of an endless cord passing over two pulleys, that on the right side being moved with a key (Fig. 563). The disc chamber is enclosed in a larger box *B*, which contains apertures at both sides for admitting the light from two powerful petroleum lamps. Corresponding holes are bored in the disc chamber for admitting the light to the Bunsen disc. The larger box is 12 in. long, 6 in. wide, and 4 in. deep; the whole of the interior is blackened, and it is covered with a screen to exclude all extraneous light. The

the two images of the disc will be alike. If a plate be now inserted, which reduces the intensity I_1 to the intensity *i*, the disc chamber will have to be moved nearer to the plate in order to restore equilibrium in the two luminosities. If the distance of the disc from the centre of the instrument be now represented by *y*, then—

$$(2) \frac{i}{(1-y)^2} = \frac{I_2}{(1+y)^2} \text{ or } \frac{I_2}{i} = \frac{(1+y)^2}{(1-y)^2}$$

If the two equations be multiplied, a fraction is obtained which measures the opacity:—

$$\frac{I_1}{i} = \left(\frac{1-x}{1+x}\right)^2 \left(\frac{1+y}{1-y}\right)^2$$

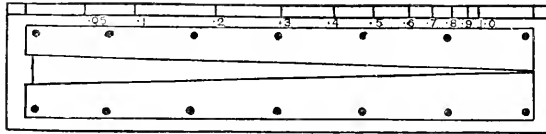

Fig. 564.—MOVABLE SCALE.

opening on the left hand side is covered with a diaphragm which reduces it to about $\frac{1}{4}$ in. diameter, and the plate to be examined is held against this opening by a couple of clips, *b*. On the right hand side the hole is covered with a rectangular diaphragm having an opening $\frac{1}{2}$ in. long and $\frac{1}{4}$ in. wide, the length being vertical. The length of this opening can be reduced by a movable tapered diaphragm sliding in front of it, *c*. The apparatus is provided with two scales, a fixed one on the front of the instrument and a movable one on the taper diaphragm at the side. An enlarged view of this is seen in Fig. 561. The method of using the apparatus and the principle on which it is graduated may be briefly described as follows: In the first place it is assumed that the two lamps are equidistant from the centre of the instrument, and this distance may be represented by *l*, the intensity of the light on the left is I_1 , and that on the right I_2 if the disc is moved to a distance *x* from the centre of the instrument, so that

$$(1) \frac{I_1}{(l-x)^2} = \frac{I_2}{(l+x)^2} \text{ or } \frac{I_1}{I_2} = \left(\frac{l-x}{l+x}\right)^2$$

As the logarithm of the opacity is the density of the plate, $\log. \frac{I_1}{I_2}$ is the density.

$$D = \log. \left(\frac{l+y}{l-x}\right)^2 - \log. \left(\frac{l+x}{l-y}\right)^2$$

At the distances *x* and *y* on the scale the values of $\log. \left(\frac{l+x}{l-x}\right)^2$ and $\log. \left(\frac{l+y}{l-y}\right)^2$ may be marked, and by reading off these logarithms, subtracting one from the other, the density is at once obtained. For general convenience vulgar and not hyperbolic logarithms are used. By using small diaphragms any error due to the position of the lamps is corrected, and the distance *l* can be measured between the centre of the instrument and the diaphragm. It is hardly necessary to insist that great care is requisite to secure perfect uniformity of the light. With a box 12 in. long between the diaphragms, the zero point or *l* is at 6 in., and the other points in the scale are found in the following table, the graduations on both sides of zero being symmetrical, and for convenience the points thus formed are again subdivided.

TABLE I.—FIXED SCALE OF INSTRUMENT.

$\text{Log.} \left(\frac{+x}{-x} \right)^2$	DISTANCE FROM CENTRE OF INSTRUMENT.	$\text{Log.} \left(\frac{+x}{-x} \right)^2$	DISTANCE FROM CENTRE OF INSTRUMENT.
0.0	7 × 0.000	0.9	7 × 0.476
0.1	7 × 0.057	1.0	7 × 0.519
0.2	7 × 0.114	1.1	7 × 0.560
0.3	7 × 0.171	1.2	7 × 0.599
0.4	7 × 0.226	1.3	7 × 0.634
0.5	7 × 0.280	1.4	7 × 0.667
0.6	7 × 0.332	1.5	7 × 0.698
0.7	7 × 0.382	1.6	7 × 0.726
0.8	7 × 0.430	1.7	7 × 0.752

The movable scale is attached to the upper edge of the taper diaphragm; this is made of sheet metal, and is about 12 in. long and 2 in. wide. In the diaphragm is cut a triangular opening 10½ in. long and ½ in. wide at the base. The sides of this triangle must be absolutely straight lines. This diaphragm is used for reducing the amount of light passing through the fixed diaphragm on the right side. The zero point of the scale is marked at 10 in. distance from the apex, and the other points of the scale are marked to show directly the densities. For, at any distance x from the apex, the area of the opening and consequently the intensity of the light is reduced as 10 :: x, and the vulgar logarithm of the fraction $\frac{10}{x}$ is the corresponding density which is marked on the scale. The following table shows the distances from the apex at which the numbers are placed:—

TABLE II.—MOVABLE SCALE.

Value of $\text{Log.} \frac{10}{x}$	Distance from Apex.	Value of $\text{Log.} \frac{10}{x}$	Distance from Apex.
.00	10 inches	0.50	3.16 inches
.05	8.91 "	0.60	2.51 "
.10	7.94 "	0.70	2.00 "
.20	6.31 "	0.80	1.58 "
.30	5.01 "	0.90	1.28 "
.40	4.00 "	1.00	1.00 "

One or two examples may now be given of the method of measuring densities with this instrument. For measuring a small density the disc chamber is first moved to

such a position that the images of both sides of the disc are alike; the plate is then fixed in the opening to the left, and the sliding scale on the right is moved until the light is sufficiently reduced and the images are again equally illuminated; the index on the diaphragm scale may then be read, and gives the density of the plate. In measuring a high density, the sliding scale is placed at zero and a piece of opal glass is fixed behind the diaphragm on the right to reduce the intensity of the light; the disc chamber is then moved to the right until both sides of the disc are equally illuminated. The plate is then inserted on the left, and the disc chamber moved in that direction till equality is restored; if this cannot be done with the disc chamber alone, the diaphragm on the left may also be used. Supposing the index to stand at 1.1 on the right, and afterwards at 1.5 to the left of the zero, then the density would be 1.1 + 1.55 = 2.65. If the index stood at 1.1 on the right, and on moving the disc chamber to 1.7 equilibrium was not restored, and the movable scale had to be placed at .75, then the density would be 1.1 + 1.75 + .75 = 3.55. This is a very high density, and does not occur in ordinary negatives; a density of 3.55 will only allow about $\frac{1}{35.16}$ th of the light falling upon it to pass. A plate of density 1 allows $\frac{1}{10}$ th of the light to pass, and a density of 2 allows $\frac{1}{100}$ th of the light to pass, as the logarithm of 10 is 1, and that of 100 is 2.

UNITY OF LIGHT AND TIME.

In determining the densities obtained on exposing different plates a unit of light and a unit of time were required. The unit of light fixed upon is that of a standard sperm candle at one metre distance, and the unit of time, the second. The product of the unit of light and the unit of time is called 1 "candle-meter second," and is the unit of exposure. Before making an exposure the candle is allowed to burn until the flame has settled to a height of 45 mm. from the top of the spermaceti to the tip of the flame, otherwise the light is not to be

depended upon; to ensure protection from draughts the candle is enclosed in a blackened box, which also prevents any light being reflected from bright objects in the room. The unit of exposure has been found a very convenient one in practice, and it is one that can be readily obtained: it has been found immaterial whether an exposure be made for 40 seconds to a light of $\frac{1}{4}$ candlemeter, or for 10 seconds to a light of 1 candlemeter; the ratios of the densities are also the same whether a candle, an oil lamp, or daylight be used, provided the product of intensity of light and time of exposure

are exactly equivalent to the ratios of the two exposures, or, in other words, the amount of silver reduced by the developer is directly proportional to the exposure. In the period of correct exposure, the densities are proportional to the logarithms of the exposures. This is shown on the diagram, Fig. 365, in which the densities are the ordinates and the logarithms of the exposures are the abscissa, while the period of correct representation is shown by a straight line. The densities of dozens of plates falling within this period have been measured, and they all conformed to the simple equation—

$$D = \gamma \left[\log. It + C \right]$$

D being the density, γ a constant depending on time of development, It the product of intensity of light and time, and C a constant depending upon the speed of the plate. The periods of over-exposure and of reversal follow, but need no comment, as they do not come within the scope of the present subject.

ABSORPTION OF LIGHT.

It is of importance to understand that of the light which reaches a photographic plate only a portion of it is absorbed, and only a fraction of the latter is concerned in the chemical change. A portion of the light is reflected from the plate, and another portion passes through unchanged. Of that portion which is absorbed, only a part is used in changing silver bromide into the condition in which it can be reduced. If silver bromide is exposed to light it is altered in such a way as to produce the "latent image," and when it is so far altered as to produce the maximum density upon development, any light which subsequently falls upon it is absorbed without in any way adding to that density. Hence the light absorbed by a particle of silver bromide, which has already received sufficient to bring it into this condition of instability, is useless. The law which connects the densities with exposures may be calculated, and the formula given is—

$$D = \gamma \log. \left[\frac{1}{\epsilon} \left(1 - (1 - \beta) \frac{It}{i} \right) \right]$$

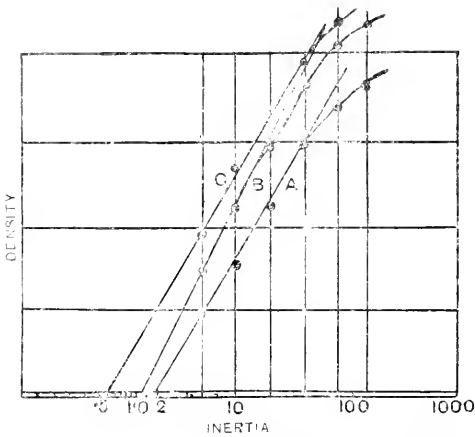

Fig. 365.—DIAGRAM SHOWING SPEED READINGS.

be the same. For instance, on three separate days, and on three separate plates of the same make, by carefully measuring the time of exposure and of development, three densities of 0.75, 0.73, and 0.72 were obtained; and in another experiment in which four different candles were used, and exposures of 10 seconds given upon the same plate, densities of 0.49, 0.49, 0.5, and 0.45 were obtained.

PERIODS OF EXPOSURE.

By numerous experiments it was found that the times of exposure could be divided into four periods: the period of under-exposure, the period of correct exposure, the period of over-exposure, and the period of reversal. In the period of under-exposure, the ratios of two densities



PICTURE PRINTED BY COMBINATION OF YELLOW, RED, AND BLUE INKS ONLY.

σ being the opacity of the plate to the chemically active rays, B a fraction, the hyperbolic logarithm of which is $-\frac{1}{i}$; t is the exposure, and i a symbol to denote what is known as the inertia or slowness of the silver bromide. The densities calculated by this formula approximate fairly closely to those obtained by experiment, as will be seen in the following table:—

but it is too complicated to be regularly used except as a check upon the simpler one. In the formula—

$$D = \gamma \log \left(O - (O - 1) \beta \frac{It}{i} \right)$$

$(O-1)$ may be replaced by the symbol O when that represents a large number (*i.e.* when the plate is thickly coated), and as

TABLE OF DENSITY CALCULATIONS.

EXPOSURE. C.M.S.	DENSITY FOUND.	DENSITY CALCULATED.	EXPOSURE. C.M.S.	DENSITY FOUND.	DENSITY CALCULATED.
1	.060	.092	128	1.875	1.800
2	.160	.172	256	2.290	2.165
4	.340	.302	512	2.535	2.518
8	.500	.482	1024	2.985	2.860
16	.715	.735	2048	3.415	3.138
32	.940	1.050	4096	3.280	3.328
64	1.345	1.405	8192	3.405	3.465

The short exposures show that the densities are proportioned to the exposure, while the exposures from 16 up to 1,000 C.M.S. (candlemeter seconds) give very nearly equal increments of density for every successive double exposure; while above 1,000 there is a rapid decline in the production of density. The figures from 16 to 1,000 C.M.S. therefore belong to the period of correct representation, and are very similar to those obtained by the simple linear equation—

$$D = \gamma \left[\log It - C \right].$$

SPEED OF SENSITIVE PLATES.

The approximate formula first given may be employed for measuring the speed of a sensitive plate, though it must be understood that it is never strictly true, and can only be used for exposures which fall within the period of correct representation; it is sufficiently correct for ordinary work, and it is easily applied. The more correct formula is the mathematical expression of the idea that a certain amount of energy is needed to bring a particle of silver bromide into the condition in which it can be developed,

$\log \epsilon \beta$ is $-\frac{1}{i}$ the equation may be written—

$$D = \gamma \log \left(\frac{It}{i} \right)$$

This equation holds good only when the numerical value of $\frac{It}{i}$ is greater than 1 and less than the opacity σ . It is between these limits that the equation only holds good. The constant c in the approximate formula is the logarithm of i , which represents those properties of the silver bromide which constitute its sensitiveness, and which govern the inertia of the plate.

RELATION BETWEEN INERTIA AND DENSITY.

To produce upon the same densities two richly-coated plates of different inertias i and i_1 , with a light of the intensity I , the exposures would have to be so arranged that—

$$\frac{It}{i} = \frac{It_1}{i_1}$$

or the times would have to be such that—

$$\frac{t_1}{i_1} = \frac{t}{i_0}$$

The determination of the numerical value of i is therefore of importance, for it not only measures the inertia of a plate, but

it may also be used for determining the speed of different plates; the values of i being known for several plates, the exposures required for these plates can easily be obtained if the exposure is known for one of them. The density of the image being an abstract number, the ratio $\frac{It}{i}$ is also an abstract number, and i is therefore an exposure. Though i represents the inertia of the plate, it may be used to measure the least exposure which is necessary to mark the period of correct representation. The speed of the plate is the inverse value of this; *i.e.* the longer the exposure required to reach the period of correct representation, the slower the plate; the speed of the plate is therefore represented by $\frac{1}{i}$.

MAKING EXPERIMENTAL EXPOSURES.

For measuring the value of i , at least two exposures falling within the period of correct representation must be obtained, developed, and the densities (exclusive of fog) determined; two equations are thus obtained connecting the two densities D_1 and D_2 with the two exposures E_1 and E_2 . Thus—

$$D_1 = \gamma \log \frac{E_1}{i} \quad \text{and} \quad D_2 = \gamma \log \frac{E_2}{i}$$

from which is obtained by elimination—

$$\log i = \frac{D_2 \log E_1 - D_1 \log E_2}{D_2 - D_1}$$

and

$$\gamma = \frac{\log E_2 - \log E_1}{D_2 - D_1}$$

In order to obtain the two proper exposures, eight exposures are made on the one plate, only the centre of which is used owing to the edges usually being thinner; these exposures comprise 2.5, 5, 10, 20, 40, 80, 160, and 320, C.M.S., while a portion of the plate is left unexposed. The plate is developed in ferrous oxalate, is properly washed, and then fixed in a clean bath of thiosulphate, after which it is washed and allowed to dry spontaneously. The time of development is judged by the density, allowing a measurable deposit to form on the lower exposures.

The densities are measured, and also any density on the unexposed strip, which is subsequently corrected for, when the densities "exclusive of fog" are obtained.

TYPICAL DENSITY MEASUREMENTS.

The following results obtained with a Manchester slow plate will illustrate the foregoing procedure:—

Exposures..	2.5"	5"	10"	20"	40"	80"	160"
Densities ..	.085	.175	.250	.460	.755	1.010	1.270
Differences..		.090	.075	.210	.295	.255	.260

The exposures from 20 to 160 C.M.S. may therefore be said to fall within the period of correct exposure, and if we take 20 and 160 for the calculation we obtain:—

$$\log i = \frac{1.270 \times \log 20 - .460 \times \log 160}{1.270 - .460}$$

or $\log i = 0.787$, and from a logarithm table the figure for i is 6.12 candlemeter seconds. Another plate of the same make gave the following figures:—

Exposures	10"	20"	40"	80"
Densities340	.590	.910	1.260
Differences290	.320	.350

Choosing the differences at 20 and 80 minutes we obtain—

$$\log i = \frac{1.260 \times \log 20 - 0.590 \times 80}{1.260 - 0.590}$$

or $\log i = 0.771$, and $i = 5.90$ candlemeter seconds. These results are sufficiently close for all ordinary purposes. Similar experiments with Ilford plates gave the value i or the inertias as follows:—Ilford ordinary, 2.0; Ilford rapid, 1.4; and Ilford special rapid, 0.56; their relative speeds are therefore as 1 :: 1.41 : 3.4

THE CHAPMAN JONES OPACITY METER.

A useful instrument for measuring the density of plates, designed by Mr. Chapman Jones, is shown by Fig. 586. An incandescent gas light is arranged to shine directly upon one side of an Abney screen, while, by means of three mirrors and a velvet-lined tube with diaphragms to regulate the intensity of the light, a beam is

carried round to illuminate the translucent half of the screen. The latter is attached to a sliding carrier provided with clips to hold the plate. The graduated scale along which the carrier moves is marked to give the required density in opacity logarithms. This arrangement is obviously available for a number of different purposes besides that for which it is primarily intended; for example, the estimation of exposures in bromide printing, etc.

FINDING "ACTINOGRAPH SPEED" OF PLATE.

The exposure to be given in the camera can easily be found by means of the

going paragraphs, filled a long-felt want, and it has been of great use both to the makers and the users of plates. It is at once both scientific and practical, the unit or candlemeter second being the best hitherto proposed, and one which can at any time be produced. The inertia of a plate having been measured as described, it is possible to so time the exposures in the camera as to get densities which are directly proportional to the logarithms of the intensities of the light which produces them, and thus to produce negatives which are as nearly as possible perfect. The density obtained in any particular experiment is dependent upon the time of

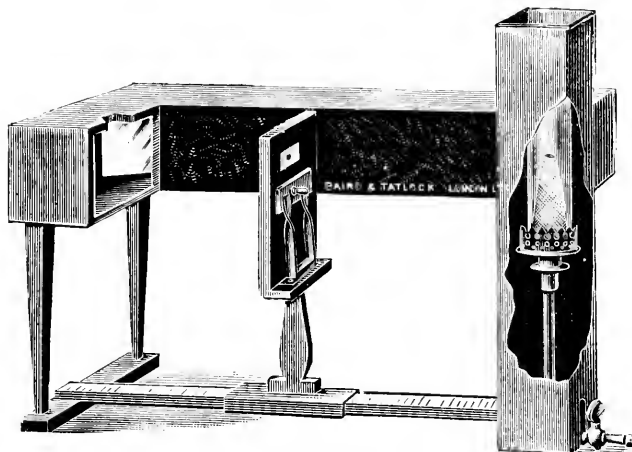

Fig. 566.—THE CHAPMAN JONES OPACITY METER.

Hurter and Driffield Actinograph when the inertia of the plate is known. The "actinograph speed" of the plate is obtained by means of the formula $s = 34 i$, when s is the speed of the plate and i the inertia. For instance, the speed of the Ilford plates is as follows:—

	<i>Speed.</i>
Ilford ordinary	$= \frac{34}{2} = 17$
Ilford rapid	$= \frac{34}{1.4} = 24$
Ilford special rapid	$= \frac{34}{0.56} = 60$

CONCLUDING REMARKS.

The method of measuring the speed of a photographic plate, described in the fore-

going paragraphs, filled a long-felt want, and it has been of great use both to the makers and the users of plates. It is at once both scientific and practical, the unit or candlemeter second being the best hitherto proposed, and one which can at any time be produced. The inertia of a plate having been measured as described, it is possible to so time the exposures in the camera as to get densities which are directly proportional to the logarithms of the intensities of the light which produces them, and thus to produce negatives which are as nearly as possible perfect. The density obtained in any particular experiment is dependent upon the time of exposure as well as upon the action of light. During development the growth of density is rapid at first, but it gradually slows down, and finally comes to a standstill; the subsequent reduction being due to the chemical action of the developer upon the unaltered silver bromide, and being really fog, in no way alters the ratios of the densities, though it may lead to a certain amount of exaggeration in the appearance of a negative. Ferrrous oxalate was found to have so little effect upon silver bromide which had not been exposed to light, that no appreciable density or fog could be produced by its means upon a good plate, hence it is especially useful for development in determining plate speeds.

PHOTOGRAPHY IN COLOURS.

INTRODUCTION.

FROM the first discovery of photography to the present time the search for a simple and practical method of obtaining pictures in the colours of Nature has exercised a powerful fascination over many able investigators. Although the goal has often been nearly reached, absolute success has not yet been attained. The ideal process by which a photograph in natural colours can be secured by one short exposure, and developed in the ordinary manner, remains still as far off as ever. The various processes, however, which approximate more or less closely to the desired object, are full of ingenuity and interest, and one or other of them may well serve as a foundation for the perfect method of the future.

EARLY ATTEMPTS WITH SILVER CHLORIDE.

In 1810 T. J. Seebeck is mentioned in Goethe's "*Farbenlehre*" as having noticed the various colours produced on chloride of silver by the rays of the spectrum: brown, violet, and blue in the violet rays, blue in the blue rays, and red in the red rays. In 1839, Sir John Herschel, in a paper read before the Royal Society, described the beautifully tinted spectrum which he had been able to obtain on paper spread with silver chloride, by means of sunshine thrown through a glass prism. In 1844, Robert Hunt made known to the world the result of many interesting experiments in the same direction, which, however, led to no definite result. In 1848, Edmund Becquerel, a French savant, succeeded in obtaining coloured images of the spectrum and other simple subjects on chlorinised silver plates; in this he was

followed by Niépce St. Victor, but neither of them, unfortunately, were able to fix the pictures so obtained, which faded on a brief exposure to light. Testud de Beauregard, Alphonse Louis Poitevin, Sir W. (then Captain) Abney, E. de St. Florent and others, experimented further with silver chloride and allied salts, but without attaining the desired goal; although Poitevin succeeded in partially fixing coloured pictures on paper sensitised with silver chloride by means of sulphuric acid.

CAREY LEA AND THE PHOTO SALTS.

In 1857, Mr. W. Carey Lea caused much sensation by a series of remarkable investigations into the nature of the haloid salts of silver, which, he showed, were capable of assuming many different colours under the action of light, and even by chemical agency alone. Although the bromide and iodide of silver appeared to produce very beautiful tints, the chloride was found to give the greatest variety, particularly the red chloride. The latter is obtainable in an almost endless number of ways; most conveniently, perhaps, by acting on normal chloride with reducing agents. To the red silver chloride, and the corresponding bromide and iodide, Carey Lea gave the name of "photo salts," calling them respectively silver photochloride, photobromide, and photoiodide.

EXPERIMENTS WITH RED SILVER CHLORIDE.

Some highly interesting results were obtained by Carey Lea with silver photochloride. The spectrum was fairly repro-

duced, excepting the yellow and green, and beneath glasses of different colours the salt tended to assume a similar tint. Under the action of white light the chloride darkened, but by the addition of certain other chlorides, particularly those of lead and zinc, the property of bleaching under the influence of white light was conferred. The sensitiveness of the salt, also, was found to be greatly increased by the presence of sodium salicylate. It is not at all improbable that, as Carey Lea himself maintained, the future attainment of photography in colours will be found to depend on a wise application of the extraordinary properties of silver photochloride, and it is much to be regretted that ill-health and advancing years precluded this brilliant theorist and investigator from laying the coping stone to his invaluable researches.

THE LIPPMANN PROCESS.

The Lippmann process, which depends on the effects of the phenomenon known as "interference," was announced by Professor Gabriel Lippmann to the French Academy of Sciences in 1891. A perfectly transparent and very finely grained plate is placed with its film side in contact with a reflecting surface consisting of a trough of mercury, in such a manner that the plate forms one of the sides of the trough. During exposure, the light waves instead of rushing through the sensitive film with inconceivable velocity, and so obliterating all record of their form and structure, are reflected and thrown back upon themselves by the surface of the mercury. The result is that stationary waves of light are formed in the film itself, which are capable on development of yielding microscopically fine laminae or divisions of metallic silver, each colour of the original having its own particular wave length remodelled with exactness in the structure of the developed image. The consequence is that, although, if looked through in the usual way, the negative seems to present no special features of interest, if viewed by reflected light at a certain angle the colours of the original are at once apparent. The light has been decomposed

by the metallic laminae of the film, and as these exactly reproduce the wave structure of the original colours of the image, the latter is necessarily viewed in its own correct tints. Although the honour of the actual achievement belongs to Professor Lippmann, he was not the first who had suggested the possibility of producing stationary light waves in a photographic film. Dr. Wilhelm Zenker, Otto Wiener, and Lord Rayleigh had previously made valuable contributions to the theory of the process.

MAKING EMULSION FOR LIPPMANN PROCESS.

The fine-grained plates for this process cannot be obtained commercially, but must be made by the worker himself. There are various formulæ recommended for the purpose, but the following, due to Mr. Edgar Senior, of the Battersea Polytchnic, who is admittedly the most able British exponent of the process, can scarcely be improved upon :—

No. 1.				
Gelatine	75 grs.
Potassium bromide	32 grs.
Water (distilled)	8 oz.
No. 2.				
Gelatine	75 grs.
Water (distilled)	8 oz.
Silver nitrate	45 grs.

Both solutions are heated to 95° Fahr., and the silver solution (No. 2) is then added to No. 1.

COATING THE PLATE.

Before the emulsion is applied to the plate, it must be rendered colour sensitive, or, as it is sometimes called, panchromatic; this is done by the addition of certain dyes. The following formula, recommended by Dr. R. Neuhauss, of Berlin, is very suitable:—

Alcoholic solution of cyanine,	1 in 500	50 minims.
Alcoholic solution of erythrosine,	1 in 500	33 minims.
Alcoholic solution of glycin rel,	saturated	170 minims.

These quantities are to be added to every $3\frac{1}{2}$ oz. of emulsion. The latter is then filtered through fine flannel or silk, and, the plates being first thoroughly cleaned, the coating is immediately proceeded with. The plates are now allowed to set on a levelling slab, at as low a temperature as possible, ice being used for the purpose if necessary. When perfectly set, they are washed for half-an-hour, drained, and allowed to dry. Plate glass is best for coating, and the gelatine may be either Nelson's No. 1, Drescher's, or Lautenschlager's. The latter, obtainable

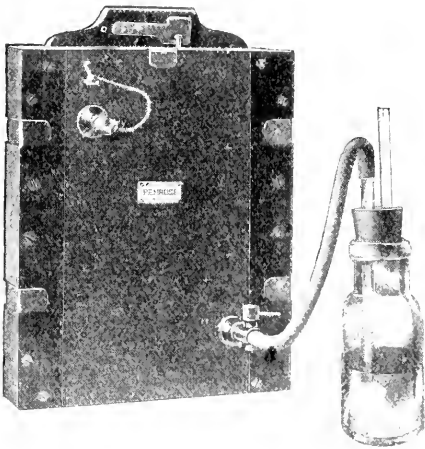

Fig. 567.—SPECIAL DARK-SLIDE FOR LIPPMANN PROCESS. (PENROSE.)

from the maker at Berlin, is preferred by Dr. Neuhauss, and is said by many to give the best results. The coating must be done as quickly as possible, and too large a number should not be done at a time, or the emulsion will ripen during the process, and the grain of the plates will be coarse and unsuitable.

INCREASING THE RAPIDITY OF EMULSION.

As a necessary consequence of their fine grain, the plates are extremely slow, which has led various experimenters to seek for an increase of rapidity by other means than that used in making ordinary plates. Professor Lippmann pours an

alcoholic solution of aceto-nitrate of silver over the plate, immediately before exposure. Lumière employs the same agent, but with water instead of alcohol as the solvent. Mr. Edgar Senior has obtained good results by adding 3 grs. of silver eoside (a chemical compound of silver and eosine) to each $3\frac{1}{2}$ oz. of emulsion. Edward Valenta prefers, however, to add sodium sulphite to the emulsion, which it is claimed enables the latter to be heated to a higher temperature subsequently, without affecting the fineness of the grain. The temperature in this case may be raised to 102° Fahr. As may be readily imagined, except in the hands of an expert, it is far easier to secure good results with the original emulsion, for any attempts at increase of speed simply add to the likelihood of failure, by introducing many possibilities of complication.

EXPOSURE.

Before placing the plate in the slide, it should be seen that the glass side, which faces the lens, is perfectly clean; any particles of dust should be dislodged by tapping gently on the bench. A special slide is used, as shown by Fig. 567. The plate is placed in this, and the mercury is then poured quickly and evenly in, flowing it over the plate without pause or stoppage. It is essential that the mercury should be chemically pure, and it may be obtained specially prepared for use with this process. The plate is then ready for exposure, for which it is impossible to lay down any definite rules; for this purpose exposure meters are of little use. A typical exposure on a brilliantly lit scene in full sunlight, with a lens working at $f/8$, would be about four minutes. Of course, it is possible by using a lens of larger aperture to greatly diminish the exposure, and this is generally done by those who work the Lippmann process to any extent.

DEVELOPMENT.

After exposure, the plate is withdrawn from the slide, and lightly dusted with a

flat camel-hair brush moistened in alcohol. This is to remove any particles of mercury which may happen to be clinging to it. It can then be developed, for which purpose almost any slightly diluted normal developer may be used. Care should be taken not to over develop; a rather thin negative intensified afterwards gives the most satisfactory results. When development is completed, the plates are rinsed and fixed in a hypo. solution of half the usual strength. They must not remain in this long, since, unlike an ordinary negative, the silver deposit is so fine in character that it is easily fixed right out if suffered to remain. The plate is then well washed, and bleached in—

Mercuric chloride	6 grs.
Potassium bromide	6 grs.
Water (distilled)	3½ oz.

When sufficiently bleached, it is rinsed and either re-developed, preferably with amidol, or blackened with a 10 per cent. solution of sodium sulphite. After a final thorough and careful washing, the plate can be stood up to dry in a place perfectly free from dust. The colours become visible as soon as the drying is accomplished.

MOUNTING AND VIEWING THE PHOTOGRAPH.

Owing to its peculiar structure, the finished photograph not only requires to be looked at in a certain way, but must be specially mounted to avoid surface reflections, which would otherwise impair the brilliancy of the colours. The best result is found to be obtained by cementing the plate with Canada balsam to a prism of low angle, backing it with black varnish, and binding it round the edges. Suitable prisms and varnish may be purchased for the purpose. Lippmann photographs are seen to the greatest advantage when inclined at a slight angle from the eye of the observer, and lit by light reflected from a mirror placed in front and above, so that a satisfactory amount of light is thrown down on the picture. It is an improvement to enclose the plate in

a small box lined with black or non-reflecting material, and to view it through a lens or eyepiece; the mirror in this case being outside the box, and throwing its light through an aperture cut in the top. The angles of both the mirror and the plate should be adjustable by screws or swivels conveniently situated. Although not really necessary, such an arrangement certainly enables the pictures to be seen with far greater satisfaction. It is possible that this process will soon be greatly simplified, for M. Rothé, of Paris, announces that equally good results may be obtained without the mercury slide, by simply placing a Lippmann plate with its glass side to the lens; the reflection, in this case, being from the air surface in contact with the back of the plate.

'CROS AND DUCOS DU HAURON.

In 1867, Charles Cros patented a method of three-colour heliochromy, in which three negatives were to be taken by red, yellow, and blue light respectively. The positives obtained from the negatives, suitably stained, were to be thrown into one picture by means of a kind of zoetrope. In 1868, Louis Ducos du Hauron introduced a somewhat similar method, and also another in which a single plate was exposed behind a screen ruled in three colours, after the fashion of that now known as the Joly process. In 1869, Ducos du Hauron, in a work published by Marion of Paris, gives an account of his three-colour process, as still further improved; the negatives were to be taken with the aid of screens corresponding to the three primary colour sensations, and a triple print made with transparent colours of complementary tints. In 1881, Cros, in "*Le Moniteur de la Photographie*," describes an ingenious method of polychromy in which a sensitive surface composed of various colours was used, the tints being so chosen that each was bleached by its complementary colour; this being, in fact, an anticipation of the later processes of Szczepanik and Lumière. It is, indeed, curious to see how far these early investigators succeeded in forestalling, so

far as regards theory, at any rate, the laboured advances of the following generation. The theoretic aspect of this subject, indeed, is singularly complete.

THE THEORY OF COLOUR VISION.

Thomas Young, in 1810, and Hermann von Helmholtz, many years later, have between them given us the present generally accepted theory of colour sensation, which, in consequence, is known as the Young-Helmholtz theory. This lays

down the principle that our eyes are capable of receiving three distinct forms of stimulus, or primary colour sensations—the red, the green, and the blue-violet. Whether the retina possesses three different groups of nerves, or whether one set of nerves can receive three distinct impressions, is a matter of uncertainty. It has, however, been proved that by mixtures of two or all of the three colours corresponding to the three primary sensations, in correct proportions, the impression of any other required tint or colour may be successfully made. As a matter of fact, colour in itself has no real existence. It is simply because different objects absorb certain rays of light, and reflect others to our eyes, which are capable of exciting the nerves of colour sensation in a particular manner, that the objects give the impression of possessing colour. It is quite possible for an individual to be deficient or lacking in the nerves of a certain colour sensation, in

THE WORK OF CLERK-MAXWELL.

Professor Clerk-Maxwell, in 1861, in a lecture delivered at the Royal Institution, practically demonstrated the truth of the Young-Helmholtz theory by means of three optical lanterns throwing light of the three primary colours. It was shown to be possible to combine the three coloured lights, so as to produce white, or by mix-

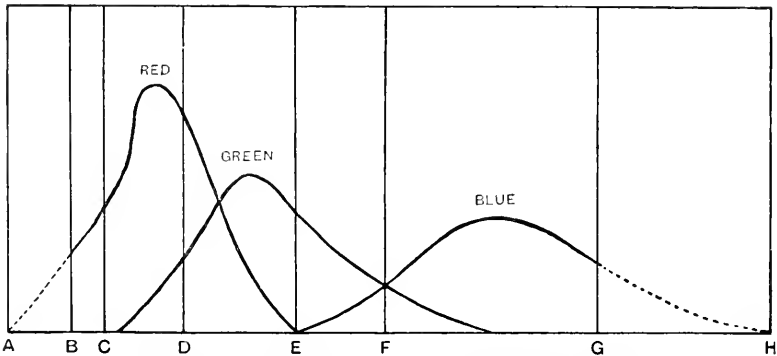

Fig. 568.—CLERK-MAXWELL COLOUR SENSATION CURVES.

ing them in suitable proportions to obtain any required tint. Clerk-Maxwell also succeeded in obtaining three different photographs of a coloured object, taken through the three colour screens, thus representing the red, the green, and the blue parts respectively of the image. These three photographs, when shown in the lantern and superposed on each other, gave an image reproducing as far as possible the tints of the original. The most valuable feature of the work of Clerk-Maxwell, however, is his proof that the primary colour sensations are excited by mixtures of colours, and not simply by pure red, green, and blue. By means of curves, he was able to show exactly those parts of the spectrum which took part in exciting the three fundamental sensations (see Fig. 568). In the diagram it will be noticed that the red sensation curve includes not only red, but orange, yellow, and yellow-green; the green curve proceeds from the orange through the

ing them in suitable proportions to obtain any required tint. Clerk-Maxwell also succeeded in obtaining three different photographs of a coloured object, taken through the three colour screens, thus representing the red, the green, and the blue parts respectively of the image. These three photographs, when shown in the lantern and superposed on each other, gave an image reproducing as far as possible the tints of the original. The most valuable feature of the work of Clerk-Maxwell, however, is his proof that the primary colour sensations are excited by mixtures of colours, and not simply by pure red, green, and blue. By means of curves, he was able to show exactly those parts of the spectrum which took part in exciting the three fundamental sensations (see Fig. 568). In the diagram it will be noticed that the red sensation curve includes not only red, but orange, yellow, and yellow-green; the green curve proceeds from the orange through the

yellow, green, and green-blue; while the blue sensation is aroused by the blue-green, blue, and violet rays of the spectrum. In 1865, Henry Collen, in a contribution to "The British Journal of Photography," suggested that three negatives might be taken representing the three primary colour sensations, and from those three coloured positives, which superposed would truthfully reproduce the tints of the original. It was not, however, till much later that any actual work was done in this direction.

TRICHROMATIC AND DICHROMATIC PHOTOGRAPHY.

Based practically upon the colour sensation theory of Young-Helmholtz, with the additional light given by Clerk-Maxwell, a number of different methods of three-colour, or sometimes two-colour, photography have been from time to time devised. It must be admitted that although the Lippmann process is certainly the most simple and direct, its rendering of colour is not always as perfect as might be wished; in addition, it has the disadvantages that further impressions cannot be obtained from the negative, and that it is necessary to view the latter in a special manner. Under the circumstances, therefore, the attention of investigators has been largely directed to the perfection of a practical method of three-colour photography, as giving better results, although less satisfactorily meeting the theoretical requirements of the ideal process of photography in natural colours.

THE IVES PROCESS.

To Frederick Eugene Ives, of Philadelphia, is due what is probably the most beautiful and convincing process of three-colour photography. Three negatives are taken corresponding with the colour sensations as plotted out by the Clerk-Maxwell curves; suitable screens or colour filters being interposed, so that only the rays which go to excite each particular sensation are allowed to act on their respective negatives, which, for convenience,

may be taken on different parts of the same plate. Colour sensitive plates are, of course, employed, such as the Cadett Spectrum or the Lumière Panchromatic. A repeating back is commonly used, so that the three portions of the plate may be exposed in turn. Mr. Ives has designed a camera which enables all three exposures to be given at once, with the same lens; it requires, however, too much care and too fine an adjustment to render it suitable for everyday work. It is possible that a future simplification of this apparatus will render it more applicable to the purposes of the ordinary worker.

EXPOSURE, DEVELOPMENT, ETC.

Screens or colour filters of the three correct tints are obtainable, generally consisting of thin stained films of gelatine or collodion, enclosed between two glasses. The exposure has to be carefully proportioned, so that each colour receives a due amount of time. Mr. A. Watkins suggests that a useful aid to this is to include a small patch of white in the object, which should be developed to equal density in the three negatives. Softness and delicacy should be aimed at, or the colours will be too glaring and crude in the final result. The negatives are developed and finished in the ordinary way, except that, as they are abnormally sensitive to all colours, the operation must take place almost in the dark. Three positives are then made from the three negatives, in just the same way as commonly pursued in making lantern slides. Up till now, these positives appear to present nothing unusual; it is only on looking at them, as thrown together in a special manner by an ingenious instrument called a "Kromskop," or Photo-chromoscope, that the colours of the original are correctly interpreted.

HOW THE COLOURS ARE RECORDED.

It has been seen that there are three transparencies, answering respectively to the red, green, and blue-violet portions of the subject photographed. In the Kromskop these are viewed through red, green,

and violet glasses, the three images being thrown at the same time into one. This will be better understood by reference to Figs. 570 to 575, which show the three negatives and transparencies obtained from a simple object, selected for the purpose of illustration. Fig. 569 represents the original, consisting of a violet cross on a red shield, the surrounding ground being green. Figs. 570, 571, and

opaque patch. It is perfectly evident, therefore, that when the transparencies are all viewed at once through glasses of suitable colours, a correctly tinted reproduction of the original will be seen. Compound colours, of course, will be represented on two or even three of the transparencies, and will be truthfully

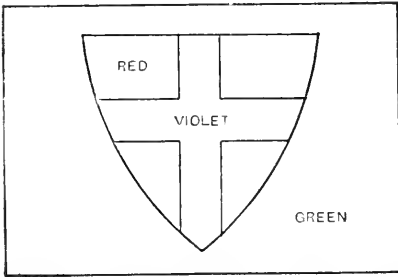

Fig. 569.—THE IVES PROCESS. ORIGINAL SUBJECT.

572 show the red, green, and blue-violet negatives obtained from such a subject: while Figs. 573, 574, and 575 show the

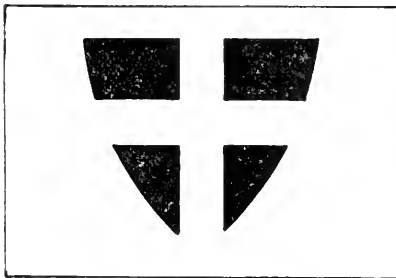

Fig. 570.—RED NEGATIVE.

corresponding transparencies. Comparison of these, one with another, will enable the principle to be readily grasped. For example, if a red glass were placed behind the red transparency, Fig. 573, it is clear that the only part which will suffer the red light to come through is the transparent portion of the shield, which, it will be remembered, is red in the original. Similarly, when a green glass is used for viewing the green transparency, Fig. 574, only the ground will be seen, the shield being represented by an

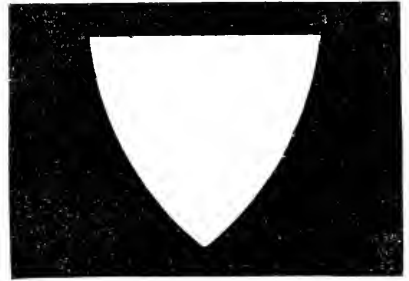

Fig. 571.—GREEN NEGATIVE.

shown by the combination of the required component colours, in the requisite proportions.

THE KROMSKOP OR PHOTO-CHROMOSCOPE.

The principle of the Ives Kromskop is illustrated by Fig. 576, which is a section through the apparatus. The pictures are

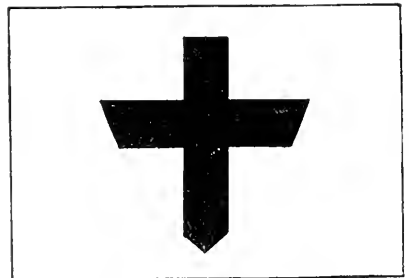

Fig. 572.—BLUE-VIOLET NEGATIVE.

viewed through the lens at A. The red glass and transparency are placed at B, the green at C, and the blue-violet at D. Reflectors of coloured glass, E E, are arranged so that they reflect the red and blue transparencies, but allow the green one to be seen through them. Another plain reflector is placed at F, to throw

light conveniently through the green transparency, and the angle of the instrument is provided for by a hinged strut fixed to the baseboard. The manner in which the light falls through the different parts of the apparatus is shown by the

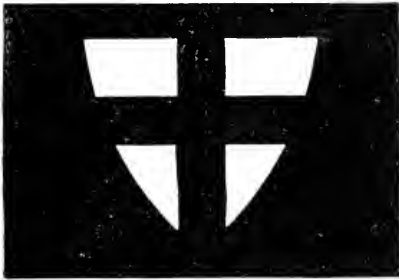

Fig. 573.—RED TRANSPARENCY.

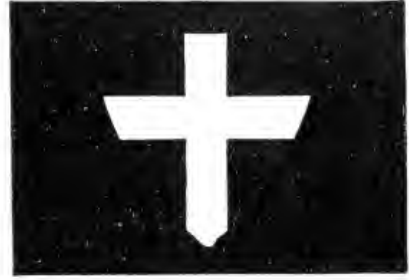

Fig. 575.—BLUE-VIOLET TRANSPARENCY.

dotted lines. The Kromskop is generally provided with two lenses, the pictures being taken in pairs, so that not only is a realistic effect of colour obtained, but the whole is seen with stereoscopic relief. Mr. Ives has also devised a triple lantern

and using the same colour screens, the apparatus is greatly simplified, so that only two, instead of three, pairs of stereoscopic images are necessary. One picture

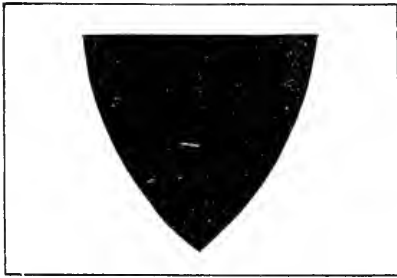

Fig. 574.—GREEN TRANSPARENCY.

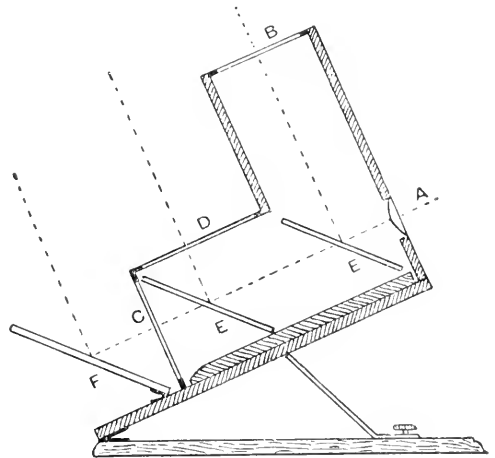

Fig. 576.—THE IVES KROM-KOP.

with three lenses and coloured glasses, by means of which pictures in natural colours may be shown on a screen. Whether seen in the Kromskop or by projection, the photographs obtained by this process are extremely truthful and beautiful, although it must be admitted that they leave the problem of direct photography in the colours of nature, at one operation, still unsolved. It is unquestionable, however, that the inventor has contributed considerably to the exact knowledge of the theory of colour.

is obtained through a blue-violet screen, one through a red, and two through green screens. This, of course, reduces the size of the plate necessary, enables the apparatus to be of simpler construction, and requires only one mirror instead of two. The instrument and accessories are shown by Fig. 577; A is a frame containing the

three colour screens; B is an attachment which fits into the camera back, carrying the colour screens and dark-slide when making exposures; while C is the viewing apparatus itself. The process can be worked with almost any quarter- or half-plate camera having the focussing adjustment in front.

THE JOLY PROCESS.

In the process introduced in 1895 by Professor J. Joly, of Dublin, only one negative is necessary. A "taking screen" is used, which is ruled closely with ex-

EXPOSURE, DEVELOPMENT, ETC.

In making the exposure, an orthochromatic screen is required to cut off the excess of blue and ultra-violet rays. As, in addition, the taking-screen before the plate obstructs a good deal of light, this must, of course, be allowed for. Development is carried out as for an ordinary negative, the aim being to obtain a result clear, soft, and full of detail, yet not lacking in vigour. As colour sensitive plates are employed, greater care in development is necessary, the work having to be performed in semi-darkness.

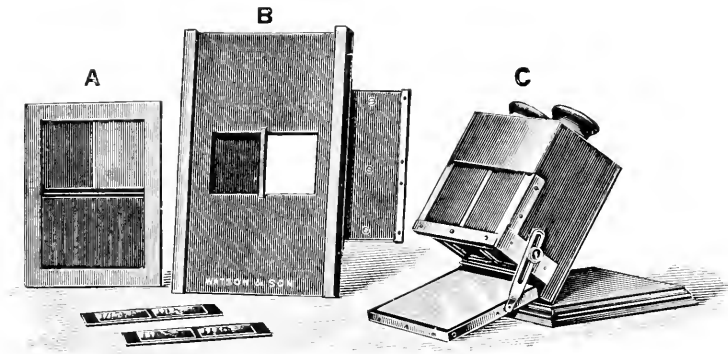

Fig. 577.—THE KROMAZ AND ACCESSORIES.

tremely fine lines of red, green, and blue-violet alternately. This is placed in front of the plate, and in close contact with it. A little reflection will show that these lines will stop all light except that of their own colour from reaching the plate. For example, the rays coming from a red object will pass through the red lines, but will be absorbed and prevented from passing the green and blue-violet lines; in consequence of which they will only affect the plate immediately behind the red lines of the screen, the same thing taking place as regards the other two colour sensations. When, therefore, a negative is obtained in this manner from a coloured original, the different tints are represented by fine lines of varying degrees of opacity, according as the light has been suffered in greater or lesser degree to pass through the various lines of the taking screen.

The negative having been secured, a positive is made from it in the usual manner, which should be clear and bright.

THE VIEWING SCREEN.

In order that the transparency may be seen in its correct colours, a "viewing screen" is necessary, ruled in three colours similarly to the taking screen, but differing as regards the tints used, since the latter has to be adjusted to suit the plate, whereas the viewing screen must be ruled with those exact colours which will give a truthful impression to the eye. The positive is placed in contact with the viewing screen, so that the lines register correctly; the two may then be bound together, if desired. Great care is necessary that the viewing screen and positive are exactly adjusted, since if the

colours fall over the wrong lines it is obvious that the result will be entirely falsified.

REMARKS ON THE JOLY PROCESS.

The late James McDonough, of Chicago, appears to share with Professor Joly the honour due to the discovery of this process, and was responsible for sundry improvements and modifications. The great disadvantage of the method lies in the fact that, unless the lines are ruled with extraordinary fineness and closeness, they are disagreeably apparent. It is quite possible to obtain screens of the desired quality, but they are necessarily expensive. The process is otherwise remarkably simple and free from complications, and is peculiarly suited for the making of lantern slides and transparencies, although for the former purpose it is desirable that the degree of enlargement should be limited.

THE SANGER-SHEPHERD PROCESS.

The process of colour photography introduced by E. Sanger-Shepherd is intended primarily for lantern slides and stereoscopic transparencies. Three negatives are taken, through red, green, and blue-violet filters, and from these coloured transparencies are made, which are bound together in register, so that only an ordinary lantern is necessary for projection, or, in the case of the stereoscopic pictures, simply the usual stereoscope. It should be explained, in order that this process may be properly understood, that coloured lights and coloured pigments do not behave in the same manner when combined. For example, as previously demonstrated, if three lanterns are used to throw red, green, and blue-violet light respectively upon the same screen, white light will be the result; whereas, if red, green, and blue-violet paints are mixed together on paper, something resembling black will be the consequence. Again, red and green lights will produce yellow, but the mixture of similar paints would have a very different effect. If, however,

red and green glasses were placed together in one lantern, the result would no longer be yellow, but a mixture similar to that produced by the pigments.

EXPLANATION OF COLOURS PRODUCED BY PIGMENTS.

The reason for the different behaviour of mixed pigments to that which theoretically would be expected may be rendered clearer by a further example. Take, for instance, the mixture of yellow and blue paints, producing green. The yellow pigment absorbs the blue-violet rays of light, and the blue absorbs the red. The only rays, therefore, returned to the eye are the green rays, and the mixed paints accordingly appear of that colour. Now, however, consider the case of similarly coloured lights, thrown together on a screen by different lanterns. The yellow glass cuts off the blue, but allows the red and green rays to pass; the blue glass cuts off the red, but passes the blue-violet and green. It is therefore seen that the two glasses between them pass all the rays necessary for the production of white light, which is accordingly seen. Stress has been laid upon these facts in order that it may be understood why, in the Sanger-Shepherd process, the three transparencies which are bound together are not, as might be expected by the precedent of the Ives process, red, green, and blue-violet, but three totally different colours.

THE THREE TRANSPARENCIES.

Red, green, and blue-violet colour filters or screens for taking the three negatives in the Sanger-Shepherd process are obtainable, adjusted for use with the Cadett Spectrum plate, and the exposure and development present no special features. With a lens working at $f/8$ in a good studio light, the red filter will require about 16 seconds, the green 8 seconds, and the blue-violet 4 seconds, under average circumstances. The plates are developed in the ordinary way, preferably with metol; and softness with plenty of detail and

gradation should be aimed at. It is, however, in the three positives or transparencies that the distinguishing features of this process are first met with; these being greenish-blue, pink, and blue-violet respectively. The greenish-blue transparency is obtained by making a black lantern slide from the red filter negative, and converting this into a greenish-blue image by means of a special solution. The positives from the green and blue-violet negatives are printed on a specially prepared celluloid film coated with gelatine containing silver bromide. This is sensitised by immersion in a solution of potassium bichromate for three minutes and dried, or it may be obtained ready sensitised if preferred. The two prints are exposed simultaneously under the two negatives, the celluloid side of the film being placed in contact with the negative, until all the details are apparent as a brownish-yellow image, somewhat resembling an undeveloped platinotype print.

DEVELOPING AND STAINING THE FILM.

The film is now removed from the frame and immersed in warm water, when the unexposed gelatine will be dissolved, leaving a white image. The two prints are next fixed in clean hypo. to remove the silver bromide, leaving a transparent low-relief in gelatine. The film is then washed for ten minutes, and is ready for staining. Up to this time the prints from the green and blue-violet negatives have remained on the same strip of film, for convenience; but this is now cut in half, since the prints must be stained to different colours. The print from the green negative is stained pink in a bath containing a special dye, and the print from the blue-violet negative is stained yellow. Suitable dyes are supplied in concentrated form, merely requiring dilution with four or five times their bulk of water. The films are then dried, being finally mounted in superposition on the blue transparency, and bound in position, a mask and cover-glass being used as in making ordinary lantern slides. A more brilliant result is obtained if the films are mounted in op-

tical contact by means of Canada balsam, the improvement being well worth the trouble. In any case, great care must be taken to secure exact registration. By a modification of this process the colouring matter contained in three stained gelatine reliefs is transferred successively to a single sheet of gelatinised paper, thus enabling photographs in colour to be obtained on a paper base.

THE LUMIÈRE PROCESS.

The process of colour photography due to MM. Auguste and Louis Lumière, of Lyons, is founded on principles laid down by Cros and Ducos du Hauron. Three colour screens or light filters are required, green, blue-violet, and orange. These may be obtained commercially or made as follows:—Glass optically worked is coated evenly with a 10 per cent. solution of gelatine, which has been carefully filtered, allowing one dram of the gelatine solution to each square inch of glass. These must be dried on a level surface in a place perfectly free from dust. When thoroughly dry, they are immersed in the following staining solutions, which must be first carefully filtered:—

STAIN FOR GREEN SCREEN.

Solution of methylene blue X, $\frac{1}{2}$ per cent.	$\frac{1}{2}$ oz.
Solution of auramine G, $\frac{1}{2}$ per cent.	3 oz.

STAIN FOR BLUE-VIOLET SCREEN.

Solution of methylene blue X, $\frac{1}{2}$ per cent.	2 oz.
Water	1 oz.

STAIN FOR ORANGE SCREEN.

Solution of erythrosine, $\frac{1}{2}$ per cent.	9 drs.
Saturated solution of metanile yellow at 60° F.	10 drs.

The screens should be left in the dyes for five minutes at a temperature of 70° F. They are then rinsed and carefully dried. When dry, two of each tint are cemented together with Canada balsam, the edges being bound with gummed tape. Roughly speaking, the exposure necessary with the green and orange screens will be twelve times that required with the blue-violet one, which must be found by experiment.

EXPOSURE AND DEVELOPMENT.

Three negatives are made through the three screens, on suitable plates as recommended for the process, and from these three prints are obtained on a special paper coated with bichromated gelatine and glue. The prints are developed with water, in practically the same manner as the carbon process, and when dry are dyed respectively red, blue, and yellow. Care should be taken not to mix the positives, and it is a wise precaution to mark them. The positive printed from the green negative is dyed red; that from the blue-violet negative, yellow; and that from the orange negative, blue.

THE DYEING BATHS.

The dyeing baths for the positives are made to the following formulæ:—

RED BATH.

Water... ..	200 parts.
Solution of erythrosine J, 3 per cent.	5 parts.

BLUE BATH.

Water	200 parts.
Solution of pure diamine F, 3 per cent.	10 parts.
Solution of hard glue, 15 per cent.	14 parts.

YELLOW BATH.

Water	500 parts.
Chrysophenine G	2 parts.
Dissolve at 160° F., and add alcohol	25 parts.

At ordinary temperatures, the prints should remain in these dyes for about 12 hours; they are then washed for a short time to remove the excess of colour and dried. It is advisable, before drying the red and blue positives, to give them a brief immersion in a 5 per cent. copper sulphate solution, and rinse.

SUPERIMPOSING THE FILMS.

The three positives are now temporarily placed together, in order to see if they give a correct rendering of the original. If all is found to be satisfactory, the three

films are stripped one by one from their supports, on to a single temporary paper support, taking care that they register properly with each other, and securing adhesion by means of a gelatine mountant. Each film must be allowed to dry before applying the paper to another. When the three films are stripped and in superposition, the picture is finally transferred to a glass support, the temporary support of paper being removed, leaving a transparency in colours on the glass. An advantage of this process is that corrections may be made in the colours, if they are not approved, by reducing the transparencies, or giving them a further immersion in the dyeing bath. Small local alterations of parts too highly coloured may be made with a moist brush. The blue transparency, however, cannot be treated in this way, but the colour may, if necessary, be reduced by a solution of gelatine or glue of from $\frac{1}{2}$ to 1 per cent. in strength. After any alterations have been made, the red and blue transparencies should be immersed in the copper sulphate solution as before, rinsed, and dried. The whole of the materials necessary for the process, with detailed instructions, are commercially obtainable.

A NEW LUMIÈRE PROCESS.

A new and highly ingenious process of colour photography has recently been described by MM. Lumière before the French Academy of Sciences. Potato starch granules having a diameter of from $\frac{1}{15,000}$ to $\frac{1}{10,000}$ of a millimetre are stained in three colours, red-orange, green, and violet. The coloured powders thus obtained are mixed together and spread upon glass. After isolating the colours with a varnish, the plate is coated with a panchromatic emulsion. Exposure is carried out in the ordinary manner, but with the glass side of the plate facing the lens, so that the light has to pass through innumerable microscopic colour screens, formed by the potato grains, before reaching the sensitive film. The result can be readily understood; the light only passes through those grains which correspond to its own colour, thus producing,

on development, opaque grains of silver which prevent that colour from being seen, so that a negative is obtained in colours complementary to the original. This can be used to produce a positive in correct tints, by exposing in contact with another plate prepared in a similar manner; or, if preferred, the negative may be reversed by dissolving the reduced silver after development, but without fixing, and then developing the previously unexposed silver, after the manner of the *contretype* process. This method has hardly yet been entirely perfected, but would appear to offer a satisfactory means of obtaining colour photographs on one plate with a single exposure, besides having the advantage that any number of copies could be made from the original negative.

THE DIFFRACTION GRATING PROCESS.

The Diffraction Grating Process is the invention of Professor R. W. Wood, of Madison, U.S., and is entirely distinct

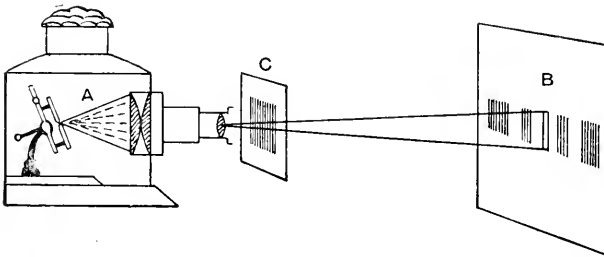

Fig. 578.—ACTION OF DIFFRACTION GRATING.

in principle from any of those previously mentioned. A diffraction grating, it should be explained, consists of a sheet of glass or metal ruled with a very large number of fine parallel lines, at equal distances from each other, and has the property of splitting up white light into its constituents, very similarly to a glass prism. If a lantern, A (Fig. 578), is used to throw a beam of light through an opaque slide having a narrow slit or clear space of glass, an image of the slit will appear on the screen at B. If, now, a glass diffraction grating, C, is placed between the lens and the screen, the white

image of the slit will still remain, but on each side of it will appear the colours of the spectrum, as shown by the diagram. There are, in fact, a series of spectra, instead of only one, as when a prism is used.

EFFECT OF FINENESS OF RULING.

The extent of the diffraction and the distance of the spectra from the image of the central slit depend upon the fineness with which the screen is ruled, which fact is turned to advantage, as will now be shown. If a small hole were made in the lantern screen, just where the violet portion of the spectrum was visible, and the eye were applied to the aperture behind, looking towards the illuminated grating, the latter would appear entirely violet. Or, if the hole were made instead in the red part of the spectrum, and looked through as before, the grating would seem to be all red. Now, as before explained, since the amount of diffraction and the position of the spectra in relation to the central slit vary with the closeness of

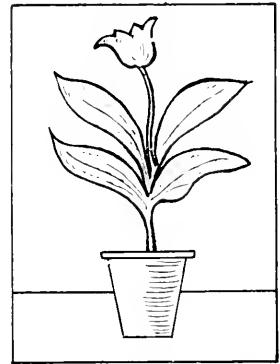

Fig. 579.—SUBJECT FOR DIFFRACTION GRATING PHOTOGRAPH.

the grating, it is evident that if the first grating were to be removed, and one with the lines ruled closer together or farther apart were substituted, the eye applied to the opening in the screen would no longer see the same colour as before, but a different one, because the spectrum would have shifted its place on the screen. For instance, with gratings ruled with 2,000, 2,400, and 2,750 lines to the inch, as used

PRINT FROM YELLOW BLOCK ONLY.

PRINT COMBINING YELLOW AND RED.

by Professor Wood, if the hole in the screen is made in the red portion of the spectrum obtained with the coarsest grating, the green rays will come over the opening if the intermediate grating is used, and the violet would be seen on replacing it with the finest ruling.

will actually be seen when such a picture is looked at from the correct point of view. It is on this principle that the process is founded. Three negatives are first taken through red, green, and blue-violet screens. Suppose the subject is such as that shown by Fig. 579, which represents

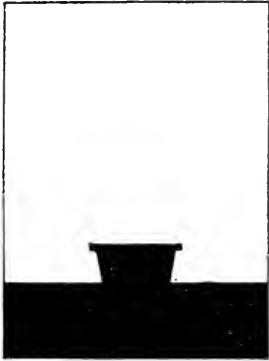

Fig. 580.—RED NEGATIVE.



Fig. 581.—GREEN NEGATIVE.

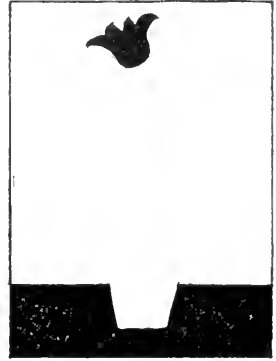

Fig. 582.—BLUE-VIOLET NEGATIVE.



Fig. 583.—RED TRANSPARENCY.



Fig. 584.—GREEN TRANSPARENCY.



Fig. 585.—BLUE-VIOLET TRANSPARENCY

APPLICATION OF THEORY TO PRACTICE.

If only part of a grating were ruled instead of the whole, that part would appear coloured. It is clear, therefore, that if the different parts of a picture are represented by lines of a fineness corresponding to that required to show a given colour when viewed from a certain standpoint, a picture in those colours

a red flower-pot standing on a white cloth, and containing a blue flower with, of course, green leaves, the background being black. The three negatives obtained from such an original would resemble Figs. 580, 581, and 582 respectively. From these negatives ordinary transparencies are made, which will appear like Figs. 583 to 585 inclusive, but showing the gradations of the original subject.

OBTAINING THE DIFFRACTION PHOTOGRAPH.

A piece of glass coated with bichromated gelatine is then placed in contact with a grating ruled, say, with 2,000 lines to the inch, and over this is laid the red transparency. The three are then exposed to light, with the result that an image of the grating is obtained on the bichromated plate in those parts only which are transparent in the negative. The red portions of the picture will therefore be represented on development by a grating image of 2,000 lines to the inch. The plate, however, is not yet developed, but is again exposed: this time in contact with a grating of 2,400 lines to the inch,

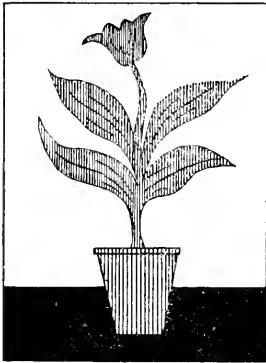

Fig. 586.—DIFFRACTION GRATING PHOTOGRAPH.

and using the green transparency. Finally it is exposed, with that having 2,750 lines to the inch, under the blue-violet positive. The plate is then developed in water, and a picture is obtained, in which the different parts of the original are rendered by a microscopic series of lines, varying in fineness and intensity with the tints and gradation of the subject. This is illustrated roughly by Fig. 586, where the lines are intentionally drawn with greatly exaggerated thickness and spacing. Compound colours will be rendered in combinations of the different rulings, black will be shown by clear glass, and white will display the rulings of all the three gratings. Occasionally, the different rulings overlap and interfere with each other; this, however, seldom occurs.

COPYING THE POSITIVES BY PROJECTION.

The method of copying the positives by laying them in turn over the gratings above the sensitive plate does not give the best results, since the thickness of the glass prevents the image being sharp. Another plan, therefore, is generally adopted. This consists of placing the transparencies, one by one, in a lantern, and focussing their images sharply on the three gratings, which are caused to place themselves in turn before the sensitive plate by means of a sliding frame or carrier (Fig. 587). It is thus secured that the gratings and transparencies will be

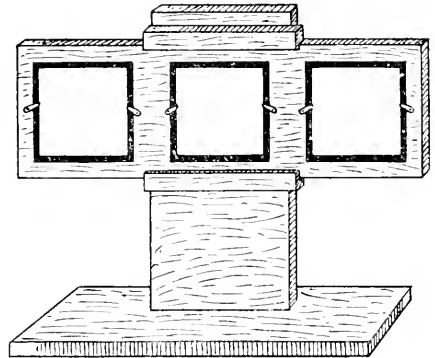

Fig. 587.—SLIDING FRAME FOR DIFFRACTION GRATINGS.

equally sharp in the result. A yellow glass is used during the various adjustments, to enable the different pictures to be placed in correct registration with each other, without meanwhile affecting the plate.

METHOD OF VIEWING.

The pictures obtained are colourless and almost imperceptible when looked at in the ordinary way. In order for the colours to be seen, they must be lit in a particular fashion and examined through a small aperture, so placed that the eye is in a correct position for viewing. The apparatus devised for the purpose by Professor Wood is shown by Fig. 588. It consists of a stand carrying at one end

a metal plate with two eyeholes, and at the other a support to take the diffraction photograph, behind which is fixed a double-convex lens. The necessary illumination must be obtained from a narrow slit parallel with the lines of the gratings. An incandescent mantle at some distance from the picture will give satisfactory results, or the filament of an electric lamp placed sideways is very suitable. At first, these pictures were arranged to be viewed with one eye only, a manifest disadvantage; but later it occurred to the inventor that as two spectra were formed by the grating, one on each side of the central line, it should be possible to use both eyes at once if the two openings were placed so that one eye should see the first spectrum and one the other, which is now done. A suggestion due to Mr. F. E. Ives is that the lines of the gratings should be used horizontally instead of vertically, when the pictures could be inspected through a horizontal slit, and the eyes might be moved in any direction along the line without the colours appearing different. This plan would have the advantage of being suited to any pair of eyes, for it is a well-known fact that these are not always the same distance apart in various individuals. Professor Wood has now succeeded in modifying the apparatus so that two gratings can be viewed at once, thus enabling the pictures to be seen stereoscopically.

REPRODUCTION OF THE POSITIVES.

Any number of copies of a diffraction photograph may be obtained by printing in contact on a film of bichromated gelatine. A curious feature of the process is that a positive picture is always secured from a positive by one operation, no negative being required; since the lines and spaces of the original are reproduced at similar distances, and that is all that is necessary. The image, although scarcely visible, and certainly not possessing anything of what is known as photographic density or gradation, is nevertheless copied faithfully as regards all its rulings in microscopic

furrows and ridges of gelatine, by means of that very diffraction of light which enables the finished picture to be seen in the colours of nature. This ready reproduction of diffraction photographs is manifestly a decided and unique advantage.

THE BLEACHING-OUT PROCESS.

In this process, first suggested by Charles Cros in 1881, a mixture of dyes in gelatine is spread over paper or glass,

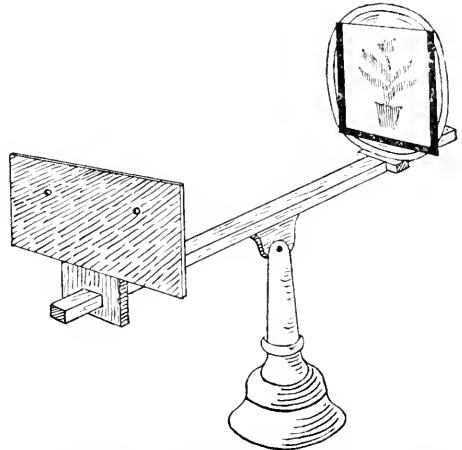

Fig. 588.—ARRANGEMENT FOR VIEWING DIFFRACTION PHOTOGRAPHS.

and exposed under a coloured transparency. The dyes are bleached out, except under those portions of their own colour, and a coloured reproduction of the original is obtained. The method proposed by Cros involved the use of three separately stained films superimposed; but later investigators have demonstrated that the three dyes may be incorporated in one film. Dr. Neubauss, who has greatly improved the process, recommends the following mixture for sensitising plates or paper:

Soft gelatine	90	grs.
Water (distilled)	2	$\frac{1}{10}$ oz.

Soak the gelatine in the water for one hour, then melt on a water-bath and add:

Solution methylene blue,	0.2	per	
cent.	60 minims.
Alcoholic solution auramine,	0.2		
per cent.	25 minims.
Solution erythrosine,	0.5	per cent.	30 minims.

The mixture, after filtering, is spread upon glass or enamel paper and allowed to dry. Before exposure, the plates are treated with an ethereal solution of hydrogen peroxide. Ten minutes under a coloured transparency, followed by soaking in water, is generally capable of giving the desired result. Szczepanik, of Vienna, has patented a process on much the same principle, but differing in detail. Herr Worel, of Gratz, has also done successful work in this direction, but prefers to withhold his methods from the public.

POSSIBILITIES OF THE BLEACHING-OUT PROCESS.

According to Dr. Neuhauss, there are certain dyes which, under special circumstances, can be made to lose their colour, but regain it on exposure to light of a complementary colour. It is clear that if fuller information could be obtained on this subject, and dyes of sufficiently rapid action were procurable, negatives in complementary colours might be made by this means, from which positives could be secured in correct tints by a second exposure on a film prepared in a similar manner. This would obviously afford a perfect solution of the problem of colour photography. At present, however, there are no clues apparent as to how this desirable consummation may be reached.

THE HALF-TONE TRICHROMATIC PROCESS.

Attempts have, at various times, been made to secure the reproduction of colour photographs in the printing press, by one or other of the photo-mechanical processes. Collotype was tried, but proved commercially unsatisfactory, since hardly any two impressions could be produced alike, owing to the difficulty of obtaining an equal depth of printing from each of the three plates employed. Photogravure would be too expensive for the purpose, so that experimenters were driven finally to seek a solution of their difficulties in the half-tone process. This has been very successfully adapted for three-colour

printing, and some very beautiful results are now obtained. Three negatives are first made through colour screens, and from these transparencies are secured on collodion or process plates. It is now only necessary to make three separate half-tone blocks, in the ordinary manner, from the three transparencies, and to print from them in superposition, using suitably coloured inks.

INITIAL DIFFICULTIES OF THE PROCESS.

One of the first obstacles encountered in the attempt to print in colours from three half-tone blocks was as follows:—It was found that when the lines of the several screens were placed one over the other, a curious pattern or "watered" effect was caused, which quite ruined the appearance of the picture. To Mr. Ives is due the suggestion which enabled this difficulty to be overcome. In making the blocks from the transparencies, three screens are used, having their lines disposed at different angles, so that the lines of one screen make an angle of 60° with those of another. By this means the offensive watered-silk effect is entirely eliminated. The screens commonly employed for this class of work are ruled with lines running in one direction only; that is, they consist of one-half of a "cross-line" screen. Identical gradation must be obtained in the three blocks or the result will be imperfect and irritating. Nothing but the most exact and deliberate working is permissible throughout.

ADJUSTING THE COLOURED INKS.

The colour and nature of the inks used for trichromatic printing is evidently of great importance. Either the inks must be exactly adjusted to the negatives, or the colour filters and plates to the inks. The colours principally used are cadmium yellow, alizarine red, and Milori blue. Needless to say, the whole process calls for great care and nicety of treatment, and a certain amount of correction and "faking" is commonly required to secure a perfectly correct and harmonious result. Some workers prefer to make the

half-tone negatives direct through the screen on dry plates, and there are other possible variations, but the method first described is that generally regarded as the most satisfactory.

THE POWDER PROCESS.

A process introduced in 1888 by Germeuil-Bonnaud consisted of exposing a plate coated with treacle, sodium borate, and potassium bichromate, and dried, under an ordinary positive. It was then dusted with various coloured pigments, which it was claimed adhered selectively to the different parts of the picture, giving a reproduction of the colours of the original subject. It does not seem to have been generally considered that this claim for selective action of the pigments was sufficiently substantiated. Dr. A. Miethe has, however, successfully worked a variation of this idea. Glass plates are coated with the following mixture:—

Gelatine	9 grs.
Sugar candy	300 grs.
Potassium bichromate	90 grs.
Water	3½ oz.

The plates are dried by heat and exposed in the sun while warm. Three prints will be required from three negatives representing the three colour sensations. Development is performed by brushing the plates over with suitable transparent powder colours. The yellow print is made first, stripped with collodion and affixed to a card with gelatine solution. When dry, this is treated with a thin film of shellac, and the red and blue prints superimposed upon it after the same manner.

PINACHROMY.

A new process recently introduced under the above name by Dr. Koenig depends on the oxidation into colours, by exposure to light, of the colourless "Leuco" bases of certain organic dyes. Three negatives are secured through red, green, and blue-violet screens, in the usual manner, and these are printed from one after the other, in

exact register, on paper sensitised with the Leuco bases in conjunction with a specially prepared collodion vehicle. First, a print is obtained from the red filter negative on paper treated with the blue Leuco base. This is fixed in a special fixing acid, washed, dipped in a chrome-gelatine solution and dried. The blue print is next coated with the red sensitising mixture, dried in the dark, and exposed under the green filter negative, afterwards fixing and treating as before. Finally, the dried blue and red print is coated with the yellow sensitiser, dried, and exposed under the blue filter negative, when, after fixing, washing and treatment with the chrome-gelatine solution, the picture is finished and may be allowed to dry. It is, of course, necessary to carry out each coating, etc., in light of a particular colour. Varnishing is recommended as a protection against abrasion. The colours obtained from the light-affected Leuco bases are said to be extremely rich. The materials for working this process, which, though it involves many operations, is by no means difficult, will shortly be commercially procurable.

THE PROGRESS OF THREE-COLOUR WORK.

Three-colour photo-mechanical work has been elaborated to a high state of perfection, as the illustrations in many of the better-class magazines and books amply demonstrate. Acknowledgment must be made of the valuable contributions to the progress of the art due to Baron von Hübl, Edmund Valenta, Leon Vidal, Dr. Eder, and others not previously mentioned. It must be admitted that the results obtained are not always truthful reproductions of the original, but this by no means prevents them from being highly artistic and beautiful, when properly executed. Success in the process seems to depend largely on the ability of the worker to make a wise compromise between the theoretically perfect and the actually possible rendering of colour. That is to say, it is often the case that colours which are really less true to the original may give a more pleasing effect than tints nearer to the

ideal, but, in practice, found not so harmonious.

OTHER PROCESSES OF COLOUR PHOTOGRAPHY.

There have been many other processes suggested for securing photographs in colours, most of which were simply fore-runners or variations of those already dealt with, and are by this time practically forgotten. In 1897 much excitement was caused in the photographie world by a process introduced by MM. Dansac and Chassagne, two French scientists, in which it was claimed that certain coloured solutions brushed in turn over a transparency or print, treated in a special manner, adhered selectively to their own proper portions of the picture, giving a correct reproduction of the original. This pretension, however, was not considered to be substantiated, it being generally agreed that the process resolved itself simply into a method of tinting prints with aniline dyes. In 1899, Mr. Wallace Bennetto, of Newquay, introduced a method whereby three negatives were taken through suitable screens at one exposure, by means of a specially constructed camera, from which coloured positives were obtained on three films of bichromated pigmented gelatine, these being then stripped and superposed. Some beautiful results were shown by the process, but little has since been heard of

it. In 1900, Hofmann, of Cologne, following a suggestion made by Ducos du Hauron in 1867, perfected a process in which prints are made on three carbon tissues, containing red, yellow, and blue pigments, and squeegeed into adhesion over each other. That prolific inventor, Szczepanik, has also been responsible for sundry other ingenious methods of colour photography besides that principally associated with his name, and previously mentioned.

CONCLUDING REMARKS.

It is, of course, impossible, in the space at disposal, to enumerate every system that has been proposed for securing photographs in natural colours. The subject is a large one, and might well require an encyclopædia to itself. All the leading processes as at present worked have, however, received detailed explanation, and much matter of historic interest has been included. From what has been said, it will no doubt be gathered that, although absolute success has not yet been attained, so far as regards a colour process as simple and certain in practice as the taking of an ordinary negative, yet sufficient progress has been made to remove any ground for discouragement. With the amount of knowledge at present in hand it is by no means improbable that the coveted secret of rivalling, by direct photography, the glowing tints of the painter will one day be unravelled.

ORTHOCHROMATIC PHOTOGRAPHY.

INTRODUCTORY REMARKS.

ORTHOCHROMATIC photography is the art of translating coloured objects into monochrome with the colours properly repre-

vised. Why is this? Because the plate is less sensitive to the yellow rays, or those vibrations which cause the sensation of yellow, than it is to the blue rays, or those vibrations which excite the blue nerve. It



Fig. 589.—VISUAL LUMINOSITY OF SPECTRUM.

sented in their varying degrees of brightness, these being reproduced by shades of the same contrast in gradation. As is generally known, the photographic plate does not render all colours of the same relative intensity as seen by the eye. For example, if some yellow flowers placed in a dark blue vase are photographed, the flowers will appear much darker than the

should be remembered that a beam of white light consists of all the colours in nature. These colours may be separated by allowing a beam of white sunlight to pass through a slit in the shutter in a dark room, and causing them to fall upon one face of a triangular prism and pass out on the other side. The light rays will be bent, but not equally, and thus a series

of overlapping images of the slit, each of a different tint, will be formed. The degree of dispersion or separation will be dependent on the density of the glass, as well as on the angle of the prism, and it therefore follows that the purity of the colour will depend upon the width of the slit. The narrower the slit the purer the colour, as there will be less overlapping of the images.

MEASUREMENT OF COLOUR INTENSITIES.

By an ingenious invention of Sir W. Abney, any of the intensities of the various parts of the spectrum can be measured. The proportionate brightness of the different colours may be represented by a curve, as shown in Fig. 589, which pro-

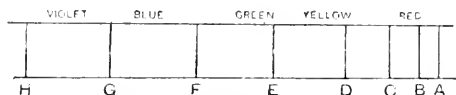

Fig. 590.—DIAGRAM OF SPECTRUM.

vides a most striking comparison of the relative visual intensities. The highest point reached by the curve represents the brightest or most luminous part of the spectrum. The blending of colour is so delicate that in ordinary circumstances it would be exceedingly difficult to locate any particular part of the spectrum: but fortunately, at certain points, lines occur which are due to the presence of such metals as sodium, lithium, strontium, etc. These serve as guides, as they always appear in the same place provided the same prism is used, thereby affording a ready means of identifying any particular part of any colour. Each line has been given a letter; the D line, for example, always comes in the yellow, and occupies exactly the same place. The H line comes in the violet. The position of two such lines being found, the remainder of the spectrum may be readily plotted. Fig. 590 gives a diagrammatic representation of the spectrum. For such accurate observation it is necessary to use a spectroscope, an instrument extremely useful to the scientific photographer.

SPECTRO-PHOTOGRAPHY.

As spectro-photography is dealt with in another section, only a brief description need be given here. The apparatus is shown in Fig. 591, and consists of an adjustable slit A at one end of a tube B, which carries a lens C capable of focusing rays a mile or so away, thereby rendering them practically parallel. This tube, which is of the same length as the focus of the lens, is called a collimator. On a revolving table D is a glass prism or series of prisms E E: for this work a quartz prism is preferable, as it transmits

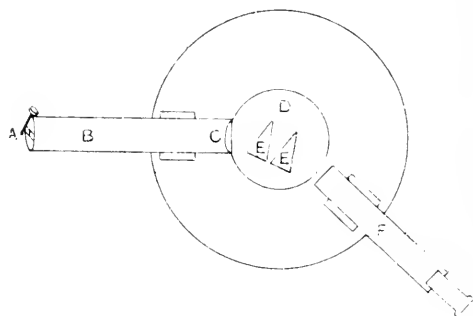

Fig. 591.—SPECTROSCOPIC APPARATUS.

more of the ultra-violet rays, but a glass prism answers very well. F is a telescope capable of focussing the spectrum, and allowing certain parts of it to be examined critically. If a photograph is taken of the spectrum thus formed, and the proportionate densities of its different parts accurately measured, it will be interesting to compare the curve which may be worked out from such a result with the visual curve above described. This curve will closely resemble that shown in Fig. 592. By comparing these curves a better impression may be obtained of the falsity of rendering to which the plate is liable under ordinary conditions. It will at once be seen that while the red and yellow have practically no effect, the blue and violet have proportionately too much action, whilst beyond the extreme limits of the violet will be found a similar action going on, apparently without light, but really due to the invisible ultra-violet or chemical rays.

PHOTOGRAPHING SPECTRA.

By allowing the spectrum to fall upon a gelatine film containing one of the silver haloids, and then submitting it to development, a very clear idea of the sensitiveness to the different coloured rays of each haloid is obtained.

Silver chloride.—This haloid is found to be most susceptible to that part of the spectrum containing the dark violet rays H (Fig. 590), consequently the greatest deposit of silver is

DYES AS COLOUR SENSITISERS.

It is evident, from the facts mentioned above, that the haloids of silver are most sensitive to the dark violet and blue rays of the spectrum. The human eye, however, is most sensitive to the yellow and red rays, and in order to make photographic intensity identical with visual intensity, which is the object of orthochromatic photography, the silver haloids must be made more sensitive to these rays. The first step in this direction

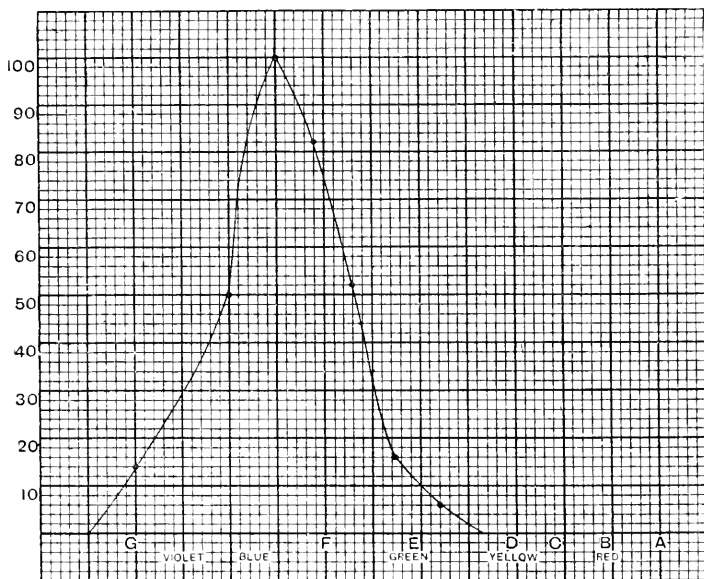

Fig. 592.—SPECTRUM CURVE ON ORDINARY PLATE.

found here. The deposit ceases a short distance past the line F, but continues for some way on the other side of the line H.

Silver bromide.—The film containing this haloid gives the greatest deposit of silver, after development, on that portion affected by the blue rays between G and F. It then gradually diminishes towards the red end of the spectrum, ending at the line D, but continuing on the other side of G, some distance past H.

Silver iodide.—A film of this compound produces the greatest decomposition when under the rays, represented by the Fraunhofer line G. The deposit of silver ceases just after the line F, but, like the chloride and bromide, continues for some distance past H.

was made in 1873 by the important discovery of Prof. Vogel, that certain organic colouring matters increased the sensitiveness of these silver compounds to the greenish-yellow and yellow parts of the spectrum. He found that by merely immersing the film in a weak solution of the dye the haloids of silver were rendered susceptible to parts of the spectrum hitherto without any action.

CORRECTING FALSE EFFECTS OF COLOUR.

Now suppose another photograph is taken of a spectrum, and in this case it is greatly over-exposed (on the principle explained in the section on "Exposure of the Photographic Plate," where it was stated

that only a certain proportion of light intensities can be represented on the plate, after which a reversal occurred). It will be found that this falsity of rendering may be overcome to some extent, but only by the alteration of the gradations. Suppose an ordinary plate is taken and bathed in the dark with a solution of erythrosin, dried, and afterwards submitted to the same test exposure in two sections to ensure accuracy in position. The curve given by such a plate will

"screen," which lessens the activity of the energetic vibrations.

THEORIES REGARDING ORTHOCROMATISM.

The colouring matters most effective for rendering films orthochromatic are, Eosin, $C_{20}H_6Br_4O_5K_2$; Erythrosin, $C_{20}H_6I_4O_5K_2$; and Rose Bengal, $C_{20}H_2Cl_4I_4O_5K_2$, belonging to the family of the phthaleins; and Quinoline Blue or Cyanin, $C_{29}H_{35}N_2I$. These, it will be noticed, are compounds of

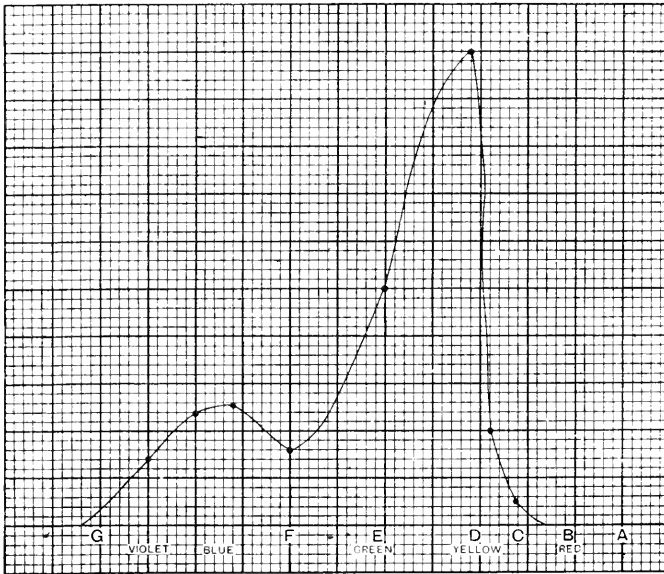

Fig. 593.—SPECTRUM CURVE ON ORTHOCROMATIC PLATE.

be approximately that shown in Fig. 593, which more nearly approaches to Fig. 589. Exposing the plate in two sections, the first one should show the locality lines. Then let a further experiment be made of placing a piece of lemon-yellow glass in the path of the rays, the object of this being to entirely cut out the ultra-violet, which in any circumstances must give a false effect, and to tone down the excessive activity of the blue. Thus, it will be seen, there are two influences at work: (1) the dye, which raises the sensitiveness of the plate to the less active rays; and (2) the yellow glass or light filter, also called a

great molecular complexity. As dyes they are very fugitive, and are readily oxidised in the presence of light to colourless compounds. Also it has been shown that their sensitising action is considerably increased in the presence of ammonia. Abney found that it was not necessary to dye the film in order to render it orthochromatic, because the same effect is obtained by coating the film with a varnish containing the colouring matter. With regard to the action of dyes on the sensitive film, it may be said that no satisfactory theory has yet been established; the various statements to be found in the text-books are purely conjectural. As is the case when considering

the latent image, the opinions dealing with this matter may be broadly divided into two classes, physical and chemical. Eder, after a painstaking study of a very large number of colouring matters, comes to the conclusion that no definite connection is to be found between the sensitising action of dyes and their chemical constitution.

VOGEL'S HYPOTHESIS.

According to Vogel's original idea, the particular coloured light absorbed by the dye is transferred to the silver salt in its immediate neighbourhood for a much longer time, comparatively, than would be the case if the dye was absent. For instance, a red light which, in the ordinary way, would have no action on the silver salt, would be trapped, as it were, by the dye, and so made to perform a certain amount of work. This view would lead to the conclusion that the action of the dye was quite separate and of a purely physical nature. Eder, however, found that the particles of silver salt were actually stained by the dye, and if once associated with the haloid could only be removed with difficulty. For example, a dyed film can be washed till colourless, yet such a plate is still orthochromatic. Evidently the dye enters into a very intimate molecular combination with the haloid. Eder considers the dye forms a compound with the silver salt after the nature of a "lake." A "lake," it may be pointed out, is an insoluble complicated *salt* formed by the union of a dye with an inorganic compound.

ABNEY'S HYPOTHESIS.

Abney considers the action a purely chemical one. On this idea the colouring matter is supposed to undergo photo-chemical oxidation, and the products of this oxidation then act as reducing agents, in the intermediate neighbourhood of the absorption, and so assist the reduction of the silver haloid. Vogel's observation, that the less stable the colour, the more readily it acts as a sensitiser, goes to prove that the dye, like other sensitisers, acts chemically.

Some further information on this subject will be found in the sections on the "Chemical Action of Light" and the "Theory of the Latent Image."

EXPERIMENTS WITH ARTIFICIAL SPECTRUM

Those who cannot arrange for experiments with the spectrum will find that some very useful work may be done with an artificial spectrum made up with strips of coloured glasses. Take, for example, strips about $\frac{1}{2}$ in. wide and $\frac{3}{4}$ in. long of white, violet, blue, green, yellow and red glasses, and lay them side by side across a piece of clear glass quarter-plate size. Strips of lantern slide binding across the top and bottom will serve to hold them all firmly together. When this has been arranged, some strips of translucent paper should be cut and pasted one over the other on those colours which appear brightest, until all the colours appear of equal depth. Fixed plates immersed in aniline colours are best for forming the coloured glasses. Now expose an ordinary plate behind this, when a variety of deposits will be produced altogether wrong in values. An orthochromatic plate should now be exposed in the same way, giving a better but still imperfect result. A similar plate may now be exposed behind the glasses, in this case fronting it with a light filter, as shown in Fig. 594. This is filled with a solution of aurantia, and may be screwed up so as to lessen the thickness and reduce the depth of tint. The rubber in between the glasses of the filter must be exceedingly soft, or they will be cracked. When the tint which gives the best result is found it may be matched by comparison with a printed scale of tints to be described later.

DETERIORATION OF SCREENS.

It may be remarked here that colour screens and light filters are subject to deterioration if exposed much to the light, and sometimes even spontaneously. It therefore becomes necessary to test them with the spectroscope, from time to time, if the most exact results are required. It is often the case that workers unaware of this are puzzled by the apparently contradictory results obtained with a formerly satisfactory screen.

FALSE EFFECTS NOT ALWAYS APPARENT.

It may be stated that in the majority of common subjects the falsity of rendering is not very apparent, even to the critical eye, owing to the amount of white light which most objects reflect; so that by making use of the principle embodied in the above experiment, either wholly or partly, it is possible to obtain an approximately accurate rendering under most circumstances. It should be understood that colour is merely a physiological impression, and distinct from luminosity; that is to say, red, yellow, or blue may be of a variety of intensities. It would therefore be quite possible to shade down the yellow to the same intensity as the blue, so that a photograph taken of both shows the same density for each colour. The plate is not sensitive to colour at all, being practically colour-blind.

PERFECT RENDERING OF COLOURS IN MONOCHROME IMPOSSIBLE.

From this it will be seen that contrast of colour, of itself, can never be properly rendered in monochrome, either by photography or any other method. In painting or drawing it may be possible to differentiate between the colours by altering the direction of the line, or by similar methods: but in photography, where the operator is tied down to a certain set of gradations, it is impossible to alter the gradations between colours without disturbing the whole scheme of light intensities, when the balance of light and shade would, of course, be false, as compared with the original, throughout the whole of the picture. It is possible, in some circumstances, such as when the light intensities are equal, that the ordinary plate may be preferable to the orthochromatic plate; but this rarely occurs. Furthermore, no method of dyeing the plate has been discovered which will alone raise the sensitiveness of the red and green to equal that of the blue and violet, and the use of the screen lessens the certainty to some extent, from a practical point of view.

PANCHROMATIC PLATES.

Plates may be made sensitive throughout the spectrum, the "Lumière Panchromatic" answering to this description. These are least sensitive to the green, although fairly sensitive to the extreme red. For development, therefore, a green light should be employed. The dye may be added to the emulsion in preparation, or the plate may be treated with the dye afterwards. Different dyes render the plate sensitive to different rays. For

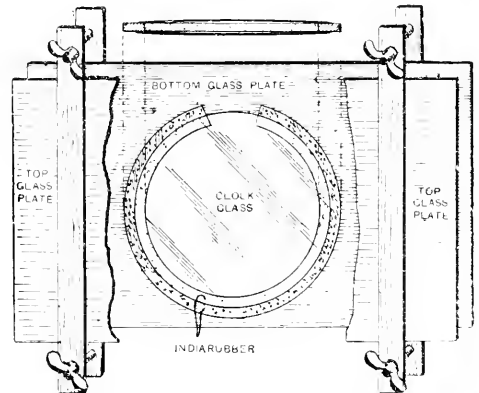

Fig. 594.—LIGHT FILTER OF ADJUSTABLE DEPTH.

example, to make a plate sensitive to yellow and yellow green, erythrosine, Rose Bengal, or eosin may be used. To increase the sensitiveness to red, cyanine, cœrulein, and alizarin blue are chiefly used.

DYEING THE PLATE.

The most suitable dye to experiment with is erythrosine, and the purer this is, the more successful will be the results. To make up a stock solution of erythrosine, take $15\frac{1}{2}$ grains of erythrosine and dissolve in 35 oz. of distilled water to form what is approximately a 1 per cent. solution. The bath may then be very easily made up whenever required by taking 1 oz. of the stock erythrosine solution and adding to it 8 oz. of distilled water. Finally drop in 1 oz. of a 10 per cent. solution of ammonia, and carefully filter the whole. An ordinary plate is taken from the box, dusted, and laid film up in the

developing dish. The above solution is then poured gently over it, and the plate allowed to remain for from three to four minutes, when it should be removed and well washed for five minutes in running water, and transferred to the drying cupboard.

RINSING THE PLATE.

Be careful that the plate is thoroughly freed from excess of dye; nothing more than this is necessary, prolonged washing being injurious. Ordinary tap water may be used for this purpose, and the plate should preferably occupy an inclined position, as there is less chance of a deposit of earthy salts, which would cause trouble in after manipulations.

DRYING THE PLATE.

The plate should be dried in an upright position, and should be placed on the shelf of a well-ventilated dark-room, the air of which may be safely regarded as free from the products of combustion. Any of the drying apparatus described in the section on "Development Processes of Printing" may be used. When the plate is required rapidly, it may be dried by immersion in methylated spirit, which should be carefully filtered before use. An alternative formula recommended by some workers consists of Rose Bengal 15½ grains in 35 oz. of water, to which is added 3 drs. of the strongest liquor ammonia (880). Of course, it must be understood that all the operations up to and including drying must take place in the dark. A little light is allowable when commencing, so as to ensure the plate being properly covered; but afterwards it is better to work in total darkness, or at any rate to see that no light reaches the plate. This may be done by boxing in the plate, afterwards placing it to stand in the lower half of the plate box covered with the lid.

INCREASING SENSITIVENESS TO CERTAIN COLOURS.

To add to the sensitiveness of the red as well as the yellow-green the plate should first of all be treated with the erythrosine

solution described above, and then, after slight rinsing, immersed for two minutes in a solution consisting of cyanine 1½ grs., alcohol 3 drs., and water 30 oz.

OTHER DYES USED FOR SENSITISING.

The compounds already referred to are those in general use, but many others have been employed successfully, including naphthofluoresceine, chrysaniline, benzoflavin, acridine yellow, acridine orange, diazo black, wool black, benzonitrol brown, quinoline red, chlorophyll, and eosin, and useful experimental work may be done with each. Considerable modification in some of the formulæ seems to be possible without appreciable difference in the result. The dye may in each case be added to the emulsion, but in experimental work the more usual plan will, of course, be to bathe the plate in a solution of the dye. The following formulae are given as likely to be of use:—

SENSITISERS FOR BLUE-GREEN AND GREEN.

Chrysaniline (sat. sol. in hot alcohol)... 10 minims.
Distilled water 1 oz.

Immerse plate from two to three minutes. Greater sensitiveness, but unfortunately accompanied by staining of the film, which can only be removed by alcohol, is given by

Acridine yellow (sat. sol. in hot alcohol) 200 minims.
Distilled water 1 oz.

SENSITISERS FOR GREENISH-YELLOW AND YELLOW.

First bathe the plate for two minutes in

Ammonia 10 minims.
Distilled water 1 oz.

Then immerse for a similar time in

Naphthofluoresceine (1 in 500) ... 60 minims.
Ammonia 10 ..
Distilled water 1 oz.

SENSITISERS FOR ORANGE AND RED.

First bathe the plate in 1 per cent. ammonia solution for about two minutes, then immerse in

Cyanine (1 in 1,000 alcohol) ...	1 oz.
Distilled water	10 oz.
Alcohol (90%)	$\frac{1}{2}$ oz.
Ammonia (10%)	2 oz.

Dry in the dark; before use bathe in distilled water for two or three minutes and expose while wet. A higher degree of sensitiveness to the red rays is given by diazo black, benzonitrol brown, and wool black.

THE SCREEN OR LIGHT FILTER.

Screens suitable for experimental work may be made very easily. Ordinary gelatine dry plates may have the silver salts cleared out, and the plate after washing immersed in the dye; thin microscopic glass may be dipped in collodion, and afterwards immersed in a suitable dye; or plates may be coated with gelatine or collodion, dried, and the films stripped off. As the last method is the most satisfactory in use it will be described in preference to the others, although slightly more troublesome. Take a sheet of patent glass, which should be close-ground and flat upon one side, the flattened side being readily detected. Rub this over with a waxing solution made by dissolving a little beeswax in turpentine, using sufficient of the latter to make a thin, easily managed medium, which may be applied readily with a small piece of flannel. The operation is the same as if preparing it to receive a double transfer carbon print. Now coat it with 10 per cent. solution of gelatine, as if varnishing a negative. Care must be taken that the gelatine is properly in solution, and able to run easily. The measure and the glass must both be warmed before coating. When firmly set immerse the glass in a solution of aurantia until the desired effect is obtained. Allow to dry thoroughly, cut round the edges, and strip off the glass. Collodion may be used instead of gelatine, in the same manner. Some workers prefer to add the dye to the gelatine solution or collodion before applying to the glass. Such a screen should be a pale lemon yellow, and of sufficient depth to increase the exposure by three times. It will be suitable

for use in ordinary landscape work when necessary, where all that is required is to cut out the ultra-violet and slightly tone down the blue.

MATCHING THE SCREEN TO THE PLATE.

It is often necessary to bring into play both the influences previously referred to, namely, to use not only the specially sensitive plate, but a suitable screen also. The Bausch and Lomb Ray Filter (Fig. 595) is a very convenient arrangement for securing a colour screen of any desired tint or depth. It consists of two thin pieces of optically worked glass between which is cemented a glass ring, thus

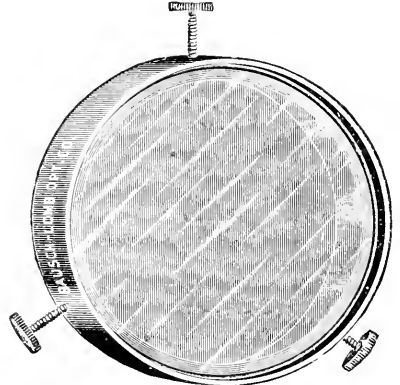

Fig. 595.—BAUSCH AND LOMB RAY FILTER.

forming a cell into which any suitable solution may be introduced through a small opening by means of a pipette. The glass portion is mounted in a metal ring with screws for attaching to the lens. Generally speaking, a very pale screen is sufficient, and it is safer always to employ one of this character. It must be understood, however, that the depth of the screen is dependent upon (a) the character of the subject, or its combination of colours, and (b) the special sensitiveness of the plate. It will be necessary, therefore, to make a few experiments with a view to finding the exact depth of tint required to produce a certain effect with a certain plate.

MAKING A GRADUATED SCREEN.

Take an ordinary dry plate, immerse it in a 1 per cent. solution of potassium bichromate, and dry it in the dark in a good current of air. (The same precautions must be taken in drying as are necessary in the carbon process.) When the plate is dry it should be exposed beneath a graduated scale of densities prepared as described on page 97: about five or six densities on the plate will be sufficient, and the width of each section should be about three-quarters of an inch. A half-plate cut through lengthways will provide a suitable shape and size. This bichromated plate is exposed with the glass side against the graduated deposit for a suitable length of time to be ascertained

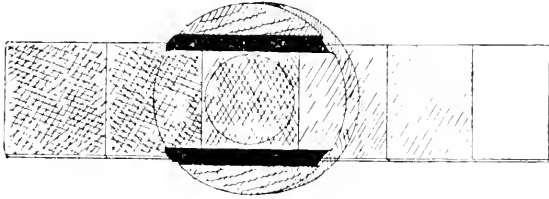

Fig. 595.—CAP ATTACHMENT FOR FILTER EXPERIMENTS.

by the actinometer. The plate is then washed in hot water to dissolve away the gelatine to the extent to which it may be soluble in the different portions. When this preparation is complete, the plate, on being held up to the light, will show various thicknesses of film which may be detected by the varying densities of the white deposits still left in it. The plate may now be immersed in a clean solution of hypo. and carefully washed; it is then bathed in a solution of aurantia until the thinnest deposit but one just shows a perceptible yellow tinge. A scale of colour deposits roughly prepared in this way will do much towards making clear the influence which the depth of the screen has upon the rendering of contrast in the result.

EXPERIMENTS WITH GRADUATED SCREEN.

To use the graduated screen, proceed as follows: Focus the image of the subject

as small as possible, then cut some quarter-plates with a diamond to a convenient size and place one in a quarter-plate carrier with a piece of cardboard on either side to hold it in position. Now, by means of a cap made as in Fig. 596, the graduated colour screen is arranged so as to pass in front of the diaphragm of a single lens. An exposure is first of all made of correct length in the ordinary way; next an exposure is given with the lightest tint in front of the lens, allowing a sufficiently increased time, as far as may be judged, substituting, of course, a fresh piece of plate. Another section is pushed forward, a third piece inserted in the slide and a third exposure made, and so on until all the tints have been used. Each plate must be carefully

marked with a number, showing the tint through which it was taken, on its removal from the slide. The plates are then all developed together for the same proportionate time, and a comparison of the prints from them will explain more than can be done in any ordinary way. There will probably be a marked difference between the plate used without the screen and that used with the two palest tints. If the screen is very deep, a blue object may be rendered almost black. Such an exaggeration is, of course, to be avoided, all that is required being to tone down the blue very slightly.

CHOICE OF LIGHT FILTER.

It is impossible to lay down hard and fast rules such as "when photographing such a subject use such and such a filter." The choice of the latter must be left to the discretion of the photographer, and will depend upon all the conditions. The

operator must, however, be acquainted with a few definite facts. All objects reflect a certain amount of white light irrespective of their colour, and if it were not for this, photography under present conditions would hardly be possible. This seems to the uninitiated a little difficult to believe, yet it may be proved to anyone's satisfaction who will take the trouble to examine through the spectroscope the light which is being reflected from any coloured surface, when it will be found that all the spectrum colours are shown, rays reflected from red, blue, or yellow varying apparently little in constitution. It is only when the illumination is cut down very greatly that the colour of the reflecting surface begins to assert itself.

PROPORTIONATE RENDERING OF CONTRAST.

The foregoing experiment will show that the contrasts obtained with the same plate and filter may be totally different when the exposure is unduly prolonged. Among the purposes for which the screen may be used, first and foremost comes that of toning down or reducing the activity of the violet and blue, and of eliminating entirely the ultra violet rays. These latter, as has already been shown, are exceedingly actinic, whilst being invisible to the eye; and the deposits produced by their aid must, under ordinary circumstances, lead to a false impression. In each case, however, the aim and object should be to render the *proportionate values* rather than the actual colour intensities. Photography can only register differences of intensity or luminosity, and when two different colours are of the same luminosity, they should photograph (upon a plate correctly orthochromatised and properly screened) exactly alike. The fact that the rays producing the different colour sensations are of different wave length, and may possibly produce a varying physical effect, need not be taken into account. The novice is apt to look upon certain colours as bright under all conditions, yellow being said to come out dark and blue light. Still, practical experience proves that such is not always

the case, for it is possible so to shade a blue that it photographs considerably darker than a yellow which is receiving more light. In the same way a screen which reduces the actinism of the blue may be made so deep as to practically obliterate it, the result being that the blue is rendered as black. This will mean, under ordinary circumstances, that the subject is falsely rendered as regards its proportionate values or contrast, but it is a great power in the hands of the photographer who is capable of using it discriminately.

THE SCREEN AS AN AID TO BRILLIANCY.

Thus the screen may be used to obtain brilliancy quite apart from a consideration of colour values, as, for example, when photographing mountain scenery, distant views, or in a veiled atmosphere. The shadow light under such circumstances consists largely of blue rays, which the screen is able to reduce, and thus enable the yellower high lights to impress themselves on the plate. Probably nothing will make this so clear as a practical experiment. Let two plates, which should preferably be orthochromatic, be exposed upon a distant view, or one slightly obscured by mist. The first should be exposed in the ordinary way without a screen, and for a correct length of time, and the other simultaneously under precisely the same conditions, except that it should be exposed through a fairly deep yellow screen, and for a proportionately increased time. Of course, it is understood that the subject should be the same in each case. The greater brilliancy of the latter negative will, if the experiment is properly carried out, be very apparent. It must, however, be understood that this procedure is not always advisable. It is, indeed, a power which is very liable to be abused. From an artistic point of view a slight indistinctness of distant objects is essential, in order to secure that atmospheric perspective which is, or should be, one of the chief charms of photographic views. By over-correcting with the screen, distant mountains may be rendered with a harsh distinctness which is exceedingly

PRINT FROM RED BLOCK ONLY.



PRINT COMBINING YELLOW AND BLUE.

unsatisfactory, and dwarfs them into mole hills. A fact which should not be lost sight of is that, when photographing in a yellow light, a screen is usually unnecessary, and may even be harmful. It will be seen that there are certain aesthetic considerations to be taken into account besides those of scientific interest. So that, in order to come to a definite conclusion as to the choice of plates and screens, it will be necessary to consider them in connection with the special work for which they are to be employed.

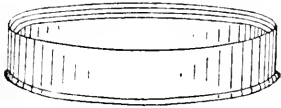

Fig. 597.—LIGHT FILTER TO SCREW BEHIND LENS.

POSITION OF THE LIGHT FILTER.

Considerable controversy has taken place upon the best position for the light filter, and a few words on this subject may prove of service. When the coloured glass forming the screen is optically worked, that is, made perfectly flat upon both sides, its position, from a practical point of view, is unimportant; although it must not be forgotten that the nearer the screen is to the plate the less light is lost. This applies with almost equal force when a filter is used which is extremely thin, such as a dyed sheet of collodion or gelatine. Such filters, however, especially when home made, are often a little cloudy, and apt to interfere with proper definition, therefore the nearer they are to the plate the better. Again, it should be understood that the unevenness of the surface is more apparent the smaller the bundle of rays which has to pass through it. So that if the filter is placed in the diaphragm opening, where the bundle of rays is very small, the unevenness is most harmful, whilst as it is removed from this towards the plate, any defect becomes less noticeable. Optically worked filters are usually fitted in a rim and made to screw behind the lens as in Fig. 597, but home-made filters should be fixed either in contact with the plate or

immediately before it. In small size cameras the filter may be slipped into the dark slide and focussing done through it on a piece of ground glass placed in the slide. This answers well enough for occasional exposures, but for general use the method shown in Fig. 598 is far preferable.

ORTHOCHROMATIC PLATES IN LANDSCAPE WORK.

Valuable as is the use of orthochromatic plates, a great deal too much emphasis is at times laid upon the necessity for employing them, while claims are made

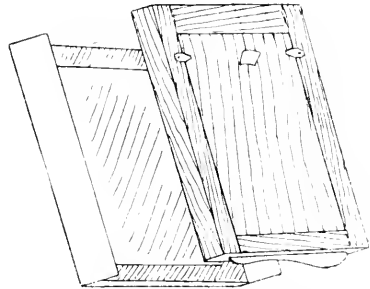

Fig. 598.—METHOD OF FIXING SCREEN IN FRONT OF DARK SLIDE.

which could never be substantiated. Some workers pride themselves upon using these plates for every description of work, but it will hardly be necessary to point out to the practical photographer the disadvantages of such a practice. The orthochromatic plate is in the nature of a special appliance, and should be reserved for special use. The inferior latitude permissible in the exposure, development, and gradation of the plates, and the increased precautions necessary in their manipulation, render them unsuitable for general use, important as they are in their particular sphere. For example, a large number of landscapes that are brilliantly lighted will photograph equally well upon an ordinary dry plate, and there will be scarcely any advantage in the use of orthochromatic plates. Most exposures made near the middle of the day upon ordinary subjects, such as are attempted by the general run of hand

camera workers, will come under this heading. It is when the preservation of contrast in certain coloured portions of the subject is essential that the use of orthochromatic plates is imperative. Also, bearing in mind that these plates possess a superior sensitiveness to rays of certain colours, when photographing in light of that colour they will be of assistance in shortening the exposure. To secure cloud negatives, the plates are often extremely useful when used in conjunction with a screen. In ordinary landscape work the use of a screen or light filter will aid in bringing out the clouds in the sky, but they can generally be more successfully added afterwards, and are usually obtainable only at the expense of the gradations in the foreground.

FLOWER STUDIES, ETC.

From their generally close proximity to the lens such objects do not reflect much surface light, and therefore orthochromatic plates and a light filter become necessary. A group of chrysanthemums, for example, would give a remarkably false effect when photographed upon an ordinary plate. A plate sensitised for the yellow rays will usually suffice with a very pale yellow screen. Unless blues are present, however, the screen is, as a rule, unnecessary. Due attention must be paid in this regard to the background, which should usually be a middle tint. It is interesting to compare the examples given in the Plate of two photographs of the same subject taken with and without a screen.

ORTHOCHROMATIC PLATES IN PORTRAITURE.

The use of orthochromatic plates for portraiture is by no means general, nor are they necessary for the usual run of work. Their employment in certain cases, however, is to be recommended, as, for example, in photographing fancy costumes containing combinations of colour whose proportionate contrast might otherwise be altered. Where also the costume consists entirely of red, a plate prepared with cyanine will prove an advantage in rendering more shadow detail.

It is seldom, however, that the use of a screen is necessary, as few of the ultra-violet rays are present in the studio, being generally abstracted from the light before it reaches the lens. The use of yellow blinds is invariably sufficient for the purpose of reducing the blue rays. The use of such blinds is also effective in rendering freckles less apparent, even when using ordinary plates, but the considerable increase in exposure tends to counteract any real benefits that might arise. When, therefore, this end is in view the orthochromatic plate by its superior sensitiveness will be of great service. The freckles will be much less apparent on an orthochromatic plate even when no yellow blinds are used. When a studio is fitted with ordinary blinds the effect may be easily arranged for by throwing a length of yellow muslin over the head screen, and in this way the screening effect may be localised or confined to the face. Again, when photographing sitters with golden or auburn hair, orthochromatic plates will give a far more correct rendering. It will be seen, therefore, that, although these plates are not recommended for general use, yet a knowledge of their manipulation is at times essential. The fact that so many photographers still indulge in rule of thumb development, judging the density by continual viewing against the light, has no doubt much to do with the unpopularity of such plates; since, worked in this way, they are sure to produce more fog than is even allowable in portraiture. Developed, however, with a light which passes a minimum of actinic rays, and by the time system, there should be no trouble.

COPYING PAINTINGS.

The fact cannot be emphasised too strongly that photography is incapable of rendering colour contrasts, for if this point is overlooked it may lead the photographer very seriously astray. It may often happen in copying paintings that parts which are quite dissimilar, by reason of their difference of colour, photograph alike, even when an orthochromatic plate is used. Such parts may be detected by

viewing the original through a coloured screen before photographing. It may even happen that a better effect is secured upon an ordinary plate, when merely a difference is required to be shown between the two portions regardless of their values. Many water colours, by reason of the amount of white light which they reflect, can be photographed very successfully on ordinary plates; but, for general work, orthochromatic plates and screens are imperative. Instead of using screens, however, it is customary in ordinary work to illuminate the object with yellow light. As these paintings are usually copied by artificial light so that its effect may be more easily controlled, this becomes simply a matter of placing suitable glasses in front of the light. The disadvantage of this method consists in the limitations of screening. Ordinary water colours of well-lit subjects require merely illuminating with a pale yellow light to give a perfectly correct rendering. When, however, the painting is heavy and deep in tone, the screen needs to be deeper and the exposure proportionately prolonged. Such pictures usually contain a good deal of red, and plates prepared with cyanine, or otherwise made specially sensitive to these rays, should be employed. Where the picture is very dark and wanting in contrast, a very deep screen and an extremely long exposure will often bring it up considerably. It is in such work that liquid filters will be of especial use, as with them the density of the filter can be controlled to a nicety. The objection usually raised to such filters, on account of their alleged messiness and inconvenience, is of much less consequence under these circumstances.

ADJUSTING THE DARK-ROOM LIGHT.

Since orthochromatic plates allow less latitude than the ordinary variety, it is more essential that they should be correctly exposed. This is not always an easy matter for the beginner owing to the screening, but the difficulty soon disappears with experience. As before stated, the plates show much more tendency to fog either by light or develop-

ment. The greatest care should be taken over the choice of glass for the ruby lamp when such plates are to be used, the usual glass supplied with these lamps being anything but safe. As a matter of fact, there is no really safe light, as all glasses pass a certain amount of actinic rays. The best plan is to obtain several samples and examine them through the spectroscope. The one passing a maximum of light with a minimum of actinic rays will, of course, be best. It simplifies matters if the samples under comparison are of about the same density. They may be compared visually or photographically, the latter for preference. The method of conducting this examination is described in the section on Spectrophotography. For a rough test the glasses may be placed half way over the slit, when the spectrum formed may be compared with that from the unobstructed half.

SIMPLE TESTS FOR SAFETY OF LIGHT.

Those who do not care to go to this trouble may experiment by leaving a plate exposed to the rays of the lamp with one half covered. The plate may be so exposed for one minute, and should show no difference between the two halves in the developer. Or samples of different glasses may be fitted in a frame and a plate exposed behind them after the manner of the artificial spectrum previously described. As a general rule a ruby glass must be used, but for plates which have been sensitised for red, a green glass should be employed. If there is any difficulty in obtaining these, a pair of dry plates from which the silver salt has been fixed, and washed out, may be immersed in dye and the two bound up together, film inwards. For the red, the plate may be immersed in a 1 per cent. solution of erythrosine; while for the green, a mixture of methyl blue and auramine may be employed. When plates are made sensitive to both green and red a glass composed of a deep orange and violet combined may sometimes be used. The plate may only be exposed for a minimum of time, even to the light least active.

DEVELOPMENT OF ORTHOCHROMATIC PLATES.

Care must be taken not to over-develop these plates, and thus bury the high lights in an endeavour to abstract every portion of detail from the shadows. This is a common fault among beginners. Where the negative is to receive proper attention afterwards this is, perhaps, not of so much consequence, since, by getting out all the details in the shadows, afterwards covering the back of the negative with *papier mineral*, and cutting it away from the dense portions, results obtainable in no other way may sometimes be secured. For it should be borne in mind that the orthochromatic effect becomes stronger and more apparent as development is prolonged. When to stop development is, however, most accurately decided by the time system, based upon actual experiment. Of the developer little need be said, beyond the fact that pyro-ammonia is unsuitable for these plates. Practically all the other developers may be employed, but pyro-soda seems to have obtained a deserved preference. As there is a decided tendency to fog if developed without the use of a restrainer, it is never advisable to omit it.

KEEPING QUALITIES OF ORTHOCHROMATIC PLATES.

The keeping qualities of orthochromatic plates under the most favourable conditions are not greatly inferior to those of any other highly sensitive plates, all of which are, of course, very liable to be affected by outside influences. The emulsion appears to be in such a condition that when stored in impure air the plates deteriorate very rapidly. Sea air appears to be especially harmful. If, however, the plates are always kept stored in a cool dry place, wrapped in waxed paper, and the box enclosed in a rubber bag, they will usually keep well. In any case the orthochromatic effect appears to be gradually lessened with long keeping, and fog induced. Plates should on no account be left loose in boxes or dark slides where the air may have easy access.

COMMERCIALLY PREPARED PLATES.

Although there are many points in favour of home-prepared orthochromatic plates, for those who possess the necessary skill, experience, and convenience, yet, on the whole, workers will be well advised to employ one of the excellent brands now on the market. The "Spectrum" plate issued by Messrs. Cadett and Neall, used in conjunction with their special light filters, and carefully worked in a proper light, gives as accurate results as can be hoped for, in view of the fact already stated, that no plate can give an absolutely perfect rendering of colour values. They are especially valuable in three-colour work and in copying paintings. In using either these or any of the other excellent makes now on the market it must not be forgotten that success depends largely upon the judgment exercised in screening. It is useless to expect accurate results from all sorts of subjects with the same screen. Theoretically every combination of colour demands a separate screen, but in practice two or three are usually found sufficient.

THE CHAPMAN JONES PLATE TESTER.

A convenient means of testing the colour rendering and other properties of a sensitive plate, or for ascertaining the effect of various colour screens, is afforded by the plate tester devised by Mr. Chapman Jones in 1900. This consists of a number of graduated squares by which the sensitiveness and range of gradation of the plate examined may be determined; a series of squares of different colours and mixtures of colours of equal visual intensity, which will indicate the colour sensitiveness; and a strip of uncoloured space for comparison purposes. It is simply necessary to expose the plate being tested, in contact with the screen, to the light of a standard candle. A suitable frame and stand are supplied for the purpose; any other light may, however, be used if desired. The plate is then developed, when an examination of the negative will yield the desired information. The idea of the coloured squares is

based on that of the Abney Colour Sensitometer, where three or four squares of coloured and one of uncoloured glass are brought to an equal visual intensity by backing where necessary with squares of exposed celluloid film developed to suitable density. This arrangement is on the same principle as the artificial spectrum described on p. 443.

CONCLUDING REMARKS.

Undoubtedly the best means of obtaining a proper knowledge of orthochromatic photography is to experiment along the lines indicated, but the fact must never be lost sight of that experiments with the spectrum do not form an exact guide for

general work. In photographing natural objects in daylight the photographer seldom or never has pure spectrum colours to deal with, but colours mixed with white light. So that, after obtaining some knowledge in this way, it is well to make actual exposures on ordinary subjects through various screens, and keep full notes of the results obtained. It is surprising that orthochromatic plates are still, comparatively speaking, so little used by the average photographer. This is largely due to an altogether erroneous idea that they are difficult to work. Any one who has once tried them on subjects possessing colour, using them in a careful and scientific manner, will hardly wish to return to the ordinary variety.

CHEMISTRY OF CARBON COMPOUNDS USED IN PHOTOGRAPHY.

INTRODUCTION.

PERHAPS the most important compounds used in photography are the so-called "organic" developers, such as pyrogallol, amidol, eikonogen, etc. Before discussing these substances it would be as well to have some idea of the meaning of the term "organic." In the early days of chemistry two classes of chemical compounds were recognised, those obtained from mineral substances and those of animal or vegetable origin. It was held, at that time, that substances of the latter character could not be obtained artificially. Hence the science of chemistry was divided into two distinct branches, dealing respectively with compounds requiring for their production, some vital process, which were called organic compounds, and those not requiring any living organism for their formation, and consequently designated inorganic compounds.

REVISION OF EARLY THEORIES.

In 1826, however, Hennell obtained ethyl alcohol artificially, and in 1828 Wöhler synthesised an essentially organic substance, urea. Neither of these investigators utilised the living organism for the production of those compounds. These discoveries mark a very important stage in the development of chemistry, especially that of Wöhler, as they gave the deathblow to the theory that to obtain organic compounds some form of life was necessary. Since 1826 a very large number of these so-called organic compounds have been obtained by artificial means, and the same laws have been found to govern organic compounds as those governing inorganic substances. The

terms "organic" and "inorganic" are, however, still retained, simply for the sake of convenience. All organic compounds contain the element carbon, consequently organic chemistry is often defined as the chemistry of the carbon compounds. When it is considered that these number, at the present time, from about seventy to eighty thousand different substances it will readily be understood that they are best studied separately. An attempt will therefore be made to convey to the photographer, in as simple language as possible, a few points in connection with the chemistry of some of the organic compounds used in his work.

CLASSIFICATION OF CARBON COMPOUNDS.

As the result of a detailed study of organic compounds, they are found to fall naturally into two groups. One division contains those whose properties and reactions can only be explained by assuming that the carbon atoms in the molecule are arranged in the following manner:—

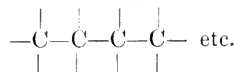

As some of the most important members of this group were found in various fats and oils, they were termed "fatty compounds." A better way of referring to them, however, is to call them "open chain" compounds, owing to the manner in which their carbon atoms are arranged in the molecule. The second group behave in a different way towards chemical reagents, and this difference of behaviour can only be accounted for on the assumption that the carbon atoms in the molecule are arranged in the form of a closed ring, or cycle, as below:

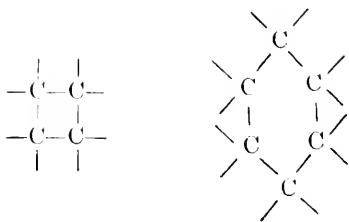

Hence they are termed "closed chain" or cyclic bodies. They are also known by the name of "aromatic" compounds, because at one time their most characteristic substances were obtained from the various aromatic gums and balsams.

MOLECULAR AND CONSTITUTIONAL FORMULÆ.

By making a qualitative examination of the organic compounds their component elements are ascertained, and those usually present are found to be carbon, hydrogen, oxygen, nitrogen, and sulphur. If the compound is submitted to a quantitative analysis, the percentage of each element is obtained; and if its physical properties in the state of vapour are examined, the chemist is then in a position to state the number of atoms of each element present in the molecule. [For a detailed explanation of these processes the photographer is referred to any text-book on organic chemistry.] By writing the symbols of these elements, together with their proper exponents, the molecular formula is obtained. Thus: Ethyl alcohol contains the elements carbon, hydrogen, and oxygen. From a quantitative and physical examination of the substance it is found to contain in the molecule two atoms of carbon, six atoms of hydrogen, and one atom of oxygen; its molecular formula is, therefore, C_2H_6O .

ISOMERISM.

Now it so happens that a large number of organic compounds have the *same* molecular formulæ, but have different chemical and physical properties. This peculiarity is termed isomerism, and the compounds are said to be isomeric. Thus the formula $C_6H_6O_2$ represents three important compounds, pyrocatechol, resorcinol, and hydroquinone. The formula C_2H_6O represents ethyl alcohol and methyl ether. By making a careful study of the re-

actions and transpositions of isomeric substances they are found to differ in chemical deportment, which leads to the assumption that their molecules are differently arranged, or constituted. A formula which shows this arrangement of the atoms in the molecule is termed a constitutional formula, and a knowledge of the latter is obviously highly important in dealing with organic compounds.

METHOD OF DEDUCING CONSTITUTIONAL FORMULÆ.

In order to illustrate the kind of reasoning employed, the constitutional formulæ of ethyl alcohol and methyl ether are here deduced. Both these compounds have the molecular formula, C_2H_6O , and are, therefore, isomeric. Ethyl alcohol is a liquid, and methyl ether a gas, at ordinary temperatures. In determining the constitutional formula, the combining power or valency of each element must be taken into account. Of the three elements present in the two compounds mentioned, carbon is tetravalent, hydrogen monovalent, and oxygen divalent. Writing out the atoms of each element and connecting them by means of small lines or bonds, to represent the valency, two formulæ are obtainable.

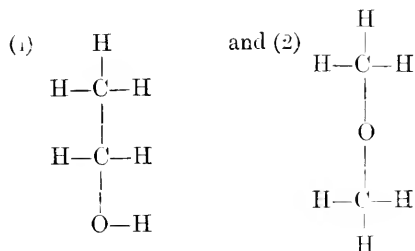

IDENTIFICATION BY PRESENCE OR ABSENCE OF HYDROXYL.

No other arrangement is possible keeping the valencies mentioned. Which formula, therefore, represents ethyl alcohol, and which the methyl ether? If both compounds are treated with metallic sodium it is found to react only with the alcohol, hydrogen being evolved, and its place taken by sodium. Now in nearly all cases sodium reacts in this manner with all compounds containing the group $-\text{OH}$, hydroxyl. A compound known as phosphorus

penta-chloride is a very good reagent for ascertaining the presence of hydroxyl. It has been found that if a compound contains $-\text{OH}$, this group is replaced by one chlorine atom when treated with the phosphorus penta-chloride. If it is allowed to act upon ethyl alcohol it produces a substance which on analysis is found to have the formula $\text{C}_2\text{H}_5\text{Cl}$. If this new body is compared with ethyl alcohol $\text{C}_2\text{H}_5\text{O}$, it will readily be seen that $-\text{OH}$ has been replaced by one atom of chlorine. Consequently this reaction, and that of the sodium, shows that the alcohol contains a hydroxyl group. If the methyl ether is treated with phosphorus penta-chloride a far deeper change takes place, and the molecule is completely broken down. On inspecting the two constitutional formulæ previously deduced it will be seen that only No. 1 contains a hydroxyl group. Consequently this must be the constitutional formula for the alcohol, and the other formula, No. 2, that of the methyl ether. These two formulæ are completely in harmony with the chemical properties of the two substances. Instead of writing out the constitutional formula fully it is slightly contracted. Thus:—

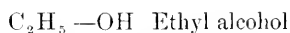

All constitutional formulæ have been worked out on the lines mentioned above, by similar careful experiment and reasoning.

RADICALS.

Mention has already been made of compound radicals, and as these are of very frequent occurrence in organic chemistry, a few of them are dealt with here. The number of bonds represents the valency of the group as a whole.

It will be seen that the various alkyl radicals are the analogues of the metals of the alkali group, sodium, potassium, etc. Methyl chloride, for example, is analogous with sodium or potassium chloride. Because of this analogy they were termed *alkyl* groups. In the following table a few of the more commonly occurring groups are brought together.

Compound Radical.	Name.
$-\text{CH}_3$	Methyl group
$-\text{C}_2\text{H}_5$	Ethyl ..
$-\text{C}_3\text{H}_7$	Propyl ..
$-\text{C}_4\text{H}_9$	Butyl ..
$=\text{CO}$	Ketonic group
$\begin{array}{c} \diagup \text{O} \\ \text{C} \\ \diagdown \text{H} \end{array}$	Aldehydic group
$-\text{OH}$	Hydroxyl or phenolic group
$-\text{NH}_2$	Amido or amino group
$=\text{NH}$	Imido group
$\begin{array}{c} \diagup \text{OH} \\ \text{C} \\ \diagdown \text{O} \end{array}$	Carboxylic group
$-\text{HSO}_3$	Sulphonic acid group
$-\text{NO}_2$	Nitro group
$-\text{NO}$	Nitroso group

GROUPING OF ORGANIC COMPOUNDS.

Organic compounds are grouped into various families according to their constitution. Some of the more important groups, together with their general formulæ, are given below. R stands for alkyl radical (see first table).

General Formula.	Name of Family or Group.
$\text{R} + \text{H} \quad \text{or} \quad \text{RH}$	Hydrocarbons.
$\text{R} + \text{OH} \quad \text{..} \quad \text{ROH}$	Alcohols.
$\text{R} + \text{NH}_2 \quad \text{..} \quad \text{RNH}_2$	Amines.
$\text{R}_2 + \text{CO} \quad \text{..} \quad \text{R}_2\text{CO}$	Ketones.
$\text{R}_2 + \text{CHO} \quad \text{..} \quad \text{RCHO}$	Aldehydes.
$\text{R}_2 + \text{O} \quad \text{..} \quad \text{R}_2\text{O}$	Ethers.
$\text{R} + \text{COOH} \quad \text{..} \quad \text{RCOOH}$	Acids.
$\text{R} + \text{NO}_2 \quad \text{..} \quad \text{RNO}_2$	Nitro compounds.
$\text{R} + \text{Cl} \quad \text{..} \quad \text{RCl}$	Haloid compounds.

EXAMPLES OF THE FOREGOING.

The following are a few common examples of some of the above families:

CH_3OH	Methyl alcohol.
$\text{C}_2\text{H}_5\text{OH}$	Ethyl alcohol.
$(\text{CH}_3)_2\text{CO}$	Acetone.
CH_3COOH	Acetic acid.
$(\text{C}_2\text{H}_5)_2\text{O}$	Ethyl ether or ordinary ether.
CH_3CHO	Acetaldehyde.
HCHO	Formaldehyde or formalin.

All these families may be derived from the hydrocarbons by replacing one or more hydrogen atoms by these various compound groups.

One important family of hydrocarbons is known as the "paraffins," and a few members are here given:

CH ₄ Methaneminus H	CH ₃ Methyl group.
C ₂ H ₆ Ethane	C ₂ H ₅ Ethyl "
C ₃ H ₈ Propane	C ₃ H ₇ Propyl "
C ₄ H ₁₀ Butane	C ₄ H ₉ Butyl "
C ₅ H ₁₂ Pentane	C ₅ H ₁₁ Amyl "

Replacement of one H atom by OH gives the alcohols.

CH ₄	CH ₃ OH	Methyl alcohol.
C ₂ H ₆	C ₂ H ₅ OH	Ethyl alcohol.
C ₃ H ₈	C ₃ H ₇ OH	Propyl alcohol.
C ₄ H ₁₀	C ₄ H ₉ OH	Butyl alcohol, etc.

The other series of families may be derived in a similar manner.

“ OPEN CHAIN ” COMPOUNDS.

It is now proposed to consider a few “ open chain ” compounds used in photographic work. With regard to the hydrocarbons, the only one, perhaps, that the photographer will have to deal with is acetylene, which is used for illuminating purposes. This hydrocarbon belongs to a series of compounds having the general formula C_nH_{2n-2}, where n is the number of carbon atoms. It is obtained by treating calcium carbide with water.

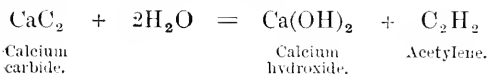

It will suffice to mention here that it is poisonous, and forms a highly explosive mixture with air.

THE ALCOHOL FAMILY.

Methyl alcohol, CH₃OH. This compound is used as a solvent for varnish making, etc. In the presence of an oxidising agent it undergoes oxidation, producing in the first place formaldehyde and then formic acid.

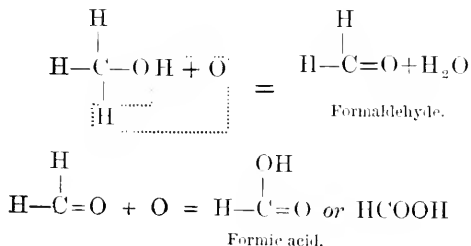

ETHYL ALCOHOL.



This is the next alcohol in the series and has a variety of uses in photography, principally as a solvent. When mixed with methyl alcohol (commercially known as wood spirit) it is termed methylated spirit. Submitted to oxidising agents it passes first to acetaldehyde, the next aldehyde to formaldehyde, and then to acetic acid, the next acid in the series to formic acid. The equations representing these changes are :—

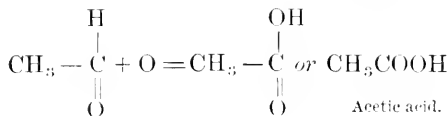
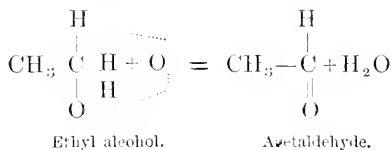

If ethyl alcohol is treated with strong sulphuric acid and then heated to about 147°C. a molecule of water is abstracted from two molecules of the alcohol, and ether produced. The equation may be written :—

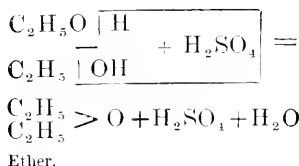

ALDEHYDE FAMILY.

Formaldehyde, or formalin HCHO. Formaldehyde is obtained by oxidising methyl alcohol, as already mentioned. It is used in photography for hardening the gelatine films, so as to prevent frilling in hot weather, and also as a preservative of mountants, as it destroys bacteria. At ordinary temperature the formaldehyde is a gas, and it is usually met with in practice as a 40 per cent. solution under the name of formalin.

POLYMERISM.

After standing, the formalin undergoes a very remarkable change, producing a variety of

compounds which, on analysis, are found to be multiples of HCHO.



Compounds which condense with themselves to produce new compounds, as in the case of formaldehyde, are said to undergo *polymerisation*, and the new compounds formed are termed polymers of the original substance. If exposed to the air it undergoes oxidation, producing formic acid.

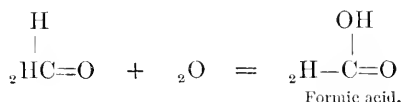

Owing to this fact, formaldehyde and the aldehydes as a class are powerful reducing agents. This reducing action is readily seen by adding formalin to an ammoniacal solution of silver nitrate. After a short time silver separates on the sides of the vessel as a brilliant mirror.

ACETALDEHYDE, CH₃CHO.

This is the aldehyde of acetic acid, and may be obtained by adding an oxidising agent to ethyl alcohol.

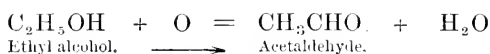

The aldehyde combines directly with prussic acid, HCN, and the alkaline bisulphites; with HCN they produce compounds termed *cyanhydrins*.

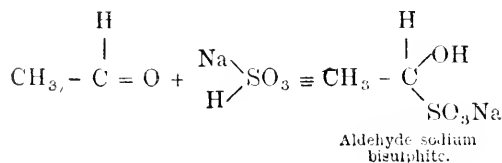
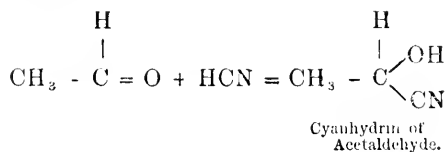

FAMILY OF ORGANIC ACIDS.

The organic acids form a very large group of compounds, and for purposes of study they are divided into various sub-groups, according to the radicals present. For instance, acids containing one carboxyl group are termed monocarboxylic acids, those containing two are called dicarboxylic acids, and so on. If the acid contains hydroxyl groups as well, they are said to be hydroxy-carboxylic acids, mono, di, or tri, etc., as the case may be. The most common organic acids used in photography are probably acetic, oxalic, and citric acids, together with their salts.

MONO-CARBOXYLIC ACID FAMILY.

Acetic acid, CH₃COOH. This is a very common acid, and in a dilute solution, together with colouring matter, it constitutes vinegar. Ordinary brown vinegar is obtained by allowing sour beer, etc., to undergo bacterial oxidation. If spirits or white wines are used in place of the beer, white vinegar is obtained. As is well known, beer and spirits contain ethyl alcohol, and when this compound undergoes oxidation it produces acetic acid. It is due to this acid that vinegar has a sharp taste.

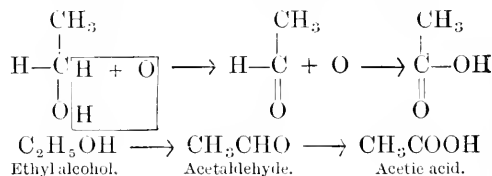

The pure, concentrated acetic acid is known under the name of glacial acetic acid, it being this variety that is principally used in photography.

PREPARATION OF GLACIAL ACETIC ACID FROM VINEGAR.

A quart or so of vinegar is placed in a retort and distilled, until the distillate coming over is only very slightly acid. The distillate is then neutralised with sodium carbonate and evaporated to dryness on the water bath. The solid remaining is sodium acetate.

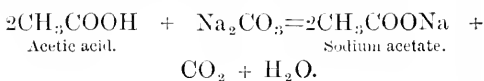

The sodium acetate is then introduced into a dry retort, just covered with a little concentrated sulphuric acid, and cautiously heated. The distillate is glacial acetic acid.

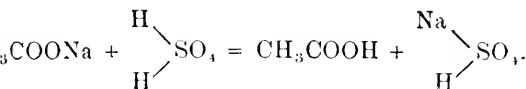

Acetic acid is used with ferrous sulphate in developing wet collodion plates. The acid acts as a restrainer, by preventing the too rapid deposition of silver, as will be explained more fully later on. It dissolves the silver, forming silver acetate.

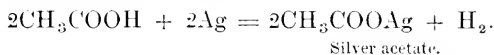

This acid is also employed in the lead and uranium intensifiers in order to keep these solutions weakly acid, and for washing bromide prints after development with ferrous oxalate, or toning with uranium salts. It should contain no furfural or formic acid, as these substances are harmful for photographic purposes.

TEST FOR FURFUROL.

This is a cyclic body containing oxygen, and causes complications by acting as a reducing agent. It may be detected in minute quantities by adding a drop of aniline to the suspected acetic acid. If present, a deep red colour is produced, disappearing on standing.

TEST FOR FORMIC ACID.

This acid acts as a powerful reducing agent. It is detected by adding a solution of silver nitrate. A brown precipitate of reduced silver shows that formic acid is present. In some cases acetic acid is adulterated with the mineral acids, hydrochloric and sulphuric acids. Their presence may be shown by using the reagents mentioned under nitric acid. These impurities may be removed by distilling the acetic acid from a retort to which a little potassium bisulphate and bichromate have been added.

These two compounds, the bisulphate and bichromate, are powerful oxidising agents, and completely oxidise the furfural and formic acid to carbon dioxide and water.

DI-CARBOXYLIC ACIDS.

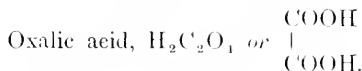

This acid is obtained by oxidising sawdust, by fusion with caustic potash. It is also obtained when many complex organic compounds, such as sugar, are heated with strong nitric acid. In photographic work the acid is employed in the form of its ferrous salt, in the well-known ferrous oxalate developer. Ferrous oxalate itself is insoluble in water, but is readily soluble in a solution of potassium oxalate, consequently the developer is so arranged that this potassio-ferrous oxalate is present. This condition is obtained by mixing a solution of ferrous sulphate with potassium oxalate, and is produced in accordance with the following equation :—

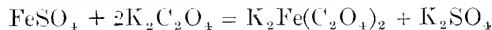

or

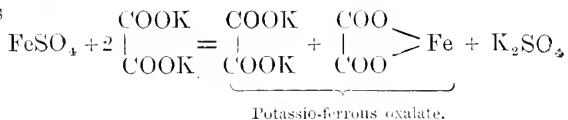

ACTION OF LIGHT ON FERRIC OXALATE.

It is interesting to notice that a ferric oxalate solution, which is the compound produced after the ferrous oxalate developer has done its work, is reconverted to the ferrous state by exposure to the action of sunlight.

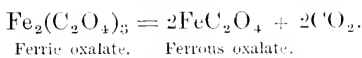

Because oxalic acid contains two carboxyl groups it therefore forms two classes of salts. Thus :



Oxalic acid and its salts are powerful reducing agents, and it is owing to this fact that they find employment in photography. If they are added to solutions of gold, silver or platinum, the metal is precipitated. Oxalic acid crystallises with two molecules of water.

HYDROXY-TRI-CARBOXYLIC ACIDS.

Citric acid, $\text{CH}_2(\text{COOH})-\text{CH}(\text{OH})\text{COOH}-\text{CH}_2\text{COOH}$.

This acid forms three classes of salts, because it contains three carboxyl groups. The three potassium salts are given below.

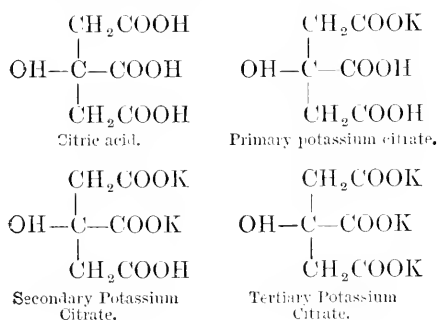

SENSITISERS.

Citric acid and the citrates, in the presence of the silver haloids, increase the photo decomposition of the latter, and make them more sensitive to the action of light. Hence they are often spoken of as sensitisers.

FAMILY OF THE KETONES.

Practically the only ketone used in photographic work is the di-methyl ketone, or, as it is usually termed, acetone. This compound is obtained technically from crude wood spirit or by the dry distillation of calcium acetate.

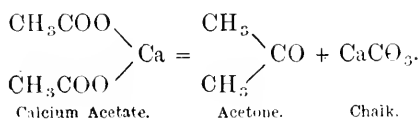

On the addition of sodium or potassium bi-sulphite to acetone a white crystalline compound is obtained known as acetone alkaline bi-sulphite. It is produced in accordance with the following equation :

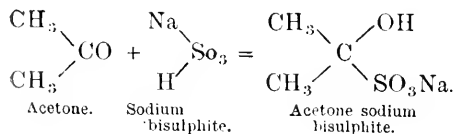

This compound is used in place of the metallic sulphite in photographic developers. It is extremely soluble in water, and acts as a powerful preservative. It has also been found that acetone in the presence of sulphite can be used in place of the alkaline carbonates in development.

AMIDO CARBOXYLIC ACIDS.

Glycin, or glycooll, $\text{NH}_2-\text{CH}_2-\text{COOH}$. This compound is acetic acid in which one hydrogen atom of the methyl group has been replaced by an amido group (NH_2).

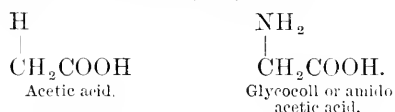

The photographic developer known by the name of "glycin" is glycooll in which one of the amidic hydrogen atoms has been replaced by the complex group $-\text{C}_6\text{H}_4(\text{OH})-$ present in carboic acid or phenol. This $\text{C}_6\text{H}_4(\text{OH})$ group is cyclic in structure, consequently the developer is both a cyclic and open chain compound. Its constitution is as follows :

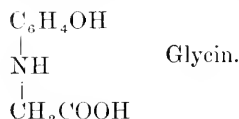

The cyclic part of the compound, the $\text{C}_6\text{H}_4\text{OH}$ group, and the carboxyl group are acid in character, consequently it readily combines with alkalies, forming various salts. It is slow in its action, producing a hard negative, and is useful in copying drawings, etc.

COMPLEX ORGANIC COMPOUNDS.

There are a large number of organic compounds of a very complex nature whose constitution, up to the present, has not been determined. It so happens that these bodies are indispensable in photography, and the art has been brought to a great state of perfection by their employment. Among them may be mentioned cellulose, albumen, and gelatine.

CELLULOSE
($\text{C}_{12}\text{H}_{20}\text{O}_{10}$)_x

This is the principal constituent of the cell membranes of all plants. It may be obtained

in a pure form by submitting wadding or plant fibre to the action of (1) dilute potash, (2) dilute hydrochloric acid, washing with water in each case. It is then treated with alcohol and ether. So obtained, it is a white amorphous mass. Swedish filter paper, which has been submitted to these reagents, consists almost entirely of pure cellulose. This substance is practically insoluble in all the usual solvents, but dissolves, without undergoing any change, in ammoniacal copper solutions. Acids re-precipitate it as a gelatinous mass. It is soluble in concentrated sulphuric acid, depositing a starch-like compound on the addition of water.

CELLULOSE NITRATES, OR "NITRO"
CELLULOSES.

It has already been noticed that by replacing the hydrogen in nitric acid by a metal the nitrates are obtained. Organic radicals or groups of radicals can also replace the hydrogen of nitric acid, forming an organic nitrate. Thus:—

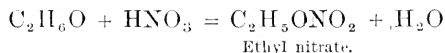

If cellulose is treated with nitric acid various nitrates are obtained.

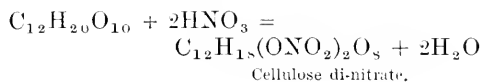
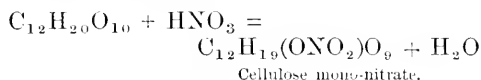

It will be noticed that water is produced in the reaction. To remove this, and thus prevent it from diluting the nitric acid, strong sulphuric acid is used. The resulting nitrates exhibit varying properties depending upon their method of formation.

GUN-COTTON, OR PYROXYLINE.

If, for example, pure cotton is immersed two or three times in a cold mixture of one part of nitric and three of sulphuric acid, and then washed with water, it is converted into cellulose hexa-nitrate, which is known as gun-cotton, or pyroxyline.

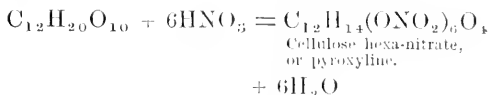

This hexa-nitrate is insoluble in alcohol and ether.

COLLODION.

If cotton is exposed to the action of a warm mixture of twenty parts of powdered potassium nitrate and thirty parts of concentrated sulphuric acid, a mixture of tetra and penta cellulose nitrates is obtained, which dissolves in ether containing a little alcohol. This is termed soluble pyroxyline, and the ether alcohol solution is termed collodion.

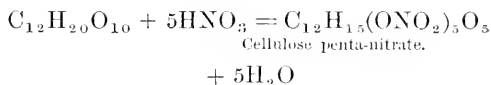
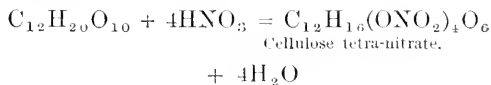

On allowing collodion to evaporate the pyroxyline is left as a uniform transparent film. To render it photographically sensitive, the collodion is treated with varying mixtures of some soluble iodide and bromide, usually the ammonium and cadmium compounds. The coated plate is then dipped in a solution of silver nitrate, by which means it is covered with a layer of silver bromide and iodide.

The equations representing the changes are:



Ammonium iodide. Silver nitrate. Silver iodide. Ammonium nitrate.



Cadmium bromide. Silver bromide. Cadmium nitrate.

The prepared plate is exposed whilst still wet with the silver nitrate solution, as this is the sensitiser. This is a very important point to be noticed, in connection with the wet collodion process, as the collodion by itself has no halogen absorbing power.

CELLULOID.

The mono, di, and tri nitro compounds of cellulose are dissolved in special solvents, such as acetone and camphor, thereby producing plastic masses known under the names of celluloid and xylonite, which can be moulded and cut into various forms.

ALBUMEN.

The molecular magnitude of albumen is unknown. According to Sabanejeff, the number 15,000 was obtained as the molecular weight of purified egg albumen. Stohmann and Langbein (*Journal für Praktische Chem.* [2] 44,345) have given albumen the molecular formula $C_{720} H_{1134} S_5 O_{248} N_{218}$. This may or not be the true formula, but it is sufficient to show that albumen contains a very large number of atoms in the molecule. For photographic use, purified egg albumen (or white of egg) is employed. This is soluble in water, but if heated to a temperature of about 70°C. becomes insoluble, or, as it is termed, coagulated. Many other substances also coagulate albumen, such as alum, nitric acid, methylated spirit, and many metallic salts. When albumen is treated with silver nitrate, an insoluble compound is precipitated containing silver. This compound is either a salt, or double compound, of the silver and albumen, and it is generally termed silver albuminate. Under the influence of light it suffers decomposition, forming brown-red reduction compounds. The sensitive surface of albumen paper consists of a mixture of silver chloride, silver albuminate, together with an excess of silver nitrate.

GELATINE.

When bones, hoofs, etc., are submitted to the action of superheated steam, various nitrogenous substances are extracted, which separate from their watery solution as a jelly on cooling. In this form it is termed "size." If it is dried a hard mass results, forming the glue of commerce, by the purification of which the gelatine is obtained. Isinglass is a form of gelatine obtained from the air-bladder of the sturgeon. So far, no molecular formula has been assigned to gelatine, but from what has been ascertained,

it appears to contain a great number of atoms in the molecule. Tannic acid precipitates gelatine from its aqueous solutions as gelatine tannate, a brownish-yellow sticky substance. Gelatine swells considerably in water, but does not dissolve till heated. On cooling, it separates as a gelatinous mass. According to Eder a good specimen should produce a firm jelly when a 4 per cent. solution is cooled down to 20° C. On boiling with dilute acids, or alkalis, gelatine undergoes decomposition producing complex mixtures of amido fatty acids. Aqueous solutions of gelatine slowly decompose on standing, producing ammonia, and substituted ammonias.

PHOTOGRAPHIC EMULSIONS.

As already stated, solutions of gelatine have the property of gelatinising, *i.e.*, separating as a jelly, on cooling, and it is this property which makes that substance so important in preparing photographic emulsions. A gelatino-haloid emulsion consists of a solution of gelatine in water, of such a degree of viscosity that a finely divided precipitate of silver haloid is kept in a state of suspension. This is secured in practice by heating a solution of gelatine with silver nitrate, potassium iodide, and bromide, and then allowing to set.

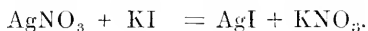

A very important point must be noticed here; that is, to have sufficient of the potassium haloids to precipitate all the silver. Unless this is done the silver nitrate combines with some of the gelatine to form a double insoluble compound, which undergoes some decomposition during the heating. When plates covered with such an emulsion are developed, this silver "gelatino-nitrate" attacks the developer and causes a general fog. Gelatine and collodion emulsions have to undergo a process of ripening in order to increase their sensitiveness to light; this will be considered later on.

HARDENING OF GELATINE.

The various alums, such as ordinary potash alum and chrome alum, and formaldehyde or

formalin, have the property of rendering gelatine hard, and making it insoluble in water. Hence the use of these substances for the prevention of "frilling."

Chromium compounds have also this property, especially in the presence of light, and this is taken advantage of in the various bichromate printing processes. According to some experiments of R. Namias ("Chem. Centr." 27-868), a film of gelatine dipped in a 5 per cent. solution of potassium or ammonium bichromate, and then dried and kept in the dark, was not rendered completely insoluble till after the expiration of some months. In the presence of light, however, the change was much more rapid. By the action of a solution of basic chrome alum upon a mixture of gelatine and casein (albumen from milk) very hard masses were obtained, having different colours.

CYCLIC OR AROMATIC COMPOUNDS.

The most important cyclic substances used in photographic work are the developers, pyrogallol, hydroquinone, metol, amidol, etc. Before these compounds are considered it is necessary to have some idea of the properties of a few simple cyclic substances, the nomenclature used, etc.

BENZENE. C_6H_6 .

This is the parent hydrocarbon from which an immense number of cyclic compounds can be derived. Benzene is of very stable behaviour towards chemical reagents. The halogens act in two ways towards the hydrocarbon: (1) they replace hydrogen atoms (substituted compounds); (2) they simply add themselves on to the benzene (additive compounds).

- $$\begin{aligned} (1) \quad & C_6H_6 + Cl_2 = C_6H_5Cl + HCl \\ & C_6H_5Cl + Cl_2 = C_6H_4Cl_2 + HCl \quad \text{etc.} \\ (2) \quad & C_6H_6 + Br_2 = C_6H_6Br_2 + HBr \\ & C_6H_6Br + Br_2 = C_6H_6Br_2 + HBr, \text{ etc.} \end{aligned}$$

Another point to be noticed is that benzene does not polymerise. If the properties of benzene are compared with those of the fatty or open chain compounds they are found

to differ in a very marked manner. Consequently the constitution of benzene cannot be represented as related in any manner to the open chain hydrocarbons.

CONSTITUTIONAL FORMULA OF BENZENE.

When benzene is treated with reagents so as to obtain substituted compounds, substances are obtained, in all cases, containing six atoms of carbon in the molecule. Thus:

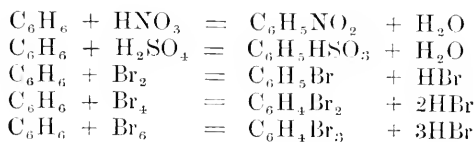

These facts, and a host of others, have led chemists to believe that in the molecule of benzene a stable ring of six carbon atoms is present, each carbon atom having attached to it an atom of hydrogen. The formula is thus represented:

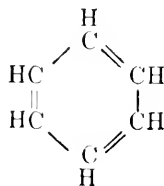

The constitutional formula so written is usually termed Kekulé's formula, as this chemist first brought it forward to account for the behaviour of benzene. By its means the reactions and isomerism of benzene, and its derivatives, can be satisfactorily accounted for.

DISTINCTION BETWEEN BENZENE AND BENZINE.

Benzene is used directly in photography as a solvent. Attention may here be drawn to the distinction between benzene and benzine, since both these substances are used as solvents, and apparently a great amount of confusion exists as to the identity of the two. Benzene, the compound at present under consideration, is obtained during the distillation of coal tar. Benzine is a mixture of open

chain paraffin hydrocarbons, a totally different substance. Indirectly, benzene is used in the preparation of most of the organic developers and coloured substances used in colour photography.

BENZENE DERIVATIVES.

By replacing one or more hydrogen atoms in the benzene molecule, by other atoms, or groups of atoms, various derivatives are obtained. The introduction of hydroxyl groups produces the various phenolic bodies :

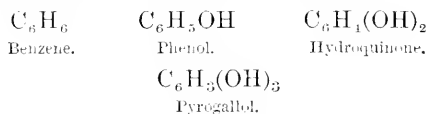

These compounds are acid in behaviour, consequently they dissolve in alkalis. They are designated mono, di, tri hydric phenols according to the number of hydroxyl groups present.

PHENOL OR CARBOLIC ACID.



This compound is obtained during the distillation of coal tar. It is the simplest phenol and readily dissolves in alkalis. It is employed as a preservative in solutions of albumen or gelatine, and for mountants.

DI-HYDRIC PHENOLS.

In the di-hydric phenols the question of isomerism has to be considered. Three isomers are met with, their existence being due to the position of the hydroxyl groups in the benzene molecule. On examining the constitutional formula for benzene it will be noticed that each hydrogen atom occupies the same relative position in the molecule.

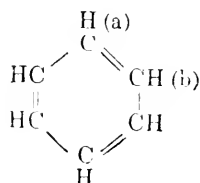

Benzene

The (a) hydrogen atom is united to a carbon atom, which is itself united to two CH groups. The (b) hydrogen atom is united also to a

carbon atom, which is itself united to two CH groups, and similarly with regard to any other hydrogen atom. It follows from this that all the hydrogen atoms are identical as regards their combination with the carbon. Replacing one hydrogen atom by OH produces phenol. Because of the interequivalence of the hydrogen only one phenol should exist, and actually this is so.

ISOMERIC DI-SUBSTITUTION PRODUCTS.

Replacing two hydrogen atoms by hydroxyl groups, it will be seen that three different compounds should be possible.

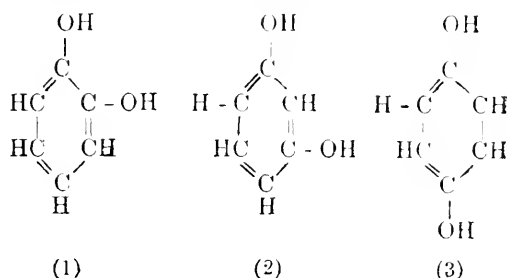

In (1) the two OH groups are next to one another ; in (2) one CH comes between them, and in (3) two CH groups. Actually, three compounds are known, having different chemical and physical properties, yet all having the molecular formula $C_6H_4(OH)_2$. These three substances are pyrocatechol, resorcinol, and hydroquinone. In order to distinguish between three isomeric di-hydroxy-benzenes they have received special names. Formula (1) is termed the *ortho*, (2) the *meta*, and (3) the *para* derivative.

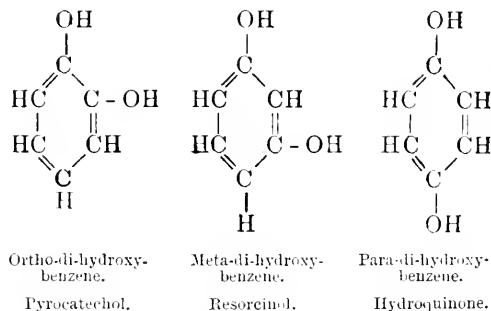

All these compounds can act as photographic



PRINT FROM BLUE BLOCK ONLY.



PRINT COMBINING RED AND BLUE.

developers, but the most important is the para-derivative, hydroquinone.

HYDROQUINONE.

Para-di-hydroxy-benzene.

This compound was first suggested as a photographic developer by Captain Abney in 1880. It acts more slowly than pyrogallol, and produces harder negatives. It is most conveniently prepared by reducing a body known as quinone (obtained by oxidising aniline $C_6H_5NH_2$) with sulphurous acid.

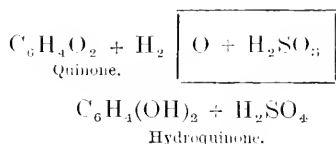

Hydroquinone is di-morphous and dissolves readily in water. Its aqueous solution is coloured brown with ammonia. Oxidising agents convert it into quinone.

TRI-HYDROXY DERIVATIVES OF BENZENE.

These compounds exist in three isomeric forms, produced, like the di-hydric phenols, by the position of the hydroxyl groups in the benzene molecule.

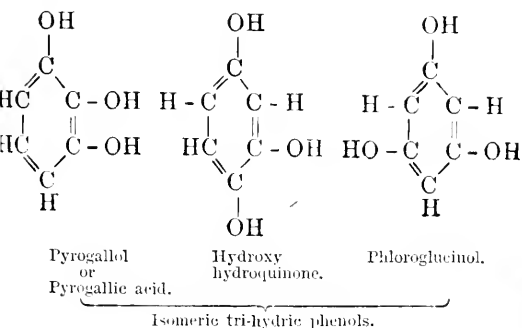

PYROGALLOL.

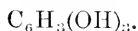

This is the only compound of the three isomeric substances used in photographic work. It melts at $132^\circ C.$, and is produced by heat-

ing gallic acid. The reaction expressing the change is this :

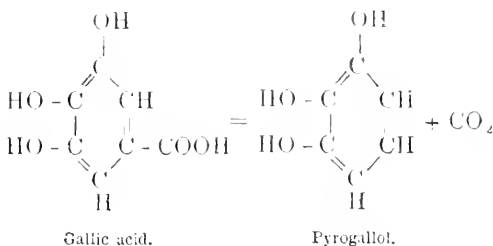

Or it may be written :



Pyrogallol is extremely soluble in water, and with more difficulty in alcohol and ether. Its alkaline solutions absorb oxygen with great readiness, carbon di-oxide, oxalic and acetic acid, and various brown colouring matters are produced during the oxidation. A blue colour is imparted to pyrogallol solutions by ferrous sulphate, and a red by ferric chloride. An iodine solution is turned a purple red on the addition of an aqueous or alcoholic solution of pyrogallol. The latter is a powerful reducing agent, readily precipitating gold, silver, and mercury from their solutions.

Its use as a photographic developer was first suggested by Liebig and Regnault in 1851. Pyrogallol is a very powerful developer when in alkaline solution, and in practical work its action has to be kept under control by the use of a restrainer, usually a bromide.

AMIDO-PHENOLIC SUBSTANCES.

These compounds are, like the di- and tri-hydric phenols, used in photography as developers. If ordinary phenol is taken and treated with nitric acid, under the proper conditions, a mixture of ortho and para-nitro-phenols is obtained. That is, a hydrogen atom in the phenol is replaced by a nitro group, NO_2 .

It must be carefully noted that only hydrogen connected with a carbon atom of the benzene ring is replaced by the nitro group: the hydroxylic hydrogen remains intact; this is proved by the increased acid properties of the compound formed.

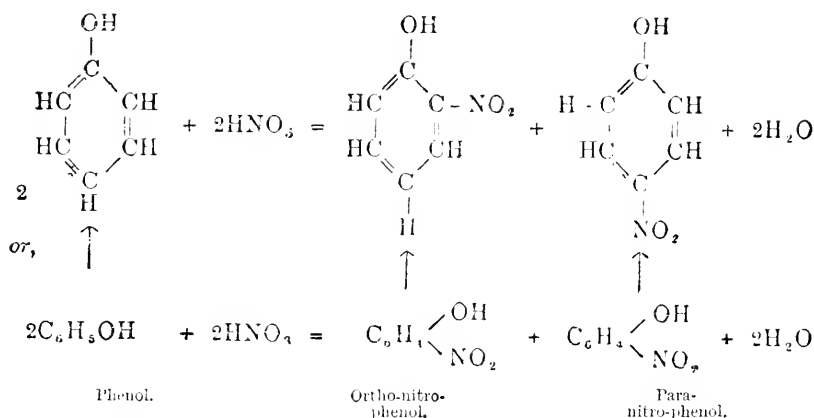

If the para-nitro-phenol is then separated and treated with any reducing mixture the nitro group (NO_2) is converted into an amido group (NH_2), and para-amido-phenol results. Thus —

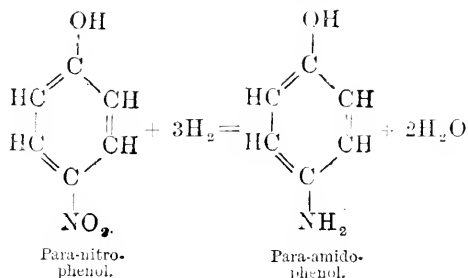
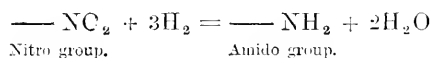

These amido-phenols are both basic and acid in character. The hydroxyl group confers acidic, and the amido group basic properties upon the compounds.

RODINAL.

This developer is a strong solution of the hydrochloride of para-amido-phenol. The hydrochloric acid unites with the amido group.

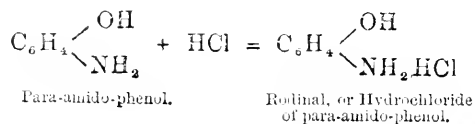

DI-AMIDO-PHENOLS.

By introducing two nitro groups into ordinary phenol, or another nitro group into para-nitro-phenol, di-nitro-phenol is obtained.

This compound, on treatment with reducing agents, is converted into di-amido-phenol. The change taking place may be represented as follows:—

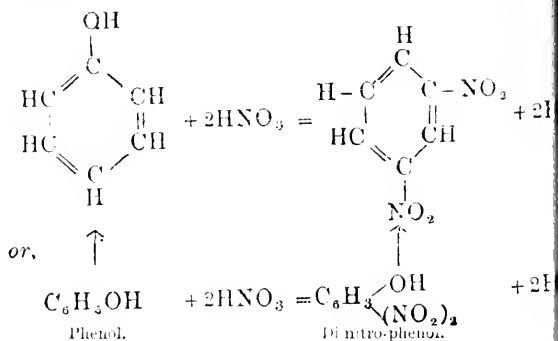

On reduction:—

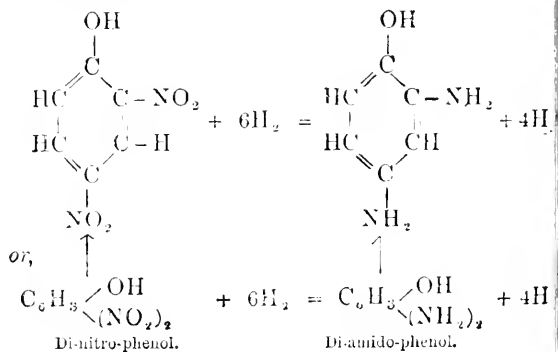

AMIDOL.

The salts of di-amido-phenol are employed in photography under the name of "amidol," as developers. It is a powerful reducing agent but is very unstable, and does not keep for any length of time. It might be noted here that the greater the number of amido groups a developer contains, the more unstable it becomes.

METOL.

Another important developer deserves consideration in connection with these amido phenolic bodies, namely, metol. This compound is a derivative of methyl phenol, or, to give it its common name, cresol.

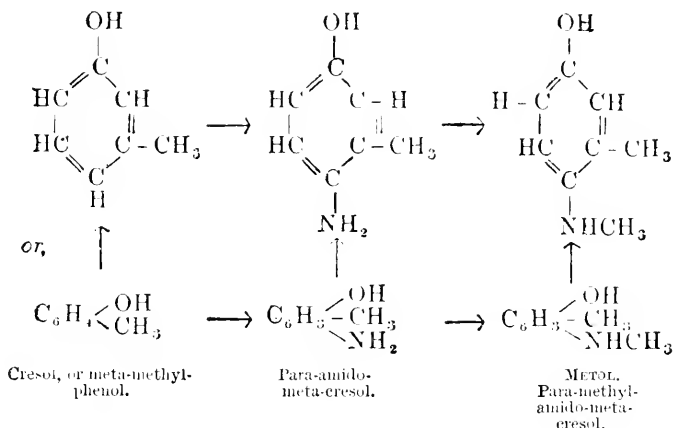

Metol is an excellent developer, and is preferred by many photographers to pyrogallol. It is sold as the sulphate of the base.

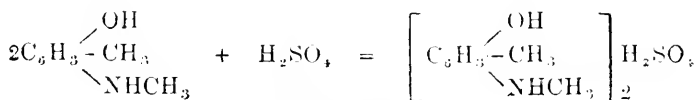

Metol developer.

NAPHTHALENE, NAPHTHOL, ETC.

Another important aromatic or cyclic compound is the hydrocarbon naphthalene. It is not proposed to consider how the constitutional formula for this compound has been deduced; the photographer is referred to a text book on Organic Chemistry. Its constitution is best represented by the following formula:—

Naphthalene:—

Molecular formula,



Constitutional formula

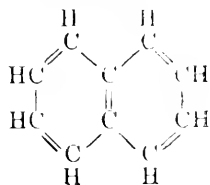

This hydrocarbon, it will be noticed, consists of two benzene rings joined together. Like benzene it forms phenolic bodies (naphthols) and amido-phenolic substances (amido-naphthols) similar in properties to phenol and amido-phenol. The isomeric derivatives of

naphthalene are very numerous, one substituent yielding two isomeric compounds. In this particular it differs essentially from benzene.

EIKONOGEN.

One important derivative of naphthalene, from a photographic point of view, is the developer eikonogen.

This was discovered by Professor R. Meldola, and placed on the market as a photographic developer by Dr. Andresen. Its preparation from naphthalene would be too

complex to consider here. Its constitutional formula is as follows:—

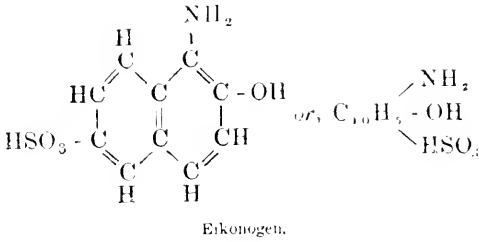

It will be noticed that the developer contains three groups—an amido group (NH_2), a

hydroxyl group (OH), and a sulphonic acid group (HSO_3), united to a naphthalene residue. The HSO_3 group is very acid in character, and readily forms salts with alkalis. The developer is not very soluble in water, and its solutions do not keep very well. It is particularly useful for the development of under exposed plates, owing to the softness and absence of chalkiness characteristic of its results. It would appear that only those compounds which contain the basic and hydroxyl groups in the "para" position are remarkably effective as photographic developers. Thus showing how intimate is the connection between photographic behaviour and chemical constitution.

PORTRAITURE.

INTRODUCTION.

PRACTICALLY the first important application of photography was its use in portraiture, and, although the camera is now employed for an almost incredibly large number of other purposes, the former still remains that with which it is, perhaps, most identified in the public mind. The production of good and artistic portraits is by no means an easy matter, but requires considerable practice, unlimited patience, and a liberal dower of good taste. Many workers, indeed, would cheerfully assent to the pronouncement that this branch of work is by far the most difficult which the photographer can be called upon to undertake—providing, of course, that the attainment of a high standard is aimed at, for the production of mere commonplace “photographs of people” is a fairly simple matter. In the better class of work there is undeniably ample scope for the highest Art training and skill.

INDOOR AND OUTDOOR PORTRAITURE.

The requirements for indoor and outdoor work are naturally different. For the former, a studio, or, at any rate, a window suitably arranged for regulating the light, is indispensable, unless artificial light is employed. In the usual run of outdoor portraiture, on the other hand, all such accessories are absent, and the lighting has to be arranged for by judicious choice of position. The main principles of working are, however, very much the same in both, and they may well be studied together. The plan will therefore be adopted in the present chapter of considering portraiture as a whole, simply pointing out, as they occur, the factors

of variation belonging to different classes of work and the usual procedure in dealing with these.

THE STUDIO.

The position of the studio should be chosen, if possible, so that a north light is obtainable, with just a tendency towards the north-east. This provision is intended to secure that the sun shall not shine directly into the studio during ordinary working hours. It is true that many operators are obliged to work in studios which contravene this condition, and yet succeed in turning out excellent portraits. These cases must, however, be regarded as instances of triumph over difficulties, rather than contradictions of the general truth that a north light is best. It is an advantage to have the skylight at an angle of not less than 62° —the meridian altitude of the sun on the longest day. It is certainly desirable for the studio to be on the ground level, owing to its greater accessibility; the second best place is probably on the first floor; thirdly, admirably situated as far as light is concerned, but undeniably hampered as regards convenience, comes the top of the house or the roof.

DIMENSIONS OF STUDIO.

The size of the studio will, of course, depend upon the space available. It is certainly wise to have it amply large. A good length would be from 26 to 30 ft., by about 14 ft. wide. It is inadvisable for it to be less than 20 ft. long by 10 ft. wide. Fig. 599 shows the section of a studio planned on what may be called the old style, although it is still that most in use, at any rate, by the generality of

professional photographers. If the studio joins on to a building, a flat leaden roof is best for the unglazed part, which may be used for printing, if desired. Many of the higher class modern workers have abandoned the old form of studio altogether, preferring to use what is practically an ordinary large room, glazed on the north side from the top to within about 4 ft. of the ground. It is obvious that this form of studio has many advantages, among which may be named freedom from damage to the glass, or obstruction of the light, by hail or snow, greater convenience and naturalness in the arrangement of the furniture and

found by far the most waterproof, and will not require so much future attention and repair. If the studio has not a north aspect it will probably be necessary to use ground instead of plain glass, to keep out the sun's rays. Many workers prefer ground glass in any case, on account of the softer and more diffused light obtainable, besides which it serves to block out any unpicturesque surroundings.

FITTING UP BLINDS, ETC.

Spring-roller blinds, preferably of dark blue or green lining, and about 2 ft. wide, should be fitted along the top of the studio

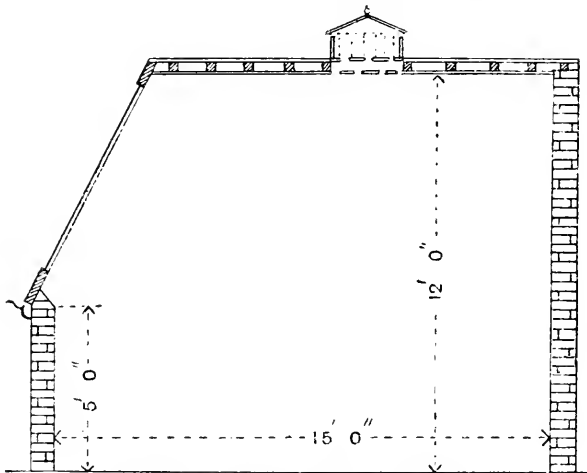

Fig. 599.—SECTION OF SLANT LIGHT STUDIO.

accessories, less difficulty with the blinds, and impossibility of leakage in wet weather.

GLAZING.

If the studio is to be one of the old sky-light variety it should be glazed only where the light will be required, and all unnecessary glass avoided. For example, with a north light, the south side and both ends should be opaque, only the north side being glazed. Large panes of glass are desirable, so that as little light as possible may be obstructed by sash-bars. It is recommended that one of the patent systems of glazing without the use of putty should be adopted, as this will be

light, and provided with cords, so that they are perfectly under the control of the operator. The sides should overlap, so that the light cannot penetrate between them. Unless a side light with curtains is contemplated (a plan which is not nowadays much in vogue), an additional set of blinds must be arranged to work from the bottom, and controlled by means of cords passing over pulleys above (see Fig. 600). It is thus rendered possible to obtain a concentrated light at any height and in any desired amount. Where this plan cannot be adopted, owing to the expense, good work may be accomplished with a system of curtains, of any suitable dark material, sliding on rods or cords.

SUN BOARDS AND SUN-TRAPS.

Where the studio has not a northerly aspect it is often possible to prevent trouble from direct sunlight by means of a large board, or even blind, so placed as to cut off the undesirable rays. There are many different ways of doing this, varying according to situation and requirements. Boards or blinds may be fixed at an angle on the studio itself, either permanently or so that they may be easily removed when not required; temporary screens may be provided, or if the photographer has the space at command, and the requisite permission, a sufficiently high hoarding or wall may be built. It is impossible to give more than general hints on this subject; it is simply a matter for the exercise of a little common sense. The worker has merely to note how and when the sun makes itself objectionable, and to take suitable measures to screen or shade it off, using due caution, at the same time, that the ordinary light of the studio is not thereby injuriously interfered with.

VENTILATION AND HEATING.

Due attention must be paid to ventilation and heating, or the studio will be extremely uncomfortable in both summer and winter. The ideal method of introducing fresh air is certainly by means of electric fans, but unfortunately these are not accessible to all. Any ordinary system of ventilation provided at the ridge of the roof, and somewhere along the bottom walls of the studio, should be satisfactory, care being taken that light is not admitted where it is liable to conflict with the main illumination of the sitter. Small windows are very suitable, provided the last requirement is kept in mind, or secured by means of opaque blinds. It is necessary to guard against a common mistake, often not perceived till too late—that of placing the ventilators where they will allow the entrance of rain, etc. The heating of the studio presents no particular difficulty. A small gas stove with a suitable flue may be recommended as perhaps the most satisfactory; this should not be placed in

proximity to any woodwork, nor where it will cast reflections.

BACKGROUNDS.

In artistic portraiture a good deal depends upon the employment of suitable backgrounds. These may be obtained in very large variety, either plain, graduated,

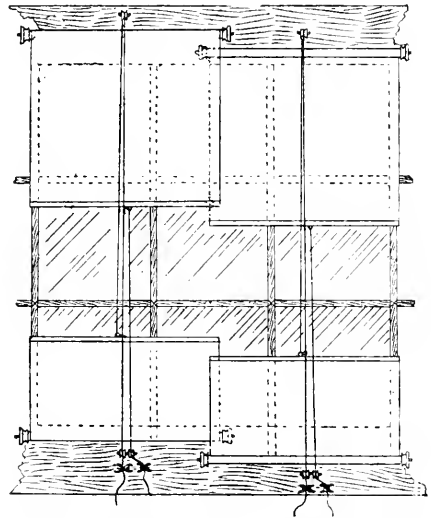

Fig. 600.—ARRANGEMENT OF STUDIO BLINDS.

clouded, or scenic, and are commonly painted in distemper or oil on canvas or stout paper. The background used for vignette heads may be either a plain one of a light tint or painted to represent clouds, and is usually stretched on a small frame, so that it may be conveniently placed in any part of the studio. Full length and group backgrounds are, of course, larger, and are either hung on rollers over a suitable frame with bottom supports, or stretched and nailed tightly over it. Fig. 601 shows an excellent form of stand now obtainable which will hold a number of backgrounds on rollers, any one of which may be raised to the top and unrolled as desired. Scenic backgrounds should be quiet and unobtrusive in character, and always kept strictly secondary in importance to the sitter. Fig. 602 affords a typical example of a

tasteful and effective, yet subdued description.

FURNITURE AND ACCESSORIES.

The furniture of a studio intended for professional use should be such as would be seen nowadays in a well-arranged

following manner:—Well soak waste paper in a paste made of $1\frac{1}{2}$ lbs. of flour, 2 table-spoonsful of alum, and 1 gallon of water, thoroughly mixed and boiled. The ingredients should be incorporated till a mass as thick as putty results; this will harden like papier maché. A rough framework of wood may be used to build on, and the

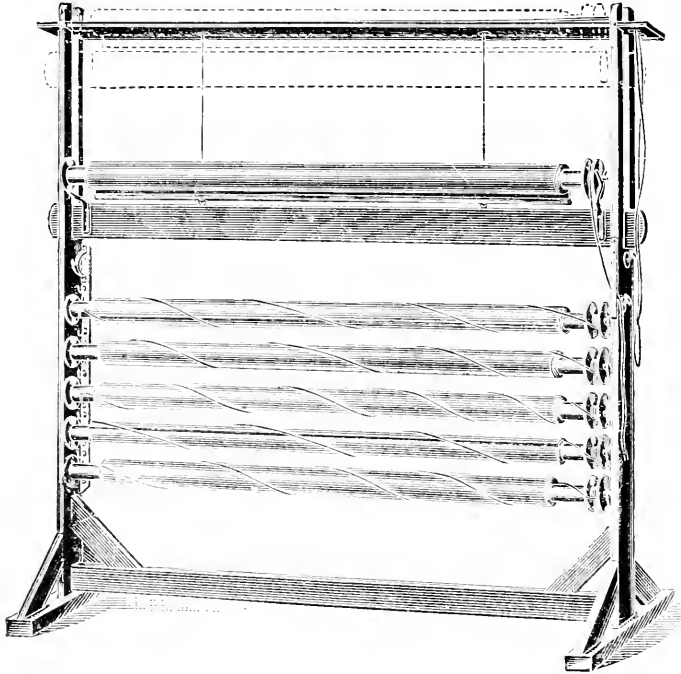

Fig. 601.—SPECIAL BACKGROUND STAND.

modern drawing-room, except that it is convenient that no two articles should be alike. The ideal should be lightness and elegance of line, rather than heaviness and ornateness. The amateur, of course, will not need the same variety and extent of furniture and accessories, but sufficient has no doubt been said to indicate the direction in which his requirements should tend. The hideous and unsightly columns and pedestals of a bygone era cannot be too studiously shunned, but rockwork and rustic accessories of a natural and unaffected kind are often useful. These may be purchased or, if desired, built up in the

mixture may then be moulded into any desired shape, which, when dry, may be painted over.

TREATMENT OF WALLS, ETC.

The method in which the walls of the studio are treated is largely a matter of taste, provided that a colour or covering likely to cause reflections is avoided. A neat grey paper is very suitable, or the whole of the studio may be painted a fairly dark green. Hangings of art muslin are inexpensive and effective, but tend to collect dirt and dust. The walls may, if desired, be hung with specimen photo-

graphs in frames. The floor should be either polished, stained, or linoleum covered, since a carpet offers too much obstruction to the free movement of the camera and accessories.

REFLECTORS AND HEAD-SCREENS.

Since the lighting of an ordinary studio is obtained from one side only, the portion

series of useful reflectors is illustrated by Fig. 605. If the light in the studio is strong, it is inadvisable to have too white a reflector, or the shadows on the face will look chalky and glaring, and disagreeable lights will appear in the eyes. Many workers prefer to use a reflector of a greyish or yellowish tinge, on account of the softer results said to be obtainable. One reflector is generally sufficient.

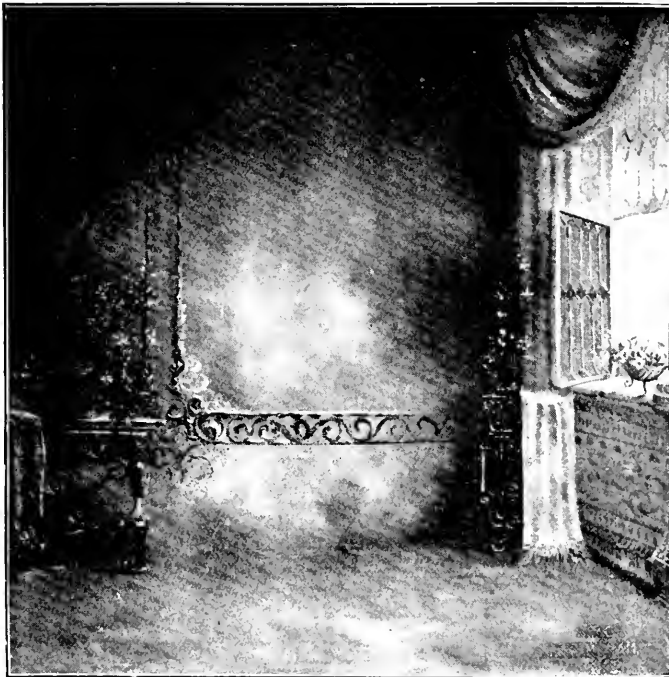

Fig. 602.—TYPICAL SCENIC BACKGROUND.

of the face on the side away from the light would be in too heavy shadow without the use of a reflector. This is simply a fairly large frame, covered with white or light-coloured material, and arranged to stand at any desired angle (see Fig. 603). Another pattern of reflector which is double, and enables more control to be obtained over the amount and direction of the reflected light, is shown by Fig. 604. A head-screen is often useful for cutting off an excess of top light, and for other purposes; an ingenious combination which may be employed as a head-screen or as a

ARTIFICIAL LIGHT.

An increasing number of studios are now worked in part or exclusively by artificial light. In some cases this is because the situation is unfavourable to the use of daylight, and it must be admitted as an advantage of an artificial illuminant that it enables almost any kind of premises to be employed for photographic purposes, without any necessity of building a special studio, or troubling about aspect or locality. Another point secured by this procedure is absolute

independence of the weather, which often seriously hampers the daylight operator. On the other hand, while granting the great convenience of an artificial lighting installation for occasional use, it must be

various systems of artificial lighting, and it is likely that its employment for portraiture will maintain a steady increase.

ELECTRIC LIGHT.

The most convenient and satisfactory system of artificial lighting for the studio

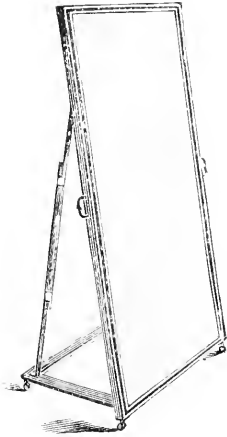

Fig. 603.—ORDINARY REFLECTOR.

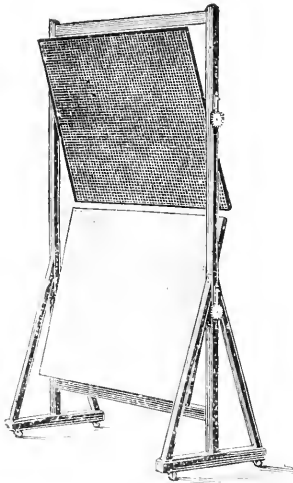

Fig. 604.—DOUBLE REFLECTOR.

noted as a serious source of additional expense, and, whatever may be maintained to the contrary by its partisans, the results obtained cannot be advantageously compared with those taken by daylight. For all that, much excellent work is being done by exponents of the

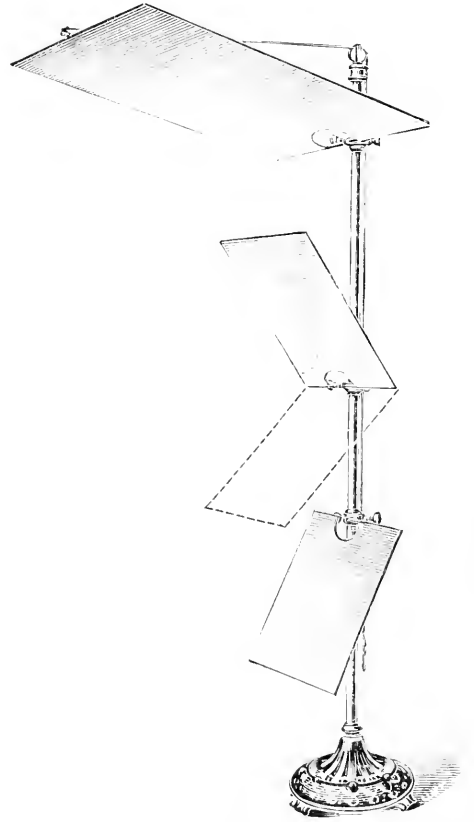

Fig. 605.—COMBINED HEAD-SCREEN AND REFLECTORS.

is certainly that which depends on electricity, either arc or incandescent. It is questionable which is to be preferred; the former is the most powerful and more generally employed, but many workers maintain that the incandescent system, properly used, will give softer and better results. A good deal depends upon the current available, and the whole subject is one for consideration not only from a

photographic point of view, but in the light of advice from a practical electrician. A good arrangement of the arc light for studio use is shown by Fig. 606; the method of swinging the concave reflector to any angle, and the counterpoise which balances the arrangement at the desired height, will be noticed. Another excellent form is shown by Fig. 607. At A (Fig. 608) is seen a rackwork contrivance which adjusts the angle of the reflector. The efficiency of the arc light depends on the correct adjustment of the carbons, and a

of heat is evolved, and, unless a large number of burners are used, the exposure is rather long. Attention should be given to securing a sufficient pressure of gas.

MAGNESIUM FLASHLIGHT.

The powerful and peculiarly actinic light evolved during the burning of magnesium

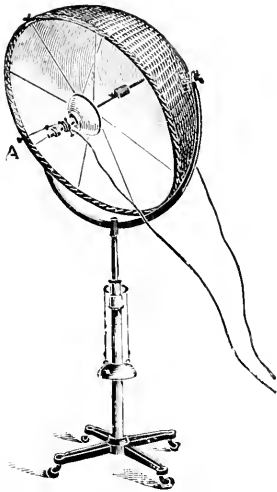

Fig. 606.—STUDIO ARC LAMP.

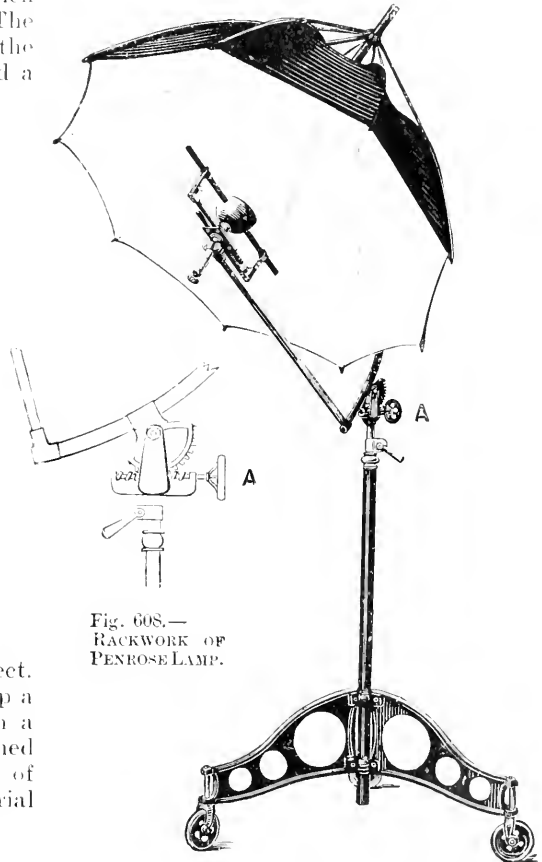

Fig. 608.—
RACKWORK OF
PENROSE LAMP.

Fig. 607.—THE PENROSE STUDIO ARC LAMP.

little practice is required in this respect. In the incandescent form of studio lamp a large number of bulbs are enclosed in a concave reflector, the light being softened and diffused by means of a screen of muslin or other translucent material fastened in front.

INCANDESCENT GAS.

The incandescent gas light may be successfully employed for portraiture, for which purpose a sufficient number of burners are fixed in rows within a large white reflector. Suitable fittings are obtainable, or can readily be made with a certain amount of contrivance. The lighting is satisfactory as regards softness and modelling, but a considerable amount

renders it well adapted for photographic purposes. It is generally employed in the form of powder, either forced rapidly through a stationary flame by means of a sudden and strong artificial draught, or incorporated with certain rapidly igniting chemicals, such as chlorate of potassium, so that the mixture will burn instantaneously on the application of a light. Such

compounds are, however, hardly suitable for use in a lamp, on account of the risk of explosion, but should be burned in the open. Spreading the magnesium powder on gun-cotton is a satisfactory method of ignition, but requires extreme caution: it is better in such a case to fire it by means of electricity, and to keep it at a safe distance. Magnesium produces a certain amount of dense white smoke during combustion, and this has sometimes been found inconvenient. The objection may, however, be overcome by means of adequate ventilation, or by trapping the

A lens of large aperture should be used, and focussing may be done by the aid of a paraffin lamp or gas burner held near the face, or even by means of a candle held level with the latter. Care should be taken to shade the lens from the direct light of the magnesium by means of a screen or a cloth thrown over parallel rods attached to the sides of the camera. The most rapid plates should be employed, preferably backed. The "Warwick-Brookes" flashlight apparatus has an electric ignition, and gives an instantaneous flash the moment the switch is

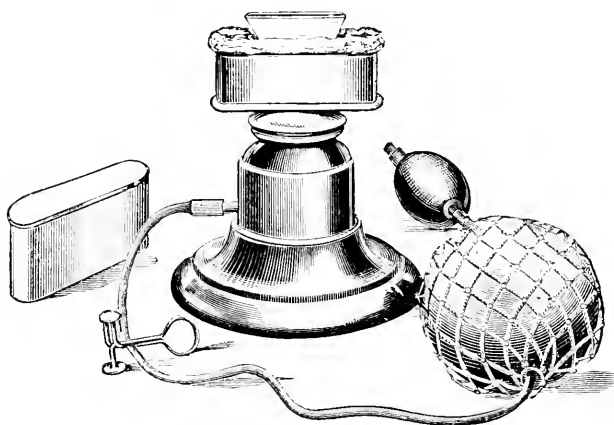

Fig. 609.—THE "TODD-FORRET" MAGNESIUM FLASH LAMP.

smoke in a box immediately after each exposure. There are several patterns of lamps in the market which make provision for removing the smoke difficulty, and there are also various patent flash mixtures which are guaranteed smokeless.

FLASH LAMPS.

A convenient and trustworthy lamp, which will give either instantaneous or short continuous exposures, is shown by Fig. 609: it is known as the Todd-Forret. Unless the light can be very well reflected or diffused it is better to have more than one lamp when using magnesium for ordinary portraiture, or, on account of the manner in which the illumination is concentrated, the shadows will probably be too heavy or the modelling unsatisfactory.

Another recently introduced lamp, the "Ideal," has an ingenious ignition device in which the pressure of the same pneumatic bulb which actuates the camera shutter explodes a percussion cap inside the lamp. The latter is arranged on a portable stand adjustable to any height, and has a cabin or cover of prepared cloth which effectually traps all the smoke. The front of the cover forms a light diffuser, by the aid of which a remarkably soft yet intense illumination is obtained. This apparatus, which is shown by Fig. 610, is highly spoken of, and is already in use by many photographers, both for ordinary work and for taking large groups in halls, etc. It is also eminently suitable for "at home" portraiture, for which purpose it is frequently found to give better results than daylight.

A HOME-MADE FLASHLIGHT INSTALLATION.

The installation to be described is a simple one, but it will yield satisfactory results. Very little description of the illustration (Fig. 611) is required. The base A must be made of heavy wood, and the feet may be of iron, or may be weighted to make the whole firm. The rising post B, sliding in the base as shown, carries two arms C and D pierced with

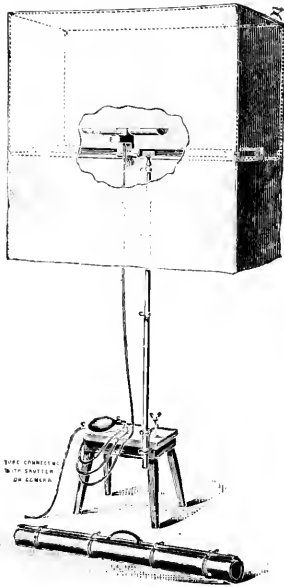

Fig. 610.—HOUGHTON'S "IDEAL" PORTRAIT LAMP.

holes at E, F, G, and H. Fasten staples as at X to hold the tin reflectors I (see also Fig. 612) tightly in position. Procure a dozen clay pipes with bayonet-shaped mouthpieces; a single pipe fitted with a horn mouthpiece and a metal band connecting it with the clay pipe can be obtained for a penny. Fix the metal bands and mouthpieces at E, F, G, and H as shown. The mouthpieces are then connected with rubber tubing and Y junctions. The junctions can be made of brass or glass tubing, the former, of course, being preferable. The whole is thus connected with a bicycle pump P. Around the bowl of

each pipe J (Fig. 612) cotton-wool K should be loosely wound with fine wire.

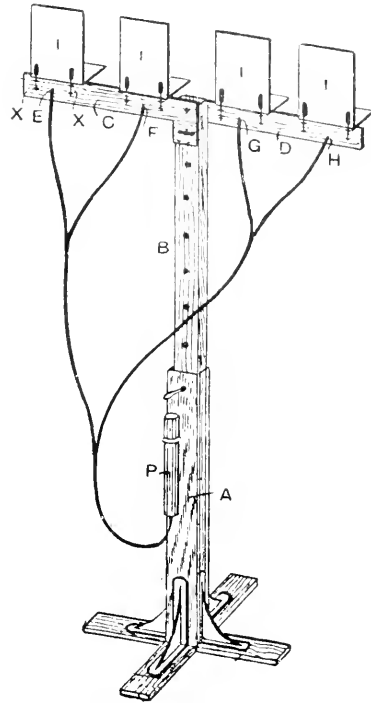

Fig. 611.—HOME-MADE FLASHLIGHT APPARATUS.

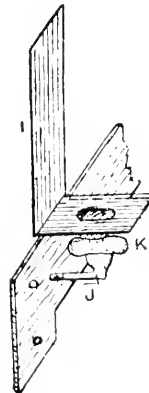

Fig. 612.—METHOD OF PLACING PIPES AND REFLECTORS.

RULES FOR FLASHLIGHT PORTRAITURE.

The camera should generally be about on a level with the chin of the model, and the

lamps are usually about 1 ft. above it and slightly to one side, so that the light falls at an angle of about 60° , and is about 6 ft. from the figure. A suitable arrangement is shown by the diagram (Fig. 613): A A are four lamps, B reflectors, C sitter, D background, and E camera. The light must be outside the field of view. Various modifications may be adopted with more lamps. The usual plan is to have a general, even, or diffused light, and a principal illuminant to pick

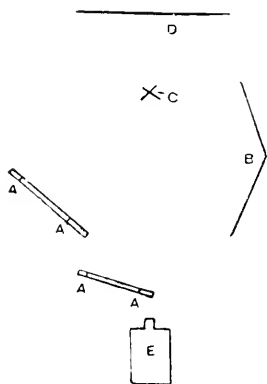

Fig. 613.—ARRANGEMENTS FOR FLASHLIGHT PORTRAITURE.

out the high lights and give force to the figure. Let the wool around the pipes soak up some spirit from the saucer, and in each pipe put with a spoon about 5 gr. of magnesium powder. Then pose the model 3 ft. from the background to avoid the cast shadow, choosing if possible a profile view of the face, and always looking away from the light; get an assistant to hold a lighted taper, first above the head and then at the feet of the figure, and focus it sharply and insert a stop. Insert and draw the slide. Now run the taper along the pipes to light the cotton-wool, and let the assistant light up a couple of inches of magnesium ribbon held in pliers or between two coins. As soon as the ribbon is well alight, discharge the pump smartly, and the powder will be sprayed from the pipes through the spirit flame, a brilliant illumination resulting. Flashlight groups require lamps of greater

power, or a larger number of the ordinary kind. Care is necessary in disposing the lamp or lamps so that the whole of the group may be equally illuminated. The sitters should be told not to look in the direction of the lamp, or they will probably half close their eyes at the moment of exposure. Although it should be seen that they are all prepared and properly arranged, it is better if they are not anticipating the exact moment of exposure. Plate XV., facing p. 193, is an admirable example of a large flashlight group.

THE OXY-MAGNESIUM LIGHT.

The Platinotype Company supply a lamp for burning magnesium ribbon in a glass vessel filled with oxygen, thus producing an intensely actinic light. The oxygen is obtained from a cylinder, or by any other practical method, and passed first into a gasholder below the lamp, and then into the glass vessel containing the magnesium ribbon. The exposure is made by means of electricity, which is caused to ignite a fuse at the end of the magnesium. The apparatus has been received with much favour, and gives beautifully soft and natural results.

ACETYLENE.

Acetylene is now a good deal used for portraiture. There are various forms of generators, in which the gas is obtained by the action of water on calcium carbide. A square or concave reflector is employed, in which are arranged a number of burners, and the amount of light can be adjusted by means of a stopcock. In practice, however, it is better to work the burners at full pressure. The light is easy to manage, and in careful hands is very satisfactory. An objection with some is the disagreeable smell given off by the gas, which, however, many do not notice. Some caution is required in the storage of calcium carbide, which must on no account be kept in a damp place; also a good pattern of generator should be obtained, or the evolution of the gas will be attended with danger.

THE HEWITT MERCURY VAPOUR LAMP.

A light which has lately attracted considerable attention is that given by the Hewitt Lamp, in which a highly actinic illumination is secured by the action of an electric current on mercury contained in a large vacuum tube. The light is peculiarly rich in blue and ultra violet rays, but its general adoption is somewhat likely to be militated against by the fact that the red rays are entirely absent, and that, in consequence, both sitter and surroundings are lit in a strangely weird and ghastly manner. This effect is, of course, merely apparent to the observer, and does not occur in the photograph. The light is well suited for portraiture and gives admirable modelling, a further convenience being that the lamp is so constructed as to be useful for printing and similar photographic purposes.

OTHER FORMS OF ARTIFICIAL LIGHTING.

Ordinary gas burners and even paraffin lamps have been employed for portraiture, but for all practical purposes they may be ruled out of court, as requiring far too long an exposure. Limelight has been successfully tried, and, if a proper reflector is used and the glare screened from the sitter's eyes, is readily workable: it requires, however, some skill to avoid heavy shadows and a chalky, unnatural kind of lighting, besides which it is troublesome and expensive. It is, nevertheless, possible that more will be heard of this light in the future, particularly since it is now so easy to obtain any amount of chemically pure oxygen as required, without the use of cumbersome and heavy cylinders, by the aid of Caumont's Oxygenator, in which the gas is evolved by the action of water on specially prepared blocks of sodium peroxide.

OPERATING WITH ORDINARY DAYLIGHT.

Assuming that a properly designed studio is available, with a suitable and sufficient light, the aim of the operator should be to obtain roundness and softness of modelling in the portrait, while

keeping in due prominence the most characteristic or attractive points of the face. This is to be secured by attention to lighting and careful regard to the pose and expression of the sitter. While a certain amount of relief is necessary, harshness of contrast should be by every means avoided: this is largely a matter of giving sufficient exposure. The great fault of probably the majority of commercial workers is that they give a minimum exposure to their portraits, thus losing the softness, delicacy, and sense of atmosphere which would otherwise have been present.

QUALITY, QUANTITY, AND DIRECTION OF LIGHTING.

The operator should have the lighting of the sitter entirely within his control; that is to say, it should be possible for him, by manipulation and adjustment of the blinds, and choice of position for the camera and model, to obtain any desired effect. This, of course, requires a good deal of practice and experience, and it is an excellent plan to obtain a good plaster bust or statuette and place it in various lights, making a quarter-plate photograph of each position. By this means a considerable quantity of useful information may be gained. The light should not be too strong; if it is found that even when subdued by the use of blinds the portraits obtained are too harsh in contrast, ground glass or tissue paper should be employed as a diffuser. As the amount of light is constantly varying, it is as well to use an actinometer from time to time to ascertain the approximate exposure. The studio should be available for working from either end, if possible, although this is not absolutely essential.

INFLUENCE OF THE BACKGROUND.

The character of the background employed has a considerable influence on the ultimate effect of the picture, other things being equal. This may be readily proved by taking several photographs of a sitter under exactly the same conditions of

posing and lighting, but using backgrounds of different depth. It will be seen that the whole individuality and even modelling of the face may be totally altered by contrasting it with surroundings of an unsuitable tone. The selection of a harmonious and tasteful background is of equal importance in the case of three-quarter and full-length portraits. Anything loud, noisy, or obtrusive in character, or in conflict with the dress and personality of the sitter, should be avoided. The same remark applies to the question of furniture and accessories. All that seems incongruous or out of place, no matter how slight may be the feeling of dissatisfaction or doubt which it arouses, is bound to be artistically wrong and should be instantly altered.

OBTAINING SOFTNESS OF LIGHT.

In lighting the sitter, the operator must constantly remember the great difference which exists between the face as it appears to the eye and the same features when photographed. When the model is facing the camera under the unmodified light of the studio it might perhaps seem to the novice that satisfactory round and soft lighting has been secured. Experience, however, will soon teach him that the shadow side of the face will be heavy and black in the resulting picture, unless it is softened by the use of a reflector, which will not only give just sufficient illumination to the side of the face away from the light, but will also tone down the too pronounced lines under the eyes and elsewhere, and secure a rounder modelling of the features. The reflector, however, must be placed at just the right distance and at a correct angle, or the lighting will be unpleasing. Softness and roundness of lighting is wonderfully modified by the arrangement of the blinds, the distance of the sitter from the source of light, and other factors. In cases of difficulty, where for any reason the modelling is harsh and abrupt, much may be done by the aid of a light muslin head screen, or even a judiciously placed sheet of tissue paper.

TYPES OF FACE, AND RULES FOR LIGHTING.

The sitter should be carefully and tactfully studied before determining on the pose and method of lighting to be adopted. Nearly every person has one side of his or her face more pleasing than the other, and that side should obviously be given the chief prominence. Generally speaking, a three-quarter face is the most satisfactory, but some features look best in profile or perhaps in full face. If the camera is placed above the level of the sitter's head, and pointing downward, the forehead will be given more prominence, and the lower part of the face will seem less important. This should, plainly, never be done in the case of those with heavy foreheads or insignificant chins. On the other hand, if the lens is below the level of the sitter's head, the chin receives more importance and the forehead less; the nose also appears shorter. Fat, plump features should never be taken full face, nor, as a rule, should a thin bony countenance be taken from the side. Where the nose is slightly twisted the face should be turned to the side opposite the direction in which that feature is bent; it is thus frequently possible to entirely avoid any suggestion of the defect in the photograph. Persons with a squint will generally look best in profile, or nearly so. By slightly tilting the sitter's head up or down, greater or lesser prominence may be given to either the lower or upper part of the face as desired; while if it is borne in mind that the well lit portions of the countenance will be brought forward and attract attention, while those in shadow will be, as it were, made to assume quite a secondary importance, it will be in the operator's power to still further augment the effect of good features, and atone for or suppress bad ones, by judicious manipulation of the lighting.

POSING.

The pose of the head and figure is of supreme importance. The slightest degree of clumsiness or ungracefulness will

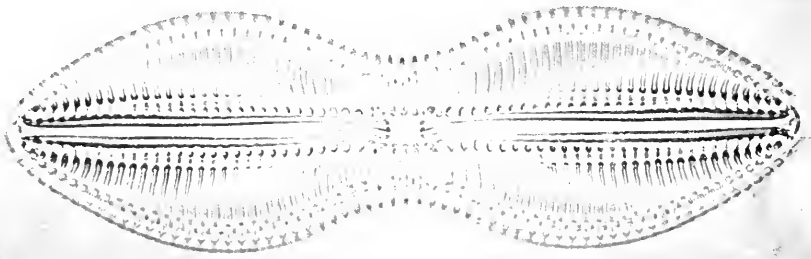

NAVICULA CRABO (x 500 DIA.).
ZEISS APOCHROMATIC OBJECTIVE 3 MM. AND COMPENSATION EYEPIECE 4.

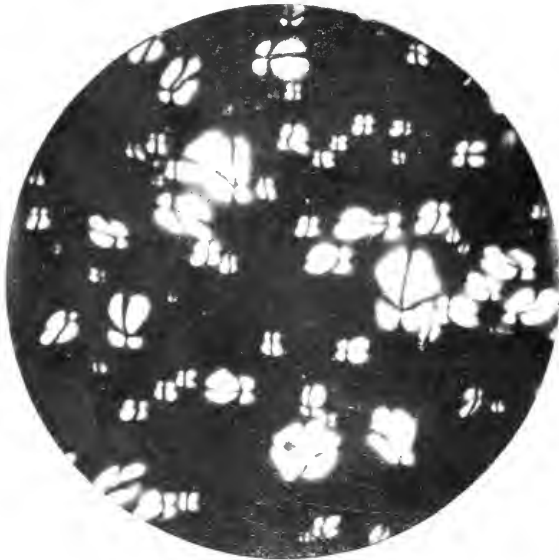

POTATO STARCH (x 170 DIA.)
UNDER POLARISED LIGHT.



DIATOMS. ASTERIONELLA FORMOSA (x 170 DIA.).

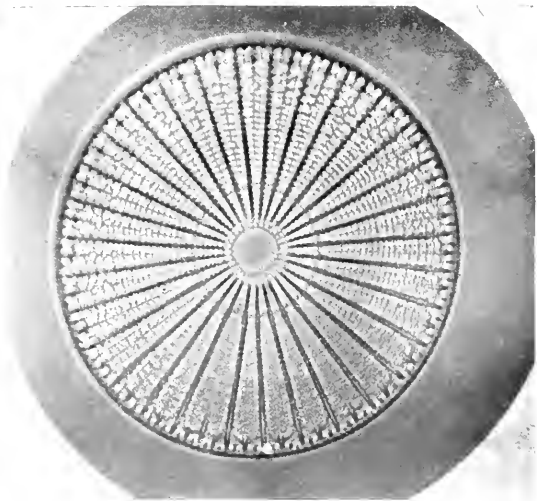

DIATOM. ARACHNODISCUS INDICUS (x 170 DIA.).

be exaggerated by the camera and will quite spoil the effect of an otherwise successful portrait. It is difficult to formulate any rules on this subject. Much will be learned by the observation and comparison of good photographs, paintings,

haps even be practicable to make the exposure without his or her knowledge. At the most, only a few gentle touches here and there, or a word or two of direction, should be necessary. The old style of anxiously arranging and rearranging the model till both parties are thoroughly weary of the whole thing is now entirely abandoned by all the best workers.

POSING CHAIRS AND HEAD RESTS.

For vignette work a good posing chair is a great convenience. A suitable pattern is shown by Fig. 614; this has a revolving

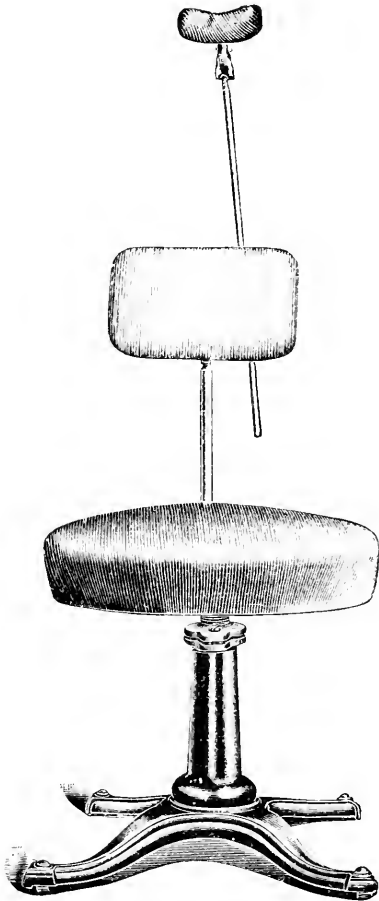

Fig. 614.—THE "WHITE" POSING CHAIR.



Fig. 615.—POSING CHAIR ON REVOLVING PLATFORM.

and engravings. The sitter should on no account be embarrassed and rendered nervous by prolonged "fussing about" and arrangement, as this is certain to lead to a stiff and unnatural result. Whatever is done should be done quickly and without the appearance of deliberation. The sitter may be held in easy conversation till a characteristic and unstudied pose is unconsciously assumed, when it will per-

top like a music stool, and a head-rest is attached to the back. Another ingenious arrangement is shown by Fig. 615, where the entire chair is fixed to a small platform on castors, thus allowing the sitter to be readily turned in any direction without disturbance. For general work the head-rest is now seldom used in high-class modern studios, it being considered inimical to naturalness of pose and expression, besides being quite unnecessary with the rapid exposures now possible. In many cases, however, as with nervous sitters or where the light is not very good, it is obligatory to use a head or body rest if movement is to be avoided. These are obtainable in various designs, a typical example being illustrated by Fig. 616. The sitter should be first arranged as desired, and then the head-rest

carefully adjusted to give just the requisite support, and so that it does not show in the picture.

ARRANGING GROUPS.

A group becomes increasingly difficult to photograph in exact proportion to the

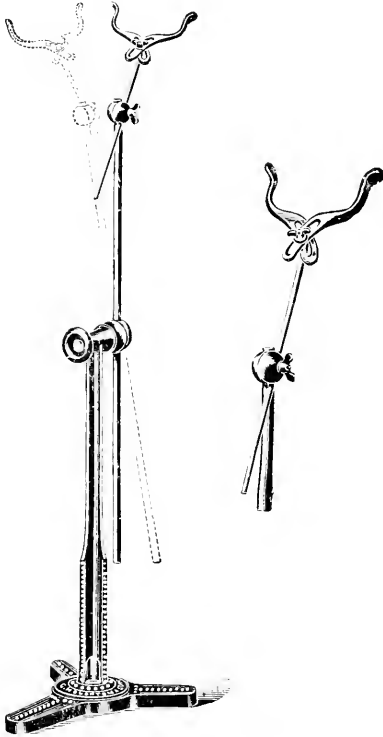

Fig. 616.—ADJUSTABLE HEAD REST.

number of figures in it, owing to the greater risk of movement and the care required to secure a uniformly satisfactory arrangement and posing. A pyramidal composition will generally give the best effect; a merely symmetrical disposition of the figures should be avoided, particularly the monotony and regularity produced by having the faces in a series of horizontal lines. Do not have all the members of the party looking straight toward the lens, but endeavour to secure as easy and unconstrained a grouping as possible. The lighting should be from

the front, but rather towards one side, or the effect will be flat and lacking in relief. Large groups are best done outdoors. A lens of large aperture should be used, and the exposure must be short. Care should, however, be taken not to under-expose. A certain amount of stopping-down will probably be found necessary to get all the figures in focus.

CHILDREN AND ANIMALS.

Animals and very young children are perhaps the most troublesome models the photographer will have to deal with, and both require about the same amount of coaxing and humouring. As regards the first, these will only be dealt with here where the subject properly touches on studio work; the larger aspect of successful photographic work in this direction will be found fully treated in the chapter on Natural History Photography. Briefly, then, a somewhat larger plate should be used than the size required, since one cannot rely on the subject keeping in the same place, and the exposure should be made instantaneously, as soon as the animal has been persuaded to assume a satisfactory position and expression. It is difficult to know if the picture is in focus, owing to the constant movement of the subject, and a twin-lens camera is certainly a great convenience. A new attachment for studio cameras has lately been introduced by Dallmeyer, by means of which the plate may be exposed within a fraction of a second after focussing (see Fig. 617). The dark-slide is placed in position and the image focussed in the ordinary way. At any suitable moment the whole of the frame is pushed as far as it will go to the right, and the rubber ball pressed. These two simple and rapid movements displace the screen, open the dark-slide, bring the plate into position, and make the exposure. This is obviously an ideal arrangement for photographing animals or children, or indeed for all descriptions of studio work; it can be fitted to any camera. Children must be interested or amused, and in some way caused to forget that anything unusual is

going on. A rapid exposure must then be made at a favourable moment.

LINES.

Straight lines in the picture should be avoided as much as possible or broken up by the introduction of other lines or objects: as, for example, the stiffness of a square window would be modified by

may be latent, and capable of development by suitable study or instruction. If the photographer has not already some knowledge of drawing and of light and shade, these should certainly be acquired as soon as possible. Standard works on art and magazines dealing with that subject should be intelligently read, until it is seen and understood why certain poses, lightings, and expressions are beautiful

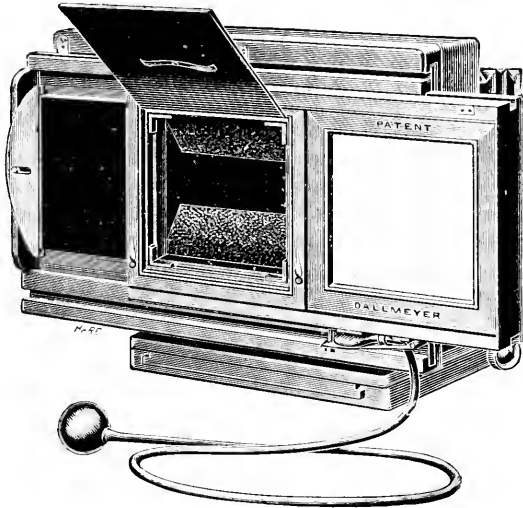

Fig. 617.—THE DALLMEYER CABINET ATTACHMENT.

the curved lines of curtains. It is, however, sometimes permissible to use straight lines by way of contrast to a superabundance of curves, which are thus set off and shown in greater beauty. Do not allow the dress of the sitter to hang in straight lines, but endeavour to secure everywhere roundness and curves. If possible, see that the main lines of the picture lead up to, and serve to point out, the chief feature of interest; that is to say, the figure or the face.

NECESSITY FOR NATURAL TASTE.

The importance of good taste and artistic feeling in portraiture has already been insisted on as absolutely indispensable, if good work is to be done. To a great extent, however, these qualities

and pleasing, while others are the reverse, and the principles which underlie those ascertained facts. There are, however, various rules which may here be given as likely to be of service to the photographer, while not absolving him from the obligation of pursuing the subject further, in the manner suggested. If these rules are carefully studied, the operator will hardly be guilty of any flagrant violation of taste.

BALANCE.

A number of lines should not be allowed to run in one direction, unless balanced by others going in a contrary direction. A good example of this may be given for the sake of illustration in the seated figure of Britannia on the copper coinage. By referring to the outline sketch (Fig. 618), it will be seen that the lines of the figure

alone, from A to B, would distinctly convey a feeling of one-sidedness if not balanced by the opposing line of the trident, and the lines of the shield and right arm. Objects may balance each other as well as lines. In Fig. 619 it will be seen that the gentleman seated in the armchair forms a badly-balanced picture, which fault, however, could easily be remedied by the introduction of a footstool behind the figure: in which case, not only the lines of the latter, but the object itself, taken without reference to its lines, would serve to complete the composition. Masses of light or shade must also be



Fig. 618.—EXAMPLE OF SATISFACTORY BALANCE.

properly balanced or opposed. As the light attracts more attention than the shadow, it follows that a small brightly-lit patch will balance a large dark one. It is important, however, that the attempt to secure perfect balance in the lines of the picture should not be evident or conspicuous, nor should the arrangement by any means be exactly symmetrical and even, so that two opposite sides of the picture closely resemble each other as regards their lines, or light and shade.

COMPOSITION.

The correct and pleasing arrangement of a picture, so that its lines are well balanced, its masses of light and shade suitably opposed, and a harmonious and broad effect secured, is known as "good composition." Breadth is the opposite

of "spottiness," by which is meant the presence of a number of distracting lights or petty details which destroy the unity and repose of the picture. A careful study of "chiaroscuro," or light and shade, is highly essential to the portrait photographer, not only because the camera is at present practically limited to obtaining its effects in monochrome, and so owes the chief beauty of its results to skilfully managed contrast of light and shade, but because the whole expression and artistic success of a portrait depend perhaps more on the lighting than on any other factor. The pose of the sitter



Fig. 619.—ILLUSTRATION OF FAULTY BALANCE.

should be such that the lines of the figure not only balance each other, but are in harmony with those of the background and accessories. The pyramidal form of arrangement will generally prove the most effective, or a composition made up of a series of irregular pyramids or triangles, each balancing and supporting the other. It is of service, however, to remember that, in matters of taste, rules are not always to be rigidly followed, but that a deviation from strict principle is often allowable where the final result is seen to justify it.

THE POSITION OF THE CAMERA.

Besides the power of modifying and altering the lighting by means of blinds and reflectors, or by moving the sitter, a great amount of variety is secured by changing

the position of the camera, although, of course, for certain effects, the best place for this is definitely settled. If the construction of the studio allows, the camera may be worked from either end, which will enable a large number of different lightings to be obtained. There should also be sufficient room for operating sideways, when Rembrandt and similar effects are desired. The so-called Rembrandt portrait, it may be explained, is secured by allowing only the profile to be brightly lighted, while the other three-quarters of the face are in shadow. As a rule, the best way of doing this is to work across the studio, blocking out the light from the front of and above the head, leaving simply a comparatively small source of light coming from behind, in such a manner that only the profile is lit, as described.

TYPES OF FIGURE AND METHODS OF POSING.

Rules have already been given for the special treatment of different types of face, but the various descriptions and peculiarities of figure call equally for distinction of management and posing. A useful hint to remember is that the sitter's height will appear greater or lesser according to the amount of space allowed over the head in the picture. Thus short people may be made to look taller, and those who are excessively tall and thin may have their apparent height decreased by simply altering their position on the plate. Stout people should not as a rule be taken sitting down, especially if they are short also, and it may be noted that a stout figure will commonly show to better advantage sideways than exactly fronting the camera. Unless the whole figure of the sitter is good, a full-length should not be attempted; half or three-quarter length will probably be more successful. Bony and angular persons are always troublesome, but an attempt should be made to secure a pose in which the abrupt corners and projections appear less obtrusive. A short neck may be made less conspicuous by slightly raising the head. Particular care should be taken

with the arrangement of the hands, unless they are clumsy and ungraceful, in which case the loss that is seen of them the better.

SPECIAL FEATURES OF OUTDOOR PORTRAITURE.

As stated at the commencement of this chapter, the main principles of portraiture are similar, under whatever circumstances the work is done. In taking outdoor portraits, however, there are several new factors to be taken into account. The light is much less under control, for one thing, and suitable choice of position is important. As a rule, a spot should be selected away from the sun, but with a stronger light on one side than the other. It is often difficult to avoid heavy shadows under the eyes, caused by excessive top light; the use of a head-screen will, however, prove an efficient remedy. A light frame covered with white or green muslin, or the same material nailed on a couple of laths and temporarily held over the sitter's head by an assistant, is all that is required. If it is not convenient to fix up a proper background, care should be taken that the figure is not placed in front of anything "spotty" or distracting, and particularly that the head does not come against straight lines or other incongruous features.

PORTABLE CANVAS STUDIO.

A convenient form of open-air studio constructed in canvas is shown by Fig. 620. To make it, about 150 ft. of wood strips will be required, about 1 in. square. With these, three frames made as shown (Fig. 621, A, B, C)—two 5 ft. by 8 ft. and one 8 ft. by 6 ft. These are hinged together as in Fig. 621, the larger one being in the centre. From D D to E E there run two cords tightly stretched; after being bound round large screws at D D and E E, the cords are pegged down into the ground at F and G. The centre B is covered with a plain light background, preferably graduated, for head vignettes or three-quarter lengths. The squares I and J are covered with canvas, whilst K and L are each fitted

with a blind of blue muslin, which pulls up from the bottom. Across the two ends are suspended two curtains, either of which, when pulled out, will cover the top of the studio from side to side. These, fitted with large rings, should run

the north. The side-flaps should run in towards the camera. The whole studio folds up like a three-fold screen.

FITTING GREENHOUSE AS STUDIO.

A greenhouse is often found suitable for use as a studio if there is some means of controlling the light. This may be done as follows: Two sets of blinds *A* and *B*, running one under the other, as shown in Fig. 622, are fixed. Both blinds are on spring rollers, so that the blinds run up of themselves when released. The blind *A* is of green lining, and the blind *B* of ordinary white calico. The blinds should be about 2 ft. wide, and fitted so as to overlap and prevent the sun striking in between them. The blinds pull down to the eaves only. Along the sides loose curtains *C* of a dark green colour should be suspended on a

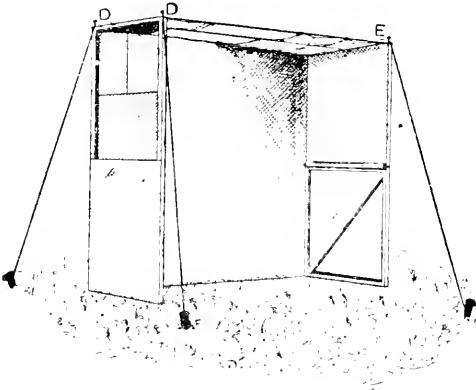

Fig. 620.—PORTABLE OUTDOOR STUDIO.

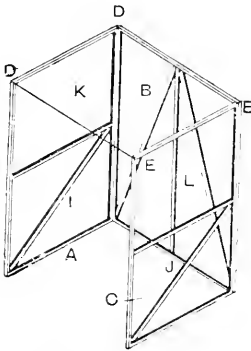

Fig. 621.—FRAMEWORK OF PORTABLE STUDIO.

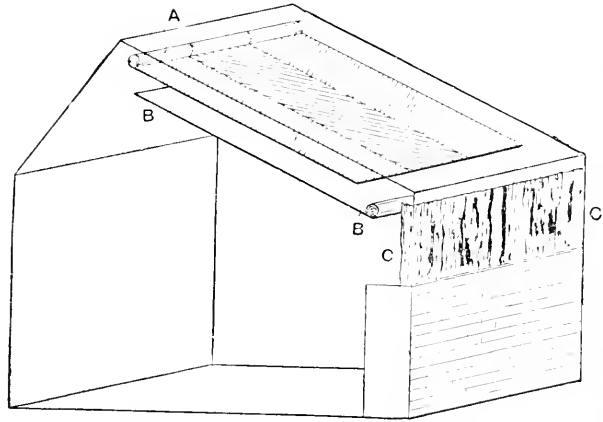

Fig. 622.—GREENHOUSE ADAPTED AS STUDIO.

along very easily. They should be made of some fairly opaque blue material. By their use the principal light can be made to come from any point, and the opening between them should be wedge-shaped, as a rule, with the larger opening in front. Underneath these, if there is a very strong top light, may come a second set of white muslin, fixed in the same manner. A third cord should go across the middle to prevent the curtain bagging down in the centre. The studio should be erected in subdued light, and the sitter should face

wire. As a rule, these curtains will not be used, as, in the case of ordinary pictures, the light proceeding in this direction will have little effect in altering the modelling. Much will depend, however, on the surroundings of the studio and the amount of light transmitted by these side windows. If the windows face a dark lawn or building, the light will be little; but if the windows open to the sky or a whitewashed wall, more top light can be used. Where Rembrandt effects (see p. 487) are desired, these windows will be

very useful. For ordinary lighting, push the windows open to, say, 3 ft. from the background ends, draw down to the eaves the top blind nearest the background, the next blind a foot or so less, and the next less, and so on as required. Then soften down the modelling in the same manner with the blind B as taste may suggest.

PORTRAITURE IN ORDINARY ROOMS.

An ordinary well-lighted room can be made to serve as a studio. For instance, Fig. 623 shows the interior of such a room,

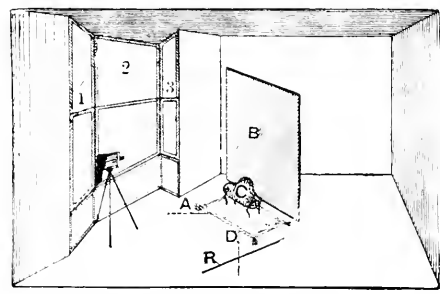

Fig. 623.—ORDINARY ROOM USED AS STUDIO.

16 ft. across, with an 8-ft. bow window. By working across in the manner shown excellent effects may be obtained. If the face requires less contrast, lower blind marked 3 half-way, No. 2 less, and No. 1 slightly. The principle upon which to work is as follows: Suppose the centre of the camera to be the centre of an imaginary arc drawn from the window inwards, on which line the model is placed; as the sitter leaves the window the light becomes gradually softer, until when nearly opposite the centre of the window the lighting will be flat. Many different kinds of framework have been suggested, but none can be recommended, because as much light as possible is required, and even then it is necessary to use the most rapid plates and a portrait lens working at a large

aperture. It will be seen that the confined space will permit of little more than the head and shoulders being taken without using a short-focus lens. c is a lounge for sitter; B, background; R, ground line of white reflector. By placing the model upon the dotted line A, and camera almost to R, excellent Rembrandt effects are secured. The reflector in this case now moves to dotted line D.

STUDIO CAMERAS AND APPARATUS.

Studio cameras, stands, etc., are fully

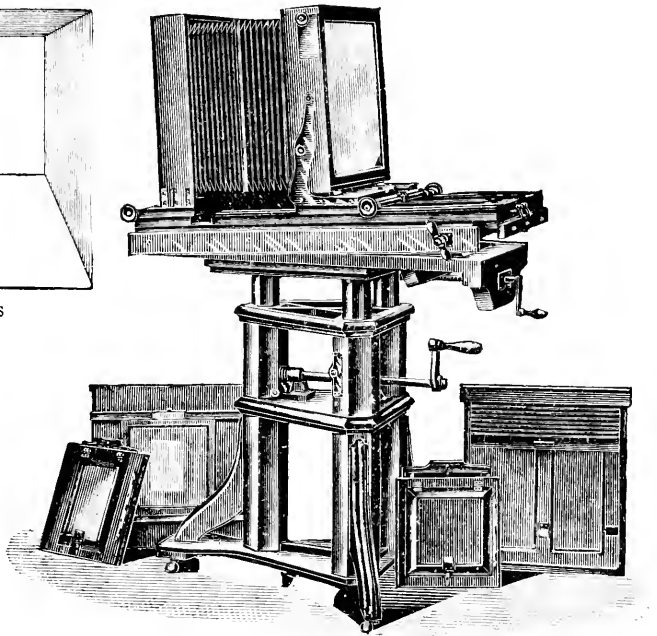

Fig. 624.—STUDIO CAMERA AND STAND.

dealt with in the section on Cameras and Accessories (see pp. 36 to 38 and 51 to 53). Another excellent pattern may, however, be illustrated by Fig. 624. Here will be noted very complete arrangements for raising, lowering, and tilting the camera with the minimum of trouble and exertion, while below are shown the various backs provided to enable plates of different sizes to be used. Fig. 625 shows a stand specially adapted for large and heavy apparatus. What is known as a "repeating

back" is a great convenience, enabling several small-size pictures to be obtained on one plate. Most studio cameras are now provided with this to the extent of allowing half and quarter-plate photographs to be taken on a whole plate. An ingenious fitting, applicable to any camera, has lately been introduced, by means of which a number of midget or postage-stamp pictures may be taken on quarter plates (see Fig. 626). The illustration shows the back inserted in the sliding frame with the focussing screen in position for the first picture. For exposure, the screen is drawn to the left till it meets the stop *H*, the shutter of the dark-slide *B* being held by the bolt *D*, and thus withdrawn by the act of pulling the slide forward. The exposure is made on the top left hand corner of the plate, the number being automatically registered on the indicator *J*. Returning the focussing screen to position actuates a simple

CONCLUDING REMARKS.

The section on Cameras and Accessories contains, in addition to full information on apparatus, shutters, etc., detailed in-

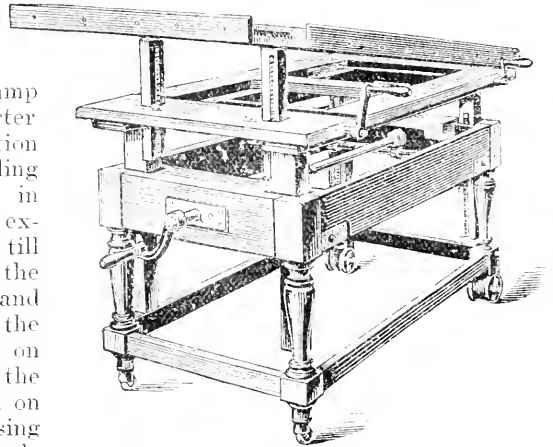

Fig. 625.—STAND FOR LARGE AND HEAVY CAMERAS.

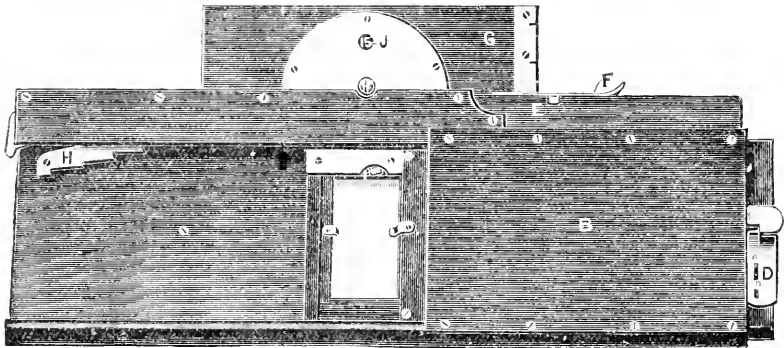

Fig. 626.—FIDLER'S REPEATING BACK.

mechanical arrangement, which will stop the screen on its second journey forward in just the right place for the next exposure, and so on. When one row of pictures are taken, the horizontal sliding frame requires to be moved upwards in the vertical sliding frame *G*, until the catch *F* engages in another notch as at *E*; another row of pictures can then be taken.

structions for making a studio camera. The section on Lenses should be consulted for all particulars relative to those required for portraiture. It may be suggested, finally, that this branch of work should not be attempted until some progress has been made in other and simpler directions, or disappointment and failure are tolerably certain.

LANDSCAPE PHOTOGRAPHY.

INTRODUCTORY REMARKS.

It is safe to assert that landscape work is the branch of photography most in favour with amateurs. That this should be so is readily understood, for not only is it distinctly the easiest, but without doubt it is in this direction that the most beautiful and effective results may be obtained with the smallest degree of trouble and the minimum of experience. The greater portion of what are known as

for selection and arrangement, are well-nigh indispensable.

APPARATUS.

Suitable apparatus will be found described and illustrated in the Section on Cameras and Accessories. Nothing therefore, need be said further, beyond the obvious remark that portability and lightness are especially advisable, so long as rigidity is not sacrificed. The method

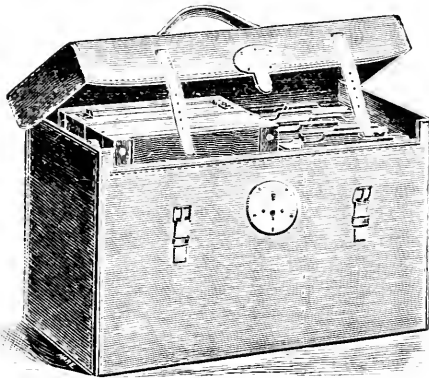

Fig. 627.—CAMERA CARRYING CASE.

“pictorial” photographs are landscapes, although, of course, by no means to the exclusion of other subjects. This is accounted for by the larger amount of control possible, and the wider choice open to the landscape worker, as compared with those available elsewhere. It must not be thought, however, that high-class work of this description, especially of an artistic and thoughtful character, can be accomplished without considerable practice and much careful study. A certain amount of good taste, and a critical eye



Fig. 628.—BAG OR SATCHEL WITH STRAP.

of carrying should receive proper attention if comfort is to be studied. Some prefer a case of the kind shown by Fig. 627, which is held in the hand; others, probably the majority, use a bag or satchel slung across the shoulders by a strap (see Fig. 628). A method much recommended as practical and comfortable is to hasten the satchel to the shoulders by means of short straps passing under the armpits, and provided with hooks to grip eyes attached to the satchel. It must be admitted, however, that, when this manner of carriage is adopted, the apparatus is scarcely so readily accessible as by the other methods described. The tripod.

which should be capable of folding, is generally strapped to the satchel. Although much excellent work is done with the hand-camera, a stand is perhaps more suitable for all-round practice—at any rate, till a certain degree of expertness is attained. The hand-camera will, however, be duly considered presently, when a detailed and comprehensive summary of the various patterns in use will be given.

CHOICE OF POSITION.

Before setting up the camera a careful survey should be made to ascertain the best point of view. It is, indeed, better if a preliminary excursion can be made to the locality for the purpose of noting suitable subjects, and good standpoints from which to take them, before the camera is actually brought into play. The subject being selected and the apparatus set up, the image on the focussing screen is examined to see that all is properly placed. If the principal object is found to be too much to one side, the tripod or turntable screw must be loosened, and the camera revolved till the picture is satisfactorily arranged. If too much foreground is shown on the screen, raise the lens; if too little, lower it, or, if necessary, shorten the legs of the tripod. Do not hesitate to move the whole apparatus nearer or further back, or more to one side, if it is thought that the picture will be improved by so doing. The position for the camera should be chosen with regard to the direction from which the light is seen to proceed. If the sun is immediately behind the operator, the resulting picture will be objectionably flat and lacking in relief; if it is directly in front the view will contain nothing but shadow. It is a common mistake, also, to work with the sun's rays at right angles to the direction of the camera. The condition of things to be aimed at, if possible, is a kind of slanting light, the sun being behind the operator to right or left, or on the right or left hand in front of the camera. In the latter case, care must be taken to shield direct light from the lens. When speaking of the sun, it is not necessarily intended that work should

only be done in bright sunlight, since this is not, as a rule, advisable, but only that the direction of the luminary should be known. A good diffused light is much to be preferred in most cases.

TIME.

It is impossible to lay down any rule as to the best time for landscape work, except that, obviously, due regard should be had to that period of the day in which the subject is most effectively lit. The direction of the sun at any given hour may be readily ascertained as follows:—Hold a watch in a horizontal position with the hour hand facing the sun. Half-way between that point and the twelve on the dial is due south, counting forward in the morning and backward in the afternoon. For example, at 2 p.m., if the hour hand points to the sun, the figure 1, midway between the hour hand and the twelve, points to the south. This being known, the other cardinal points are readily obtained, the north being exactly opposite the south, while the east and west are, of course, midway, on the left and right respectively. If it be required to know at what time the light will proceed from a given quarter, this also may be found by the aid of the watch.

FINDING TIME FOR BEST LIGHTING.

Suppose, for example, it is wished to ascertain when the sun will be in the south-west, the time of making the experiment being, say, 10 a.m. Point the hour hand of the watch to the sun, and midway between the hour and the twelve, that is to say, facing the eleven, will be the south. Looking upon the watch as a compass, the north is opposite the five, the east is represented by the eight, and the west by the two. The south-west, therefore, will be midway between the eleven and the two, or at twelve and a half. But this only gives the position of the south-west: it is required to know at what hour the sun will be in that direction. To find this a simple rule must first be committed to memory, namely, that the hour hand goes twice round the watch

in the same time that the earth makes one revolution; or, in other words, the hour hand of the watch moves at just double the rate of the apparent motion of the sun. The application of this is as follows:—The south, in the experiment just made, is represented by the eleven and the south-west by twelve and a half, the distance between these points being, on the watch, $1\frac{1}{2}$ hours. Now, it is a well-known fact that the sun is in the south at 12 noon. Taking, therefore, 12 noon as the starting point, and adding to this twice $1\frac{1}{2}$, *i.e.* 3—because, as just explained, the sun moves twice as slowly as the watch—it is readily found that at 3 p.m. the sun will be in the south-west. This useful method of calculation is, however, only approximate, and must be employed with due regard to the time of year and the period of sunrise and sunset; for it is evident that if it is calculated that the sun will be in the east at, say, 6 a.m., while it does not actually rise until 8 a.m., the reckoning will prove misleading and disappointing. A special compass is now obtainable, which shows at a glance at what time the sun will be in any given quarter.

VIEW METERS.

In order to avoid unnecessarily setting up the camera to see if a given standpoint is suitable, a view meter should be used. Several forms are available, perhaps the simplest being a rectangular wire frame, the size of the plate employed, to one side of which is fastened a cord of a length equal to the focus of the lens. In use, the wire frame is held in front of the eye at the distance indicated by the cord, when the amount of view included within the rectangle at once shows what would be visible on the ground glass of the camera, if set up at the same spot. If lenses of different focus are used, it is possible to mark their various lengths on the same cord, by knots or other means, so that the view meter becomes available with any lens. The rectangle of the meter may be smaller than the plate, if desired, provided the length of the cord is reduced in the same proportion.

TAPE MEASURE AS VIEW METER.

Some workers recommend the use of a small pocket tape measure as a view meter. In order to mark this for the purpose, first erect the camera in front of some view with a number of prominent objects whose position is readily noticed, and carefully ascertain which of these are visible at the extreme edges of the ground glass. Then, standing in a line with the camera, hold the tape measure straight out in front, in a horizontal position, with one end between the finger and thumb of the left hand. Now, with the arms fully extended, place the left end of the measure so that it comes against the object seen in the extreme right on the screen, and slide the left-hand finger and thumb towards the other end of the measure, keeping it taut meanwhile, until they come over the object marking the opposite extremity of the view. When this is marked on the measure it is obvious that, in future, if the latter is held straight out before the eyes as before, the amount of view coming between one end and the mark previously made will be the same as that which would be shown on the camera screen. Different lenses may be tested in this way, and, suitable marks being made on the measure, it becomes possible to tell at once which lens will be the best to use on a given view from any settled standpoint.

MONOCHROME VIEW METER.

A difficulty always strongly felt by the beginner is that of making allowance for the very different rendering of a coloured view when reproduced in monochrome. Often the chief charm of a landscape may consist of its harmonious and vivid colouring, and since this is lost in the resulting negative, disappointment is apt to follow. Obviously, therefore, colour must be left out of the reckoning in selecting a suitable subject. A good way of ensuring this is to employ a monochrome view meter, which is made as follows:—Cut a piece of thin brass or other metal to the shape of Fig. 629, and cut also a piece of blue glass to the size of the inner dotted square.

Fix the glass in the frame by turning down the edges A, bend at right angles to the dotted line B, and bend also on the lines C and D to form a clip for the scale. The scale should be made of a strip of hard wood of the size shown in Fig. 630, and it should be attached to the glass and frame, and slide freely, but not too easily. The size of the opening E is immaterial, provided it is in exact proportion to the plate. To set the meter, place the camera so that some easily identified objects fall just within the focussing screen on each side, and, putting the end G (Fig. 630) against the check, move the frame to and fro slowly until the two objects fall just

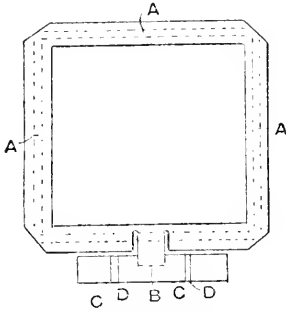

Fig. 629.—SLIDING FRAME FOR VIEW METER.

exactly within the square; a mark is then placed across the strip H. When several lenses are to be used, their angle is found in precisely the same way and the scale is marked with a distinguishing letter, such as W for wide angle, N for narrow, and M for medium. This meter shows, without setting up the camera, whether the view is worth photographing, the amount that may be included, and the lens required. The blue glass reproduces the picture almost in monochrome, and gives a very fair idea of its appearance in a photograph.

VIEW FINDERS.

The terms view meter and view finder were at one time used indiscriminately, but it is now commonly agreed to restrict the latter expression to various devices fixed to the camera in such a manner that the view is seen to be properly arranged

and composed in the finder; this is also the case with the image on the focussing screen of the camera, providing it is in correct focus at the time. These are seldom used on stand cameras except when it is desired to photograph animals or moving objects; in which case it is evidently desirable to know the exact position of the latter on the plate after the slide is drawn. They are, however, practically indispensable for hand-camera work, unless the apparatus is of the reflex or twin-lens variety. The camera-obscura form, in which the image thrown by a small lens is received by an inclined mirror and thrown upward on a ground

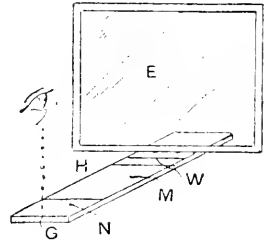

Fig. 630.—MONOCHROME VIEW METER IN USE.

glass screen, is probably the most generally reliable and satisfactory. Owing to the difficulty of recognising the image on the ground glass in full daylight, it is necessary that this description of finder should be either recessed into the camera or provided with a hood. It is true that the hand may be used to shade the ground glass, but it is awkward to do this while at the same time holding the camera and making the exposure. In a modification of the foregoing, the ground glass is replaced by a nearly flat convex lens, which gives a more brilliant image even without the aid of a hood. Fig. 631 shows a convenient pattern of hooded finder for hand-camera and general use. Another, illustrated by Fig. 632, has a revolving screen which indicates the boundaries of both vertical and horizontal pictures. A folding variety (Fig. 633) which can be fixed to either the side or top of the camera, and folds out of the way when not in use, is a favourite with some workers. Other descriptions of

finders, among which are included the bi-concave and the "direct vision," are dealt with in the section on Cameras and Accessories (p. 59).

TESTING THE VIEW FINDER.

Although in the better class of apparatus the accuracy of the finder may commonly be relied upon, it is frequently the case that the field of view included by the finder is smaller or larger than that thrown on the focussing screen. Where this is suspected, the finder should be tested in order that the defect may be remedied or allowed for. In the case of a hand-camera of the ordinary magazine type, open the door at the back and place

greater brilliancy and vigour in the resulting negative are obtainable by their use. There is a good deal of truth in this, and many prominent workers still use slow plates almost exclusively; but it has of late come to be largely acknowledged that a greater softness and delicacy of detail, with a better and more pleasing rendering of atmosphere and tone values, are secured by the employment of rapid plates. Opinion is, however, somewhat divided on this point, and it may be safely stated that, provided the correct exposure is given, thoroughly satisfactory work may be done with either. The best results in landscape photography are unquestionably secured by the use of ortho-

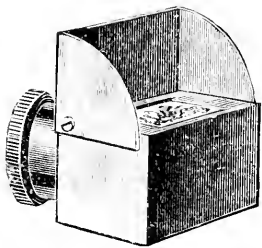

Fig. 631.—HOODED FINDER.

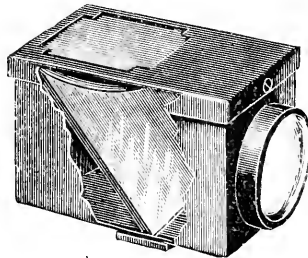

Fig. 632.—FINDER WITH REVOLVING SCREEN.

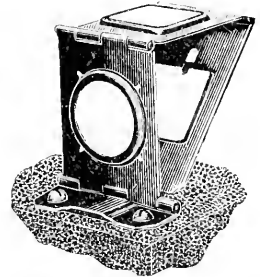

Fig. 633.—FOLDING VIEW FINDER.

a piece of ground glass in the position which would be occupied by the plate. It is then possible, by observing any suitable view or collection of objects, to see whether the amount of image shown on the ground glass exactly tallies with the finder. If it is found to be less, a corresponding margin should be painted out on the screen of the finder with black varnish or other opaque medium; if it is more, the difference should be noticed, and a mental allowance made in future when exposing. If preferred, the test may be made by exposing a plate and leaving the camera undisturbed till it is developed, when the negative may be compared with the finder.

CHOICE OF PLATE.

Slow plates were formerly recommended for landscape work, on the ground that

chromatic plates, in conjunction with a yellow screen. By this means a far more accurate translation of colour values is possible than that given by ordinary plates. This subject will, however, be found fully dealt with in the section on Orthochromatic Photography. It is strongly advised that the plates be backed, otherwise the fine details of tree-tops, etc., against the sky are likely to be lost or detracted from by halation, caused by oblique reflection of light from the back of the plate. With celluloid films halation is largely avoided, and with paper films entirely disappears. The phenomenon of halation and the various methods of avoiding it are referred to with greater detail in the section on Architectural Photography. Other things being equal, there is less chance of halation occurring with thickly coated plates than with those which are thinly coated.

SELECTION OF LENS.

For pictorial work the single landscape lens has much in its favour: its narrowness of angle, length of focus, and absence of biting definition being all good points. The back combination of a doublet lens, such as a rapid rectilinear, is similar in its properties, and may be used in the same manner. For some subjects, the pinhole

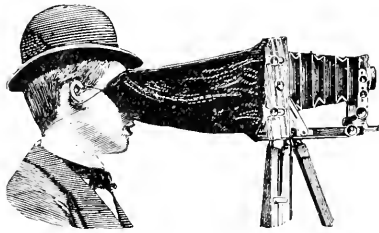

Fig. 634.—THE "PARAGON" FOCUSSER.

is peculiarly suitable, allowing a wide choice as to focal length and angle of view. It is probable, however, that the average worker will prefer a lens which will permit him to obtain the maximum of sharpness when desired, and for technical or commercial landscape photography this is practically indispensable. In this case, the purchase of a good rapid rectilinear or an anastigmat is advised. The greater rapidity of the rectilinear and anastigmat types of lenses must not



Fig. 635.—FIXED FOCUS MAGNIFIER.

be lost sight of, and is obviously an advantage. With lenses of high-grade definition very little stopping-down is advisable for this class of work. A greater amount of brightness and relief, and a better rendering of atmosphere, are obtained by the use of a large aperture. For further information concerning lenses, the reader is referred to the section dealing with that subject.

FOCUSSING.

In all descriptions of outdoor work focussing is apt to prove troublesome if there is any wind, owing to the cloth being blown about. This may be minimised to some extent by sewing cords to

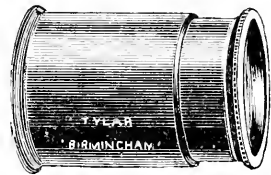

Fig. 636.—ADJUSTABLE FOCUSSING MAGNIFIER.

the cloth, to tie round the lens and across the body. A useful device for simplifying the operation of focussing and rendering a cloth unnecessary is shown by Fig. 634. It consists of a tube or chamber of velvet, arranged to fasten to the camera back while focussing, the other end terminating in a smaller opening just large enough to come over the eyes, and provided with a couple of elastic loops to go over the ears. A focussing glass or magnifier is often of great assistance,

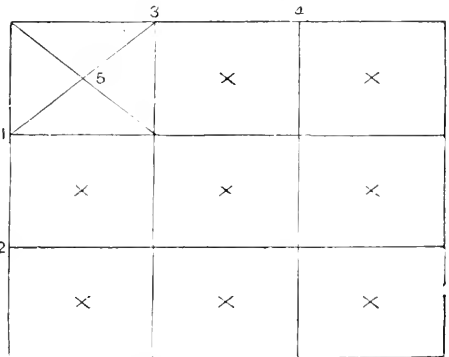

Fig. 637.—COMPOSITION LINES ON FOCUSSING SCREEN.

especially if the light is not very good, or if fine detail is required in certain parts of the picture. Fig. 635 shows a fixed focus pattern of magnifier, and Fig. 636 one with a sliding tube allowing adjustment of focus.

SELECTION AND ARRANGEMENT.

It is a mistake to attempt to include too much in the picture; a small portion of a landscape, treated with discrimination and taste, will be more effective, as a rule, than a wide expanse introducing many opposing and conflicting beauties. But the arrangement of the view should be complete and sufficient in itself, leaving no lurking desire in the mind to see more

ratio to each other, such as 1 to 2, or 2 to 3. For the sake of example, divide each side of the focussing screen into three parts, and connect these divisions by pencilled lines, as in Fig. 637. Then an object placed on any one of these dividing lines, as 1, 2, 3, etc., is favourably situated to attract the eye, while if placed at the junction of any pair of lines it will compel the maximum of attention. If the small rectangles be imagined to be

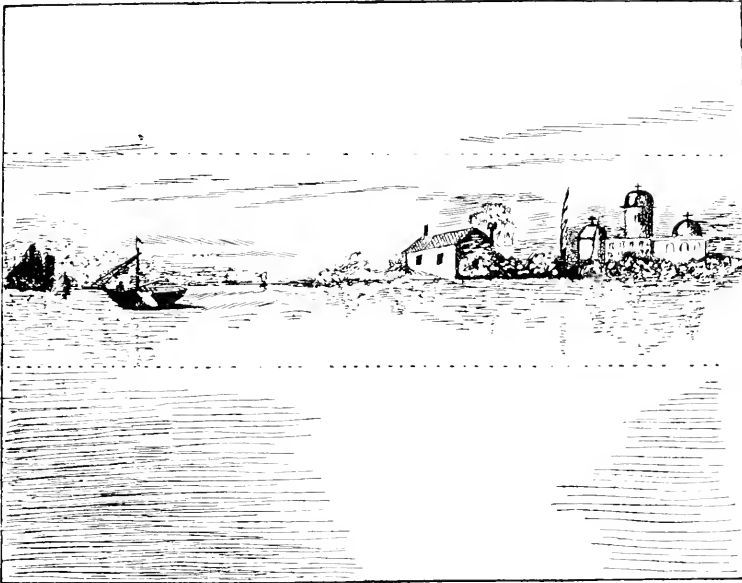

Fig. 638.—PICTURE WITH EXCESSIVE SKY AND FOREGROUND.

than the camera has shown, or the effect will be disappointing. There should be a principal object on which the interest or sentiment of the picture should be, as it were, concentrated, and this should be somewhere near the centre. All objects of secondary interest, not really essential to the composition, should be as far as possible excluded. Experience and observation teach that the relative prominence of different objects is considerably affected by their position in the picture. The least important position is the exact centre of the picture, while the strongest and most effective are generally agreed to be those whose distances from opposite sides of the picture bear some simple

divided by diagonals, as at 5, the intersections of these also are strong points of a minor character, except that in the exact centre of the focussing screen, which, as previously explained, receives less notice than any other point in the picture.

CORRECT PROPORTIONS OF FOREGROUND AND SKY.

Unless in themselves of exceptional interest, the foreground or the sky should not occupy so much space as to detract from the rest of the landscape, in the manner illustrated by Fig. 638, where the interest of the picture is dwarfed into

insignificance by the excessive amount of foreground and sky. This scene should have been made into a long horizontal picture. The height of the camera should receive attention; for as the height of the camera increases, the foreground and the middle distance are extended, and the remainder of the picture is dwarfed by contrast. If, however, the camera is too low, the foreground objects become too assertive and cover other parts of the picture. The proper arrangement of lines and the massing and balance of tones are of great importance, and may to some extent be obtained by a judicious choice of position for the camera. In this matter

eye should be attracted instantly by the brilliancy of this object, which should explain the rest of the picture. In paintings the principal object is not always brilliantly lighted or prominent, but in such cases the object possesses exceptional interest in itself; such, for instance, as something inspiring terror, which it is only necessary to suggest, the details being left to the imagination.

BALANCE.

Where the principal object makes a line at an angle across the picture, some other object running in a contrary direction



Fig. 639.—BALANCE AND ARRANGEMENT OF LINES IN PICTURE.

the photographer is, when compared with the painter, at a great disadvantage. Still, it is surprising what may be done by careful selection of place and time.

COMPOSITION.

It is scarcely possible to give definite rules for picture composition. Given the possession of some artistic feeling, then study of the best examples, constant practice, and the criticism of a true artist on every picture, will in time bring success. If the following hints are studied and acted on, a step will be taken in the right direction. There should be one principal object of interest to which all others are subservient, such as the barges in Fig. 639. As far as possible, let the lines lead to and strengthen the interest of the principal object. The

must be introduced to balance it; without this provision it would have the appearance of instability. Such an example is a boat lying on the seashore, and another boat leaning in the opposite direction, or a figure reclining against the boat. It will be observed that in Fig. 639 the masts and ropes of the two boats balance, and that the horizontal line of the bridge is balanced by the vertical lines of the barges, etc. Where the lines all run in one direction there is a lack of interest and a sense of incompleteness. Firmness and stability are helped by straight lines near the base of the picture. Generally speaking, the principal object should not occupy the exact centre of the picture nor the immediate foreground. Neither the horizon nor any object should completely or noticeably divide it—particularly into equal portions. The lines on



TONGUE OF BLOWFLY (x 50 DIA.).

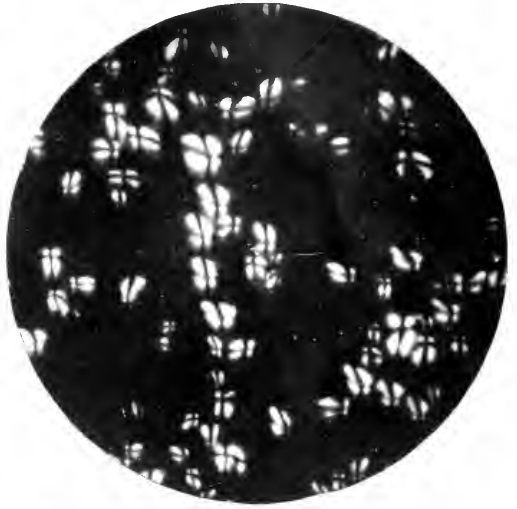

ARROWROOT STARCH (x 170 DIA.).
UNDER POLARISED LIGHT.

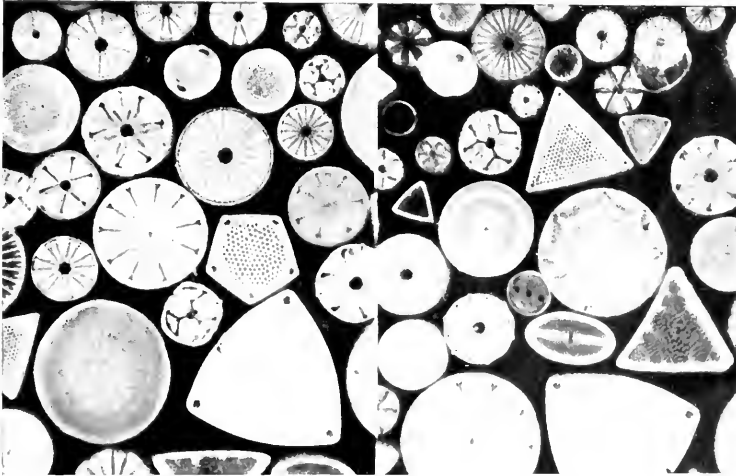

DIATOMS.
DARK-GROUND ILLUMINATION.

the right side of the picture should not be repeated on the left, or, if they are repeated, there should be sufficient variation to destroy any appearance of symmetry.

AVOIDANCE OF MONOTONY.

Bald and monotonous spaces, such as water and sky of an even tint, are particularly displeasing to the eye in a photographic picture, and should be broken up. In the case of water, the smoothness of the surface may be destroyed by throwing in stones, and clouds may be added to a blank sky by combination printing. The horizon line is usually either one-third or two-thirds up the picture; for though, being on a level with the eye, the horizon may come exactly across the centre of the picture, less foreground should be admitted. Straight lines are seldom pleasing, and where a large number of such lines occur it is better to take the picture at an angle.

DIAGONAL AND TRIANGULAR COMPOSITION.

The inspection of any collection of good pictures will demonstrate that, generally speaking, they are built up of wedge-shaped masses. The points of the wedges, it will be noticed, are mostly balanced or supported by wedges running in a contrary direction, or perhaps by a vertical line or mass. A good example of this is afforded by Fig. 640, where the pronounced wedge or triangle formed by the distant mountains is balanced and supported not only by the small opposing wedge in the lower left-hand corner, but by the upright lines of the tree. If the outline of the most important wedge agrees more or less closely with the diagonal of the picture, the composition is said to be diagonal. A much-followed and pleasing arrangement is to allow the principal objects to assume a pyramidal form, or that of a series of pyramids, one supporting the other. These must, however, be irregular in shape, all appearance of geometrical symmetry being carefully avoided. Some further remarks on

composition and balance, which can readily be applied in landscape work, will be found in the section on Portraiture.

LIGHT AND SHADE.

The correct proportion and arrangement of light and shade, or, as it is commonly called, *chiaroscuro*, will have a greater influence on the quality of the resulting photograph than perhaps any other factor. In landscape work, where the lighting is not under the photographer's control, this can only be modified by choice of time and position, or by waiting patiently for the occurrence of any desired and special effect. As a rule, the early morning and evening are to be preferred, since the

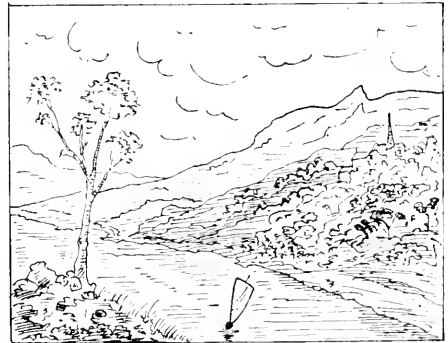

Fig. 640.—BALANCING WEDGE-SHAPED COMPOSITION.

shadows are then longer and the light softer and more harmonious. The principal object should commonly receive the greater amount of light, so that it may first command attention on looking at the picture. It will be noticed that light objects always appear to come forward, and dark ones to recede. There should not be an excessive amount of either light or shade, but masses of one should be balanced by corresponding masses of the other, taking care, however, to avoid any suggestion of symmetry in doing this. The lighting should neither be too concentrated nor too scattered, but focussed in the first place on the principal object, should illuminate the other parts of the picture in well-graduated and suitable proportion.

ATMOSPHERIC PERSPECTIVE.

Most landscapes will be found to contain a foreground, middle distance, and distance; and, if these are carefully examined in the actual view, it will be seen that the lights are brightest and the shadows heaviest in the immediate foreground; that neither the shadows nor the lights are so strong in the middle distance; while, in the distance, all the tones of the picture are soft and subdued. This is the ideal to be sought in making landscape photographs: each plane of the picture should be distinguished from the others by a different depth or tone, and these should be rendered with scrupulous truth as they would be seen in Nature. It is quite possible, and unfortunately very easy, either by bad choice of lighting, unsuitable time, incorrect exposure, or lack of discrimination in printing, to obtain results in which the various planes are altogether falsely rendered. The distance may be too dark, and consequently does not appear distant, the foreground is unduly light, or perhaps there is a disappointing equality of tone and lack of relief about the entire picture. Another point to be insisted on is that not only are distant objects lighter in tone than nearer ones, but there is less distinctness of detail. This, too, should be remembered in taking the negative; the foreground alone should be critically sharp, if even that is necessary, while more or less diffusion of focus should be allowed in the distance. Stopping-down with the object of securing equal definition all over is an obvious mistake in pictorial work. Not only will this gradation of the different planes be present in the landscape, but under favourable circumstances in the clouds also. The nearer clouds will possess more strength of light and shade and greater relief than those which are further off.

CLOUDS.

Although it is sometimes possible to obtain both landscape and clouds on the same negative, it is often necessary, in order to obtain the finest results, either to

take them separately or to print in suitable clouds from another negative exposed at a different time. The method of doing this has been explained elsewhere (see p. 160), so that it only remains to offer some practical instructions on the best procedure for photographing clouds. A very common mistake is to considerably over-expose, thus either getting no result at all, or one that is flat and valueless. A slow plate should be used with the lens stopped down to about $f/45$, and a quick exposure given with the shutter. This, of course, refers to the case of conspicuous and well-lit clouds. Late in the day, or with a dull light, it may be necessary to employ rapid plates. A slightly diluted developer is best, and the negative should be kept rather thin. The use of backed orthochromatic plates with a yellow screen is strongly recommended, when, of course, a longer exposure may be given. A cloud negative should always be softer, and possess less contrast than the landscape. A fact which must not be lost sight of in combination printing is that the nearer and strongly marked clouds are always higher in the heavens than those which are more distant and subdued. Some other important points to which attention must be paid are dealt with on p. 161.

SUNSET AND MOONLIGHT EFFECTS.

Sunset effects are not difficult to reproduce, especially with the orthochromatic plate and screen. In the case of a yellow sunset the screen may be omitted. The sunset should be taken at an early stage, as the light is apt to fall rapidly. Effects which depend mainly on their beauty of colouring are hardly likely to be successful; the subject chosen should be vigorous, and possess sufficient contrast without reference to colour. Exposures will vary remarkably, and it is well to use an actinometer. Photography by moonlight is quite possible, and the exposure is not so long as might be imagined. The subject should be focussed by daylight, and backed plates employed. Many of the so-called moonlight effects seen nowadays are simply considerably under-

exposed daylight views printed very dark. A sea-view or landscape with water is chosen, at a time when the heavens are full of well-defined clouds, and the camera is placed facing the sun, with the lens shaded from direct rays. The opportunity should be awaited when the sun is just behind a cloud, gilding the edges and causing bright reflections on the water; the exposure is then made. The moon may be worked in on the negative if desired. This should be very carefully done on the back, avoiding any tendency to exaggeration.

USEFUL DODGES.

It is often within the power of the photographer, when the lines or arrangement of the picture are not altogether satisfactory, to effect an improvement by cutting off a branch or two, clearing a pathway in the grass, introducing ferns or rushes at suitable spots, and so on. Needless to say, this must not be attempted on private property or enclosed places. Sometimes a high-light on a tree trunk may be emphasised by a little chalk (a pale grey should be used, not white); but this kind of thing requires considerable discretion and artistic taste, or the result will simply be ludicrous. Not infrequently, a little trouble taken over the foreground, by the effective disposition of a few large stones obtained from near at hand, and similar trifling touches, accompanied by the removal of any unnecessary or obstructive feature, will make all the difference between a successful picture and a failure.

INTRODUCTION OF FIGURES.

If done with discrimination, the introduction of figures in a landscape subject will give added interest to the picture. It is so very seldom, however, that figures can be secured which agree in every respect with the sentiment and expression of the landscape, that, in the majority of cases, the latter is best left to tell its own tale. Too commonly, the landscape and the figure or figures are permitted to become rival sources of attraction, till

it is difficult to say whether the picture is intended to represent a figure study with a landscape thrown in, or a well-meant version of natural beauties marred by the intrusion of human beings. The photographer should, therefore, make up his mind as to what is required, and either keep the figures distinctly subordinate to the landscape or make them the principal feature of the picture. Every effort should be made to avoid a constrained appearance on the part of the human subjects. It is a good plan to make a feint of exposing, and then when attention is relaxed, and a natural, unconcerned pose and expression are unconsciously adopted, to give the actual exposure, which, as a rule, should be as rapid as circumstances permit. All incongruity of dress or costume should be carefully guarded against. Suitable figures occurring on a separate negative may often be effectively introduced into a landscape by means of combination printing.

CONVENIENCES FOR TRAVELLING.

The landscape photographer is frequently, when at a distance from home, desirous of some convenient method of changing plates. In such cases, a changing bag, of the type shown by Fig. 641, will prove very useful. As will be seen, the arms are introduced through two sleeve-like openings provided with elastic loops at the ends to exclude light. The dark slide and plates are inserted in the bag, and changing is effected by touch. This is very simple after a little practice, but for those who prefer to see what they are doing the pattern illustrated by Fig. 642 is obtainable. This is supplied with a leather eye-piece fitted with ruby glasses and has a window of ruby medium. Both these changing bags are extremely light, and occupy remarkably little space. Fig. 643 shows a portable developing and changing box, with openings for the head and arms. A compact and practical developing cabinet, fitted with sink, waste-pipe, etc., and well adapted for use in hotels or lodgings, in any room from which the light can be temporarily blocked, is shown by Fig. 644.

Travellers of less luxurious inclination will find a folding triangular lamp of ruby glass of the kind illustrated by Figs. 645 and 646 suitable for any emergencies. It can be conveniently carried in the pocket.

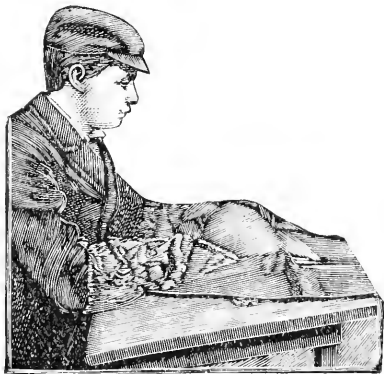

Fig. 641.—CHANGING BAG FOR CHANGING BY TOUCH.

The necessary chemicals should preferably be obtained in tabloid or compressed form. These, with two or three celluloid



Fig. 642.—CHANGING BAG WITH RUBY EYE-PIECES AND WINDOW.

the hand camera, since it is probably in landscape photography, and some closely allied branches, that the latter finds its principal employment. The points to which attention should be chiefly directed

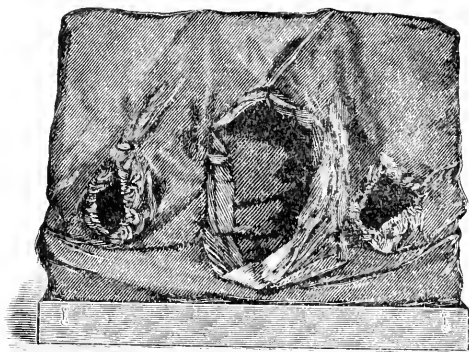

Fig. 643.—PORTABLE DEVELOPING AND CHANGING BOX.

in choosing a hand camera are the rapidity of the lens, the effective working of the shutter, and the clearness and

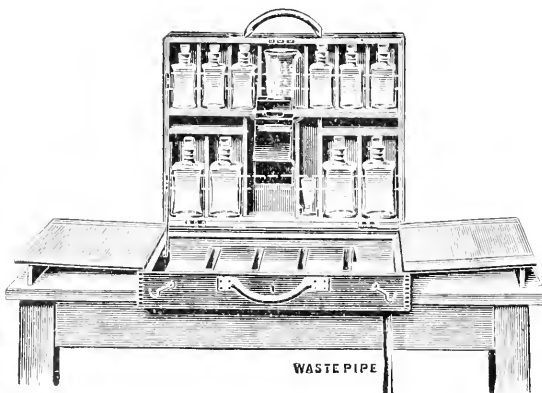

Fig. 644.—TRAVELLING DEVELOPING CABINET.

developing dishes, fitting inside each other, will readily go in a moderately large camera case or satchel, leaving plenty of room for the apparatus itself.

HAND CAMERA WORK.

The present will be a favourable opportunity to consider the special features of

accuracy of the finder or finders. If there is a provision for focussing when required, so much the better; a fixed focus camera is a distinct handicap. The camera should be rested steadily against the body and the breath held while exposing. This cannot well be done for a longer period than about one-eighth, or at most a quarter of a

second, without risk of movement. For exposures of greater duration, the camera should be rested on a stick, or steadied in some other manner. A light, telescopic metal tripod is a useful accessory. It is a defect with many telescopic stands that the top or head is incon-

veniently small, so that rigidity of the camera is difficult to secure. This is obviated in the "Perfecto" tripod (Fig. 647), which has, in addition, an adjustable movement of the head, allowing the camera to be readily clamped in any posi-

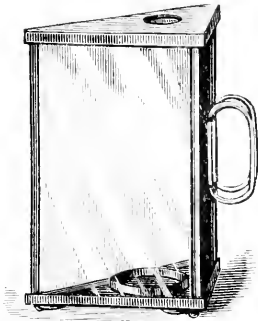

Fig. 645.—PORTABLE TRIANGULAR LAMP (Open).

tion without moving the tripod legs. The latter, which are of triangular section, can be securely adjusted to any height by a clamping device.

use with either dark slides, daylight-loading roll holders, or changing boxes, all of which may be obtained to work interchangeably. It allows of focussing on a

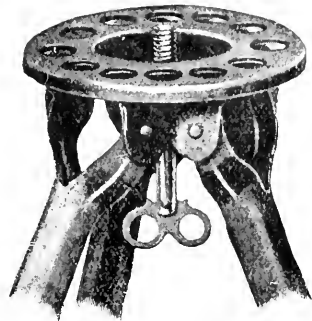

Fig. 647.—"PERFECTO" TRIPOD STAND.

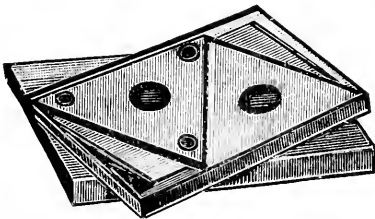

Fig. 646.—PORTABLE TRIANGULAR LAMP (Closed).

tion without moving the tripod legs. The latter, which are of triangular section, can be securely adjusted to any height by a clamping device.

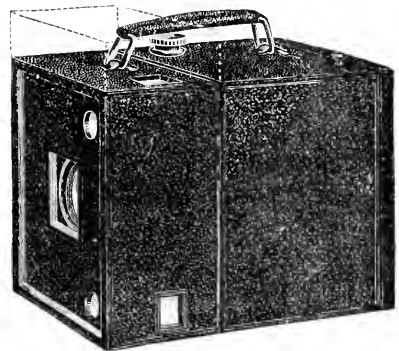

Fig. 648.—ADAMS' "KENI" HAND CAMERA.

hooded ground-glass screen as well as by a scale, and has vertical and horizontal rising fronts. The "Natti," shown open and closed by Figs. 649 and 650 respectively, is a remarkably small and neat folding camera, which will go in the coat pocket. All necessary fittings, including a rising front, are self-contained, and eight plates or fourteen flat films may be carried. An improved form, even more compact, has just been issued under the

SOME STANDARD PATTERNS OF HAND CAMERAS.

It will no doubt prove of service to investigate the construction and arrangement of a few of the chief patterns of hand cameras, as promised in an earlier section. It will readily be understood

appropriate name of the "Nattia." The "Videx" is a splendid example of the camera *de luxe*. As will be seen by the illustration (Fig. 651), it belongs to the reflex type. One of its special features is

THE "FALLOROLL" HAND CAMERA.

This compactly designed instrument deserves special mention. As shown by Fig. 652, it is of the folding type, and

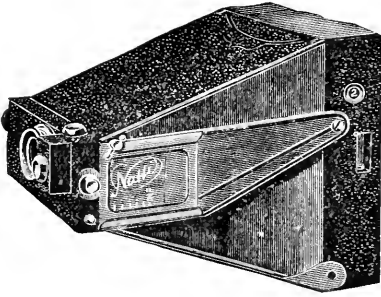

Fig. 649.—"NATTI" HAND CAMERA (Open).



Fig. 650.—"NATTI" HAND CAMERA (Closed).

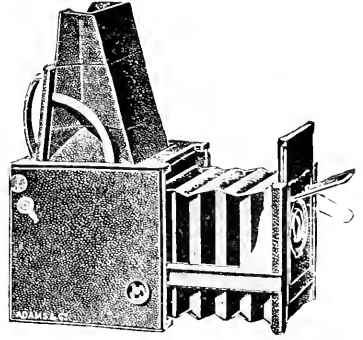

Fig. 651.—ADAMS' "VIDEX" HAND CAMERA.

a revolving back by which the dark-slide may be instantly changed from a hori-

zontal to a vertical position, or *vice versa*, will take either plates or daylight-loading films. By removing the sliding panel at

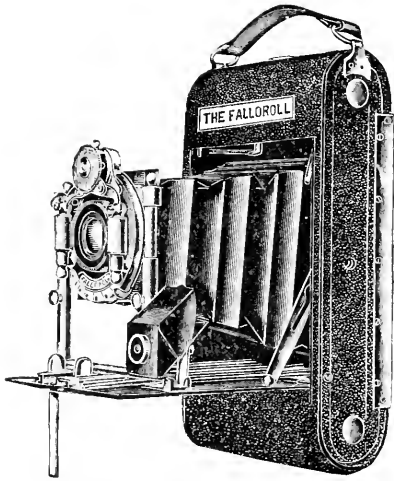

Fig. 652.—"FALLOROLL" HAND CAMERA.

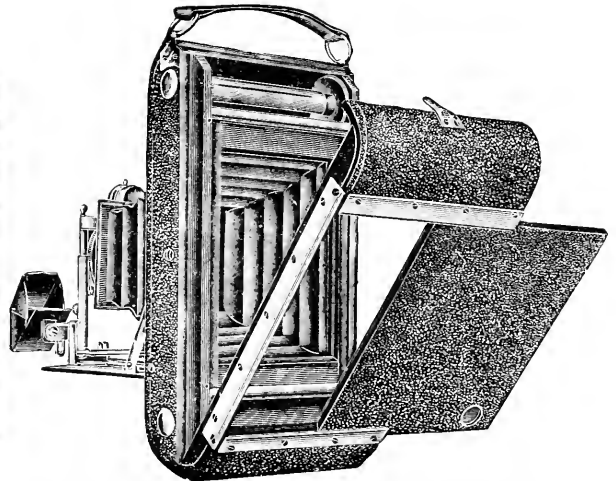

Fig. 653.—BACK VIEW OF "FALLOROLL," SHOWING SLIDING PANEL.

zontal to a vertical position, or *vice versa*, without the necessity of covering the plate. The picture is focussed and seen right up to the moment of exposure, the latter taking place without the slightest vibration.

the back (Fig. 653) a focussing screen or dark slide may be inserted for use with glass plates. The camera is provided with bushes for attachment to a tripod in either a vertical or horizontal position, a focussing scale, reversible hooded brilliant

view finder, and, in fact, practically every modern movement. The lens is an R. R. working at $f.8$ in conjunction with a shutter of the "Unicum" pattern. It can also be obtained with a long extension and a convertible lens, the front and back combination of which may be used separately.

THE FOLDING POCKET "CYKO"

(Fig. 654) is distinguished by being, with the exception of the bellows, entirely of aluminium. It is consequently extremely light, and when closed up is only $\frac{3}{4}$ in.

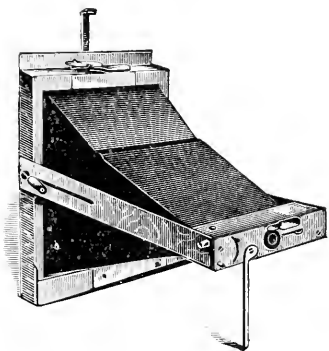

Fig. 654.—FOLDING POCKET "CYKO."

thick. The camera has two finders, a movable diaphragm plate and time and instantaneous shutter; it takes double dark-slides carrying glass plates. The manufacturers (Messrs. J. J. Griffin and Sons, Ltd.) are also well known for many other varieties of folding hand cameras.

THE "AL VISTA" PANORAMIC CAMERA, ETC.

This ingeniously designed instrument (Fig. 655) has a swinging lens, enabling a long, narrow picture, including an angle of about 180° , to be obtained. It is intended for use with daylight-loading roll films, and is arranged for time or instantaneous exposures of different lengths. Besides this, a special attachment is provided allowing long or short photographs to be taken at will. In addition to the above and a large number of hand and other cameras which cannot be specially mentioned, Messrs. Houghton are re-

sponsible for the "British Ensign," an admirable daylight-loading roll film camera, which, besides all the usual adjustments, is fitted with a special focussing scale, the "Cornex," which not only shows the distances at which objects are in focus with the largest stop, but also the range of distance in focus when using any of the smaller stops. It can be obtained, if desired, with a plate attachment and

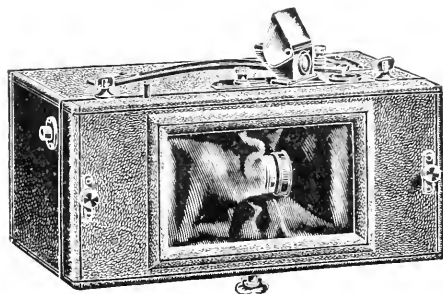

Fig. 655.—"AL VISTA" PANORAMIC CAMERA.

focussing screen, so that it is available for either plates or films. The "Dalo" (Fig. 656) has the unique feature of taking daylight-loading spools of flat cut films, which, as exposed, fall into a special receiver, and can, if necessary, be removed



Fig. 656.—"DALO" HAND CAMERA.

in daylight without disturbing those remaining in the spool! The "Sanderson" hand camera, with its exceptionally high rise of front and other useful adjustments, is peculiarly suited for architectural work.

KODAKS.

The many patterns of hand cameras emanating from Kodak, Ltd., have become

so well known that the name Kodak is frequently used carelessly as a synonym for any hand camera. Typical designs of this make are illustrated by Fig. 29 (p. 26) and Fig. 33 (p. 27). In pursuance of the present intention to mention only those models possessing points of novelty or interest, it will merely be necessary to touch briefly upon the special features of

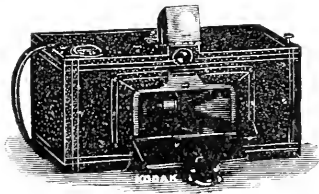

Fig. 657.—"PANORAM" KODAK.

the "Panoram" Kodak (Fig. 657). This instrument, which was awarded the Gold Medal of the Royal Photographic Society, is, as its name indicates, intended for panoramic pictures, possessing an ingeniously arranged swinging lens. It takes

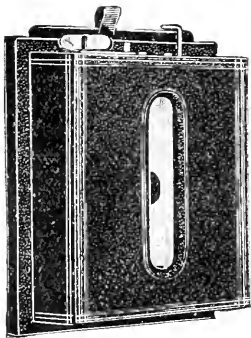

Fig. 658.—CARTRIDGE FILM ROLL HOLDER.

daylight-loading roll films. The Kodak cartridge film roll holder (Fig. 658) can be fitted to an ordinary field camera like a dark slide, and enables daylight-loading films to be used instead of glass plates.

THE NEWMAN AND GUARDIA "REFLEX."

This camera, shown open by Fig. 127 (p. 59), and closed by Fig. 659, embodies the reflex principle of construction in its

best form. It has a silent-working reflector, showing a full-size image of the picture on the finder, which is very successfully screened from direct light: a long extension, double rising front, de-

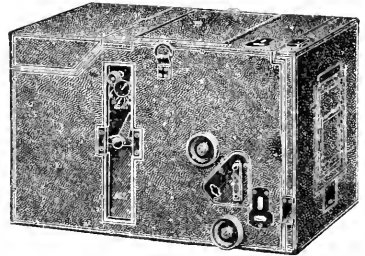

Fig. 659.—NEWMAN AND GUARDIA "REFLEX"
(Closed).

tachable focal plane shutter, and many other good points. Interchangeable roll holders and plate changing boxes are obtainable, so that this camera is available

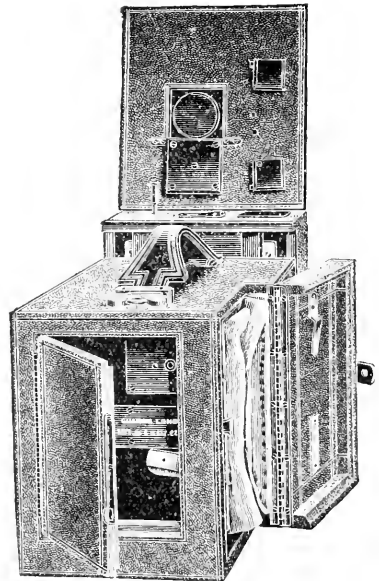

Fig. 660.—"N. AND G. UNIVERSAL," WITH ALL DOORS
OPEN.

for use with practically every kind of sensitive material on the market. Another admirable camera, which is of the

ordinary box form, the "N. and G. Universal," is shown with all doors open and ground glass of focussing screen removed by Fig. 660. The bag, lifter, and lock of the changing box will be noticed at the side, while on the lid of the raised front are seen the automatic spring door, self-capping arrangement, and finder covers. This camera combines almost every imaginable movement, and can also be used, if desired, with interchangeable roll holder or dark-slides. The "N. and G." changing box, which can be adapted to the majority of field and hand cameras, is illustrated by Fig. 37 (p. 29).

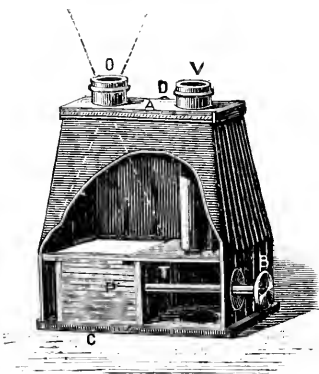

Fig. 661.—BINOCULAR HAND CAMERA.

THE BINOCULAR HAND CAMERA.

This contrivance (Fig. 661) is in outward appearance like a small field glass, and is held up to the eye as though sighting a distant view, but with the lenses pointing outward. At o is placed a rapid rectilinear lens with instantaneous shutter, throwing its image on a magazine of plates p, which may be automatically and quickly changed. The second lens v is a finder or sighting glass, showing the exact size and appearance of the picture at the time of pressing the button. An advantage of this form of camera is that it exactly represents the view seen by the operator. A recent improvement on this is the "Maekenstein" Stereo-panoramic camera, which is instantly adjusted for either stereoscopic or panoramic pictures.

THE VERASCOPE, ETC.

This contrivance, which, as well as the above, is obtainable of The London Stereoscopic Co., is a hand camera taking twelve small stereoscopic or twenty-four single pictures, which may be viewed through the ordinary stereoscope or in the camera

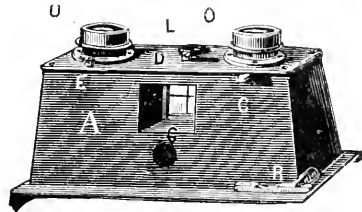

Fig. 662.—CAMERA BODY OF "VERASCOPE."

itself. The apparatus consists of two parts—the camera proper (Fig. 662), and the detachable magazine, shown by Fig. 663. In the first illustration A is the

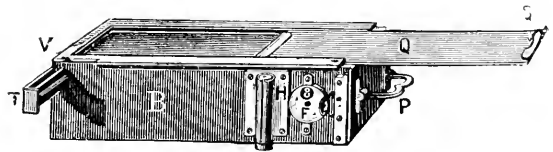

Fig. 663.—MAGAZINE OF "VERASCOPE."

camera body, o o the two lenses, L a single lens throwing an image on the view-finder G, E and C buttons operating the shutter, and R a spring catch locking the magazine to the camera. In Fig. 663, B is the magazine, T a slide covering an aperture v, through which the sheaths are introduced, Q a metal sliding cover which is drawn out on exposing, F an exposure indicator, H a sighting arrangement, and P a handle for withdrawing the magazine from the camera. Watson's Stereoscopic Binocular, another instrument of a somewhat similar description, has the actual lenses fitted at one side, so that pictures may be taken at right angles to the direction in which the field glass is ostensibly pointed. This feature makes it an ideal detective camera. It is available for either stereoscopic views or single pictures.

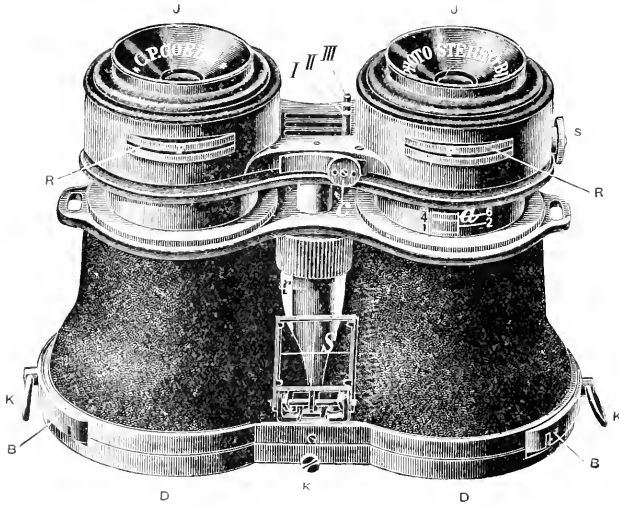

Fig. 664.—GOERZ STEREO BINOCULAR.

THE GOERZ STEREO BINOCULAR.

Fig. 664 is of highly ingenious design. It can be used at will either as an opera glass, field glass, or photographic camera

for single or stereoscopic views. The lenses are the well-known Goerz double anastigmats. The dark-slides are of thin sheet steel, and twenty-four of these are carried in a separate leather wallet a

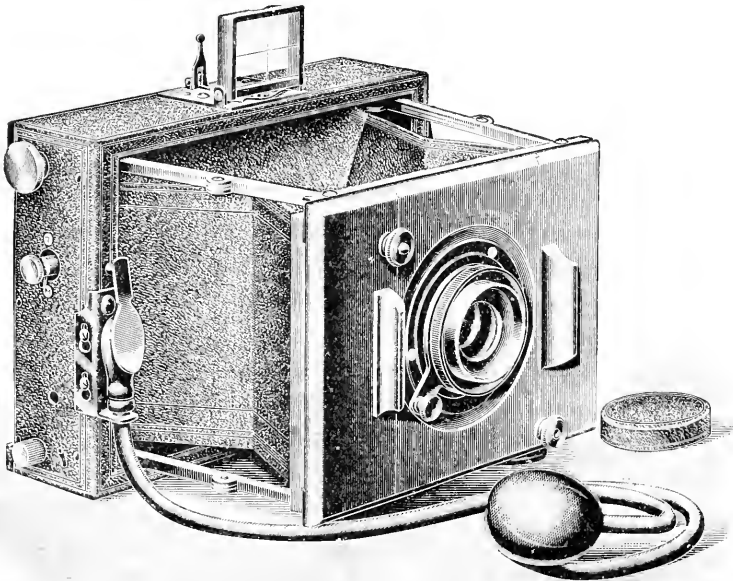

Fig. 665.—VOIGTLÄNDER'S "FAVOURITE" HAND CAMERA.

little thicker than an ordinary letter case. They are placed alternately in the pull out sliding frames *B B* actuated by the rings *K K*. Revolving diaphragms *R R* are provided, and focussing is effected as in an ordinary opera glass by the milled rim *r*. The shutters are worked by press-

ment, the front being held in position by side stay-pieces. The focal-plane shutter allows of exposures as rapid as $\frac{1}{200}$ second, and the width of the slit may be altered from the outside. The lens is provided with a focussing jacket moved by a lever and milled screw, while

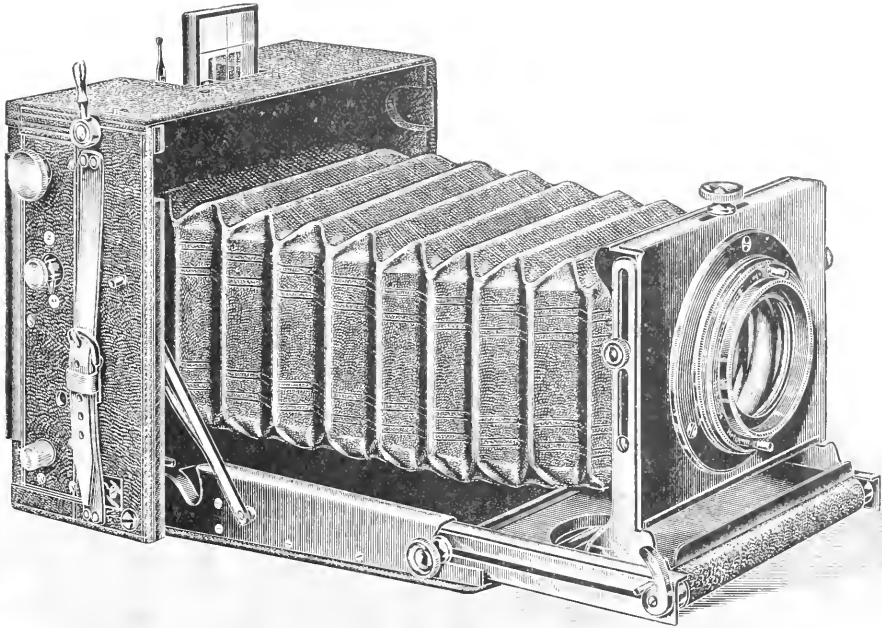

Fig. 666.—VOIGTLÄNDER'S "HELIIAR" HAND CAMERA.

ing the button *c*, the levers *i. ii. iii.* determining whether the first or the second lens, or both together, are exposed. The binocular eyeglasses and camera objectives are placed at *J J*; *s* is a brilliant view finder which folds out of the way when not in use. There are other cleverly contrived movements which cannot be here explained.

VOIGTLÄNDER HAND CAMERAS.

The "Favourite" (Fig. 665) is a typical example of a high class collapsible focal-plane hand camera. As will be noticed, it is closed or extended by a single move-

ment, the camera front possessing rising, falling, and horizontal motions. Double dark-slides are employed with neatly reeded roller shutters. The "Heliar" (Fig. 666) has also a focal plane shutter and the other movements mentioned, but focussing is effected by means of a rack and pinion. It can be fitted either with dark-slides having reeded shutters as previously described, or with the ordinary pattern of dark-slide. The "Brunswick," a convenient pocket camera for either roll films or plates, is shown by Fig. 667. Another camera, the "Universal," permits the use of lenses ranging in foci from $3\frac{1}{2}$ to 12 in.

THE "FRENA."

The various hand cameras of the "Frena" pattern (Messrs. R. and J. Beck), one of which is shown by Fig. 668, have deservedly won a high reputation. They all take forty notched flat films,



Fig. 668.—"FRENA" Box Pattern Hand Camera.

which are placed in the magazine in a pack, just as received from the makers, and, by an ingenious changing system of alternate notches and teeth, are exposed and removed into a receiving chamber

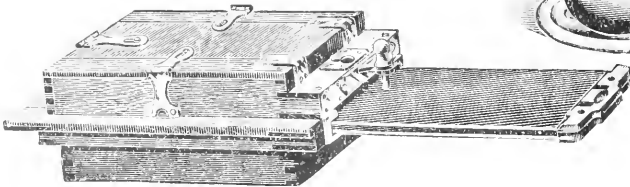

Fig. 669.—"FRENA" Film Holder.

one by one. These cameras can also be obtained to take plates in notched sheaths as well as films. A folding variety is now procurable. The "Frena" film holder (Fig. 639), which can be fitted to any tripod camera like an ordinary dark-slide, carries twenty flat films and changes them automatically as required. It should be stated that this necessitates a readjustment of the focussing screen, or the employment of another having the same register as the film holder. The edges of the magazine are made slightly wider than is necessary, to facilitate fitting.

THE "TELEPHOTO CORNEX," "DAI CORNEX," AND "ZAMBEX."

Beck's "Telephoto Cornex" hand camera is available for use in the ordinary manner, while by means of an instantly adjusted extension, shown open

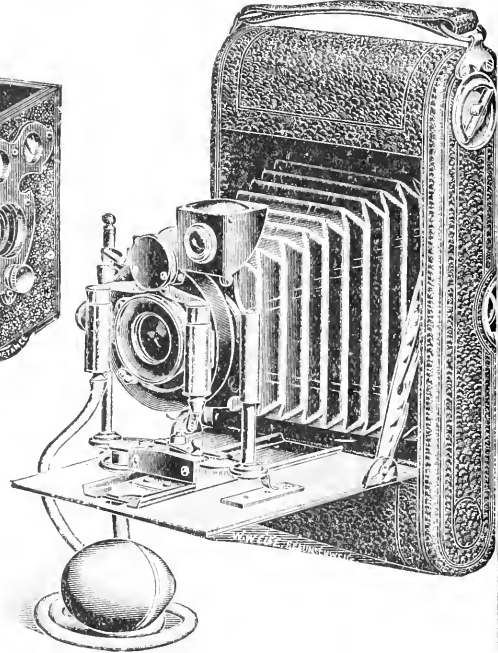

Fig. 667.—VOIGTLÄNDER'S "BRUNSWICK" HAND CAMERA.

by Fig. 670, it can be employed for telephotography. Besides the usual finders, a third one is provided, giving the view included by the telephoto lens. The latter is brought into position by simply pulling a slide after drawing out the extension front. There are two focussing scales, each provided with a "Cornex" Index, giving the depth of focus with any aperture for both lens systems. Another advantage of this camera is that it becomes possible to focus on near objects without using supplementary lenses. The "Dai Cornex" hand camera (Fig. 671) embodies the novel feature of daylight loading with glass plates. The metal

sheaths holding the plates are all provided with a channel or groove which fits the one behind, so that a pile may be exposed to light without risk of fogging the contained plates. A dozen sheaths, with a thirteenth on top to protect the foremost plate, are held together

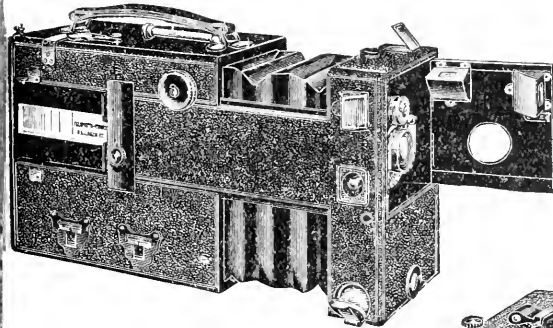

Fig. 670.—“TELEPHOTO-CORNEX” HAND CAMERA.

by an elastic band and placed in the camera. The band is then pulled off, the door closed, and the camera is loaded. The sheaths may be removed in daylight in a similar manner. This camera is obtainable in various patterns, and is supplied with three sets of sheaths. Another ingenious camera, the “Zambex,” takes cut films or plates in a special light-tight envelope containing what is called a “Zambex Skeleton.” The plates or films are changed by opening a door at the back and pulling one of a series of projecting tags.

OTHER HAND CAMERAS.

There are many other excellent makes of hand cameras of which space will not permit more than a casual mention. The “Wizard,” of which the long-focus pattern is shown by Fig. 672, and the “Premo” may be alluded to as respectively handsome and strongly-made instruments of American manufacture. The “Challenge” hand cameras (Lizars’) are all of sound and serviceable construction. The

“Tella” (Tella Camera Co., Ltd.) takes fifty flat films in a pack, which are changed automatically by the simple in-and-out movement of a sliding frame or septum in the base of the camera, the number of exposures being registered by the same action. The “Ilford” carries forty cut films, and has an effective changing arrangement. The Goerz-Anschütz is a folding camera adapted for very rapid work, being fitted with the famous focal-plane shutter designed by Herr Ottomar Anschütz. The Ernemann, Suter, Ross, “Minimum Palms,” “Soho,” “Vril,” and Clement and Gilmer focal plane cameras are all of admittedly high reputation for practical and efficient workmanship.

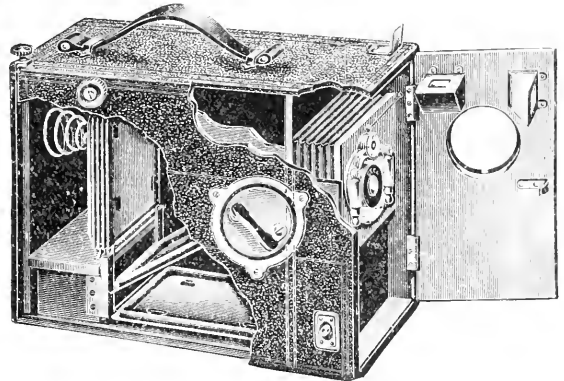

Fig. 671.—“DAI CORNEX.”

The Shew focal plane “Reflector” and the well-known “Xit” cameras enjoy a large measure of popularity. The Thornton-Pickard “Automan” models possess the novel feature of opening out to the infinity focus by simply pressing an outside button. The Busch “Freewheel” cameras, primarily intended for use with roll films, allow the insertion of glass plates in holders in front of the film without the necessity of moving the latter. In addition, there is a winding-back arrangement for the film, so that focussing may be done, if desired, for each exposure, on either plates or films, without disturbing the camera. With the “Miral” Reflex (Talbot and Eamer); the Underwood

"Foldette"; the "Primus," "Carbine," and "Cameo"; the "Teb"; the Lancaster "Filmograph," "Focoplane," "Invincible," and "Planoreflex"; the "Century"; the "Sickle"; and the "Dallmeyer," this notice of the principal makes and descriptions of hand cameras at present obtainable must perforce be closed. An endeavour has been made to make it thoroughly comprehensive, while excluding the cheaper patterns and those which are simply copies of standard designs, possessing no distinctive feature of interest. Those cameras, also, intended

hard effect, for this class of subject presents strong contrasts, a full exposure should be given, especially if there are any dark objects in the foreground. For hoar frost studies, however, which are generally lacking in contrast, a minimum exposure must be given. All these remarks are, of course, equally applicable to work done with the stand camera, which is, indeed, more suitable if the light is poor.

PHOTOGRAPHING MOUNTAINS.

For this class of work a long focus lens should be employed, or distant mountains will appear dwarfed. Such pictures seldom look well in a small size, but should be either taken on large plates or enlarged. Alpine scenery generally gives the best pictures towards the close of the day or early in the morning, when the lighting is softer and the atmospheric effect is better. Isochromatic plates and a screen should be employed. Care should be taken that the camera is level, or the mountains will appear as if falling over. It is, however, sometimes possible to give additional steepness of appearance to mountain scenery by slightly tilting the camera forward. With distant mountains, the sensation of distance may be increased, and their apparent height added to, by the choice of a suitable foreground, to give scale and contrast to the picture.

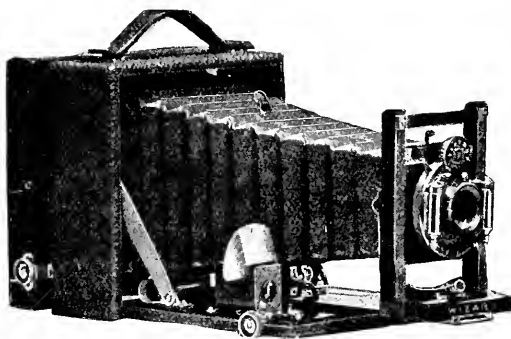

Fig. 672.—LONG FOCUS "WIZARD."

for special work have been omitted, as reference will be made to them elsewhere.

WINTER HAND CAMERA WORK.

Many beautiful subjects are to be secured in the winter—rain and mist effects, hoar frost and snow scenes, all making admirable pictures. A very rapid plate, a lens of large aperture, say $f/6$, and a focal plane shutter are advised, although much good work has been done with an ordinary R.R. lens and outside shutter. With a reflex or twin-lens camera, where the image can be examined for sharpness, an even larger aperture may be advantageously employed. For snow scenes an isochromatic plate and pale yellow screen are recommended, and backed plates should always be used. Needless to say, the snow reflects so much light that the exposure is considerably less than would be required if the former were absent. In order, however, to prevent a

DEVELOPMENT OF LANDSCAPE NEGATIVES.

The object to be kept in view in developing landscape negatives is to secure a thin, soft negative of fine gradation, yet with sufficient density and contrast to give a satisfactory print in the chosen printing process. A slightly diluted developer is, therefore, indicated for the majority of subjects; although, of course, requirements may vary according to the description of subject, the exposure, and the particular effect desired. As to choice of developer, this may pretty safely be left to individual taste; hardly any two workers would agree on the matter. Formulae and methods in great variety, with descriptions of the characteristic

behaviour of each developer, will be found in another section. Printing and the various expedients for doctoring and dodging the negative are also fully treated elsewhere.

CONCLUDING REMARKS.

Perhaps no better advice could be given to the would-be landscape photographer than, even at the very beginning, to specialise. Instead of flying from one subject to another, making practical acquaintance with innumerable different plates, papers, and developers *en route*, let the worker determine, for awhile, not only to adhere to one brand of plate, one

developer, and one printing process, but, a more difficult matter and requiring stern resolution, to one special class of subject. Let this be persevered in until perfect control is secured over the selected materials, and good pictures, showing thought and individuality, are accomplished. Then, and not till then, it will be time to widen the scope of experience and enter fresh fields of work. This is not the advice of the theorist or the sentimentalist, but the matured expression of opinion given by many of the foremost workers in photography, who with quite remarkable unanimity agree that the path to technical perfection lies down the avenue of specialism.

PHOTOMICROGRAPHY.

USES OF PHOTOMICROGRAPHY.

PHOTOMICROGRAPHY, combining the two subjects microscopy and photography, forms an interesting study for anyone, and besides this it is very useful to the medical man, the chemist, the naturalist, the engineer, and probably others. The modern microscope is as far advanced from its prototype as the modern locomotive is from that of Stephenson. The microscope is an instrument of great precision and of extreme utility, because, by means of it, minute structures of all kinds

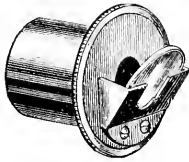

Fig. 673.—ORDINARY CAMERA LUCIDA.

can be rendered apparent, drawn or photographed, and thus kept in the form of permanent records. As the minute structures of various substances are often characteristic, the microscope is one of the most useful instruments of scientific research. The application of photography to the delineation of microscopic objects dates back to the very early days when the camera first came into use, but it is only within the last twenty years that it has taken the place it really deserves, and become something more than a scientific curiosity. Previous to this the magnified images of objects under the microscope were obtained by a species of tracing; some form of reflector or *camera lucida* being placed over the eye-

piece of the microscope, and the image of the object reflected upon a sheet of paper placed on the table.

THE CAMERA LUCIDA & PHOTOGRAPHY.

The contrivance shown by Fig. 673 is the ordinary *camera lucida*, or Beale's neutral tint reflector, consisting of a piece of smoked glass placed at an angle of 45°, while Fig. 674 shows a prism reflector. The magnified image of the object being projected upon a sheet of paper by reflection, it is a comparatively simple matter to pro-

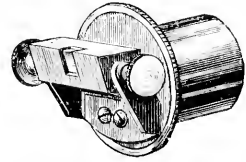
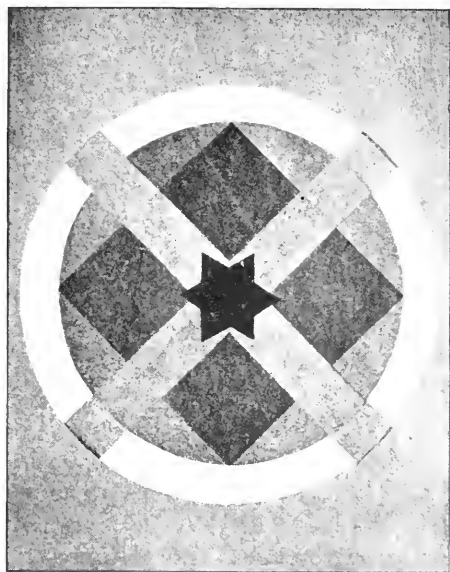
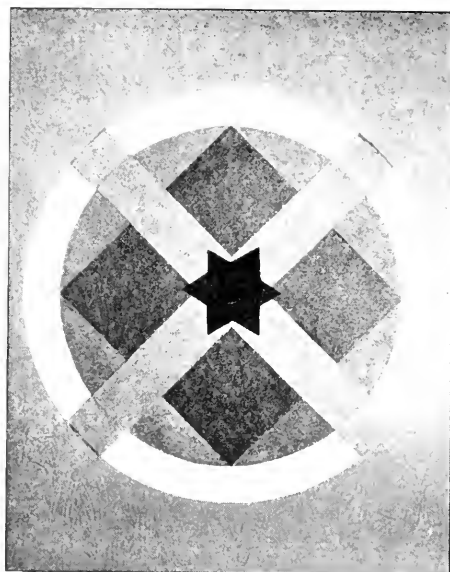

Fig. 674.—CAMERA LUCIDA WITH PRISM REFLECTOR.

duce a drawing or, more correctly speaking, a tracing of it. When, however, the object contains a considerable amount of fine detail, the production of a tracing showing all the detail will be found very difficult and probably impossible, even when a skilled draughtsman is employed; hence, if two drawings be made by different persons they will be more or less different, and neither will represent exactly the original object. The fact is, a certain amount of the detail is left out or modified, and a good deal is due to the personal element introduced. Hence, if drawings of any common object in books on microscopy be compared, it will be found that these drawings are often quite unlike each other, and only to a limited



ORDINARY PLATE . DAYLIGHT.



ORDINARY PLATE : INCANDESCENT GASLIGHT.

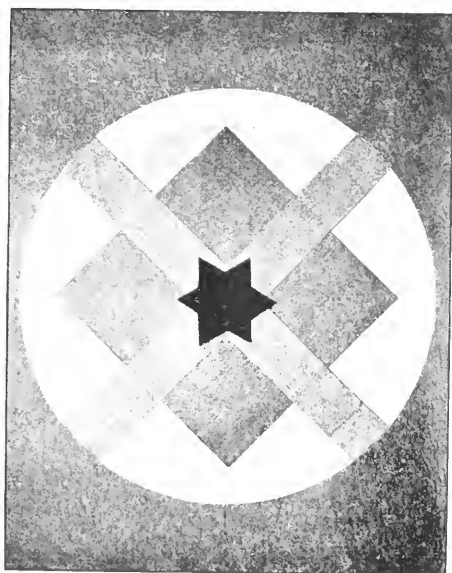

ORTHOCHROMATIC PLATE : INCANDESCENT
GASLIGHT.

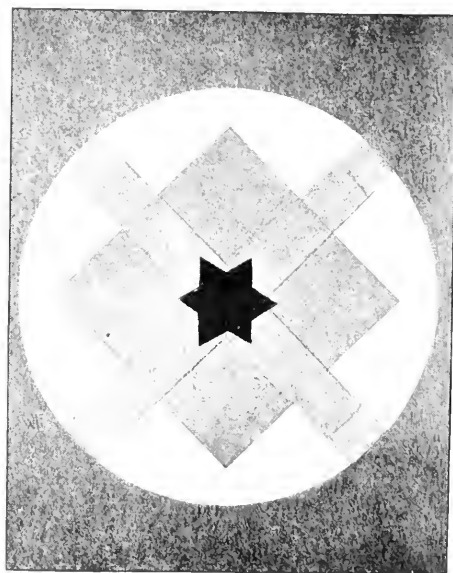

ORTHOCHROMATIC PLATE : YELLOW
GASLIGHT.

THE DESIGN PHOTOGRAPHED HAS BLUE GROUND, WHITE OUTER RING, PALE YELLOW INNER CIRCLE.
ORANGE SQUARE, EMERALD GREEN CROSS, BLACK CENTRE STAR.

extent resemble that which they are intended to represent. The outlines may be good, but the detail is generally poor and frequently altogether wanting. When, on the other hand, a photograph of an object is taken, it resembles the original in every respect, every line, every dot, and all the light and shade being faithfully reproduced. It is evident that for very accurate work photomicrography is the only process really available, and it is only for certain purposes—for instance, when certain detail is to be made more prominent and other detail cut down or left out—that the method of tracing with the *camera lucida* can be used with any success. The factors essential to the production of a photograph of an object magnified by the microscope are: (a) an illuminant, (b) a microscope with a camera attached, and (c) a sensitive plate. As the apparatus is a special one, it will be necessary to consider it rather closely, which can be done at the same time as the methods are explained.

THE ILLUMINANT—DAYLIGHT.

Ordinary daylight, especially that reflected from a white cloud, is to be preferred for general microscopic work, but is of little or no use for photomicrography, because it has not sufficient intensity. Direct sunlight, however, is the best illuminant if it can be depended upon, which unfortunately it cannot be in this country, and therefore other methods of illumination are more often employed. Dr. Woodward, of America, to whom we are indebted for much valuable information on this subject, has given a description of the method which he employed of illumination with sunlight reflected from a plane mirror fixed to a heliostat, and from this we take the following particulars:—The photomicrographic apparatus is fixed on a shelf near to the window of the dark room; the heliostat (Fig. 675) is placed outside the window, which is darkened with the exception of a small aperture, in which is fitted a lens mounted in a suitable tube. The lens employed is an achromatic combination about 2 in. dia-

meter, and of about 10 in. focal length. By suitable arrangement of this lens the solar rays are brought to a focus, and begin to diverge again before they reach the lowest glass of the achromatic condenser. In this way the solar heat is almost entirely removed, and it has been found that light could be obtained sufficient to give distinct vision and faultless definition upon a cardboard screen with a power magnifying 5,000 diameters, while the heat was so slight that the drop of water placed between the immersion lens and the cover glass did not require replenishing oftener than once in two hours.

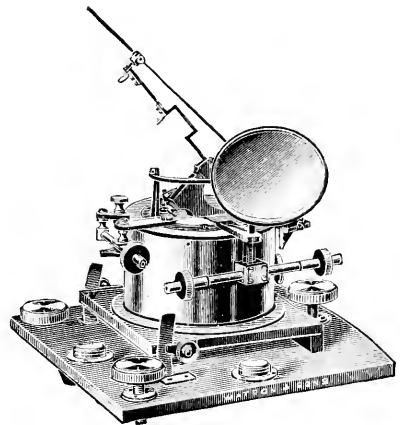

Fig. 675.—HELIOSTAT.

WORKING WITH THE HELIOSTAT.

With lower powers than this up to $\frac{1}{2}$ in. the light is so brilliant that it is not safe to view it directly down the tube of the microscope, therefore the image is received on a piece of white cardboard placed at an angle of 45° , upon which it may be viewed with both eyes and focussed without any particular difficulty. The sun's rays being reflected by the plane mirror on the heliostat through the large lens in the shutter, an ammonio-sulphate of copper cell is placed between this lens and the achromatic condenser on the microscope; then a black velvet hood is drawn down over the exposed portions of the microscope to prevent leakage of light into the dark room, when all is ready for the taking of a picture. It is not

absolutely necessary to shut out all light from the room, but it will be found far better, no matter what illuminant is used, to have as little stray light about as possible, because it is less trying to the eyesight, and its exclusion facilitates focussing. Dr. Woodward says that the time of exposure necessary for the production of satisfactory pictures of objects magnified 500 diameters or less is about a second, but with higher powers the time is much more prolonged; for in-

THE ARC LIGHT.

An arc lamp, when properly applied, forms a very suitable source of light for use in photomicrography. The light is very brilliant and concentrated, and is extremely rich in the actinic or chemically active rays. The apparatus should be enclosed in a lantern body, and the divergent pencils of light from the carbon points should be rendered parallel by passing them through the lenses or con-

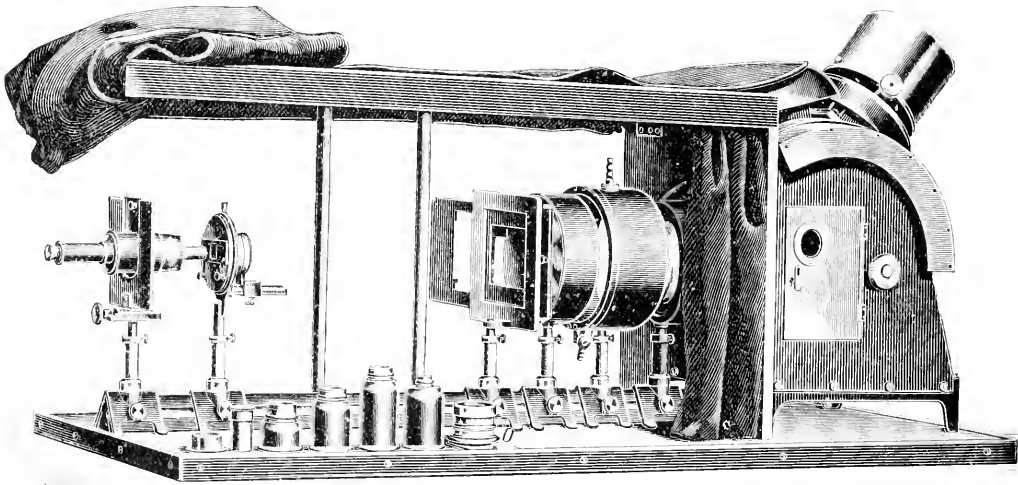

Fig. 676.—ZEISS'S ARC PHOTOMICROGRAPHIC APPARATUS.

stance, an object magnified 4,000 diameters requires in some cases as much as 25 seconds. By the employment of a right angled prism in the position of total reflection, or even an ordinary mirror, it was found that equally good pictures could be obtained; but this method entails a considerable amount of trouble in readjusting the reflector so that the beam of light may always pass through the lens in the shutter in the direction of the axis of the apparatus. When a heliostat is used it follows the apparent motion of the sun, so that the beam of light is always reflected in the same direction. The heliostat must, of course, be made for the latitude of the place where it is to be employed.

denser of the lantern; but, in addition, a similar condensing lens to the one described for solar light should be placed in the path of the rays. With such an arrangement objects magnified 400 diameters require less than one second exposure for the production of perfect pictures.

ZEISS'S PHOTOMICROGRAPHIC APPARATUS.

Fig. 676 shows the illuminating arrangement made by Zeiss, of Jena, in which an arc lamp is enclosed in the lantern to the right. The lenses are mounted on separate rods attached to accurately ground "saddles" or feet, which allow of their being moved backwards or forwards,

and clamped wherever they are required, upon a triangular iron rod; this method of fixing ensures that the lenses are always in the optical axis, and saves a considerable amount of time and trouble. The whole of the apparatus is covered by a light-excluding appliance consisting of a wooden top supported by iron rods with black cloth curtains on three sides. The body of the lantern has a door with a dark glass window for observation purposes, while the screw seen at the side is for the lateral adjustment of the carbons, a similar screw at the back serving for the vertical adjustment. As a suitable provision for the absorption of the heat rays, a water chamber is placed in the direct path of the rays near to the lantern. This chamber consists of a short cylindrical metal cell closed at both ends by plate glass discs; it is fitted with tubes, one of which is attached to the cold water supply, while another is connected to the sink; a stream of water may thus be caused to pass through the cell. A third tube at the top allows for the escape of air bubbles, and is useful for cleaning purposes when the apparatus is disconnected.

LIMELIGHT.

The oxycalcium light is another suitable illuminant for photomicrographic purposes; ordinary coal gas from the household supply and compressed oxygen from a steel cylinder being employed. The light is very intense, and, although not so white as the electric light, it is very rich in actinic rays. An apparatus made by Watson and Sons is shown by Fig. 677, consisting of an oxycalcium lamp and an aplanatic bull's-eye condenser mounted on a stand and fitted with centring screws for the adjustment of the lens. A cylindrical metal trough containing a light-filtering medium is placed between the light and the condenser. A similar arrangement manufactured by C. Baker is shown by Fig. 678, the illuminant being an oxyhydrogen lamp enclosed in a lantern body. The condensing system, seen on the front of the lantern, is conical, and consists of a condenser similar to

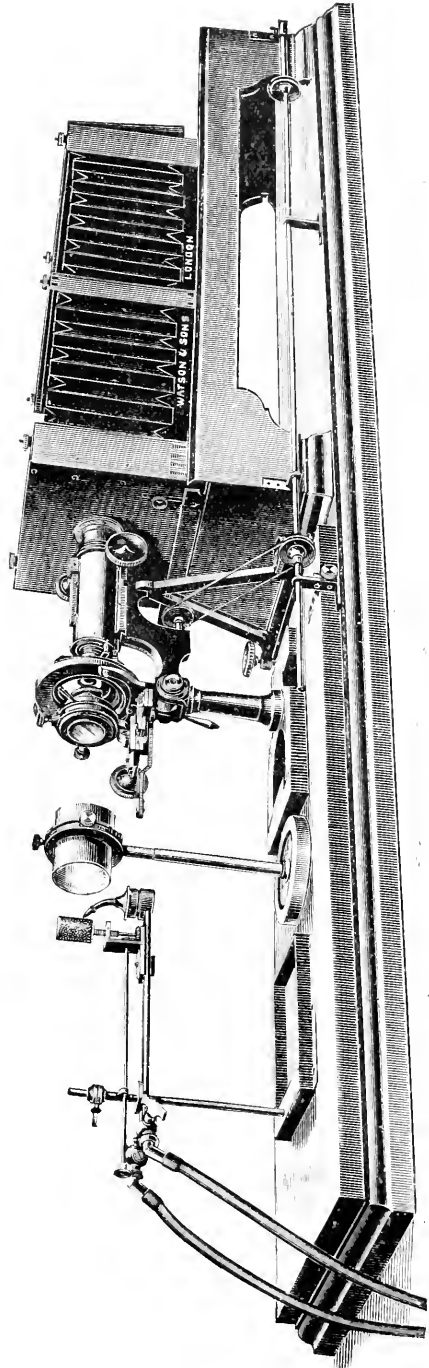

Fig. 677.—WATSON'S OXYCALCIUM PHOTOMICROGRAPHIC APPARATUS.

those used for projection lanterns, $4\frac{1}{2}$ in. diameter, in front of which is placed a

light emerges as a parallel beam $1\frac{1}{8}$ in. in diameter. The lens system is fitted with vertical and horizontal screw adjustments and an iris diaphragm.

OIL LAMPS.

The illuminants already considered are excellent in every respect, but they are somewhat expensive. For ordinary photomicrographic work with magnifications up to about 400 diameters, the homelier paraffin lamp or incandescent gaslight will be found, when properly applied, to be perfectly satisfactory. They do not give nearly the same intensity as those already considered, and therefore the time of exposure is more prolonged; this, however, is only a slight drawback in practice. With very high powers they are, perhaps, inadmissible, because the light is so faint on the screen that it is impossible to focus with any accuracy. The lamp should be one with a broad wick, and this should be kept carefully trimmed, the best result being obtained when the edge of the flame is set in the optical axis. Between the flame and the microscope a bull's-eye condenser is placed, and the rays are brought to a focus by placing a white card on the stage of the microscope and moving the condenser up until a fairly clear modified image of the flame is seen upon the under side of the card. The lamp and condenser are now in the best position for obtaining good illumination; and, in order to save time in subsequent work, it is advisable to make pencil marks on the baseboard where they stand, so that they may be always placed in the same positions. A better plan, however, is to fix a few small pieces of wood by means of screws to the baseboard where the lamp and condenser are placed; these pieces of wood then act as stops or indicators. Fig. 679 shows a simple photomicrographic apparatus made by R. and J. Beck, in which an oil lamp and condenser are used. Another somewhat similar but more elaborate arrangement, by Ross, is shown by Fig. 680. The superstructure is fixed on a solid mahogany baseboard and all parts are exactly central to each other.

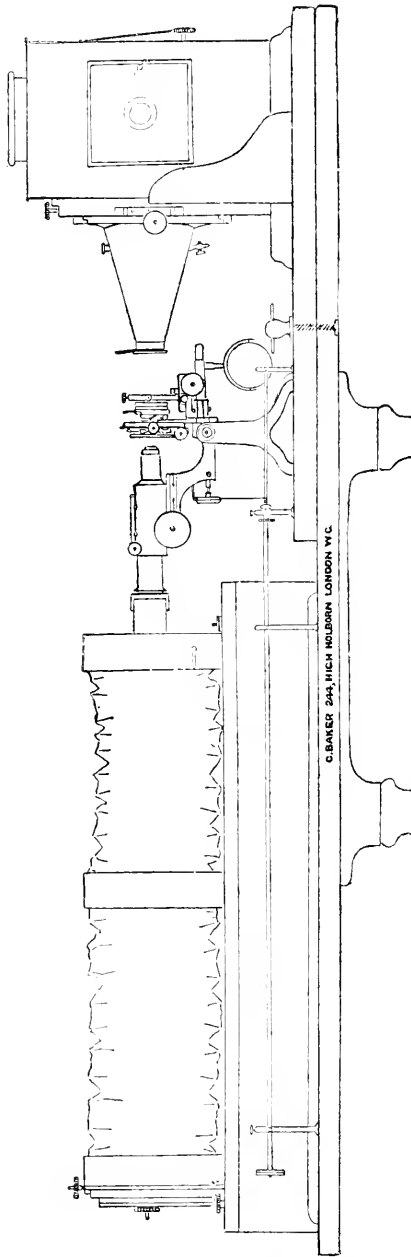

Fig. 678.—BAKER'S ONYCALCUM PHOTOMICROGRAPHIC APPARATUS.

two-lens system, the space between the lenses (7 in.) being filled with water. The

SUITABLE BURNERS AND WICKS.

A Paragon burner with a wick $1\frac{1}{2}$ in. broad will be found to give ample illu-

denser, and a substage condenser on the microscope, it requires about 30 seconds' exposure for an object magnified 200 diameters.

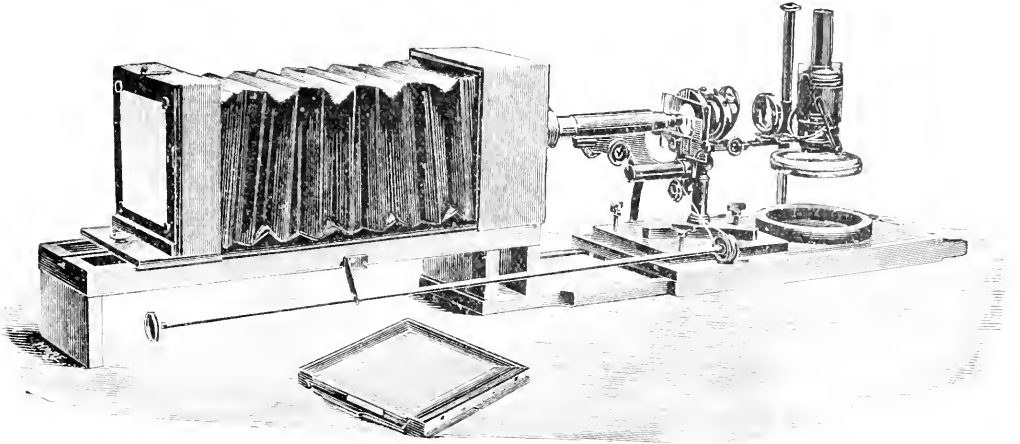

Fig. 679.—PHOTOMICROGRAPHIC APPARATUS FOR OIL LAMP.

mination. Hinks' patent duplex burners are also eminently suited for the purpose. A projection lantern with a triple wick and a condenser parallelising the rays in combination with a convex condenser

INCANDESCENT GASLIGHT.

For use in photomicrography an incandescent gas burner may be supported on a stand at the proper height so that the

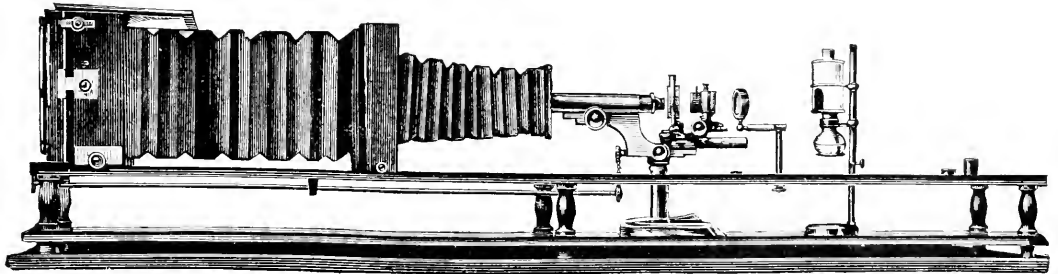

Fig. 680.—ROSS'S PHOTOMICROGRAPHIC APPARATUS.

3 in. diameter and 10 in. focus will be found to yield a very intense illumination. The flame of an oil lamp is much yellower than the illuminants already considered, and therefore its actinic value is not in proportion to its intensity; in consequence the exposures required are a little longer than would be the case with a whiter light of the same intensity. With an ordinary oil lamp, a bull's-eye con-

brightest part of the mantle may be used for illuminating purposes; or the burner may be mounted on an arm which can be made to slide on a metal rod and clamped in the proper position. If the old form of burner is used the chimney should be of mica, and the mantle should be supported upon a platinum wire stretching across the chimney at the proper height; the usual clay supporting rod cannot be

used because it produces a dark shadow in the centre of the field of view. In the newer Kern burners the support is a metal wire on the outside of the mantle and no chimney is required. Fig. 681 shows an incandescent lamp sliding on a rod as above described. It is fitted with a metal hood which cuts off all extraneous light, and may also be provided with an iris diaphragm, which, when partially closed, eliminates the structure of the mantle. If no diaphragm is used, then a slip of ground glass must be placed be-

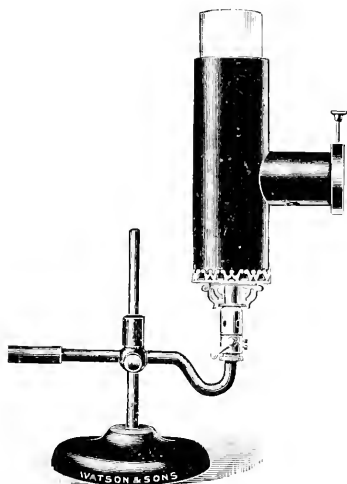

Fig. 681.—LAMP FOR INCANDESCENT GASLIGHT.

tween the burner and the microscope, or the structure of the mantle would appear on the focussing screen and would also be seen in the finished photograph. The incandescent gaslight is better than the light of an oil lamp, being more intense and also much richer in actinic rays.

OTHER METHODS OF ILLUMINATION.

There are three other methods of illumination which may be mentioned. The zirconia light is similar to the limelight, the cylinder being of zirconia and very much smaller than the lime cylinder; it gives a very brilliant light. The magnesium lamp burns magnesium ribbon or a mixture of powdered magnesium and chlorate of potash. Lastly, the acetylene

lamp, burning acetylene generated from calcium carbide, must be included. Both the magnesium and acetylene lights are more intense than the incandescent gaslight, but inferior to the electric light or limelight.

FACTORS REGULATING INTENSITY OF LIGHT.

Having chosen a suitable illuminant, it is necessary to have some measure of the intensity of the flame, as upon this depends the length of time required for exposing any particular brand of plate. Unless a determination of the actinic value of the flame be made there is no real guide to the exposures to be given, and consequently many poor or spoilt negatives may be produced before a satisfactory picture is obtained. The light, after it has passed through the different lenses, is generally a very poor one, far below ordinary daylight in its power, therefore more latitude is allowable in the exposures than is possible in taking an ordinary photograph; nevertheless it is much more satisfactory to know the value of the light than to time the exposures in a rule of thumb manner. The intensity of the light used will vary with the nature of the illuminant, the nature of the object to be photographed, the character of the objective, and other optical parts, and the distance of the plate from the source of illumination.

MEASURING INTENSITY OF LIGHT AND CONSEQUENT EXPOSURE OF PLATE.

The measurement of the intensity may be made directly by observation, or indirectly by exposing a plate and developing. With either method it is necessary that the camera, microscope, lighting arrangement, and other apparatus should be placed in their proper positions, as will be subsequently described, and that separate measurements should be made with each objective and each eyepiece both alone and in combination, as the amount of light transmitted is naturally very largely affected by the lenses used. A very simple method of direct measurement is by means of a Warnerke's

sensitometer screen; this consists of a plate of glass covered with squares of coloured gelatine, upon each square being an opaque number indicating its value in the scale of opacities (Fig. 6S2). This form of screen was at one time used for determining the speed of plates, but it seems now not to be obtainable. The amount of light passing through any square is nearly one-third more than that of the square which follows it. For the present purpose the screen is fitted in a wooden frame so that when it is placed against the ground-glass screen no light, except that which passes through the sensitometer, is visible. The velvet cloth is drawn over the head, and a short time is allowed to elapse in order that the eye may become accustomed to the dim light. A piece of card is now placed over the lower numbers if they show too brightly, and an observation is made: the highest number of the sensitometer that is visible is read off, and the sensitiveness of the photographic plate, determined as already described, being known, the correct exposure is easily found. Several trial exposures have to be made in the first place, and a table of times showing the exposures necessary for light of various intensities is constructed for subsequent work.

THE COLLINGWOOD WILLIAMS METHOD OF GAUGING LIGHT INTENSITY.

A method of measuring the intensity of the light has been devised by Mr. W. Collingwood Williams, B.Sc., who has kindly given us the following particulars: A thin orange-coloured paper was cut into 3-in. squares and varnished; these squares were then placed together in series of 2, 5, 10, 15, 20, 25, and 30, each series being mounted between two 3¼ × 3¼ lantern cover glasses in the usual way. The microscope, camera, lighting arrangement, etc., being fitted up in their proper positions for taking a photograph, a metal mask is placed at the back of the camera, the black velvet hood is drawn down over the head, and one of the screens is fixed by springs against the plain glass screen. If a disc of light is seen shining through the coloured screen, the next

higher one is put in place of it until finally only the very dimmest light is seen to pass, while the next higher screen submerges it altogether. The number of thicknesses of paper in the screen which allows only the very faintest light to pass is a measure of the intensity of the light.

MATHEMATICAL FACTORS INVOLVED.

If the intensity of the light be represented by I_n and the fraction which penetrates each film by f , the intensity after passing one film is $I \times f$; after 2 films, $I_n \times f \times f$, or $I_n f^2$; after 3 films, $I_n f^3$; and after n films, $I_n \times f^n$. If this is the final point, then $I_n \times f^n =$ a very faint light = I_m , say. Similarly with light of a

5	6	15	16	25
4	7	14	17	24
3	8	13	18	23
2	9	12	19	22
1	10	11	20	21

Fig. 6S2.—WARNERKE'S SENSITOMETER SCREEN.

different intensity I_m requiring m layers,

$$I_n \times f^n = I_m \times f^m$$

whence

$$(1) \quad \frac{I_n}{I_m} = \frac{f^m}{f^n} = f^{m-n}$$

and since the exposure necessary to produce equal density is inversely as the intensity of the light

$$(2) \quad \frac{E_m}{E_n} = f^{m-n}$$

and

$$(3) \quad f = \frac{E_m}{E_n}^{\frac{1}{m-n}}$$

If $m = n + 1$ (successive layers)

$$(4) \quad E_m = E_n \times f$$

i.e., the exposure for each successive thickness penetrated is the preceding exposure multiplied by f . To find f experimentally, use is made of relation (3).

METHOD OF APPLYING FOREGOING FACTS.

With a given plate it was found that an exposure of five minutes (*i.e.*, 300 seconds) to a light just penetrating 20 layers gave the same density as an exposure of 65 seconds to a light which just penetrated 27 layers. Hence

$$f = \sqrt[7]{\frac{65}{300}} = \sqrt[7]{.217} = .804.$$

If we now find experimentally the correct exposure necessary for a plate of known speed with a light which will just penetrate a known number of films, the development being carried on with ferrous oxalate, we shall know every other exposure necessary with other plates of known speed, and we shall also know the correct exposure with any light which has been measured by the coloured screens without further experiment. With these data a table may be constructed. If, instead of intensity of light, we consider its reciprocal dimness, this is directly proportional to the exposure, *i.e.*, $D = KE$ where K is a constant.

Express E in seconds and put $K =$ Hurter number (for convenience),

$$\begin{aligned} \text{then } D_{18} &= 14 \times 1000 = 14000 \\ &\text{or } 28 \times 500 = 14000 \end{aligned}$$

and similarly for all the photometer plates, so that now

$$\begin{aligned} E &= \frac{D}{H} \text{ and } H = \frac{D}{E} \\ D_n \times 1 &= D \times f. \quad f = .8 \end{aligned}$$

EXPOSURE TABLE BASED ON PENETRATIVE POWER OF LIGHT.

No. OF FILMS.	HURTER NUMBERS.					EXPOSURE IN SECONDS DIMNESS
	14	28	42	56	70	
18	1000	500	333	250	200	14000
19	800	400	266	200	160	11000
20	614	320	213	160	128	9000
21	512	256	171	128	102	7200
22	409	204	136	102	81	5700
23	327	163	109	81	65	4500
24	262	131	87	65	52	3600
25	209	104	70	52	41	2900
26	167	83	56	41	33	2300
27	134	67	45	33	26	1800
28	107	53	36	26	21	1450
29	86	43	29	21	17	1200
30	69	34	23	17	13	900

The above table shows the number of seconds' exposure required when plates of known speed (from 14 to 70 Hurter numbers) are exposed to light which will just penetrate a certain number (from 18 to 30) of films.

TESTING EXPOSURE BY DIRECT TRIAL UPON A PHOTOGRAPHIC PLATE.

The indirect determination of the intensity of a flame may be carried out by observing its effect upon a photographic plate. The apparatus being in position, and the light arranged so as to give the best result, the dark slide with a quarter plate should be placed in the camera. The slide should be drawn out to one-sixth of its full extent, and an exposure of 5 seconds' duration made, then the slide should be drawn out another sixth and another exposure of 5 seconds made: this should be done for the whole of the plate. By this time the portion first exposed will have received 30 seconds, the next portion 25 seconds, while the last portion will have received only 5 seconds. The plate is now removed and developed to the full extent with ferrous oxalate, fixed, and dried. The section showing a sufficient density will give the time required for exposing under the particular conditions. A trial plate will have to be made with each objective, or if objectives and eyepieces are used in combination, then with each combination. It is not necessary to make the determination with more than one brand of plate, because the H & D number of the plate being known, it is a simple matter to calculate the time required for any other brand of plate. For instance, suppose the H & D number of a particular brand of plate be 45, and the correct time of exposure 15 seconds, then for another brand of plate with an H & D number of 85, the correct time of exposure would be $15 \times \frac{4.5}{8.5} = 8$ seconds (nearly).

OTHER FACTORS AFFECTING EXPOSURE.

The difficulties of exposure are, however, greater than one would suppose, because account must be taken of the nature of the object, the amount of light and shade in it, its colour, etc.; and when an object of

any size, or which is distinctly coloured, is to be photographed, a measurement of the light should be made with the object in focus on the stage of the microscope. With objects showing black lines on a brightly illuminated ground, for instance crystals, the time of exposure is not of any great importance, as good pictures can be obtained either with long or short exposures.

portion of it may be thrown upon the condenser of the microscope. Monochromatic light, or what approximates more or less thereto, is also obtained by placing a coloured film or a layer of a coloured liquid between the source of light and the microscope. The coloured screens are usually made of gelatine or celluloid stained with aniline dyes; they are held by a separate stand,

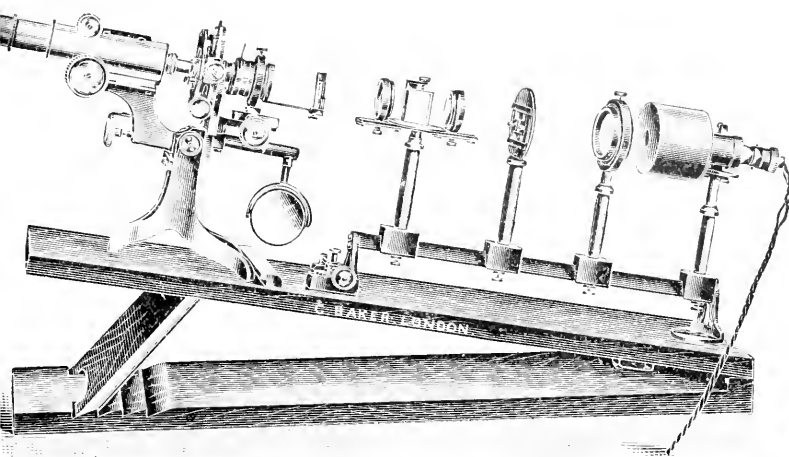

Fig. 683.—ARRANGEMENTS FOR OBTAINING MONOCHROMATIC LIGHT.

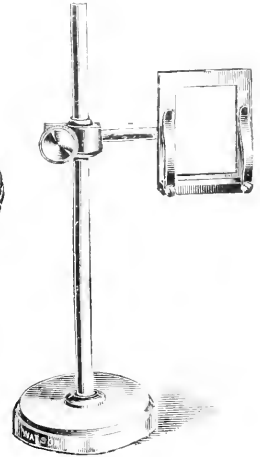

Fig. 684.—GIFFORD'S MONOCHROMATIC LIGHT SCREEN.

METHODS OF OBTAINING MONOCHROMATIC LIGHT.

For certain purposes it is advisable to use monochromatic light, or light of one particular wave length; this may be done either by screening off the remainder of the spectrum or by passing white light through certain coloured liquids or screens which absorb all the rays except those that are required. The apparatus used for obtaining monochromatic light from any part of the spectrum is shown by Fig. 683. It consists of an electric lamp of the Nernst form, an aplanatic bull's-eye condenser, an adjustable slit, an achromatic collimating lens, a prism, upon which one of Thorpe's replica gratings is mounted, and an achromatic projection lens. The spectrum produced by the prism may be screened so that the light from any

or are made to fit into the substage below the condenser. Gifford's monochromatic light screen (Fig. 684) consists of a trough in which is placed a $3 \times 1\frac{1}{2}$ in. slip of blue-green glass, the trough being filled up with a solution of aniline green in glycerine. Light passed through this screen, if examined spectroscopically, is seen to be composed of blue-green rays only, the red end of the spectrum being entirely absorbed. A saturated solution of acetate of copper may also be used, or the following solution:—

Pure nitrate of copper	...	160 grs.
Chromic acid	14 grs.
Water	$7\frac{3}{4}$ fl. oz.

Monochromatic light is used for obtaining what is known as critical illumination for high power work: for ordinary work it is not at all necessary.

USE OF COLOURED SCREENS.

In dealing with coloured objects it is desirable to interpose a coloured screen

plementary to that of the object as it is possible to obtain; for instance, with a yellow or brown object a blue screen should be used, and with a green object,

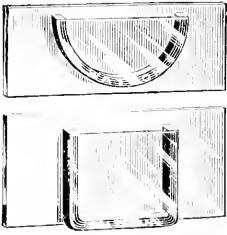

Fig. 685.—TROUGHS FOR COLOURED SOLUTION.

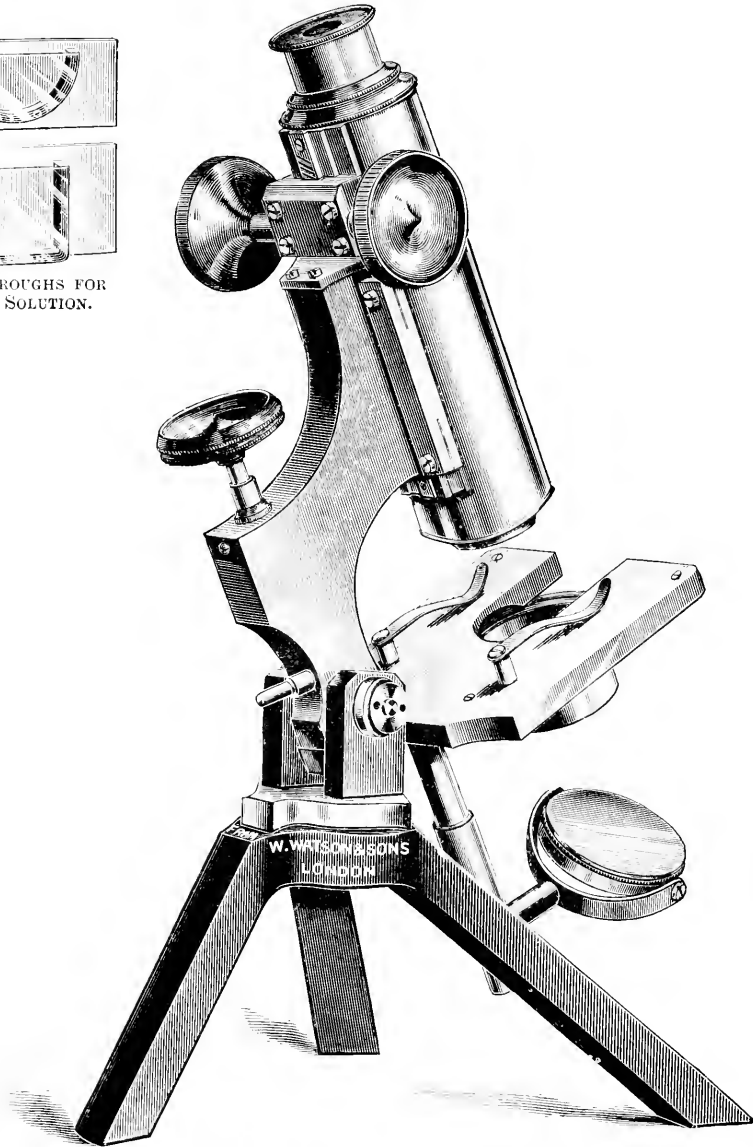

Fig. 686 —WATSON'S "FRAM" MICROSCOPE.

which will convert the colour as nearly as possible to a grey; that is, to use a screen the colour of which is as nearly com-

a violet screen. By so doing, the excessive contrast between the object and the brightly illuminated ground is con-

siderably reduced, and it is possible to obtain much clearer detail. If this is not done, then yellow or brown objects appear perfectly black and devoid of detail in the negative. For the yellow rays a trough (Fig. 685) filled with a dilute solution of potassium bichromate forms an efficient light filter. Screens of coloured glass may also be employed, but these are not perfect light filters, because in addition to the prevailing colour a faint spectrum is seen with many of the glasses when examined with the spectroscope; they are, however, quite suitable for this particular purpose. The interposition of coloured screens curtails the amount of light more or less, besides modifying its colour, hence it is necessary, when they are employed, to give very much longer exposures, and as the actinic power and visual intensity of the various colours are widely different, no measure of the length of exposure can be made other than by exposing a plate and developing. When coloured screens are used it is always best to employ isochromatic plates.

THE MICROSCOPE.

For photomicrographic purposes it is essential to use a good microscope, and as there are several makers who produce first-class instruments at a moderate price, the choice of one suitable for the work presents no difficulty. It is better to commence with a good modern stand, one or two good objectives, and one eyepiece, than to have a second-rate or old-fashioned instrument with a drawer full of accessories which nobody ever uses. A good stand will last a lifetime, because additions can always be made to it as the necessities of the work require, and as all fittings are now made in standard sizes it is very convenient to be able to buy these from any maker. It will be impossible to enter into a detailed description of the numerous microscopes suitable for photomicrography, but mention may be made of a few which may be regarded as typical; the various fittings will be separately considered. Fig. 686 shows Watson's

"Fram" microscope; Fig. 687, Baker's D.P.H. microscope; Fig. 688, Zeiss's stand for photomicrography; Fig. 689, one of Leitz's microscopes; Fig. 690, one of Ross's "Standard" microscopes; and Fig. 691, Swift's student's microscope.

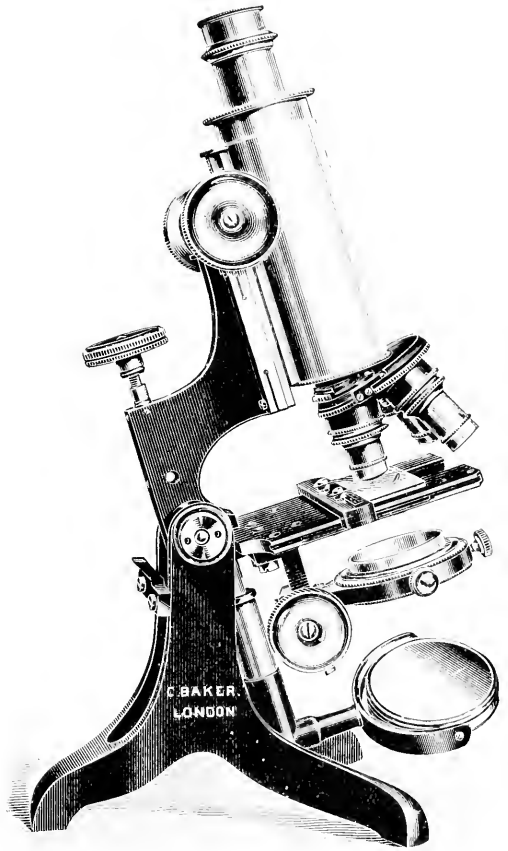

Fig. 687.—BAKER'S D. P. H. MICROSCOPE.

MOVEMENTS AND FITTINGS OF THE MICROSCOPE.

The microscope should be firmly planted on its support, so that there is no vibration when it is touched. There are two fundamental forms of support, the "horse-shoe" seen in the Zeiss, Ross, and Leitz microscopes, and the tripod as in those of Swift, Watson, and Baker; but, as a matter of fact, most makers now supply

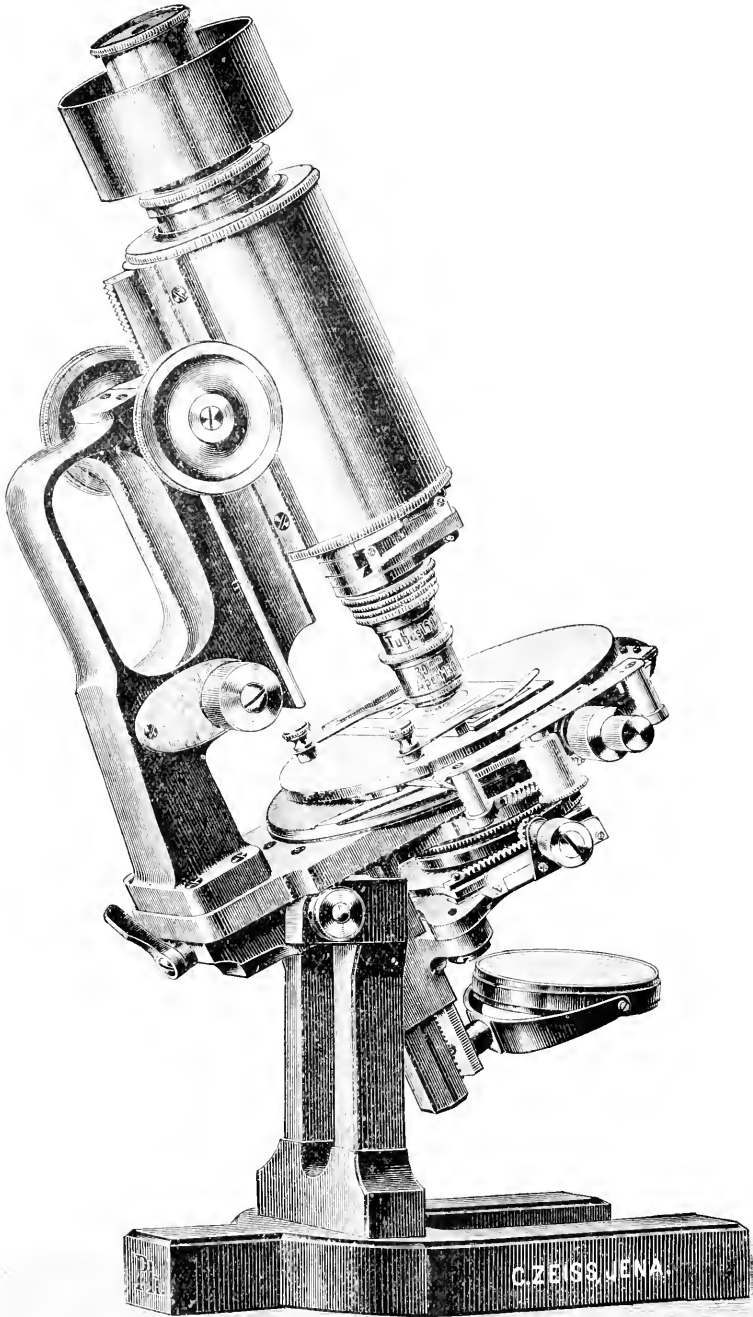

Fig. 688.—ZEISS'S STAND FOR PHOTOMICROGRAPHY.

both forms in various patterns. A desirable point is that when the microscope is placed in the horizontal position it should be quite as firmly fixed as when it is in the upright position. The tube of the microscope may be either 10 in. long (English model) or 6 in. long (Continental model), but the tendency at present is to construct instruments with a short outer tube and an inner graduated tube, which may be drawn out to make

out ring, or a proper substage with rack and pinion motion and centring screws. Below the substage also is the mirror; usually there are two mirrors, a plane one for parallel light, and a slightly concave one for condensing the light a little; these are mounted back to back in the same ring, so that either may be used by simply reversing the ring.

ACHROMATIC OBJECTIVES.

The most important portions of the optical part of the microscope are the ob-

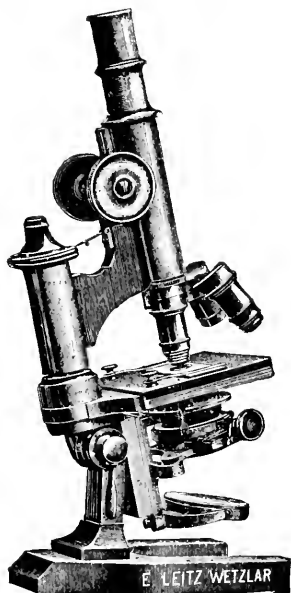

Fig. 689.—LEITZ'S MICROSCOPE.

the combined length whatever may be desired. Lengthening the tube in this way gives increased magnifying power without changing the lenses. When the objective alone is used for photomicrography, which is very often the case, it is convenient to unscrew the inner tube and connect the wide tube with the camera: by so doing a large field is secured. The stage of the microscope may be a plain one, though a mechanical stage is preferable; this is moved in two directions by milled heads at the side, so that after the glass slide has been placed in position it is not again touched with the fingers. Below the stage is a fitting for the condenser, polariscope, etc.; this may be a fixed ring, a swing-

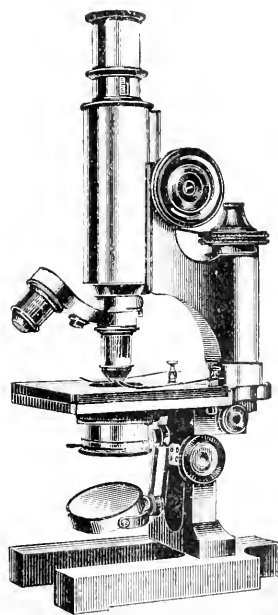

Fig. 690.—ROSS'S "STANDARD" MICROSCOPE.

jectives; they are designated as 2 in., 1 in., $\frac{1}{2}$ in., $\frac{1}{4}$ in., $\frac{1}{8}$ in., $\frac{1}{16}$ in., and so on, or by the Continental measures, 21, 16, 12, 8, 6, 4 mm., etc. These numbers represent, not the focal distances of the lenses, but the focal distances of simple lenses having equivalent magnifying powers. Objectives are now always constructed in such a way that they are achromatic; that is, they consist of a combination of lenses of flint glass and of crown glass, the rays of light refracted by the latter being

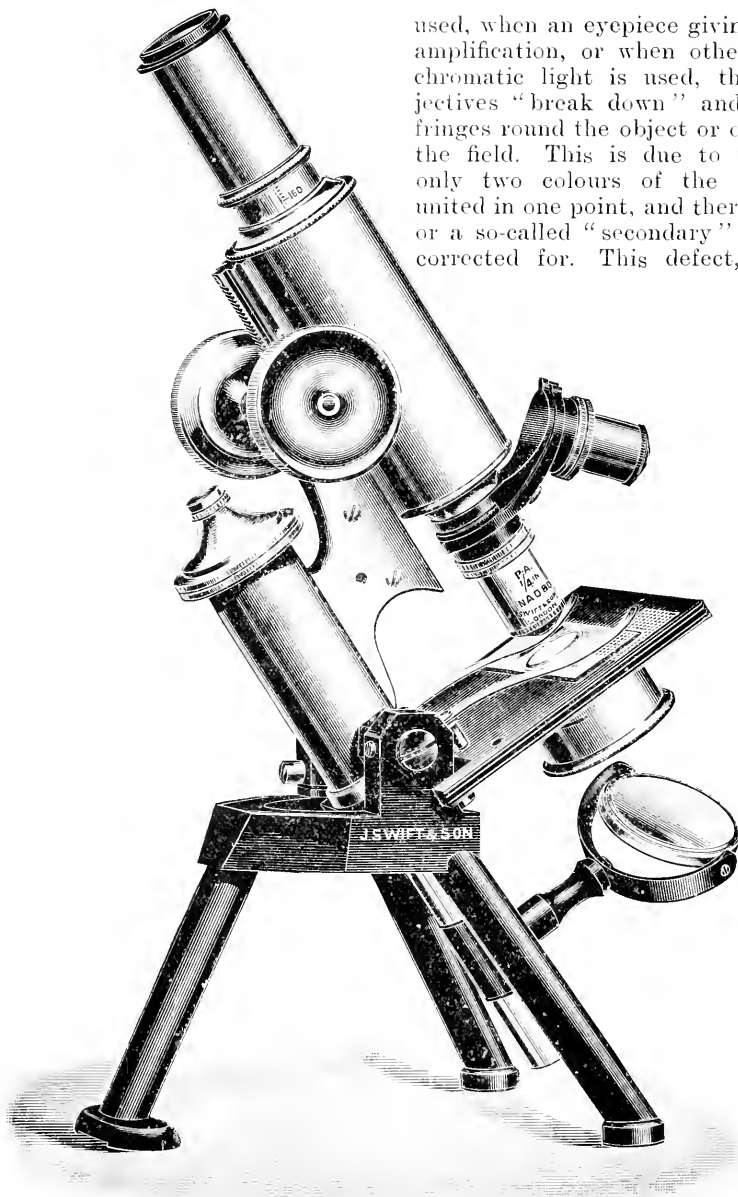

Fig. 691.—SWIFT'S STUDENT'S MICROSCOPE.

used, when an eyepiece giving a very high amplification, or when other than monochromatic light is used, then these objectives "break down" and show colour fringes round the object or on the limit of the field. This is due to the fact that only two colours of the spectrum are united in one point, and there is a residual or a so-called "secondary" spectrum uncorrected for. This defect, however, is

united by the former, and brought into focus at the same point. Thus the light which passes through them is practically colourless; but under certain conditions, for instance, when very oblique light is

not noticeable under ordinary conditions, as the objectives now made are infinitely better in this respect than the older forms. The improvements that have been made in microscopic objectives are largely due

to the firm of Schott, of Jena, who have introduced several new kinds of glass known as borate, phosphate, and baryta glasses, and to the late Professor Abbe and other eminent physicists who have made it possible to calculate the form of lenses best suited for any particular purpose

APOCHROMATIC OBJECTIVES.

Carl Zeiss, of Jena, has produced a series of objectives which may be regarded as embodying an entirely different principle to those previously in use; these objectives, termed by Professor Abbe "apochromatic" objectives, are so constructed as to unite three different colours of the spectrum in one point of the axis; thus the so-called "secondary" spectrum is eliminated, and whether they are used with monochromatic light, artificial light, or daylight, the results are equally good, the images produced by all the colours of the spectrum being nearly equally sharp. These lenses, however, suffer from the same defect as all objectives of high aperture—that is, certain colour defects are visible in the extra axial portion of the visual field (chromatic difference of magnification); the image formed by the blue rays being larger than that formed by the red, colour fringes are thus observed increasing towards the limit of the field.

COMPENSATION EYEPIECES.

Eyeieces are, however, made with an equivalent error of the opposite kind, so that the image formed by the red rays is larger than that formed by the blue; these are called "compensation" eyeieces. The apochromatic lenses used in conjunction with the compensation eyeieces for visual work, or with the "projection" eyeieces for photomicrography, give the best results it has hitherto been possible to obtain. The full-page plates, 25 and 27, show examples of photographs taken with these combinations (reproduced by kind permission of Carl Zeiss). Mr. Thomas Ross in improving microscopic lenses found that,

when the air angle, or what Professor Abbe later termed the numerical aperture, was increased, the thickness of the cover glass disturbed the corrections for spherical and chromatic aberrations; hence Zeiss produces objectives which are corrected for a medium thickness of cover glass 0.15 to 0.20 millimetres. Very frequently, however, high angle lenses are provided with a "correction" collar, which, when rotated, alters the distance between the front and back combinations (Fig. 692), and allows of adjustment to suit any cover glass thickness. Objectives of high power are now made to work with a drop of water or oil between the cover glass

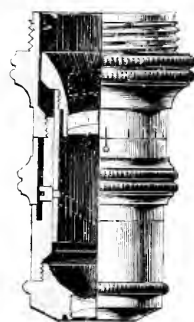

Fig. 692.—ZEISS OBJECTIVE WITH CORRECTION COLLAR.

and the front lens of the objective, and this has led to a considerable improvement; the numerical aperture (N.A.) being largely increased, more light is obtained because it is possible to utilise a larger cone of illumination, and the resolving and defining powers are largely augmented.

IMMERSION OBJECTIVES AND PROJECTION EYEPIECES.

In immersion lenses the working distance is increased, and no correction collar is needed, since their efficiency is practically independent of the thickness of the cover glass. The objectives working in water are known as "water-immersion" objectives, and those with oil are "oil-immersion" objectives or "homogeneous immersion" objectives. The oil used is cedar-wood oil, which when

thickened has nearly the same refractive index as the cover glass itself. For photomicrographic work objectives are frequently used without eyepieces, and increased magnifying power is obtained by extending the camera body; this cannot, however, be done beyond a certain point without material injury to the clearness of the image, which becomes more and more indistinct the further it is projected. When an eyepiece is used the light is dimmer, but this is compensated for by the fact that the magnification is largely augmented by it, and the camera can be made much shorter. When high amplification is required it is usual to employ

they vary with different makers. The initial magnifying powers of these lenses are approximately as follows:—

	A	B	C	D	E	F
Diameters	5	7.5	10	12	14.5	17

and the magnifications obtained with various combinations for a 10-in. tube (250 mm.) are given as follows, from Swift's list.—(See p. 529.)

MAGNIFICATIONS OF ZEISS ACHROMATIC OBJECTIVES.

Carl Zeiss gives the following figures for the magnification obtained with his

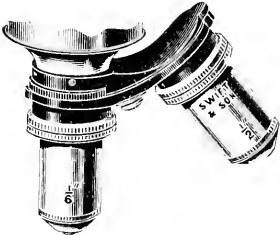

Fig. 693.—DOUBLE NOSEPIECE.

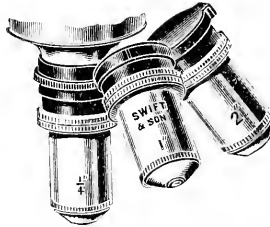

Fig. 694.—TRIPLE NOSEPIECE.

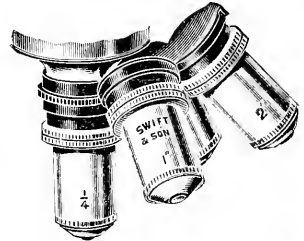

Fig. 695.—QUADRUPLE NOSEPIECE.

a "projection" eyepiece, by means of which a perfectly sharp image of the object may be thrown to any reasonable distance. For the purpose of rapidly changing objectives double, triple, and quadruple nosepieces (Figs. 693, 694, and 695) are provided; these screw into the bottom of the microscope tube, and they will take two, three, or four objectives, any one of which may in a moment be brought into the optic axis by rotation of the nosepiece.

HUYGENIAN EYEPIECES OR OCULARS.

The usual form of eyepiece is that known as the Huygenian (Fig. 696). This consists of two plano-convex lenses, with the plane surfaces towards the eye, and a stop between. Fig. 697 shows a section of such a lens. The denomination of these eyepieces is from A to F, according to their magnifying powers; the magnifying powers are, however, not a fixed quantity,

lenses. Magnifications of the Achromatic Objectives without Eyepieces calculated for 1 m. distance of the screen from the objective; and with Huygenian Eyepieces, calculated for 160 mm. tube length and 1 m. distance of the screen from the eyepiece.—(See p. 529.) On the same page, a corresponding table gives the magnification obtainable with some of Zeiss's higher power objectives. These tables will no doubt prove useful in enabling a ready estimate to be made of the precise character of the objective, and the eyepiece, if any, required for a given magnification.

MAGNIFICATIONS OF HIGH-POWER ZEISS ACHROMATIC OBJECTIVES, ETC.

Magnifications of the Higher Power Achromatic Objectives and of some of the Apochromatic Objectives with Projection and Compensating Eyepieces; calculated for 160 mm. tube length and 1 m. distance of the screen from the eyepiece.

TABLE SHOWING MAGNIFICATIONS OF SWIFT'S HUYGENIAN EYEPIECES.

Nominal Focus.	N. A.	Equivalent Angle in Air.	Magnifying Powers with Eyepieces.					
			A.	B.	C.	D.	E.	F.
1 inch	0.30	35°	60	90	120	150	180	210
"	0.30	35	90	135	180	225	270	315
"	0.50	60°	120	180	240	300	360	420
$\frac{1}{10}$ "	0.70	89°	150	225	300	375	450	525
$\frac{1}{15}$ "	0.88	120°	240	360	480	600	720	840
$\frac{1}{20}$ "	0.92	131°	372	558	734	930	1116	1303
$\frac{1}{30}$ "	0.97	152°	480	720	960	1200	1416	1680
		In water.						
$\frac{1}{10}$ "	1.15	101°	600	900	1200	1500	1800	2100
$\frac{1}{15}$ "	1.20	129°	720	1080	1440	1800	2160	2520
		In glass.						
$\frac{1}{10}$ "	1.26	112°	600	900	1200	1500	1800	2100
$\frac{1}{12}$ "	1.40	131°	720	1080	1440	1800	2160	2520

TABLE SHOWING MAGNIFICATIONS OF ZEISS'S ACHROMATIC OBJECTIVES.

Objectives.	Without Eyepieces or with Correction Lens.	Huygenian Eyepieces.					Highest limit of useful magnification.
		1	2	3	4	5	
a. a.	40	95	125	180	220	310	180
A.	65	175	225	310	390	575	210
A A	60	170	215	295	365	535	320
B	85	250	320	460	560	800	360
C	150	400	500	720	880	1260	420
D	240	700	880	1280	1560	2200	690
D D	240	700	880	1280	1560	2200	900
E	370	1080	1360	1980	2400	3410	950
F	570	1660	2080	3040	3720	5200	950
Pl.	40	100	130	190	230	335	120
D	240	700	880	1280	1560	2200	790
H	410	1220	1540	2220	2720	3840	1250
J	570	1660	2080	3040	3720	5200	1250
$\frac{1}{2}$ in. Oil immersion	570	1660	2080	3040	3720	5200	1380

TABLE SHOWING MAGNIFICATIONS OF ZEISS'S HIGH-POWER OBJECTIVES.

Objective, Designation or Focus.	N. A.	Descriptive No. (magnification) of Eyepieces.						Highest limit of useful magnification.
		2	4	6	8	12	18	
D D	0.85	410	880	1320	1700	2610	3960	900
E	0.90	720	1440	2160	2880	4320	6480	950
F	0.90	1040	2080	3120	4160	6240	9360	950
D	0.75	440	880	1320	1760	2640	3960	790
H	1.18	740	1480	2220	2960	4440	6660	1250
J	1.18	1040	2080	3120	4160	6240	9360	1250
$\frac{1}{2}$ in. Oil immersion	1.30	1040	2080	3120	4160	6240	9360	1380
$\frac{3}{4}$ mm.	1.30	667	1333	2000	2667	4000	6000	1380
2 mm.	1.40	1000	2000	3000	4000	6000	9000	1480

REMARKS ON FOREGOING TABLES.

It will be seen from these tables that there is no advantage to be derived, other than that of increased magnification, by

limit of useful magnification. For photomicrography the "projection" eyepieces

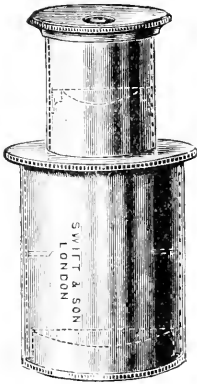

Fig. 696.—HUYGENIAN EYEPIECE.

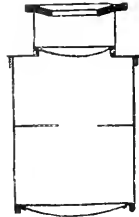

Fig. 697.—SECTION OF HUYGENIAN EYEPIECE.

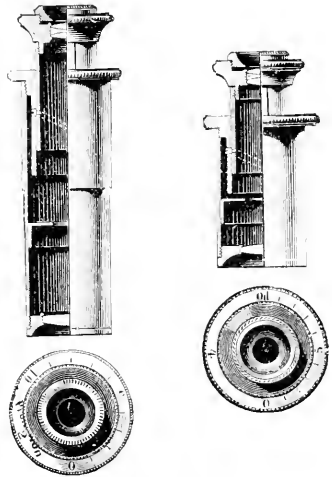

Fig. 698.—PROJECTION EYEPIECES.

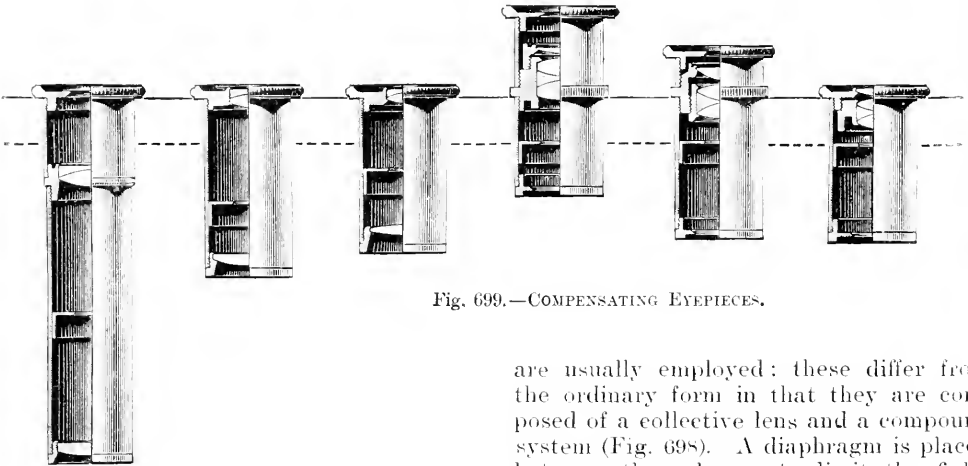

Fig. 699.—COMPENSATING EYEPIECES.

using an eyepiece of high magnifying power; it simply magnifies the image produced by the objective without adding to the detail—in fact, any imperfections due to defects in the objective are at the same time magnified and made more manifest. Of course, if the lens is a good one the image formed by it can be magnified very considerably without any appreciable defect, the amount that it can be so magnified being shown under the head of highest

are usually employed; these differ from the ordinary form in that they are composed of a collective lens and a compound system (Fig. 698). A diaphragm is placed between these lenses to limit the field, and the compound system is moved by revolving the eyepiece cap until a sharp image of the diaphragm is thrown on the screen; a scale is provided to register the proper position for any screen distance. The designation of these eyepieces denotes the magnifications which would be obtained by using these lenses alone. The eyepieces 2 and 4 give increased magnifications of 2 and 4 with a 160 mm. (6 in.) tube, or 3 and 6 with a 250 mm.

(10 in.) tube. Compensating eyepieces (Fig. 699) have already been mentioned; they are for use with apochromatic objectives only, but eyepieces are now made, with a sliding tube for correction, that can be used either with the ordinary achromatic objectives or with the apochromatics. The denomination of the

fitted to the stand holding the lamp (Fig. 701). The bull's-eye condenser is used with low powers, and is placed between the lamp and the microscope. The collective lens of Zeiss with an iris diaphragm is an improvement on the ordinary condenser, as it transmits only a circle of light sufficiently large to be utilised by the ob-

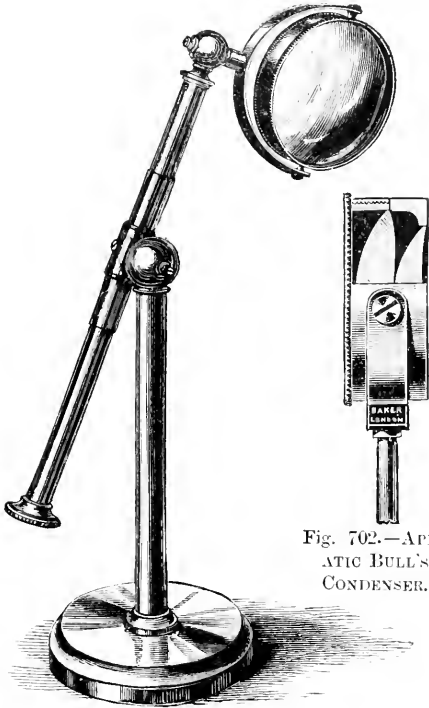

Fig. 702.—APLANATIC BULL'S-EYE CONDENSER.

Fig. 700.—BULL'S-EYE CONDENSER.

compensation eyepieces is also in accordance with their magnifying powers, 2, 4, 6, 8, 12, and 18.

THE BULL'S-EYE CONDENSER.

The simplest form of condenser or light collector is known as the "bull's-eye" condenser (Fig. 700). This is a single plano-convex lens mounted on a stand with a ball bearing at the top and a sliding rod, so that it may be placed accurately in the best position for concentrating the light on the object. It is sometimes

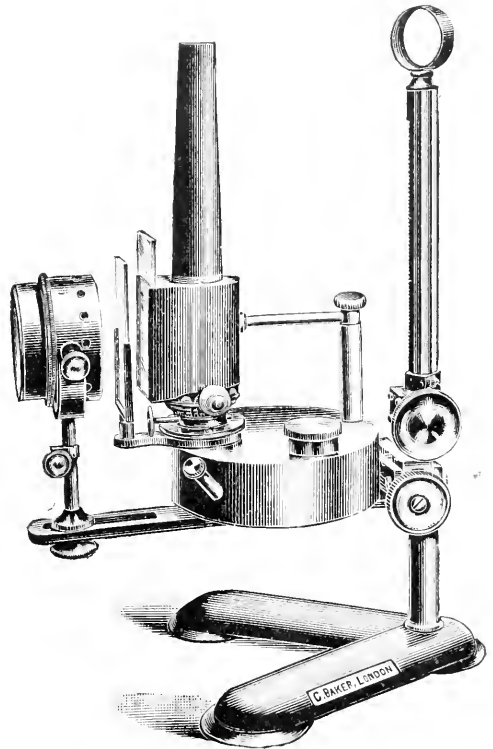

Fig. 701.—BULL'S-EYE CONDENSER ATTACHED TO LAMP.

jectively; with the incandescent light it serves to eliminate the structure of the mantle. The aplanatic bull's-eye condenser (Fig. 702) is a doublet (Mr. E. M. Nelson's), which gives much more brilliant illumination without so much spherical aberration.

STAGE AND SUB-STAGE CONDENSERS, DIAPHRAGMS, ETC.

The bull's-eye condenser cannot be used alone for illumination when high powers are employed; for these some form of stage or substage condenser has to be

employed. The stage condenser (Fig. 703) is mounted in a sleeve which slides into the tube below the stage; the substage con-

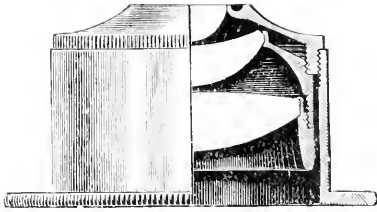

Fig. 703.—STAGE CONDENSER.

forms, one with a numerical aperture of 1.2 (Fig. 704), the other of 1.4 (Fig. 705), the amount of light collected by the latter being proportionately greater. Fig. 706 shows the "pan-aplanatic" condenser of Swift, N.A. 1.0; Fig. 707, a universal condenser (holoscopic system) by Watson; Fig. 708, an apochromatic condenser; and Fig. 709, an oil-immersion condenser by Watson. All these condensers are suitable for use with objectives of high magnifying powers. An achromatic condenser is much superior to an ordinary condenser,

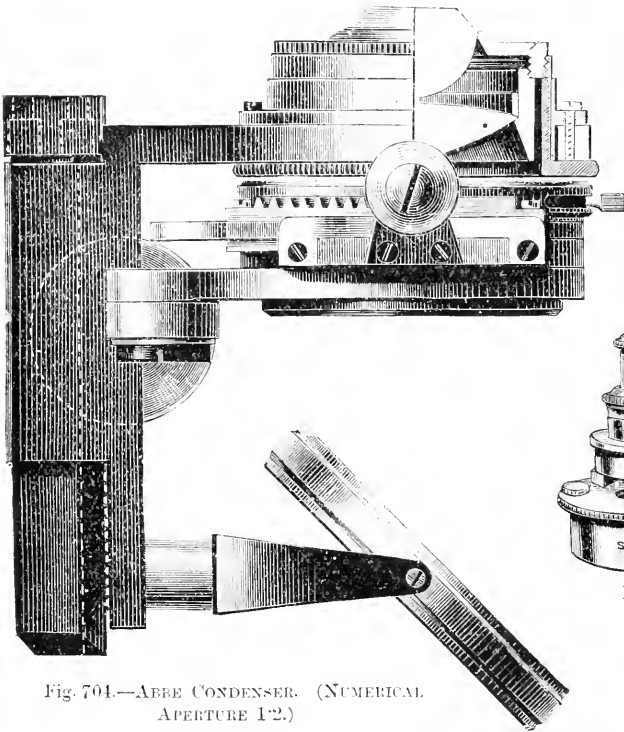

Fig. 704.—ABBE CONDENSER. (NUMERICAL APERTURE 1.2.)

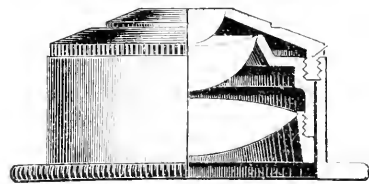

Fig. 705.—ABBE CONDENSER. (NUMERICAL APERTURE 1.4.)

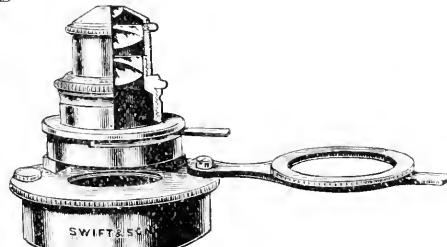

Fig. 706.—SWIFT'S "PAN-APLANATIC" CONDENSER.



Fig. 707.—WATSON'S "UNIVERSAL" CONDENSER.

denser is the same as far as the optical part goes, but it is fitted into the substage. These condensers are either non-achromatic, achromatic, or apochromatic. The non-achromatic condensers are composed of two lenses, while the achromatic and apochromatic condensers are made up of various combinations. A well-known form of achromatic condenser is the Abbe illuminator, which is made in two

as the light which it transmits is practically free from colour. The oil-immersion condenser objective is used with an oil-immersion objective, a drop of oil of cedar-

wood being placed on the front lens, and the condenser racked up until it touches the under surface of the glass slide on which the object is mounted; the light then passes in a straight path from the

spot lens is simply a plano-convex lens, upon which is painted a circle with black varnish, which prevents the central rays reaching the objective. But by far the best dark-ground illumination is obtained by means of the paraboloid (Fig. 713), a lens hollowed in the front, and in which is fixed a curved piece of blackened metal, which may be raised or lowered

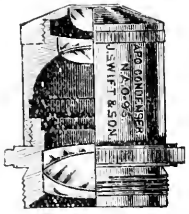

Fig. 708.—SWIFT'S APOCHROMATIC CONDENSER.

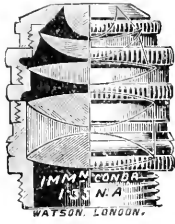

Fig. 709.—WATSON'S OIL IMMERSION CONDENSER.

condenser to the objective. The condensers are provided with interchangeable diaphragms of various sizes for use with



Fig. 710.—INTERCHANGEABLE DIAPHRAGMS.

the different objectives (Fig. 710). These are simply metal discs perforated with holes of various sizes in the centres; but the iris diaphragm (Fig. 711) has now almost superseded the older form, because it can be regulated to any diameter of opening by simply revolving the outer ring while the object is in focus, and in this way the illumination may be adjusted to show the greatest amount of detail.

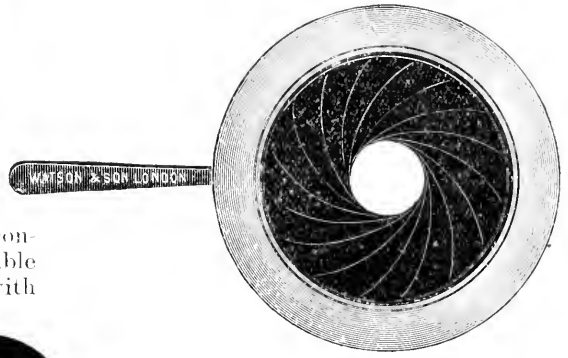

Fig. 711.—IRIS DIAPHRAGM.

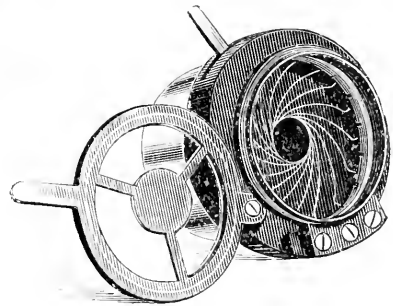

Fig. 712.—CENTRE STOP.

DARK-GROUND ILLUMINATION.

A rather effective method of illuminating objects such as diatoms, foraminifera, etc., under low powers is by means of the so-called dark-ground illumination: the ground appearing black, with the objects standing out in relief brilliantly illuminated. This is secured by placing a stop of a certain size—varying with the objective—at the back of the condenser (Fig. 712), or by using a "spot" lens. The

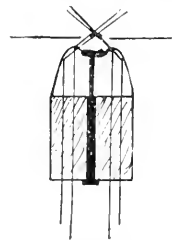

Fig. 713.—PARABOLOID.

by moving the pin passing through a hole in the centre of the lens. The parallel

rays reflected from the plane mirror are reflected from the internal surface of the paraboloid in a very oblique direction, and passing through the object illuminate it, while the field remains quite dark. Dark-ground illumination can only be satisfactorily obtained with objectives up

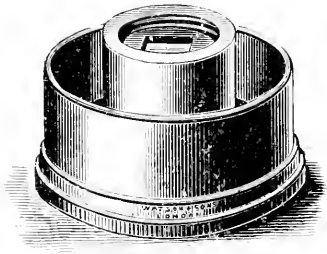

Fig. 714.—POLARISER.

to $\frac{1}{4}$ in. ; with high-angle lenses it is not possible to secure a perfectly dark ground because they take up some of the oblique rays. A photograph of diatoms taken in this way is shown in one of the Plates.

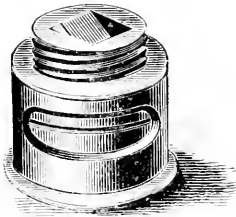

Fig. 715.—ANALYSER.

PRINCIPLE OF THE POLARISCOPE.

The polariscope used with the microscope is in two parts; the "polariser" mounted in a sleeve to slide into the tube below the stage or into the substage (Fig. 714), and the "analyser" mounted in a tube to fit over the objective or eyepiece (Fig. 715). Both the polariser and analyser consist of what is known as a Nicol's prism, that is, a natural crystal of Iceland spar which has been cut in a plane lying between its obtuse angles, *M*, *N*, *O*, *P* (Fig. 716), and the faces polished and cemented together in their original position with

Canada balsam. It is well known that when a beam of light is passed through an ordinary crystal of Iceland spar it is separated or refracted into two distinct beams of equal brilliancy, the crystal

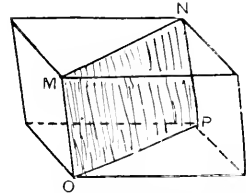

Fig. 716.—NICOL'S PRISM.

having the property of double refraction (Fig. 717). One of these beams obeys the ordinary laws of refraction, and is therefore called the "ordinary refracted ray"; it has a refractive index of 1.658. The other beam does not obey these laws, and

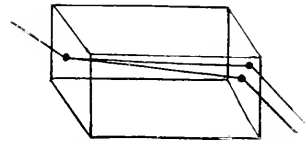

Fig. 717.—DOUBLE REFRACTION WITH ICELAND SPAR.

is therefore known as the "extraordinary refracted ray"; it has a refractive index of 1.486. When the Nicol's prism is used the extraordinary ray, having a lower refractive index than the Canada balsam, (1.53), passes through the prism a ray of

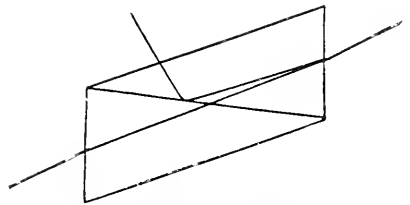

Fig. 718.—ACTION OF NICOL'S PRISM.

plane polarised light, while the ordinary refracted ray having a higher refractive index than that of the balsam strikes the surface of the latter at too high an angle, and it is reflected and submerged by the fitting (Fig. 718). If two Nicol's prisms

be placed in the same plane, so that the principal axis of the second lies in the same direction as the first, the ray of polarised light issuing from the latter will pass through the second prism unaltered, and the field of view will appear light; but as the second prism is rotated, less and less light is transmitted until the chief section is at right angles, when the field appears quite dark. If one of the prisms be rotated through 360° there will be two positions of maximum brightness and two positions of maximum darkness, at equal intervals of 90° .

SUITABLE SUBJECTS FOR THE POLARISCOPE.

Doubly refracting substances such as starches, horn, hoofs, fish scales, and crystals of tourmaline, selenite, quartz, aragonite, etc., give very fine effects with polarised light. Starch granules are brilliantly illuminated, and show black crosses (illustrated by one of the Plates), while many of the crystals yield very beautiful colours through "interference." Crystals of selenite, for instance, appear alternately red and green or blue and yellow. Many beautiful effects can be produced with sections of various rocks; also with sections of horn, muscular tissue, hairs, and crystals, and these form exceptionally good subjects for colour photography.

MOUNTING THE SPECIMEN.

The microscope is universally applicable to the examination of minerals, and of animal and vegetable structures; there is scarcely a single substance, however common, which, when examined in the proper way, will not reveal some more or less minute hidden structure which will well repay the trouble; in many cases the appearance of substances under magnification is so characteristic, that the microscope is one of the most useful instruments in analytical research. To give an adequate idea of the methods of mounting different objects would require a special treatise, therefore it will not be possible to do more than give a sketch in outline. Many objects, for instance the majority of

water animalcules, cannot be mounted in any but liquid media, because they would otherwise lose their shape; they are usually examined in a drop of water without any treatment; moving animalcules are killed by osmic acid or cocaine. Bacteria contained in fluids are mounted by placing a drop of the liquid upon a thin glass circle and drying down by a gentle heat; the circle is then passed three times quickly through a Bunsen burner to fix them, and, after cooling, the circle is placed in a solution of carbol-fuchsin or other aniline dye to stain the bacteria. The glass is then cleared of excess of colour by dipping in methylated spirit or other fluid, and, after drying, it is ready to be mounted permanently.

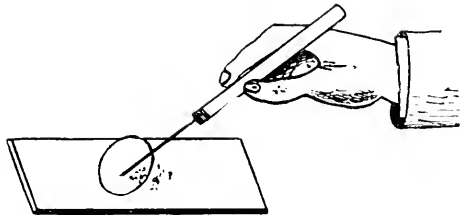

Fig. 719.—METHOD OF MOUNTING OBJECTS.

MOUNTING WITH CANADA BALSAM.

The mounting material is Canada balsam; as sold at the chemist's this is a thick fluid of honey-like consistency. It is placed in a saucer and baked in the oven until it is quite hard when cold; it is then broken up, placed in a wide-mouth bottle, and covered with benzol or zylol, and next day it is placed in a water bath and gently heated until it is fluid. A slip of glass, $3\text{ in.} \times 1\text{ in.}$, is taken and carefully cleaned; it is next placed upon an iron plate, which is gently heated; then a drop of the melted balsam is placed on the centre of the slide, and the thin glass circle is inverted over it so that the film containing the bacteria is toward the balsam. It is gently lowered by means of the needle (Fig. 719), and slight pressure applied with a clip until the balsam has set. The excess of balsam is removed from the edges of the cover with a little benzol and a rag, and the slide carefully cleaned. Objects

mounted in balsam require no further preparation, because they are practically permanent; but it is a very usual plan to finish off all slides with a ring of black varnish or of coloured enamel to give a better appearance. To do this the slide is centred on a turntable (Fig. 720), which is spun round at a rapid rate, and a camel-hair brush dipped in the black varnish or enamel is brought down vertically until it just touches the edge of the cover glass; the rotation of the slide causes the formation of a ring of the material which entirely covers the edge of the cover glass and seals it up. Fig. 721 shows a self-centring turntable, which, immediately it is rotated, brings the slide

and are mounted in Canada balsam under considerable pressure. Portions of insects are obtained by dissection, which is a rather delicate operation, and needs to be done under a low power lens to magnify the parts. Vegetable preparations are mounted in different ways: the seeds, pollen, etc., may be mounted dry, a ring of black varnish first being made on the slide in which the specimens are placed, and a cover glass is then cemented on with another ring of black varnish round it.

MOUNTING STARCHES, ETC.

Starches, etc., may be mounted in glycerine jelly or in one of the aqueous

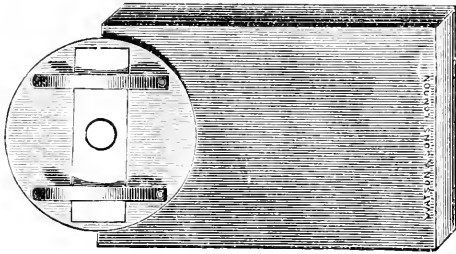

Fig. 720.—TURNTABLE.

into the exact centre; it will be seen that this is of importance for the formation of a perfect circle of enamel.

MOUNTING ANATOMICAL SPECIMENS, INSECTS, ETC.

Anatomical specimens are made either by dissection or by section. For dissection many instruments, such as knives and needles of various kinds, are used, and frequently parts of the structures are made more prominent by injecting coloured liquids—for instance, carmine—into blood-vessels. For section the tissue is hardened by immersion in alcohol or chromic acid, etc.; it is then either frozen hard or imbedded in paraffin wax, and extremely thin sections cut by a “microtome”—an extremely useful appliance—of which there are many forms (Fig. 722). Insects are usually softened by immersion in caustic potash solution; they are then soaked in alcohol, followed by turpentine,

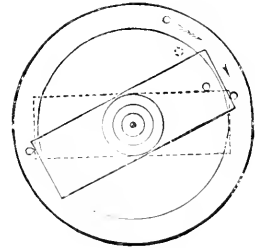

Fig. 721.—SELF-CENTRING TURNTABLE.

fluids. Glycerine jelly is made according to Lawrence's formula from: Gelatine, 1 oz.; glycerine, 6 drachms; and camphorated spirit, $\frac{1}{4}$ oz. The gelatine is covered with water, and allowed to stand till it becomes soft; it is then melted down by a gentle heat, a small quantity of white of egg added, and the mixture boiled to coagulate the albumen; the solution is then filtered through flannel and the glycerine and camphorated spirit added. For mounting, the glycerine jelly is melted down by a gentle heat, a drop taken out on to the slide on which the object has been placed; it is then covered with a thin glass circle as described for Canada balsam.

SECTIONS OF WOOD, MINERALS, ETC.

Sections of wood, seeds, etc., are obtained by cutting with a razor upon a simple section cutter (Fig. 723). A section of hard material such as bone,

rock, etc., is obtained by cutting with an iron disc which is mounted on a machine somewhat like a lathe, and caused to revolve at a high rate of speed; for very hard substances the cutting disc is fed with fine emery and water. The

their natural state: they are bleached by immersion in Eau de Javelle or a solution of hypochlorite of soda, which is made by mixing solutions of carbonate of soda and chloride of lime. They are stained by immersion in solu-

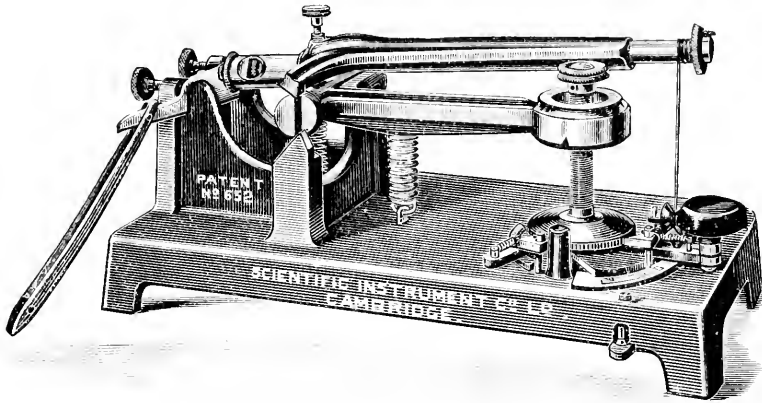

Fig. 722.—ROCKING MICROTOME.

section thus obtained is not sufficiently thin to be transparent; it is mounted on a glass slip and rubbed down, first on a grindstone and then on a Water-of-Ayr stone until perfectly flat and smooth on the one side; it is then removed and re-cemented upon another slip of glass, and rubbed down on the opposite face until it is equally smooth and the section is so thin as to be quite transparent. Great care is required at this point, because any rough treatment would result in the whole or a great part of the preparation being rubbed away, and the labour of many hours might be altogether wasted. When the section is sufficiently thin, a 3 in. × 1 in. glass slip is cleaned and made hot, a small quantity of melted Canada balsam is placed in the centre of it, and the section transferred to the slide; then more Canada balsam is put on, and the whole covered with a thin glass circle or square.

VEGETABLE TISSUES, DIATOMS AND FORAMINIFERA.

Many vegetable tissues are very dark coloured, and cannot be examined in

tions of various dyes, which bring out very prominently the different kinds of tissues. Diatoms and foraminifera are usually mounted dry. The slide is first

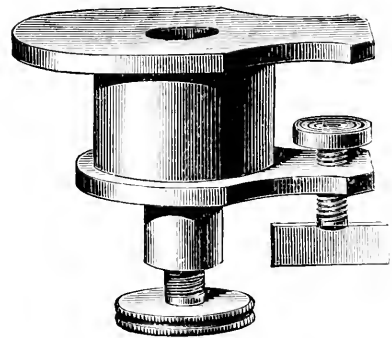

Fig. 723.—SIMPLE SECTION CUTTER.

prepared by making a circle in gum water and allowing it to dry; the diatoms, etc., are then arranged with a needle or a cat's whisker while under observation with a low power lens. By breathing on the slide the diatoms are fixed by the gum; the whole is then covered with a thin glass circle and ringed with black varnish.

THE "LIVE BOX."

Many of the larger water animalcule form interesting subjects while they are alive, because they are quite transparent and the working of the different organs can thus be seen; they



Fig. 724.—LIVE BOX.

must be enclosed in such a way that they cannot move, and this is effected by placing them, along with a drop of water, in a "live box." The live box (Fig. 724) consists of a plate of brass with a brass ring fixed in the centre, the ring being covered with a glass circle; another ring covered with a thin glass circle slides upon this, and is pushed down until the animalcula is held tightly. This form of live box cannot be used for high powers, because the latter cannot be brought sufficiently near to focus properly. The Rousset's live box, however, enables high

matter to get the object required into the field of view, and a good deal of time will be saved by examining first with the microscope alone, using a low power, and moving the slide until the object is directly in the centre of the field of view. The microscope may now be connected up with the camera, and a proper focus being obtained on the ground glass screen, the object will then appear in view; this will be the case even if the low power lens is replaced by a higher one before focussing on the screen, only a slight adjustment being required to bring it into the centre of the field. The position of an object on a permanently mounted slide may be at once located by fixing a small cone of gummed paper in such a position that the object is close to the tip of the cone; when the slide is placed on the stage of the microscope it is moved until the tip of the cone just passes out of the field of view, and the object is then at once discovered (Fig. 726). The Maltwood's "finder" is, however, the recognised apparatus for marking the position of an object for reference. The finder consists of a 3-in. × 1-in. glass slip on which are photographed a number of very small squares; each of these squares has two



Fig. 725.—ROUSSET'S LIVE BOX

powers to be used; it is larger than the ordinary form, and somewhat differently constructed (Fig. 725). Troughs (Fig. 655) are also used for examining water animalculæ under low powers; they are readily constructed by cementing together three pieces of glass, 3 in. × 1½ in., with marine glue; the middle piece of glass, having a half circle cut out of it, forms the trough, while the other two form the sides.

SEARCHING FOR AND MARKING POSITION OF OBJECT.

When the photomicrographic apparatus is connected up it will be found a difficult

numbers upon it, thus $\frac{37}{27}$, indicating its position both in the horizontal and vertical series. To use the "finder," the slide containing the object is placed upon the stage of the microscope, and the latter is moved by the milled heads until the object is in the centre of the field; the slide is then taken out and the finder put in place of it; the numbers which appear are now noted. When the object is required again, the finder is placed on the stage and moved until the recorded numbers are in the field of view; it is then replaced by the glass slip containing the object, which will then be in the field. This method is obviously a great convenience when working with high powers.

DETERMINATION OF MAGNIFICATION.

The magnifying powers of various combinations of objectives and eyepieces have already been given, but when the image is projected upon the ground glass screen at the back of the camera it is still further magnified in direct proportion to the distance of the screen. The magnification obtained may be calculated roughly by measuring from the objective, if the objective alone is used, or from the eyepiece, if that is also employed, to the ground glass screen. Let this measurement be "a," and let the magnification of the same combination when used with a 10-in. tube be "b," then the magnification *M* obtained with the camera is

$$M = \frac{a \cdot b}{10}$$

For instance, a $\frac{1}{8}$ -in. objective with a No. 3 eyepiece gives an amplification of 325 dia. ; with a camera 20 in. long the magnification is approximately—

$$\frac{20 \times 325}{10} = 650 \text{ dia.}$$

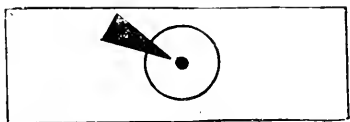

Fig. 726.—MARKING POSITION OF OBJECT.

THE STAGE MICROMETER.

It is, however, not a difficult matter to determine the magnification with any combination accurately. For this purpose a "stage micrometer" is employed. This consists of a 3-in. × 1-in. slip of glass, upon which is ruled a series of lines. There are usually 10 lines, the divisions being each $\frac{1}{1000}$ th of an inch; the space between the last two lines is further ruled, so that there are 10 divisions, each $\frac{1}{10000}$ th of an inch. The stage micrometer may also be obtained ruled in fractions of a millimetre. The micrometer is placed on the stage of the microscope and focussed until the magnified image of the lines ap-

pears sharp on a ground glass screen; the latter is turned with the rough surface towards the observer, and pencil lines are made to indicate the positions of at least five of these lines. The ground glass is then removed, and an ordinary foot rule placed upon it (Fig. 727); if five of the larger divisions correspond, say, with $2\frac{1}{2}$ in., the space occupied by one of the divisions will be $\frac{2\frac{1}{2}}{5} = \frac{1}{2}$ in., or $\frac{1}{100}$ th in. is therefore magnified up to $\frac{1}{2}$ in., or 1 becomes amplified to 50, therefore the magnification is 50 diameters.

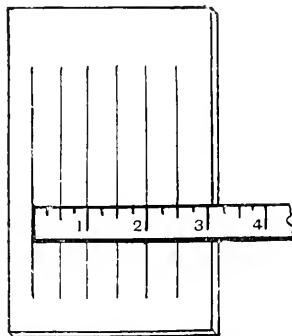

Fig. 727.—DETERMINING MAGNIFICATION.

THE CAMERA.

For photomicrography the camera is either an extending or bellows camera, or a non-extending or box camera; this is supported on a stand which is attached to a base board. The base board is 4 to 5 ft. long, about 10 in. wide, and $\frac{3}{4}$ to 1 in. thick. The base board is constructed to hold all the apparatus required—camera, microscope, and illuminant. Generally the camera is made to slide upon rails, and can be clamped in any position; in the bellows form the back of the camera may be moved while the front is fixed, thus allowing of extension. The microscope is clamped in position, and it and the illuminant are by preference fitted upon a separate stage made to revolve, so that it can readily be placed at right angles to the camera for bringing the object into view and focussing it. Both horizontal and vertical cameras are used; the former are more general, but the latter will be

found indispensable for certain classes of work; for instance, in photographing objects temporarily mounted in water, animalcula, etc., which would not remain in the field of view if placed upon the stage when the tube of the microscope was in the horizontal position.

position, and it is connected to a horizontal camera capable of extending to 36 in. Fig. 676, p. 514, shows the illuminating apparatus for a first-class photomicrographic outfit, consisting of an electric lamp enclosed in a lantern, and a portion of the so-called "optical bench" of Zeiss is seen. This consists of a triangular prismatic rail, which is fixed to the base board, and upon which the condensers, light modifiers, etc., are made to slide on "saddle" feet, and may be clamped in the most suitable positions. The apparatus shown by Fig. 728 is a very useful one, because it can be fixed either in the horizontal or vertical positions; while Fig. 729 is a vertical camera sliding upon a metal rod. A useful vertical camera is that designed by Dr. Van Huerck (Fig.

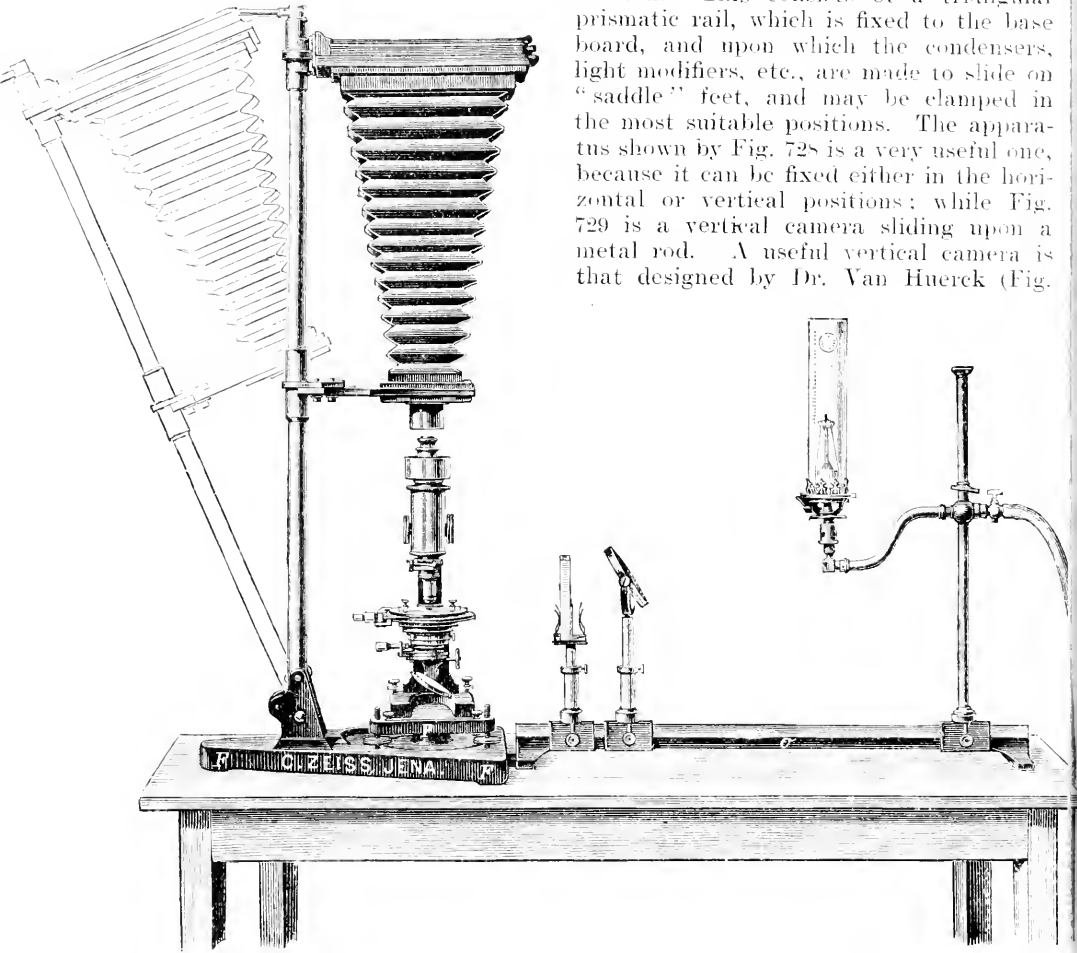

Fig. 728.—ZEISS'S VERTICAL AND HORIZONTAL CAMERA, ETC.

TYPICAL APPARATUS.

The apparatus shown by Fig. 677, p. 515, is a high-class one suitable for any kind of work, the illuminant being an oxyhydrogen lamp; the microscope is fixed with the tube in the horizontal

730). It is a conical box camera on four legs, and it has at one side a light-tight door which, when opened, allows of the direct focussing of the object without disconnecting the microscope. The Bausch and Lomb photomicrographic outfit, which is readily clamped in either a horizontal

or a vertical position, is shown by Fig. 731. Fig. 732 represents the very convenient vertical form of apparatus made by Messrs. R. and J. Beck.

THE FOCUSSEING SCREENS.

Two focussing screens are usually employed, a ground glass screen and a plain one. For the former the ordinary ground glass is too coarse. A finer screen may be made by rubbing together two plates

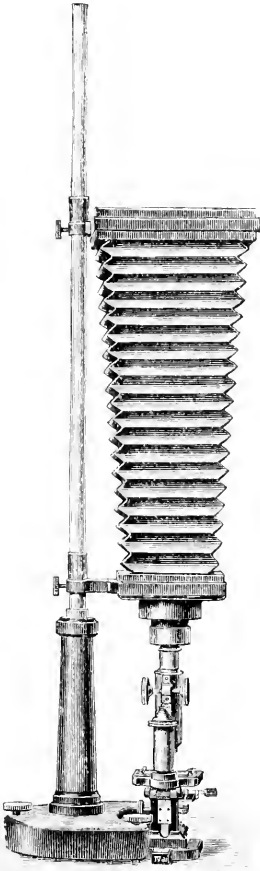

Fig. 729.—ZEISS'S VERTICAL CAMERA.

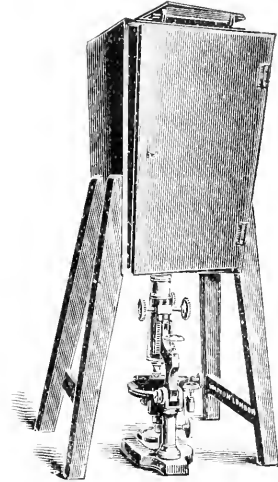

Fig. 730.—VAN HUERCK'S VERTICAL CAMERA.

of glass with a little flour emery and water between, or the ordinary ground glass may be coated with a thin film of paraffin wax. A fine screen may be made by coating a plain sheet of glass with a matt varnish made by dissolving—

Gum mastic	40 grains.
Sandarac	160 grains.
Ether	4 oz.
Benzol	1½ oz.

Inexpensive fine grain focussing screens,

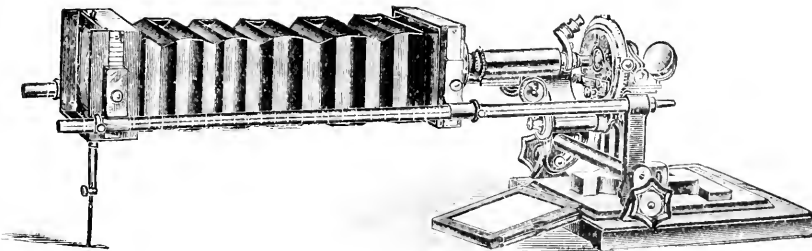

Fig. 731.—THE BAUSCH AND LOMB PHOTOMICROGRAPHIC OUTFIT.

sold under the name of "Micrograin," have just been placed on the market. Both the focussing screens should have lines ruled upon them meeting in the centre to facilitate the arrangement of the object in the best position.

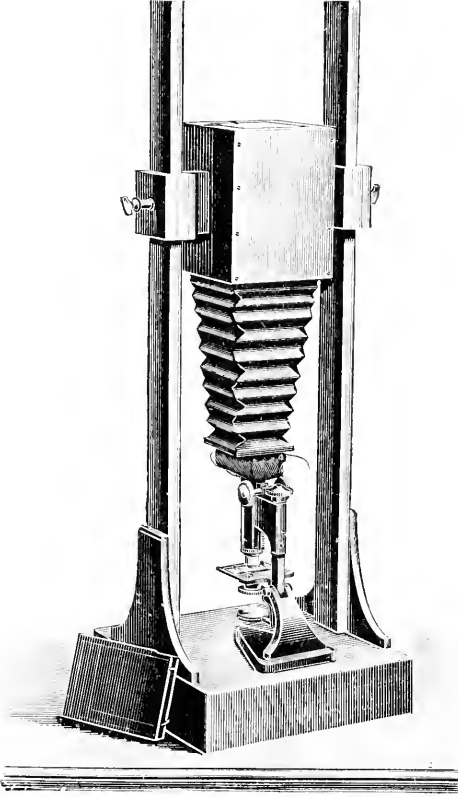

Fig. 732.—BECK'S VERTICAL CAMERA.

METHODS OF FOCUSING.

Focussing is commenced by turning the coarse adjustment head on the tube of the microscope, and finished with the small milled head which affects the fine adjustment screw. As this is a difficult matter with a long camera it is usual to fix a rod in bearings on the base board, and connect this with the fine adjustment by means of a pulley and a thin cord or elastic band, so that when the rod is revolved from the back of the camera it will cause the milled head to revolve

also. A simple device may be fitted up for this purpose (Fig. 733) consisting of a pulley supported upon a rod on each side of the milled head; a thin cord is next passed twice over the groove in the milled head, then over the two pulleys, and also over the pulley on the focussing rod; the milled head is then moved very easily without any side strain. The objectives now made are usually corrected for photography, so that when a perfect focus is obtained on the screen a similarly perfect image is obtained on a photographic plate; but in the case of some objectives it may happen that the visual and actinic foci do not always lie in the same plane, and however good the image on the screen may be, the negative is always indistinct: with such objectives a slight correction is therefore necessary.

CORRECTING FOR CHROMATIC ABERRATION.

The amount of correction required is measured by fixing a graduated arc on the base board at the back of the camera, and attaching a small pointer to the handle of the fine adjustment rod (Fig. 734). The object is carefully focussed on the screen, and a plate exposed and developed; this is placed beside the ground glass screen, and the handle of the fine adjustment rod is turned until the image on the screen appears as indistinct as it does in the photograph; then a second plate is exposed. It may be necessary to make two or three exposures before the correct actinic focus is found; but once this is obtained, the position of the pointer on the scale must be noted, and this serves as a guide in all future exposures. The apparatus devised by Mr. Shipperbottom (Fig. 735) allows six different exposure trials to be made on the same plate, and is useful for saving plates; it consists of a thin wood screen having a central opening divided into six segments of a circle; a circular screen having a diagonal opening revolves upon this, so that it alternately exposes and covers each segment. It is placed in the back of the camera directly in front of the dark slide, and the plate is covered after each exposure while the disc is being moved. By keep-

ing a record of the position of the pointer on the divided arc when each exposure is made, it is soon found what correction is required to give the best focus. This apparatus may also be used for directly determining the length of exposure necessary for any kind of plate, exposures for different times being made, and the density determined after development.

HIGH-POWER FOCUSING.

With low powers it is an easy matter to focus accurately on the ground glass screen, but when high powers are used the light is very dim, and it is necessary to use a plain glass screen: a simple lens such as is used for cloth "proving" being employed for viewing the object. The

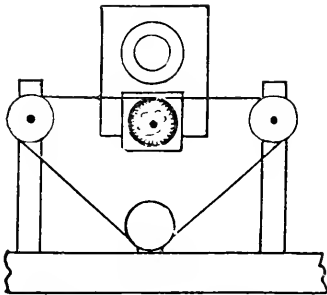

Fig. 733.—FOCUSsing DEVICE.

lens should be mounted in a block of wood or in any other suitable way, so that when it is placed against the screen the ruled lines on the front of the glass are in focus. A focussing lens will be found very suitable for this purpose, as the lenses are fitted in a mount which screws in or out of a tube to allow the focussing to be properly adjusted. Mr. George E. Davis uses, in place of a glass screen, for final focussing, a piece of mahogany pierced with a series of seven holes, into each of which an ordinary eyepiece can be fixed. The thickness of the slide is such that when the eyepiece is pushed in as far as it will go, the diaphragm lies in the same plane as the ground surface of the glass screen. It will be found more convenient to work in the dark room, as the eyes become better accustomed to the

dim light and are less fatigued; besides, the focussing takes up some little time, and it is a relief to do away with the

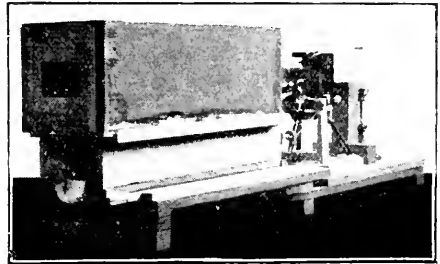

Fig. 734.—CORRECTION ADJUSTMENT TO FOCUSsing ROD.

black velvet hood, which is apt to become rather stifling.

SPECIAL APPARATUS FOR HIGH POWER WORK.

The different kinds of apparatus used for high power work have been separately considered. The illuminant must necessarily be an intense one, such as sunlight, the arc, or limelight. For the purpose of absorbing the less refrangible or heat rays a water cell or a trough filled with a solution of alum is placed in the path of the light. The objective should be one of the very best, preferably apochromatic, used in conjunction with a projection eyepiece, and the light should be con-

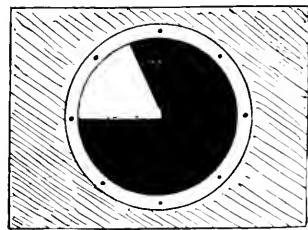

Fig. 735.—SHIPPERBOTTOM'S APPARATUS.

verged upon the front lens of the substage condenser, which should be of high aperture; the fine adjustment screw and the focussing rod should work with great precision, as everything depends upon

obtaining a perfect focus. When the object is focussed clear upon the plain glass screen the iris diaphragm may be shut down until the detail in the object comes out perfectly clear, then a plate may be exposed. The length of exposure necessary will have been obtained previously, by measuring the intensity of the light with the graduated screen as already described.

SIMPLE APPARATUS FOR LOW POWER WORK.

For general purposes, the apparatus for photomicrography need only be a simple one, such as that shown by Fig. 736, which may be made by anyone who has a know-

power, such as an inch objective, is to be used, the substage condenser is removed, and the bull's-eye condenser put in the optical axis; a piece of white card is placed upon the stage of the microscope, and the bull's-eye is moved up until a brilliant modified image of the flame is thrown on the card; this is the best position for the condenser. The card may then be removed, the object put in place of it; the focussing and the taking of the photograph are then essentially as already described.

THE DARK SLIDE.

The dark slide should be a double one, and its size will vary with the size of the

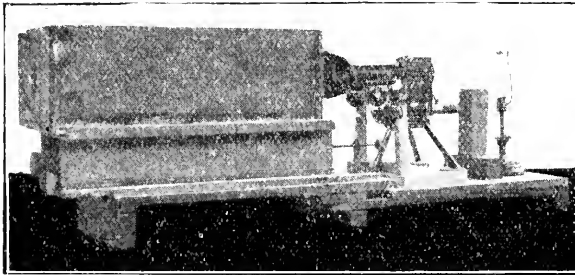
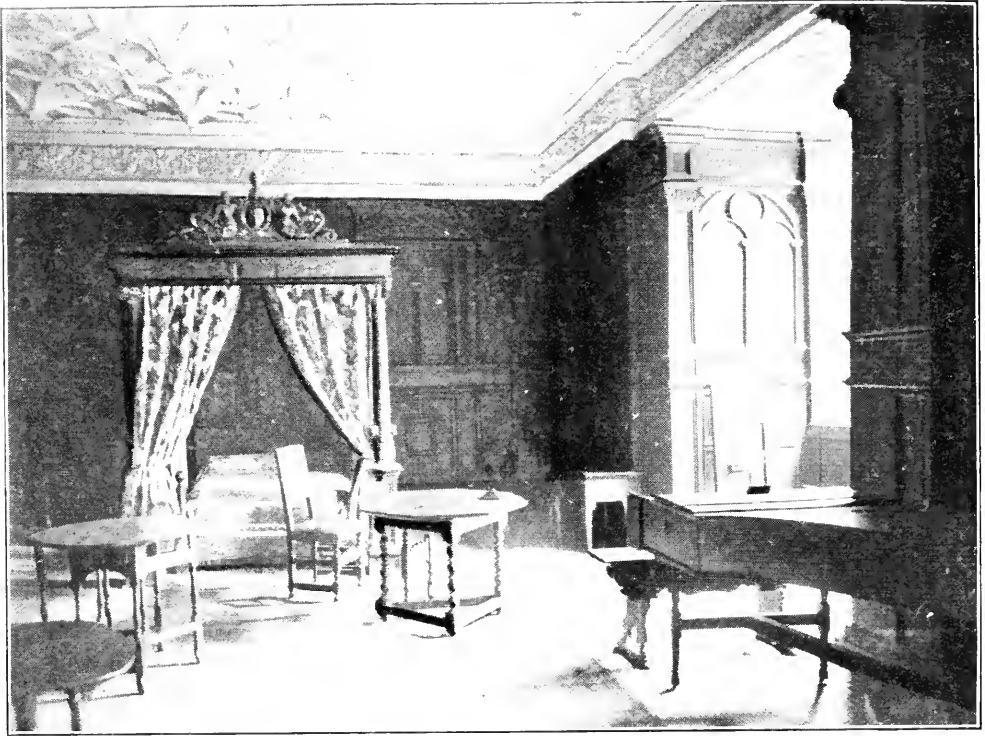

Fig. 736.—SIMPLE PHOTOMICROGRAPHIC APPARATUS.

ledge of joinery. The base board is 36 in. long, $8\frac{1}{2}$ in. wide, and $\frac{3}{4}$ in. thick. Upon it is fixed a wooden framework with grooves on the top, on which the camera slides. The camera is 18 in. long, $6\frac{1}{2}$ in. deep, and $6\frac{1}{4}$ in. wide; in the front is a circular opening covered by a short tube for connecting with the microscope; at the back is an opening 4 in. \times 3 in. with grooves up each side, in which the dark slide rests; there is a piece of wood at the bottom and a hinged flap subsequently mentioned for producing two pictures on the same plate. The microscope and the lamp are fixed on a separate board, which revolves on a pivot, and can be clamped with a thumbscrew in any position; this is for the purpose of focussing preparatory to connecting up with the camera. The light in this case is the incandescence gas light or a paraffin lamp. When a low

camera, either quarter, half, or whole plate. If the slide is larger than quarter plate it should be provided with carriers to take the smaller sizes of plates. The mahogany dark slides are better than the metal ones, as the slides usually draw out more easily, and there is therefore less vibration imparted to the apparatus; if they are at all stiff a little blacklead should be rubbed on the grooves. It is not often that a picture larger than quarter plate is required; in fact, for most objects a smaller plate even than that could be used with advantage. A simple device for taking two pictures upon a quarter plate may be made as follows:— In the back of the camera (Fig. 736) a piece of wood is fixed upon two hinges; when raised this brings the bottom half of a quarter plate dark slide into the centre. An opaque slide for



PANELLED ROOM VICTORIA AND ALBERT MUSEUM.

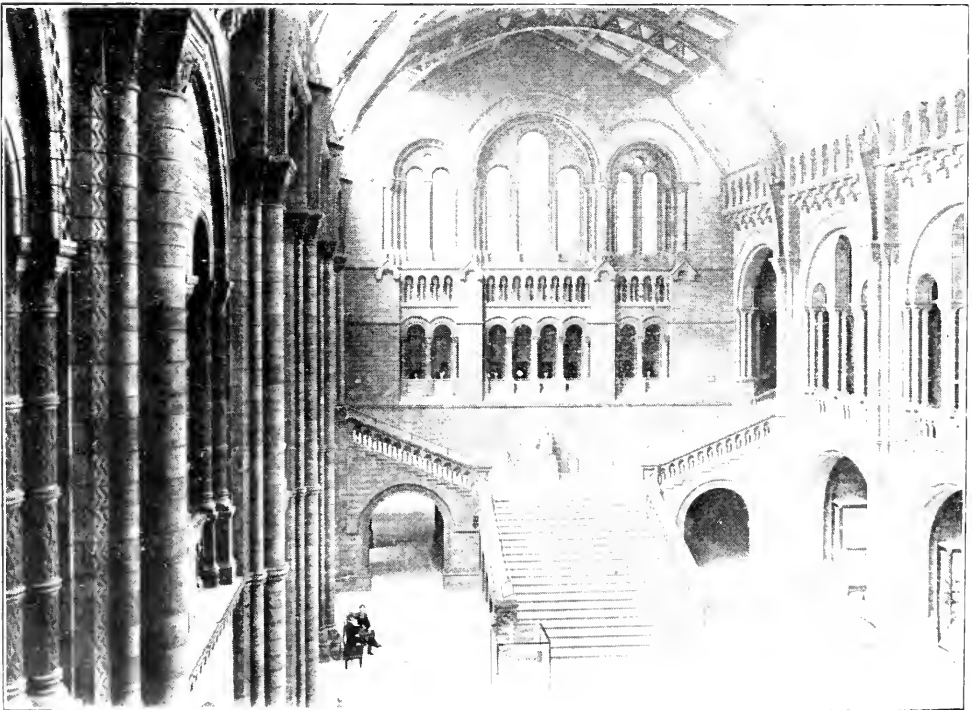

INTERIOR, NATURAL HISTORY MUSEUM, SOUTH KENSINGTON

the back of the camera is then cut in sheet zinc, and a rectangle 3 in. \times 2 in. is cut out of this, so that the opening thus made corresponds with the bottom half of the photographic plate. After the first exposure the slide is opened in the dark room, and the sensitive plate turned round so that in the second exposure it will also be in front of the opening in the zinc plate. With such a device two pictures

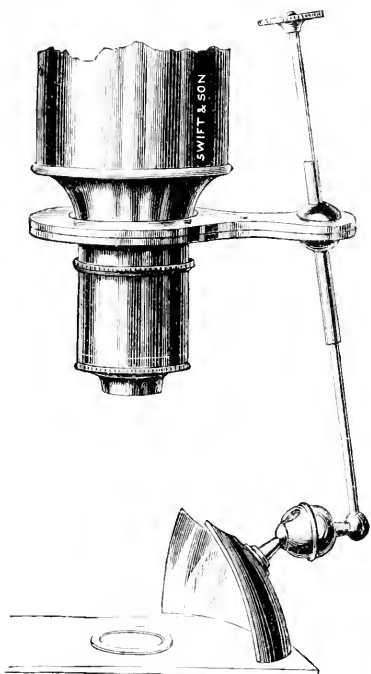

Fig. 737.—PARABOLIC SIDE REFLECTOR.

3 \times 2 in. divided by a transparent line will be obtained on the one plate. In determining the intensity of the light and in photographing bacteria and other minute objects this will be found a saving in plates, and the work will be quite as satisfactory as if it were done upon whole quarter plates. When a whole quarter plate has to be exposed the hinged flap of wood is allowed to drop outwards, and the dark slide can then be used to its full extent. An arrangement on the same principle can be used to adapt any size of camera for photomicrographic work.

SPECIAL METHOD OF PHOTOGRAPHING OPAQUE OBJECTS.

So far only transparent objects, which are photographed by transmitted light, have been dealt with; opaque objects, such as etched metals, etc., require to be illuminated by reflected light, and necessarily the apparatus is slightly modified. The usual plan of illuminating by reflected light is to place the lamp at the side of the microscope and to concentrate the light upon the object by means of the bull's-eye condenser; but the illumination is then all on one side, and raised objects,

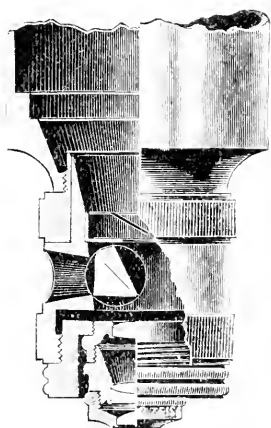

Fig. 738.—ZEISS'S VERTICAL ILLUMINATOR.

such as microscopic corals, etc., are in deep shadow on the side opposite the light. To obtain a good light on both sides of the object the parabolic side reflector (Fig. 737) is placed on the stage of the microscope, and the light from the condenser is reflected from it. This method of illuminating is possible only with low power objectives, as they have a considerable focal length; with high power objectives the focus is so very short that the objective casts a shadow on the object, and it is impossible to get any light on the object in this way. The vertical illuminator of Zeiss (Fig. 738) can, however, be used for high powers; it consists of a short tube with a circular opening in the side; in front of this opening is a small prism, which may be rotated by a

milled head outside the tube. The illuminator is screwed upon the body tube of the microscope in front of the objective. A beam of light is projected through the opening of the illuminator, and is reflected from the surface of the prism through the objective on to the object below, the image of the object being visible through the open half of the objective. A vertical illuminator may also be obtained, in which the light is reflected from the surface of a thin glass circle fixed at an angle of 45° , through which the object is easily visible (Fig. 739).

THE PLATE: FINENESS OF GRAIN.

The beauty of a photomicrograph necessarily depends upon the perfectly clear production of the smallest detail,

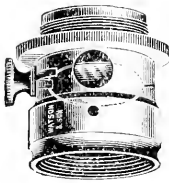

Fig. 739.—WATSON'S VERTICAL ILLUMINATOR.

hence the grain of the plate is of great importance; rapid plates having a coarse grain are not so good for this purpose as the ordinary or slow plates with a fine grain, though the use of the latter necessitates longer exposures. Albumen plates have perhaps the finest grain, "process" plates being also very suitable; the latter give considerable density and contrast. Isochromatic plates are, of course, best for coloured objects. Backing should not be omitted, or halation is practically inevitable. After exposure the plate is developed and fixed in the ordinary way, and as the various methods have already been very fully described, little need be said upon this point.

DEVELOPMENT.

If the exposure has been correctly timed the plate may be developed with ferrous oxalate; but equally good results

will be obtained by using hydroquinone, which is quicker, and which will often produce a fairly good negative even when under-exposed, if the development be prolonged. Pyrogallol, with sodium carbonate and sulphite, produces very good printing negatives, but if ammonia is used the plate may show signs of fog before the detail is fully brought out. Glycin is admirably adapted for the purpose, and is a great favourite, owing to the fine gradation and excellent detail obtainable by its use. A good formula is:

Glycin	50 grs.
Sodium Sulphite	125 grs.
Potassium Carbonate	260 grs.
Water (hot)...	8 oz.

The glycin should be added gradually, and the solution allowed to cool before using. Whatever method is employed, the development of a photomicrographic negative should, as a rule, be carried much further than for ordinary purposes, or it will be found on fixing to lack sufficient density.

SUITABLE CONTACT PROCESSES AVAILABLE.

The production of a print from the negative presents no difficulty, the ordinary printing-out paper being very suitable for the purpose; this must be smooth or glossy, and the finished prints are improved by burnishing. Rough or matt paper is totally unfit for the purpose. For increasing the contrasts a slow bromide paper, such as gaslight Velox, etc., may be employed; this should also be smooth. Such paper is very suitable for objects showing black lines on a transparent ground, such as crystals, diatoms, etc., but not so suitable for structures containing much detail, such as botanical and anatomical sections.

APPLICATION OF TRICHROMATIC PHOTOGRAPHY TO THE MICROSCOPE.

Coloured objects, especially those giving a play of colours when viewed under polarised light, cannot be adequately represented by an ordinary photograph in black and white, and until the methods

of delineating objects in their natural colours had been perfected, it was not possible to give any idea of their beauty. By the processes of Ives and of Sanger-Shepherd, photographs can now be taken and viewed in their natural colours, and these processes can be applied to the ordinary photomicrographic apparatus. As the methods have already been fully described it is not necessary to give a complete account. The Sanger-Shepherd process appears to be the most generally useful, because the photographs can be viewed without any special apparatus, and may be projected by the lantern up to discs of 12 ft. by the ordinary limelight, or to 20 ft. or even more with the electric light. The pictures produced by the Ives process have to be viewed in a special apparatus, and by the optical lantern can only be projected in discs up to 2 or 3 ft. By the Sanger-Shepherd process three photographs of the same object are taken on a plate 8 in. \times 3½ in., each photograph being taken under a different coloured screen. The screens are: bluish green (or minus red), pink (or minus green), and yellow (or minus blue). Three prints are then obtained from these negatives upon specially prepared coloured transparent media, and these three prints mounted together form the finished photograph, which by transmitted light shows all the beauty of the original object.

STEREO-PHOTOMICROGRAPHY.

Stereo-photomicrography is applicable only to those objects which can be examined with low powers, and which appear to advantage when examined with the ordinary binocular microscope. A simple method of taking stereoscopic photographs of microscopic objects was described by E. R. Turner, in the "Annual of Microscopy" for 1900. The stand used was one of the old-fashioned bar microscopes, the body tube being removed, and in place of it was fitted a pair of Stephenson's binocular prisms in a small tube to which the objective was fitted: thus the coarse adjustment was retained, and this is all that is required with low powers. Fig. 740 shows a

section of the apparatus with the camera, which is divided by a diaphragm throughout its whole length. The path of the rays from the object is shown in Fig. 741. The Stephenson's prisms being reversing prisms the pictures produced by them are reversed, and it is unnecessary to cut and transpose the photographs as in ordinary stereoscopic work. Transparencies or prints taken with this camera may be examined with the ordinary stereoscope. Drumer's stereoscopic camera (Fig. 742) consists of two bodies inclined to each other at the same angle as the

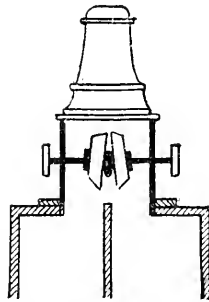

Fig. 740.—BINOCULAR PRISMS MOUNTED WITH OBJECTIVE.

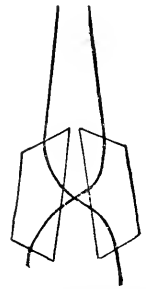

Fig. 741.—PATH OF RAYS THROUGH BINOCULAR PRISMS.

binocular microscopes: the focussing screens and plates are inserted at the top. It is provided with time and instantaneous shutters, and with an independent rack and pinion movement. Stereoscopic photomicrography is especially useful for reproducing, in their natural beauty, moderately large living objects; for instance, Hydra, Plumatella, Fredricella, Vorticella, Volvox, etc.

PHOTOMICROGRAPHY WITHOUT A MICROSCOPE.

Low power work is quite possible without any microscope at all, simply supporting the object in a suitable frame and photographing it in the ordinary way with a rather long extension camera. Another way is to use a daylight enlarging apparatus, making a small frame to fit the negative carrier and fastening the plate on the enlarging easel. The object,

placed on a suitable slide, is then inserted in the small carrier, which may conveniently be provided with spring clips and treated exactly as in ordinary enlarging. Small insects, spiders, etc., may be very effectively photographed in this manner. A lens of short focus is best for the purpose. It may be explained here that the term "low power" is commonly

really consist of a reduced photograph of minimum size in contact with a plano-convex lens of extremely small diameter and exceedingly short focus, and capable of great magnification. As the image is to be so much enlarged, it is obvious that a process giving the finest possible grain should be chosen. The most suitable, and the most generally used, is the wet collodion process.

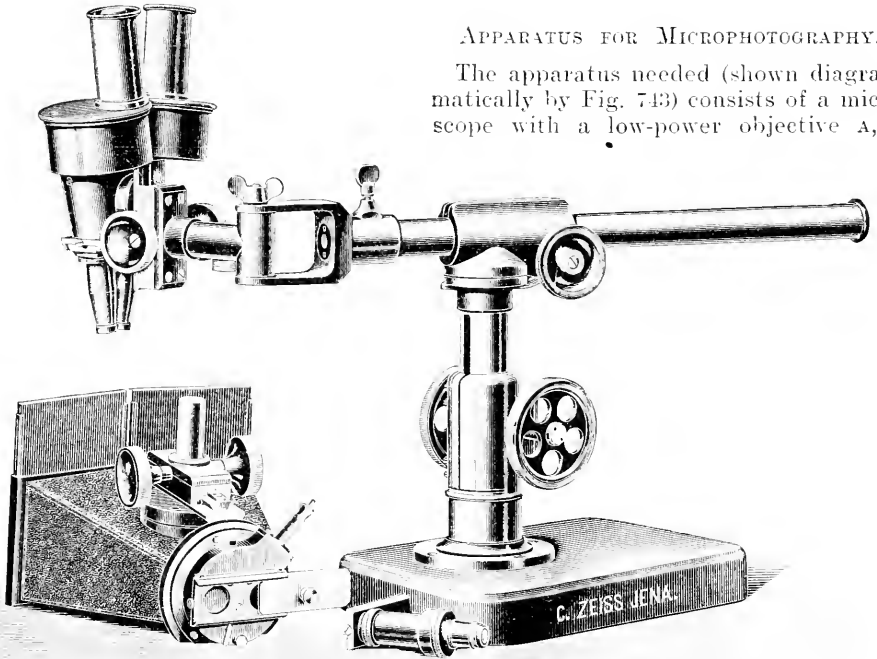

Fig. 742.—DRUNER'S STEREO-PHOTOMICROGRAPHIC CAMERA.

APPARATUS FOR MICROPHOTOGRAPHY.

The apparatus needed (shown diagrammatically by Fig. 743) consists of a microscope with a low-power objective A, a

employed for any magnification between, say, 2 and 16 diameters; from 16 up to about 550 diameters would be called "medium power"; while high power work extends from this to 1,500 diameters or more.

MICROPHOTOGRAPHY.

This term is often used synonymously with photomicrography, but, strictly speaking, should be confined to the production of extremely minute photographs, such as are often seen mounted in pen-holders and other fancy articles. They

small box B to cover in the stage and objective, and a quarter-plate or 5-in. by 4-in. camera C. An ordinary circular-wick paraffin lamp is placed at D. It is enclosed, as shown, in a tin cylinder, in which are cut two openings about 1 in. square. Over the back opening is fixed a piece of ruby glass (shown black), so that it may be used as the developing lamp; the other opening is left clear, and forms the source of illumination for the pictures. At E is placed a condenser forming a cone of rays passing through the negative F. It will be seen that the

apparatus differs only slightly from that used for ordinary photomicrography, except that the action is exactly reversed.

METHOD OF FOCUSING AND LIGHTING.

To prepare a microphotograph, a piece of wet-plate negative taken on a piece of glass of exactly the same thickness as the sensitive plate to be used is placed on the stage of the microscope. The eyepiece of the microscope is removed, and the tube, which should be carefully examined to see that it is thoroughly black inside, is pushed into the opening

for so long as the sensitive surface is upon glass of the same thickness and the objective is the same, they will remain constant for any picture. First, then, the pictures of which copies are to be taken are mounted side by side, and a quarter-plate negative made of them. This is slipped into the dark-slide—of which both shutters are drawn and the partition removed, so that it occupies the exact plane of the focussing screen—and carefully inserted in the camera. The lamp and condenser are so fixed as to form a cone of light just covering the corners of the negative and no more.

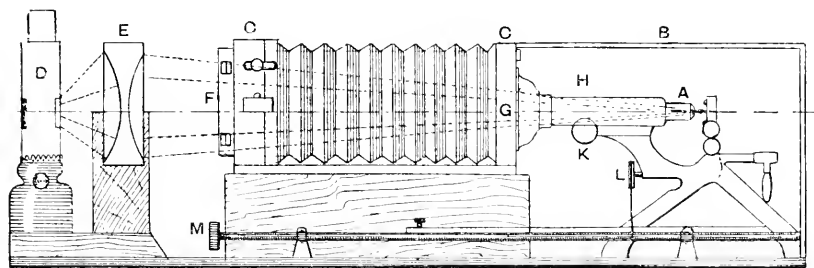

Fig. 743.—APPARATUS FOR MICROPHOTOGRAPHY.

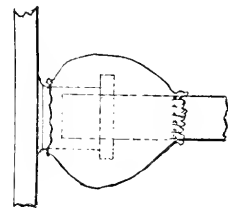

Fig. 744.—LIGHT-TIGHT CONNECTION FOR MICROSCOPE AND CAMERA.

of the camera at G. A good plan is to fit a small velvet bag, having its ends reeved up on to a loop of elastic, tightly over the end of the microscope tube *n*, and over the tube of the lens (from which the glasses have been removed), as shown by Fig. 744. This ensures a light-tight joint between the tube and the camera. Another method of connection is to use a wooden nose-piece or adapter (see Fig. 745). An enlarged image of this tiny piece of collodion negative is now carefully focussed, first with rough adjustment *k* and then with fine adjustment *L*, on the focussing screen of the camera. The fine adjustment *L* is controlled from the focussing-screen end by the thumbscrew *M*. If the negative is made to occupy the same plane as the ground side of the focussing screen, and the piece of collodion negative is replaced by a piece of sensitive plate, then on exposure a minute reproduction of the negative will be produced which will be in exact focus. The positions of the various parts may be fixed,

COATING THE PLATE AND DEVELOPMENT.

The glass used for the transparency should be of such a thickness that it is in correct focus when the lens is placed upon it. For experimental work, however, choose any thin glass free from defects and coat with iodised collodion. This collodion can be obtained ready for use of any large dealer in photographic materials, or made as directed on page 74. It should be limpid, and flow freely. If it does not, it may be made to do so by the addition of equal quantities of alcohol and ether. The plate (lattern slide cover glasses will answer for experimental work) is coated in the usual fashion (see p. 78). When it has finished draining, it is stood aside, and as soon as it has set it is plunged gently into the silver bath. The silver bath consists of 40 gr. silver nitrate, 1 oz. water, 1 gr. iodine, and 1 minim nitric acid. Development with pyrogallie acid will be found most satisfactory. The following is a

good formula for a developer suitable for use with these plates:—

Pyrogallic Acid	5 gr.
Acetic Acid	100 mm.
Alcohol	2 dr.
Water	5 oz.

The plates may then be fixed in sodium thio-sulphate 1 oz., water 5 oz., or in potassium cyanide 5 per cent solution.

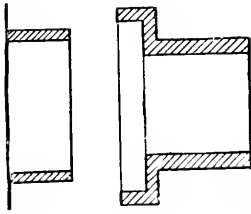

Fig. 745.—NOSEPIECE FOR CONNECTING MICROSCOPE AND CAMERA.

METHOD OF EXPOSURE.

As regards exposure, this will depend upon the light, lens, degree of reduction, and density required in the small transparency, and must be found by repeated trials. The exposure is made by withdrawing a sheet of card placed between the lamp and the negative, the space between the objective and the sensitive plate being covered in as before described. A number of pictures or groups of pictures may be included on the negative, and the reductions all made together and afterwards cut up. The transparency, which is fixed and washed in the usual way, is then mounted in contact with a very small plano-convex lens with Canada balsam. It will not be found necessary to use a dark slide for the plate; it will slide easily under the clips on the microscope stage, and, being only slightly sensitive, is not likely to be fogged during the short time it is exposed to the stray light from the lamp before covering with the box. Great care must be taken to avoid dust on the film.

MASKING THE FIELD.

In photomicrographic work some prefer to place a mask in front of the plate to limit the field; for this purpose

various-sized masks made by cutting circles in sheet zinc may be employed. There is no advantage to be obtained by having a large field unless it is covered by the object; on the other hand, there may be a disadvantage because, however carefully the interior of the camera may be blackened, some light may be reflected from it and lead to the production of slight fog on the negative. The connection between the camera and the microscope should be perfectly light tight, and yet, at the same time, it should be capable of ready connection or disconnection; this is ensured by fixing a nosepiece on the tube of the microscope. The nosepiece (Fig. 745) is simply an adapter turned in wood, the smaller tube fitting in the large tube of the microscope, and the larger tube fitting over the opening in the camera; to make quite certain that no light can enter it is covered with a small black velvet bag held by two elastic bands, which will allow quite sufficient motion for focussing the object. The interior of this adapter should be lined with black velvet glued in position.

CONCLUSION.

Having described the apparatus and methods relating to photomicrography it may be mentioned in conclusion that the work is not at all difficult, and, though a considerable number of appliances are necessarily described here, they need only to be obtained as required. The very simplest box-shaped camera may be made as a beginning, and with this and a good microscope it is possible to obtain excellent pictures. Objects should first be taken with a low power, such as an inch objective, until proficiency is obtained, the light being an oil lamp, and the bull's-eye condenser placed as described; the tongue of the blowfly shown in one of the full-page Plates being an example of work done under such conditions. Then a $\frac{1}{8}$ -in. objective with a sub-stage condenser may be tried, and diatoms, of which examples are also given, may be taken. When a considerable amount of experience has been gained, a speciality may be made of some particular kind of work.

ARCHITECTURAL AND INTERIOR PHOTOGRAPHY.

INTRODUCTORY REMARKS.

ARCHITECTURAL photography does not call, perhaps, for the same careful and deliberate selection of subject as is the case in landscape work. It demands, however,

jects. These are as indispensable here as elsewhere. The lines of the subject, and to a great extent its light and shade, are, however, practically already arranged, the architect having taken that matter into consideration in the first place. It only

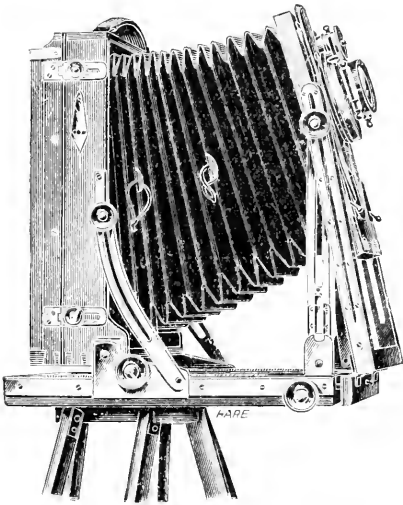

Fig. 746.—THE SANDERSON CAMERA.

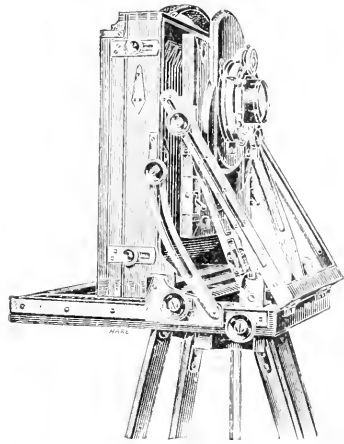

Fig. 747.—SANDERSON CAMERA ARRANGED FOR
WIDE-ANGLE WORK.

a perfect mastery of technique if the best results are desired. That is to say, the arrangement of the picture on the plate as regards the uprightiness of its lines, sharpness of detail and suitability of lighting, the correctness of the exposure, and care in printing, are all of the highest importance. Of course, it is not intended to suggest that the principles of good arrangement and composition may be ignored in dealing with architectural sub-

remains for the photographer to choose the best possible standpoint and the time when the lighting is most effective.

SPECIAL APPARATUS.

Although good work is often done with a hand camera, a stand is recommended, and for most subjects of this description is indispensable. The camera should be provided with swing back and rising front, and a sliding movement of the camera body from back to front to allow the use

of wide-angle lenses. A forward movement of the back is distinctly preferable to a backward movement of the front, since the latter often results in a portion of the baseboard projecting into the field of view and cutting off part of the picture, when using wide-angle lenses. With large cameras a movement of both front and back is advisable to secure better balance on the tripod. The "Sanderson" camera (Fig. 746), which is specially designed for architectural work, possesses many advantages. As will be seen, it permits a very large amount of rise, while the numerous fittings and adjustments

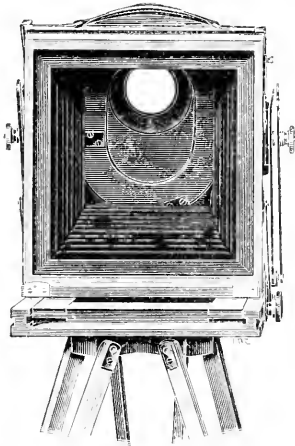

Fig. 748.—INTERIOR VIEW OF SANDERSON CAMERA.

allow for every possible movement between the lens and the plate. Fig. 747 shows the camera arranged for wide-angle work, and gives a good idea of its remarkable ingenuity and convenience of construction. This camera is now fitted with a new patent body, which effectually prevents the bellows from "sagging" and cutting off part of the image when the front is much raised; the principle of this contrivance will be understood by the interior view (Fig. 748). Another excellent camera for the purpose is Lizars' "De Luxe," one pattern of which is shown by Fig. 749.

LEVELS.

Many cameras are now provided with spirit levels and plumb indicators. Where

this is not the case, these should be purchased and carefully screwed on, using every precaution that they are accurately adjusted. Unless this is done the results obtained will be misleading, and a serious hindrance to exact work. Various patterns of levels and plumb indicators are shown by Figs. 750 to 755 inclusive. After fixing these, the apparatus should be tested, since even so slight a matter as an imperfectly fitting screw may cause incorrect readings. When special work has to be accomplished, and the necessary appliances are not at hand, the top of the camera may be levelled by placing on it a small bullet or marble, and adjusting the apparatus until the former remains

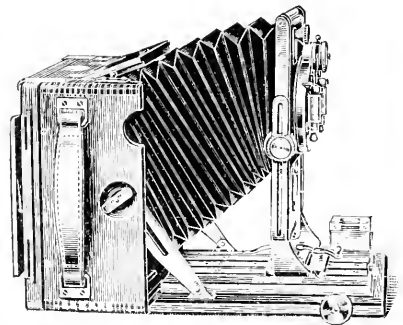

Fig. 749.—LIZARS' "MINOR DE LUXE" CAMERA.

motionless. The back may be levelled by means of a piece of string, to one end of which is tied a stone or other convenient weight.

BEST POSITION FOR LEVEL.

The position of the level is important. It is useless to attach it to any portion of the camera which it may afterwards be necessary to tilt. The best position, as a rule, is in the centre of the rear of the baseboard. The base is first levelled and then the other frames kept at right angles to it, unless there is any reason for doing otherwise. If the level is placed on the top of the back frame it is in a less convenient position for viewing, and it is necessary to make sure, first of all, that the frame is exactly at right angles to the base; otherwise, although levelled or

vertical, it may not be parallel with the lens-board or object. This remark applies more particularly to those cameras which are fitted with a swing-back movement turning from the base, but as the majority of cameras used for the work under consideration are designed on this principle, it is worthy of attention.

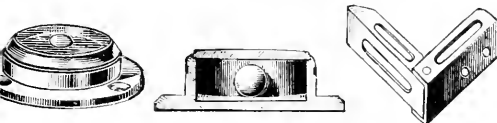

Fig. 750. Fig. 751. Fig. 752.

Fig. 750.—CIRCULAR SPIRIT LEVEL. Fig. 751.—BALL LEVEL. Fig. 752.—TWO WAY FOLDING SPIRIT LEVEL.

CHOICE OF LENS.

The modern photographic lens has been brought to such perfection that it would be very difficult to point to any particular type—excepting the portrait lens, which would be unsuitable for this purpose. Flatness of field and good covering power are the qualities which are especially valuable in architectural work. Any good rectilinear doublet will do for in-

reduced to an absurd degree. But on the other hand, if it is intended to secure a bit of architectural detail in such a position that the camera must be close to it, the long focus lens would be quite useless, and must be replaced by one of wide angle. A lens of the portable symmetrical type is the best kind to employ for this purpose. It has splendid covering power, and gives exquisite definition, but will require to be stopped down, and necessitates a liberal exposure. Its use is always indicated in cramped situations, whether they be inside a building or outside. The Voigtländer Wide-Angle Euryscope (Fig. 756) may be here mentioned as admirably adapted for most classes of architectural work. It, of course, goes without saying that, where expense is no object, an anastigmat is to be preferred.

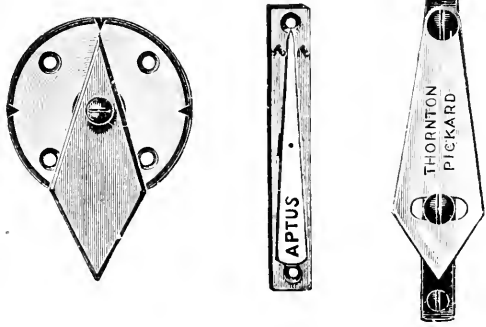

Fig. 753. Fig. 754. Fig. 755.

Fig. 753.—REVERSING PLUMB INDICATOR. Fig. 754.—PLUMB INDICATOR. Fig. 755.—THORNTON-PICKARD PLUMB INDICATOR.

teriors, but its focal length must be chosen with due regard to the size of the building for which it is used. The nave of a cathedral, for example, would require a long focus lens, otherwise its distant choir and east window would be

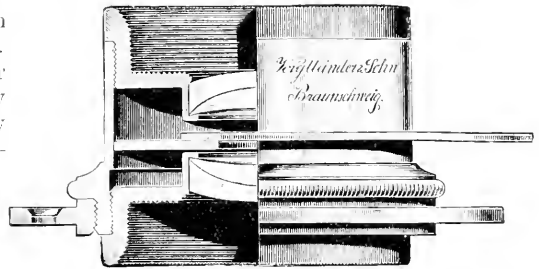

Fig. 756.—VOIGTLÄNDER'S WIDE-ANGLE EURYSCOPE.

LONG v. SHORT FOCUS LENSES.

When only a portion of architectural detail is required and one is not obliged to get close to the subject, the long focus lens would certainly be preferable. The general rule is to use as long a focus lens as possible, resorting only to the wide angle when the subject includes a great deal and the camera cannot be placed sufficiently far away. It is generally acknowledged that the perspective is best when the focal length of the lens used is about equal to the diagonal of the plate. It must be remembered that wherever long or short focus lenses are referred to it is their proportion to the diagonal of plate which is meant. The apparent distortion arising from the use of a short focus lens exists only in the

margins or outer portions of the picture, although the perspective of the centre portion may be spoilt by contrast with the surroundings. When, however, the picture is trimmed down to such dimensions that its diagonal equals the focus of the lens employed, the perspective is the same as if a longer focus lens had been used, although the image is on a smaller scale.

FINDING NECESSARY ANGLE OF VIEW.

Properly speaking, the point of view and size of the picture should be chosen without reference to the lens. If the image on the screen is found to be too large or too small from the desired standpoint, a lens of different focus should be employed. Obviously, therefore, it is desirable to carry several lenses, or a set of convertible combinations. Much trouble in setting up the camera and choosing the most suitable lens will be saved by the use of a view meter graduated for various foci; these are fully described and their use explained in the section dealing with "Landscape Photography." Where only one lens is available, more attention must be paid to ascertaining the best possible position for the camera. It is better to alter the size of the picture than to introduce false perspective. It should be remembered that any non-distorting lens will give truthful perspective when the resulting picture is viewed from a distance equal to that of the lens from the plate when taking it, although the effect will very likely seem wrong when looked at from the ordinary viewing distance, which is commonly further off. This explains why it is advisable to retreat somewhat from the focussing screen before finally deciding on exposure.

LIGHTING.

The subject of lighting is of great importance. As a rule, a side light just in front of the building is to be preferred—that light, in fact, which will give the best appearance of relief while also preventing heavy shadows. This statement may, however, require modification under

different circumstances, for it may be said that each subject will require its own special treatment. Direct sunlight is generally undesirable. It is advisable to critically study the building from various aspects and carefully calculate the times when each portion is likely to receive its best lighting. The method of doing this is dealt with in the section on "Landscape Photography." It will then be possible, if more than one picture is required, to take each view in rotation as the light on each becomes suitable. The photographer must make up his mind, sometimes, to do a considerable amount of waiting, for hours will often elapse before a certain desired light becomes accessible. The lighting of interiors is treated separately in another part of this section.

OUTDOOR EXPOSURES.

These will vary so much that it is impossible to give any exact directions. With a new, white building about half that required for a landscape view at the same time, and under identical conditions as to plate, stop, etc., will prove sufficient; while subjects blackened with age or containing red brick will require longer. It is always advisable to use an exposure meter and, if the subject cannot conveniently be taken again, to expose several plates, giving different exposures to each. This greatly diminishes the chances of failure. When some experience has been gained, the operator will be able, aided by the actinometer, to estimate very accurately the required exposure for any given subject. It must not be forgotten that the amount of contrast present, which, of course, is affected largely by the time of day and the particular lighting chosen, should be allowed for in the exposure. A comparatively flat or very well-lighted building should be given a minimum exposure, while one possessing much contrast of light and shade, a high degree of relief, or heavy shadows, should be allowed a longer time than usual. A backed or multiple-coated plate should always be used. A sky-shade may be necessary to keep direct light from entering the lens.

PHOTOGRAPHING INTERIORS.

For photographs of the interior of rooms, churches, and other buildings, a rapid backed plate should be employed. Plates can now be procured from the dealers ready backed, and it is far better to use the commercial article than to trust to a plate backed by an inexperienced hand, for if the backing medium is not laid on evenly but in streaks, such streaks are apt to render their presence evident on the film side when the plate comes to be developed. This may arise from internal reflection, or from access of an excessively bright red or orange light when the plate is handled in the dark room, the operator relying too confidently on the ability of the pigmented back to repel the light. Whatever be the cause, such streaks certainly do make themselves apparent. Those, however, who prefer to do their own backing will find the Avery backing tray, shown by Fig. 757, very convenient. The plate is laid film down in the trough, the hinged frame lowered and pressed lightly to keep it in position, while the backing is applied in the usual manner. If films be used, there is practically no need for backing. This is also the case with multiple-coated plates, such as the Sandell. The lens employed for this class of work should possess good covering power, and as a general rule a small stop should be used, for good definition in every part of the picture is most essential.

THE THEORY OF HALATION.

Halation consists of a kind of halo, giving rise to indistinctness around the image of a bright light or object in a photographic negative. It is generally caused by reflection of oblique rays of light from the back surface of the glass. Rays which strike the plate exactly at right angles to its surface will simply pass through the glass, causing no reflection; while rays which are slightly slanting will partly pass through, only a certain proportion being reflected. As the degree of obliquity increases, however, the amount of reflection will also increase, until at a particular angle, varying with the refrac-

tive index of the glass, the whole of the light is reflected. The obvious remedy is to coat the back of the plate with a suitable backing mixture, which will serve not only to prevent reflection, but to absorb the stray light. The backing must be in optical contact with the glass, and, preferably, not absolutely opaque, so that the light rays are permitted to travel into it and become absorbed. It seems at present to be generally agreed that, to be perfectly effective, the backing should possess the same refractive index as the glass. An effect resembling halation is

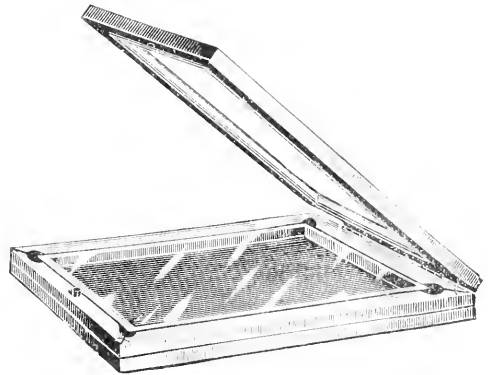

Fig. 757.—THE "AVERY" BACKING TRAY.

sometimes caused by light spreading sideways in the film itself. For this there is no remedy, but fortunately it is seldom objectionably apparent.

METHODS OF BACKING PLATES.

A good plate backing, easily applied with a soft brush, sponge, or piece of cotton-wool, consists of—

Burnt Sienna	1 oz.
Caramel	$\frac{1}{2}$ oz.
Gum Mucilage	$\frac{1}{2}$ oz.

These ingredients are thoroughly ground together, 1 oz. of methylated spirit being finally added. The mixture soon dries, and is readily removed before development with a damp sponge. A rather thin solution of bitumen in benzene is also very suitable. This is removed by rubbing

with a sponge wetted with turpentine or benzene. Another excellent formula is—

Burnt Sienna	$\frac{1}{2}$ oz.
Gum	$\frac{3}{4}$ oz.
Glycerine	1 dr.
Water	5 oz.

For orthochromatic plates used with a screen it is evident that a red or yellow backing, particularly the latter, is inadmissible. In such a case a black

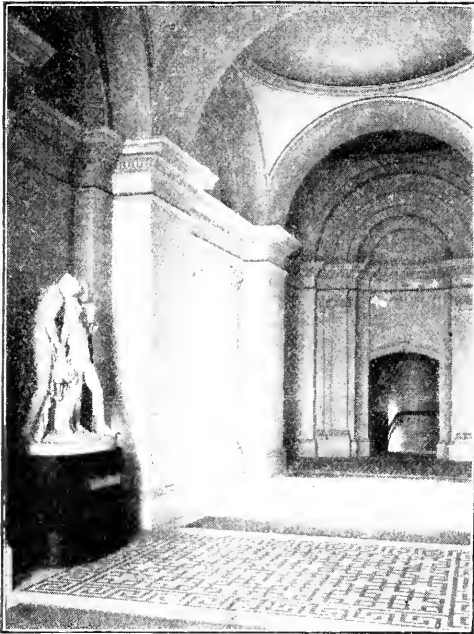

Fig. 758.—INTERIOR: TATE GALLERY.

backing will be found most suitable. Bates's black varnish or Brunswick black might be employed, or even black cloth or paper squeezed into optical contact with the back of the plate, first smearing it with glycerine.

EXPOSURE FOR INTERIORS.

It is quite impossible to give any golden rule with regard to exposure. Using $f/32$, the average exposure for a church interior will be about twenty minutes with a fairly rapid plate. On the other hand, in a

well-lighted building with light coloured walls and with no stained glass in the windows, five minutes will give a fully-exposed picture. The photographer must exercise his judgment in this matter, for very often circumstances will not permit the use of an exposure meter. The experienced man can get a very fair idea of the exposure necessary by viewing the picture on the ground glass screen of the camera, provided that the light is good enough to afford a recognisable image. But in many cases no information can be obtained from this source, the light being too feeble to show up anything but the brighter details of the picture. The worker is then like a man groping in the dark, and must feel his way as best he can. Plate No. 37 and Figs. 758 and 759 are good examples of interior photography.

USING METER IN DARK INTERIORS.

In the majority of interiors, however, the meter may be used by remembering that the first distinguishable effect on the paper takes place in approximately one-sixteenth of the whole time. It is then merely necessary to place the meter in the position in which detail is required, in the shadow portion, and to note the time of darkening to the first distinguishable tint. The exposure will then be sixteen times the time occupied in reaching the first tint. The plate and meter may be exposed simultaneously with a view to saving time. In the case of an extremely dark interior the meter may even be exposed near the source of illumination, as a very rough guide which, coupled with experience, will form a useful aid, but exposing in the position of the half-tones gives a better clue.

DEVELOPMENT.

Much depends upon the careful and patient development of an interior negative. It should be constantly borne in mind that the contrasts are excessive, and that every endeavour must be made to get the most out of the shadows, while, at the same time, keeping the well-lighted portions of the plate back. The problem

is not an easy one to solve, and the best plan is to deal with the matter tentatively, determining to spend time and exercise patience over an operation which in most cases is bound to be protracted. Of course, in the case of a well-lighted grey building, it is possible to develop in the ordinary manner, employing the solutions at their usual strength. But with a difficult interior one can hardly be too careful. Take, for example, a standard pyro-soda developer, which is known by experience to work well with the plates to be used. Let this same developer be employed for a difficult interior, but halve the amount of soda and increase the amount of water six times. Flood this over the plate, and if nothing appears at the end of five minutes add a little mixed developer of the normal strength. An attempt should be made to get all details out with the weakest possible solution, and then just at the last—it may be after twenty or thirty minutes—if the plate is lacking in density, the stronger solution is used for a few final seconds. It is advisable always to stop development before the high lights are clogged. This will probably mean that the shadow portions are very thin. If such is the case, the negative should be backed with *papier minéral*, cutting this away from behind the dense portions.

ADVANTAGES OF RAPID PLATES.

The worker has already been advised to employ a plate of the rapid variety. This is not so much to save time in exposure as to secure good quality in the negative. There is a golden rule in photography which directs one to "expose for the shadows," and this is especially important in dealing with interiors. It must be realised that a subject is being attempted some parts of which need a hundred times more exposure than other parts, owing to the paucity of the light which illuminates them. A slow plate is not capable of readily recording detail in the heavy shadows, while it possesses the property, more than a rapid one, of giving great density in the well-lighted portions. In this way strong contrasts,

giving a very patchy and unsatisfactory picture, are almost unavoidable.

STAINED GLASS.

Where an ecclesiastical building is wholly lighted by stained glass windows the exposure required will be very protracted. But there is here a compensating advantage found in the circumstance that such windows, although they may



Fig. 759.—INTERIOR: TATE GALLERY.

face directly towards the camera, are, unless a quantity of colourless glass be mingled with the stained variety, perfectly free from halation. This has been proved again and again by purposely using unbacked plates upon such subjects, but, in such cases, care has been taken to employ plates which are thickly coated. Some years ago very sparsely coated plates were in the market, but all the best brands, nowadays, may be depended upon for good coating. It has been a case of the survival of the fittest, and the modern worker has the advantage of avoiding

many of the pitfalls which were common to photographers when the gelatine dry plate first came into use. In photographing a building lighted by stained glass windows, isochromatic plates can be employed with advantage, no screen being necessary.

USE OF FLASHLIGHT.

It has been suggested by some writers that in order to obviate the difficulties which occur in taking a dark interior, the place should be illuminated with some sort of flashlight at the moment of taking the picture. This may be the only way with certain subjects, but care must be taken that no risk is run of spoiling the pictorial effect. If the picture is wanted merely as a draughtsman's record of the wall paper, or other decoration, the flashlight may be used without hesitation, but if an artistic picture is desired the subject must be given a long exposure under its normal lighting. Sometimes the flashlight can be used as an adventitious aid when contrasts are very severe, and it is essential to bring out the detail in some dark corner; but, even in this case, the employment of a few inches of magnesium ribbon, burnt behind some shield, so that the direct rays cannot get near the lens, is to be preferred.

NOVEL TREATMENT OF A WINDOW.

In an interesting case, recently recorded, it was desired that the landscape outside a large window, which formed a prominent part of the picture, should appear in the photograph. At first the photographer considered that this could only be done by employing two negatives, but it was finally determined to get over the difficulty by the use of the flashlight, obtaining both landscape and interior on one negative, and thus saving labour in printing. Using a small stop the landscape was first secured, the afternoon light being chosen as most effective for the particular case in hand. Then the lens was left capped until night, when, by means of a powerful flashlight, the image of the interior of the room was obtained. It is obvious that if such a plan be re-

sorted to there is great risk of false lighting in the resulting negative, but the method may be mentioned as one which can be made use of when other means fail.

THE TRIPOD STAND.

In places with tiled or polished floors there is always a difficulty in persuading the legs of the tripod to remain in one position, and the photographer should provide himself with pierced discs of cork or indiarubber, in which to insert the pointed feet. If a square of carpet can be borrowed, the corks can be dispensed with. In the absence of both corks and carpet, the legs of the tripod may be held at a convenient distance apart by tying them together with a good strong cord. The camera must be kept level, or if tipped at an angle, the swing back must be employed to make the upright lines of the picture vertical on the ground glass. It is far preferable to use the rising front, and, if that does not meet requirements, the whole apparatus may be raised by the use of chairs. In churches where there is a gallery, the best standpoint will often be found there. Sometimes an excellent view can be obtained from the reading desk or the pulpit. Perhaps the worst place for the camera is in the centre of the aisle. The experienced worker will spend some little time in examining the building from all points before he decides upon the spot from which to make the exposure.

BLOCKING WINDOWS.

Even with a backed plate, a window through which much light comes will show a fog round its edges, due to halation; there is also the danger of a ghost image. This is caused, among other ways, by the bright image of the window on the surface of the sensitive plate being reflected upon the back surface of the lens, and from thence upon another part of the plate, so that in the resulting negative the window appears where it ought, and a duplicate of it where it ought not to be. An excellent result can be secured, where facilities can be obtained, by covering a refractory

window on the outside with a tarpaulin for the major part of the exposure. In such a case three or four seconds' exposure is given for the window, and perhaps twenty minutes for the remainder of the picture after the window has been covered.

FOCUSSING.

In very dark interiors it is sometimes impossible to make out any details on the ground glass. In such a case, an assistant with a lighted taper, who is directed to move from place to place in the picture, is indispensable—but, happily, such dark places are not very often met with. Under such conditions it is practically impossible to over-expose a plate. In using a wide-angle lens, which is a necessity where the space is confined, one or two precautions must be taken. No object, such as a font for instance, must be very near the camera, or its image on the plate will be terribly distorted, and care must be taken, if the bellows are of the Kinnear or pyramidal form, that none of its folds impede the rays from the lens. In some makes of cameras there is also a danger of the baseboard protruding in front being pictured on the negative. Such things are likely to be overlooked in the dim light available, and do not become apparent until too late, when the plate is developed.

FIGURES.

In photographing churches where a long exposure is called for, visitors or others moving about can be wholly ignored; but, of course, anyone in light-coloured costume who stood near the camera for any length of time would injuriously affect the picture, by causing a ghostly form on the negative. If such an intruder cannot be asked to move away, the lens should be capped until the coast is clear. Sitting or kneeling figures which remain in one position, add to the effect of the picture. In quiet Continental churches, which are open all day to worshippers, such figures can sometimes be secured without trouble. It may be mentioned here that in foreign churches a camera can generally be used without any

interference on the part of the authorities, although if a series of pictures is wanted of any particular building it is best to first obtain permission. As a rule, pictures of side chapels, monuments, and details of buildings give far more artistic results than general views.

LIGHTING OF INTERIORS.

The lighting of an interior subject is all important. If the windows are at one side, and face the north, the lighting will be practically the same at all hours of the day, and the worker will not be troubled with direct sunlight. But in the case of a church with the windows on all sides, unless these are of stained glass, there will be splashes of light about which are difficult to deal with. In such a case the worker must adopt the same precautions as would be taken in photographing a woodland glade with trees arching overhead—that is, a sunless day must be chosen for the work. Otherwise, and in either case, the contrasts between the light and shadows will be so great that the print will have that character known to experienced workers as "soot and whitewash." And let it be here noted that strongly-lighted white glass windows give rise to another difficulty, which is a kind of spurious halation. The light from such windows lights up the motes in the atmosphere, which are nearly always present, and the picture is marred by a mist, the origin of which is seldom attributed to the right cause.

DARK ROOM PRECAUTIONS.

In cases of protracted development, such as that which has been already considered, the greatest care must be exercised in the dark room with regard to the non-actinic light employed. And especially is this the case if an isochromatic plate be used. Sufficient developer should be taken to well cover the surface of the plate. It is a most vexing thing, after having used every precaution to secure a good negative, to find that, in the dim light of the dark room, part of the surface has been left untouched by the developer

until it is too late to remedy the fault. After the liquid has been swilled over the plate a flat camel-hair brush should be passed in both directions across the surface and the dish covered with a cardboard shield. The dish should be rocked every few minutes, and the operator should not be tempted to remove the cover more than necessary. Plenty of time should be taken over the operation, and it should be remembered that it will save much after-trouble if a negative can be secured which will not require doctoring before a decent print can be obtained from it.

DOMESTIC INTERIORS.

In photographing ordinary rooms, shadows can be made less dense and figures can be introduced without the strain of a long exposure, by the judicious use of a flashlight. It is in such rooms that one must guard against the violent perspective produced by the incorrect employment of the wide-angle lens. It is most difficult in a small room to choose a suitable place for the camera without getting exaggerated perspective into the picture. The only thing to do is to use a lens with as narrow an angle as possible, and to clear away chairs and other objects near to it. A bare space in the foreground of a picture gives the subject a dignity which it would not otherwise possess. Another precaution must be taken in rooms where the ceiling is low—the tripod must not be used at its full height. In cases where the place to be photographed is well lighted all difficulties are greatly reduced, because the operator can see how the picture looks upon the ground glass screen of the camera. In any event, it is worth while to pin back curtains and raise blinds to their fullest extent before focussing, so as to get as much light on the room as possible.

PHOTOGRAPHY OF MINES.

For this kind of work a magnesium torch or lamp should be employed, and lenses of large aperture. Attention

should be paid to the surfaces of the lens, which are very liable to be covered with moisture. In many cases, more than one lamp will be necessary. Focussing should be done on candles or safety-lamps, and care should be taken that nothing at all liable to cause an explosion is attempted. Where electricity is available high-power arc lamps may be used advantageously. Negatives of such subjects require very patient development, and generally have to be intensified. Flash-light mixtures should never be used without first making sure of the entire absence of dangerous gases. For photographing tunnels, caves, etc., of an ordinary description, the magnesium flashlight may safely be used, unless there are any loose fragments of rock liable to dislodgment by even a slight concussion. The presence of sufficient ventilation should be ascertained or the smoke of the flash powder may prove very objectionable.

FACTORIES AND SIMILAR BUILDINGS.

Such subjects as these seldom present much difficulty, and may be treated in just the same way as any other interior. Where figures are present, all the light available should be obtained by pulling up blinds and removing obstructions, since in this case a short exposure is required. If, however, there are many large windows, this may not be necessary, and an effort should be made to soften and direct the light to obtain the best effect. All possible preparations must be made beforehand, so that as little delay as possible may be caused. A lens of large aperture, preferably an anastigmat, is recommended.

SUBMARINE PHOTOGRAPHY.

Where the water is comparatively clear, good photographs may commonly be obtained by pointing the camera down from a height above the surface, as, for example, from the car of a balloon. An automatic camera attached to a kite is also sometimes used. A device was intro-



TAKEN WITHOUT SCREEN



TAKEN WITH SCREEN

FLOWER STUDY

duced a short time ago in which a specially designed camera with an electric lamp on top could be lowered into the water, a series of exposures being made by the light of the lamp. If photography is to be undertaken by divers, a weighted stand camera of specially waterproof construction should be employed. The focus and other matters should be settled by easily accessible scales, and a direct-vision view-finder fitted. It is difficult to give any details as to the exposure. In some cases the daylight will be sufficient, with a comparatively short exposure; in others a protected arc or magnesium lamp will have to be lowered down and suitably adjusted. Needless to say, only the most rapid plates and lenses should be used. Slow development with a dilute solution will probably be advisable.

CONCLUDING HINTS.

There seems a very prevalent idea that architectural work necessitates large apparatus. This is not necessarily the case, for, if due attention is given to securing fine detail, such subjects lend themselves admirably to enlargement. As a rule, a smooth surfaced paper will give the best result, unless an impressionistic effect is desired, and a warm tone is generally to be preferred. The platinotype and carbon processes are peculiarly suitable; bromide prints toned in the hypo-alum bath are also extremely effective. Care is necessary, in trimming and mounting, that the uprightness of vertical lines is maintained, or all the trouble taken in this respect when obtaining the negative will be thrown away.

SPECTROPHOTOGRAPHY.

INTRODUCTION.

It has already been pointed out that white light is a composite colour. Consider, however, a ray of some pure colour such as that given by a sodium flame. When this monochromatic ray is incident on the surface of any transparent substance in a direction other than at right angles, it is refracted from its original path, the amount of deviation depending on its wave-length. The diagram of the

trum, will be seen in the middle of the cardboard instead of a line of white light. The end of the spectrum farthest from the original position of the slit will be violet.

VIRTUAL SPECTRUM.

The spectrum seen is a continuous one, because white light consists of rays of infinite gradations of colour, the chief colours being in the following order: red, orange, yellow, green, blue, indigo, violet. The spectrum is called virtual because it

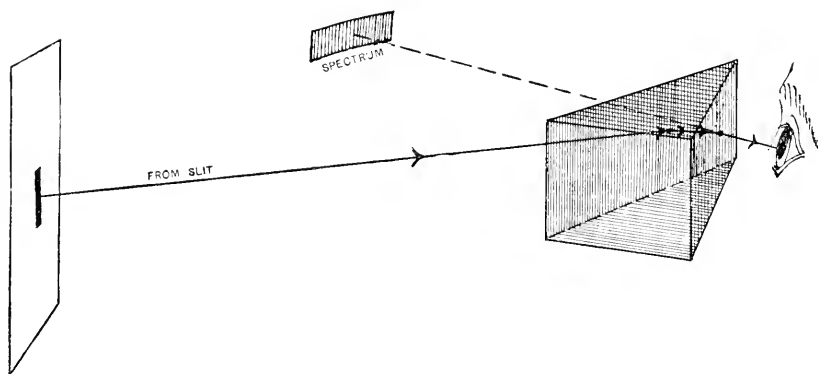

Fig. 760.—SIMPLE VIRTUAL SPECTRUM.

virtual spectrum (Plate 36) shows how a ray is refracted at a glass surface, and also at an air surface. Violet is the colour which shows most deviation. This is easily demonstrated. Take a piece of cardboard or block tin in which a narrow slit has been punched by a $\frac{3}{4}$ -in. wood chisel, as shown by Fig. 760. Hold this up at arm's length, letting the light from a bright cloud or coal-gas flame pass through the slit. Look at the slit through a glass prism, with its refracting edge parallel to the slit length, and a coloured band of light, called a spec-

has no real existence; the eye merely imagines it. To get a definite idea of the dispersion of the rays, consult Plate 36 again. A ray of white light coming from a slit o is incident on the surface of a prism, and there begins to disperse. Three rays out of the various colours have been chosen for illustration. On entering the denser substance, the rays are bent towards the normal, $N_1 N_1$; but on emerging from the glass into the air they are bent away from the normal, $N_2 N_2$. The separation of the colours has, however, been

exaggerated. The diagram shows that the white slit at o is replaced by a number of coloured slit images, o_r , o_b , o_g , arranged side by side, since the eye sees a certain coloured slit, in the direction in which that coloured ray is travelling, when it meets the eye. But the rays which start from o are in reality narrow cones, and not lines. This conical shape enables the eye to judge the distance of the source; and, therefore, the apparent length from o to the eye (taking the red ray for an example) will be practically equal to the distance actually traversed by the light from the slit, as the prism does not appreciably disperse such small cones, consisting of one colour.

MINIMUM DEVIATION.

Some standard position of the prism must be selected, in order that experiments may be repeated or compared by different observers. If a ray of light passes through a prism so that on entering and leaving it makes equal angles with the refracting surfaces, it has on emergence the least deviation from its original path. This position has been chosen for the yellow ray in the diagram of the virtual spectrum. It will be seen that the prism can only be accurately so placed for rays of one colour. This is a decided weakness, and one that cannot be avoided when using prisms. When photographing the spectrum as a whole, a convenient method is to adjust the yellow part of the spectrum to this standard position, because a very pure monochromatic yellow light can be obtained by means of a sodium flame. The other colours are then approximately in minimum deviation.

REAL SPECTRUM AND SPECTROMETER.

To get a spectrum that can be photographed, the rays must be intercepted by a convex lens as they emerge from the prism, and brought to a convenient focus. The most accurate way of accomplishing this is that adopted in the spectrometer. The second diagram on Plate 36 explains the principle of this instrument. Ordinary

white light is allowed to enter a slit of adjustable width at o . The slit is formed by two steel jaws, and is opened by means of a small graduated side screw. Its distance from the lens L_1 can also be varied, and it is put exactly one focal length away. The entering light diverges from o , which is now considered to be a source of light, falls on the lens L_1 , and is consequently made to travel along parallel paths until it strikes the first face of the prism P . This prism, which is of very dense glass, and therefore of high refractive index, is put in minimum deviation for the required colour, and breaks up the rays in the manner already explained. It is most important, however, to notice that all the rays of one colour travel in parallel paths through the prism, and are still parallel on emerging. If the incident rays are not

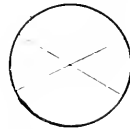

Fig. 761.—CROSS WIRES IN SPECTROMETER EYEPIECE.

parallel this will not be the case. The lens L_2 , which is the field glass of a telescope, will therefore bring all the rays to a focus at a focal length distance from itself.

THE IMAGE.

Each colour will give a separate image, thus making a band of colour, which is a series of real images of the slit, and the colours are those of which the original light is composed. If a piece of ruby glass is interposed between the gas flame and the slit, only red rays can enter, and the spectrum will show only a red band. In this way, the prism analyses any source of light. This spectrum is real, and would act on a sensitive plate; but it is very small. In the spectrometer it is viewed by an eyepiece which gives an enlarged virtual image of it. There are two fine cross wires in the eyepiece which should be set on the real spectrum, as shown in Fig. 761. The intersection of the wires can be set on any particular colour by

moving the telescope. The tube with the slit and lens L_1 is called a collimator.

ADJUSTMENT OF SPECTROMETER.

Take out and focus the telescope on a very distant object. This prepares it for receiving parallel rays, and its adjustment must not afterwards be altered. Now remove the prism temporarily, and illuminate the slit o with a sodium flame. This is made by placing a ring of moderately

goes away, turn the table in the opposite direction. A position will be found in which the telescope is as near as possible to the produced axis of the collimator. Any motion of the prism then causes a greater deviation. Clamp the telescope, and take a second reading of the vernier.

DISTINCTNESS OF IMAGE.

The slit must be narrowed until the image is only a fine line, or, in the best

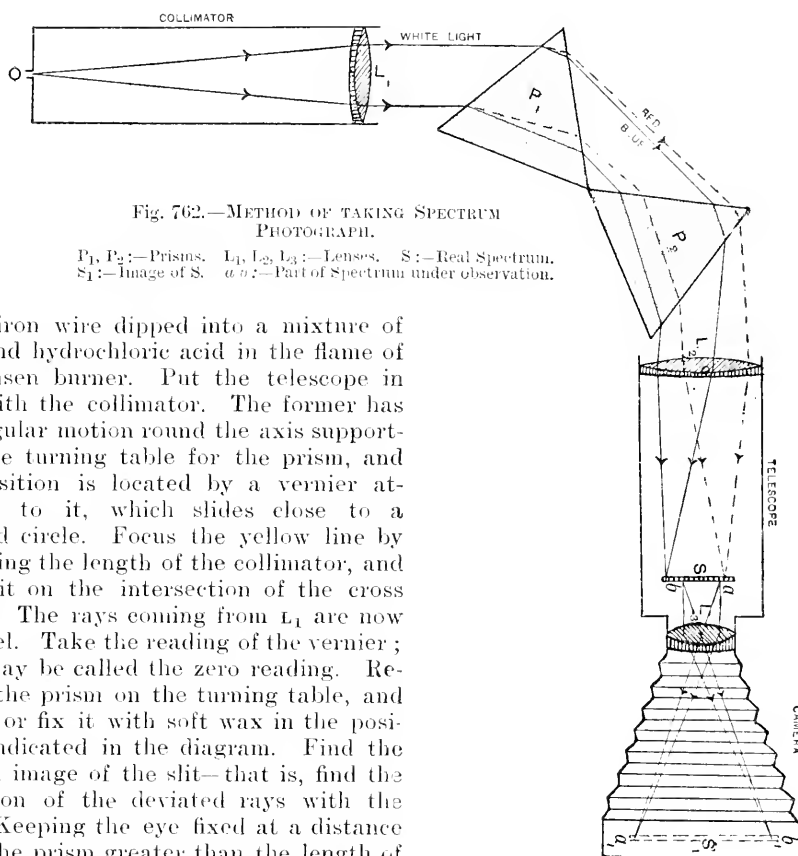

Fig. 762.—METHOD OF TAKING SPECTRUM PHOTOGRAPH.

P_1, P_2 :—Prisms. L_1, L_2, L_3 :—Lenses. S :—Real Spectrum.
 S_1 :—Image of S . aa :—Part of Spectrum under observation.

thick iron wire dipped into a mixture of salt and hydrochloric acid in the flame of a Bunsen burner. Put the telescope in line with the collimator. The former has an angular motion round the axis supporting the turning table for the prism, and its position is located by a vernier attached to it, which slides close to a divided circle. Focus the yellow line by adjusting the length of the collimator, and place it on the intersection of the cross wires. The rays coming from L_1 are now parallel. Take the reading of the vernier; this may be called the zero reading. Replace the prism on the turning table, and clamp or fix it with soft wax in the position indicated in the diagram. Find the virtual image of the slit—that is, find the direction of the deviated rays with the eye. Keeping the eye fixed at a distance from the prism greater than the length of the telescope, bring the latter round to a position in front of the eye. On looking through the eyepiece the slit will again be seen. Rotate the turning table through a small angle, and follow the image with the cross wires. If the telescope comes nearer the zero reading, continue; if it

spectrometers, a very fine pair of lines side by side. Replace the sodium flame by a batswing burner, or, better still, an oxy-coal-gas limelight, and a continuous spectrum will be seen. An incandescent gas burner would be better than the bats-

wing. The narrow slit means a loss of light, but it provides a purer spectrum, in which the colours do not overlap. It is impossible, of course, to obviate overlapping entirely.

DEVIATION AND WAVE-LENGTH.

The angle between the first and second readings of the telescope vernier is the angle of minimum deviation. In accurate work this adjustment must be made for every colour observed. Some spectra consist only of a few lines. Hydrogen at atmospheric pressure, for example, gives four: one each in the red, blue and violet, and one in the extreme violet. For tabulation, lines at distances apart corresponding to the angles between them are placed between two long parallel lines, which represent the full length of the continuous spectrum. The deviation depends on the wave-length, or, as it is generally expressed, on the colour, though the latter term is not so accurate. The material of the prism is a factor to be considered, and unfortunately there is no simple law connecting the deviations and wave-lengths for any two prisms. The deviation for the same wave-length varies with the kind of refracting substance used. Comparison methods are therefore employed.

TAKING A SPECTRUM PHOTOGRAPH.

A simple photograph may be obtained by the method illustrated in Fig. 762, regarding the real spectrum at s as the object to be photographed; ab are the parts of the spectrum under observation, and s is the image of the spectrum. A quarter-plate camera will be large enough for the first trial, and s may be focussed on the ground glass, either by means of the eyepiece L_3 , removing the camera lens, or *vice versa*. In any case, see that the junction between the camera and the telescope tube is light-tight, and cover over the space between the lenses L_1 and L_2 with a thick black cloth. Focus first with a bright sodium light. Replace this by a limelight or an electric arc, and bring the part of

the spectrum required on to the glass without altering the distance from L_3 . The spectrum may be an inch or more in length, from red to violet. The width is of no consequence, and is generally kept small to prevent distortion of the lines. To get a satisfactory spectrum, however, the colours must be more dispersed. Additional prisms, which must all be in minimum deviation, are therefore introduced. In Fig. 762 two prisms $p_1 p_2$ are shown. Automatically acting tables are obtainable for keeping the prisms symmetrically apart, however the telescope may be moved. Without these, each prism has to be adjusted separately, beginning with the one nearest the collimator. As may be imagined, this multiplication of prisms means a large loss of light by reflection; the source of light, therefore, must be good. The room should be darkened, the plate inserted in the camera in the usual way, and the exposure found by trial. For a small spectrum there will be an approximate focus all along the plate, but if only part of the spectrum be taken and the image consequently enlarged, the focussing screen should be slewed somewhat towards the violet, as the focal length of the lens for that colour will be shorter.

KIND OF PLATES: INFRA-RED ACTIVITY.

As the continuous spectrum is rich in red and yellow rays, the plates must be made sensitive to the red radiation whenever the whole visible spectrum is to be photographed. Sir Wm. Abney has devised a bromo-silver emulsion which is very sensitive to long-wave radiation. The spectrum produced by photographic negatives is more extended than that seen by the eye, the violet end of the spectrum being much more actinic than the red. The eye sees the spectrum finishing at the violet, but that does not prove that there are not other more refrangible rays. That there are many more is attested by every sensitised plate, and these are called "ultra-violet" rays. In the same way the bromo-silver emulsion reveals radiation in the red below the extreme point seen by the eye, and these rays are termed

"infra-red." Abney prepared plates so sensitive that a photograph of a kettle was obtained by means of the radiation from the boiling water inside. This infra-red portion can be observed otherwise than photographically.

light reflected from the galvanometer mirror on to a travelling sensitised strip wound on a drum by means of clockwork. The presence of radiation bands or lines was shown by deviations from a straight line on the developed strip. His results

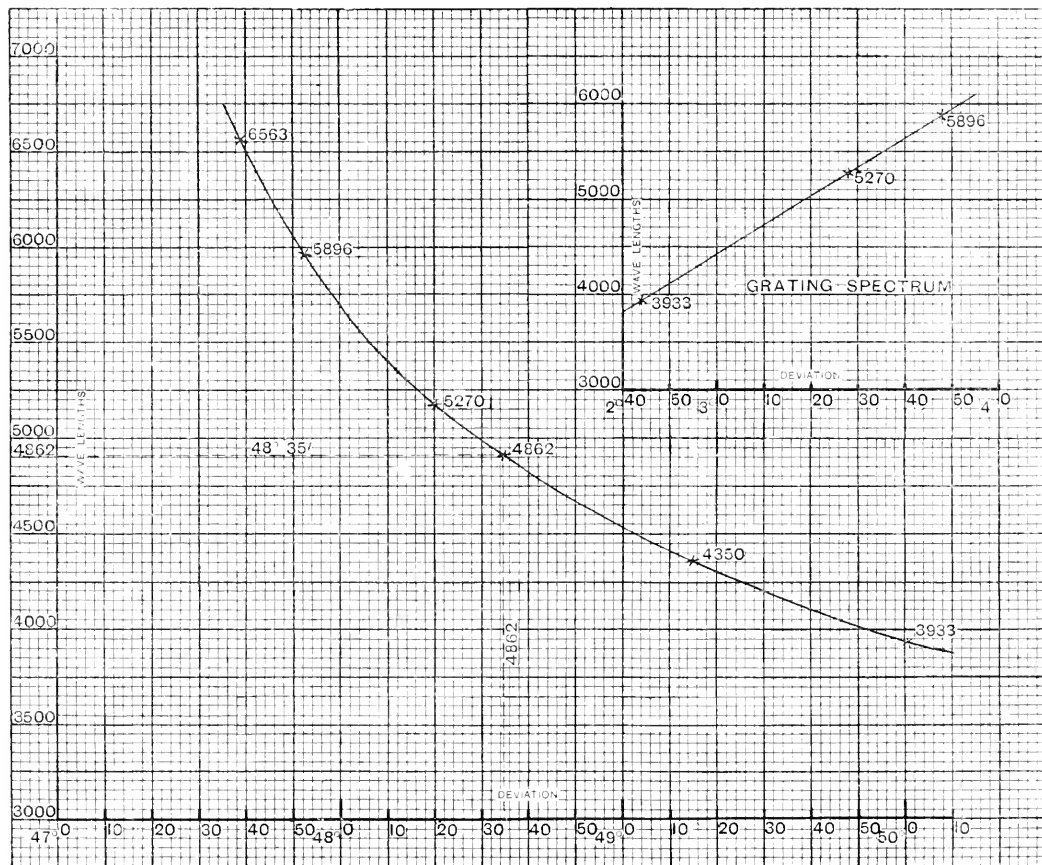

Fig. 763.—DEVIATION CURVES.

THE BOLOMETER.

Professor Langley received the waves on one arm of a miniature Wheatstone's bridge. This instrument is termed a bolometer. The increase of temperature causes an increase of resistance in the arm heated, and this increase of resistance is indicated by the deflection of a dead-beat galvanometer. The method he adopted was that of directing a pencil of

verify the negatives obtained by using the bromo-silver emulsion. For general use, ortho- or isochromatic rapid plates can be employed in taking the red end, or for taking the whole of the visible spectrum; the blue end will yield good results with ordinary plates. The word spectrum is used here in its most general sense. Any ordinary developer may be used. The continuous spectrum is only required for absorption tests.

PLOTTING CURVE FROM DEVIATION READINGS.

It will be shown later that the wave-lengths for particular rays can be independently calculated. Suppose, for example, that the deviations with the prism for several rays of known wave-length are observed. A curve can be drawn as shown by Fig. 763. The vertical heights represent wave-lengths to a certain scale, and the deviations of the lines are plotted along the base. The heights are termed ordinates, and distances along the base abscissæ. For drawing the curve given, the deviations due to the lines yielded by incandescent hydrogen and sodium and calcium vapours in the arc are given.

Line.	Deviation.	Wave-length in tenths-metres.
Hydrogen, Red	47° 39'	6563
Do. Blue	18° 34'	4862
Do. Blue-violet ..	49° 15'	4350
Sodium, Yellow D. ..	47° 53'	5896
Calcium, Yellow-green ..	48° 20'	5279
Do. Violet	50° 1'	3933

The curve obtained is the expression of the law that exists between the deviation and wave-length for this particular prism. If more preliminary points be used in defining the curve, by adding other lines of known wave-length, the curve will naturally be more accurate. With judgment, however, five standardising points should suffice. If now the deviations of the lines of an unknown spectrum be plotted on the same base, and verticals be drawn to touch the curve from these points, the lengths intercepted will give the wave-lengths corresponding to each line. The use of squared paper is very advantageous for easy plotting and subsequent calculation.

PLOTTING CURVE FROM PHOTOGRAPH.

Reproduce the distances between the lines from the negative to a convenient scale on the abscissæ. A micrometer reading microscope, provided with a vernier, should be used to ascertain these

distances, and the negative preferably illuminated by transmitted light. To facilitate calibration, the photograph of the unexamined spectrum should have the lines of hydrogen superposed. The method of doing this is mentioned later. The hydrogen gives several lines, but three are generally well defined. Draw the calibration curve from the hydrogen lines with the help of the deviation curve already obtained.

PRELIMINARY ADJUSTMENT OF SOURCE AND SLIT.

The source must be in line with the collimator axis or the lens of the latter will not be flooded with light. Open the slit widely at first, and look through the telescope with the prism removed, moving the source until the brightest possible image is obtained. Now close the slit gradually, always testing, by making slight displacements to and fro, the position of the source for maximum illumination, because in the majority of cases only one jaw of the slit is movable. The source of light should be at a safe distance from the collimator end. The slit is generally closed by a micrometer screw, so that the width of the aperture can be accurately measured. Clean the slit jaws carefully, as otherwise black horizontal lines will be seen running across the whole length of the spectrum. Each speck of dust, in obstructing a part of the entering light, stops a portion of every constituent of it. The jaws may first be cleaned with a linen rag and paraffin oil; a pointed piece of tough wood is then drawn in one direction along their edges. The wood must be cleanly cut every time it is used.

SOURCES OF LIGHT.

It should be noted that there is no danger of displacement of the spectrum lines by changing the source of light, because the image photographed is that of the slit, the source of light being used for illuminating it. To get a continuous spectrum a glowing solid must be used. There are several sources available; the simplest being an ordinary coal-gas flame. The

light, in this case, is due to incandescent carbon particles, but it is not of a good white colour. A Welsbach burner or oxy-coal-gas light would be better, but the source most used is the incandescent crater of the electric arc. In this case, the carbons are placed parallel to the slit, with the negative carbon slightly above and in advance of the positive. The crater will then face the collimator end. A scissors type of carbon holder is, perhaps, preferable, as the arc is only in use for a short time, and the adjustment can be made more delicately. The temperature of the crater is about $3,500^{\circ}$ to $4,000^{\circ}$ C. This source of light is convenient, clean, reliable, and yields a good white colour. Compare the appearance of

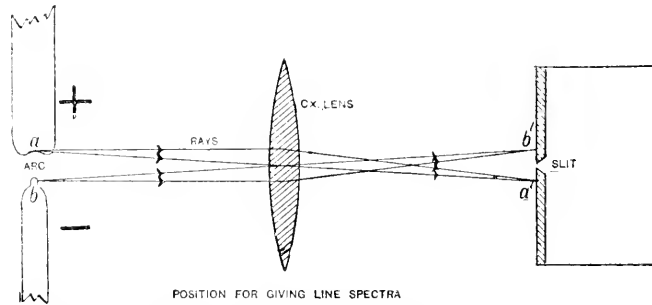

Fig. 764.—METHOD OF OBTAINING ARC SPECTRA.

an arc light with that of glow or gas lamps on the street. The former, if not of the modern "flare" type, seems to have a decided bluish-violet tinge, simply because of the preponderance of yellow in the other lights. The arc light contains a large proportion of violet and ultra-violet rays, thus being especially suitable for photographic work. In using a batwing burner, put the flame edge-wise towards the slit. A fair spectrum may be obtained without a slit by covering all but a short portion of an incandescent lamp filament and placing the latter at a focal length from the collimator lens.

INCANDESCENT VAPOURS AT LOW TEMPERATURE.

Many salts of metals when placed in the Bunsen flame tinge it with a charac-

teristic colour. This is due to some of the substance volatilising and being carried off by the flame. Thus sodium compounds give a bright yellow colour; potassium a violet; copper, a vivid green; strontium, a transient and brilliant red, etc. (The modern "flare" arc lamps

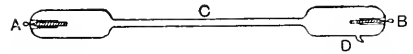

Fig. 765.—TUBE OF GAS FOR SPECTRUM ANALYSIS.

depend on the addition of certain salts to produce the characteristic glare.) Examining these flames through the spectrometer a series of luminous lines, or of lines and bands, are seen, each substance having its lines in the same relative positions as their colours in the continuous spectrum, but no two substances giving the same sets of lines. Differing spectra are obtained when different compounds of the same metal are used. The more volatile chlorides are the salts usually selected. To obtain these, mix any salt with strong hydrochloric acid, take a small amount of the mixture on a thoroughly cleaned platinum wire, and hold it in the hottest part of the flame. This can be found by previously inserting the platinum wire and noticing where it glows the brightest. Lead salts corrode the platinum badly. For reliable results, it is absolutely necessary to use a separate wire for each substance. The platinum may be pushed into the melted end of a glass rod or tube, the rod being afterwards fixed in the cork of a small bottle containing the salt solution with the platinum wire inside. It will then always be ready for use.

INCANDESCENT VAPOURS AT HIGH TEMPERATURE.

If the electric arc be used with salts of metals, spectra are obtained which agree for the same metal, therefore those

lines must be characteristic of the metals themselves. The reason for this similarity is that the temperature of the arc is so much higher than that of the Bunsen flame. Great heat tends to break up the compounds and resolve them into simpler forms, and the vapours of the metals and not of the compounds will remain in the region of the arc. With this arrangement the axes of the carbons must be placed at right angles to the axis of the collimator. The best and simplest way to manage this is not to put the hot arc near the collimator, but to insert a convex lens between the source and the slit, so that a real image of the incandescent carbons and the contained arc falls across the slit. As the vapours exist in the arc, the image must be of such a size that only the space containing the incandescent vapours is focussed on the slit, otherwise the spectrum will be a continuous one, due to the light from the glowing carbon. The preliminary adjustment of arc and collimator, previously mentioned, must be made before introducing the lens (see Fig. 764).

INCANDESCENT GASES.

The gases for this purpose are enclosed in a tube of the shape shown by Fig. 765. The part *c* is intended to be placed parallel to the length of the slit. The ends *A* and *B* have platinum terminals with aluminium extensions inside, which are connected to the high voltage terminals of a Ruhmkorff's induction coil, and the secondary current passed through the tube. The heating effect of this current makes the gas glow. The sealed projection, *D*, is where the air is exhausted by means of a mercury pump and the required gas allowed to enter. The pressure of the gas should be stated on the outside of the tube, but is seldom given. This arrangement generally requires two to four secondary cells in series with the primary of the induction coil. The strength of the current in the tube, and therefore its consequent heating effect (varying approximately with the square of the current's magnitude), may be regulated by tightening the adjusting screw

belonging to the spring of the contact breaker, or by altering the current in the primary circuit. A Wimshurst induction machine can be used instead of the coil; this will necessitate a motor to keep it in continuous rotation. It should have a Leyden jar connected to each of its prime conductors, and the terminals of the Geissler tube should be attached to the outer coatings of the jars by silk-covered wires as shown by Fig. 766. These wires, as also those of the secondary circuit of the induction coil, should be kept well apart in air, and the stand holding the gas tube should be thoroughly insulated. Avoid getting near the wires while the current is flowing, or a disagreeable shock

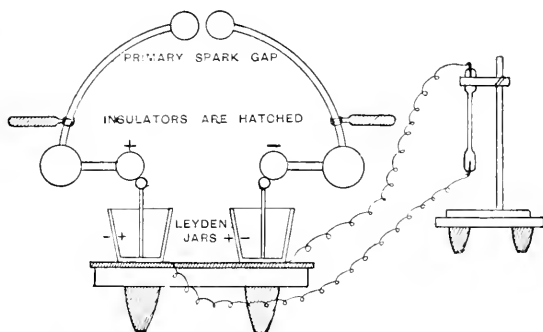

Fig. 766.—WIMSHURST MACHINE SPARKING THROUGH TUBE OF GAS.

may be received. Do not place the Geissler tubes too near the collimator when using large coils, as the spectrometer is generally made of metal throughout, and a shock might be experienced on approaching the eye to the instrument.

DIRECT SUNLIGHT.

The sun's rays are reflected on to the slit by means of a heliostat (or siderostat, as it is often termed). But, even if the light is required for a fairly long interval, it is permissible to adjust the mirror occasionally by hand, to eliminate the effect of the sun's apparent motion across the sky, since all that is required is that sunlight should enter the slit. The mirror must be concave, or a convex lens must be used with a plane mirror to focus the

rays, so that the amount of light entering the collimator is increased. If the light be too intense, the lens may be moved so as to give a larger ill-defined circular patch of light on the end of the collimator. To get any special part of the sun's disc on the slit, a concave mirror on a properly working heliostat is indispensable. Naturally, coloured glasses cannot be interposed, as they would alter the character of the incident light. Great care should be taken never to look through the spectrometer without first interposing dark glasses, when working with sunlight. Then it can be judged if the naked eye may be safely used. One way of diminishing the intensity of each part is by enlarging the spectrum. If the

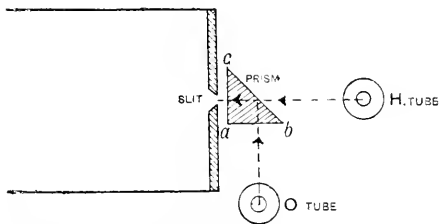

Fig. 707.—COMPARISON PRISM FOR COLLIMATOR.

mirror be pointed to a bright cloud, sunlight is still obtained, but it has suffered much reflection and absorption. The exposure for cloudlight is extremely long compared with that required for direct sunlight.

SOURCES ALTERED BY ABSORPTION.

A convenient method of studying the effect of dyes is to take solutions of various strengths in glass cells with parallel walls, and to interpose these between the slit and a source giving a continuous spectrum. The rays that are transmitted will pass through the prism and will be seen in their proper place in the spectrum, while the gaps or dark lines will indicate the rays that have either been reflected or absorbed by the solution. The examination of gases is similar to that of liquids. In the case of substances enclosed in transparent cells, the continuous spectrum must first be

examined with the empty cell in position, as the latter may have an absorptive effect. This applies to liquids also. If the absorptive power of the gas is small, the length traversed by the light through the gas must be large. Sir Norman Lockyer accomplished this by reflecting the beam of light backwards and forwards through the same tube a number of times before it fell on the slit. Glasses and prisms of quartz are used. The rays of higher refrangibility, *i.e.* those of the ultra-violet, are stopped to a large degree by ordinary flint glass.

FRAUNHOFER LINES.

The spectrum given by sunlight is not a continuous one. It is marked by fine black lines the whole of the way from the red to the violet. These lines, first noticed by Wollaston, are due to absorption. The number and distinctness of them depends on the resolving power of the observing telescope and also on the width of the slit. The immense number of these lines makes the Fraunhofer spectrum very valuable for comparison purposes with the lines of other spectra. The chief lines are denoted by the first eight letters of the alphabet. They afford a rough method of dividing the spectrum into regions, but the most satisfactory way to refer to them is by stating their wavelengths. These dark lines indicate that the radiation given out by the luminous part of the sun, the photosphere, is partially absorbed by a cooler layer of the same illuminating substances surrounding it, called the reversing layer. This effect can be shown very simply as follows. Use an arc light giving a continuous spectrum, and interpose a sodium flame between the arc and the slit. The incandescent sodium vapour alone gives two bright yellow lines very close together (D_1 and D_2), but under the circumstances just mentioned a bright spectrum will be seen crossed by two vertical dark lines where the two yellow lines were seen before. The Bunsen flame is cooler than the arc crater, and, as a result, it absorbs energy in the form of the radiation it emits itself, from the more intense light

given out by the arc. Matter always absorbs those radiations most easily which it gives out itself when excited and allowed to vibrate freely. The absorbed vibrations will be of greater amplitude than those of the absorbing particle, *i.e.* the source giving out the vibrations will be hotter than the body absorbing them, for increased activity of molecular motion means increase of temperature.

SCIENTIFIC USE OF ABSORPTION LINES.

In these absorption lines lies the key that first opened up the great possibilities of the spectrometer. The substances that are present in the sun can actually be found out almost as easily as those occurring on earth, although these elements are 92 millions of miles distant. Each substance when vaporised yields lines peculiar to itself. In the same manner that the reversed sodium line indicates the presence of sodium between the source of light and the slit, the Fraunhofer lines prove the existence of certain substances in the inner and outer layers of the sun. Some of the lines, however, are due to absorption whilst the rays are passing through the earth's atmosphere. When the sun's rays have to pass through thicker layers of air at sunrise and sunset, these lines will become more prominent, and they may be identified and eliminated from the solar absorption lines. The violet and ultra-violet rays suffer most absorption on account of their small wave-length.

TABLE OF WAVE-LENGTHS OF ABSORPTION LINES.

Line.	Substance.	Wave-length in tenths-metres.
A	Dark Red ..	Aqueous Vapour 7621
B	Deep Red ..	Aqueous Vapour 6884
C	Red ..	Hydrogen 6563
D ₁	Orange- ..	Sodium 5896
D ₂	yellow ..	5890
E	Yellowish-green	Calcium 5270
F	Greenish-blue ..	Hydrogen 4861
H	Violet ..	Calcium and hydrogen 3968
K	Do. ..	Calcium 3933

NOTE.—A tenth-metre means ten-millionth of a millimetre.

ARC SPECTRA WITH FRAUNHOFER LINES.

With collimators specially adapted for this class of work the slit is a very long one covered by two to five sliding doors, which provides for two to five spectra being obtained on one plate. The heliostat is moved by hand. It must be noted that the narrower the slit is, the longer will be the exposure. That is, however, no detriment, and the definition is remarkably improved by a small decrease in the slit width when nearly closed. It saves much trouble if a fiducial mark in the shape of a pointed wire be placed where the source of light is to be, when exchanging the arc for other illuminants or when changing carbons. Take care to keep the distance between the carbons constant. When these are impregnated with salts the arc is very unsteady and has a tendency to wander round the edge of the carbons, the crater, of course, travelling round with the arc. One fairly good way of preparing the carbons is to take the cored one and allow it to stand in a small amount of the salt solution. Since the core is of looser texture than the rest of the stick, the middle part gets impregnated most strongly with the salt. This tends to keep the arc central. The carbons should be allowed to dry thoroughly before use. The small positive carbon can also be soaked. Look at the arc only through a pair of glass plates, one ruby, the other blue; otherwise the glare of the arc renders the eye useless for fine focussing for some considerable time.

COMPARISON OF SPECTRA.

When once a spectrum has been calibrated, it can be used for calibrating others obtained from the same prism if some method be adopted for placing the same side by side without any relative displacement. This is very conveniently done by covering one-half of the slit with a total reflection prism. To get, for example, the spectra of hydrogen and oxygen in view at the same time for comparison, the tubes are placed at equivalent distances from the slit, as shown by Fig. 767.

The rays from the hydrogen pass directly into the uncovered top half of the slit, and are brought to a focus in the bottom half of the telescope tube. The side *b c* of the prism reflects the lower half of the hydrogen rays so that they do not enter. The oxygen rays pass at right angles to the surface through the side *a b* of the prism, and are reflected internally at the surface *c b*, passing into the lower half of the slit to be brought to a focus like the hydrogen rays, but in the upper half of the tube. Evidently the two may be photographed at the same time. The exposure for oxygen may need to be prolonged beyond that of hydrogen, owing to loss of light in travelling through the prism. The extra exposure is easily arranged by interposing a black card to

of two pieces of wire of the substance that is being examined. These are, like the Geissler tubes, put in series with the secondary of the Ruhmkorff coil, as shown by Fig. 769. As the current leaps across from one terminal *a* to the other *b* it vaporises the metal, and the spark is coloured by the glowing metallic vapour. There is some disagreement as to the temperature attained at spark gaps and in Geissler tubes. Some observers put the temperature in the tubes at a much higher value than that of the electric arc. The spark gap must be adjustable, and, if "long" and "short" lines are required, it must be placed at right angles to the slit length, as in the case of the arc. The terminals, *a* and *b*, are often enclosed in a glass tube, which can be

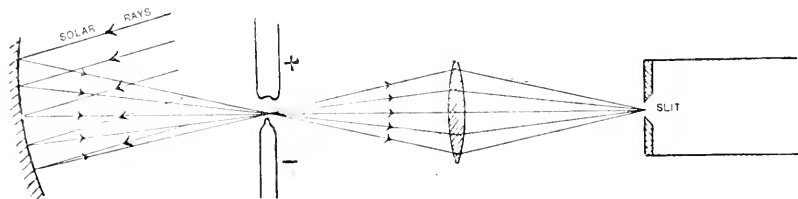

Fig. 768.—PROJECTION OF SOLAR RAYS ON COLLIMATOR SLIT.

intercept the hydrogen rays at the proper time. The spectra for both will be simultaneously in focus, because images of the same slit are being photographed.

ARC AND SUN.

Another method is available with arc spectra. A heliostat is arranged so as to reflect sunlight between the carbons. On covering different halves of the slit, *i.e.* having one slit with two sliding doors, and exposing separately for each source, two spectra, one due to the arc and the other due to the sun, will be obtained side by side. By the arrangement shown in Fig. 738 both sources of light diverge from between the carbons, and the same adjustment of the camera is, of necessity, accurate for both images.

SPARK SPECTRA OF METALS.

A very simple method of observing the spectra of metals is to make a spark gap

filled with other gases than air, to examine the effect of these on the spark. The pressure of the enclosed gases can also be varied. *A* indicates the adjusting screw.

INTERRUPTING THE CURRENT.

One of the most important things to notice is the effect of temperature. The amount of energy given out at the spark gap depends on the product of the voltage and current there. This can be altered by varying the periodicity of the vibrating armature as described previously, by altering the length of the spark gap, or by having an auxiliary adjustable spark gap in series in the secondary circuit. In the more expensive forms of induction coils the interrupter is either electrolytic in character, like the Wehnelt break, in which the interruptions are caused by bubbles of liberated hydrogen, or of the mercury type, in which a revolving plate, with symmetrically placed apertures, is attached to a motor. The

plate breaks a conducting jet of mercury which forms part of the primary circuit a large number of times per second. The rate of interruption of the current can be adjusted at the motor. The stream of mercury is kept constantly flowing by means of a centrifugal pump also worked by the motor. The Wimshurst influence machine may also be used for this work, if desired, and if the Leyden jars attached to the primary circuit are of a large size, the quantity of electricity discharged at each spark is correspondingly large. An alternating current of very high periodicity may be passed through the primary coil, in which case no interrupter is required.

DIFFRACTION SPECTRA.

No solid advance was made in accurate measurement of the wave-lengths of light as long as prisms alone had to be used for producing spectra. The fact that the light must penetrate the glass makes the results dependent on the material. Notice the simplicity of the laws of reflection compared with those of refraction. For instance, the principal focal length of a mirror can be determined beforehand by simply having a knowledge of its geometrical dimensions. There is no such absolute certainty about preparing a lens of given focal length, or determining the deviation given by a prism whose dimensions are known. The first step towards the present methods employed in the measurement of wave-lengths was made when Newton noticed that light in passing by the edge of opaque bodies gave irises of colour, as he termed them, inside the edge of the shadows. These results can only be explained on the theory that light has something of the nature of a wave motion. As a matter of fact, light, heat-radiation, and the electro-magnetic waves of wireless telegraphy obey the same laws throughout, the only difference being in their wave-lengths. To get a concrete idea of what happens when light passes the edge of an opaque body, imagine a series of water waves impinging at right angles against a breakwater. Behind the breakwater, of course, no waves would be seen, but at the end of the wall the

disturbed water would not be separated from the still portion by a straight line drawn in the direction of motion of the advancing waves. Secondary wavelets would bend inwards from the end of the wall, still travelling in straight lines, and the smaller the length of the waves the more bending there would be. This secondary effect is called diffraction, and must not be confused with the refraction of the whole of a ray when passing through a prism.

EFFECT OF A RECTANGULAR SLIT.

If the wave be incident on a vertical, rectangular aperture, the disturbance that arises there will spread out on both sides

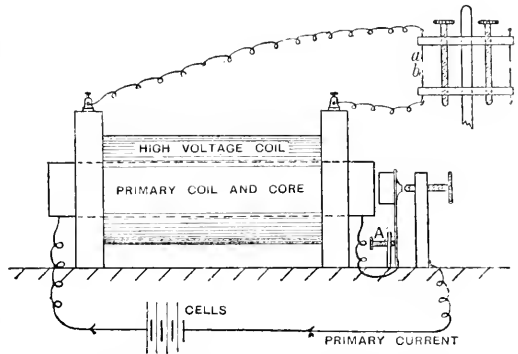

Fig. 769.—INDUCTION COIL AND SPARK GAP.

because there are two edges. In the case of a beam of light incident on a slit, the spreading out is comparatively very great because the wave-lengths are so very small. The wave-length of sodium light is 0.0005890 cm., or a little more than $\frac{1}{170000}$ in. As mentioned before, in connection with the collimator, the simplest way of understanding what happens at the slit is to consider it as a secondary source of light. Since, however, it has a sensible width, each point along it will do its share in sending out disturbances, so that the resultant disturbance will be of a more complicated nature than the original one. Experiments have been conducted and photographs have been taken of wave disturbances of mercury which fully support this idea.

INTERFERENCE.

If two stones be allowed to drop simultaneously into a pool, at a distance of a few feet apart, each on striking the water will send out a series of waves in rings. Soon one set of rings will begin to interfere with the other set. Where a crest meets a crest there will be an extra heap-

of time or of distance, and the height from the time line represent the velocities of particles. Then the diagram will represent two things: first, the velocity of one particle at every moment; and secondly, the velocity of all the particles at one particular moment. In the latter case the divisions from 0 represent distances from the centre of disturbance. The effect of friction has been neglected.

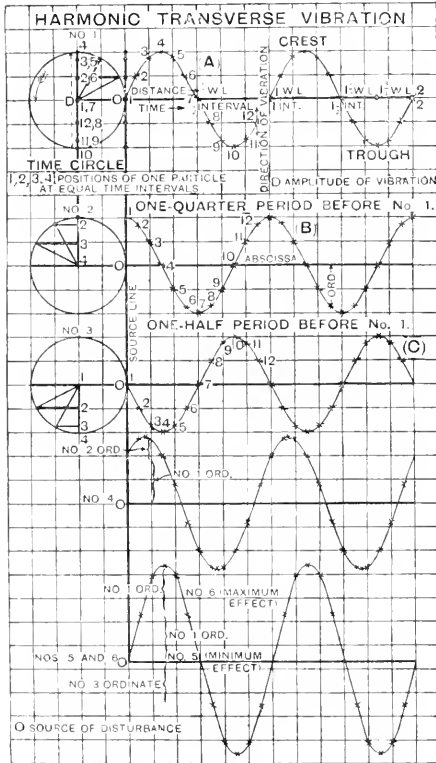

Fig. 770.—EFFECTS OF WAVE DISTURBANCE.

ing up of the water; where a trough meets a trough there will be a double hollow; where a crest meets a correspondingly equal trough the water will be undisturbed. A vibration is completed when a crest and a trough have been formed. When one particle is at exactly the same stage of vibration as another particle of a different wave, the two are said to be in the same phase. This is illustrated graphically by Fig. 770. Let horizontal distances from 0 be intervals

EFFECTS OF WAVE DISTURBANCE.

Three wave disturbances of different phases are shown by Fig. 770. Particles A, B, and C are in the same phase, considering them either at different intervals of time or at different distances from the centre of disturbance. The second wave disturbance is a quarter period or quarter wave-length later than the first. The third wave disturbance is half a wave-length. The effect of adding No. 1 to No. 2 is shown in curve No. 4. When distances above the base line are added to distances which come below it, the arithmetical difference must be taken and the excess plotted above or below according to the result obtained. No. 5 shows No. 1 and No. 2 added together, and is a straight line, indicating that there is no resulting disturbance. No. 6 shows two curves like No. 1 added together, which may represent, of course, the addition of two waves with a difference of phase of any number of complete wave-lengths. This is a maximum result, whilst No. 5 is a minimum. Between these two there are naturally intermediate results of disturbance. The points to remember when applying the wave theory to the explanation of the action of rays of light giving diffraction effects are (i.) two equal sets of waves, which are an odd number of half-periods apart, give no resultant illumination; (ii.) two equal sets of waves, an even number of half-periods apart, give a maximum illumination; (iii.) the two wave-lengths must be equal to produce this result.

THE DIFFRACTION GRATING.

The case of parallel rays of light falling on a series of equally-spaced long and

narrow rectangular apertures may be now considered. This arrangement of apertures is termed a grating. By the wave theory it can be proved that the light which enters slit s (Fig. 771) takes the same time to get to the grating along any of the paths through the lens L_1 . Since the light is entirely from one small

odd number of half wave-lengths behind that coming from b , there will be no resultant light at z from these two apertures, and therefore no image. As the same thing happens with each pair of apertures, no image at all will be formed in this direction. If the difference of path be an even number of half wave-lengths

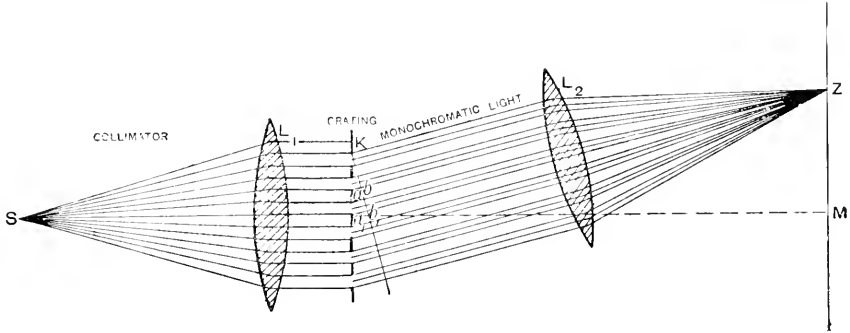

Fig. 771.—FORMATION OF DIFFRACTION SPECTRUM.

source, it will all be in the same phase of vibration at the time it reaches the grating. This idea is usually expressed by saying that the wave front is parallel to the surface of the grating. Since the light is of small wave-length, as it passes through the slits it diffracts practically in all directions from each slit. In the diagram, therefore, for the sake of simplicity, but one colour has been considered, and only one direction for that colour. On interposing the lens L_2 at right angles to these parallel rays, a real image of the slit will be obtained at z under certain conditions. The lens is now parallel to the line κb_1 . Consider the light passing through a to a_1 . The light at point b is ultimately added to that at b_1 to make the image at the principal focus of L_2 . But these two beams are not obliged to arrive at the image in the same phase. Between these two corresponding rays there is a difference of path equal to the difference of $a b$ and $a_1 b_1$. This at once enables the difference of phase to be estimated. If the beam going from b_1 is an

there will be a maximum of light, and consequently there will be a bright image at the focus of L_2 . Directly opposite to the original direction of the incident light

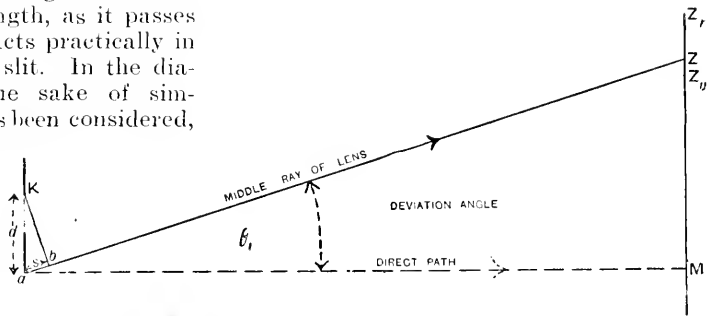

Fig. 772.—RELATION BETWEEN DEVIATION AND RULING SPACES.

at m a bright image would be made by L_2 when L_2 is placed in the proper position for focussing it, since all the light arriving at the focus would be in the same phase, having traversed equivalent paths. It would seem, at first sight, that on moving towards z the light should gradually fade from m , the place opposite the middle of the grating, to a line of darkness, and then rise to a maximum of light to fade away again, repeating these effects as far

as observations were taken in the direction mz . But, owing to the interactions of the light from all the apertures, periods of darkness broken by distinct lines of light are seen when the light falling on slit s is monochromatic.

EXPRESSION FOR DEVIATION.

The deviation may be expressed in terms of the wave-length and the dis-

it can be made approximately near the size required and then measured accurately afterwards.

RULING TRANSMISSION GRATINGS.

The grating just considered is termed a transmission grating. The arrangement of alternate transparent and opaque strips is obtained most easily by ruling fine lines with a good diamond on prepared glass surfaces. The transmitting portion is the unscratched part, the lines made by the diamond diffusing the light and acting as the opaque strips. This ruling is a very troublesome and delicate operation. First

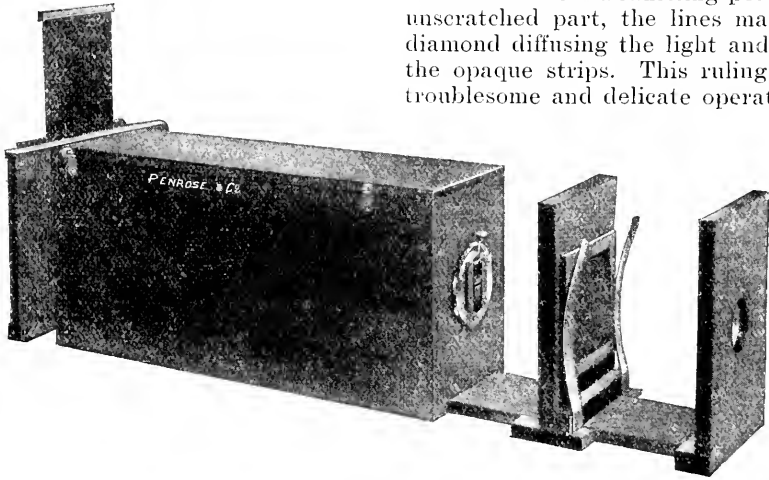
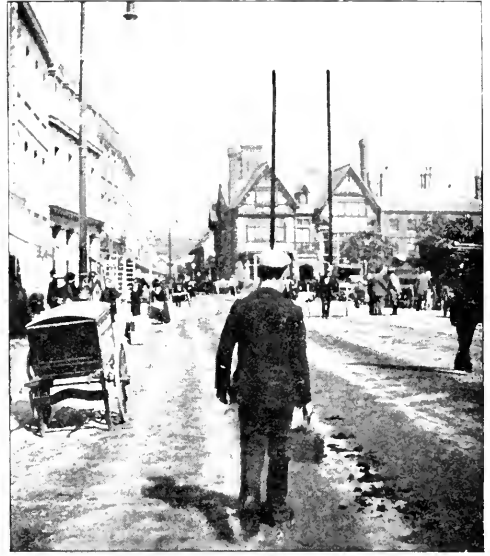

Fig. 773.—TALLET'S DIFFRACTION GRATING SPECTROSCOPIC CAMERA.

tance from one aperture to the next. This is equal to the sum of the width of the aperture and of the material separating the apertures. If this distance be called d (see Fig. 772), δ represents the retardation or difference of phase between two similarly placed rays. Triangle kab is similar to a $z m$. $\therefore \frac{\delta}{d} = \frac{zm}{az} = \sin \theta$ where θ is the angular deviation of any ray. Now δ for a maximum of light is equal to $2n \times \frac{\lambda}{2}$, i.e. an even number of half wave-lengths where n is any number and λ denotes wave-length. The equation may therefore be written $\lambda = \frac{d}{n} \sin \theta$ for a bright line. Here, then, is a simple relation between the wave-length and the deviation. The distance d can be made any size, or rather, since it is so small,

the diamond point has to be carefully selected. Its scratch is carefully examined under the microscope. It may not give a steady cut, and perhaps only cuts one way. If faulty in any particular it has to be rejected. The best points, too, are often spoiled after ruling only a few lines on glass, owing to its comparative hardness. The spacing of the lines is automatically adjusted somewhat after the manner of the feeding of the cutter in a planing machine. The glass which is being ruled must also be kept at a steady temperature, as any expansion or contraction necessarily alters the spacing of the lines, though this effect is of much less importance than in the case of metallic gratings, described later on. Rutherford was one of the first investigators who produced reliable gratings. The distance d is obtained by counting carefully under



STEREOSCOPIC PICTURES SHOWING DIFFERENCE OF SEPARATION BETWEEN LINES DRAWN THROUGH CORRESPONDING POINTS.

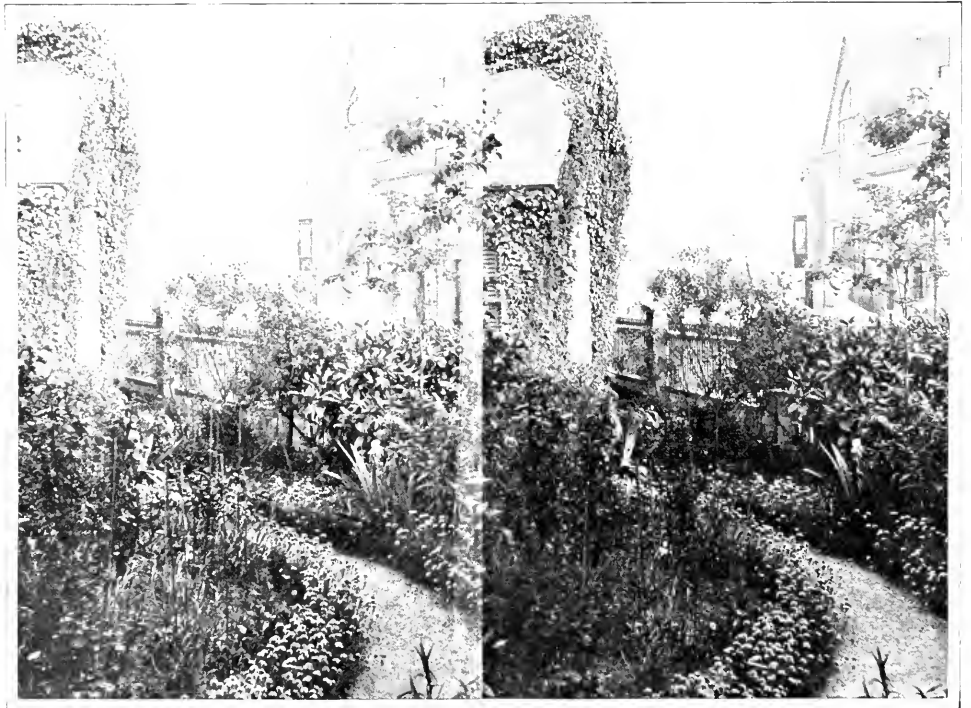

STEREOSCOPIC PICTURES TAKEN ON ONE PLATE BY TURNING THE CAMERA ON ITS AXIS BETWEEN THE TWO EXPOSURES.

a microscope the number of lines in a given distance and dividing the latter by the former. It will be seen from the formula given that the smaller the distance d is made, the greater the angle θ . Therefore everything possible is done to obtain the largest number of distinct, even lines in the smallest space. The ordinary grating used with a spectrometer in laboratory work has no less than two or three thousand lines per inch. It has, however, been found comparatively easy to rule up to 14,000 lines per inch.

FORMATION OF THE SPECTRUM.

Each colour has been shown to give definite lines at definite distances along the line $\mathcal{M}\mathcal{Z}$. Consider only the first lines of colour on one side of \mathcal{M} . If white light be incident on the slit, since the violet rays have the least wave-length of those visible to the eye, the difference of path in the case of these rays for a complete wave-length is less than for any of the other rays of the visible spectrum, and it can easily be seen that the images for the violet rays (z_v) must be nearer \mathcal{M} than those (z_r) for the red rays. Thus we get a spectrum, but in the inverse order of colours to that produced by a prism, since the violet rays have the least deviation. The colours have naturally the same relative order as before, but the red part of the spectrum occupies a greater proportionate length than in the prismatic one. The grating spectrum is termed "normal." Another difference is that theoretically an infinite number of spectra are produced on either side of \mathcal{M} , but, after the second, they overlap, since the wave-length of the red is approximately twice that of the blue. It will be seen that, as before, only one colour can be in exact focus on the line $\mathcal{M}\mathcal{Z}$ at one and the same time. All the spectra are not equally good. Each grating has its peculiarity. One spectrum may be much brighter than the rest owing to local properties of the ruling, another may have the violet end particularly good, and so on. These little differences are, however, seldom of sufficient consequence to seriously affect the scientific accuracy of the results obtained.

ADVANTAGES OF DIFFRACTION GRATINGS.

Since the deviation, and therefore the position and width of the colours, depends only on the number of lines per inch on the grating, all spectra produced by exactly similar gratings are absolutely identical copies of each other. Each colour has an invariable width. With different gratings the spectra only vary in being formed on different but proportionate scales. Some prisms, and especially liquid prisms, vary much in the amount of local dispersion of the colours, but with gratings no such irrationality of dispersion occurs (see Fig. 763). There a curve showing the relation between deviation and wave-length for three of the calcium lines has been drawn for com-

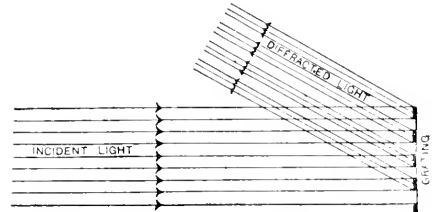

Fig. 774.—DIFFRACTION BY REFLECTION AT A PLANE GRATING.

parison with the prismatic one. The resulting curve is a straight line, showing that the wave-length is in direct proportion to the deviation. For such small angles as 3° the angle and its sine are practically identical. A transmission grating was used which had about 3,000 lines to the inch. It will also be noticed that the diagram shows that the deviation is less for the more refrangible rays. Fig. 773 shows Tallent's Diffraction Grating Spectroscopic Camera, an excellent apparatus for its purpose. Plate 16 illustrates various spectrum results obtained by its employment.

REFLECTION GRATINGS.

The next kind of grating to be considered is the reflection type. Let a transmission grating have the ruled surface cleaned very carefully and then be silvered. Consider the effect on an in-

cident beam of light (Fig. 774). Just as the apertures in the grating were considered as sources of diffraction, so smooth portions of the silvered grating may be considered as similar sources on account of the regular reflection which takes place. The deviation is now $(180^\circ$

handled much in the polishing, the parts heated by the fingers would rise and too much would be taken off. Although the fault is imperceptible to the eye, it is sufficient to spoil the definition.

CONCAVE GRATINGS.

Mention has been made of the use of quartz prisms and lenses for spectrometry.

The prism and convex object glass of the telescope, however, may be entirely dispensed with, by using instead of a plane grating a concave one, which, in diffracting, will cause the rays to come to a focus.

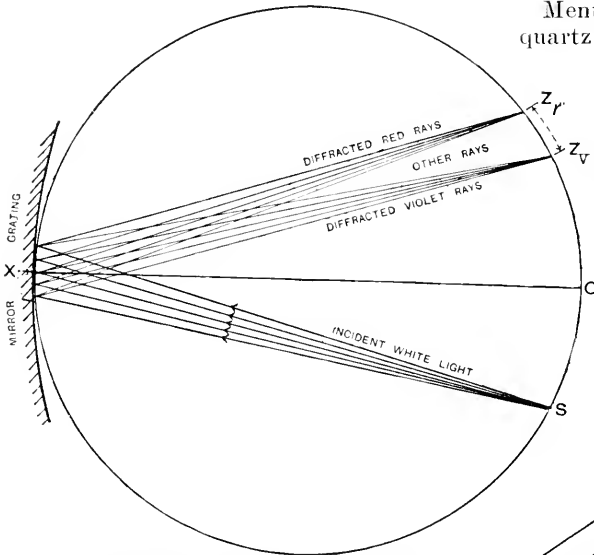

Fig. 775.—DIFFRACTION AT A CURVED GRATING.

$-\theta$), but since $\sin(180^\circ - \theta)$ has the same value as $\sin \theta$, the formula is precisely the same. If the deposit of silver be thick, the silvered surface may

be polished and exposed to the incident beams, but the silver tarnishes in time, and nearly correct readings may be got on exposing the glass face to the rays, although then the rays have to travel through two thicknesses of glass. Simple reflection is, however, always best. This is obtained by ruling a polished speculum-metal mirror. The ruling is easier than on glass, but as the expansion error is greater, the ruling must be slower to avoid local heating, and much more care is needed in handling. If the mirror were

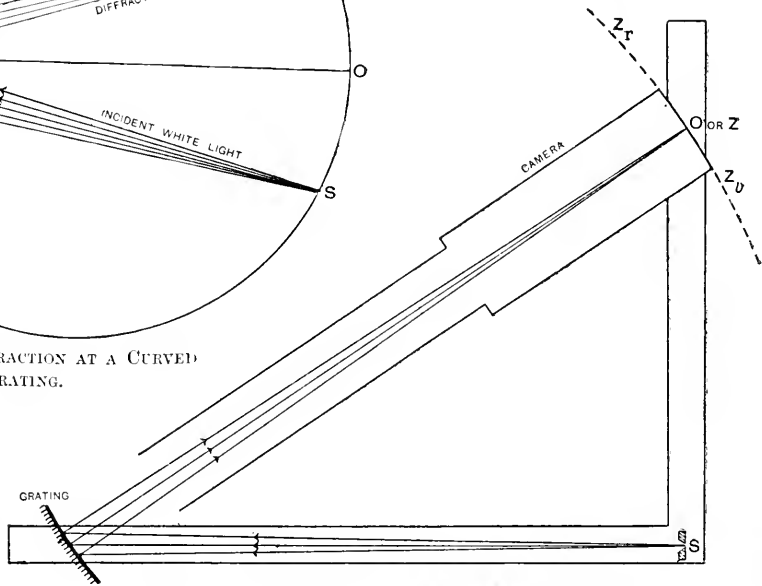

Fig. 776.—ROWLAND'S PHOTOGRAPHIC ARRANGEMENT.

Although the mirror is concave, the ruling consists of a series of parallel lines marked across it in precisely the same manner as if it were plane. The images are due to a slit source and are themselves lines. The arrangements for observing the spectrum are the same as before. Concave metal gratings have generally been prepared from speculum metal but lately a method of electrolytically depositing silver on a properly curved surface of glass, and over that a backing of copper, so that when the silver is removed it will already

possess a brilliant polish, has been brought to the front.

ROWLAND'S METHOD.

The marked superiority of these gratings lies in the following features, which have been taken advantage of by Rowland in a masterly manner. Let a circle be described with the radius of curvature of the concave mirror as its diameter. The image of a source s (Fig. 775) of violet light on the circumference of this circle, produced by diffraction (not by the ordinary rule for finding the image due to a concave mirror), will be formed at a point z_v on the circumference of the same circle. A corresponding result is obtained for each wave-length, consequently, the first diffracted spectrum lies along the circumference from z_v to z_r . Rowland places the eyepiece or camera at o , *i.e.* z and o must coincide at the centre of curvature of the concave mirror. This arrangement makes z —the part of the spectrum at point o —point s and point x lie at the corners of a right-angled triangle, with z s always at right-angles to s x . o x must be of constant length. This property enables the camera and grating to be fixed at the end of a rigid support. There are now two ways of bringing the various spectra or parts of the spectra to o : (i) by moving the slit along the circumference of the circle indicated, when the spectra will sweep past o in the usual order; (ii) by keeping the slit fixed and moving the arm o x so that its extremities o and x travel along two directions at right angles, the slit being at the corner of the right angle. The first method is manifestly too inconvenient to adopt. The second is obtained in the manner shown by Fig. 776. Placed along the directions s o and s x are two rails on which run the wheels under the platforms supporting the camera and grating. The diagram shows the camera in position for photographing part of the blue spectrum. To get all the lines in focus for any section, the plates must be bent to fit on the circumference of the circle mentioned before. As the length of o x in Rowland's apparatus is 43 ft., and the plates used for the solar spectrum are 19 in. long and only

$\frac{1}{14}$ in. thick, this is easily done. The sun's rays are thrown by a condensing lens on to a totally reflecting prism and then enter the slit. The gratings used have from 10,000 to 20,000 lines per inch. The adjustment of the slit has to be very accurate, and its width is not more than $\frac{1}{1000}$ in. The spectrum is so long that it has to be photographed in several sections.

ADVANTAGES OF REFLECTION GRATINGS.

With a reflection grating there is the least possible absorption, as the rays do not of course enter the substance of the mirror. Were it not for the excessive absorption of the rays of short wave-length by the air, the exact extent of the ultra-violet of the solar spectrum might be ascertained. The relation between wave-length and deviation is simple. Each inch on the negative means so much difference of wave-length. Metallic reflection gratings are larger than glass ones, consequently the distance d between two adjacent lines may be more accurately measured, and more light, also, is brought to a focus, rendering the spectrum brighter. Prismatic spectra are, however, undoubtedly brighter in themselves, as only one spectrum is produced, whereas, with a grating, the light is distributed amongst several spectra.

REPRODUCTION OF TRANSMISSION GRATINGS.

For laboratory work, cheap substitutes for the more expensive ruled gratings are easily obtained by placing a sensitised plate in contact with one of the glass transmission type. The light cannot pass through the ruled parts, so that, on developing and fixing, a negative of the grating is obtained. This causes the incident light to diffract precisely as the original grating did. If mercury be placed at the back in contact with the film it will act as a reflection grating. For good definition, when used in this latter manner, the glass carrying the film must be of even thickness and have good plane surfaces. Talbot's Bands may be seen with a grating made in this way. Collodion plates are best. When examined under the micro-

scope, the deposited silver is seen to be in much smaller particles, and to be fairly evenly distributed. With ordinary gelatine plates, the silver occurs in larger, irregularly sized aggregations. The glass surface should be presented to the incident light coming from the collimator lens. This will avoid small refraction errors, and, when not in use, there should be a glass cover to protect the film, only exposing the latter during the actual time of observation.

to be coloured, and which lies nearest to the collimator, is the one to be taken. The plane of the grating must now be making an angle of 45° with the incident rays of light. Round the circumference of the table which carries the prisms is marked a scale, and this enables the grating to be turned round through 45° in order to be at right angles to the incident light as shown. If it is a transmission grating, the telescope is moved back to position A, where a very bright yellow slit

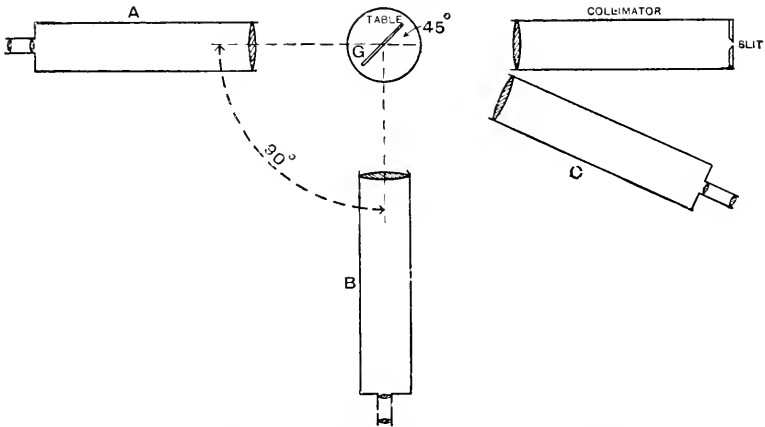

Fig. 777.—ADJUSTMENT OF SPECTROMETER FOR DIFFRACTION SPECTRA.

ADJUSTMENT OF SPECTROMETER AND GRATING.

Adjust the telescope and collimator for parallel rays as before. Having removed the grating G from the turning table (Fig. 777), illuminate a very narrow slit with the sodium light, and bring the image on the cross wires of the telescope. Clamp and take the reading of the telescope vernier. Unclamp, and move the telescope accurately through 90° . The collimator will now be exactly at right angles to the telescope tube. Clamp the telescope, place the grating vertically on the turning table, and turn it until its surface reflects the light from the slit into the telescope. Adjust the image again on the cross wires as before, by carefully moving the grating. There will be two images seen with a glass grating, one reflected from the front surface and the other reflected from the back surface. The first one, which is less likely

will be seen, and on moving the telescope in either direction, other similar images, which become fainter as the deviation increases, come into the field. Five on either side are easily seen. Replacing sodium light by the crater of the arc light, continuous spectra are obtained instead of lines. The image seen when the telescope is in line with the collimator axis will be a bright slit of white light, since each of the colours arrives at that point with all its rays in the same phase. If the grating be of the reflecting type, the telescope is moved round to position c, where the first spectrum will probably be seen. The direct diffracted image of white light is reflected back to the collimator slit and is not visible.

MAKING SPECTROMETER.

With the spectrometer now to be described, extremely satisfactory spectra may

be easily observed or photographed. The most expensive item, *i.e.* the prism, can, however, have no good and cheap substitute, and to get the separation of the D lines two ordinary prisms must be used. The table is made large so that the tele-

card is glued on to the base. The best way to make such a scale is to divide the circle into arcs of 30° , and divide each 30° into 10° by trial. The 10° should now be accurately bisected, and the resulting 5° arcs again divided into degrees by trial.

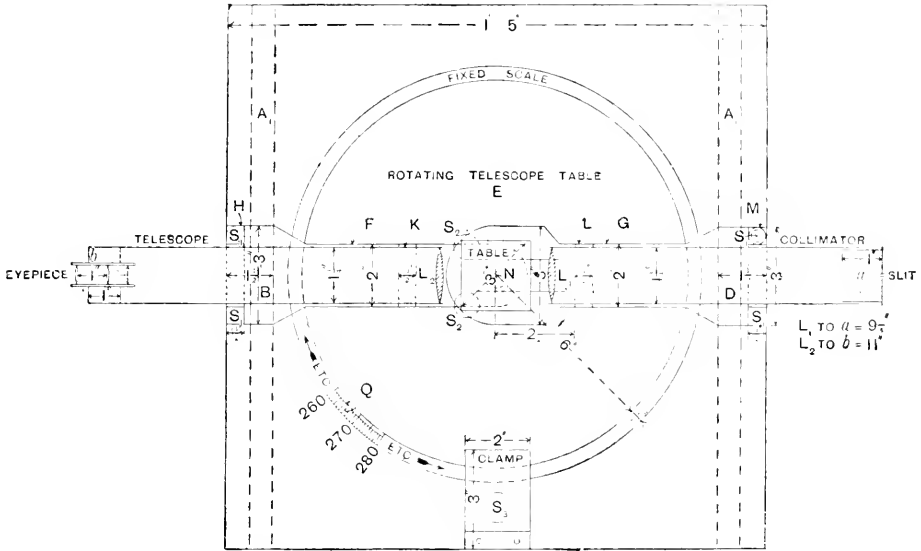

Fig. 778.—PLAN OF HOME-MADE SPECTROMETER

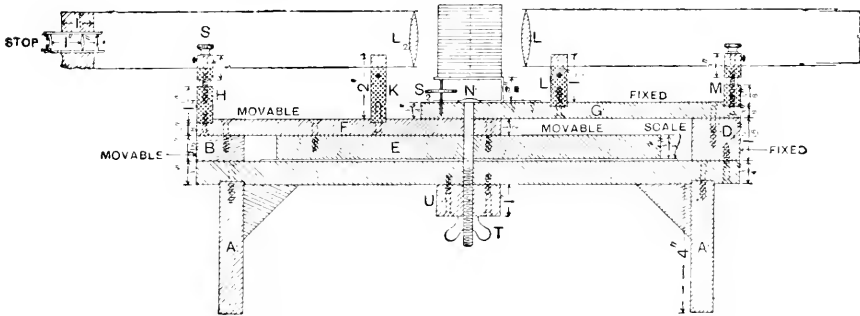

Fig. 779.—ELEVATION OF SPECTROMETER

scope and collimator are subject to no vibration or movement. The crossbars A_2 , A_1 (Fig. 778) must be mortised slightly into the 17 in. square base, and they must go across the grain to prevent warping. The wood used should be either mahogany or walnut for all the parts. The scale is made of cardboard and can be bought. If the divisions, however, be marked out by compasses, this should be done after the

THE TELESCOPE CARRIER AND TABLE.

The arm carrying the telescope is firmly screwed to a large circle of wood E, which must be accurately turned or spoke-shaved; and, so that the clamp which bears on the right side may always have a good grip, the surfaces of the rotating table should be most carefully planed. This circular table has been added to save

the continual adjustment that is necessary with most amateurs' spectrometers, and if pains be taken to get it of even thickness, it will prevent a good deal of trouble. The block B takes advantage of the size of the table, and gives support to the telescope as near as possible to the eyepiece. The collimator arm is fixed permanently to the large square base. It might have been placed lower than the telescope arm, but then the fixing of the prism table would have been a troublesome matter. Besides this, it will be seen that the centre of rotation of the telescope is adjacent to the scale, and therefore there will be less danger of eccentricity. The bolt x is also always held vertically. Fig. 779 shows the elevation, the lettering being the same throughout.

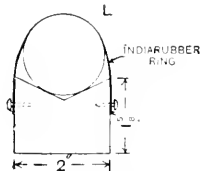

Fig. 780.

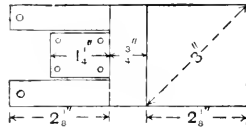

Fig. 781.

Fig. 780.—DETAILS OF SPECTROMETER STANDARDS
Fig. 781.—DETAILS OF PRISM TABLE.

STANDARDS.

The four standards H, K, L, M must be made with the grain running horizontally. They are of two types. K and L are simple in construction, but the V-grooves must be adjusted to the same level from the table with the greatest nicety. H and M are made adjustable. The screws are easily obtained at any electrical shop. The spring may be part of an ordinary clock spring, and should be under half the possible compression in the position shown. On each of the four standards are two brass pins for catching the stout elastic rings which hold the tubes in place. H and K are, of course, higher than L and M. Figs. 780 and 783 show the details of the upper portion of the standards.

PRISM TABLE AND COLLIMATOR.

The prism table (see Fig. 781) may be cut out of one piece of not too thin sheet brass.

The middle tongue is turned so that it can be screwed on to the part of the collimator arm near L. The two side tongues turn under the table. Each is previously tapped to receive the screw s₂, which by pressing against the under side of the table, makes it easy to get the prism accurately vertical. s₂ must be of very small pitch. Fig. 782 is a conventional view of the prism table. The collimator will now be described. The lens should be preferably corrected and consist of flint and crown glass cemented together. The focal length is 10 in. The tube may be of cardboard, but brass would be more satisfactory. The lens may be fixed by first introducing a thin strip of cardboard, which is attached with glue or "Seccotine" to the inside to make a ring. Against this the lens can rest, whilst another outside ring will prevent it from falling out. The cardboard and the inside of the tubes should be first blacked with a mixture of lamp-black, size, and methylated spirits.

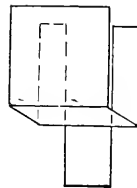

Fig. 782.

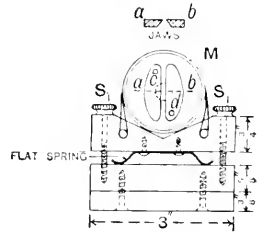

Fig. 783.

Fig. 782.—ISOMETRIC VIEW OF PRISM TABLE.
Fig. 783.—DETAILS OF SLIT AND ADJUSTABLE STANDARD.

THE SLIT.

The slit is fixed on to a short tube which will just slide inside the larger one. The slit jaws are riveted by brass pins c and d (Fig. 783), to the end plate of brass, which is then soldered to the end of the short tube. In the middle of the end plate is bored a small circular hole, which defines the length of the slit. It will be seen that the jaws a and b may always be placed parallel, by employing the device of placing the rivets on opposite sides of the end aperture. The jaws must be ground accurately parallel, with their edges bevelled as shown. The bevel must be

inside, so that the light will be able to diverge. The jaws may be of steel, and it would be better, perhaps, to replace *c* and *d* by little screws, as then the jaws could be removed for regrinding or cleaning.

THE TELESCOPE.

The object glass *L*₁ must be like the collimator lens. The piece *B* in which the eyepiece slides may be of wood or cork, but should be firmly cemented in place. The eyepiece tube should be brass, and the two lenses should each be of $1\frac{1}{2}$ in. focal length. A paper tube 1 in. long should be inserted (after blacking) into the brass tube to keep the lenses the proper distance apart. The latter may then be

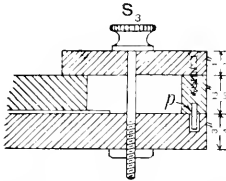

Fig. 784.—SECTION OF CLAMP.

fastened as before described. The necessary stops for the eyepiece may be of blackened cardboard, introduced into the front as shown. In visual observation there is no advantage in having the exit for the rays greater than the pupil of the eye. The telescope must be blackened inside

CROSS WIRES AND CLAMP.

Take a cork that will just enter the back of the eyepiece, and cut off a length of about a quarter of an inch. Bore out the centre, and black the ring obtained. Across this ring fix tightly two fibres of cocoon silk by means of shellac, so that they cross each other at right angles. Push the cork slowly into the back of the eyepiece until the two threads are plainly visible without straining the eye. The clamping screw is an ordinary type of electrical terminal. A little peg *p* (Fig. 784), fixed underneath the clamp, fits into a recess in the square table and prevents the former from rotating round *s*₂. The

clamp can be readily moved to allow the telescope to come round.

THE INDEX AND OTHER ADJUSTMENTS.

A pointed piece of brass, *q*, is attached to the rotating table to indicate the angle turned through. For accurate work, *q* must be replaced by a vernier. The prism may be fixed on the table with soft wax. The butterfly nut *t*, which should press against a washer, must only be tightened sufficiently to prevent shaking, and the telescope table must be evenly bored so that the central hole fits the bolt *x* exactly. The arm *g* and the square table with its guide *v* ought to be bored at one and the

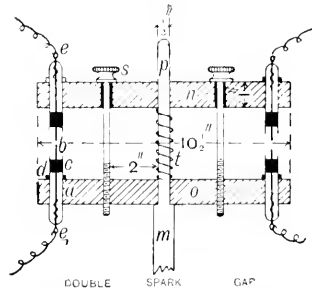

Fig. 785.—DOUBLE SPARK GAP.

same time. For stability, large pieces of lead could be attached underneath the table. The screws in the diagram indicate permanent junctions. Glued junctions can be substituted in suitable places. Hollow prisms for liquids may be made by grinding the edges of three glass plates with turpentine and emery paper until they are bevelled, and then cementing the bevelled edges. The three may then be cemented on to a base, while a small glass plate placed over the top will prevent evaporation.

MAKING SPARK GAP.

Take two squared rods (Fig. 785) $10\frac{1}{2} \times \frac{3}{4} \times 1$ " square, and bore the four holes indicated through both at the same time. Let the two faces which touch be opposite to each other in the finished article. The glass tubes of the terminals must fit the end holes stiffly. If they work loose, little indiarubber rings as at *d* may be fitted.

The top rod *n* must work loosely on the screws *s* and rod *p*. The spring *t* must be very strong; it should just be possible to compress it with the fingers. The terminals are made as follows: Take a piece of $\frac{1}{4}$ -in. glass tubing, cut off four equal lengths, each over 2 in. long, and melt one end of each in a blow-pipe flame

wire to form a plug *c*, the projecting part of the wire *b* can any time be adjusted by warming the end of the tube. The terminals are all made in the same way. A small piece of paper with the name of the metal of the wire may be introduced into the tube before the end is sealed up. The rods *n* and *o* may be soaked in melted paraffin wax. The secondary terminals are connected to *e* and *e*₁.

MAKING HELIOSTAT.

On the base *l* (Fig. 786) is hinged at *r* a smaller base *k* which may be inclined and clamped at any angle up to about 60° with safety. The clamping is done by the thumbscrews *h* and the slotted brass bar *g*, which is in the form of a curve, having its centre at *r*. On *k* a fairly good American clock is clamped, and *k* is pierced to allow the clock to be wound from underneath. The hands are taken off, and on the hour axle is fitted the wooden cylinder *c*. The latter is furnished with an axle *f* (see Fig. 787) which bears in a hole in the brass arm *j*. *c* will make one rotation in 12 hours: from a groove, however, a band passes to the bigger pulley *e*₁, which has twice the diameter of the grooved part of *c*. In consequence, *e* will turn round once in 24 hours. The mirror is carried on a steel axle *d* which bears on a small metal plate screwed to *k*, and the pulley *e*₁ is firmly fixed to this steel rod, which may be a stout knitting needle. On the axle *d* is also soldered a small collar *n* for the arm *j* to press on sufficiently to prevent vibration. It will be seen from the plan that the mirror and its axle can be easily removed for cleaning, etc., on raising up *j*, as it is only kept in position in the slot *p* by the band *m*, which may be indiarubber.

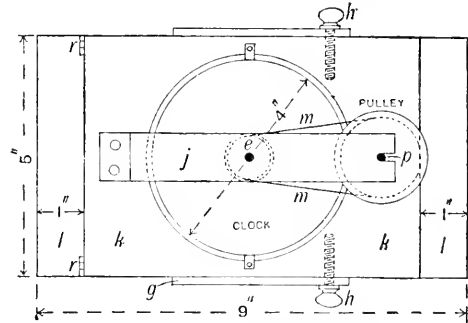

Fig. 786.—PLAN OF HELIOSTAT.

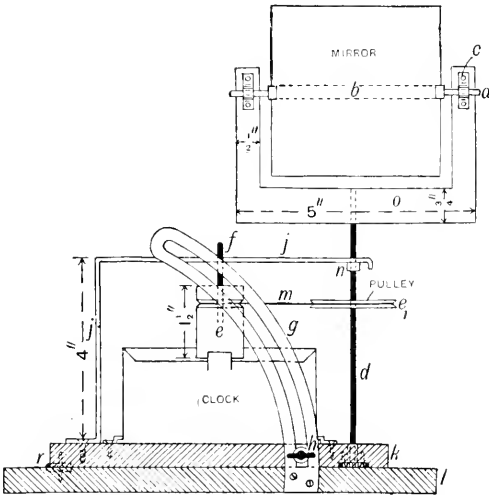

Fig. 787.—ELEVATION OF HELIOSTAT.

until it nearly closes up. Round one end of a piece of wire *b* twist a piece of platinum wire, leaving about 1 in. of the latter free. Solder the two, using resin as a flux. The platinum wire must now be pushed half-way through the nearly closed end of one of the glass tubes, and the projecting part of the platinum made into a loop. If a piece of marine glue or some similar substance be melted round the

back, or silvered side, can be used.

ADJUSTING HELIOSTAT.

The base *l* is placed with its length accurately north and south, by noting the position of the sun at noon, or, less accurately, by using a compass needle. The base *k* is inclined at an angle equal to 90° minus the latitude of the place of observation. Then *d* is parallel to the earth's axis. Place the mirror so that it faces the sun and reflects the rays in a line with the axle *d*. The clock will now keep the mirror facing the sun, and the reflected ray will be constant in position. By means of another mirror the reflected rays may be sent in any desired direction. An alternative method is to have *c*₁ four times the diameter of *c* (or rather the grooved parts must have that ratio), and then any reflected ray from the mirror will be constant in direction. This method is, for most purposes, not so convenient as the first one mentioned. It is necessary, however, in taking photographs of the sun.

MAKING SIMPLE ARC LAMP.

The rods *a* and *b* (Fig. 788) are 1 in. by $\frac{1}{2}$ in. at the ends, but are made to cross like a pair of scissors, therefore under *a* is placed a $\frac{1}{2}$ -in. wooden washer *c*. The screw *d* fits loosely in *a* and *b*. The spring *e* must be like the one for the spark gap. The arc may be struck by squeezing *a* towards *b*. The brass carbon carriers *f* and *g* turn round screws *u* and *o*, and are clamped by thumbscrews *l* and *m*. *h* and *k* are springy brass straps riveted to *f* and *g*, and the carbons should be grasped stiffly by these straps. The terminals to which the current is brought are *s* and *t*. These are connected by flexible copper wires (No. 16 or thicker) to the brass carriers at *q* and *r*. The wooden upright *p* can be soaked with paraffin wax. This arc may be used either vertically or horizontally. With alternate currents the carbons should be of equal diameter. Fig.

789 shows the plan, the lettering being the same. The arc requires about 40 volts, and a resistance of some kind is necessary.

CONCLUDING REMARKS.

Nothing has here been said concerning the purely photographic uses of the spectroscope, such as testing the suitability of plates and screens for orthochromatic and three-colour work, ascertaining the safety of dark-room lights, etc. These subjects

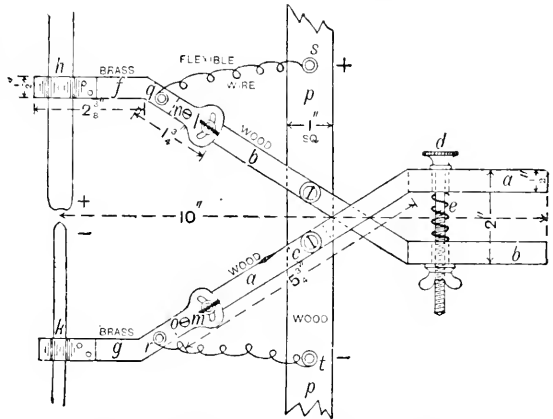

Fig. 788.—ELEVATION OF SIMPLE ARC LAMP.

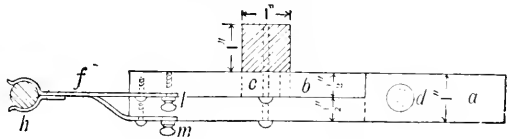

Fig. 789.—PLAN OF ARC LAMP.

have already been sufficiently alluded to elsewhere. The aim of this section has been rather to give a comprehensive view of the various methods in which spectrometric examinations are carried out, and the remarkable impetus given to different scientific investigations by the aid of photography. The practical instructions for making many of the instruments employed for this purpose will, it is thought, prove widely serviceable.

MONUMENTAL WORK.

INTRODUCTION.

FEW persons have more reason to be grateful to photography than the monumental sculptor, who makes use of it in various ways to aid him in his work. Not only is every completed statue or monument photographed before it leaves the studio, but at every stage in its evolution, from the first clay model to the finished marble, a photograph is taken and carefully indexed. In this way a complete record is kept of every piece of work, forming a valuable and interesting study to the sculptor and the architect. The absolute accuracy of such records is essential, truthfulness of rendering, coupled with proper relief and solidity, being indispensable. The latitude and novelty in lighting allowable in portraiture would here be quite out of place. The sculptor does not wish his work flattered or improved upon, neither does he desire its beauties to be hidden or lost.

SPECIAL TREATMENT OF DEFECTS.

At the same time, it will occasionally happen that the figure or monument may possess certain technical defects which it may be advisable to subdue. A stone may not be cut absolutely true, and this fault will be rendered with greater prominence in the reduced image. The material may possess certain veins or markings which to the trained eye may betray too clearly its quality; these will, of course, need to be removed. Or, again, a figure may appear too stunted, or certain features displeasing, and this may permit of either alteration or modification. Such, however, are the exceptions, and should only

be attempted by the experienced worker, or the remedy will probably prove worse than the disease.

STORING THE RECORDS.

In all large establishments these photographic records are kept in considerable quantities, so that duplicates may be sent out at any time. The prints may be either mounted or unmounted, but the latter is usually preferred owing to facility of postage and economy of space in storing. Where they are mounted, it is usual to enclose them in a sort of portfolio in sets of twelve, on the outside of which is written the name of the subject, its distinctive number, and the details of construction, price, etc. Where unmounted prints only are kept, they may be simply placed between two stout white boards, half an inch larger each way than the photographs, and held together with a rubber band.

SUITABLE PRINTING PROCESSES.

As nearly all the work will represent stone, the print should be one conveying the best impression of that material. Brown and similar tones are therefore unsuitable. The process which best fulfils these conditions is undoubtedly the platinotype, the only thing which may be urged against it being its greater cost. The next most suitable process is the bromide, which is more convenient when a number of prints are required from one negative. It also presents so much choice of surface: pictures having an extreme amount of detail may be printed upon the glossy or enamel variety, while

for general work the ordinary smooth grade paper may be employed. The carbon process is unsuitable on account of its cost, its chief recommendation being that of permanency, which as a rule is, in this case, not of paramount importance.

THE NEGATIVE.

The class of negative required for this work is one having a good range of gradation, but chiefly in the lighter tones. As a general rule, there are no deep shadows to consider in these subjects, but the differences of tone in the lighter portions are so slight that every care must be taken to secure sufficient contrast in those parts, even at the expense of the shadows. It must not be understood that a hard negative is desirable; but seeing that the light portions are those of chief importance, it is essential that a plate should be used which will give good contrast, while the negative is kept fairly thin, otherwise the delicate gradations will be buried. Something will, however, depend on the subject. With a statue or an elaborate piece of carving this will be more important than with a plain headstone. In the latter case considerably more intensity in the lighter tones will be allowable. It goes without saying that the negative must be as sharp as possible, and this sharpness should extend through the various planes of the picture. Too much depth of focus is, however, not advisable, as it tends to destroy roundness and relief. An absence of colour in the negative is preferable, as a better idea of the exact gradation is obtainable and its printing qualities in different processes may be more easily gauged.

APPARATUS REQUIRED.

The apparatus used should be of a firmly-made, rigid and accurate description, so that when set in any position it may be relied upon to remain undisturbed by other operations which may be going on. These remarks apply particularly to the rising front, swing back, focussing fittings and tripod head. As the camera will have, on occasion, to be taken into

awkward positions, it must also be as portable as is consistent with the foregoing requirements, but on no account should accuracy be sacrificed for the sake of portability. A square bellows camera is preferable for some work, but is less portable. Well-made conical bellows cameras, however, are now so strongly and accurately put together that there is little need to adopt the square form. Provided only a slight taper exists to the bellows, no difficulties should arise through its use. The ordinary tripod head with screw is preferable to a turntable for this work. The camera should be capable of a fair amount of extension, say about twice the longest side of the largest plate it is required to cover. Greater extension than this is seldom required. With regard to size, either 12" × 10" or whole-plate will be found the best. Smaller pictures are not of much use commercially, except perhaps in the case of plain headstones.

SPECIAL APPLIANCES.

There are not many special appliances made for this kind of work, but those are important. First comes the stand. The ordinary tripod is frequently too short for this purpose. A stand capable of raising the camera at least 5 ft. is necessary. The best plan is to provide two stands, one rising to 6 ft. and the other to 4 ft. 6 in., for the taller apparatus will be found extremely awkward when used only 3 or 4 ft. from the floor, as may be required. Very often the camera may need to be raised 10 ft. or even higher, but in this case it should be screwed to the top of a pair of steps or on a plank placed across some high trestles, a second plank being placed below for the operator to stand upon. The advantage of the latter method lies in being able to move the camera easily in a direction parallel with the object. A source of considerable trouble with stands is their liability to slip, and, unless some method of fixing to the floor is available, it is best to brace the legs together with a cord or strap, and in some cases even to weight it as shown by Fig. 790. Perhaps the most important piece of apparatus is the tilting table.

This is intended for employment when floor stones or carved ceilings have to be dealt with. There are several kinds now in the market (see, for example, Fig. 113, p. 54), but a simple appliance may easily be made by hinging two boards together, as shown by Fig. 791, and fixing at a proper distance so as to bring the two

to see at once whether the frame or the base requires alteration. The plumb indicator should be attached to the side of the back frame. A reversing prism or a mirror inclined at an angle of 45° may be used instead of a tilting board if desired. For small work, with a light camera, the tilting stand shown by Fig. 792 is very suitable.

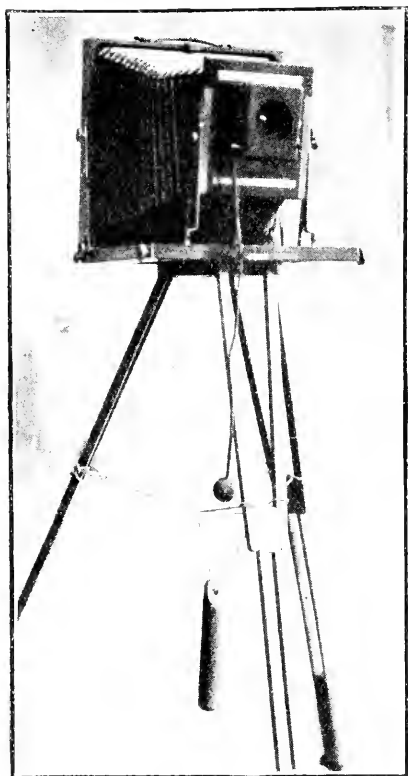

Fig. 790.—WEIGHTING THE STAND.

THE RULED FOCUSING SCREEN.

The only other special appliance is the focussing screen. For the sake of readily detecting any distortion of the lens and ensuring the rectilinearity of each part, as well as providing an aid in composing the

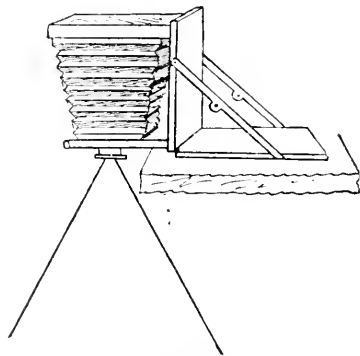

Fig. 791.—TILTING BOARD OR TABLE.

boards at right angles, with rule hinges. Focussing and other manipulations are occasionally awkward to manage when using this, and a lock attachment to all extension screws is essential, otherwise their position is very liable to change. The camera should further be provided with a level and plumb indicator. The level should be attached to the base of the camera so that any alteration of the other parts may be kept distinct. If it is fixed to the sliding frames it will be difficult

picture to the best advantage, a ruled focussing screen is extremely useful (see Fig. 793). This consists of an ordinary ground glass screen, on the reverse side of which lines are ruled with a diamond, exactly the same distance apart. The glass is then turned and a second set of lines ruled at right angles, so that the screen is divided into squares. If each measures half an inch each way, this screen may also be used as a means of estimating the scale of any portion of the image by noting how many of these squares are filled by the part under consideration. If preferred, the lines may be made with a finely pointed pencil or with ink on the ground side of the glass.

BACKGROUNDS.

The choice of backgrounds for this work is rather limited, as, generally speaking,

the subjects are light, and require a dark background to bring them into proper relief. The background, if on canvas, should be stretched on a frame or weighted so as to hang free from all folds or creases. As it usually has to be placed in all sorts of odd places, it is a decided advantage to have it as portable as possible. Fig. 794 shows a suitable arrangement, which may be readily put up or taken down and placed in various positions. It consists of a wooden frame, in the centre of which is stretched a sheet of red baize, or sheeting painted with distemper. The latter is the best, as the red baize, unless put well out of focus, will show a very

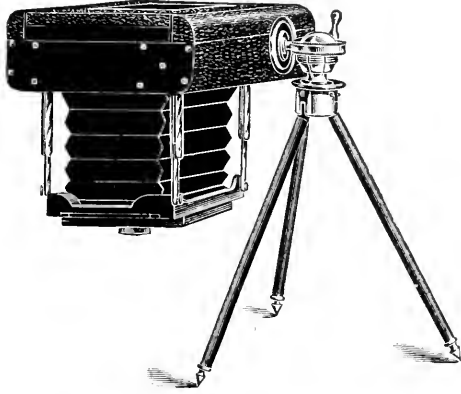

Fig. 792.—JOINTED TILTING STAND (Thornton-Pickard).

irritating grain all over it, which will detract from the subject and, in some cases, even spoil the outline where it contains any fine detail. Moreover, the roughness of the surface easily catches the dust, which is always much in evidence in a sculptor's studio. A good-sized piece of sheeting painted deeply with a mixture of lampblack and size will be found best, since it may be painted again as soon as soiled, and will not so readily take the dust. The background should be kept rolled up painted side inwards. When photographing sketch models in clay the background may be much lighter, in proportion to the tone of the clay used. With bronzes a light grey background is most suitable, such as is generally em-

ployed for portraiture. It should be borne in mind that considerable variation in the tone of the background may be made by turning it either towards or away from the light. The difference, however, will be very slight in the case of the dark backgrounds. It frequently happens that the surrounding work will not allow of the

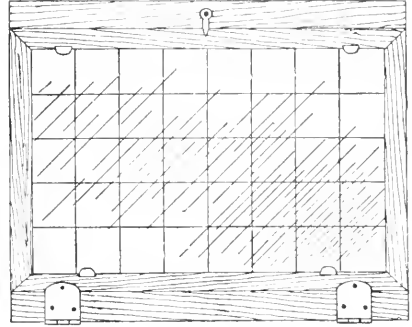

Fig. 793.—RULED FOCUSING SCREEN.

erection of a background, and, as a consequence, other objects come in and spoil the outline. In such cases these must be removed in the negative, either by cutting away the other portion of the picture, or

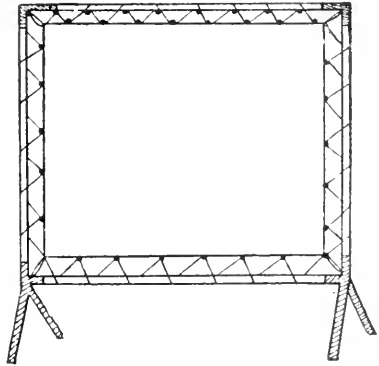

Fig. 794.—PORTABLE BACKGROUND.

else by blocking them out with opaque paint or varnish, the former giving a black background and the latter a white one. These same methods must always be employed when either an absolutely black or white background is desired.

LIGHTING THE SUBJECT.

The photographer is practically tied down to one kind of lighting, fancy effects being, as a rule, out of the question. Occasionally a piece of work has to be photographed in such light that it will have the same appearance as when fixed in its proper position. For this purpose some means of controlling the light at close quarters is necessary. In a small sculptor's studio the light is usually well under control, and probably little beyond the usual blinds will be necessary, but in large buildings the light can generally be controlled very little, and a portable head

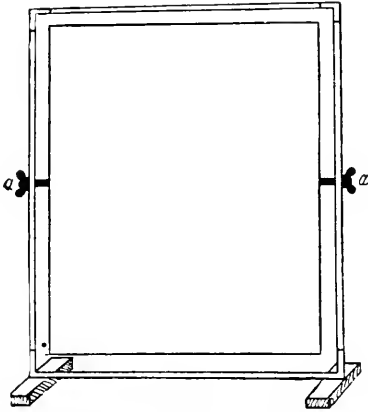

Fig. 795.—ADJUSTABLE REFLECTOR.

screen, very similar in principle to that shown by Fig. 605, p. 474, will be indispensable. It consists of an upright support, which may be of ordinary iron barrelling, containing a rod enabling it to be raised to various heights and clamped by means of a thumbscrew. The screen proper consists of a light wire frame over which are stretched two thicknesses of white muslin. Hinged to this frame are two hanging flaps, which may be folded out so as to cover a greater area. Some sheets of paper may be laid on the screen when less light is desired, while extra frames may be hung on and suspended as required to cut out the light from other directions. These are best of opaque paper. As regards the direction of the light, it should in most cases strike the figure at

an angle of 45° ; but while this forms a good general rule, no exact directions can be given for the precise admixture of front, top and side light. As so much will depend upon the taste of the operator, it is useless to say more than that, bearing in mind that side and top light give relief and front light softens or flattens if used to excess, the operator should experiment with different degrees of each until the desired effect is obtained. Since it is the lighter tones which have to be rendered, the contrasts may be somewhat severer than would be allowable in ordinary portraiture. This remark only applies to photographing marble or plaster; in the case of bronzes the contrasts should be more subdued. White marble does not photograph as easily as clay, so that, wherever possible, the clay should be chosen for preference.

REFLECTORS.

In addition to the head screen just mentioned, some reflectors will usually be needed. The pattern shown by Fig. 795 will be the most effective. It turns upon the pivot *a* so as to throw the light upwards if desired. It is not likely to be necessary to throw the light downwards; but it must be borne in mind that light leaves the surface at the same angle at which it strikes, so that the reflector must first of all be placed in a position to catch as much light as possible, and then to throw the maximum amount in the direction required. Such reflectors are used for the general effect, but occasionally a little local lighting will be needed. In such cases it may even be permissible to employ a mirror. Difficult corners or angles, or ornamentation shaded by projecting upper portions, will sometimes photograph a black mass utterly void of detail under normal conditions. A looking glass may then be arranged in such a position as to catch a fair amount of light—not direct sunlight—and reflected only on the dark portion, a box serving to prop it up at the desired angle. Local reflection can only be carried out with polished surfaces, or, of course, the ray will be too diffused. This power needs to be used

with considerable discretion, or it may be greatly overdone, and result in very false effects. The reflected light must only be just sufficient to bring it up to the general tone. The method is, perhaps, most applicable when dealing with bronzes or dark subjects. In all cases it must be remembered that a dull surface is essential for the proper rendering of tones.

Focussing.

The focussing of the subject, although a simple matter, needs to be done with extreme care. Bearing in mind that the best definition with the largest stop is desirable, the focus should first be fixed for a point about one-third into the picture. In order to explain this, imagine that the subject consists of a certain series of

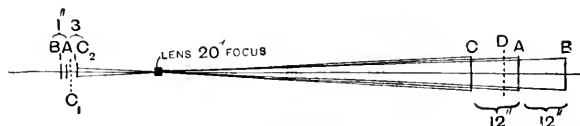

Fig. 796.—DIAGRAM ILLUSTRATING CORRECT METHOD OF FOCUSING.

planes, as shown in Fig. 796, all of which have to be more or less sharply rendered. Now the natural inclination would be to focus a point midway between these planes, under the impression that definition would be spread equally in both directions on inserting the stop. Such, however, is not the case. As the object draws nearer the lens, the image is formed farther back in proportion. That is to say, the point A will focus at A_1 , the point B at B_1 ; but the point C will come to a focus at C_2 and not C_1 , an equal distance from A_1 . The plane which focusses at C_1 will be point D, so that, if a stop is inserted, the improvement in definition will merely spread towards those two points, and the nearest point, which should be at least as sharp as any other part, will be out of focus. If, however, a part slightly nearer than A is taken, then the points B and C will both be sharply rendered. To ascertain the most effective stop to use, try them one after the other and note the effect. Supposing a lens of good quality is being employed which covers the plate

properly at full aperture, the size of the stop will be entirely dependent upon the depth of focus necessary, and can only be determined in the way described. Backed plates of ordinary rapidity should invariably be used. Rapid plates, giving as they do less latitude in exposure and weaker contrasts, are, generally speaking, undesirable.

EXPOSURE.

The exposure, as a rule, will be much less than for ordinary subjects, and, as the scale of intensities between light and shade is a short one, it must be given with accuracy to ensure good results. The novice cannot do better than employ one of the exposure meters referred to in the section on Exposure, where a full explanation of their use will be found. As

a rough guide at commencement, the exposure may be the same as indicated for portraits in the tables A and B on p. 95 when the monument is photographed in a well-lit studio. Most of the plate makers now issue rough guides as to exposure and some means of testing the power of the light. No pains should be spared to obtain a correctly exposed negative, since this is a long way towards success, and saves endless work afterwards. It is best to make exposures out of doors in a good light when first starting the work, and when proficient, to attempt interior exposures. It should be borne in mind that the exposure will in some measure depend upon the colour of the subject, and a few trial pictures may be taken of different materials, using the same plate, stop and light, and giving the same exposure. Broadly speaking, short exposures (*i.e.* exposures less than the normal, or that indicated by the meter) will give greater contrast, and longer exposures less contrast. These facts will serve as some guide, when the negative is complete, as to whether

the exposure has been correct. Another very good indication is the penetration of the image through the film. For example, if the picture can be seen on the back or glass side only, it is over-exposed; if on the film side only, it is under-exposed; and if on both sides it is usually correctly exposed.

DEVELOPMENT.

Any of the developers used for ordinary work may be employed, but perhaps the least suitable is metol. As the subject is not a movable one the exposure can easily be accommodated to the developer, so that an extremely energetic reducer is unnecessary. Even the now old-fashioned iron developer, or ferrous oxalate, can be used, but, as simplicity is a consideration, it will perhaps not recommend itself to the modern photographer. Hydroquinone may be used, either with the caustic alkalies, soda hydrate or potassium hydrate, or with the carbonates of soda and potash. As, however, it is somewhat inclined to give hard results when used with a weak alkali, the soda hydrate is perhaps the best, but in extreme cases, where a contrast has to be forced up in the lighter tones, such as when photographing a bas-relief, the other salts may be used. In early work, at any rate, and until some little experience has been gained, it will be best to employ the time or factorial method of development (see p. 115). Probably the best developer for all-round work is pyro-soda. Satisfactory formulæ for this and other developers will be found in the section on Development.

WORKING BY ARTIFICIAL LIGHT.

Occasionally this work has to be done in dimly-lighted rooms, or at night, and in such cases artificial illumination must be used. The best illuminant is electric light. Either an arc or an incandescent lamp may be used, since the subject permits of long exposure. A good duplex paraffin lamp or incandescent gaslight may be employed with good results. For larger subjects, magnesium flash-lamps, either worked by a pneumatic pump or ignited electrically, will be found best. Full par-

ticulars of these will be found in the section on Portraiture. Harsh shadows must under all circumstances be carefully guarded against, and therefore, when using such brilliant illuminants, the light should be made to shine through a sheet of oiled linen or fine ground glass. The precise number of lamps necessary and the amount of powder used will depend on the size of the subject. Flashlight cartridges are also very satisfactory.

DODGES.

In photographing working castings trouble is often caused by markings, and also by the light tone of the subject. It will be found to lead to a much more successful result if, when possible, the cast is clayed over. In certain large work it occasionally happens that, in order to get the best effect on the principal points, certain other parts are thrown into awkward shadow. Or it may be that, at the point of view chosen, some outlines appear incorrect. Now for the ordinary photographer to attempt to remedy these by touching-up might be a risky proceeding, but there cannot possibly be any danger in the sculptor himself making the necessary corrections before the photograph is taken. A little distemper mixed up and a few brushes will be all that is required. In this way high lights may be painted in with white, shadows deepened or outlines corrected. The colour can be readily removed afterwards. Polished surfaces may be dulled by dabbing over with a little putty or by rubbing down with whitening and water.

LETTERING AND TITLING.

Lettering often photographs to practically the same tint as the stone, and cannot be seen. Take, for example, the case of lead letters on grey granite. These letters, being of a blue tint, will be quite lost in the negative, although apparently of less intensity. By painting them carefully over with red paint they may be made to come out clearly. Some workers prefer to show the title of the picture on their prints. This may be done on the

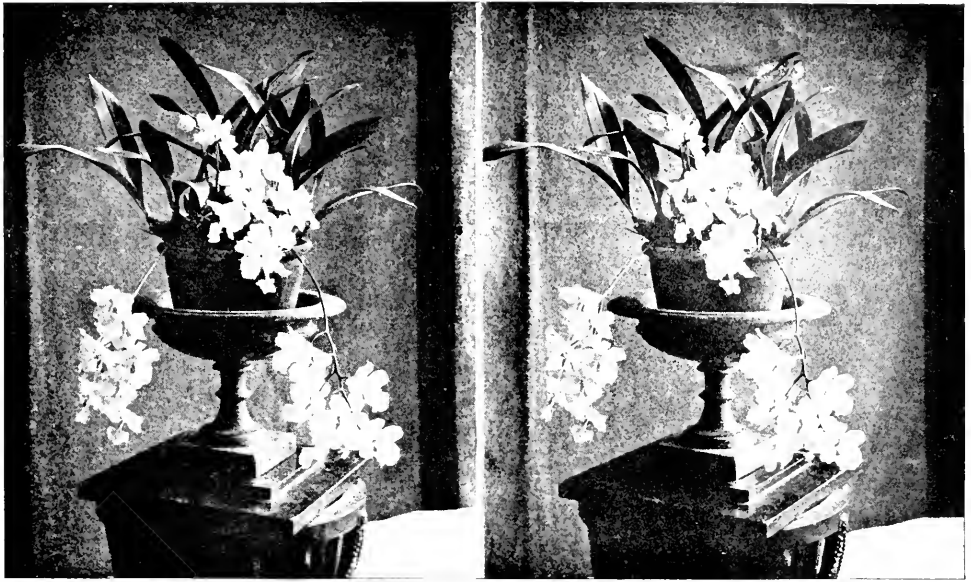

STEREOSCOPIC FLOWER SUBJECT PROPERLY LIGHTED,



A GOOD COMPOSITION FOR STEREOSCOPY, BUT BADLY LIGHTED

negative in either of three ways: (1) By writing backwards with opaque ink or a sharp scraper. (2) By using a rubber stamp set up to print backwards; or (3) by writing in the ordinary way in opaque ink on a small piece of transparent paper or gelatine and attaching it ink side to the film. Of the three methods the second is the simplest and most effective, although unsuitable for very small work. Printing outfits for the purpose can be obtained of any photographic dealer or rubber stamp maker.

CORRECTION OF DISTORTION.

It sometimes happens that, say, a headstone has to be photographed in such a position that it appears in the picture to be falling backwards, or it may be that this is actually the case. The defect may, however, be remedied in the following manner. First make a transparency by contact, and, when finished, set this up in a well-lighted window with a clear view free from any obstructions, such as trees, etc., and focus through the camera an image of the same size. A top-room window having a clear view of the sky is best for the purpose, or failing this the camera

may be placed on a board, as shown by Fig. 456 (p. 322), and pointed to the sky. When the image has been focussed, proceed to swing the back of the camera until the two lines are rendered vertical on the screen. The lens is now stopped down until an aperture is found small enough to render the whole of the image sharp at the same time. Where the stone is leaning a great deal the fore-shortening may be apparent in the finished picture, but, as a rule, it is not noticeable

CONCLUDING REMARKS

In photographing low-relief, the aim should be to obtain a negative with good contrasts. The light should be kept to the extreme side, and as little front light as possible allowed to reach the subject. Artificial light is especially suitable, as cast shadows are easily avoided. Whenever the contrasts in the finished negative are unsatisfactory, resort may be had to intensification or reduction. The former is, however, a dangerous remedy in such work, since the lighter and more delicate modelling is almost sure to be lost. If used, it should be only to a very slight extent.

ASTRONOMICAL PHOTOGRAPHY.

THE ASTRONOMICAL TELESCOPE.

IN its simplest form an astronomical telescope (Fig. 797) consists of an object glass and an eyepiece. The former, a convex lens, gives a very small real image, $a b$, and the latter, another and more convex lens, enlarges this image, giving a virtual one. The parallel rays A_1, A_2, A_3 come from one point on the sun's surface. This assumption of parallelism will be valid because, since the sun is over 90,000,000 miles away, and in coming that distance the rays only

sun, and b of B . The distance between a or b and the object glass L_1 is equal to the principal focal length of L_1 .

INVERSION OF IMAGE.

It will be noticed that the small real image of the sun at $a b$ is inverted. The inversion is of no account even for eye observation, because in the heavens there is nothing to define which is "top" and which is "bottom"; not as on the earth, where we instinctively define motion towards its centre as "down" and away

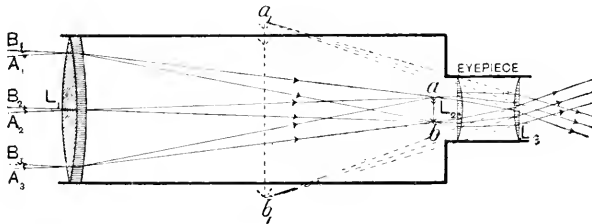

Fig. 797.—REFRACTING TELESCOPE.

diverge to the extent of the angle subtended by A_1, A_2 , the angle of divergence between any two of these rays must obviously be infinitesimal. If B_1, B_2, B_3 are rays coming from another point on the sun, they will make an appreciable angle with the A rays. If B were at the end of a diameter of the sun and A at the other end of it, the angle between the directions of A and B would be $23''$. (A circle is divided into 360 degrees, each degree into 60 minutes, and each minute into 60 seconds.) The A rays will come to a focus at a in the upper part of the tube, the B rays at b in the lower part, a being the image of the particular point A on the

as "up." This enables astronomers to avoid the insertion of an erecting lens which would entail a serious loss of light, although in a terrestrial telescope it is necessary. The real image at $a b$ must now be enlarged, and this can be done by placing the eyepiece at less than its focal distance from $a b$. By the focal length of the eyepiece is meant the focal length of the combination of lenses, of which a good eyepiece always consists. The system illustrated is termed a "Ramsden's" eyepiece. This forms a virtual image $a_1 b_1$, and must be so adjusted that $a_1 b_1$ is seen at the distance for distinct vision. What actually happens is that the lens

L_2 bends and converges the cone of light coming from a by a certain amount, and as these rays fall on L_3 they are bent and converged still more. The total converging effect of the two lenses is only sufficient to make the rays less converging. To the eye, therefore, they will seem to come from a point a_1 , behind the real image. This bending of the rays is the essential factor in enlarging the image.

DATA FOR EYEPIECE.

The calculation of the focal length of the Ramsden's eyepiece will now be considered. Let ab (Fig. 798) be the real image formed by the object glass. It will simplify the calculation if the eyepiece be placed so that parallel rays emerge at κ . Then ab is at the principal focus of the eyepiece. The distance between L_2 and L_3 is equal to two-thirds of the focal length of either. Lens L_2 gives a virtual image $a_1 b_1$ of ab ; $a_1 b_1$ may be considered as a secondary source of rays, for if lens L_2 were removed and a point of light placed at a_1 the cone of rays from that point would produce a similar beam of parallel light at κ . This means that $a_1 b_1$ is at a distance from L_3 equal to the focal length of the latter. Let f represent the focal length of either lens. Then $L_3 b_1 = f$; $L_2 b_1 = \frac{f}{3}$, and $L_2 b$ is the focal length of the eyepiece. By the formula

$$\frac{1}{L_2 b} - \frac{1}{L_2 b_1} = \frac{1}{f} \therefore L_2 b = \frac{f}{4}$$

The radii of the lenses are chosen so as to remedy as many of the defects of aberration as possible. For achromatism, the distances between the lenses should be one focal length, but in that case the lens L_2 lies at the focus of L_3 , and any dust or scratches on it would be magnified, spoiling the definition of the image of ab . When an interval of two-thirds of a focal length is taken between L_2 and L_3 , perfect achromatism is not much departed from. It may be mentioned, as interesting, that a low-power Ramsden's eyepiece makes a good focusing glass or magnifier.

THE OBJECT GLASS.

For the object glass a combination of two lenses is employed. As in a camera, the violet rays must be brought to the same focus as the red rays. A convex lens of crown glass and a concave lens of flint, cemented together by Canada balsam, are generally used. Theoretically, there is every advantage to be got by having the object glass as large and as thin as possible. The longer the focal length, the larger will be the real image formed at ab ; the thinner the lens is, the better will be its definition. If the diameter of the object glass be enlarged, more light will be received and converged, and the image at ab will be so much the brighter. But the practical difficulties of

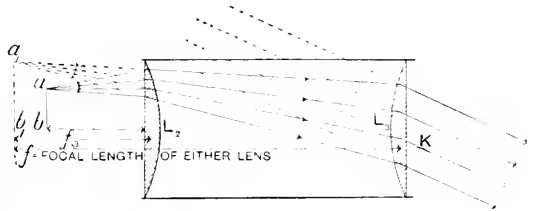

Fig. 798.—CALCULATING FOCAL LENGTH OF EYEPIECE.

preparing and mounting such large lenses soon place a limit on the available size. A large thin lens bends in the middle owing to its weight, the only remedy being to make the glass thicker. But this causes serious absorption of the entering rays, and nullifies the effect of having a larger receiving surface. Besides, it is a difficult matter to cast such a large piece of glass so that it shall have a uniform structure throughout and also be free from local strain. The troubles also, due to expansion, with such large masses of glass are serious, and with a longer focus a longer tube is needed for the telescope. This tube, moreover, must be rigid and mounted so as to point in any required direction.

REFLECTING TELESCOPES.

As metal mirrors are more easily prepared in large sizes than glass lenses,

they have been used in the construction of the largest telescopes. Sir John Herschel's telescope had a concave mirror which was four feet in diameter. Metal is, however, more subject to expansion errors than glass, and it is very difficult to mount metal mirrors so that the surfaces are without strain and truly convex. Little differences of curvature imperceptible to the eye produce a marked effect on the definition of the image. Even a piece of plane glass, for example, may

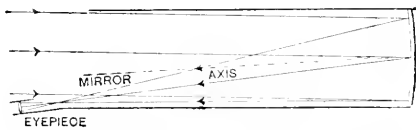

Fig. 799.—HERSCHEL'S REFLECTING TELESCOPE.

seem to have a uniformly even surface, but if a ray of light be made to fall on it and then enter the eye by reflection it rarely remains a distinct spot from every point of view. A great drawback in these telescopes is the presence of the apparatus for directing the reflected rays into

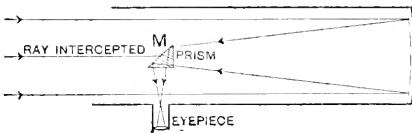

Fig. 800.—NEWTON'S REFLECTING TELESCOPE.

the eyepiece. This generally stops the rays which would otherwise fall on the centre of the mirror. In the diagram of the Newton telescope, Fig. 800, *M* represents a piece of plane silvered glass or a totally reflecting prism. Its interference with the rays can be easily seen. In later forms of telescopes, object mirrors have been made by grinding glass to the proper curvature and thickly silvering and polishing the ground surface. Mirrors do not seem to have been much favoured for photographic purposes, in spite of the fact that rays of all wave-lengths generally come to the same focus, although the case of the Crossley reflector used at the Lick observatory may be cited as an exception.

POSITION OF EYEPIECES AND CAMERAS FOR REFLECTORS.

In every case, the position of the eyepiece indicates where the camera should be attached, since the tube which carries the eyepiece can be made to support the camera lens. The eyepiece is always removed before attaching the camera. In the following diagrams, four methods of diverting the rays into the eyepiece are shown. Herschel's method of allowing the parallel rays to fall on the mirror at a small angle with the mirror axis (Fig. 799) can only be used with very large and long instruments. This is the simplest method of all. The real image formed by reflection is viewed at the edge of the tube, and the middle part of the mirror is used. In Newton's telescope (Fig. 800) the rays are reflected by a right-angled prism and form an image that can be viewed from the side of the tube. With such a prism the light is totally reflected and the image is very bright. Gregory devised the instrument shown by Fig. 801, in order to get the eyepiece in its usual position. The two mirrors may be made to compensate one another for errors of aberration. Cassegrain's form (Fig. 802), which is very similar in principle to Gregory's, has a rather better method of compensation for aberration.

THE TELESCOPE FINDER.

With the size of the telescope, that of the image given by the object glass increases. This means that the eyepiece views a smaller portion of it, and it becomes more difficult to point the telescope quickly towards any desired part of the sky. To the large instrument a smaller one is attached, termed a finder, whose axis is parallel to that of the larger one. Since the magnification of the finder is small, its field covers more of the sky. More objects are seen, and any one of them is more readily singled out. From what has been argued before, with regard to light from distant bodies, it will be evident that the telescope and its finder are both receiving rays from the same quarter of the sky, and if the mounting

of the instruments be accurate, a star seen in the finder ought also to be seen in a similar position in the larger instrument. The finder (F) is shown very plainly on the top of the telescope in the illustration on page 600.

ATTACHING THE CAMERA.

After the removal of the eyepiece the camera is fixed so that its lens is between one and two focal lengths away from the image *a b* (see Fig. 797, p. 594). An enlarged real image of *a b* is then focussed on the camera screen. In the case of the sun and moon the exposures may be rapid on account of the large amount of light received, and also because the bright images obtained are only enlarged to a comparatively slight extent. But from smaller bodies, such as Venus and Mars, much less light is received, and yet because their image is small it must receive a greater enlargement. A longer exposure is consequently needed, and, under these circumstances, the effect of the earth's rotation must be accurately eliminated.

EFFECT OF EARTH'S ROTATION.

Since the earth rotates once in twenty-four hours from west to east, all the celestial bodies seem to move at an equal angular rate in the opposite direction. Taking a stellar photograph is like photographing an object whilst the camera is being carried round on a rotating platform. If the camera were pointed to the stars and given no compensating movement, parallel trails would be imprinted on the plate instead of dots. To keep the camera fixed on the object it must be rotated at an equal angular rate in the same direction as the bodies are apparently moving, and, therefore, at a rate equal and opposite to that of the earth's diurnal rotation. This is the arrangement which facilitates prolonged observation through an eyepiece. To explain the eliminating device adopted, the method of locating the positions of the celestial bodies will be first considered, as far as is necessary for the present purpose.

ALTITUDE AND AZIMUTH.

There are three different methods of fixing the directions in which a person must look, to find any given body in the sky. Only two will be treated here. The first method is to consider its position with regard to the place of observation. All measurements must, naturally, be angular. The telescope is fixed horizontally and pointing to the south, *i.e.* in a

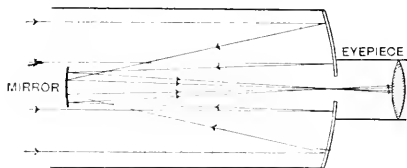

Fig. 801.—GREGORY'S REFLECTING TELESCOPE.

vertical plane which passes through the sun's centre at mid-day. Any horizontal rotation from this position is termed Azimuth, and any vertical rotation, Altitude. But it is evident that measurements taken on this plan are of restricted use, only applying to the observer's locality, since both the horizon and the sun's direction at its highest elevation vary for different places on the earth. As the apparent motion of the heavenly

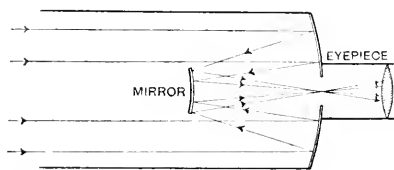

Fig. 802.—CASSEGRAIN'S REFLECTING TELESCOPE.

bodies alters both in altitude and azimuth, any mechanical arrangement for keeping a star continually in view in the telescopic field would be unnecessarily complicated.

THE CELESTIAL SPHERE.

In the second method, all measurements are referred to the centre of the earth, and thus the observer's position on the earth's surface does not interfere with subsequent comparison of the observa-

tions made. This system of measurement depends on the small magnitude of the earth's radius when compared with the distances of the bodies that are being observed. As a first illustration, consider the directions in which a couple of men standing side by side must look to see the same object at a distance of five miles. Certainly there is an angle ($\frac{1}{1100}$ of a degree approximately) between their lines of sight, but the two directions are for all

would take a year in travelling, the star's distance is termed a light-year. As far as position in the sky is concerned, the stars might all be at an equal linear distance away, apparently attached to the inside of a large imaginary sphere, rotating once every twenty-four hours (sidereal time) round the earth's axis. This imaginary sphere, once believed to be a reality, is very useful for reference, and is called the Celestial Sphere.

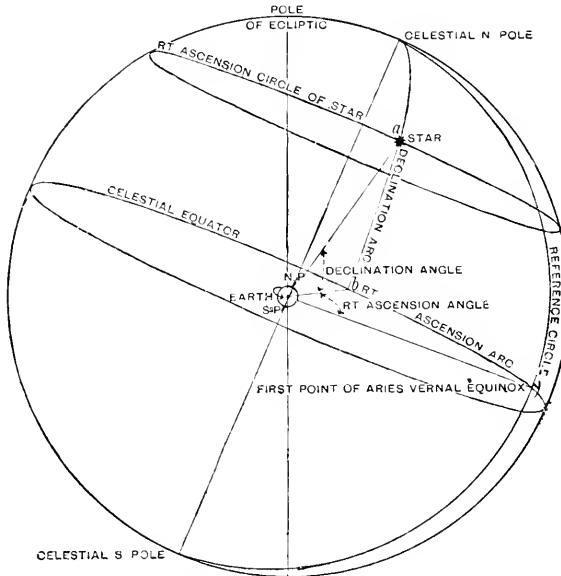

Fig. 803.—THE CELESTIAL SPHERE.

practical purposes parallel. Suppose now that two observers, one at the north pole of the earth and the other at the south, point their telescopes at the same part of the sun's surface, the angle between the directions of the instruments, since the sun is 92 millions of miles away, would be less than $\frac{1}{110000}$ of a degree. Now, multitudes of the stars are so far away that, instead of taking the mile as a unit of measurement, it is more convenient to take half the diameter of the earth's orbit, *i.e.* the distance from the earth to the sun. This unit is too small for the more distant stars, and their distances are reckoned in light-years. If the light coming from a given star to the earth

RIGHT ASCENSION AND DECLINATION.

If the telescope be fixed at right angles to the earth's axis, its directional line will trace in the course of one rotation of the earth a circle, called the celestial equator, on the imaginary celestial sphere. The first point of Aries, one of the equinoxes, lies on this equator. All measurements are referred to this point, and since the earth's time of rotation is constant, it reappears in the fixed telescope at regular intervals, termed sidereal days. A sidereal day is slightly less than a solar day, so that this system of time measurement would not do for ordinary purposes; all astronomical clocks, how-

ever, keep sidereal time. After an interval of one sidereal hour from the passage of the first point of Aries over the cross-wires, the telescope will be directed towards a point on the celestial equator $\frac{1}{24}$ of 360° to the left of that reference point. Evidently, the celestial equator may be divided either into degrees or sidereal hours, the latter system of division always giving the time since the transit of the first point of Aries. If the telescope be rotated round an axis parallel to that of the earth, through 15° to the right, the reference point will again come into view. Angular distance like this 15° , measured along or parallel to the celestial equator, is termed Right Ascension, and is only measured in one direction in sidereal hours, from the half of the great circle which passes through the two celestial poles and the first point of Aries. This is the circle which would be traced by the directional line of the telescope when rotated in a vertical plane containing the equinoxes. The circles of Right Ascension get smaller nearer the celestial poles. Angular distance measured vertically above or below the celestial equator is termed Declination, and is expressed in degrees. In the diagram (Fig. 803) the star at *a* has a Right Ascension denoted by *y b*, whilst its Declination is *b a* and is positive; *y b* and *b a* are each arcs of equal circles.

ELIMINATION DEVICES.

An equatorial telescope eliminates the earth's diurnal effect by its peculiar mounting. It is mounted so as to rotate on an axis which is parallel to that of the earth. In the diagram of the celestial sphere the two axes become coincident, as the earth is supposed to be a point. The telescope also independently rotates about an axis at right angles to the first one mentioned. Its centre of gravity is adjusted by sliding weights. The first rotation is in Right Ascension, the second in Declination. The plane of the second rotation may or may not pass through the middle of the mounting pier. Very often the telescope is fixed by its middle at the end of a horizon-

tal axle, and balanced by weights attached to the other end of the axle, the pier being directly under the centre of gravity of the whole movable system. Any parallel displacement of the rotational plane cannot be shown on the celestial sphere, because, again, the earth must be considered as a point. The two rotational movements are measured separately by means of verniers moving over two finely graduated circles, each placed at right angles to the axis of the rotation it is required to measure. The Declination circle *D* with its observing eyepiece is

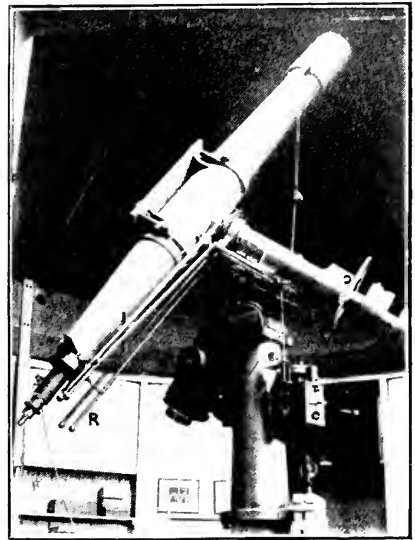

Fig. 804.—TEN-INCH EQUATORIAL TELESCOPE.

plainly seen in the illustration of the ten-inch equatorial (Fig. 804).

MECHANISM OF ELIMINATION.

An observer with an equatorial telescope, at whatever place on the earth he may be stationed, must be considered as being at the centre of the Celestial Sphere. Let him direct his instrument towards star *a* (see Fig. 803); *a* will apparently move along the circle shown, and this circle is parallel to the celestial equator. If the telescope, clamped for Declination, be driven round in Right

Ascension at the rate of one rotation in twenty-four sidereal hours, it will keep the star continually in the field. The motion is generally obtained by using a clockwork arrangement actuated by weights. This mechanism can be seen in Fig. 804. In ordinary clocks a pendulum and escapement is used to regulate the movement of the hands. This method is reliable, but the motion is not continuous. The wheels move by little jerks, owing to the sudden slip of the escapement wheel every time a cog is released. This would

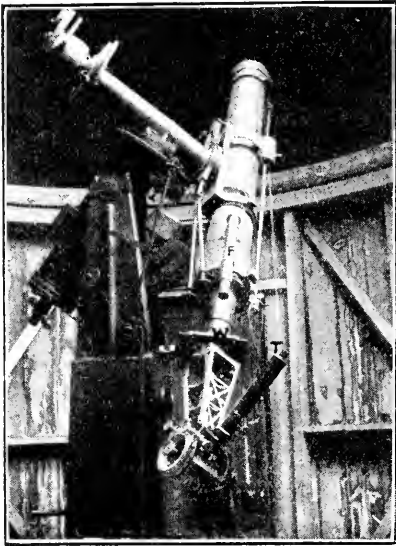

Fig. 805.—SIX-INCH EQUATORIAL TELESCOPE.

not do for photographic purposes, so the governing is generally done by a spring and friction.

ARRANGEMENTS FOR REGULATION.

If the regulation is not accurate the telescope will gain on or lag behind the star, and the tell-tale trail will appear on the plate. When long exposures must be made, as the regulation is rarely perfect, the observer makes sure that the image remains in position by keeping the star or other object on the cross wires of the finder. The latter must not be too small. Sometimes it equals the photographic

telescope in size. By the side of the telescope tube in Fig. 804 can be seen long rods *r* with knobs at the ends. By twisting two of these rods, which are furnished with tangent screws, small and exact displacements in Declination and Right Ascension can be given independently of the driving motion. The other two rods, one for each rotational movement, are for clamping and unclamping the telescope, since it would not do to introduce possibilities of vibration with such a large moving mass. In the illustration of the six-inch instrument (Fig. 805) at the lower end of the tube is seen a slide arrangement *w* for the spectrocope. When the latter is removed, it can be replaced by a camera, and an image may then be focussed on the screen as in ordinary photography. *t* is the spectrocope telescope.

LATER METHODS OF ELIMINATION.

As it is very difficult to avoid vibration while moving telescopes bodily, the eyepiece of the finder and the camera plate are given a compensating movement when the exposure is not too prolonged. In the case of a very long exposure it would not harm the plate to rapidly re-adjust the telescope when the bodies being photographed were likely to pass out of the field of the instrument. With other instruments, where the telescope tube is absolutely rigid, a mirror is used. Any part of the heavens may be reflected into the tube by a movable mirror having mountings like an equatorial. Such a compensating mirror is termed a heliostat or siderostat. A similar instrument is shown in Fig. 806. It is first set independently opposite any desired portion of the sky, and then the compensating motion is communicated by a tangent worm to a pinion which moves in Right Ascension. The small mass of the moving parts makes this system steady, and the adjustment is easy and rapid.

PHOTOGRAPHY OF THE SUN.

The sun is the nearest star to us, forming the centre round which the earth revolves in its orbit. As a consequence, it

has an apparent motion of travelling completely round the celestial sphere once a year. This motion must be added on to the apparent daily motion of the stars across the heavens. As the sun is such a powerful source of light, instantaneous photographs of it may readily be obtained. For an eight-inch image on a clear day the exposure is about $\frac{1}{500}$ of a second. Two records of the sun are now photographed daily at Greenwich. The sun's surface is continually changing in appearance, and the immense advantage of having reliable records that may be studied by a large number of observers at any convenient time is obvious. Formerly each observer had to record his impressions by sketches, which tended to vary with the individuality of the worker. It must not, however, be thought that a photograph is absolutely reliable. Owing to the varied chemical action of light of different wave-lengths, to inherent peculiarities of sensitised films, methods of development, etc., a photograph often looks very different from the appearance the object presented to the eye, and would of itself convey a wrong impression. These physical effects, though, can be judged and allowed for with far more certainty than could personal influences. But whenever possible, a description and sketch of the object as seen by the eye should accompany the photograph.

SIMPLE TELESCOPE FOR SOLAR OBSERVATION.

Small photographs may easily be taken with a telescope having an object glass of about 2 in. diameter, and with a focal length of about 30 in. With such a short focal length the image will not, of course, bear much enlargement. The size of the real image given by this object glass is a little over a quarter of an inch in diameter, which might be enlarged to about ten diameters for photographing. It may be as well here to caution beginners never to look through a telescope at the sun, unless provided with a few dark glasses to absorb a large percentage of the light. A very good instrument capable of giving much instruction and recreation may be

made on precisely the same lines as those described for the construction of a telescope for the spectrometer (see p. 581). The tube of the instrument may, in this case, be made of thick cardboard to enable it to be handled easily. The diameter and focal length of the object glass have been mentioned (2 in. and 30 in. respectively), and the focal length of each eyepiece lens, suitable to this object glass, would be about $1\frac{1}{2}$ in. The instrument will have then an enlarging power of 80.

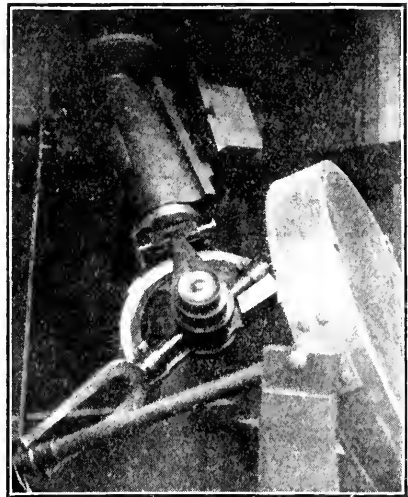

Fig. 806.—SIDEROSTAT.

CALCULATING MAGNIFICATION.

Magnification is easily calculated by dividing the focal length of the object glass by the resultant focal length of the eyepiece. From the diagram of the eyepiece (p. 595) it will be seen that the resultant focal length = $1\frac{1}{2}''/4 = \frac{3}{8}''$ and therefore magnifying power = $30''/\frac{3}{8}'' = 80$. With good refracting lenses, the magnification for visual observation may be taken approximately from 80 to 100 per inch diameter of the object glass. Thus a six-inch instrument has a magnification of about 500. With the same eyepiece, the size of the resulting image depends directly on the focal length of the object glass, and with a camera lens of a certain focal length placed at a constant distance

from the real image given by the object glass, the size of the image on the focusing screen has the same dependence.

STATE OF THE ATMOSPHERE.

One of the essentials for successful observation and photography of the heavens is a still, clear atmosphere. Not only must there be an absence of clouds, but the presence of wind near or above the earth is prejudicial to good photography. The twinkling of the stars must strike every beholder. It is due to variations of density in the atmosphere, whereby the rays are unequally refracted from their original direction. Were there no atmosphere, the stars would seem absolutely steady bright points. Of course, these effects of the atmosphere are more marked the thicker the layer of air traversed by the rays. For these reasons, Professor Pickering advocates the erection of observatories near the equator, out of the regions of the trade winds, and where the sun and large planets pass more vertically overhead.

THE SUN'S VISIBLE DISC.

The necessity of having pictures of the sun's disc, which are merely representations of the appearance of the surface, has now sunk into a position of secondary importance. Monochromatic photographs of its surface reveal its chemical state, and the analysis of small areas by means of the spectrometer tells far more of the local characteristics or the nature of any disturbances in progress. Still, as the apparatus for the two latter methods of observation is very complicated, requiring great care and skill for its successful use, ordinary changes in the sun are traced by the usual photographic methods. In the solar surface there are centres of violent disturbance forming great chasms, which are always changing in shape. These parts are termed sun spots, but they are so large at times that they would easily hold many planets like the earth. The sun rotates about its own axis, thus causing every part of its surface to be visible in turn, and the spots are seen to be really

great hollows, by the saucer-like appearance they possess when they get to the edge of the disc. The part of the sun appearing on a negative is not a picture of the extreme outside of the sun, but of that part called the photosphere, *i.e.* of the part which is at such a high temperature and pressure that it forms the source of the light radiation that reaches the earth. The telescope in common use at Greenwich, up to 1897, for photographing the photosphere, is only 4 in. in aperture, and the focal length of the object glass is 5 ft. The telescope and camera together are termed a "photo-heliograph." The image of the sun at the principal focus is about $\frac{6}{10}$ in diameter. The slowest photographic plates are employed, and the exposure is made by means of a slit pulled by a powerful spring, which, of course, gives equal exposure to all parts of the image. To avoid missing the photographs on dull days, common enough in this climate, similar instruments in India and Mauritius are engaged in taking duplicates. The measurement of the area covered by the sun-spots is facilitated by using a piece of glass ruled over with small squares, which can be placed over the photograph.

THE CORONA.

The coronal appendage, observed in eclipses, was at one time the subject of much discussion. Some astronomers thought it might be of terrestrial origin, but in 1871 Davis obtained a series of fine photographs at different stages of totality, and these agreed in every respect excepting that the shadow of the earth occupied different relative positions with regard to the corona. Colonel Tennant, at a station hundreds of miles away, secured six photographs agreeing perfectly with those of Davis. Photography, therefore, conclusively proved the solar origin of the corona. The light is so feeble that it can only be photographed at eclipses. The shape of the corona varies from year to year, as shown by photographs and drawings. Sometimes a large equatorial extension is seen. These changes in the corona, owing to the larger number of

records now available, are seen to vary sympathetically with the maxima and minima of sun-spot disturbance. The light it emits is generally described as pearly-grey.

HUGGINS' METHOD APPLIED BY
LOCKYER AND JANSSEN.

If a mixture of line and continuous spectra be passed through several prisms, the continuous part will get decidedly weaker, owing to dispersion. The lines, being caused by light of only one wavelength, cannot be dispersed, and therefore preserve their brightness. Thus, for example, the chromospheric spectrum can be observed in the daytime by using a tangential slit. Dr. Janssen employed

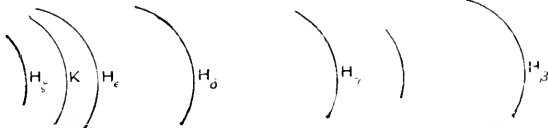

Fig. 807.—DIAGRAM OF A CHROMOSPHERIC SPECTRUM.

this method after the Indian eclipse of 1878. The slit is placed tangential to the photosphere.

CHROMOSPHERE AND PROMINENCES.

The Chromosphere, so called on account of its colour, is a gaseous envelope three or four thousand miles deep, surrounding the hotter part of the sun. Like the corona, it can be advantageously photographed at the time of an eclipse. It gives out a rosy light, which is supposed to be due to hydrogen, and has a bright line spectrum, consisting principally of hydrogen lines. One well-defined line arrests the attention; it has been called D_{β} , and as it could not be matched by any line in the spectrum of a terrestrial substance, the unknown element giving out that particular coloured light was called "helium," from Greek "helios," the sun. But, lately, a gas has been obtained from a mineral called "cleveite," which contained this line in its spectrum, by Sir W. Ramsay. Bruggerite also contains this element

RING SPECTRA.

In the case of such a faint object as the chromosphere, it is undesirable to employ a slit to receive the light. The chromosphere, at or near totality at the time of an eclipse, is a more or less complete ring of glowing matter. For spectroscopic work the slit and collimator lens may be dispensed with, since the incident light is parallel, and the chromospheric line is well defined, but a ring spectrum will be obtained, as shown by Fig. 807. To get a proper idea of such a spectrum, look at a well-polished ring, illuminated by a brilliant light, through a prism close to the eye; a continuous ring spectrum will be seen, having somewhat the appearance of a hollow cylinder. If a ring placed on

white paper be looked at, the colours will not come in the usual order, but as follows: Yellowish green, yellow, red, violet, indigo, blue, and green. This is because the ring will most probably be darker than the paper, in which case the spectrum is produced by the bright edges of the paper adjacent to the ring. The foregoing method of observing the spectrum, the principle of which was first enunciated by Fraunhofer, is extremely simple. The whole working apparatus consists of one or two prisms placed in front of the object glass of a telescope. This instrument, which is much employed in eclipses, is termed a coronagraph. (The corona is photographed along with the chromosphere.) The chromosphere acts as a slit, and needs no collimator, $H\alpha$, $H\beta$, and $H\gamma$ are represented by three rings, D_{β} by another, and so on. For comparison, line spectra may be made from these negatives by using a small strip of the ring spectrum and a cylindrical lens. Very often the object glass is corrected for photographic rays, when the focus must be found by photography.

SOLAR PROMINENCES.

Only some of the lines of any known element are given by the chromosphere. Three magnesium lines out of seven are known; two sodium lines out of eight; two iron lines out of two thousand, etc. The reasons for this have yet to be fully worked out, but it is probably a question of temperature and pressure. The prominences of the sun are masses of glowing gas, which stretch out for thousands of miles from the chromosphere. The ring spectra photographs

causing the collimator slit to move along the prominence, its hydrogen shape may be sketched. This method is in principle identical with that employed in taking monochromatic images of the sun. Other lines of the spectrum will indicate the distribution of their corresponding substances in these tongues of flame.

ATTACHMENT OF SPECTROSCOPE TO TELESCOPE.

The method of adapting the spectroscope to the end of the large telescope for solar observation is shown by Fig. 805. The collimator is attached to a sliding base similar in construction to the metal slide rest used with lathes. The base is capable of motion in two directions at right angles, and is adjusted by means of two fine micrometer screws, one of which is seen at the left hand of the movable base. The amount of movement of the slit is registered by a circular scale round the screw head. When the telescope *T* of the spectroscope is fixed in position on a certain line in the spectrum, the rotation of these screws will bring the slit to different parts of the real image, and will give information as to the occurrence of the element showing that line at any part of the object. If the grating or prism be fixed, the line must stay in position on the cross-wires. In the instrument shown, the spectrum is caused by a reflection grating. To avoid unsteadiness, the telescope of the spectroscope is clamped rigidly in one position, and the grating is rotated to bring different parts of the spectrum into the field of observation. The telescope is an equatorial, and the mechanism for eliminating the effect of the earth's motion is partly shown. With a long train of prisms, as in Mill's spectrograph, where the exposure must necessarily be protracted, the prisms must be protected from changes of temperature, or the deviation will be altered. The camera requires the same sliding base arrangement for the tube carrying its lens, when enlarging the real image. When no enlargement is wanted, the sliding base carries the dark-slide. Such an arrangement needs careful treatment.

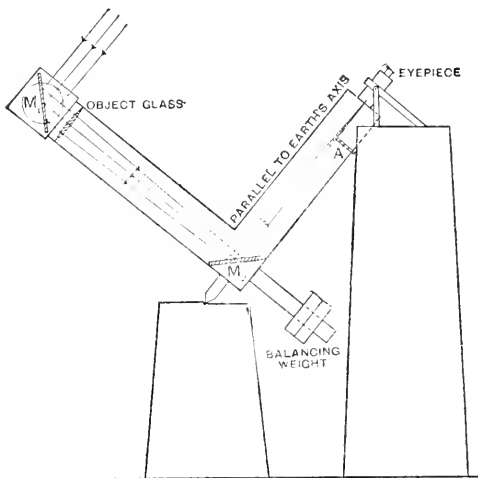

Fig. 805.—THE COUDÉ EQUATORIAL TELESCOPE.

of the chromosphere give the prominences, and show that not only do different prominences vary in chemical constitution, but that the same prominence has different compositions at different levels, because the different rings of colour with their prominences are of different shapes. The spectroscope with its slit is directed close to the edge of the sun's image where the chromosphere is known to be. The method suggested by Sir William Huggins, and applied by Janssen and Lockyer, is used to diffuse the continuous spectrum, and the length of the hydrogen κ line is observed. The length of the slit image will be proportionate to the length of the section across the prominence. By

PHOTOGRAPHING THE MOON.

The moon lends itself to photography most satisfactorily. Its light is simply reflected sunlight, for it has no illumination of its own. The spectrum of moonlight is almost identical with that of sunlight, and the absence of extra absorption lines proves that the moon has either no atmosphere or one of extremely small density. This latter fact explains why such beautifully definite photographs of its surface are obtainable. One great peculiarity of the moon is that it always presents the same side to the earth, and that there is no likelihood of the other side ever being seen. The reason for this is, that the moon itself rotates once in making its revolution round the earth, and the rotation is in the same sense as the revolution. If a person will walk round a table, always keeping his face turned towards it, he will easily grasp the idea of the moon's unique motion. More than just half can, however, be seen. About 59 per cent. of its surface has been photographed. This extra view is due to the varying relative velocity of the moon with regard to the observer.

PHOTOGRAPHIC MAP OF THE MOON.

The latest and most successful photographs of the moon have been taken by Professor Pickering of Harvard. The moon's surface was divided into sixteen parts, and, for convenience of comparison, the sections photographed were somewhat larger than these divisions, in order to allow of overlapping. The moon's surface appears yellow to the eye, and, as a result, the whiter parts are more distinctly shown in the photograph. These white parts have been supposed to be ice. The mountain peaks throw clear-cut shadows, and, by measuring the lengths of these, and calculating the altitude of the sun for that part of the moon's surface, the heights of the peaks may be estimated. The aperture of the object glass used by Pickering was 12 in. in diameter, and the focal length of the telescope was over 135 ft. This extremely long tube with its lens was supported

rigidly, a heliostat mirror being employed to reflect the light into the tube. With such a long focus lens, the real image, without any camera lens to enlarge it, is about 1 ft. in diameter. The mirror of silvered glass was held in a steel fork, and was also independently controlled by electric motors from the eye end of the tube. A rotation similar to that of the mirror was given to the photographic plate. The observatory was situated in the tropics, and therefore the tube of the telescope, which had to be parallel to the earth's axis, was not much out of the horizontal.

THE COUDÉ EQUATORIAL TELESCOPE.

At Paris the instrument used for photographing the moon is the equatorial Coudé (Fig. 808). The telescope tube is in two parts, which are bent at right angles, while at the elbow is a mirror at 45° to the incident light which reflects the rays up to the camera or eyepiece. There is also a mirror outside, which reflects the light into the tube. The object glass is corrected for photographic rays, and has a focal length of about 62 ft. The aperture used is 56 cm. The diameter of the image on the negative, which is afterwards enlarged, is about $6\frac{1}{2}$ in. The most rapid plates are used, and they are exposed for nearly half a second. The telescope is stationary, the plates being moved by clockwork. A fine photograph of the moon, kindly furnished by M. Loewy of the Paris Observatory, and taken by the instrument just described, is reproduced in Plate 41. The parts which come out most distinctly are those which are on the borderland between the dark and the illuminated portions of the moon's surface. When the moon is at its full, the sun is behind the earth, and the lit-up surface is wanting in contrast effects. This corresponds to taking an ordinary view with the sun directly behind the camera. In all cases where the plate is moved to keep the image in position, advantage is taken of the fact that the focal length of a lens is practically the same for all rays which come to a focus on or very near the axis. The

definition of the image, therefore, remains good throughout the exposure. If the axis of the lens be inclined very much to the incident light, a caustic or diffused focus is obtained.

THE PLANETS.

Practically all that has been said with regard to the photography of the moon applies to the planets. These are similar bodies, also revolving round the sun, but are at a greater distance. They simply reflect sunlight, being cold bodies. Their spectra are the same as that of sunlight, with more absorption lines in some cases. Mars has moisture in its atmosphere, and so the absorption bands are more strongly marked in the red. The proof of the rotation of Saturn's rings is mentioned later.

STAR PHOTOGRAPHY.

The stars have been useful from time immemorial in guiding the sailor on the sea, and astronomers are perpetually at work tabulating the positions of the stars for the purposes of navigation. In this department of astronomy alone, photography has worked a complete change. Formerly the measurements had to be made by means of a micrometer movement of cross-wires in the eyepiece of a moving equatorial telescope. Each star's position was fixed by measuring its distances from various well-known stars in its neighbourhood. In another method, the right ascension and declination were noted as the star passed over the cross-wires of the transit instrument. This is a telescope which can only rotate in a vertical plane passing through the south. If the star was missed, it meant waiting a sidereal day before another observation could be made. Now a part of the heavens is photographed to scale, and observations can be made from the plates with ease and certainty without any intermission.

SIZE OF STARS.

The word magnitude, when used by astronomers in speaking of the stars,

simply refers to the brilliancy of these bodies as seen by the eye. The common way of estimating it is by noticing the thickness of a wedge-shaped prism at the place where the light is just extinguished. It would be wrong to take for granted that the size of the image on the plate is an indication of the size of the star. The image of any star (excepting the sun) is a point, because however big the star may be, it is so far away that the rays from any two extreme points of its surface are parallel. This statement must not be confounded with one previously made, that the rays coming from *one* point of the solar surface are practically parallel. The rays coming from two points at the opposite ends of the sun's diameter subtend a measurable angle. In the case of very faint stars, the aid of the camera is invaluable. The eye only perceives the amount of light reaching it at any one instant; the camera, on the other hand, registers the total amount received, and by exposing sufficiently long, a record of this will be plainly visible, even in the case of stars sending forth extremely small quantities of light. The negatives always show many more stars than can be seen by the eye through the same telescope.

STAR SPECTRA.

Without the spectroscope very little advance could have been made in the knowledge of stellar constitutions and motions. As long as sufficient light can be obtained to give a visible spectrum or affect a sensitive plate it does not matter in the slightest degree what the distance of the source is. There are one or two special devices that must be used in obtaining star spectra. The image of a star being a point, the slit method of observation cannot be used. Since the rays from the star are already parallel, the method of the objective prism may be applied. The prism is placed in front of the object glass, which is of long focus, and this gives an extremely narrow spectrum of the usual extent from red to violet. An appreciable width must be obtained before any accurate comparisons can be made. One method is to inter-

pose a cylindrical lens in the path of the light. A point source gives a line image with such a lens. This is a very convenient method for visual observation, and the cylindrical lens may be used for the eyepiece. Another way is to place the refracting edge of the objective prism parallel to the earth's equator. The long thin spectrum will be then at right angles to the apparent movement of the star. If, now, the eliminating mechanism of the telescope be altered slightly in its rate, so as to go a little slow, there will be a trail produced on the negative by each point of colour, and thus the spectrum will be produced with its usual characteristics.

in diameter, on the collimator end. As the platform carries the slit across the image, the effect of a slit shutter is obtained. Light from each part of the image will in turn pass through the slit, and, if a camera be placed behind it, an ordinary negative will be obtained. Instead of that, the light is led through a spectrometer arrangement as shown. The rays coming from the prism are reflected by a mirror into the usual telescope tube, which is furnished with a slit s_2 instead of an eyepiece. The light is brought to a focus by the lens L_2 , forming a spectrum at x , the place of the fixed plate-holder. x is separate from the platform. The ad-

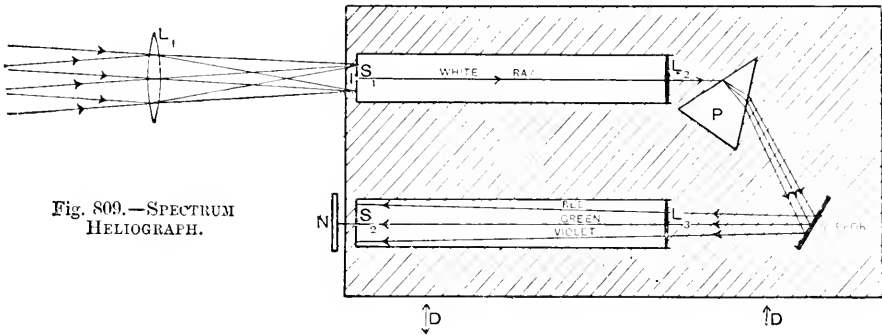

Fig. 809.—SPECTRUM HELIOGRAPH.

There is, however, a difficulty in the objective prism method in keeping the terrestrial spectrum, added for comparison, in the same relative position with regard to the celestial one.

MONOCHROMATIC PHOTOGRAPHS OF THE SUN.

If a source of light be due to the incandescence of various substances, some or all of which are vapours, there will be certain definite lines in the spectrum it produces. If a photograph of the source be taken in one colour, it will evidently reveal the distribution of the substance which produced it. This is done by means of the spectrum heliograph (see Fig. 809). The platform, which is shaded, can move in the direction shown by the arrows D, D . The object glass of a telescope forms a real image of the sun 1, 2 in. or less

justable slit s_2 only allows one colour out of this spectrum to go through, and this repeats an image of that particular component existing in the image at s_1 . Since the deviation of the prism is not altered, the spectrum travels with s_2 . The image at s_1 , on the contrary, is fixed, and does not travel with s_2 . Therefore, as s_1 passes the real image, s_2 repeats the same shape on the plate at x by means of whatever colour s_2 happens to be placed opposite. The collimator, prism, mirror, and telescope tube move bodily with the platform. The light generally chosen is that given by either the calcium or the hydrogen line, as these are very active chemically, and just come within the range of the visible spectrum. In monochromatic photographs, horizontal dark lines may generally be disregarded, since a speck of dust on either of the slits would produce that effect.

SPOT SPECTRA.

The advantage of forming an image on a slit is that the prism analyses the rays coming from a particular portion of the source. If a part of the sun's image with a sun-spot fall on the slit, a dark horizontal band will be seen all across the spectrum. This is a similar effect to that produced by a speck of dust on the slit. A less amount of each colour is presented there, and therefore that part is fainter in all the slit images of the spectrum. Evidently that part must be cooler than the rest of the photosphere. But if the spectrum of the enlarged image of a spot be examined, it is seen not to be a uniform darker band, for certain lines are thickened. This indicates selective absorption, and gives a clue to the substance to be found there. Not all the lines of one element are thickened, and the photographs obtained at maxima and minima of sun-spot disturbance have different lines rendered prominent. At minimum, they are principally lines of well-known elements; at maximum, these are replaced by different lines which cannot be identified. Probably the known elements break up with the increase of temperature.

DISPLACEMENT OF HYDROGEN LINES.

But, very often, the lines of hydrogen will be pronounced, and in agreement with this it has been proved that mighty volumes of hydrogen burst forth, forcing their way into the chromosphere above. It is noticed at such times that the hydrogen lines are displaced towards the violet end of the spectrum. This means that the light due to the hydrogen has become of lesser wave-length. But what can alter the frequency of the received vibration? To explain this, it will be convenient to refer to what is known as Doppler's Principle.

DOPPLER'S PRINCIPLE.

Suppose a source of sound, a whistle for example, is giving out a note of a certain number of vibrations per second. If it be c' the frequency will be about 1,536. The

velocity of this disturbance would be 330 m. per second. It has been proved that sounds of different pitch travel at the same rate. If this whistle be attached to a train travelling at the rate of about a mile a minute or about 37 m. per second towards the listener, the vibration at the end of each second will have 37 m. less distance to travel than the vibrations emitted at the beginning of the same second; and as the velocity of the sound is identical throughout, the vibration emitted last will reach the observer a little earlier than if the train had been still. To the observer, the interval between the reception of these vibrations will be less than a second, or, putting it another way, he will hear more of them per second, and the note will be higher in pitch. The same reasoning will show that if the source of sound be travelling away in the opposite direction with an equal velocity, the frequency of the note will be lower than that emitted by the source by exactly the same interval as it was formerly raised. The frequency will be altered in the ratio of the altered relative velocity of the sound to the unaltered, *i.e.* $\lambda\nu = \lambda_1\nu_1$ where λ stands for the original wave-length, and ν the original velocity of the disturbance. The velocities under different conditions from the two simple cases considered, must not be added arithmetically, but by the Parallelogram of Velocities. In the case where for the instant the source is travelling past the observer at right angles to the direction the sound is taking, his distance from the source remains practically constant over an extremely short period of time, and the note will be unaltered.

APPLICATION TO SPECTROSCOPIC PHENOMENA.

The displacement of the hydrogen line is explained by precisely the same reasoning, only here, much greater velocities are dealt with. Since the intrinsic velocity of light, 186,330 miles per second, is the same for all colours, and the wave-length at the different parts of the spectrum is easily ascertained when using a diffraction grating, Doppler's Principle may be used to

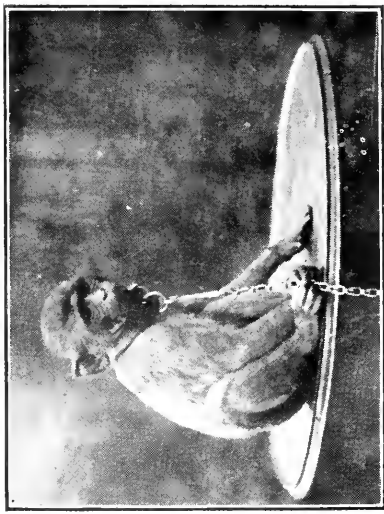
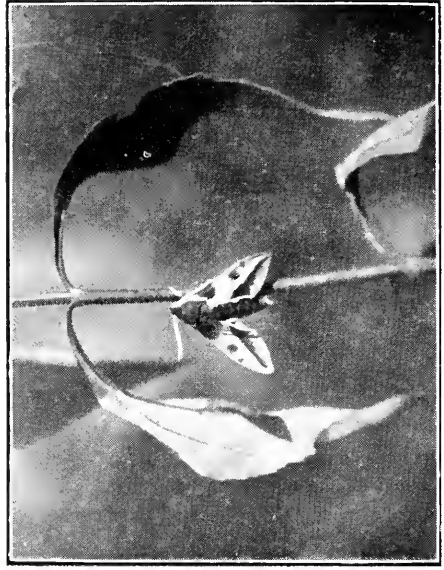

EXAMPLES OF NATURAL HISTORY PHOTOGRAPHY.

calculate the velocity of the moving source of light, which, in the case just mentioned, is a mass of glowing hydrogen. For comparison, just under the spectrum of the solar hydrogen is placed the spectrum of terrestrial hydrogen, heated by an electric spark. The displacement of the solar hydrogen line is measured by means of a micrometer screw, which moves a cross-wire in the eyepiece, or, better still, the two are photographed together, and the displacement is measured at leisure with the help of a vernier-reading microscope. From the displacement, the change of wave-length is calculated; this

at the indicated parts of the spectrum is as follows:—

F line	..	76.66	radial miles per sec.
D	63.42
C	56.78

The velocity obtained is that component which lies in the line of sight. The actual speed may be many times as great, but can never be less (see Fig. 810). The relative velocity obtained must be corrected to find that with which the body is moving in space. Like most astronomical calculations this is very complicated and tedious, and includes allowance for the following velocities:—(i.) The earth's diurnal rotation. (ii.) The earth's revolution about the centre of gravity of the earth and moon. (iii.) The earth's revolution about the sun. (iv.) In the case of bodies which are entirely outside the solar system, the movement of the solar system in space.

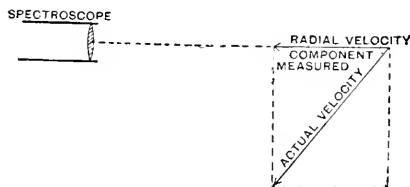

Fig. 810.—DOPPLER'S PRINCIPLE APPLIED TO MEASUREMENT OF VELOCITY.

gives the relative velocity of the travelling light, and the vector difference (obtained by the parallelogram of forces) from the ordinary velocity of light gives the velocity of the hydrogen. As can be seen, the application of Doppler's principle yields a powerful method of research, and makes observations practicable which were once undreamt of. Whenever possible, the comparison is made on the hydrogen line. Sometimes the displaced lines are distorted. If the image on the slit is one of a large mass of gas, whose component parts are moving at very different velocities, each part of the light passing through the slit will produce its image on the spectrum with its own proper displacement. H and K and the other hydrogen lines are generally distorted.

MEASUREMENTS OF VELOCITY.

The length of a light-wave is conveniently expressed in ten-millionths of a millimetre or tenth-metres as they are called. The velocity of the source of light giving a displacement of two tenth-metres

ECLIPSES.

A solar eclipse is caused by the moon coming between the earth and the sun. The moon has an apparent size in the

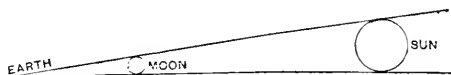

Fig. 811.—SUN AND MOON SUBTENDING EQUAL ANGLES AT THE EARTH.

heavens roughly equal to that of the sun. This is simply due to the relative distances of the two, for the latter is much larger (see Fig. 811). The relative sizes of the two vary somewhat, because the distances of both bodies from the earth are not always the same, since the orbits of the earth and the moon are elliptical. As a result, sometimes the moon completely covers the sun, producing a "total" eclipse, and sometimes leaves a little rim of the sun visible, giving what is termed an "annular" eclipse. The former is the more important, as then a dark shadow of the moon, called an umbra, is cast upon the earth, as shown by Fig. 812. This dark shadow moves across the earth's surface, and takes about a minute and a quarter to transfer its area completely

over any place that lies on the diameter of the shadow. While the sun is thus completely obscured, and all direct rays from the photosphere are consequently cut off, photographs may be taken by ordinary means of the solar surroundings and appendages, which are absolutely invisible under other circumstances owing to the overpowering radiation of the sun.

EXTERNAL AIDS.

Since the light emitted by the gorgeous appearance of the sun's corona, as it is termed, is too faint to be all caught in the small time available for exposure, photographic observations have to be supplemented by drawings obtained by other observers. As the appendages are coloured, the various shades are noted at the same time. It can be well understood

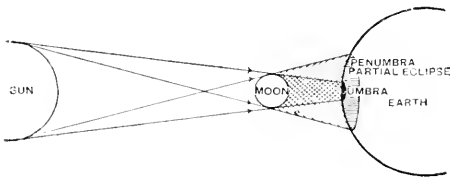

Fig. 812.—UMBRA CAUSED BY SOLAR ECLIPSE.

that careful preparation is needed to get faithful records. Even after much practice, the drawings of the corona at the time of an eclipse vary somewhat seriously, but this difficulty is ingeniously surmounted. Most people have seen composite photographs, produced by superposing six or seven impressions, giving in the finished print a certain type of feature. This method is applied to the drawings obtained at the eclipse, and the composite pictures produced at different observing stations agree very satisfactorily.

INSTRUMENTS USED.

Sir Norman Lockyer, in his eclipse work, lays much stress on the prismatic camera. This is the same as the objective prism apparatus used in studying star spectra. This instrument has two prisms, and the lens possesses the comparatively short focus of 7 ft. 6 in., on account of the

high dispersion given by the two prisms. The deviation of the tube from the original path of the rays is 66° . At the total solar eclipse in 1900, a larger prismatic camera was also tried. The object glass had a focal length of 20 ft. Since the image is formed at the focus, the diverging colours travel three times as far before they unite to form the spectrum. Therefore a single prism with this instrument will give a larger dispersion than two similar prisms with the smaller one, with about half the deviation. Attached to the tubes of these instruments are the finders. The type of photograph obtained has been previously described. A diagrammatic reproduction is given showing how the repetition in colours of the shape of the chromosphere gives a spectrum (see Fig. 807). The prisms used must naturally be very large. The biggest was 9 in. high, with a refracting angle of 45° .

SIDEROSTAT AND CORONAGRAPH.

The siderostat (Fig. 806) has already been described. Besides the larger cameras were some smaller ones provided with transmission gratings to



Fig. 813.—CALCULATING DIAMETER OF REAL IMAGE OF SUN.

show that good work could be done with these. They obtained their light from the spare parts of the siderostats. Three equatorials were included in the outfit for making visual observations. Dark glasses were necessary before and after totality. Two coronagraphs were used for getting ordinary negatives from the corona with which to compare the results from the prismatic camera. These are simply large lenses carried in a tube, which form a real inverted image of the sun at their principal focus, where the sensitive plate is placed. The size of the real image can be easily calculated, knowing the angle subtended by the sun's diameter. (Diameter = [angle in radians]

× focal length.) The largest coronagraph has a focal length of 16 ft. The sun's angular diameter is $32' 4''$, therefore the diameter of the real image in inches = $\frac{32 \cdot 15}{180 \times 60} \times 3 \cdot 14 \times 16 \times 12 = 1 \cdot 8''$. (See Fig. S13.) The only effect of having a larger diameter for the lens is that more light is allowed to pass through.

THE ECLIPSE.

The time of totality is, of course, pretty accurately known, but an image is thrown on a screen by a finder. This enables the observers to place their backs to the sun. Ten minutes before totality, the eclipse clock is set, and stops and caps are taken off. Five minutes before totality, "Ready" is called. Then, at totality, "Go," and everybody begins. The operators and their assistants do their work with the precision of clockwork, the sketching parties are drawing for dear life, the plate holders rapidly move in and out of position as the proper seconds are called out, and in seventy seconds "Over" is called. Thanks to the organisation, everything is a success. Immediately, the work of dismantling begins, and before the next day the chief plates have been developed, and some prints forwarded to head-quarters.

COMETS AND NEBULÆ.

Although Sir William Herschel's telescopes were very large, they were wanting in definition, and it was found difficult to draw the line between star clusters and nebulae. One of the best later instruments is the Crossley reflector at the Lick observatory, which has been chiefly applied to the photography of nebulae. The excellent definition of this telescope has brought to light a more or less evident spiral structure in these somewhat hazy bodies. Nebulae not visible to the eye are rapidly being discovered by photography in every quarter of the sky, and it would seem that they are more numerous where the stars are fewer. For some of them, a ten-minutes' exposure suffices; others need up to three hours or more. Huggins

found that the nebulae gave a bright line spectrum, and that therefore they were gaseous bodies. The number of lines is rarely more than four, and they have not yet been identified. The great nebula of Andromeda is an exception. It has a spectrum that is partly continuous. The spectra of comets vary with nearness to the sun. In the case of one comet, when far away from the sun, λ 5,000 was seen. Then, as it approached, carbon bands were formed; next sodium lines appeared, and finally, iron lines sprang into existence, showing the high temperature finally reached. In taking a photograph of a comet, as it possesses a very large proper motion, the telescope must be kept in position by the observer. As a result, the stars leave trails on the plate parallel to the relative direction in which the comet is travelling.

PHOTOGRAPHY OF LIGHTNING.

Night is the best time to make exposures. The plate used may be a backed one of ordinary speed, and the camera should be pointed in the direction from which the flash is expected. It is better to include a portion of the landscape, or roof tops showing chimney pots, as an indication of the right way up for the picture; or, if preferred, the top of the plate should be marked on placing in or taking out of the slide. The camera should be adjusted to infinity focus during the daytime, unless a focussing scale is provided. A more instructive negative is got by revolving or waving the camera at the time of the flash. If fortunate, the observer will obtain two or more similar impressions, since a lightning flash is of an oscillatory nature, and the electricity passes rapidly backwards and forwards along the path it has forced for itself through the air. The next flash, however, will not traverse the same path, as the breakdown of the air insulation is only temporary. With this plan, however, it must be admitted that there is a decided risk of two different images overlapping and spoiling each other, so that, on the whole, it is better to let the camera remain stationary.

STEREOSCOPIC PHOTOGRAPHY.

PRELIMINARY REMARKS.

It is a wise provision of Nature that her ways need not be understood to be obeyed, so that the man in the street, ignorant of the complex laws his eyes instinctively obey, enjoys without inquiry the benefits of sight. To the would-be stereoscopist a knowledge of such laws is indispensable to ultimate success. Fig. 814 shows a transverse horizontal section of the eye, as it appears when cut

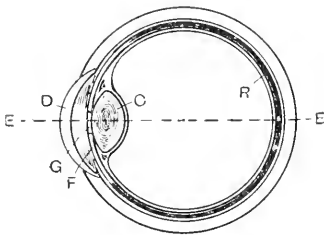

Fig. 814.—TRANSVERSE SECTION OF HUMAN EYE.

through the centre. R is the sensitive membrane, called the retina, upon which images are received of external objects; C is the crystalline lens, the principal refractive medium for gathering light and bringing it to a focus upon the retina; D is the cornea, a supplementary refracting humour, transparent, and bulging forward; F the iris, an adjustable screen, pierced in the centre at G, with an aperture generally known as the pupil. The dotted line at E indicates the axis of the eye, an imaginary line drawn through the centre of the cornea and lens, and extending to the retina. Considering now the process of vision, when an object A (Fig. 815) is looked at, the eye centres itself upon that object, with its axis falling

thereon, the lens C being considerably convex so that its refractive index is suitable for bringing the image of A to a focal point upon the retina at A'. A more distant object, B, which is seen only by oblique rays of light, appears indistinct while the eye is directed to A, because the lens C is of too short a focus for any distance beyond A. In this case B will be brought to a focal point too soon, its clear image being situated within the eye and in front of the retina at B'.

ACCOMMODATION OF THE EYE.

The picture on the retina, under these circumstances, will be composed of a sharp image of the object A, by the side of which will be noticed an indistinct one of the object B. If the observer now desires to look more especially at B, the axis of the eye will turn upon it, as in Fig. 816. Simultaneously with this axial change, the lens C will flatten, or become less convex, so that its focal length is increased, and light from B is brought to a point at B'. The effect of this accommodation from the nearer object A to the more distant object B, will be that A is rendered indistinct upon the retina, its clear image being found to occupy a plane behind the retina at A'. Under these circumstances, the picture upon the retina will be that of a sharp image of B, by the side of which is an indistinct image of A.

FOCAL CHANGES FOR NEAR AND DISTANT OBJECTS.

Thus, in looking to and from the objects A and B, in Figs. 815 and 816, the retinal picture will constantly be subject to transformation as regards definition; each ob-

ject being alternately clear and indistinct, according to the direction of the axis and the focus of the lens. It is this combination of clear and indistinct portions of a composition, together with their constant focal changes, that constitutes the evolutions of sight with one eye. Only two separate and distinct planes have thus far been taken into account, but it is obvious that when a complex subject is under examination, such, for instance, as a landscape, the number of separate planes, or distances, at which objects are situated, may extend to hundreds, each of which will require separate adjustment of the eye in its survey of the whole composition.

AXIAL ADJUSTMENT OF THE EYES.

Passing on to the more complex laws which govern binocular vision, or vision with two eyes, it will be found that, while each eye is subject to the conditions of accommodation above specified, the axial adjustment must work sympathetically. The term "sympathetically" infers, in this case, that when an object is looked at with one eye, the other eye must also be directed thereto; in other words, the axis of each eye must be directed to the object under immediate attention, so that their axes meet at that point or plane. A reflection on what has already been said will show that binocular vision consists in the two eyes having the power to direct their axes to one point, accompanied with the additional power to modulate the refractive humours in such a way that, whatever may be the distance of objects looked at, clear images thereof are projected upon the retina. Thus it is inferred that it is during the actual process of transferring the attention to and from various objects situated at various distances, that the sensation of depth is obtained—a depth, not of tone or of colour, but of solid perspective, otherwise termed stereoscopic.

BINOCULAR VISION.

It has been shown that the images of external objects projected upon the retina in binocular vision are not identical, and

it is this dissimilarity, with the power to combine the dissimilar images in the brain, that gives the observer the idea of depth. Suppose two candles are placed upon a table as indicated in Fig. 817, and the eyes of an observer to be situated at L and R. If the images upon the retina could be examined by a second observer, it would be seen that the picture on the

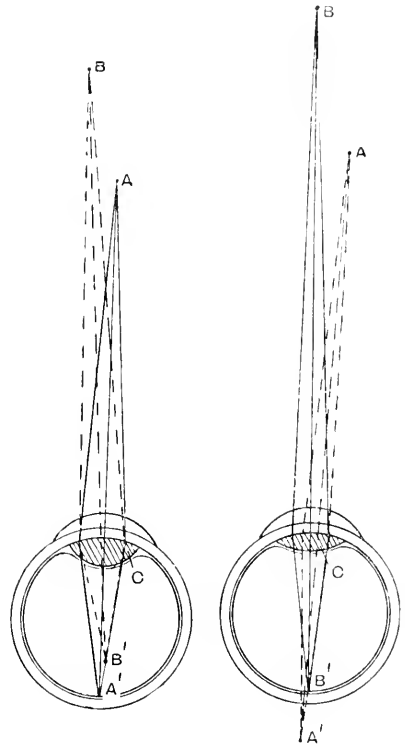

Fig. 815.—ACCOMMODATION OF EYE TO NEAR PLANE.

Fig. 816.—ACCOMMODATION OF EYE TO REMOTE PLANE.

left eye L showed two inverted candles, a short distance apart, while the picture on the right eye R showed two candles also inverted, but one of them slightly hidden behind the other. Now if the two pictures as seen in the two eyes shown in Fig. 817 were coalesced, it would be found that the compound image in the brain was that of two candles, one nearer to the observer's eyes than the other. It is evident, therefore, that by changing the

two eyes L and R for a pair of photographic cameras, two pictures will be obtained corresponding to the two pictures seen by the observer, of the candles placed upon the table. Further, that by combining such photographic pictures in a stereoscope, the original sensation of looking at the objects in Nature will be reproduced.

RELATION OF BINOCULAR VISION TO STEREOSCOPY.

Reference being made to Fig. 818, let the observer's two eyes be represented at

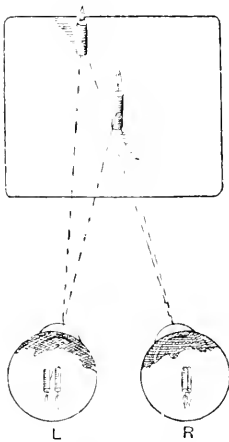

Fig. 817.—THE DISSIMILAR POSITIONS OF THE IMAGE ON THE TWO RETINÆ.

L and R, and an object under immediate attention at A, to which the axes of the eyes are directed. Whilst A is the object of particular attention, the lenses of the eyes, together with their supplementary humours, will be accommodated for distinct vision of A, a picture of which will fall upon the centre of the retina at A' in both eyes, the result being a distinctly projected image of A upon each retina, producing a single impression in the brain, *i.e.* the mind will be conscious of a single object standing before the eyes at A. An object at c, situated in the same plane with A, will also be singly observed, because its image in each eye falls upon c', a point at an equal distance to the left of the axes in both eyes. This

object, however, though seen singly and clearly, is not a predominating object in the mind, because it is only seen obliquely, and light therefrom reaches a part of the retina slightly removed from the centre. With the attention still riveted upon A, an object nearer to the eyes at B will not only be indistinctly seen, because the lenses of the eyes are not accommodated for so near a plane, but its indistinct images upon the retina will not fall on corresponding points; thus, in the left eye it will be on the left of the axis, while in the right eye it will be on the right. It will therefore appear double. Let a finger be held in front of the face, and about twelve inches therefrom, meanwhile looking intently at an object on the other side of the room. While the distant object is perceived as a single one, the finger will appear double. If now, without moving the head, the attention is turned more especially to the finger, the latter, which hitherto appeared double, will now be seen as a single finger, while the distant object first claiming attention is seen double.

DIFFERENCE BETWEEN BINOCULAR VISION AND STEREOSCOPIC PERCEPTION.

From these facts it will be seen that there is one point in which binocular perception differs from stereoscopy, namely, that while in the former changes of focal definition are constantly in operation during the inspection of, say, a landscape, as well as changes of position of objects projected upon the retina, as one and the other are successively observed; in stereoscopy (by which is meant the inspection of a stereograph in a stereoscope) no focal changes are called for, once the correct distance for the photographic print has been found, the analogy of stereoscopy with binocular vision existing only so far as in both cases the axes of the eyes have to undergo a change of direction, as near and more distant objects are successively observed. In other words, with stereoscopy, all objects in Nature, whatsoever their relative distances may be, are reduced to one plane (the surface of the print) with fixed and unalterable focal

values, while in the eye they are reduced to one plane (the retina), but with alterable focal values. In addition to the difference thus indicated between binocular vision and the perception of relief in the stereoscope, there is also the question of magnitude. When a near object is under immediate attention, its magnitude upon the retina is much larger than when the attention is turned more especially to a remote plane.

SENSATION OF RELIEF PRODUCED BY THE STEREOSCOPE.

It is because the two eyes look from slightly different view-points ($2\frac{1}{2}$ in. to $2\frac{3}{4}$ in. apart) that the projected images received upon the retina are not exactly alike. Thus, if two vertical lines be drawn through two corresponding points in the pictures (Plate 39), it will be seen that there is a greater separation between such lines in the right eye picture than in the left eye picture. Owing to this dissimilarity, it is obvious that superimposition of all parts of the two pictures cannot be effected at one and the same adjustment. If the object in the foreground be superimposed, the lamp-post at the remote plane will not coalesce, and there will be a double image. If, on the other hand, the lamp-post is made to overlap, then the figure in the foreground will appear double. But it is not necessary that all parts of the dissimilar pictures should be coalesced at the same moment, for in Nature, as already explained, those parts of a composition which are not for the moment under immediate attention are rendered double, and only become single as the axes of both eyes are centred thereon. In virtue of these facts, and by means of the stereoscope, a dissimilar pair of photographs constitute the means whereby the axes of the eyes are artificially exercised, precisely in the same manner as they would be whilst looking at the objects in Nature; hence arises in the mind of the observer a sensation of relief and solidity, called stereoscopic, which corresponds to the sensation produced in Nature during the inspection of a landscape with the two eyes.

INTERMEDIATE PHASES OF NATURE MISSING IN THE STEREOGRAM.

But while a stereoscopic slide shows extreme phases of binocular vision, and the only two phases depicted on the stereogram, in looking at the original subject there are numberless intermediate phases presented for consideration, making the sensation thus gained far more impressive than the ordinary stereogram can ever do by means of two pictures. How many distinct, intermediate phases occur in the process of binocular observa-

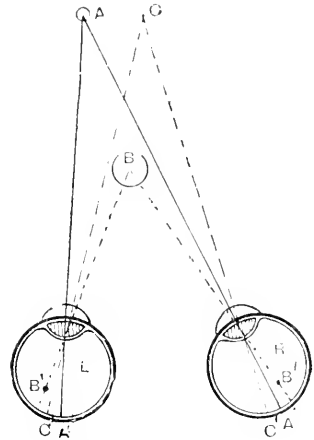

Fig. 518.—THE EYES IN BINOCULAR VISION

tion in Nature it is impossible to say, but certain it is that much of the solidity and beautiful effects noticeable by the careful observer are largely due to the filling in and building up of the subject by the rapid, successive projection of these phases missing in the photographs. It is true that, when examining the stereogram in the stereoscope, the axes change their direction, superimposing all corresponding points in their turn, but this change differs from that of binocular inspection in a manner which will be shown later.

PHOTOGRAPHIC METHODS OF OBTAINING DISSIMILAR PICTURES.

The eye has often been compared with the photographic camera, and, indeed

the analogy is very striking. There is the eyelid or shutter, the iris or stop, the crystalline humour or lens, and the retina or sensitive plate. But the functional analogy existing between the twin-lens camera and the two eyes in binocular vision is still more striking; and if the exact working of the latter were more closely imitated by stereoscopists with their cameras, their work would be far more successful. From a casual observation, it would seem that, to produce a satisfactory stereogram, all that is necessary is to furnish the ordinary camera with duplicate lenses, placed side by side, point them towards the subject and operate in the usual way. But such is not the case

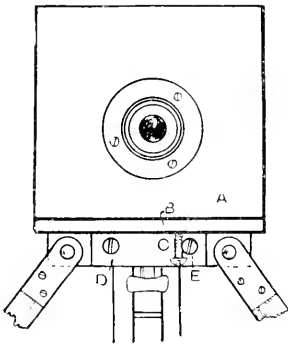

Fig. 819.—ARRANGEMENT OF SCREWS IN BASEBOARD FOR STEREOSCOPY.

If, in ordinary picture-making, each individual subject needs special care and treatment, it is doubly so when stereoscopic work is involved.

CHOICE OF LENSES.

If two lenses are used, it goes without saying that they must be accurately paired, both with regard to focal length and quality. If it is found that one is quicker in its action than the other, which is often the case, this inequality may be remedied by using a larger stop with the slower lens. The angle of the lens employed for stereoscopic work should not be either very wide or very narrow. Wide-angle lenses, usually employed for architectural subjects at close range,

often produce distorted perspective, and exaggerate the magnitude of near objects in comparison with remote ones. Narrow-angle lenses, on the other hand, have a tendency to reduce the stereoscopic effect, since near objects cannot be embraced. It is therefore best to choose a lens with a moderate angle, and with a focal length of, say, about five inches. For landscape work, a deep focus will be required, but in some cases shallow focus lenses give pleasing results, especially when it is desirable to give prominence to any particular object. So far as the character of the lenses is concerned, it is only necessary to say that the lens which will give the best single picture, free from optical defects, is the one desirable for stereoscopic work. Beginners, however, may obtain quite excellent results with inexpensive lenses, for it is a point in favour of stereoscopic work, that many a picture lacking in interest as a mere photograph possesses a charm when viewed stereoscopically.

STEREOSCOPY WITH ONE LENS, TWO EXPOSURES.

Although accompanied with certain disadvantages, there are many ways of taking the dissimilar pair of pictures with an ordinary camera having only one lens. If a half-plate camera is used, the lens may be mounted on a front panel sliding horizontally from one side to the other between the two exposures; in this case a partition in the camera will be needed. Another method is shown in Fig. 819 with a resulting picture (Plate 39). The half-plate camera A, as shown in Fig. 819, is attached to the tripod head in the usual manner by a T-screw. Two ordinary screws D and E are fixed horizontally to the side of the tripod head, while a third screw C is attached to the underside of the camera baseboard B. These screws are inserted in such a position that when the camera is turned to the right or left, as the case may be, the screw C comes into contact with D or E at right angles. To find out the exact position on the baseboard where the second horizontal screw D should be fixed, the image on the first

half of the screen with the camera in the first position (with the screws *c* and *E* touching) is noted, and the camera turned till the image occupies exactly the same position as before, but on the second half of the screen. The screw *c* is then inserted in the baseboard touching the screw *D*, when the movement of the camera will be limited to the space between the two screws *E* and *D*.

METHOD OF AVOIDING TRANSPOSITION.

To take the double view so that no transposition of the prints will be necessary, and also that only one half is taken on the plate at each exposure, an ordinary half-plate is cut in two, and one half made opaque by exposure to light and development. This opaque glass is placed in the dark slide in front of the plate to be exposed, covering up exactly one half of it. The camera is now turned till the vertical screw touches one of the horizontal screws. The view is focussed and kept well within the limits of the half of the screen that is diagonally opposite the subject. Thus, if the camera is pointed to the left, as in the illustration, with the screw *c* in contact with the screw *E*, the subject will be focussed on the right of the screen. The dark-slide is now inserted in the camera in the usual manner, the shutter drawn out, and the exposure made. One half of the plate having been exposed, the dark-slide is closed and taken from the camera. It is then shaken so that the opaque glass is made to cover up that portion of the plate just exposed, and to uncover the unexposed portion. The camera is next turned so that the screw *c* touches the horizontal screw *D*; the dark-slide is inserted as before, and the second exposure made, when the second half of the plate will receive the second image of the stereoscopic pair.

USE OF SLOTTED BOARD WITH SINGLE LENS.

The usual quarter-plate size camera is very suitable for stereoscopic work when successive exposures are made, and it has been said that a quarter-plate hand

camera in which one exposure is made in a set position, and a second after moving a few inches to the right or left, furnishes excellent stereoscopic views; but it is evident that this practice possesses also a certain element of uncertainty. It is therefore better to adopt one of the following methods. Reference being made to Fig. 820, a board having a slot at *D*, through which the T-screw of the camera is passed, is thus secured to the tripod head in the usual manner. With the camera in the position indicated by the dotted lines *c*, the first plate is exposed. The board carrying the camera is then

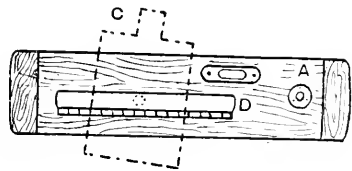

Fig. 820.—SLOTTED BOARD FOR ONE-LENS STEREOSCOPY.

turned 180° on *A* (which is the point at which it is attached to the tripod). The camera is now turned on its own axis and directed again to the object to be photographed, when the second plate is exposed. By means of a scale marked along the edge of the slot *D* the proper convergence

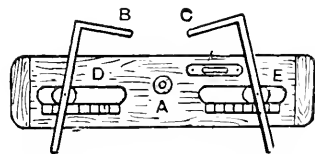

Fig. 821.—DOUBLE SLOTTED BOARD.

of the lens is found, thus dispensing with the need to examine the screen of the camera between the exposure of the first and second plate.

OTHER METHODS AVAILABLE FOR ONE-LENS WORK.

A very similar apparatus is that illustrated in Fig. 821. In this case the board is not moved between the exposures, but, instead, the camera is removed from the

slot D to the slot E, the board itself being attached to the tripod at A. At B and C detachable squares are provided, whereby the proper position of the camera for each picture may be determined. A still simpler form of stereoscopic head is shown in Fig. 822. The camera is attached either at B or C and removed between the two exposures to the opposite end. This method does not provide for variation



Fig. 822.—STEREOSCOPIC TRIPOD HEAD FOR ONE-LENS WORK.

of distance between the two points from which the stereoscopic pictures are taken. An apparatus, termed the "Stereoscopic Tray," is shown in Fig. 823, and is intended to be used for stereoscopic work when a hand camera is employed. The camera, indicated by the dotted lines, is placed at one end of the tray. An exposure is then made, and the camera removed to the opposite end for the second exposure. The distance between C, c, being somewhat less than the distance between B, B, the axis of the camera in the two separate positions is such that

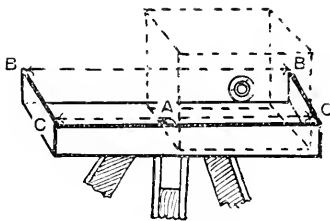

Fig. 823.—THE STEREOSCOPIC TRAY.

the lens is made to cover the same field of view in both positions.

THE STEREOSCOPIC ADAPTER.

Fig. 824 is an improvement on the apparatus already mentioned, inasmuch as the work of accurately shifting the camera between the two exposures is done with

the least possible loss of time. The camera is fixed at the block B, with the lens pointing over A. One exposure having been made, B, carrying the camera with it, is moved in the direction of the arrow C till the two blocks are again touching each other, when the second plate is exposed. It will be seen that the parallel movement is regulated by a pair of metal links communicating with the two blocks. F is the screw and nut by which the apparatus is connected to the tripod head. An apparatus similar to the above, but with the addition of adjustable means for the separation of the two view points, is shown by Fig. 825. Two blocks, C, B, are connected together by four parallel links. Two of these links are seen at E, F. A scale is provided at J, which has a projection at right angles, upon which rests the adjustable screw G.

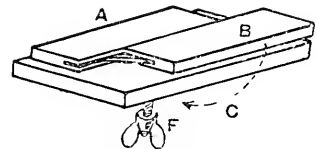

Fig. 824.—THE STEREOSCOPIC ADAPTER.

It is obvious that, by turning the screw in or out, as the case may require, the play of the carrying block B will be diminished or increased. The camera employed is attached to the block B, one exposure being made with it in the two positions D and A.

STEREOSCOPIC EFFECTS BY MOVING THE SUBJECT.

When the subject is small, such, for instance, as a vase of flowers, very good results may be obtained by displacing the subject between the exposures of the two plates; but in this case an absolutely plain background must be provided, and the subject must not be too highly lighted, otherwise the dark shadows cast, which are not stereoscopic, will produce unsatisfactory results in the combined view. In microscopic work, the subject should be mounted on a tilting slab.

BROWN'S STEREOSCOPIC ADAPTER.

Before leaving the subject of successive exposures, reference should be made to the device originated by Theodore Brown, of Salisbury. Fig. 826 will explain this system, which is intended especially for hand cameras that may be used on a tripod. The hand camera indicated at A, with its lens at B, is supplemented with a chamber J, containing three plane mirrors E, F, and G. The mirrors E and F are hinged towards the front of the

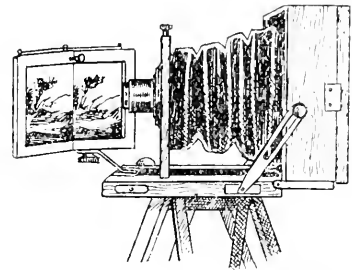

Fig. 827.—THEODORE BROWN'S STEREOSCOPIC TRANSMITTER.

that this system is very near to that of simultaneous exposures, which will now be considered.

STEREOSCOPY WITH ONE LENS, ONE EXPOSURE.

The inventor of the last mentioned device was also the originator of the instrument termed the "Stereoscopic

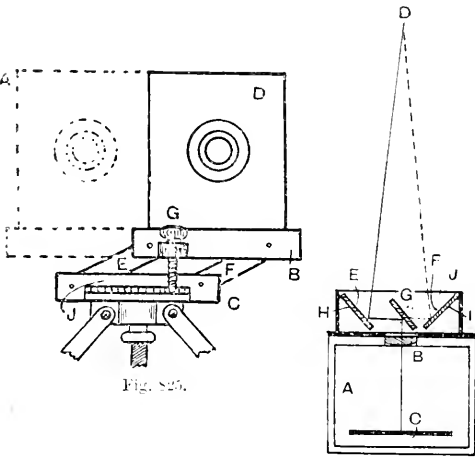

Fig. 825.—ADAPTER WITH ADJUSTABLE SEPARATION.
Fig. 826.—THEODORE BROWN'S REFLECTING ADAPTER.

chamber, and their angles may be varied by means of screw rods at H and I. The central mirror G is silvered on both sides, and turns on vertical centre pivots. Supposing the subject to be photographed is situated at D, one exposure is made, when the course of the light will be D to E, E to G, and G to the plate c. The first plate thus exposed, the central mirror G takes a quarter turn, so that, when the second exposure is made, the light received by G comes from an opposite point F, and is deflected to the plate c as before. If the subject stands at a greater or lesser distance than D from the camera, the mirrors E and F are adjusted accordingly, so that the image emanating either from E or F falls upon the centre of the plate c.

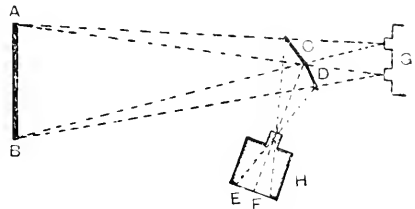

Fig. 828.—PRINCIPLE OF STEREOSCOPIC TRANSMITTER.

Transmitter," shown in the accompanying illustration, Fig. 827. Here the principle of reflection is used in the following manner, reference being made to Fig. 828. Let an ordinary camera with only one lens be represented at B, the transmitter at C D, and the subject to be photographed at A B. In virtue of the fact that the angle of reflection is equal to the angle of incidence, light emanating from A B will be reflected by the mirror C,

through the lens to the portion of the plate *F*, whilst light coming from the same source *A B* and received on the mirror *D* will be reflected through the lens to the portion of the plate at *E*. A person standing at *A B*, and looking towards *c* and *D*, would see a double reflection of the single camera *H* at *G*, the latter representing, and, indeed, acting the part of, a twin lens camera. Hence the subject being reflected from two separate view points, *i.e.* *c* and *D*, dissimilar images will be received upon the two halves of the plate *E* and *F* in the camera *H*, such images being stereoscopic phases. A

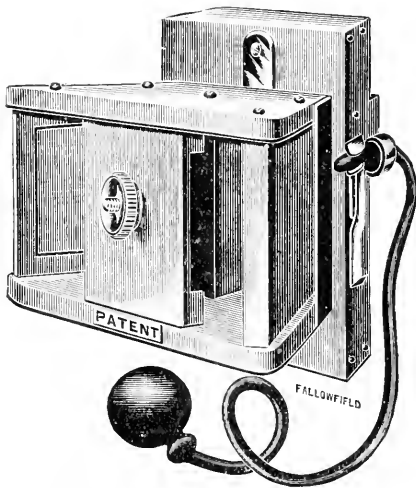

Fig. 829.—THEODORE BROWN'S STEREO-PHOTO-DUPLICATION.

point in favour of this system is that, during the process of reflection, the light from the separate view points is made to cross before reaching the sensitive plate, so that transposition of the images takes place irrespective of inversion—a fact which enables prints to be made direct from the negative so obtained, when they will be found in their proper order for immediate mounting and inspection in the stereoscope. Against this advantage, however, must be set the fact that as the dissimilar images are reflected, they become reversed as regards right and left, an error which may easily be corrected by the carbon or other similar process if

it is imperative that the subject should be correctly shown in this respect. It is also suggested that when using films they may be inserted in the camera, celluloid surface uppermost, so that the picture reaches the sensitive film after passing through the celluloid, a process that would correct inversion in the printing stage.

THE STEREO-PHOTODUPLICATION.

Yet another device by the same inventor is that shown in Fig. 829. Here again the principle of reflection is used, but in this instance four mirrors are employed instead of only two, as in the former instrument. The working of this apparatus, called the Stereo-Photoduplicon, will be understood by reference to the diagram Fig. 830. Suppose the subject to be situated at *E E*, the camera at *D*, and the lens at *c*. By means of reflection two views of the subject are carried to the plate in the camera thus, by reflection from the mirrors *A A* to *B B*, and thence through the lens to the plate. There are various other devices in which, by means of reflection, two dissimilar pictures are obtained for stereoscopic purposes. These consist of different arrangements of mirrors and prisms, or of prisms alone.

THE STEREOSCOPIC CAMERA.

Particulars have already been given as to the general nature of the stereoscopic camera proper in an earlier part of this book; it now remains to point out some of the essentials for practical work, and how the best results are to be obtained. The simplest form of stereoscopic camera consists of a partitioned box, with a pair of lenses mounted on its front in a fixed position. It is easy to see that such an apparatus cannot fulfil all the requirements of stereoscopic work, for according to the distance of the nearest object in a composition, so must be the separation of the lenses, or their convergence.

ADJUSTMENT OF VIEW POINTS.

Reference being made to Fig. 831, when the eyes of a person are directed to a

remote distance, their axes run almost parallel, as at B and C, in which case the pupillary centres will be $2\frac{1}{2}$ in. apart. Immediately on turning the attention to a near object, such as A, the eyes turn in their sockets, when the pupillary centres will be reduced to $2\frac{3}{8}$ in. apart. From this it will be seen that, in binocular vision, the object looked at occupies a central position on the retina of each eye, and that precisely the same field of view is covered by both eyes along the plane at which the object of immediate attention is situated. This seems to suggest that the

first place, by having a suitable tripod head, as in Fig. 832 at c, the separation of the view points may be extended to many inches or reduced to the normal, by displacement of the supplementary camera D along the slot A. The axes of the cameras may be made to meet at any specified distance, and the sensitive plate may be kept at right angles to the axes of the lens, whatever may be the position of the camera. The value of these three points will be appreciated by the worker who is called upon to do every class and

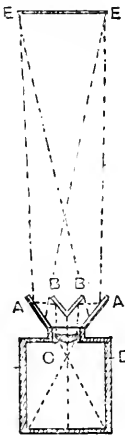

Fig. 830.

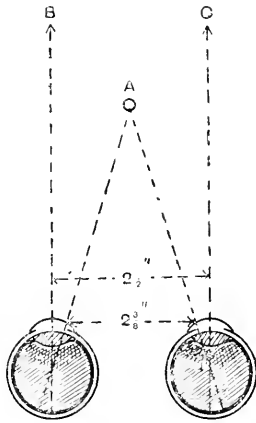

Fig. 831.

Fig. 830.—PRINCIPLE OF STEREO-PHOTODUPLICATION.
Fig. 831.—DIFFERENCE BETWEEN DISTANT AND NEAR VISION.

adjustment for stereoscopic view points in a camera should not be effected by merely moving the lenses in a parallel direction towards each other (as generally advocated), but that either the lenses themselves should be made to converge or diverge upon their separate axes, or the stereoscopic apparatus should be composed of separate cameras capable of being turned on independent axes.

DUPLICATE CAMERAS FOR STEREOSCOPIC WORK.

There are many things to be said in favour of duplicate and independent cameras for stereoscopic work. In the

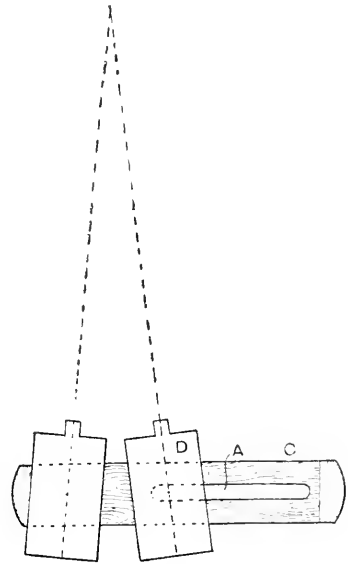

Fig. 832.—STEREOSCOPIC WORK WITH DUPLICATE CAMERAS.

variety of work. The vexed question as to what should constitute a proper separation for lenses in stereoscopic photography may be answered in a few words, and efficiently provided for in apparatus such as indicated in Fig. 832. The separation must be varied according to the nature of the subject in hand and the requirements of each individual case. In subjects where the foremost object stands about five feet distant from the camera, a separation of two and three-quarter inches will be sufficient. In one where the nearest object is fifty feet distant, then the separation of the lenses may be increased to six or

seven inches, while with a subject in which there are no objects within five hundred feet, a separation of twelve feet between the two view points may be made. It should be mentioned, however, that when stereoscopic effects are desired of very distant subjects, the relief obtained by taking the two pictures from view points that are widely separated tends to give a model-like appearance in the stereoscope, rather than a truthful binocular impression.

TREATMENT OF FLORAL SUBJECTS.

There is, perhaps, no subject that lends itself more effectively to stereoscopic

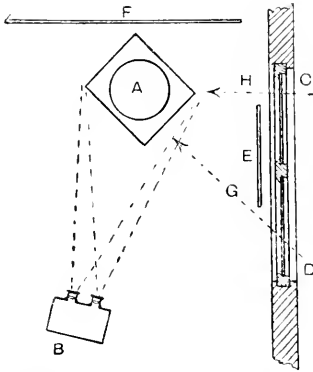

Fig. 833.—METHOD OF LIGHTING FLORAL STUDIES.

treatment than flowers. When the blossoms are of a light tone, such as white, correct lighting is a point that must have careful attention. Unless the light is properly controlled, flowers, especially white ones, will often give disappointing chalky results, in which all the delicate details are lost. An example of a properly lighted subject is shown in Plate 40. In this case a semi-transparent appearance has been given to the petals of the flowers, which has a very pleasing and natural effect. It will be remarked that even as a monocular or single photograph, a considerable degree of roundness has been secured, which adds substantially to the effect when the picture is supplemented with its companion and studied in the stereoscope. To render floral subjects in this pleasing

manner, the lighting is arranged as follows:—The subject, represented at A (Fig. 833), is placed in front of an opaque background F. The light from the large side window, situated at C D, is partly intercepted by a semi-transparent blind E. Hence, while a strong light strikes the subject in the direction of the arrow G, a supplementary and weaker back light falls upon it in the direction of the arrow H. The camera, it will be seen, is situated at B. When taking this picture, the nearest object (the middle spray of flowers) was only six feet distant from the camera, so that the separation of the lenses had to be reduced to two and a half inches and their axes made to meet in the centre of the flower-pot.

GOOD COMPOSITION, BAD LIGHTING.

In Plate 40 a well-arranged subject has been shown, which, however, is disappointing owing to the chalky effect referred to in the last paragraph, and to the absence of intermediate tones. This subject, taken from precisely the same view points, would have made a charming picture had it been photographed in a subdued light, rather than illuminated in the glaring noonday sun. As a general rule, the most satisfactory pictures for the stereoscope are those that have been taken slowly in a dull light, and it may be mentioned here that single prints which are objectionably flat owing to over-exposure become the direct reverse when treated stereoscopically. Stereoscropy offers a wide choice of subjects—wider, in fact, than ordinary single lens photography. It is unnecessary, perhaps, to offer any further remarks on this point, except to comment on the singular beauty of stereoscopic night effects, two admirable examples of which, by Mr. F. G. Tryhorn, are given in Plate 28.

DEVELOPMENT OF THE STEREOSCOPIC NEGATIVE.

The development of stereoscopic plates being similar in treatment to any ordinary dry plate, it is only necessary to say that uniformity, when two separate plates are

in use, should be aimed at. Over-development is to be preferred to under-development. A thin negative yields far better prints for stereoscopic pictures than a dense one. A special point to be remembered in the development of stereoscopic negatives is to obtain as much detail as possible in the darker portions of the pictures before the high lights have become too dense. To ensure this, a formula containing very little pyrogallic acid should be used: failing this, eikonogen, amidol, or metol will be found to give satisfactory results.

RETOUCHING STEREOSCOPIC NEGATIVES.

It is next to impossible to retouch two negatives forming a stereoscopic pair with absolute equality, and, unless every touch applied to the left negative is accurately duplicated in the right negative, the effect in the stereoscope when the resulting prints are combined will be anything but satisfactory. White spots, resulting from the retouched negatives, will appear as floating specks of dust in mid-air. For this reason it is advisable to omit retouching altogether, with the exception of blemishes that may occur in the darker portions of the composition, which may be dismissed by careful treatment. The best method of doing this is to spot the prints after they are mounted. Any of the commercial "printing-out papers" are suitable for stereoscopic pictures, also enamel surface bromide paper, which will prove useful if circumstances prevent the use of daylight for printing. A dark print is preferable to a weak one, as the stereoscope enables the eyes to pick out details even in the shadows which would be overlooked in a single print of equal depth unassisted by glasses.

TRANSPPOSITION OF THE PRINTS

When the dissimilar negatives have been secured on two separate plates, it is only necessary to see that the picture obtained from the right-hand view point is mounted on the right-hand end of the card or mount, and the picture obtained from the left-hand view point mounted on the left-

hand end of the card. If, however, the stereoscopic pictures are secured on a single plate side by side, in a binocular camera, then transposition will have to take place. Either the double negative must be cut asunder and remounted upon a clear sheet of glass with the two negatives changed over, or the prints must be treated in a similar manner before they are mounted upon the card. When a very large number of prints are likely to be wanted of any one picture, it is best to cut the negative and remount as indicated, before commencing to print therefrom, but when a few prints only are required, it is better to cut the prints.

TRIMMING THE PRINTS.

In the trimming of stereoscopic pictures there are two points to be determined, namely, the size of print and position of cutting gauge upon the picture. The width of the dissimilar pictures being determined by the normal separation of the eyes, $2\frac{1}{2}$ in., it only remains to decide on their height. Most stereoscopic mounts are now supplied to take pictures not exceeding $3\frac{1}{2}$ in. in height. A very suitable size for the prints is $3\frac{1}{4}$ in. by $2\frac{1}{2}$ in., and a glass cutting shape of this size should be provided. It will be useful to have etched upon the under surface of the glass a vertical and a horizontal line exactly crossing in the centre. These lines may be made by scratching with a diamond or glass cutter. They will enable the glass to be readily placed in position at the time of trimming the prints.

POSITION OF CUTTING SHAPE.

The prints to be trimmed should be placed face upwards upon a large sheet of glass, preferably plate, and the glass gauge laid upon the print with the etched lines in contact with the latter. The vertical line on the glass should be parallel to vertical lines in the picture, such, for instance, as the side of a building, while the horizontal line should be made to intersect corresponding points in both pictures. Unless this is done, the dissimilar images will be on different planes or out

of level with each other, an error that will render it difficult to combine the two pictures when they are inspected in the stereoscope. The amount of subject included in each of the dissimilar prints will, of course, be equal, but owing to their dissimilarity certain differences will arise as to objects included. When the subject is examined in the stereoscope it should

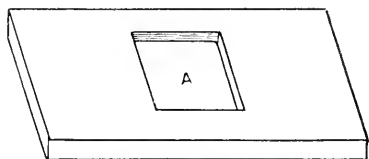

Fig. 834.—FRONT OF SIMPLE TRANSPARENCY PRINTING FRAME.

present the appearance of relief with all the composition lying beyond the margin of the print. To obtain this effect, a little more of the subject should be left on the left-hand edge of the right picture, and a little more on the right-hand edge of the left picture.

MASKING.

By the term masking is meant the taking of a print from a negative through an opaque mask, with openings shaped according to fancy and suitability to the subject in hand. This opaque medium,

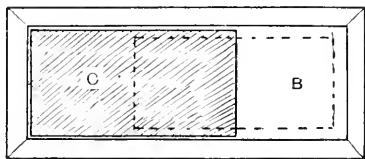

Fig. 835.—FIRST POSITION OF NEGATIVE AND PLATE IN FRAME.

termed a mask, is generally inserted between the film of the negative and the front side of the paper or sensitised surface upon which the positive is to be received. The dimensions of the openings must be within the limits already stated for trimming prints. It will sometimes be necessary to reduce the width of the two parts forming the stereoscopic negative. This should be done at the stage of

cutting the negative apart for the purpose of transposition. Whatever may be the shape of the mask adopted, it is better that the openings should be rather under than over $2\frac{3}{4}$ in. in width. If over this size, the distance between corresponding points in the dissimilar pictures will be too great for easy combination in the stereoscope, especially when the latter is without means of varying the refracting angle.

MOUNTING STEREOSCOPIC PRINTS.

When the prints have been taken after transposition of the negatives, the binocular pictures will, of course, be on one



Fig. 836.—BACK OF TRANSPARENCY PRINTING FRAME.

piece of paper and in their proper order for pasting upon the card. When, however, they have not been treated in this manner, care will have to be exercised in seeing that the right-hand picture is placed on the right-hand end of the stereoscopic mount, and the left-hand picture on the left-hand end of the mount. Failing this, what is known as a "pseudoscopic" effect will be produced when the pictures are examined in the stereoscope. *i.e.* objects in the composition that should occupy a remote distance appear in the foreground, while objects that should stand in the foreground recede. Under these conditions, concave becomes convex, and *vice versa*. To prevent error in mounting, it is therefore necessary to mark the pair of prints in some way. This should be done before the double photograph is separated. Place it on the table face uppermost, with the subject erect, and then turn it over without inverting it. On the left-hand end and back of the print mark L, and on the right-hand end mark R. They may now be numbered in pairs and cut apart, when it will only be necessary to refer to the letters on the back when mounting.

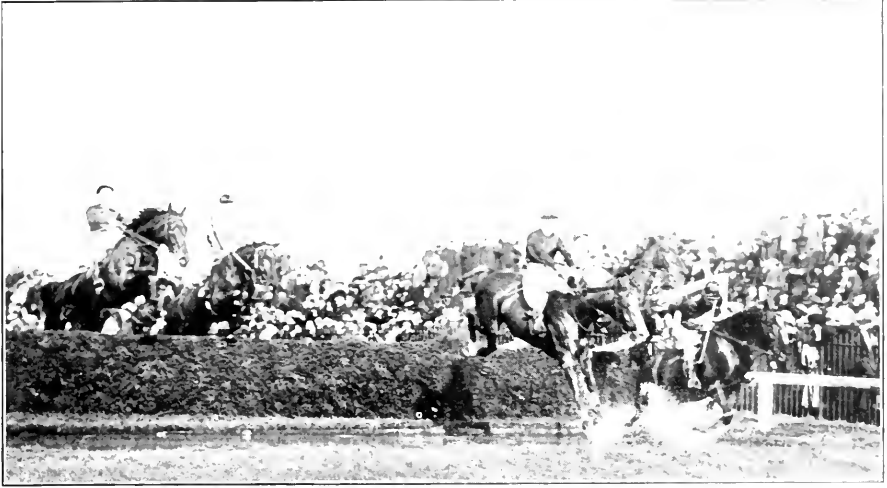

Negatives by Bowden Bros., 196, Buckingham Palace Road, S.W. Taken with Voigtlander's Collinear Lens. Series 1.

EXAMPLES OF INSTANTANEOUS PHOTOGRAPHY.

MAKING TRANSPARENCIES.

It has often been said that photography attains its highest perfection and beauty in a good transparency, and this statement is not without foundation, especially when the transparency is a stereoscopic one. There are two ways of making a transparency. One is by contact printing, and the other by copying in a camera. The latter method is, perhaps, productive of better results, but by adopting the former there is the advantage of simplicity, no special apparatus beyond a printing frame being necessary. The frame shown by Fig. 834 is somewhat different from the ordinary style. It has an opening A one-third of the entire width of the recess or rebate, in which the negative is placed. Fig. 835 shows one position of the negative and positive plates when inserted into the rebate, and before the back (Fig. 836) has been placed in position. This pattern printing frame is intended for use when a positive is to be made from a stereoscopic negative in which the two images have not been transposed. In order, therefore, that the positive images shall be taken direct on one plate, and in their proper order for the stereoscope, the negative is placed with its edge in contact with one end of the rebate, while the sensitive plate on which the positive is to be printed is placed with its edge in contact with the opposite end. They will thus overlap each other just opposite the opening A (Fig. 834). The back of the frame is then inserted and the exposure to artificial light made. This done, the negative and positive are made to change positions, as indicated by Fig. 837, when the second half is exposed as before. Needless to say, the negative is placed in the frame first, with its film side uppermost, the positive plate being laid on top, with its film side in contact with the negative.

RICE'S STEREOSCOPIC PRINTING FRAME.

Another and more elaborate pattern printing frame, in which transposition may be effected at the time of making the transparency, is shown by Fig. 838.

This is made by Watson and Sons, and was invented by Mr. W. Rice. Its chief improvement on the simpler pattern already described consists in the means it provides for precise levelling. If, for instance, the dissimilar images on the stereoscopic negative do not happen to be exactly on a level, or in exactly the

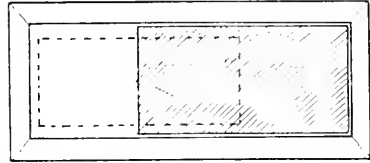

Fig. 837.—SECOND POSITION OF NEGATIVE AND PLATE.

same plane, levelling may be done at the stage of taking the print, the transparency plate being carried in a supplementary and inner frame. This inner frame is held in any desired position by means of thumbscrews extending through the outer frame, as shown. Any selected part of a negative can be accurately centred, and non-horizontal pictures corrected, in the manner described. When

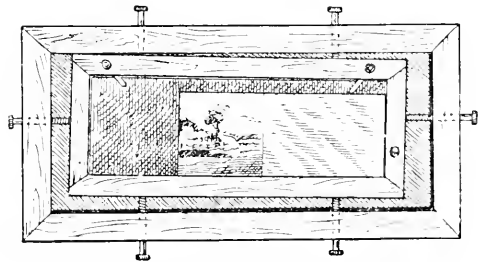

Fig. 838.—THE "UNIVERSAL" STEREOSCOPIC TRANSPOSER.

transparencies are needed from negatives obtained by means of the "Stereoscopic Transmitter" or "Stereo-Photoduplicon" (see Figs. 827 and 829) an ordinary half-plate printing frame is all that is needed, since no transposition is required.

TRANSPARENCIES IN THE CAMERA.

The second method of making stereoscopic transparencies is by copying the

negative, using the positive plate in the camera, as shown in Fig. 839. For this purpose the twin lens camera used in the production of the original negative may be employed, or, at any rate, the same lenses may be used. A table with a slot at A is provided, to which a box camera B may be attached. A second box C is furnished for the reception of the stereoscopic negative at D, a partition is inserted at E, and the inner sides of the negative box blackened. The lenses of the copying camera at F G should be adjustable as regards their separation. The sensitive plate is situated at H H, and exposed in the usual manner, the negative at D being illuminated by transmitted and diffused light. In the development of transparencies, softness and

binding lantern slides, described in another section of this book. It is advisable, however, in most cases, to use a semi-transparent glass for backing up the picture, so that the light is nicely diffused before passing through the positive to the eyes of the observer. Such semi-transparent glasses being a commercial article, the worker will have no difficulty in obtaining what is wanted. Masks may be introduced between the positive film and the cover glass, but the shape of the openings should be chosen with due respect to the nature of the subject in hand, and, as already stated, the diameter of each opening should not exceed $\frac{3}{4}$ in. in width.

VIEWING DEVICES.

It has already been shown that the natural tendency of the human eyes is to turn their axes to one point. This fact necessarily constituted the first difficulty experimenters had to face in their endeavours to present to each eye a separate view of the same object as seen in binocular vision. Mr. Elliott, in the year 1834, was the first to conceive an instrument, shown by Fig. 840, for the purpose of aiding the eyes to see pictures placed side by side, although he did not construct his apparatus till the year 1839. A box D, pierced with three holes, E, F, and G, enables the observer who places his eyes at L and R to cross their axes. The pair of dissimilar pictures are placed at A and B, A being seen by the right eye, while B is seen by the left. No lenses are used in this instrument, and it is obvious that some little practice is required before satisfactory results are obtained. Nevertheless, this apparatus, crude as it may seem, is extremely interesting, marking as it does the beginning of a science which has been, and still continues to be, both fascinating and of importance.

THE WHEATSTONE STEREOSCOPE.

Professor Wheatstone, however, was the first to construct a really practical apparatus for viewing stereoscopic pictures; this he exhibited before the British

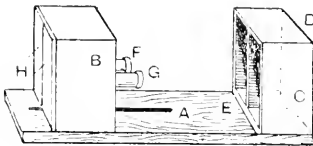

Fig. 839.

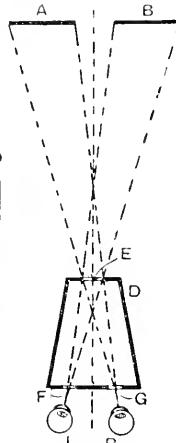

Fig. 840.

Fig. 839.—MAKING TRANSPARENCIES IN THE CAMERA.
Fig. 840.—PRINCIPLE OF ELLIOTT'S STEREOSCOPE.

detail in the shadows should be aimed at. Density can be carried to a greater extent with transparencies than with paper prints, since the means of their examination (transmitted light) is powerful as compared with the weaker or smaller quantity of light that is reflected from a paper print.

BINDING TRANSPARENCIES.

The binding-up of stereoscopic transparencies is a process similar to that of

Association at Newcastle in August, 1838, where he delivered an important paper on the "Physiology of Vision." Fig. 811 shows the Wheatstone Stereoscope. The eyes of the observer looking through the holes at C and D see in mirrors at E and F reflections of the two dissimilar pictures placed in the holders at A and B. H is a screw rod running the entire width of the instrument, and operated by means of the handle at G. The thread on the screw rod, being reversed at opposite ends, engages with plates at the foot of the two holders A and B, so that the position of the pictures is changed simultaneously as they are made to recede or approach the mirrors. It is evident that when the Wheatstone Reflecting Stereoscope is used the pictures will be reversed, so that in subjects where tools

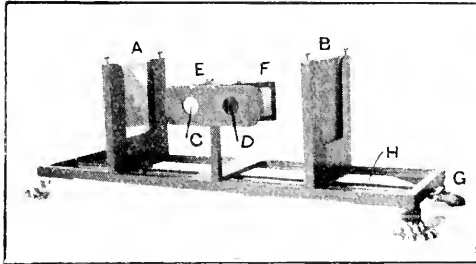

Fig. 811.—THE WHEATSTONE STEREOSCOPE.

are being used the workmen will all appear to be left-handed. Lettering on a sign will read backwards, or the right-hand side of a street will become the left in the view. Of course, this error may be corrected in the print if desirable, and, in the case of transparencies, they may be placed in a reversed position in the holders. Apart from these drawbacks of the Wheatstone Stereoscope, there are others, namely, its non-portability, and, worse still, unless special mirrors, silvered and burnished on the face, are used, the pictures will not be seen perfectly defined, there being a double reflection of each picture, one image coming from the metallic surface and a fainter image from the surface of the glass. With all its defects, however, this instrument marked a notable advance in viewing devices.

BREWSTER'S STEREOSCOPE.

Sir David Brewster, observing many imperfections in the reflecting type of stereoscope, turned his attention to the subject, and presently brought forward his great improvement, the lenticular stereoscope, which is shown by Fig. 812. Brewster conceived the idea that if the principle of refraction was employed instead of reflection, the apparent displacement of the dissimilar pictures could be effected without loss of light or definition, and with the additional improvement of magnification. The principle of this instrument will be understood by Fig. 813.

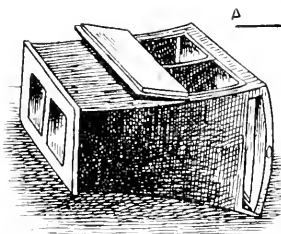

Fig. 812.

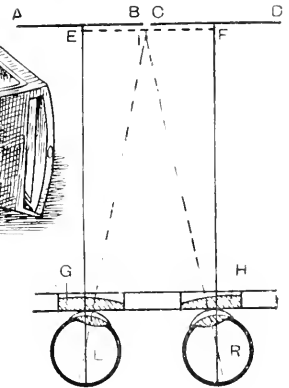

Fig. 813.

Fig. 812.—BREWSTER'S STEREOSCOPE.

Fig. 813.—PRINCIPLE OF BREWSTER'S STEREOSCOPE.

Two convex prisms, G and H, are fitted into the framework, the two pictures to be examined being situated at A B and C D. The function of the convex prisms G and H is to refract the light emanating from the actual pictures, so that the eyes situated at L and R see their respective pictures at E F combined, magnified, and giving together stereoscopic effect. The lenticular stereoscope has been made in numerous forms, and its box form with partition and reflector (Fig. 812) has long been superseded by more portable appliances. The American form of lenticular stereoscope (Fig. 814) was designed by Oliver Wendell Holmes. The view carrier D can be moved backward or forward for focussing purposes. The hood at the

front serves to exclude superfluous light, the inlet *A* being a recent addition to aid the camera obscura effect. For convenience in packing, the handle *B* is hinged to the underside, and may be folded backwards to the dotted position *c*, while the holder *D* may be taken off.

VARYING THE REFRACTIVE ANGLE.

The stereoscope shown by Fig. 844 is not provided with adjustable means for varying the refractive angle. This is not necessary in the majority of cases, but

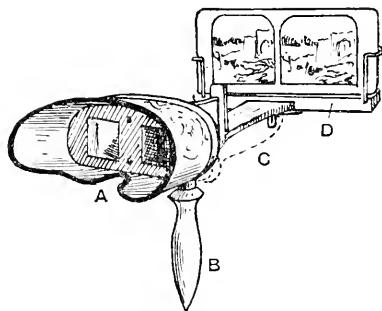

Fig. 844.—MODERN STEREOSCOPE, AMERICAN PATTERN.

there are people whose eyes are abnormally separated or very close together. In such cases, unless provision is made for altering the separation of the stereoscopic eye-pieces, difficulty is experienced in combining the pictures. For this reason the best stereoscopes are those which provide, not only for focal adjustment, but also for a variation of the refractive angle. This is sometimes obtained by means of rackwork, with which the eye-pieces are made to move closer together or further apart in a horizontal direction. Other instruments are provided with lens or prism mounts that may be revolved, so that the index of refraction may be increased or decreased exactly at that point where the eyes look through the glasses. The lenses of a stereoscope should be achromatic, so that colour fringes are avoided, while their total focal length should correspond as nearly as possible to the focal length of the lenses by which the original pictures were taken in the camera.

REVOLVING AND AUTOMATIC STEREOSCOPES.

The principle of Brewster's instrument has been elaborated in a variety of ways. Fig. 845 shows an instrument which is intended for use in the drawing-room. It is fitted with a continuous revolving view holder, with a capacity for fifty stereoscopic transparencies or paper slides. The views are brought successively into position before the eye-pieces by turning the handle at *A*. The eye-pieces at *D* are adjustable for focus by operating the thumbscrew at *E*, while the refractive angle of the lenses may be varied by turning the mounts at *D*. When prints are viewed in this instrument, *B* is closed up, and the mirror *C* is opened to the position shown in the illustration. On the other hand, if the pictures to be examined are of the transparent sort, then *C* is closed down and *B* placed in the position shown in the figure. Thus, when *C* is closed and *B* opened, the pictures are illuminated by transmitted light, and when *B* is closed and *C* open, they are viewed by reflected light, *C* and *B* being reflectors. Commercial instinct is doubtless responsible for the automatic stereoscope. This instrument is similar to the above, the only difference being that the views cannot be seen without first placing a penny in the slot, also that above the stereoscopic eye-pieces a graphoscope lens, with a picture at the back, provides the first attraction for the prospective customer. Many other forms have been suggested for the stereoscope, particularly by Sir Howard Grubb, who recommended various modifications, but the American pattern seems at present to hold the field.

THE PHENOMENON OF STEREOSCOPIC VISION.

Stereoscopic vision, by which is meant the uniting of dissimilar pictures with the two eyes without any optical agency, appears to be possessed by few people, but, by a little practice, the majority may acquire the power. By crossing the axes of the eyes at a point closer than that distance at which the picture is

situated, superposition of the two dissimilar images may be accomplished. This is precisely the principle and effect of the lensless stereoscope invented by Mr. Elliott (see Fig. 840). The stereoscopic effect obtained by crossing the axes at a near point, however, makes it necessary that the prints, to be so viewed, should be transposed as regards right and left, so that pictures mounted in the usual manner for the stereoscope are not suitable for examination. The better and more convenient kind of stereoscopic vision is that which enables the stereogram to be examined with the pictures mounted in the usual manner, *i.e.* the picture seen in binocular vision by the right

height as the original view. The portion selected should contain distant as well as near objects, and a foreground object should occupy the centre position in each strip. Now provide a piece of cardboard (preferably black) $1\frac{1}{2}$ in. wide and about 3 in. in height. Reference being made to the diagram Fig. 846, place the two strips of view A and B side by side on a table in a vertical position, resting against a box or any other support D. At a distance of about 3 ft. from these strips of view place the piece of black cardboard E also in a vertical position. This may be done in the manner shown in Fig. 847. The eyes of the observer are then placed at L R, at a distance from the card E of about 7 in., and in such a position that the left eye L sees only strip A, and

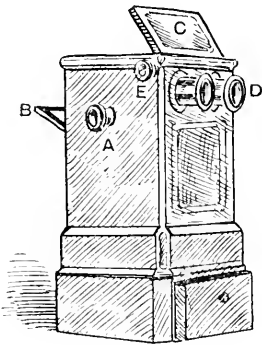

Fig. 845.

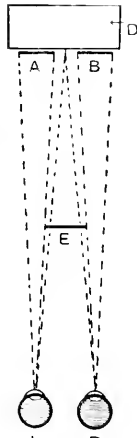

Fig. 846.

Fig. 845.—REVOLVING STEREOSCOPE.

Fig. 846.—PRINCIPLE OF STEREOSCOPIC VISION WITHOUT A STEREOSCOPE.

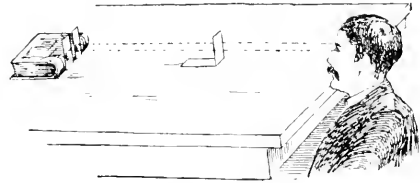

Fig. 847.—EXPERIMENT IN STEREOSCOPIC VISION.

eye placed on the right-hand end of the mount. This necessitates that the eyes must be directed to a remote plane while their foci are accommodated to a near one. Although this is rather an unnatural adjustment of the eyes, it is in no way harmful, and may be accomplished in the following manner.

HOW TO ATTAIN STEREOSCOPIC VISION.

Cut a strip, 1 in. in width, out of both the left- and right-hand prints of a spare stereogram, leaving them the same

the right eye R sees only strip B, each eye being prevented from seeing the other strip by the intercepting card E. As the two corresponding points in the pictures A and B have a separation of only 1 in., instead of $2\frac{3}{4}$ in., as in the ordinary uncut stereogram, the eyes are easily made to unite these two points, thus superimposing the two strips of view A and B. This will, of course, result in a composite of the two, and stereoscopic vision will have been acquired. Having succeeded in uniting the strips of view in this position, their separation may be gradually increased by shifting them farther apart, until the distance between corresponding points is $2\frac{3}{4}$ in. This done, the strips may be exchanged for full-sized pictures, and the experiment repeated with the aid of the card E till the observer has acquired sufficient control over the muscles to enable him to hold the eyes in the position required without its use. If at any time afterwards it is desired to view stereograms without the aid of an instru-

ment, and any difficulty is experienced, the first and second fingers of the right hand may be used in place of the card E.

RELIEF EFFECTS WITH NON-STEREOSCOPIC PICTURES.

It may here be mentioned that various devices have been made use of for obtaining a sensation of relief from photographs taken non-stereoscopically. In the "Graphoscope," a single photograph is examined through a double convex lens, giving a certain amount of

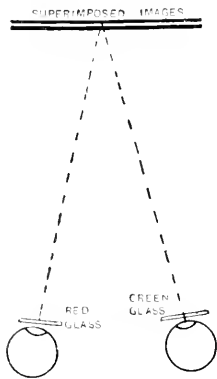

Fig. 848.—D'ALMEIDA'S STEREOSCOPIC PROJECTION.

relief accompanied by magnification. This phenomenon, it has been suggested, is due to the non-achromatic lens causing overlapping of the different rays. In the "Verant" of Dr. von Rohr, a single photograph is held in a special viewing instrument for inspection by one eye only; there is also a double Verant designed on the same principle, in which two prints are used. In the "Stereo-factor" of Mr. A. Lockett, two exactly similar, non-stereoscopic prints are mounted side by side and viewed in an ordinary stereoscope, in a special holder, inclined to each other at an angle of 140° . None of these contrivances, however, although interesting and capable of giving a very fair appreciation of relief, can equal the effect produced by the examination of a good stereoscopic slide in the stereoscope.

LANTERN STEREOSCOPIC PROJECTION.

The principle of stereoscopy, which has already been set forth, shows that the problem to be solved in lantern stereoscopic projection is to so arrange matters that each eye sees only one image, and that belonging to it, or corresponding to the one it would see in nature. The researches of Dore (1841) were productive of many suggestions in this direction, and seem to have foreshadowed the recently revived anaglyph of Ducos du Hauron, which consists of a composite picture printed on a sheet of paper from two

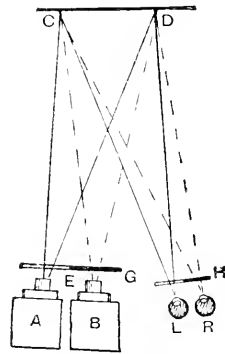

Fig. 849.—PRINCIPLE OF D'ALMEIDA'S ECLIPSE STEREOPTICON.

process blocks made from the two elements of a stereograph, one impression printed in blue and the other in red, such pictures being viewed with a pair of red and blue glasses. In 1858, J. Ch. D'Almeida, experimenting in the same direction, devised similar means, but used red and green discriminating glasses instead of red and blue, as in the former case. When lantern projections were involved, the inventor placed in the course of the luminous rays the two coloured glasses, which have no element, or scarcely any element of the spectrum in common. By means of these coloured glasses, one of the images projected upon the screen is rendered green and the other red, and, similar glasses being placed before the eyes, the green image alone will be perceived by the eye covered by the red glass, and the other by the

eye furnished with the green glass. This principle is shown by Fig. 548.

ECLIPSE SYSTEM OF STEREOSCOPIC PROJECTION.

To the same inventor is due the conception, in 1858, of the Eclipse System of Stereoscopic Projection, which is carried out in the following manner. The two elements forming the stereoscopic pair are made into positive transparencies and placed respectively in the two lanterns A B (Fig. 549). The direction of the objectives is so arranged that their axes meet in the centre of a common screen

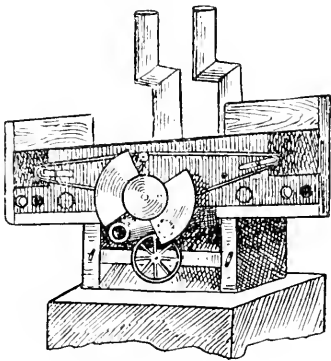

Fig. 550.—APPARATUS FOR D'ALMEIDA'S ECLIPSE SYSTEM.

c d, so that the position of both pictures is the same. A shutter G revolving on an axis at E uncovers the objectives of the lanterns alternately. A similar shutter H is arranged to revolve before the observer's eyes at L and R, both shutters being made to turn synchronously, the result being that the left eye L sees only the left element of the stereogram projected upon the screen, and the right eye R sees only the right element. Hence the two, although not seen at the same moment of time, succeed each other so rapidly that continuity of impression is preserved, which, of course, produces a stereoscopic effect. The manner in which the simultaneous action of the shutters is accomplished will be seen by reference to Fig. 550. It is obvious that the eclipse system is applicable to the upright bi-
unial lanterns of more recent design.

SIDE-BY-SIDE STEREOSCOPIC PROJECTION.

The eclipse system described in the last paragraph has disadvantages of a serious nature. As Fig. 550 shows, it is necessary that the shutter used by each spectator should work synchronously with the one revolving in front of the lanterns, a condition not easily complied with when a large audience is involved. For this reason the system has fallen into disuse. But stereoscopic effects are so highly appreciated, that inventors have constantly devised fresh means, and side-by-side

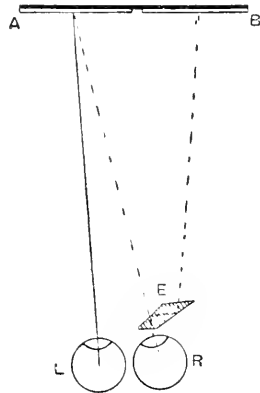

Fig. 551.—METHOD OF VIEWING SIDE-BY-SIDE PROJECTION.

projection next made its appearance. A typical example of this system is shown by Fig. 551. The dissimilar pictures are projected side by side upon a screen A B, and viewed by the two eyes at L R. In front of the right eye R a reflect-prism E is placed. The rays coming from B are bent in their course, so that the image of B is seen, not at the point it actually occupies, but superimposed upon A, which is viewed direct with the other eye L. The result is, consequently, a stereoscopic effect. The side-by-side projection system is capable of much variation as regards the viewing devices. Thus, if the prism E was exchanged for a pair of plane mirrors facing each other, but not quite parallel, the same result would follow. Other variations might be made in which more than one prism or two mirrors are used, but the example given will suffice.

ANDERTON'S POLARISING SYSTEM.

By far the best method of stereoscopic projection in which intermediate aids are necessary is that due to the inventive genius of Mr. John Anderton, of Birmingham. One of two slides, prepared from pictures taken in the stereoscopic camera, is placed in one lantern, and the other slide in a second lantern. Into the optical system of each lantern is introduced, either between the condenser and objective, before the objective, or between the radiant and condenser, but preferably between the lenses of a Petzval objective, a Nicol's prism plate of tourmaline. The plates are so arranged in each lantern that the light from one will emerge polarised in a plane at right angles to that of the light emerging from the other. The images of the two slides or pictures are superimposed upon each other when projected upon the screen, but, on account of the light being polarised, one image will be erect while the other is lying on its side, the resulting image or composite being a confusion of the two. These superimposed images are viewed through a pair of analysers, having their planes at right angles to each other. One analyser permits one eye to see one of the projected pictures, and the other analyser permits the other eye to see its companion, this resulting in stereoscopic effect in the mind of the observer. The analysers designed for this purpose are made of a number of thin glass plates, and the necessary polarisation is effected by refraction. These glass plates are set at a proper angle in a mount resembling a very small opera glass. It should be stated that in carrying out the Anderton method it is necessary that the screen should have a metallic surface, otherwise the light would be depolarised. Mr. Anderton employs a flexible screen covered with silver leaf and subsequently lacquered.

STEREO-ANIMA-PHOTOGRAPHY.

In another section of this book will be found a comprehensive description of animated photographs, and the process of

taking the same. It is, therefore, only necessary to refer to the subject from a binocular standpoint. The principle of the stereoscope and the laws of persistence of vision having been well established, the combination of the illusion of motion, with that of stereoscopic effects, came as a matter of course to the mind of inventive genius. The first attempts to bring this about appear to have been made by Fisher and Aspray as early as in the year 1859. The combined illusion was produced in an apparatus in which provision was made for the momentary inspection of each picture in a double or dissimilar series, these being exhibited to the eyes alternately through a revolving disc which shut off the image from one eye while the other was viewing its respective picture. Fifteen years later Mr. A. Ray patented a device of a similar nature, but his specification contained further suggestions, namely, that the two series of dissimilar elements might be in red and green, and inspected with a pair of discriminating glasses of the same tints. It will be noticed that this system was very similar to that of D'Almeida's projection, having, however, the additional element of apparent motion.

WILSON'S SYSTEM OF PROJECTION.

It seems strange that the results obtained by these motional illusion experimenters should not have been productive of animated stereo-lantern projections till the year 1898, when Mr. G. R. Wilson patented his invention. Wilson employed two cameras side by side, and thus produced a pair of films in which the images were stereoscopically dissimilar, in addition to having in each succeeding picture that progressive difference due to motion in the subject. In the present case, the pictures were projected upon the screen by what may be termed a bi-unial cinematograph projector. The axes of the twin objectives being directed to the centre of the screen, the animated pictures were superimposed. To enable each eye to see but one series of pictures, peculiar to its view point, the eclipse system, similar

to that shown by Fig. 849, of D'Almeida, was employed. The inventor varied his methods by obtaining the stereoscopic images side by side upon one film. It is evident that stereoscopic animated projection may be carried out in a variety of ways, so long as the main principles are adhered to.

STEREOSCOPIC CINEMATOGRAPH FILMS WITH A SINGLE LENS.

The dissimilar elements for stereoscopic projection may be transmitted through a single lens by the aid of mirrors, after the principle of the device illustrated by Fig. 826 (p. 619). The mechanism of the camera communicates with that of the centre mirror, giving it a quarter turn to each opening of the camera shutter. By adopting this method, the stereoscopic phases are all contained on a single film in alternating order. In the exhibition of a positive film made from a composite negative so obtained, a revolving disc with red and green sectors is interposed between the objective of the lantern and the screen, thus giving one eye series in red and the other series in green. The projections are viewed with discriminating glasses of tints corresponding to the projections on the screen, the result being identical with that of D'Almeida's system, but, of course, with the additional element of animation.

THE TWIN LENS STEREO-CINEMATOGRAPH CAMERA.

The cinematograph camera used for obtaining stereoscopic films is simply a duplication of any of the single instruments used for taking animated photographs. Some patterns lend themselves better than others to this duplication, but, in any case, provision has to be made for the passing through of two films instead of only one. It has been suggested that an extra wide film might be used, large enough to receive the dissimilar images side by side, as in the case of Wilson's camera already mentioned. This, however, involves a special form of projecting apparatus, as well as a special camera for taking the negatives. Many

of the cameras now on the market are of such a design that to make stereoscopic pictures it is only necessary to use two such cameras simultaneously, by having them geared together. A better method, however, is that in which the duplicate mechanism is fitted into one box with the objectives on the front similarly to an ordinary stereoscopic camera. Many of the conditions of successful stereoscopy apply equally to stereoscopic pictures of an animated nature, such, for instance, as concentration of axes and focus upon the most prominent and important objects in the composition. The latter condition differs somewhat when cinematography is involved, owing to the amount of enlargement required when projected, it being a very important point to have lenses of deep focal value and keen definition.

DIRECT STEREOSCOPIC PROJECTION.

In all the foregoing methods of stereoscopic projection, whether merely of still subjects or those of an animated nature, it has been shown that some kind of intermediate aids in the inspection of the projected pictures have to be used by the observer. Obviously these conditions discount their value, inasmuch that the exhibitions must be limited to few persons or small audiences, to say nothing of the inconvenience to which the observer is put. In view of these facts, a little reflection will show that what is needed is a method of stereoscopic projection that may be termed direct, *i.e.* not necessitating the use of any intermediate agencies such as described above. There are many optical illusions which give rise to the sensation of relief that are not, however, stereoscopic phenomena, scientifically speaking. When looking into the transparent mirror of plate glass used in the familiar illusion of Pepper's Ghost, one sees not only the real objects of furniture placed upon the stage, but a supplementary figure (the ghost) invested with roundness and relief, though the manner of its projection renders it more or less transparent. Pepper's Ghost effects derive their results from a

combination of transmitted and reflected light, the transmitted light emanating from the real objects upon the stage, while the reflected light proceeds from the surface of the leaning plate glass, and emanates from a brilliantly illuminated figure in white, concealed beneath the stage. This class of projection enables a large audience to see the results without intermediate aids, and while it is not

MOTIONAL PERSPECTIVE.

To create the sensation of solidity from mere images thrown upon a screen by means of an optical lantern, and without further assistance to the eyes, is seemingly impossible, in view of the facts relative to binocular perception already pointed out. This, however, is done by apparatus devised by Theodore Brown, of

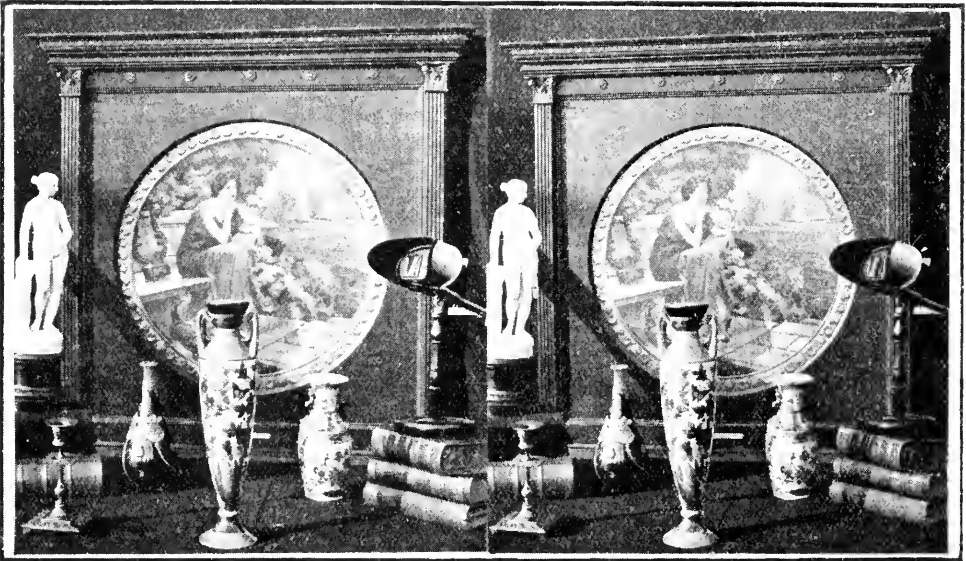

Fig. 853.—TYPICAL STATIONARY SUBJECT FOR RELIEF PROJECTION.

stereoscopic projection, as generally understood, yet it is an arrangement of lighting which permits of binocular inspection, requiring, as it does, the full activities of axial and focal accommodation. In a similar way one person may look into a plane mirror and see another person's reflection, seemingly solid, giving the eyes their full play, as in nature. Such images are seen from a single plane, the surface of the mirror, and, owing to the varied view points of the two eyes, a pair of dissimilar reflections will be received by each observer. An actual relief object, however, is necessary, in the first place, before this class of effect can be seen.

Salisbury, and to understand this it will be necessary to consider briefly some hitherto obscure laws of vision with which this system complies. In estimating the distance of a given object in nature, a one-eyed person depends more or less on its magnitude in comparison with other objects, its effect on perspective, its colour, the degree of its definition upon the retina, and atmospheric criteria. If, however, the object is of an animated nature, the speed of its motion adds very important evidence to the judgment. This may be shown by reference to Fig. 852. Let an observer's eye be situated at L, viewing two soldiers at A and B. While these men remain stationary, the observer

will know that A is farther away than B, owing to its lesser imagery magnitude upon the retina and the other criteria of estimating its distance. If both men march four steps forward, *i.e.* across the plane of vision, the mind at once gains the further information that the displacement of the image of B upon the retina has been greater than the displacement of A, and during the proportionate movements the mind has thus been able to form an accurate idea of the

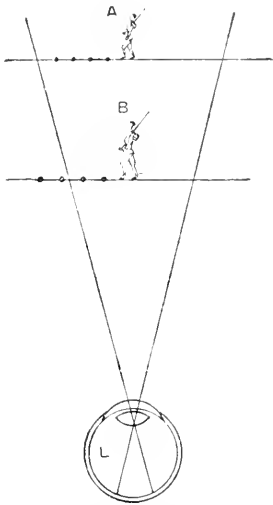

Fig. 852.—EXAMPLE OF MOTIONAL PERSPECTIVE.

relative distance of the two soldiers. From these facts it will be seen that, by the proportionate displacement of objects in a composition, *i.e.* their relative speeds, the sensation of relief may be gained from a series of flat projections upon a screen. Whether the subject is animated or stationary, displacement of objects in proportion to their supposed distance from the observer's eye will bring about the desired sensation of relief when a series of pictures successively so dissimilar are projected upon a screen in rapid succession.

BROWN'S METHOD OF RELIEF PROJECTION.

In nature there is a constant oscillation of images upon the retinae of the two eyes

as the observer makes the various axial adjustments necessary to bring all planes under especial attention. The oscillation of images upon the retina, however, is rendered more or less unnoticeable by the simultaneous focal accommodations that are operative during the process of binocular vision, throwing each plane out

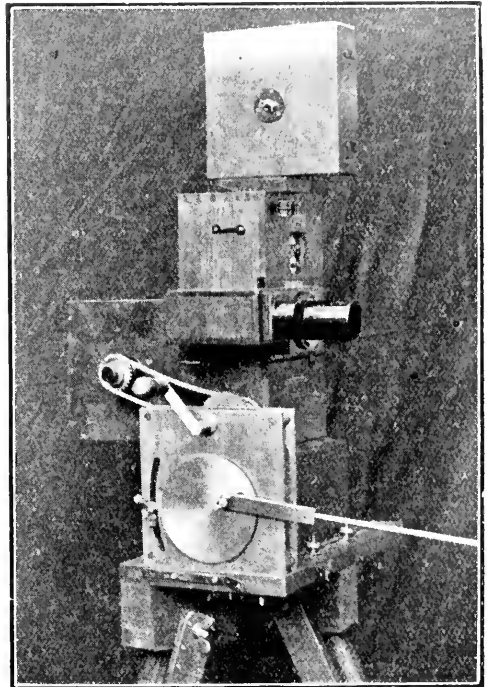

Fig. 854.—CINEMATOGRAPH CAMERA AND MECHANISM FOR OSCILLATING SUBJECT.

of focus as the attention is diverted to a different one. To make the illusion of relief from a lantern projection more perfect, it becomes necessary to utilise photographic means, and this may be done for stationary or moving objects. When a stationary subject, such, for instance, as shown in Fig. 853, is prepared, a series of pictures composed of the two extreme views shown in the illustration, together with a number of intermediate phases, will have to be secured. The subject is placed upon a stand or shelf, at right angles to which a background is

fixed. This background is hinged at the back and in the centre to some rigid support, such as a post. The background, with its attached shelf, forming a table on which the articles are set up, may thus be oscillated on its vertical hinges like the movement of an ordinary door. The front part of the shelf is connected with a rod

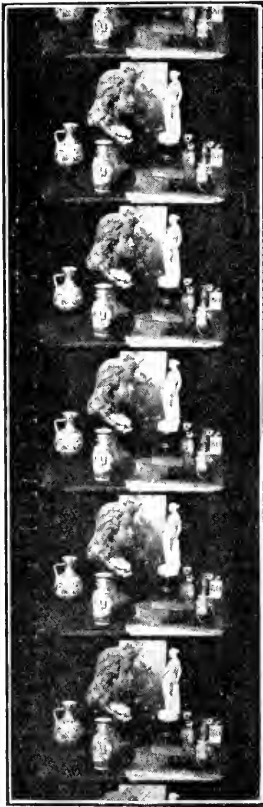

Fig. 855.—SERIES OF PHASES FOR RELIEF PROJECTION.

extending to the mechanism shown in Fig. 854. This illustration shows a Gaumont type of animated picture camera, with Brown's oscillating mechanism placed at the side. On turning the handle (shown in the photograph) the camera is operated in the usual manner, while the rod, acting on a crank, oscillates the shelf upon which the subject is placed, a complete cycle of dissimilar

phases of the subject being thus obtained. A section of a cycle is shown in Fig. 855. A comparison of two succeeding phases will show how very slight the dissimilarity is, but if the top one is compared with the bottom one the difference becomes more pronounced. Look, for instance, at the statuette. The face of the figure is closer to the edge of the picture at the background in the top phase than it is in the bottom one.

CIRCUMSCRIBING THE SUBJECT.

When the subject is too large to place upon an oscillating table, it may be photo-

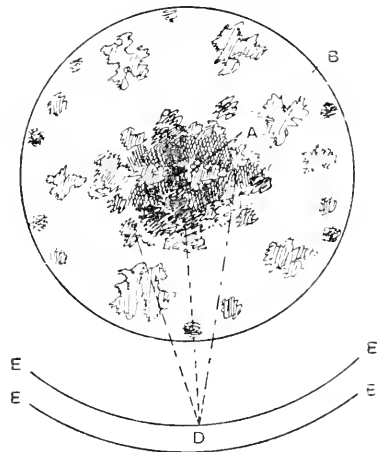

Fig. 856.—CIRCUMSCRIBING METHOD FOR TAKING PROGRESSIVE SERIES OF PICTURES.

graphed from all view points with a camera travelling on lines which circumscribe the subject. Let B (Fig. 856) represent a group of flowers, and E E E E the lines on which the carriage of the camera runs. If these lines are extended, making a circle round the subject, the lens of the camera at D will be a uniform distance from the subject throughout the entire operation. The camera employed is fitted with the special mechanism shown by Fig. 857. The operator, standing on the vehicle at M, turns the handle E, which operates the camera by the gearing at D, G, and H, and at the same time drives a chain I, which in turn moves the cycle slowly forward, such movement

being suitably adjusted according to the number of pictures to be taken and the distance of the subject from the camera. When the camera has travelled entirely round the subject, a large cycle of dissimilar phases is secured, and if the beginning of the film is joined to the end, an endless band will be formed, stereoscopic on projection at any point.

ANIMATED STEREOGRAMS.

When the subject is of an animated nature, it is necessary that the camera should oscillate during its operation. The instrument for securing this is shown

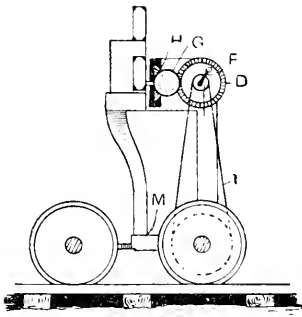

Fig. 857.—CARRIAGE FOR CAMERA WHEN CIRCUMSCRIBING THE SUBJECT.

in Fig. 858. On turning the handle at the side, a rod working on a crank pushes the camera backward and forward upon parallel bars, while a revolving piston rod operates the spindle of the camera and follows its motion along the bars. Film pictures obtained by this apparatus depict the illusion of motion with the additional element of solidity, the result being due to the fact that the retentive power of the mind is superior as regards duration of impression to that of the eye. Thus, after the eye has lost the impression received, it is retained in the mind, and persists there till supplemented with the succeeding phase from a similar point of view. In other words, the internal oscillation of images upon the retina, due to the circumstances of binocular perception, instead of being produced in the eye by the varying direction of the axes, is produced externally upon the lantern

screen by a change in the relative positions of objects constituting the view.

CONCLUDING REMARKS

It must not be thought that the stereoscope is merely an entertaining toy. Science has succeeded in turning it to account for varied purposes. In astronomy, an adaptation of the instrument is used to determine the distance and con-

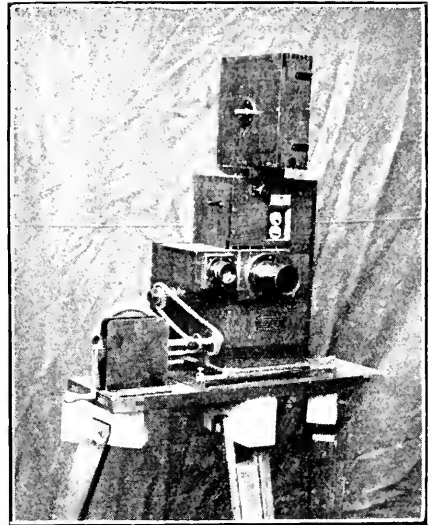

Fig. 858.—BROWN'S OSCILLATING ATTACHMENT FOR CINEMATOGRAPH CAMERAS.

figuration of celestial bodies by means of photographs taken from widely separated view points and combined stereoscopically, a calculation of distances being possible by an ingenious formula depending on the parallax or angle of view as compared with measurements on the two pictures. The educational value of the stereoscope is obvious, where a clear and definite idea of objects and places not readily accessible is desired. In medicine, also, the stereoscope has sundry uses; as, for example, in the curing of squint or "cross-eye." It is surprising that this most instructive and recreative instrument is not more popular, considering its inexpensive character. It has, however, lately received more attention, and seems to be growing in favour.

NATURAL HISTORY PHOTOGRAPHY.

INTRODUCTION.

NATURAL HISTORY PHOTOGRAPHY may be broadly divided into plant life, animal life, birds and their nests, reptiles, fish, insects. Each division requires special treatment, and practically special apparatus; but the first and most important part of the whole outfit is a really genuine love for nature, combined with untiring patience and perseverance. Without these special gifts true success is unobtainable.

PLANT LIFE.

For photographing plant life, a camera with long extension, swing back, and good rising front will be found the most useful type. It is desirable to have a fairly long focus lens, and, as allowing the greatest amount of light to reach the plate, a focal plane shutter should always be employed in the field. A couple of tripods, one of the ordinary height, and one that will allow of the camera being placed within 12 inches of the ground, will be necessary. As it is of vital importance that the photograph may show an approximately correct representation of the colour values of the flowers and foliage, only orthochromatic plates should be employed, in conjunction with a proper "light filter" or orthochromatic screen. A set of these screens will be found very handy, enabling the operator to select that one which is most suitable for the particular subject which is to be photographed. To avoid wind and vibration, a canvas screen attached to four sharp-pointed uprights will be found exceedingly useful when photographing comparatively low-growing plants in the field, as it can be quickly erected to shield the plant to be photographed. Indoor flower photography has been alluded to elsewhere (see pp. 450 and 622). Flowers are

very sensitive to vibration, so that the exposure should not be prolonged. Dead-black backgrounds are, as a rule, unsuitable.

BOTANICAL PHOTOGRAPHS.

As the principal reason for photographing a growing plant is to show not only its form but also its natural environment, it is important in selecting the plant to be sure it is growing under normal conditions and in surroundings common to its species, or an entirely false idea of the plant's natural habitat will be given. In selecting the plant one should be chosen, when possible, showing the buds and flowers in various stages of development. In making practically "portrait studies" of individual trees, separate photographs (carefully taken to one scale) should be made of the foliage, leaves, flowers, and fruit, which will greatly add to the value and interest of the series. As regards the lighting of trees, the best results are generally to be obtained when the shadows are long and the sun is low, a far better scale of gradation being then obtainable, as the under sides of the leaves will be slightly illuminated.

PHOTOGRAPHING FLOWERS.

Flowers require particularly careful treatment, both as regards arrangement and lighting, for error in lighting is sufficient to give quite an erroneous idea of the true shape of the flower photographed. However, with a little care, thought, and trouble, most charming, truthful, and beautiful photographs can be obtained. Flowers are singularly sensitive to vibration, a door banging or someone walking in an adjoining room to that in which they are being photographed, causing them to tremble. It is, therefore, very important to have a good light so that the exposure may be

cut down as much as possible. Everything in the room must be absolutely still; and if it is necessary to give a very prolonged exposure, as is sometimes the case, the photographer should sit beside the camera rather than stand, as the slightest movement in the vicinity of the flowers is liable to cause them to shake and spoil the picture. Excessive contrasts of light and shade and dead black backgrounds should be avoided, as tending to give an unreal and displeasing result. A very great deal depends also on the careful selection of the most appropriate colour-screens or filters. In photographing blue or white flowers with green foliage, a deep-coloured screen is of very great assistance in correcting the ordinary untruthful colour values given by

and tame, are constantly on the move and changing their positions except when asleep, and therefore it is of great importance to be able to focus right up to the instant of exposure. The twin-lens camera, although in its time having done admirable work, is now practically an instrument of the past; owing to its weight, the necessity of having most accurately paired lenses, and the introduction of the reflex type of camera, which requires only one lens.

REFLEX, AND OTHER SPECIAL CAMERAS.

Two typical and high-class reflex cameras of the latest and most approved pattern are the "Birdland" camera, made by Messrs. Sanders

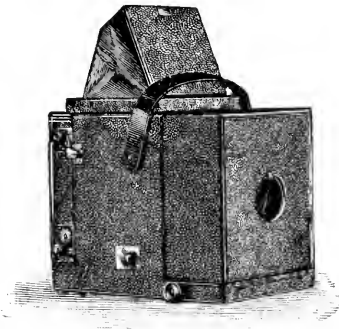

Fig. 859.—THE "BIRDLAND" CAMERA, CLOSED.

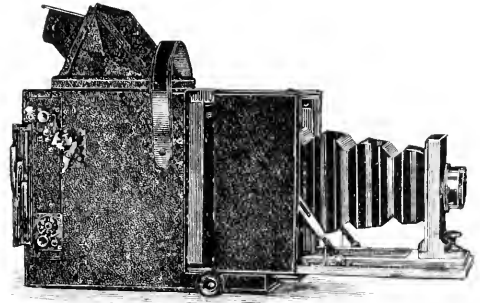

Fig. 860.—THE "BIRDLAND" CAMERA, EXTENDED.

the unassisted plate. With red or orange coloured flowers, the plate being much less sensitive to red than blue, a lighter screen can be used.

PHOTOGRAPHY OF ANIMALS.

The question of selecting a suitable camera for photographing animal life is of extreme importance. The ordinary stand camera is practically useless, and certainly quite out of the question so far as wild animals are concerned. The regulation type of hand camera is really little or no better, having two very great drawbacks, namely, that it is generally made for use with a short focus lens, which is quite worthless for wild animal work; and one has to guess at the focus—a most unsatisfactory, uncertain, and difficult thing to do. If really successful work is to be accomplished, either a reflex or a twin-lens camera must be used, and the former for preference. Animals, both wild

and Crowhurst (shown closed and partly extended by Figs. 859 and 860), and the "Argus," by Watson and Sons (Fig. 862). The "Birdland" has a very considerable extension of bellows, making it a useful camera for fairly high power telephoto work; which is a very important advantage to the naturalist photographer, enabling him to get photographs of very shy animals. The finder is of the reflex type, so linked up to work in conjunction with the shutter, that the removal of the mirror and the discharge of the blind of the focal plane Anschutz shutter follow instantly on the pressing of the trigger. This linking up of the mirror and shutter has been very carefully worked out, so that the discharge is almost noiseless and without vibration. The "Argus" has a reflex finder, the mirror of which is silvered on the surface. The focal-plane shutter is of a new pattern, the width of the slit in the "blind" being regulated from the outside,

giving a range of speeds from $\frac{1}{15}$ to $\frac{1}{1000}$ of a second, and time exposure at will. The camera is strongly made, and has been well planned for the work for which it is intended, and is wonderfully portable, a consideration where the photographer may have to tramp many weary miles, and climb into queer places to photograph his restless and timid models. Another admirable piece of apparatus is Dallmeyer's Naturalist's hand camera (Fig. 861), which was awarded the medal of the Royal Photographic Society in 1894. As will be seen,

lighting, a most important feature to the Naturalist Photographer. The most rapid plates should, of course, be used.

THE LOW-POWER TELEPHOTO LENS.

In animal work, a low-power telephoto attachment is a most valuable adjunct, enabling the photographer to obtain satisfactory photographs of very shy creatures that cannot be approached sufficiently close for photographing with the ordinary lens. For photographing wild deer, mountain sheep and goats, bears, rhinoceros, elephants, elk,

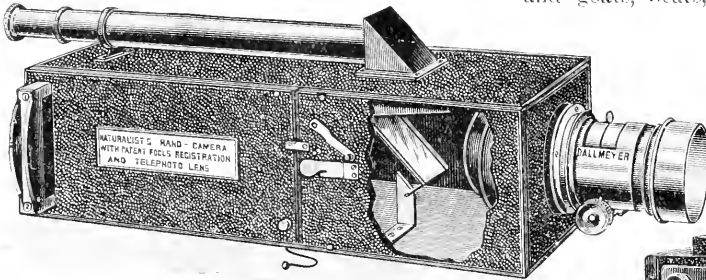

Fig. 861.—DALLMEYER'S NATURALIST'S HAND CAMERA.

it has a telescopic eyepiece for viewing the image up to the moment of exposure. This pattern has lately been improved upon, resulting in the new instrument shown by Fig. 863, which has a more conveniently designed eyepiece, and may be used with either ordinary or telephoto lenses.

LENSES FOR ANIMAL PHOTOGRAPHY.

For Animal Photography a long focus lens with a large working aperture is essential; and it must give crisp definition to the very edge of the plate when used at its fullest aperture, for, be it remembered, it is by no means always possible when photographing wild animals to have the object exactly in the middle of the field when the moment for making the exposure arrives. Two of the finest lenses yet produced for Natural History work are the "Holoastigmatic" lens, made by Messrs. W. Watson and Sons, and the Goerz "Double Anastigmat," Series III. Both these lenses yield exquisitely crisp detail to the extreme margins of the plate when used at full aperture, and passing a great amount of light, render it possible to obtain good exposures under very different conditions of

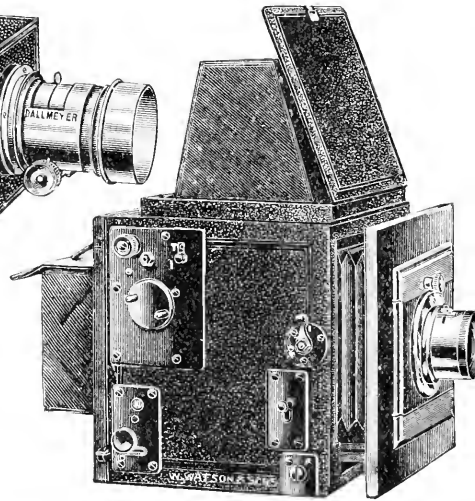
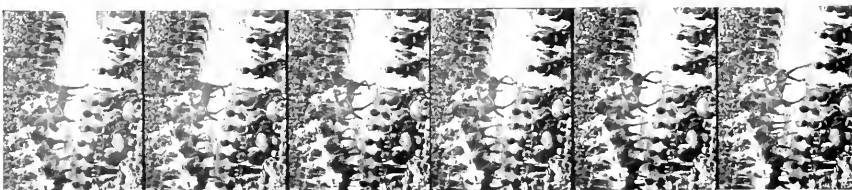
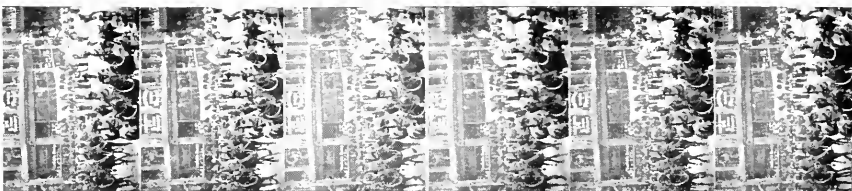

Fig. 862.—THE "ARGUS" CAMERA.

besides numerous small, shy animals, the low-power telephoto lens is invaluable. Owing to the almost constant movement of animals, only low-power telephotography is possible, and very rarely indeed can a greater magnification than four diameters be attempted with any hope of success; two to three diameters will be found the most useful magnifications for general purposes. As the telephoto attachment cuts down the aperture, and therefore prolongs the exposure, it is important that a very rapid positive lens with a large aperture ($f/5.4$ or $f/6$) should be used with it.

THE FOCAL PLANE SHUTTER.

As the exposures in Animal Photography have nearly always to be of the shortest



possible duration, a focal plane shutter is by far the best and most suitable form to employ, as working in close proximity to the front of the dark-slide, it permits the greatest possible amount of light to reach the plate. It is possible to give far shorter exposures with the focal plane shutter, and obtain really satisfactory results, than with any of the shutters that fit on the lens-hood or on the back of the lens. Nothing is more deceptive than the real speed at which the shutter works, as compared with the speed marked on the indicator, and as in this class of work a knowledge of the exact duration of the exposure is often of vital importance, it is most necessary, before starting serious operations, to thoroughly test the various speeds of the shutter and critically

SPECIAL TREATMENT FOR DIFFERENT ANIMALS.

It is impossible to give any hard and fast rules for photographing animals; each species is so different in its characteristics, that what would be suitable treatment for one kind would be absolutely wrong for another; while frequently individuals of the same species are so distinctive in their habits as to require quite a special method of treatment. Success in all branches of Natural History Photography depends upon the patience, determination, promptitude, and resourcefulness of the worker.

BIRDS AND THEIR NESTS.

For photographing birds in their nests, a somewhat more elaborate outfit is required than for animal work. The reflex camera so ab-

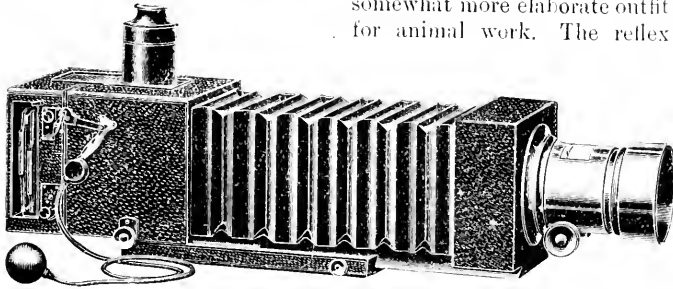

Fig. 863.—DALLMEYER'S IMPROVED NATURALIST'S HAND CAMERA.

compare them with those marked on the indicator, or the table of speeds sent out with the shutter. As an auxiliary to the focal plane, a shutter that will fit on the front hood of the lens, and worked by pneumatic release on the lines of the "Thornton-Pickard," will be found most useful, as it admits of very short time exposures being given.

PLATES.

The plates to be used for animal work must be of extreme rapidity, as very rarely can a time exposure be given, and it is, of course, most important to have the plate as fully exposed as possible. Although an isochromatic plate would certainly give a more satisfactory rendering of the colour values of the landscape and animals, it would require a longer exposure than it is generally possible to give, and therefore it is far better to employ an "extra rapid" or "instantaneous" plate.

solutely essential for photographing animals, although very useful for certain sections of bird work, is not an actual necessity. As a very large majority of birds perch on the branches of trees and bushes, and are all rather shy of the bright eye of the camera, frequently taking flight if they catch a glint of light on the lens, probably under the impression that the camera is some new bird-slaying apparatus, it is even more difficult than in animal work to approach sufficiently near to get a sufficiently large image on the finder of the reflex camera. A good long-focus stand camera is the very best for bird work, and is the type used by all the most successful photographers of bird life. Practically, all the magnificent work of the brothers Richard and Cherry Kearton has been accomplished with a long-focus stand camera.

SUITABLE APPARATUS.

The camera should be strongly built, with a long extension of bellows for telephoto work;

and it should also have a good swing back and considerable rising front. The dark slides must be well made, and on no account should those with pull-out shutters be employed, since unless the shutters are withdrawn and reinserted with the greatest caution, and under the protection of a heavy focussing cloth, the ingress of sufficient light to seriously fog the plate may be considered almost an inevitable certainty. The standard book form dark-slide, with shutters properly hinged to fold back out of the way during exposure, is the only safe type to use in the field, where one cannot employ a focussing cloth. The best lens for photographing birds is one of considerable focal length; and for this purpose the single combination of the Double Anastigmat or other make of convertible lens will give admirable results. The reason for employing a long-focus lens when photographing birds on their nests is that the camera can be placed at a considerable distance away from the bird and a fairly large image obtained. Where there is sufficient light to admit of its use, the low-power telephoto attachment will be of most valuable assistance.

PHOTOGRAPHING NESTS, EGGS, AND YOUNG BIRDS.

In photographing nests containing eggs, an isochromatic plate should always be used if possible, so as to obtain a satisfactory rendering of the colour values. On no account must the nest, the eggs, or the natural surroundings be disturbed, or the value of the photograph will be imperilled. The eggs are always deposited in a characteristic way by the parent bird, and any rearrangement will produce a false and unnatural appearance. Twigs and branches overhanging or screening a nest should never be cut away, but very carefully bent and tied back, so as to display the nest for photographing, and then allowed to resume their normal position. Although a nest containing eggs seems an easy subject to photograph, it requires very much thought and care to produce a really pleasing, artistic result. Young birds in the nest are by no means satisfactory, easy models. On no account must they be frightened or the nest disturbed, for both will lead to their untimely death; disturbing the nest frequently causes the parent to abandon them, or makes the young quit the nest too soon.

DISGUIISING THE CAMERA, ETC.

The photographer will find that some birds allow him to approach comparatively close to them, only taking wing when they catch sight of the camera; others, again, will show no alarm at the presence of the camera, but a very strong objection to the photographer. Frequently, the camera will have to be covered with boughs, moss, ferns, or rushes, to screen it from the sharp eyes of a nervous "sitter," while hours are spent waiting for its appearance. If the photographer has his subject really at heart—and he it said once and for all, he will never accomplish any successful results otherwise—he will never admit himself beaten or outwitted, but will always be ready to try some new device to attract his wayward model and set his fears at rest.

PHOTOGRAPHY OF REPTILES.

It is unfortunate that reptiles are still considered loathsome and horrible creatures by a large majority of people, for many snakes and lizards are most graceful creatures, extremely beautiful in coloration, and altogether most satisfactory models. Reptiles are in most cases not nearly so difficult to photograph as might generally be expected, and are really very interesting subjects. They are rather shy, nervous creatures, and therefore require careful attention, if satisfactory life studies are to be obtained. Lizards delight to bask in the warm sunshine, and very fine photographs showing them enjoying a sun bath can be fairly easily obtained. The resting lizard must however be approached with great caution, for a sudden noise or a shadow is quite sufficient to send it darting with lightning rapidity down some crack or cranny in the rocks. Snakes in the same way will dart away through the grass if disturbed, and the rapidity with which they travel when alarmed is astonishing and disconcerting to the photographer. Frogs and toads are particularly interesting and amusing for photographing, and are subjects which can be treated in quite a number of different ways. Very effective photographs showing how frogs, newts, etc., swim, can be obtained with the aid of a small aquarium. The outfit required for photographing reptiles is practically the same as that used for animal work. Many snakes and lizards are very beau-

tifully coloured, and therefore it is most desirable when photographing them to use orthochromatic plates, so that an approximately truthful rendering of the colours may be obtained.

PHOTOGRAPHING FISH.

Although not so interesting, perhaps, as animal and bird work, photographing fish has its own peculiar charms. Very little has been successfully accomplished in this branch of Natural History Photography up to the present time, so that it may be considered a somewhat neglected field. It is a difficult and trying branch of photography to take up, but the results when at last obtained are most charming. A long-focus reflex camera is the best type to employ, and it should be fitted with a very rapid lens and two shutters, a focal plane, and a pneumatic time and instantaneous shutter on the lens. Rapid orthochromatic plates are absolutely necessary for the best results, and frequently can be used without a filter, the water and glass of the aquarium acting as a colour screen.

THE AQUARIUM.

The most important part of the whole outfit for photographing fish is the aquarium in which they are to be placed for the operation. The size of the aquarium will largely depend upon the size of the fish it is proposed to photograph. The tyro will do well to content himself, for his first season at any rate, with only a moderate sized photographic aquarium, as the difficulties and troubles increase a hundredfold when it is larger. A small aquarium, say, about two feet long, will be found a very useful size to begin with, and will yield a very large number of most interesting pictures. It must be constructed of the very best plate glass, free from all imperfections, as any inequality or markings in the glass will show out in the photograph and quite mar the picture. The photographic aquarium must on no account be ever used as a stock or storage tank; it must be kept most scrupulously clean, being thoroughly washed out and freed from all dirt directly after use. One of the most troublesome factors the photographer has to fight in this branch of Natural History Photography is dirt. It is of vital importance, if the photograph is to

appear bright and sparkling, that the water of the aquarium shall be as clear and clean as possible.

PRECAUTIONS IN INTRODUCING PLANTS AND ROCKWORK.

At first sight it would seem a perfectly easy matter to beautify the aquarium by adding vegetation and stones to form a background to the picture; but this is by no means the case. The plants may have been collected from a running stream or taken from a clear, bright stock tank; but the moment they are placed in the photographic aquarium, no matter how carefully, they will be seen to give off a quantity of mud and scum. When a living and excited fish is introduced and promptly runs amuck among these plants that have been so carefully arranged, the results are truly disastrous, the mud and scum being thoroughly stirred up and distributed throughout the aquarium, making the water turbid, and photography an impossibility. All aquatic plants must be thoroughly cleansed, leaf by leaf, ere they are transferred to the photographic aquarium. Stones and rockwork must be well scrubbed, and on no account should fine sand be placed at the bottom of the aquarium, as the slightest movement of the fish will churn it up and thicken the water. So as to avoid the introduction of soil it is advisable to cut all plants off close to their roots, and to weigh them down to the bottom of the aquarium by fastening a strip of thin lead round the stems. By using narrow strips of lead or soft zinc, it is possible to clip the stems of rushes and reeds so that they will present quite a natural appearance, and the leaden weights can be hidden by placing a few stones and rocks in front.

WASHING THE FISH.

If possible, the fish itself should be gently washed before being placed in the aquarium, as it is sure to have a certain amount of dirt and scum attached to its scales; this is particularly the case with eels and other ground fish. Where the fish happens to be dangerous to handle, or, like the eels, covered with a slimy mucus, making it practically impossible to grasp it during washing operations, a certain amount of the sediment and scum can be got rid of by changing the water of the stock tank

several times, and, if possible, causing a jet of water to fall on the fish and keep it moving about, so that it washes itself automatically, before transferring it to the photographic aquarium.

NECESSITY OF PATIENCE.

The behaviour of fishes when first introduced into the photographic aquarium will be found to vary very greatly, hardly two subjects, even when of the same species, comporting themselves in exactly the same manner. In some cases the fish will become quiet and at home in its new surroundings in a very short time, and in others the photographer will have to wait for hours ere his unruly model will assume a natural pose.

BACKGROUNDS.

Artificial backgrounds can be used with advantage in the photographic aquarium, but they must be made as unobtrusive and natural as possible, and should be light grey to nearly white in colour. A sloping false bottom covered with white oilcloth or painted white will be found most useful for photographing ground fish, and also as a reflector to lighten the under side of fish which swim nearer the surface. With a little thought and care very beautiful effects of lighting can be obtained with the aid of the false bottom, two or three differently tinted backgrounds, and some white canvas screens to act as reflectors. The photographer should never be in a hurry to expose the plate, but be prepared to wait alertly for the moment to arrive when the fish of its own free will naturally assumes the characteristic and desired position.

PHOTOGRAPHY OF INSECTS.

A very wide and varied field of work is open to the photographer who is interested in insect life, for subjects are to be found in all situations and in every month of the year. If he only knows where to look he will find, even on the coldest and most miserable day in winter, some busy and interesting members of the insect world that will make good subjects for his camera; while during the spring and summer, and on into the golden autumn, subjects crowd upon him at every turn.

NECESSARY APPARATUS.

A good reflex camera is the best type to work with, as it enables one to focus up to the very instant of exposure. The camera should have a good extension of bellows, amply sufficient for the use of the back combination of an Anastigmat lens, and for low-power telephoto work. The lens should be a long focus one with a large working aperture. A low-power telephoto attachment will be found a most valuable adjunct, as it will enable the photographer to obtain satisfactory photographs of insects at rest, in situations where he could not approach sufficiently near to obtain a good-sized image on his focussing screen with the ordinary positive lens. The focal plane shutter will be found the best, as it allows the greatest amount of light to reach the plate in an extremely short exposure, which is of great importance, as many insects seek somewhat shady quarters, and are sufficiently restless to make an instantaneous exposure necessary. A good rigid tripod will be found very useful, both in the field and for work at home. Rapid orthochromatic plates are an absolute necessity, and should always be used for insect work.

PORTABLE BACKGROUNDS.

A most important and useful adjunct is a series of washable, differently tinted backgrounds. They should measure about three feet by two feet, and should be capable of rolling up into a convenient size for carrying in the field. These backgrounds will be found of the greatest service when photographing caterpillars feeding on trees or bushes. One of these backgrounds should be placed at the back of the branch or twig on which the caterpillar is feeding, when it will be found to not only do away with the confused blur of out-of-focus foliage which so often utterly spoils a picture, but will help to show up the caterpillar to advantage. In photographing spiders and their webs, a piece of black velvet will be found a most useful background, throwing up the delicate strands of the web into bright relief. Photographing insects on the wing, hovering over flowers, is particularly difficult, owing to the swift vibration of the wings, and should

only be attempted when the light is extremely good; with care and patience, however, very beautiful results may be obtained with the focal plane shutter.

SOME AVAILABLE SUBJECTS.

To trace with the aid of the camera the life history of a butterfly or moth, from the wee crawling larva just emerging from the egg, through all its wondrous transformations, until at last it bursts forth from out the old dry husk of its pupa case a glorious winged creature, will be found one of the most interesting and fascinating tasks the photographer can well set himself to accomplish. The aquatic larvæ of waterbeetles and the nymphs of the dragonflies can be collected, brought home, and photographed in an aquarium similar to that used for fish work.

PHOTOGRAPHING BEETLES.

Beetles are, generally speaking, somewhat troublesome and difficult to photograph really satisfactorily amongst their natural surroundings, for they are restless, easily frightened creatures, with but few exceptions, though a few, like the Devil's Coach-horse and male Stag Beetles, will stand up and show fight

when they find their retreat is cut off. The best plan is to capture the beetle and put him safely in a box, then focus the spot where he was found, place the dark slide in the camera, set the shutter, and when everything is ready for taking the photograph, turn the beetle loose from his prison on to the spot focussed, and when he arrives at the desired position release the shutter.

CONCLUDING REMARKS.

Insect work, though dealt with last, is by no means the least interesting or simplest branch of Natural History Photography, and calls for as much patience and resource as any other. It is undeniably capable of yielding most artistic and beautiful subjects for the camera, and will certainly provide a considerable amount of pleasure and instruction. In conclusion, it must be again insisted that the only royal road to success in any branch of Natural History Photography is patience, determination, resourcefulness in the presence of unexpected difficulties, and an inborn and real love for all living things. Some typical examples of Natural History Photography are shown in Plate 41.

TELEPHOTOGRAPHY.

EARLY HISTORY OF THE TELEPHOTO LENS.

THE parent of the modern telephoto lens was first worked out by Peter Barlow, and produced at a meeting of the Royal Society in 1834. It was known as the "Barlow" lens, and by its use the power of a telescope could be adjusted, by altering the position of the magnifying lens, without the necessity of removing the eye or losing sight of the object under observation. Telephotography, however, did not become a practical success until July, 1851, when the distinguished Italian scientist Porro obtained by means of the "Barlow" lens a successful astronomical photograph showing the eclipse of the sun. This admirable piece of pioneer work, like so much of the valuable experimental investigation carried out in the early days of photography, was soon forgotten, and so completely, that only within the last few years the celebrated optician Dr. Von Rohr re-announced the discovery of it.

WORK OF TRAILL TAYLOR, DALLMEYER, ETC.

Mr. J. Traill Taylor was probably the first to give any clear suggestion of the possibility of terrestrial telephotography, for in 1873, writing in "The British Journal of Photography," he suggests the use of an ordinary opera glass for producing an image on the ground glass screen, which would be larger, in proportion to the camera extension employed, than could be obtained with the usual type of positive lens. There was one great drawback to this, however, which necessitated the abandonment of the idea for some time, namely, that the opera-glass was, of course, uncorrected for photographic work. From 1873 until 1891 nothing of a really practical character came before the photographic world. Towards the close of 1891, however, Duboscq in France, Dr. Miethe in Germany,

and Thomas R. Dallmeyer in England applied for telephoto patents. In 1890 Steinheil constructed a telephoto apparatus for the German Government, but the fact unfortunately was not published until later. However, Mr. Thomas R. Dallmeyer was the first to place a practical telephoto lens in the hands of the photographer, the lens being shown and described by him in a paper read before the Camera Club, London, on December 10th, 1891. Since then, steady progress has been made in the improvement and perfection of the telephoto lens, the construction of which has of late advanced almost by leaps and bounds, until to-day we find it playing a very important part in both indoor and outdoor photography.

ADVANTAGES OF THE TELEPHOTO LENS.

By the use of a telephoto lens the photographer is enabled to obtain a magnified image of a distant object on the ground glass screen without an abnormally long extension of camera. To realise the importance and advantage of the telephoto lens, the two factors on which the size of the object focussed on the ground glass screen of the camera depends must be clearly grasped. Those two factors are, first, the distance of the object from the camera; and second, the equivalent focus of the lens employed to form the image on the focussing screen, the size of the object being in the exact ratio of the equivalent focus of the lens used. For example, any object rendered on the screen 2 inches high by a 10-inch lens will appear rendered 4 inches high by a lens of 20-inch focus. Now, supposing a lens of 10-inch focus is in use, and it is found that the size of the image on the screen is too small, while for one reason or another it is impossible to approach nearer to the object, the only remedy would be to use a

lens of longer focus. This would mean that a lens of 40-inch focus and a camera at least 40

inches long would have to be employed, supposing it was necessary to obtain an image on the plate four times as large as it would be if taken with a 10-inch lens. The disadvantages and costliness of such a method of obtaining an increase in the size of the object are most obvious, and it is these drawbacks which the telephoto lens overcomes. As an example of what can be done with a telephoto lens, a comparison of Figs. 864, 865, and 866 will be instructive. Fig. 864 shows a view of a distant building obtained with an ordinary lens; Fig. 865 was taken from the same standpoint with a low-power telephoto attachment; while Fig. 866 was secured with a higher power, this being, however, still a small degree of magnifi-

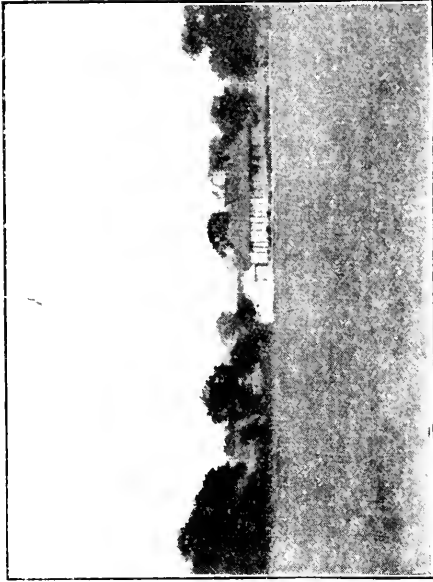

Fig. 865.—SAME VIEW WITH LOW POWER TELEPHOTO ATTACHMENT.

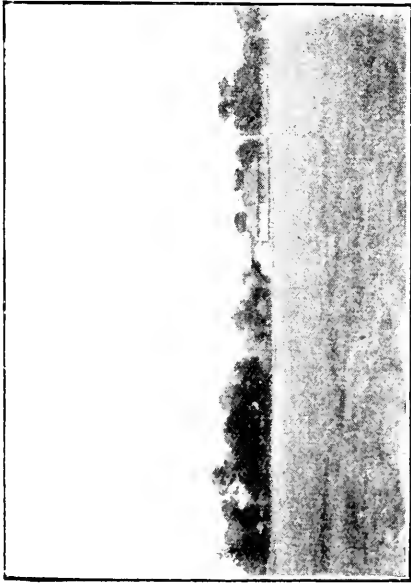

FIG. 864.—DISTANT VIEW TAKEN WITH ORDINARY LENS.

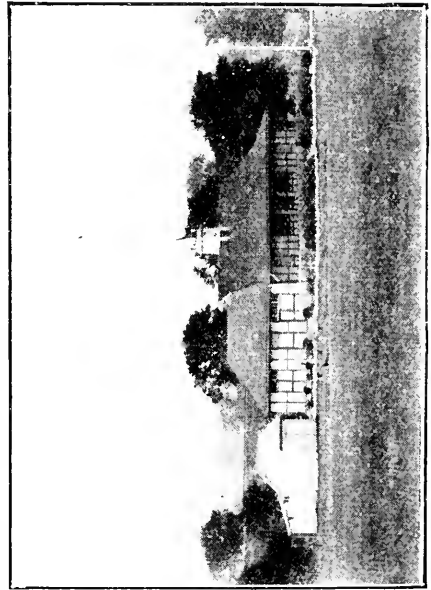

Fig. 866.—VIEW WITH MEDIUM POWER TELEPHOTO ATTACHMENT.

cation compared with what could actually be achieved if necessary.

GENERAL PRINCIPLES OF TELEPHOTO LENS.

The telephoto lens is essentially a long focus lens of peculiar construction, and as it is fitted with an adjustment whereby the focus can be varied at will, it may fairly claim to be not merely one long focus lens, but a series of long focus lenses. The principles which govern the construction of the telephoto lens are by no means difficult to grasp. If a card with a pinhole be substituted for the lens in a camera, and the ground glass carefully focussed, a position will be found where the image pro-

inches long would have to be employed, supposing it was necessary to obtain an image on the plate four times as large as it would be

jected by the pinhole is a facsimile on the same scale as that produced by the lens, only, of course, not so sharp or so brilliantly illuminated. It will be found that the position of the pinhole to produce this effect is in the plane occupied by the diaphragm of the ordinary doublet photographic lens: that is, in a plane corresponding to that occupied by the back optical node or projection centre of the lens. Now, although in the symmetrical form of lens the back equivalent or nodal plane is situated in the centre, or not far from the centre, of the lens, this is not by any means always the case; for in the primitive form of the uncorrected single lens its position will be found to vary with the curves of the surfaces. Thus, in a double convex lens, the optical centre lies in the middle of the lens: in a plano-convex lens, on the front surface: while in a meniscus lens

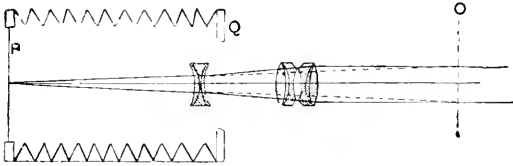

Fig. 867.—OPTICAL CENTRE OF TELEPHOTO LENS.

it is entirely outside the lens itself. It therefore stands to reason that if a double-convex and a meniscus lens, both of equivalent focus, be attached to two cameras, both will produce pictures on the ground glass screen, in which every object is identical in size, but owing to the different position of the optical centre in the two lenses, the length of the camera extension will be greater for the double-convex than for the meniscus lens.

POSITION OF OPTICAL CENTRE.

This marked effect of the position of the optical centre upon the camera extension forms a useful analogy when considering the telephoto lens, which is a combination of glasses designed so that its optical centre is a considerable distance in front of the lens itself. The accompanying diagram (Fig. 867), showing the position of the optical centre in the telephoto lens, will help to make this clear. Here *o* represents the plane of the optical centre, *p* the plane where the picture is formed upon the screen or plate, the distance *o p* therefore

being the equivalent focus: *q* is the plane in which the camera front lies, and *q p* shows the necessary camera extension to use a telephoto lens of a focus equal to *o p*. A camera extension equal to *o p* would be necessary to obtain the same result with an ordinary lens. Thus we see that the telephoto lens is a long focus lens, so constructed that only a short extension of camera is required.

THE NEGATIVE LENS.

A concave or negative lens is incapable of producing an image on the focussing screen of the camera, as it only possesses what is known as a virtual focus; but by combining a particular form with an ordinary type of positive lens, such as is used on the camera, a telephoto lens is produced. All ordinary photographic lenses are positive lenses capable of producing an actual or positive image; and any positive lens of good quality can be fitted with a negative lens (the telephoto attachment), the combination forming a complete telephoto lens. The duty of the negative lens is to take a certain portion of the picture produced by the positive lens and to magnify it. It is not at first easy to understand how a concave or negative lens, which causes objects to appear smaller, can be said to exert a magnifying influence. This may be explained, however, as due to the fact that while the rays of light on one side of the concave lens are converging, on the other side they are diverging, and it is this diverging or spreading of the rays belonging to the image formed by the positive lens which gives rise to the magnification.

VARIABLE FOCI.

The telephoto lens, as already stated, possesses the peculiar advantage of giving not only one focus, but many, and the means by which this property is obtained may be explained as follows: If a plano-convex and a plano-concave lens of the same kind of glass be placed in contact with each other, it is obvious that their action on light coming from a great distance will be practically the same as that of a parallel plate of glass. Their combined focus may be considered to be infinitely far away, and the plano-convex being a positive lens, and the plano-concave a negative, form a telephoto system with the longest imaginable focus. Now, should the two lenses be separated

by degrees the focus will be gradually shortened, until a point arrives when the plano-concave lens is in such a position that the light is brought by the plano-convex lens to its normal focus, and thus by varying the distance between the two lenses of the telephoto system the various foci are obtained. It will be seen, therefore, that the length of focus of the complete telephoto lens depends upon the degree of separation between its negative and positive components. The closer they approach each other, the longer the focus and the greater the magnification; while the further apart they are placed, the shorter becomes the focus, and the lesser the magnification, until the image altogether ceases to be enlarged. To find the magnification obtainable, divide the camera extension by the focal length of the negative lens and add 1; to find the necessary camera extension for any given magnification, multiply the focal length of the negative lens by the magnification, minus 1.

ANGLE OF VIEW.

When a telephoto lens is in use, the angle of view included in the circle of the field of view remains constant, and does not vary with the magnification. Altering the magnification increases or decreases the size of the circle of illumination, and the size of the picture only, but does not in any way alter the amount of the subject included in the whole field. It is very important for the tyro to bear this in mind, as when using a low magnification the entire surface of the ground glass screen will not be covered, but there will be a central circle of light representing the field of view, and darkened corners. By increasing the magnification, however, the diameter of the field of view will be enlarged until the whole surface is covered, though as the circle of illumination will then be greater than the diameter of the plate, the whole of the field will not be seen. Evidently, it is quite possible to increase the magnification to such an extent as to involve a danger of the surplus light being reflected from the interior surface of the bellows. This should be carefully avoided.

DIAMETER OF CIRCLE OF ILLUMINATION.

The following table, giving the diameters of the circle of illumination required to cover plates of various sizes, will be found useful.

CIRCLE OF VIEW REQUIRED, IN INCHES.	SIZE OF PLATE USED.
$5\frac{1}{10}$	$4\frac{1}{2} \times 3\frac{1}{4}$
$6\frac{1}{10}$	5×4
8	$6\frac{1}{2} \times 4\frac{3}{4}$
$8\frac{4}{10}$	7×5
$10\frac{7}{10}$	$8\frac{1}{2} \times 6\frac{1}{2}$
$12\frac{3}{4}$	10×8
$15\frac{1}{2}$	12×10

EQUALITY OF ILLUMINATION.

Owing to the distance apart of the lenses of the telephoto system, the intensity of the illumination decreases somewhat towards the edges of the field; it is, therefore, most important to use the telephoto attachment with a good rapid positive lens of the modern anastigmatic type, while the use of a positive lens designed only to cover the plate for which it is constructed should be avoided. As any increase in the equality of illumination in telephoto work has to be obtained by stopping down the positive, the value of the modern anastigmat, with its perfection of corrections, large working aperture, and brilliancy and equality of illumination, is obvious.

LENS APERTURE, AND HOW FOUND.

The conversion of the ordinary positive photographic lens, by the addition of a telephoto attachment, into a telephoto lens, though altering the focus of the lens, does not affect the size of the aperture; so that the increase of focal length reduces the rapidity of the lens, so long as the iris diaphragm remains.

The standard apertures and relative exposures with the ordinary positive photographic lens are as follows:—

APERTURE.	RELATIVE EXPOSURE.	APERTURE.	RELATIVE EXPOSURE.
$f/4$	1	$f/22.6$	32
$f/5.6$	2	$f/32$	64
$f/8$	4	$f/45$	128
$f/11.3$	8	$f/64$	256
$f/16$	16	$f/90$	512

Therefore, to find the effective aperture or rapidity of the telephoto lens in terms of the focus (f), the aperture fraction of the positive should be divided by the magnification in

use, or, what is the same thing, the denominator may be multiplied by the magnification. If the positive is working at an aperture of $f/8$, and a magnification of 4 is to be employed, the aperture of the whole system in terms of

aperture of the positive lens is not less than $\frac{1}{4}$ in. in diameter when stopped down, this rule may be safely ignored, no matter how small the fraction representing the focal value may be.

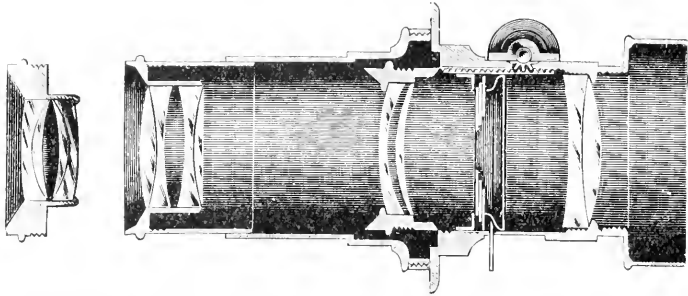

Fig. 868.—DALLMEYER'S MODERATE-POWER TELEPHOTO LENS, WITH HIGH-POWER ATTACHMENT.

TELEPHOTO ATTACHMENTS.

To meet a steadily growing demand, the principal lens makers are now nearly all making telephoto attachments to suit their positive photographic lenses. The old established firm of Dallmeyer has done much to advance and popularise telephotography, and no treatise on the subject would be complete without mention of their unique "Adon" telephoto lens, which, with other useful objectives for this class of work, is described in the section on Lenses. Fig. 868 shows Dallmeyer's Moderate-power Telephoto lens, which is provided with an interchangeable High-power Negative Attachment. The

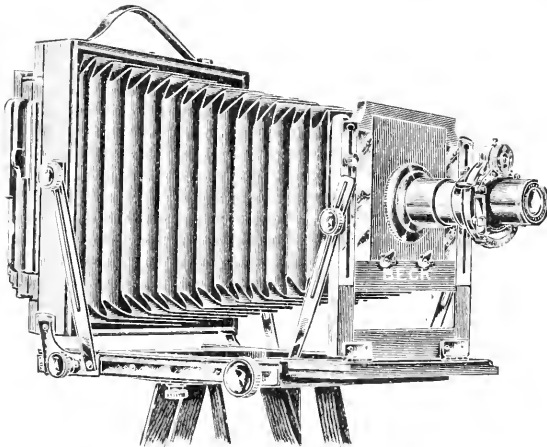

Fig. 869.—CAMERA WITH BECK "MULTIFLEX" LENS.

the focus will be $f/32$, and therefore, if an exposure of four seconds was required with the positive lens alone, sixty-four seconds will have to be given for the telephoto lens.

STOPPING DOWN.

Although the equality of illumination and depth of focus in the telephoto lens is improved by stopping down the positive, great caution must be observed in the closing of the aperture, as should the aperture be much smaller than $\frac{1}{2}$ of its focal length ($f/72$), diffraction takes place, spoiling the sharpness of definition in the picture. Where, however, the actual

Beck-Steinheil series of Low, Standard, and High-power Telephoto Attachments call for special mention on account of their great perfection, the wide field of application which they render possible, and the excellent work which has been accomplished with their use. The Beck "Multiflex" lens, shown in position by Fig. 869, has a focussing mount and gives also available for ordinary work. The very latest advance in telephoto lenses is a low-power attachment by Goerz, specially designed for subjects requiring the shortest possible exposure. This is especially useful for Natural History photography and similar work, or for securing street scenes, processions, etc., from a moderate distance, when the light permits.

INSTANTANEOUS TELEPHOTOGRAPHY.

With the great improvements in lens construction which have been made during the last few years it is now possible, by using a positive lens giving great equality of illumination combined with rapidity, and a low power element and magnification only, to practise instantaneous telephotography, the exposure in bright sunlight ranging from $\frac{1}{100}$ to $\frac{1}{16}$ of a second, according to the magnification employed. Great attention is being given by the leading manufacturers of photographic lenses to the possibility of further increasing the rapidity of the telephoto lens, as the demand for such an instrument is steadily growing.

SELECTION OF APPARATUS.

Although telephotography can be practised with any camera having a fair extension of bellows, the ordinary stand camera does not generally lend itself to the production of the best possible results, as the tendency in most modern cameras is to obtain great lightness and portability at the expense of rigidity. In selecting the camera that is to be used for telephoto work it is of vital importance that it should possess great rigidity when racked out to its fullest extension. Vibration is the deadliest enemy the telephotographer has to contend with, and therefore, if the best work is to be accomplished, it is of the greatest importance that the camera be specially rigid, that the tripod head be large and solid, and the tripod stoutly built. The camera, besides being well made, should have a long extension of bellows (the length of bellows governing the amount of magnification possible), and the bellows should be square for preference. Considerable rising front and swing-back are also most desirable features. The tripod should be stoutly built and thoroughly rigid, with a broad, firm head to counteract any tendency to springiness. A strut, which can be attached between the front extremity of the camera base and a leg of the tripod, is a most useful and necessary adjunct, as it will be found to impart greatly increased rigidity when a long extension of bellows is being used. Another good form of support is shown by Fig. 870.

CONSTRUCTING SIMPLE TELEPHOTO LENS.

With the aid of a circular, concave spectacle lens, which may be obtained from any optician

for a couple of shillings, a serviceable telephoto attachment may be made for use with any ordinary photographic lens, a rapid rectilinear being the best for the purpose. A short tube of cardboard is fashioned, of a length to be found by previous experiment with temporary

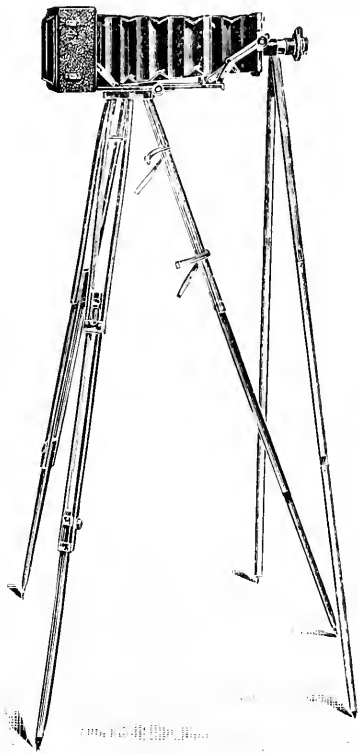

Fig. 870.—SUPPORT FOR TELEPHOTO LENS.

paper tubes, to exactly fit the back of the R.R. lens. Another tube is made, over which the first should slide easily but not loosely, and at the end of this second tube is glued the spectacle lens. A wooden or cardboard panel should be cut to fit the camera front, having a circular hole for the cardboard tube, and to this the tube carrying the spectacle lens is glued, the latter being nearest to the bellows. Before gluing on, both tubes are well blackened and care taken that there is no leakage of light. The tube carrying the positive or R.R. lens is slid along the other tube to obtain different degrees of magnification, and should be provided with a velvet rim at the outside end to

fit the R.R. lens, so that the latter may be removed when desired. As the spectacle lens is non-achromatic, it may be necessary to allow a slight correction by racking the screen slightly forward after focussing; this can only be ascertained by experiment. Although, of course, not of the highest grade, very good work can, on occasion, be done with this simple apparatus.

APPLICATIONS OF TELEPHOTOGRAPHY.

Telephotography is capable of many applications. In natural history work it is of very great importance, making it possible to obtain photographs of the most timid and shy creatures. For photographing birds and their nests it is invaluable; and, as much better perspective is obtainable with the telephoto lens than the ordinary positive photographic lens, the nests appear far more natural when telephotographed. In architectural work the value of telephotography cannot be over estimated, as it becomes possible to obtain photographs of delicate ornamentation, carving, gargoyles, etc., which were formerly entirely unapproachable, or only to be obtained with the aid of elaborate scaffolding. For medical purposes telephotography has its uses, particularly when it is desirable that the camera should not be in the vicinity of the patient. Singularly soft and delicate portraits may be obtained with a low-power telephoto attachment, giving a very pleasing effect and most artistic perspective. In time of war, the telephoto

lens has proved invaluable for obtaining photographs of distant fortifications, and it is also useful for balloon work. In fact, for any subject that is too far off to be photographed with the ordinary positive lens, the telephoto lens can be successfully employed. In landscape work the use of the telephoto lens is a very great advantage, and productive of most artistic results, as the perspective obtained is much more pleasing to the eye than that given by the ordinary positive lens.

CONCLUDING REMARKS.

Mist and haze are the great foes of successful telephotographic work and are not always easy to detect. An isochromatic screen to cut off only the ultra violet and violet-blue rays, without reducing the brilliancy of the rest of the spectrum, will often enable a slight haze to be ignored. Vibration or shimmering of the atmosphere is another obstacle, difficult to overcome if present; while the presence of wind is, of course, highly objectionable. If difficulty is found in focussing, a microscopic cover-glass may be attached with Canada balsam to the ground side of the screen. This will give an almost clear spot, on which a small portion of the image may be readily examined by the aid of a focussing magnifier. Unnecessary magnification should be avoided, a good rule being to start with a low power and gradually raise this until the result is considered satisfactory.

PHOTO-CERAMICS.

INTRODUCTORY REMARKS.

CERAMIC PHOTOGRAPHY is the art of obtaining a burnt-in impression of any picture produced by photographic means on earthenware or porcelain tiles or medallions. It can obviously be also applied to the decoration of any china utensil, whether for use or ornament. Photographic pictures of this description are the most permanent that can possibly be obtained, since the image, formed by a vitriifiable powder, is protected by a practically imperishable glaze. Owing possibly to a mistaken idea of its difficulty, the art is comparatively little practised, although the results obtainable are of the greatest beauty. Ceramic enamels, however, consisting of vitrified photographs burnt into enamelled copper plaques, have been made for many years by Morgan and Kidd, of Richmond, and have lately become rather more popular.

DIFFERENT METHODS OF WORKING.

It will be readily understood that the thin silver image of an ordinary photographic print would be quite unsuitable for this description of work, on account of the high degree of heat it will have to endure while being fired. The material of which the picture is composed must obviously be of a special nature. In the dusting-on, or powder process, a bichromated film of various sticky or tacky substances loses its tackiness in different degrees by exposure to light under a negative, so that on brushing the prepared plate over with a suitable powder a reproduction of the transparency is obtained. Now, if for the ordinary

powder used in this process a powdered vitriifiable colour is employed, the method immediately becomes applicable for ceramic purposes, since the picture will then stand firing without injury. This is, in fact, the process chiefly in use. Another method, which is very similar, depends upon the fact that iron chloride, though not of itself adhesive, becomes so by exposure to light. A third method is very like the carbon process, enamel colours being substituted for the ordinary pigments, and a mixture of gum and honey for the gelatine. Fourthly, there is the substitution process, in which a silver image obtained in the ordinary manner is converted into platinum or iridium by chemical substitution, the latter metals being well adapted to stand extreme heat. In addition to these, there are one or two other methods of less importance, which will, however, be touched upon in due course.

THE DUSTING-ON PROCESS.

This process, as applied to ordinary photographic printing, has already been described in detail (see pp. 201—204). It is recommended that the pages mentioned be first well studied. It will then be possible to grasp clearly the slightly different manner in which the dusting-on process is adapted for photo-ceramic purposes, as will now be explained. It will be seen, to begin with, that a transparency is required, since the picture obtained is an exact replica of the plate printed from. This also suggests that, for good results, a bright, clear transparency, vigorous, and of the highest quality, is necessary. Messrs. Morgan

and Kidd use a soft transparency and a weaker sensitiser. If vignetting is required, this must be done in making the transparency, for it will be impossible afterwards. Collodion or photo-mechanical plates will produce the best effects.

PREPARING THE PLATE.

The image for firing is not produced at first on its final support. Thin plates of patent plate glass are employed, the picture obtained on these being afterwards coated with collodion, stripped and transferred. The glass plate is well cleaned, care being taken that it is absolutely free from dust. The coating operation is described on p. 203, and it is consequently only necessary to remark that the heat used in drying should not be greater than can comfortably be borne by the back of the hand. If much work is to be done, a whirler (see Fig. 389, p. 271) is useful for rapid drying. A special pattern is obtainable for use over a gas jet. A thin, even coating should be aimed at, and the film, if properly prepared, will be quite glossy when dry. Some of the formulæ given on p. 203 will prove suitable, but the following is recommended as peculiarly adapted to the work in hand. It is best kept in two solutions, equal parts of each being mixed together and filtered as required. These solutions are known respectively as the organifier and the sensitiser.

THE ORGANIFIER.

Le Page's Fish Glue	1 oz.
Glucose	4 oz.
Glycerine	10 minims.
Water	10½ oz.

THE SENSITISER.

Ammonium Bichromate	7½ drs.
Water	10½ oz.

These solutions, or very similar ones, may be purchased ready prepared for photo-ceramic work.

EXPOSURE AND DEVELOPMENT.

The requisite exposure will, of course, vary with the transparency and the light.

If an actinometer is used, as advised on p. 203, the correct duration will soon be found. As a rule, for this kind of work it will be anything from about 40 seconds to 3 minutes in the sun, to about 15 minutes in diffused light. With a correct exposure the image will be faintly visible on the film. Development is performed as directed on p. 204, except that it is recommended to hold the plate in an inclined position resting on a sheet of white paper, sensitive side towards the light, so that progress may be viewed by both transmitted and reflected light. A subdued white light should be used. An important difference which here comes into play is that instead of ordinary powder colours a vitrifiable ceramic powder must be employed.

THE VITRIFIABLE COLOURS

These colours consist of certain metallic oxides and other fusible ingredients. They are obtainable in various tints and combinations from artists' colourmen or dealers in photo-ceramic materials. The powder should be sufficiently fine as purchased; if there is any doubt of this, however, it may be re-ground with water on a glass slab, using a muller for the purpose. A portion may be done at a time, about ten minutes' grinding being sufficient. The powder is then thoroughly dried and passed through a fine silken sieve. Dust must again be carefully avoided. Different colours may be blended by well grinding together in the same manner. Ceramic colours do not in all cases remain the same tint after firing, and different degrees of heat sometimes produce varied results. This is a matter in which experience only will prove a reliable guide.

MAKING BLACK ENAMEL COLOUR.

As a rule, it is hardly worth while to attempt the manufacture of ceramic colours, but for the benefit of those who may wish to do so, or find any difficulty in procuring them, the following recipe for a good black is given. First prepare

what is called a flux, consisting in this case of

Silica	2 drs.	(Avr.)
Minium	1 oz.
Borax	$\frac{1}{4}$ oz.

Thoroughly mix and melt the ingredients in a crucible at a high temperature, stir well with an iron rod, and pour the fused mass on a metal plate. When cold, well pound in a mortar with a pestle, and reduce finer on a glass slab with the muller, and pass through the silk sieve previously mentioned, which may be obtained from dealers in photo-ceramic materials. The black enamel pigment is compounded of

Black Iron Oxide (Fe ₃ O ₄)	$\frac{1}{4}$ oz.
Flux	$\frac{1}{2}$ to $\frac{3}{4}$ oz.

COATING WITH COLLODION.

If perfectly flat plaques or tiles are used, the powder image may be obtained direct on the final support ; it is, however, generally preferable to use a temporary glass plate as described, afterwards coating the picture with collodion, stripping and transferring. The image should, if properly developed, possess about the same vigour and transparency as a good lantern slide. When this is attained the surplus powder is dusted off, and the picture coated with plain collodion, not too thick in character. A collodion specially made for the purpose is commercially procurable. It is flowed over the plate like a varnish, as described on p. 81. When the collodion has set, a sharp penknife is pressed downward through the edges of the film on three sides of the plate, cutting through to the glass ; the plate is then immersed in several changes of water, preferably filtered, to remove the bichromate salt. The film will separate from the plate, except on one side, and this will facilitate washing. When the bichromate seems nearly all removed, the film is placed in a solution of fused borax for about ten minutes, finally washing in a fresh bath of filtered water for an equal period. Care and gentle handling are necessary throughout.

PREPARING THE BORAX SOLUTION.

The borax solution mentioned, which is also used in the operation of transferring and for other purposes, requires special preparation, since fused borax is almost insoluble in cold water. The best plan is to pulverise a couple of ounces and boil it rapidly in an enamelled saucepan, stirring continuously. After about four or five minutes' boiling, decant the solution and add fresh water, repeating this till all the borax is dissolved. For use, when cold, take 3 parts of this saturated solution to 1 part of water.

TRANSFERRING.

For this purpose a large basin or dish should be used, filled with the above borax solution. The plate, after its final washing, is stood in a rack for a few minutes to drain off the surplus moisture. The penknife is then very carefully passed along the fourth edge of the film, cutting through it by means of a series of pressures, not by drawing the blade along, for the latter method would pucker or tear the moist film. The plate is now placed in the basin, and the film will float off the glass, which can then be withdrawn. Using a moderately large camel-hair brush, turn the film over in the solution so that the collodion side is downward. Great caution must be used not to damage the loose film or abrade the powdered side, and the fingers should on no account be employed. The plaque or other support is next carefully introduced under the floating film, which is guided into its correct final position. The support is then slowly, and by degrees, lifted out of the water with the film adhering. The powder side of the latter, as before stated, must be uppermost. If the dish is small, it may be as well to place the plaque ready in position before floating off the film, using a small china block, or anything else found suitable, to raise it from the bottom, since if this is not done it may be awkward to move it when required. When the support is withdrawn, with the film satisfactorily attached, it should be placed on a few sheets of

blotting paper to dry, on a level surface. When dry, any loose pieces of film which have strayed over the back or margins may be removed with a damp sponge.

PREPARATIONS FOR FIRING.

If all has been correctly done, the image should now appear on the plaque in a similar position to that which it occupied on the transparency. It should be very carefully examined for any black spots or other imperfections. The former may be removed with a fine needle point set in a wooden handle. In order to form a temporary protective coating for the delicate powder image the following mixture is flowed over it:—

Fat Essence	10 minims.
Oil of Turpentine	1 oz.

Fat essence is any essential oil, oil of turpentine being, perhaps, the most suitable, which has been allowed to evaporate to a fatty consistency under the prolonged action of light and air. The mixture, made as above, should be filtered and kept from the dust. When dry the plaque coated with this medium should appear uniformly dull. Any white spots on the picture may now be filled in with a little of the powder colour mixed with turpentine and fat essence. A preferable way to prepare the image for spotting is to give the plaque a light firing, just sufficient to attach the powder to the surface. The print can then be spotted or worked upon with facility. The plaque is now ready for firing. Before proceeding to describe the latter process, however, it will be more convenient to consider in turn the various other methods by which an image in ceramic colours may be obtained.

THE IRON PROCESS.

Instead of using the dusting-on process, a film prepared with iron chloride may be employed. This salt, as before stated, has the property of becoming tacky by exposure to light. It is, therefore, only necessary to expose such a film under a negative to obtain a plate of various

degrees of tackiness, which is then developed by brushing over with powdered enamel colour as before. An obvious advantage of this method is that no transparency is required. The picture so obtained is coated with collodion, stripped, and treated in just the same manner as previously described.

ADAPTATION OF THE CARBON PROCESS.

Prints obtained by the carbon process, simply substituting enamel colours in the preparation of the film, instead of the usual pigments, may be developed upon porcelain as a final support, forming excellent pictures for firing. Gelatine, however, though it may be used, is liable to introduce complications when firing; a mixture of honey and gum is therefore preferred. The latter ingredients are well mixed with the powder and the bichromate solution added; the sensitised compound is then flowed over the plates and allowed to dry. A negative is used for printing, as in the carbon process, the exposure being ascertained by an actinometer. The film is then coated with collodion and soaked in water for a short time. Next the plate is removed from the water and covered with a sheet of moistened paper, which is well squeezed down. The film can now be removed from the plate and developed on the temporary paper support, using warm water. When development is complete, the film is soaked in several changes of water to remove the bichromate, and transferred to its final porcelain or earthenware support. When dry, and before firing, the collodion film may be removed by gently rubbing with a soft rag dipped in acetic ether.

USING PHOTO-MECHANICAL IMPRESSION.

Another method, useful where numbers are required, is to obtain a photo-mechanical impression in the usual manner on a special transfer paper prepared with a collodion substratum. A suitably tacky ink must be used for printing, and the ceramic powder is dusted over this. The paper is then moistened and re-



Negatives by Baedon Bros., 160, Buckingham Palace Road, S.W. Taken with Voigtlander's Collinear Lens, Series II.

EXAMPLES OF INSTANTANEOUS PHOTOGRAPHY.

moved, while the film and picture, collodion side downwards, are transferred to the porcelain support or plaque, which is first treated with an adhesive medium. A variation of this is to prepare paper, thin metal, or celluloid, for the reception of a collodion film, so that it will strip when desired, but not too readily. The material is coated with collodion, and, when dry, the photo-mechanical print is obtained on the latter surface, using for ink a medium charged with very fine ceramic colour, or such a pigment as iridium black. The collodion film is then stripped from its temporary support and transferred with the image to porcelain for burning in.

THE SUBSTITUTION PROCESS.

There are various modifications of this process, but the following procedure may be taken as representative. A collodion positive is obtained in the camera by the wet process, taking care to secure a clear, vigorous image. After fixing and washing, the plate is thoroughly bleached in a 5 per cent. solution of mercuric chloride. When this is accomplished, the plate is again washed and placed in the substitution bath, which is to replace the original image, unsuitable for firing, with one of platinum or iridium. A picture of an excellent purple-brown colour is obtained by using a gold and platinum bath, as given below:—

Potassium Chloro-platinite	8 grs.
Gold Chloride (1 in 60)	4½ drs.
Water (distilled)	4½ oz.
Lactic Acid	5 minims.

Or a warm black tone is secured by the following iridium and gold bath:—

Iridium Chloride	8 grs.
Gold Chloride (1 in 60)	4½ drs.
Water (distilled)	4½ oz.
Lactic Acid	6 minims.

When the deepest shadows of the picture are toned through, wash for a few minutes to remove the free toning solution. Now very carefully cut round the margins of

the film and immerse the plate in a 1 per cent. solution of sulphuric acid. Presently the film will strip off, when it is cautiously washed, transferred to the final support of porcelain or other material, collodion side up, and dried. When dry, remove the collodion film by gently rubbing with a sponge moistened with ether and alcohol. Again allow to dry, and dust the image with flux, when it is ready for firing.

THREE-COLOUR PHOTO-CERAMICS

It is quite possible to obtain a burnt-in picture in natural colours by the exact superposition of a blue, a red, and a yellow picture printed from three negatives obtained through suitable screens, as described in the section on "Photography in Colours." The powder process appears to be the most suitable for this purpose, although the photo-mechanical method may be used. The yellow film is first transferred and fired; this is then allowed to cool, and the blue image very carefully superposed on this in exact register and burnt in. After again cooling, the red film is finally transferred and fired, when the tricolour ceramic picture is complete. The greatest attention must be paid to securing colours properly adapted to rendering their individual portion of the picture while combining well with each other. Transparency and depth are especially necessary. A certain amount of retouching will be required at each stage, though as little as possible should be done. The introduction of colour effects, it goes without saying, renders the whole process far more difficult

COMBINATION EFFECTS.

A good deal of scope will be found for the production of artistic effects by a judicious use of tinted grounds, fired before the image proper is laid on. A method known as "colouring behind" may be sometimes used to advantage. This consists of obtaining a faint print in a warm colour to act as a ground, and, after firing this, to roughly tint in the desired final colours, using, of course,

enamel powders. This must be done rather deeper than it is desired to be when finished, somewhat after the fashion of the back tinting in a crystoleum picture, taking care to leave the high lights untouched. This roughly-coloured picture is now fired, and, when cool, the final transfer, which is to supply the definite outline and shading, is applied. A suitable tint for this is a rich sepia, or any other dark brown; black will hardly look so well. Care should be taken to obtain a good glaze in the last firing. If it is desired at any stage to remove small portions of colour in the lights after firing, this is readily done by applying a dilute solution of hydrofluoric acid to the intended part with a fine camel-hair brush, immediately placing under the tap. It is better to do this gradually, with repeated washings, than run the risk of taking off too much colour at once.

PAINTED ENAMELS.

Photo-enamels are frequently set in as pendants, locket, panels in caskets, or on backs of watches, and there is no form of photograph more suited to such purposes. It is, however, often considered that a monochrome picture is not sufficiently decorative for an elaborate setting, and this objection may be met by painting the enamel in colours. Very beautiful results may be obtained by artistic treatment, as the photographic image is to a large extent burnt away during the successive firings necessary to the painting, leaving pure, clean colouring, undegraded by the photograph underneath. Soft enamel colours similar to those employed for dusting on should be used. They may be obtained in powder in all tints from makers of ceramic colours. The best medium for mixing the colours is oil of lavender, to which may be added a little fat oil of turps, which will cause the colour to adhere to the plaque more readily. Powder and mediums are mixed with a palette knife to a consistency convenient for use with a sable brush of the kind generally used for water-colour painting. The image to be painted may be of usual

depth and quality, and it should have been fired lightly on to the plaque, but only sufficient to prevent the powder from moving. It requires no other preparation for painting, and the colouring should be proceeded with in the same manner as in painting a miniature on ivory or in tinting an ordinary photograph. It is, however, advantageous to lightly fire the colouring of the heavier shadows before proceeding with lighter tints. By firing lightly two or three times at convenient stages during the progress of the work, it can be so arranged as to give more firing to the heavily painted parts and less to colours which do not stand heavy firing, or are put on in light tints and therefore do not require so much heat to glaze. The chief firing should be left till the completion of the work, and should be sufficient to fully glaze the whole surface. After firing, some enamel colours change somewhat in tint or intensity, and allowance must be made for this when painting. Such change may give trouble and confuse a novice, but it offers little difficulty to the experienced artist.

DIFFERENT METHODS OF FIRING.

There is a common impression that photo-ceramic work cannot be undertaken without the possession of a furnace for firing. This is a mistake, for the tiles, plaques, etc., will be fired for the worker at any pottery for a moderate charge. Far more experience will, however, be gained, and greater interest aroused, if the worker does his own firing, and this is strongly recommended if any amount of ceramic work is to be done.

GAS FURNACES.

Gas is the most convenient fuel where it can be obtained. The gas muffle furnace shown by Fig. 871, made by Fletcher, Russell and Co., Ltd., is well recommended. The furnace itself is of fireclay bound with iron bands, the chimney and burner being detachable. A section of the arrangement is shown by Fig. 872. The thin fireclay muffles are very liable

to crack. They may, however, as a rule, be readily repaired with a moist paste of fireclay, a supply of which should be kept for luting the muffle into place, so that no fumes of gas may escape into the interior, as this would be detrimental to ceramic colours. Fortunately muffles are not expensive, and are easily replaced when broken; a spare one or two should be retained in case of accident.

DIRECTIONS FOR USING GAS FURNACES.

The following directions are given by the manufacturers for working these furnaces: A large unobstructed supply pipe

gas is unobtainable, the furnace may be worked at a lower heat by partially closing the top of the chimney until the flame becomes visible, or by working without the chimney. Should the burner plate become red hot, the gas supply is deficient. The points of blue flame should be visible on looking sideways into the burner. To light the burner, insert a lighted taper through the burner casing, up between the grooves in the burner plate, and slowly turn on the gas. On no account turn the gas on before applying

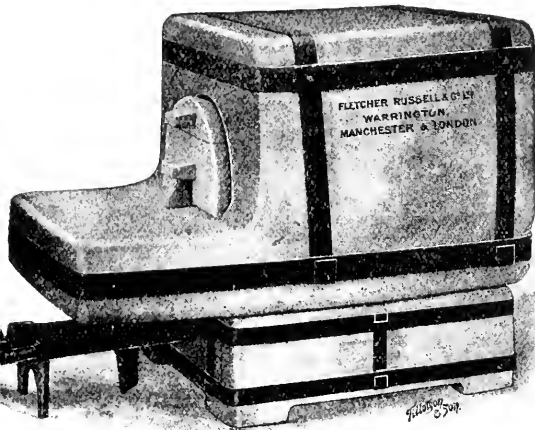

Fig. 871.—Gas Muffle Furnace.

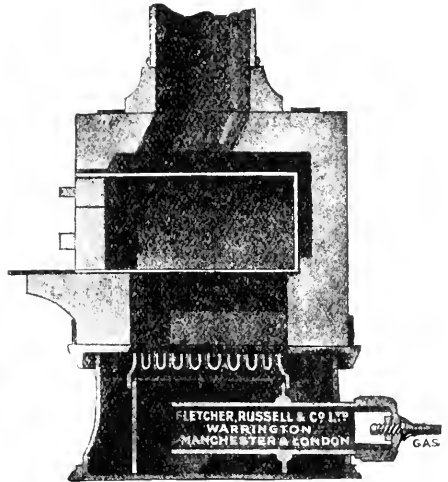

Fig. 872.—INTERNAL ARRANGEMENT OF GAS MUFFLE FURNACE.

and tap must be used, so that the greatest pressure possible may be obtained. The actual amount of gas consumed is, however, small. The rubber tubing must be absolutely smooth inside; tubing made on wire will not work the burners satisfactorily, even if the wire is taken out. Muffle furnaces of this pattern are sent out with a 2-ft. 6-in. chimney, having a short handle for lifting and a cast-iron foot to steady it. A height of 6 or 9 in. is, however, quite sufficient for photo-ceramic work, so that the chimney may be cut shorter. A definite gas supply is specified with each furnace, and this is necessary for working the latter at full power. The flame should be visible in the chimney. Where the full supply of

the taper, or a severe explosion may result. If the furnace is hot, and it is required to relight it, it may be necessary to cover the air opening round the gas entrance, to prevent the flame descending through the gauze at the moment of lighting. The burners must be kept clean, for which purpose they are made to take apart.

IMPROVED MUFFLE FURNACES.

A perfected series of muffle furnaces are made by Fletcher, Russell and Co., Ltd., which allow a greater precision of temperature and a more delicate adjustment than the older patterns. Fig. 873 shows a typical example of these. A pressure

governor is recommended on the gas supply to secure absolute exactness of temperature, and a Quadrant gas tap will be found extremely useful for regulation purposes. Most of the muffle furnaces supplied by this firm can be obtained to work with petroleum oil, gasoline, coal gas and oxygen, air, water, and Dowson or producer gas if desired. In using these furnaces, the whole of the taps should be

the whole left to cool. The delay of waiting till the first firing has cooled before any more work can be done may be avoided by having an annealing chamber, or hot closet, in which the fired plaques may be placed to cool gradually. These resemble a sheet-iron oven with shelves, and are supported over a gas-heating ring. When tiles are being fired the oven is heated up, and a liberal

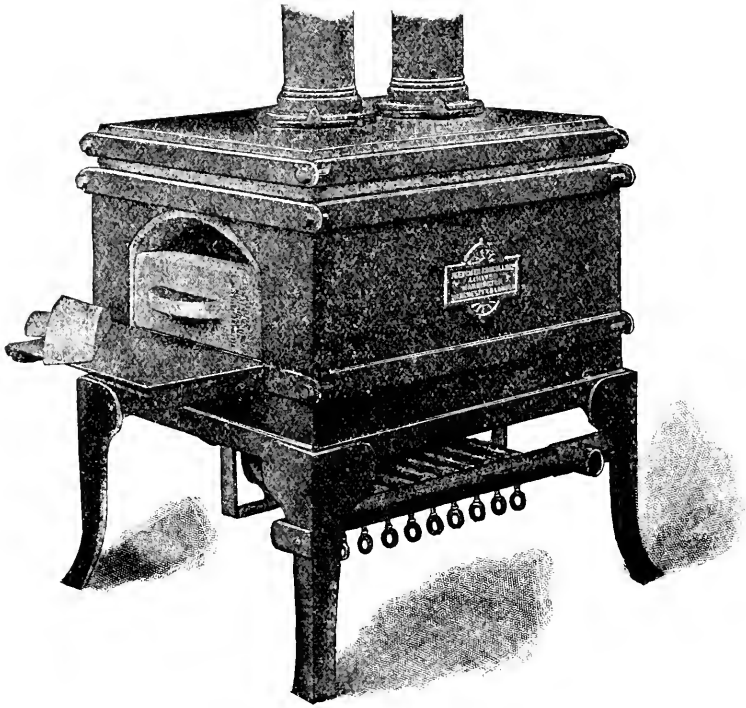

Fig. 873.—IMPROVED MUFFLE FURNACE.

turned off and each burner lighted in succession, or the burners may ignite at the jet.

THE OPERATION OF FIRING.

For tiles and plaques the heat must be applied very gradually, or they may crack. This is done by starting with the burners turned low, and gradually increasing the consumption of gas. When the furnace is fully heated, the gas is immediately turned out, the chimney covered up, and

amount of coarse sand warmed inside it at the same time. On the completion of the firing, the tile is quickly withdrawn, using a long crucible tongs for the purpose, sprinkled with hot sand, and laid on one of the shelves in the annealing oven. The gas in the latter may now be turned out, unless there are more plaques to come. Draughts should be carefully avoided in transferring from the furnace to the annealing chamber, and the door of the latter should be kept closed, opening only to admit work. Some

patterns of glass-painters' furnaces are provided with an annealing chamber on top to utilise surplus heat, but these are, of course, more expensive. Such an arrangement is shown by Fig. 874.

useless, but the metal support will be fused. Wait till the muffle is nearly red-hot, then insert a ring of fireclay, and, when this is as hot as the muffle, place on it a thin slab of fireclay. When the

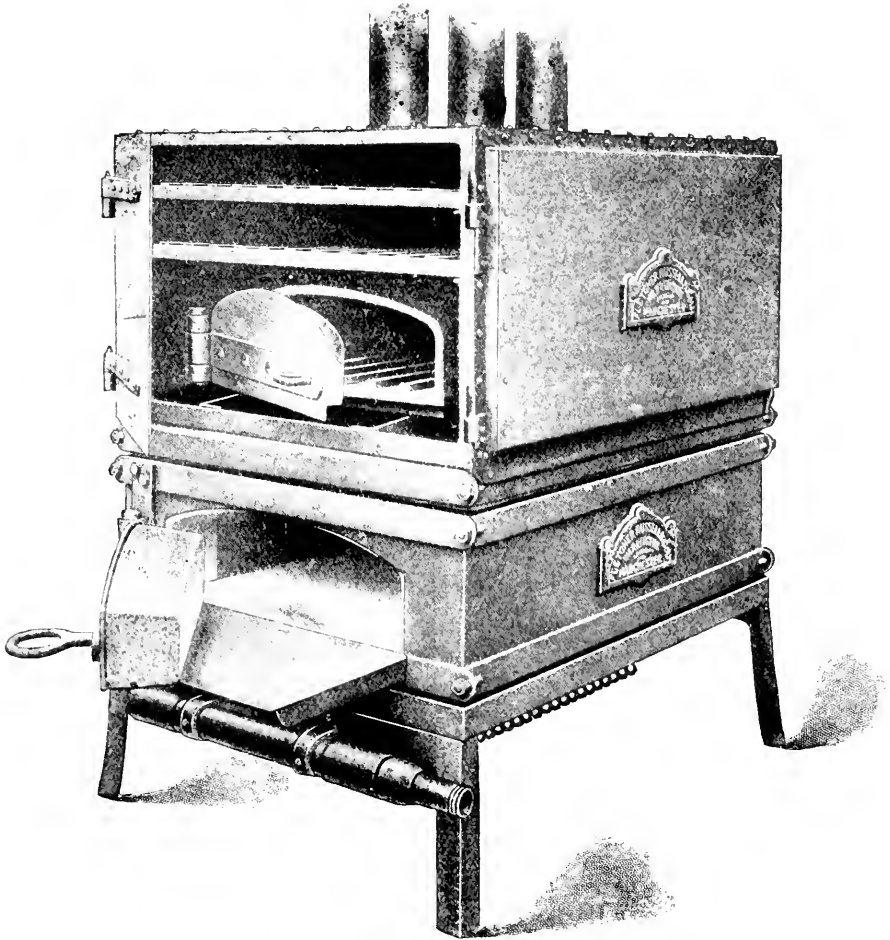

Fig. 874.—GLASS-PAINTER'S FURNACE WITH ANNEALING CHAMBER.

FIRING ENAMEL PLAQUES.

Enamel plaques or medallions on a metal base need not be cooled with such extreme care. The heat required is that known as a red heat. Care should be taken not to use the full possible power of the furnace, or not only will the ceramic picture be burnt and rendered

muffle has become a dull red draw out the fireclay slab with the crucible tongs, and place the enamel plaque upon it. Keep both slab and plaque just outside the furnace door, turning them round occasionally until the film of the plaque becomes a deep brown tint. When this takes place, push the slab and plaque into the centre of the muffle and close the

door. After about three minutes, take off the top half of the door and turn the fireclay support with the crucible tongs. The picture, which at first turned black all over as the organic matter contained in the film burnt itself away, should now have become clear again. Hold the crucible tongs just over the plaque, taking care not to touch it or shake any dust over it, and see if a reflection of the former is visible. If so, the enamel has fused, and the fireclay support with the plaque may be removed to the mouth of the furnace till they are no longer red. The plaque may be allowed to cool on dry wood or on powdered plaster of Paris. Copper enamels may be taken red hot from the furnace and left in the open to cool on either of these supports.

FAILURES IN FIRING.

The plaque, tile, medallion, or whatever it is, should have a perfect and brilliant glaze when cool, with a rich, even image. A dull glaze indicates insufficient firing, and may be remedied by firing again. A muddy-looking, sunken image indicates excessive firing, and obviously cannot be repaired. It must not be omitted to turn the work during firing, or the picture and glaze will be uneven and patchy—a defect also beyond remedy. There will probably be many failures at first, until the worker has become thoroughly acquainted with the correct degree of heat and the exact details of firing, for which purpose a number of experiments should be made on cheaper tiles and plaques, of "seconds" quality, obtainable of dealers in photo-ceramic materials. Opal glass will do very well for trial firings, if nothing better is available, but requires a very gradual application of heat, and needs, in other respects, slightly different treatment to plaques, tiles, or enamels. In any case, it is important to maintain the furnace at the correct temperature for fusing the enamel. A few minutes are sufficient to melt this, and if left in after the surface assumes its peculiar lustrous and watery appearance the colours will be lacking in brilliancy. No attention need be paid to the various alterations of

tint through which the colours pass during firing and cooling.

THE ROSE COLOUR TEST.

The correct heat for firing may readily be ascertained by means of a special vitrifiable rose colour made for the purpose. This is mixed with a little lavender oil and applied to a trial piece of china or opal which is placed in the furnace together with the actual work. At the right temperature the rose colour will have assumed its proper tint and become glazed. The heat must not be allowed to exceed this point for ordinary purposes. An excessive temperature is indicated by the colour taking a bluish tinge, and if this occurs the heat should be lowered immediately, or the work will be burnt.

CERAMIC PHOTOGRAPHS ON CHINA.

Ceramic photographs transferred to ordinary china could not be successfully fired without a slight modification of the ordinary procedure. The glaze on china requires a much higher temperature for melting than that necessary to fuse the ceramic colours. In consequence, if sufficient heat is used to fuse the surface of the china, the ceramic image will be damaged in tint or burnt. On the other hand, if only the usual temperature for firing the transferred picture is employed, the latter will not be properly attached to the china, but may be easily abraded or rubbed off. These remarks, however, do not apply to what is known as "soft-glazed" earthenware, which possesses a readily fusible surface. To work satisfactorily upon china, the surface must be treated in a special manner, known as "ground-laying," which consists of the application of a soft flux mixed to the consistency of paint with a little oil of turpentine and a small trace of fat essence. This is applied to the surface of the work, before transferring the picture, in a thin, even coating applied with a brush. A badger-hair softener (Fig. 481, p. 315) is useful for finally smoothing down. If a coloured ground is desired, suitable tints of ceramic powder may be

added to the flux. Sometimes very charming effects may be obtained in this way. In any case, the ground must be fired and allowed to cool before applying the transfer. Ground laying is now undertaken by various firms especially for photo-ceramic purposes.

CONCLUDING HINTS.

Extreme care is required in all the operations connected with this description of work; slipshod or haphazard manipulation will inevitably lead to failure. Dust, it must be again insisted, is especially to be avoided. Before starting, it is advisable to well sprinkle the floor of the room with water, which will

probably suffice to lay the floating dust. On no account should any sweeping or dusting be done immediately preceding any of the manipulations. It is sometimes advised to charge the air with moisture by means of a spray diffuser or vaporiser; but this seems unnecessary, involves waiting, and has the further disadvantage of rendering the room too moist for developing, which accordingly has to be done elsewhere. As complaints are often made of difficulty in procuring materials for this process, it may possibly be useful to state that James Hancock and Son, Diglis Ceramic Art Colour Works, Worcester, are specialists in this direction, and supply all necessary requisites.

ANIMATED PHOTOGRAPHY.

INTRODUCTION.

By the cinematograph of to-day the spectator is shown, thrown upon an ordinary lantern screen, a photographic picture apparently endowed with all the life and movement of the original subject. An express train may, for instance, be seen gradually approaching, tearing past with every similitude of violent energy, and disappearing in the distance; or a state pageant is reproduced, in which every detail of the showy spectacle and the applauding crowds seems to live again. The principle on which this remarkable scientific triumph depends is, briefly, as follows. The image of any object on the retina of the eye does not at once disappear immediately that object is withdrawn, but lingers for a short space before it fades away. The period for which the retinal impression remains is about $\frac{1}{10}$ of a second. If, then, ten or more slightly different pictures of the same object are presented to the eye within the space of a second, the mind is unable to distinguish any interval between them, but appreciates only a single picture, which appears to change during its presentation. This phenomenon is known as the "Persistence of Vision," and appears to have been noticed from time immemorial. It is vaguely alluded to by Lucretius, about 65 B.C., and is definitely treated of by Ptolemy in the second book of "Optics," written about 130 A.D.

EARLY APPLICATIONS.

The first recorded application of this principle to cause the illusion of motion was by Plateau, of Ghent, who, in 1832, designed a device known as the Phenakistoscope. A circular disc, having radial slits round its periphery, was blackened on one side, while on the other were drawn or painted the various phases of

motion to be represented. On holding the disc in front of a mirror, with the blackened side to the eye, and revolving it on its axis, a moving picture was seen by looking through the slits. About 1845 the Zoetrope, or "Wheel of Life," was introduced. This consisted of a cylindrical box, open at the top and revolving on a stand. Round its side were cut vertical slits, and the pictures were arranged on a long strip of paper which was placed round the inside of the cylinder and inspected through the slits as the arrangement was revolved. In 1864 Ducos du Hauron appears to have turned his attention to the subject and to have made several practical suggestions. In 1877 the Praxinoscope, a variation of the Zoetrope, in which the pictures were seen in revolving mirrors, was devised by C. E. Reynaud. These, of course, were all non-photographic applications. In 1877, however, E. Muybridge, with an electrically controlled battery of cameras, succeeded in obtaining a succession of photographs of moving horses, etc., which he copied on glass discs and projected in the lantern. Later, O. Anschütz adapted the Zoetrope for the display of photographs, naming his arrangement the Tachyscope. In 1882 M. Marey published the description of his "Photographic Gun," an instrument founded on the earlier but more cumbersome "Photographic Revolver" of Janssen, which was used for obtaining a sequence of astronomical photographs. By means of this arrangement, Marey was enabled to secure a succession of pictures on a circular plate, showing the flight of birds, etc. These were afterwards combined in the Zoetrope.

THE FIRST CINEMATOGRAPH.

It was not until 1890 that Mr. W. Friese-Greene and Mr. M. Evans introduced what was

practically the predecessor of the modern cinematograph. By a special camera they succeeded in obtaining a large number of negatives in rapid succession on a length of celluloid film: they also designed an arrangement for projection at the same rate of speed. In 1893 T. A. Edison reduced animated photography to a commercial success by producing the Kinetoscope. A series of small photographs were taken on a length of perforated celluloid film, and from the negative so obtained was printed

gave the first demonstration of their now well-known Cinematograph. In 1896 Mr. R. W. Paul patented his Animatograph, at first known as the Theatrograph. These may be called the pioneers of animated photography. Of late years many advances have been made in the construction of apparatus, and numerous taking and projection devices have been placed on the market. A fuller description of the more important of these will be given later.

THE CAMERA.

Perhaps it will be the best plan to explain the action of one or two standard types of apparatus, rather than to give a number of loose directions which, in many cases, would not be applicable. For the purpose of illustration, one can hardly do better than choose the Gaumont "Chrono" camera (Fig. 875) as a splendid example of a high-class arrangement for taking cinematograph films. The camera may also be used for projection, although a separate outfit for the latter purpose is advised. On top of the apparatus will be seen the light-tight box which holds the spool of film; this is capable of taking a length of 330 feet of Edison-gauge film, the size generally adopted as the most convenient. The Edison gauge, it may be mentioned, is $1\frac{1}{2}$ in. wide, the picture occupying a space of about $1\frac{1}{4}$ in. by $\frac{7}{8}$ in. There are four perforations on each margin to every picture. At the side of the camera is attached a large view-finder; while the lens, which is in a line with this, has a shutter with an adjustable opening which serves the purpose of a diaphragm. A special feature is a panoramic base, detachable at will, by which the camera can be rotated to follow any moving object. An indicator is provided to show the length of film used and how much is left.

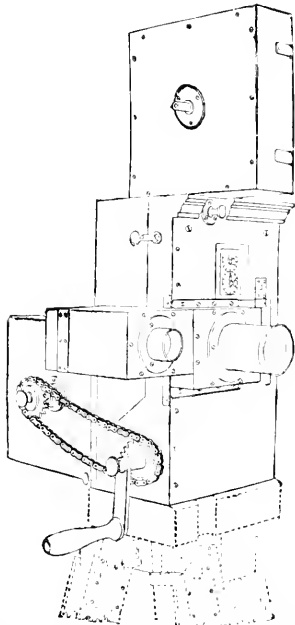

Fig. 875.—THE GAUMONT "CHRONO" CAMERA.

a positive, which was joined at the ends, suitably illuminated by a small electric lamp, and viewed through a magnifying eyepiece. As the film was rapidly passed before the observer in a specially designed cabinet or stand, a slotted disc was revolved in front of it, allowing a fresh picture to be seen at each revolution. In 1893 M. Demeny patented his Chronophotographe, at first called the Biograph, a name afterwards withdrawn. Mr. Birt Acres, in 1895, was the next to introduce an improved form of camera and projection apparatus, with a special arrangement for stopping the film at each revolution of the shutter. Almost simultaneously, Messrs. A. and L. Lumière, of Paris,

PREPARATIONS FOR EXPOSURE.

The shutter is first set to the required aperture. The largest opening possible should always be used, except for scenes with very rapid movement and in bright sunshine. Seeing that the lens is uncovered, focussing is done on a piece of fine ground glass temporarily placed in the film trap, screwing the lens in and out until the focus is considered satisfactory for the particular purpose in hand. Then it will be noticed that the view-finder coincides with the picture on the ground glass. The

ground glass is now removed, and the film, which has previously been wound, gelatine side inwards, on a spool in one of the light-tight boxes, is placed on top of the camera. About $1\frac{1}{2}$ feet of film should be left outside the box to thread through the mechanism of the camera. This is carried over and under various wheels, and past the shutter, in a special manner, which will vary with the apparatus and need not be here described. The loose end is brought out at the back of the camera, which is then closed, the film being finally passed through the slit in the receiving box, pulled tight, and the end fixed in the receiving spool. The chain and cog which drive the winding gear being properly adjusted, the camera is ready for the exposure.

TAKING THE PICTURE.

After seeing that the camera is level, and that all the preliminary arrangements have been satisfactorily carried out as described, the handle is turned from left to right at a regular speed of about two revolutions per second. This should be started just before the commencement of the incident it is desired to record. The picture is watched carefully in the view-finder, and if necessary the camera is turned on the panoramic base to follow the motion, making every endeavour to move the camera at an equal rate. The winding of the film on the receiving spool has to be adjusted to suit the gradually increasing size of the roll of film. This is done by what is known as the take-up gear, a slipping wind governed by a spring, which, on being regulated by the operator, tightens or slackens the winding. This requires attention from time to time, since, if too tight, the film may be broken; while, on the other hand, if too slack, it will not be wound. When the film has all been run through, the slot of the receiving box is closed and the latter removed. It may not, of course, be necessary to use all the film on one occasion, in which case the indicator will show how much is left, and this may be kept for future use. All the working parts should be kept well oiled with vaseline, except those portions which the film touches. Particular care should be taken to avoid dust and grit, and to keep the lens perfectly clean, since carelessness in this respect will result in pin-holes and other defects on the film.

DEVELOPING THE NEGATIVE FILM.

Either a long dish may be used, as illustrated by Fig. 199 (p. 123), or the film may be wound, gelatine side outward, round a wooden frame, as shown on page 121, and immersed in a suitably large tank holding the developer. Each end of the film is fastened by a clip or by drawing pins. Another method is to wind the film spirally round a large drum, similar to that shown by Fig. 443 (p. 314), the developer being contained in a dish or tank underneath. Practically any developer may be used, but one which will give a bright clear image, full of detail and free from stain, is to be preferred. Amidol is very suitable for the purpose. Development is best done by the factorial system, since it will be very awkward to examine progress in the ordinary manner. This difficulty may, however, be overcome by winding the film on a glass drum having a ruby electric lamp inside it. Hardness or chalkiness must be carefully avoided, as this will appear very objectionable in the final result. Special attention should also be given to the prevention of stains, scratches and pin-holes. When developed, empty off the solution and pour in clean water, in which the film may be allowed to remain for about a minute; or a separate tank may be kept for this purpose, if preferred. Then immerse the film in a fixing bath composed of hypo., 2 lbs.; sodium bisulphite (crystallised), $\frac{1}{4}$ lb.; water, 5 quarts. Leave the film in this until perfectly clear, then wash in running water for about an hour, finally treating it in a glycerine bath for five minutes, and hanging up to dry on the frame. The glycerine bath is composed of water, 1 gallon; alcohol, 1 pint; glycerine, 5 ozs. When perfectly dry, the film may be rolled up, carefully wiping off any dirt or water marks on the celluloid side.

MAKING THE POSITIVE FILM.

From the negative film, obtained as previously described, a positive film has now to be made by contact. Great care is required in order to secure perfect registration between the two films, or the pictures will not be properly spaced, and other irregularities, which are enormously magnified when projected on the screen, will be present. In many cases, the camera employed for taking purposes may be

used for making the positive film, by threading the two films in contact with each through the ordinary mechanism of the apparatus, replacing the lens by a narrow slot. A more elaborate contrivance for working on a large scale is that designed by Mr. Jenkins, of New York (see Fig. 876). The two films are kept in absolute registration by means of a toothed sprocket wheel which engages in the marginal perforations, and pass in contact with each other between two plates, above which is a shielded incandescent bulb. The exposure may be varied by the insertion of slotted cardboard diaphragms between the source of light and the film. Separate reels are provided for

fully drying in a place free from dust, some slight retouching may be necessary here and there. Every endeavour must be made to avoid pinholes and scratches, since these will utterly spoil the success of a film by causing an irritating twinkling or flashing effect, as the case may be.

RAPID PRODUCTION.

The feat, now quite a commonplace, of showing on the screen, at night, events which have happened during the same day, obviously requires specially rapid working. Directly the film has been exposed, no time is lost in forwarding it to those charged with

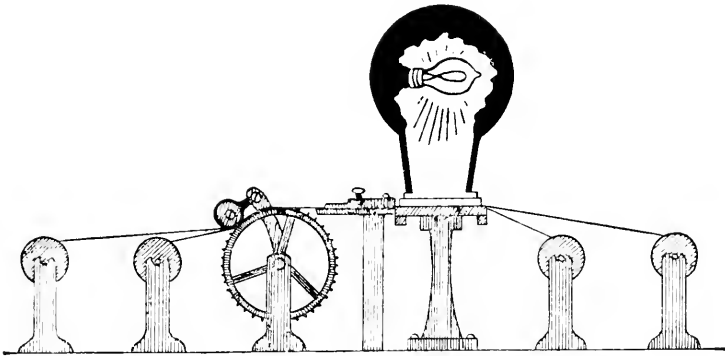

Fig. 876.—JENKINS' PRINTING ARRANGEMENT FOR MAKING POSITIVE FILMS.

the negative film, the unexposed positive film, the exposed positive film, and another for re-winding the negative film as it passes along. Since all the reels are interchangeable, it is only necessary to remove the negative film from one end of the apparatus to the other in order to start operations afresh, after the first length of positive film has been exposed.

DEVELOPING THE POSITIVE FILM.

The positive film is developed in just the same manner as the negative film, but, with a view to stopping as little light as possible during projection, it should, of course, be thinner. All possible detail should be secured, avoiding the rendering of any portions of the picture as clear film, since such white patches or spots have a tendency to show up any little amount of flicker or incorrect registration in the machine, which would otherwise pass unnoticed. After fixing, washing, etc., and care-

the development. Developing and fixing are done as speedily as possible, a minimum but sufficient amount of washing is given, and the film is then dried rapidly by the aid of methylated spirit. Directly it is dry, and this may be hastened by using a warm room and a current of air, the positive film is proceeded with, similar means being also taken to expedite the operations in this case. The film is finally examined for defects and rapidly wound on the projection reel by a simple mechanical device.

MAKING TRICK FILMS.

Many of the humorous or sensational effects now exhibited require elaborate and ingenious preparation. To give a single example, the rather gruesome subject of a criminal being guillotined will be considered. All the accessories are properly staged, and suitably dressed actors are provided for the different

parts. The condemned man is simulated by a living individual up to the moment of being laid on the platform of the guillotine, but is then got out of the way as quickly as possible and replaced by a dummy figure dressed in exactly the same manner, the onlookers meanwhile retaining their previous positions. The "execution" is now proceeded with to its apparently dramatic climax. Before the film is completed for exhibition, the portion showing the change from the living figure to the dummy is cut out, and the severed ends neatly joined, so that no trace remains of any contrivance, but the whole seems realistic from start to finish. Such scenes are generally obtained in an elaborately furnished open-air studio, since, owing to the extremely short exposure necessary, only the brightest light can be used.

VARIOUS TYPES OF PROJECTION APPARATUS.

A remarkably large number of different devices and mechanical movements have been proposed from time to time for projecting the film. In many cases, practically the same mechanism is used for both taking and projection, or the two functions are sometimes served by the one apparatus. The object to be attained, generally speaking, is that the film, travelling at a rapid rate, shall have periodical intervals of rest for the purpose of exhibiting each picture as it comes before the lens; while during the period of motion, as the next picture is brought into position, the light is cut off by means of a shutter. All this has to be done so quickly that no interval is perceived between the pictures, nor any interruption of illumination. This, at least, is the principle employed in the majority of modern cinematograph apparatus, although many attempts have been made to dispense with the shutter, so securing a greater percentage of light, or to avoid the intermittent movement of the film. It will be remembered that in the Praxinoscope (*see* p. 664), by means of mirrors, revolving in unison with the band of pictures, an uninterrupted moving image was viewed without the intervention of any slit or shutter, as in the Zoetrope. The same idea has been adapted in several ways for projection purposes, although, at present, such devices are unnecessarily complex and involve the use of too many mirrors, with consequent loss of light.

A battery of projection lenses revolving in unison with the film has also been employed, but is evidently too expensive an expedient for general use. In some patterns of apparatus, however, the shutter is dispensed with by giving a comparatively long interval of rest to the film, coupled with an extremely rapid changing movement. This is satisfactory with the average film, but if the latter happens to be specially light or transparent, sufficient illumination is passed during the period of change from one picture to another to cause a "rainy" appearance, or flickering.

THE INTERMITTENT MECHANISM.

Seeing that the intermittent principle is now adopted by the majority of makers, a few words on the various methods by which it is secured may be useful. The film may be pulled down, picture by picture, by the intermittent grip of two rollers, or by a claw mechanically inserted in the perforations and then withdrawn; a wheel having a single tooth or peg may be caused to move a regularly toothed wheel at definite intervals; what is known as a Maltese cross movement may be employed; the sprocket rollers on which the film runs may be raised and lowered intermittently; a worm or cam actuated by wheel teeth may be used; a revolving eccentric may strike the film between the exhibition of each picture; or the necessary motion may be given by a ratchet gear. These are but a few of the methods suggested or actually employed, a detailed examination of which, with their respective advantages and disadvantages, would, even if space were available, simply tend to perplex the non-mechanical reader. It is therefore merely proposed to describe the main features of one or two of the best known patterns of projection apparatus.

PAUL'S "RELIANCE" ANIMATOGRAPH.

This machine, illustrated by Fig. 877, is of extremely practical construction and has many advantages. The working parts are built on a single casting, each portion of the action is readily accessible and open to inspection, while those components liable to wear are made of tempered steel. The intermittent mechanism shown, with the "film-gate" removed, by Fig. 878, possesses the valuable feature of gradually bringing the film to rest, locking it in position for projection, and then

gradually starting it again, so that sudden jerks or strains are avoided. The expression "gradually" is, of course, only relative, since the whole takes place with great rapidity. The film is passed through a special pattern of "gate" (Fig. 879), and is held in place by stout

fire. Even if the film were to become ignited, the gate would act as an effectual bar to the spreading of the flame. As a further safeguard a drop-shutter is provided, worked by a handle seen to the left of the condenser (Fig. 877). This can be used to instantaneously cut off the

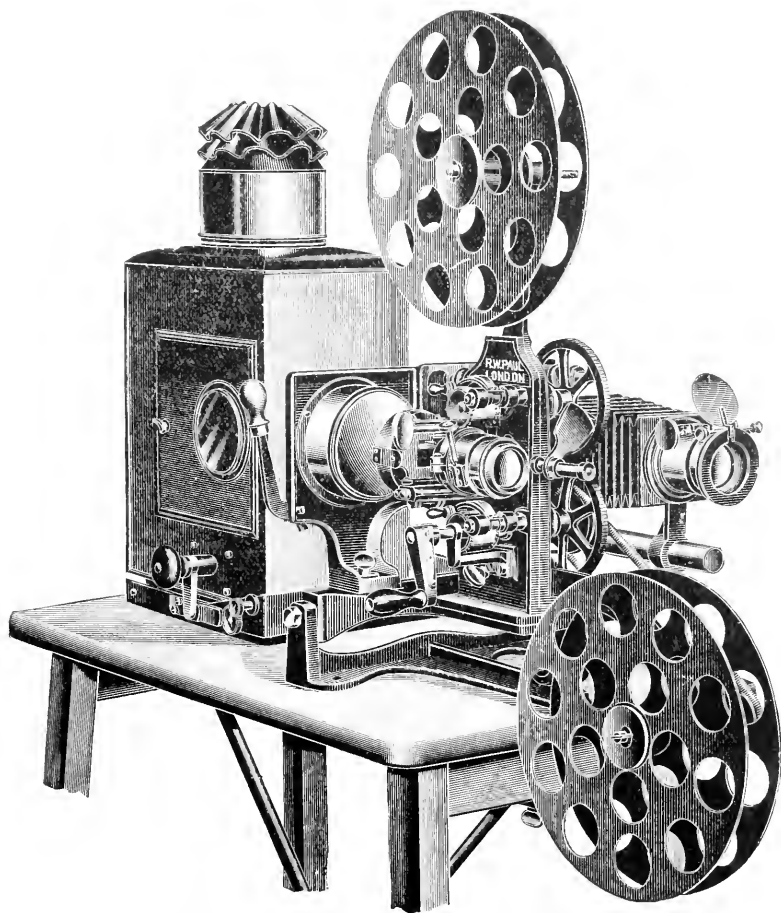

Fig. 877.—PAUL'S "RELIANCE" ANIMATOGRAPH.

polished steel pads which press on the edges of the film only, so that the latter cannot be scratched or otherwise injured. This film-gate consists of a massive casting, deeply ribbed, and is made to hinge behind, but not touching, the film. An upward draught is consequently created in the space between, serving to keep the film cool and acting as a preventive against

light rays if the film stops or anything goes wrong. In the centre of the drop-shutter is a small opening covered with a mica disc which enables the film to be satisfactorily arranged on the screen at starting, while cutting off the heat. A separate condenser is fitted for projecting ordinary lantern slides, together with an optical front for the latter purpose, it being

only necessary to push the lantern body from one side to the other to obtain either cinematograph pictures or stationary slides at will. A useful adjustment is available for tilting the whole apparatus at any desired angle and clamping it firmly in any position without the necessity of altering the stand. Finally, it may be mentioned that the shutter employed is the smallest made, cutting off only one sixteenth of the available light.

by a resistance box. The film is kept alternately moving and stopping by the intermittent grip of two rollers.

THE DEMENEY CHRONOPHOTOGRAPHE.

This apparatus makes use of the movement introduced by M. Demeney, consisting of a cam or "dog" which, actuated by an eccentric motion, regularly pulls down and leaves at rest the film. Messrs. L. Gaumont et Cie., of

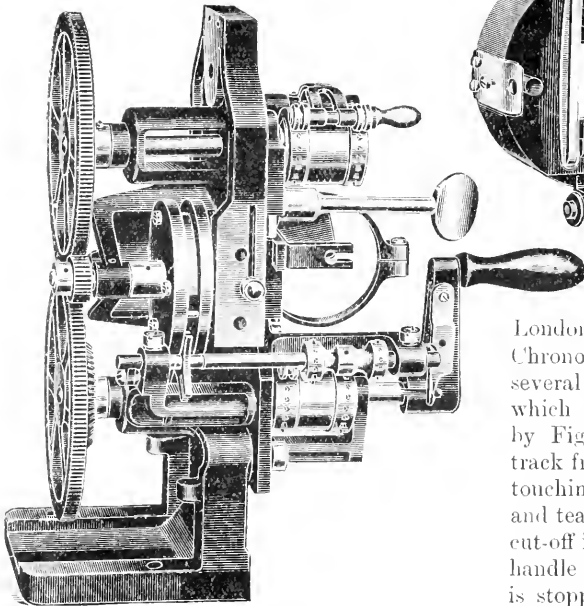

Fig. 878.—ANIMATOGRAPH MECHANISM WITH FILM-GATE REMOVED.

THE BIOGRAPH.

This apparatus, designed by H. Casler, is of specially large and solid construction, and is intended for a larger size of film than that commonly employed, the pictures themselves measuring about $2\frac{1}{2}$ in. by 2 in. The taking apparatus is known as the Mutograph, and the views shown by the familiar Mutoscope, seen on every seaside pier, and at public exhibitions, etc., are small bromide enlargements obtained from a Mutograph film. Both the Mutograph and the Biograph are electrically driven by a motor, the speed being regulated

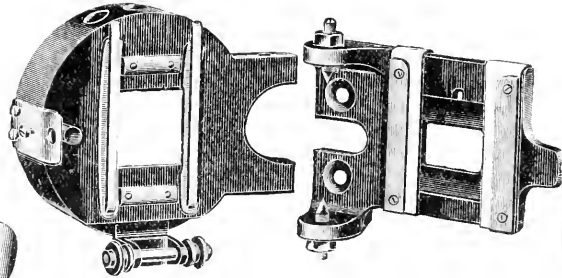

Fig. 879.—DETAILS OF FILM-GATE.

London and Paris, are the manufacturers. The Chrono camera has already been described; several patterns of projectors are made, of which one—the "Professional"—is illustrated by Fig. 880. The film travels in a hollow track from start to finish, no part but the edges touching the machinery; this saves all wear and tear on the pictures. An automatic light cut-off is provided, which is raised directly the handle is turned and falls instantly the turning is stopped; an asbestos shield is also fitted over the film-trap to prevent heating. A lantern lens is attached to the same plate as the projection lens, and the apparatus slides backwards and forwards to allow the exhibition of either still or animated pictures. The whole arrangement is extremely steady and flickerless.

THE LUMIÈRE CINEMATOGRAPH.

The Lumière film, although the same gauge as the Edison standard, has only two perforations per picture, one at each side. The movement is obtained by means of a claw, set in action by a cam-disc, and engaging in the perforations. The film is held in position by steel springs pressing on the edges only. It will be remembered that the Lumière apparatus

was one of the first to be publicly exhibited. Its mechanism, characterised from the beginning by simplicity and sureness of operation, has of late years been still further improved.

THE KAMMATOGRAPH.

In all the apparatus previously considered, both the negative and positive pictures are

an ordinary optical lantern. Obviously the operations of development, etc., are wonderfully simplified, since the circular record may be treated in just the same way as an ordinary plate; while the positive presents no more difficulty to obtain than would be met with in making a lantern slide by contact. A further advantage secured is absolute immunity from fire dangers.

OTHER APPARATUS.

There are many other excellent makes of apparatus for the taking or projection of animated photographs, which can only be briefly mentioned. Hughes' Bio-Pictoscope, Roto-Bioscope, and Moto-Bijou Camera; Watson's Motograph, which is no larger than an ordinary hand camera, and may be used either for taking or for projection with an ordinary optical lantern; the Prestwich instruments, made in various forms, from those intended to take a larger film than usual down to the ingenious "Junior," which employs a daylight spool only $\frac{1}{2}$ in. wide; the Warwick "Bioscope"; Anthony's "Biopticon"; the "Birtac," designed by Mr. Birt Acres; the "Cymnagraph" and "Rollograph," made by Messrs. J. Levi & Co.; the Clement and Gilmer "Vitagraph," of several patterns, are all built on scientific principles and capable of doing excellent work. This by no means exhausts the list of available apparatus, which might easily be extended to fill a separate volume.

HINTS ON EXHIBITING.

Absolute rigidity of the stand and apparatus must be secured. A hollow body should not be used for this purpose, since it will not only tend to cause vibration but will distressingly increase the noise. The machine should be well oiled before use with good clock or cycle oil, and a small quantity of vaseline should be placed on the spool spindles. The light must be well centred on the screen before the film is inserted. While inserting the film, and whenever the latter is not in motion, the drop-shutter or other device must be used to cut off the light, or the heat from the condenser may cause the stationary film to catch fire. The amount of picture shown is adjusted by a masking device, which will vary with the construction of the apparatus. During the

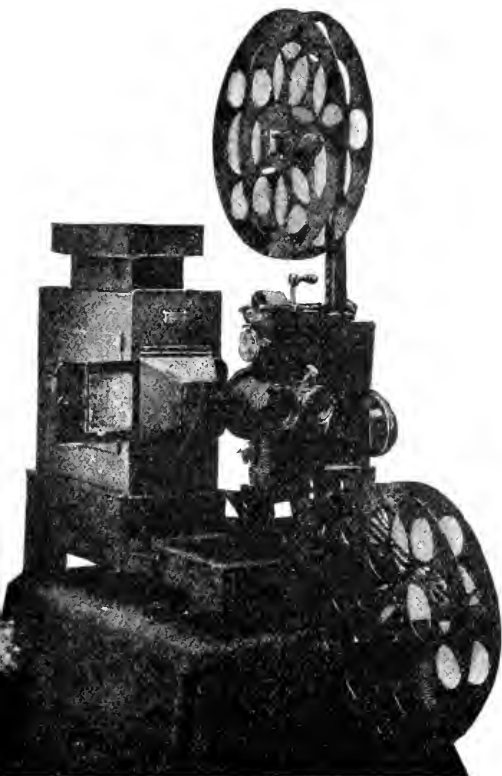

Fig. 880.—THE "PROFESSIONAL CHRONO" PROJECTOR.

taken on lengths of celluloid film. The Kammatograph, an interior view of which is shown by Fig. 881, takes a circular glass plate, 12 in. in diameter, on which the photographs are obtained in a spiral series. Two patterns are made, both of the same size, but taking 350 and 550 pictures respectively, the former, of course, being larger. The resulting animated photograph lasts from half to three-quarters of a minute. The apparatus is available for either recording or for projecting in connection with

intervals of inserting fresh films, etc., the audience should be kept interested by the display of ordinary lantern slides. "Reversing"—*i.e.* passing a film through the machine end first—is sometimes employed to produce unusual and humorous effects; as the pictures will, of course, be upside-down, a reversing prism or mirror is required on the

Glycerine has also been used for the same purpose. Messrs. Lumière are responsible for the introduction of a spherical glass flask filled with water, which serves both as a condenser and a heat-absorber. At the upper portion of the flask a small piece of carbon is suspended to withdraw the gases liberated by the gradual heating of the water.

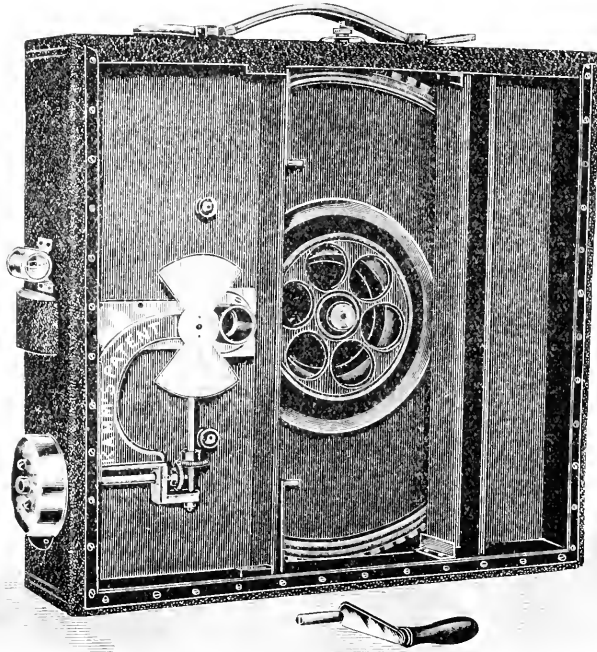

Fig. 881.—INTERIOR VIEW OF "KAMMATOGRAPH."

projecting lens to erect them. Comic films of this description are now, however, more usually reversed when made, so that reversal in the lantern is unnecessary. After a film has been shown it requires re-winding; for this purpose several convenient forms of winder are made; while, in some projectors, the top spool is supplied with a re-winding gear, which can be brought into action when required.

THE ALUM TROUGH.

In order to absorb as many of the heat rays as possible before they reach the film, a glass-sided trough containing a solution of alum is interposed between the light and the condenser.

THE ILLUMINANT.

The electric arc is the most suitable illuminant for cinematograph projection. A resistance, or a choking coil, properly adjusted to the current, will be required. Where electric light is unobtainable, the oxy-hydrogen light may be employed. It should be mentioned that the leading British insurance companies absolutely refuse to entertain the use of an ether saturator; if this is used it must be at the operator's own risk. The Nernst-Paul High-power Electric Projection Lamp has several advantages; it may be connected to any ordinary incandescent fitting, or other source of supply, carries its own resistance, and will give



NEGATIVE PRODUCED BY X-RAY'S.

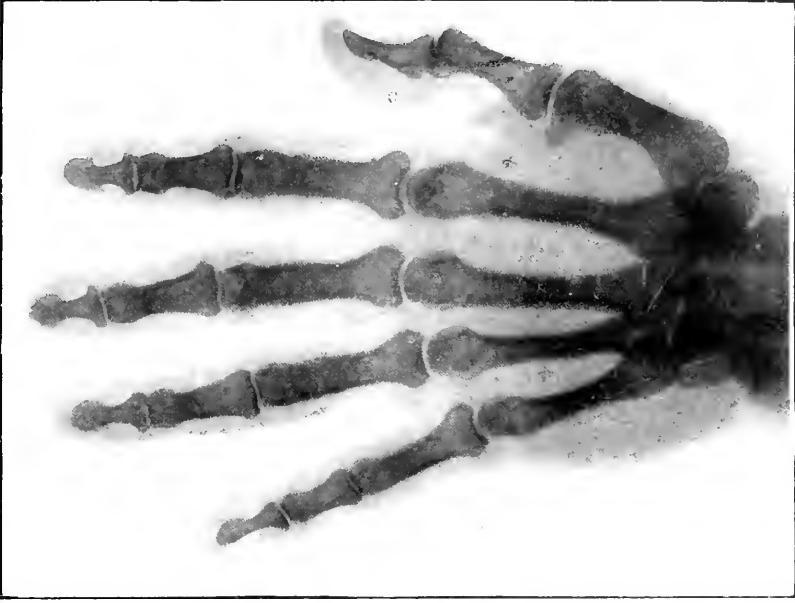

POSITIVE PICTURE FROM X-RAY NEGATIVE

a light sufficient for a ten-foot disc in a hall of moderate size.

COLOURING FILMS.

Cinematograph films are sometimes, though not very frequently, tinted or coloured. This is a work requiring much patience and the greatest care, since the outlines of objects have to be very strictly kept to. The necessity for this will be readily understood when it is considered that any slight overlapping of colour, or lack of identity in this respect between succeeding pictures, will cause the object to apparently bulge out or contract; or, in other words, will give rise to an objectionable movement in what should, perhaps, be stationary. The number of pictures to be dealt with also renders the operation very tedious. Obviously, only the most transparent colours should be used, applied as lightly as possible. Aniline dyes are very suitable for the purpose. Films of special subjects are often improved by toning to a warm, or any other desired colour. Fire scenes, for instance, may be effectively toned to a red, or seascapes to a green tint. Attempts have been made to use triple projection for the production of animated photographs in natural colours, but the inevitable loss of light is, as yet, a difficulty to overcome.

ANIMATED PHOTOGRAPHS IN BOOK FORM.

A series of pictures representing consecutive phases of motion may be printed on paper and made to form the leaves of a book. When these leaves are bent back, and allowed to escape in rapid succession by slowly withdrawing the thumb, an animated picture is seen.

Several simple arrangements of this kind have been designed for use in the hand, while the principle has been further elaborated in various coin-freeed machines, such as Casler's Mutoscope and Lumière's Kinora, in which leaves or cards containing the pictures are mounted radially round a cylinder, and caused to slip quickly past by turning an outside handle.

CONCLUDING HINTS.

The film should be treated with great care, since it is very susceptible to damage. If it should happen to get torn across, a picture must be sacrificed, the ends carefully trimmed and scraped so that they join without a projection, and a cement composed of celluloid dissolved in amyl acetate, or in acetone, used for joining. The two ends should be pressed firmly together, after touching with cement, between a pair of glass plates greased to prevent sticking. A broken perforation may be replaced with a new piece of perforated celluloid in a similar manner. It is worth knowing that the vibration and flickering which are still the chief defects of animated photographs (although lately a great improvement has been made in this respect) may be rendered almost unnoticeable by an ingenious device introduced by M. Gaumont, under the name of "La Grille." This consists of a black fan pierced with a number of small holes. When it is quickly moved in front of the observer and the picture viewed through the holes, the flicker almost entirely disappears. Stereo-animaphotography is fully treated in the section dealing with Stereoscopy.

TREATMENT OF RESIDUES.

ADVISABILITY OF COLLECTING RESIDUES.

In the ordinary work of an amateur, waste cuttings from prints, spoilt negatives, and all used solutions are commonly thrown away because the amount of silver and gold which they contain is so small that their recovery would not repay the time and trouble required. When, however, photographic operations are carried out on a larger scale, the losses become considerable unless steps are taken to save the residues and extract the precious metals which they contain. Spoilt prints and cuttings, old fixing and toning baths, waste negatives and washings from prints all contain silver; the toning baths contain, in addition, some gold which has not been reduced, while old platinum and uranium toning baths will retain more or less of these metals. Cuttings from platinotype papers and the developing baths used for these prints may also contain platinum.

SILVER WASHINGS AND CUTTINGS.

The washings from silver prints hold the unaltered silver haloid in suspension. They should be run into a large tub, and, after standing for a few hours, the silver chloride will settle out, leaving the liquid clear; the latter may then be decanted off. This process should be repeated many times until a considerable quantity of the material has been obtained, when it may be collected upon a filter paper and dried. It is convenient to refer to this as Precipitate A. Cuttings and spoilt prints should first be converted to an ash; this can be done by setting fire to them in a clean fire-grate or in an old galvanised bucket in the open air. The ash should

be kept in a box until a considerable quantity of it has accumulated; it will contain the silver principally in a finely divided metallic state, but there may also be present some unaltered chloride or bromide. When sufficient is collected, it should be placed in a large earthenware bowl and treated with nitric acid, which will dissolve out the silver as nitrate. Red fumes of nitrogen peroxide are evolved during the reaction, and as



Fig. 882.—ARRANGEMENT FOR FILTRATION.

they are exceedingly irritating it is best to place the bowl in a fume chamber. When the reaction is over, the liquid should be diluted with water and filtered through a fine linen cloth supported upon a wooden stand, as shown by Fig. 882.

RECOVERY OF SILVER CHLORIDE.

The solution, containing the silver as nitrate, will also include impurities derived from the ash of the prints, hence it will be found best to separate the metal as chloride, and for this purpose sodium chloride (common salt) should be added in

slight excess. If too much is used some of the silver chloride will be re-dissolved. On standing for a short time, the silver chloride will settle to the bottom of the liquid and thus allow the latter to be poured off quite clear. The precipitate may, in a similar way, be washed with water two or three times, on each occasion allowing the precipitate to subside, and then decanting the clear liquid. Finally the precipitate should be collected upon a filter paper, and dried. It may be added to Precipitate A for further conversion into silver. The residual ash, after treating with nitric acid, may still contain some silver as unaltered chloride or bromide. This may be removed by neutralising with washing soda and then adding a solution of sodium thiosulphate (hypo.). After standing for about an hour, the liquid should be filtered off through the cloth and then added to the old fixing solutions.

TREATMENT OF OLD FIXING BATHS.

Old hypo. fixing baths may be placed in a tub by themselves. When this is full, a small quantity of potassium sulphide should be added and the liquid well stirred. The sulphide should be in slight excess. The precipitate formed is silver sulphide; when this has subsided, the clear liquid should be decanted and the process repeated until a sufficient quantity of the sulphide is secured. The precipitate should then be collected upon a filter paper, dried, and heated in a crucible at a white heat, pure metallic silver being obtained. If, however, a furnace is not at hand, the precipitate should be placed in a dish and treated with *aqua regia* in the fume chamber. This will convert it into chloride of silver, and, water being added, it may be filtered off and placed with Precipitate A.

WASTE PLATES, NEGATIVES, AND SPOILT EMULSION.

Waste plates may be stripped of emulsion by boiling with a little water, and any spoilt emulsion should be added to this. The mixture is boiled for several hours

with dilute sulphuric or hydrochloric acid, which will destroy the gelatine and liberate the silver salt. The latter is then filtered off and added to Precipitate A. There are two ways of dealing with Precipitate A. It may be mixed with twice its weight of dry carbonate of soda and a little powdered fused borax and heated in a crucible in a furnace; for this purpose a Fletcher's "Injector" furnace will be found very suitable. When the whole of the contents of the crucible are in the fused state, they may be poured into a conical iron mould. On cooling a little, the mould is inverted and a button of pure silver will then be found below the slag; this may be easily separated by dropping the mass into cold water. Another method is to suspend Precipitate A in water, adding caustic potash and milk sugar, and boiling the whole for several hours. The chloride of silver will then be decomposed and pure, finely-divided metallic silver deposited as a grey powder. This should be filtered off, dried, and heated strongly to destroy any organic matter which it may contain.

MAKING SILVER NITRATE.

The silver obtained by these processes of recovery will always sell at market value, but, if desired, it may be converted into silver nitrate for the preparation of emulsion, etc. For this purpose the metal should be placed in a porcelain evaporating dish and treated with nitric acid. When the silver is all dissolved, the solution should be evaporated to dryness on a water bath. Fresh water is added and again evaporated off to ensure the expulsion of the excess of nitric acid; the salt should then be dissolved in water and the solution allowed to evaporate spontaneously for the formation of crystals. The dish should be covered with a clean sheet of paper to prevent dust gaining access, otherwise the nitrate will be slightly reduced.

THE ZINC METHOD OF RECOVERING SILVER.

The silver may be recovered in another way. All the hypo. fixing baths should

be kept in a tub and, when this is full, the Precipitate A produced from the other residues may be stirred with it until no more will dissolve. The clear liquid is then decanted into a large bowl, in which a quantity of granulated zinc has been placed. After acting for a few hours the liquid may be emptied off and a fresh quantity poured on, until the whole has been treated. The zinc, now covered with a deposit of silver, should then be washed and treated with dilute sulphuric acid until the whole of the zinc is dissolved out, leaving behind finely divided metallic silver. Unless the zinc is chemically pure, some carbon and lead sulphate will remain with the silver, so that it will be best to convert it into nitrate as already described, and to filter the solution through a plug of glass wool placed in the stem of a glass funnel.

OLD TONING BATHS.

These will contain both gold and silver. They should be kept in a jar or tub until a sufficient quantity for treatment has been obtained, the collected solution being then concentrated by evaporation in a dish. After concentration, granulated zinc should be added, and the whole allowed to stand overnight. In the case of the acetate bath, both the gold and silver are deposited in the metallic state, but with the sulphocyanide the gold alone appears to be deposited in the metallic state, and the silver as a double sulphocyanide of silver and zinc. The zinc should be treated with nitric acid and heated; the residual zinc is then dissolved out, the silver is converted into the insoluble cyanide, and the gold is unaffected. After

decanting, the precipitate should be treated with ammonia, which dissolves the cyanide of silver, leaving behind the gold. The latter should be washed several times with water and then boiled with *aqua regia*; on evaporating to dryness the gold is obtained as chloride ready for use. The ammoniacal solution of silver cyanide should be treated with nitric acid in slight excess, whereby the cyanide is precipitated. This is then collected on a filter paper and added to Precipitate A.

RECOVERY OF PLATINUM, URANIUM, ETC.

Platinotype clippings should be burnt to an ash and treated with *aqua regia*; the solution is diluted, filtered off, and added to any old platinum toning or developing baths. The baths may be concentrated and treated with zinc, as in the recovery of gold from ordinary toning baths, the platinum being converted into platinum chloride in an exactly similar manner. Old uranium toning baths should be heated with *aqua regia* to destroy the ferricyanide, and ammonia then added in excess. The precipitate should be collected on a filter paper, washed several times with hot water, and finally boiled with the least excess of acetic acid. The solution is evaporated to dryness to expel excess of acid; the resulting acetate may then be used for the preparation of a new bath. In preparing pure solutions and in washing precipitates distilled water should always be used. Tap water contains chlorides, which give a precipitate with silver nitrate, or sometimes there is even sufficient organic matter to cause a reduction with salts of gold and silver.

PHOTO-MECHANICAL PROCESSES.

INTRODUCTION.

UNDER this heading are included a number of different processes in which an image or picture obtained by photographic means is treated in such a manner that it can be inked and printed from in a press. There are various ways in which this end is attained. In the collotype process a picture secured on a glass plate, or other suitable material, sensitised with bichromated gelatine or albumen, is moistened and inked. The image, being of different degrees of solubility according to the extent of the light's action on its various portions, may then be developed in water, leaving the ink only where it is required. In some cases the gelatine image is developed before inking, the procedure in other respects being the same. In photo-lithography a print is secured as before mentioned, but on a suitable transfer paper, and transferred to stone for printing from. In photo-zincography the image is obtained on a zinc plate, either direct or by transfer, and then etched with acid. In the half-tone process the image is broken up into minute dots by the interposition of a finely-ruled screen between the lens and the plate, the resulting negative being used to obtain a print on bichromated zinc or copper blocks, which are then etched with acid. There are many other photo-mechanical processes, the most important of which will be explained in due course.

BASIS OF ALL PROCESSES.

It will be noticed that, in all the processes mentioned, the essential feature is the adoption or turning to account of the

property possessed by a bichromated colloid body, such as gelatine or albumen, of becoming more or less insoluble under the action of light. Other bodies, bitumen for example, having similar properties, are also made use of. A full explanation of the exact chemical reactions taking place will be found in the preliminary remarks on the carbon process (pp. 156 and 157), and in the section dealing with the Chemical Action of Light. Photo-mechanical operations differ in this respect from ordinary photography—that, whereas in the latter everything is sacrificed to obtaining a satisfactory printed-out or developed image, in the former the essential requirement is that the image shall be readily capable of inking or etching, as the case may be.

SIMPLE FORM OF COLLOTYPE.

In the well-known Photo-Autocopyist is seen a simplified application of collotype. A prepared parchmentised sheet, coated on one side with gelatine, is sensitised by a few minutes' immersion in a 2 to 3 per cent. solution of potassium bichromate, with the addition of a small quantity of ammonia. It is then squeezed to a polished glass plate and dried. When dry, the sheet is stripped off and printed under a negative in the ordinary manner, the progress of printing being visible by the formation of a brown image. After printing, it is developed in cold water, which apparently washes away the image, but in reality leaves it in slight relief. The sheet is now surface-dried and stretched on a special frame supplied with the outfit, the gelatine image being then covered with a solution of glycerine,

water, and ammonia, which is left on for about half an hour. The solution is next poured back, and the surplus mopped up with a soft rag. The image may then be rolled with suitable ink and printed from in a letter-copying press.

THE COLLOTYPE PROCESS PROPER.

Paul Pretsch and A. L. Poitevin appear to have been the first to discover that

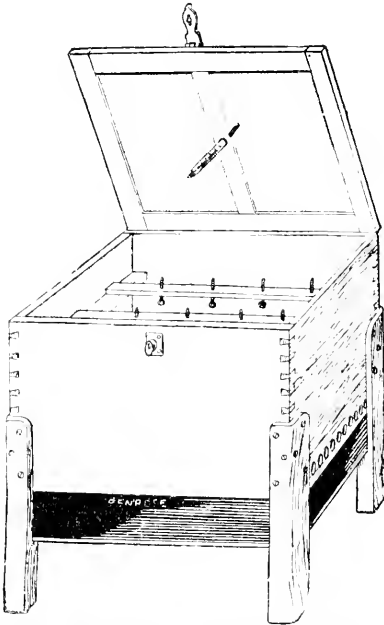

Fig. 883.—DRYING OVEN FOR COLLOTYPE.

chromated gelatine, after exposure to light, will take greasy ink while repelling water. In 1865, MM. Tessié du Motay and C. R. Maréchal introduced certain methods of hardening the gelatine film so that a larger number of impressions might be obtained. In 1867, Ohm and Grossman, of Berlin, and in 1868, Albert, of Munich, adopted the plan of coating the glass with a preliminary substratum of bichromated albumen and gelatine, and hardening this by exposure to light before applying the essential sensitised film, thus securing a better adhesion of the latter. The process now in general use is commonly credited to Husnik. A thick plate of

glass, ground on one side, is employed as a support, and a mixture of albumen and potassium silicate is used as a substratum. Copper, zinc, type-metal, lead, and aluminium have been successfully used instead of glass, and where metal is adopted no substratum is necessary.

PREPARING THE PLATE.

Sheets of plate-glass, from $\frac{3}{8}$ in. to $\frac{1}{2}$ in. thick, and several inches larger each way than the required picture, are necessary. These must be ground with fine emery on one side. A simple way of doing this is to place two plates together, with moistened emery powder between, and work them over each other, renewing the emery from time to time, until the glass is sufficiently ground. If the grinding is excessively fine, the film will not adhere well, but the grinding must on no account be coarse. The plates are next scrubbed with a brush and clean water to remove the emery, and stood up to dry. If metal plates are to be used, zinc is perhaps to be preferred. Level sheets about $\frac{1}{4}$ in. thick may be obtained from any photo-mechanical dealer. They should be thoroughly cleaned from every trace of grease by means of pumice powder and water, and then roughened or grained in a nitric acid bath as follows:—

Nitric acid	$\frac{1}{2}$ oz.
Alum (sat. sol.)	7 $\frac{1}{2}$ ozs.
Water	40 ozs.

The dish should be rocked till the entire surface of the metal is of an even grey tint. The plate is then washed under the tap, and any sediment or scum removed with a tuft of cotton-wool. Boiling water is next poured over the plate, which, when the surplus moisture has been removed with a thoroughly clean wash-leather, is stood up to dry. Copper plates are ground with emery powder similarly to glass: for aluminium, a weak solution of sulphuric acid or a strong alkali is used. Although, as already mentioned, metal plates require no substratum, and are not easily broken, it is a disadvantage that the printing cannot be examined through the back, as with glass.

COATING WITH SUBSTRATUM.

If glass plates are used, the next proceeding is to apply the substratum. There are various formulæ for this, but only Husnik's need be given:—

Albumen	4	ozs.
Potassium silicate	1 $\frac{3}{4}$	ozs.
Water	5	ozs.

These ingredients are thoroughly incorporated and carefully filtered. The mixture is then applied to the plate in much the same manner as a varnish. The plates are now placed in a rack to dry. When dry, they are rinsed under the tap to get rid of any soluble silicate, and again dried. Great care should be taken throughout to avoid dust and grease, and the surface of the film should not be touched with the fingers. The plates coated with substratum will keep very well, and may be sensitised as required.

THE DRYING OVEN.

The plates require to be warmed before sensitising, and have to be dried with a steady heat, away from draught, vibration, or dust, so that a drying oven becomes necessary. This should be provided with shelves having levelling screws, to ensure that the plates shall be kept perfectly level while drying. A suitable pattern is shown by Fig. 883. While the sensitive solution is being compounded, the oven may be heated to the required temperature, 120° F., at which it should be maintained with the aid of a thermometer. The plates are next placed in position and carefully levelled; they can then be left to get warm, with the oven lid open.

SENSITISING THE PLATES.

A good formula for sensitising is as follows:—

Creutz middle hard gelatine ...	1	oz.
Potassium bichromate	50	grs.
Ammonium bichromate	30	grs.
Chrome alum	1	gr.
Water	10	ozs.

The water is divided into two portions,

the gelatine being in one and the rest of the ingredients in the other. When the gelatine has absorbed the water in which it is placed, it is melted at a gentle heat, and the second solution added gradually, stirring well all the time. The mixture must now be filtered (before it has time to cool) through swansdown calico or wash-leather, preferably by means of a filter pump (see Fig. 138, p. 67), although an arrangement of the kind shown by

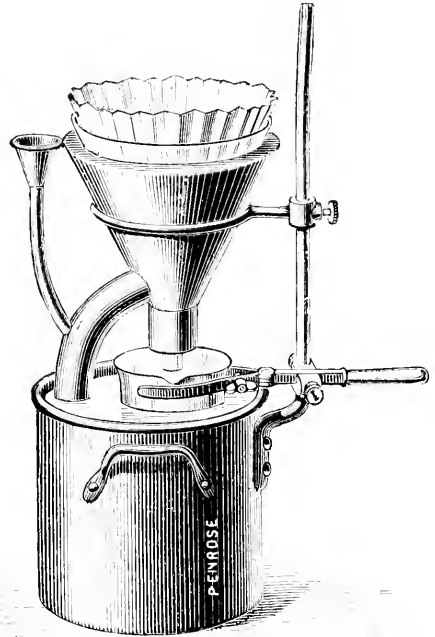

Fig. 884.—WATER-BATH FILTRATION APPARATUS.

Fig. 884 is also very suitable. The warm plates are then taken out of the oven and levelled on a tripod (Fig. 885) or on levelling screws (Fig. 886). About five minims of solution per square inch will be required, a sufficient quantity being placed in a warm measure and poured in a pool on the plate, tipping the latter to cause the solution to flow all over, and helping it, if necessary, with a clean glass rod. When evenly coated, the plate is replaced in the oven and allowed to remain with the lid closed for about two hours, the temperature being kept

constant throughout. When dry, the film should be of uniform colour, free from specks or streaks of any kind, and of matt surface. If it is shiny the oven was too cold, and the results will be unsatisfactory. Wavy marks or shiny streaks are caused by a draught or by vibration. On no account should the oven door be opened while the plates are drying. They will keep for some little time if well protected from light.

EXPOSING THE PLATES.

The plates are ready for printing as soon as cool. The most suitable nega-

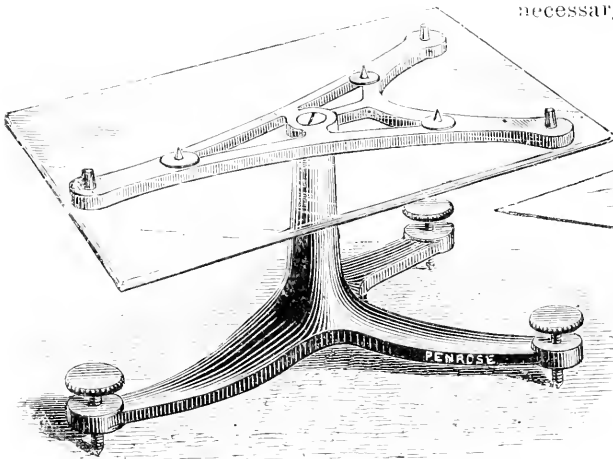

Fig. 885.—LEVELLING TRIPOD.

tives are those which are rather thin, but possessing a full range of gradation and detail: a hard black and white negative is perfectly useless if good results are desired. A printing frame with wedges or screws is to be preferred, so that close contact may be ensured. The progress of printing is judged by looking at the back of the plate, a faint brown image being visible, with full detail in the high lights, when the exposure has been sufficient. The majority of workers, however, prefer the guidance of an actinometer as in carbon printing, and with metal plates this is, of course, imperative. The length of exposure varies according to the negative, the light, and other factors, and can

only be ascertained by a few experiments. The edges of the negative should be masked with black paper or tinfoil, so that the plate may have a clean margin. Some authorities recommend exposing the back of the plate to the light for a short time after printing, to secure better adhesion of the film and less relief in the developed image.

DEVELOPMENT OF THE COLLOTYPE PLATE.

This simply consists of washing out the soluble or unexposed portions in cold water. The plate should be kept in gently running water, or given occasional changes, for about two hours, it being necessary to remove all the bichromate.

By this time the image will be invisible, but will probably possess a slight amount of

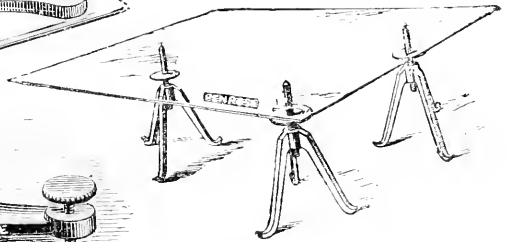

Fig. 886.—LEVELLING SCREWS.

relief. If all has been correctly done, the plate should have a scarcely perceptible brown colour when looked through, and should show a ground glass or matt surface by reflected light. It may now be stood up in a rack to dry, and is better if left a day or so before printing from.

THE "ETCH."

The next proceeding is to treat the plate with a deliquescent or moisture-retaining mixture known as the "etch," with the object of keeping it in a damp condition. The term is altogether a misnomer, since no etching takes place, the plate being simply rendered moist in varying degrees, according to the different action of the light on each part, which

has rendered some portions comparatively non-absorbent, while others are scarcely affected. It is, of course, this greater or lesser moisture of various portions of the plates which causes the greasy ink to be attracted or repelled. A suitable formula for this purpose is:—

Glycerine	24 ozs.
Water	16 ozs.
Sodium chloride (common salt)...	40 grs

The plate is placed on a level table and the solution poured on, care being taken that it is equally distributed. It is left on for a time varying with the correctness of the exposure. An over-exposed plate,

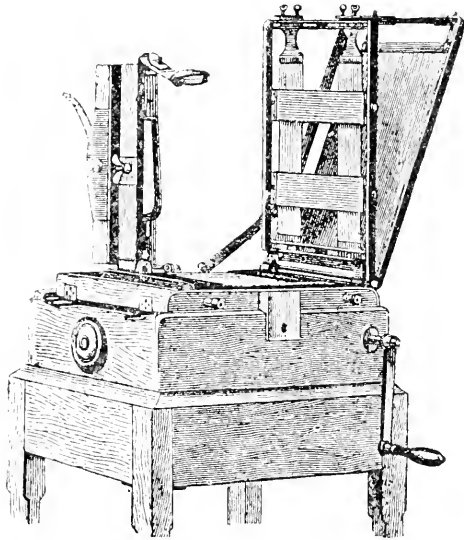

Fig. 887.—WOODEN COLLOTYPE PRESS.

being more insoluble, will require much longer treatment. If left long, however, the plate will absorb too much moisture, yielding a grey, flat print. It is best, therefore, to allow the solution to remain for, say, half an hour, and then to mop it off with a sponge. The plate is now gently dabbed with a soft, dry rag until it is perfectly clean, and it is then inked up. If the etching is seen to be insufficient, the ink can be washed off with turpentine, and another etch given. The etching solution may be used repeatedly.

MACHINES AND PRESSES.

Before treating of the inking process it will be advisable to devote some attention to the different patterns of printing presses and machines specially made for this class of work. For experimental attempts a letter-copying press will give good results; but for any quantity of work a proper colotype printing machine is indispensable. Of these presses or machines there are many patterns, from the simple wooden press shown by Fig.

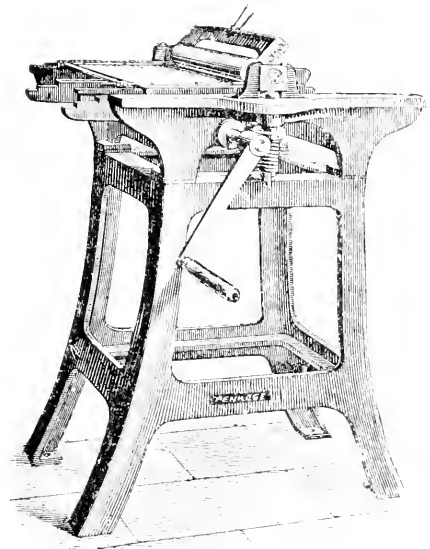

Fig. 888.—COLLOTYPE PRESS, WORKING WITH ROLLER AND ECCENTRIC.

887, which, however, is thoroughly satisfactory in operation, to the most elaborate power-driven cylinder machines. Fig. 888 illustrates a useful type of press working with a steel roller and eccentric. The selection of machinery of this description is so largely a matter of taste and of individual requirements, that it may safely be left to the worker himself, who is hardly likely to purchase expensive plant, adapted only for large quantities of work, until he has gained some little experience of colotype printing in its simpler aspects. When that has been acquired, the advice of a firm of

repute may be safely considered, after a personal examination of the relative merits of various machines.

INKING-UP.

Before placing the plate in the press it should be carefully ascertained that the back is perfectly clean and free from grit, or there will be great risk of the plates cracking under pressure. A sheet or two of blotting paper should be placed between the plate and the bed of the press. Two rollers are required—a fine leather or “nap” roller, and a gelatine or glue roller, also a couple of ink knives and an inking board or slab. The ink should be stiff collotype ink, which may be thinned a little if necessary with a small quantity of collotype varnish applied on the slab. The ink should, however, be used

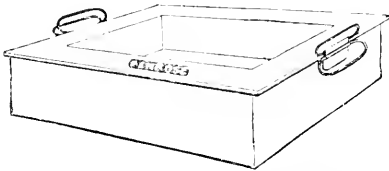

Fig. 889.—WATER-BATH FOR WARMING BICHRIMATE SOLUTION.

as stiff as possible. After well mixing with a palette knife, a small portion is taken on the point of the knife, and smeared in a line along the inking board. The nap roller is then started on the ink, pushed across the board, and raised and brought back again, this process being repeated until the ink is distributed in a thin, even coating all over the board and over the roller. The inked roller may now be applied to the plate, beginning with a slow, steady pressure, until the ink takes. The composition roller is then applied, with a quicker motion and lighter pressure. This will clean off the surplus ink and bring up the detail of the picture. It is possible so to regulate the pressure and speed in inking that the result obtained may be appreciably modified at will. A proof is now pulled (that is, a trial impression is taken) to see whether the damping and inking have

been satisfactory. If this is not the case, either or both may be repeated, in the former instance first washing off the ink with turpentine.

MISCELLANEOUS HINTS.

New rollers will not work well until they have been in use for a short time. The ink should be carefully wiped or scraped off the rollers before putting them away, and they should be occasionally cleaned with turpentine. The plate should also be cleaned after use by first rubbing very gently with turpentine and then with a clean sponge and water. The margins of the plate, if they do not print clean, may be painted with a weak solution of potassium cyanide, or with strong hypo.; strips of oiled paper can be used to mask the edges if only a few copies are required. The room in which collotype printing is done should be kept at an equable temperature and free from extremes of dryness or moisture.

THE SINOP PROCESS.

The Sinop process, patented by Penrose and Company, is a simplified form of collotype, giving very beautiful results. Specially prepared plates are supplied, which only require sensitising in a bichromate solution and drying by heat, the box containing the outfit being constructed to form an efficient drying oven. Exposure, development, and washing are practically the same as for ordinary collotype. The plate is then dried and immersed in water for two minutes before being placed in a glycerine solution, remaining in the latter for fifteen minutes. The surplus moisture is now removed with a soft sponge, followed by blotting paper, when the plate may be laid in an ordinary letter-copying press and printed from. A frisket, or mask of parchment paper, is cut, a little larger than the size of the picture, to prevent the ink setting off on the paper at the margins, the plate being inked in the usual manner with a roller as already described. Many of the difficulties inherent in ordinary collotype are successfully overcome by this process, which is

remarkably easy and sure in operation, providing that ordinary care is used.

COLLOTYPE WITH DRY PLATES.

In a process described by Liesegang some years ago in "Photography," plate glass was coated with a gelatino-bromide emulsion, and the resulting dry plate exposed behind a negative. For development the following formula was used:—

Sodium carbonate	20 parts
Water	400 parts

to which, just before use, 1 part of dry pyrogallie acid was added. Fixing and washing are as usual, after which the plate is brushed over with

Calcium nitrate	5 ozs.
Water	10 ozs.

The mixture is allowed to remain on the plate for about half an hour, when the surplus moisture is removed with a sponge and the plate may be inked up. The moistening operation is repeated from time to time as required. Various other means have been suggested for utilising ordinary dry plates, but all suffer more or less from the defect that the film is liable sooner or later to leave the glass under the strain of inking and printing.

PHOTO-LITHOGRAPHY.

In photo-lithography a print is obtained on a bichromated transfer paper, the image on which is inked and transferred to a lithographic stone. It is best to purchase ready-prepared transfer paper, which only requires sensitising; but for those who prefer to make their own the following formula is given:—

Nelson's No. 1 gelatine	2 ozs.
Ammonium bichromate	3¼ drs.
Water	8 ozs.

When the bichromate is dissolved, and the gelatine well saturated, insert the vessel containing these in a jar of hot water till the whole becomes of a thin fluid consistency. The mixture is now filtered before it has time to become cold, and is applied to a suitable rolled and sized paper while still moderately warm.

SENSITISING READY-PREPARED PAPER.

If, however, prepared transfer paper is obtained as recommended, it is merely sensitised in a bichromate solution made as follows: Dissolve 1 oz. of potassium bichromate in 20 ozs. water in a bottle, and add just as much ammonia as will suffice to turn the solution to a light yellow colour, when examined by looking through. The solution will keep, and if the colour changes, a little more ammonia is added. Filtering is advisable before use. For sensitising, the temperature of

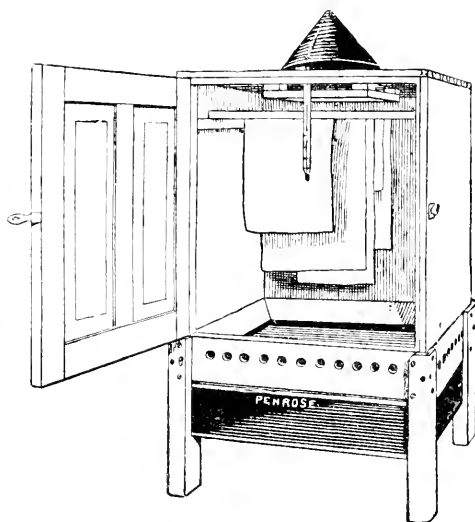

Fig. 890. — DRYING OVEN FOR TRANSFER PAPER.

the mixture should not be higher or lower than about 60° F., so that in winter a water bath of the shape shown by Fig. 889 is useful, the outer vessel being filled with slightly warm water. The transfer paper is placed in the solution, film side up, and allowed to remain for about one minute, or until the surface seems soft and the paper appears saturated.

DRYING SENSITISED TRANSFER PAPER.

On being taken out of the bath, the paper may be drained and hung up by clips in a dark room with sufficient ventilation. For fine work, however, it is preferable to squeeze it to plate glass,

allowing it to dry on the glass and stripping when dry. For ordinary purposes, except in hot weather, the sensitised paper will keep good for two or three days: but for work with fine detail it is better to use it within the same day. A drying oven of the pattern shown by Fig. 890 is very useful for drying quickly, but the temperature should on no account exceed that required to promote a slightly warm current of air, actual heat being avoided. If the paper is squeegeed to glass, it should first be thoroughly drained.

PRINTING AND INKING-UP.

A printing frame of the box pattern, with strong springs, should be used to



Fig. 891.—VELVET ROLLER.

ensure perfect contact, the paper being filled in in yellow light or gaslight. The negative must be a bright black and white one, on wet collodion or photo-mechanical dry plates, and free from flaws or scratches. Printing may either be examined during progress, or judged by actinometer. The next proceeding is the inking-up, which should be done in a room of even temperature. For this purpose transfer ink is used, the ink being well distributed over a stone ink slab with a lithographic leather roller, a velvet roller (Fig. 891) being then employed to take up sufficient ink from the slab. If too stiff, the ink is thinned with a little poppy or almond oil, thoroughly mixing with a palette knife before using; if too thin, some stiff lithographic ink must be added. The dry print is rolled with the velvet roller until it appears of an even light grey tint: it is then placed in cold water. Another method of inking-up is to thin the transfer ink with benzole and turpentine, applying the mixture with a tuft of cotton-wool, or the leather roller alone may be employed. An inking-up

board (Fig. 892) is of great assistance for holding the paper steady during the operation.

DEVELOPING THE TRANSFER

A rather deep zinc tray is useful for soaking the paper after inking-up. When the inked transfer has been in the water for about a quarter of an hour it is taken out and placed on a sheet of glass or other flat surface, the superfluous moisture being then lightly blotted off. A second velvet roller, uninked, is now passed over the print, removing most of the unnecessary ink, and leaving only the image. Any remaining ink is very gently taken off with a soft wet sponge, applied with a circular motion. If the ink does



Fig. 892.—INKING-UP BOARD.

not come away easily, the print is returned to the water for a longer immersion. When development is finished, the prints are pinned to a flat board and allowed to dry, or placed in a drying oven as previously described. For half-tone transfers a tuft of cotton is preferable to a sponge for removing surplus ink.

TRANSFERRING TO STONE.

This is done as in the ordinary method of lithographic printing. The print is wetted by placing it in a damping book, the film side being covered with thin, smooth paper. The transfer is then laid on the stone, a sheet of cardboard being placed over it, and on that a perfectly smooth sheet of thin zinc. The stone, transfer, etc., are then passed through the press, at first with but little pressure, which is afterwards increased if necessary. The paper is then removed, and should leave the whole of the ink on the stone. If the paper shows any reluctance to

come away, it may be damped on the back and again passed through the press. If too much pressure is applied, what is known as "squashing" of the image will occur. When a satisfactory transfer is obtained, this may be inked and printed from as in ordinary lithography.

DIRECT PHOTO-LITHOGRAPHY ON STONE OR METAL.

Instead of using a transfer, many workers prefer to obtain a print direct on stone, better results being claimed for this method. Bichromated albumen, or a solution of bitumen, is applied to the stone, as described elsewhere (see pp. 697 and 698), printing, development, and inking-up taking place in the same manner as directed under the respective processes. A slight etching is then given, to clean up the work, and this is followed by the usual lithographic procedure of printing. This method is also applicable to plates of zinc or aluminium. A reversed negative is necessary.

PHOTO-LITHOGRAPHIC TRANSFERS ON ZINC.

The inked transfers are well covered with a mixture prepared as follows:—

White resin	1½ ozs.
Syrian asphaltum	1 oz.
Yellow wax...	¼ oz.

These ingredients are melted in an enamelled saucepan, and, having been well mixed, are poured out to cool. The compound is then finely powdered and passed through a sieve. The transfers having been treated with the prepared powder, the surplus is dusted off with a tuft of cotton-wool. The prints are then held over a spirit lamp, film downwards, until the powder melts, the dull brown colour turning to a glossy black. The next proceeding is to immerse the prints in a rather weak solution of alum for about a quarter of an hour. After this they are washed in water and blotted off between sheets of moistened blotting paper. The zinc plate is now made as hot as the hand can bear it, the transfer is laid face down upon it, a suitable backing of stout

damped paper and "fronting blanket" is placed above it, and the whole is run through the press several times with gradually increasing pressure. The transfer is then damped at the back, and again run through with greater pressure. The paper is finally well moistened from the back, and should come away readily, leaving all the ink on the metal. When cold, the latter may be etched.

PHOTO-ZINCOGRAPHY.

This term is applied to the making of zinc blocks for printing, either by the method just described under photo-lithography, or by direct transfer, to the preparation of half-tone relief blocks on zinc, and to the reproduction of drawings executed on a specially prepared paper which can be transferred to that metal and etched. Zinc blocks are principally used for line subjects, copper being preferred for the better class of half-tone work. The metal should be of the best quality, and free from lead or other impurities. The finest zinc for etching purposes comes from Spain and is prepared in France. For common or unimportant work a cheaper variety is often used. The great disadvantage of zinc is that it will not stand heating to any great extent, becoming soft, crystalline and brittle, so that it is preferred to use it only in those processes where much heat is not required.

THE HALF-TONE PROCESS.

In the half-tone process the picture is broken up into minute and almost invisible dots by the interposition of a finely ruled cross-line screen between the copy and the plate in making the negative. The process receives its title from the fact that it is capable of rendering the half-tones and gradations of the original photograph upon zinc or copper blocks by a varying arrangement of dots. Since the half-tone block is of equal level throughout, while the ink is of one uniform depth, it is evident that the different gradations of light and shade must be represented in some special manner, for

the metal plate will not, like the collotype film, attract and repel the ink in a greater or lesser degree on the various tones of the picture. This difficulty is successfully solved in the half-tone process by the dots being automatically formed smaller and further apart in the lights of the picture, becoming larger and closer together in the darker portions.

THE RULED SCREEN.

The screens now generally used are of glass, ruled with a network of lines cross-



Fig. 893.—MAGNIFIED APPEARANCE OF HALF-TONE SCREEN.

ing at right angles, having, of course, transparent squares between the intersections of the lines. It is these transparent squares which help to form the dots, as will be presently explained. Fig. 893 shows how such a screen would appear if highly magnified. At one time, screens with only a single set of lines were used, these being turned a quarter round during the exposure to obtain the cross-line effect, but this was found unnecessarily troublesome. Wire gauze, silk net, and other materials have also had a

certain vogue, and been finally rejected. Screens formed of dots instead of lines, or composed of a chess-board pattern, have been tried experimentally, but have not achieved any great popularity. In Wheeler's Metzograph screen a very fine prismatic reticulation is secured on a plate of glass by the sublimation of, it is said, pyrobutelin, the glass being then etched with hydrofluoric acid. Excellent work has been done with the latter, but at present the ruled cross-line screen holds the field.

CHARACTERISTICS OF THE RULED SCREEN.

These screens, which were at first enormously expensive, because they were ruled by hand—a process that demanded such skill as few men were able to acquire—are now ruled by machinery with a diamond point, the lines being afterwards deepened by etching with hydrofluoric acid, and the furrows so formed filled in with a black pigment. Two screens are ruled in a similar fashion, placed face to face with the lines crossing, and sealed together with Canada balsam. Half-tone screens were formerly duplicated by photography on collodion plates, but this is not now done. They can be obtained of different spacing, or fineness of ruling, to suit the particular class of work to be undertaken, from 50 to 400 lines to the inch. The following are standard rulings, generally procurable without difficulty: 85, 100, 120, 133, 150 and 200. The finest work is, of course, done with the finer screens, a ruling very suitable for the generality of all-round purposes being that of 133 lines to the inch. The screens should be treated with great care, kept perfectly clean, and stored in a special box or case when not in use.

FORMATION OF THE DOT.

It is difficult to explain why the ruled screen, placed a short distance from the plate, should break up the image into dots of different sizes in the various parts of the picture. There have been many theories brought forward to account for this, but little is known with any

certainty. There is, however, a certain analogy between the action of any single opening in the screen and that which takes place in the case of a pinhole camera, which may make it easier to understand the operation of the former. For the sake of argument, suppose the numerous clear spaces of glass between the rulings of the screen are considered as so many pinholes, the diaphragm of the lens forming the source of light, or object. It is clear that each of these tiny openings will form a minute image of the diaphragm on the plate at the back of the screen, thus making a number of minute spots of light which form black dots in the negative.

SIZE OF DOT AFFECTED BY AMOUNT OF LIGHT.

As, however, when the picture to be copied is in front of the lens, the amount of light passing through the diaphragm will not be the same all over the plate, but will, of course, vary with the different shades and tones present in the copy, it seems not unreasonable to suppose that the size of the dots is affected according to the greater or lesser amount of light passing through the screen to form them. In other words, the minute spot of light falling on any portion of the plate through a single opening of the screen forms, as it were, a nucleus of light-affected silver reducible by development, which will increase or decrease in size according to the actinic value of the light. This may or may not be the true explanation: it is, at any rate, a good working hypothesis.

THE STOP AND ITS INFLUENCE ON THE DOT.

Still bearing in mind the similarity of action between each opening of the ruled screen and a pinhole camera, it does not require much consideration to see that the shape of the diaphragm aperture will materially affect that of the dots formed, since the dot is in effect a tiny image of the diaphragm, although modified in shape by various optical and other causes. Many different shapes have been proposed from time to time for the stop, of which

Fig. 894 affords a few examples, but in practice it is found that a square placed with its sides at 45° to the lines of the screen, or a square with its corners extended to promote joining-up of the dots, gives the most satisfactory result. It may be useful in calculating exposure to remember that a square diaphragm has the same effective aperture as a round one whose diameter is equal to the diagonal of the square.

FINDING LARGEST PERMISSIBLE DIAPHRAGM.

The fineness of ruling of the screen, the extension of the camera, the distance of the screen from the plate, and the size of

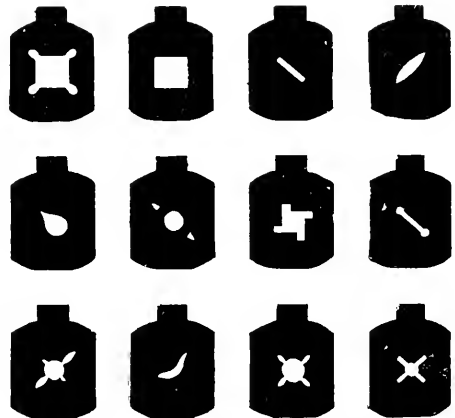

Fig. 894.—DIFFERENT SHAPES PROPOSED FOR HALF-TONE STOPS.

the diaphragm, are inter-dependent factors, and each must bear a certain relation to the others if the best results are to be obtained. The size of the largest allowable diaphragm in any given case may be found by multiplying together the width of the mesh of the screen and the camera extension, and dividing the product by the distance of the screen from the plate. The width of the screen meshes is, of course, half that of the number of lines to the inch: that is, say, with a screen of 100 lines to the inch the mesh is $\frac{1}{200}$ in. wide. Computation of these factors unnecessary

THE SCREEN DISTANCE.

The distance of the screen from the sensitive plate requires adjustment according to the camera extension and stop used, as already indicated; or else either the effect produced will be that of a network of lines instead of a dot effect, or the dots will not be sufficiently sharp. Provision for adjusting the distance of the screen is made in various ways in cameras for process work, as will be described later. The screen distance should

half-tone operations will be wise to obtain one of the several simple pocket-books now issued containing all the necessary tables. An ingenious appliance has recently been introduced by Penrose and Co., which indicates the correct screen distance for any camera extension. This is seen attached to the back and front of the camera in Fig. 902 (p. 692).

THE STUDIO.

The principles underlying the action of the half-tone screen having been explained, the studio and apparatus may

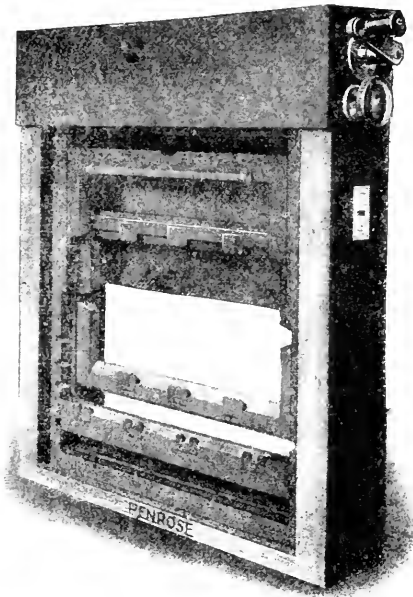

Fig. 895.—SCREEN AND PLATE HOLDER.

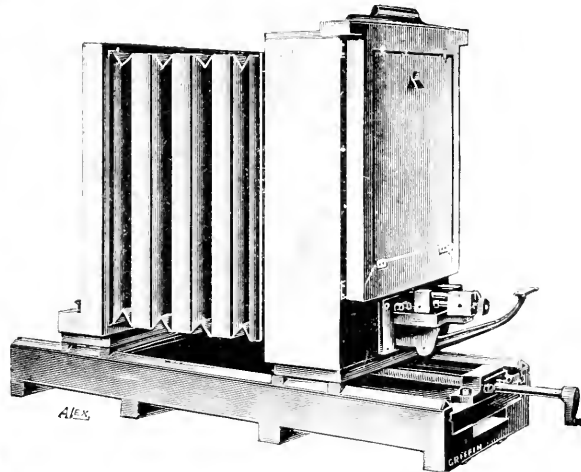

Fig. 896.—LINLEY PROCESS CAMERA.

be greater as the camera is extended, decreasing as the latter is closed up; it is greater with coarse screens, or screens having thin black lines, and less with fine screens, or those having thick lines; finally, the screen distance decreases as the size of the diaphragm increases, and *vice versa*. From this it will be seen that the correct screen were size and size of stop involve far too round calculation for practical work, across-line basis on which they may be necessary if desired has been indicated. net, and rker who desires to undertake

now be considered. Any studio designed for ordinary photographic work will be suitable; but, as the copy requires to be equally lit from both sides, the ideal arrangement would be one with a large skylight inclined towards the north, and glazed on the east and west sides, the picture to be copied being placed at the south side. Owing to the uncertainty of daylight, many workers (especially in towns) constantly use the arc light, which renders a specially constructed studio unnecessary. The preferable course, however, if it can be done, is to have a studio available for both daylight and electric light at will. In any case, it is requisite that the place selected should be free from vibration (although this may be



MAORI WARRIOR.

R. B. Walton.



GOLFING STUDIES.

E. Banbury.

overcome, if not excessive, by suspending the camera and copy in a swing bed, or by supporting it on springs) and of sufficient size for the camera extension and free movement of the operator. If electric light is to be used, the studio should be sufficiently high to accommodate the traversing gear of the arc lamps, unless these are worked on floor standards. Proper arrangements should be made for heating and ventilation. The developing and other operations are

patterns, with different devices for adjusting the distance between the screen and the plate, are procurable, one of the best of these being the Penrose holder (Fig. 895), which is made either with ordinary carriers for dry plates, or with adjustable bars, as shown in the illustration, to take wet plates, the screen distance being regulated by a knob outside, and indicated by a pointer moving on an ivory scale. This is, of course, a great advantage, many of the older forms of

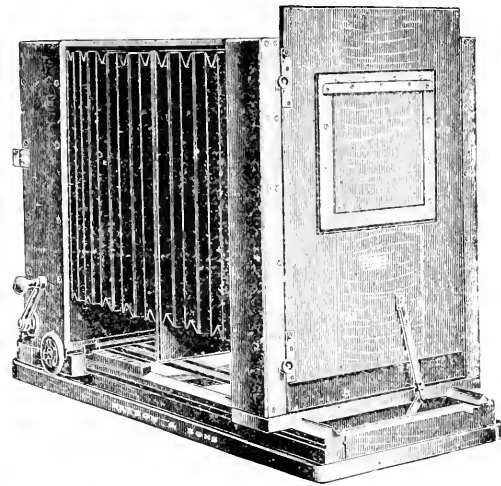

Fig. 897.—WATSON'S PROCESS CAMERA.

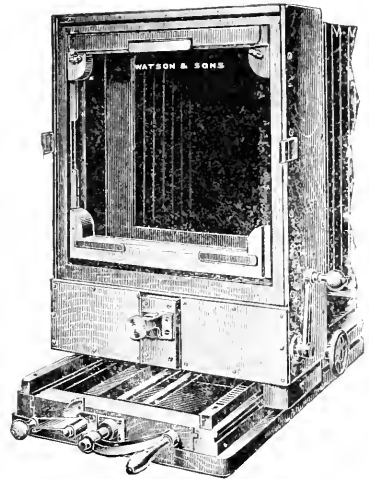

Fig. 898.—BACK VIEW OF WATSON'S PROCESS CAMERA, SHOWING SCREEN GEAR.

best done in a separate room or rooms, conveniently adjoining the studio.

holder requiring the opening of the slide, as well as its removal from the camera, before the screen distance could be altered.

THE SCREEN AND PLATE HOLDER.

THE CAMERA AND ACCESSORIES.

Although the primitive plan may be pursued of using an ordinary camera, placing the screen in the dark slide with strips of cardboard or wood to keep it the necessary distance from the plate, this would nowadays be regarded as simply an inconvenient makeshift. A beginner will, however, be able to secure fairly good practice by this means. Trial sizes of screens, which are small pieces left over in cutting up larger plates, are obtainable for experimental purposes. The larger sizes are necessarily expensive. Screen and plate holders of various

A better and more convenient plan adopted in all the latest process apparatus is to have the screen carried separately from the dark slide in a travelling frame actuated from outside the camera. There are various designs for the purpose, some of which are adjusted by the movement of a lever, others by a milled knob or a wheel. They are generally provided with a graduated scale to enable the exact screen distance to be read off, and with a micrometer screw for fine adjustment

Fig. 896 shows the Linley camera, in which the screen holder is held upon a dovetailed slide moved to and fro by a central lever. Above the latter will be noticed the micrometer screw, which supplies the fine adjustment. The camera used for process work should be perfectly rigid, and with all its parts truly parallel. It is an advantage if movement is

THE BASE AND COPYBOARD.

A suitable camera having been obtained, it is essential to provide satisfactory means of overcoming vibration, if there is any likelihood of its occurring. This may be accomplished by having a swing bed suspended from the roof, as shown by Fig. 900, or by having a cradle

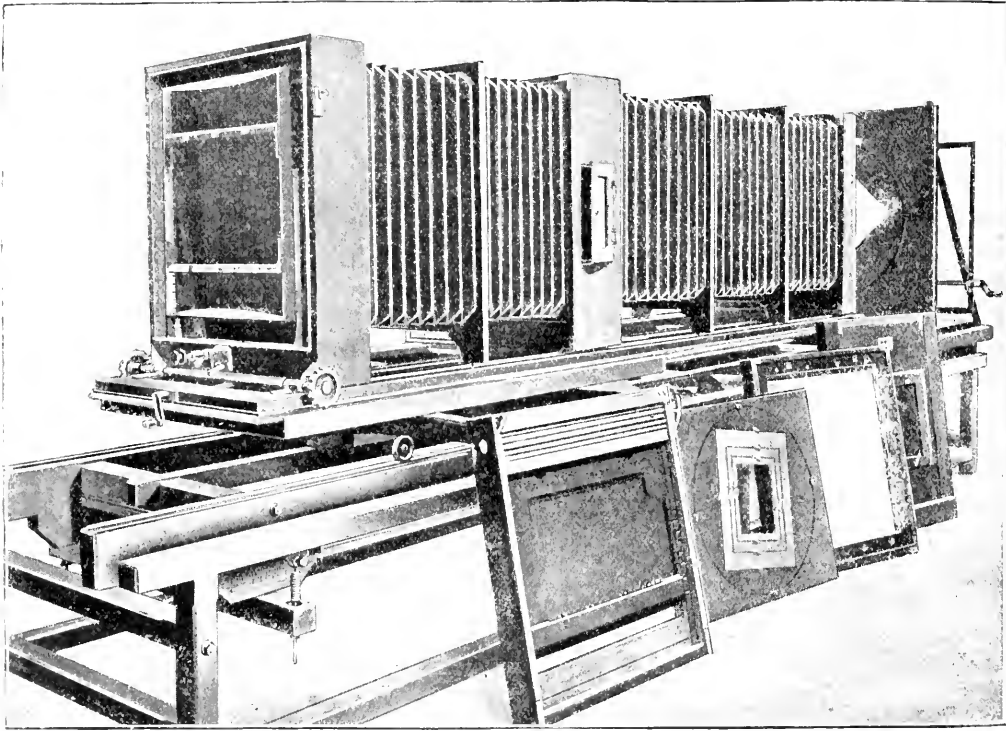

Fig. 899.—REPRODUCTION CAMERA WITH TRANSPARENCY EXTENSION.

arranged for from both back and front, with the control of both motions at the back within reach of the operator. In some of the more expensive apparatus mechanical adjustments are even provided for raising or lowering the front, shifting the lens, copyboard, etc., all from the back of the camera. Figs. 896 to 899 illustrate typical designs of process cameras, and give a good idea of the solidity of construction necessary. The reproduction camera shown by Fig. 899 is well adapted for large work.

base on springs (Fig. 901). If, however, the studio is in a quiet place, a rigid stand resting on a floor of concrete will meet every requirement; while even a wooden floor may serve if pads of rubber or felt are placed under the legs of the stand. The easel should be perfectly level and true, and may either be fixed at the end of the base frame or slide to and from the camera. It is a good plan to cover it with a thin layer of cork to facilitate pinning up the copies, and it is recommended to paint it a dead black. A convenient form

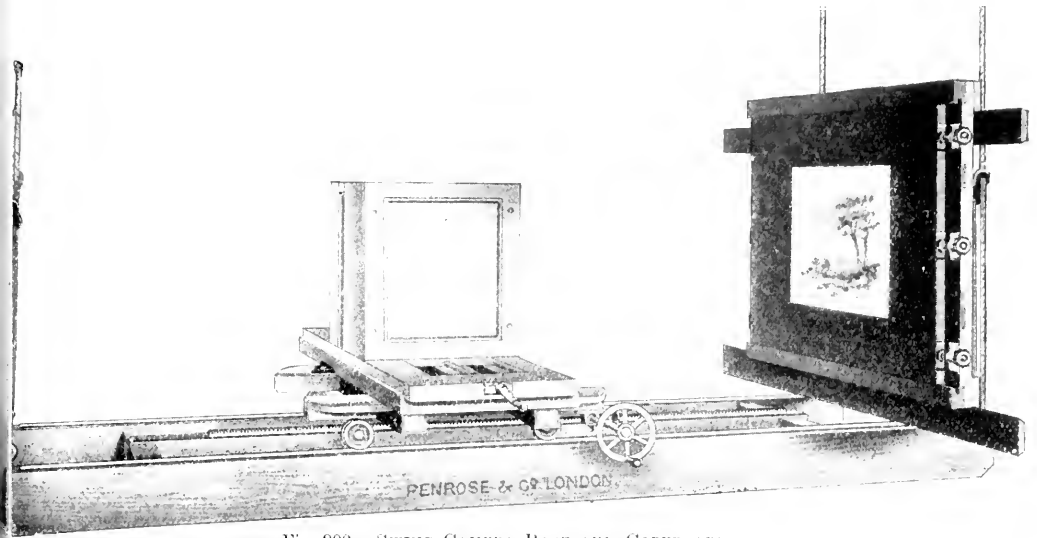

Fig. 900.—SWING CAMERA BASE AND COPYBOARD.

of stand for use with a mirror or prism and a fairly short focus lens is shown by Fig. 902. In this, it will be seen, the easel slides up and down the front of the stand.

This is obviously useful for copying many things which would be awkward to fix on an upright easel, besides which a downward lighting is found to be very satis-

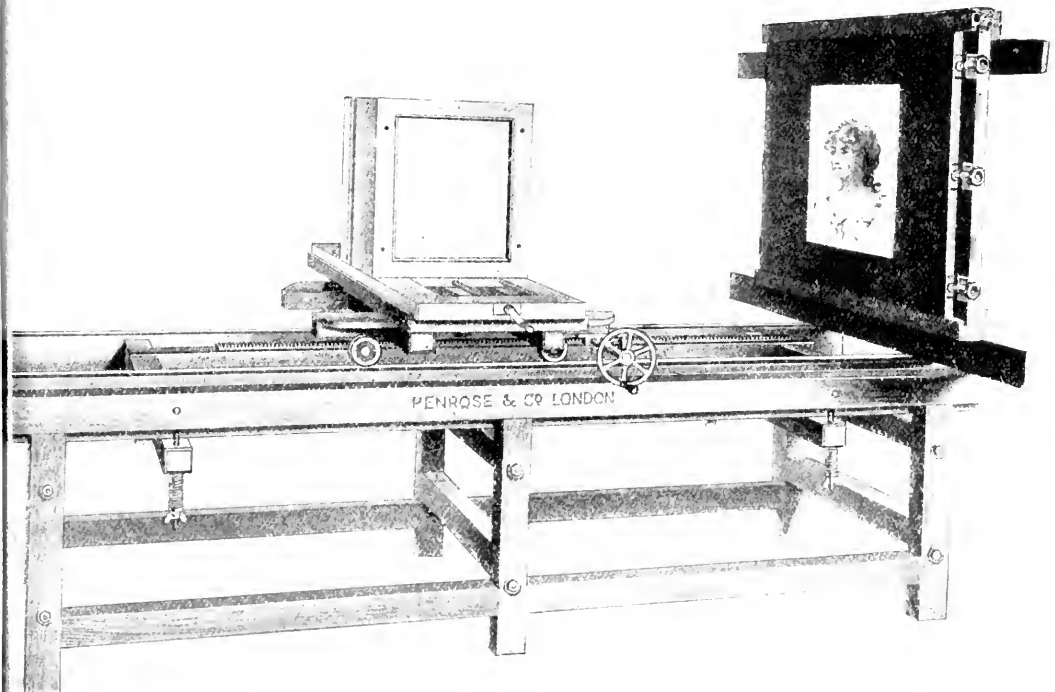

Fig. 901.—SPRING STAND FOR CAMERA AND COPYBOARD.

factory. It will be noticed that a glass shelf and a reflector are provided for photographing transparencies, etc.

THE LENS.

For process work the lens must be free from any form of distortion or aberration,

equal, and that it is not found convenient to have the screen so close to the plate as would be necessary with short-focus lenses. Another reason is that the rays of light pass through the long-focus lens at a narrower angle, which is found to be a desirable state of things for the formation of the dot. There are other arguments

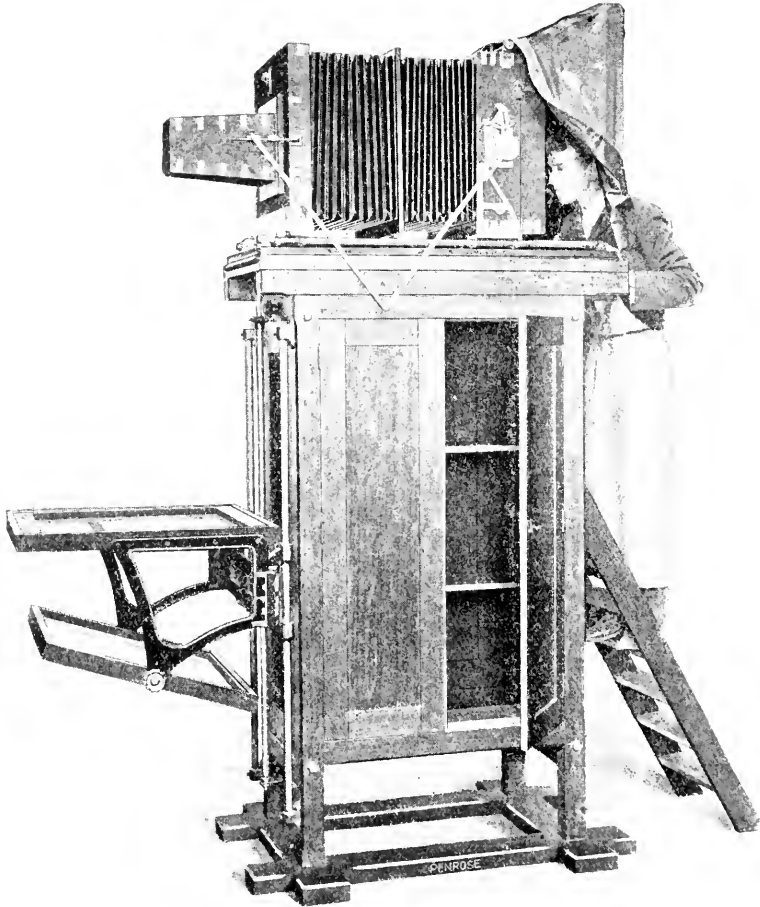
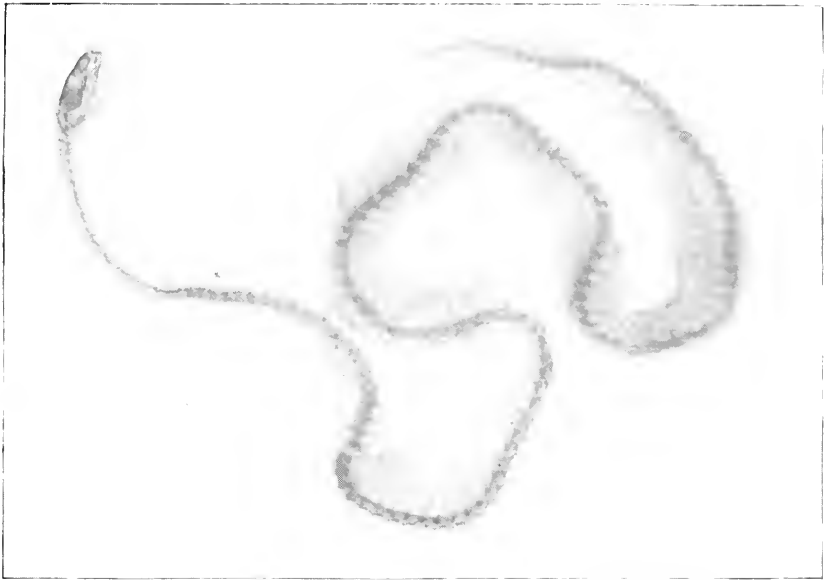

Fig. 902.—VERTICAL STAND WITH HORIZONTAL EASEL AND REFLECTOR.

of tolerably long focus, and of excellent definition and covering power with a large aperture. The reason for the lens having to be of long focus is that, as before explained, the screen distance depends on the camera extension, other things being

against the use of short-focus lenses, as, for instance, the fact that to obtain equally good definition to that possible with the long-focus lens the aperture will have to be smaller, with consequent loss of rapidity; and also the very grave



BONES IN AN ENGLISH ADDER



ORDINARY PHOTOGRAPH.



RADIOGRAPH

Photos : I. C. Hepworth.

LADY'S HAND WITH JEWELS.

objection that the short-focus lens does not work well with a prism. Any good anastigmat will answer well for process work, and many lens manufacturers

piece of the finest plate glass, silvered on the surface, and fitted in a triangular box at an angle of 45° (Fig. 903), thus enabling the lens to be used at right angles to the camera, the latter being placed sideways to the easel. The mirror is much cheaper than the prism, but requires far greater care, and is liable to

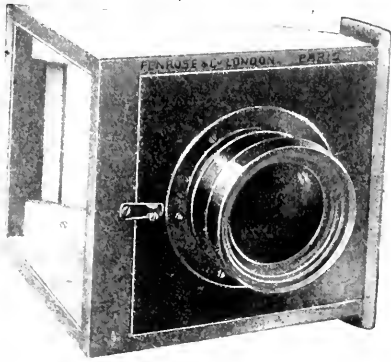

Fig. 903.—MIRROR BOX.

supply specially designed anastigmatic objectives for this purpose. The lens should have a slot in the mount for taking Waterhouse diaphragms and, preferably, an iris diaphragm in addition.

THE MIRROR OR REVERSING PRISM.

In order to get the final impression correct as regards right and left, the half-tone block has to be reversed, as a little reflection will show. In consequence, the negative must also be reversed, for which purpose a mirror box or a reversing

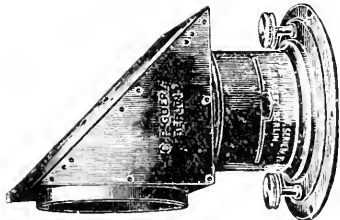

Fig. 904.—GOEZE REVERSING PRISM.

prism is commonly used, although in America a large number of workers prefer to strip the film of the negative. The mirror consists of an optically worked

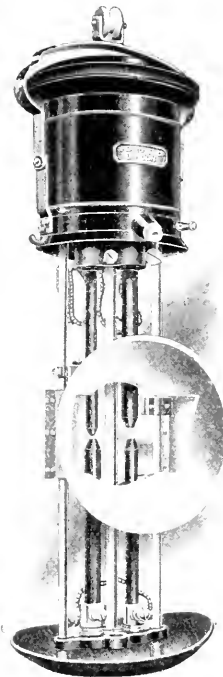

Fig. 905.

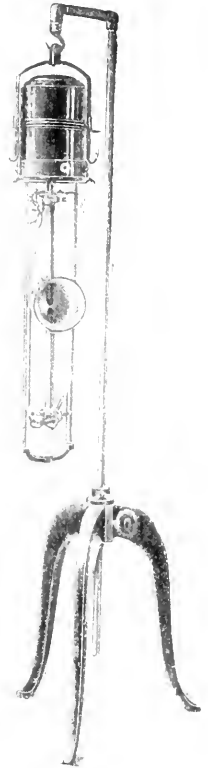

Fig. 906.

Fig. 905.—DOUBLE CARBON ARC LAMP.

Fig. 906.—ARC LAMP ON FLOOR STANDARDS.

tarnish and scratch, necessitating re-silvering—an expensive item, to say nothing of the stoppage of work involved unless several mirrors are at hand. With care, however, the mirror surface will keep in good condition for a long time. When it shows signs of tarnishing, it may be gently and gradually polished with the finest rouge and a tuft of cotton-wool. It should be put away in an air-tight case when not in use. Metal mirrors are now made, which are claimed to be much less

easily tarnished. The reversing prism is to be preferred if expense is no object, although it is said to be slightly slower. Fig. 904 illustrates the pattern made by Goerz.

ELECTRIC LIGHTING.

The electric supply is so largely dependent on special conditions, regarding the current available and the particular requirements of the user, that this detail is best left to the advice of a practical electrician. It is recommended that lamps specially designed for process work be obtained, since they will necessarily be much better adapted for the purpose than those primarily intended for some other use. An overhead traversing gear is an immense convenience if it can be had. Fig. 905 shows a good pattern of double carbon arc lamp by Penrose, adapted for hanging. Some workers, however, prefer lamps swung on movable floor standards, and this plan is certainly best if a traversing gear is out of the question. Fig. 906 illustrates a typical model. The rod has a raising and lowering movement, and the lamp may be swung round if desired. Whatever kind of lamp is employed, it should possess a self-focussing adjustment for the carbons; that is to say, both the carbons should move together. A lamp in which one of the carbons is fixed is extremely inconvenient, requiring continual adjustment of the lamp and reflector. Resistance or choking coils should always be obtained with the lamps correctly adjusted to suit them.

MAKING THE NEGATIVE.

The copy to be photographed is fixed upside down on the easel with drawing pins, and every precaution taken that the camera is properly parallel. The lighting must be so arranged that there are no reflections. If arc lamps are used, these must be placed at exactly equal distances from the copy on each side. A sheet of white paper laid horizontally below the copy is useful to throw the light upward and improve the illumination. Focussing is done with the ruled screen in the

camera, a magnifier being employed for examining the dot effect. The dots should join up in a kind of chess-board pattern, the correct and incorrect placing of the screen and stop being soon ascertained by a few trial negatives, after which no difficulty will be found. If only one diaphragm were used, the high lights of the negative alone would receive sufficient exposure for the rendering of the dot effect, the other parts of the picture being unsatisfactory. It is therefore necessary to give the plate a preliminary exposure on a sheet of white paper held before the copy, using a small round diaphragm. This, of course, results in the formation of isolated dots all over the negative, which fall into their proper place, as it were, after the exposure proper and development. The necessary exposure for the copy is now given, using a square stop.

FINDING THE EXPOSURE.

The correct exposure can only be ascertained by experience. That given for the shadows may be found by exposing a plate, as described, on a sheet of white paper only, and developing. The exposure proper, with the square stop, will be about five times as long as the copy would take to photograph under the same conditions, but without the screen. In some cases, as, for example, with flat or difficult subjects, a supplementary exposure may be necessary with the stop having extended corners, to promote better joining up; but with good originals this will not be required. Under-exposure should be avoided, slight over-exposure being preferable.

WORKING THE WET-PLATE PROCESS.

The details of the wet-plate process have already been fully dealt with in the section on Plates and Films, so that it will only be necessary to indicate the special points to be observed in process work. The collodion may be made as described on p. 74, or may be obtained

specially prepared for the purpose. A suitable formula for bromo-iodising is:—

Ammonium bromide	80 grs.
Cadmium iodide	80 grs.
Cadmium bromide	40 grs.
Alcohol (sp. gr. '810 to '815)	10 ozs.

This amount will be sufficient to 20 ozs. of collodion. The mixture should be allowed to stand for about a week before using. The details of cleaning and edging the plates, sensitising, etc., are

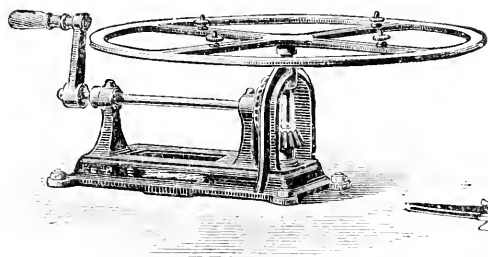

Fig. 908.—WHIRLER FOR TAKING PLATE FACE UPWARD.

essentially the same as given on pp. 75-79. A developing formula recommended is:—

Ferrous sulphate	210 grs.
Glacial acetic acid	4 drs.
Water	12 ozs.
Alcohol	4 drs.

This will require to be diluted when working with a fine screen. Fixing is done with potassium cyanide for preference, although hypo. may be used if desired

INTENSIFICATION AND "CUTTING."

It is usual to obtain greater density by re-development or intensification, either before or after fixing. Various formulæ for this will be found on p. 136. The lead ferricyanide and copper bromide intensifiers (p. 135) may also be used. Following the washing after intensification, the negative is treated in a reducing solution for the purpose of "cutting" or sharpening the dots—that is to say, clearing away any undesired deposit between them, and smoothing up their edges. This may be done with the ferricyanide and hypo.

reducer, or with iodine and potassium cyanide. The iodine solution is the same as that given for intensification on p. 136; this is flowed over the negative till it appears a bluish-green in the shadows. The plate is then rinsed, and a solution of potassium cyanide, 3 grains to the ounce, is poured evenly and rapidly over it. The iodine solution and cyanide may be mixed if desired, in which case the cyanide is poured into the iodine, a drop at a time, until the solution becomes transparent and loses its yellow colour. After cutting, the plate is rinsed and examined

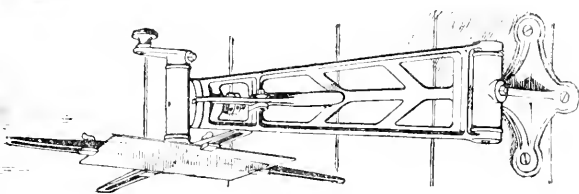

Fig. 907.—WHIRLER ON HINGED BRACKET.

with a magnifier, and if necessary again treated. The blackening is generally left till after the cutting, the operation of intensification being divided.

COLLODION EMULSION AND DRY PLATES.

Dry collodion plates are dealt with on pp. 82-83. The necessary after-treatment is the same as for wet collodion. Ordinary dry-plates are a good deal used, especially by those workers unfamiliar with the collodion processes; they should be of the photo-mechanical or process variety. The chief difficulty with emulsion plates of any kind is to avoid spreading of the dots. There may be various reasons for this, but backing the plate, as a preventive of any spreading due to halation, is obviously a wise precaution. Some workers recommend a lesser screen distance and smaller stops, as helping to improve matters. Although the wet-plate process at present holds the field, it must be admitted that the process dry-plate is rapidly gaining in favour, and that with the latter a good operator can produce results which do not suffer by comparison with those obtained by other methods.

SENSITISING THE METAL.

After sufficient washing, the plate is allowed to dry, or is dried by a gentle heat if wanted quickly. If intensified with copper, it will require varnishing first, or the copper will chemically affect the bichromated film used in printing. Varnishing is done by flowing a weak solution of gum arabic over the plate while wet. Printing is now generally executed by the enamel or fish-gum process. The copper or zinc plate is thoroughly polished with a paste of whiting, to which a few drops of ammonia is added, applied with a tuft of cotton-wool. It is then coated with a bichromated solution of fish glue. There are various formulæ for this, but the following is well recommended:—

Le Page's fish glue (clarified) ...	2 ozs.
Water	2 ozs.
Ammonium bichromate	50 grs.

The bichromate is first dissolved in the water, and then added to the glue, and is stirred vigorously till perfectly mixed. The mixture is then filtered through a piece of thick felt. A whirler is commonly employed for coating. This is a device for rapidly and evenly distributing the sensitising mixture over the plate, and drying it quickly. Some patterns are arranged to hold the plate face downward over a gas burner (see Fig. 907); others take it face upward as shown by Fig. 908. This is a very good plan, especially for large plates, but is more liable to collect dust on the wet film. A simple hand pattern of whirler is illustrated by Fig. 389, p. 271. The solution is poured in a pool on the centre of the plate, and spread over about three-quarters of the surface, leaving a little margin uncovered. The plate is then whirled by turning the handle of the whirler at a moderate speed, neither too fast nor too slow; about four revolutions of the plate per second will probably prove correct.

PRINTING ON THE METAL.

If the whirling has been done properly, the film will have extended to the edges

of the plate, and should be a glossy transparent yellow. The plate is now placed with the negative in a pressure printing frame, of which there are various patterns, first bringing them both to an equal degree of warmth and dryness. The correct exposure can only be learned by experience, aided by the use of an actinometer; from three minutes in the sun to about twenty minutes in the shade is a fair average. After exposure, the plate is soaked for half a minute in water, and a solution of methyl violet (1 in 20) is poured over it and allowed to remain for one minute. The object of this is to dye the film so that the progress of development may be gauged. Pouring the dye off, the plate is placed under gently running water until judged to be sufficiently developed. Development must be continued till the bare surface of the metal plate can be seen between the dots. A last rinse with warm water may be given, if considered necessary. The plate is now stood up to dry, or, if wanted at once, drained and immersed in methylated spirits for a few minutes, after which it will dry very quickly.

THE BURNING-IN.

This must not be confused with the burning-in operation employed in photo-ceramics, where an image composed of vitrifiable colour is fired on a porcelain or china support. The object in view in the present case is quite different, being simply to cause the organic matter of the image to form an oxidation product by exposure to sufficient heat: experience having shown that the oxidation product so obtained is insoluble in water and acids, thus enabling the metal to be etched in an acid bath while the image is unaffected. The plate is held in a pair of pliers or plate tongs over an open gas stove, the flame being in contact with the back, and moved to and fro to secure uniform heating. The image will first turn yellow, deepening to brown, and lastly almost black. When it has attained a deep chocolate brown colour, the plate may be removed and laid on a sheet of asbestos board to cool. Zinc blocks

require special care in heating. Various methods have been brought forward from time to time for dispensing with the burning-in, or enabling a lesser degree of heating to be employed, but the advantage gained is very slight. The dusting-on process has also been adapted for block-making.

ETCHING ZINC PLATES.

The plate is now cleaned by passing it for a few seconds through a very weak acid bath (nitric acid, 1 in 100) just sufficiently long to dull the surface. It is then rinsed under the tap, the adherent scum being removed with cotton-wool,

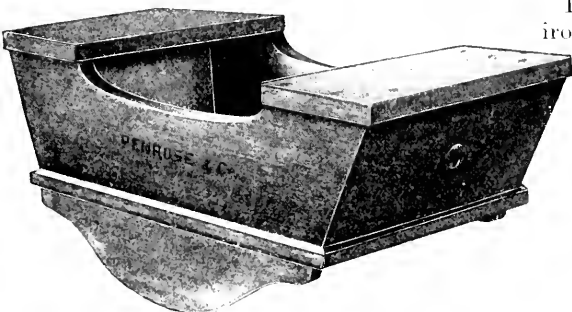

Fig. 909.—ETCHING TROUGH.

and dried at a gentle heat or by an air current. Any retouching, spotting, or ruling is next done with lithographic writing ink applied with a fine sable brush or a ruling pen, as the case may be. Scratchers, etching needles, and other tools, are used for clearing away black spots, making white lines, etc. Parts required to be white are scraped away, while those which have to be black are drawn or painted over. The back and margins of the plate are now varnished with a resist, generally consisting of shellac in spirit. When this is dry, the plate may be placed in the etching bath, which should preferably be a 1-per-cent. solution of nitric acid, although some workers recommend a stronger bath. With the strength mentioned, etching may take as long as thirty or forty minutes, during which time the bath must be regularly rocked. The disadvantage of the stronger bath is that it may possibly

soften the film or cause ragged dots. It is said to be a good plan to immerse the plate in a weak solution of chromic acid before etching, with the object of removing any granularity caused by the burning-in; this also expedites the etching process. Troughs of the kind shown by Fig. 909, with sloping, covered ends to prevent splashing, are very convenient; although in more elaborate arrangements the rocking may be done by motive power, a lever being provided for stopping the motion when required.

ETCHING COPPER OR BRASS.

For these metals an etching solution of iron perchloride is employed. This may be made by dissolving 3 lb. of the perchloride in a quart of hot water. It is usual to test the strength of the solution with a Beaumé hydrometer, about 35° being the strength most suitable for use. A weaker solution is undesirable, being more likely to affect the film. Etching takes from five to fifteen minutes, according to circumstances. Some workers prefer to lay the plate face downwards, supporting it with wooden clips, but this is largely a matter of taste. In any case no rocking is required. If the operation is slow, a very gentle brushing with a soft brush may be necessary, but this should be avoided as much as possible.

OTHER METHODS OF BLOCK MAKING.

In the albumen process, a zinc plate is first rubbed with fine pumice powder, and etched to a matt surface in a bath of nitric acid and alum. It is then coated twice with a bichromated albumen solution, and dried on a whirler at a gentle heat. After exposure under the negative in the usual manner, the plate is rolled up with a thin film of transfer ink. The turpentine is allowed to evaporate from this, and the plate is then immersed in water and gently wiped with a moistened piece of cotton-wool; when, if the exposure and other factors have been correct, the surplus ink will come away, leaving only the image. The plate is now

rinsed, dried, and dusted with powdered asphaltum, or resin, or with a mixture of resin, asphaltum, and pitch. After the surplus has been brushed off, the plate is held over the stove until the dull surface of the image becomes glossy. When the plate is cool, etching may take place, a nitric acid solution being employed as



Fig. 910.—STEEL BURNISHER WITH WOODEN HANDLE.

before described, but of rather greater strength. A red powder known as "dragon's blood" is sometimes used instead of asphaltum; in this case a stiffer ink is required, known as "American etching ink." The powder is brushed on as before, and the plate heated till the image assumes a deep brown colour. In a modi-



Fig. 911.—ROULETTE WITH FINE MILLING.

fication of the albumen process, known as the blue process, the plate is sensitised with bichromated albumen, exposed under the negative, and flowed over with a special solution of aniline violet, chloroform, benzole, and alcohol, with mastic or asphaltum added as a resist. When the solvents have evaporated, the plate is developed in water, and, after drying, may



Fig. 912.—CROSS-LINE ROULETTE.

be etched at once with the nitric acid bath.

THE BITUMEN PROCESS.

This, the oldest photo-mechanical printing process, has been practically abandoned for half-tone work on account of its slowness and other disadvantages. A good formula for the sensitising solution is as follows:—

Purified bitumen...	150 grs.
Chloroform	2 ozs.
Benzole	2 ozs.
Oil of lavender	3 minims.

The bitumen is first dissolved in the chloroform, the other ingredients being then added. Coating is done with a



Fig. 913.—ROULETTE WITH MILLED LINES.

whirler. It is usual to dust the negative with French chalk to prevent the bitumen sticking to it during printing. Development is accomplished by flowing over with turpentine, aided, if necessary, by gentle rubbing with cotton-wool. When develop-



Fig. 914.—ROULETTE WITH DOTS.

ment is complete, the plate is washed under the tap to remove the dissolved bitumen, together with any greasiness or scum. After drying, any retouching is done, the plate being then heated to about 150° F., and allowed to cool. It is next etched for one minute in nitric acid, 2 per cent., rinsed, dried, and smeared over with thick gum. When this is dry,



Fig. 915.—ROULETTE WITH MEDIUM MILLING.

the plate is wiped with a moistened sponge, and rolled up with stiff lithographic ink. The etching is then finished with a stronger solution.

THE FINISHING ETCH AND FINE ETCHING.

With most of the processes described, it is commonly necessary, after the preliminary etching, to give a finishing etch to smooth and sharpen up the plate. The resist is removed with turpentine, paraffin, or methylated spirit, as the case may be.

and the plate thoroughly cleaned with a solution of caustic potash. After warming, it is then rolled up with finishing ink. When the image is sufficiently black, the plate is again warmed till the ink becomes glossy, and, after cooling, is etched for a couple of minutes in a rather weak bath. "Fine" etching is used for obtaining better contrast in flat or difficult subjects

previous operation, when probably the vignetting will be sufficient. In many establishments, however, vignetting is now done direct on the negative, by means of Holt's Vignetter, in which a serrated disc is made to revolve by clockwork between the lens and copy during the exposure.

ENGRAVING AND TRIMMING.

After etching, the plate is passed to the engraver for the removal of any black spots, for the making of white lines, and for putting in high lights, etc. It is in the engraver's power to improve the result greatly where the requisite time and labour is permissible. A good plate, how-

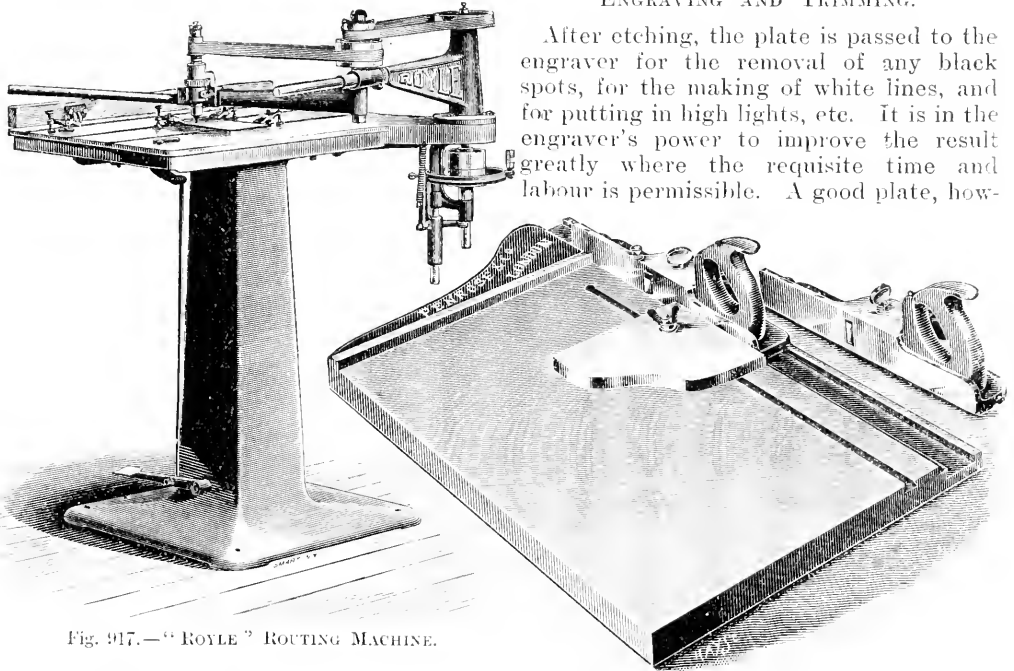

Fig. 917.—"ROYLE" ROUTING MACHINE.

Fig. 916.—SHOOTING PLANE AND IRON BED-PLATE.

by lightening parts which are too dark. This is accomplished by "stopping-out" the parts that do not require treatment with varnish or other resist, and re-etching the desired portion. Obviously this requires a certain amount of artistic taste. Vignetting is also done on the block, when necessary, by stopping-out the image to within about three-quarters of an inch of the required boundary, carefully softening or stippling the varnish at the edges with a hog-hair brush. The plate is then etched for one minute, then dried, and the varnishing and softening repeated, bringing the edge of the varnish a little nearer to the boundary of the vignette. Another minute's immersion in the etching bath is now given, followed by a repetition of the

ever, should require but little touching up. A light part of the block can often be made to print darker by rubbing with a highly polished steel burnisher (Fig. 910). Roulettes (Figs. 911 to 915) are employed for lightening dark places, by stippling the plate with tiny holes. These are also made with lines instead of dots, for breaking up line work and softening hard edges. The next step is to bevel the margins of the metal plates, so that the nails used in fastening them to the wood blocks may lie below the surface. In small establishments this is accomplished with a shoot plane working on an iron bed-plate (Fig.

916). Two planes are supplied with this appliance, one for trimming the wood block and the other for bevelling the metal. Where much work is done, special machinery, driven by power of some description, is employed for these purposes. In Royle's "lining beveller," an elaborate arrangement of this kind, provision is made not only for bevelling the plate but for mechanically engraving black or white lines, of any desired spacing and width, round the margin of the picture.

ROUTING.

This operation consists of cutting out pieces of metal or making hollows, where the block is required to print white; as in catalogue illustrations, trimming round vignettes, etc. This is done on a small scale with chipping tools, punches, and a jig or fret-saw. In large firms, however, a routing machine is employed, having a drill-like cutter which revolves at a high speed. The cutter may be either fixed, or attached to a "universally" movable arm; the latter plan being, of course, the most convenient. A typical router of the second description is shown by Fig. 917. Various kinds of cutters and drills are used which, as a rule, require sharpening on the edge only, a fine oilstone being employed for the purpose. When grinding is required, a wooden handle is necessary to hold the cutter.

PROVING.

It is better to take the final proof before mounting. The plate is laid in the press on an iron block to bring it up to type level, first cleaning it with turpentine and a soft rag, and seeing that there is no grit on the back. Stiff blue-black ink should be used, well rolled in with a composition roller. Smooth paper of good quality is necessary to obtain the best results. Several sheets of stout paper and a piece of thick indiarubber sheeting or of printers' "blanket" are laid over the proof sheet, and a strong pressure applied for a few seconds. On examining the result, it may be found that the shadows print too heavily, or that the contrast is

unsatisfactory. In either case, what is called an underlay has to be cut from the proof to the shape of the portions it is desired to modify, this being pasted to the back of the plate. Sometimes several layers of underlay may be necessary, each layer being cut a trifle smaller than the preceding one, and the edges scraped so as to taper down. This is particularly requisite in the case of vignettes. An overlay placed above the proof sheet may also be needed. This is cut or built up in a similar fashion to the underlay, and is of convex form. Various methods have been suggested for making the overlay or underlay, among others being an ingenious system of obtaining a relief image in bichromated gelatine from the negative used in making the block. The De Vinne-Bierstadt overlay shown at the 1904 Printing Trades Exhibition, at the Royal Agricultural Hall, London, appears to be based on a similar process.

MOUNTING.

All that now remains is to mount the block so that it will be type-high. Any remaining margin is trimmed off, and the holes for the nails are made with a sharp punch, the work resting on a leaden block. A drill is then employed to countersink the holes. The plate being held squarely on the block, the nails are tapped half-way in with a hammer, the driving being completed with a flat-ended punch and a mallet. Any necessary trimming of the wood block is now done with a circular saw and the shoot plane or trimmer, unless this has been undertaken before nailing on the block. The block is next tested with a suitable gauge to ascertain whether it is of the correct height, and any default in this respect is remedied by planing off sufficient wood or, if already too low, by placing a piece of paper or cardboard between the plate and the mount. If the plate has to be cut right up to the edge, for letting into a larger plate, nails cannot be used. In this case, screw bolts are soldered to the back of the plate, and fastened by nuts lying in recessed holes at the back of the wood block. The wood employed for



J. Guardia.

mounting is commonly oak or mahogany, and may, if desired, be purchased ready planed to suit a given thickness of metal. What is known as laminated wood is a recent introduction, consisting of several thin layers of wood glued together with the grain crossing. This is free from the tendency to warp, but, of course, more expensive than ordinary wood.

PHOTOGRAVURE.

Fox-Talbot was apparently the first to suggest the artificial production of a grained image by the use of powdered resin—the principle on which photo-gravure depends for its results. His method consisted of obtaining a relief image in bichromated gelatine, dusting this with the powdered resin, and making an electrotype from the grained relief. This process was greatly improved by Klic, who introduced the much better plan of applying the powder to a highly polished copper plate, making it adhere by the application of heat, and transferring a carbon print to the grained metal. This is then developed on the plate, and the resulting image, with its underlying grain, etched with ferric chloride.

OBTAINING THE PRINT.

It is a modification of Klic's process which is now generally employed. The negative used should be rather thin and full of gradation; one which will yield a good print on P.O.P. is very suitable. A reversed transparency must be made from this, either by copying the negative in the camera with the glass side to the lens, or by obtaining a carbon print on glass in black transparency tissue. From the resulting positive, which should be rather flatter and with less contrast than an ordinary lantern slide, a carbon print is to be made, preferably on special orange tissue sold for the purpose. While this is printing, the copper plate may be got ready.

GRAINING OR DUSTING.

The copper plate should have bevelled edges and a perfect polish, free from

scratches. Suitable plates are obtainable ready prepared. A dusting box is required to hold the powder, which may be either resin or bitumen. The latter is, at present, more generally used. The box should be about twice as high as it is long, and it should be supported by trunnions or projecting rods at each end, on which it can be turned round. The bottom should be considerably larger than the size of the plate, at one side being a door by which the latter can be inserted. A quantity of finely powdered bitumen, say about a pound, is placed in the box, and the latter is turned over and shaken several times to disturb the dust; it is then left to stand for about half a minute to allow the coarser grains of bitumen to settle. The plate is now inserted, and allowed to remain till the dust has covered it, the door being meanwhile closed.

DEVELOPING, ETCHING, ETC.

When the plate is considered to be sufficiently dusted, it is carefully withdrawn, and heated over a Bunsen burner. The heat applied must be only just enough to melt the bitumen, and cause it to adhere to the plate; on no account must the melted dust be allowed to run together. The carbon print from the transparency is now developed on the grained plate. When this is washed and dried, the edges and back of the plate are protected with bitumen varnish, or other suitable resist, and the etching can be proceeded with. Five solutions of ferric chloride adjusted to the following strengths with a Beaumé hydrometer—36°, 35°, 40°, 43°, and 45°—are required. These must be used at a temperature of about 75° F., the room being also kept warm. The strongest solution is first allowed to act on the plate for about one minute, or until the shadow portions are etched. This is then poured off, and the solution of the next strength is employed; this being done in turn with each solution, finishing up with the weakest, until the highest lights commence to show indications of etching. The action must then be at once stopped by placing the plate in a

solution of caustic soda. After this, the plate is washed, and the bitumen removed with benzole, turpentine, and methylated spirit. It is now ready for inking-up and printing from.

THE WOODBURYTYPE PROCESS.

In this process a relief negative is made in bichromated gelatine, and from that a metal intaglio or mould is obtained by heavy pressure. Melted pigmented gelatine is poured into the mould, the paper laid down on this, and pressure applied, when a picture exactly reproducing the gradation of the original is secured, formed by the different thicknesses of pigmented gelatine; the relief, nevertheless, being so slight as to escape notice. A specially bright and vigorous negative having an edging or safe edge is required. For the relief plate, sheets of plate glass are well cleaned with French chalk and coated with plain collodion. When perfectly dry, the sensitised tissue is poured on. There are various formulæ for this, the following being very suitable:—

Nelson's sheet gelatine	1 $\frac{3}{4}$ ozs.
Glycerine	50 minims
Sugar	$\frac{1}{2}$ oz.
Indian ink	1 gr.
Carbolic acid	1 minim
Ammonium bichromate	150 grs.
Ammonia	30 minims
Water	6 ozs.

The gelatine is soaked in three-fourths of the water, and melted by heat, the glycerine, sugar, carbolic acid, and ammonia being then added. The Indian ink is dissolved in the remaining water and added gradually, and the bichromate, well powdered, is finally stirred in. The temperature of the solution should be raised to about 140° F., when the warmed and carefully levelled plates are coated by pouring a sufficient quantity of the mixture on, from a warm measure, and spreading it over with a glass rod or by tilting the plate. About half an ounce will be sufficient for a quarter-plate. The plate is then rapidly dried.

EXPOSURE AND DEVELOPMENT.

The exposure and development are the same as with carbon printing. Hot water is used in a vertical bath, the plate being allowed to develop spontaneously. The temperature should not be higher than 110° F. to commence with, and the water should be changed at intervals; but when the bichromate salt is entirely dissolved out, the heat may be raised to about 160° F. The operation will take time, seldom less than a couple of hours being required, and often very much longer. Development should be carried on until the high lights of the picture are all but dissolved away. The plate is then rinsed in cold water, and immersed in a solution of chrome alum (4 per cent.). It is again washed, drained, left in a dish of pure methylated spirit for one hour, and then dried.

OBTAINING THE METAL MOULD.

The film is now stripped from the glass, and the relief side is covered with a lead plate. The two are then pressed together in a hydraulic press, which instead of damaging the gelatine image, as might be expected, produces a reverse or mould in the metal. The intaglio mould so obtained is placed in a press, melted pigmented gelatine of a suitable colour and depth is poured upon it, and a sheet of paper, which must be strongly sized, is laid over it. A flat glass platen is now brought down on the whole and held tightly in position. The superfluous solution is forced out by the pressure, while that in the mould adheres to the paper. After the gelatine has had time to set, the platen is lifted and the paper withdrawn. Finally, the print is immersed in an alum solution to harden the gelatine.

THE STANNOTYPE PROCESS.

Mr. W. B. Woodbury, the originator of the process previously described, afterwards modified it so that the hydraulic press was rendered unnecessary. The gelatine relief, supported on plate glass, or any suitable level surface, was covered with tinfoil, the two being passed

together through a rolling press having indiarubber rollers. This pressed the tinfoil into the interstices of the relief, producing a perfect counterpart. Copper was then electrically deposited on the tinfoil to strengthen it, and a glass plate coated with resinous cement was attached with pressure to the copper. This is known as the Stanotype process. A later modification of this consists of using the gelatine mould itself for printing from, and coating it with tinfoil to preserve it. A gelatine intaglio instead of a relief is then required, printed from a transparency instead of a negative. A thin solution of indiarubber in benzine is used for cementing the metal to the gelatine.

GELATINE RELIEFS FROM DRY PLATES.

The following method will give a good amount of relief for the Woodburytype process, provided a very thickly coated plate is employed. A rather full exposure should be given, and the subjoined developer used:—

	No. 1.		
Pyrogallic acid	60 grs.
Water	10 ozs.
	No. 2.		
Potassium hydrate	240 grs.
Sodium sulphite	240 grs.
Water	4 ozs.
	No. 3.		
Potassium bromide	240 grs.
Water	4 ozs.

For use, take 1½ oz. of No. 1 and ½ oz. of No. 2, and develop the plate in the mixture till sufficient detail is apparent, then add 20 minims of No. 3, and continue development till the density is satisfactory. After this, well wash the negative, and place it in a warm 10-per-cent. solution of chrome alum (about 95° F.), gently brushing it with a soft camel-hair brush while it is in the solution. When enough relief is secured, wash thoroughly, and fix in hypo. If the plates are found to show any tendency to frilling, this may be avoided by coating the edges with indiarubber solution.

OTHER PHOTO-MECHANICAL PROCESSES.

There are a large number of variations on one or other of the processes previously described. In some, a relief image, as in Woodburytype, is obtained in gelatine, with which has been incorporated powdered glass or similar material, thus producing a grain; in others, an electrotype is made from the relief and treated in different ways to obtain a similar result, or even printed from without further treatment. In Obernetter's process, a positive is made on a gelatine plate rich in silver, and the resulting image converted into silver chloride by a mixture of iron perchloride and chromic acid. This film is brought in a wet state into contact with a copper plate, when the chlorine of the silver chloride combines with the copper, thus etching the metal by the formation of soluble copper chloride. In the Ives process, a plaster of Paris reproduction of a Woodbury relief is inked with a kind of indiarubber file having V-shaped grooves, which leaves large dots by compression on the eminences of the relief, and smaller dots, or none at all, in the hollows. The image so produced is transferred to a zinc block and etched

CONCLUDING REMARKS.

An endeavour has been made to give detailed instructions for those processes now commercially worked, rather than to spend much time in explaining methods obsolete or superseded. At present it may be said that the process to which more attention might well be devoted by British workers is that of collotype, which, in spite of the beautiful results obtainable, is comparatively little practised. It is true that this is largely due to climatic conditions, but with proper precautions and care this hardly seems a vital objection. Of half-tone three-colour work there is now an enormous output; the theory of this is explained in the section on "Photography in Colours," the actual printing being simply a matter of suitable choice of inks and careful registration.

RADIOGRAPHY

INTRODUCTION.

IN the month of January, 1896, the daily newspapers and other periodicals had much to say concerning what was then called "The New Photography." Professor Röntgen had produced pictures on a photographic plate without any help from either camera or lens. It seems that while he was experimenting with an exhausted vessel of glass, known as a Crookes' tube, and passing the current from an induction coil through it, he found that some invisible radiations from the tube blackened and spoilt a packet of sensitive photographic plates, which had been quite protected from the access of light. Possibly the discovery would not at once have aroused the popular interest which it did, had not the professor hit upon the device of placing his hand above the protected photographic plate, with the result that the picture, a shadowgraph, thus obtained showed the bones much more strongly defined than the flesh. In other words, the bones were more opaque to the radiations than the flesh, which was almost transparent to them. It was this weird idea of obtaining a picture of the skeleton of the living hand which at once arrested popular attention. The appearance of a plate thus exposed to the X-rays and developed is shown on Plate 45, while a print taken from it, that is, a positive image, is reproduced on the same plate.

PREVIOUS EXPERIMENTS

Röntgen's discovery was, however, not so novel as most persons imagined, for, some two or three years previous to his experiments, Hertz had noticed that there

were certain radiations from a Crookes' tube, which are known as the Cathode rays, to which various bodies were transparent. And Lenard had pointed out that by employing a tube with a metallic (aluminium) window, certain rays were emitted from the tube, when excited by the current from an induction coil, which would give impressions upon a photographic plate or other sensitive surface. Lenard produced such pictures with the tube, and showed that the action on the photographic plate was not impeded by the interposition of cardboard and other material. Had he used his hand as a screen from the rays, he would have anticipated Röntgen by about two years.

THE FLUORESCENT SCREEN.

Photography, it will have been noted, has little connection with the Röntgen or X-rays, as they are commonly called, save as a means of recording the effects produced. But these effects can also be made visible by means of a specially prepared screen. Such a screen generally consists of a cardboard base, to which an adhesive, such as gum, is applied, after which some chemical body having the property of becoming luminous (fluorescent) under the influence of the X-rays is sifted over the sticky surface. The best screens are prepared with barium platino-cyanide, but as this is an expensive compound, other substances have been sought for and employed. Calcium tungstate gives good results, especially if mixed with a small quantity of powdered mica. Uranium fluoride has also been used for these screens, but it is not so good as the two compounds already named, and has other disadvantages.

THE FLUORESCENT SCREEN IN USE.

The cardboard screen, prepared as stated, is generally held in a wooden frame with a handle, or it may form the bottom of a pyramidal box, with an opening at the apex through which the observer looks at it, the sides of the box serving as a convenient means of shutting off extraneous light. A fluorescent screen is of great use in surgical cases, such as bullet wounds, fractures, etc., where the delay necessary in obtaining a photograph would be prejudicial to the patient. On the field of battle, for example, the surgeon would be able by the use of such a screen to detect the location of a bullet, or note any injury to the bony structure caused by it, provided that a Crookes' tube were at hand and the necessary apparatus for exciting it. The injured limb would be placed between the Crookes' tube and the screen, when a shadow of the parts involved would be plainly observable on the latter. As a matter of convenience the pyramidal box already mentioned may be of leather or cloth, and of bellows form, like a camera body, so that it will shut up into a small space when not in use.

SCREENS FOR PHOTOGRAPHY.

Under certain conditions, the fluorescent screen is useful in intensifying the action of the X-rays on a photographic plate, the screen being placed in contact with the sensitive surface; but for obtaining very fine results this method has the defect of causing granularity in the image, the fluorescent material being usually in a crystalline form. Experiments have shown that there is a distinct advantage in using either a calcium tungstate screen, or one prepared with barium platino-cyanide, but that the uranium screen acts as a retarding agent and should never be employed. It has also been ascertained that there is a great gain in density in using an orthochromatic plate, and that even without the screen a plate bathed in erythrosine and dried has a great advantage over one not so treated. In all these experiments it will be understood that the

plate, or the plate and screen if a screen be used, is wrapped up in black paper to exclude ordinary light.

PAPER ENVELOPES.

By far the most convenient method of handling plates, films, or paper—and either one or the other of these can be used for X-ray work—is to use thick envelopes for their reception; say, for each plate or film, one yellow or red envelope, and one—slightly larger—made of thick black paper. In order to avoid confusion, which in the case of a plate might lead to failure, the film side of the plate should be kept downwards, as it is put in the yellow envelope—the latter having its flap upwards. This first envelope is then inserted in the black one flap foremost—the larger envelope also having its flap upwards. By observing this rule the operator is always sure that the flap of the outer envelope marks the back of the plate, and that it is the other side which must be presented towards the X-ray tube. When it is necessary to identify different negatives they can easily be numbered by arranging at the corner, just before exposure, a few half-inch nails, placing them so as to form Roman numerals. These will appear like lines of clear glass on the negative.

THE SOURCE OF ELECTRICITY.

For the induction coil a source of electricity is requisite, and the choice of that source requires some consideration. A primary battery may be employed, an accumulator may be used, or the current may be obtained from a dynamo, or direct from the street supply. Perhaps, on the whole, the accumulator is to be preferred, for it avoids all the mess and trouble usually associated with every form of primary battery, and it is so portable that there is no difficulty in shifting the apparatus from place to place. The number of cells will, of course, depend upon the size of coil employed. It may be mentioned here that many amateur workers have succeeded in making highly efficient induction coils of

large size. The work does not entail any special tools, but it requires the greatest care and thoroughness. There are several books in which reliable instructions are given for the manufacture of coils. A coil giving a six-inch spark, which is a very useful size for X-ray work, will cost about twenty pounds, but can be made for less than half that sum.

THE WIMSHURST MACHINE.

Some workers prefer as a source of electricity the induction machine known after its inventor as the Wimshurst. By

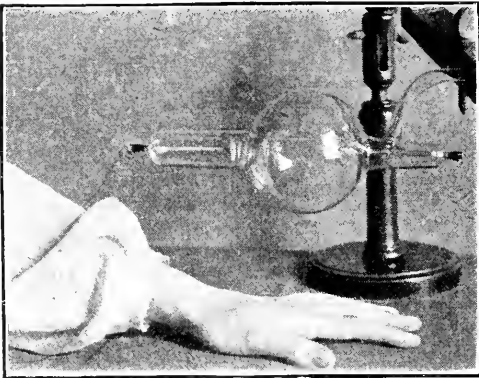

Fig. 918.—FOCUS TUBE.

means of this apparatus both battery and coil are dispensed with, for it produces its own current, and a current which needs no transformation to suit it to the X-ray tube. This machine is well within the power of the amateur worker to construct, and he can do so at a tithe of the cost of an induction coil. The Holtz machine is also well spoken of by those who have employed it for X-ray work. The reason why these convenient static machines were not employed in the early days of Röntgen's discovery is owing to the circumstance that there were then no tubes which were adapted to them.

GEISSLER TUBES.

Most persons have had an opportunity of seeing experiments made with Geissler tubes, which, when connected with the

secondary circuit of an induction coil, give beautiful luminous effects. A Geissler tube is constructed very much after the pattern of an ordinary incandescent electric glow lamp, in that it has two platinum wires sealed within the glass. It is generally made in some fancy design, and uranium glass, which has the property of fluorescing under the influence of the current, is largely used in the better kinds of tubes. Such a tube is exhausted of air to a certain extent, or very often will contain a residual amount of some other gas than air. Tubes exhausted to a far higher extent were subsequently experimented with by De la Rue and Spottiswoode, and eventually were used by Crookes in his classical experiments in "Radiant Matter" exhausted to one-millionth of an atmosphere.

CROOKES' TUBES.

It would take up far too much space, if, indeed, it were necessary, to describe the various forms of tubes which have been made by Sir William Crookes and by others. The first were of uniform section, and gave very inferior shadow pictures. But, soon after Röntgen's researches, Mr. Jackson, of King's College, London, devised the Focus tube, and from that time a most wonderful improvement was manifest in the pictures produced. Instead of woolly outlines the individual bones stood out sharply and well-defined, the very texture of the bone being perfectly visible in the radiographs taken by expert workers. A common form of focus tube is shown in Fig. 918, supported by a wooden stand, with joints and screws so that it can be held in any position. The jaws of this stand are lined with wash leather to protect the glass when the tube is gripped and screwed up tight, and the foot of the stand is weighted with lead so that it shall not easily be overturned.

THE COMPLETE APPARATUS.

The apparatus for the production of the X-rays, not including the source of electricity, is shown by Fig. 919. On the

right hand side is the induction coil, and on the left the glass tube held in its wooden clip. The connecting wires are supported upon glass posts, so that the current shall not stray from its appointed path. These are the essential things for X-ray work, but the coil can be replaced by a static machine as already explained. In addition to these articles, a fluorescent screen will be required for direct observation, and photographic plates or films for records of the effects produced. It is, perhaps, hardly necessary to caution anyone accustomed to deal with electrical apparatus that great care must be exercised in using an induction coil, even of moderate capacity, for it can give a terrible shock. By using the posts made of glass, the connecting wires can be kept away from one another, and from other parts of the apparatus, otherwise they are likely to spark across and give trouble. The discharge must take place through the vacuum tube, and not outside it. Another caution is necessary in dealing with X-ray apparatus. Continued exposure to the action of the rays leads to a destructive action on the skin and nails. Cases are known in which the nails have actually been lost through this action, and soreness due to protracted exposure in surgical cases has more than once resulted in a claim for damages in the law courts. An excessive exposure, adopted for experimental purposes, has even led to serious injury and death. It is a peculiarity of these evil effects that they do not become apparent till some time afterwards.

FLUORESCENCE OF THE X-RAY TUBE.

The beautiful green light which fills the X-ray tube when the electric current is traversing it is due to the fluorescence set up in the glass by the bombardment of the particles which remain within the vessel. The condition of the tube may be safely gauged by the evenness with which this green glow seems to fill the tube, and it is generally found that if this is at its best, the most satisfactory photographic effects may be expected. Dr. Hall Edwards, an experienced worker with

the X-rays, says that he can always tell how the tubes are working by noting the visible amount of fluorescence. Another well-known experimenter, Mr. Isenthal, however, seems to be of the contrary opinion, having stated that the fluorescence of the tube cannot be taken as a criterion of the amount of exposure to be given when using the tube with a photographic plate. He asserts that he has used tubes which fluoresce excellently, and with which he can discern upon a screen many of the deeply seated structures of the body, and that those same tubes totally fail to afford satisfactory photographs.

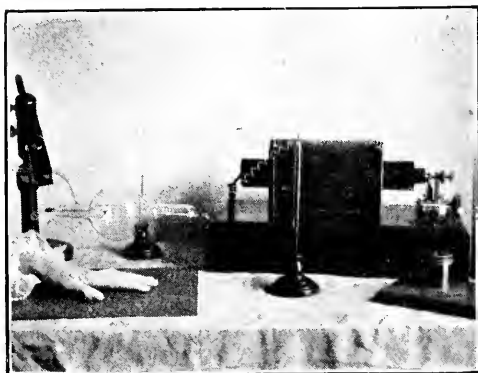

Fig. 919.—APPARATUS FOR PRODUCTION OF X-RAYS.

EXHAUSTION OF THE TUBE.

The X-ray tube is exhausted of its contained air by the "Sprenzel," or some similar form of mercury pump, and the exhaustion is generally carried to about one-millionth of an atmosphere. This is a high vacuum, but very far from the theoretical perfect vacuum. Sir William Crookes has pointed out that it is only a high vacuum by courtesy, and he shows that, although it may seem that when the air is reduced to one-millionth part of its bulk the residue must be trifling, this idea is fallacious. A bulb of glass five inches in diameter contains more than a quadrillion molecules, and when it is exhausted to one millionth of an atmosphere it will still contain more than a trillion.

So that an X-ray tube with a five-inch bulb, having what we call a high vacuum, contains more than 1,000,000,000,000,000,000 molecules of air.

USING CURRENT FROM THE STREET MAIN.

The electric current from the street main may be used as a source of supply for the induction coil. In the case of a 100-volt supply a resistance of 12 ohms is wanted, which can be reduced to 6 or 4 ohms as may be required. This can be brought about by the use of a platinoid resistance coil, and is the system adopted by Mr. Apps, the well-known coil maker. Other workers prefer to use as resistance, on a 100-volt current, eight 50 c.p. lamps in parallel. It is obvious that if such lamps are employed they must be carefully boxed up while any photographic experiments are in progress, but of course the gelatine plate is safe enough when it is jacketed in black paper or opaque envelopes. Mr. Campbell Swinton, who was one of the first to experiment in this country with the X-rays, happened to have in hand some apparatus for high-frequency phenomena, and he explained at a lecture how he successfully adapted this apparatus to X-ray work. He used an alternating current from the street supply to excite an induction coil which charged a battery of twelve Leyden jars. The discharge from this battery was taken to a high-frequency (Tesla) coil, in oil, and to the secondary coil of this was connected the Crookes' tube.

THE CROOKES' TUBE IN USE.

A Crookes' tube is working at its best when all the space in front of the sloping screen connected with its anode is filled with an apple-green light. If by any mistake the current should have been allowed to traverse the tube in the wrong direction, this beautiful effect is not seen, but, instead, there are intermittent flashes of violet light, and a peculiar crackling noise is heard. In using a coil, such a mistake is at once remedied by turning the commutator handle to the other side. The apparatus must be so arranged that

the sloping screen is turned towards the plate, so as to embrace the entire object placed upon it. In the case of a hand being X-rayed the operator should be careful to observe that the tube is not placed too far forward or backward, in which case part of the picture would be cut off and the corresponding part of the plate would be left blank.

SUITABLE PLATES FOR RADIOGRAPHY

This is a very difficult matter to determine, for it by no means follows that because a plate is deservedly recommended for its great sensitiveness to light, and its general excellence for ordinary photographic purposes, that it will do equally well for X-ray work. A very quick plate of one brand may be equalled by a much slower plate of another make. And while some sensitive papers give good results, others are almost inert. The question of the choice of developer also comes under consideration. The old ferrous-oxalate developer, which some years ago was such a favourite and was used so much in continental studios, will generally give good results for X-ray work. Another developer which may be recommended is hydroquinone (Payne's formula). Pyro is not so satisfactory for X-ray work. Anyone taking up this branch of photography would do well to experiment with different brands of plates, not larger than quarter-plate size, and with different developers, before running to the expense of using the large plates necessary for taking an entire hand. The 10 × 8 size is a convenient one for obtaining radiographs of hands or feet. The above remarks apply equally to celluloid films.

RADIOGRAPHS ON PAPER.

Very good results can be obtained on a description of bromide paper specially prepared for X-ray work, and as paper is quite transparent to the radiations, it is possible to obtain a number of impressions with one exposure by placing a pile of the papers beneath the object radiographed. A visionary inventor, some

time ago, suggested that newspapers could be economically produced by this means. This is one of the many fallacies to which the discovery of the X-rays has given birth. Another one is that letters might be surreptitiously copied in the same manner without removing them from their envelopes, but the originator of this idea was ignorant of the important fact that writing ink is as transparent to the rays as paper.

RADIOGRAPHS OF COINS, ETC.

Dr. Hall Edwards, in a lecture before the Royal Society, described several experiments which he had made in the examination of metals by the X-rays. Not only can the differences of thickness of various metals be shown by differences of density after development, but it is actually possible to get a mixed image from the two sides of a coin, and even from an impression made in thin metallic foil. Thus the lettering and trade mark on a leaden capsule of a pyro bottle were distinctly reproduced. At first, it was thought these markings were due to differences of thickness of the metal caused by pressure in making the stamp, but Dr. Edwards disproved this theory by taking the impression of a medal on thin foil with no more pressure than that exerted by the ball of his thumb. In this way he was able to get an image of any medal which he desired to copy. He believes that the production of the image in this way is due to the varying distances of the surface of the pressed metal from the gelatine plate, but he admits that the phenomenon may be due to some entirely different cause which is at present obscure.

RADIO-ACTIVE SUBSTANCES.

The discovery of the X-rays induced more than one earnest worker to experiment with different substances in order to ascertain whether any of them would emit radiations of a similar character. The foremost of these was M. Becquerel, who found that the salts of uranium gave out radiations which would affect a photo-

graphic plate wrapped up in black paper, *i.e.* paper impervious to light. He also showed that such radiations would penetrate wood and aluminium. In compliment to him they were called "Becquerel rays." The principal ore of uranium is pitchblende, and this mineral, if placed above a covered photographic plate, soon gives evidence of radio-activity. In Fig. 920 is shown a lump of pitchblende from Saxony. It is also found in Bohemia, in the United States, and in Cornwall.

RADIUM.

Professor and Madame Curie investigated the residue from pitchblende after



Fig. 920.—SAMPLE OF PITCHBLENDE.

the uranium had been extracted from it, and found that it was more radio-active than uranium itself. Eventually a body was isolated from the residue which was 300 times more active than uranium. This was named potonium. Another new substance was isolated, which the Curies named actinium, and finally radium was discovered, possessing one million times the activity of Becquerel's salts. Radium, from its extreme rarity, as well as its properties of emitting heat and light without any perceptible diminution in its bulk, has aroused great interest, and has been the subject of so many articles in newspapers and other publications that it is not necessary here to devote much space to its peculiar properties. It is

separated from the residue of pitchblende by a series of complicated chemical operations, one ton of material yielding only a few grains of radium in the form of the



Fig. 921.—GLASS TUBE CONTAINING RADIUM.

bromide or chloride of the metal. Radium has the highest atomic weight of all the elements, namely, 225. A glass tube containing radium is shown by Fig. 921.

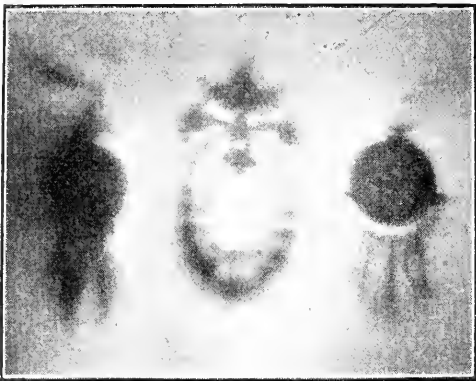

Fig. 922.—PRINT FROM NEGATIVE OBTAINED BY ACTION OF RADIUM.

PHOTOGRAPHIC ACTION OF RADIUM.

Like the X-rays, radium will darken a photographic plate protected by black paper, but whereas the X-rays will leave their mark by a few seconds' exposure, the radium compounds require hours. Fig. 922 is a print from a plate which,

wrapped in black paper, placed in a box, and covered with three earrings, was exposed to a tube of radium chloride for twenty-four hours. Fig. 923 shows the impression produced upon a similar plate placed at the same time outside the box, above the perforated silver lid of a soap box belonging to a dressing case. Neither the X-rays nor radium radiations are stopped by the interposition of a photographic film, so that no image can be printed on a plate from an ordinary negative. But if a negative with a plate or paper beneath it

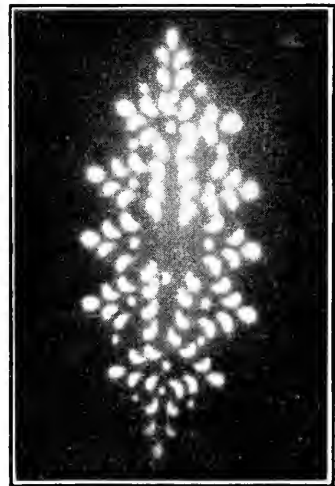

Fig. 923.—DESIGN ON PLATE OBTAINED BY ACTION OF RADIUM.

be exposed for some hours to the light which is continually given out by radium, a picture is produced. Such a picture printed by the light from radium is shown, as a curiosity, in Fig. 924. In this case the radium tube was fastened inside the lid of a plate box, the negative and sensitive paper lying beneath it in the box. The vignettted effect is secured by the centralisation of the light in the tube above the negative.

THE SPINTHARISCOPE.

The Spinthariscopes is an ingenious little instrument devised by Sir William Crookes for showing the action of a

minute quantity of a salt of radium upon a fluorescent screen. It consists of a lens set in a tube, which has the same outward appearance as an ordinary focussing eyepiece, only that the tube is closed at its lower end with a screen coated with zinc blende (zinc sulphide). Just above this screen is a pointer, which can be moved from the outside so as to traverse different portions of the surface, and has been touched at its extremity with a solution of radium salt and allowed to dry. But this minute and invisible trace of the compound is quite sufficient to excite the phenomenon of fluorescence on the prepared screen, and, upon looking through the lens in a dark room, a miniature bombardment is seen to be going on there. Tiny points of light appear, as the electrified particles of matter strike the screen, and the appearance is like that of a continual discharge of tiny sparks. The Spintariscopes principle has also been applied to a slide which can be viewed on the stage of an ordinary microscope.



Fig. 924.—PHOTOGRAPH PRINTED BY DIRECT LIGHT OF RADIUM.

CONCLUDING HINTS.

It may be useful to give definite instructions for making a fluorescent screen. Pure barium platino-cyanide is reduced to a fine powder and mixed with megilp, as used for oil painting. The mixture is applied with a brush to a sheet of glass of the desired size, securing an even coating about $\frac{1}{10}$ in. thick. Without waiting for the mixture to dry a sheet of very thin ebonite is laid over it, or, if this cannot be obtained, black paper, pressing lightly into contact. In use, the ebonite or black paper side is placed nearest to the tube, the glass side being towards the

observer. Another method is to stretch a sheet of stout parchment on a frame, and, after coating it with thick celluloid varnish, to dust the powdered platino-cyanide over the sticky surface and allow to dry. When perfectly dry, the resulting screen may be given a coating of thin celluloid varnish, which must be applied gently and with care, so as not to damage the surface. The varnish may be made by dissolving cuttings of old celluloid films—from which the gelatine has been removed—in acetone, till a viscid liquid is obtained. The thicker mixture may be thinned by adding more acetone.

MISCELLANEOUS ITEMS.

MAKING SQUARE BELLOWS.

THE following information is given for the instruction of those who wish to make bellows. In making square bellows first cut out a pattern in paper, so that when the more expensive material is being used, it may be worked up with confidence and without damaging it. Procure sufficient

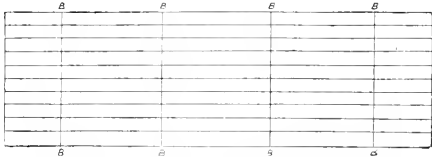

Fig. 925.—PATTERN FOR SQUARE BELLOWS.

black lining and leather (morocco is best) for the size of the bellows contemplated, and cut out a rectangular piece of lining that, when folded, will be of the right dimensions. The leather, which has been previously rendered limp by dampng, is attached to this with strong bookbinders' paste. Wherever it is necessary for the leather to overlap, it should be shaved



Fig. 926.—CAMERA BELLOWS: FIRST FOLD.

sufficiently thin with a sharp knife to make the double thickness equal to the single. Mark the position of the folds with a chalk pencil, as in Fig. 925. Before the leather gets quite dry, proceed to fold it fan-fashion, each fold to be 1 in. in depth, as in Fig. 926. Then place under pressure. When the material is nearly dry, fold it the contrary way, four sharp creases, as shown by the lines B B B B, to form the corners of the bellows. Now open it out and securely paste together the two ends of the

strip in the centre of one side in preference to making the joint at one corner. There will now be formed a tube, as Fig. 927, consisting of leather outside and lining inside. This is pressed into shape with the fingers and thumb. The corners will be the only part likely to give much trouble, and must be pinched up, as in Fig. 928. All the corners being finished in this manner, press together and let them remain till absolutely dry to make the folds retain their form. When dry, work the bellows backwards and forwards until pliable and ready for attachment to the camera frame. It must be borne in mind that the space inside must be equal to the size of the plate to be used; thus, if the folds are 1 in. in

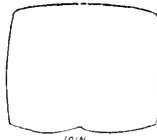

Fig. 927.



Fig. 928.

Fig. 927.—SECTION THROUGH BELLOWS.

Fig. 928.—FOLDED BELLOWS.

depth, an outside measurement of an inch larger each way will be necessary, so that the fold will not cut off the light from the plate when in use, and only slightly extended. Half an inch or so must be left for joining up.

MAKING BELLOWS WITH CARDBOARD STRIPS.

Another very convenient way of making square bellows is to employ strips of cardboard, which are covered with bookbinders' cloth or black twill. Cut a number of strips of cardboard 1 in. wide and 7 in. long, also a similar number $5\frac{1}{4}$ in. long,

and slope off all the ends as shown by Fig. 929. On a flat table lay a piece of cloth of sufficient size for the bellows, coat it with strong paste, and lay on the strips of card, nearly touching each other: 14 of the longest, then 14 shorter, then 14 long, and again 14 shorter, as in Fig. 929; let them dry, then paste another layer of bookbinders' cloth over them, the card strips being sandwiched between. When nearly dry, fold them up after the manner of a fan and put

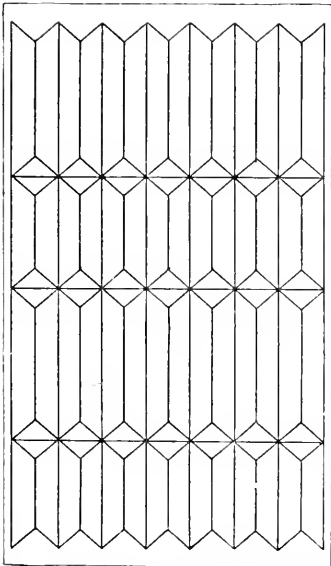

Fig. 929.—CARDBOARD STRIPS FOR SQUARE BELLOW.

under pressure till quite dry; then, first of all, crease them sharply and longitudinally in each part where the ends of the shorter cards meet the longer; bend the whole into a tube, and glue the edges together. When the glue is thoroughly dry, pinch up the corners, and the bellows are complete, ready to be glued into the back and front frames, to which they are secured by screwing on additional strips of wood.

MAKING CONICAL BELLOW.

For making conical bellows, use, as before, leather and black twill joined with a cement of 4 parts of thin glue and 1 part of flour paste, the latter rendering the glue less likely to crack. Two thicknesses of

twill should be used. About $1\frac{1}{2}$ yds. by $\frac{3}{4}$ yd. each of leather and twill will be required. Pin the material face down on a table, and draw a line A A (Fig. 930) in the centre of one edge. From the centre of this line erect a perpendicular B B 20 in. long. At the top draw a line C C at right angles on both sides 5 in. long, and then draw lines joining the points C A and C A. The angles for other sides are found as follows: With a blunt compass, taking care not to pierce the material, describe a circle with centre A and any radius. Where the circle intersects C A as centre, and where

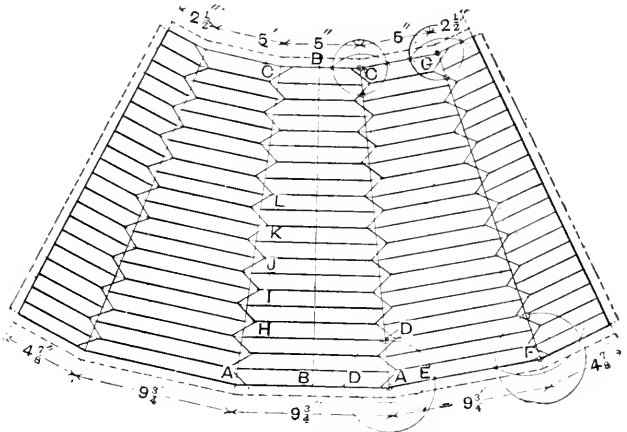

Fig. 930.—PATTERN FOR CONICAL BELLOW.

it intersects A B as radius, strike the arc D E, and draw a line $9\frac{3}{4}$ in. long through A E to F. At the top proceed in the same way (from C to G is 5 in.), and join the points G F. The other sides are ruled in the same way, except that the joined side is divided into two parts as shown. The material overlaps $\frac{1}{2}$ in. all round to allow for joining. Lines should then be ruled parallel to each base line at 1 in. apart (see diagram). This may be done with a T-square by pinning the material loosely at upper B. Whilst in this position, the fold lines are ruled with a set-square. If the T-square be placed parallel with a line with the set-square on it, the inside edge will give an angle of 45° —the direction of required line. The lines H I J K, etc., will each be rather less than $\frac{1}{4}$ in. shorter to

allow of taper. In this case there would be about twenty-one folds. When the strips of card and black twill have been attached in place, and the outside edges of twill trimmed to shape of leather, the bellows may be joined up to form a cone and the sides bent into shape with the fingers, the narrower spaces going in. A trial on a piece of paper is recommended. The lines bending inwards require ruling with a hard point. It is advisable first to practise the ruling and creasing on some brown paper.

BLACKENING INSIDE OF BELLOWES.

For blackening the interiors of bellows, use methylated spirit in which some resin or shellac has been dissolved, and then lampblack added. The liquid, if shaken before use, should dry a dead black, which should not be removed on rubbing; more shellac or resin must be used if the black rubs off. It is applied with a brush.

DEAD BLACK FOR CAMERA WOODWORK.

A good dead black for the interior woodwork of a camera is made by dissolving 1 oz. of shellac and $\frac{1}{2}$ oz. of borax in 20 oz. of hot water; when the shellac is quite dissolved add about 1 drachm of glycerine and sufficient aniline black (soluble in water) to form a good solid black. This is applied with a fine camel-hair brush, and a couple of coats are sufficient to produce a rich velvety dead black that neither rubs off nor produces particles of black dust, so troublesome in some cameras and dark slides. Another recipe is: Aniline black, 100 gr.; gum shellac, 200 gr.; methylated spirit, 5 oz. Dissolve thoroughly, and apply with a soft brush quickly. Negative varnish mixed with powdered lampblack may also be used. An excellent blacking for wood or leather may be made by mixing lampblack and French polish. The quantity of the latter must be only sufficient to make it adhere properly when dry. It is best applied with a flat camel-hair brush. Too much polish will result in a shiny surface. The best way is to mix it in a saucer to the desired consistency (thinning with methylated spirit if necessary), and try from time to time upon a piece

of wood until exactly right. The best results are obtained with home-made blacking freshly mixed.

BLACK FOR BRASSWORK.

To blacken camera brasswork, first clean with fine emery or sand, wash, and immerse in a saturated solution of nitrate of copper. After about two minutes, take out and heat over a Bunsen burner or ordinary spirit flame. Repeat this several times. Copper nitrate may be made by dissolving 1 oz. of copper filings in 2 oz. of nitric acid. The filings should be added to the acid in the open air, and stirred with a glass rod till as much as possible is dissolved. If the whole of the article is to be blackened, suspend with a hook of copper wire. When blackened, rub over with a greasy rag. To blacken zinc-work in a camera, clean and wash as before, then prepare a solution of chloride of copper 45 gr., nitrate of zinc 30 gr., and water 4 oz., to which is added $\frac{1}{2}$ oz. of hydrochloric acid. Immerse the zinc in this, wash and dry. Tin fittings are blackened with carbon black mixed with sufficient French polish to make it adhere properly; more polish makes the black glossy. Another good formula is 1 oz. of water, 15 gr. of borax, 30 gr. of shellac, 15 minims of glycerine, and 60 gr. of nigrosin. Boil till dissolved, then add the nigrosin.

MAKING SINGLE FLAP SHUTTER.

The single flap shutter (Fig. 931) is a very simple type, consisting of a flap, A, which is raised by a rubber band, and is closed by means of a weighted arm, B, attached to it. For convenience of description, it is assumed that the shutter is to be made for a lens whose greatest working aperture is 1 in. The dimensions can be calculated easily for a smaller aperture. The back of the shutter is a rectangular piece of wood about $\frac{1}{8}$ in. thick, and not less than $1\frac{1}{2}$ in. broad, the breadth being about $\frac{1}{4}$ in. more than the diameter of the hood, or mount, of the lens the shutter is to fit; the length will have to be determined later. On the back of this wood, and equidistant from three

of its edges, mark out a circle having a diameter equal to that of the lens mount; bore a small hole through the centre of the circle, and with this hole as centre, on the other side of the wood mark a square of $1\frac{1}{4}$ in. side. Cut away the wood enclosed by this square to a uniform depth of about $\frac{1}{16}$ in., and then bore a hole of suitable diameter by means of a centre-bit right through the wood, its centre being the small hole already bored. Reference to Figs. 932 and 933 will make this clear.

full lines shown in Fig. 935, and bend back the pieces *a a* behind *b*, and hammer flat. Now bend *b* at right angles to *c*, and solder to front of flap as shown in Fig. 931. It is well to run a little solder behind *b* to prevent it being bent back; also file off any sharp corners. The flap is now complete, and two grooves should be cut across the wooden back, so that when the flap is placed in the recess the wire does not prevent it from fitting closely over the hole. It is well to glue a piece of thin cloth round the lower part

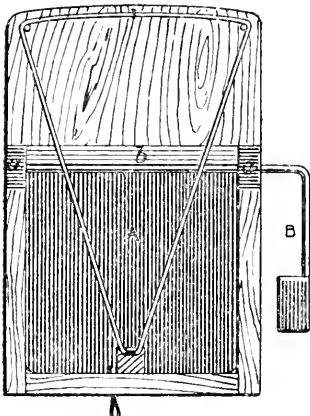

Fig. 931.



Fig. 932.

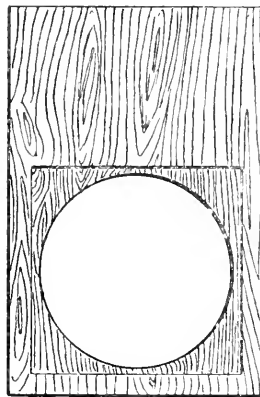

Fig. 933.

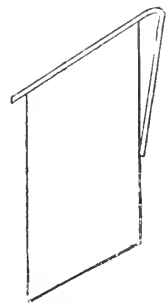

Fig. 934.



Fig. 935.

Fig. 931.—SINGLE FLAP SHUTTER. Fig. 932.—SECTION OF SINGLE FLAP SHUTTER. Fig. 933.—BACK OF SHUTTER. Fig. 934.—SHUTTER FLAP. Fig. 935.—CATCH FOR FLAP.

THE METAL FLAP.

For the shutter flap, cut out a square piece of tin-plate or brass to fit easily the square recess in the wood. Thoroughly clean the metal flap, and dead-black it (see p. 714). Solder a piece of stout brass or tinned iron wire 3 in. long across one edge of the unblacked side of the flap, leaving about 1 in. projecting over one side (see Fig. 934); bend the projecting end at right angles at about $\frac{1}{2}$ in. from the flap, slightly inclining it to the front of the flap, and solder a small lead weight to the end of the bent wire. A projecting piece must be attached near the lower edge of the flap for an elastic band to be stretched over. To do this, cut a piece of thin tinfoil $\frac{3}{8}$ in. by $\frac{1}{4}$ in. along the

of the hole, and so prevent the tendency to rebound when the flap falls. Small wooden caps, *a a* (Fig. 931), are glued on so as to keep the wire in position, and a thin strip, *b* (Fig. 931), across above the wire, so that the flap cannot open to more than 135° ; otherwise, it will not close again without aid.

USING THE SHUTTER.

Two small tacks or pins are now driven into the back at the top corner, and a pin into the centre at the top, as shown in Fig. 931; this pin is then bent to form a hook. In using the shutter, an india-rubber band is placed over the hook and stretched over the projection on the flap; when released, the band gives an upward

movement to the flap. To give a shorter exposure, the band is stretched across over the two tacks and the projection. Care must be taken to place the pins so that the rubber band will detach itself from the flap when full open, thus allowing it to close again by the downward pull of the weighted arm. A catch to keep the flap closed must be added; all that is necessary for this is a pin pushed through the bottom of the wood so as to pass in front of the flap when closed, and capable of moving up and down easily. The head should be upwards, and a small hollow should be made for the head when the pin is pulled down, or the flap will not open. The bottom end may be bent into a loop, and a cord attached.

FITTING SHUTTER ON LENS.

The single flap shutter, though inferior to the drop and flap shutter, works well for moderately slow exposures (half a second to one-tenth of a second), but is not suitable for more rapid exposures. It has the valuable advantage of giving a larger exposure to foreground than sky, the higher and better lighted parts of the subject getting less exposure than lower and generally less illuminated parts. For the purpose of fitting on to the lens mount a short piece of cardboard or paper tube (made by pasting a number of turns of paper together round a roller), or a wooden ring which just fits the mount, is glued to the back of the shutter, *c c* (Fig. 932), so as to be concentric with the hole. Care should be taken that this collar is in contact with the back all round, so that light cannot get through to the lens between collar and back of shutter.

COMIC PHOTOGRAPHS.

Caricature photographs may be made by drawing a comic figure or the body of some animal or bird on a sheet of stout cardboard. This is then held just below the sitter's head, so that it apparently joins on to the painted body. The background should, if possible, be the same colour as the card, and the junction between the latter and the sitter's neck may

be retouched out on the negative. Sometimes a better join is obtainable by cutting out a semicircular piece at the top of the card to rest the neck in. Such cards are obtainable in many designs.

"DOUBLES" AND "TREBLES."

These ingenious arrangements, in which the same person is seen talking to, drinking, or playing cards with himself, are managed as follows: A square wooden tube is made with an opening the same size as the glass of the focussing screen, and as long as the focal length of the lens to be used. This is blacked inside, and at one end is provided a rebate with turn-buttons. The furniture of the room having been suitably arranged for all the positions, the model is placed in the first position, and, using the ground glass as a guide, a piece of thin tin or zinc, or even stout cardboard, is cut to such a shape as will mask out the remaining portion of the plate. A similar piece is cut for each of the positions. The square tube is now placed against the camera front, with the rebate outside, and the first piece of shaped metal or cardboard is fastened in position by means of the turn-buttons, the first exposure being then given. The model is then shifted and made to assume the second position, the masking on the front of the tube suitably changed, and the next exposure given, and so on. Care should be taken that the exposures are equal. Another method is to take separate negatives of each position, cut the figures out of the resulting prints, paring the edges with a sharp knife to prevent the overlapping being manifest, and to stick them on a suitable print of the pre-arranged background. A copy negative is then made from the composite print. The latter method obviously allows the figures to come in front of, or overlap, each other if necessary, which cannot be done in the previous way.

COMPOSITE PHOTOGRAPHS.

The method of cutting out figures, etc., from different prints, sticking them upon the same base and copying them, is also

that adopted for what are known as composite photographs. Sometimes quite a large number of figures are introduced into a group in this manner, the background being worked up to any desired extent with water colour and white paint, and joining marks or similar defects concealed by retouching and spotting. Albumenised paper is the most suitable for this kind of work. In copying old and faded photographs this plan is often made use of, the figure being cut out from the copy print and pasted on a suitable background, or on a plain card, on which the background is then painted. Greys and neutral tints are the best colours for the purpose. No attempt need be made to match the colour of the print, except in spotting the latter. Slow plates should be employed for copying the combined print, and an ample exposure given.

MAGIC PHOTOGRAPHS.

An ordinary albumen print is made, fixed without toning, and well washed. It is then immersed in a strong solution of mercuric chloride until the picture is completely bleached away, after which it is washed and dried. Some sheets of blotting paper are prepared by soaking in a saturated hypo. solution and hanging up to dry. When it is desired to make the invisible picture appear, two sheets of the prepared blotting paper are moistened slightly, and the print is laid between them for a second, when the original picture will immediately reappear in all its former strength. Another, and perhaps more striking method, is to place the bleached print in a clear hypo. solution, which, to the uninitiated, will appear like water, or to brush it over with a sponge dipped in hypo.

DISTORTED PHOTOGRAPHS.

Very curious and amusing effects may be produced by the use of curved mirrors, of convex or concave form, such as are frequently seen at the entrances of cheap restaurants. The sitter is posed in front

of this, and the image in the mirror photographed. Great care is necessary to avoid the reflections of extraneous objects, or of any bright light which might suffice to fog the plate. Another means of distortion is to throw the swing-back of the camera out of the vertical, when either a diminished head and enormous hands or boots may be obtained, or the reverse. It will be necessary to stop down the lens if the latter method is adopted, or part of the picture will be out of focus.

LUMINOUS PHOTOGRAPHS.

Obtain a positive transparency on glass, varnish the film side, and coat it with luminous paint. This is obtainable of most artists' colourmen. When dry, place a piece of thin wood or cardboard at the back, with a ring to hang the picture up by, and bind the two together with strips of gummed paper or American cloth. If exposed to the light during the day, the photograph will be luminous at night or in the dark. Another way is to spread a thin coating of glue over cardboard, and sprinkle the latter with powdered barium or calcium sulphide. A rather light, finished print is rendered transparent with castor oil, the excess being blotted off, and attached to the cardboard with thin glue or strong paste, the whole being dried by heat. Or a silver print may be rendered translucent by any of the methods used in the crystoleum process, after mounting in optical contact on glass, the luminous paint being then applied at the back.

"BOTTLE IMPS."

A photograph showing the sitter confined in a bottle may be made as follows: First obtain a negative of the sitter against a plain background, of not too dark a tint. Naturally, a full-length portrait is to be preferred. A photograph of the bottle is next obtained, to such a scale that the figure may conveniently appear inside it, and by the combined use of the two negatives a print is readily secured giving the required result.

WEIGHTS AND MEASURES.

BRITISH.

APOTHECARIES WEIGHT (*by which Formulæ are made up*).

20 grains	= 1 scruple	= 1.296 grammes.
3 scruples	= 1 drachm = 60 grains	= 3.887 "
8 drachms	= 1 ounce = 480 "	= 31.106 "
12 ounces	= 1 pound = 5760 "	= 373.276 "

AVOIRDUPOIS WEIGHT (*by which Chemicals are sold*).

16 drachms	= 1 ounce = 437½ grains	= 28.4 grammes.
16 ounces	= 1 pound = 7000 "	= 453.59 "

LINEAR MEASURE.

12 inches	= 1 foot = 30.48 centimetres.
3 feet	= 1 yard = 91.44 "

FLUID MEASURE.

60 minims	= 1 drachm	= 3.5	} Cubic centi- metres
8 drachms	= 1 ounce = 480 minims	= 28.4	
12 ounces	= 1 pound = 5760 "	= 310.8	
20 "	= 1 pint	= 568.0	
2 pints	= 1 quart = 40 ounces	= 1.136 litres.	
4 quarts	= 1 gallon = 160 "	= 4.544 "	

(The American pint is 16 ounces.)

METRIC SYSTEM.

WEIGHT.

10 milligrammes	= 1 centigramme = 1543 grains.
10 centigrammes	= 1 decigramme = 1543 "
10 decigrammes	= 1 gramme = 15.432 "
10 grammes	= 1 decagramme = 154.323 "
10 decagrammes	= 1 hectogramme = 3 oz. 227½ "
10 hectogrammes	= 1 kilogramme = 35 oz. 87½ "

LENGTH.

10 millimetres	= 1 centimetre = 3937 inch.
10 centimetres	= 1 decimetre = 3.937 "
10 decimetres	= 1 metre = 39.37 "

FLUID.

1 cubic centimetre (c.c.)	= 17 minims.
10 " centimetres = 1 centilitre	= 170 "
	Fl. oz.
10 " centilitres = 1 decilitre	= 100 c.c. = 3.52
10 " decilitres = 1 litre	= 1000 c.c. = 35.2

RULES FOR CONVERSION OF METRIC INTO BRITISH FORMULÆ AND VICE VERSA.

To Convert

Centimetres into inches:	divide by 2.54 (2½).
Inches into centimetres:	multiply by 2.54 (2½).
Millimetres into inches:	divide by 25.4 (25½).
Inches into millimetres:	multiply by 25.4 (25½).
Metres into yards:	multiply by 1.094 (1¼).
Yards into metres:	divide by 1.094 (1¼).
Cubic centimetres into fluid ounces:	divide by 28.35 (28½).
Fluid ounces into cubic centimetres:	multiply by 28.35 (28½).
Litres into pints:	multiply by 1.76 (1¾).
Pints into litres:	divide by 1.76 (1¾).
Grammes into grains:	multiply by 15.43 (15½).
Grains into grammes:	divide by 15.43 (15½).
Grammes into ounces (avdp.):	divide by 28.35 (28½).
Ounces (avdp.) into grammes:	multiply by 28.35 (28½).
Kilogrammes into pounds (avdp.):	multiply by 2.205 (2¼).
Pounds (avdp.) into kilogrammes:	divide by 2.205 (2¼).

THERMOMETRIC RULES.

To convert Centigrade into Reaumur—

Degrees Centigrade: multiply by 4, divide by 5.

Example: 100° C. multiplied by 4 divided by 5 = 80° R.

To convert Centigrade into Fahrenheit—

Degrees Centigrade: multiply by 9, divide by 5 + 32.

Example: 60° C. multiplied by 9 divided by 5 = 108 + 32 = 140° F.

To convert Reaumur into Centigrade—

Degrees Reaumur: multiply by 5, divide by 4

Example: 30° R. multiplied by 5 divided by 4 = 37.5° C.

To convert Fahrenheit into Centigrade—

Degrees Fahr. — 32: multiply by 5, divide by 9.

Example: 50° F. — 32 = 18, multiplied by 5 divided by 9 = 10° C.

To convert Fahrenheit into Reaumur—

Degrees Fahr. — 32: divide by 9, multiply by 4.

Example: 50° F. — 32 = 27, divided by 9 multiplied by 4 = 12° R.

To convert Reaumur into Fahrenheit—

Degrees Reaumur: multiply by 9, divide by 4 + 32.

Example: 40° R. multiplied by 9 divided by 4 = 90, + 32 = 122° F.

TABLE FOR FINDING THE MINIMUM LENGTH OF STUDIO FOR
A GIVEN LENS.

DISTANCES IN INCHES FROM OBJECT TO LENS.

Equivalent Focus of Lens, In.	Equivalent Focus of Lens,															
	3 in. high.	4 in. high.	5 in. high.	6 in. high.	8 in. high.	10 in. high.	12 in. high.	16 in. high.	20 in. high.	24 in. high.	30 in. high.	36 in. high.	48 in. high.	54 in. high.	60 in. high.	72 in. high.
3	75	57														
4	100	76														
5	125	95	61	52	50											
6	150	114	77	65	60											
8	200	152	125	104	80	65	56									
10	250	190	154	130	100	82	70	55								
12	300	228	184	156	120	98	84	65	55							
16	400	301	246	208	161	131	112	88	72							
20	500	380	308	260	200	164	140	110	90	64						
24	600	456	366	312	240	196	168	132	110	96	68					
30	750	540	462	390	300	246	210	165	136	120	81	72				
36	900	684	552	463	360	307	252	198	165	144	122	108	90	84	79	72
48	1200	912	732	624	480	393	336	264	220	192	163	144	120	112	105	96
60	1500	1080	864	780	600	492	420	330	272	240	204	180	150	140	132	120
72	1800	1368	1108	936	720	614	504	395	321	288	244	216	180	168	158	144

DISTANCES IN INCHES FROM LENS TO GROUND GLASS.

Equivalent Focus of Lens, In.	Equivalent Focus of Lens,															
	3 in. high.	4 in. high.	5 in. high.	6 in. high.	8 in. high.	10 in. high.	12 in. high.	16 in. high.	20 in. high.	24 in. high.	30 in. high.	36 in. high.	48 in. high.	54 in. high.	60 in. high.	72 in. high.
3	3	3														
4	4	4														
5	5	5	4	4												
6	6	6	6	6	6											
8	8	8	8	8	8	7	9									
10	10	10	10	10	11	11	11	12								
12	12	12	12	13	13	13	14	14	15							
16	16	16	17	17	17	18	18	19	20	21						
20	20	21	21	21	22	22	23	24	25	26	22					
24	25	25	25	26	26	26	28	28	30	32	28	24				
30	31	31	32	32	33	34	35	36	38	40	34	30	33	35		
36	37	38	38	39	39	40	42	44	46	48	41	36	40	42	44	48
48	50	50	51	52	53	54	56	58	61	64	51	45	50	52	55	60
60	62	63	64	65	66	68	70	73	77	80	61	54	60	63	66	72
72	75	76	77	78	79	80	84	88	92	96	72	60	70	72	75	84

Suppose the lens used is 24 in. equivalent focus, and you wish to make a full length portrait of a man 6 ft. high, in which the image will be 6 in. high. Look at the left-hand column for lens focus, and in the top line for size of image. At the intersection of these columns we find 312 in. = 26 ft., to be the distance the person must stand from the lens. In the next table, using the same lens and size of image as before, at the intersection of the columns we find 26 in., which represents the distance of the ground glass from lens centre. And in the same way any lens and size of image may be computed for.

PERMITS TO PHOTOGRAPH.

For permission to photograph the various buildings and public places mentioned below, application must be made to the authorities quoted, enclosing in all cases a stamped addressed envelope for reply—

Cathedrals and Churches.—The Deans and Vicars.

Colleges of Oxford.—The Master or Dean.

Ruins of Abbeys and Castles.—The Stewards.

London Parks and Open Spaces, &c., under the control of the L.C.C.—The London County Council, Spring Gardens, S.W. Permits are granted for twelve months.

The Royal Parks—St. James's, Green Park, Hyde Park, Greenwich Park, Bushey, Richmond and Hamp on Court Parks, Kensington Gardens, Regent's Park and Primrose Hill.—H.M. Board of Works, Whitehall, S.W. Permits granted for twelve months.

Kew Gardens.—The Directors. No photographing is allowed on Sundays, Christmas Day, Good Friday, or Bank Holidays.

Windsor Green Park and Virginia Water.—Captain Campbell, Holly Grove, Windsor Park.

Zoological Gardens, Regent's Park.—Secretary, Zoological Society, 3, Hanover Square, London, W.

Epping Forest, Highgate Woods, St. Paul's Churchyard, Burnham Beeches, Wanstead Park, Coulsdon Common, West Wickham Common, and Queen's Park, Kilburn.—Town Clerk, Guildhall, E.C.

British Museum.—The Chief Librarian. The application must specify the objects to be photographed, and the name of the photographer. Permits are only given to amateurs with respect to exhibited objects.

Botanical Gardens, Regent's Park.—The Secretary.

South Kensington Museum and Bethnal Green Museum.—The Secretary, Science and Art Department, South Kensington, S.W.

Natural History Museum, South Kensington.—The Director.

Tate Gallery.—The Trustees.

National Gallery.—The Director.

Guildhall Gallery.—The Library Committee. Guildhall.—City Lauds Committee.

Westminster Abbey.—The Dean. A form of application must be first obtained from the Chapter Clerk, The Sanctuary, Westminster, S.W., and this must be signed by a member of Parliament, a barrister, or an Anglican clergyman.

House of Lords.—Secretary, Lord Chamberlain's Office, House of Lords. Rarely granted.

Tower of London—exterior only.—The Constable of the Tower.

Buckingham Palace.—Personal application.

Chelsea Hospital.—Personal application.

Lambeth Palace.—Inquire at Gate.

INDEX.

(Illustrated subjects are denoted by asterisks.)

A

- Abbe's Condenser for Microscope, *532
 — Apochromatic Objectives, 527
 Aberration of Lens (Glossary), ix.
 Abney on Colour Intensities, 440
 — Colour Photography, 420
 — Sensitometer, 455
 — on Density, 398
 — Experiments by, 391, 398, 399
 — Method of Removing Colour Fog, 140
 — on Optical Sensitisers, 393
 — Orthochromatism, 445
 — Oxy-chloride Theory, 409
 — Photographic Definition, 387
 — Rule in Pinhole Photography, 295
 — Screen, 418
 — on Spectrophotographic Plates, 566
 — Tentative Development, 117
 Accelerator (Glossary), ix.
 — for Pyro Developer, 108
 Accretion (Glossary), ix.
 Acetaldehyde, 458
 Acetate of Soda Toning Bath, 246
 Acetic Acid (Glossary), ix., 458
 Acetone (Glossary), ix.
 Acetylene or Ethine (Glossary), ix.
 — Lamp for Photomicrography, 518
 — for Portraiture, 478
 Achromatic (Glossary), ix.
 — Objectives for Microscope, 525-527
 Acid (Glossary), ix.
 — Fixing Bath (Glossary), ix.
 Acres' Cinematograph, 665
 Acridine (Glossary), ix.
 Acrograph (Glossary), ix.
 Actinic Light, Reducing Effect of, 222
 Actinism (Glossary), ix., 2
 — Charles' Discoveries in, 3
 — Discovered by Fabricius, 3
 — First Recorded Experiments in, 3
 — Fischer's Discoveries in, 3
 — Ritter's Discoveries in, 3
 — Scheele's Discoveries in, 3
 — Senebier's Discoveries in, 3
 Actinium, 709
 Actinograph (Glossary), ix.
 — Hurter and Driffield, 106, 419
 — Speed of Plate, 419
 Actinometer (Glossary), ix., 189
 — for Dusting-on Process, *203
 — for Testing Light, 100
 — Johnson's, 189
 — Simple, 190
 — Using, 189, 190
 — Workins', 190-102
 — Wynne's, *189
 Adams' "Kenil" Hand Camera, *501
 — "Videx" Hand Camera, *502
 Adapter for Lenses (Glossary), ix.
 — Stereoscopic, *618, *619
 Adon (Glossary), ix.
 — Telephoto Lens, *369, 370, 650
 Adulor (Glossary), x.
 — Developer, 112, 113, 399
 — Factor of, 116
 Aerial Perspective (Glossary), x.
 Aërograph or Air-brush (Glossary), x., *355
 Agar-agar (Glossary), x.
 Airbells (Bubbles) (Glossary), x.
 Air-brush (Glossary), x., *355
 Air-bubbles on Plates, 127, 128
 — "Akuret" Print Meter, *190
 Alabastrine Process (Glossary), x.
 Albert's Collotype Process, 678
 — Half-tone Process, 697
 Albumen (Glossary), x., 462
 — Bubbles in, 169
 — Coagulating, 170
 — Coating Paper with, 168, 169
 — Mixing Chloride with, 168
 — Paper (Glossary), x., 403, 404
 — Action of Light on, 404
 — Fuming, *174
 — Permanency of, 249
 — Sensitising, 169-174
 — Strengths of Baths for, 169, 170
 — Testing Amount of Chloride in, 171
 — Toning, 249, 250
 — Plates, 83
 — Preparing, 167-170
 — Process, 167-170
 — Salting, 167, 168
 Albumen-beer Process (Glossary), x.
 Albums for Prints, 292
 Alcohol (Glossary), x.
 — Ethyl, 455-457
 Aldehyde, 457
 Aldis Stigmatic Lens, 374
 Algraphy (Glossary), x.
 Alizarin, 352
 Alkali (Glossary), x.
 Alpha Paper and Plates (Glossary), x.
 Alum (Glossary), x.
 — Bath before Toning, 242
 — Trough for Cinematograph, 672
 Aluminium (Glossary), x.
 — Chloride (Glossary), x.
 — Potassium Sulphate (Glossary), xi.
 "Al Vista" Panoramic Hand Camera, 503
 Allyl Sulphurea or Thiosinamine (Glossary), xxxviii.
 Allyl-thiocarbamide or Thiosinamine (Glossary), xxxviii.
 Amber (Glossary), xi.
 Ambrotype (Glossary), xi.
 American Etching Ink, 698
 — Lenticular Stereoscope, *627
 Amido Carboxylic Acid, 460
 Amido-benzene (Aniline) (Glossary), xii.
 Amido-phenolic Carbon Compounds, 465, 466
 Amidol (Glossary), xi., 467
 — Developer, 111, 399
 — for Bromides, 229
 — Factor of, 116
 Ammonia (Glossary), xi.
 — Intensifier, 402
 — Iron Alum (Glossary), xi.
 Ammonia-fuming (Glossary), xi.
 Ammonia-meter (Glossary), xi.
 Ammonio-citrate of Iron (Glossary), xi., xx.
 Ammonio-ferric Citrate in Platinotype Process, 206
 Ammonio-oxalate of Iron (Ferric) (Glossary), xx.
 Ammonium Bichromate (Glossary), xi.
 — Bromide (Glossary), xi.
 — Carbonate (Glossary), xi., 103
 — Chloride (Glossary), xi., 166
 — Iodide (Glossary), xi.
 — Nitrate (Glossary), xi.
 — Oxalate (Glossary), xi.
 — Persulphate (Glossary), xi.
 — Reducer, 140, 142
 — Sulphide (Glossary), xi.
 — Sulphocyanate (Glossary), xi.
 — Sulphocyanide (Glossary), xi.
 Amory, Dr., 388, 389
 Amphitype (Glossary), xi.
 Amyl-acetate (Glossary), xi.
 — Lamp (Glossary), xi.
 Anaglyph (Glossary), xi., 650
 Anastigmatic Lens (Glossary), xii., 563
 Anderson's Stereoscopic Projection, 632
 Angel Picture, *161, 162
 Angle of View (Glossary), xii.
 Angol (Glossary), xii.
 Angular Aperture (Glossary), xii.
 Anhydrous (Glossary), xii.
 Aniline, Amido-benzene, or Phenylamine (Glossary), xii.
 Animal Charcoal (Glossary), xii.
 — Photograph, 639, 640
 — Apparatus for, 641, 642
 — Aquarium for Fish Subjects, 645
 — Beetles, 645
 — Birds, 641, 642
 — Camera for, 641, 642
 — Disguising Camera, 642
 — Fish, 645, 644
 — Focal Plane Shutter for, 640
 — Insects, 644, 645
 — Kearton Brothers and, 641
 — Lenses for, 640
 — Lizards, 642
 — Plates for, 641
 — Reptiles, 642, 645
 — Treatment of Animals, 641
 — Washing Fish, 645, 644
 Animals and Portraiture, 482, 485
 Animated Photographs in Book Form, 675
 — Photography, *664-675
 — Animatograph, 665
 — Biograph, 665, 670
 — Biopticon, 671
 — Birtac, 671
 — Camera for, 665

- Animated Photography: Chrono-
photographie, 665, 670
—: Cinematograph, 664, 665
—: Cynograph, 671
—: Developing Negative
Film, 666
—: Positive Film, 667
—: Exposure for, 665, 666
—: Gaumont Chrono Camera
for, 665
—: Hints on Exhibiting, 671
—: Hughes' Bio-pictoro-
scope, 671
—: Hughes' Roto-bioscope,
671
—: Illuminant for, 672, 673
—: Intermittent Cinemato-
graph, Mechanism of, 668
—: Jenkins' Printing Ar-
rangement for, 667
—: Kammatograph, 671
—: Kinetoscope, 665
—: Lumière Cinematograph,
670, 671
—: Making Positive Film,
666, 667
—: Trick Films, 667, 668
—: Moto Bijou Camera, 671
—: Motograph, 671
—: Motograph, 670
—: Nemst-Paul High-power
Lamp for, 672
—: Paul's Reliance Anima-
tograph, 668, 669, 670
—: Persistence of Vision, 664
—: Proschwich Junior
Camera, 671
—: Projection Apparatus,
668
—: Rapid Production, 667
—: Reducing Vibration and
Flickering in, 673
—: Taking Picture, 666
—: Theatograph, 665
—: Use of Alum Trough,
672
—: Vitagraph, 671
—: Warwick Bioscope, 671
—: Watson's Motograph, 671
—: Stereograms, 657
Animatograph, 665 (see also Cino-
matograph)
—: Paul's Reliance, 665, 668-670
Anschutz Tachyscope, 664
Anthon (Glossary), xii.
Anthony's Bioptricon, 671
Anthrakotype (Glossary), xii.
Antiplanat (Glossary), xii.
Antwerp Blue, 352
Aperture (Glossary), xii., 375
— of Telephoto Lens, 649, 650
Aphescope (Glossary), xii.
Aplanatic Lens (Glossary), xii., 365
Aplanatic Lens (Glossary), xii.
— Objectives for Microscopes,
527
Apothecaries' Weight, 718
App's System of Radiography, 703
Aqua Fortis (see Nitric Acid)
— Regia (Glossary), xii.
Aquatint (Glossary), xii.
Arc Lamp, Double Carbon, 694
—: Making, 585
Architectural Photography, 551-554
—: Apparatus for, 551, 552
—: Camera for, 551, 552
—: Exposure for, 554
—: Lens for, 553, 554
—: Lighting for, 554
—: Use of Levels in, 552
—: Voigtlander Euryscope
for, 553
Argentometer (Glossary), xii., 175
Argus Camera, 639
Aristogen (Glossary), xii.
Aromatic Carbon Compounds, 463
Arrowroot (Glossary), xii.
Arrigue Process, 200
Artograph (Glossary), xii.
Artotype (Glossary), xii.
Asphalt, Solubility of, 4
Asphaltum (see Bitumen)
Aspirator (Glossary), xii.
Aspray and Stereo-Anima-Photo-
graphy, 652
Astigmatism (Glossary), xii., 356
—: Testing Lens for, 35
Astronomical Photography, 594-
611
—: Calculating Magnifica-
tion, 601
—: Chromosphere, 603
—: Comets, 611
—: Coronagraph for, 610
—: Coronal Appendage, 602
—: Davis', 602
—: Direction of Telescope,
597-599
—: Doppler's Principle, 608
—: Eclipses, 609, 610
—: Elimination, 599, 600
—: Fixing Camera for, 597
—: Hydrogen Lines in, 608
—: Inverted Image, 594, 595
—: Lightning, 611
—: Moon, 605, 606
—: Nebulae, 611
—: Object Glass for, 595
—: Ramsden's Eyepiece,
598, 599
—: Ring Spectra, 603
—: Siderostat, 600
—: Solar Prominences, 604
—: Spectroscopic Pheno-
mena in, 608
—: Spectrum Heliograph
for, 607
—: Spot Spectra in, 608
—: Star Photographs, 606
—: Sun Photography, 600-
604
—: Telescope Finder for,
596, 597
—: Telescopes for, 594-596
—: Tennant's, 602
—: Velocity Measurements,
609
—: Telescopes, 594-596
Astro-photography (Glossary), xii.
Atmospheric Influences on Expo-
sure, 87
—: Perspective, 498
Aurantia (Glossary), xii.
Aureolin, 352
Aurin or Corallin (Glossary), xii.
Aurora Yellow, 352
Autocopyist, Photo, 677
Autolyphic Process (Glossary),
xii.
Automatic Photography (Glossary),
xii.
—: Stereoscope, 628
Autotype (Glossary), xii.
Avoirdupois Weight, 718
Axial Accommodation of the Eye
(Glossary), xii., 612-613
- B**
- Back (see Reversing Back, Revolv-
ing Back, Rotating Back, Swing
Back)
—: Focus (Glossary), xiii., 360
Background (Glossary), xiii.
—: Chalk, in Enlargements, 354
—: Colouring, 344
—: Insertion (see Plate 14)
—: Introducing, into Portrait, 159
—: for Monumental Work, 588
—: Painted, for Enlargements, 351
—: in Portraiture, 471, 472, 479
Backing (Glossary), xiii., 555
—: for Opalines, 283
Badger Hair Softener for Painting,
348
Baker on Oxy-chloride Theory, 408
Baker's D.P.H. Microscope, 523
—: Oxycalcium Apparatus, 315
Balance (Glossary), xiii.
—: in Landscape Photography, 496
—: Dark-room, 270
Balloon Photography (Glossary),
xiii.
Baptista Porta Camera Obs-cura, 2
—: Lens, 362
—: and Pinhole Photogra-
phy, 294
Bar Burnisher for Prints, 283, 284
Barium Chloride (Glossary), xiii.
—: Nitrate (Glossary), xiii.
—: Platino-cyanide Screens, 704
—: Sulphate (Glossary), xiii.
Barker's Printing-out Emulsion,
175
—: Extra Rapid Plates, 99
Barlow Telephoto Lens, 646
Barnard and Gowenlock's Patent
Kromaz, 427, 428
Barnet Ordinary Plates, 99
—: Rapid Plates, 99
—: Rocket Plates, 99
Baseboard for Stereoscopic Camera,
616
Baskett's Pinhole Work, 299
—: Reducer, 139
Bas-relief Photographs (Glossary),
xiii.
Bates' Black, 187
Baths, Old Fixing, Treatment of,
676
Bausch and Lomb Photomicro-
graphic Camera, 540, 541
—: Ray Filter, 446
Beale's Reflector for Photomicro-
graphy, 512
Beauregard's Colour Photography,
420
Beck Biplanat Lens, 366
—: Multiflex Telephoto Lens, 650
—: Photomicrography Apparatus,
516
—: Telephoto Lens, 650
Beck-Steinhil Orthostigmat Lens,
367
Bequerel's Colour Photography,
420
—: Experiments, 391
—: Radiography Experiments, 709
Beetles, Photographing, 645
Beginner's Photographic Outfit, 24
Belitzki's Reducer (Glossary),
xiii., 141
Bellows (Glossary), xiii.
—: Making, 712
Benches, Dark-room, 265, 264
Bennett, Charles, 6
Bennetto Colour Photography, 438
Benzene or Benzol (Glossary), xiii.,
463-465
Benzine, 465
Benzol (see Benzene)
Benzoline or Petroleum Spirit
(Glossary), xiii.
Berghelm Lens (Glossary), xiii., 365
Beveller, Royle's Lining, 700
Bevelling Margins of Half-tone
Blocks, 689
Bicarbonate and Acetate of Soda
Toning Bath, 246, 247
— of Soda Toning Bath, 246
Bichromate Disease, 194
— of Potash or Potassium Di-
chromate (Glossary), xxxii.
—: Lamps, Dark-room, 266
Bichromated Gelatine (Glossary),
xiii.
—: Experiment with, 186
Biconcave Lens (Glossary), xiii.
Biconvex Lens (Glossary), xiii.
Binder (Glossary), xiii.
Binding for Lantern Slide, 321
—: Stereoscopic Transparencies,
626

- Bingham and the Introduction of Collodion, 6
- Binoocular Camera (Glossary), xiii.
- , Goerz Stereo, *506
- , Hand Camera, *505
- , Perception and Stereoscopic Photography, 615
- , Vision, *613, *614
- , Watson's Stereoscopic, 505
- Biograph, Casler's, 670
- , Demeny's, 665
- Bio-pictoscopic, 671
- Biopicon, Anthony's, 671
- Bioscope, Warwick, 671 (see also Cinematograph)
- Biplanar (Group) Lens, 368
- Birdland Camera, 639, 640
- Birds, Photographing, 641, 642
- Birds' Nests, Photographing, 641
- Birtae Animated Photography Apparatus, 671
- Bitumen (Glossary), xiii.
- , Half-tone Process, 698
- , Niepce's Application of, 4
- , of Judea, Solubility of, 4
- , Process (Glossary), xiii.
- Blackening Negative, 133
- Black Enamel, 654, 655
- , for Bellows, 714
- , Brasswork, 714
- Blanchard's Brush (Glossary), xiii.
- Blanquet-Evrard, 6
- Bleaching Effect on Colours, 388
- , Negative, 132, 135
- , Powder (Chloride of Lime) (Glossary), xv.
- Bleaching-out Process of Colour Photography, 435, 436
- Blind Shutter (Glossary), xiii.
- Blinds for Studio, *470, 471
- Blistering (Glossary), xiii., 238
- Block Making (see Photo-mechanical Processes)
- Blocking Out (Glossary), xiii.; Plate 14
- Blue-printing Process (Glossary), xiii.
- Blurring (see Halation)
- Bolometer for Spectrophotography, 566
- Bolton, W. B., 6, 7
- Book Form, Animated Photographs in, 673
- Border Vignettes, 158
- Borders in Mounts, 282
- , for Opalines, 283
- Borax (Glossary), xiii.
- , Solution for Photo-ceramics, 655
- Botanical Photographs, 658
- Bothamley on Stains, 257
- , on Dyes, 389
- Bottle Imp Photographs, 718
- Brass, Etching, 697
- Brasswork, Blacking, 714
- Breath Printing (Glossary), xiii.
- Brenzatechin (see Pyrocatechin)
- Brewster's Stereoscope, *627
- British Gum (Glossary), xviii.
- Bromide Enlargements, *232—234
- , Gas-light Papers, 235
- , Developing, 235
- , Fixing, 235
- , Tones of, 235
- , Paper (Glossary), xiv.
- , Carbon Velox, 225
- , Cutting, 222
- , Developers, 228
- , Amidol, 229
- , Eikonogen, 229
- , Ferrous Oxalate, 229
- , Hydroquinone, 228
- , Metol, 228, 229
- , Metol-hydroquinone, 228
- , Temperature of, 230
- , Distinguishing Sensitive Side of, 222, 223
- Bromide Paper, Kodak Rapid, 225
- , Lengths, Frame for, 218
- , Pins, 313
- , Preparation of, 213
- , for Radiographs, 708
- , Sensitiveness of, 225
- , Printing Apparatus, *217
- , Buckle Brush used in, 230
- , Candle Light for, 220
- , Chemistry of, 404
- , Combination Printing, 226, 227
- , Daylight for, 221
- , Dodging, 226
- , Electric Light for, 221
- , Exposures for, 223, 224
- , Exposure-timing Device for, 224
- , Frames, *217
- , Gas Light for, 221
- , Illuminants for, 220, 221
- , Influence of Strength of Light, 226
- , Method of Exposure in, 225, 226
- , Multiple, *218
- , Negative for, 220
- , Oil Lamp Light for, 220
- , Vignetting, *227, 228
- , Masks, 227
- , Prints (see Plate 17)
- , Acid Bath for Fixing, 231
- , Alum Bath for, 231
- , Black Lines in, 238
- , Blisters in, 238
- , Development of, 229, 230
- , Drying, 232
- , Excessive Contrast, 237
- , Final Washing of, 231
- , Fixing, 231
- , Flatness in, 237, 238
- , Fog in, 237
- , Mounting, 232
- , Patchiness in, 238
- , Permanency of, 213
- , Sepia, 234, 235
- , Solution of Deposit, 238
- , Spots in, 238
- , Stained High Lights in, 238
- , Removing Stains from, 238
- , Toning, 234
- , in Colours, 236, 237
- , Uranium Process for, 236
- , Yellow Stain in, 238
- , Process, 212—236
- , Advantages of, 212
- , Disadvantages of, 212, 213
- , Rapid Printing Devices, 218
- Bromide (Glossary), xiv.
- Bromine Halogen, 390
- Bromo-iodide of Silver (Glossary), xiv.
- Bromo-iodising in Half-tone Process, 695
- Bronzing (Glossary), xiv.
- Brown's Cinematograph Oscillating Attachment, *637
- , Stereo-photoduplicon, 620, 621
- , Stereoscopic Adapter, 619
- , Projection, *634—636
- , Transmitter, *619
- Brush, Blanchard's (Glossary), xiii.
- , Buckle (Glossary), xiv., *230
- , for Water Colours, *339
- Bubbles and Air-bells (Glossary), x., 127, 128
- Buckle Brush (Glossary), xiv., 230
- Bunsen Burner (Glossary), xiv.
- Burgess Gelatine Plate, 6
- Burners, Oil Lamp, 517
- Burning-in of Plates, 696
- Burnisher (Glossary), xiv.
- , Bar, *283, 284
- , Roller *284—296
- , Using, 284, 285
- Burnishing Prints, *283, 285
- Burnt-in Photograph (Glossary), xv.
- Busch Freewheel Camera, 509
- Buttons, Photographic, 198

C

- Cabinet (Glossary), xiv.
- Cabinets, Cutting Paper for, *122
- Cadet's Lightning Plates, 99
- , Ordinary Plates, 99
- , Spectrum Colour Plates, 425
- Cadet's Table of Plate Speeds, 413
- Cadet and Neall's Orthochromatic Plates, 452
- Cadmium Bromide (Glossary), xiv.
- , Iodide (Glossary), xiv.
- , Yellow, 352
- Calcium Carbide (Glossary), xiv.
- , Chloride (Glossary), xiv.
- , Tube (Glossary), xiv.
- , Tungstate Screens, 704
- Calotype (Glossary), xiv.
- , Process, 5
- Camel-hair Mop for Colouring, *340
- Cameo (Glossary), xiv.
- , Camera, 510
- Camera (Glossary), xiv.
- Camera, Adams' "Koni," *501
- , "Videx" Hand, *502
- , "Al Vista" Panoramic, *503
- , for Animal Photography, 641
- , Animated Photography, 665
- , Architectural Photography, 551, 552
- , Argus, 639, 640
- , Automatic Ferrotypes, *47, *49
- , Bellows, Making, *712
- , Binoocular (Glossary), xiii., 505
- , Birdland, 639
- , British Ensign, 503
- , Busch Freewheel, 509
- , Cameo, 510
- , Carbine, 510
- , Care of, 29
- , Century, 510
- , Challenge, 509
- , Chevalier's, 362
- , Cinematograph, for Stereoscopic Photography, 636
- , Clement and Gilmer, 509
- , Cloth (Glossary), xiv.
- , for Copying, *39
- , Dagnier, 362
- , Dallmeyer, 510
- , Dallmeyer's Naturalists' Hand, 640
- , "Dalo," *503, 504
- , Distance of Object from, 89
- , Enlarging, *39—45
- , Base for, 41
- , Bellows for, 42
- , Camera Front for, 42
- , Dark Slide for, 45
- , Focussing Screen for, 45
- , Ernemann, 509
- , Falloroll, *502, 503
- , Ferrotypes, 47—50, 119
- , Dark Slide and Rails for, 49
- , Making, 48—50
- , Plate Wires for, 49
- , Toprail for, 48
- , Field, with High Rise of Front, 26
- , Long Extension, 26
- , with Roller Blind Shutter, 26
- , Focoplane, 510
- , Focussing Hand, *27
- , Graduating Scale of, *373
- , Focussing Screen, 12
- , Folding, for Films, *27

- Camera, Folding, for Plates, 27
 ---, with Pneumatic Release, *27
 ---, Pocket Cyko, *505
 ---, for Half-tone Process, 689
 ---, Frena, *508
 ---, Gaumont's Chrono, 665
 ---, Goerz-Anschutz, 509
 ---, Hand, *26
 ---, Iford, 509
 ---, Invincible, 510
 ---, Kodak, *505, 504
 ---, Lancaater Filmograph, 510
 ---, Landscape, *25
 ---, Lizars' Minor de Luxe, 552
 ---, Lucida, *512, 513
 ---, Mackenstein, 505
 ---, Magazine Hand, 27
 ---, Minimum Palms, 509
 ---, Miral Reflex, 509
 ---, Movements and Fittings, 25
 ---, Natti, *501, 502
 ---, Nattia, 502
 ---, for Natural History Photography, *639, 640
 ---, Newman and Guardia Reflex, *504, 505
 ---, --- Universal, 505
 ---, Obscura (Glossary), xiv, 2
 ---, ---, Baptista Porta's, 2
 ---, ---, Guyot's, 2
 ---, ---, Principle of, *31
 ---, ---, Perfection of, 8, 9
 ---, ---, for Photomicrography, 539-541
 ---, Planoflex, 510
 ---, Portable Enlarging, 40
 ---, Premo, 509
 ---, Prestwich Junior, 671
 ---, Primary Object of, 10
 ---, Primus, 510
 ---, Process, Base of, 890
 ---, ---, Copy Board of, 890
 ---, ---, Goerz Reversing Prism for, 695
 ---, ---, Mirror of, *695
 ---, ---, Prism for, 695
 ---, ---, Swing Base of, 690, 691
 ---, Reflector, 509
 ---, Reflex, *639, 640
 ---, Requirements of, 24
 ---, Rising Front (Glossary), xxxiv
 ---, Roll-holders, 58
 ---, Ross, 509
 ---, Sanderson, 505, 552
 ---, Shutters, *54-57 (for details see Shutters).
 ---, Sickle, 510
 ---, Simplest Form of, 10
 ---, Size of, 25, 26
 ---, Sliding Front for Stereoscopic Photography, 44
 ---, Solo, 509
 ---, Solar (Glossary), xxxvi
 ---, Square Bellows Field, 25
 ---, Stands, *50
 ---, ---, for Architectural Work, *54
 ---, ---, Featherweight, *50
 ---, ---, Studio (see Studio)
 ---, ---, Telescopic, *54
 ---, ---, Turntable for, *50
 ---, ---, Walking Stick, *54
 ---, ---, Stereo-cinematograph, 633
 ---, ---, Stereoscopic, 45, *547, 616-620
 ---, ---, Back Frame and Swing Back for, *46
 ---, ---, Baseboard and Extension for, 45
 ---, ---, Division for, 47
 ---, ---, for Field Use, *44
 ---, ---, Focussing Screen of, 46
 ---, ---, Frontboard Frame for, 45
 ---, ---, Making, *45, 47
 ---, ---, Reversing Back of, 46
 ---, ---, Sliding Body of, 45
- Camera, Studio, 37
 ---, ---, Back Frame for, 38
 ---, ---, Baseboard of, 37
 ---, ---, Clamping Rails for, *38
 ---, ---, Extension Frame for, *38
 ---, ---, Focussing Screen Frame for, *38
 ---, ---, Making, 37
 ---, ---, Reversing Back for, 38
 ---, ---, Rising Front Board of, 38
 ---, ---, Sliding Frame for, *37
 ---, ---, ---, Front of, 38
 ---, ---, Slotted Rail for, *37
 ---, ---, Suter, 509
 ---, ---, Swing Back, 12
 ---, ---, "Takuquick" Ferrotypes, 119
 ---, ---, Teb, 510
 ---, ---, Telephoto Cornex, *503
 ---, ---, Tella, 509
 ---, ---, Thornton-Pickard Automan, 509
 ---, ---, Tilting Board for, *54
 ---, ---, Underwood Foldette, 509, 510
 ---, ---, Verascope, *505
 ---, ---, Videx, *502
 ---, ---, View-finders, *59
 ---, ---, Voigtländer Brunswick, *507
 ---, ---, ---, Favourite, 507
 ---, ---, ---, Heliar, 507
 ---, ---, Yril, 509
 ---, ---, Wet-plate, 47
 ---, ---, Wizard, *502
 ---, ---, Xit, 509
 ---, ---, Zambon, 509
- Cameras, Duplicate, for Stereoscapy, 621
 ---, Camphor (Glossary), xiv
 ---, ---, Canada Balsam (Glossary), xiv
 ---, ---, Candle Lamps, Dark-room, *265
 ---, ---, Cannon-ball, Speed of, 105
 ---, ---, Cantilever Enlarging Lantern, *306
 ---, ---, Canvas, Mounting on, 287
 ---, ---, ---, Printing on (Glossary), xiv
 ---, ---, (caoutchouc (see India-rubber))
 ---, ---, Cap (Glossary), xiv
 ---, ---, Cappagh Brown, 352
 ---, ---, Caramel (Glossary), xiv
 ---, ---, Carbine Camera, 510
 ---, ---, Carbolic Acid, or Phenol (Glossary), xiv, 464
 ---, ---, Carbon Arc Lamp, 694
 ---, ---, ---, Compounds: Acetaldehyde, 458
 ---, ---, ---, Action of Light on Ferric Oxalate, 459
 ---, ---, ---, Albumen, 462
 ---, ---, ---, Amido Carboxylic Acids, 469
 ---, ---, ---, Amidol, 467
 ---, ---, ---, Amido-phenolic Substances, 465, 466
 ---, ---, ---, Aromatic, 465
 ---, ---, ---, Benzene, 463, 464
 ---, ---, ---, ---, Derivatives, 464
 ---, ---, ---, Benzine, 463, 464
 ---, ---, ---, Carbolic Acid, 464
 ---, ---, ---, Celluloid, 462
 ---, ---, ---, Cellulose, 460, 461
 ---, ---, ---, ---, Nitrates, 461
 ---, ---, ---, Chemistry of, 454-468
 ---, ---, ---, Classification of, 454, 455
 ---, ---, ---, Collodion, 461
 ---, ---, ---, Complex Organic, 460
 ---, ---, ---, Constitutional Formulae for, 455
 ---, ---, ---, Cyclic, 463
 ---, ---, ---, Di-amido-phenols, 466
 ---, ---, ---, Di-carboxylic Acids, 459
 ---, ---, ---, Di-hydric Phenols, 464
 ---, ---, ---, Eikonogen, 467, 468
 ---, ---, ---, Emissions, 462
 ---, ---, ---, Ethyl Alcohol, 455-457
 ---, ---, ---, Fatty, 454, 455
 ---, ---, ---, Formaldehyde or Formalin, 457
 ---, ---, ---, Formic Acid, 459
 ---, ---, ---, Gelatine, 462, 463
- Carbon Compounds: Glacial Acetic Acid, 458
 ---, ---, Gum-cotton, 461
 ---, ---, Henna, and, 454
 ---, ---, Hydroquinone, 465
 ---, ---, Hydroxyl, 455, 456
 ---, ---, Hydroxy-tri-carboxylic Acids, 460
 ---, ---, Identifying, 455
 ---, ---, Isomeric, 455
 ---, ---, Isomeric Di-substitution Products, 464, 465
 ---, ---, Ketones, 460
 ---, ---, Methyl Ether, 455
 ---, ---, Metol, 467
 ---, ---, Molecular Formula for, 455
 ---, ---, Mono-carboxylic Acid, 458
 ---, ---, Naphthalene, Naphthol, etc., 467
 ---, ---, Nitro Cellulose, 461
 ---, ---, Open Chain, 454, 455, 457
 ---, ---, Organic, 456
 ---, ---, Organic Acids, 458
 ---, ---, Phenol, 464
 ---, ---, Polymerism, 457, 458
 ---, ---, Pyrogallol, 465
 ---, ---, Pyroxyline, 461
 ---, ---, Radicals, 456
 ---, ---, Rodinal, 466
 ---, ---, Sensitisers, 460
 ---, ---, Test for Furfural, 459
 ---, ---, Tri-hydroxy Derivatives of Benzene, 465
 ---, ---, ---, Wohler and, 454
 ---, ---, Disulphide (Glossary), xv
 ---, ---, Paper (Glossary), xv
 ---, ---, ---, Coating, *192
 ---, ---, Print, Developing, 190, 191
 ---, ---, ---, Enamelling, 197, 198
 ---, ---, ---, Finishing off, 191
 ---, ---, ---, Intensifying, 198
 ---, ---, ---, Mounting, 190, 191
 ---, ---, ---, Permanency of, 186
 ---, ---, ---, Pressing, 190, 191
 ---, ---, ---, Red Chalk (see Plate 1)
 ---, ---, ---, Process (Glossary), xv, 186-189 (see also Gum Bichromate, Artigue, Carbon Velours, and Ozotype)
 ---, ---, ---, Actinometers for, 189
 ---, ---, ---, Chemical Aspects of, 187
 ---, ---, ---, Defective Negatives, 195
 ---, ---, ---, Double Transfer, 186, 197
 ---, ---, ---, Exposure of Negative in, 189
 ---, ---, ---, adapted for Photo-ceramics, 656
 ---, ---, ---, Mungo Ponton and, 186
 ---, ---, ---, Outfit, 188
 ---, ---, ---, Poncey's, 198
 ---, ---, ---, Principle of, 186, 187
 ---, ---, ---, Printing Negative in, 188, 189
 ---, ---, ---, Safe-edging Negative in, 187, 188
 ---, ---, ---, Single Transfer, 187-196
 ---, ---, ---, Swan's Introduction of, 186
 ---, ---, ---, without Transfer, 198
 ---, ---, ---, Tissue, 188
 ---, ---, ---, Case for, *183
 ---, ---, ---, Chromatic Salts for Sensitising, 193, 194
 ---, ---, ---, Colouring Pigment for, 192
 ---, ---, ---, Drying, 195
 ---, ---, ---, Cupboard for, *195
 ---, ---, ---, Gelatine for, 191, 192
 ---, ---, ---, Immersing, 194
 ---, ---, ---, Keeping Qualities of, 195
 ---, ---, ---, Sensitising, 192, 195
 ---, ---, ---, for Single Transfer Process, 191
 ---, ---, ---, Squeegee for Stroking, 190
 ---, ---, ---, Stroking, *190

- Carbon Tissue Supports, Double Transfer, 195
 ———, Single Transfer, 195
 ———, Temporary, 195
 ———, Waxing, 195
 ———, Testing, 195
 ———, Various Supports for, 197
 ———, Transparencies, 197
 ———, Intensifying, 197
 Carbonate, Ammonium, 108
 ———, Potassium, 108
 ———, Sodium, 108
 Cardboard Bellows, Making, 712
 ———, Screens for Radiography, 705
 ———, Vignetter, 155
 Caricature Photographs, 716
 Carrier (Glossary), xv.
 Carte-de-visite (Glossary), xv.
 Cartridge (Glossary), xv.
 Casler's Biograph, 670
 Cassegrain's Telescope, *596
 Caustic Lithia (Lithium Hydrate) (Glossary), xxvi.
 ———, Potash (see Potassium Hydrate)
 ———, Soda (see Sodium Hydrate)
 ———, or Sodium Hydrate (Glossary), xxxvi.
 Celestial Sphere and Astronomical Photography, *597-598
 Cellar as Dark Room, 261
 ———, Ventilation of, *261
 Celloidin (Glossary), xv.
 Celluloid (Glossary), xv., 462
 ———, Cement for Films, 675
 ———, Film (Glossary), xv.
 ———, Mutoscope, 675
 Cellulose (Glossary), xv., 460, 461
 ———, Nitrates, 461
 Cement for Animatograph Films, 675
 Centrifugal Separator (Glossary), xv.
 Century Camera, 510
 Ceramic Enamels, Morgan and Kidd's, 653
 ———, Photograph, Enamel, Burnt in, or Photo-ceramic (Glossary), xv. (see also Photo-ceramics)
 Cerium Sulphate, or Ceric Sulphate (Glossary), xv.
 Cerulean Blue, 352
 Chair, Posing, *481
 Chalk Backgrounds in Enlargements, 354
 ———, or Calcium Carbonate (Glossary), xv.
 Chalkiness (see Hardness)
 Challenge Camera, 509
 Changing-bag (Glossary), xv.
 Changing-box (Glossary), xv., *28
 Charcoal, Animal (Glossary), xii.
 Charles' Experiments in Actinism, 3
 Cheeks, Colouring, 345
 Chemical Balance, 62
 ———, Focus (Glossary), xv.
 ———, Fog (Glossary), xv.
 Chevalier's Cameras, 362
 Chiaroscuro (Glossary), xv., 497
 ———, in Portraiture, 464
 Children in Portraiture, 482, 483
 Chili Saltpetre, or Sodium Nitrate (Glossary), xxxvi.
 China Clay (Kaolin) (Glossary), xxv.
 ———, Photography, 653-663 (for details see Photo-ceramics)
 ———, Photo-ceramics, 662, 663
 Chinese White, 352
 Chinoline (Cyanine) (Glossary), xviii.
 Chloride, Ammonium, 166
 ———, of Lime (Glossary), xv.
 ———, ———, and Chalk Toning Bath, 247
 ———, Plates (Glossary), xv.
 ———, of Silver, Recovering, 674, 675
 Chloride, Testing amount of, in Printing Paper, 171
 (Chlorine (Glossary), xv.
 ———, Halogen, 390
 (Chloroform (Glossary), xv.
 Chlorophyll (Glossary), xv., xvi.
 Chromatic Aberration (Glossary), xvi., 355
 ———, Test for, 34
 ———, Plates, 87
 Chrome Alum (see Alum)
 ———, Green, 352
 ———, Lemon, 352
 ———, Orange, 352
 ———, Red, 352
 ———, Yellow, 352
 Chromium Potassium Sulphate (Glossary), xvi.
 Chromosphere; Astronomical Photography, *603
 Chronophotographie, 665
 Chryso-sulphite (Glossary), xvi.
 Chryso-Developer, 128
 Chryso-type Process, 206
 Chryso-type (Glossary), xvi. (see also Animated Photographs)
 ———, Birt Acres and, 665
 ———, Camera, Brown's Oscillating Attachment for, 637
 ———, ———, for Stereoscopic Photography, 636
 ———, Films, Care of, 673
 ———, Cement for, 675
 ———, Colouring, 675
 ———, Developing, *123
 ———, Joining, 675
 ———, First, 664, 665
 ———, Friese-Greene and Evans, 664
 ———, Intermittent Mechanism of, 663
 ———, Lumière, 665, 670, 671
 ———, Lens, *370
 Cinematography, Stereoscopic, 653
 Cinnabar Green, 352
 Circular Prints, Trimming, *276
 Cisterns, Dark-room, *272
 Citric Acid (Glossary), xvi.
 Citro-chloride Process, 179, 180
 Citron Yellow, 352
 Clamp for Lantern Slide, *321
 Clearing Solution (Glossary), xvi.
 ———, as Reducer, 142, 143
 Clement and Gilmer Camera, 509
 ———, Viatragraph, 671
 Clerk-Maxwell's Colour Processes, 424, 425
 Clip for Prints, *246
 Clock, Dark-room, *117
 Cloud Negatives, Choice of, 161
 ———, Vignettes, 157
 Clouds in Landscape Photography, 498
 ———, Lantern Slide, 323
 ———, Printing in, *226
 Coating Plates, Whirlor for, 696
 ———, Tiles and Plaques with Col-Iodine, 655
 Cobalt (Glossary), xvi.
 ———, Blue, 352
 Coins, Radiographs of, 709
 Colas's Process (Glossary), xvi.
 Collinear (Glossary), xvi.
 Collodio-albumen Process (Glossary), xvi.
 Collodio-chloride, Coating Paper with, 170
 ———, Formulae for, 178, 179
 ———, Paper (Glossary), xvi.
 ———, Action of Light on, 404
 ———, Process, 178
 Collodio-gelatine Emulsion (Glossary), xvi.
 ———, Simpson's Formula for, 178
 Collodion (Glossary), xvi., 73, 461
 ———, Bath, Purifying, 79
 ———, Bottles, 76
 ———, Bromising, 74
 ———, Coating Plates with, 78, 81
 Collodion Developers, 79
 ———, Dry-plates, 82, 695
 ———, Finishing, 83
 ———, Intensifying, 137
 ———, Introduction of, 6
 ———, Emulsion, 6, 695
 ———, Film, Exposure of Unfixed, 137
 ———, for Half-tone Process, 694, 695
 ———, Home-made, 81
 ———, Iodising, 74
 ———, Preparation of, 74
 ———, Process, Apparatus for, 75
 ———, Cleaning Plates for, 76
 ———, Defects of, 79
 ———, Edging Plate for, 77
 ———, Exposure of Plate, 79
 ———, Scott-Archer's, 6
 ———, replaced by Gelatine, 6
 ———, Sensitisers, 6
 ———, Silver Bath for, 75
 ———, Wet, 75-79
 ———, Transfers (Glossary), xvi.
 ———, Wet-plates, Exposing, 77, 78
 ———, Intensifying, 136, 137
 ———, Schlippe's Salt Intensifier for, 137
 Collotype (Glossary), xvi.
 ———, Plates, Coating, with Substratum, 679
 ———, Developing, 680
 ———, Dry Photo-mechanical, 683
 ———, Drying Oven for, *679
 ———, "Etch" for, 680, 681
 ———, Exposing, 680
 ———, Levelling Screws for, *679
 ———, Tripod for, *679
 ———, Preparing, 678, 679
 ———, Sensitising, 679
 ———, Process, 677-683
 ———, Albert's, 678
 ———, Dry Plates for, 633
 ———, Husnik's, 678
 ———, Inking-up in, 682
 ———, Liesegang's, 683
 ———, Machines for, 681
 ———, Maréchal's, 678
 ———, Motay's, 678
 ———, Ohm and Grossman's, 678
 ———, Poitevin's, 678
 ———, Presses for, *681, 682
 ———, Pretsch's, 678
 ———, Proper, 678
 ———, Simple form of, 677, 678
 ———, Simon, 682, 683
 Colour Combination, Illustration of, *358
 ———, Fog, or Dichroic Fog (Glossary), xviii.
 ———, Method of Removing, 140
 ———, Intensities, Measurement of, *440
 ———, Photography (Glossary), xvi., 420-438
 ———, Abney's, 420
 ———, Beauguard's, 420
 ———, Becquerel's, 420
 ———, Bennetto and, 438
 ———, Bleaching-out Process of, 435, 436
 ———, Clerk-Maxwell's, 424, 425
 ———, Collier's, 425
 ———, Cros, 423
 ———, Dansac-Chassagne, 438
 ———, Dichromatic, 425
 ———, Diffraction Grating Process of, *432-434
 ———, Florent's, 420
 ———, Half-tone Trichromatic, 436, 437
 ———, Hauron, 423, 458
 ———, Herschel's, 420
 ———, Hofmann, 438
 ———, Hunt's, 420
 ———, Ives', 425-428
 ———, Development in, 425
 ———, Exposure in, 425
 ———, Recording Colours in, 425-427

- Colour Photography, July, 429
 —: Koenig's Pinachromy, 437
 —, Kromaz Apparatus for, 428
 —, Lippmann's, 421-425
 —, Lumiere, 423, 424, 430, 431
 —, New, 431
 —, McDonough, 429
 —, Niepce St. Victor's, 420
 —: Photo-mechanical Work, 436-438
 —, Poitevin's, 420
 —, Powder Process of, 437
 —, Rothé's, 423
 —, Sanger-Shepherd, 429, 430
 —, Seebeck's, 420
 —, Szezepanik, 388, 423, 438
 —, Trichromic, 425
 —, Printing (see Plates 29-32)
 —, Rendering of Plates (see Plate 35)
 —, Screen (Glossary), xvii.
 —, Sensitizers, Dyes as, 441
 —, Sensitiveness (Glossary), xvii.
 —, of Plate, Increasing, 445
 —, Vision, Theory of, 424
 —, Wave-lengths, 354
 Colouring Animatograph Films, 675
 —, Background, 544
 —, Checks, 343
 —: Coating Print with Ox-gall, 341
 —, Drapery, 344
 —, Easel for, 340, 341
 —, Eyelashes, 343, 344
 —, Eyes, 343
 —, Face, 342
 —, Finishing Touches in, 344, 345
 —, Hair, 342, 343
 —, Harmony in, 337, 338
 —, Lantern Slides, 349-351
 —, Lips, 343
 —: Making Alterations, 344
 —, Mounting Print before, 340
 —, Ox-gall used in, 341
 —, Photographs, 337-352
 —, Preparing Print for, 341
 —, Print with Dyes, 351
 —, Prints Suitable for, 340
 Colours, Applying, 341, 342
 —, Brushes for, 339, 340
 —, Camel-hair Mop for, 340
 —, Gum Solution for, 340
 —, used in Painting, 347, 348
 —, Porcelain Tray for, 340
 —, Primary, 337
 —, Properties of, 338, 339
 —, Secondary, 337
 —, Tertiary, 337
 —, Wash Brush for, 342
 —, Water, 339
 Coma (Glossary), xvii., 356
 Combination Effects in Photo-ceramics, 657, 658
 —, Lens, 369
 —, Negatives, 169
 —, Pictures, 158-160
 —, Printing (Glossary), xvii., 158-162
 —, Registration in, 159
 —, Treatment of Landscape Negative in, 161
 Combined Toning Bath (Glossary), xvii., 231-252
 Combining Portraits, 319
 —, Masking for, 319
 Comets, Photographing, 611
 Comic Photographs, 716
 Composite Photography (Glossary), xvii., 716
 Composition (Glossary), xvii.
 —, in Landscape Photography, 496
 Compound Concentrated Toning Bath, 247
 Concave Lens (Glossary), xvii.
 Concentrated Toning Bath, 246
 Concentric Lens (Glossary), 363
 Condenser (Glossary), xvii.
 —, Bull's Eye, 531-533
 —, for Enlarging, 303, 309
 —, Lantern, 370
 —, Microscope Stage, 531, 532
 Conical Bellows, Making, 715
 Conjugate Foci (Glossary), xvii., 360
 Constant White, 352
 Contrast (Glossary), xvii.
 —, Degree of, 92
 Controtype Negative (Glossary), xvii.
 Converging Lens (Glossary), xvii.
 Convertible Lenses (Glossary), xvii.
 Cooke Focussing Lens, 374
 —, Lens (Glossary), xvii.
 —, Portrait Lens, 365
 Cooper's Process (Glossary), xvii.
 Copals (Glossary), xvii.
 Copper (Glossary), xvii.
 —, Bromide Intensifier, 135
 —, Etching, 697
 —, Plate, Polishing, 696
 —, salts, Action of Light on, 391
 —, Sulphate (Glossary), xvii.
 Copying (Glossary), xvii., 309-319
 —, Cameras for, 39
 —, Lens, 369
 —, Method of, 316
 —, Old Faded Photographs, 316
 —, Pencil Drawings, 318
 —, Person from Group, 318, 319
 —, Prints, 717
 —, with Pinhole Camera, 293
 Corallin (see Aurin)
 Cords for Pictures, 290
 Coronagraph, 610, 611
 Coronal Appendage and Astronomical Work, 602
 Corrosive Sublimates (Glossary), xvii.
 Coudé Equatorial Telescope, 605
 Cover Glass (Glossary), xvii.
 Covering Power of Lens (Glossary), xvii., 34
 Coxin (Glossary), xvii.
 —, Solution, 128
 Cramer, Lippo, on the Molecular Strain Theory, 409
 Crayons, Working up Enlargements with, 331, 332
 Crennitz White, 352
 Cresco Fylna, 317
 Cristoid Films, Development of, 122-124
 —, Expansion of, 124
 —, Pyrocatechin Developer for, 123
 —, Sandell, 122, 123
 Crookes' Spiritariscop, 710
 —, Tube (Glossary), xvii., 706, 707
 —, Using, 708
 Crooks on the Vacuum, 707
 Cross's Bleaching-out Process, 435
 —, Three-colour Heliochromy, 423
 Cross Front (Glossary), xviii.
 Crossley Reflecting Telescope, 611
 Crystal Varnish (Glossary), xviii.
 Crystoleum Process (Glossary), xviii.
 Cupric Chloride (Glossary), xviii.
 —, Sulphate (see Copper Sulphate)
 Curie and Radio-active Substances, 709
 Curvature of Field (Glossary), xviii.
 Cut-out Mounts, 274
 —, Covering, 267, 288
 Cutting Bromide Paper, 222
 —, Enlargements, 314
 —, Films, 120
 —, Negative in Half-tone Process, 695
 —, Shape (Glossary), xviii.
 Cuttings, Silver, 674
 Cutting-glass, 276
 —, Testing, 276
 Cyanine, Chinoine, or Quinoline Blue (Glossary), xviii.
 Cyanotype Process (Glossary), xviii.
 Cyanotypes, 181
 —, Solution for, 181
 Cyclic Carbon Compounds, 463
 Cylindograph (Glossary), xviii.
 Cynnagraph, 671
- D**
- Daguerre, L. J. M., 4
 —, Cameras, 362
 Daguerre's Discoveries, 4
 Daguerrotype Process (Glossary), xviii., 5
 —, Development in, 396
 Dai Cornex Hand Camera, 598, 509
 Dallmeyer Camera, 510
 —, Naturalists' Hand Camera, 640
 —, Rapid Rectilinear Lens, 363
 —, Telephoto Lens, 369, 370, 646, 650
 —, Wide-angle Rectilinear Lens, 366
 Dallmeyer-Berghelm Portrait Lens, 365, 366
 D'Almeida's Stereoscopic Projection, 630
 Dalo Hand Camera, 503, 504
 Dausac-Chassagne Colour Photography, 438
 Dark-room (Glossary), xviii., 259-272
 —, Benches, 263, 264
 —, Bichromate Lamps, 266
 —, Candle Lamps, 265
 —, Collar as, 261
 —, Cisterns, 272
 —, Clock, 117
 —, Developing without, 16
 —, Dishes used in, 267, 268
 —, Drying Boxes, 269
 —, Electric Lamps, 266
 —, Fittings, 259-272
 —, Gas Lamps, 266
 —, Heating, 262
 —, Improvising, 260, 261
 —, Lamp Shades, 270
 —, Lamps, 264-267
 —, Light for Orthochromatic Photography, 451
 —, "Safety" of, 267
 —, Light-trap Doors, 262, 263
 —, Measures, 269, 270
 —, Oil Lamps, 265, 266
 —, Order and Cleanliness in, 272
 —, Planning, 259
 —, Portable, 259, 260
 —, Cisterns, 272
 —, Professional, 259
 —, Racks, 263, 269
 —, Scales and Weights, 270
 —, Shelves, 265, 264
 —, Storage Requisites, 271
 —, Tanks, 268
 —, Ventilation, 261
 —, Ventilators, 262
 —, Water Supply, 263
 —, Taps, 264
 —, Whirler, 272
 Dark-slide (Glossary), xviii., 12, 58
 —, American, 58
 —, Book-form, 58
 —, Care of, 29
 —, Metal, 58
 —, Using, 13, 14
 Davis Astronomical Photographs, 602
 —, Focussing Screen, 545
 Davy's Method of Printing-out, 163
 Davy, Sir Humphry, 3
 Dawson's Densitometer, 223
 Daylight Developing Machines, 120
 —, Development, 128

- Daylight Enlarger, *301
— for Portraiture, 479
- Dead Black for Woodwork, 714
- Deficient Contrast (Glossary), xviii.
- Definition (Glossary), xviii.
- De la Rue and Geissler Tubes, 706
- Demeny Chronophotographie, 665
- Densitometer (Glossary), xviii.
- , Dawson's, 225
- Density (Glossary), xviii., 398, 399
— Calculations, Table of, 417
— and Inertia, Relation between, 417, 418
— Measurements, 418
— Measuring Apparatus, *415
— —, Fixed Scale of, 415
— —, Movable Scale of, 415
- Depth of Focus (Glossary), xviii.
- Derepas Dry Mounting Process, *281
- Desk for Local Reduction, 143
- Detail (Glossary), xviii.
- Detective Camera (Glossary), xviii.
- Developers (Glossary), xviii.
—, Aduroil, 112, 113, 399
—, Advantages of Factorial Method for, 116
—, Amidol, 111, 399
—, for Bromide Papers, 111
—, Combined, Factor of, 116
—, Di-amido-resorcin-hydrochlorate, 399
—, Dianine, 399
—, for Dry Ferrotypes Plates, 118
—, Eikonogen, 111, 112, 399
—, Factors of Various, 115—116
—, Ferrotypes, 81
—, Ferrous Oxalate, 110, 397, 708
—, —, Reactions of, 397
—, —, Thio-sulphate in, 397
—, Sulphate, 396
—, Formulae, 109—115
—, Glycin, 112
—, Hydroquinone, 109, 708
—, —, Single Solution, 110
—, Imogen Sulphite, 113
—, Kachin, 113
—, Making up, 18
—, Metol, 110
—, — and Hydroquinone, 110
—, Normal (Glossary), xxix., 107
—, Organic, 454
—, Ortol, 112
—, for Over-exposed Plates, 114
—, Paramidophenol, 112
—, Payne's Hydroquinone, 708
—, Potassium Oxalate, 399
—, Pyro, 107
—, — and Ammonia, 109
—, —, —, Metol, 109
—, —, —, Soda, 109
—, Pyro-acetone, 109
—, Pyrocatechin, 112
—, Pyro-soda, 18
—, Pyrogallol or Pyrogallie Acid, 107
—, Quinol, 109, 110
—, for Radiographs, 708
—, Rapid, 109
—, Reducers in, 108
—, Rodinal, 112
—, Sandell Pyro-metol, 109
—, for Snap-shot Negatives, 111
—, standard, 107
—, Synthol, 399
—, Tri-amido-phenol, 399
—, Unal, 112
—, for Under-exposed Plates, 115
—, Using stale, 127
—, Varying, 108
—, for Wet Negatives, 118
- Developing, 15—29, 107—119
—, Agents, Patent, 113
—, Appliances and Materials for, *16
—, Automatic Rocker for, *114
—, Box, Quincey, *129
- Developing Bromide Enlargements, *314
—, Carbon Prints, 190
—, Cinematograph Films, *123
—, Collotype Plates, 680
—, without Dark Room, 16
—, Daylight, Machines for, 129
—, Dishes for, *16, *17
—, Films in Rolls, 121
—, First Lesson in, 19
—, Glass and Celluloid Measures for, 18
—, Machines, Kodak, 129
—, Method of, 113—130
—, Operation, 113, 114
—, Photo-ceramics, 654
—, in Photogravure Process, 701
—, Photo-litho Transfer, 684
—, Plate after Fixing, 129, 130
—, Power of Red Light, 390
—, —, Yellow Light, 390
—, Principles of, 15
—, Scales and Weights for, 18
—, Stereoscopic Negatives, 622
—, Trough, Tyuna, 129
—, Washing Tank and Rack for, *17
—, Woodburytypes, 702
- Development (Glossary), xviii.
—, Acid, 397
—, — and Alkaline, Difference between, 399
—, Alkaline, 398
—, Chemistry of, 396—405
—, of Cristoid Films, *122—124
—, Daylight, 128
—, Factorial (see Plate 8)
—, —, System of, 115—117
—, of Films, 119—130
—, and Fixing Combined, 130
—, Latent Image and, 396
—, Local, 117, 118
—, by Mercury Vapour, 396
—, Modifications in, 93
—, Neutral, 399
—, of Plates, 107—119
—, Process of Printing, 186—238
—, Restrainers for, 396, 397
—, Special Hints on, 130
—, Stand, 117
—, Tentative, 117
—, of Wrongly Exposed Plates, 118
- Deviation (Glossary), xviii.
- Dewar and Molecular Strain, 410
- Dextrin, or British Gum (Glossary), xviii.
- Diactinic (Glossary), xviii.
- Dialyser (Glossary), xviii.
- Diamidophenol Developer, Factor of, 116
- Di-amido-phenols, 466
- Di-amido-resorcin Hydrochlorate Developer, 399
- Dlanine (Glossary), xviii.
—, Developer, 399
- Dianol (Glossary), xviii.
- Diaphragm (see Stops)
—, for Half-tone Process, 687
—, Shutter (Glossary), xviii.
- Diaphragms, Interchangeable, *533
—, Iris (Glossary), xxv., 15, 30, 31, 533
—, Lens, 372
—, Microscope, 531, 532
- Diazotype or Pruniline Process (Glossary), xxvii.
- Di-carboxylic Acids, 459
- Dichroic Fog (Glossary), xviii.
- Dichromatic Photography, 425
- Diffraction Grating Colour Photography, *432—434
—, Photographs, Viewing, *435
—, —, Copying Positives by Projection, *434
—, —, Obtaining Photograph for, *434
—, —, Reproducing Positives, 435
- Diffused Light (Glossary), xviii.
- Diffusion of Focus (Glossary), xviii.
- Di-hydric Phenols, 464
- Diogen (Glossary), xviii.
—, Developer, Factor of, 116
- Diphenyl (Glossary), xviii.
- Dipper, Ebonite, 76
- Disc Diaphragm (see Rotating Stops)
- Disguising Camera in Bird Photography, 642
- Dish for Developing Films, *121
- Dispersion (Glossary), xix.
- Dissociation (Glossary), xix.
- Dissolving Views (Glossary), xix.
- Distance Meter (see Telemeter)
—, Scale (see Focussing Scale)
- Distilled Water (Glossary), xix.
- Distortion (Glossary), xix., 717
- Diverging Lens (Glossary), xix.
- Dividing-Back (see Repeating-back)
- Dodges in Landscape Photography, 499
- Dodging, Plate 18
- Doppler's Principle in Astronomical Photography, 608
- Dore and Stereoscopic Projection, 630
- Dot Formation in Half-tone Processes, 686, 687
- Double Photographs, 716
—, Transfer (Glossary), xix.
- Doublet (Glossary), xix.
- Dragon's Blood, 698
- Draper's Experiments, 391
- Drapery, Colouring, 344
- Drawings, Copying Pencil, 318
- Dress, Improving, in Enlargements, 350, 351
- Drop-shutter (Glossary), xix.
- Drum, Revolving, for Film, 122
- Drummond Light or Limelight (Glossary), xxv.
- Drumer's Stereoscopic Camera, *547
- Dry Collodion (Glossary), xix.; (see also Collodion)
—, —, Plates, 685
—, Collotype Plates, 685
—, Mounting, 280, 281
—, —, Derepas, 281
—, —, with Heat, 231
- Drying Marks (Glossary), xix.
—, Negatives, 126
—, Photo-litho Transfer Paper, 683, 684
- Drying-cupboard (Glossary), xix.
- Drying-oven for Collotype Plates, 679
- Drying-rack (Glossary), xix., *126
—, Wooden, 20
- Dry-plate (Glossary), xix.
- Duboscq Telephoto Lens, 646
- Ducos du Hauron's Stereoscopic Projection, 630
- Dust Spots on Negatives, 127
- Dusting in Photogravure Process, 701
- Dusting-on Process (Glossary), xix., 201—205
—, —, in Photo-ceramics, 653
—, —, Actinometer for, *203
—, —, Coating Plate, 203
—, —, Combination Pictures, 204, 205
—, —, Developing Plate, 204
—, —, Exposing Plate, 203
—, —, Fixing Image, 204
—, —, Hydrometer used in, *202
—, —, Materials for, 201
—, —, Making Transparency in, 201, 202
—, —, Powder for, 203
—, —, Sensitising Formula for, 202
—, —, Supports for, 203
- Dust-proof Binding, 291
- Dyes as Colour Sensitisers, 441

- Dyes, Colouring Prints with, 351
 —, Effects of, on Films, 388
 —, Experiments with, 388
 —, Tinting Prints with, 351
 Dynar (Glossary), xix.
- E**
- Easel for Colouring, *340
 —, —, Enlarging, *304, *305
 Eau-de-Javelle (Glossary), xix.
 —, Reducer, 140
 Ebonite (Glossary), xix.
 Eburneum Process (Glossary), xix.
 Eclipse System of Stereoscopic Projection, 631
 Eclipses, Photographing, *609, 610
 Eder on Action of Light, 406
 —, on the Ripening of Emulsions, 410
 —, —, Three-colour Work, 437
 Eder's Experiments, 398, 399
 —, Process of Reduction, 401
 Edinol Developer, Factor of, 116
 Edison Kinetoscope, 665
 Edwards and Radiography, 707, 709
 Eikonogen (Glossary), xix., 467, 468
 —, Developer, 111, 112, 399
 —, —, for Bromides, 229
 —, —, Factor of, 116
 Eikronometer (Glossary), xix.
 —, Watkins', *117
 Electric Current for Radiography, 705
 —, Lamps, Dark-room, 266
 —, Light for Portraiture, 474
 —, Lighting for Half-tone Work, *694
 Electricity and Light, Identity of, 394
 Elliott Stereoscope, *626
 Emerald Green, 352
 Emery (Glossary), xix.
 Emsz and Sub-salts, 408
 Emulsion (Glossary), xix., 462
 —, Burker's Printing-out, 175
 —, Boiling and Testing, 64
 —, Collodio-gelatine (Glossary), xvi.
 —, Collodion, 695
 —, for Collodion Dry-plates, 83
 —, Cooling, 64
 —, Dish for Cooling, 64, *65
 —, Filtering, 65—67
 —, Formula for, 60
 —, Gelatine, Coating Paper with, 177
 —, Making, Spraying in, 63
 —, Mixing, 179, 180
 —, —, Preparing Solution for, 179, 180
 —, Precipitating, 64
 —, —, with Alcohol, 65
 —, Preparing, 60—67
 —, Press, *71
 —, Removing Potassium Nitrate from, 64
 —, Ripened with Ammonia, 72
 —, Ripening, 410
 —, Sensitiveness of, 60
 —, Shredding, 64
 —, Stripping from Plates, 676
 —, Trough, *176, 177
 —, Washing, 64
 —, Water-jacket, *65, 66
 Enamel (Glossary), xix.
 —, Black, 654, 655
 —, Ceramic Photograph (Glossary), xv.
 —, Plaques, Firing, 661, 662
 Enamelled Carbons, 197, 198
 —, —, Avoiding Crapiness in, 197
 Enamelling (Glossary), xix.
 —, —, Prints, 286, 287
 Enamels, Painted, 658
 Eucastic Paste (Glossary), xix., 287
 Endemann's Process (Glossary), xix.
 Engraver's Tracing-point, *279
 Engraving, Dry, of Blocks, *699
 Enlargements, Chalk Backgrounds in, 334
 —, Cutting, 314
 —, Development of, *314
 —, and Direct Pictures, Comparing, 300
 —, Fancy Backgrounds in, 335
 —, Heightening Lights in, 335
 —, Improving Dress in, 330, 331
 —, —, Eyes in, 328, *329
 —, —, Hair in, 329, *330
 —, —, Modelling in, 328
 —, —, Mouth in, 328
 —, —, Nose in, 328
 —, Lighting for Working-up, 329
 —, Mechanical Washer for, *314
 —, Mounting, 315
 —, Painted Backgrounds for, 331
 —, Pins for, *313
 —, Position for Working-up, *329
 —, Smoothing Face in, 332
 —, Washing, *314
 —, Working-up, 327, 328
 —, —, with Crayons, 331, 332
 —, —, in Monochrome, 325—336
 —, —, by Stamping, 332
 Enlarging (Glossary), xx., *500—315
 —, Apparatus for Artificial Light, *305
 —, —, Automatic Focussing, *303
 —, —, without Bellows, *303
 —, —, Daylight, *301, *302
 —, —, Folding Bellows Fixed Focus, *302
 —, —, Lens or Objective for, 310
 —, —, Negative Carrier of, *303
 —, —, with Parabolic Reflector, 302
 —, —, Parabolic Reflectors, *302, *308
 —, —, Reflector for, 309
 —, —, Ruby Cap for, 310
 —, —, Simple Fixed Focus, *302
 —, —, Artificial Light for, 305
 —, —, by Artificial Light, 311, *312
 —, —, without Lantern, *317
 —, —, Bromide, 300
 —, —, Calculation of Conjugate Foci, 306, 307
 —, —, Choice of Negative for, 311
 —, —, without Condenser, *308
 —, —, Condenser for, *308, 309
 —, —, Diameter of Condenser for, 309
 —, —, Diffusers for, 309
 —, —, Distribution of Light for, *307
 —, —, Dodging in, 312, *313
 —, —, Easels for, *304, *305
 —, —, Exposure in, 312
 —, —, Focussing in, 311, 312
 —, —, Introducing Skies, *313, 314
 —, —, Lantern, Cantilever, *306
 —, —, Eureka, *306
 —, —, Portable Oil, *306
 —, —, with Lantern, *306
 —, —, Lens, 369
 —, —, Negative Carriers used in, *309, 310
 —, —, Negatives, *315
 —, —, by Wet Collodion Process, 318
 —, —, with Pinhole Camera, 298
 —, —, Room for, 310
 —, —, Source of Light for, 307, 308
 —, —, Sufficiency of Light for, *307
 —, —, by Stripping the Film, 317
 —, —, Table for, *305
 —, —, Vignetting in, 313
 Ensign-Vidil Film, *120
 Envelopes, Plates Enclosed in, for Radiography, 205
 Eosin (Glossary), xx.
 Equivalent Focus (Glossary), xx., 360
 Erasing and Scraping Prints, 333
 Ernemann Camera, 509
 Erythrosin (Glossary), xx., 72
 Etch (Glossary), xx.
 —, —, for Collotype Plates, 630, 631
 —, —, Finishing, 693, 699
 —, —, Fine, 693, 699
 Etching (Glossary), xx.
 —, —, Copper or Brass, 697
 —, —, Ink, American, 693
 —, —, in Photogravure Process, 701
 —, —, Trough, *697
 —, —, Zinc Plates, *697
 Ether (Glossary), xx.
 Ethyl Alcohol, 455—457
 Ethylic Oxide (see Ether)
 Eureka Enlarging Lantern, *306
 Euryscope (Glossary), xx.
 Evans and Friese-Greene Cinematograph, 664
 Everest Shutter (Glossary), xx., 55, *56
 Excessive Contrast (Glossary), xx.
 Exhausting Vacuum Tubes, 707
 Exhibiting Animated Photographs, 671, 672
 Expansion, Reduction by, 143
 Exposing Collotype Plates, 680
 Exposure (Glossary), xx.
 —, —, Atmospheric Influences on, 87
 —, —, for Bromide Printing, 225, 224
 —, —, Instantaneous Photography, 105
 —, —, Photo-ceramics, 654
 —, —, Portraiture in Room, 99
 —, —, Stereoscopes, 619, 620
 —, —, Woodburytypes, 702
 —, —, Changes occurring during, 407
 —, —, in Enlarging, 312
 —, —, Estimating, 96
 —, —, Experimental, 416
 —, —, Factors affecting, 85
 —, —, Fallacies regarding, 85
 —, —, First Lesson in, 13
 —, —, Indicator (Glossary), xx.
 —, —, Influence of Distance on, 89
 —, —, Interpretation of Subject, 95
 —, —, Latitude of (Glossary), xxvi.
 —, —, Meter (Glossary), xx., *93—105
 —, —, Bee, 102
 —, —, Home-made, *103
 —, —, Ilford, *100
 —, —, Infallible, 103
 —, —, Making, *103, *104
 —, —, Testing with, 101
 —, —, Using, 100, 102, 104
 —, —, Watkins' for Indoor Work, 102
 —, —, Standard, 100
 —, —, Wynne's Infallible, *103
 —, —, Method of, 85
 —, —, Metronome for Timing, *224
 —, —, Note-book, 96
 —, —, Periods of, *416
 —, —, of Plates, 84—106
 —, —, —, in Photomicrography, 518, 519
 —, —, Proportionate Speeds for, 98
 —, —, Rule for, 97
 —, —, Simplest Guide to, 97
 —, —, Table, 95
 —, —, Timing Devices, *224, 225
 —, —, Unit of, 415
 —, —, Using Stops in, 66
 —, —, Varied Effects of Different Subjects, 95
 Extension (Glossary), xx.
 Eye, Accommodation of (Glossary), ix., 612
 —, —, Adjustment, Axial, 613
 Eyelashes, Colouring, 343
 Eyes, Colouring, 343
 —, —, Improving, in Enlargements, *328, 329
 —, —, In Retouching, 150

F

- Fabric, Golden (Glossary), xx.
 Fabrieus' Discovery in Actinism, 5
 Face, Colouring, 342
 —, Smoothing, in Enlargements, 332
 Factorial Development (Glossary), xx., 115—116
 Factories, Photographing, 560
 Factory, Photographic Paper, *213—216
 Falling Front (Glossary), xx.
 Falloroll Hand Camera, 502, 503
 Farmer's Daylight Development, 123
 — Ferricyanide Reducer, 139
 — Intensification Process, 131
 — Reducer, 402
 Fatty Carbon Compounds, 454, 455
 Feertype (Glossary), xx.
 Ferric Ammonium Citrate (Glossary), xx.
 — Oxalate (Glossary), xx.
 — Chloride (Glossary), xx.
 — Reducer, 139, 140, 401
 —, Sensibility of to Red Rays, 392
 — Oxalate (Glossary), xx., 459
 — in Platinotype Process, 207
 —, Preparing, 207, 208
 — Salts, Action of Light on, 392
 Ferricyanide Reducer, 139, 142, 402
 Ferro-gallic Process (see Colar's Process)
 Ferro-prussiate Process (Glossary), xx., 180, 181
 Ferrottype (Glossary), xx., 30
 — Camera, 80
 —, Making, 48, 49
 —, Plate Wires for, 49
 — Plates, 118
 —, American Dry, 119
 —, Developer for, 81, 118
 —, Dry, Developer for, 119
 — Process, 80
 —, Dark Tent for, *80
 —, Developing Plate, 82
 —, Exposing Plate, 82
 —, Fixing Plate, 82
 —, Home-made Collodion for, 81
 —, Requisites for, 81
 —, Sensitising Film, 82
 —, Silver Bath for, 81
 Ferrous Oxalate (Glossary), xx.
 — Developer, 110, 397, 708
 — for Bromide Prints, 229
 —, Clearing Bath for, 111
 —, Reactions of, 397
 —, Thio sulphate in, 397
 — Intensifier, 403
 — Sulphate (Glossary), xxi.
 — Developer, 396
 Figure Study, Plate, 23
 Figures in Landscape Photography, 499
 Film (Glossary), xxi.
 —, Effect of Dyes on Sensitive, 368
 — Holder, *19
 — Photography (Glossary), xxi.
 Film-packs, 58
 Films, 60—84, 119, 120
 —, Animatograph, Care of, 673
 —, Colouring, 673
 —, Joining, 673
 —, Cinematograph, Developing, 122
 —, Cristoid, Development of, *122—124
 —, Development of, 119—130
 —, Dish for Developing, *121
 —, Ensign Vidil, *120
 Films, Frame for Washing, 121
 —, Method of Cutting, 120
 —, Premo, 58
 —, Revolving Drum for, *122
 —, Right Side of, 115
 —, Sandell Cristoid, 122, 123
 —, Special Appliances for Developing, *121, 122
 —, Use of, 16
 Filter for Sensitiser used in Collo-type Process, 679
 —, Light, 446
 Filtering Residues, *674
 Filtration, Upward, *168
 Fine Etch, 699
 Finishing Etch, 698, 699
 — Enamel Plaques, 661, 662
 — Photo-ceramics, 656, 658, 660—662
 Fischer, B., 3
 — on the Sub-salt Theory, 407
 Fish, Aquarium for Photographing, 645
 — Glue Process (Glossary), xxi.
 — Photographing, 643, 644
 —, Washing, before Photographing, 643, 644
 Fisher and Stereo-Anima-Photography, 632
 Fixed Focus Camera (Glossary), xxi.
 Fixing (Glossary), xxi., 124, 125
 — Baths for Prints, 253, 254
 —, Treatment of Old, 676
 —, Combined Development and, 150
 —, Developing Plate after, 129, 150
 —, Large Dish for, 17
 —, Loss of Tone in, 258
 —, Prints, Method of, 255
 —, Solution, 21
 — for Plates, 19
 — used as Reducer, 142, 143
 — without Toning, 250
 — and Toning Bath Combined, 251
 Flake White, 352
 Flap Shutter, Making, *714
 Flare Spot in Lens (Glossary), 372
 —, Testing for, 35
 Flash-lamp (Glossary), xxi.
 — for Portraiture, *476
 Flashlight Installation for Portraiture, 477
 — for Interior Photography, 558
 — Photography (Glossary), xxi. (see also Plate 15, facing p. 193)
 — Portraiture, 477, 478
 Flatness (Glossary), xxi.
 — of Field (Glossary), xxi.
 Fletcher, Russell and Co.'s Gas Furnaces, 658—661
 Fletcher's Injector Furnace for Residues, 676
 Flexible or Temporary Support (Glossary), xxi.
 Floating (Glossary), xxi.
 Floral Subjects for Stereoscopy, 622
 Florentine Frames, 291
 Florent's Colour Photography, 420
 Flower Photographs, 638, 639
 Flower Studies (see Plates 38, 40)
 — in Orthochromatic Photography, 450
 Fluid Measure, 718
 Fluorescent Screens, 704, 705
 —, Making, 711
 — X-ray Tube, 707
 Fluorescin or Resorein-phthalein (Glossary), xxi.
 Fluorotype (Glossary) xxi.
 Focal Changes, in Stereoscopic Photography, 612
 — Length of Lens (see Equivalent Focus)
 Focal-plane Shutter (Glossary), xxi.
 Focal-plane Shutter for Animal Photography, 640, 641
 Focul (Glossary), xxi.
 —, Conjugate (see Conjugate Focul)
 —, Variable of Telephoto Lens, 648, 649
 Focimeter (Glossary), xxi.
 Focometer (Glossary), xxi.
 Focoplane Camera, 510
 Focus (Glossary), xxi.
 —, Ascertaining, 34, 360
 —, Back, 360
 —, Depth of, 361
 —, Equivalent, 34, 360
 —, Tube used in Radiography, 706
 Focussing Cloth (Glossary), xxi.
 — in Enlarging, 311, 312
 — Explained, 12
 — Glass (see Focussing Magnifier)
 — Hand Camera, Graduating Scale of, 373
 — Jacket (Glossary), xxi.
 — in Landscape Photography, 494
 — Lens (Glossary), xxi.
 — Magnifier (Glossary), xxi.
 — for Landscape Photography, *485
 — Scale (Glossary), xxi.
 — Screen (Glossary), xxi., 12
 — for Monumental Work, *588
 Fog (Glossary), xxi.
 — Chemical (Glossary), xv., 94
 —, Colour, Abney's Method of Removing, 140
 —, Dichroic (Glossary), xviii.
 —, Effects of, 94
 —, Green (Glossary), xxiii., 402
 —, Light, 94
 —, Red (Glossary), xxxiii.
 —, Utilising, 94
 —, Dangers of, 95
 Fogged Negatives, Reduction of, 143, 144
 Folding Pocket Cyko Hand Camera, *503
 Forcing (Glossary), xxi.
 Foreground Proportions in Landscape Photography, *495, 496
 Formaldehyde, 357
 Formalin (Glossary), xxi., 457
 Formate of Soda Toning Bath, 247
 Formic Acid, 459
 Formosulphite (Glossary), xxi.
 Foxlee, Mr. E. W., on Bichromate Disease, 194
 Fox-Talbot, Henry, Work of, 5
 — and Photogravure, 701
 Frame making, *290—293
 —, Cutting Mouldings, 290
 —, Gluing, *290, 291
 —, Mitre Trimming, *290
 —, Mitring Corner Ornaments, 291
 —, Nailing, 290, 291
 Frame-mouldings, 288 (see also Plate 21, facing p. 289)
 Frames, Cords and Rings for, *290
 —, Fixing Pictures in, 289, 290
 —, Florentine, 291
 Framing: Dust-proof Binding, 291
 —, Glass for, 289
 —, Photographs, *288—293
 Fraunhofer Lines, 570, 571
 Frena Hand Camera, *503
 French Vermilion, 352
 Friess-Greene and Evans Cinematograph, 664
 Frilling (Glossary), xxii., 63
 Front (Glossary), xxii.
 Full Aperture (Glossary), xxii.
 Fuming (Glossary), xxii.
 — Albumen Paper, *174
 — Sensitised Paper, 174

Furfural, 459
Furnaces for Photo-ceramics, 656—661
Furniture, Studio, 472

G

Gallie Acid (Glossary), xxii.
Galloping Horse, Speed of, 105
Gamboge (Glossary), xxii.
Gas Furnaces for Photo-ceramics, 658—661
— Lamps, Dark-room, 266
Gaslight Paper (Glossary), xxii., 255
— Developing, 235
— Fixing, 235
— Tones of, 235
Gaumont's Chrono Camera, 665
— Exposure in, 665, 666
— Taking Picture with, 666
— La Grille, 673
— Oxygenator, 479
Gauss Points (Nodal) (Glossary), xxviii.
Gelsler Tubes, 706
Gelatine (Glossary), xxii., 462
— Bichromated (Glossary), xiii.
— Dissolving, 62
— Emulsion (Glossary), xxii.
— Coating Paper with, 177
— Preparing, 175
— Hardening, 462, 463
— Introduction of, 6
— Mixing, 62
— Mounting with, 275
— Relief from Dry Plates, 705
— Testing, 175, 176
Gelatino-bromide (Glossary), xxii.
— Lantern Slides, 322, 325
Gelatino-chloride (Glossary), xxii.
— Paper, Action of Light on, 404
— Process, 167, 175
Germ-eil-Bonnaud's Powder Process, 457
Ghost Photographs, 717
Gifford's Monochromatic Screen, 421
Glacial Acetic Acid, 458
Glass (Glossary), xxii.
— Discoloration of, 35
— for Framing, 289
— Jena (Glossary), xxv.
— Plates, 177, 178
— Introduction of, 6
Glass-painter's Furnace, 661
Glazed Surface (Glossary), xxii.
Glazing Prints, 286
Glazing Studio, 470
Globe Lens (Glossary), xxii.
Glossy Papers, 177
Glucose, or Grape Sugar (Glossary), xxii.
Glycerine (Glossary), xxii.
Glycin, or Parahydroxyglycine (Glossary), xxii.
— Developer, 112
— Factor of, 116
Goddard's Experiments, 392
Goetz Double Anastigmat Lens, 365, 367, 640
— Reversing Prism, 695
— Stereo Binocular, 596
— Telephoto Lens, 650
Goetz-Anschütz Camera, 509
Gold (Glossary), xxii.
— Chloride, or Gold Trichloride (Glossary), xxii.
— Combined Toning Bath, 252
— Compounds, Action of Light on, 392, 393
— Hyposulphite (Glossary), xxiii.
— and Iridium Bath for Photo-ceramics, 657

Gold and Platinum Bath for Photo-ceramics, 657
— Slips for Mouldings, 289
— Toning (Glossary), xxiii., 239—258, 405
— Bath, Dilution of, 245
— Preparing, 245—247
— Strength of, for Different Tones, 247
— Temperature of, 245
— Varying Strength of, 245
— of Collodio-chloride Papers, 243
— P.O.P., 243
Gold-uranium Toning, 256
Goupiil Process (Glossary), xxiii.
Gowenlock and Barnard's Kromaz, 427, 428
Graining in Photogravure Process, 701
Grape Sugar (see Glucose)
Graphoscope, 650
Grating, Concave, 574, 579
— Reflection, 577, 578
— Transmission, 576, 579
Green Fog (see Dichroic Fog)
Greenhouse as Studio, 486, 487
Gregory's Telescope, 596
Grimaud's Glass, 562
Grossman and Ohm's Collotype Process, 678
Ground Glass (Glossary), xxiii.
Group Arrangement in Portraiture, 482
— Lens, 368
Grubb's Stereoscope, 628
Grün Liquid Lens (Glossary), xxiii., 374, 375
Gum Arabic, or Gum Acacia (Glossary), xxiii.
— Bichromate Process (Glossary), xxiii., 199, 200
— Coating Paper for, 199, 200
— Development in, 200
— Marion's, 199
— Dammur (Glossary), xxiii.
— Mastic (Glossary), xxvii.
— Solution for Colours, 340
Gun, Marey's Photographic, 664
Gun-cotton (Glossary), xxiii., 461
Guntz on Sub-salts, 408
Gutta-percha (Glossary), xxiii.
— Mountant, 275
Guyot's Camera Obscura, 2

H

H. and D. (see Hurter and Driffield)
Haddon's Reducer, 142
Hair, Colouring, 342, 474
— Improving, in Enlargements, 329, 350
Halation (Glossary), xxiii.
— in Interior Photography, 555
Half-plate (Glossary), xxiii.
Half-tone (Glossary), xxiii.
— Process, 677, 685—701
— Albumen, 697, 693
— American Etching Ink for, 698
— Arc Lamp for, 694
— Bitumen, 698
— Bromo-iodising Plates, 695
— Burning-in of Plates, 696
— Camera, 679, 699
— Base of, 890
— Copy Board for, 890
— Goetz Reversing Prism for, 693
— Lens of, 692, 693
— Mirror of, 693
— Prism for, 693

Half-tone Process Camera, Swing Base for, 690
— Carbon Arc Lamp for, 694
— "Cutting" Negative in, 695
— Determining Diaphragm, 687
— Developer, 695
— Dot Formation in, 626, 687
— Dry Engraving, 699
— Electric Lighting for, 694
— Etching Copper and Brass, 697
— Zinc Plates, 697
— Etching trough, 697
— Exposure for, 694
— Fine Etch, 698
— Finishing Etch, 698
— Influence of Stop on Dots, 687
— Intensification, 695
— Linley Camera for, 690
— Metzograph Screen for, 686
— Mounting, 700
— Negative Making, 694
— Polishing Copper Plate, 696
— Principle of, 685
— Printing on Metal, 695
— Proving, 700
— Routing, 700
— Ruled Screen for, 686
— Screen Distance for, 688
— and Plate Holder for, 688, 689
— Sensitising Metal, 696
— Size of Dots in, 687
— Studio for, 638, 689
— Trimming, 699
— Watson's Camera for, 689
— Wet Collodion for, 694, 695
— Wheeler's Metzograph Screen for, 686
— Whirler used in, 696
— Trichromatic Colour Photography, 456, 437
Hall's Needles for Pinhole Work, 295
Halogen (Glossary), xxiii., 390
— Absorbents, Necessity of, 390
— Absorption, 400
— Bromine, 390
— Chlorine, 390
— Iodine, 390
— Properties of, 390
Haloid (Glossary), xxiii.
Hancock and Sons, Photo-ceramic specialists, 665
Hand Camera and Landscape Photography, 500, 501
— Cameras (see Cameras)
Hardness (Glossary), xxiii.
Hauerrisser and Intensification, 402
Hauron's Colour Process, 423, 453
Head-rest (Glossary), xxiii., 491
Head-screens for Portraiture, 473
Heating Dark-room, 282
— Studio, 471
Heliar (Glossary), xxiii.
Heliochrome (Glossary), xxiii.
Heliochrome, Cros's, 423
— Hauron's, 425
Heliograph, Spectrum, 607
Heliography, 4
Heliostat, 513, 514, 584, 585
Heliotype (Glossary), xxiii.
Heliot's Experiments on Gold Chloride, 392
Helmholtz's Theory of Colour Vision, 424
Henderson's Fog Removal Process, 402
Hennel and Carbon Compounds, 454
Herschell's Discoveries, 5
— Experiments, 391—393

Herschel's Astronomical Photography, 611
 --- Chryso-type Process, 206
 --- Colour Photography, 420
 --- Telescope, *596
 Hertz and Radiography, 704
 Hewitt Mercury Vapour Lamp, 479
 High Lights (Glossary), xxiii.
 Hinks' Oil Lamp Burners, 517
 Hodgkinson on Oxy-chloride Theory, 408
 Hofmann Colour Photography, 438
 Hog Hair Brushes for Painting, *348, *349
 Holmes Stereoscope, 627
 Holostigmat (Glossary), xxiii.
 Holostigmatic Lens, 640
 Holt's Vignetter, 699
 Holtz Machine for Radiography, 706
 Homocentric (Glossary), xxiii.
 Hood Shutter (Glossary), xxiii.
 Hübl's Ferricyanide of Iron Intensifier, 210
 --- Platinum Intensifier, 210
 --- Three-colour Work, 457
 Huerek's Camera for Photomicrography, *540
 Huggins on Astronomical Photography, 605, 611
 Hughes' Bio-dictoroscope, 671
 Hunt's Experiments, 391, 392
 --- Colour Photography, 420
 Hurter and Driffield System (Glossary), xxiii., 413
 --- Actinograph, 106, 419
 Husnik's Collotype Process, 678
 Huygenian Eye-pieces, *528
 Hydramine (Glossary), xxiii.
 Hydrobromic Acid (Glossary), xxiii.
 Hydrochinone (see Hydroquinone)
 Hydrochloric Acid (Glossary), xxiii.
 Hydrofluoric Acid or Hydrogen Fluoride (Glossary), xxiii.
 Hydrogen (Glossary), xxiv.
 --- Dioxide (Glossary), xxiv.
 --- Fluoride (Glossary), xxiii.
 --- Lines in Astronomical Photography, 603
 --- Peroxide (Glossary), xxiv.
 --- Sodium Carbonate (Glossary), xxxv.
 --- Sulphate or Sulphuric Acid (Glossary), xxxvii.
 Hydrokinone (see Hydroquinone)
 Hydroquinone (Glossary), xxiv., 465
 --- Developer, 109, 703
 --- for Bromides, 223
 ---, Factor of, 116
 ---, Single Solution, 110
 --- and Metal Developer, 110
 Hydroxylamine (Glossary), xxiv.
 --- Hydrochloride (Glossary), xxiv.
 Hydroxyl Carbon Compound, 455
 Hydroxy-tri-carboxylic Acids, 469
 Hypergon (Glossary), xxiv.
 Hypo- or Sodium Thiosulphate (Glossary), xxvi.
 --- Eliminator (Glossary), xxiv.
 ---, Preparing, 253
 --- Stains, Treatment of, 257

I

Iceland Moss (Glossary), xxiv.
 Icometer (Glossary), xxiv.
 Ifford Camera, 509
 --- Empress Plate, 98
 --- Exposure Meter, *100
 --- Monarch Plates, 99
 --- Ordinary Plates, 99
 --- Plates, Speeds of, 419
 --- Special Rapid Plates, 98, 99
 Illuminant for Animated Photography, 672, 673

Image (Glossary), xxiv.
 Imogen Sulphite (Glossary), xxiv.
 --- Developer, 113
 ---, Factor of, 116
 Imperial Flashlight Plates, 99
 --- Special Rapid Plates, 99
 Incandescent Gaslight for Portraiture, 475
 --- Photomicrography, 517, 518
 Index of Refraction (Glossary), xxiv.
 Indicators, Print, *183, 184
 Indian Ink (Glossary), xxiv.
 --- Red, 352
 India-rubber (Glossary), xxiv.
 --- Mountant, 275
 --- Solution (Glossary), xxiv.
 India-tint Mounts, 275
 Indoor Work, Watkins' Exposure Meter for, 102
 Infinitly (Glossary), xxiv.
 Infra Red Rays (Glossary), xxiv.
 Injector Furnace for Residues, Fletcher's, 676
 Ink, American Etching, 698
 --- Process (Glossary), xxiv.
 Inking-up Collotype Plates, 682
 --- in Photo-lithography, 684
 Insects, Photographing, 644, 645
 Instantaneous Photography (Glossary), xxiv.
 --- Exposure in, 105
 --- Shutter (Glossary), xxv.
 --- Tele-photography, 651, 652
 Intensification (Glossary), xxv.
 --- with Ammonia, 402
 --- without Blackening, 135
 --- of Carbon Prints, 198
 ---, Chapman Jones Process of, 403
 ---, Chemical, 131, 132
 --- Changes caused by, 132
 --- of Dry Collodion Plates, 137
 ---, Farmer's Process of, 151
 --- with Ferrons Oxalate, 405
 --- of Fogged Negatives, 137
 ---, Hauberriesser and, 402
 --- by Heat, 132
 ---, Lockett's Method of, 136
 --- with Mercury, 132
 --- of Negatives, 131-137, 402
 ---, Meaning of, 131
 --- with Permanganate, 131
 ---, Physical, 131, 132
 ---, Regulating Degree of, 135
 --- with Silver Bromide and Ferrous Oxalate, 131
 --- Pyro, 131
 --- Sodium Sulphite, 402
 --- Spirit, 132
 --- Superposition, 136
 ---, Valenta and, 405
 ---, Various Methods of, 136
 --- of Wet Collodion Plates, 136
 --- in Wet Plate Process, 695
 Intensifier, Copper Bromide, 155
 ---, Lead, 403
 ---, Ferrieyanide, 135
 ---, Mercuric Iodide, 135
 ---, Monckhoven's, 134
 ---, Uranium, 134, 135, 405
 ---, Wollington's Silver, 135, 136
 Intensity Ratio (Glossary), xxv., 86
 Interference Image (Glossary), xxv., 421
 Interior, Badly Illuminated, Photographing, 101
 --- Photography, 555-561
 --- Dark-room Precautions, 559, 560
 --- Development, 556, 557
 --- Domestic Interiors, 560
 --- Exposure for, 556
 --- Figures in, 559
 --- Flashlight for, 558
 --- Focussing, 559
 --- Halation in, 555

Interior Photography: Lighting, 559
 --- Meter for, 556
 --- Plates for, *555
 --- Rapid Plates for, 557
 --- Stained Glass, 557, 558
 --- Tripod Stand for, 53
 --- Use of Exposure Meter in, 101
 --- Window Treatment in, 558
 --- Views (see Plates 4, 22, 37)
 Invincible Camera, 510
 Iodine (Glossary), xxv.
 --- Testing, for Exposure, 101
 ---, Daguerre's Experiments with, 5
 --- Halogen, 390
 Iodiser (Glossary), xxv.
 Iridescent Markings (Glossary), xxv.
 Iridium and Gold Bath for Photo-ceramics, 657
 Iris Diaphragm (Glossary), xxv., 15, 30, 31
 --- Vignetter, *153
 Iron (Glossary), xxv.
 --- Compounds (see Ferric)
 --- Perchloride (Ferric Chloride) (Glossary), xx.
 --- Process for Photo-ceramics, 656
 --- Salts of, 295
 --- in Platinum Printing, 392
 Isinglass (Glossary), xxv.
 Isochromatic Plates (Glossary), xxv., 87
 --- Screen (Glossary), xxv.
 Isomeric Carbon Compounds, 455
 --- Di-substitution; Carbon Compounds, 464, 465
 Ives' Colour Photography, 425-428
 --- Development, 425
 --- Exposure, 425
 --- Recording Colours, 425-427
 --- Kromskop, 425, *426, 427
 --- Process (Glossary), xxv.
 Ivorytype (Glossary), xxv.
 Izenthal's Experiments in Radiography, 707

J

Jackson's Focus Tube, *706, 707
 Janssen on Astronomical Photography, 605
 Janssen's Photographic Revolver, 664
 Jaune Brillant, 352
 Jena Glass (Glossary), xxv., 762
 Jenkins' Printing Arrangement for making Positive Films, 667
 Johnson's Actinometer, *189
 Joly Colour Photography (Glossary), xxv., 428, 429
 Jones, Chapman, on Intensification, 405
 ---, the Molecular Strain Theory, 409
 ---, Opacity Meter, *418, 419
 Junior Camera, Prestwich, 671
 Juniper Resin or Sandarac (Glossary), xxxiv.

K

Kachin (Glossary), xxv.
 --- Developer, 113
 ---, Factor of, 116
 Kallitype (Glossary), xxv.
 Kammatograph (Glossary), xxv., 671
 Kaolin (Glossary), xxv.
 Katatype (Glossary), xxv.
 Kearton Brothers and Animal Photography, 641
 Kennett Gelatine Plate, 6
 Kermetter Gelatine Plate, 6

- Ketones: Carbon Compounds, 469
 Kinetoscope (Glossary), xxv.
 —, Edison, 17
 Kings' Yellow, 352
 Kinocyanine (Glossary), xxv.
 Kinora, Lumière's, 673
 Kirby's Needles for Pinhole Work, 296
 Kite Photography (Glossary), xxv.
 Klic's Photogravure Process, 701
 Kodak Cameras, 503-504
 — Developing Machine, 129
 —, Panoramic, 504
 Koenig's Pinachromy, 457
 Kromaz, Barnard and Gowenlock's, 427, 428
 Kromskop for Colour Photography, 425-427
- L
- Labarraque's Reducer, 140
 Lac or Shellac (Glossary), xxxiv.
 Lamp, Carbon Arc, 694
 —, Dark-room, 264-267
 —, Magnesium Ribbon Pocket, 320
 —, Sol Spirit, 324
 —, Triangular, 501
 Lancaster Filmograph Camera, 510
 Landscape Camera, Bags for, 489
 — Lens, (Glossary), xxv., xxvi.
 —, Open (Glossary), xxix.
 —, Orthochromatic Plates for, 449, 450
 —, Photography, 488-511
 —, Apparatus for, 489, 490
 —, Arrangement of Work, 495
 —, Atmospheric Perspective in, 498
 —, Balance in, 496
 —, Chiaroscuro and, 497
 —, Clouds in, 498
 —, Composition in, 496
 —, Diagonal Composition in, 497
 —, Dodges in, 499
 —, Figures in, 499
 —, Focussing in, 494
 —, Magnifier for, 495
 —, Foreground, 495, 496
 —, Proportions, 495
 —, Hand Camera and, 500
 —, Lens for, 494
 —, Light for, 490, 491
 —, Monochrome View Meter for, 491, 492
 —, Monotony avoided in, 497
 —, Moonlight Effects in, 498
 —, Mountains in, 510
 —, Negative Development in, 510, 511
 —, Perspective in, 498
 —, Plate Changing in, 499
 —, Plates for, 495
 —, Point of View in, 493
 —, Selection of Work, 495
 —, Sky Foregrounds, 495
 —, Sunset Effects in, 498
 —, Tape Measure View Meter for, 491
 —, Time for, 490
 —, Triangular Composition in, 497
 —, View Finders for, 492
 —, Meters for, 491
 —, Winter Work in, 510
 Langley Spectrophotography, 566
 Lantern Condensers, 370
 — Lenses, 370
 —, Plates (Glossary), xxvi., 118
 —, Projection, Stereoscopic, 330
 —, Slide (Glossary), xxvi., 319-324
 —, Binding, 321
 —, Carbon Process, 197
 —, Lantern Slide Clamp, 321
 —, Clouds in, 323
 —, Coloured, 323, 324
 —, Colouring, 349-351
 —, Density of, 323
 —, Diagrammatic, 323
 —, Finishing, 351
 —, Holder, 321
 —, Identifying Correct Side of, 321
 —, Making by Contact, 319
 —, Gelatino Chloride Process, 322, 323
 —, Reduction, 322
 —, Masks, 320, 321
 —, Painting, with Brush, 350, 351
 —, Finger Tip, 350
 —, Printing Frame, 320
 —, Spot Binding Strips for, 321
 —, Titling, 322
 —, Toned, 323, 324
 —, Unified Blinder for, 322
 Lanternoscope (Glossary), xxvi.
 Latent Image (Glossary), xxvi.
 — and Development, 396
 —, Elimination and Restoration of, 391
 —, Moser's Experiments with, 410
 —, Relapse and Destruction of, 399, 400
 —, Theory of, 406-411
 —, Waterhouse on, 410
 Latitude of Exposure (Glossary), xxvi.
 Lavender, Oil of (Glossary), xxvi.
 Lea, Carey, Schlippe's Salt Introduced by, 137
 —, "Photo Salts," 408, 420
 Lead (Glossary), xxvi.
 — Acetate (Glossary), xxvi.
 —, Ferricyanide Intensifier, 135
 —, Intensifier, 405
 —, Nitrate (Glossary), xxvi.
 —, Toning (Glossary), xxvi., 405
 Le Gray, 6
 Leintype (Glossary), xxvi.
 Leitz's Microscope, 523
 Lemon Yellow, 352
 Lenard and Radiography, 704
 Lens (Glossary), xxvi.
 —, Achromatic (Glossary), ix.
 —, Adapter (Glossary), ix.
 —, Adjusting Glasses for, 386
 —, Adon Telephoto, 369, 370
 —, Air Bubbles on, 35
 —, Aids Stigmatic, 374
 —, Anastigmatic (Glossary), xii., 306, 307, 363
 —, Symmetrical, 367
 —, Unsymmetrical, 367
 —, Angle of View of, 371
 —, for Animal Photography, 640
 —, Aperture of (Glossary), xii., 373
 —, Aplanatic (Glossary), xii., 363
 —, Apochromatic (Glossary), xii., for Architectural Photography, 553, 554
 —, Ascertaining Focus of, 34
 —, Astigmatism of (Glossary), xii., 356, 357
 —, Back Focus of (Glossary), xiii., 360
 —, Babinet Porta's, 362
 —, Beck Biplanar, 366
 —, Steinheil Orthostigmat, 367
 —, Berghelm (Glossary), xiii.
 —, Biconcave (Glossary), xiii.
 —, Biconvex (Glossary), xiii.
 —, Biplanar Group, 368
 —, Brasswork, 382
 —, Accuracy of, 382, 383
 —, Engraving, 384
 —, Finishing, 383
 —, Lens Brasswork, Lacquering, 383, 384
 —, Screw Threading of, 384
 —, Calculating Conjugate Foci of, 360, 361
 —, Camera for Testing, 386
 —, Care of, 30, 387
 —, Centring, 381
 —, of Glasses in, 371
 —, Chemical Focus of (Glossary), xv., 354
 —, Chevalier's, 362
 —, Choice of, 27, 33, 373
 —, Chromatic Aberration of (Glossary), xvi., 355
 —, Cinematograph, 370
 —, Classification of, 363-367
 —, Coma of, 356
 —, Combination, 369
 —, Concave (Glossary), xvii.
 —, Concentric (Glossary), xvii., 363
 —, Conjugate Foci of (Glossary), xvii., 360, 361
 —, Contact Gauge for, 380, 381
 —, Converging (Glossary), xvii.
 —, Cooke (Glossary), xvii.
 —, Focussing, 374
 —, Portrait, 365
 —, Copying, 369
 —, Covering Power of (Glossary), xvii., 28
 —, Curvature of Field in (Glossary), xviii., 357
 —, Daguerre, 362
 —, Dallmeyer Telephoto, 369, 370
 —, Wide-angle Rectilinear, 366
 —, Dallmeyer-Bergheim Portrait, 365, 366
 —, Defined, 11
 —, Depth of Focus in, 361, 362
 —, Diaphragms, 372
 —, Distortion of (Glossary), xix., 358
 —, Diverging (Glossary), xix.
 —, Double Meniscus, 364
 —, Doublet (Glossary), xix., 32
 —, Edging, 381
 —, Enlarging, 369
 —, Equivalent Focus of, 360
 —, Evolution of, 362
 —, Finding Effective Aperture of, 373
 —, Flare Spot in (Glossary), xxi., 372
 —, Flatness of Field in (Glossary), xxi.
 —, Focal Length of, 360, 378
 —, Foci of (Glossary), xxi.
 —, Focus of (Glossary), xxi.
 —, Focussing (Glossary), xxi.
 —, Scale, Graduating, 373
 —, Full Aperture of (Glossary) xvii.
 —, Gauss Points of (Glossary) xviii.
 —, Glass, 376
 —, Air-bubbles in, 377
 —, Annealing, 377
 —, Cooling, 377
 —, Glasses, Tramway Camera for Adjusting, 386
 —, Globe (Glossary), xxii.
 —, Goerz Double Anastigmat, 365, 367, 400
 —, Group, 368
 —, Grimm Liquid (Glossary) xviii., 374, 375
 —, Hellar (Glossary), xviii.
 —, Holostigmat (Glossary), xxii.
 —, Holostigmatic, 640
 —, Improvements in Modern, 34
 —, Inspection of, 381
 —, Jena Glass for, 362, 363
 —, Landscape (Glossary), xxv., xxvi., 494
 —, Lantern, 370

- Lenses, Long-focus (Glossary), xxvi.
 —, Low-power Telephoto, 640
 —, Manufacture, 375, 376
 —, Difficulties in, 376
 —, Exactness in, 375, 376
 —, Measuring, 379, 380
 —, Meniscus (Glossary), xxvii.
 —, Glasses for, 362
 —, Middle-angle (Glossary), xxviii.
 —, Mount (Glossary), xxviii.
 —, Narrow-angle (Glossary), xxviii., 35
 —, Negative (Glossary), xxviii., 648
 —, Nodal Points of (Glossary), xxviii.
 —, Non-achromatic, 355, 356
 —, Objective (Glossary), xxix.
 —, Optical Centre of (Glossary), xxix., 358-360
 —, Orthoscopic, 374
 —, Orthostigmat (Glossary), xxix., 367
 —, Universal, 367
 —, Parting Cemented, 36
 —, Perfect Definition in, 387
 —, Periscope (Glossary), xxx.
 —, Periscopic, 365
 —, Petzval (Glossary), xxx., 32
 —, Introduction of, 362
 —, Portrait, 365
 —, Photographic Definition of, 361, 362
 —, Planar (Glossary), xxxi.
 —, Planiscope (Glossary), xxxi.
 —, Platystigmat (Glossary), xxxi.
 —, Polishing, 380
 —, Portrait (Glossary), xxxi., 32, 365
 —, Positive (Glossary), xxxi., 648
 —, Preservation of, 387
 —, Principal Focus of, 360
 —, Principle of, 30, 31
 —, of Process Camera for Half-tone Work, 692, 695
 —, Rapid Rectilinear, 32
 —, Rectilinear (Glossary), 33, 363, 366
 —, Symmetrical (Glossary), xxxiii., 32
 —, Rapidity of (Glossary), xxxiii., 33, 373
 —, Rectigraph (Glossary), xxxiii.
 —, Rectilinear (Glossary), xxxiii., 28
 —, Relation of Density to Curvature in, 377, 368
 —, Ross', 362
 —, "Roughing," 378, 379
 —, Tools for, 379
 —, Rudolph's, 363
 —, Scratches on, 35
 —, Selecting, 27, 35, 373
 —, Shifting Combinations in, 381
 —, Simple, Various Forms of, 31
 —, Single (Glossary), xxxv., 28
 —, Achromatic, 364, 365
 —, with Iris Diaphragm, 31
 —, Non-achromatic, 364
 —, Solar Spectrum of, 354
 —, Spectacle, 363
 —, Spherical Aberration of (Glossary), xxvi., 356
 —, Steinheil's Unifocal, 374
 —, for Stereoscopic Camera, 616
 —, Stigmatic (Glossary), xxxvii.
 —, Aberration of, 356, 357
 —, Stops, Determining Position of, 35, 36
 —, Influence Dot in Half-tone Process, 687
 —, Making, 36
 —, Supplementary (Glossary), xxxvii., 369
 —, Symmetrical (Glossary), xxxvii.
 —, Telephoto (Glossary), xxxvii., 369, 370, 640 (see also Telephoto)
- Lenses, Telephoto, Properties of, 370
 —, Test Photographs of, 366, 367
 —, Testing, 34, 35, 371, 385, 386
 —, for Astigmatism, 35
 —, Chromatic Aberration, 34
 —, Covering Power, 34
 —, Flare Spot, 35
 —, Spherical Aberration, 35
 —, Triplet (Glossary), xxxviii.
 —, "Twist" in, 371
 —, Unar (Glossary), xxxviii.
 —, Universal Orthostigmat, 367
 —, Unifocal (Glossary), xxxix., 374
 —, Use of, 11
 —, Visual Foci, 354, 355
 —, Voigtlander Collinear, 374
 —, Portrait, 365
 —, Water (Glossary), xxix.
 —, Wide-angle (Glossary), xxxix., 32, 35
 —, Rectilinear, 366
 —, Wray Platystigmat, 374
 —, Zeiss, 363
 —, Zonal Aberration of, 356
- Lenticular Stereoscope, 627
 Lermontoff's Experiment, 369
 Lettering and Tinting Negative-, 592
 —, on Mounts, 282
 Level (Glossary), xxvi.
 —, used in Architectural Photography, 552, 553
 Levelling Slab (Glossary), xxvi.
 —, Tripod and Screws for Collotype Plates, 679
 Levi's Cymnograph, 671
 —, Rollograph, 671
 Liesegang's Collotype Process, 683
 Light, Absorption of, 416, 417
 —, Actinic, Reducing Effect of, 222
 —, Actinometer for Testing, 100
 —, Action on Albumenised Paper, 404
 —, Collodio-chloride Papers, 404
 —, Copper Salts, 391
 —, Ferric Salts, 392
 —, Gelatino-chloride Papers, 404
 —, Gold Compounds, 392, 393
 —, Mercuric Salts, 395
 —, Metallic Silver, 389
 —, Potassium Bichromate, 395
 —, Silver Chloride, 389
 —, Compounds, 407
 —, Uranic Salts, 392
 —, Chemical Action of, 388-395
 —, Changes due to, 406
 —, Continuing Action of (Glossary), xvii., 198
 —, Decomposition of (Glossary), xviii.
 —, Dispersion of, 354
 —, and Electricity, Identity of, 394
 —, Filter (Glossary), xxvi., 446
 —, Bausch and Lomb, 446
 —, Deterioration of, 443
 —, for Orthochromatic Photography, 446-449
 —, Fog (Glossary), xxvi.
 —, Intensities, Difference in, 99
 —, Proportional, 99
 —, Intensity, 86-88
 —, Tables, 89
 —, Measuring Strength of, 221
 —, Nature of, 353, 354
 —, Photometer for Measuring, 221
 —, Properties of, 353, 354
 —, Rays, Colours of, 87
 —, Loss of Ultra Violet, 89
- Light, Refraction of, 354
 —, Sensitiveness of, 390
 —, Substances affected by, 393
 —, Testing Intensities of, 99
 —, and Time, Unity of, 415, 416
 —, Trap Doors, Dark-room, 262
 Lighting for Portraiture, 479
 —, Stereoscopic Subjects, 622
 Lighting, Photographing, 611
 Linelight (Glossary), xxvi.
 —, for Photomicrography, 515, 516
 Linear Measure, 718
 Line Drawing Photographs, 718
 Lines in Portraiture, 485
 Linley Beveler, Royle's, 700
 Linley's Process Camera, 890
 Lippmann Colour Photography (Glossary), xxvi., 421-425
 —, Coating Plates for, 421
 —, Development, 422
 —, Emulsion for, 421
 —, Exposure in, 422
 —, Increasing Rapidity of Emulsion, 422
 —, Mounting and Viewing, 425
 Lips, Colouring, 345
 Lithia, Caustic (Glossary), xxvi.
 Lithium Bromide (Glossary), xxvi.
 —, Chloride (Glossary), xxvi.
 —, Hydrate or Hydroxide (Glossary), xxvi.
 —, Iodide (Glossary), xxvi.
 Lithography (see Photo-lithography)
 Litmus (Glossary), xxvi.
 —, Paper (Glossary), xxvi., 172
 —, Using, 172
 Liver of Sulphur (see Potassium Sulphide)
 Lizards, Photographing, 642
 Lizar's Minor de Luxe Camera, 552
 Local Development, 117, 118
 —, Reduction, 145
 Lockett's Method of Intensification, 136
 —, Stereofactor, 630
 Lockyer on Astronomical Photography, 603
 —, Spectrophotography, 570
 Lockyer's Eclipse Photography, 610
 Locomotive, Speed of, 105
 Loewy's Moon Photographs, 605
 Long-focus Lens (Glossary), xxvi.
 Lubricant (Glossary), xxvi.
 Lumière Colour Photography, 423, 424, 430, 431
 —, New Colour Photography, 431
 —, Panchromatic Plates, 425, 444
 —, Alum Trough, 672
 —, Cinematograph, 665, 670, 671
 —, Kinora, 673
 Luminous Photographs, 717
 Lunar Photography (Glossary), xxvi.

M

- McDonough Colour Photography, 429
 Machines, Collotype Printing, 681
 Mackenstein Panoramic Camera, 505
 Maddox, Dr. R. L., 6
 Magic Lantern or Optical Lantern (Glossary), xxix.
 —, Pictures (Glossary), xxvi.
 Magnalium (Glossary), xxvii.
 Magnesium (Glossary), xxvii.
 —, Bromide (Glossary), xxvii.
 —, Chloride (Glossary), xxvii.
 —, Flash-lamp (Glossary), xxi.
 —, Flashlight, 475, 476
 —, Iodide (Glossary), xxvii.
 —, Lamp for Photomicrography, 518
 —, Ribbon Pocket Lamp, 520

- Magnification (Glossary), xxvii.
 Magnifier (Glossary), xxvii.
 —, Focussing (see Focussing Magnifier)
 Malachite Green, 352
 Manganese Sulphate (Glossary), xxvii.
 Manley's Ozotyte Process, 200, 201
 Mansfield, G., 7
 Man Walking, Speed of, 105
 Marechal's Collotype Process, 678
 Marey's Photographic Gun, 664
 Marion's Gum Bichromate Process, 199, 200
 Mariotte (Glossary), xxvii.
 Marriott Printing Frame for Post-cards, 135
 Mars Brown, 352
 — Orange, 352
 — Red, 352
 — Yellow, 352
 Mask (Glossary), xxvii.
 Masking, 157
 — for Combining Portraits, 319
 Masks, Lantern Slide, 320, 321
 Mastic, or Gum Mastic (Glossary), xxvii.
 Matt Papers, 177
 — Surface on Prints (Glossary), xxvii., 292
 — Varnish (Glossary), xxvii.
 Measiness (Glossary), xxvii.
 Measures, Dark-room, 269, 270
 Measures and Weights, 718
 Measuring Glasses, 17
 — Intensity of Light, 518
 Mechanical Washers, 255, 256
 Medallion Vignettes, 158
 Megilp (Glossary), xxvii.
 Meisenbach Process (Glossary), xxvii.
 Meniscus Lens (Glossary), xxvii.
 Mercury Chloride (Glossary), xxvii., 152
 —, Reiss Experiment with, 401
 — Iodide, or Iodide of Mercury (Glossary), xxvii.
 — Intensifier for Negatives, 155
 — Salts, Action of Light on, 393
 Mercury, or Quicksilver (Glossary), xxvii.
 —, Intensification with, 132
 — Vapour Lamp (Glossary), xxvii.
 Metal Mould, Obtaining for Woodburytype Process, 702
 —, Printing on, 696
 —, Sensitising, 696
 —, Transferring Photo-litho Print to, 685
 Meta-gelatine (Glossary), xxvii.
 Meteor, Akuret Print, 190
 — for Interior Photography, 556
 —, Exposure (see Exposure), 99
 Methylated Spirits (Glossary), xxvii.
 Methyllic Aldehyde (Glossary), xxi.
 Mfotol (Glossary), xxviii., 467
 — Developer, 110
 — for Bromides, 223, 229
 —, Factor of, 116
 —, Single Solution, 110
 — and Hydroquinone Developer, 110, 228
 Metol-quinol (Glossary), xxviii.
 Metric System, 718
 — Conversion to British Formulae, 718
 Metzgraph Screen, Wheeler's, 696
 Mica (Glossary), xxviii.
 Microphotography (Glossary), xxviii., 548-551
 —, Apparatus for, 548, 549
 —, Coating Plate in, 549, 550
 —, Exposure in, 550
 —, Focussing in, 549
 —, Lighting in, 549
 —, Microscope, Achromatic Objectives for, 523, 526, 527
 —, Baker's D.P.H., 523
 —, Condensers, Abbe, 532
 —, Bull's-eye, 531
 —, Pan-aplanatic, 532
 —, Watson, 532
 —, Diaphragms, 531, 532
 —, Eyepieces, 527, 528, 530
 —, Compensation, 527
 —, Huygenian, 528
 —, Magnifications of, 529
 —, Fittings, 523-532
 —, Interchangeable Diaphragms for, 533
 —, Iris Diaphragm for, 533
 —, Leitz's, 523
 —, Movements of, 523-532
 —, Nosepieces, 528
 —, Objectives, Achromatic, 525
 —, Apochromatic, 527
 —, Immersion, 527
 —, Magnifications of, 528-531
 —, Zeiss, 527-531
 —, Oculars, 528
 —, Polariscopes, 554, 555
 —, Polariser, 554
 —, Projection Eyepiece, 528
 —, Ross's Standard, 523
 —, Swift's Student's, 525
 —, Trichromatic Photography applied to, 546, 547
 —, Watson's Fram, 525
 Microscopic Work: Anatomical Specimens, 536
 —, Canada Balsam for, 555
 —, Insect Mounting, 556
 —, Live Box for, 558
 —, Magnification Calculation, 539
 —, Maltwood Finder for, 538
 —, Micrometer for, 539
 —, Microtome for, 536
 —, Mineral Mounting, 556
 —, Mounting Specimens, 535-537
 —, Position of Object in, 538
 —, Rousset's Live Box for, 538
 —, Section Cutter for, 536
 —, Turntable for, 536
 —, Vegetable Tissue Mounting, 537
 —, Wood Mounting, 536, 537
 Middle-angle Lens (Glossary), xxviii.
 Middle Distance (Glossary), xxviii.
 Mielhe Anastigmat, 363
 — Powder Process, 457
 — Telephoto Lens, 646
 Mines, Photographing in, 560
 Miniature Painter's Box, 345
 —, Painting, 343, 344
 Minimum Palmos Camera, 509
 Mirror Reflex Camera, 509
 Mirror, Black (Glossary), xiii.
 — for Distorting Photographs, 717
 —, Reversing (Glossary), xxviii.
 Mitre Trimming, 290
 —, Shooting-board for, 290
 Mixing Corner Ornaments, 291
 Molecular Disturbance Theory, 400
 — Formula for Carbon Compounds, 455
 — Strain Theory, 409, 410
 —, Dewar and, 410
 —, and Relapse of Image, 410
 Molybdenum Mica (Glossary), xxviii.
 Monckhoven, Van, 7
 Monckhoven's Intensifier, 154
 Mono-carboxylic Acid, 458
 Monochromatic Light for Photo-micrography, 521
 Monochromatic Photographs of Sun, 607
 — Screen, Gifford's, 521
 Monochrome (Glossary), xxviii.
 —, Rendering Colours in, 444
 —, View Meter, 491
 Monocle (Glossary), xxviii.
 Monumental Work, 586-593
 —, Apparatus for, 587, 588
 —, Artificial Light for, 592
 —, Background for, 583, 589
 —, Correction of Distortion, 593
 —, Development in, 592
 —, Dodges in, 592
 —, Exposure in, 591, 592
 —, Focussing in, 591
 —, Lettering, 592
 —, Light in, 590
 —, Negatives for, 587
 —, Platinotype Process for, 536, 587
 —, Reflectors for, 590, 591
 —, Ruled Focussing Screen for, 588
 —, Tilting Camera Stand for, 588
 —, Tinting Prints, 592, 595
 Moon, Loewy's Photographs of, 605
 —, Photography of, 605, 606
 —, Pickering's Photographs of, 605
 Moonlight Effects in Landscape Photography, 498, 499
 Morgan and Kidd's Ceramic Enamels, 653
 Moser's Experiments with Latent Image, 410
 — Silver Sensitiveness Discovery, 389, 390
 Motay's Collotype Process, 678
 Motional Perspective in Stereoscopes, 634, 635
 Moto-Bijou Camera, 671
 Motograph, Watson's, 671
 Mouldings, Cutting, 290
 —, Frame, 288, 289 (see also Plate 21, facing p. 289)
 —, Gold Slips for, 289
 Mount (see also Mounts, below)
 —, Lens (Glossary), xxviii.
 Mountains in Landscape, 510
 Mountant (Glossary), xxviii., 274
 —, Gelatine, 275
 —, Gutta-percha, 275
 —, India-rubber, 275
 Mounting, Borders and Lettering in, 282
 — on Canvas, 287
 —, Derepas Dry, 281
 —, Dry, 280, 281
 —, Eucastic Paste for, 287
 —, Enlargements, 315
 —, Fancy, 292
 —, with Gelatine, 275
 —, Glazed Prints, 286
 —, Half-tone Blocks, 700, 701
 —, Maxims for, 282
 —, in Optical Contact, 292
 —, Photographs, 274-295
 —, Print before Colouring, 340
 —, Roller Squeegee for, 279
 —, Rubbing Down in, 279, 280
 —, with Sponge, 280
 —, Stretching of Prints in, 281
 — on Wooden Panels, 292
 Mounts, Commercial, 273
 —, Cut-out, 274
 —, Covering, 287, 288
 —, Home-made, 287
 —, India-tint, 275
 —, Injurious Ingredients in, 282
 —, Passe-partouts, 288
 —, Paste-down (Glossary), xxviii.
 —, Photograph (Glossary), xxviii.
 —, Plate-sunk, 273
 —, Slip-in (Glossary), 274
 —, Veneer, 274
 Mouth, in Enlargements, 328
 Mucilage (Glossary), xxviii.

- Multiple-coated Plate (Glossary), xxviii.
- Multiple Photographs, 718
- Mungo Ponton and Carbon Process, 186
- Muriate of Ammonia (see Ammonium Chloride)
- Lime (see Calcium Chloride)
- Muriatic Acid (see Hydrochloric Acid)
- Micrograph, 670
- Microscope, 670, 673
- , Casler's, 673
- Muybridge's Photographs of Moving Horses, 634
- N
- Namias Potassium Permanganate Reducer, 141
- Naphthalene, 467
- Naphthol Green (Glossary), xxviii.
- Yellow (Glossary), xxviii.
- Naples Yellow, 352
- Narrow-angle Lens (Glossary), xxviii.
- Natti Hand Camera, 501, 502
- Natural History Photography, *638—645 (see also Animal Photography)
- Birds' Nests, 641
- Cameras for, 639
- Focal Plane Shutter for, 640
- Lenses for, 640
- Plates, 641
- Reflex Cameras for, *639
- Nebulae, Photographing, 611
- Negative (Glossary), xxviii.
- Air-bubbles on, 127, 128
- Ammonium Persulphate Reducer for, 140—142
- Ascertaining Density of, 225
- Belitzki's Reducer for, 141
- Blackening, with Ammonia, 133
- , by Re-development, 134
- , with Sodium Sulphite, 133
- Bleaching, 132, 133
- Carriers used in Enlarging, *309, 310
- Cloud, Choice of, 161
- Combination, 160
- Copper Bromide Intensifier for, 135
- Defined, 9
- Development in Landscape Photography, 510, 511
- Drying, 20
- Dust Spots on, 127
- Eau de Javelle Reducer for, 140
- Enlarging, *315
- , by Wet Collodion Process, 318
- Examining in Frame, *185
- Ferric Chloride Reducer for, 139
- Ferriyanide Reducer for, 139, 142
- First Production of, 5
- Fixing, 18, 20
- Fogged, Intensification of, 137
- , Reduction of, 145, 144
- Haddon's Reducer for, 142
- Intensification of, 131—137, 402
- Labarraque's Reducer for, 140
- Lead Ferriyanide Intensifier for, 135
- Lens (Glossary), xxviii., 648
- Measuring Density of, 413
- Mercuric Iodide Intensifier for, 135
- Negative, Monckhoven's Intensifier for, 134
- Papers, 85
- Pinholes in, 127
- Potassium Cyanide Reducer for, 140
- Iodide and Hypo Reducer for, 141
- Permanganate Reducer for, 141
- Reducer for, 142
- Preparing, for Printing, 145—162
- Recognising Film Side of, 113
- Reduction of (see Reducers, Reduction, etc.)
- Retouching (see Retouching)
- Spotting Pin-holes in, 150, 151
- suitable for Reduction, 144
- Tone Valves affected by Reduction, 144
- Uranium Intensifier for, 134, 135
- Varnish (Glossary), xxviii., 152
- Varnishing, 151, 152
- Dangers of, 152
- Methods of, 152
- Reasons for, 151
- Washing, 20
- Wellington's Silver Intensifier for, 135, 136
- Nernst-Paul High-power Lamp, 672
- Neuhauss' Bleaching-out Process, 435
- Colour Sensitive Plate, 421
- Neutral Orange, 352
- Newman and Guardia Reflex Camera, 504
- Universal Camera, *505
- Newton's Telescope, *596
- Nicol's Prism for Polariscopes, 534
- Niepe de Saint-Victor, 6, 391, 420
- Niepe, J. N., 4
- Nitrate of Silver, Making, 676
- Nitric Acid (Glossary), xxviii.
- Nitrocellulose (Glossary), xxxiii., 461
- Nitro-hydrochloric Acid (Aqua Regia) (Glossary), xxii.
- Nodal or Gauss Points (Glossary), xxviii.
- Nonactinic (Glossary), xxviii., xxix.
- Norris's Collodion Dry-plates, 6
- Nose, Improving, in Enlargements, 328
- O
- Obneretter's Process (Glossary), xxix.
- Objective (Glossary), xxix.
- Oculars, *528
- Ohm and Grossman's Collotype Process, 678
- Oil, Castor (Glossary), xxix.
- Lamps, Dark-room, 265
- of Vitriol, or Sulphuric Acid (Glossary), xxxvii.
- Oil-immersion Condenser for Microscopes, 532
- Oils, Painting Photographs in, 346—349
- Opacity (Glossary), xxix.
- Meter, Chapman Jones', 418
- Opal Plates, 177, 178
- Opalines, 282
- Backings for, 283
- Borders for, 283
- Opals (Glossary), xxix.
- Open Landscape (Glossary), xxix.
- Optical Centre (Glossary), xxix.
- in Telephoto Lens, 648
- Contact (Glossary), xxix.
- Mounting, 282
- Lantern (Glossary), xxix.
- Optical Lantern Slides (see Lantern Slides)
- Sensitisers (Glossary), xxix.
- Orange Bichromate, Action of, 187
- Vermilion, 352
- Organifier, Photo-ceramics, 654
- Orient Yellow, 352
- Orpiment, 352
- Orthochromatic Photography, 139—455
- Bausch and Lomb Ray Filter for, 446
- Brilliancy in, 448
- Colour Screen for, 446
- Contrasts in, 448
- Dark-room Light for, 451
- Development in, 452
- Flower Studios in, 450
- Graduated Screen for, 446
- Light Filter for, 446—449
- Spectrum Plates for, 452
- Plates (Glossary), xxix., 87
- Cadett and Neall's, 452
- Commercially Prepared, 452
- Development of, 452
- Keeping Qualities of, 452
- for Landscapes, 449, 450
- Portraiture, 450
- Spectrum, 452
- Curve on, 442
- Orthochromatism, Abney and, 443
- , Theories regarding, 442, 443
- Vogel and, 443
- Ortho-dihydroxybenzene or Pyrocatechin (Glossary), xxxiii.
- Orthoscopic Lens, *374
- Orthostigmat (Glossary), xxix.
- Ortol or Ortho-methyl-amidol-phenol (Glossary), xxix.
- Developer, 112
- , Factor of, 116
- Outdoor Portraiture, 485
- Oval Prints, Trimming, 276
- Oven, Drying, for Collotype Plates, 679
- Over-exposure (Glossary), xxix.
- Effect of Bromide in see Plate 5)
- Evidence of, 114
- Treatment of, 114
- Oxalate of Iron (Ferrous Oxalate) (Glossary), xx.
- Oxalic Acid (Glossary), xxix.
- Ox-gall (Glossary), xxix.
- used in Colouring, 541
- Oxide of Chromium, 352
- Oxyalcium Apparatus, Baker's, *515, 516
- , Watson's, *515, 516
- Oxy-chloride Theory, 408, 409
- Abney on, 409
- Baker on, 408
- Hodgkinson on, 403
- Oxygen (Glossary), xxix.
- Oxygenator, Gaumont's, 479
- Oxyhydrogen Light or Limelight (Glossary), xxvi.
- Oxy-magnesium Light for Portraiture, 478
- Ozotype (Glossary), xxix.
- Process, 200, 211
- , Materials for, 201
- , Negatives for, 201
- P
- Packham's Catechu Staining, 211
- Paget XXX Plates, 99
- XXXX Plates, 99
- Painted Backgrounds for Enlargements, 351, 658
- Enamel's, 658
- Painting, Badger Hair Softener for, *348
- , Choice of Print for, 347

- Painting, Colours in, 347, 348
 — from Copy, 346
 —, Dodges used in, 349
 —, Hog Hair Brushes used in, 348
 —, Method of, 348
 —, Photographs in Oils, 346—349
 —, Preparation of Prints for, 347
 —, Varnishing after, 349
 Paintings, Plates and Screens for Copying, 450
 Palladium Chloride (Glossary), xxix.
 Palladium (Glossary), xxix.
 — Toning, 256
 Pan-aplanatic Condenser for Microscope, 532
 Panchromatic Plates, 444, 445
 — —, Dyeing, 444
 — —, Rinsing and Drying, 444
 Panel (Glossary), xxix.
 —, Wooden, Mounting on, 292
 Panoram Kodak, 504
 Panoramic Camera (Glossary), xxix.
 Pantoscopic Camera (Glossary), xxix.
 — Lens (Glossary), xxix.
 Paper (Glossary), xxix.
 — for Albumen Process, 168
 —, Coating, 214—216
 —, Cutting, 181, 182, 216
 —, Drying, 216
 —, Ferro-prussiate, 180
 —, Glossy, 177
 —, Matt, 177
 —, Negative (Glossary), xxix.
 — for Plain Salted Process, 164
 —, Preserving, 216
 —, Reeling, 216
 —, Stretching of, 181, 182
 Papier Velours (Glossary), xxix.
 Papyrography and Papyrotint (Glossary), xxix.
 Para-amido Phenol (see Rodinal)
 Parabolic Reflectors, 545
 — in Enlarging Apparatus, *302, *306
 Paraboloid Reflector (Glossary), xxix.
 Parahydroxyglycine (Glycin) (Glossary), xxix.
 Para-methyl-amido Phenol-sulphate (Glossary), xxviii.
 Paramidophenol Developer, 112
 Paranol (Glossary), xxix.
 Paraphenylene-diamine (Glossary), xxix.
 Passe-partouts, 288
 Paste, Encaustic, 237
 Pastels, 345, 346
 —, Fixing, 346
 Pasting Prints, 279
 Paul's Reliance Animatograph, 665, 666—670
 Payne's Hydroquinone Developer, 708
 Peal Speed Tester, 57
 Pearlash or Potassium Carbonate (Glossary), xxxi.
 Pellet's Process (Glossary), xxix., xxx.
 Pellicle (Glossary), xxx.
 Penrose's Screen Holder for Half-tone, 688
 Pentane (Glossary), xxx.
 — Lamp (Glossary), xxx.
 Perfecto Tripod Stand, 501
 Periscope Lens (Glossary), xxx.
 Permanent Violet, 332
 — White, 352
 — Yellow, 352
 Permits to Photograph, 720
 Persistence of Vision, 664
 Perspective, Aerial (Glossary), x.
 — in Landscape Photography 498
 Petroleum Spirit or Benzoline (Glossary), xlii.
 Petzval Lens (Glossary), xxx.
 — —, Introduction of, 362
 Phantom Development (Glossary), xxx.
 Phenakistoscope, 664
 Phenol, 464
 Phenylamine (Aniline) (Glossary), xli.
 Phenylendiamine (meta), M-phenylendiamine or Sulphate (Glossary), xxx.
 Phosphate of Soda Toning Bath, 247
 Phosphoric Acid, or Trihydrogen Phosphate (Glossary), xxx.
 Photo-aquatint (see Gum-bichromate Process)
 Photo-autocopyist, 677
 Photo-ceramic (Ceramic Photograph) (Glossary), xv., 655, 665
 — Black Enamel, 654, 655
 — Borax Solution for, 655
 — Carbon Process Adapted, 656
 — China, 662, 663
 — Coating with Collodion, 655
 — Plaques and Tiles, 655
 — Combination, Effects in, 657
 — Development in, 654
 — Dusting-on Process, 655, 654
 — Enamels, Painted, 658
 — Exposure in, 654
 — Firing, 658, 660—662
 — Enamel Plaques, 661, 662
 — Furnaces for, 658—661
 — Gas Furnaces for, 658—661
 — Glass-painter's Furnace for, 661
 — Gold and Platinum Bath, 657
 — Iridium and Gold Bath, 657
 — Iron Process, 656
 — Materials for, 665
 — Muffle Furnaces for, 659, 660
 — Organizer for, 654
 — Painted Enamels, 653
 — Photo-mechanical Impression, 656, 657
 — Preparations for Firing, 656
 — Preparing Plate for, 654
 — Rose Colour Test for Firing, 662
 — Sensitizer for, 654
 — Substitution Process, 657
 — Three-colour, 657
 — Transferring Film, 655, 656
 — Vitriifiable Colour for, 654
 — Working in, 653
 Photo-chromoscope, 425—427
 Photo-engraving (Glossary), xxx.
 — Extinction, 406, 407
 Photograph (Glossary), xxx.
 Photogrammetry (Glossary), xxv.
 Photography, Early History of, 2
 — Principles of, 1
 — Progress of, 1
 — Uses of, 1
 Photogravure (Glossary), xxx., 701
 — Fox-Talbot and, 701
 — Process, Developing, 701
 — Etching, 701, 702
 — Graining, 701
 — Klic's, 701, 702
 — Obtaining Prints for, 701
 Photo-lithography (Glossary), xxx., 677
 — Developing Transfer, 684
 — Direct, 685
 — Drying Transfer Paper for, 683
 — Inking-up, 684
 — Velvet Roller for, 684
 — Principle of, 683
 — Printing, 684
 — Sensitising Paper for, 683
 — Transfer Paper for, 683, 684
 — Transferring Print to Metal, 683
 — Stone, 684, 685
 Photo-mechanical Impression:
 — Ceramics, 656, 657
 — Plates (Glossary), xxx., 118
 — Processes, 677—705
 — —, Basis of, 677
 — —, Collotype, 677—683 (for details see Collotype)
 — —, Half-tone, 685—701 (for details see Half-tone)
 — —, Three-colour, 705
 — —, Ives, 705
 — —, Modified, 705
 — —, Obernetter's, 705
 — —, Photogravure, 701, 702 (for details see Photogravure)
 — —, Photo-lithography, 683—685 (for details see Photo-lithography)
 — —, Photozincography, 685
 — —, Stannotype, 702, 705
 — —, Woodburytype, 702
 — —, Work, Three-colour, 456—458
 Photometer (Glossary), 221, 222
 Photomicrography (Glossary), xxx., 512 (see also Plates 13, 25, 27, 33, 34)
 — Acetylene Lamp for, 518
 — Apparatus for, 544, 545
 — Arc Light for, 514
 — Baker's Oxycalcium Apparatus for, 515, 516
 — Beale's Neutral Tint Reflector for, 512
 — Beck's Apparatus for, 516
 — Camera Lucida for, 512, 513
 — Cameras for, 549—541
 — Collingwood Williams and Light Intensity in, 519
 — Coloured Screens for, 522, 523
 — Contact Processes in, 546
 — Correcting for Chromatic Aberration, 542
 — Dark-ground Illumination for, 533, 534
 — Dark Slide for, 544
 — Davis's Focussing Screen, 543
 — Daylight for, 513
 — Developer for, 546
 — Developing Plates, 546
 — Exposure for, 514
 — — of Plate in, 518, 519
 — — Table for, 520, 521
 — Eye-pieces for, 530, 531
 — Focussing, 542, 542
 — Gifford's Screen for, 521
 — Heliostat in, 513, 514
 — High Power, 543
 — — Focussing, 543
 — Hinks' Burners for, 517
 — Illuminants for, 513
 — Incandescent Gaslight for, 517, 518
 — Light Intensity Regulations in, 518, 519
 — Limelight for, 515, 516
 — Low Power, 544
 — Magnesium Lamp for, 518
 — Masking Field in, 550
 — Measuring Intensity of Light, 518
 — without Microscope, 547, 548
 — Microscopes for, 523
 — Monochromatic Light for, 521
 — Oil Lamps for, 516, 517
 — Opaque Objects, 545, 546
 — Parabolic Side Reflector for, 545
 — Paraboloid for, 533
 — Plates for, 546
 — Prism Reflector for, 512, 513
 — Ross's Apparatus for, 516
 — Sanger-Shepherd Process and, 547
 — Sensitometer Screen for, 519
 — Shipnerbottom's Apparatus for, 543
 — Stereo, 547

- Photomicrography, Uses of, 512
 —, Warnerke's Measurement in, 518, *519
 —, Watson's Illuminator for, *546
 —, —, Oxycalcium, Apparatus for, *515, 516
 —, Zeiss Apparatus for, *515, 516, 525
 —, —, Vertical Illuminator for, *545, 546
 —, Zirconia Light for, 518
 Photopake, 187
 Photo-salts (Glossary), xxx., 408, 409, 420
 Photo-sensitive (Glossary), xxx.
 Photo-zincography, 677, 685
 Physical Development (Glossary), xxx.
 Pickering on Astronomical Photography, 602
 Pickering's Photographs of the Moon, 605
 Picric Acid, or Tri-nitro-phenol (Glossary), xxx.
 Pigeon, Speed of, 105
 Pigment (Glossary), xxx.
 Pigments, Chemical Composition of, 352
 —, Permanency of, 351
 Pinachromy, Dr. Koenig's, 437
 Pinacol, or Amido-acetate of Soda (Glossary), xxx.
 Pinhole Photography (Glossary), xxx., 11, 294—299 (see also Plate 11)
 —, Abney's Rule in, 295
 —, Advantages of, 294
 —, Amount of View, 297, 298
 —, Apertures for, 297
 —, Baptista Porta and, 294
 —, Baskett's, 299
 —, Camera for, 294, 295
 —, Copying, 298, 299
 —, Depth of Focus for, 295
 —, Disadvantages of, 294
 —, Enlarging, 298, 299
 —, Estimating Exposure, 297
 —, Finding Diameter of Needle, 296
 —, for High Buildings in, 298
 —, Introduction to, 294
 —, Latitude of Extension, 298
 —, Making Boss, 296
 —, Needle Hole, 296
 —, Reducing, 298
 —, Table of Needles, 295
 Pinholes (Glossary), xxi.
 —, Blackening, 297
 —, Focus of, 295
 —, Mounting, 297
 —, in Negatives, 127
 —, Table of Foci of, 295
 Pins, Bromide Paper, 315
 Pitchblende and Radio-activity, *709
 Pizzighelli Process (Glossary), xxxi.
 Plain Paper (see Salted Paper)
 Planar Lens (Glossary), xxi.
 Planets, Photographing, 606, 607
 Planiscope (Glossary), xxi.
 Planoreflex Camera, 510
 Plant Life, Photographing, 638
 Plaques, Coating, with Collodion, 655
 Plate (Glossary), xxi.
 —, Adapter (Glossary), xxi.
 —, Changing in Landscape Photography, *499, *500
 —, Holder (Glossary), xxxi.
 —, Lifter (Glossary), xxxi.
 —, Recognising Film Side of, 115
 —, Speeds, Cadett's Table of, 412
 —, Determination of, 412—419
 Plate Speeds, H. and D. System of Measuring, 415
 —, Warnerke's System of Measuring, 412
 —, Tester (Glossary), xxxi.
 —, —, Chapman Jones, 452
 —, Whirlier, 272
 Plateau's Phenakistoscope, 664
 Platemark (Glossary), xxxi.
 Plates, 13, 60—84
 —, Actinograph Speed of, 419
 —, Albumen, 83
 —, American Dry Ferrotypes, 119
 —, Ammonia-treated, 72
 —, for Animal Photography, 641
 —, Backing, 555, 556
 —, Barnett Extra Rapid, 99
 —, —, Ordinary, 99
 —, —, Rapid, 99
 —, —, Rocket, 99
 —, Cadett Lighting, 99
 —, —, Ordinary, 99
 —, —, Spectrum, 425
 —, Chromatic, 87
 —, Cleaning, 67
 —, Clearing Solution for, 125
 —, Coating, 68
 —, —, Filling in, 68
 —, Collodion Dry, 6
 —, Colotype, 678
 —, —, Coating with Substratum, 679
 —, —, Drying Oven for, *679
 —, —, Levelling Screws for, *679
 —, —, Tripod for, *679
 —, —, Sensitising, 679
 —, Colour Rendering of (see Plate 35, to face p. 513)
 —, —, Sensitive, 425
 —, Diagonals of, 372
 —, Dry, for Collotype Process, 683
 —, Dry-collodion, 82, 695
 —, —, Emulsion for, 83
 —, —, Finishing, *83
 —, Drying Rapidly, 70
 —, Emulsion for, 60—67
 —, Exposure for, 85—106
 —, Fallacies Regarding, 85
 —, Factors affecting, 85
 —, Ferrotypes, Coating, with Collodion, *81
 —, Glass, 177, 178
 —, Glass for, 68
 —, Ilford Empress, 98
 —, —, Monarch, 98
 —, —, Ordinary, 98, 99
 —, —, Special Rapid, 98, 99
 —, —, Speed of, 419
 —, Imperial Flashlight, 99
 —, —, Special Rapid, 99
 —, Importance of Thorough Washing of, 126
 —, for Interior Photography, *555
 —, Isochromatic, 87
 —, for Landscape Photography, 493
 —, Lantern, 72, 118
 —, Levelling Slab for Coating, *68
 —, Lumière Panchromatic, 425
 —, Machine for Coating, *70, 71
 —, Making 60—79 (see also Emulsion)
 —, Measuring Densities of, *413
 —, Method of Exposing, 13, 85
 —, Multiple-coated, 75
 —, Opal, 177, 178
 —, Orthochromatic, 72, 87, 449—453
 —, —, for Landscapes, 449, 450
 —, —, Over-exposed, 114
 —, —, Paget XXX., 99
 —, —, XXXXX., 99
 —, Panchromatic, 444, 445
 —, —, Photo-mechanical, 118
 —, Pneumatic Holder for, *69
 —, Porcelain Rack for Drying, *126
 Plates, Process, 72, 118
 —, Putting, in Dark Slide, 13, 14
 —, for Radiography, 708
 —, Ready-sensitised Ferrotypes, 119
 —, Removing Pyro Stains from, 125
 —, Sensitive, Speed of, 417
 —, Sensitiveness, 86, 99
 —, Stripping Emulsion from, 676
 —, Under-exposed, 115
 —, Washing, after Development, 114
 —, Wet, 118
 —, Wrongly Exposed, 114, 118
 —, Zinc, Etching, *697
 Plate-sunk Mounts, 273
 Platonic Chloride (Glossary), xxxi.
 Platino-bromide (Glossary), xxxi.
 Platinotype (Glossary), xxxi.
 —, Paper, Coating, 207
 —, —, Damp, Dealing with, 211
 —, —, Old, Dealing with, 211
 —, —, Sensitising, 207
 —, —, Storing, *208
 —, —, Tin for Storing, *208
 —, Prints (see also Plates 2, 9, 10)
 —, —, Ferricyanide of Iron Intensifier for, 210
 —, —, Gold Intensifier for, 210
 —, —, Hubl's Platinum Intensifier for, 210
 —, —, Intensification of, 210
 —, —, Over-exposed, 211
 —, —, Packham's Catechu Staining for, 211
 —, —, Reduction of, 210
 —, —, Staining, with Catechu, 211
 —, —, Toning, with Uranium, 211
 —, —, Under-exposed, 211
 —, —, Process, 205—211
 —, —, Ammonio-ferric Citrate used in, 207
 —, —, Control of Contrasts, 210
 —, —, Developing, 209
 —, —, Experimental Work, 206
 —, —, Ferric Oxalate used in, 207, 208
 —, —, Local Development with Glycerine, 209
 —, —, for Monumental Work, 586, 587
 —, —, Negative for, 208
 —, —, Potassium Oxalate used in, 206
 —, —, Printing, *208, 209
 —, —, Sepia Process, 211
 —, —, Toning Process, 206
 Platinous Chloride (Glossary), xxxi.
 Platinum (Glossary), xxxi.
 —, and Gold Bath for Photoceramics, 657
 —, Printing, Chemistry of, 404
 —, —, Iron Salts in, 392
 —, Recovery of, 676
 —, Salts of, 205
 —, Toning, 239—258, 405
 —, —, of Collodio-chloride Papers, 248
 —, —, Haddon's, 249
 —, —, for P.O.P., 248
 Platystigmat (Glossary), xxxi.
 Playertype (Glossary), xxxi.
 Plumb Indicator (Glossary), xxxi., *552
 Pneumatic Holder (Glossary), xxxi., *68
 —, Release (Glossary), xxxi.
 Pocket Dark-room, *129
 Poitevin Collotypes, 678
 Poitevin's Colour Photography, 420
 —, Experiments, 390, 391
 Polariscopes, *534, 535
 —, Nicol's Prism for, *534, 535

- Polariser, 534
 Polychrome (Glossary), xxxi.
 Polymerism: Carbon Compounds, 457, 458
 P.O.P. (see Printing Out Paper)
 Porcelain Clay (Kaolin) (Glossary), xxv.
 --- Tray for Colours, *340
 Porro's Telephotography, 646
 Portable Dark-room, *259, *260
 --- Oil Enlarging Lantern, *306
 Portrait Lens (Glossary), xxxi., *365
 Portraits, Introducing Back-grounds into, 159, 160
 Portraiture, 469-488
 --- Acetylene for, 478
 --- Animals, *482, 483
 --- Artificial Light for, 473, 474
 --- Backgrounds, 471, 472, 479
 --- Balance in, *483, *484
 --- Camera for, *437, 438
 --- --- Stand for, *488
 --- Children, *482, 483
 --- Chiaroscuro in, 484
 --- Dallmeyer Cabinet Attachment for, *483
 --- Daylight for, 479
 --- Electric Light for, 474
 --- Flash Lamps for, *476
 --- Flashlight, 477, *478
 --- --- Installation for, 477
 --- Good Composition in, 484
 --- Group Arrangement, 482
 --- Head Rest for, *431
 --- --- Screens for, 473
 --- Hewitt Mercury Vapour Lamp for, 479
 --- Incandescent Gas for, 475
 --- Indoor, 470
 --- Lighting for, 479
 --- Magnesium Flashlight for, 475, 476
 --- Orthochromatic Plates for, 450
 --- Outdoor, 469, 485
 --- Oxy-magnesium Light for, 478
 --- Portable Canvas Studio for, *485, 486
 --- Posing for, 480, 481, 485
 --- --- Chair for, *481
 --- Position of Camera in, 484
 --- Reflectors for, *473
 --- in Room, Exposure for, 99
 --- Rooms for, 487
 --- Softness of Light in, 480
 --- Straight Lines in, 483
 --- Studio, *469, 472
 --- --- Greenhouse as, *486, 487
 --- Taste Required for, 433
 --- Todd-Forret Magnesium Lamp for, *476
 --- Types of Faces, 480
 --- --- Figures, 485
 --- Use of Repeating Back, 488
 --- White Posing Chair for, *481
 Posing Chair, *481
 Positive (Glossary), xxi., 9
 --- Lens (Glossary), xxxi., 648
 Postcards, Marriott Printing Frame for, *183
 Potash Alum (see Alum)
 --- Bichromate or Red Chromate of (Potassium Bichromate) (Glossary), xxxii.
 --- Subcarbonate of (Potassium Carbonate) (Glossary), xxi.
 Potassium Bichromate (Glossary), xxxii.
 --- Action of, 187
 --- Injurious Effects of, 194
 --- Reducer, 142
 --- Bromide (Glossary), xxxi.
 --- Carbonate (Glossary), xxxi., 103
 --- Chlorate (Glossary), xxxi., xxxii.
 --- Chloroplatinite (Glossary), xxxii.
 --- Citrate (Glossary), xxxii.
 Potassium Cyanide (Glossary), xxxii.
 --- Reducer, 140
 --- Dichromate (Glossary), xxxii.
 --- Ferric Oxalate (Glossary), xxxii.
 --- Ferrieyanide (Glossary), xxxii.
 --- Ferrocyanide (Glossary), xxxii.
 --- Hydrate, or Caustic Potash (Glossary), xxxii.
 --- Iodide (Glossary), xxxii.
 --- and Hypo Reducer, 141
 --- Metabisulphite (Glossary), xxxii.
 --- Oxalate (Glossary), xxxii.
 --- Developer, 399
 --- used in Platinotype Processes, 206
 --- Perchlorate (Glossary), xxxii.
 --- Permanganate (Glossary), xxxii.
 --- Reducer, 141
 --- Platino-chloride (see Potassium Chloroplatinite)
 --- Sulphide (Glossary), xxxii.
 Potonium, 709
 Pouncy's Carbon Process, 198
 Powder Process (Glossary), xxxii.
 --- of Colour Photography, 437
 Praxinoscope, Reynaud's, 664
 Preno Camera, 509
 Press, Emulsion, *71
 Presses, Collotype Printing, *681
 Prestwich Junior Camera, 671
 Putsch Collotypes, 678
 Primrose Yellow, 352
 Primuline Process (Glossary), xxxii.
 Primus Camera, 510
 Print, Advantages of Working-up, 325
 --- Albums, 292
 --- Burnishing, *283, *285
 --- Clip, *246
 --- Colouring, with Dyes, 351
 --- Defined, 9
 --- Disadvantages of Working-up, 325
 --- Enamelling, 286, 287
 --- Examining, in Frame, *21
 --- Fixing, 21
 --- Glazed, Mounting, 286
 --- Glazing, 286
 --- Indicators, *183, 184
 --- Knowledge of Drawing in Working-up, 325
 --- from Leaf, 9
 --- Matt Surface on, 292
 --- Meter, Akuret, *190
 --- from Negative, 9, 10
 --- Pasting, 279
 --- Rolling, 283
 --- Rules for Trimming, 278
 --- Solution for Toning, 21
 --- Spotting, 326-327
 --- Stability of, 251
 --- Stretching in Mounting, 281
 --- Thorough Washing of, 250, 251
 --- Tinting with Dyes, 351
 --- Toning, 21
 --- Trimmer (Glossary), xxxii.
 --- Trimming, 275-278
 --- --- Machines for, *277
 --- Unmounted, Flattening, 292
 --- Untoned, Preserving, 241
 --- Washers, Mechanical, *255
 --- Washing, 255
 --- Working-up, in Monochrome, 325-336
 Printing, 20
 --- Choice of Paper for, 164
 --- Combination, *158-162
 --- Defined, 9
 --- Development Processes of, 186-238
 --- Discovery of, 3, 4
 --- First Lesson in, 21
 --- Frame (Glossary), xxxii., *20, 182
 --- --- Backs, *182, *183
 --- --- Examining Negative in, *183
 --- --- Flat, *182
 --- --- for Gelatino-chloride Plates, *178
 --- --- Jaynay Non-slipping, *183
 --- --- for Lantern Slide, *320
 --- --- Large Negatives, *182
 --- --- Marriott, *183
 --- --- Non-slipping, 183
 --- --- Pad (Glossary), xxxii.
 --- --- on Large Scale, 184
 --- --- Machines and Presses, Collotype, *681
 --- --- on Metal, 696
 --- --- Photo-litho, 684
 --- --- Out (Glossary), xxxii.
 --- --- Davis's Method of, 163
 --- --- Paper, or P.O.P. (Glossary), xxxii., 21, 163-185
 --- --- Choice of, 164
 --- --- Cutting, *181, 182
 --- --- Plain Salted, 163-166
 --- --- Salting, 165
 --- --- Sensitising Solution for, 166
 --- --- Sizing, 164-166
 --- --- Stretching of, 181
 --- --- Processes, 163-185
 --- --- Cheap, 181
 --- --- Plain Salted, 163
 --- --- Sensitive Paper for, 21
 --- --- Sheds, *184, 185
 --- --- Watching Progress of, *183
 --- --- Wedgwood's Method of, 163
 --- --- with Radium, 710
 --- Prints, Radiographic, *710
 --- --- Stereoscopic, Making, 624
 --- --- Mounting, 624
 --- --- Transposing, 623
 --- --- Trimming, 623, 624
 Prism (Glossary), xxxii.
 --- for Process Camera, *693
 Process Cameras, *890
 --- Plates, 118
 Professional Chrono Projector, *670
 Projection, Stereoscopic, 630
 Projector, Professional Chrono, *670
 Proportional Scale (Glossary), xxxii.
 Protar (Glossary), xxxii.
 Protosulphate of Iron (see Ferrous Sulphate)
 Proving in Half-tone Process, 700
 Prussiate of Potash (see Potassium Ferrieyanide)
 Prussian Blue, 352
 Pulp Slab (Glossary), xxxii.
 Pyro (Glossary), xxxiii.
 --- Developer, Accelerators for, 108
 --- --- Factor of, 116
 --- --- Formula, 107
 --- --- and Acetone Developer, 109
 --- --- Ammonia Developer, 109
 --- --- Metal Developer, 109
 --- --- Soda Developer, 18, 109
 --- --- --- Factor Six, 116
 --- --- Stock Solution, Factor Six, 116
 Pyrocatechin, or Ortho-dihydroxy-benzene (Glossary), xxxiii.
 --- Developer, 112
 --- --- Factor of, 116
 Pyrogallie Acid (Glossary), xxxiii.
 --- Developer, 107
 Pyrogallol (Glossary), xxxiii., 465
 --- Developer, 107

Pyroxyline (Glossary), xxxiii., 461
 —, Preparation of, 75
 —, Qualities of, 74

Q

Quarter Plate (Glossary), xxxiii.
Quincey (Developing Box), *129
Quinol (see Hydroquinone)
Quinoline (Cyanine) (Glossary),
 xviii.
Quinomet (Glossary), xxxiii.
Quata Frototype Camera, *119

R

Rack and Pinion (Glossary), xxxiii.
Racks, Dark-room, *263, *269
 — for Drying Negatives, *20, 126
Radicals: Carbon Compounds, 456
Radio-active Substances, 708
 —: Pitchblende, 709
 —: Radium, 709
 —: Uranium, 709
Radiographs, Bromide Paper for,
 708
 — of Coins, 709
 — on Paper, 708, 709
Radiography, *704—711
 —: Apparatus for, *706, 707
 —: Apps' System, 708
 —: Crookes' Spintharoscope, 710,
 711
 —: Crookes' Tubes for, 706, 707,
 708
 —: De la Rue's Experiments, 706
 —: Developer for, 708
 —: Edwards and, 707, 709
 —: Exhausting Tube for, 707, 708
 —: Ferrous Oxalate Developer
 for, 708
 —: Fluorescence of X-ray Tube,
 707
 —: Fluorescent Screen for, 704,
 711
 —: Focus Tube for, *706, 707
 —: Geissler Tubes for, 706
 —: Hertz and, 704
 —: Holtz Machine for, 706
 —: Hydroquinone Developer for,
 708
 —: Isenthal and, 707
 —: Jackson's Focus Tube for,
 *706, 707
 —: Lenard and, 704
 —: Payne's Hydroquinone De-
 veloper for, 708
 —: Plates for, 708
 —: Plates enclosed in Envelopes,
 705
 —: Precautions for, 707
 —: Röntgen and, 704
 —: Screen for, 704, 711
 —: Source of Electricity, 705, 706
 —: Spintharoscope, *710, 711
 —: Spottiswoode's Tubes for, 706
 —: Swinton's System, 708
 —: Using Current from Street
 Main, 708
 —: "Vacuum" in Tubes, 707
 —: Wimshurst Machine for, 706
Radiometer, Crookes', *394, 395
Radiotint Process, 351
Radium, 709, 710
 —, Atomic Weight of, 710
 —, Photographic Action of, 710
 —, Printing with, 710
Rajar Changer, 53
Ramsay and Astronomical Photo-
graphy, 605
Ramsden's Telescope Eyepiece, 598,
 599
Rapid Emulsion (Glossary), xxxiii.
 — Rectilinear Lens (Glossary),
 xxxiii.

Rapid Symmetrical Lens (Glos-
 sary), xxxiii.
Rapidity (Glossary), xxxiii.
Rayleigh on Colour Photography,
 421
Rayleigh's Ferric Chloride Experi-
ments, 392
Ray's Stereo-anima-photography,
 632
Rectigraph Lens (Glossary), xxxiii.
Rectilinear Lens (Glossary), xxxiii.
Red Chromate of Potash or Potas-
sium Dichromate (Glossary),
 xxxii.
 — Fog (Glossary), xxxiii.
 — Light, Developing Power of, 390
 — Silver Chloride Experiments,
 420
Reducer (Glossary), xxxiii., 103
 —, Ammonium Persulphate, 140—
 142
 —, Baskett's, 139
 —, Belitzski's, 141
 —, Chemical, 138
 —, Clearing Solution used as, 142
 —, Eau de Javelle, 140
 —, Eder's, 401
 —, Effect of, 141, 142
 —, Farmer's (Glossary), xxxiii.,
 402
 —, Ferric Chloride, 139, 140, 401
 —, Ferricyanide, 139, 142, 402
 —, Fixing Solution used as, 142
 —, Haddon's, 142
 —, Labarraque's, 140
 —, Physical, 138, 139
 —, Potassium Bichromate, 142
 —, Cyanide, 140
 —, Iodide and Hypo, 141
 —, Permanganate, 141
Reducing Agent (Glossary), xxxiii.
Reduction (Glossary), xxxiii., *138
 —144, 401
 — by Expansion, 143
 —, Local, 143
 —, Desk for, *143
 —, Necessity of, 138
 —, Negatives Suitable for, 144
 —, Risk with, 144
 — and Tone Values, 144
Reflected Photographs, 718
Reflector (Glossary), xxxiii.
 — Camera, 509
 — for Monumental Work, *590
 — Portraiture, *473
Reflex Camera (Glossary), xxxiii.,
 639—640
Refraction (Glossary), xxxiii., *354
 —, Index of (Glossary), xxiv.
Reiss' Experiment with Mercuric
Chloride, 401
Relief in Stereoscopic Photography,
 615, 630
Reliefs, Gelatine, from Dry Plates,
 705
Rembrandt Portrait (Glossary),
 xxxiii., *487
Repeating Back (Glossary), xxxiii.
Reproduction Cameras, *890
Reptiles, Photographing, 642, 643
Residues (Glossary), xxxiii.
 —, Advisability of Collecting, 674
 —, Filtering, *674
 —, Fletcher's Injector Furnace
 for, 675
 —, Recovering Platinum from, 676
 —, Silver from, 675, 676
 —, Uranium from, 676
 —, Treatment of, 674—676
Resin, or Rosin (Glossary), xxxiii.
Resorcin-plithaleim (Fluorescin),
 (Glossary), xxi.
Restrainers (Glossary), xxxiii., 108
Retardation (Glossary), xxxiii.
Retouched Photograph (see Plate
 7, facing p. 97)
Retouching (Glossary), xxiii., 145
 —, Applying Medium in, 146, 147

Retouching, Cross-hatching in, *149
 — Desk (Glossary), xxxiv., *146
 —, Dotted in, 149
 —, Experiment in, 148
 — Face in Portrait, 149
 — Knife, *145
 —, Using, 146
 —, Materials for, 145
 —, Matt Varnish for, 149
 —, Medium (Glossary), xxxiv., 145
 —, Methods of, 147, 148
 —, Modelling Features by, 149
 —, Pencil, Sharpening, *147
 —, Position for, 148
 —, Scumbling in, *149
 —, Spotting in, 150, 151
 —, Stereoscopic Negatives, 623
 —, Stippling in, *149
 —, Strokes used in, 149, *150
 —, Touches for, 149
Reversal or Solarisation (Glossary),
 xxxiv., 400, 401
Reversed Negative (Glossary),
 xxxiv.
 — Print (Glossary), xxxiv.
Reversing Back (Glossary), xxxiv.
Revolver, Janssen's Photographic,
 664
Revolving Stereoscope, 623
Reynaud's Praxinoscope, 664
Rice's Stereoscopic Printing
 Frame, *625
Rings for Pictures, *290
Ripening Emulsion, 410
Rising Front (Glossary), xxxiv.
Ritter, J. W., 3
Rives Paper (Glossary), 168
Robinson, H. P. and Combination
Pictures, 159, 160
Rochelle Salts (Glossary), xxxiv.
Rodinal (Glossary), xxxiv., 466
 — Developer, 112
 —, Factor of, 116
Rohr's Verant, 630
Rollagraph, 671
Roller Burnishers, *284—286
 —, Using, *284, 285
Roller-slide, or Roll-holder (Glos-
 sary), xxxiv.
Roll-film Camera (Glossary), xxxiv.
Roll-holders, 58
Rolling Prints (Glossary), xxxiv.,
 283
Röntgen Rays and Radiography,
 *704—709
Room for Enlarging, 310
 —, Portraiture in, 99, 487
Ross's Apparatus for Photomicro-
graphy, *516
 — Camera, 509
 — Lens, 362
 — Microscope Lenses, 527
 — Standard Microscope, *523
Rotating Back (Glossary), xxxiv.
 — Stops (Glossary), xxxiv.
Rothé's Colour Photography, 423
Roto-bioscope, 671
Routing, in Half-tone Process, 700
 — Machine, Royle, *699
Kowland's Gratings, 579
Royl's Lining Revolver, 700
 — Routing Machine, *699
Rubbing Down in Mounting, *279,
 280
Ruby Lamp (Glossary), xxxiv.
Rudolph, Dr. P., 363
Ruled Screen (Glossary), xxxiv.
 — for Half-tone Work, *686
Russell, Major, 6

S

Safe Edge (Glossary), xxiv.
Saint-Victor, Niépce de, 6, 391, 420
Sal-ammoniac (see Ammonium
 Chloride)
Salmon's Vignetter, *155

- Salomon's Table of Depth of Focus in Lens, 362
- Salt of Tartar or Potassium Carbonate (Glossary), xxxi.
- Salted Paper (Glossary), xxxiv., 165-166
- Sandarac (Glossary), xxxiv.
- Sandell Cristoid Film, 122, *123
- Pyro and Metol Developer, 109
- Sanderson Camera, *552
- Sanger-Shepherd Colour Photography, 429, 430
- Process and Photomicrography, 547
- Saxe Paper, 163
- Sayce, B. J., 6
- Scale of Focussing Hand Camera, Graduating, 373
- Scales and Weights, Dark-room, *270
- Scarlet, Pure, 352
- Vermilion, 352
- Scheele's Discoveries and Experiments, 3, 163, 392
- Schlippe's Salt (Glossary), xxxiv.
- Intensifier, 137
- Schölzig, Mr. Otto, 251, 252
- Schott's Glass, 362
- Schumann's Experiments, 391
- Scott-Archer's Collodion Process, 6
- Scott's Light Intensity Variation Tables, 87-89
- Scraping and Erasing Prints, 333
- Screen (see also Focussing Screen, Isochromatic Screen)
- , Colour, Deterioration of, 443
- , Fluorescent, 704, 705
- , Making, 711
- Holder (Glossary), xxxiv.
- , Penrose's, *688
- , Making Graduated, 447
- , Ruled, for Half-tone Work, 686
- Seebeck's Colour Photography, 420
- Discoveries, 391
- Sel d'Or (see Gold Hyposulphite)
- Selective Sensitisers (see Optical Sensitisers)
- Self-toning Paper (Glossary), xxxiv.
- Senebier's Discoveries in Actinism, 3, 391
- Senior's Emulsion, 421, 422
- Sensitisers (Glossary), xxxiv., 410, 411, 460
- , Collodion, 6
- , Colour, 445, 446
- , Photo-ceramic, 654
- , Theory of, 411
- Sensitising (Glossary), xxxiv.
- Albumen Paper, 169-174
- Collotype Plates, 679
- , Dyes used for, 445
- Metal, 696
- Photo-litho Paper, 683
- Silk, 171
- Solution for Bitumen Process, 698
- , Solution, Testing, 172
- , Wood, *171
- Sensitive Materials, 15
- Sensitiveness of Plate, 86
- Sensitometer (Glossary), xxxiv.
- , Spurge's, 412, 413
- Sepia Bromides, 234, 235
- Paper (Glossary), xxiv.
- Process, 211, 212
- , on Silk or Satin, 211
- Shadowgraph (Glossary), xxxiv.
- Sheath (Glossary), xxxiv.
- Sheds, Printing, *184, 185
- Shellac, or Gum Lac (Glossary), xxxiv.
- Shelves, Dark-room, 263, 264
- Shielding (Glossary), xxxiv.
- Ship Moving, Speed of, 105
- Shipperbottom's Photomicrographic Apparatus, *543
- Shooting-board, *290
- Shutter (see also Instantaneous Shutter)
- , Blind (Glossary), xiii.
- , Everset (Glossary), xx., 55, *56
- , Flap, 55
- , with Pneumatic Action, *55
- , Focal Plane, *55, 640
- , Making, *714
- , Peal Speed Tester for, *57
- , Seesaw, *55
- , Stereoscope, *56
- , Studio Bellows, *56
- , Testing Speed of, 57
- Shutters, Camera, *54-57
- Sickle Camera, 510
- Side-by-side Stereoscopic Projection, *631, 632
- Siderostat, *609, *610
- Silhouette (Glossary), xxxiv., 718
- Silk Printing (Glossary), xxxv.
- , Sepia Process on, 211
- Silver (Glossary), xxxv.
- Ammonio-nitrate (Glossary), xxxv.
- , Bath, Argentometer for Testing, *173
- , Clearing, *173
- , Keeping, in Order, 172
- , Regulating, after Clearing, 174
- , Testing Strength of, 173
- , for Wet Collodion Process, 76
- Bromide (Glossary), xxxv.
- Chloride (Glossary), xxxv.
- , Action of Light upon, 165, 389
- , Preparation of, 163
- , Printing Paper, 163
- , Recovering, 674, 675
- , Red, Experiments with, 420
- Compounds, Photo-chemistry of, 407
- , Image, Growth of, 399
- , Intensifier, Wellington's, 135
- , Iodide (Glossary), xxxv.
- , Nitrate (Glossary), xxxv., 163
- , Making, 675
- , Origin of Reduced, 398
- , Oxide (Glossary), xxxv.
- , Print (Glossary), xxxv.
- , Fixing, 252, 253
- , Bath for, 253
- , Process, 167
- , Salts, Effect of Spectrum on, 391
- , Subhaloids (Glossary), xxxv.
- , Sulphide (Glossary), xxxv.
- , Making, 675
- , Washings and Cuttings, 674
- , Zinc Method of Recovering, 676, 677
- Simpson's Collodio-chloride Process, 178
- Single Lens (Glossary), xxxv.
- Transfer (see Carbon Process)
- Sinop Collotype Process, 682, 683
- Sizing Printing-out-paper, 163
- Skies in Enlargements, *313, 314
- , Printing in, 160, 161
- Sky and Foreground in Landscape Photography, *495, 496
- Skylark, Speed of, 105
- Sky-shade (Glossary), xxxv.
- Slab, Pulp (Glossary), xxxii.
- Slide (see Dark Slide, Lantern Slide)
- Slip-in Mounts, 274
- Small, 352
- Snap-shot (Glossary), xxxv.
- Developer, 111
- Soap, Castile (Glossary), xxxv.
- Soda Saltpetre or Sodium Nitrate (Glossary), xxxvi.
- Sodium Acetate (Glossary), xxxv.
- , Biborate (see Borax)
- , Bicarbonate (Glossary), xxxv.
- , Carbonate (Glossary), xxxv., 108
- , Chloride (Glossary), xxxv., xxxvi.
- , Formate (Glossary), xxxvi.
- , Hydrate (Glossary), xxxvi.
- , Hyposulphite, or Thiosulphate (Glossary), xxxvi.
- , Nitrate (Glossary), xxxvi.
- , Oxalate (Glossary), xxxvi.
- , Sillicate (Glossary), xxxvi.
- , Sulphite (Glossary), xxxvi.
- , Intensifier, 402, 403
- , Thiosulphate (Glossary), xxxvi.
- , Preparing, 253
- , Tribasic Phosphate (Glossary), xxxvi.
- , Tungstate (Glossary), xxxvi.
- Soho Camera, 509
- Sol Spirit Lamp, *324
- Solar Camera (Glossary), xxxvi.
- , Spectrum, *354
- Solarisation (Glossary), xxxvi., 400, 401
- Solutions: Keeping Temperature Constant, 66
- , Ten-per-cent., Making (Glossary), xxxviii., 270, 271
- Spectra, Photographing, 441
- Spectrography: Fraunhofer Lines, 570, 571
- , Wollaston and, 570
- Spectrometer (Glossary), xxxvi.
- , Adjustment, *580
- , Collimator, 582
- , Eyepiece, 565
- , Making, 580-584
- , Prism Table, *582
- , Slit, *582, 583
- , Spark Gap, *583, 584
- , Standards, *582
- , Telescope, 583
- , Carrier for, 581, *582
- Spectrophotography (see Plates 16 and 36)
- Spectrophotography, *440, 562-585
- , Arc and Sun, 572
- , Bolometer for, 566
- , Concave Gratings, 578, 579
- , Deviation, *576
- , Curves in, *567
- , and Wave-length in, 565
- , Diffraction Grating, *574-576
- , Spectra for, 573
- , Effects of Wave Disturbance in, *574
- , Incandescent Gas for, *568, 569
- , Langley on, 566
- , Light for, 567, 568
- , Lockyer and, 570
- , Plates for, 565, 566
- , Reflection Gratings, 577, 578
- , Rowland's Gratings, 579
- , Spectra Compared, *571, 572
- , Spectrum Formation, 577
- , Sunlight for, 569, 570
- , Transmission Gratings, 576, 579
- , Wimshurst Induction Machine for, *569
- Spectrophotometer (Glossary), xxxvi.
- Stereoscope, Attaching Telescope to, 604
- Stereoscopic Apparatus, *440
- , Phenomena, Photographing, 608
- Spectrum, Artificial, Experiments with, 443
- , Curve on Orthochromatic Plate, *442
- , Heliograph, *607
- , Luminosity of, *440
- , Photographing the, *563-566

- Spectrum, Solar (Glossary), xxxvi.
 —, Virtual, 562, 563
- Speed Indicator (Glossary), xxxvi.
- of Moving Objects, Estimating, 105
- Sensitive Plates, 417
- Speeds, Plate, 412—419
- , Proportionate, for Exposure, 98
- Spherical Aberration (Glossary), xxxvi.
- Spinhariscope, Crookes', 710
- Spirit Lamp, Sol (Glossary), *324
- Spirit Photography (Glossary), xxxvi.
- Spirits of Wine (see Alcohol)
- Sponge for Mounting, 280
- Spot Spectra, 608
- Spots in Stereoscopic Photography, 625
- Spotting (Glossary), xxxvi.
 —, Medium, 326
 —, Prints, 326
 —, Applying Colour in, 326
 —, Materials for, 326
 —, Mixing Colour for, 326
 —, Supporting Print for, *327
- Spottiswoode and Geissler Tubes, 706
- Spurge's Sensitometer, 412, 413
- Square Bellows, Making, *712
- Squeegee (Glossary), xxxvi.
 —, for Carbon Prints, *190
 —, Roller, *279
- Stains, Hypo, Treatment of, 257
- Stamp Photographs (Glossary), xxxvi.
- Stand Development (Glossary), xxxvi., 117
- Stands, Camera, *50
 —, for Architectural and Monumental Work, *54
 —, Featherweight, *50
 —, Studio, *51
 —, Making, *51—54
 —, Spring Catch for, *52
 —, with Weight and Pulleys, *53
 —, Winch and Rackwork for, *52
 —, Telescopic, *54
 —, Tripod, Care of, 28
 —, Turntables for, *50
 —, Walking Stick, *54
- Stannotype (Glossary), xxxvi.
 —, Process, 702, 703
- Starch (Glossary), xxxvi.
- Stars, Photographing, 606, 607
- Stas Gelatine Plate, 6
- Steinheil's Rapid Rectilinear Lens, 363
 —, Telephoto Lens, 646
 —, Unofocal Lens, *374
- Stereo-anima-photography, 652
 —, Aspray and, 652
 —, D'Almeida and, 652
 —, Fisher and, 652
- Stereo-cinematograph Camera (Glossary), xxxvii., 633
- Stereofactor, Lockett's, 630
- Stereogram, Phases Missing in, 615
 —, Animated, 637
- Stereo-photo-duplicon (Glossary), xxxvi.
 —, Brown's, *620, 621
- Stereo-photomicrography, Druner's Camera for, *547
 —, Turner's, *547
- Stereo-projection, Direct (Glossary), xviii., 653
- Stereopticon, *630
- Stereoscope (Glossary), xxxvi.
 —, Achromatic Lens for, 628
 —, Automatic, 628
 —, Brewster, 627
 —, Elliott, *626
 —, Grubb, 628
- Stereoscope, Holmes Lenticular, *627, 628
 —, Lenticular, 627
 —, Revolving, *628
 —, Varying Refractive Angle in, 628
 —, Wheatstone, *626, 627
- Stereoscopic (Glossary), xxxvii.
 —, Adapter, *618
 —, Brown's, *619
 —, Camera (Glossary), xxxvii., 620
 —, Baseboard, 620
 —, Lens, 616, 617
 —, Cinematograph Projection, *633
 —, Photographs (see Plates 28, 38, 40)
 —, Photography, 612—637
 —, Adjustment of View Points, *620, 621
 —, Axial Adjustment of Eye in, 613
 —, Binocular Perception, 614, 615
 —, Vision in, *613, *614
 —, Brown's Stereo-photo-duplicon for, *620, 621
 —, Transmitter for, *619
 —, Cinematograph Camera for, *636
 —, Circumscribing Subject in, 636, 637
 —, Developing Negatives in, 622, 623
 —, Dissimilar Pictures in, 615, 616
 —, Duplicate Cameras for, 621, 622
 —, Exposures in, 619, 620
 —, Eye Accommodation in, 612
 —, Floral Subjects in, *622
 —, Focal Changes in, 612, 615
 —, Moving Subject in, 618, 619
 —, Progressive Pictures in, 636, 637
 —, Relief in, 615, 630
 —, Retouching Negatives in, 623
 —, Single Lens Work in, 617, 618
 —, Slotted Board for, *617
 —, Spots in, 623
 —, Transposition of Prints, 617, 623
 —, Tryhorn and, *622
 —, Printing Frame, Rice's, *625
 —, Prints, Masking, 624
 —, Mounting, 624
 —, Transposition of, 617, 623
 —, Trimming, 623, 624
 —, Projection, *630—636
 —, Anderson's Polarising System of, 632
 —, Brown's, *634—636
 —, D'Almeida and, 630, 631
 —, Direct, 633, 634
 —, Dore and, 630
 —, Ducos du Hauron and, 630
 —, Eclipse System of, *631
 —, Motional Perspective in, 634, 635
 —, Relief, *635, 636
 —, Side-by-side, *631, 632
 —, Stereopticon for, *631
 —, Wilson's, 632, 633
 —, Relief, 615, 630
 —, Transparencies, 625, 626
 —, Binding, 626
 —, Printing Frame for, *625
 —, Vision, *628, 630
- Stigmatic Lens (Glossary), xxxvii.
- Stock Solutions (Glossary), xxxvii.
- Stone, Transferring Photo-litho Print to, 684, 685
- Stopping Down (Glossary), xxxvii., 361, 494
- Stopping Down in Telephoto Lens, 650
 —, Out, 699
- Stops, or Diaphragms (Glossary), xxxvii.
 —, Use of, in Exposures, 86
- Stripping Film (Glossary), xxxvii.
- Strokes used in Retouching, 149, *150
- Strontium Chloride (Glossary), xxxvii.
- Studio Accessories, 472
 —, Blinds, *470, 471
 —, Camera (see Camera)
 —, Stands, *51—54
 —, Dimensions of, 469, 470
 —, Finding Length of, for Given Lens, 719
 —, Furniture for, 472
 —, Glazing, 470
 —, for Half-tone Process, 688
 —, Heating, 471
 —, Lighting (see Plates 19, 20)
 —, Portable Canvas, *485, 486
 —, Shutter (Glossary), xxxvii.
 —, Sun-boards, 471
 —, Ventilation, 471
 —, Work (see Plate 24)
- Stumping, 352
- Subject, Choice of, for Beginners, *14
- Submarine Photography, 560, 561
- Sub-salts, Doubtful Existence of, 407, 408
 —, Emszl on, 408
 —, Fischer on, 407
 —, Guntz on, 408
 —, Theory of, 407
 —, Vogel on, 408
 —, Von Bibra on, 407, 408
 —, Waterhouse on, 408
 —, Wetzlar on, 407
 —, Wöhler on, 407
- Sulphantimonate of Soda (Glossary), xxxiv.
- Sulphide Toning (Glossary), xxxvii.
- Sulphur Toning (Glossary), xxxvii.
- Sulphuret of Ammonium (see Ammonium Sulphide)
- Sulphuric Acid (Glossary), xxxvii.
- Sulphurous Acid (Glossary), xxxvii.
- Sun, Monochromatic Photographs of, 607
 —, Photography, 600—604
- Sun-boards, Studio, 471
- Sunning-down (Glossary), xxxvii.
- Sunset Effects in Landscape Photography, 498, 499
- Supplementary Lens (Glossary), xxxvii.
- Suter Camera, 509
- Swan's Introduction of Carbon Process, 186
- Swantype (Glossary), xxxvii.
- Swift's Student's Microscope, *523
- Swing Back (Glossary), xxxvii.
- Swinging Easel (Glossary), xxxvii.
 —, Front (Glossary), xxxvii.
- Swinton, C., and Radiography, 708
- Symmetrical Lens (Glossary), xxxvii.
- Synthol (Glossary), xxxvii.
 —, Developer, 399
- Szczepanski Colour Photography, 388, 423, 424, 438

- Table and Easel for Enlarging, *305
- Tablet (Glossary), xxxvii.
- Tachyscope, 664
- Takuquick Ferrottype Camera, *119
- Tanks, Dark-room, 268
- Tannic Acid (Glossary), xxxvii.

- Tannin (Glossary), xxxvii.
Tape Measure View Meter for Landscape Photography, 491
Tartaric Acid (Glossary), xxxvii.
Taylor's Anastigmat, 363
— Telephotography, 646
Teb Camera, 510
Telemeter (Glossary), xxxvii.
Telephoto Cornex Hand Camera, *508
— Lens (Glossary), xxxviii., *569, 370, 646—652
— Adon, 650
— Advantages of, 646, 647
— Angle of View in, 649
— Aperture of, 649, 650
— Attachments for, *650, 651
— Barlow, 646
— Beck Multiflex, 650
— Beck-Steinheil, 650
— Circle of Illumination, 649
— Composition of, 648
— Constructing Simple, 651
— Dallmeyer, *646, *650
— Duboscq, 646
— Equality of Illumination, 649
— Goerz, 650
— History of, 646
— Low-power, 640
— Mlethe, 646
— Optical Centre in, 648
— Principles of, 647, 648
— Steinheil, 646
— Stopping Down in, 650
— Variable Foci of, 648, 649
Telephotography (Glossary), xxxviii., 646—652
— Application of, 652
— Instantaneous, 651, 652
— Apparatus for, 651
— Tripod for, *651
— Porro and, 646
— Traill Taylor and, 646
— Von Rohr and, 646
Telescope for Astronomical Photography, *594—596
— Attaching Spectroscope to, 604
— Carrier for Spectrometer, 581
— Cassegrain's, *596
— Crossley Reflecting, 611
— Direction of, 597—599
— Eyepiece, Ramsden's, 594, 595
— Gregory's, *596
— Herschel's, *596
— Newton's, *596
— for Solar Observation, 601
— Spectrometer, 585
Tella Camera, 509
Temporary Support (see Carbon Process)
Tennant's Astronomical Photographs, 602
Ten-per-cent. Solution (Glossary), xxxviii., 270, 271
Tentative Development (Glossary), xxxviii.
Terebenthine or Turpentine (Glossary), xxxviii.
Terebine or Turpentine (Glossary), xxxviii.
Terra Rosa, 352
Tessar (Glossary), xxxviii.
Test Paper (Glossary), xxxviii.
Thermometric Rules, 715
Thiocarbamide (Glossary), xxxviii.
— Toning Bath, 247
Thiosinamine (Glossary), xxxviii.
Thio-urea or Thiocarbamide (Glossary), xxxviii.
Thomson's Rules for Pinhole Photography, 298
Thornton-Pickard Automan, 509
— Focal Plane Shutter, 641
Three-colour Half-tone Work, 703
— Photo-ceramics, 657
Three-colour Photography (Glossary), xxxviii. (see also Colour Photography)
— Photo-mechanical Work, 436—438
Tiles, Coating, with Collodion, 655
Tilting Board (Glossary), xxxviii., *54
— Stand for Monumental Work, *588
Time Development (see Factorial Development)
— Exposures (Glossary), xxxviii.
— and Light, Unity of, 415, 416
Tin, Black for, 714
Tinting Prints with Dyes, 351
Tinting Lantern Slide, 322
— Prints, 592, 593
Todd-Forret Magnesium Lamp for Portraiture, 476
Tone (Glossary), xxxviii.
— Influence of Printing on, 240
— Values (Glossary), xxxviii.
Tones, Black, Formula for, 251
Toning Action of Gold, 239
— Platinum, 239
— Albumenised Paper, 249, 250
— Alum Bath before, 242
— Bath (Glossary), xxxviii.
— Acetate of Soda, 246, 250
— for Albumenised Paper, 249
— Bicarbonate of Soda, 246
— and Acetate of Soda, 246, 247
— Chloride of Lime and Chaik, 247
— Compound Concentrated, 247
— Concentrated, 250
— Sulphocyanide, 246
— Formate of Soda, 247
— Gold Combined, 252
— Dilution of, 245
— Preparing, 245, 246
— Temperature of, 245
— Haddon's Formula for, 249
— Making-up, 248
— Phosphate of Soda, 247
— for Plain Salted Paper, 250
— Platinum, 248
— Combined, 252
— Sulphocyanide, 244
— Chemical Reactions of, 244
— Thiocarbamide, 247
— Tungstate of Soda, 247
— Treatment of Old, 676
— Black Spots caused by, 253
— Causes of Failure in, 257
— Chemistry of, 405
— Colours Available for, 240
— Double, 258
— Faults in, 258
— Finishing, 252
— First Lesson in, 22
— and Fixing Bath Combined, 251
— Gold, 405
— for Collodio-chloride Papers, 245
— P.O.P., 245
— with Gold and Platinum, 239—258
— Gold-uranium, 256
— Hardening Bath before, 242
— Influence of Negative on, 240
— Lead, 405
— Light for, 241
— Matt Paper, 249
— Operation of, *245, 244
— Palladium, 256
— Platinum, 248, 405
— Rinsing before, 252
— Stains in, 257
— Solution, 21
Toning, Theory of, 239, 240
— Time of, 245
— Unsuccessful, 257
— Uranium (Glossary), xxxix., 405
— Varying Amount of Gold in, 245
— Washing Prints before, 241, 242, 252
Torpedo Boat, Speed of, 105
Touches used in Retouching, 149
Tracing Point, Engraver's, *279
Transfer, Developing, for Photolithography, 684
— Paper (see Carbon Process)
— Photo-litho, 683, 684
Transferotype (Glossary), xxxviii.
Transferring Film in Photo-ceramics, 655, 656
Transfers (Glossary), xxxviii.
Transmitter, Brown's, *619
Transparency (Glossary), xxxviii.
— Carbon, 197
— Stereoscopic, Printing Frame for, *625, 626
Transposition in Stereoscapy, 617, 625
Tray, Stereoscopic, *618
Trebble Photographs, 716
Tri-amido-phenol Developer, 399
Tribasic Phosphate of Soda (Glossary), xxxvi.
Trichromatic Photography (Glossary), xxxviii., 425
— Applied to Microscope Work, 546, 547
Trihydroxybenzene (Glossary), xxxiii.
Trimming (Glossary), xxxviii.
— Cardboard Angles for, *279
— Circular Prints, *276
— Half-tone Blocks, *699
— Oval Prints, *276
— Prints, *275—278
— Rules for, 278
Trimming-glasses, *276, 277
— Testing, 276
Trimming-machines, *277
Triplet (Glossary), xxxviii.
Tripod (Glossary), xxxviii.
— for Instantaneous Telephotography, *631
— Screw (Glossary), xxxviii.
— Stand, Care of, 28
— for Interior Photography, 58
— Perfecto, *501
Trotting Horse, Speed of, 105
Trough, Etching, 697
Tyhorn's Stereoscapy, 622
Tubes, Crookes', 706
— Focus, 706
— Geissler, 706
— Vacuum, Exhausting, 707
Tungstate of Soda Toning Bath, 24
— Sodium (Glossary), xxxvi.
Turmeric (Glossary), xxxviii.
— Paper (Glossary), xxxviii.
Turnbull's Blue, 205
Turner's Stereo-photomicrography, *547
Turntable (Glossary), xxxviii.
Turpentine (Glossary), xxxviii.
Twin Lens Camera (Glossary), xxxviii.
Tyma Developing Trough, *129

U

- Ultra-violet Light (Glossary), xxxviii.
Unal, a form of Rodinal, 112
Unar Lens (Glossary), xxxviii.
Under-exposure (Glossary), xxxviii.
— Effect of Intensification (see Plate 5, facing p. 65)
— Evidence of, 114

Under-exposure, Treatment of, 115
 Underwood Foldette Camera, 509, 510
 Uniform Standard System (Glossary), xxxviii., xxxix.
 Universal Hand Camera, 507
 — Orthostigmat Lens, *567
 — Stereoscopic Transposer, *625
 Unofocal Lens (Glossary), xxxix., *574
 Uranic Salts, Action of Light on, 392
 Uranium (Glossary), xxxix.
 — Fluoride Screens, 704
 — Intensifier, 134, 135, 405
 — Nitrate (Glossary), xxxix.
 — Printing (Glossary), xxxix.
 — Process for Bromide Prints, 236
 — Recovery of, 676
 — Toning (Glossary), xxxix., 405
 U.S. System (Glossary), xxxvii., xxxix.

V

Vacuum, Crookes on the, 707
 — Tubes, Crookes', 706
 — —, Exhausting, 707
 — —, Focus, 706
 — —, Geissler, 706
 Valenta and Intensification, 405
 — — Three-colour Work, 437
 Valenta's Emulsion for Colour Process, 422
 Vanadium Chloride (Glossary), xxxix.
 — Printing (Glossary), xxxix.
 Varnish (Glossary), xxxix.
 — for Negatives, 152
 Varnishing after Painting, *349
 — Negatives, 151, 152
 — —, Dangers of, 152
 — —, Method of, 152
 — —, Reasons for, 151
 Veneer Mounts, 274
 Venetian Red, 352
 Ventilation of Dark-room, 262
 — — Studio, 471
 Verant, Dr. von Rohr's, 630
 Verascope, *505
 Verdigris, 352
 Vermillion, 352
 Verona Brown, 352
 Vidal and Three-colour Work, 437
 View Points, Adjusting for Stereoscopes, *620, 621
 View-finders (Glossary), xxxix., *59
 —, Direct-vision (Glossary), xix.
 — for Landscape Photography, *492, 493
 —, Testing, 493
 Viewing Devices, Stereoscopic, *626
 View-meter (Glossary), xxxix.
 Vignetter, Adjusting, 155
 —, Cardboard, *155
 —, Holt's, 699
 —, Iris, *153
 —, Salmon's, *155
 —, Wooden, *154
 —, Zinc, 153, *154
 Vignettes, Border, 158
 —, Cloud, 157
 —, India-tint, *156
 —, Medallion, 158
 Vignetting (Glossary), xxxix., 152
 —, Bottle Jack for, *156
 —, in Bromide Printing, 227, 228
 —, through the Camera, 156, 157
 —, in Enlarging, 313
 —, Glass (Glossary), xxxix.
 —, Flashed Glass for, *153
 —, Methods of, 153
 —, Mount Effect in, 157
 Violet, Permanent, 352

Viridian, 352
 Vision, Colour, Theory of, 424
 — —, Persistence of, 664
 Vitagraph, Clement and Gilmer, 671
 Vitriifiable Colours for Photoceramies, 654
 Vogel, W. H., and Optical Sensitizers, 388
 — — and Orthochromatism, 443
 — — on Sub-salts, 408
 Vogel's Discoveries in Colour Sensitiveness, etc., 390, 391, 441
 Voigtlander, F., 362
 — Brunswick Hand Camera, *507
 — Collinear Lens, 374
 — Euryscope, *553
 — Favourite Hand Camera, *507
 — Heliar Hand Camera, 507
 — Portrait Lens, *365
 Von Bibra on Sub-salts, 407, 408
 Von Hoegh, 365
 Von Rohr's Telephotography, 646
 Vril Camera, 509

W

Warnerke's Measurement in Photomicrography, 518, *519
 — Sensitometer Screen, 412
 — System of Determining Plate Speeds, 412
 Warwick Bioscope, 671
 Wash Brush for Colours, *342
 Washers, Mechanical, *255, *256, *314
 Washing, Explained, 10
 — Plates after Development, 114
 — of Prints, Final, 255
 Washings, Silver, 674
 Water (Glossary), xxxix.
 — Bath Apparatus for Collo-type Sensitizer, *679
 Water-colours, 399
 —, Brushes for, *339
 Water-glass, or Silicate of Soda (Glossary), xxxvi.
 Waterhouse Diaphragms (Glossary), xxxix., 31
 — on Latent Image, 410
 — Stops, 30, 32
 — on Sub-salts, 403
 Waterhouse's Experiments, 388, 389
 Water-jacket, Emulsion, *65, *66
 Water-lens (Glossary), xxxix.
 Watkins' Bee Meter, 102
 — — —, Stops used with, 102
 — Exposure Formula, 102
 — — Meter for Indoor Work, 102
 — Factorial Development, 115—117
 — Print Meter, 190
 — Standard Exposure Meter, 100—102
 — Table of Pinhole Diameters, 295
 Watson's Condenser for Microscope, *532
 — Fram Microscope, *523
 — Illuminator for Photomicrography, *546
 — Motorgraph, 671
 — Oxycalcium Apparatus, *515
 — Process Camera, *890
 — Stereoscopic Binocular Camera, 505
 Wax (Glossary), xxxix.
 Wedgwood, Thomas, 3
 Wedgwood's Method of Printing Out, 163
 Weighing in Plate Making, 61
 Weights and Measures, 718
 Wellington's Silver Intensifier, 135, 136
 Wet Collodion Plates, Intensifying, 136, 137

Wet Collodion Process (Glossary), xxxix., *73—79
 — — —, Apparatus Required for, 75
 — — —, Enlarging Negatives by, 318
 — — —, Plates (Glossary), xxxix., 118
 — — —, Developer for, 118
 — — —, on the Sub-salt Theory, 407
 Wheat-stone Stereoscope, 626, 627
 Wheel Diaphragm (see Rotating Stops)
 — — of Life, 664
 Wheeler's Metzograph Screen, 686
 Whirler, Plate, 272
 — — for Coating Plates, 696
 White, Permanent, 352
 White's Posing Chair for Portraiture, *481
 Whole Plate (Glossary), xxxix.
 Wide-angle Lens (Glossary), xxxix.
 Wiener on Colour Photography, 421
 Williams, Collingwood; Method of Gauging Light Intensity, 519
 Willis's Platinotype Process, 205
 Wilson's Stereoscopic Projection, 632, 635
 Wilmshurst Induction Machine, *569, 706
 Winter Work, 510
 Wizard Hand Camera, *509
 Wöhler and Carbon Compounds, 454
 — on Sub-salts, 407
 Wollaston and Fraunhofer Lines, 570
 Woodburytype (Glossary), xxxix.
 — — Process, 702
 — —, Development in, 702
 — —, Exposure for, 702
 — —, Gelatine Reliefs from Dry Plates for, 703
 — —, Obtaining Metal Mould for, 702
 Wood's Diffraction Grating Process, 432—434
 Woodward on Illuminants and Exposure for Photomicrography, 513
 Working-up (Glossary), xl.
 — — Enlargements with Crayons, 331, 332
 — — Prints, 325—336
 Wortley's Gelatine Emulsion, 6
 Wray Platysigmat Lens, 374
 Wynne's Infallible Exposure-Meter, *103
 — — Print Meter, 189

X

Xit Camera, 509
 X-ray Photography (Glossary), xl., *704—709
 — Tube, Fluorescence of, 707

Y

Yellow Light, Developing Power of, 390
 — —, Permanent, 352
 — — Screen (see Isochromatic Screen)
 — — Stain (Glossary), xl
 Young's Colour Vision Theory, 424

Z

Zambex Hand Camera, 509
 Zeiss Apochromatic Objectives, 527

- Zeiss Camera for Photomicro-
 graphy, *540, 541
 — Illuminator for Photomicro-
 graphy, *540, 541
 — Lenses, 363
 — Photomicrographic Appar-
 atus, *515, 516
 — Stand for Photomicrography,
 *523
- Zenker on Colour Photography, 421
- Zinc (Glossary), xl.
 —, Black for, 714
 —, Cutting-shapes, *277
 —, Method of Recovering Silver,
 676, 677
 —, Plates, Etching, *697
 —, Transferring Photo-litho Print
 to, 685
- Zinc Vignetter, 153, *154
- Zincography (Glossary), xl.
 — (See Photo-zincography)
- Zinc-white, 352
- Zirconia Light employed in Ph
 micrography, 518
- Zoetrope, 664
 —, Adaptation, Anschu., 664
 —, Ducos du Hauron and, 664

BOSTON PUBLIC LIBRARY



3 9999 05493 485 4

Boston Public Library
Central Library, Copley Square

Division of
Reference and Research Services

The Date Due Card in the pocket indicates the date on or before which this book should be returned to the Library.

Please do not remove cards from this pocket.

