

BRAINS OF RATS AND MEN  
BY  
C. JUDSON HERRICK



MBL/WHOI



0 0301 0020315 4

*with compliments of  
Jackson H. Smith*



# BRAINS OF RATS AND MEN

THE UNIVERSITY OF CHICAGO PRESS  
CHICAGO, ILLINOIS

—  
THE BAKER & TAYLOR COMPANY  
NEW YORK

THE MACMILLAN COMPANY OF CANADA, LIMITED  
TORONTO

THE CAMBRIDGE UNIVERSITY PRESS  
LONDON

THE MARUZEN-KABUSHIKI-KAISHA  
TOKYO, OSAKA, KYOTO, FUKUOKA, SENDAI

THE COMMERCIAL PRESS, LIMITED  
SHANGHAI

4 1/2

# BRAINS OF RATS AND MEN

A SURVEY OF  
THE ORIGIN AND BIOLOGICAL SIGNIFICANCE  
OF THE CEREBRAL CORTEX

BY

C. JUDSON HERRICK

PROFESSOR OF NEUROLOGY, THE UNIVERSITY OF CHICAGO



THE UNIVERSITY OF CHICAGO PRESS  
CHICAGO · ILLINOIS

COPYRIGHT 1926 BY  
THE UNIVERSITY OF CHICAGO

---

All Rights Reserved

---

Published August 1926

Composed and Printed By  
The University of Chicago Press  
Chicago, Illinois, U.S.A.



TO THE MEMORY OF  
CLARENCE LUTHER HERRICK

MY ELDER BROTHER, MY FIRST TEACHER OF SCIENCE  
AND THE GUIDE AND INSPIRATION OF ALL  
MY SUBSEQUENT ENDEAVORS



*One does not get nearer to the ideal state any the more quickly by trying to force the shortest cut to the goal of strictest unity, by proclaiming meagre beginnings as the final principles, and by owing to the facts what is saved on the theories.*

—W. KÖHLER



## PREFACE

**I**N the summer of 1924 I was invited to deliver a course of lectures at the University of California on "Mechanisms of Control of Animal Behavior." Some of the material there presented is incorporated in this volume. Since that time in attempting to formulate more critically the probable history of the elaboration of cortical functions I naturally restudied Lashley's fundamental experiments on the learning processes of rats. The result was that my entire treatment of cortical function in lower mammals was recast. This volume is the direct outgrowth of this re-survey of the problem of the cerebral cortex.

There are two species of mammals whose behavior has been more intensively studied under conditions of laboratory control than any others. These are rats and men. Since one of these stands near the bottom of the mammalian scale and the other represents the culmination of cortical development, it seems appropriate that our discussion should center about these species and the problems opened up by the facts available regarding their nervous systems in relation to their behavior patterns.

I have appropriated freely facts and illustrations from the works of others, to whom I wish here to make general acknowledgment in addition to the special references scattered throughout the text. To the courtesy of Henry Holt and Company we are

indebted for permission to reproduce Figures 8, 25, and 28; to W. B. Saunders Company for Figures 3 and 4; and to the Field Museum of Natural History for Figures 32 and 33. Parts of the text have been read by several of my colleagues, from whom many valuable suggestions have been received. Others, too numerous to mention, have given less direct, though not less valuable, assistance.

I am especially indebted to Professor Lashley, who has read parts of the text; and in numerous conferences he has generously given me the benefit of his wide experience and critical thinking. While the conclusions which we have reached are not in perfect accord, we agree that this arises largely from difference in point of view and emphasis. But not wholly so; there are some questions that seem fundamental which I believe cannot be resolved by the oversimplified formulations now current in the field of "objective psychology."

These problems are here approached from the biological side and with biological technique. The aim is to limit the discussion to that field which can properly be cultivated with the methods of natural science, though I would extend the confines of this field much further than many of my colleagues seem to consider permissible.

In particular, the belief that mind or consciousness as introspectively experienced is a natural phenomenon which cannot be neglected in a total view of

human behavior demands that this phenomenon be examined by the usual method of natural science and articulated in some organic way with the vital processes in their entirety. The evidence is biologically adequate that mind (awareness) as we know it phenomenally is a function of a particular configuration of bodily organs. Without attempting to explore the philosophic implications of this simple datum of experience, we shall find that its biological implications are far reaching.

In brief, the whole-hearted acceptance of this datum as a proximate (not ultimate) basis for further scientific exploration of human conduct reveals the common ground upon which objective psychology and introspective psychology may co-operate harmoniously without sacrifice of sound scientific method or of those distinctive technical procedures which each of these sciences has hitherto so fruitfully employed.

In conclusion, a few words in amplification of the dedication of this volume. My elder brother was one of the few survivors of the old school of all-'round naturalists, and yet so modern in his interests, his viewpoints, and his methods as to rank among the pioneers of the new school. An experienced field naturalist, well trained in the most advanced laboratory methods of his time, a philosopher of wide reading and profound thinking, an unsurpassed teacher, first attached to the Geological and Natural History Survey of Minnesota, sometime professor in Denison

University, the University of Cincinnati, the University of Chicago, later president of the University of New Mexico, his encyclopedic knowledge, intellectual honesty, and personal magnetism have left their impress upon American science for all time. His untimely death in 1904 at the age of forty-six left all of his enterprises incomplete, but the influence of his personality still lives.

Shortly before an acute attack of pulmonary tuberculosis in 1894 (from which he never recovered) my brother laid out a comprehensive program of research in comparative neurology, planning to devote himself to the study of animal behavior in its genetic aspects, in the hope that I would carry on parallel morphological studies upon the nervous systems of the animals under investigation. His part of this program has since been ably prosecuted by others. My own anatomical work has been guided throughout by the motives implanted by my brother's insight and tutelage, to which in no small measure the conclusions presented in this volume owe their parentage.

C. JUDSON HERRICK

CHICAGO, ILL.

December 21, 1925



# CONTENTS

CHAPTER	PAGE
I. WHAT WE DO WITH OUR BRAINS . . . . .	1
II. THE PROBLEM OF THE CEREBRAL CORTEX . . . . .	23
III. REFLEX ACTION AND CONDITIONED ACTION . . . . .	38
IV. THE ORIGINS OF THE CEREBRAL CORTEX . . . . .	68
V. CEREBRAL CORTEX AND CORPUS STRIATUM . . . . .	92
VI. CORPUS STRIATUM OF MAMMALS . . . . .	112
VII. THE THALAMUS . . . . .	128
VIII. THE CEREBRAL HEMISPHERES . . . . .	148
IX. HOW DO RATS LEARN? . . . . .	166
X. MECHANISMS OF LEARNING IN THE RAT . . . . .	178
XI. LOCALIZATION OF THE LEARNING PROCESS IN THE CEREBRAL CORTEX OF THE RAT . . . . .	193
XII. THE FRONTAL LOBES . . . . .	220
XIII. THE ASSOCIATION CENTERS . . . . .	234
XIV. SUMMARY OF CORTICAL EVOLUTION . . . . .	256
XV. THE SUBCONSCIOUS . . . . .	268
XVI. CONSCIOUSNESS AS A VITAL FUNCTION . . . . .	285
XVII. VITAL RESERVES . . . . .	312
XVIII. THE SOURCES AND ENDS OF HUMAN EFFORT . . . . .	327
XIX. RATS AND MEN . . . . .	347
BIBLIOGRAPHY . . . . .	366
INDEX . . . . .	379

23942



## CHAPTER I

### WHAT WE DO WITH OUR BRAINS

*The scientific study of man is the most difficult of all branches of knowledge.*

—OLIVER WENDELL HOLMES

**I**N the earliest days of which we have record this question seems not to have arisen. In very ancient times there was current an idea (confirmed by modern science) that the emotions are intimately related with certain viscera. The “yearning of the bowels” expresses sound physiology. Even today the tender sentiments are localized in the heart, as every anniversary of St. Valentine’s Day reminds us, and in Solomon’s time this organ was also regarded as the seat of courage and intellect. “For as he thinketh in his heart, so is he.”

These ancient dogmas took no account of the brain, whose part in the vital economy was an unsolved riddle. Though Hippocrates, Plato, and other Greeks approached the truth, so great a naturalist as Aristotle assigned to the brain the incidental function of serving as a sort of refrigerating plant to cool the too-fervid animal spirits.

History, the venerable old dame, like other elderly people is said to be inclined to repetition, and in quite recent times some opinions about the functions of the brain that are strongly reminiscent of the

Aristotelian position have attained great popularity in certain scientific circles. In a short excursion into this very obscure and recondite field we shall examine a few details of the structure and probable working of the brain which may help us to put these functions into their proper setting as a part of the general process of living. This implies that we shall approach the problem from the biological side, and that we shall endeavor not to carry our speculations beyond the realm of natural laws.

Early in the scientific study of nerves it was found that they are conductors of some sort. And today there has been accumulated an enormous mass of accurate information regarding the lines of transmission of nervous impulses within the brain and throughout the body as a whole.

The known complexity of the lines of nervous conduction within even so simple a brain as that of a frog, if mapped out in detail, would make the wiring chart of the largest electrically driven factory look as simple as a county-road map. And if we turn to the human brain it is no exaggeration to say that a complete map of every circuit in all the telegraph and telephone lines of the North American continent would be incomparably simpler than such a chart of the nervous circuits of which we already have some knowledge. And the half of our nervous equipment has never been told.

Recently, in conversation with a mathematician,

we were commenting on some of the stupendous numbers employed by the astronomers in measuring the distances of the stars. The unit of measure here is the light-year, that is, the distance traversed by light in a year—about six million million miles, or  $6 \times 10^{12}$ . The nearest fixed star whose distance has been measured, alpha Centauri, is about four light-years from the earth, and it has recently been estimated that the giant nebula Andromeda is about a million light-years away. Expressed in miles, the distance to the star alpha Centauri is about  $24 \times 10^{12}$  and to Andromeda about  $6 \times 10^{18}$ .

Turning now to smaller things, the diameters of the atoms have been computed. My mathematical friend tells me that in a cubic centimeter of water the number of atoms is  $10^{24}$ . Extending the computation, the solar system contains  $10^{56}$  atoms and the entire visible sidereal universe contains about  $10^{66}$  atoms.

Such numbers stun the imagination of the non-mathematical mind. But a little computation shows that the known complexity of the nervous connections of the human body present possibilities of associational combinations of the nerve cells among themselves that run into numbers of even greater orders of magnitude.

The total number of cells in the human body has been estimated by Francke to be about  $2.65 \times 10^{13}$ , a number which is probably too small. Of this total, the larger proportion ( $2.25 \times 10^{13}$ ) are blood corpuscles

which float freely in the blood stream. Donaldson estimates that there are about twelve thousand million ( $12 \times 10^9$ ) nerve cells or neurons in the human brain, and more than half of these, or ninety-two hundred million ( $9.2 \times 10^9$ ), are in the cerebral cortex (Thompson, 1899).

Each blood corpuscle is practically an independent organism. It may do its work independently of any of the other cells of the body. But the most characteristic thing about the nerve cells, with the related nerve fibers, is that they are conductors; their most significant function is to connect various parts of the body so that these parts may co-operate in the performance of some activity. Each of these neurons has fibrous outgrowths which may connect directly or indirectly with many hundreds of other neurons. This is particularly true of the nerve cells of the cerebral cortex.

Two million blood corpuscles may do twice as much work as one million; but two million cortical neurons are not twice as efficient as one million such elements, for the functional value of any cortical structure is measured by the complexity of the interconnections of its neurons one with another, not directly by the number of these elements. Two million cortical neurons may provide the mechanism of behavior patterns which are incomparably more complex than those which are possible with one million such cells.

If a million cortical nerve cells were connected one with another in groups of only two neurons each in all possible combinations, the number of different patterns of interneuronic connection thus provided would be expressed by  $10^{2,783,000}$ . This, of course, is not the actual structure, as we shall see; but the illustration may serve to impress upon us the inconceivable complexity of the interconnections of the ninety-two hundred million nerve cells known to exist in the cerebral cortex.

Every neuron of the cerebral cortex is enmeshed in a tangle of very fine nerve fibers of great complexity, some of which come from very remote parts. It is probably safe to say that the majority of the cortical neurons are directly or indirectly connected with every cortical field. This is the anatomical basis of cortical associational processes. The interconnections of these associational fibers form an anatomical mechanism which permits, during a train of cortical associations, numbers of different functional combinations of cortical neurons that far surpass any figures ever suggested by the astronomers in measuring the distances of stars. And in the cortical association centers it is the capacity for making this sort of combination and recombination of the nervous elements that determines the practical value of the system.

In the retina of each eye it has been estimated by Krause that there are about one hundred and thirty-

seven million rods and cones. When the visual area of the cerebral cortex is activated following the stimulation of the retina by some particular field of view, it is safe to say that at least a million cortical nerve cells are directly stimulated by the nervous impulses which discharge into this cortex from the optic thalamus. These million cells activate other millions, and so on in indefinite series, and the aggregate of the connections actually made in any extended associational process is evidently an enormous number. This may be illustrated by some further computations.

The known arrangement of cortical intercellular connections may be crudely and very conservatively expressed by saying that each of the million cells which we suppose to be stimulated in the visual area is directly connected with ten others, each of these with ten others, and so on in series. A diagram of this simple geometrical progression would look like a family tree in which each of a million families has ten children, each of these ten, and so on. If we start with the excitation of a million cortical cells, each of these nervous impulses is multiplied tenfold at every step in the ramification of the nerve fibers, and at the fourth member of this series (the fourth generation of our genealogical tree) more than the total of nine thousand million cortical cells would be involved.

But the structure is not really so simple as this. The arrangement of cortical associational connections



is not that of a simple geometric progression, for the lines of connection cross in all imaginable patterns and any one of the nine thousand million cortical neurons may be represented in very many of the possible associational patterns. To recur to our analogy of a genealogical tree of a million families, the family lines do not run on quite independently of one another, but by intermarriage each family tree is related with all of the others.

Upon activation of the visual cortical field by the sight of the litter of the day's work upon my study table, associational processes are immediately set up within the cortex and each of the million excited cells of the visual area activates at least ten others, and each of these, in turn, ten others, and again on and on as long as the cortical process continues. And any particular cortical neuron may be repeatedly activated in different associational patterns, and the range of variety of these possible combinations cannot be exactly formulated in mathematical terms. For practical purposes it may be regarded as approaching infinity.

On the basis of the known structure of the cortex, the following computation may be regarded as a conservative statement of the number of intercellular connections that are anatomically present and available for use in a short series of cortical associational processes. Starting again with a million ( $10^6$ ) cortical neurons of the visual area simultaneously ex-

cited by some retinal image, each of these certainly activates at least ten others ( $10^7$ ), and each of these in turn ten others ( $10^8$ ). From each of these last neurons associational fibers go out that may reach the extreme dimensions of the cortex, and at this stage of the process the  $10^8$  neurons in actual function may act upon a considerable part of the entire cerebral cortex, some parts being intensely activated and other parts being so slightly affected as not to reach the threshold of stimulation.

But the associational process has just begun. From each of these foci of cortical activity, lines of nervous conduction irradiate in definite patterns depending on the particular trains of association that are set up, and these lines of transmission may be activated in momentarily changing patterns of unlimited complexity. If for simplicity of computation we limit ourselves to one million of the  $10^8$  neurons already activated in the process, and if we assume that these may be recombined among themselves in all theoretically possible patterns, the total number of such connections would far exceed the  $10^{2,783,000}$  already mentioned as the theoretically possible combinations in groups of two only. Not all of these theoretic combinations are actually present anatomically, but a large proportion of them certainly are structurally there.

Of course, in any one series of cortical associations only a minute fraction of the anatomically present

connections are really in action, but as the patterns of cortical associations change from moment to moment the total of anatomically present intercellular connections that may be activated is so large a number that it seems futile to attempt to express it in figures. These are the possible combinations, not those actually working.

During a few minutes of intense cortical activity the number of interneuronic connections actually made (counting also those that are activated more than once in different associational patterns) may well be as great as the total number of atoms in the solar system. Certainly not all anatomically present connections of nervous elements are ever used, but the *potentialities* of diversity of cortical associational combinations are practically unlimited and the personal experience of the individual is probably an important factor in determining which of these possibilities will be actually realized.

The efficiency of the cortex, what practical use we can make of these potential intercellular associational connections, seems to depend in the first place upon the number and character of the associational patterns that are laid down as enduring structural records of past experience (that is, the number and character of our memory vestiges—what we have learned), and in the second place upon the facility with which these memory patterns can be reactivated in useful combinations (that is, the extent to which

knowledge previously acquired can be fitted into new situations).

These cortical potentialities form the organic background of those reserves of power and capacity and those latent possibilities of education and constructive thinking that are present in all of us and yet too often never come to practical expression, as James has so graphically portrayed in his discussion of "The Energies of Men" (1907).

All this means that when the auditory cortical field is activated—say by the sound of the dinner bell—or the visual cortical field is activated—say by the sight of the table spread in the dining-room—the associational fibers which reach out from these cortical fields may in turn activate remote parts of the cortex in diverse patterns in unimaginable complexity, depending upon the innate architecture of the cortex and the past experience of the individual. Specific memory vestiges of previous related experiences are reactivated, and each of these irradiated nervous excitations implies the quickening into functional activity of many millions of nerve cells related to one another in some definite structural pattern.

As the hostess gives her dining table a final appraising glance, many things flash through her mind. Is the service properly appointed? Are the courses ready in the kitchen in proper sequence? Has the seating of the guests been tactfully planned? Mrs. Wilbur's new yellow gown will clash with her neigh-

bor's softer colors, and a reseating is imperative. Has the choleric Colonel Blair composed his quarrel with Mr. Nesbit? All this and more is done during the flash of an eye, but in that tense moment we may be sure that neurons to the number of countless millions are all very busy, transmitting their messages hither and yon throughout the entire cortex as now one then another associational pattern is momentarily activated.

The simplified neurologic schemata which we use as pedagogic devices are necessary instruments for unlocking those doors of the student's mind which lead into the more recondite secrets of nervous organization. But having opened the door in this way, the key should be laid aside and not regarded as even an adequate symbol of the actual organization, as is so often done in both clinical and psychological practice. The inconceivable intricacy of the structural connections within the brain is generally underestimated even by neurologists. And to speak of memories or any other unitary cortical functions as localized in some particular cells or in some small cortical areas is to talk neurologic nonsense.

The known complexity of the brain, and especially of its cerebral cortex which fills the massive dome of the skull, is adequate for any theoretic explanation of cerebral function whatsoever. There is no dearth of mechanism. The problem is, What do these complicated webs of interconnected nerve cells and fibers

actually do? What part do they play in the practical problems of getting on in the world?

One phase of this problem is satisfactorily answered. Some of these nerve fibers are the annunciator wires that run from the doorways at the surface of the body. A beam of sunlight falls upon the body. There are only two doors by which it may enter. If it enters the eye, here it presses a button that activates a circuit in the optic nerve, the signal is registered upon a central switchboard, and we see the light. Or if it falls upon the skin, another button is pressed and we feel the genial warmth. Similarly, the ear alone can announce the impact of a sound wave and the nose the odor of my morning coffee.

The nerves and their sensory end-organs are analyzers, through whose action alone we are able to adjust ourselves to what is going on about us. The actual adjustment is effected by another set of nervous circuits which go out to the appropriate muscles. But what determines which muscles will respond to any particular sensory excitation—whether I drink the coffee or give it to the goldfish?

The answer to this question is to be sought in the central switchboard mechanisms of the brain. And for this answer we are still searching. We know that the burned child dreads the fire, and instead of reaching out again to grasp the pretty flame, he shrinks in terror. But we do not yet know how he does it. We believe also that this particular switch-

board system is automatic. There is no scientific evidence of any little deity who presides at this "central" and receives the incoming calls and plugs them into appropriate outbound circuits with more or less intelligence, more or less accuracy, more or less affability.

This is our scheme of reflex action and of simple learning by trial-and-error, as mechanically determined as an automatic telephone exchange. It is well authenticated. We do not know as much as we would like (and hope for) about how the machine works, but that it is a strictly automatic action there is general agreement.

Now, these reflex units can be combined in various degrees of complexity, and it is a popular belief nowadays that all animal behavior and all human conduct are regulated thus mechanistically by successive hierarchies of reflex circuits. There is no doubt in the minds of most qualified students of the question that this mechanistic conception of reflex is true. But how far can we extend it, and is it an adequate basis for a true understanding of all human behavior? We are no nearer to a consensus of opinion on these questions today than were the contemporaries of Solomon when he wrote his Book of Proverbs.

One extreme is typified by the president of a college to whom, as a youthful enthusiast, I went many years ago with the suggestion that perhaps it would be helpful if I were to offer a course on the

functions of the brain parallel with his own lectures on psychology. "Young man," he said, "the brain has no more to do with thinking than the cabbage heads in my garden." I suppressed the obvious retort, that perhaps that is true of some brains—and I gave the course to my students of biology *before* they reached the president's lectures on psychology.

The other extreme is represented by the radical behaviorists who have developed a so-called "objective psychology." Pushing the mechanistic physiology to its limit, they maintain that, since everything that the body does is the sum of the functions of its organs and since these functions are all connected in causally determined chains, we need to study only objective behavior and its mechanisms to gain a complete knowledge of man. Subjective experience does not seem to fit into this simplified scheme of things and so, it is argued, it can be neglected in a scientific analysis of human life. One ardent member of this school says that the term "emotion" should be dropped from our vocabulary, for all that we mean by the word is visceral behavior.

Thus the entire brain becomes a reflex machine, and (as Canon Kingsley asks in that inimitable biological classic, *The Water Babies*) what, then, would become of the faith, hope, and charity of immortal millions?

Since behavior (according to this school) is all of life that we can study and evaluate scientifically, the



organs of overt behavior—viscera, muscles, larynx, etc.—bulk larger in the writings of some of these new psychologists than does the cerebral cortex, and we are back to about the same fundamental physiological point of view as that of King Solomon already quoted.

But are we scientifically justified in treating the conscious side of human life as a by-product, an epiphenomenon, or a parallel phenomenon that can be ignored in either a critical or a common-sense view of living? It is true that so far most philosophers and introspective psychologists have signally failed to knit their accounts of the conscious processes into the general scheme of life as the biologist must view it. This is probably due to preconceptions of some sort or other which are incompatible with a unified scientific treatment of the problem.

Let us start anew with a different set of preconceptions, with a working hypothesis which is mechanistic throughout and therefore presumably acceptable to those who follow rigorously the scientific method. In the past, consciousness has usually been treated as a thing apart, not causally related with bodily processes. This promptly leads off into mysticism where science cannot follow, for the scientific method of today postulates a single order of nature, a unitary cosmos, not a dualistic or pluralistic universe.

But consciousness is not mystical unless we choose

to make it so. And, in fact, all experience answers plainly and simply that our thinking and our doing are woven together in a single life, not a double life, and they do stand in cause-and-effect sequence.

Dewey somewhere comments on the impossible attempt to live in two unrelated worlds at once. That way madness lies. Just how consciousness knits in with my conduct, that is, what is the mechanism involved, I do not know. But only eyes blinded by prejudice can fail to recognize that it does so efficiently. The question before us is, Does it do so naturally or supernaturally, mystically? Let us follow the natural road as far as we can before turning aside into mysticism. And above all, let us inquire more deeply before we throw out of our scheme of living those higher thoughts, appreciations, aspirations, and idealizations that alone make life on the human plane worth while.

The biologist knows no disembodied functions. It is natural for him to say, "It is the function of muscles to contract and of the brain to think." And why not? The only kinds of minds of which we have first-hand experience are human minds. And so far as accurately controlled observations have thus far gone, the mental processes are not structural entities, the mind is not something static that can be detached from the body. The mind fatigues like other bodily functions, it is disordered by intoxications and by bodily derangements, and its activities

in turn cause other bodily acts. The evidence that mind is a function of brain (mind in the ordinary sense in which we use the term in science and in common life) is of exactly the same sort as the evidence that in birds flight is a function of wings, and to an unprejudiced observer it is quite as convincing.

This means, of course, that thinking is mechanistically determined, the same as flying and walking; and also that thinking is a true cause of subsequent events—not an epiphenomenon.<sup>1</sup> We do not know how the brain thinks, nor as much as we would like about how a muscle contracts; but this does not forbid accepting the evidence that these organs do perform these functions.

<sup>1</sup> The expression “mechanistic determinism” inevitably carries with it some metaphysical implications which we do not wish to discuss here. But to avoid misunderstanding it is necessary to point out at the start that our conception of determinism does not imply that the entire history of our cosmos was wrapped up in definitive form at its primordial origin. Cosmic evolution, like organic growth, is not a mere unfolding of what was already there; it is a creative process. New patterns are fabricated out of old materials by natural agencies. What is now has been determined in causal sequence. It is also a determining cause of what will be next.

In ordinary scientific usage the concepts of cause, mechanism and determinism are empirically formulated. A causal sequence implies an observed and verifiable uniformity of orderly progress of events. Each component of the causal sequence is a determining agent in the sense that the succeeding events would be different if it were absent. In this empirical sense it is necessary. A new causal factor enters at every change. Mechanistic determinism thus resolves itself into a progressive determining. Some implications of this naïve naturalistic way of looking at experience are elaborated in another work now in process of preparation.

If we look at the matter in this way, some very important consequences follow. If our thinking is recognized as an efficient cause of subsequent mental and physiological processes, clearly it influences not only behavior but also the stable personal organization that we call "disposition" and "character." To some extent, the practice of thinking, deciding, feeling, appreciating, and sympathizing molds the personality of the thinker. Presumably, the stable patterns of cortical association are changed by the performance of these acts just as on a lower plane muscles are changed by systematic exercises. There is thus a certain measure of internal control, through conscious effort, of the course of character-building as truly as there is an internal control in the course of habit formation (perhaps unconsciously) by trial-and-error. To this extent the person controls his own destiny, for human destiny is evaluated not merely by how long we live, but by how we live, what we get out of life for ourselves, and what we contribute to the world in which we live. These are the true measures of the worth of life.

Obviously, then, thinking, willing, loving, hating, joy and sorrow, are really parts of living on the biological plane, and we biologists and psychologists need not cut ourselves off from the rest of mankind (even academically) by refusing to recognize and employ these useful and on the whole rather pleasant vital processes in our business as professors of science. Indeed, we capitalize our ability to do so, for brain

power (as the man on the street correctly calls it) is the measure of the size of the pay check in the university as well as in the office and factory.

Some day we may be able to write chemical and energy equations to express the physical changes in my cerebral cortex while I solve a mathematical problem and to map the courses of all of the nervous currents which play back and forth in my brain; but even in advance of that distant day I go on adding the columns of my ledger or whatever else is necessary to strike a trial balance of my day's work at its close.

But this is not all. Human thinking employs language and other symbols, by the aid of which we generalize from our experience, discover laws of nature, and so prognosticate the future. What I do today I do in the light of its probable effect upon tomorrow. Foreknowledge of the probable consequences of my action becomes a causative factor in determining the present act. It is not that I foresee what I shall be compelled to do, but the prevision of the possible results of an action is a causative factor in deciding what I actually do now. The deliberate balancing of consequences of possible action in the light of general notions, laws of nature, and personal ideals seems to be a distinctive human capacity. We have no satisfactory evidence that any brute can perform this wonderful feat, and we have the best of evidence that in mankind this supernal achievement is a function of the cerebral cortex.

Here a very particular kind of mind, which is a

function of the distinctive human kind of cortical association centers, marks off human behavior from that of brutes—a distinction of far-reaching significance. For I can foresee the road which I expect to travel; I can prepare it in advance and so facilitate the going; and I can train myself in advance to endure the hardships of the journey.

The first two of these three sorts of foresight form the intellectual and material basis of human civilization; the third lies at the basis of self-culture, self-realization, and character-building through the fabrication of personal ideals. Meanwhile, the social factors have entered and the self is broadened to include in its interests the family, clan, state, and in the end (let us hope) the community of nations.

In answer to the question with which we started, we can now say that the human cerebral cortex is the specific organ of civilization, and whether this civilization is beneficent or malevolent is determined (in part) by the bodily organization of its component individuals, and in particular by their cortical organization. Foresight, purpose, and the ideals toward which we strive as individuals and as nations are functions of this same cortical gray matter. These are noble functions. And the nobility of man at his best inheres in his total organization; it is no detached aura to be laid aside like a Sabbath vesture when we turn to the routine of everyday living.

To say that the human cerebral cortex is the organ of civilization is to lay a very heavy burden on so small a mass of matter. One is reminded of Darwin's amazement that the wonderfully efficient and diversified behavior of an ant can be carried on with so small a brain, which is "not so large as the quarter of a small pin's head." The complexity of the human brain is as far beyond that of an ant as human conduct is higher than ant's behavior.

The individual human brain controls the individual's behavior, and when we say that the human cerebral cortex is the organ of civilization this does not mean that any single brain must perform the stupendous labor of keeping the wheels of civilization moving. But in a social organization every individual's behavior knits in with that of the others, and so his cerebral functions act in a social as well as a physico-chemical environment. And as his personal consciousness develops into a social consciousness the cortical mechanisms are correspondingly enlarged. The human cortex is twice as big and more than twice as intricate as that of an ape of equal body weight.

All higher symbolic thinking, all abstraction and ideation, use language symbolism as a necessary tool, and language is essentially a social function. The distinctively human type of cortical organization has therefore grown out of man's social relationships. It culminates in this same social sphere, as expressed

in co-operative effort, sympathy, altruism, and morality.

Every step in the process of fabrication of human culture has followed the preceding step in causal sequence; at no point have we left the wide realm of natural law; it is deterministic throughout. And we have found a place in our natural system for reflex, instinct, intelligence, will, emotion, sentiment, idealism, faith, hope, and charity—all in the frame of natural law. Some of these functions are characterized by awareness introspectively experienced while they are going on, without loss of their natural character.

These are functions of protoplasm which have arisen and survived because, like other stable patterns of living, they are good for us who live on the plane of human social organization. In biological terms, they are adaptive; they have survival value on this plane of living just as truly as greed, ferocity, and cunning have survival value on the ape-and-tiger plane.

The hereditary ape-and-tiger impulses are strong, and it is easy for us to revert to that plane. But the development of humanity during the eight or ten thousand years of which we have record has been along the lines of progressively more of the mental type of efficiency, and in the most recent phase of this history the alternative is put squarely before us—learn to co-operate with your neighbors (not fight them) or perish from off the earth.



## CHAPTER II

### THE PROBLEM OF THE CEREBRAL CORTEX

*Upon the equilibrium theory of consciousness it is not difficult to conceive that the tendency to coordinate and fuse various stimuli into one form of activity must be perpetually present, and as a matter of fact the most striking peculiarity of mental action is this same law of mental composition which finds its highest expression in what is called apperceptive action.*

—C. L. HERRICK

**H**AVING now indicated in a sketchy way the general point of view from which this inquiry takes its departure, we naturally ask, Just what is this cerebral cortex in whose proper activity we have so keen a personal interest and which plays so large a part in human welfare and progress? And how did it come into being, and what is its general biological and social significance? These questions cannot be fully answered. But sufficient progress has been made to justify a general survey of the problem of the cerebral cortex in its biological and human aspects.

The cerebral cortex makes up about half the total weight of the human brain; it is the most conspicuous and characteristic part of it; and physiologically it clearly dominates and controls the activities, not only of the remainder of the brain, but of the body as a

whole. Looked at anatomically, there is no organ of the human body whose structure is more distinctive and whose recognition is more easy. Nevertheless, there is real confusion about the exact boundaries of the cortex in the human brain and the criteria by which these boundaries are fixed. And there is much uncertainty and great difference of opinion about its physiological action and the way in which its functions are related with those of the remainder of the nervous system.

Turning to an examination of the cerebral cortex of infrahuman species, as we pass down the animal scale we are impressed by the rapid diminution of the mass of the cortex and by the progressive simplification of the histological pattern of its texture, until in lower vertebrates we reach a point where cortex can be recognized with difficulty or not at all. In view of these facts, the question, What is the cerebral cortex? is by no means easily answered, and, in fact, the most diverse views have been expressed.

As the name implies, cortex in general is superficial gray matter, but it does not necessarily appear on the surface of the brain; for we have a cortex of some buried structures, as the cortex of the inferior olive. The two most important superficial cortical sheets are the cortex of the cerebrum and the cortex of the cerebellum.

“Pallium,” or brain mantle, is a morphological term applied to the massive dorsal convexity of the

cerebral hemisphere.<sup>1</sup> The pallium may or may not contain differentiated cerebral cortex, though the terms "pallium" and "cortex" are often used as synonyms. But the anatomical delimitation of the pallium presents even greater difficulty than that of the cortex, so the concept of the pallium does not help to clarify our ideas of the limits of the cortex.

Some have supposed that the superficial gray matter of the cortex assumed this position and in its more elaborated forms became convoluted in response to the nutritive requirements, either to avoid too great thickness of brain substance or to be reached conveniently by the blood vessels, keeping close to the source of the blood supply in the pia mater. It has even been suggested that the cerebral fissures were caused in the first place by the mechanical pressure of the great superficial blood vessels.

The nutritive requirements have apparently played some part in shaping the form of the cerebral hemisphere in primitive vertebrates, as I have elsewhere endeavored to show (1921), and it is not improbable that vascularization from the pia mater is still a contributing factor in the maintenance of the superficial position of the cerebral cortex. But it is evident that gray matter may, on occasion, be developed in similar thin sheets quite independently of

<sup>1</sup> The view expressed by Rabl-Rückhard in 1883 that the membranous roof of the forebrain of some fishes is homologous with the pallium of higher vertebrates is now discredited.

this factor, as illustrated by the deeply imbedded lamellated and convoluted masses of gray found in the inferior olive and the dentate nucleus of the cerebellum.

Various attempts have been made to define cerebral cortex in terms of the number of synaptic junctions which intervene between it and the peripheral sensory surfaces from which it receives its afferent fibers. This criterion is seen to be of doubtful value in many cases, as, for instance, in the cortex of the pyriform lobe and anterior hippocampus, where in the opossum I have shown (1924*b*) that both of these cortical sheets receive fibers directly from the olfactory bulb separated by only one synapse from the nasal epithelium.

Kappers (1913, 1914, 1921) calls attention to other functional factors in the problem, especially to the fact that in all reactions where spatial relations of stimuli and responses enter into the process of adjustment the nervous pathways and correlation centers must maintain their specific separateness. This is facilitated by spreading the adjusting apparatus out in plane surfaces. The case is much like that of a telephone exchange. The wires which come into the building compactly in cables are widely spread out over the switchboards to facilitate precise and rapid connection of any incoming call with any one of the outgoing wires.

These switchboard arrangements are adapted for

the distribution in space of nervous impulses from diverse sources to diverse final common paths, with preservation of the identity and anatomical separate-ness of the several nervous circuits which are thus compounded. This implies that this sort of apparatus is concerned with refined analysis of many afferent systems of different kinds and their regrouping and redistribution through a wide range of efferent pathways. This type of analysis attains its maximum efficiency in the human cerebral cortex.

More elementary mass reflexes as we see them executed in the human spinal cord and corpus striatum do not require this elaborate switchboard type of organization. Here all afferents, no matter of how diverse sorts, discharge into a few final common paths, each of which innervates extensive systems of motor organs, and the adjusting mechanism may be exceedingly simple, as will appear in the account of the correlation centers in the next chapter.

The relation of the cerebral cortex to these primitive mass reflexes or total reactions of the body is a very interesting but still unsolved problem. In some cases the cortex seems to exert a trigger action, releasing (or inhibiting) organized lower neuromotor systems which are already set for the performance of locomotion or some similar elementary form of response.

This implies that in such cases the cortex acts as a "decider," determining whether a particular reflex

apparatus will be put in action or inhibited from action. And since the higher animals have very many of these elementary reflex mechanisms, the determination of which of them will be activated in some particular situation may be a very intricate matter. The intricacy (and efficiency) of the process increases with the improvement of the apparatus for registering effects of past experience and incorporating these organic memories into the functional complex so that we act in response to present stimuli in the light of past experience (Elliot Smith, 1919*a*).

This last seems to be pre-eminently a cortical function in higher animals, yet we have little evidence of it in animals like rats with a simpler grade of cortical organization. We are therefore much puzzled about what the rat's cortex actually does.

As will appear in the course of the subsequent discussion, the cerebral cortex has many other functions besides acting as an arbiter of conduct by "deciding" which of many anatomically possible lower neuromotor systems will be activated in a given situation, that is, by controlling intentionally directed behavior. One of these many functions is to activate or reinforce some particular lower reflex circuits that may already be in process and at the same time to depress or inhibit other reflex circuits that interfere with those which are reinforced. It is, in fact, not improbable that this reciprocal reinforcement and inhibition is an important factor in all cortical control

of behavior, including its part in physiological and psychological choice, associative memory, voluntary effort, and purposive action.

When the whole evidence is reviewed, we find that there is no single anatomical criterion by which cerebral cortex can be distinguished from other sheets of superficial gray matter in the cerebral hemisphere (as the "cortex" of the anterior perforated substance), and in some places cortex passes over into obviously subcortical gray centers by insensible gradations. Though the search for intrinsic anatomical features which specifically characterize cerebral cortex is vain, if we direct our attention to the types of intrinsic and extrinsic connections made by its neurons and to the physiological features related with these patterns of interneural connection, the specific features of this cortex (or some of them) come to light.

A comparison of the cortex of the cerebrum with that of the cerebellum is instructive in this connection. In a recent review of the evolutionary history of the cerebellum (1924*a*) I have called attention to the fact that in the simplest vertebrates the vestibular centers of the medulla oblongata are the cradle of the cerebellum. This is a strictly reflex mechanism of adjustment of equilibration and muscular tone, acting primarily under the influence of the semicircular canals of the internal ear. In the more active animals with greater diversification of bodily movements the cerebral center of this system enlarges and into it are

discharged nervous impulses from the organs of muscle sense, the eyes, and all other sense organs which may serve postural adjustments and the orientation of the body and its members in space. These are the proprioceptive senses, and thus the cerebellum was elaborated as the great central adjustor of proprioceptive control.

The indications are that the cerebellar cortex is concerned more with the convergence and summation of diverse sensory impulses than with their refined analysis and redistribution. Which particular motor centers will receive the nervous impulses discharged from the cerebellum is apparently determined less by what is going on in the cerebellum itself than by what systems are in actual function in the rest of the nervous system. In accordance with the physiological principles of "drainage" and of "induction" (p. 59), the circuits acting in the brain stem tend to capture and utilize the cerebellar discharge. All this is in marked contrast with the cerebral cortex, which is subdivided into very many structurally diverse fields whose functions include the analysis of sensory data, their regrouping, and the determination within the cortex itself of the particular motor systems which are to be activated.

The cerebellum emerged from the vestibular nuclei. In its more highly elaborated forms its functions are enlarged to include some sort of reflex control of all movements of skeletal muscles and of



muscular tone. It is highly developed in all active animals from fishes to men; and, although much larger in higher forms, it is not otherwise greatly modified in internal structure or mode of action. The stimuli by which it is activated arise for the most part within the body, and its activities are wholly unconscious.

The cerebral cortex, as we shall see, in a somewhat similar way has emerged from reflex centers of the forebrain which are activated chiefly in response to what is going on outside the body—the exteroceptive apparatus. In the early stages of its development it seems to serve, like the cerebellar cortex, chiefly as an activator, reinforcing, inhibiting, or otherwise modifying and controlling the innate reflex patterns of the lower centers out of which it has grown.

The cortex of both the cerebellum and the cerebrum exerts a dynamogenic influence upon lower correlation centers, the patterns of whose activities are established subcortically in these more primitive reflex centers. That is, what the animal will do in response to a relatively simple situation is determined by adjustments made in the correlation centers of the brain stem. The cerebellar and cerebral cortex are knit into these lower centers in such a way as to facilitate a reaction whose basic physiological character or behavioristic motive has already been elsewhere determined.

So far there is a parallelism between these two

types of cortex, but there are from the start very fundamental differences between them, and in their more highly elaborated forms they diverge widely in structure and physiological action. The technique and the results of their action in some respects are so unlike that their significance in behavior is as different as two nervous organs can well be.

The cerebellum controls (always unconsciously) the co-ordinated action of various parts of the body under the influence, chiefly, of stimuli arising within the body (semicircular canals, organs of muscle sense, etc.). The cerebral cortex, on the contrary, exerts its influence primarily in relation to responses to external stimuli (exteroceptive reactions) and, in its higher forms at least, occupies a dominant position in the apparatus of intentional control of behavior.

This difference is neurologically, physiologically, psychologically, and sociologically of fundamental significance. For the survival of any organism, whether dogfish or business man, depends first upon his ability (consciously or unconsciously) to adjust his behavior to the environment in which he must live—the exteroceptive reactions—and in the second place to execute a course of action whose end or objective has already been determined with speed, precision, and vigor—and this is fundamentally a proprioceptive reaction.

The proprioceptive activities are of necessity very rapid immediate responses to momentarily changing

attitudes and movements. The cerebellar arcs are knit into the elementary reflex systems in the most direct way possible. In walking, swimming, and flying they control the execution of movements whose directions and objectives are none of their affair. Where the animal is going and what he will do when he gets there are determined in the apparatus of exteroceptive adjustment, to which the cerebellum, like the rest of the proprioceptive system, is subordinate. Highly elaborated cerebral cortex, on the other hand, is an arbiter of conduct; it participates in the determination of the end to be attained in a behavior sequence; it may revamp the "natural" reflex and instinctive patterns, inhibiting, redirecting, or reorganizing them along lines determined within its own organization; its reserves may be drawn upon to give impulsive force to efferent nervous impulses whose motor effect or behavior pattern the cortex itself has conditioned or fabricated; these functions may be performed unconsciously or consciously. The teleology implied in these statements is of the same sort as that seen in every lower reflex; that is, the activities of the cerebral cortex are biologically adaptive because its internal organization is such as to work in response to stimulation in ways that yield behavior appropriate to the situation.

The contrast between cerebrum and cerebellum is very striking in the higher mammals. In rats and other lower mammals, however, it is far less evident.

Indeed, some of the facts to be reviewed shortly seem to indicate that both of these types of cortex act largely through reinforcement or activation of lower centers, but in a different way. Further experimental work is necessary to clarify this subject.

The dominance of the vestibular organs in proprioceptive control is maintained to the end of the history of cerebellar evolution. Even in the human brain some fibers of the vestibular nerve pass directly from their peripheral end-organs into the cerebellum. The result is that the cerebellum is permanently anchored in the immediate neighborhood of the vestibular nerves.

The apparatus of exteroceptive control of behavior, that is, of adjustment to the outside events going on in the world in which we live, has had a very different and much more diversified history. This theme has been elaborated by Sherrington (1906, pp. 324 ff.) in his illuminating discussion of the significance of the "distance-receptors" and the consequences which follow from the dissociation in time of "anticipatory reactions" from "consummatory reactions." The distance-receptors, he says, "contribute most to the up-rearing of the cerebrum." This principle will be repeatedly illustrated in the course of the following pages.

Some particular sense organ may be very highly developed—eyes in the trout, nose in the shark, taste buds in the carp—and the entire action system is

built up around this dominant sense. In each of these cases a different cerebral reflex center—optic, olfactory, gustatory—is greatly enlarged and correlation fibers from other sensory centers converge into it, so that this particular center, no matter where situated, becomes the center of highest physiological dominance, tending to control the general behavior patterns.

Among the fishes very many illustrations of this principle might be cited (for a few examples, see my *Neurological Foundations of Animal Behavior*, 1924, chap. xiv). As the behavior pattern becomes more complicated in land animals, this primitive form of adjustment apparatus is inadequate, and special correlation centers are developed above and more or less separated from those primary sensory centers which receive their excitations directly from the periphery. Thus arise the correlation centers of the thalamus, corpus striatum, and cerebral cortex, each of which is an adjusting mechanism for many different sensory systems no one of which is physiologically dominant over the others. This makes for greater freedom and plasticity of behavior and larger capacity for modifying innate reflex and instinctive behavior patterns in terms of personal experience; that is, it facilitates learning by experience.

In the course of vertebrate evolution the center of highest physiological dominance within the brain, that is, of most effective control of behavior, has

moved progressively forward from midbrain (most fishes), thalamus, and corpus striatum (reptiles and birds), to the cerebral cortex (mammals). This theme has been elaborated by others (e.g., von Monakow, 1910).

The significance of this history for our present purpose lies in the fact that in these progressively elaborated centers of exteroceptive adjustment we see reflected in structure the corresponding enlargement of the behavior patterns. In forms below the mammals these behavior patterns are chiefly of reflex and instinctive types—stable, held in common by all members of a race or species, and modifiable slowly and with difficulty. These animals learn, but for the most part by trial-and-error and only after many repetitions.

In the mammals, especially the higher species, the picture is radically changed. The cerebral cortex structurally overshadows the rest of the brain and physiologically it dominates behavior. The learning pattern changes from slow fabrication of conditioned reflexes by the method of trial-and-error or by mere repetition of simultaneous excitations to direct attack upon the problem and intentional control of the "trials." The appropriate response may be attained at the first overt trial because the tentative movements of inappropriate trials are centrally evaluated (physiologically or psychologically) and inhibited. The explicit or overt behavior is simplified because

the implicit or internal behavior is elaborated and absorbs more of the total process.

This glimpse of the general characteristics and evolutionary history of the cortex makes it evident that no single anatomical or physiological feature will be found which alone can serve to define the cerebral cortex. It is possible, however, to assemble the physiological factors which seem to have conditioned the evolution of these master-tissues. In the following chapters an outline of cortical origins will be sketched in the hope of clarifying the part played by the cerebral cortex in vertebrate evolution, the early steps in its fabrication, and the physiological influences involved.

### CHAPTER III

## REFLEX ACTION AND CONDITIONED ACTION

*The subconscious of a civilized adult reflects all the habits he has acquired.*

—JOHN DEWEY

THE basic function of the cerebral cortex is the correlation and integration of the elements of behavior sequences so that these follow in ways most appropriate for promoting the welfare of the organism as a whole. Here, as so often in biology, the genetic approach offers promise. As this inquiry advances it will be clear that in the course of the evolution of the cerebral cortex it has been slowly elaborated from raw materials originally provided by primitive correlation centers of the fore-brain which do not differ in principle from those of the medulla oblongata. We shall, accordingly, next examine briefly the steps in the differentiation of correlation centers in general.

In the simple reflex, such as withdrawal of the finger from a pin prick, we have theoretically a one-to-one relation between stimulus and response like the ringing of a bell when the push-button is pressed. This is never realized in practice, for there is always some spread of the excitation with various other complications. If two or more sense organs are



simultaneously stimulated, a nervous impulse is transmitted from each to its own primary cerebral center and local reflexes may follow. Since these primary centers are connected with one another

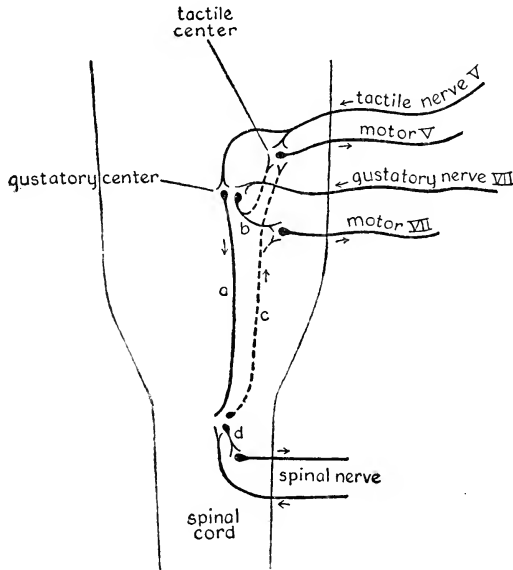

FIG. 1.—Diagram of some of the connections of nerves of touch and taste in the medulla oblongata of the catfish, *Ameiurus*, as seen in longitudinal section.

centrally by fiber tracts, the ensuing response will be the result of the interaction of all of the excitations (Herrick, 1924, chap. xvii). Figure 1 illustrates such a system of connections in a fish brain. Food may be felt through the V nerve and tasted through the VII nerve. If it feels right and tastes right the two stimuli

co-operate, the motor V and motor VII nerves are activated, and the food is held and ultimately swallowed. If it feels right but tastes vile the motor V is inhibited, the mouth opens, the motor VII is activated, and the food is ejected by the tongue. If the feel and the taste are extremely noxious, the nervous impulse also passes down to the spinal cord and the fish swims away.

This is not a hypothetical case; it is well authenticated. Here we have a rather elaborate system of correlations, but no special correlation center is provided. The entire performance is conducted through nervous connections running between the primary centers themselves. What happens in each case seems to be determined by the relative potencies of the several members of the complex.

This sort of mechanism is adequate for many of the simpler correlations, but its range is limited and it is not well adapted for rapid modification of behavior through experience. More complex adjustments, especially those which are individually learned, are more efficiently served by special correlation centers which are not directly connected with any peripheral sense organs or under dominant control of any one sensory system but which have indirect connections with several primary sensory centers. Such a correlation center is not physiologically dominated by any one sensory system; the pattern of its internal nervous connections is not a rigidly fixed fabric of well-

insulated fiber tracts but rather a more diffuse spreading of fibers; it is, accordingly, more impressionable and more readily modified by practice; the resulting behavior is more labile or plastic than that mediated by the primary reflex centers alone. This is the typical apparatus of the formation of so-called associative memories, perceptual-motor learning (Carr, 1925), learning by trial-and-error, and habit formation by repetition, though it must not be forgotten that these activities can be performed (less efficiently) in the absence of correlation centers.

Before proceeding with the discussion of the thalamus and cerebral cortex as apparatus of correlation, brief reference may be made to some interesting steps in the differentiation of the primary sensorimotor centers out of which these higher centers of correlation have been elaborated.

Primitive reactions to external stimulation are generally mass reflexes, or total movements of the body as a whole, such as swimming to or from the source of the excitation. In fact, the simplest vertebrates are so organized that there are very few things that they can do in adjustment to changes in their surroundings. A young salamander larva or a tadpole is well equipped with sense organs. He has nearly as many ways of sensing what is going on around him as we have, but the number of things that he can do about it is surprisingly small.

There is a profound physiological principle behind

the old saw, "I'd rather have fingers than toes." For there is no great development of complex cerebral centers of higher adjustment of behavior in the absence of a sufficiently complex motor apparatus to make efficient use of such enlarged powers of analysis and synthesis of the sensory data. Many authors have pointed out that the primate hand is the precursor of the primate cerebral cortex.

Wood Jones (1916) has developed this idea with a wealth of illustration. He emphasizes also the converse aspect of this matter. The fullest use of a well-developed motor equipment is impossible unless the brain also has attained a grade of organization which is adequate for the realization of the educational possibilities of a complex mode of life.

Physical perfections of adaptation are useless, unless advantage can be taken of them by a specialized type of brain; but specialization of the cerebral architecture cannot proceed in the absence of, yet cannot create, physical specializations in evolution. . . . Neopallial perfections did not, for instance, create the hand, but cerebral advances made possible the full utilization of this very primitive yet very plastic member [p. 198].

A similar argument is graphically presented by Elliot Smith (1924, pp. 33, 36, 145):

Man has evolved as the result of the continuous exploitation throughout the Tertiary period of the vast possibilities which the reliance upon vision as the guiding sense created for a mammal that had not lost the plasticity of its hands by too early specialization.

The development of the behavior patterns and of the correlated nervous mechanisms of young sala-

mander larvae has been intensively studied by Coghill (1909-1926), and I have devoted considerable attention to the central mechanisms of correlation employed in later developmental stages of these animals (see the summary by Herrick and Coghill, 1915).

From all of these researches it seems probable that functional differentiation in the phylogeny (as in the ontogeny) began at the periphery; and here the elaboration of functionally specific end-organs and conduction paths advanced much more rapidly on the sensory side than on the motor side of the reflex circuits.

This does not mean that the sensory paths become functional in embryonic development earlier than the motor paths. In fact, in the development of the spinal cord of *Amblystoma* larvae the converse is true, as Coghill (1913) has shown. But it does imply that in the progress of differentiation the sense organs are structurally adapted to respond in a selective way to a great variety of external stimuli at a stage when the motor apparatus is so simply organized that there is possible but little variety of modes of response to these excitations.

At an early larval stage when all of the sense organs and sensory components of the peripheral nerves are differentiated substantially as in the adult, the motor mechanisms of the spinal cord and nerves may show very little evidence of capacity for diversified response, simple swimming movements toward

or away from the source of the stimulus being almost the only possible reactions. In other words, the elaborately diversified receptor mechanisms converge into very simply organized final common paths. Even in the half-grown larva the motor apparatus of the spinal cord seems to be arranged to serve chiefly total reactions of the simplest locomotor type. The spinal cord of larval *Amblystoma* may be compared with a house provided with many entrances and but one exit; that of a mammal with a house provided with still more entrances and also a large number of exits.

Primitively, the medulla oblongata was probably organized much like the spinal cord just described, nervous impulses from the various sense organs of the head (tactile, gustatory, etc.) discharging into a common nervous center. This center in higher animals has been broken up into a number of separate primary sensory centers, one for each of the sense qualities received by this part of the brain.

An interesting transitional stage in the development of specificity of primary sensory centers is found in the medulla oblongata of larval *Amblystoma* (Herrick, 1914). On the left side of Figure 2 we see lateral line fibers (*l.l.X.*), vestibular fibers (*n.VIII.*), and tactile fibers (*gen. cut. X.*) discharging into a single correlation neuron, whose axon crosses to the other side and enters a correlation tract (*lm.*). On the right side of the figure a gustatory fiber (*visc. sens. X.*) and a tactile fiber (*gen. cut. X.*) discharge

into a single neuron, whose axon divides, sending one branch (*tr. v. a.*) to a higher visceral correlation center and another branch (*tr. b. t.*) to the opposite

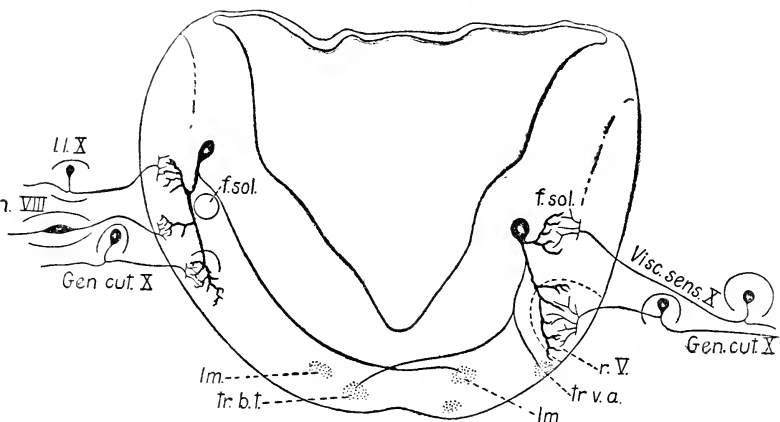

FIG. 2.—Diagrammatic cross-section through the medulla oblongata of larval *Amblystoma* to illustrate types of reflex connections with convergence of different sensory systems into final common paths. On the right side, fibers of gustatory sensibility (*Visc. sens. X*) and fibers of general cutaneous sensibility (*Gen. cut. X*) discharge upon a single sensory neuron whose axon divides to enter correlation tracts of the same and the opposite side. On the left side, fibers from lateral line organs (*l. l. X*), from the internal ear (*n. VIII*), and from the skin (*Gen. cut. X*) discharge upon a single neuron whose axon crosses to the opposite side and then ascends to higher correlation centers through the lemniscus (*lm.*). From Herrick and Coghill (1915).

side and then to a higher exteroceptive correlation center.

Evidently in these cases the reaction following peripheral stimulation will be a sort of physiological resultant of the interplay of the various sensory excitations as they discharge into final common

paths. In the human medulla oblongata each of these various sorts of sensory fibers enters its own local specific primary sensory center (tactile, gustatory, etc.), and the analysis of sensibility made by the peripheral sense organs is preserved in the primary centers. The final integration of these diverse sensory modalities is made in higher correlation centers. This increase in structural complexity of the brain permits much more diversified responses to external stimulation than are possible in a tadpole, and the switch-board apparatus of the higher correlation centers is correspondingly enlarged.

Recurring to our analogy of a house with many doors, the medulla oblongata of larval *Amblystoma* may be compared with a building containing a large central hall, admittance to which may be gained from the outside through many doors; and leading out from the main hall is a smaller number of short, wide corridors some of which lead directly to exits, others to a common living-room in another part of the dwelling. The mammalian medulla oblongata, however, is more like a large apartment building composed of many suites, each with its separate entrance and exit, but the inner rooms of all having free communication from suite to suite and also with a series of large common living-rooms. Here the individual suites would correspond with the separate reflex circuits and the common living-rooms to the higher correlation centers.



In these amphibian larvae various fiber tracts which discharge specific kinds of sensory nervous impulses upward into the midbrain and thalamus are recognizable, though they are not functionally completely segregated. Essentially the same relations are found in the adult mudpuppy (*Necturus*). Parallel with the differentiation of the several ascending sensory systems of fiber tracts from their respective primary lower centers, the mechanism of integration is elaborated in the higher correlation centers. The complexity of these higher centers need not be great so long as the effector apparatus is relatively unspecialized, that is, so long as the range of variety of possible responses to stimulation is relatively small.

This seems to be the condition realized in the brain of *Necturus*. Here the roof of the midbrain, the entire betweenbrain, and probably to a less extent the cerebral hemispheres serve this integrative function and in connection therewith organize the afferent impulses in such a way as to insure their discharge into the appropriate motor centers. But the nervous connections which I have described (1917) indicate that the functional specificity of these regions is even less sharply differentiated than in the case of the primary sensory centers in the medulla oblongata.

In Figure 3 we see how correlation fibers from the primary acoustic and tactile centers and fibers from the retina may converge into a single neuron whose

axon forms a final common path for all of them. In man there are in the midbrain and thalamus separate centers for all of these systems, and their integration

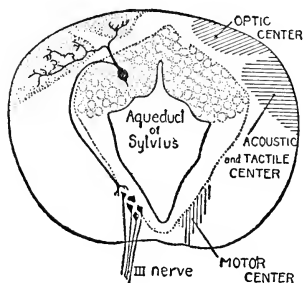

FIG. 3.—Diagram of a cross-section through the midbrain of *Necturus*, illustrating a single correlation neuron of the mid-brain roof. One dendrite spreads out in the optic center among terminals of the optic tracts; another dendrite similarly spreads out in the acoustic and tactile center. From Herrick (1913); for the details of this apparatus see Herrick (1917).

is effected by a much more complex apparatus, a part of which is in the cerebral cortex. In the Amphibia much simpler mechanisms are found in the midbrain for summation of stimuli of diverse sorts and doubtless for various inhibitions from conflict of sensory impulses and of these with mnemonic vestiges of previous experience; but there is very imperfect provision of the apparatus for functionally separated reflex connections with clearly defined localization in space adapted for diversified specific responses to particular kinds of excitation. The

movements, though of a very precise character of high adaptive value, are still largely on the plane of total reactions to a general situation, rather than diversified movements, each of which is in response to some particular factor in the stimulus complex.<sup>1</sup>

<sup>1</sup> On the behavior of *Necturus* see Whitman (1899, p. 295), Eycleshymer (1906), Reese (1906), and Sayle (1916).

Even in the primitive brain of *Necturus* the reflex centers of the midbrain are complicated by the fact that the efferent tract from the midbrain roof divides into a descending and an ascending path. The latter

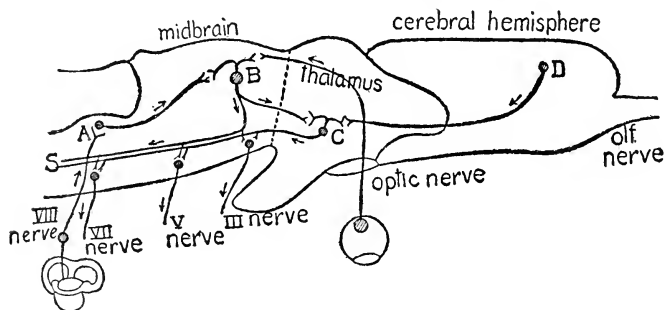

FIG. 4.—Diagram of some conduction paths in the brain of *Necturus*, seen in longitudinal section. From the medulla oblongata an acoustic impulse may be carried forward through the neuron *A* to the midbrain, whose neurons, *B*, are of the type shown in Fig. 3, receiving both acoustic and optic impulses. The neuron *B* may discharge downward through the tract *S* to the motor nuclei of the III, V, VII, etc., nerves, or it may discharge upward to a neuron of the thalamus, *C*, which also receives descending impulses from the cerebral hemisphere through the neuron *D* and in turn discharges through the motor tract, *S*.

ends in the thalamus, where associations of a still higher order are effected through the thalamic neurons (Fig. 4, *C*). Here again there are no specific "nuclei" in the thalamus, merely an undifferentiated field where still different kinds of nervous impulses from the cerebral hemispheres may play upon the apparatus of correlation and so change the dynamic equilibrium of the reacting system as a whole.

In these generalized Amphibia we are evidently

near the beginning of the history of the elaboration of the nervous mechanisms of correlation and integration. We find highly developed sense organs which analyze the environmental agencies in very specific ways. At the opposite or motor end of the reflex apparatus we find again a system of very specific organs of response, but so organized as to permit very few kinds of movement. Between these there is interpolated a nervous adjustor of simple pattern so arranged that all sensory impulses may be converged into a few motor paths. The specificity of the receptive apparatus is quickly lost or generalized. All kinds of sensory impulses converge upon a few neurons whose efferent discharge is the resultant of the interplay of all of the entering energies.

With advancing specialization in higher animals the lower primary reflex centers acquire more specific characteristics, and fixed systems of correlation fibers are laid down between them, thus establishing progressively more complex patterns of stable behavior. But the convergence and interplay of diverse sensory impulses and their interaction in determining the nature of the resulting movement is only moved farther back from the sensory surfaces. Progressively more complex correlation centers are elaborated in the midbrain, thalamus, and cerebral cortex, and here the specificity of the sensory systems sooner or later disappears in a common meeting ground. The association centers of the human cerebral cortex present

the final stage in this process. The absence of specificity or of physiological domination by any one sensori-motor behavior pattern is their most characteristic feature. Otherwise they would be incapable of performing the marvelous feats of recombination and reintegration of sensory experience which come to expression in intelligently directed behavior and in creative imagination.

We conclude that during the progress of vertebrate evolution the complexity of stereotyped behavior patterns has increased and parallel with this the structure of the brain stem has been complicated by the fabrication of numerous specific reflex centers, all interrelated by well-insulated fiber tracts. This is the apparatus of routine behavior—immediate sensori-motor reactions. Now, if these numerous stabilized components of behavior are on occasion to be combined in unaccustomed ways or redirected to new ends—if, in short, the animal so generously endowed with reflexes and instincts is able to learn to do new things—then the switchboards into which all these processes are converged must be correspondingly enlarged.

The thalamus and the cerebral cortex are such centers where many diverse systems of accustomed nervous activities may impinge and react one upon another. These parts of the brain retain even in the highest animals something of that generalized or non-specific sort of nervous organization which is so

characteristic of the most primitive nervous centers. They contain an ample amount of what Child would call "physiologically young tissue," that is, tissue which has not matured in rigid molds but is still plastic and readily modifiable (Herrick, 1924, p. 252).

This does not mean, as Lashley seems to imply, that in these higher correlation centers the tissue is equipotential and that conduction is diffused uniformly throughout a physiologically homogeneous network of fibers. The anatomical structure of these centers is well known. The neurons involved are in synaptic relation with one another, and the direction of conduction at any moment is probably influenced by the physiological state of the synaptic junctions at that moment.

These centers possess the apparatus for wide dispersal of all incoming nervous impulses and for the interaction of one system of such impulses upon another. During the formation of a new habit, definite preformed nervous pathways leading into and out of the correlation center are activated, and within the center new patterns of interaction of these systems may be formed and perpetuated just because the preformed pathways here converge into a tissue lacking such inborn patterns of interneuronic connection. After completion of the formation of the habit, definite pathways of nervous discharge through the correlation center have doubtless been established, and the plasticity of the behavior pattern is

probably directly proportioned to the ease with which these personally acquired connections can be made. Ramón y Cajal remarks (1911, p. 888):

The extension, the growth, and the multiplication of the appendages of the neurons, moreover, are not arrested at birth; they go on after that time; and there is nothing more striking than the difference between the nerve cells of the new-born and those of the adult as regards the length, number and complexity of their ramifications. Doubtless exercise is not without influence upon these alterations, which are probably more marked in certain spheres of the brain of the cultured man. Lack of exercise, on the other hand, should evoke in the inactive spheres of the brains of both cultured and uncultured men those phenomena of resorption which have been observed during the embryonic period and which here come to expression as forgetting, etc.

The nervous mechanism of inborn reflexes, and of "conditioned" or acquired modifications or recombinations of these reflexes, is fundamentally the same. The difference between the primary reflex centers and the correlation centers lies in the ease with which in the latter the inborn connections can be altered by personal experience and in the resulting increase in the flexibility and complexity of the behavior patterns—a difference of very profound significance.

It is clear that in the thalamus and cerebral cortex are performed essential parts of many learning processes. Pavlov's conditioned reflex (or, more appropriately, conditioned response) is a typical illustration of the process. In dogs these learned reactions generally involve the cerebral cortex as well as the

thalamus (Pavlov, 1923), but in their simpler forms the thalamus alone is competent, as shown by the fact that such associations can readily be acquired by fishes, in which the cerebral cortex is absent or very rudimentary, and by invertebrates.

Whether a rat deprived of all its cerebral cortex can acquire conditioned reactions or simple sensori-motor habits has not been fully investigated. It is to be expected that this can be done in the case of some simple acquired habits. The experiments of Lashley to be described in detail in subsequent chapters show that simple habits can be acquired in the absence of most of the cortex, and Jellinek and Koppányi (1923) report a similar case in which all or nearly all of the cortex of a rat was destroyed and simple associative memory habits were subsequently acquired.

Figure 5 illustrates the apparatus of associative memory in greatly simplified form, using Pavlov's conditioned salivatory reflex as an example. Stimulation of taste buds on the tongue activates the primary gustatory center through the VII nerve. This in turn excites the salivatory nucleus and the submaxillary salivary gland. This is a local reflex arc of the medulla oblongata provided ready-made at birth, and salivation in response to food substances in the mouth is not a learned reaction. The VIII nerve passes from the cochlea to the primary auditory center, from which a pathway runs to the spinal cord and out to the neck muscles for turning the head toward the



source of the sound. This, also, is an innate reflex. There is no direct connection between the primary auditory center and the salivatory nucleus, and sali-

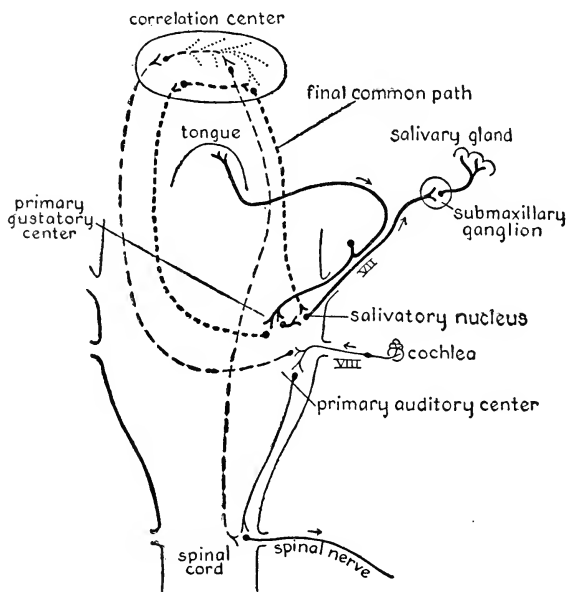

FIG. 5.—Simplified diagram of the conditioned reflex. Primary (unconditioned) taste-salivatory arc in heavy continuous lines. Primary auditory-head-turning arc in thin continuous lines. Secondary loops to correlation center in broken lines.

vation does not naturally follow excitation of the auditory organ by a sound.

If a bell is rung every time the animal is fed, he learns to associate the bell with food, and ultimately he will salivate at sound of the bell alone, even though

no food is presented. The neurologic mechanism involved in its simplest possible form is shown in the diagram by the broken or dash lines. From the primary gustatory center a path ascends to a higher correlation center, thence by a return motor path to the salivatory nucleus, so that in the "natural" reaction the higher center may be involved, as well as the medulla oblongata. From the primary auditory center, also, a pathway ascends to the correlation center. The "natural" return path for this system leads to the spinal center for turning the head. But within the correlation center there are various collateral paths (drawn as fine dotted lines).

The centers and definite fiber tracts employed in the natural reflex behavior are laid down in the innate structural organization. These pathways are taken by preference in all ordinary reflex behavior. The collateral connections indicated in the diagram by the fine dotted lines spread out diffusely through the correlation center without forming definite fiber tracts between specific functionally defined regions. The result is that the activation of the fixed innate reaction mechanisms results also in an irradiation of nervous excitation throughout the correlation center as a whole. This may lower the threshold of all parts of the center for any other kind of excitation.

In the early stages of training the excitation of the auditory system by ringing the bell does not of itself cause salivation because there is no preformed path-

way between the auditory and the salivatory paths; but by reason of the spread of these auditory excitations throughout the correlation center the entire center is partially activated. This activation is adequate at first to produce a reaction only through the natural pathway leading down to the spinal cord for turning the head. If the ascending gustatory path is simultaneously acting upon the correlation center and thence down by its own path to the salivatory nucleus, this latter discharge is reinforced or facilitated by the diffuse excitation already acting from the auditory path. The threshold for the salivatory reflex is thereby lowered because the entire center is partially activated and "primed" in advance. For illustrations of such reinforcement see Yerkes (1905); for the mechanism involved see Herrick (1913, 1917).

It is well known physiologically that a nervous circuit which is in action is prepotent over resting circuits, and when a response is in process intercurrent stimuli tend to affect the acting circuit rather than to activate resting systems of neurons which would otherwise be excited. This is usually ascribed to the greater permeability of the active systems, whose internal inertia has already been overcome so that they tend to capture or draw off available nervous energies from surrounding parts. In accordance with this principle the diffuse or non-specific activation of the correlation center by the auditory stimulus finds an outlet already open through the descending

salivatory path which is already activated, as well as through its natural motor path to the spinal cord.

This explanation, of course, applies only in cases where the two stimuli are simultaneously acting, and conditioned responses occur under many other circumstances. These cannot be reviewed here, and the instance cited must be taken as illustrative of the type of situation presented in conditioned responses rather than as an adequate analysis of any of them.

By the conditions of the experiment cited the salivatory reflex is a satisfying reaction; that is, it is adaptive as defined by Carr (1925, p. 72) in that it alters the situation in a way that satisfies the motivating conditions. It is part of the feeding reaction. The head-turning reflex in some cases may also be adaptive, but under the conditions of this experiment it is not satisfying; no significant motivating stimulus is involved, for dogs do not naturally respond to dinner bells.

Upon many repetitions the salivatory reaction is therefore perpetuated and strengthened by use and the head-turning reaction, which has no "adaptive" significance, is gradually eliminated. The salivatory response is dominant over the head-turning response. By simultaneous excitation of the gustatory and auditory systems the satisfying or adaptive salivatory reflex is facilitated, for the salivatory path from the correlation center receives a part of its activating energy from the auditory stimulus which is simultane-

ously discharged into this center. That which was at first a non-specific diffusion of the auditory stimulus finally comes to be converged into a newly acquired specific conduction path between the auditory field and the origin of the descending salivatory path.

It is not clear just what is the mechanism of this facilitation and the opening up of a new associational pathway, though there can be little doubt that something of this sort does take place.<sup>1</sup> There is probably some enduring structural change in the interneuronic connections within the correlation center which fixes and preserves the newly acquired association. The principle most commonly invoked here is the one already mentioned, namely, the capture by an activated path of all available energy from surrounding parts by reason of its lowered resistance or increased permeability to conduction during functional activity, a process which is sometimes called "drainage" or "induction" (Sherrington, 1906, p. 206). Thus in the course of the acquisition of the auditory-salivatory conditioned reflex a particular path through the correlation center which has adaptive value in that it eventuates in a feeding reaction is facilitated by use until it is taken to the exclusion of the non-adaptive pathways. The animal has "learned" to salivate when the bell rings.

<sup>1</sup> Hulsey Cason (1925*b*) has published a general review of the literature of conditioned responses. Two recent articles by the same author (1925, 1925*a*) take up some of the theoretic problems of the relation of conditioned responses to the learning process.

There are many experimentally established facts about conditioned reflexes which are not explained by the much-simplified statement here presented, but into these details we cannot enter. Beritoff (1924) gives a good account of some typical experiments and discusses in detail the laws of the spread or irradiation of natural and conditioned excitations within the cerebral cortex and the activating and facilitating effects of repeated excitations, both simultaneous and successive.

In the course of the discussion of the neural mechanisms of attention, Johnson (1925) presents an elaborate diagram of the nervous circuits that may be involved in a simple response to sensory stimulation, and of the related circuits which may modify this response through simple reinforcement by additional stimulation, through conditioning of the response by simultaneous or preceding responses, through preservation (with the aid of reflex arcs related with muscle spindles) of enduring motor "sets" or "cues" in delayed reactions, through distraction (inhibition) or reinforcement (facilitation) by intercurrent stimuli, diffusion, and "drainage." Throughout this entire sequence of events, particular neurons related in specific patterns are successively activated. The facile modifiability or plasticity of the behavior pattern is correlated with the complexity of the interneuronic connections available in the correlation center and the ease with which changes in

peripheral stimulation or internal state of the central neurons may divert the flux of nervous transmission now in one direction, now in another. The prevailing view is that the mechanism of this central readjustment inheres chiefly in variable permeabilities at the synaptic junctions, though this is doubtless only one of many factors in the process. Johnson's hypothetical neural scheme, as he points out, "would be preposterous if taken too literally," yet to the present writer some such analysis of the mechanisms of correlation seems to be quite in harmony with our best available evidence.

That there is a diffuse irradiation of any nervous excitation throughout the correlation center is suggested by the fact that in the early stages of training the acquired or conditioned reaction is generalized, that is, it can be elicited not only by the specific stimulus by which it was established, but also by other stimuli of a similar kind. If the association is made for only a tone of particular pitch, it may at first appear in response to tones of other pitch, though later these "generalized" responses disappear. At any time, moreover, an increase in the excitability of the brain, no matter by what means brought about, will favor the appearance of generalized responses.

The map of these pathways presented in Figure 5 is schematic, and some of the anatomical details have not been fully established. But enough experimental evidence has been accumulated regarding this

and similar conditioned responses to confirm both the neurological outline and the general physiological principles essentially as stated, though it must be kept in mind that this statement is incomplete and by no means covers all of the factors involved.

The thalamus of lower vertebrates as a true correlation center certainly can perform functions in the simpler types of learning of the sort here illustrated, without cortical participation. This readjustment of thalamic neural arcs is, however, a slow and difficult process, and many repetitions are necessary. Learning by trial-and-error is typical of this sort of education.

In still more complicated learning processes the co-operation of the cerebral cortex is known to be necessary, and one of the major problems before us is the exact part played here by the cortex. It is clear that animals with large and very complex cortical development (and man in particular) learn more by personal experience and learn more rapidly. Their learning curves may be radically different from the usual trial-and-error curve.

The lower vertebrates may, on occasion, acquire a new mode of response after a single experience, but more often the learning is a slow process involving much random fumbling as overt behavior. The man more readily reaches a correct solution of the problem of conduct in an unfamiliar situation without random overt trials, though the "trials" which do not come to



overt expression may be as numerous and the total time of learning may be greatly prolonged. We say in this case, the problem is solved by "insight," but this does not tell us anything about what the insight is or its mechanism. Apparently, the more impressionable cortex receives and holds records of individual experience more readily than does the thalamus; these records can be woven into new patterns; inventiveness takes the place of blundering or random attack upon an unfamiliar situation; progressively more of the behavior is transferred from the explicit to the implicit form.

This, briefly, seems to be the history of the elaboration of the apparatus of correlation in the vertebrate series as viewed in its physiological aspects. Our knowledge of the anatomical mechanisms involved is still inadequate, but enough is known of this subject to permit a tolerably good parallel outline of the structural evolution of the nervous system and the minute details of its internal organization. Limitations of space forbid the presentation of this anatomical detail in this work except in meager outline.

In the preceding discussion the attempt has been made to avoid dogmatism about the actual mechanisms employed in conditioned reactions while outlining a theoretic analysis which seems best to fit all of the known facts. There is ample room for other explanations. Lashley (1924a) has, in fact, performed a useful service in demanding a critical re-examination of the current views here summarized, and his comments merit brief consideration.

The experiments cited by Lashley in refutation of theories of diffusion and "drainage" or "induction" are far from convincing. These concepts have doubtless been greatly overworked by theorists, but in their elementary forms they rest upon a large body of experimental data. It is true that our knowledge of the precise mechanisms employed in irradiation, in "drainage," in facilitation by use, and in the fabrication of new learned patterns of behavior is still incomplete, but the cases cited by Lashley in refutation of these theories and of the doctrine of variable synaptic resistance are in reality wholly irrelevant, as a neurological analysis of the experimental data would show.

It would be out of place here to go into the technical details of such a neurological analysis. In one passage Lashley substitutes for the current theories mentioned above the utilization of efferent paths which were not functional during learning. After destruction of the arm area of the right precentral gyrus of a monkey and subsequent training of the right hand with a problem-box, the arm area of the left cerebral hemisphere was then destroyed. It was later found that there was almost perfect transfer of the habit from the trained but now enfeebled right hand to the untrained left hand which had been partially paralyzed throughout the training but was now almost fully recovered. From this it is concluded, "We have evidence of the utilization of neural paths in the performance of a learned reaction which were not activated during the course of learning. In this case the drainage theory is definitely ruled out."

This is a gratuitous assumption, for there is an immense complexity of neural architecture in addition to that of the precentral gyrus which was certainly involved in this training and which may have been entirely unaffected by the operations, and drainage or any other process which one wishes to hypothecate may have been involved in the transfer of the training to the other hand. These monkeys had damage done only to a sector of the final common path which may be utilized not only by this habit,

but by countless others. The engram of the particular problem-box habit in question is certainly not in the precentral gyrus (which alone was injured); it must lie in some premotor arrangement of associational neurons not at all affected by the operations. The other cases cited are similarly inconclusive.

In another place, Lashley says, "it is characteristic that the conditioned reflex is not built up gradually, but is fully integrated when it first appears." Of course, the last statement must be true, for this type of learning does not involve the gradual formation of new elementary behavior patterns but only the doing in unfamiliar situations of perfectly familiar things for which definite neural mechanisms are already laid down in innate or habitual organization. When an auditory stimulus which does not ordinarily produce salivation is diverted to the salivary path, a fully integrated salivation follows as soon as the proper central connection is made for the salivatory mechanism is preformed and ready to operate perfectly as soon as it is activated from any source. The physiological problem is, How is the central transfer made from the "natural" auditory efferent path to the "natural" gustatory efferent path leading to the salivatory nucleus? The evidence is clear that this reorganization of the conduction pathways within the correlation center is usually very gradually effected. It may require a hundred experiences to perfect it.

This is the way learning is usually effected in lower animals. But in higher mammals, where cortical associational tissue is abundantly developed, the picture is different. In man and the larger apes (Köhler, 1925) a new combination of the elements of a behavior pattern or an adaptation of familiar behavior patterns to a new situation may appear suddenly when the animal "sees through" a problem of conduct to an immediate solution without overt trials or random fumbling. This type of behavior has not been discussed in this chapter. It involves the use of a sort of neural organization quite different from that which is adequate

for the simpler conditioned responses, as will appear in our account of the association centers of the cortex.

Again Lashley says, "We may have to seek for changes in the refractory period rather than at the synapse as the basis of the learning process and for changes in the periodicity of discharge within a syncytium rather than for anatomically defined conduction paths to account for new integrations." But it must be kept in mind that anatomically defined conduction paths are present and are certainly employed throughout most, if not all, of the way traversed by the nervous impulses involved in conditioned reflexes. An appeal to a syncytium in the correlation center where the transfers effected in learning are actually made leaves us in worse state than before, for this involves the total disregard of the most valuable anatomical and experimental evidence now at our disposal for elucidating the mechanism of correlation.<sup>1</sup>

As I have elsewhere pointed out (1924, pp. 103, 114, 255, 258, 266), non-synaptic or syncytial nervous systems lack the machinery necessary for that plasticity and rapid reorganization of the stable elements of a complex action system requisite for facility in learning. And the experimental evidence relating to periodicity of nervous discharge and alterations of refractory period suggests that many of these phenomena center about the synaptic junctions, whose peculiar biophysical and biochemical properties are essential conditions for the manifestation of some of these phenomena (Lillie, 1923, p. 272).

Our conclusion is that, though adequate experimental proof of the theoretic parts of current expositions of the nervous appa-

<sup>1</sup> Professor Lashley in a personal communication indicates that in his use of the term "syncytium" he did not intend to stress the most distinctive characteristics of the non-synaptic nerve net which this word usually suggests in current discussions—an important point to bear in mind in reading his text. He says, "I had in mind irradiation or diffusion as the outstanding property of the syncytium but did not mean to deny synaptic structure or one-way conduction in the cortex."

ratus of correlation and learning is incomplete, yet the hypothesis that best fits all of the known facts recognizes variations in the permeability of the synaptic junctions as one important factor in the modification of behavior patterns. The well-known structure of the correlation centers exhibits ample mechanism for diffusion or irradiation of nervous impulses beyond the limits of the circuits traversed by routine reflex responses, for summation and intensification of nervous discharge, and for the collection and redirection of such diffused nervous activity by changes in the internal state of the synaptic junctions involved in such a complex feltwork of nervous terminals. The nervous energies which are released within the complicated fabric of neurons and their fibrous processes of which each correlation center is composed apparently form an integrated dynamic system whose manifestations in overt behavior will vary with the fluctuations of the energy discharge within the center. There is every reason to assume that this tissue, like every other protoplasmic structure, is more or less permanently affected by repeated function and so habitual patterns of action tend to be perpetuated. "Practice makes perfect" here as everywhere else. This is the familiar physiological principle of facilitation by use, the organic basis of habit, a principle that holds its own despite the rather uncritical attacks recently made upon it by Hulsey Cason (1924) and others.

This dynamic conception of the mode of action of the correlation centers presents an intelligible and fairly well-authenticated account of the apparatus of stimulus-response physiology and at the same time pictures an organization adequate for envisaging the total situation as a dynamic "pattern-reaction" with an internal structural configuration correlated with the behavior configuration as this is described in current literature of the *Gestalt* psychology.

## CHAPTER IV

### THE ORIGINS OF THE CEREBRAL CORTEX

*There must be a number of anatomical arrangements which are present in the same form in all vertebrates, arrangements which mediate the simplest manifestations of the activities of the central organs. In order that any particular mechanism may be understood, we have only to discover the species of animal or the favorable developmental stage of an animal in which it is present in so simple form as to be fully intelligible. When the relations of such a structure, say a fiber tract or a group of cells, have once been accurately determined anywhere, then it is usually easy to recognize them again, even when new complications have more or less obscured the facts.*

—LUDWIG EDINGER

**T**HE cortex of a man is twice as massive as that of an ape of equal body weight. Anatomically, the cerebral cortex is by far the most distinctive human characteristic. It is commonly believed that mankind differs from all brutes even more in the functions of his cerebral cortex than in its obvious structure. But an exact account of just what these functions are and of the mechanisms by which they are performed in either men or brutes is perhaps the biggest biological problem that still awaits solution.

The approach to this problem by way of introspective analysis of human faculties has usually promptly

trailed off into mysticism where science cannot follow. Attempts to solve the problem objectively by analysis of human and animal behavior have so far only raised more new questions without answering the old ones, though they have done great service in clearing the ground of false or misleading preconceptions. Something may be gained by approaching the problem from the other end, by reading the genetic history of the cerebral cortex from the beginning instead of trying to read human faculties backward into the brutes.

But where shall we begin? In the light of cerebral organization of existing vertebrates and of the embryological development of this organization we may recognize four types of cortical structure. These probably represent an approximation to the successive stages in the historical development of the cerebral cortex during the long evolution of the vertebrate branch of the animal kingdom. These types are:

1. *The ichthyopsid type*.—Fishes and amphibians have no well-differentiated cortex, though cortical primordia are evident. That is, the regions within which cerebral cortex appears in higher animals can be identified and in some species these regions exhibit an approach toward cortical structure.

2. *The sauropsid type*.—Reptiles and birds possess clearly defined cortex, though limited in amount and of very primitive structure. The subcortical parts of

the cerebral hemisphere (corpus striatum complex) in these animals are enormously developed.

3. *The mammalian type.*—In even the lowest mammals the cortex is suddenly expanded in amount and elaborated in internal texture. And the process of further elaboration goes on progressively throughout this group.

4. *The human type.*—Man is a mammal and his brain in all respects but one is essentially similar to that of an ape. But the association centers of his cortex are magnified and in internal texture complicated in measure commensurate with his enlarged and glorified mental powers.

These four types or stages are discontinuous. That is, there are no existing intermediate forms. This means, of course, that the transitional species are now extinct; and these missing links have left no record of the internal structure of their brains.

Throughout this series of progressively more complicated cortical patterns no fundamentally new structural features are added. The most highly elaborated cortex is made up of neurons of substantially the same sort as those of the rest of the brain. Anatomically, this progressive evolution appears to be wholly a matter of increase in number of neurons and gradual change in the structural arrangements by which they are physiologically interconnected. We shall next examine briefly the arrangement of the cerebral cortex in representatives of these four types.



THE ICHTHYOPSID TYPE

In fishes and amphibians the cortical primordia are reflex centers which do not differ in principle from

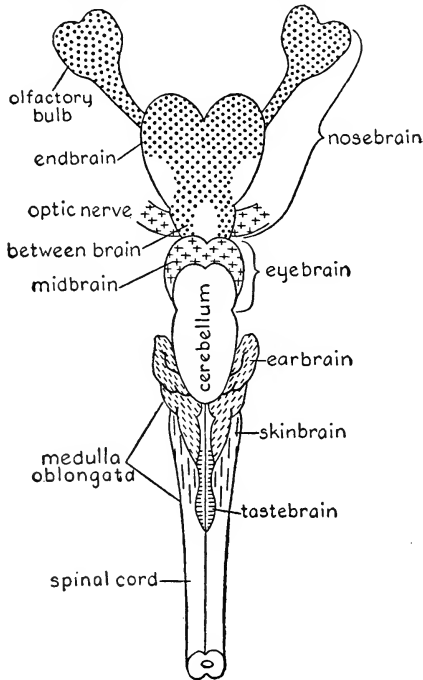

FIG. 6.—Brain of the dogfish, *Squalus acanthias*, natural size. The olfactory field, or nosebrain, is marked with coarse dots, the eyebrain with crosses, the earbrain with oblique cross-hatching, the skinbrain with vertical hatching, the tastebrain with horizontal hatching. The membranous roof of the fourth ventricle has been removed.

those of the rest of the brain stem. The brain of the common marine dogfish (a small shark) is illustrated in Figure 6. Its most striking feature from our stand-

point is the enormous size of the organ of smell and the olfactory reflex centers of the brain (Herrick, 1924, chap. xiii and p. 182). A cross-section through the forebrain of a late embryo of this fish shows that its walls contain several separate areas of densely crowded cells (Fig. 7), which Holmgren (1922) and

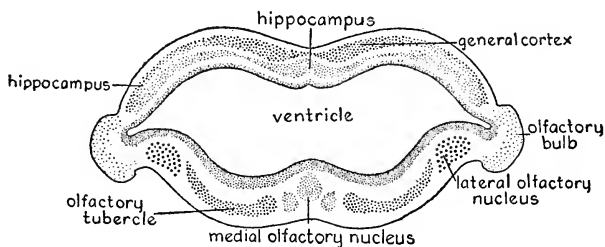

FIG. 7.—Diagrammatic cross-section through the forebrain of an embryo of the dogfish, illustrating the cellular arrangement. The fields designated as general cortex and hippocampus are regarded by Johnston (1923) as primordia of the corresponding mammalian cortical fields.

Johnston (1923) think are beginnings of true cortex. These sheets of cells are less evident in the adult, and until more is known of their fibrous connections the question must remain undecided. The lungfishes (Elliot Smith, 1908; Holmgren and van der Horst, 1925) show clearer evidence of a poorly developed cortical rudiment in the adult.

The shape of the cerebral hemispheres of lungfishes and amphibians (Fig. 8) is much more like that of higher animals than are those of fishes generally, but the internal organization of these brains is much

simpler than that of most fishes. In the frog, the highest of the amphibians, most of the gray matter of the brain is arranged close to the ventricles, which is the early embryonic position. A cross-section of

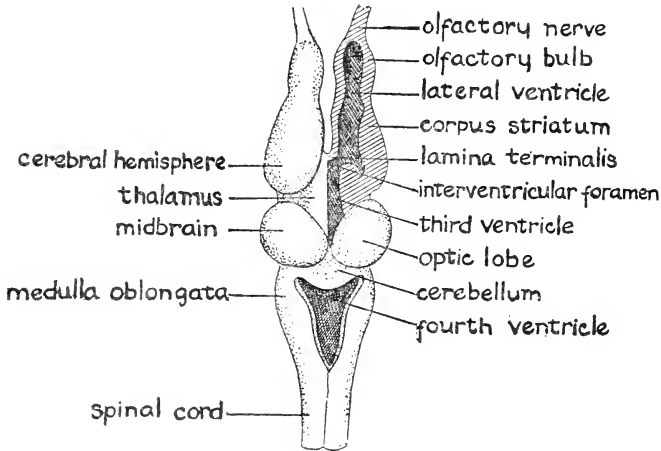

FIG. 8.—Diagrammatic representation of an amphibian brain from which the roof of the thalamus and cerebral hemisphere has been dissected off on the right side, exposing the third ventricle and one of the lateral ventricles. The membranous roof of the fourth ventricle has also been removed. There is a communication between third and fourth ventricles which is not exposed in this dissection.

the cerebral hemisphere of the frog (Fig. 9) shows this primitive arrangement in the lateral wall. The medial wall is more highly differentiated. The wall of this hemisphere is structurally divided into four sectors. Of these, the two dorsal comprise the region within which cerebral cortex is differentiated in higher

animals. The dorsolateral sector (primordial pyriform lobe) shows no tendency toward cortical formation, but the cells of the dorsomedial sector (primordial hippocampus) have begun to move away from the

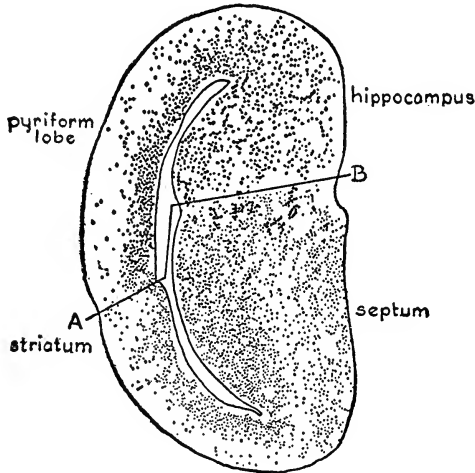

FIG. 9.—Cross-section through the left cerebral hemisphere of the frog to illustrate the arrangement of nerve cells in the different sectors. The parts above the line *A-B* are regarded as regions within which cortex appears in higher vertebrates. Redrawn from Johnston.

ventricular surface and are uniformly distributed throughout the thickness of the wall. This is a tendency toward cortical arrangement though it cannot be called true cortex.

We have little evidence that the reflex functions of the forebrain of fishes differ in principle from those of the midbrain and medulla oblongata, though the

question has never been adequately tested. In the frog the case is different, for decerebration is followed by profound depression and loss of initiative or so-called spontaneity. In the absence of external stimulation the animal tends to squat motionless to the end of life. Most of the ordinary reflex responses to external stimulation (except olfactory) are, however, unimpaired. The cerebral hemispheres here do seem to exert some sort of a dynamogenic influence upon behavior as a whole (see p. 210), though its precise nature has not been determined.

#### THE SAUROPSID TYPE

The reptilian cerebral hemisphere is considerably enlarged as compared with any fishes or amphibians. Figure 10 illustrates the general form of the forebrain of a turtle as seen in longitudinal section, and Figure 23 (p. 106) shows a cross-section taken through the middle of the hemisphere. It is evident that the enlargement over the condition found in the frog (Fig. 9) is chiefly in the lateral and dorsal walls; laterally, we have the corpus striatum complex and dorsally true cortex. The relations of these two parts will be discussed more in detail in the next chapter.

In the most generalized existing reptilian brains (turtles), clearly differentiated cortex has emerged from the reflex centers of the cerebral hemisphere as three separate sheets of superficial nerve cells on the dorsal convexity of the hemisphere. Figures 22-24

illustrate their arrangement as seen in cross-section. Their relations to the underlying reflex centers are significant. The ventromedial sector of the wall of the hemisphere (septum) is a reflex center concerned

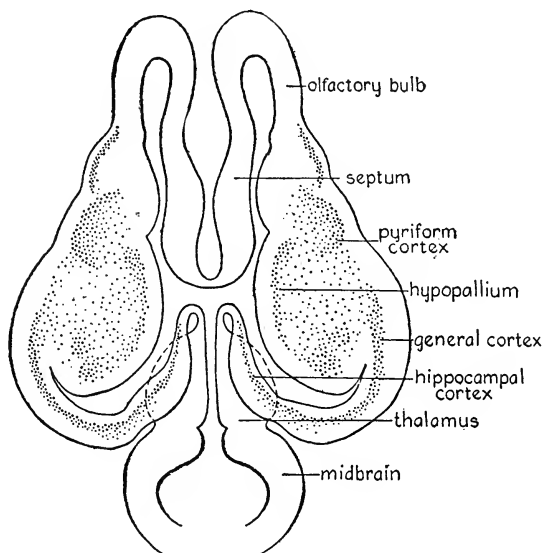

FIG. 10.—Diagrammatic longitudinal section through the forebrain of the box-tortoise, *Cistudo*, to illustrate the arrangement of the cortical fields. In mammals most of the hypopallium is incorporated into the corpus striatum; see pp. 108, 114.

mainly with correlation of olfactory, gustatory, and visceral activities. The ventrolateral sector (corpus striatum complex) is a reflex center with connections similar to those of the septum and in addition a broad connection with the exteroceptive centers of

the thalamus, probably chiefly somesthetic (Huber and Crosby, 1926). This field is enormously enlarged, under the influence of more extensive thalamic connections.

The dorsal convexity contains simply organized cortex. In the dorsomedial sector the cortical differentiation which was foreshadowed in the frog is here actually attained. This is hippocampal cortex, in intimate nervous connection with the underlying septum. The differentiation of this cortical sheet seems to have taken place under the physiological influence of subcortical olfactory-gustatory-visceral reflex systems.

Dorsolaterally, there is a pyriform sheet of cortex, the precursor of the pyriform lobe of mammals. This develops in relation with the underlying corpus striatum and amygdala. Its fibrous connections indicate that physiologically it resembles the hippocampus with the addition of strong exteroceptive influences, probably chiefly somesthetic.

Dorsally, there is a third cortical sheet, detached from the other two, whose fibrous connections with the corpus striatum indicate that its functions are chiefly exteroceptive, with perhaps a motor center in front (Johnston, 1916). This we may call "general cortex," or somatic cortex; it is the precursor of the neopallium of mammals, as the other two cortical sheets are of the archipallium.

Each of these three cortical sheets is thus seen to

be in most direct anatomical connection with its own subcortical reflex center of characteristic physiological composition. There is some localization of function in the cortex from the inception of its differentiation, a localization in space dependent upon a pre-existing anatomical arrangement of the more ancient reflex apparatus of the cerebral hemisphere out of which the cerebral cortex has emerged.

These three cortical sheets are related with one another by intrinsic cortical association fibers in such a way that one of them can probably perform no function independently of the other two. This implies that the interaction of these physiologically different cortical fields is probably an essential feature of all cortical operations.

This cerebral cortex cannot be activated directly from the periphery, but only through the subcortical reflex centers of the cerebral hemisphere and thalamus, which are more highly elaborated than in any amphibians or fishes. Furthermore, there is no pyramidal tract, so that this cortex cannot act directly upon the lower motor centers as the human cortex does; it must exert its motor control through the centers of co-ordination of the striatum, thalamus, and midbrain.

The reptilian cortex is not only simpler, but it is much more intimately knit in with subcortical centers than is the mammalian cortex. It is not capable of so large a measure of independent or local autonomy.



It evidently can influence behavior mediated by the lower centers while this is in process, but apparently little machinery has been elaborated for taking the initiative in the control of this behavior through processes intrinsic within the cortex itself. Accordingly, when a turtle is decorticated there is no very obvious change in the behavior under ordinary laboratory conditions. Doubtless there is an effect upon behavior, but experiments to reveal it have not yet been published.

A type of cerebral hemisphere similar to that seen in turtles seems to have been the point of departure for further evolution of the vertebrate cerebrum. This evolution evidently took two divergent directions: one leading to birds, the other to mammals. The avian line leads up through the higher reptiles, notably the crocodiles, and can readily be followed.

Figure 25 (p. 110) illustrates the brain of the alligator. The subcortical striatal mass is much larger than in turtles and the cortex is more extensive. The three cortical fields are not so well separated anatomically as in the turtle, and a small field at the anterior end is electrically excitable (Bagley and Richter, 1924). In birds the enlargement and complication of the striatum complex has advanced to its culmination in the vertebrate series, but the cerebral cortex has made no corresponding advance. In fact, the avian cortex is more simply organized than the reptilian.

In reviewing the organization of the reptilian cerebral hemisphere two features are noteworthy: First, the cerebral cortex is differentiated in a dorsal field lifted up above the lower reflex centers of the hemisphere and the great lines of fore-and-aft transmission of the brain stem. It is detached in space from the more primitive reflex arcs. It is shunted off above the great lines of through traffic that serve the fundamental innate reflex and instinctive activities. Second, three separate cortical sheets appear simultaneously overlying three more ancient subcortical correlation centers. These lower centers differ among themselves in the reflex functions which they perform, and in reptiles and birds they are greatly enlarged. Cortex is never differentiated in a single physiologically homogeneous field, but always simultaneously in several dissimilar fields. No one of these cortical sheets can be thought of as the exclusive organ of any function, but each is probably essential to the normal working of both of the others if the highest efficiency is to be attained.

These observations suggest two additional things: first, that the cortical functions are something added to the innate reflex and instinctive endowments, not merely more of the same kind of reflexes; and, second, that the most elementary cortical functions involve the association within the cortex itself of diverse physiological complexes in patterns which are not provided for in the more primitive subcortical centers.

No experiments on reptiles adequate to test these suppositions have been published, though it probably would not be a very difficult matter to devise them. In the mammals we have an extensive series of such experiments, and these will be examined critically in due course.

The Amphibia are only partially emancipated from life in the water. Their tadpoles are practically fishes, and the adults of most of the species are more at home in the water than on land. In neither one of these environments are they very competent. Most of the fishes are better adapted for aquatic life, and on land the Amphibia avoid their innumerable and more aggressive enemies only by leading a retired life hidden away in sheltered nooks. This sort of an evasive existence demands no highly complicated cerebration, and indeed this is never exhibited by any of these humble creatures. Most of the reptiles, however, are fully adjusted to the more diversified conditions of terrestrial life; they are enterprising and aggressive in habit and far more complex in bodily structure.

The reptilian brain stem is fishlike in many respects; but these animals can do more different kinds of things with their bodies than fishes and accordingly their apparatus of immediate motor control (that is, the co-ordination centers of the brain stem) is more elaborate. It is in the cerebral hemispheres, however, that the departures from the patterns seen

in fishes and amphibians are most evident. The thalamic centers of sight, hearing, and cutaneous sensibility are large and well separated from one another; and from the thalamus massive tracts run forward into the lateral wall of the cerebral hemisphere. The olfactory organs and cerebral centers of all reptiles are large, but the same is true of most lower forms, and the increment in size and complexity of internal structure of the reptilian hemisphere is to be explained in terms of its more extensive connections with the thalamus, which in turn is correlated with the more diversified adjustments which these animals make to their surroundings in air and earth and water.

The fibers which ascend from the thalamus to the cerebral hemisphere are known as the "thalamic radiations," and the large increase in sensory discharge through these fibers into the lateral wall of the reptilian hemisphere involves a corresponding increment in the hemisphere itself; the larger volume of business to be transacted requires more commodious housing. This increased business is of two sorts, for which two closely related offices are organized: first, a notable elaboration of the reflex and instinctive behavior for which the corpus striatum complex is reorganized on a larger scale; and, second, the differentiation of the cerebral cortex related in some way not clearly understood to more complex behavior patterns. These cortical capacities in reptiles, though

inferior to those of most mammals, are far in advance of anything found in fishes and amphibians. "Wise as serpents" does not mean wiser than all men, but it does mean wiser than any fishes; it does mean improved capacity on the part of the individual to take care of himself in a very complex and unfriendly world.

#### THE MAMMALIAN TYPE

The earliest steps in the elaboration of the mammalian cortex are entirely unknown to us and probably must remain so forever. We know from endocranial casts of fossil skulls that the brains of very primitive mammals were more reptilian in external form than are those of any existing species, but their internal structure can only be surmised. The brains of the most primitive living types of mammals show many reptilian features, but the cerebral cortex of these species is nevertheless distinctly mammalian, not reptilian. In these forms the two salient features of the reptilian cortex already cited are accentuated and the internal structure is far more complex, a development that goes on progressively as the mammalian series is ascended.

The organization of the reptilian cortex is similar, though not identical, in all of the three cortical fields (Fig. 11)—a thin sheet of densely crowded cells, each of which is typically a double pyramid with a dendritic brush at both inner and outer pole. Figures 22,

23, and 24 illustrate in a diagrammatic way the arrangement of the cells in these fields.

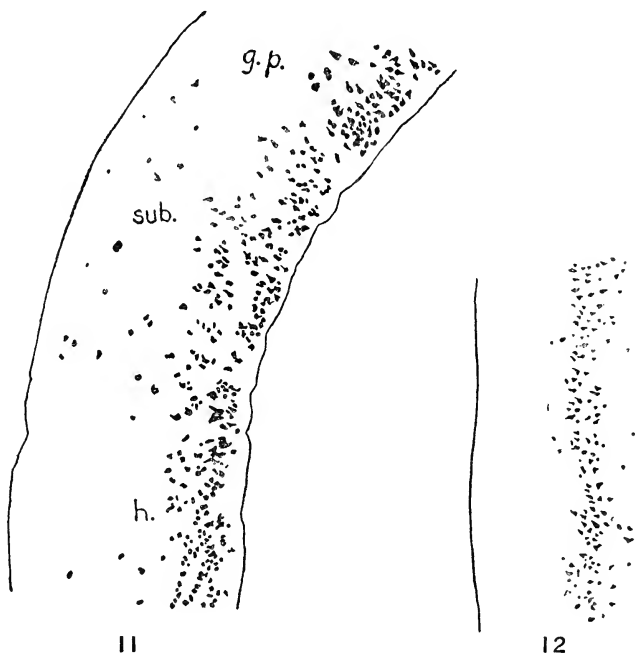

FIG. 11.—Cerebral cortex of the turtle to illustrate the arrangement of cortical cells, magnified 50 diameters. After Johnston (1915). The region pictured is shown in Fig. 23 and includes the dorsal part of the hippocampal cortex (*h*) and the transition (*sub.*) to the general cortex (*g.p.*). The ventricular surface is at the right, where it is evident that the amount of white matter between the cortical cells and the ventricle is very thin. It is much thicker in all mammals.

FIG. 12.—Arrangement of cells in the extreme anterior end of the hippocampal cortex of the opossum at the same magnification as Fig. 11. At the right there is a massive layer of white matter between these cells and the ventricle.

The reptilian type of cortex is preserved in some parts of the olfactory field (archipallium) of lower

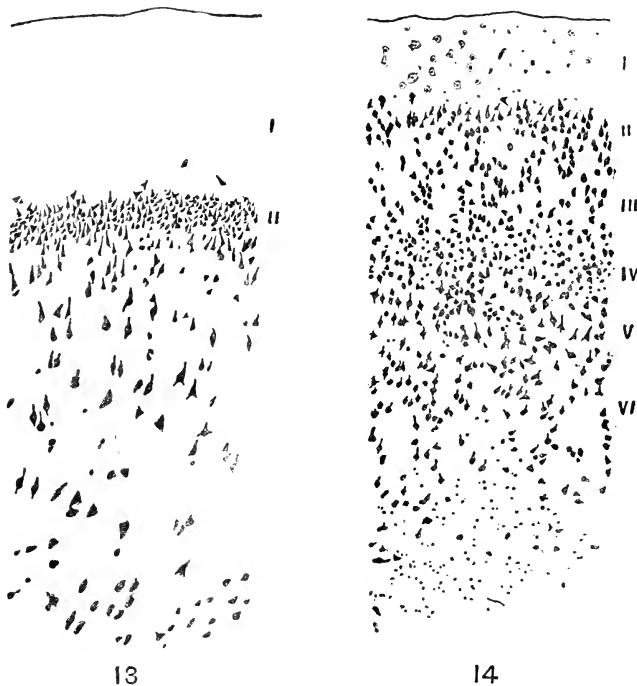

FIG. 13.—Archipallial cerebral cortex of the opossum from the middle of the pyriform lobe (*a. pir. med.* of Fig. 36, p. 154). From an unpublished drawing kindly furnished by Dr. P. A. Gray. Magnification, 50 diameters.

FIG. 14.—Neopallial cerebral cortex of the opossum from the area parietalis or somesthetic-motor cortex (*a. par.* of Fig. 36, p. 154). From an unpublished drawing kindly furnished by Dr. P. A. Gray. Magnification, 50 diameters.

mammals with very little change. Figure 12 illustrates an arrangement of cells in the extreme anterior

end of the hippocampal cortex of the opossum which is almost identical with the reptilian cortex, illus-

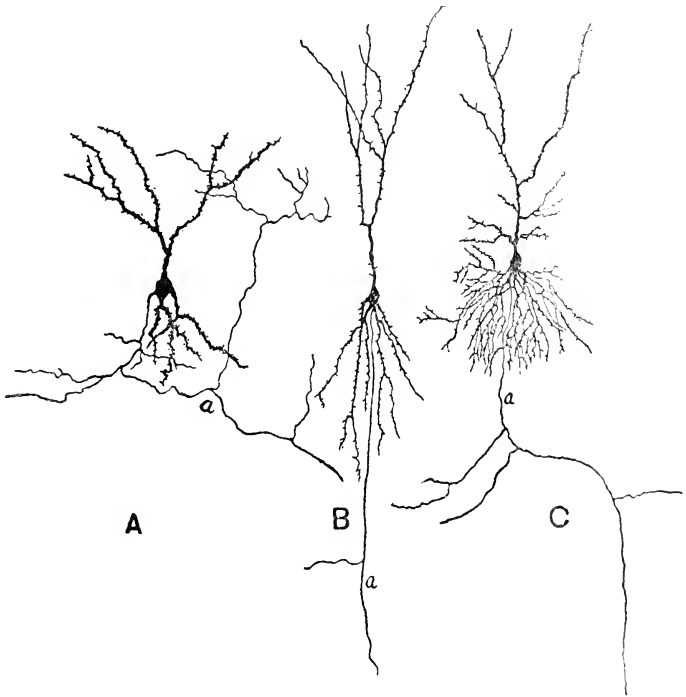

FIG. 15.—Illustrations of typical neurons of the archipallial cortex. *A*, from the hippocampal cortex of the chameleon; *B*, from the pyriform lobe of the cat; *C*, from the pyriform lobe of man. *B* and *C* are taken from an area similar to that illustrated in Fig. 13, layer II. The dendrites directed upward spread in the outer plexiform layer of the cortex (layer I of Fig. 13). The axons (*a*) directed downward enter the white matter. Redrawn from Ramón y Cajal.

trated in Figure 11. The anterior end of the pyriform cortex is very similar. Toward the posterior end of



the hemisphere both hippocampal and pyriform cortex of the opossum become very complicated, but certain features of the reptilian pattern are always preserved. Figure 13 shows the arrangement of cells in the cortex in the middle of the pyriform lobe of the opossum. The most characteristic neurons of all parts of the reptilian cortex and of all parts of the archipallium of mammals are the double pyramids to which reference was made above. Typical forms of these cells are shown in Figure 15.

The double pyramids of the pyriform cortex are arranged in a single compact layer (II, of Fig. 13). One big dendrite extends toward the outer surface of the brain. Here in the plexiform layer (I, of Fig. 13) synaptic junctions are made with various incoming fibers, chiefly from subcortical olfactory centers. A second tuft of dendrites is directed inward and effects synaptic junctions with various associational fibers, chiefly from other cortical fields. This type of polarization of these cells is possible only because the dense cortical sheet is so thin that each neuron can span its entire thickness, thus receiving incoming nervous excitations of different physiological sorts at outer and inner poles. Each of these cells is a correlation neuron of the physiological type already illustrated in a simpler form in the amphibian midbrain (Fig. 3, p. 48). Adequate switchboard space for the larger number of elements is provided by removal of the cells from their primary position next the ventricle

and spreading them out in thin sheets (p. 26) so that each cell can effect synaptic junctions with incoming fibers at both ends.

The non-olfactory cortex (neopallium) of mammals everywhere presents a quite different picture from the archipallium. Its neurons are typically pyramids with a big dendrite directed outward and the axon directed inward into the white matter. These cells are arranged in layers (four to ten) which differ in form and arrangement of cells and fibers in the various cortical fields. Gray (1924) has published a more detailed description of this arrangement in the cortex of the opossum than we have for any other lower mammal. Figure 14 shows the arrangement of cortical cells in the area parietalis, the somesthetic-motor field of the opossum. Here the six typical cortical layers as defined by Brodmann are obscurely evident. In higher brains, these laminae are more sharply defined and the differences between the various cortical areas are greater. In the human brain, upward of fifty such cortical areas can be distinguished. Illustrations of the more complicated cortical patterns of man are given in all of the larger manuals of neurology, and these details need not be elaborated here.

The greater thickness of the neopallial cortex and a different type of intercellular connections necessitate a cellular pattern different from that of the archipallium. The neurons are of very diverse forms and those of each of the different layers make

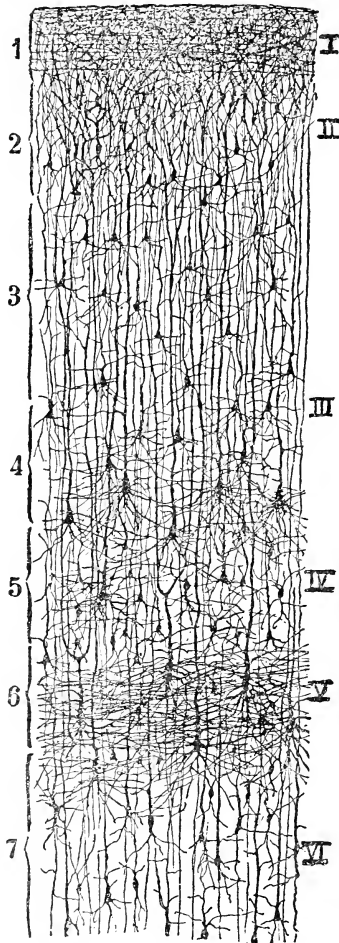

FIG. 16.—Structure of the human cerebral cortex in the postcentral gyrus, method of Golgi. After Ramón y Cajal. The cortical layers as enumerated by Cajal are indicated at the left; those of Brodmann at the right.

characteristic synaptic junctions with fibers from other parts. Figure 16 illustrates the structure of the human cortex of the postcentral gyrus (somesthetic

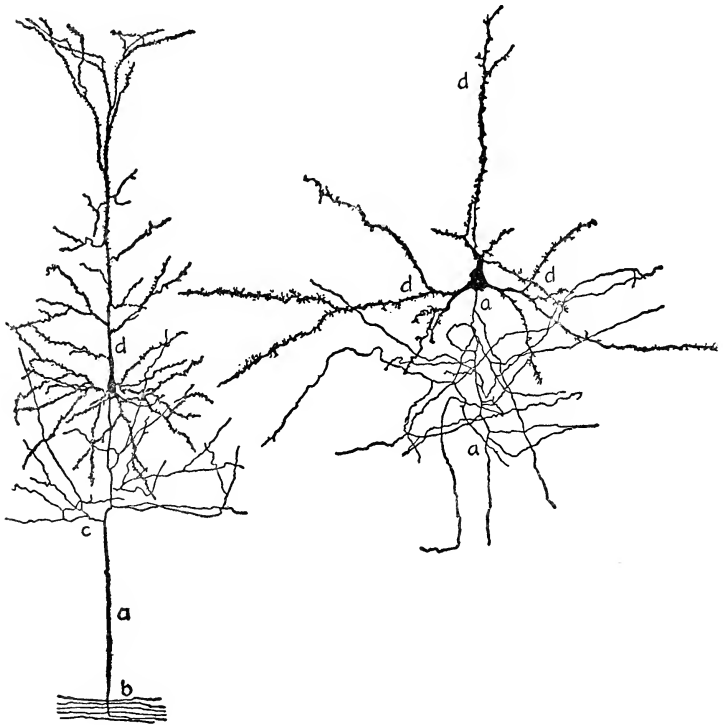

FIG. 17.—Two neurons characteristic of neopallial cortex. At the left is a pyramidal neuron (type I of Golgi) from the rabbit (after Cajal), whose axon (*a*) enters the white matter (*b*), first giving off collateral branches (*c*) to the deeper cortical layers. The larger dendrites (*d*) are directed toward the brain surface. At the right is a neuron of type II from the cat (after (Kölliker), whose short axon (*a*) branches freely and terminates close to the cell body.

field). This area is roughly comparable with the area parietalis of the opossum (Fig. 14). Comparison of the relative thickness of the layers in these two sections brings out vividly the greater development of the human supragranular cortex (layers II and III of Brodmann). This is a point of great importance in view of Bolton's (1914) belief that these layers contain the nervous mechanisms chiefly concerned with the higher individually learned cortical functions.

Figure 17 illustrates two forms of neurons which are especially characteristic of neopallial cortex. At the left is a pyramidal cell whose axon enters the underlying white matter and may connect with very remote parts of the cortex. At the right is a cell (type II of Golgi) whose short axon breaks up in the immediate vicinity of the cell body (p. 317).

The organization of the cerebral hemispheres of reptiles, birds, and mammals makes it plain that the cerebral cortex is related genetically and physiologically with the corpus striatum complex in very intimate fashion and that this relationship changes radically between the sauropsid and the mammalian types. It is impossible in the present state of our knowledge to treat this subject adequately, but its importance in the problem of cortical functions is so great that some attention must be paid to it before we can advance further.

## CHAPTER V

### CEREBRAL CORTEX AND CORPUS STRIATUM

*The odors borne by the air are the source of so many and varied forms of information or clues regarding the environment of a land animal, not only with reference to food but with reference to all its external relations, that the expansion of the pallium for correlation of tactual, visual, auditory and proprioceptive impressions with one another demands a co-ordinate development of centers for the correlation of all these with olfactory impressions. The lateral olfactory area, though it elongated pari passu with the general pallium, was not equal to this task without further development and differentiation.*

—J. B. JOHNSTON

**C**OMPARISON of the normal behavior of fishes and amphibians where both corpus striatum and cortex are rudimentary, birds where the striatum complex is enormously developed but cortex is very deficient, reptiles with large striatum and small but well-defined cortex, and mammals where the cortex is progressively amplified clearly shows that the striatum complex and thalamus are enlarged in proportion to the complexity of the innate and instinctive behavior and that the cortex is enlarged in proportion to individual initiative, docility, and inventiveness.

Attempts to control these observations experi-

mentally have so far yielded meager and confusing results. Most of the behavior of lower vertebrates is not plastic but stereotyped—either innate or habitual—and the laboratory experiments so far devised have not revealed all that we need to know regarding the relations of the cerebral cortex to behavior patterns. In fact, we have very little adequately controlled knowledge of the details of the behavior of lower vertebrates except in connection with sense physiology and trial-and-error learning. To this subject we shall return.

The beginnings of the corpus striatum can be recognized in fishes and amphibians, though very incompletely separated from adjoining parts of the fore-brain. In all reptiles the corpus striatum complex is greatly enlarged and complicated. In birds it is still larger and more complex, more so than in any other vertebrates. In view of the deficiency of cerebral cortex in birds, these are the most favorable species in which to study the functions of the corpus striatum itself.

#### BIRDS

For a century past the behavior of birds with cerebral hemispheres injured or destroyed has been assiduously studied. Upon complete removal of the hemispheres the bird is in a state of idiocy, but if the thalamus is undisturbed there is little change in the simpler reflexes. The animal at times stands

quietly in apparent stupor, at other times it is restless and keeps moving about.

Rogers (1916) has restudied these phenomena with more exact anatomical control than has usually been employed, and he concludes that this decerebrate restlessness is due to the lack of the normal inhibitions from the hemispheres acting on the lower reflex centers. Further analysis shows that it is only inhibitory reactions arising from external stimuli which are lacking; those arising from visceral internal stimuli are still operating. If the bird is kept well fed and watered the restlessness will not appear. This restlessness, in short, is correlated with hunger contractions of the digestive tract or other visceral activities. Rogers says, "When the hemispheres are gone, inhibitory reactions to external influences are gone but are still retained for intrinsic stimuli."

With injury to the thalamus there is a marked change in the behavior and interference with temperature regulation and other visceral functions. This suggests that the thalamus is more important for visceral correlations than are the cerebral hemispheres. The birds remain quiet and cannot care for themselves, starving to death in the midst of plenty unless artificially fed (Rogers, 1919). In these birds the temperature of the body fluctuates with that of the cage and at ordinary room temperatures the condition is as described above; but if the room temperature is raised so as to bring the body temperature



up to normal, the behavior changes and approaches that of a bird deprived of cerebral hemispheres but with normal thalamus.

It appears that the thalamus independently of the cerebral hemispheres (that is, when the latter have been completely removed) controls reflexes arising from painful stimulation and many of the fundamental visceral reflexes (hunger, thirst, body temperature, respiration, etc.).

Figure 18 illustrates the external form of the brain of the pigeon and Figure 19 a cross-section through the cerebral hemispheres. The striatum complex of the bird is unique in several respects: the great reduction of the olfactory component, the enormous increase in thalamic connections (both somatic and visceral), the reduction to insignificant proportions of the overlying cerebral cortex.

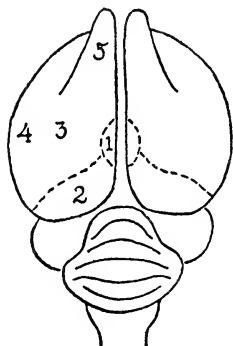

FIG. 18.—The dorsal surface of the brain of the pigeon, showing the electrically excitable areas (Rogers, 1922*a*). 1, maximum constriction of pupil of opposite eye; 2, less pupillary constriction; 3, bilateral winking; 4, opening and closing beak (from underlying ectostriatum); 5, depression of feathers of forehead and throat.

Rogers (1922) found in decerebrating pigeons that if the cores of the hemispheres (i.e., the mesostriata of Fig. 19) are left undisturbed the remainder of the

hemispheres can be removed without loss of the fundamental reflexes. Such a partially decerebrated pigeon will avoid objects in walking and flying and possesses normal eye reflexes. Though at first it cannot feed spontaneously, in the course of a few weeks it may reacquire the power of feeding itself.

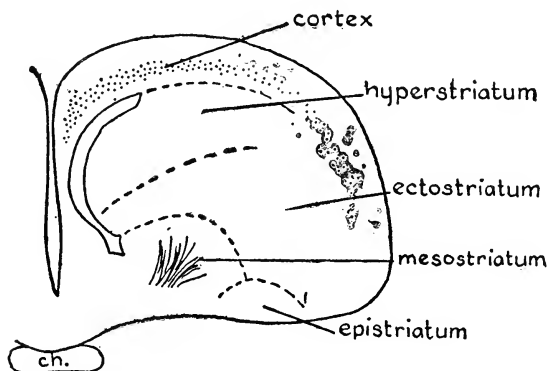

FIG. 19.—Cross-section through the right cerebral hemisphere of the pigeon with parts of the corpus striatum named after Edinger.

The elements of the mating reflexes and other complex behavior patterns are seen, but these cannot be combined in the normal reflex cycles in the absence of the ectostriatum and hyperstriatum.

Removal of the cerebral cortex alone, that is, the surface of the hemisphere to a depth of about an eighth of an inch, leaving a portion at least of every part of the striatum intact, results in little permanent modification of the behavior of the caged bird. A complete breeding cycle can be carried through. The

female may mate, lay fertile eggs, incubate them, and rear the young. In these birds there is greater tendency to a fixed type of reaction. Thus the male will give the courting and fighting reaction to any small moving object, but only while it is moving. There is no spontaneous fighting of an object or bird which is not moving. Fear reactions and efforts to escape from confinement are absent and there is no spontaneous flight of escape when the bird is unconfined by a cage. Avoiding reactions of flight can be induced by mistreatment (strong stimulation), but not by moving objects which do not touch the bird. Reactions are more readily fatigued than in the normal bird.

These observations apply to birds kept for three to six months after operation. It is concluded that physiologically the cortical part of the hemispheres is related to the production of a greater variety of reactions from a single stimulus; to the lowering of the threshold for distant stimuli; to the exercise of an augmentor effect so that the reactions are more prolonged and persistent. Apparently, the pigeon's cortex is so incompletely separated from the striatum and of so low an order of differentiation that its defect can in large part be compensated by the underlying tissue. These conclusions are significant and must be kept in mind when we come to consider the much better developed cortex of the lower mammals.

Progressive removal of the corpus striatum, from without inward, results in loss of successive phases of

the more complex instinctive cycles of mating, etc., and of evidence of intelligent behavior. The ectostriatum and mesostriatum appear to be responsible for feeding reflexes and the epistriatum for certain visual correlations. Rogers (1922) summarizes his observations in these words:

After loss of cortex and hyperstriatum there issues a long period of helplessness, but the bird may regain the ability to feed itself, but does not go through the mating or nesting cycles of behavior. It is shown that the hyperstriatal (hypopallial?) area, without the cortex, can carry out a single association or learning process involving the correlation of several different physiological reactions to form the customary behavior cycle.

Within the hemispheres there are no excitable cortical areas for skeletal muscles, though the underlying ectostriatum appears to be excitable—the one demonstrated instance being for movements of the beak as in feeding (Rogers, 1922*a*). Stimulation of the cortex itself reveals three excitable areas for visceral reactions, involving the peripheral sympathetic system (Fig. 18): vasomotor and pinnamotor effects and pupillary constriction of the opposite eye. The vasomotor and pinnamotor effects are probably expressions of a very generalized type of cortical control over thalamic functions.

The instinctive endowments of birds are very complex and their behavior appears to be highly emotional. Their intelligence, however, is not usually rated very high. When we compare the brains of reptiles, birds, and mammals we see that corpus

striatum and cerebral cortex are independent variables. When we compare the behavior of these animals we see that innate and habitual behavior patterns may be very greatly elaborated without corresponding enlargement of capacity for rapid learning by experience and intelligent types of behavior. We see that amplification of innate and stereotyped behavior goes hand-in-hand with enlargement of the thalamus and subcortical parts of the cerebral hemispheres; increase in capacity for rapid learning, memory, and individual initiative is correlated with enlargement and diversification of structure in the cerebral cortex (Herrick, 1924, pp. 211, 270).

From these observations and others that might be mentioned it is clear that in birds the apparatus serving most of the established behavior patterns lies in the thalamus and corpus striatum. The feebly developed cortex influences these behavior patterns but is not essential to most of them. The cortex is essential to the synthesis of the lower reflexes into certain types of adjustment to external events and it exerts some sort of a dynamogenic effect. Observation of decorticated birds in more varied situations than are possible in small laboratory cages would probably show greater deviations from normal behavior than appear under the conditions described. Yet these cortical influences at the most doubtless play a relatively small part in the bird's total behavior.

The birds represent a divergent line of evolution,

a terminal branch of the vertebrate genealogical tree. They are in some respects more highly specialized than any mammals, but this differentiation has taken a different direction. Their reptilian ancestors having attained a highly elaborated organization of innate or instinctive behavior with corresponding development of subcortical cerebral structure, they have not deviated from the trend of evolution thus early laid down. In accordance with the principles of irreversible differentiation or natural orthogenesis which I have elsewhere explained (1920), they have not in any case dedifferentiated their complicated tissues sufficiently to start a new direction of specialization such as we find in mammalian cortical evolution.

#### REPTILES

We know from paleontology that the ancestors of mammals were primitive reptiles or reptile-like animals whose general organization was more like that of recent turtles (except for the shell) than of any other American animal species. And the endocranial casts of early mammalian species (e.g., *Dinoceras*) are said by Elliot Smith (1910) to be "curiously reptilian-like." In the turtles the relations of the emergent cerebral cortex to underlying parts of the brain are clearly revealed.

Without going into the details of internal structure of these parts, it is evident that the thickening of the lateral wall of the hemisphere is correlated with

a broader connection between the thalamus and the hemisphere. This means in terms of behavior that reptiles make far more efficient use of their exteroceptive sense organs than do fishes or amphibians; they are more adaptable to changes in their environments. These adaptations are mostly effected by relatively fixed reflex, instinctive, and habitual behavior, but not wholly so.

In turtles the greatly thickened lateral wall of the cerebral hemisphere contains three structures which are intimately related, corpus striatum, amygdala, and pyriform cortex. The first two are subcortical structures. The pyriform cortex clothes the amygdala and seems to have differentiated out of it, at least in part. The general cortex of reptiles (forerunner of mammalian neopallium) is similarly related to the non-olfactory part of the corpus striatum. The analysis of the reptilian strio-amygdaloid complex must therefore precede a complete understanding of the rise of the cerebral cortex.

The brains of reptiles have been intensively studied by several competent neurologists and the analysis of their cerebral hemispheres is well advanced. The following discussion (pp. 102-111) must necessarily include some technical details which may not be of interest to all readers. To such the friendly hint may be given that the omission of these pages will not seriously impair the continuity of the remainder of the text.

The reptilian cerebral hemisphere includes in front the large olfactory bulb, into which the olfactory nerve discharges directly from the nasal epithelium. Immediately behind this is a field of reflex correlation dominated by the fibers of the olfactory tracts coming from the bulb, the olfactory nucleus. The ventromedial wall is the septum, a center of olfactory, gustatory, and visceral correlation. The massive ventrolateral wall contains the corpus striatum and amygdala, both of which are very complex internally. The striatum complex includes a number of structures which can be recognized as the precursors of the mammalian globus pallidus, putamen and caudate nucleus, though these parts are not assembled in the mammalian pattern. The amygdala lies posteriorly of the striatum and is very large and complicated in reptiles and lower mammals, though in man it is reduced to a small gray nucleus under the temporal lobe of the hemisphere. These are all subcortical structures. The dorsal convexity is occupied by the three cortical sheets to which reference has already been made. The relations of these parts in the brain of the turtle will be described in some detail, following in the main the studies of Johnston (1915, 1923).

Figures 20-24 are outlined from Johnston's figures, but the names applied to the parts are in some cases changed in conformity with the present text. In reading the literature of fore-brain structure of lower vertebrates it must be borne in mind that the terms corpus striatum, epistriatum, paleostriatum, archistriatum, neostriatum, hypopallium, etc., are used in different senses by various authors and that all of these usages are based on inadequate knowledge of the actual functional connections of the parts in question. Some parts of the forebrain can be recognized from fishes to mammals without fundamental change; other parts are profoundly modified, and the application of mammalian names to these latter parts is apt to be confusing.

For purposes of orientation we may first sketch in outline the probable history of the evolution of the strio-amygdaloid complex in vertebrates.



Primitively, as in cyclostome fishes, all of the endbrain (telencephalon) probably received olfactory fibers, with the exception of a small field (the "somatic area" of Johnston or "striatum" of current descriptions of cyclostomes) adjacent to the thalamus. This so-called striatum also receives fibers from olfactory correlation centers, though not directly from the olfactory bulb, and throughout the fishes the corresponding field is broadly connected by ascending and descending fibers with the thalamus. This field may be called the "primordial striatum."

In most fishes and in the lower Amphibia the primordial striatum is very imperfectly separated from the adjacent secondary olfactory nuclei. It is included within the somatic and olfacto-somatic areas of my analysis (1922*a*). In the dogfish and the frog it is tolerably clearly subdivided into two parts: First, there is the somatic striatum, whose dominant ascending and descending connections (exteroceptive in function) are with the thalamus, but which also receives correlation fibers from olfactory centers of the hemisphere. This is the "somatic area" of Johnston, the precursor of the lentiform nucleus. Second, there is a complex which serves correlations of olfactory nervous impulses with those of taste, general visceral sensibility and others, the olfacto-striatum and primitive amygdala. This was originally differentiated within the lateral olfactory nucleus under the influence of fibers ascending from the hypothalamus and thalamus. This complex is under strong olfactory influence throughout the vertebrate series; in mammals it becomes part of the caudate nucleus and part also of the amygdala.

In reptiles Johnston in 1923 called the olfacto-striatum the "bed nucleus of the stria terminalis." It is the deepest part of the striatum complex (Figs. 21, 22, 23), extending nearly the whole length of the hemisphere close to the ventricle and terminating behind in the highly differentiated primitive amygdala (Fig. 24). The somatic striatum, or lentiform nucleus, lies more laterally and is clearly separated into putamen (an afferent center, Figs. 20, 22, 23) and globus pallidus (an efferent center, Fig.

23). The parts so far listed comprise the old striatum of reptiles. To these there is added a new structure which Johnston at first

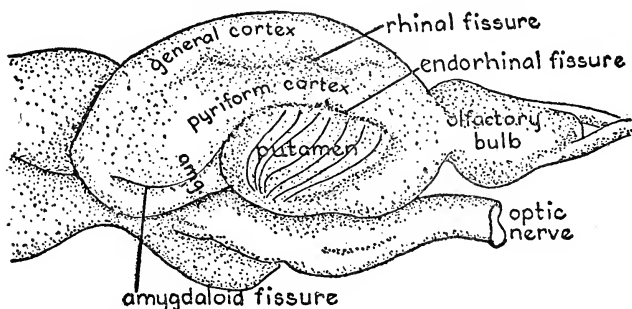

FIG. 20.—Lateral aspect of the cerebral hemisphere of the box-tortoise, *Cistudo*. The amygdala (*amg.*) is partly covered by pyriform cortex. Figs. 20-24 are based on drawings by Johnston (1915).

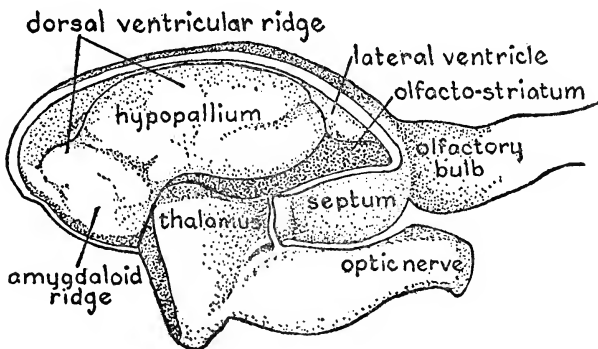

FIG. 21.—The lateral wall of the cerebral hemisphere of the box-tortoise dissected off and viewed from the ventricular surface, to illustrate the dorsal ventricular ridge and its subdivisions.

(1915) called the "dorsal ventricular ridge" (Fig. 21) and Elliot Smith (1919, 1919a) called "hypopallium," to be described more in detail presently.

Figure 20 shows a lateral view of the cerebral hemisphere of the box-tortoise. The corpus striatum (putamen) is superficial laterally (in mammals this is covered by cortex). Part of the amygdala is superficial, though most of it is covered by the pyriform cortex, which is bounded above and below by the rhinal and endorhinal fissures. If the lateral wall of the hemisphere is

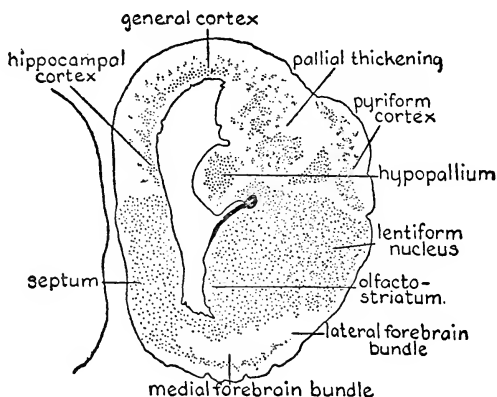

FIG. 22.—Cross-section through the anterior part of the cerebral hemisphere of the box-tortoise.

dissected off and examined from the ventricular surface, the appearance is as shown in Figure 21. Figures 22-24 show cross-sections through the anterior, middle, and posterior parts of the hemisphere, respectively (cf. Fig. 10, p. 76).

Internally of the putamen is the globus pallidus (Figs. 20, 23) and internally of both of these is the olfacto-striatum (Figs. 21, 22, 23). These comprise the old striatum, directly derived from the striatum of Ichthyopsida. Above these is the "dorsal ventricular ridge," a new structure which is not represented at all in fishes and amphibians. The whole of this was called "hypopallium" by Elliot Smith because its relations are more

intimate with the overlying pallial field than with the underlying striatum.

Johnston (1923) has pointed out that this dorsal ventricular ridge consists of two parts which are dissimilar in origin, in function, and in their definitive arrangement in the mammalian brain.

(1) The anterior part (hypopallium of Figs. 21, 22, 23) is ana-

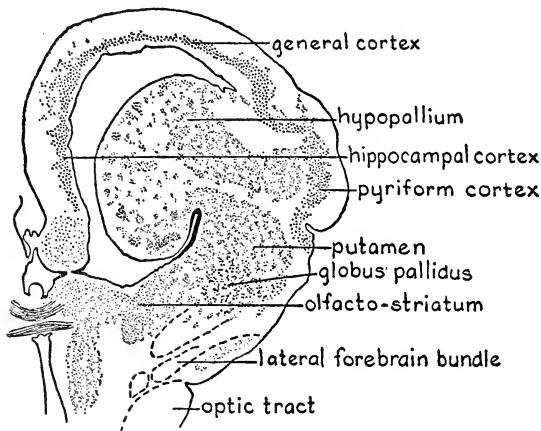

FIG. 23.—Cross-section through the middle of the cerebral hemisphere of the box-tortoise.

tomically and physiologically closely related with the overlying general cortex above the rhinal fissure. The “pallial thickening” of Figures 22 and 23 is a transitional sheet of cells interposed between the general cortex and the hypopallium. (2) The posterior part (amygdaloid ridge of Figs. 21 and 24) is similarly related with the pyriform cortex along the line of the amygdaloid fissure which is a backward extension of the endorhinal fissure. It is added to the older primitive amygdala which lies ventrally of it. Johnston calls the anterior part of the dorsal ventricular ridge “caudate nucleus”; but this is confusing because the definitive

caudate nucleus of mammals includes both this structure and the older olfacto-striatum (his "bed nucleus of the stria terminalis"). I have, accordingly, retained Elliot Smith's very appropriate name, "hypopallium," for the anterior end of the dorsal ventricular ridge, and for the posterior end of this ridge I adopt Johnston's term (1923, p. 461), "amygdaloid ridge."

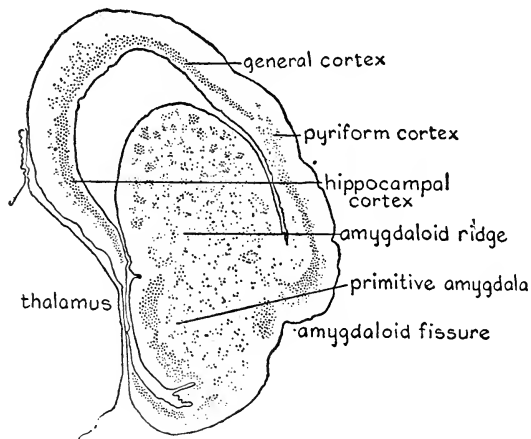

FIG. 24.—Cross-section through the posterior part of the cerebral hemisphere of the box-tortoise.

Johnston (1916a) describes the development of the dorsal ventricular ridge in turtles and states that the hypopallium of my usage here is derived by ingrowth from the lateral margin of the general cortex and that the amygdaloid ridge is similarly infolded from the pyriform cortex. Hines (1923) has given an account of the development of the corpus striatum complex in the generalized reptile, *Sphenodon*, which differs in some respects from Johnston's description of the turtle. The hypopallium is not infolded from the lateral margin of the general cortex but is developed *in situ* in a neostriatal ridge. The amygdaloid ridge

similarly is differentiated *in situ* and not infolded from the ventral margin of the pyriform cortex. The end result, however, in the adult brain of *Sphenodon* is substantially the same as in the turtle.

Quite apart from questions of embryological development of these parts, it seems clear that in adult reptilian brains the hypopallium is transitional tissue between the older part of the corpus striatum and the neopallium and that the amygdaloid ridge is transitional between the primitive amygdala and the differentiated pyriform cortex. With further development of these cortical sheets in mammals, the dorsal ventricular ridge loses its anatomical separateness. In embryonic mammals (Hines, 1922) the reptilian form of corpus striatum complex is repeated almost exactly, but in the adult the anterior end of the dorsal ventricular ridge (hypopallium) is joined to the olfacto-striatum to form the caudate nucleus and its posterior end (amygdaloid ridge) is joined to the amygdala. The lentiform nucleus (putamen and globus pallidus) is separated from the caudate nucleus by internal capsule fibers.

In birds the hypopallium is probably represented in the hyperstriatum (Fig. 19, p. 96) which Kappers (1923) has shown is derived embryologically from pallial territory and which performs functions closely related with those of the cerebral cortex.

From the preceding account it follows that the human caudate nucleus is a mixture of elements of two very diverse sorts: (1) a very ancient olfacto-striatum, primitively developed within the lateral olfactory nucleus; and (2) beginning with reptiles the addition of other elements from a non-olfactory field more intimately related with the neopallium. The amygdala has a somewhat similar history. Primitively developed within the caudal end of the lateral olfactory nucleus, there are added to it in reptiles other elements from a field intimately related with the pyriform cortex which is now highly differentiated. In the human caudate and amygdala the non-olfactory functions clearly pre-

dominate, though the primitive olfactory component is not entirely lost.

The history of the development of the corpus striatum complex may be summarized as follows:

1. In the lowest vertebrates there is a *primordial striatum* dominated by thalamic connections and directly or indirectly connected with adjacent olfactory nuclei. In many fishes and lower Amphibia this primordial striatum is incompletely separated from the olfactory nuclei.

2. In the dogfish and frog there may be recognized within the striatal field a *somatic striatum* (precursor of the lentiform nucleus) with well-defined thalamic connections, and an olfacto-strio-amygdaloid complex which is incompletely separated from the lateral olfactory nucleus and primordial pyriform lobe.

3. In reptiles the *somatic striatum*, *olfacto-striatum*, *primitive amygdala*, and *pyriform cortex* are separately differentiated, and there is added a new structure, the "dorsal ventricular ridge" of Johnston, whose rostral end, the *hypopallium*, is apparently related anatomically and physiologically with the overlying neopallial cortical field and whose caudal end, the *amygdaloid ridge*, is similarly related with the pyriform cortex.

4. In mammals the hypopallium is added to the olfacto-striatum to form the *caudate nucleus*; the amygdaloid ridge is incorporated into the *amygdala*. The *lentiform nucleus* is the persistent somatic striatum somewhat further differentiated. From reptiles onward the somatic striatum is clearly separated into the two parts which together comprise the lentiform nucleus: (1) an afferent part, the *putamen*, and (2) an efferent part, the *globus pallidus*.

5. The *globus pallidus* is the common efferent center for a large part of the striatum complex and its large motor cells can be recognized as far down as the fishes, mingled with other cells of the somatic striatum. The *globus pallidus* is primarily the efferent nucleus of the somatic striatum, but by reason of the

voluminous intrinsic connections of all parts of the striatum complex it serves as efferent path for part of the caudate activities also.

The efferent fibers from the globus pallidus go downward in a large and complex strand of fibers known as the lateral fore-brain bundle, which is the precursor of the internal capsule system of mammals. In lower mammals (and probably in reptiles) efferent fibers also leave large cells of motor type in the ventral

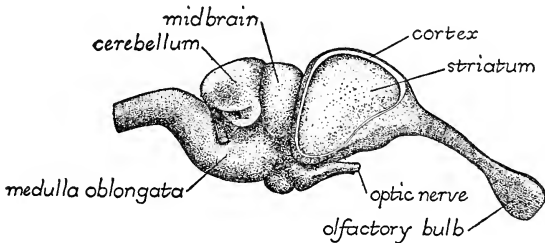

FIG. 25.—The brain of a young alligator 55 cm. long as seen from the right side, one and one-half times natural size. The lateral cerebral cortex has been removed, opening the lateral ventricle and exposing the underlying corpus striatum complex. Redrawn from Crosby (1917).

part of the head of the caudate nucleus (olfacto-striatum). These go downward in the medial forebrain bundle. There is a third and very large efferent tract passing down in the medial forebrain bundle from the amygdala and pyriform lobe, the olfactory projection tract of Cajal. All parts of the strio-amygdaloid complex are intimately connected by short intrinsic fibers, and the pathway taken by the efferent discharge from this complex in any reaction is probably determined by the particular motor organs to be innervated.

In lizards and serpents the arrangements described for turtles are considerably modified and complicated, but into these details we need not here enter. In crocodiles the hemispheres are further



enlarged (Fig. 25). The striatum complex approaches that of birds and the cortex is more extensive than in other reptiles (Crosby, 1917).

Johnston (1916) found that the cerebral hemisphere of the turtle is electrically excitable, but in the light of the later experiments of Koppányi and Percy (1925) it is uncertain whether this

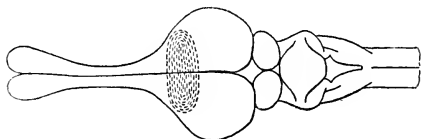

FIG. 26.—Dorsal view of the brain of the alligator. The shaded area marks the electrically excitable field. After Bagley and Richter (1924).

is a cortical response or from the underlying corpus striatum. In the alligator electrical stimulation of the area shaded in Figure 26 (Bagley and Richter, 1924) produced various general movements of the body and limbs, but it was not possible to produce movements of the individual extremities. Here again we are somewhat in doubt about the particular cells which were stimulated, whether truly cortical or subcortical.

The corpus striatum of mammals is generally said to be electrically inexcitable, but recent studies show that in some lower species (opossum, Rogers, 1924) this is not true. This is further evidence that in lower mammals the physiological relations between cortex and corpus striatum are more intimate than in higher forms.

## CHAPTER VI

### CORPUS STRIATUM OF MAMMALS

*There are, as I look at it, only two roads which can lead to the understanding of the structure of the brain, though these have been but little travelled up till now. These two roads are comparative anatomy and the anatomy of the foetus, which should guide us here like a veritable thread of Ariadne.*

—F. TIEDEMANN

**B**IRDS in diverging from ancestral reptiles developed the hypopallium to the extreme without corresponding elaboration of the cortex; in fact, the cortex of birds appears to be actually regressive as compared with any existing reptiles. In mammals, on the other hand, the cortex undergoes extensive differentiation and the lowest living mammals have far more extensive and complex cortex than any reptiles, while the corpus striatum remains relatively small as compared with reptiles and birds. The striatum complex also assumes a form different from that of any reptiles, and as the mammalian series is ascended it becomes progressively more completely detached from surrounding structures. The striatum complex of lower mammals consists of the following parts (Fig. 27):

1. Laterally and posteriorly in the temporal lobe there are the amygdaloid nuclei which receive part of the great lateral olfactory tract and ascending fibers

from the hypothalamus and thalamus and which discharge fibers through the olfactory projection tract of Cajal into the motor centers of the hypothalamus and cerebral peduncle. They probably serve chiefly higher correlations of smell, taste, and somesthetic sensibility for feeding and visceral reflexes.

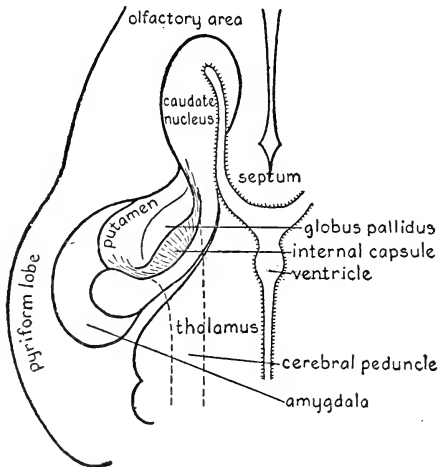

FIG. 27.—Diagram of the corpus striatum and amygdala of a lower mammal as seen in horizontal section.

2. Medially there is the olfacto-striatum (part of the caudate nucleus) which borders the lateral ventricle for almost its entire length from far in front into the temporal lobe. It receives fibers directly or indirectly from the olfactory bulb and also fibers from the somatic sensory centers of the thalamus. Its efferent fibers go in part to the globus pallidus and thence to the cerebral peduncle, and in part they go

out directly into the medial forebrain bundle. This region probably serves for the correlation of olfactory with tactual and other exteroceptive stimuli and may be concerned chiefly with locomotor and facial reflexes involved in feeding.

The first and second components of the striatum complex are much more extensive in lower mammals than in higher. Between and above them is a third component which is also very ancient.

3. The nucleus lentiformis, or somatic striatum, receives no olfactory fibers, but large tracts which ascend from the exteroceptive and proprioceptive centers of the thalamus. It consists of a receptive part (primitive putamen) and an emissive part (globus pallidus) of large cells whose axons descend by way of the internal capsule (lateral forebrain bundle) to the motor centers of the cerebral peduncle.

4. To these ancient parts there is added in reptiles, birds, and mammals a new striatum which is incorporated into the older caudate and lentiform nuclei—the hypopallium of the preceding description. This is related physiologically with pallial territory and has very different significance from other parts of the striatum complex.

This new striatum is an anatomically distinct structure in adult reptiles and mammalian embryos. It is the hypopallium of reptiles, in the restricted sense in which I use the term, the “nucleus caudatus” of Johnston’s account (1923) of reptiles and embry-

onic mammals, and the corpus striatum laterale of Hines's figures (1922) of the developing human brain. In adult mammals the new striatum loses its identity as a separate lobe of the striatum. Most of its tissue is joined to that of the olfacto-striatum (bed nucleus of stria terminalis of Johnston, 1923) to form the definitive caudate nucleus, and a smaller part is contributed to the putamen and claustrum.

The functions of the new striatum of lower mammals have not been clarified. In reptiles and birds the corresponding structures are evidently transitional, both anatomically and physiologically, between the old striatum and the cerebral cortex. This transitional hypopallium and the related cerebral cortex exert some sort of reinforcement or augmentation upon some behavior sequences and some measure of inhibition upon other sequences. They are also concerned with the synthesis of elementary reflexes into more complex instinctive cycles and with increase in the range and variety of reactions to exteroceptive stimulation (Rogers). With amplification of the cortex in lower mammals the second group of these functions seems to have been taken over wholly by the cortex and the first in part. The more intimate fusion of the new striatum with the old striatum results in a complex organ whose functions seem to be predominantly dynamogenic.

There is some evidence that the mammalian striatum exerts some control over various visceral

activities (for summary see Kappers, 1921, pp. 1090-1092) and feeding movements (Dresel, 1924), but its chief activities center about control of the skeletal muscles, their tonicity, steadiness, and co-ordinated action in mass reflexes (Wilson, 1912; Vogt, 1920).

In all mammals the globus pallidus retains its ancestral character with but little change. In lower mammals the olfacto-striatum and amygdaloid complexes have as highly developed olfactory components as in any reptiles—perhaps more so—and there is great increase in the number and complexity of their thalamic connections. The hypopallium is structurally reduced, and its functions seem to have been in part taken over by the rapidly expanding cortex.

In marsupials, unlike higher mammals, the corpus striatum is electrically excitable (Rogers, 1924). There is also motor cortex far forward in the cerebral hemispheres and an incompletely developed pyramidal tract (for head and fore limb control only) extending to the upper level of the spinal cord. Cortical control of head and fore-limb movements is very incomplete, and destruction of the motor cortex gives slight and transient motor disturbances of only the finer arm movements. Destruction of both motor cortex and underlying striatum gives in addition to phasic disorders of movement, spastic contraction of the fingers, tonic twisting of the neck toward the operated side, and other symptoms of the striatal syndrome. These observations again illustrate the

incomplete differentiation of cortical and striatal mechanisms of control of behavior in these primitive mammals.

That the corpus striatum is essential for the performance of all but the simplest reflexes in lower mammals and indeed in species as highly organized as the dog is indicated by the following experiments.

In most of the decerebrate dogs described in the literature some portion of the striatum was preserved. In Rothmann's case (1923) the dog after a time recovered a considerable number of rather complex functions. He would seek food, avoid obstacles, and in general behave like a dog deprived of his higher sense organs.

In one of Rogers' opossums (1924) the cortex was almost completely destroyed except for a portion of the olfactory field and there was extensive injury to the corpus striatum of both sides, though this was not all removed. Eleven days after the operation the animal showed decerebrate restlessness interrupted by periods of profound stupor. There was no motor paralysis. It seemed to be completely blind, and was unable to avoid obstacles except by the sense of touch. To cutaneous stimuli it gave the ordinary avoiding reactions. It would eat and drink if food and water were put in contact with the lips but it never sought food. The picture in general was that of profound imbecility, depression, and loss of certain inhibitions.

Dresel (1924) succeeded in removing the whole of the cortex and corpora striata from a dog which lived for three months thereafter. The animal can stand and walk, but it does not do so spontaneously, only under stimulation, external or internal. Generally it lies quiet, but becomes restless if the bladder is full, if hungry, or if stimulated. Then it arises and runs around with depressed head. It runs into every obstacle, avoiding nothing, and gradually comes to rest standing, or it falls down and remains lying until a new stimulus excites it. It lacks all spontaneity. In general, the animal until death learned absolutely nothing. On the other hand, one has the impression that the dog becomes more demented, while Rothmann's dog from day to day showed advance in his behavior so that finally he was competent to perform complex reflexes and (apparently) the lower psychic adjustments. Rothmann's dog would seek his food. But this dog as long as he lived had to be fed by hand. Solid food had to be thrust well down into the pharynx. He never reacted to food put in contact with his muzzle differently from other objects. He differed from Rothmann's dog also in lacking normal adjustment of the body and its members in space, capacity for executing isolated movements, feeling of time, the normal paroxysms of rage, and the normal alternation of sleep and wakefulness. Upon application of a painful stimulus Rothmann's dog would snap at the place irritated. This dog never did so,



but would leap blindly away—forward if stimulated on the tail, backward if on the nose, and to the opposite side if on the side of the head—often continuing until he hit the side of the room. He showed only the most primitive avoiding reactions. There was a striking poverty of movement and the retention of postures which in a normal animal would be corrected. At no time after the operation did the dog show Wilson's disease, paralysis agitans, or muscular rigidity, symptoms usually associated with striatal disease in man. The author concludes that, while a dog lacking the cortex can perform complex movements because the striatum apparently replaces in part the cortical functions, if the striatum also is lost there is no longer capacity to combine simple movements into more complex patterns.

These observations seem to show that in mammals the corpus striatum (or at least a part of it) is essential for the performance of all more complex adjustments, even those which in still lower animals may be mediated by the thalamus. But they do not make plain just what rôle it plays. The fact that partial and unsymmetrical injuries to the striatum cause circus movements, motor inco-ordination, tremor, and rigidity suggests that the influence of the striatum is chiefly (perhaps wholly in higher mammals) dynamogenic.

It is clear that as we pass from lower to higher mammals the relations of the corpus striatum to the

cortex are changed. In man more precise clinico-pathological analysis is rapidly yielding results which can be interpreted, at least provisionally, in terms of normal functions. In man the olfactory component of both striatal and amygdaloid complexes is greatly reduced, with increase in the thalamic components. The afferent thalamic fibers distribute to both caudate nucleus and putamen, coming by way of the ansa lenticularis and internal capsule. The chief efferent path from these parts of the striatum is to the globus pallidus, which in turn sends strong tracts into the lower motor centers, particularly the subthalamus and motor tegmentum of the midbrain.

Recent students of the human corpus striatum are inclined to deny any direct anatomical connection between the cortex and the striatum, but certainly these parts are in intimate physiological relations somehow. One experimental study (Grünstein, 1924) has demonstrated in the dog a direct path from the frontal cortex to the globus pallidus. There are probably some cortico-striatal connections in man.

Kinnier Wilson (1924) brings out important differences between movements evoked by electrical stimulation of the cortex and those evoked by stimulation of centers lying below the thalamus. The former are phasic, that is, they endure only during stimulation. But stimulation of the midbrain (except its pyramidal tract) produces postural movements which endure long after cessation of the stimulus. The pos-

tural attitudes assumed by animals which have been decerebrated just in front of the midbrain are immediately abolished by stimulation of the pyramidal tract. The motor control exerted by the thalamus seems to be essentially similar to that of the midbrain and lower centers; that exerted by the cortex is an intentional control (phasic) and its motor path (the pyramidal tract) is electrically excitable throughout its entire extent. The motor control exerted by the corpus striatum of higher animals is of still different type. Here the striatum itself is electrically inexcitable and (according to Wilson) it is "concerned more with tone control, with steadiness of innervation, than with actual origination of it."

Wilson says, "The cardinal features of disease of the corpus striatum may be summed up in three words—variability in muscle tonus, the appearance of involuntary movements, and the absence of paralysis." And again, "Relation of the corpus striatum to the rest of the old motor system is one of tone control, and of steadiness of innervation. Remove its influence by disease, and cerebello-mesencephalo-spinal motor mechanisms come into overaction in spite of the normal activity of the pyramidal system." "The normal cortico-spinal system is unable to prevent the effects of striatal disease from making their appearance. Though we speak of it as the 'last word' in motor control, it cannot inhibit the hyper-tonia and hyperkinesis of striatal disease." It should

be noted that the effects here mentioned result from destructive lesions of the striatum, releasing other centers from striatal control.

This conception of striatal functions in higher mammals appears to be in marked contrast with the conditions in birds and also in marsupials. Apparently, in higher mammals progressively more of the phasic striatal functions are transferred to the cortex, and the striatum becomes more and more an ancillary mechanism to cortically originated acts. It is significant that in so lowly an animal as the mouse Cajal found collaterals from pyramidal tract fibers entering the corpus striatum.

That the cortex does exercise a real physiological control over mesencephalic and still lower centers is shown by experiments of Graham Brown (cited by Wilson) that postural after-discharge activity from mesencephalic stimulation is immediately wiped out by stimulation of the pyramidal tract. "Non-postural cerebral activity seems to abolish postural midbrain activity." In lower mammals the cortex may have a similar relation to striatal activity; in higher mammals the striatum seems incapable of initiating even postural activity without cortical participation (in the normal).

We conclude that parallel with the elaboration of the cortex, and particularly of the motor cortex and pyramidal tract, there is a progressive change in the functions served by the corpus striatum; many of

the adjustments which in reptiles and birds are controlled from the striatum are in mammals taken up by the cerebral cortex and there further amplified. The mammalian striatum, accordingly, seems to be a relict of a much more diversified organ, preserving important but very sharply circumscribed functions.

A resurvey of the entire question of the relations of corpus striatum and cerebral cortex clearly shows that the physiological factors chiefly responsible for cortical differentiation in reptiles are to be sought in the enlargement of the thalamic radiations and the associated increase in the subcortical masses in the lateral wall of the hemisphere, or otherwise expressed in the larger participation of the hemisphere in the exteroceptive reactions of the animal. The behavior of the reptile in relation to the events taking place in the world in which he lives is controlled from the cerebral hemispheres in larger measure than in any lower species. This control is partly effected in the subcortical thickenings and partly in the cortex itself, and the directions taken in the further differentiation of the cerebral hemispheres in various species of reptiles, birds, and mammals are determined in accordance with the relative parts played by these two factors.

It has already been pointed out that when differentiated cortex first appears, in reptiles, it emerges simultaneously in three functionally diverse fields, on the medial, lateral, and dorsal aspects of the hemi-

sphere wall, and that this specialization is correlated with the increase in the thalamic radiations and with enlargement and more sharp localization of functions in the thalamus. That this increase in the participation of thalamic functions in the hemisphere is not solely responsible for cortical differentiation is shown by the fact that the first cortex does not appear exclusively in the field which receives the largest inflow of thalamic influences, that is, in the "general cortex" of the dorsal convexity, but it appears simultaneously also in the olfactory areas medially and laterally of this field, that is, in the hippocampal and pyriform fields. This evidently means that the *sine qua non* for cortical differentiation is an intimate connection by means of association fibers within the hemisphere between several fields, each of which is already a tolerably complex center of correlation with different functional connections from all of the others. And the correlation centers in question must be partially or wholly withdrawn from the main lines of direct reflex connection, so that they are not dominated by the innate stereotyped behavior patterns.

The latter point is well illustrated by the history of the further differentiation of these cortical fields in mammals. The hippocampal and neopallial cortical fields of mammals are detached in space and isolated physiologically from the main thoroughfares employed by the simpler reflexes of the brain stem, and they undergo extreme differentiation of histo-

logical patterns and functional specificity. On the other hand, the pyriform cortex, as has already been pointed out (p. 26), is always much more closely related with the large and very ancient olfactory reflex paths from the lateral olfactory nucleus, and this cortex never attains the grade of structural differentiation seen in the hippocampal and neopallial fields. Moreover, in lower mammals within the pyriform lobe itself the complexity of cortical pattern is progressively simplified as we pass from its posterior end (which closely resembles neopallial cortex) toward the olfactory bulb, and this simplification goes hand-in-hand with increase in the number of fibers received directly from the olfactory bulb through the lateral olfactory tract (Herrick, 1924*b*).

When these conditions of anatomical and physiological detachment from the simpler reflex circuits are fulfilled, differentiated cortex appears simultaneously in each of the several correlation centers so related, and the intrinsic connections of these centers among themselves permit types of association between the more elementary behavior patterns which otherwise are impossible. In the simple cortex of reptiles there is no clear-cut separation of projection centers from association centers. The projection centers are foreshadowed in the pattern of subcortical connections of the three separate cortical sheets, for this pattern is different in hippocampus, general cortex and pyriform lobe; but the associations appear

to be effected for the most part by the same neurons which receive the incoming sensory radiations. As seen in Figure 15*A* (p. 86), the axons of these neurons divide and their branches may distribute to widely separate cortical fields.

The attempt has been made in the past to define cerebral cortex in terms of the number of synapses that intervene between the peripheral receptive surfaces and the cortex, or the number of times the afferent nervous impulses have been interrupted and subjected to subcortical modification through the influence of other sensory systems in subcortical correlation centers. But this criterion is of small value, as appears from an examination of the pyriform cortex which, as we have just seen, is structurally well differentiated in extensive territories which are reached by secondary fibers of the lateral olfactory tract directly from the olfactory bulb. And I have recently demonstrated a similar relation to the medial olfactory tract in the case of the most anterior part of the hippocampal cortex in the opossum (1924*b*). It is clear that in these cases, notwithstanding direct connection with the olfactory bulb, the olfactory function is one member only of a very complex system and the association fibers from other cortical fields play at least an equal rôle, so that this tissue can perform true cortical functions in addition, perhaps, to cortical reflexes of much simpler physiological type.

In the higher reptiles, as in the alligator (Crosby,



1917), both the subcortical strio-amygdaloid complex and the cerebral cortex are more extensive than in the turtles and the behavior shows corresponding increase in complexity of both innate instinctive and more plastic or modifiable types. In birds, as we have seen, the subcortical structures are enormously hypertrophied and the cortical sheets are actually reduced; and the behavior again exhibits the correlated increment of complexity of instincts. In mammals, on the other hand, the subcortical or basal structures are relatively reduced and the cortex is progressively elaborated parallel with the rise of intelligent types of adjustment.

## CHAPTER VII

### THE THALAMUS

*Under normal circumstances the thalamic element in contact sensibility rarely, if ever, reaches consciousness, which is dominated by discriminative sensations of touch, and it only becomes a conscious factor in sensation when the influence of the cortex is removed. Thus, we believe that the essential organ of the optic thalamus is the centre of consciousness for certain elements of sensation. It responds to all stimuli capable of evoking either pleasure or discomfort, or consciousness of a change in state.*

—HENRY HEAD

**T**WO dominant physiological factors have cooperated in the phylogenetic differentiation of the cerebral hemispheres. The first is the inflow of nervous impulses from the olfactory organs in front; the second is the ingrowth from lower sensory centers of nerve fibers conducting various other systems of sensory nervous impulses. The configuration of both the thalamus and the cerebral hemispheres of the several vertebrate types has been determined largely by the interaction of these functional influences which are discharged into them from opposite directions.

Primitively, the vertebrate brain was probably a cylindrical tube with walls unequally thickened in different regions, comparable with that seen in adult *Amphioxus* or in an early embryonic stage of any

vertebrate. The manifold diversities of cerebral organization presented by the various species of vertebrates have all been derived from this simple form by unequal growth and internal differentiation of the walls of this neural tube. Many factors have co-operated, chief of which is the type of functional inter-connection of nerve centers demanded by the action systems of the several species.

In the forebrain a very early stage in this history is shown in the brain of the sturgeon (Fig. 28). In this fish the parts of the primitive neural tube into which the olfactory nerves enter are thickened and ballooned outward or evaginated to form the olfactory bulbs, and the contiguous parts of the lateral walls are locally thickened without evagination to form the primitive endbrain (telencephalon medium). The structural plan of this brain is very simple. The thickenings which form the primitive endbrain contain the nerve centers within which olfactory influences coming in from in front are correlated with non-olfactory sensory impulses coming in from behind, in conformity with the behavior pattern of this fish.

The thalamus is the narrowest part of this brain, and the fibers which ascend from it into the endbrain are few in number. A view of the under surface of this brain would show a much larger hypothalamus. These two parts, together with a small epithalamus, make up the betweenbrain or diencephalon in this

and all other vertebrate brains. In the sturgeon much larger and more important fiber systems ascend into the endbrain from the hypothalamus than from the

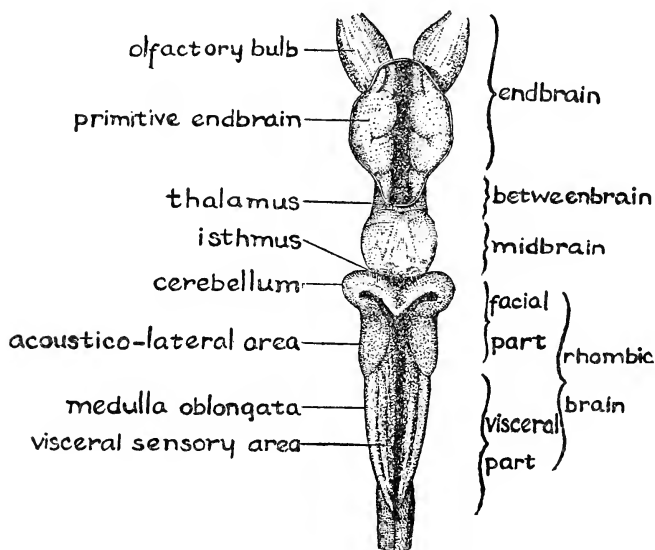

FIG. 28.—Dorsal view of the brain of the sturgeon, *Acipenser*, natural size. Membranous portions of the roof of the endbrain, betweenbrain, and medulla oblongata have been removed, opening the ventricles. Redrawn from Johnston.

thalamus. Since the hypothalamus is concerned largely with smell, taste, and visceral adjustments, this means that in this fish (as in fishes generally) the primitive endbrain is largely devoted to correlation of olfactory with gustatory and visceral activities. By far the most important centers of adjustment of the

behavior to exteroceptive (optic, auditory, somesthetic) stimuli here lie in the midbrain.

The forms of forebrain exhibited by various groups of fishes are exceedingly diverse and most of these occupy terminal branches of a widely spread genealogical tree; they do not directly lead up to any still higher vertebrate types. Into the details of the ramifications of this ancient phylum we need not enter here.<sup>1</sup>

As we pass from fishes to higher animals the thalamic centers are enlarged and complicated and the side walls of the primitive endbrain evaginate or buckle outward to form the cerebral hemispheres which undergo parallel enlargement and differentiation. The more complex life of land animals demands better machinery of exteroceptive adjustment than can be accommodated in the midbrain.

In all of these cases the configuration and internal structure of the forebrain have been molded to a large extent by the interaction within this territory of descending olfactory and ascending non-olfactory systems of nervous conduction and the elaboration of the nervous apparatus of correlation among these diverse functional systems in the fabrication of the behavior patterns characteristic of the different species.

Broadly speaking, in lower vertebrates fibers from

<sup>1</sup> The phylogenetic relationships of fishes and of their forebrains in particular have recently been discussed by several authors, e.g., Holmgren (1922), Johnston (1923), Herrick (1921, 1922a, 1924).

the olfactory bulb (directly or indirectly) pervade the medial walls of the cerebral hemispheres and most of the lateral walls except for an area of variable size, the somatic striatum, which seems to receive somatic fibers exclusively. In higher forms the margins of the cerebral cortex (archipallium) have strong olfactory connections. The dorsal cortex (neopallium), on the other hand, is dominated by its thalamic connections. The olfactory field (both cortical and subcortical) also receives numerous ascending fibers of various non-olfactory systems from the betweenbrain (thalamus and hypothalamus).

In all fishes and amphibians the general plan of the forebrain is as indicated very crudely in the accompanying diagram (Fig. 29), where a few only of the chief afferent fiber systems are sketched in. In front the olfactory nerve enters the olfactory bulb from the peripheral sense organ. This primary olfactory center is physiologically on the same plane as the sensory terminal nuclei of the peripheral nerves of the medulla oblongata and spinal cord. Farther back the optic nerve similarly connects with the roof of the midbrain, giving some collateral branches on the way to the thalamus. Still farther back the remaining sensory systems enter the medulla oblongata and spinal cord. All of these primary sensory centers are connected fore-and-aft in very intricate patterns by correlating fibers (only a few of which are shown in the diagram) of the sort already considered (p. 39).

These fiber tracts mediate an elementary but very efficient form of reflex correlation without the aid of specially differentiated correlation centers, as previously explained.

In this scheme there are four regions where correlations of a tolerably complex sort are effected: (1)

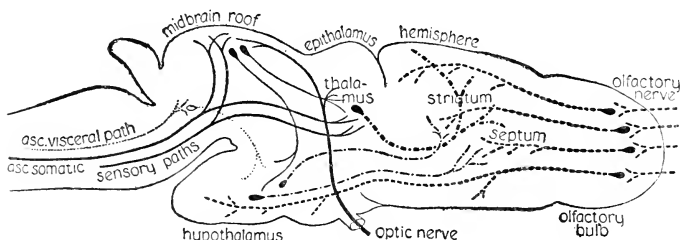

FIG. 29.—Diagram of some of the conduction paths in the forebrain of fishes and amphibians, based on the salamanders. For the external form of such a brain, see Fig. 8, p. 73, and Herrick (1924*c*, Figs. 1 and 2). Somatic sensory paths (optic, auditory, somesthetic) are drawn in heavy continuous lines; thalamic radiations to the cerebral hemisphere in heavy dot-and-dash lines; visceral sensory and gustatory paths in light dotted lines; hypothalamic radiations to the cerebral hemisphere in light dot-and-dash lines; olfactory paths in broken lines. The "striatum" includes the incompletely differentiated strio-amygdaloid complex.

the roof of the midbrain, (2) the thalamus, (3) the hypothalamus, (4) the endbrain (true cerebral hemispheres in forms above fishes). The midbrain contains very complex correlation mechanisms which are dominated physiologically by optic nervous impulses coming in directly from the retina.

The physiological characteristics of the thalamus of these lower vertebrates are in some respects very

similar to those of the midbrain roof; but there are significant differences. It receives some optic fibers directly from the retina, but these are relatively few in number. Most of its afferent fibers come from the midbrain roof and the sensory centers of the medulla oblongata and the spinal cord, regions in which the sensory impressions discharged directly from the periphery are locally subjected to a certain measure of correlative modification or reflex control through interconnecting fibers coming from other primary sensory centers. In other words, the afferent fibers reaching the thalamus (except the small optic tracts) do not transmit crude sensory data directly from peripheral sense organs but more or less fully elaborated reflex patterns in which several simultaneous or successive excitations of diverse sorts are represented. Like the midbrain roof, the thalamus is concerned chiefly with excitations coming from outside the body (exteroceptive in Sherrington's sense) and with the adjustments of the body to these external conditions. It also receives a generous contribution of fibers from the proprioceptive centers, especially those concerned with muscle sense and allied sensory systems of motor control.

The thalamus is a true correlation center in the sense that it is not dominated by any single system of sensory excitations. In none of these lower vertebrates is it very large or very complex in internal structure. In terms of the physiological conceptions



which we have already developed (p. 40ff.) most of the behavior of these animals is evidently controlled in the primary sensory centers (olfactory, optic, tactual, etc.), with the aid of their connecting fiber tracts and the proprioceptive adjustments of the cerebellum. But when problems of conduct arise for which this simply organized apparatus is inadequate the nervous excitations overflow into the thalamus, and here the reflex elements may be recombined in new patterns. The animal first tries out reflexly the simple reactions which come most naturally to it; failing to find a satisfactory mode of response in this way, the thalamus is activated, and there results some less usual but more effective type of response.

The hypothalamus repeats the general plan of the thalamus, with however a quite different functional complexion. Most of the afferent hypothalamic fibers come from olfactory centers in front and from centers of taste and general visceral sensibility of the medulla oblongata, and there is also an extensive system from the exteroceptive centers of the midbrain roof. In short, the hypothalamus is a true correlation center for olfactory, gustatory, visceral, and somatic adjustments, and in lower vertebrates this field is much more highly elaborated than is the thalamus.

The reason for the differentiation of separate centers of correlation in the thalamus and hypothalamus is now clear. The first is concerned primarily with adjustments of the body or its members to external con-

ditions, the second with visceral adjustments in response to changes in internal state as well as to environmental changes; and for these two kinds of adjustment the mechanisms of response are necessarily very different. The separation in space of thalamic and hypothalamic centers is more directly related to differences in their motor connections than to differences in their sensory connections.

The diencephalon is a relatively neutral zone between the large olfactory centers above and the centers of visual and other types of sensibility below. Here the descending correlation tracts from the olfactory field meet the ascending fibers of all other sensory systems. And the interaction of these great streams of nervous transmission appears to have been the most decisive factor in the fabrication of correlation centers of thalamic type. The thalamus continues, even up to the human brain, to be a very important adjuster of olfactory and visceral reactions. It also retains control of some of the exteroceptive functional adjustments of simple form, but the most significant of these for higher behavior are in later phylogenetic stages transferred to the cerebral hemispheres, whose organization will be considered more in detail in the next chapter.

In connection with the problems of the corpus striatum and cerebral cortex our interest here centers in the thalamus, whose ascending connections are with the lateral wall of the cerebral hemisphere and

the overlying cortex when this latter is present. Parallel with the four types of cortical differentiation (p. 70) we may outline four stages of thalamic evolution, as follows:

1. *The ichthyopsid stage.*—The thalami of fishes are simply organized, and in many cases they have differentiated in aberrant directions. In the lower Amphibia (as in *Necturus* and *Amblystoma*, Herrick, 1917, 1925*a*) the thalamus is seen in diagrammatic simplicity (Fig. 30). The bodies of the neurons are in the primitive position as central gray matter bordering the ventricle (shown as coarse stipple in the drawing). Within the dorsal part of the thalamus there are no differentiated cell clusters or “nuclei,” and the whole of this region may be termed “nucleus diffusus thalami” (the nucleus sensitivus of Cajal, or general sensory correlation center). The ventral thalamus (subthalamus) is chiefly efferent in function, discharging downward toward the motor centers. Most of the functions of this thalamus are local reflexes intrinsic to the thalamus itself, but there are small wisps of fibers passing from the dorsal part of the thalamus to the lateral wall of the cerebral hemisphere—the beginnings of the sensory radiations or projection fibers. The preoptic nucleus of Figure 30 is continuous behind with the hypothalamus and may be regarded physiologically as part of it.

2. *The sauropsid stage.*—In the frog the nucleus diffusus thalami has begun to break up into separate

nuclei, and in reptiles and birds these thalamic nuclei are well separated, each having its own characteristic type of functional connections. This thalamus evi-

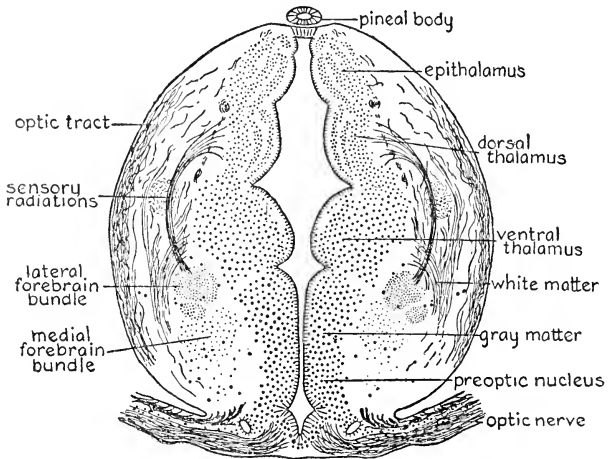

FIG. 30.—Diagram of the structure of the diencephalon of *Amblystoma* as seen in cross-section. The dorsal thalamus is a general sensory correlation center, from which sensory radiations descend to the lateral forebrain bundle within which they pass forward to the lateral wall of the cerebral hemisphere. There are connections (not drawn) from the dorsal thalamus to the ventral thalamus, from which fibers go to the lower motor centers. The medial forebrain bundle connects the preoptic nucleus and the hypothalamus, which lies immediately behind it, with the cerebral hemisphere.

dently performs very complex local or intrinsic reflex adjustments, and in addition the extensive sensory radiations maintain intimate functional connection between the thalamus and the lateral wall of the cerebral hemisphere. In birds (Ingvar, 1923) and in rep-

tiles (Huber and Crosby, 1926) these fibers connect for the most part the medioventral nuclei of the thalamus with the hypopallium; whether any of them reach the cerebral cortex directly is uncertain.

3. *The mammalian stage.*—In lower mammals the elaboration of thalamic nuclei is further advanced and extensive connections are made directly with the cerebral cortex, chiefly from the lateral nucleus and lateral and medial geniculate bodies (for somesthetic sensibility, vision and hearing, respectively). Cortical localization of “projection centers” associated with these three great systems of projection fibers is more or less clearly defined.

4. *The human stage.*—In man the thalamus is tremendously enlarged and complicated and the cortical connections are more extensive than in other mammals. The lateral nuclei and pulvinar are elaborated parallel with enlargement of association fields of the cortex and the greater differentiation of the supragranular layers of the cortex of Bolton (p. 91). Thus the thalamus, as well as the cortex, is seen to reflect in its structure the change in behavior patterns as we pass from brute to man.

In reviewing these stages, it is to be remembered that the thalamus is older than the cerebral cortex, though not older than the primordia out of which cortex has been differentiated. The simplest known type of thalamus is a very slightly modified sector of the primitive neural tube in which the bodies of the

nerve cells are crowded in a central gray layer next to the ventricle with dendrites and axons extending outward into a superficial white layer where the synaptic junctions are made. Into this nucleus diffusus thalami there enter a few optic fibers directly from the retina and a larger number of fibers from the mid-brain roof carrying somesthetic, optic, and perhaps auditory influences. The mesencephalic fibers come from the most elaborately developed correlation center of these primitive brains, and the nervous impulses which they transmit may be the resultants of the interaction of all forms of external stimulation to which the body is subjected (except the olfactory, and these may enter this field by another pathway).

In the Amphibia a few fibers enter the thalamus directly from the primary optic, tactile, and acoustic centers, but most of them come from the midbrain roof. In the lower species of this group all of these fibers converge upon the same neurons and there is no precise localization of thalamic centers for the various sensory functions represented in the incoming fibers. This can only mean that the thalamus here acts as a whole, equipotentially, in exerting some sort of an influence upon processes already going on in the lower centers from which it is activated and into which its own efferent fibers discharge.

Even in the salamanders, however, we can recognize the beginnings of the process of sorting out of the incoming fibers, with a tendency for those of certain

systems to concentrate in particular parts of the nucleus diffusus. There are no specific "nuclei," but certain parts of the thalamus receive more fibers from one source and other parts from different sources. In other words, one functional system may be prepotent in one place and a different system in another place. The influence which the thalamus may exert upon behavior at any particular moment will depend upon the balance or physiological equilibrium among all the incoming nervous excitations then prevailing in the thalamus as a whole.

In the frog the splitting up of the nucleus diffusus thalami into local "centers," each with characteristic and tolerably well-defined functional connections, is further advanced, and in all higher animals most of the neurons of the thalamus are arranged in definite "nuclei." The number and arrangement of these nuclei vary from species to species. In man more than two dozen such local centers can readily be distinguished microscopically in the thalamus.

The thalamic nuclei are interconnected by a complicated fabric of nerve fibers, some arranged in definite bundles or tracts and some diffusely spread. The entire thalamus, even in man, must therefore be thought of as activated locally more or less intensely in a variety of places under the influence of processes going on in other parts of the brain. These local excitations spread more or less widely, in part through definite pre-established fiber tracts and in part dif-

fusely. The outflow from the thalamus, downward into lower motor centers or upward into the cerebral hemispheres, will be determined as to its direction, intensity, and other physiological characteristics by the balance struck within the thalamus among the nervous energies there released.

This "equilibrium theory" of nervous action has not as precise experimental confirmation as we would like, but it seems to be consonant with the known facts and to provide a serviceable viewpoint from which to envisage the apparatus of compounding simple reflexes and the establishment of new patterns in associative memory and conditioned response.

In terms of more general physiological conceptions as Child (1924) and I (1924) have formulated them, we may say that cerebral regions at the moment under excitation are physiologically dominant over unexcited parts and that the efficiency of this dominance is dependent in part upon the intensity of the excitation and in part upon the conductivity of the intervening lines of transmission. Certain associational pathways are laid down at birth. Their conductivity is good. These provide the mechanism of the "natural" or innate action system. Other pathways of naturally higher resistance have their conductivity improved during postnatal experience by the method already suggested (p. 52) in our schematic analysis of the conditioned reflex. Through this secondary or conditioning process the "natural"



dominance and subordination of parts is altered, probably by an enduring change in the conductivity of certain associational connections, and to this extent new behavior patterns replace the innate action system. The animal has acquired a habit, or learned something.

We have here dwelt at length on the established facts of the evolution of thalamic structure and a theoretic formulation of the dynamics of thalamic function because some sort of a working schema of thalamic organization is an essential approach to the problems of the cerebral cortex. Moreover, the history of the differentiation of the cortex is in some respects very similar to that of the thalamus, and it seems highly probable that the fundamental dynamics are essentially the same, however differently they may work out in detail.

If we think of the brain as an office building containing several rooms, each of which is crowded with many desks where various sorts of business are transacted, the relations of the parts of which we have been speaking can be crudely drawn as a diagram of the ground plan of such a house. In Figure 31 I have attempted to express in a rude way the offices and corridors that must be traversed in the course of the ordinary routine of business in the forebrain of the cerebral types enumerated above. Only the relations between the thalamus and the lateral wall of the hemisphere of one side are considered. The olfactory

and hypothalamic connections are not included, and no attempt has been made to analyze the thalamo-

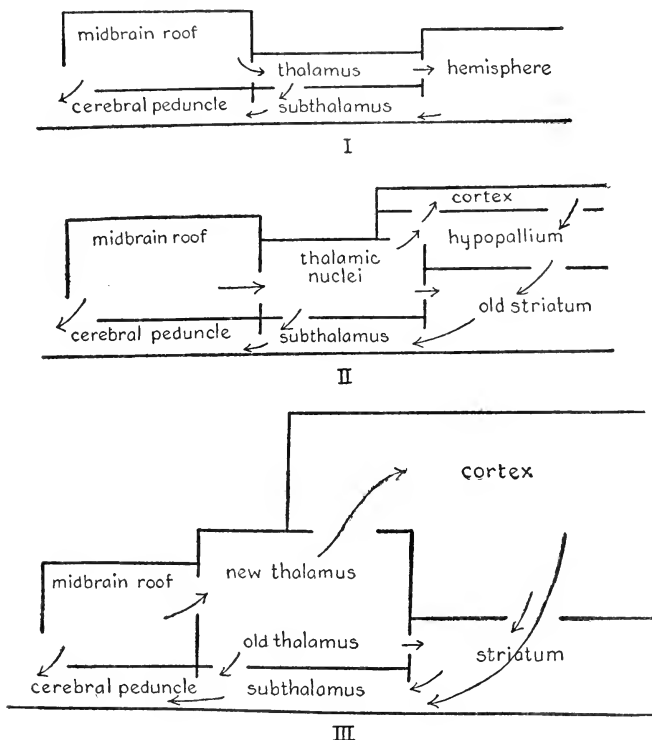

FIG. 31.—Diagram of the connections of the thalamus with the lateral wall of the cerebral hemisphere. I. Ichthyopsid type. II. Sauropsid type. III. Mammalian type.

cortical connections of mammals, though the facts necessary for such an analysis are available, as we shall see.

It is clear from the preceding discussion that the

thalamus (or better, the diencephalon as a whole) performs two very different kinds of function. First, there are the intrinsic thalamic reflexes and their mutual adjustment locally; and, second, there are thalamo-striatal and thalamo-cortical relations of diverse sorts. Normally in higher animals these two kinds of function are probably never performed independently of each other; and yet it is clear that these are independent variables, and when the matter is viewed comparatively the second kind of activity becomes progressively more important relatively to the first as the vertebrate series is ascended from fishes to men.

Nevertheless, the local or intrinsic thalamic functions are probably not less, but more, important in man than in lower forms. In certain diseased conditions where the thalamus is isolated from its cortical connections by destruction of the thalamic radiations the functions of the thalamus itself come into the foreground of the clinical picture. In this "thalamic syndrome" pure affective experience is intensified. The slightest stimulus may be extremely painful, but there is no intelligent analysis of the experience or localization of the stimulus. It is sheer pain, uninterpreted and better expressed by "it hurts" than by "I feel a pin prick in my hand."

That the thalamus, even in man, plays a large rôle in the fabrication of conscious experience is suggested by many clinical cases. Head (1920, vol. 2, p. 600) is of the opinion that here are localized, not only

the nervous processes concerned with the strictly affective components of experience, but also those of some of the simpler cognitive processes ("protopathic" sensibility, etc.). Winkler (1911) cites a case of a tumor of the thalamus which leads him to conclude that recognition of forms requires a thalamic synthesis of tactual and visual nervous impulses.

Before leaving the thalamus, further attention should be directed to its peculiar function as a center of integration for all those processes that co-operate in the fabrication and maintenance of those enduring attitudes and reaction types which give to the individual his own peculiar character and personality and perhaps his feeling of personal identity. These are doubtless partly innate and partly acquired patterns of synthesis of exteroceptive, proprioceptive, and visceral experience, superposed upon the lower reflex mechanisms but for the most part not intelligently fabricated. The organization of these "intimate senses" into the stable patterns which we call "personality" is at a very low level in forms below the mammals (so far as we know); but within the mammals there is progressive increase in the size and structural complexity of the betweenbrain and parallel with this an elaboration of its intrinsic functions in several directions. There is, first, a more closely knit assembling of all those internal processes, both inborn and acquired, which give the organism its sense of well being or malaise, its awareness of per-

sonal identity, and its distinctive disposition and character. Animals at least as low in the scale as dogs show very marked individual differences in these respects, as everyone who has kept dogs knows very well. There are also certain specific thalamic reflexes and the discharge of thalamic activities upward into the cerebral cortex. Finally, the thalamic functions are under cortical control through an extensive system of fibers from cortex to thalamus.

These are probably some of the characteristics of the thalamus in higher mammals, though of the details our exact knowledge is still meager. There are few changes of radical import between the brain of the frog and man in relative size of parts and arrangement of the connections shown in Figure 29 except in the thalamus, cerebral hemispheres, and parts dependent upon these. The apparatus of internal regulation is fairly well organized in the frog, and the thalamus clearly plays a large part in these functions; it is in the adjustments to outside events that we see the greatest advance. For success in getting on in the world depends largely on fitting our behavior into the rapidly moving sequence of happenings around us, whether in a frog or a man. The connection of the exteroceptive sense organs with the cerebral cortex and the development of the subcortical apparatus subsidiary to these connections mark the leading features of further advance in brain development between frog and man.

## CHAPTER VIII

### THE CEREBRAL HEMISPHERES

*It is the long serial reactions of the "distance receptors" that allow most scope for the selection of those brute organisms that are fittest for survival in respect to elements of mind. The "distance receptors" hence contribute most to the uprearing of the cerebrum.*

—C. S. SHERRINGTON

**I**N the walls of the forebrain of lower vertebrates it is possible to chart with tolerable precision the arrangements and boundaries of the various regions within which are the mechanisms by which most of the larger groups of reflex correlation are effected. Some of the necessary data have been established by direct physiological experiment. Others are deductions from the known anatomical connections of the parts. The second method is not so convincing as the first, and yet when properly controlled it is very dependable.

The functions of the peripheral end-organs and their nerves and of the primary cerebral sensory and motor centers of these nerves are easily accessible to direct experimental study, and they are well known. In so far as these centers are connected with one another and with other parts of the brain by anatomically well-defined fiber tracts, the functions of these tracts and of the higher centers of correlation into

which they may discharge can be inferred with reasonable assurance.

The neurologist's problem is somewhat like that of an electrician who is sent to a large factory building, of which he has no previous knowledge, with orders to prepare a complete wiring chart of the building. Beginning with the generators, he first determines the sources of the current and the various kinds of electric energy there supplied (direct, alternating, high and low voltage, etc.). The feed wires are then followed through their conduits, switchboards, transformers, etc., to their respective lamps, heating units, motors, and so on. In the end he has, not only a map of the courses of all of the circuits, but also information regarding the purpose to be served, the function of each of them.

So the neurologist builds up his wiring chart of the body and thereby secures tolerably reliable information about the functions of those deeper parts of the brain whose experimental study is very difficult. The inferences thus drawn have been adequately checked experimentally in a sufficiently large number of cases to demonstrate the validity of the anatomical method when skillfully executed.

The arrangement of the parts of the cerebral hemisphere in one of the lowest mammals is illustrated in figures 32 and 33, taken from Obenchain's excellent memoir (1925). In these very lowly South American marsupials the external aspect of the cerebral hemi-

sphere is very similar to that of the turtle, though internally the structures are not so much alike. Comparing Figure 32 with Figure 20 (p. 104), the pyriform lobe and amygdala are as large in the mammal as in the reptile. In *Orolestes* (as in some reptiles) the corpus striatum is entirely covered by pyriform cortex, and so is the greater part of the amygdala. On the medial surface the hippocampal cortex (Fig. 33, *hip. ant.*) is apparently smaller than in the reptiles; but this appearance is deceptive, for the greater part of the elaborate hippocampus is rolled inward and concealed from view. The pyriform cortex, too, is structurally much more complicated than in reptiles, as already illustrated (cf. Fig. 11 with Fig. 13, pp. 84, 85).

The hippocampus and pyriform cortex are dominated by the olfactory system. The non-olfactory, or somatic, cortex forms the dorsal convexity of the hemisphere, extending from the rhinal fissure laterally (Fig. 32, *fs. rh.*) to the hippocampal fissure medially (Fig. 33, *fs. hip.*). It is superficially scarcely more extensive than in some reptiles, but structurally it is much more complex (Fig. 14, p. 85).

The olfactory cortex apparently attains almost its maximum size and structural complexity in these very primitive mammals, but the somatic cortex is here smaller than in any other mammals with two or three exceptions. The somatic cortex from this meager beginning increases progressively in size and internal structural differentiation up to its culmination in



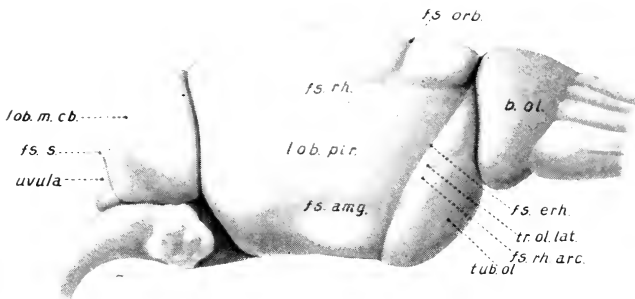

FIG. 32.—Lateral view of the brain of *Orolestes inca*, enlarged about four times. After Obenchain (1925). The olfactory bulb (*b. ol.*) is very large. The small cerebellum shows a large lobus medius (*lob. m. cb.*) bounded behind by the fissura secunda (*fs. s.*). The cerebral cortex shows two fissures. The orbital fissure (*fs. orb.*) cuts across the excitable motor field, and the rhinic fissure (*fs. rh.*) separates the neopallium above from the pyriform lobe (*lob. pir.*) below. The latter is separated from the amygdala by a shallow amygdaloid fissure (*fs. amg.*). The olfactory tubercle (*tub. ol.*) is a subcortical reflex center, separated from the cortex by the large lateral olfactory tract (*tr. ol. lat.*), which in turn is bounded above by the fissura endorhinalis (*fs. erh.*) and below by the fissura rhinalis arcuata (*fs. rh. arc.*).

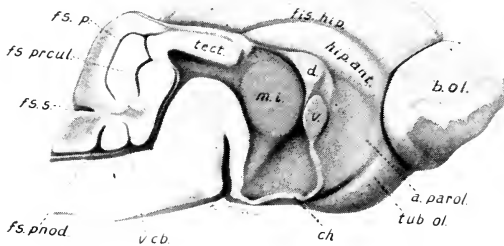

FIG. 33.—Median section of the brain of *Orolestes*. After Obenchain. The very small neopallial cortex extends over upon the medial aspect as far as the hippocampal fissure (*fis. hip.*), below which is hippocampal cortex (*hip. ant.*). Still farther ventrally are the septum, or parolfactory area (*a. parol.*), the olfactory tubercle (*tub. ol.*), dorsal or pallial commissure (*d.*), ventral or anterior commissure (*v.*), massa intermedia of the thalamus (*m. i.*), and farther back the tectum (*tect.*), or roof of the midbrain. The optic chiasma is at *ch.*



man, where further specialization is probably still going on. For this reason Elliot Smith many years ago proposed to call the somatic cortex neopallium. Kappers calls the pyriform cortex palaeopallium and the hippocampal cortex archipallium. In this work the entire olfactory cortex is called archipallium, for the hippocampal and pyriform cortex seem to be genetically and functionally related.

Obenchain (1925, p. 218) calls in question the current belief that the hippocampus reaches its "maximum development" in lower mammals. If we take into account, not mass but internal structural complexity of the hippocampus, it seems more probable that the differentiation of the neopallium and of the nobler cortical functions in higher mammals is correlated with elaboration rather than reduction of hippocampal structure and function in primates.

Of the subcortical parts, the septum (Fig. 33, *a. parol.*) is about as in reptiles. Ventrally of the septum there is an enormous olfactory tubercle (*tub. ol.*) which is intimately related with the head of the caudate nucleus and probably serves the muzzle reflexes of feeding reactions. The corpus striatum is as already described in chapter vi.

The arrangement of the thalamic nuclei which send projection fibers to the cortex in a primitive mammal is shown diagrammatically in Figure 34, and here it will be noticed, as Elliot Smith (1910) has pointed out, that the arrangement of the correspond-

ing cortical fields is apparently determined by that of the older thalamic centers. The tactile and auditory fibers go out laterally to their cortical projection centers. The visual fibers pass more dorsally. In higher mammals the visual cortical area has been

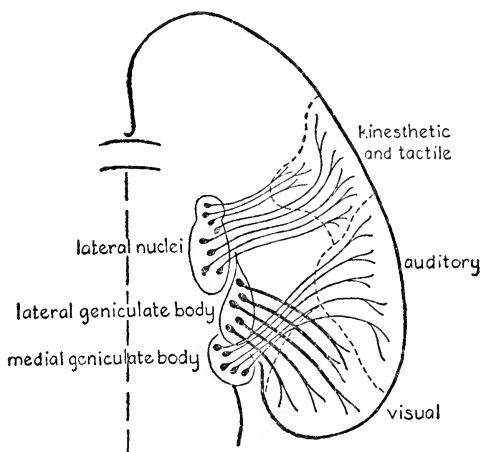

FIG. 34.—Diagram to illustrate the relations of the thalamic centers for touch, vision, and hearing to the cortical projection centers as seen in horizontal section of a primitive mammal.

carried farther backward by the enlargement of the posterior pole of the hemisphere. These projection centers comprise nearly all of the neopallium except the frontal pole. Accordingly, motor cortex (primitively kinesthetic-motor) is developed within the somesthetic field and in front of it.

The anatomical analysis of the cerebral cortex of

Orolestes has not been completed, but in a simple insectivorous animal, *Macroscelides*, as figured by Elliot Smith (1924), we see an arrangement which is probably equally primitive. This drawing is here reproduced as Figure 35.

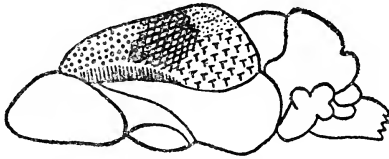

FIG. 35.—Brain of the jumping shrew, *Macroscelides*, illustrating the cortical areas. After Elliot Smith (1924). The neopallial areas above the rhinic fissure (cf. Fig. 32) are conventionally shaded. In front, the area of coarse dots is the motor cortex; the cross-hatched area is somesthetic; and these two fields probably overlap extensively. Behind and above, the visual cortex is marked with fine dots; below this is the temporal or auditory area. The insular cortex, marked with vertical lines above the rhinic fissure, is the least highly specialized neopallial area.

The cerebral cortex of the opossum has been minutely studied by Gray (1924), and the areas which can be distinguished by differences in cortical structure are shown in Figure 36. The cellular arrangements of two of these areas have already been illustrated (Figs. 13, 14, p. 85). The area striata (*a. str.*, no. 17 of Brodmann) is clearly visual cortex; the area temporalis (*a. temp.*, no. 22 of Brodmann) is probably auditory; the tactile and somesthetic field is probably in the postorbital (*a. porb.*) and parietal (*a. par.*) areas of Gray behind the orbital fissure (*fs. orb.*), but this has not been experimentally verified.

The electrically excitable cortex of the opossum has been mapped by a number of physiologists. Gray and Turner (1924) secured the results indicated on Figure 37. It will be noted that the excitable cortex does not coincide with any of the microscopically de-

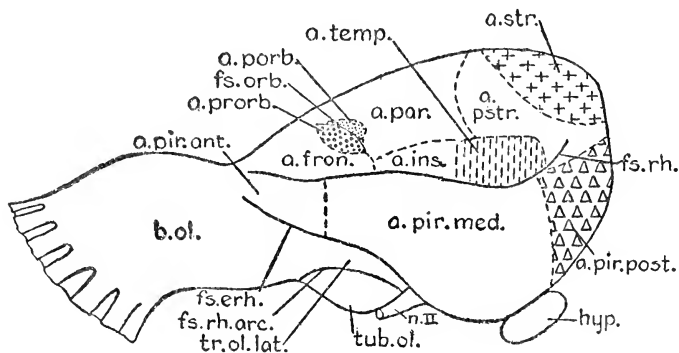

FIG. 36.—Topographic chart of the lateral aspect of the cerebral hemisphere of the opossum, showing the arrangement of the structurally distinct areas. Two and one-half times natural size. After Gray (1924). The rhinic fissure (*fs. rh.*) marks the boundary between the neopallium above and the pyriform cortex below.

termined areas. Nor is the excitable cortex of the skeletal musculature in the preorbital area (Fig. 36, *a. prorb.*) in front of the orbital fissure, an area which corresponds in position and structure with Brodmann's area gigantopyramidalis (precentral or Rolandic cortex of man). On the other hand, the arm area (points 1-4 of Fig. 37) lies in or near the postorbital area (Fig. 36, *a. porb.*), which in structure and

position corresponds with Brodmann's postcentral area, the somesthetic cortex of man.

These observations and others to be mentioned later suggest that in the marsupials the anatomical and physiological localization of cortical projection

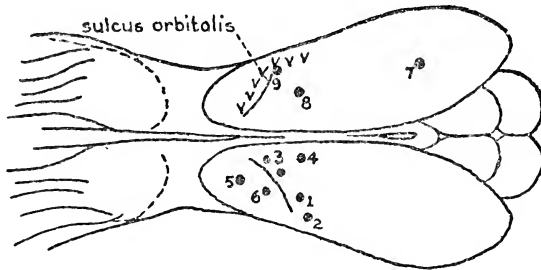

FIG. 37.—The electrically excitable cortical areas of the opossum as charted on the dorsal surface of the brain. After Gray and Turner (1924). 1, extension of the fingers; 2, flexion of the fingers; 3, flexion of the elbow; 4, twitching on the back of the forearm; 5, contraction of orbicularis muscle of the eye; 6, movements of the snout; 7, erection of the ear; 8, retraction of vibrissae; 9, movements of the tongue; v, erection of vibrissae.

centers as we see it in man and other higher mammals has not been completely attained.

Gray has demonstrated well-defined anatomical differences between the cortical areas of his chart (Fig. 36), and most of these areas resemble in structure and position particular areas of human and other brains sufficiently to justify their comparison. Yet this cortex is everywhere much simpler than the human, and the anatomical differences between the several areas are less clearly marked.

The physiological experiments suggest that these areas are fields of preferential function, but that these functions are not sharply localized in definite mosaic patterns. The dispersed arrangement of the electrically excitable points, the great variation found in successive experiments in the location of these points, and the nonconformity between the anatomically defined areas and the physiologically located points, suggest that the so-called motor cortex of the opossum is as yet very imperfectly organized. This is further supported by the very slight effect produced upon behavior by the extirpation of the entire excitable field (Gray and Turner, 1924; Rogers, 1924) and by the fact that the very small pyramidal tract extends only as far downward as the upper end of the spinal cord (Turner, 1924). These characteristics of the excitable cortex of marsupials indicate that cortical control of intentional movement is here in its incipience. Even in man, cortical control of ordinary routine behavior is probably far less precise than has been commonly supposed (Franz, 1921; Franz, Scheetz, and Wilson, 1915).

The brain of the rat, which will be the subject of several of the following chapters, has been much studied. The general microscopic structure of this brain is described and fully illustrated by Craigie (1925*a*). Most of the literature upon this subject is cited in the works of Donaldson (1924), Sugita (1917-1918), and Craigie (1925*a*). The cerebral cortex of the



rat has been investigated by both anatomical and physiological methods, and we shall next pass in review some of these facts.

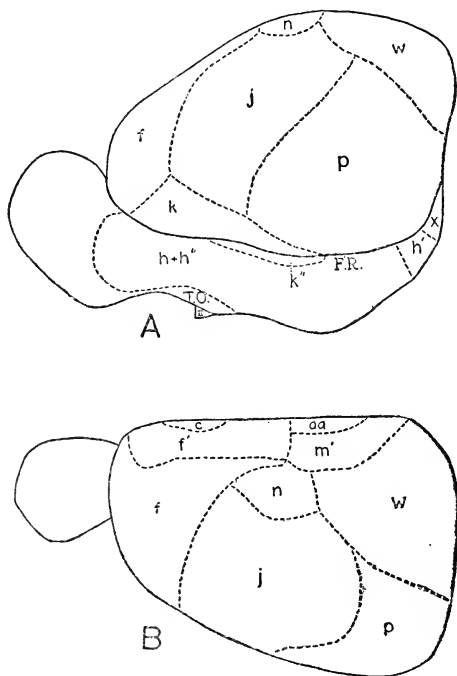

FIG. 38.—*A*, Lateral aspect of the cerebral hemisphere of the rat, showing the arrangement of the structurally distinct cortical areas. The rhinic fissure is marked *F.R.* *B*, Dorsal aspect of the same cerebral hemisphere. After Fortuyn (1914).

Figure 38 illustrates the general form of the cerebral hemisphere of the rat. As compared with the marsupials already figured the difference which is most significant for our purpose is the greater extent,

relatively and absolutely, of the neopallium and its more complex structure. The rat's cortex, however, is also of very primitive type; it is far less differentiated than that of the rabbit and some other rodents. Figure 39 is a diagram of the typical arrangement of the

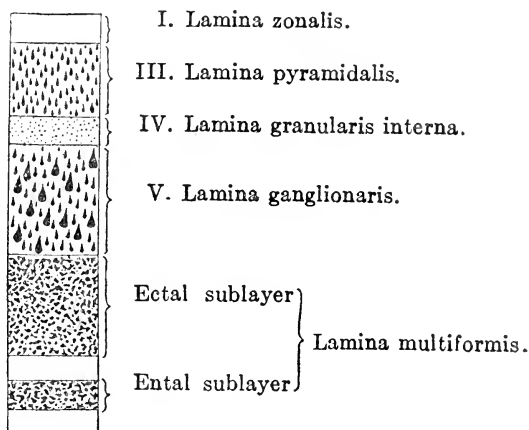

FIG. 39.—Diagram of the typical cell lamination of the cerebral cortex of the albino rat. After Sugita (1917).

cellular layers of this cortex. This arrangement differs in various parts of the cortex in the thickness of the layers and the sizes, shapes, and grouping of the nerve cells within them.

Microscopical examination of the cortex of the rat, mouse, and other small rodents has been made by a number of our most competent neurological workers. The greater part of Ramón y Cajal's monumental re-

searches into the minute structure of the brain were made upon the mouse. Brodmann has published an extensive series of anatomical studies (summarized in his book published in 1909) on the regional differences between various parts of the cortex in many animals, including the rabbit and several other small mammals. The cortical areas of the mouse have been similarly mapped by Isenschmid (1911), De Vries (1911), and others. The most ambitious and valuable research in this field is that of Fortuyn (1914), who describes in detail the cortical patterns of nine species of rodents, including the rabbit, mouse, and rat. A good summary of his conclusions is given by Sugita (1917-1918).

Figure 38 presents copies of Fortuyn's diagrams of the lateral and dorsal aspects of the rat's cerebrum, illustrating the arrangement of the structurally different cortical areas. The electrically stimulable cortical fields of the rat as charted by Lashley (1921) are shown in Figure 40.

Comparing the anatomical and physiological charts, the excitable cortex seems to be represented chiefly in Fortuyn's areas *f*, *f'*, *n*, and *m'*. The description of these areas tells us that they are all characterized by thin granular (IV) layers and unusually large pyramidal cells in layer V, these features being especially characteristic of the much more sharply defined excitable cortex of higher animals. But it should be emphasized that these features are only very

slightly accentuated in the brain of the rat, and nowhere is typical "motor" cortex as we see it in higher animals anatomically demonstrable. Area *n* ap-

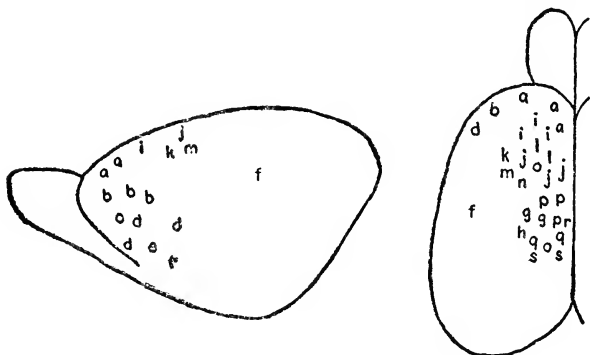

FIG. 40.—Lateral and dorsal views of the cerebral hemisphere of the rat, indicating the electrically stimutable cortical points. After Lashley. *a*, head turned to opposite side; *b*, nose retracted; *c*, vibrissae moved; *d*, chewing movements; *e*, tongue protruded; *f*, eye closed; *g*, ear adducted; *h*, ear erected; *i*, shoulder drawn forward; *j*, forearm retracted; *k*, elbow flexed; *l*, elbow extended; *m*, wrist flexed; *n*, forearm rotated; *o*, back flexed to opposite side; *p*, hind leg drawn forward; *q*, contralateral leg flexed, homolateral extended; *r*, ankle extended; *s*, tail drawn to opposite side. All movements are contralateral to the hemisphere stimulated except where indicated.

proaches this type more nearly than any other cortical field.<sup>1</sup>

The margins of area *j* are excitable, but this area as a whole seems to lie outside the excitable field. In

<sup>1</sup> Even in monkeys the motor cortex as determined physiologically is less clearly defined in anatomical structure than in man and at the margins there is gradual transition to the cortical patterns of adjoining fields (Nañagas, 1922).

structure, as in position, it seems to correspond fairly well with the somesthetic area (postcentral area, 1-3 of Brodmann) of higher brains. Both the anatomical and the physiological evidence suggest that somesthetic and motor projection areas of the rat overlap and are largely coextensive, and that neither of these cortical types has attained to more than incipient differentiation.

Area *p* occupies the position of the supposed auditory projection cortex of lower mammals (20-22 of Brodmann), and to this Fortuyn has devoted very especial attention. We have no direct proof that this cortex of the rat does serve the auditory functions, or that auditory projection fibers do enter it from the auditory area of the thalamus (medial geniculate body). The latter point, however, has been established for the rabbit by several workers, the most recent of whom is Yoshida (1924). In these experiments the supposed auditory cortex (area temporalis superior et medialis) was destroyed on one hemisphere and two weeks later the brain was prepared by Nissl's method. On the operated side the cells of the ventral part of the medial geniculate body were in pronounced chromatolytic degeneration, and the author concludes that fibers of the auditory sensory radiations arise from these degenerated cells for distribution in the temporal cortical field. Presumably the same anatomical connections are present in all rodents, and Fortuyn endeavored to confirm the audi-

tory function of this cortex in rodents by other evidence, with entirely negative results. Having made a minute examination of the cortex of area *p* in several kinds of rodents, he arranged these species in the order of their supposed acuteness of hearing, as follows: squirrel, guinea pig, rat, mouse, rabbit, waltzing mouse (totally deaf). Neither this nor any other order of arrangement of these species is found to correlate in any significant way with the relative size of area *p*, with the relative thickness of its supragranular cortex, with the number of spiral turns in the cochlea, or with the number of nerve fibers in the cochlear nerve. This does not prove, as Fortuyn points out, that area *p* is not auditory cortex, but it certainly leaves the question open for further study.

Area *w* of the rat is clearly comparable with the area striata, or visual cortex (17 of Brodmann) of other vertebrates. This is supported by its position, by its internal structure, and by physiological experiments to be cited later.

If now we compare the preceding data on the cerebral cortex of the rat with Gray's similar charts of the opossum (Figs. 36-37), the patterns are seen to be very unlike. Comparison of the detailed descriptions of the internal structure of the cortex of these two animals enables us to recognize some of the corresponding areas.

Area *w* of the rat is evidently directly comparable with the area striata of the opossum. In the rat the

distinguishing features of this cortex are much less well developed than in the opossum, and in the mouse they are scarcely at all evident. Isenschmid (1911, p. 40) calls attention to the fact that mice use their eyes less than rats, and from his account it seems probable that house mice, and especially albino mice, lack a specifically differentiated visual cortex altogether. Sugita (1917-1918) finds that the visual cortex is better developed (thicker) in wild Norway rats than in domesticated albinos, a feature correlated with the well-known poor vision of the albinos.

Waugh (1910) has made a critical experimental study of vision in mice. Their retinas lack cones. The experiments give evidence of poorly developed color discrimination (none in albinos). Discrimination of differences in brightness is fairly good, but discrimination of forms is poor. In the albino rat vision is at a primitive level. Color vision is absent (Watson and Watson, 1913), pattern vision is poor, perhaps absent, but the animal can distinguish differences in brightness and size and gross differences in the direction of single lines within the visual field (Lashley, 1912).

The supposed auditory area of the rat (Fig. 38, *p*) is comparable with the temporal area (Fig. 36, *a. temp.*) of the opossum and probably some adjoining parts. The excitable cortex of the opossum is less extensive than that of the rat (cf. Figs. 37 and 40); clearly in both cases no specific "motor area" com-

parable with that of primates is present, and probably motor and somesthetic cortical fields are at least in part coextensive.

The olfactory cortical fields of the archipallium of the opossum and the rodents are easily compared, and they are essentially similar except for the much larger pyriform lobe and underlying amygdala in marsupials. The remaining cortical areas are more variable from species to species than are the projection centers already considered, and it is not profitable in this connection to review them comparatively.

The cortical areas of the rabbit, mouse, and rat have been charted independently by several investigators.<sup>1</sup> When the reports of their examinations of the same species are compared the result is disquieting. All agree that in these lowly forms the boundaries between the various areas are indefinite and that the structural features by which the areas are distinguished are far less well defined than in higher brains. It follows that any chart of the anatomical localization within the cortex is necessarily more or less arbitrary, and the number of areas recognized, as well as their boundaries, will depend upon the criteria employed, the acuity of observation, the experience and discriminative skill, and other subjective factors of the several investigators. When it comes to comparison of one species with another, the pitfalls

<sup>1</sup> Brodmann (1909), Döllken (1907), Fortuyn (1914), Isenschmid (1911), De Vries (1911), Winkler and Potter (1911).



are still more numerous and treacherous, and the most critical students are very conservative about suggesting homologies.

When all of the available evidence is reviewed it is clear that in marsupials, rodents, and other lower mammals cortical differentiation is still in its incipency. There is great advance over the reptilian condition, where only three cortical areas are clearly evident and these are defined chiefly in terms of their subcortical connections, for the internal structure is very similar in all of them.

In lower mammals the archipallium has attained its definitive form, which is very complex; but the neopallium is very incompletely differentiated as compared with mammals of intermediate grade like the dog, and it is very rudimentary indeed as compared with the human. These facts must be kept in mind throughout the study of the part played by the cortex in behavior patterns in all of these animals.

## CHAPTER IX

### HOW DO RATS LEARN?

*The transition from learning to habit is a gradual one. Habit formation is complete when the act is performed with the minimum of afferent impulses, i.e., with the least attention. The nervous mechanism involved is essentially the same after the habit has become firmly established as on the first day the act was attempted, but the mechanism runs more smoothly. There is no basis for the belief that habit formation involves a lower order of nerve cells, or short cuts through the central nervous system.*

—F. H. PIKE

**I**N this chapter we shall consider the learning process of the rat in its relation to the cerebral cortex. Properly controlled experimental knowledge of the intrinsic functions of the cerebral cortex of animals below the mammals is so meager that for present purposes we may pass this question by and turn directly to a consideration of the functions of the cerebral cortex of the rat. Here we have a large body of experimental evidence derived chiefly from the researches of Lashley and Franz.<sup>1</sup> The problems suggested by these experiments will first be briefly stated.

It is generally believed that the cortex of man and other higher mammals is especially concerned with

<sup>1</sup> The titles of the more important works by these authors to which reference is here made will be found in the Bibliography.

the acquisition and utilization of individually learned experience as contrasted with those racial traits embraced under the terms "reflex" and "instinct." The rat's cortex has the same fundamental organization as the human, but simplified almost to the limit compatible with the recognition of this fundamental plan. The rat's behavior is similarly simplified. Now, learning is an aspect of behavior which readily yields itself to accurate investigation by quantitative objective methods, and the learning processes of normal rats have been intensively studied in this way. Accordingly, Lashley undertook a systematic exploration of the part played by the cortex of the rat in the acquisition of various habits. Some of the problems set were as follows.

1. Is the apparatus of learning restricted exclusively to the cerebral cortex? Obviously not, for worms and most other invertebrates can acquire "associative memories," that is, can learn, though they have no cerebral cortex whatever, and animals as high in the scale as dogs if deprived of the cortex still can acquire simple habits. Lashley's experiments on rats strongly confirm this conclusion.

2. Though the learning process is not restricted to the cortex, is there "any sort of nervous organization which is particularly well adapted for learning"; are there "any structures whose functional activity facilitates learning" (1920, p. 63)? This theme is discussed by Lashley very briefly and quite inadequately.

ly. He says, "The mere demonstration that animals with a complex cerebrum are capable of learning complex problems more rapidly than those at a lower evolutionary level will not answer the question." True; but if it is evident that the complexity of this tissue is commensurate with the complexity and rapidity of the learning processes and that this complex issue is essential for such processes, then we do have an answer. He says further: "The preexisting habits of the organism, the number and variety of instinctive responses available, the complexity of organization of existing reacting systems, perhaps the mere number of unemployed association fibers in the nervous system, all may influence the rate of learning, even though the underlying mechanism is the same." But by the very terms of this statement the underlying mechanism is not the same, and in so far as this greater complexity of organization is cortical and is essential for higher learning processes we may say that this cortex is "particularly well adapted for learning." And the evidence that in higher mammals the cerebral cortex does perform a necessary function in complex learning is unimpeachable. Even in rats Lashley's experiments show that a definite cortical field does in some way participate in the simplest possible brightness-discrimination habit, and his experiments certainly do not preclude an essential cortical rôle in various sorts of more complex habits; in fact, they strongly suggest such a participation. His

conclusion, "the phylogenetic evidence is not sufficient to prove that there has been any specialization of structure to facilitate learning," throws into the discard an enormous mass of evidence, difficult to evaluate, it is true, but in the aggregate very convincing, that the functional activity of the cerebral cortex does facilitate learning, at least of the more complex sorts, even though this holds no monopoly of the capacity for learning.

3. There is an opinion widely prevalent in psychological and pedagogical circles that habits acquired by cortical activity when thoroughly automatized are short-circuited at subcortical levels. Lashley finds very little actual evidence that this takes place. This opinion "seems to be based chiefly on the desire to hustle unconscious reactions out of the cerebrum and there is no conclusive evidence that any habit which may be performed at subcortical levels was not acquired there in the first place" (1920, p. 65).

His own experiments strengthen this conviction, for overtraining of rats by more than ten times the number of trials necessary to establish a habit produced no change in the relative parts played by cortex and thalamus in the reaction. A simple brightness-discrimination habit was used in these tests (1921). Normal rats acquire this habit in less than one hundred trials. It is totally lost after destruction of the visual cortex in the occipital poles of the hemispheres. After this operation it is reacquired in about the same

number of trials as in the first learning, and the rats which had been overtrained by more than twelve hundred trials did not reacquire the habit with more facility than did those which had received no overtraining. "There is no indication that subcortical nuclei have taken over any part of the reaction, even sufficient to facilitate relearning" (1921, p. 465).

4. Does cerebral injury give rise to disturbances in the general reactions of the rat such as would interfere seriously with learning, even though the essential structures for learning were still intact?

It is well known that complete or nearly complete decerebration in opossums (Rogers, 1924), dogs (Goltz, 1892; Rothmann, 1923; Dresel, 1924), and men (Edinger and Fisher, 1913), results in profound depression or stupor, alternating perhaps with decerebrate restlessness and loss of most of the complex habits. None of the rats studied were completely decerebrated, so that we do not know what the effect of this operation upon this animal really is. The partial operations may also have an effect on general vigor, motility, or specific sensori-motor reactions which affect the learning process, and this question was especially studied (1920, p. 68).

Normal animals and those with various partial destructions of the cerebral cortex were put into revolving cages so arranged as to record the revolutions on a kymograph. In this way the total activity of the different rats for twenty-four-hour periods could be

directly compared. Animals with total destruction of one cerebral hemisphere and those deprived of both occipital lobes were slightly less active than normal; and those with frontal injuries were more active than normal.

These differences in general activity must be taken into account in evaluating the learning processes of the operated rats, especially in the case of habits primarily involving kinesthetic activity. In fact, throughout the experiments it is clear that the partially decerebrated animals had a distinct advantage over the normals in learning these particular habits. In some cases this is clearly due to the fact that the less vigorous and frisky animals adjusted to the conditions of the experiment more readily than the more active ones; in other cases it is unexplained. The author found no evidence for any general disturbance of the reflex and instinctive reactions which might account for marked difference in learning ability (1920, p. 73). But it must be kept in mind that extensive injuries of the cortex, those involving more than 50 per cent of the cortical substance, and especially total destruction of the frontal cortex, do affect general motility and do impair (and in some cases abolish) the retention of kinesthetic-motor habits.

5. Is there any relation between actual amount of cortex functioning and the rate of learning, irrespective of possible localization of specific functions?

In various operations one entire hemisphere was removed and different parts of the cortex were removed from both hemispheres symmetrically. In different operations all parts of the cortex (except the olfactory fields, archipallium) were removed, and the effect on learning a kinesthetic habit (double-platform box, Fig. 47, p. 189) was observed (1920, p. 98). The conclusion is that "amounts of injury from 14 to 50 per cent of the entire cerebral cortex do not result in any correlation of the learning ability" (p. 100). "There is no evidence that the injuries to the cerebrum resulted in any reduction of the power to learn. . . . Whether greater injury than 50 per cent would cause deterioration has not been determined" (p. 101).

These conclusions apply, of course, only to the double-platform box experiment. They indicate that for this habit no specific localizable cortical field is necessary. This habit, like simple maze-running, does not seem to be at basis a cortical function at all (though normally the cortex may participate in some way not as yet determined). Lashley seems to be inclined to interpret the evidence as tending to show that the entire cortex is equipotential in learning. In reality these experiments shed no light upon the mechanism of cortical participation in this particular learning process, but rather suggest that if this process reaches the cortical level at all it is only in some way not brought out by the procedure adopted.



That the cortex, even in the rat, is not physiologically equipotential in learning is suggested by the local participation of the frontal pole in the inclined plane latch-box experiment to be described later, and this is clearly proved by the brightness-discrimination experiments of Lashley to be taken up shortly.

It should, however, be borne in mind that there is much evidence, of which the experiments of Lashley are the most significant, that in addition to such localizable functions as may be demonstrable, the cortex as a whole does exert a profound influence upon many (perhaps most) subcortical activities. These general functions may well be expressed in terms of the mass of the cortex involved without specific localization. It is suggested by the experiments that in the rat they are but little affected by the removal of less than 50 per cent of the cortex, but that they may be profoundly disturbed by more extensive injury.

The relation between cerebral mass, learning, and retention of the visual discrimination habit has been investigated by Lashley (1926) with especial care. He concludes that after acquisition of the habit subsequent injury to the visual areas of the cortex results in impairment of the habit which is closely proportional to the extent of the injury and independent of its locus within the occipital third of the cortex.

There are important efferent systems of fibers from the cortex to the corpus striatum, thalamus, cerebral peduncle, and cerebellum, in addition to

those of the so-called motor cortex in the pyramidal tract. The precise definition of the functions of these various efferent systems is one of the major unsolved problems of cerebral physiology.

6. In what sense is there localization of function in the cerebral cortex, and in particular, can specific projection centers and association centers be recognized in the rat?

Lashley's experiments were directed very explicitly to this general problem and to certain special aspects of it to be mentioned immediately. These experiments have brought to light some very surprising conditions which are quite at variance with traditional ideas of cortical localization.

7. Are cortical functions which are demonstrably related with the learning process localizable in particular areas, or is the cortex of the rat equipotential in learning in all of its parts?

Lashley is greatly impressed by the failure of his experiments to reveal evidence for any relationship to the learning process of specific projection centers for definite sensory or motor systems except the visual (and perhaps the olfactory, which was not investigated). And he finds no physiological evidence for specific association centers of any kind, except within the visual field of the occipital lobes. Even here it is not certain that the visual field functions in the reintegration of habits as such, that is, in true association. It may participate in the habit simply as a nec-

essary link in a chain of neurons which are functional in the habit without being actually essential in the formation of the habit.

The fact that a brightness-discrimination habit acquired by a normal animal is totally lost after destruction of the visual cortex and the further fact that this habit may be readily acquired by a rat whose visual cortex has previously been completely removed suggest that the mechanism for *acquisition* of this habit, that is, for making the conditioned reflex associations involved, lies in the thalamus, but the participation of the cortical visual area is a necessary factor in the successful *retention* and *performance* of the habit provided this cortex was present when the habit was originally acquired (cf. p. 199). And yet this habit can be acquired *de novo* in the complete absence of visual cortex.

This statement raises more questions than it answers, and the part actually played by the cortex in habit formation is not demonstrated. Evidently, from both the anatomical and the physiological evidence, there are in the cerebral cortex of the rat more or less well-defined specific projection areas possessing direct fibrous connections with their respective sub-cortical sensory and motor centers. But the physiological relations of these projection centers to one another and to supposed associational tissue of the cortex in habit formation are still obscure.

8. The frontal region of the cortex in particular is

of especial interest from the standpoint of localization of function. This cortex contains specific fields each of which more or less definitely and uniformly evokes movements of particular systems of muscles upon electric stimulation. The question arises whether this electrically excitable area and the fibers of the pyramidal tract which descend from it always act as the final common path for learned reactions or for any cortical participation in such reactions.

So far as the rat is concerned, Lashley's experiments answer this question definitely in the negative. The brightness-discrimination habit, which is definitely abolished by destruction of the occipital cortex, is wholly unaffected by destruction of the entire motor area provided the occipital cortex is left intact. The fibers descending from the cortex which are essential for the performance of this habit in rats deprived of the frontal lobes (and presumably in normal rats) evidently leave the cortex from the visual area or from cortical tissue immediately surrounding this area—not from the so-called motor area. We have independent anatomical evidence of such fibers, descending from the visual area to the thalamus.

In the case of habits of kinesthetic type, the simpler ones are, in the rat, entirely unaffected by destruction of the entire frontal third of the cortex (or of any other third of it). More complicated habits of this type show some impairment or in some cases total loss after destruction of the entire frontal cortex,

and in higher mammals the disturbance of motor function becomes progressively greater as the zoölogical scale is ascended. Even in man, however, where loss of the "motor cortex" nearly or quite abolishes voluntary control of the affected muscles, some such control may be subsequently regained. The significance of this so-called motor cortex is, accordingly, one of the most puzzling problems in neurology.

9. What is the relation of the cortex, and particularly of the frontal cortex, to the corpus striatum in habit formation? This general theme has already been discussed, and it seems clear that in the course of vertebrate evolution there have been remarkable changes in the relations between cortex and striatum.

In Lashley's experiments on rats there was no evidence that the corpus striatum has any significant relation to the learning process except as unsymmetrical lesions of the striatum produced motor disturbances which affected the course of the reactions.

10. Finally, there is evidence in higher mammals that the frontal lobes have unique significance in the learning process (Franz, 1907; Lashley and Franz, 1917; Bianchi, 1922).

The later members of this series of questions (6-10) will be examined further in the following chapters.

## CHAPTER X

### MECHANISMS OF LEARNING IN THE RAT

*The physiological gradient is a case of protoplasmic memory since it represents the persistence of the effects of environmental action. The establishment of a gradient in a protoplasm may be regarded as a process of learning. In some protoplasms the memory persists only for a short time and gradients are only temporary. In other cases, once the gradient is established, the protoplasm never forgets, unless subjected to some environmental action powerful enough to obliterate the former memory. . . . The establishment of a persistent gradient is, in fact, the first step in the education of a protoplasm and the foundation of later behavior to the end of individual life.*

—C. M. CHILD

THE significance in normal behavior of the spasmodic movements resulting from electric stimulation of the “motor cortex” is still obscure. To this we shall return. The clearest evidence of definite localization within the rat’s cortex of a particular physiological function is presented by Lashley’s brightness-discrimination tests (1920, pp. 94, 103; 1921, 1921a, 1922, 1926). The habit was the simplest possible. The rats were given a choice of two alleys through which to reach food. One was illuminated, one was dark, and food was always given by way of the light alley, never through the dark one. Normal rats learn perfectly to take the lighted way in about one hundred trials.

The experiments clearly reveal a very peculiar relation of the cerebral cortex to this habit. After destruction of the visual areas of both cerebral hemispheres, rats can learn this habit as readily as do normal animals; but if rats which had acquired the habit with the cerebral cortex uninjured were then deprived of the posterior thirds of both hemispheres, then the



FIG. 41.—The total extent of all of the lesions in rats that lost the habit of visual discrimination after operation (stipple). The solid black area was common to all. After Lashley.

habit was totally lost. Upon resumption of training after the operation the habit was reacquired in about the same number of trials as were requisite in the initial training. Figure 41 illustrates in stipple the total area involved in all of these operations and in solid black the area common to all of them. The latter field coincides approximately with the visual projection area as defined anatomically (area *w* of Fig. 38, p. 158). Clearly this area is related with the performance of the habit, but it is not necessary for its acquisition.

More than a hundred and fifty animals were trained in this habit, and the effects of various opera-

tions upon the visual cortex before and after training were carefully studied statistically with adequate experimental and anatomical controls.

In the case of some kinesthetic-motor habits it has been shown that the habit is preserved (perhaps in an impaired form) if even a small part of the frontal cortex is left intact, though it is totally lost if the entire frontal cortex is destroyed (see p. 186). The relation of the visual habit to the occipital cortex is similar. Lashley says:

There is indication that, e.g., any extensive but incomplete destruction of the visual areas of both hemispheres in the rat is followed by inaccuracy of brightness discrimination, with great variability from day to day, such as has been reported by Franz in 1916 for aphasia, yet without any complete loss of any phase of the visual function.

In the final report on these experiments (1926) the results are summarized as follows:

Injuries to the occipital region inflicted before training and including every possible part of the occipital third of the cerebrum have no effect upon the ability of the animals to form the habit of brightness discrimination. Total destruction of the "visual" area does not reduce the speed with which a simple visual habit may be formed.

Injuries in the same region produced after the habit was established resulted in a weakening or total loss of the habit. The loss, as measured by the amount of practice necessary to re-establish the habit, was closely proportional to the extent of the injury and independent of its locus within the occipital third of the cortex.

Evidence is given to show that the loss of the habit is not the



result of operative shock, or of the production of scotoma. The degree of retention is a direct function of the amount of nervous tissue intact.

Lesions in the optic radiations and optic nuclei of the thalamus seem to retard learning of visual habits.

The relation between cerebral mass and the efficiency of retention is interpreted as indicating a summation of the activities of different parts of the visual area. This summation takes place in spite of the cutting of any particular group of associational fibers.



FIG. 42.—The total extent of the lesions in animals which formed the habit of visual discrimination after operation. The stippled area represents an animal in which training was not completed. After Lashley.

It is clear that visual habits are related with the occipital cortex in a much more specific way than are other habits.

The destruction of the occipital pole did not result in a loss of all habits, but only the loss of the visual one. . . . The tactile and kinesthetic motor habits were retained, only the visual habit was lost [1920, p. 113].

In another series of experiments, portions of the cortex other than the posterior third (and the olfactory cortex which was not significantly involved in any of the cases) were removed and the effects upon the brightness-discrimination habit noted. Removal of

the frontal third of the hemisphere does not interfere with the acquisition of the habit (1920, p. 94; see Fig. 42). It is evident that the "motor cortex" and pyramidal tracts are not essential for the acquisition of this habit.

Other rats were first trained in the brightness-discrimination habit and then various parts of the frontal

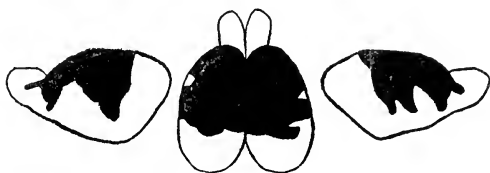

FIG. 43.—The total extent of lesions in animals which retained the habit of visual discrimination after operation. Not all of the darkened field was destroyed in any one rat. After Lashley.

and parietal cortex were removed. The total extent of all of these injuries is shown in Figure 43, but not all of the darkened field was destroyed in any one rat. After the operation some of these animals showed impairment of the habit but none of them showed total loss. They all gave unmistakable evidence of some retention of the habit. It may be concluded that no specific region of the cortex other than the occipital pole is essential for the preservation of this habit. In a later communication (1922) report is made of a series of experiments directed especially to this problem. The question is this: Is there some specific cortical area outside of the occipital pole which functions vicarious-

ly in visual habits when these are reacquired after destruction of the visual cortex?

The normal visual area was destroyed in twelve rats which were then taught the brightness-discrimi-

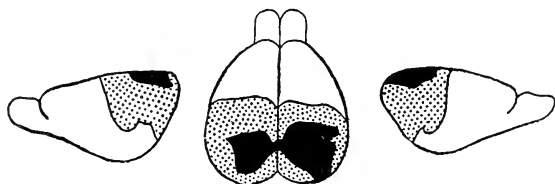

FIG. 44.—Composite diagram of the lesions in the first operation of twelve rats which acquired the visual habit subsequent to this operation. The solid black area was destroyed in all. The stippled area was destroyed in one or more. After Lashley.



FIG. 45.—Composite diagram of second operations performed upon the same rats illustrated in Fig. 44. The visual habit acquired after the first operation was retained after the second operation. After Lashley.

nation habit. The total extent of the lesions is shown in Figure 44. After the acquisition of the habit a second operation destroyed various parts of the remaining cortex. Each operation in general destroyed about a third of the remaining cortex, and in the aggregate they covered practically all of the neopallium (Fig. 45). These animals all retained the habit after the second operation.

These experiments seem to show that no other specific region of the cortex takes up the visual function vicariously after loss of the visual area. Complete decortication has not been successfully done in the rat, so that we do not know whether such an animal can reacquire the brightness-discrimination habit. Judging by what is known of the results of decortication in other species, this would probably be difficult but perhaps not impossible. Lashley says, "data now being accumulated indicate that the destruction of large cerebral areas (more than 60 per cent of the cortex) greatly retards or abolishes the power to form visual habits" (1922, p. 64). And other inconclusive experiments lead him to think "that complete destruction of the cortex abolishes a vicarious function which may survive lesser injuries, and that the cortex is the essential structure in this vicarious function."

If in these cases the surviving portion of the cortex (any surviving part, not some specific area) plays some rôle in the retention of the reacquired habit, it would seem that the process of relearning and retention is not wholly a subcortical matter. But there is no evidence of localization of this aspect of cortical function, and the exact function served by this surviving cortex has not been determined. This is a very interesting question to which we must return after examining the additional data on cortical participation in learning.

Turning now from these brightness-discrimination

experiments and recurring to the inclined plane latch-box experiments as described by Lashley and Franz in 1917, these contribute some further evidence bearing upon the problem of cortical localization of the learning process.

These experiments are limited (p. 75) to a "determination of the relation of the frontal pole and dorsal convexity of the cerebrum to the formation and retention of habits which involve chiefly responses to tactile and kinesthetic stimulation." The frontal pole or the entire dorsal convexity of the hemisphere was destroyed and the rats were then trained in a simple maze or a latch-box and their rate and manner of learning compared with normal. Conversely, normal animals were trained and after destruction of various parts of the cortex they were tested to determine the degree of retention or loss and in the latter case their ability to reform the habits.

The experiments described give no evidence of cortical participation at all in the formation and retention of a simple maze habit. This habit

may be retained after the destruction of any part or all of the cortex lying in front of and above the knee of the corpus callosum and after the destruction of any part of the temporal and parietal regions. The maze habit may be acquired after the destruction of all the cortex included within these areas, and after the destruction of one, perhaps both, of the striate nuclei [p. 133].

The case of the inclined plane latch-box habit is quite different. The rats were taught to climb upon

the top of a food-box (Fig. 46) and here depress a lever (*B* of the figure) which opens the door of the food-box. After destruction of the frontal part of the cortex, including the electrically excitable field, the rats learned

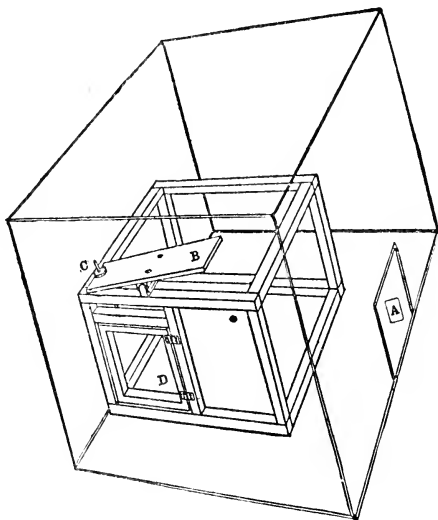

FIG. 46.—The inclined plane box. *A*, door of restraining cage; *B*, inclined plane; *C*, catch extending down to upper edge of door; *D*, door leading into food-box. After Lashley.

this habit as readily as do normal rats and they showed no obvious sensori-motor defects.

If previously trained and then operated upon, the temporal regions of the cortex can be removed without loss of the habit, but if the whole of the frontal regions is destroyed this habit is lost. Partial destruction of the frontal regions does not totally abolish the habit, but no particular part is necessary. "In the

more complex habit of the inclined plane box the presence of some portion of the frontal pole is evidently a condition for the performance of the habit where this has been acquired with the frontal pole intact" (p. 131).

If the frontal poles were almost completely destroyed the habit was impaired but not totally lost. In some cases of total loss of the habit it was reacquired more or less perfectly after additional training; in other cases it was not relearned, these probably in all instances having injuries to the corpus striatum in addition to the cortex.

In these experiments, as in those on the brightness-discrimination habit, we have clear evidence of cortical participation in the *retention* of the habit acquired by a normal animal. In the one case, the occipital cortex is necessary; in the other case, the frontal pole. In both cases, only a small part of the specific cortex is necessary and that need not always be the same part. In both cases, the habit may be *learned* by an animal from which any third of the cortex has been removed as readily as by normal rats. No particular part of the cortex is essential for learning, though the preservation of some cortex in a special region may be necessary for the preservation of a habit previously learned while the cortex was intact. Before further consideration of the significance of this very interesting situation, attention should be called to some further experiments upon problem-box learning.

We have now reviewed the positive evidence for cortical localization in the rat. On the negative side of the question there are some experiments which tend to obscure the significance of this evidence and even to suggest that the rat's cortex, in some of its functional aspects at least, acts in a non-specific way with no demonstrable localization. This evidence must next be examined.

In the first place, it has already been mentioned that in the case of simple maze-learning there is no evidence for any cortical localization of either acquisition or retention of this habit or indeed for cortical participation of any sort. The habit is learned in the absence of any third of the cortex with normal ease, and it is retained after destruction of any third of the cortex. What effect upon this habit is produced by total destruction of the cortex has not been determined. This case is very different from that of the brightness-discrimination habit which has a specific relation of some sort with the visual area in the occipital region and the inclined plane latch-box which is related with the frontal region.

In another series of experiments (1920) on kinesthetic-motor habits a different apparatus was employed—a double-platform latch-box (Fig. 47). The rat must first depress the platform *a* and then the platform *b* before the door of the food-box is opened. This is a more complicated reaction than that required to open the inclined plane box used in the earli-



er experiments as already explained (p. 186), but the separate movements were simpler and the rat does not need to climb upon the top of the food-box as before. The latch is tripped whenever in the course of or-

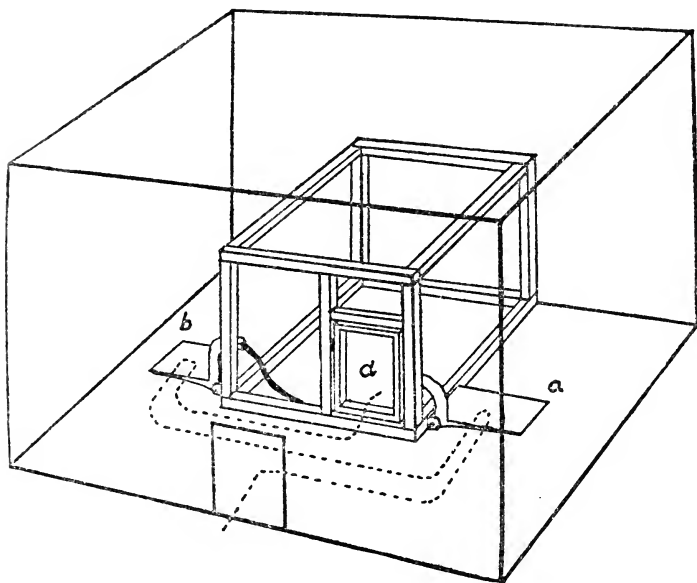

FIG. 47.—The double-platform box. *a* and *b* are platforms which must be pushed down in the order *a-b* so as to open the door, *d*, to the food-box. After Lashley.

dinary running movements the rat steps on both of the platforms in proper sequence. The normal rats readily acquired this habit perfectly, though this required about twice as many trials as did the mastery of the inclined plane box.

In these experiments a definite part of the cortex

was destroyed (usually by bilaterally symmetrical lesions), varying the operations so as to cover all regions of the cortex in the total series of experiments. The operated rats were then trained on the double-platform box and their methods of learning compared with those of normal animals. Figure 48 illustrates the total field covered by these different operations in the aggregate, showing that in one experiment or an-



FIG. 48.—The total extent of bilateral cortical injury in all of the rats subsequently trained on the double-platform box. After Lashley.

other the entire dorsal surface was explored and most of the lateral surfaces. The archipallium (as in other experiments) was not involved.

These rats learned the habit as readily as normal animals, indeed more quickly, in some cases in less than half the normal number of trials. Some of these cases parallel very closely the experiments of Lashley and Franz (1917) on the inclined plane box and show that both of these problem-box habits can be learned readily in the absence of the entire "motor cortex," or of any other third of the cortex (except archipallium, not tested). No details are given of the converse experiment. It has been shown that a brightness-discrimination habit can be learned after destruction of

any third of the cortex, but if learned with cortex intact it cannot be retained after total destruction of the occipital cortex. It was also shown that the inclined plane box habit acquired by a normal animal is impaired if part of the frontal cortex is destroyed and is lost entirely after total destruction of the frontal cortex.

In Lashley's first paper (1920) no experiments were reported which determined whether the more complex double-platform box habit acquired by a normal rat is retained after destruction of the frontal cortex. Later (1921*a*, p. 277) he writes, "There is some evidence, to be reported later, that the habit of the 'double platform box' is disturbed but not completely abolished by destruction of either the frontal or the occipital regions." It is probable, therefore, that this habit, like the inclined plane box habit, involves some participation of the frontal cortex in normal learning and retention and, unlike the simpler problem-box and maze habits, a co-operation of frontal and occipital cortex is also a factor in this normal learning process.

#### SUMMARY

From the foregoing survey of the anatomical and physiological evidence it is clear that the cerebral cortex of the rat is structurally diverse in its different parts and that this diversity of internal organization is correlated, at least in part, with differences in the subcortical connections of the different fields. These

subcortical connections define the limits of the projection areas of the cortex, although these areas are not so sharply delimited as in higher mammals. The rat possesses very little cortex outside of these ill-defined projection areas.

Physiologically, some of the cortical fields exhibit striking differences. An ill-defined fronto-parietal area is electrically excitable, but this "motor" cortex and the related pyramidal tracts do not seem to be essential for the learning and performance of many rather complex acts. It is probable that tactual and kinesthetic senses have cortical representation in a general region which is partly but not wholly coextensive with the electrically excitable field, but of the details our knowledge is incomplete. Certain visual functions are much more clearly related with a definite field in the occipital poles. No auditory area has been physiologically demonstrated (Lashley, 1921a, p. 276), though comparative evidence suggests that this sense is represented on the lateral aspect of the hemisphere. The olfactory sense is anatomically intimately connected with the archipallium, its connection with the pyriform lobe being much closer than that of any other lower sensory system with the cortex. We have as yet little physiological evidence of the nature of the cortical representation of the sense of smell.

The significance in behavior of the localization pattern of the rat's cerebral cortex is further discussed in the next following chapters.

## CHAPTER XI

### LOCALIZATION OF THE LEARNING PROCESS IN THE CEREBRAL CORTEX OF THE RAT

*The ability to learn by experience necessarily implies the development, somewhere in the brain, of a something which can act not only as a receptive organ for impressions of the senses and a means for securing that their influence will find expression in modifying behavior, but also serve in a sense as a recording apparatus for storing such impressions, so that they may be revived in memory at some future time in association with other impressions received simultaneously, the state of consciousness they evoked, and the response they called forth.*

—G. ELLIOT SMITH

THE problem of cerebral function was approached by Franz and Lashley with a definite system of preconceptions based on their former experience with the plasticity and inconstancy of cortical activity in contrast with the rigid mosaic schemes of cortical localization of function hitherto so popular. I have approached the problem with a different set of preconceptions based on very dissimilar experience. It would therefore not be surprising if we were inclined to evaluate the factual evidence somewhat differently, as indeed is actually the case. Our specific conclusions will, however, be found to be not far apart.

In the first report of this series of researches Lashley and Franz (1917, p. 133) wrote:

The ability of the animals to form habits after the loss of those parts of the brain which are normally used in learning, the reestablishment of motor control after the loss of the stimuable area of the cortex and of the corpus striatum, and the seeming equipotentiality of the different parts of the frontal pole in the functioning of complex habits go far toward establishing the complete functional interchangeability of all parts of the cerebral cortex.

This motif reappears in all of the subsequent reports, but to me it seems that this work in its entirety by no means points in that direction, even in the case of so simple a brain as that of the rat. The experiments do show less sharply defined mosaic localization of function than has often hitherto been supposed. But this is very far from "complete functional interchangeability of all parts," which is *a priori* improbable and is distinctly negated by the experiments reported. That there is a functional specificity of some sort corresponding to the known anatomical specificity of the cortex of the rat there can be no reasonable doubt. The problem is to devise experiments which are adequate to bring this specificity to light and reveal its character. The experiments already reported have gone a long way in that direction, especially in excluding certain types of mosaic localization formerly widely accepted.

In discussing the double-platform box habit, Lashley (1920, p. 101) concludes, "No single part of the

cerebrum has proved to be necessary for the learning of the double platform box and no single part has proved to be significantly more efficient in learning than any other part. For the acquirement of this habit the various parts of the cerebrum seem to be absolutely equipotential." And again he asks (p. 103), "What becomes of the concept of sensory and motor projection areas if the entire cerebral cortex of the rat is equipotential in learning?"

This raises the question, whether in the rat the cortex participates at all in the acquisition of simple trial-and-error habits of the sort here under consideration, and, if so, in what manner. Throughout the experimental series there is marked contrast between the *learning* process and the *retention* of normally formed habits.

The establishment of these habits of conditioned response type is an aspect of organic memory (with no necessary implication of psychological memory). In any mnemonic process we must distinguish three aspects: learning, retention, and recall. When a differentiated nervous system is involved the initial learning process presumably effects some enduring change in the internal organization of the correlation centers such as to facilitate a type of response different from that previously called forth by the stimulating situation. In the latch-box experiment we may schematize this process somewhat as follows.

In the untrained animal the presentation of food

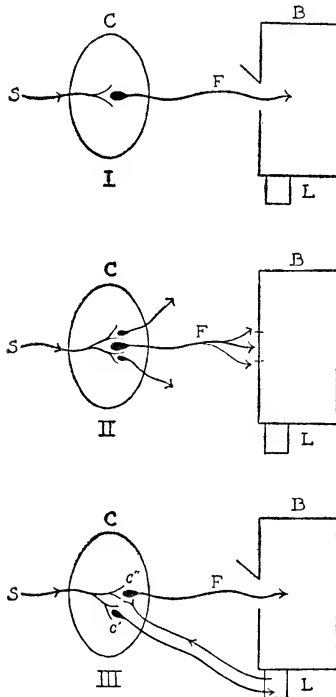

FIG. 49.—Simplified schemata of the situation at three successive stages of the latch-box experiment.

I. Before training. The “natural” reflex, upon presentation of the food stimulus ( $S$ ), involves transmission of a nervous impulse to the correlation center ( $C$ ), as a result of which the rat makes the reaction ( $F$ ) which takes it directly to the food in the open box ( $B$ ).

II. During early training. The “natural” response to the food ( $F$ ) is blocked by closure of the door of the food-box ( $B$ ). Summation and overflow of excitations in the correlation center ( $C$ ) result in various exploratory and random movements.

III. Completed training. The initial response is transferred from the food ( $F$ ) to the latch ( $L$ ), as indicated by the line  $C'-L$ . When contact with the latch is reported back to the center, as indicated by the line  $L-C''$ , this second stimulus evokes the original response, as indicated by the line  $C''-F$ , and the reaction is consummated.



in the open box (Fig. 49, I) activates the innate neuromuscular mechanism and the rat goes directly to the food. At the beginning of training the door of the food-box is closed (Fig. 49, II) and the natural reaction is blocked. There immediately follows direct attack upon the food-box, with perhaps some clawing and gnawing, followed by random exploratory movements. In the course of these movements the latch is accidentally tripped, the door flies open, and the way to the food is unimpeded. The consummatory reaction promptly follows through the same final common path as originally employed. After, say, a hundred such experiences the habit is fixed and the rat goes directly to the latch and after sensing this contact he goes directly to the food (Fig. 49, III).

This is the overt behavior. We do not know exactly what takes place in the central nervous system during this process. The evidence seems to indicate that upon blocking of the natural response there is summation of excitations in the center with more or less diffuse spreading of the excitation through such nervous pathways as may be available (p. 135). The resulting movements may be direct but futile attack upon the object or random activity. Some particular sequence of these movements results in satisfaction. After this result has been achieved a sufficient number of times, the familiar physiological principle of facilitation of path by use is manifested, and, as Sherrington expresses it, the appropriate pathway is smoothed by sheer

process of heavy traffic. The lines of central transmission have been transferred from the direct path between sensory receptor and final common path ( $S-F$  of the figure) to a roundabout way ( $S-C'-L-C''-F$ ). The details are unknown, but that something of this sort takes place is highly probable. In this process of facilitation there may be, and doubtless are, other changes involved, some central and some peripheral; but for our present purpose this central readjustment may be taken as representative of them all.

This is the learning process. It is an active change in the internal organization or "set" of the neuromuscular apparatus. Now, the retention is nothing other than the preservation, for longer or shorter time, of this change in the "set" of the apparatus. As long as this endures the "memory" is retained. No active process, either psychological or physiological, is involved. There is nothing about it more magical or esoteric than there is in winding an alarm clock at night in the assurance that when the hour-hand reaches six o'clock the spring will be released and the alarm which has been "set" will react in the way proper for all well-regulated alarm clocks. The recall is simply the reactivation by an appropriate stimulus of a mechanism which has through experience been so "set" that it will react in some learned behavior pattern when the appropriate trigger is pulled.

As we have seen, this is not essentially a cortical type of process, for it is perfectly exhibited by many

animals which normally lack cerebral cortex entirely. On the other hand, cortical participation is not excluded when cortex is available. In what fashion the cortex participates, if at all, is of course the problem before us. So far as published observations go there is nothing to indicate that in rats the cortex participates in any way in learning, retention, or recall of the simple maze habit. But we do not know whether the completely decorticated rat with no injury to subcortical structures can master or retain this habit.

The part played by the cortex in habit formation in rats is best revealed by the brightness-discrimination experiments to which reference has already been made (p. 178). In order to clarify the discussion I have ventured a hypothetical schematization of this process as illustrated in Figure 50. The first diagram (I) illustrates the case of the untrained animal. The first presentation of the maze to a hungry rat acts as a stimulus ( $S$ ) whose "natural" result is exploration of the maze, either in random search for food or perhaps because in previous experience the maze has been associated with feeding. The two alleys  $F$  and  $F'$  are alike. During the course of training (diagram II) food is always presented in an illuminated alley,  $F$ , never in a dark alley,  $O$ , so that the simultaneous presence of two stimuli, the maze,  $S$ , and the light in one alley,  $S'$ , is associated with the lighted alley. The neurologic connections involved in the thalamus are indicated at  $C$ .

We know that visual discriminations of similar sort can be acquired independently of the cerebral cortex, for they are successfully done by invertebrates and fishes (see, for example, Washburn and Bentley,

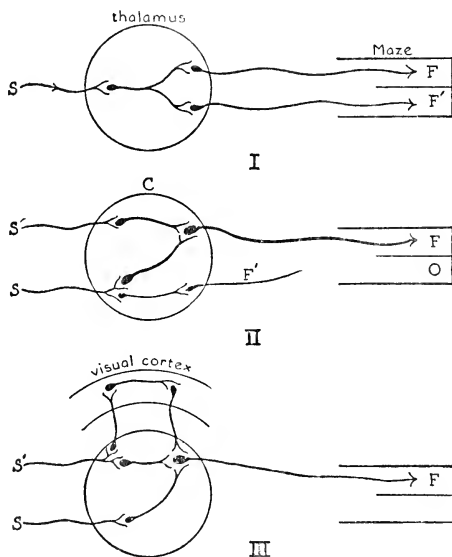

FIG. 50.—Schemata of the brightness-discrimination experiments. I. Before training. II. Thalamic connections established during training. III. Cortical connections established during training.

1906, and White, 1919). In the rat it is probably fundamentally thalamic, though we do not know whether it can be acquired in the absence of all of the cortex. It has been shown experimentally that such discriminations can be learned by rats in the absence of any particular part of the cortex except the archipallium,

and there is no reason to assume that the latter field is related with these habits differently from the rest of the cortex.

We are now confronted with the very remarkable fact that if a rat with cortex intact is taught a visual discrimination habit and then the occipital cortex is removed the habit is totally lost. It can be reacquired, but this takes about as many trials as were necessary in the first instance. Removal of no other part of the cortex has this effect. This demonstrates a localized cortical participation in this habit of peculiar character, and if the nature of this participation can be discovered we may have the key to the secrets of cortical function on the rat's biological level.

The anatomical connections between the thalamus and the occipital cortex which are probably involved in this behavior are shown in greatly simplified form in Figure 50, diagram III. In addition to the thalamic arcs shown in diagram II there is a cortical loop connected with the thalamic arcs, as the electrician would say, in parallel. Both circuits are open. It is clear that in the absence of the cortical loop the thalamic connections are adequate. It is equally clear that if in the initial training the cortical loop is employed, its further participation in the reaction is essential. What function, then, does the cortical loop perform? We have no satisfactory answer to this question.

One may approach the problem indirectly from several directions. Let us look at it as a problem in

energetics, in the dynamics of cerebral function. The animal body, and the nervous system in particular, may be regarded as a very complex mechanism for the transmission and transformation of energy. The sources of this energy are largely internal, reserves of potential in unstable equilibrium. When this equilibrium is upset, as by an external stimulus, there is an immediate readjustment tending to restoration of equilibrium, typically by an overt act of some sort, such as entering the maze to secure food.

If the natural innate reflex apparatus is adequate to resolve the situation, the reaction is consummated immediately with minimum of energy, as happens when accessible food is placed before a hungry rat. In a more complex situation for which no ready-made innate apparatus is provided, such as the selection of a lighted alley, the necessary nervous circuits must be in some way set apart and re-integrated, that is, "made-to-order," before the reaction is automatized. This may be done by the method of trial-and-error, as already outlined. This is biologically a much more expensive process than the direct reflex response, and the organic reserves are heavily drawn upon. In the absence of cortex the thalamic reserves are adequate for this reaction. But when cortex is present the anatomical organization is such that the cortical reserves are tapped and the cortex becomes a more or less important source of the energies employed in the laborious process of automatization of the habit.

This hypothesis does not imply that the thalamic connections drawn in Figure 50, diagram III, are not employed in the learned reaction, but evidently under the conditions postulated they are incapable of carrying the reaction through unaided. Cortical reinforcement continues to be indispensable. As has already been brought out, there is no evidence that in the process of automatization of a habit the cortical loop, if once developed, is eliminated by overtraining and the reaction short circuited through the thalamus. Accordingly, if the visual cortex is removed from such an animal, the brightness-discrimination habit is lost. Effective cortical reinforcement of this habit is a function of a particular part of the cortex only, namely, the occipital cortex, probably because here alone are the direct anatomical connections between the visual centers of the thalamus and the cortex.

Of the actual nature of this process of cortical facilitation or of the mechanism employed, we have no conclusive experimental evidence. But the line of approach to the question of cortical participation in trial-and-error learning which has just been sketched seems to be congruous with the whole trend of physiological work with the nervous system. In particular, the conception of physiological gradients and physiological dominance as developed experimentally by Child (1924) and as applied theoretically to the nervous system by the writer (1924) presents interesting possibilities. Transmission of excitations in nervous

or any other protoplasm seems to pass from regions of higher excitability and more active metabolism toward less active regions, and regions of greater activity are physiologically dominant over regions of lower activity in so far as these regions are in physiological relationship through protoplasmic conductors.

If now the occipital cortex is bridged into a nervous circuit involved in a brightness-discrimination reaction, the activation of this cortex liberates the local reserves of cortical nervous potential and this field immediately becomes the dynamic center of the entire neuronic system involved. The occipital cortex now dominates the entire circuit as its dynamogenic center, and the removal of this cortex disrupts an equilibrated system, so that the reaction as a whole fails despite the fact that the thalamic connections are still intact.

This analysis of the situation is not at all inconsistent with the fact that the habit can be acquired *de novo* in the absence of the specific visual cortex of the occipital pole. In this case the energy necessary is drawn from some other source, perhaps wholly thalamic, perhaps also from other parts of the cortex than the visual area, or the corpus striatum. But the visual area is evidently normally the most available source of this energy, so that if the behavior pattern is established with this area intact, its removal disorganizes the pattern.

On this view one would expect the habit to be more



readily acquired when the cortex is intact than after loss of the visual area, but under the conditions of the experiments reported this is not the case. The explanation of this remarkable fact is not brought out in the experiments under consideration. In all of these experiments rats with partial destruction of the cerebral cortex seem to acquire the simple trial-and-error habits here under consideration not only as readily as uninjured rats, but in every type of case with fewer trials and fewer errors. Lashley has discussed this question. As he says in one place (1920, p. 91), "The experiment seems to prove too much!" He points out that in some of the kinesthetic-motor tests the conditions of the experiment are such as actually to favor animals which are depressed or partially paralyzed as a result of the operations. In the case of the brightness-discrimination experiments this does not seem to be true, and yet even here animals deprived of the visual cortex may learn the habit in about half the number of trials required by normal rats. The number of cases involved here is small and the difference might disappear with larger numbers, yet the uniform presence of this peculiar feature suggests interesting problems which at present can be discussed only theoretically.

The facts reported seem to be inconsistent with the conception of the dynamogenic function of the cortex as developed above. But this function is not the sole factor operative in cortical activity, and it

must be considered in its physiological setting. It is probable that the visual cortex plays some part other than mere facilitation of subcortical activities which has not yet been brought to light. In the acquisition and execution of a brightness-discrimination habit there are many factors other than the time employed and the number of trials and errors, and at present these alone have been reported in detail. Lashley suggests, "that more complex habits involving diverse sense organs may demand coordination of distant portions of the cerebrum and that the visuo-motor habit dealt with in this study is too simple to give a typical picture of cerebral function" (1921*a*, p. 277; see also 1924, p. 270, n. 47). Elsewhere he calls attention to the fact that even in these simplest brightness-discrimination habits other than visual systems are involved. This perhaps will provide the key to the problem.<sup>1</sup>

In this connection we must bear in mind that even the simplest discriminative reaction involves the use of a very complex neuromuscular mechanism, and the cortical activity is perhaps a relatively small part of the learning process here under consideration. The brightness-discrimination habit can be acquired in the

<sup>1</sup> Study of human cases (like those of Holmes and Lister, 1916, and Riddoch, 1917) has revealed the great complexity of the cortical representation of vision, with evidence of separate differentiation of cortical apparatus for the different sectors of the visual field and for form, color, and movement within this field. How far such differentiation has gone in the brain of the rat is unknown.

total absence of the visual cortex. When the visual cortex does participate its activity is influenced by everything else that is going on in the cerebral cortex as a whole, that is, by the total situation at the moment and by cortical memories of previous experience. This participation may facilitate this particular learning process, or under other conditions it may delay it or block it altogether.

Cortical participation in learning may involve associational neurons whose axons have very wide distribution, and the destruction of some particular cortical field which may have been involved in the initial learning evidently does not prevent the effective participation of other uninjured neurons in the process of relearning. In this sense we may agree with Lashley (1926) when he says:

No part of the cerebral cortex is better adapted for the formation of any particular habit than is any other. Any anatomically continuous cerebral area may serve the learning function provided it presents sufficient mass. This must mean that in a problem situation the effects of stimulation irradiate to all parts of the cortex. As the habit is established there comes into being a definite structural modification having topographical position and capable of destruction by brain injury. The learning process is independent of locus, whereas the mnemonic trace or engram has a definite localization.

It must be borne in mind that so simple a statement of cortical function, if admitted at all, can safely be applied only to a brain as simple as the rat's, and here only for the very circumscribed aspects of simple

habit formation brought to light by the experimental procedures adopted. The normal rat's total behavior under other conditions may involve cortical activities of quite different sorts with more precise localization in space of the nervous connections involved in both the learning process and the stabilized mnemonic patterns.

In view of what we know of cortical function in animals higher than rats it may safely be assumed that an act, whether of learning or any other, in which the cortex participates is a very different act from one performed wholly by the subcortical apparatus, even though under some simplified experimental conditions the overt behavior may seem similar in the two cases.

The presence of uninjured cerebral cortex may actually retard learning a very simple habit by reason of the complication of the process through intercurrent cortical associations from other sensory fields. But when such cortex does participate the act is a *better act*, at least from the standpoint of its adaptability to changed conditions in the future where this type of experience is a factor in a new adjustment, as Professor Carr has called to my attention. He says, "The cortex not only enables an organism to acquire a response to a given object, but a response adapted to that object in a given situation." The animal may thereafter vary its response to this object according to the external environment in which it occurs and the internal condition of the body at the moment. This

is what we mean by saying that cortical activities are more plastic than subcortical acts, even though the latter may be more quickly established. The functions of the cortex must not be evaluated from a single point of view, or with narrow outlook, as would be the case if the rate of establishment of a new habit were used as the only criterion of cortical efficiency.

Evidence has already been presented (p. 77) that at the inception of well-differentiated cortex it appears as three distinct sheets, each with its own characteristic physiological pattern of subcortical connections. It was pointed out that the distinctive intracortical functions probably involve the interaction of these physiologically diverse cortical areas. With the great increase in the complexity of anatomical and physiological specificity of different cortical areas manifested by even the lowest mammals, the co-operative action of these areas doubtless becomes progressively more significant. In short, some localization of function within the cortex is probably the distinctive feature of normal cortical action, even in its reinforcement and facilitation of lower behavior patterns. The studies of vicarious function (1922), however, do seem to indicate some measure of unlocalizable cortical facilitation in residual parts of the cortex after removal of the specific areas which are physiologically colligated with particular learning processes.

The argument as developed here for the functions of the occipital cortex might be applied with but little

change to the frontal areas on the basis of experiments already summarized (pp. 185, 189). But since the available evidence for cortical participation in learned reactions is clearer and more detailed for the occipital cortex than for the frontal cortex, it does not seem necessary to review the latter in this connection.

Still another aspect of cortical function has been much exploited by the physiologists, namely, its inhibitory action. There is evidence, both in lower and higher mammals, of inhibitory action of some sort, but the experiments here under consideration shed little light upon this aspect of the question, for they are ill adapted to separate it from other factors.

The cerebral hemispheres do exert some sort of inhibitory influence, even as far down the scale as the frog. Decerebrate frogs show stupor and lack of "spontaneity," and this is sometimes ascribed to excitation by the operation of specific cerebral inhibitory fibers—a very lame explanation, as Pike (1909, 1912) has pointed out. Burnett (1912) has published some experiments which are interesting in this connection. He found that under natural conditions normal frogs catch more flies than decerebrate frogs; but if a normal and a decerebrate specimen are confined together in a glass dish and flies are introduced the flies are generally caught by the decerebrate frog. The explanation is that the normal frog is distracted by the unfamiliar surroundings and devotes his entire energy to escaping from confinement. The decerebrate frog,

being reduced to a condition of imbecility by the operation, has none of the inhibitions of cerebral origin ("fear reactions"), and the lower reflexes have free and unhampered play. Unfortunately, in these and in most other experiments on decerebrate frogs no precise information is given as to how much brain tissue was removed.

In reality, the cerebral influence in the case of the normal frogs is probably not an inhibition in the ordinary sense of the term. It is more likely a distracting activation of lower centers from the cerebral hemispheres which blocks the elemental reflexes by interference on the lower levels. Upon decerebration this interference is eliminated. The stupor and lack of "spontaneity" of completely decerebrate mammals may result from the loss of these same dynamogenic cortical influences, but acting in a still different way upon the lower centers, as we shall see in a moment.

Evidently the case of the partially decerebrate rats is very unlike that of the wholly decerebrate frogs, and no direct comparisons can be made. Yet in both cases the intact cerebrum may exert a type of regulatory control over lower reactions which is lacking after injury. The normal healthy rat is frisky, enterprising, and inquisitive. A part of this activity is undoubtedly mediated by the complex intracortical association fibers passing between those various cortical fields which are colligated with specific sensori-motor

systems. Upon extensive injury to any part of the cortex these associational patterns are more or less impaired, their normal equilibrium is disordered—a diaschisis effect (von Monakow). The cortex no longer excites the lower reflex patterns, diverting them now in this direction now in that as the play of intracortical associations shifts in response to momentarily changing external and internal conditions. The older and more stable elements of the action system are, accordingly, relieved of this sort of distraction, and the subcortical apparatus of simple trial-and-error learning already sketched is free to work out a new stable behavior pattern more directly and rapidly than in the case where normal cortical associations are continually intervening.

It may be conjectured further than in normal rats the cortical facilitation of the visual conditioned reflex is brought about by a differential inhibition of the irrelevant random exploratory wanderings and general friskiness by a process of “drainage” or cortical “induction” (p. 59) which tends to concentrate the entire available cortical energy upon the visual cortex when this is activated from the receptive field, that is, by the unequally illuminated maze. In ourselves we would say in a similar situation that cortical activity converges upon the matter in the focus of attention. In the rat this cortical effect is doubtless transient and evanescent but so effective when operative that the removal of the visual cortex disrupts the habit.



If, however, the visual cortex (or, in fact, any other area) is removed before training is begun, all cortical associations are temporarily in abeyance (diaschisis), and we get neither the facilitation of the visual habit locally from the visual area nor the distractions of the subcortical learning process arising from "free" cortical associations. The result is that subcortical processes may be automatized more rapidly than before. The residual cortex is, moreover, still able to exert a non-specific and unlocalizable reinforcement upon all lower activities, including the thalamic learning of the maze. If the *entire* cortex is removed, this non-specific reinforcement also ceases, the dynamic equilibrium of the lower reflex patterns themselves is thereby disordered, and the animal passes into stupor and decerebrate restlessness.

On this view of the situation the supposed inhibitory effect of the cerebral cortex resolves itself into a differential dynamogenic cortical influence. This is partly specific and phasic (p. 120), acting upon particular subcortical functional systems while these are in process and tending to depress all conflicting activities either by withdrawing available nervous energy from their apparatus of control or by equal activation of agonist and antagonist systems with resulting stasis. It is partly a general and tonic activation or reinforcement of all lower reflex systems. Upon removal of the visual cortex the specific phasic activa-

tion of learned reactions is abolished. Upon removal of the entire cortex the general tonic cortical effect is abolished. The operation has not stimulated inhibitory fibers, as some have supposed; it has removed the sources of tonic activation which normally are always operating.

The experimental and the anatomical lines of evidence converge in support of the conclusion that in the rat the non-specific tonic action of the cortex plays the major rôle, the specific phasic influence being relatively subordinate. The wide extent of the excitable cortex, its incomplete differentiation from the somesthetic cortex (which is presumably chiefly kinesthetic in the rat) and from the underlying corpus striatum, and the extirpation experiments all agree in substantiating Lashley's belief that in the rat "it is probable that the stimulable cortex and the corpora striata have alternative motor functions" (1920, p. 126) and that the leading function both of the excitable cortex and of the residual 50 per cent (more or less) of cortex after partial decortication is to supply a substratum of facilitating impulses of postural and tonic character (1924, pp. 274, 275).

In man the relative importance of phasic and tonic influence of the cortex upon behavior is probably reversed. One can agree with Lashley (1920, p. 125), "The rat has very primitive cerebral organization but I doubt that this justifies the assumption that there is any fundamental difference in cerebral mechanism

between the rat and even man"; but only in the light of a remark appearing lower on the same page, "The differences between the rat and the apes are scarcely greater than those between the apes and man."

It all depends upon what we mean by "fundamental difference." The difference is certainly significant, and it seems to me to consist in part in the relegation in the human brain of some of the tonic and postural influences to non-cortical (striatal, cerebellar, etc.) mechanisms and the tremendous amplification of the phasic influences of intentional control through processes intrinsic to the cortex.

The preceding argument is perhaps difficult to follow because several different sorts of cerebral activity are enumerated in a single catalogue, and it is not made plain just how these processes are actually related in normal function. The difficulty is in part inherent in the problem. No single formula is adequate, and the path of progress is strewn with derelict theories discarded because too simple to fit more than a selected few of the known facts. Lashley says (1924, p. 275):

Recent work in general tends to emphasize the complexity of neural functions. We must hesitate to ascribe an exclusive or precise function to any neural structure, for the evidence points rather to the view that observable behavior is always the product of the interaction of many neural systems and that the function of any system is dependent on its temporary physiologic relation to other systems.

And again:

The statement that every act of the intact organism involves the participation of every neuron within the central nervous system is probably no more of an exaggeration than are the extreme theories of precise localization of function or of isolated conditioned reflex paths.

The appeals here made to cortical reserves and latent or potential nervous energies may seem to some to be vague or even mystical veils for ignorance of actual organization. But the evidence, both anatomical and physiological, upon which these references rest is adequate. True, our knowledge of details is meager, but the general mechanisms available are known sufficiently for our purpose. This theme will not be elaborated here, for the significance of cortical reserves in behavior will later be discussed in detail. I wish to point out now, however, that this conception of the dynamogenic rôle of the cortex in trial-and-error learning by the rat seems to be in general accord with Lashley's view of cortical function as I understand it (1922, p. 65; 1924, p. 272; 1926), though we would perhaps work it out in detail differently.

In summary, we find the clearest evidence for cortical participation in the rat's learning by trial-and-error. In some of its aspects this participation is definitely localized in specific regions, this localization being dependent primarily upon the topographic distribution of particular systems of thalamo-cortical sensory projection fibers. There is also evidence

(Lashley, 1922) that the cortex may participate in these reactions in general and apart from any specific local differentiation.

It is probable that in the simplest cases both the local and the unlocalized cortical participation are fundamentally manifestations of reinforcement, facilitation, or activation of the thalamic apparatus, with inhibitory (or pseudo-inhibitory) and other factors not clearly brought out in the experiments here under consideration.

In other animals some simple forms of learning by trial-and-error are clearly exclusively subcortical functions and some of these may be so in normal rats. In some of the cases where the cortex has been shown to participate it is quite possible that the physiological modification of nervous pathways correlated with the acquisition of the new behavior pattern and the process of learning considered as a structural change in the organization or "set" of the nervous connections are essentially thalamic. In this case, the learned activity as a behavior pattern is not neurologically a cortical pattern at all but a thalamic pattern, and the essential part played by the cortex is of a quite different sort.

Lashley (1922, p. 64) considers the possibility that the habits which he has investigated are learned wholly at subcortical levels, and he very properly rejects it. The cortex does participate, in some of the cases at least. But even so, the specific local mechanism

whose "set" gives us the new behavior pattern may not be represented in the cortex. This would be true, probably, of only the simpler trial-and-error habits. In more complex behavior the initial learning pattern is cortical as well as thalamic and in higher animals perhaps exclusively cortical in some cases.

The cortex of the rat contains projection centers (apparently ill defined at their borders), each with characteristic subcortical connections and each with specific functional significance. To this extent cortical localization of function is definitely established. This cortex is not physiologically equipotential. There is, moreover, evidence that some cortical influence of a very generalized character (probably reinforcement, tonic activation, or facilitation of some sort) can be exerted upon subcortical activities in non-localizable ways.

In the more complex forms of individually acquired behavior the intrinsic functions of the cortex apparently involve co-operative action of several physiologically diverse cortical fields mediated by the association fibers. In the rat this associational tissue is for the most part knit in with the projection centers as defined above. There is no evidence of extensive areas of purely associational cortex such as are so characteristic of higher brains, nor does the rat exhibit any behavior requiring the use of such associational mechanism.

It seems probable that the rat's cortex exerts a

phasic and a tonic influence upon lower behavior patterns, with the latter predominant. In higher mammals, especially in man, some of the tonic influences are taken over by non-cortical mechanisms and the great enlargement of associational tissue is correlated with corresponding increase in the amount, complexity, and directive control of the phasic influences. Intentional control of behavior and the solution of problems of conduct by what is commonly called "insight" are dependent upon the efficiency of these highly specific and yet very plastic intrinsic functions of the associational cortex. We shall next inquire somewhat further into the nature of these processes and their organs.

## CHAPTER XII

### THE FRONTAL LOBES

*Without an extended discussion of the anatomical details of the central nervous system, we may fall back upon the axiom—agreed to by physiologists, pathologists, and anatomists—that “movements, not muscles, are represented in the cerebral cortex.”*

—F. WOOD JONES

WE have now analyzed as best we can with the data available the learning process and its mechanism in lower vertebrates. We shall next sketch in outline the probable history of the elaboration of this mechanism through the vertebrate series to its culmination in man. The tremendous enlargement and complication of this mechanism as we pass from the highest living brutes to the lowest surviving races of men is indicative of a gap in the phylogenetic series of wide extent—a gap which up until now has been only partially filled by paleontological and archaeological discoveries. No attempt will be made here to outline this unwritten chapter of evolutionary history, but we shall touch very lightly upon some of the differences between the organization and functions of the cerebral cortex as we find it in lower mammals and in the higher members of this class.

The analysis of the preceding chapters seems to



support Lashley's conclusion that in the rat the dominant functions of both the cerebral cortex and the underlying corpus striatum are dynamogenic. But, as already pointed out, this cerebral reinforcement, unlike the cerebellar, has a differential quality. The various parts of the cerebral cortex are structurally and physiologically unlike, and this dissimilarity is of two sorts whose significance in behavior is very different.

First, the primitive cortical areas, that is, the projection centers, differ fundamentally from one another in their subcortical connections. Each is knit in with a different complex of more ancient architectural patterns of the brain stem. Whatever dynamogenic or other influence these projection fields may exert upon subcortical behavior patterns, it differs physiologically, depending upon which cortical field (optic, olfactory, or whatever) is prepotent in the process; and this, in turn, seems to depend primarily upon which sensory system is at the moment physiologically dominant in the lower centers. Thus, in learning a brightness discrimination, at the beginning the difference in illumination has no special significance in the behavior, but as the learned reaction becomes automatized the brightness difference becomes the factor which alone can release the appropriate behavior and so in cortical participation in the act the visual cortex acts as the trigger upon which the visual stimulus must play.

Second, the cortical projection centers differ in their internal structure and in the ways by which they are connected with one another. These differences are minimal, indeed scarcely evident, in reptiles. In the lower mammals they are more evident. The olfactory cortex (archipallium) is sharply set off from the rest, and its various parts have attained highly specialized organization. The neopallium is much more uniform in structure and doubtless also in function. Yet it is not equipotential; there is obviously a preferential relation of each ill-defined projection field with some particular lower sensori-motor system.

In lower mammals the various parts of the cortex are much more closely knit together by associational fibers than in any reptiles, as shown by the enormous increase in the underlying white matter. This is scarcely visible in reptiles; in even the most primitive mammals it is very massive. This implies that the mammalian cortex is much better adapted to act as a whole, and in its simpler reinforcing action one part seems to be about as good as another, as Lashley's experiments demonstrate. But the limits of this equipotential facilitation are quickly reached, and the differential functions of the parts come into play in most normal cortical activities.

In the smaller marsupials and rodents the cortical charts already presented show that most of the neopallium is occupied by the projection centers, while

the intervening fields are small and poorly differentiated. The outgoing fibers, as well as the incoming sensory projection fibers, make direct connection between their respective projection centers and sub-cortical parts. There is no clearly differentiated "motor cortex" through which integrated cortical functions are discharged by a final common path, the pyramidal tract. A part of the cortex is electrically excitable, and from more or less of this field pyramidal fibers descend to lower motor centers. This tract is small and so far as now known it is concerned only with certain types of kinesthetic activity, not with other sorts of cortical function.

In these forms cortical control of behavior is largely effected through dynamogenic or tonic action upon lower mechanisms of adjustment. This action is chiefly extrapyramidal. Phasic action, or intentional control, through the pyramidal system (cortico-bulbar and cortico-spinal tracts) is at a minimum and indeed is so slight that experiments hitherto reported exhibit it scarcely at all. In man, tonic control of the sort seen in the rat is in part localized in the corpus striatum and so perhaps is capable of acting independently of the cortex, and in part it is preserved as the functions which are normally discharged mainly through the extrapyramidal fibers. These leave all parts of the cortex, and particularly the association centers, as cortico-thalamic, cortico-rubral, cortico-pontile, and other extensive systems of fibers.

In primates, extrapyramidal fibers may retain and indeed amplify the specific relationship to visual reflexes which is so obvious in the rat, and this visual-motor cortex is electrically excitable. It has been shown that, though electrical stimulation of points in the occipital and frontal (premotor) lobes of the primate brain is followed by movements of the eyes, nevertheless this movement requires about twice as much time as that evoked by stimulation of the oculomotor centers in the precentral cortex. No motor projection fibers enter the pyramidal tract from these other excitable areas, nor is the longer time required for the response from these areas due to the transmission from them to the precentral motor cortex, for if the latter is destroyed by the excision of the frontal pole of the hemisphere the motor response is still present. The extrapyramidal oculomotor system is evidently physiologically different from the pyramidal system, being apparently more directly concerned with certain cortical reflexes.

In the following discussion our attention will be directed especially to the phasic activities of the cortex, to intentional control of behavior, which, as already pointed out, differs from the tonic control in that the intrinsic cortical mechanisms are competent to redirect the "natural" course of the innate and habitual behavior sequences in patterns not previously organized and stabilized.

Lashley (1924) has shown that surgical removal of

the electrically excitable cortex of monkeys is followed by temporary motor deficiency with great weakness, from which, however, there is nearly perfect recovery within a few weeks. Complicated problem-box habits acquired before the operation are found to be but little impaired after full recovery from the effects of the operation. These very important observations and similar ones made by others, as well as clinical observations on human cases, necessitate some recasting of formerly prevalent views of cortical functions, especially the part played by the excitable areas.

Lashley's conclusion is that this cortex in all animals is part of the kinetic mechanism for reflex control of posture and for maintenance of excitability of lower motor centers. He believes that

a normal function of the stimulable cortex is to supply a substratum of facilitating impulses which act in some way to render the final common paths excitable by the more finely graduated impulses, descending from the cortex by extrapyramidal paths and producing the finer shades of adaptive movement. In other words, impulses descending from the precentral gyrus do not initiate the finer adaptive movements through the lower motor neurons, but only "prime" these cells so that they may be excited by impulses from other sources [1924, p. 274].

This way of looking at the matter seems to be justified by the facts which Lashley brings forward in support of it. But there are other factors which do not fit into this scheme. In rats, destruction of the

excitable cortex results in little obvious change in the ordinary behavior or in acquired habits except those involving rather complex kinesthetic adjustments. In primates, this operation causes severe, though temporary, impairment of all intentionally controlled behavior and in man this effect is much more severe and enduring.

This suggests that in the rat the behavior tested involves a minimum of intentional control and that the excitable cortex is largely concerned with dynamogenic influence which is non-specific except in so far as it is most closely linked with kinesthetic reactions. In higher animals, on the other hand, intentional control bulks larger in the total behavior and the excitable cortex and pyramidal tracts are differentiated as its chief (not exclusive) efferent mechanisms.

In proportion as this type of control is amplified the premotor cortex of the frontal lobe is elaborated. This cortex seems to be concerned, in part at least, with the organization of the results of cortical associational processes in terms of the specific synergic systems of muscles whose excitation is necessary for the execution of the acts intended in purposeful movement. That is, it is physiologically as well as anatomically premotor. Its extent and complexity are proportional to the range of variety and flexibility of pattern of behavior in its motor aspects. It is significant that in hoofed animals and carnivores, where

the actions of the limbs are chiefly automatized locomotor movements, the premotor cortex is very small; but in all primates, from the lowest to the highest, where there is greater mobility of the whole body and especially of the limbs, this cortex is vastly greater proportionally and the central (Rolandic) fissure is pushed far backward in the hemisphere (Elliot Smith, 1924; F. Wood Jones, 1916, p. 162).

The exact nature of this premotor organization is by no means clear. It may be similar in principle to that of some lower centers of motor co-ordination. In a quadruped the reflex co-ordination of locomotor movements of the limbs is partly effected in segmental spinal centers, for bilateral adjustment of a single pair of limbs, and partly it is in the brain stem, for adjustment of the proper rhythm of fore and hind legs (Laughton, 1924). The apparatus of running, walking, and galloping is structurally present as permanent preformed neuromuscular mechanisms in the subcortical apparatus. Which (if any) of these will be activated is determined elsewhere in the nervous system. When the proper button is pressed one or another of these mechanisms is activated and the proper co-ordinations of movement follow automatically.

The various parts of the excitable cortex of a primate ("arm area," "leg area," etc.) are connected in one-to-one relation with particular subcortical centers of motor co-ordination. Each is a "button"

which can be pressed to activate some particular coordinated system of lower motor neurons. Now, the premotor cortex seems to be related to the excitable areas in somewhat the same way that the mesencephalic centers of locomotion are related to the spinal centers. That is, the premotor centers determine which excitable areas will be activated and in what sequence. But the premotor centers differ from the mesencephalic centers in that, while the action of the latter is rigidly predetermined by anatomically fixed reflex connections, the action of the former fluctuates from moment to moment as it is played upon by nervous impulses from other parts of the cortex.

This, I suppose, is the conventional notion of the action of the motor cortex, and I see no reason for abandoning it in view of the facts which Lashley cites. It is clear, however, that in the past this organization has often been conceived too rigidly.

We do not know the mechanism employed in cortical motor control. It may well be in all cases a differential dynamogenic or facilitating influence of some sort, as Lashley suggests. Certain it is that "impulses descending from the precentral gyrus do not initiate the finer adaptive movements," for this is the function of the total equilibrated action of the cortex at the moment working.

Yet the evidence seems adequate that in the higher primates the precentral cortex in the normal animal does lie in the final common pathway of in-



tentional control of the skeletal musculature. The fact that after extensive destruction of this cortex, with impairment of this control, the ape or man can reacquire more or less of the control temporarily lost is another and a very impressive illustration of the plasticity of all cortical functions. This plasticity is the most distinguishing feature of the cerebral cortex. Stereotyped behavior patterns are largely provided for elsewhere in the nervous system. The educability of the cortex is its *raison d'être*. And this implies that its organization at any time can be readily modified, that established patterns of internuncial association can be replaced by new arrangements, and these in turn by others, as external or internal conditions change.

Instead of assuming, as Lashley in the passage quoted above seems to do, that the cortical control of the finer adaptive movements is effected primarily through the extrapyramidal fiber systems and that the function of the pyramidal fibers is merely to activate or "prime" the lower motor neurons, thus presumably lowering their threshold for extrapyramidal excitation, I would set out from a different analysis of the physiological factors. Tonic or activating influences are exerted upon all behavior by both pyramidal and extrapyramidal systems. The pyramidal systems, in higher primates, serve *in addition* as the final common path for that sort of intentional control which is the resultant of intracortical associations—

for the phasic action of the cortex as an arbiter of conduct.

It is normally the extrapyramidal fibers that exert the chief non-specific tonic or activating effect, whereas the action of the pyramidal fibers is specific and phasic. Phylogenetically, the specific phasic system has developed from the non-specific tonic system. Now, upon loss of the final common path commonly employed by the phasic system—the pyramidal fibers—the plasticity of cortical organization is such as to permit, during re-education, of a reorganization of cortical connections which in a way recapitulates the ancestral history. That is, more or less of the non-specific extrapyramidal fibers secondarily take up the functions of the lost pyramidal fibers, and the phasic cortical activities find a new outlet. An analogous sort of functional readjustment takes place after grafting of peripheral nerves with anastomosis in new patterns, so that we know that the process suggested is neurologically possible.

It is concluded, accordingly, that the “motor cortex” primitively was developed within the field of kinesthetic-motor cortical control as the efferent path for its own type of cortical activation only, just as within the occipital pole there is visual motor cortex within the general visual field. With further differentiation of premotor associational mechanisms, chiefly in the frontal region, the precentral motor cortex became progressively more important as a link in the

chain of neurons which form the final common path for all sorts of intentional control mediated by the cortex as a whole. It is only in the human brain that the precentral cortex and pyramidal tracts approach closely to the fulfilment of this process. And even here they are not in undisputed possession of all efferent pathways of intentional control (Franz, Sheetz, and Wilson, 1915; Oden and Franz, 1917, Franz, 1921).

The frontal pole of the human cerebrum has often been regarded as in some special sense the organ of the higher or more abstract intellectual faculties (Bianchi, 1922), but for this view there seems to be no adequate foundation. The premotor functions of this cortex, however, endow it with very special significance for behavior patterns (Bolton, 1914). A part of this is the organization of efferent cortical discharges into the specific synergic patterns necessary for the phasic control of intentionally directed effort to which reference has already been made. This function is represented in the frontal lobes of all higher mammals, some more, some less, depending on the fineness of the cortical control of motility and the complexity of the acts so directed. Naturally these functions are very highly developed in man as expressed in his manipulative skill, vocalization, and other consciously directed acts. The apparatus in question lies in the intermediate precentral field just in front of the excitable areas.

Now, still in front of this premotor field the human brain possesses an extreme prefrontal cortex which is scarcely represented at all in lower mammals and nowhere approaches the human development. This region is in especially intimate relation with the thalamus through the so-called anterior peduncle of the thalamus, probably by both descending and ascending fibers. Keeping in mind that the thalamus appears to be the organ par excellence of affective experience (p. 145), this thalamo-frontal connection may provide for the addition within the prefrontal field of affective impulses of thalamic origin.

The emotional drive which is so powerful a component of much intentionally directed effort is here knit into the cortical process in the field where motor patterns are in process of fabrication. Affective experience thus co-operates with cognitive experience in shaping the course of action and giving the response its dynamic power and volitional motivation (Tilney and Riley, 1923, pp. 611, 799). This is a very attractive hypothesis, though, it must be admitted, not adequately supported anatomically or physiologically.

It is significant that in many of the reported cases of injury to the frontal pole two classes of symptoms are encountered clinically. These are disorientation in space (inability to find one's way about) and emotional instability. For striking cases of the former, see the papers by Marie and his colleagues (1919,

1924). Tilney and Riley (1923, p. 909) cite the famous "crowbar case" of Phineas P. Gage as illustrative of the type of emotional disturbance which follows frontal-lobe injury. Many similar cases have since been reported.

If the emotional disturbance is especially related with the extreme prefrontal field, as suggested above, this symptom would not be expected to be accentuated following lesions of the frontal pole in infrahuman species, and in fact Franz (1907) did not observe it in cats and monkeys after injuries of this region. Bianchi (1922, p. 185), however, does report modifications of emotional behavior in monkeys whose frontal lobes were injured. Stone (1925) made a special search for modifications of sexual behavior, which presumably has high affective components, after injuries of the frontal and parietal cortex of male rabbits, with negative results.<sup>1</sup>

<sup>1</sup> A more surprising result is that "the loss of the olfactory bulbs either in the young or the adult has no serious effects on his ability to enter into sexual activity."

## CHAPTER XIII

### THE ASSOCIATION CENTERS

*Intelligence has its seat everywhere in the cortex of the brain and in no part in particular. It is, in effect, the sum and resultant of all of the images or representations derived from sensory perceptions.*

—HERMANN MUNK

*I look upon the demonstration that the cortex of the brain is the organ of the higher psychic functions—i.e., the organ of intelligence, in all its parts—as the most important result of my researches.*

—F. GOLTZ

WE have seen that in lower mammals the larger part of the cerebral cortex is occupied by projection centers, each of which is in direct connection by ascending and descending fibers with some particular thalamic reflex apparatus—visual, somesthetic, etc.—or, in the case of the archipallium, with subcortical olfactory centers of the hemisphere and both olfactory and non-olfactory centers of the diencephalon.

Each projection center in these animals probably contains a core of cortex which is nearly purely of projection type, that is, broadly connected by projection fibers with subcortical centers, and surrounding this core there is a marginal zone with fewer projection fibers and a larger number of associational fibers concerned with the correlation of this area with other

cortical fields. The marginal zone is dominated physiologically by its own projection system, it may be visual associational, auditory associational, or some other. These *primitive* associational fields are contiguous with perhaps wide areas of overlap. In higher brains, however, they are separated by *secondary* association centers which are not dominated physiologically by any one system of projection fibers. The secondary association centers have emerged within the cortex in accordance with principles not unlike those which came to expression earlier in phylogeny in the emergence of the true correlation centers of the brain stem (thalamus, etc., see p. 50) out of a more primitive and inflexible arrangement of the primary reflex centers.

In the further analysis of the secondary associational mechanisms these may be considered from two standpoints: (1) On the motor side with reference to the number and variety of the synergic patterns of muscles to be innervated. This factor seems to determine the size, number, and arrangement of the association centers in premotor territory. (2) On the afferent side with reference to the ways in which the sensory complexes are worked over in the cortex, correlated, integrated, and resolved into motor complexes—in other words, the apparatus of sensual fusion and resolution so as to activate the particular motor apparatus adapted to give the response appropriate to the situation. This factor seems to de-

termine the size, number, and arrangement of the association centers in other than premotor territory. In the archipallium the organization is different.

As we pass from the lowest mammals toward the higher the projection centers become more sharply defined, structurally more dissimilar from one another, and physiologically more evidently indispensable links in the chains of higher associational processes. The intervening cortex, the associational cortex, is enlarged and differentiated. These cortical areas have been mapped anatomically and investigated physiologically in representatives of most mammalian groups. We shall not attempt to summarize these studies, which would require a large volume. The process of cortical differentiation culminates in the human brain, where upward of fifty cortical areas can be distinguished by differences in anatomical structure.

Now, apparently in the rat the cortex has reached a stage of elaboration at which cortical facilitation of lower activities is exerted more or less differentially, but the intrinsic functions of cortical association are poorly represented as compared with higher mammals. These latter appear to grow *pari passu* with further elaboration of the associational tissue interpolated between the projection centers.

Habit formation through repetition and learning by the method of trial-and-error, as we have seen, are not primarily cortical functions, though they may



be facilitated by the cortex. On the other hand, the central analysis of a situation such that overt trials may be eliminated and the animal attacks the crucial element of the problem directly, identifying the key to the lock without aimless fumbling—this sort of behavior is clearly dependent upon a type of cortical organization with which the rat is very poorly endowed.

With the elaboration of cortical associational tissue emancipated from direct domination by some particular subcortical sensori-motor systems (as all projection and primitive associational centers are), mechanism is available for the recombination of innate or habitual behavior patterns in hitherto unexperienced ways with facility and dispatch. As has been happily said, the animal now exhibits "insight" as contrasted with "at-sight"; he not merely looks at the problem, he looks through it to the solution.

The earliest appearance of this sort of behavior in the animal series has not been identified. In fact, the designation of any such point in psychogenesis would necessarily be arbitrary; for this insight is not a new and unique function. It represents merely the transfer of more and more of the factors of behavior from the overt and explicit to the introvert or implicit bodily mechanisms. And the associational tissue of the cerebral cortex is unmistakably the chief apparatus employed.

Anyone who has lived on terms of intimacy and cordial friendship with a good dog will be inclined to

credit him with some measure of this sort of insight. In some of his behavior he seems to show various short-cuts from tedious trial-and-error to more direct understanding of key factors in problem solution. But the evidence for such an opinion is, so far as I know, still in the "anecdotal" stage. If the dog learns only by trial-and-error, some of the processes are certainly much foreshortened.

It is, in fact, very difficult to devise experiments with desirable quantitative measurements adequate to yield crucial evidence. The learning curve has been appealed to here, learning by insight giving a steeper curve than learning by overt trial. But so many other factors may enter that this method is still of uncertain value.

Yerkes has published well-controlled observations on monkeys and the orang-utan (1916) and chimpanzee (1925) that seem to give clear evidence of this sort of learning. In Köhler's fascinating account (1925) of his observations upon chimpanzees much additional evidence is supplied.

With the problem of insight and intentional control of behavior in mind, a review of the countless experiments that have been made on rats' behavior discloses very few which are well adapted to reveal this sort of behavior, even if rats are competent to perform it.<sup>1</sup> Most of the laboratory experiments so far re-

<sup>1</sup> A necessary physiological background for such studies is accurate knowledge of the natural spontaneous behavior, that is, the internally excited activity (see p. 314).

ported are adapted to test sense physiology, stereotyped reflex and instinctive behavior, and learning by trial-and-error better than inventiveness. Mazes and problem boxes of the usual sort do not provide the best setting for bringing out inventiveness, as Köhler has pointed out. The animals claw or bite or dig or run about aimlessly. Whenever a rat, as sometimes happens, at the beginning of an experiment goes directly to the latch or other key-part of the apparatus and begins to claw or bite it, it is suggested that previous experience in a somewhat similar situation is being utilized, and this might be a first step in the development of intentionally controlled behavior. This much is common to all sorts of learning. Cortical learning is apparently roughly proportional to the complexity of associations that can be made without the assistance of completed overt trials, but we have no satisfactory quantitative studies which confirm this supposition. So far as I know there is little unambiguous evidence that the rat under experimental conditions shows this type of behavior.

Köhler's observations on chimpanzees do reveal such behavior, apparently of a rather high order. Some laboratory workers may discount his results because they are not supported by statistical tables, graphs, and kymographic records. But the very nature of inventiveness makes such standardization difficult. Doubtless such observations can be made under conditions of more satisfactory laboratory con-

trol—and will be. In the meantime, the record stands as a very illuminating contribution to animal behavior.

Domesticated animals and caged wild animals are likely to exhibit their innate and habitual reactions to better advantage than any inventiveness of which they may be capable, for here they lead a routine existence. If the distinctive cortical functions are superposed upon these stereotyped activities, the added functions will naturally be invoked only when the mechanized activities prove inadequate, that is, under conditions which make unusual demands upon the resourcefulness of the individual and where this resourcefulness is not inhibited by unaccustomed situations. Such conditions are more likely to be realized in the desperate struggle for existence in nature than under laboratory conditions. Yet controlled observations are indispensable, and the problem is to devise experiments that will meet these exacting requirements.

Domestication for many generations is sure to alter the whole behavior complex of a species, and probably in the direction of reduction rather than enhancement of initiative and resourcefulness. The behavior of tame albino rats is undoubtedly simpler and of more routine character than is that of their wild relatives, the Norway rats, and Donaldson (1924) has found corresponding changes in their brains, the brains of the wild rats being heavier relative to bodily weight.

Sugita (1917-18), in a detailed comparative study of the cortex of albino rats and wild Norways, found a greater average thickness of cortex in the wild rats and some other differences. The total number of nerve cells in the cerebral cortex of the two races is about equal, but the average size of the individual cells of the wild rats is notably greater. The mature brain of the Norway rat contains more gray matter than does the brain of a mature albino of like weight. It is highly probable that domesticated albino rats actually use their cerebral cortex far less than do wild Norways, and further studies of the minute differences in cortical texture of these two races are very desirable.

In an endeavor to find a simple objective and quantitative indicator of the capacities of animals with different grades of cortical elaboration, Hunter (1913, 1917, 1924*a*, p. 8) performed his well-known delayed reaction experiment. He trained rats, dogs, raccoons, and young children to make simple associations, as between the appearance of a light with food, and then determined the length of time that may elapse between the presentation of the sensory stimuli and the response before the association is lost. The rats, the dog, and the youngest child (at thirteen months and two and one-half years) were unable to make the association unless they were permitted to consummate the reaction within a few seconds after the application of the initial stimuli, or unless they utilized persistent motor cues, such as the preserva-

tion of an orienting attitude of the body during the delay. The raccoons retained the memory of the stimulus for twenty-five seconds (possibly by unobserved motor cues), and the six-year-old children could react perfectly after more than twenty-five minutes.

These observations might well be extended with critical study of the motor cues and other observable phenomena during the delay. If rats can execute the delayed reactions only with the aid of overt motor cues or an enduring "set" of the body musculature and children can react perfectly after a delay of twenty-five minutes, it is suggested that there is probably some internal apparatus which preserves the cue—an apparatus not available to the rats and the youngest children.

The association centers of the cerebral cortex provide such a mechanism, and the known structure of the cortex supports this interpretation. The establishment of an association or conditioned reflex of the type used by Hunter is possible in the absence of the cortex, as has already been pointed out; but to hold the association, as it were, in suspense, without releasing it into motor channels is apparently beyond the capacity of the rat even with the aid of his cortex. The cortical activities cannot be far dissociated in time from the subcortical. The more complex and more impressionable human cortex makes such associations more quickly, and it can retain them without the necessity of consummating them as overt move-

ment. The dissociation of cortical functions in time as well as in space (pp. 80, 259) has been perfected.

These are the observed facts. A theoretic explanation which is consonant with what we know of cortical organization might take this form. The establishment of an association or conditioned response in the cortex activates certain associational neurons in a particular pattern. If the reaction is consummated, this pattern is left in a slightly more favorable form for reactivation when the stimuli are repeated (the familiar physiological principle of facilitation of path by use—the organic basis of habit). This is a property of all nervous circuits. But the associational centers are so organized that a similar structural change, or cortical set, may be preserved even in those cases where a cortical association does not eventuate in overt action. The essential feature of the functional pattern will reappear when the neurologic pattern is reactivated in any way, by stimuli either outside or inside the body.

This is the organic basis (engram) of a cortical memory. What is preserved is not an image in the psychological sense; it is simply a change in the structural organization, static not dynamic (Cole, 1925). Its psychological significance is not necessarily different from that of the muscular set of a rat or raccoon in Hunter's delayed reaction experiment. And yet this ability to inhibit the overt expression of a reaction and still preserve centrally a permanent rec-

ord of its incipience in usable form marks just the difference between the explicit and the implicit types of behavior—in brief, the difference between brute and man. Apes and some other higher mammals apparently exhibit recognizable stages in this transition.

Quite apart from such speculative considerations it is clear that the mnemonic functions of the associational cortex are fundamental. The impressionability of this cortex and its retentiveness of patterns once impressed upon it underlie all of its mysterious capacities as the organ of the distinctly human functions, capacities which are clearly recognizable in the anthropoid apes and which are probably incipient in dogs.

This more complex organization of the association centers not only enormously increases the flexibility of the action system by permitting a greater variety of types of connection between the various projection centers under present stimulation, but it also brings to bear upon the now acting stimulus complex memory traces of previous successful reactions in similar cases, thus immeasurably broadening the field of efficient correlation—traces which can on occasion be called into play, even in the absence of any present sensory stimulation by changes in internal state.

One of Köhler's observations shows how important this retentiveness is in the development of inventiveness. Young chimpanzees generally quickly pick up a stick to pull a banana to them that lies just



beyond their reach. But the stick and the banana must *both lie within the field of view* or the stick will not be used. If the stick is so placed that the ape cannot see it and the fruit at the same time the stick is ignored. The ape may turn away from the side of the cage which faces toward the fruit, see the stick, even handle it, but he does not associate it with getting the banana unless the stick is so placed that the fruit is visible also. Older and more experienced animals were advanced far beyond this simple stage of inventiveness, and would sometimes stop in the midst of a long series of fruitless trials to obtain an objective, hold an attitude of indecision, and then suddenly dart away for a ladder or some other tool which was quite out of sight at the time.

The young chimpanzee's use of a stick which is in plain view as a tool to secure a banana is typical of what Lloyd Morgan in 1894 called "intelligence" as distinguished from "reasoning" and what Hobhouse in 1915 called "practical judgments" and what Carr (1925) calls "perceptual-motor learning." This type of behavior probably makes up a large part of the conduct of many men. This is probably what Hunter means by "sensory thought," as distinguished, on the one hand, from the unconscious or obscurely conscious learning process through gradual acquisition of a physiological habit by trial-and-error, and, on the other hand, from reasoning processes involving symbols, ideas, concepts, or other abstractions.

The stimulus-response physiology when broadly interpreted is an adequate basis for an understanding of most subcortical nervous activities. It also provides the activators for all cortical functions. But the intrinsic processes within the human cortex go beyond these simple principles. In the associational fields we have the machinery for registering in static form the structural modifications (engrams) left by the activation of every cortical associational pathway. Every such associational pattern which has once been activated seems to be preserved, set as on a trigger, ready to be activated when some related or congruous system of subcortical activities again overflows into the cortical projection centers—the conventional theory of cortical memory. (For further analysis of this situation see Hunter, 1924*a*, p. 19, and Dashiell, 1925.)

These reactivated cortical patterns (memories) knit in with the lower sensori-motor systems at the moment in action and serve as the “deciders” of conduct. When many such mnemonic vestiges have been laid down in the structural organization of the cortex, these may be so related that the excitation of one may activate another and so arise trains of cortical activity which, though initiated from the outside, are themselves strictly intrinsic to the cortex and may continue as intracortical processes indefinitely—the conventional theory of free cortical association.

The cortical areas into which nervous impulses are

discharged from lower centers of diverse sorts are arranged in mosaic or switchboard patterns. Localization in space of these "sensory projection centers" is an indispensable feature of the cortex. There is also a mosaic localization of peripheral motor fields of some sort in the Rolandic zone. Beyond these fields mosaic localization of cortical functions is of very doubtful validity. Certain of the larger fascicles of associational fibers, like the cingulum, are probably laid down in innate patterns, but what functions they serve we do not know. It is not improbable that the precise functions of the more disperse associational pathways of the cortical white matter are determined within the postnatal experience of the individual. Every enduring memory vestige involves the linkage in some way of a very complex system of intracortical neurons, and every time the cortex is activated from lower centers more or fewer of these established patterns are quickened.

The function of speaking my friend's name when I see his face is certainly not localized among thousands of similar "memories" in any simple mosaic pattern that can be mapped on the cortical surface. It is localized, no doubt, in a very different way, for it involves the reactivation of systems of neurons articulated in definite anatomical patterns which may ramify from pole to pole of the cerebral hemisphere. The systems of neurons colligated with the other memories ramify equally widely, and many of the neurons involved in

one memory may also be involved in a dozen other memories, but linked in different patterns.

This seems to be a plausible way of looking at the organization of cortical patterns of association, and it is as incompatible with any map of surface areas to each of which some definite and circumscribed psychological function can be assigned as it is with the older phrenological maps of mental "faculties." It is not incompatible with clinical maps of particular loci whose injury produces some pathological disturbance of particular associations, for association fibers of like sorts or of related functions do apparently tend to run in common fascicles.

All of the telephone subscribers residing in some one city block may be cut off by breaking some particular cable anywhere of its length or by wrecking some particular section of the switchboard in the exchange, but we do not think of the process of normal telephony as localized at the point where the damage was done.

The first serious attempt to determine by direct observation the pattern of functional localization in the brain was made by the founders of phrenology,<sup>1</sup> the value of whose pioneer work has since been submerged in charlatanry (Elliot Smith, 1924, p. 138). Long before the days of Gall and Spurzheim, even

<sup>1</sup> F. J. Gall, 1825. *Sur les fonctions du cerveau*. 6 vols. Paris. See also F. J. Pike, 1912. A defence of the "new phrenology," *Science*, n.s., vol. 35, pp. 619-622.

from the dawn of speculation about the nervous system until now, numberless attempts have been made on grounds largely speculative to localize somewhere various complex "faculties" or "senses" or associational types as psychological entities. Only recently an eminent medical practitioner announced the exact cortical localization of the "moral sense" on the basis of surface scars on the heads of a few delinquents. The futility of mosaic localization on the surface of the cortex of small areas supposed to perform complex associational functions should by this time be apparent.

There is unquestionably mosaic localization of certain physiological functions in the human cerebral cortex. The projection centers are definite areas within which specific systems of projection fibers make their cortical connections in switchboard fashion. But neither these centers nor any sector of the intervening associational tissue can be thought of as performing any one of the distinctively higher cortical functions in isolation (Pike, 1913). The clinicians' maps of the aphasias, etc., represent (in some of the cases) true pictures of vulnerable points of certain associational complexes. But most of the charts of functional localization of psychological or other complex functions are misleading fictions.

The projection centers, I repeat, are definitely localized in mosaic patterns. Surrounding each of the sensory projection areas is a zone of associational cor-

tex in whose activities the functions of the contiguous projection center are dominant. Thus, there is visual associational tissue surrounding the visual projection center, and so on. But no particular visual memory, or visual image, or visual consciousness whatever, can be thought of as residing there. For each of these things as actually experienced is a complex involving much more than excitation of the specific visual nervous system. Otherwise, there would probably be no awareness of it at all. Our conscious experience—even the simplest of it—is of total situations, not of hypothetical simple elements, whether of sensation, or affect, or any other logical abstraction (Herrick, 1913, 1915).

After thus endeavoring to fortify myself against the inevitable misunderstanding, I venture to present the accompanying schemata of the development of the cortical apparatus of association (Figs. 51, 52, 53). I hasten to explain that the projection centers (shaded areas) are actually localized in space and the contiguous primitive associational tissue necessarily conforms roughly with the same mosaic pattern. The remaining parts of the diagrams, and particularly the secondary associational tissue, *D*, must not be thought of as capable of being projected upon the brain surface in definite geometric or mosaic patterns.

On the sensory side the apparatus of cortical resolution of afferent complexes may be conventionalized as illustrated. Starting on the plane of cortical

development of such a lower mammal as is pictured on page 153 (Fig. 35), the projection centers with their contiguous primitive associational fields are arranged as in Figure 51. In the associational zones there is sensual fusion, not only of present complexes of stimuli, but also of vestiges of previous similar activities which have been fabricated through facilitation of path and the retention of these acquired structural alterations—cortical memories, conscious or unconscious.

On the plane of "perceptual-motor learning" (Carr) the relations of the primary projection centers and of the primitive associational field may be conceived as diagrammed in the figure. The sensory or primitive associational fields,  $A'$ ,  $B'$ ,  $C'$ , are directly connected by association fibers so that the excitation of one may be communicated to all of the others, and all of them are directly connected with the motor field,  $M$ . There are also motor pathways (not indicated) passing down from each of the primitive associational fields directly to lower subcortical centers. Simultaneous excitation of associational fields  $B'$ ,  $C'$ , may result in the establishment of a  $B'$ - $C'$  complex with a stable modification of structure by facilitation of path so that later reactivation of  $B'$  alone will be followed by activation of  $C'$  also. We now have an associational memory. Any two or more of the primitive association centers may be thus related. In such a system, repeated experiences with

the bell through the senses of touch, hearing, and sight may result in a cortical set of such a character that the activation of any one of these sense organs

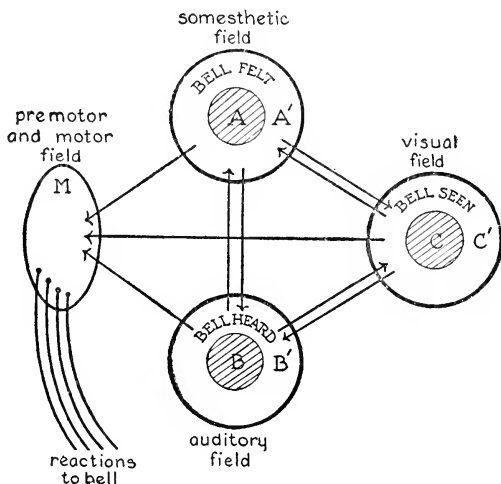

FIG. 51.—Diagram of the relations of projection centers and primitive associational fields in a lower mammal, illustrating the courses of intracortical nervous impulses in reactions to a bell felt, heard, and seen. The projection centers (*A*, *B*, *C*) are shaded. The primitive associational fields (unshaded) in reality overlap the projection centers and also one another. Feeling, hearing, and seeing as psychological processes are not to be thought of as separately localized in the associational fields indicated, but each of these fields includes a complex physiological process in which the designated sensory excitations are predominant.

by the object may call forth a reaction in which all of the other sensory components are represented in memory. The probability is that the response in each case will be to the total situation as presented at the moment in sensory stimulation and memory revivals.



If there is any awareness at all during the process, it would probably be of the total situation in the con-

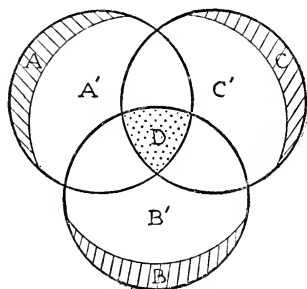

FIG. 52.—Diagram of the relations of projection and associational centers in the higher apes.

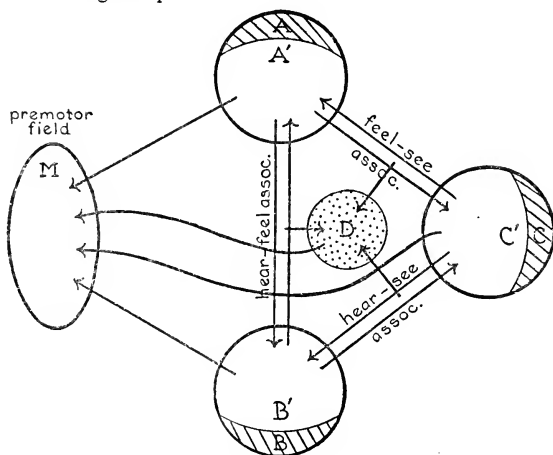

FIG. 53.—Diagram of the relations of projection and associational centers in the human brain.

crete—bell-to-be-avoided, bell-as-a-food-call, bell-to-be-investigated, etc., with a definite emotional coloring.

Now let us suppose that these primitive association centers are enlarged so that their interrelationships are much closer and there is a broader area of overlap, as illustrated in Figure 52. The associations may be more intimate and more complex. There is a cortical field of overlap, *D*, which is common to all of them. This field must not be thought of as localized in some particular spot as drawn, but as representing a more complex type of interrelationship of primitive associational fields. The field *D* is not dominated by any single sensory system. It is frequently activated in complex situations where *A*, *B*, and *C* are simultaneously excited, and any features which are common to all of these experiences will affect the field *D* in each case.

With the further separation in space of these fields and the interpolation of still other hierarchies of associational centers between them we reach the stage of organization of the human brain which may be crudely diagramed as in Figure 53. Here the association center *D* may be conceived as modified by features common to a large number of different complex experiences. This, again, is an enduring change in the structural configuration or "set" of the apparatus. Whether a psychological "image" is involved is not a relevant matter from the present point of view. The significant thing is that the associational complexes thus fabricated are not bound to particular sensori-motor experiences; they are free from specific

contextual relations and so may have a general or even universal significance (Carr, 1925, p. 179).

Thus the idea of "bell" as distinguished from the experience of a particular bell, its color, tone, or shape, may arise every time this structural configuration of parts is activated. We now have before us the anatomical mechanism competent to record and preserve elements of experience which have been abstracted from many diverse concrete sensori-motor activities—in short, the apparatus of ideation, abstraction, symbolic thinking.

## CHAPTER XIV

### SUMMARY OF CORTICAL EVOLUTION

*It is an essential prerequisite of consciousness that there should be a period of delay or tension between the receipt of an impression and the determination of the consequent movement.*

—JOHN FISKE

*The function of consciousness is to dislocate in time the reactions from sensations.*

—C. S. MINOT

AT the risk of tedious repetition we shall now assemble in review the conclusions to which the facts and inferences recounted in the preceding chapters seem to lead. In the interest of simplicity and brevity these conclusions will be enumerated dogmatically as a series of propositions; but it should be borne in mind that they are not equally validated by unambiguous observation and experiment. They represent in part a program for future research rather than a digest of equally authenticated facts.

1. In fishes the beginnings of the cortex are found in correlation centers which do not differ in principle structurally or functionally from other similar centers of the brain stem. The approach toward cortical structure follows change in the nature of the afferent impulses discharged into these centers. Cortical differentiation tends to be retarded by the dominance

of any one sensory system of afferent fibers and promoted by physiological diversity of the afferent fibers.

2. This cortex does not appear until (in reptiles) the underlying reflex centers of the cerebral hemispheres (septal and strio-amygdaloid complexes) are greatly enlarged and complicated. The dorsomedial (hippocampal) cortical sheet is intimately related with the medial olfactory area and septum; the dorso-lateral (pyriform) sheet is intimately related with the lateral olfactory area; the dorsal sheet (general cortex or neopallium) is intimately related with the non-olfactory part of the corpus striatum, but is primitively more detached from lower reflex centers than are the other two cortical sheets. The underlying basal or subcortical centers related, respectively, with the three cortical sheets perform very diverse functions of reflex correlation. The resulting physiological diversity of the overlying cortical sheets is a prerequisite for the performance of associations of cortical type.

3. The specific intrinsic functions of the cortex comprise intracortical correlations between these diverse cortical areas. These functions are superposed upon those of the subcortical reflex centers, though intimately knit in with them. The cortex is not activated except through the lower reflex centers, and primitively it acts synchronously with them.

4. Cerebral centers within which cortex is differentiated are more or less detached in space and physi-

ologically isolated from the reflex centers and the great lines of through traffic of the brain stem, and the degree of this detachment is one of the factors affecting the differentiation of the cortex.

Reflex responses usually follow immediately upon presentation of their adequate stimuli, and their central adjusting mechanisms are elaborated within the relatively direct lines of conduction employed (medulla oblongata, midbrain, thalamus, corpus striatum, etc.). But cortical functions are in larger measure delayed reactions and individually acquired controls redirecting and recombining the innate reflex and instinctive patterns. The introduction of large masses of higher correlation tissue concerned with delayed reactions within the innate reflex apparatus would tend to distort the reflex patterns and interfere with their prompt and efficient independent action when this is desirable. The addition of associational tissue outside of these deeper centers leaves their local activities unimpaired no matter how extensively the overlying cortical fields are developed, a point that has been called to my attention by Professor Landacre.

This detachment of the cortex may be compared with that of a large switchyard of a great railroad center which is set off to one side of the main lines of through traffic. Where many trunk lines of railroad intersect switch tracks must be provided for the through trains which pass from one line to another,

and these must be built into the main lines of through traffic. The reflex centers of the brain stem are thus developed at the nodal points of conduction where the pathways of the great reflex systems intersect. But the cortex is set apart from the intersection of trunk lines of reflex conduction in a separate field. The through traffic of the basal centers may go on without interference by the shifting, sorting, and redirection of nervous activities which take place in the cortex, or it may be held up while the results of cortical activity are assembled and discharged into the trains of reflex and instinctive behavior.

5. This implies that intrinsic cortical activities in their definitive form are also dissociated in time from the immediate reactions through which they are activated (Minot, 1902). There is, however, no evidence that this is true of the simpler forms of cerebral cortex. The temporal dissociation of cortical from subcortical functions appears clearly only in those more complex kinds of cortex where much associational tissue is interpolated between the more primitive cortical projection centers.

6. The diversity involved in associations of cortical type is such that cortex never develops within or associated with a single center which is physiologically dominated by some one functional system (olfactory, optic, or any other), though it may develop in relation with several such centers conjointly. In fact, the simplest well-differentiated cortex known

(that of reptiles) develops simultaneously as three sheets of superficial cells, each of which is related with a different complex of subcortical correlation systems—hippocampal, pyriform, and general cortex. In other words, there can be no cortex without some degree of cortical localization of function.

7. Primitively, cortical activity is invoked, not to produce action, but within action, first checking inappropriate reflexes and then amplifying, redirecting, recombining, or otherwise improving upon the immediate responses which have already been initiated in the subcortical reflex centers. The primitive cortex exerts a regulatory control upon behavior in process.

The cerebral cortex ordinarily is not activated by simple uncomplicated nervous impulses coming in directly from the periphery,<sup>1</sup> but it is called into play by activities going on in the lower correlation centers and it articulates with these as going concerns. Sense impressions are received and combined in subcortical centers, and there resolved into actually operating or incipient motor responses before they can get through to the cortex at all. The cortex is not reached by these nervous impulses if the situation is one for which the organization of the lower centers is adequate, that is, if a standardized reaction of reflex or instinctive type gives a satisfying result. Otherwise, collateral efferent

<sup>1</sup> The anterior pyriform cortex is a conspicuous exception to this rule, which is discussed on pp. 26, 86.



pathways from the lower centers to the cortex are activated and the cortex participates in the reaction.

From this it follows that the nervous impulses that reach the cortex are the resultants of the interaction of more or less complicated subcortical dynamic patterns, some of the participating peripheral sensory systems being reinforced and others wholly or partially inhibited. The nervous impulses that stream into the cortex are overflows from subcortical centers whose simpler reflex outlets are inadequate. These nervous currents may, accordingly, be thought of as carrying a quale of subcortical origin in that they are already organized into incipient reflex patterns. It may be that this quale is what gives subjectively to some cortical activities of man their affective coloring and also (sometimes) an impulsive tone or "drive" (Herrick, 1913).

8. The cortex in its most primitive form seems to exert a dynamogenic influence upon the activities of lower centers. This is in part a non-specific (equipotential) tonic effect upon such activities as may be in process, comparable with the tonic influences of the cerebellum; in part (and progressively more so in higher animals) it is a selective phasic action upon some particular functional components of lower reflex patterns, namely, those which are the key factors in problem solution by the conditioned-response method. These functions are shared by the corpus striatum, and in higher mammals (especially man) the

non-specific tonic reinforcement is largely striatal and the specific phasic activation involved in intentional control of behavior is almost exclusively cortical. Cortical reinforcement or facilitation as seen in man is of very different type from that of the corpus striatum, and it employs a quite different mechanism.

So important is the combined dynamogenic effect of cortical and striatal reinforcement of lower activities that in all mammals complete destruction of both of these parts of the cerebral hemispheres leaves the animal in a state of profound depression and stupor, with perhaps decerebrate restlessness due to loss of the inhibitions to be mentioned immediately.

9. The cerebral cortex from its inception exerts more or less inhibitory influence upon subcortical functions. In the simpler learning processes of rats there seems to be a differential activation of some key factor of a subcortical learning process (as of the visual component in a brightness-discrimination reaction) which in effect draws off all available cortical energy, leaving other and irrelevant sensori-motor processes relatively enfeebled so that they are subordinated. The effect is the same as if a specific inhibitory action were exerted by the cortex upon the inappropriate movements. This theoretic interpretation has no direct experimental support, though it seems constant with the known facts. It may be suggested, further, that all inhibition is in reality a differential activation, the mechanism being in some

cases simply the "drainage" phenomenon to which reference has just been made and in other cases this effect supplemented by positive activation of two antagonistic motor mechanisms so that their interference blocks all reactions of non-adaptive sorts.

Whatever may be the unknown mechanism of inhibition, the cortex of higher mammals certainly does exercise repressive as well as activating influences upon more elementary components of behavior.

In situations where the simpler immediate reflex responses to stimuli fail to give satisfaction, resulting in either interference and stasis within the lower reflex centers or futile random movements, the excitations overflow into the cortex. The immediate effect of cortical activity is inhibition of the lower non-adaptive movements. A man "stops to think"; an ape similarly pauses in a waiting attitude until he "sees through" to a possible indirect way to reach the objective (Köhler). These inhibitory functions of the cortex play a major rôle in all those human traits that are described as self-control, "poise," and deliberation.

10. But inhibition is at the most only a first step in cortical function. The positive contribution to behavior made by the cortex of higher mammals is evidently recombination of the lower reflex units in patterns determined not only by the stimulus complex now acting but also by knitting into this complex the relevant personally acquired mnemonic vestiges of

previous allied reactions. The efficiency of this latter process is dependent upon the mass of the cortex itself and the nature of its internal organization. It is present (so far as evidence now goes) in an exceedingly generalized form, if at all, in reptiles and lower mammals. The ability to retain such organic memories of complex individual experiences (as contrasted with those acquired by the more tedious trial-and-error method) seems to be correlated with the presence of highly developed associational tissue outside of the cortical projection centers, this culminating in the human brain.

These mnemonic functions of the human cerebral cortex are perhaps its most distinctive properties upon which depend all the nobler human faculties. In situations where the immediate responses of the innate reflex and instinctive apparatus of the brain stem prove inadequate to determine the appropriate response or where these simpler systems interfere so as to inhibit all reaction, there is stasis and summation in the lower centers, the longer cortical arcs are activated, mnemonic traces of previous allied reactions here laid down are quickened, and the dilemma is resolved in the light of former experience.

It is not to be assumed that the memories to which reference is here made are psychological images, mythical subconscious entities, or so-called unconscious mind. Just what the mechanism is we do not know, but the assumption that best fits the observed

facts is that every cortical association pattern when once activated leaves the synaptic thresholds (or whatever may be the apparatus of facilitation of path by use) in a different structural arrangement or "set" which makes the reactivation of these neurons in this particular pattern easier than it was before. The thing which is preserved is static, a changed structural arrangement of parts.

11. The features so far considered appear to be characteristic of some, at least, of the infrahuman types of cerebral cortex, some more, some less. The human cortex presents these features and some very significant additional structural patterns. The differences between the larger anthropoids and man are relatively unimportant except those related to the cerebral cortex and the behavior.

The wide gap between the highest living anthropoid and man has not been bridged. The enormous increase in the size of the human cortex is chiefly in the associational fields. Here, then, is to be sought the structural organization upon which depend human culture and the progress of civilization. The feature which most distinguishes these associational fields from the rest of the cortex is their greater wealth of strictly intracortical associational connections. This is obvious anatomically. With this are probably joined physiologically: (1) a greater impressionability or susceptibility to those structural changes (engrams) to which reference has already

been made which preserve the effects of particular patterns of associational activity—that is, better memory—and (2) greater mobility of the elements so that residual effects of previous cortical associations can be recombined in new patterns with greater facility—that is, better learning power. These two functions are, of course, mutually interdependent.

12. The dynamogenic influence of the cortex which seems to play a dominant rôle in rats and similar lower types becomes not less but more important in higher forms. But its character changes radically with the elaboration of the intrinsic apparatus of cortical association. As already mentioned, the non-specific or generalized tonic influence seems to be exerted in part by the corpus striatum and in part it is preserved in the extensive extrapyramidal systems of fibers which descend from the cortex to motor centers of the brain stem. Within the cortex a quite different apparatus of energy reserves is built up, which comes to expression in behavior as a phasic (not tonic) control of intentional behavior. The importance of this theme is so great that it will be treated more at length in a later chapter dealing with the vital reserves.

In the preceding analysis the attempt has been made to present generally accepted facts as observed, supplemented in some cases where observed evidence is meager by inferences which seem congruous with the known facts. But probably few of these proposi-

tions will be accepted by everybody as a true and adequate statement of the case. Adequate they certainly are not. Some of the necessary qualifications have been cited in the earlier chapters and some further general appraisal will follow.

Since human conduct is shot through with conscious participation in the behavior patterns, it is impossible to ignore the psychic factors in a scientific analysis of these patterns. We must, accordingly, pay some attention to the relation between the unconscious and conscious components of human experience and to the apparatus employed in these two kinds of vital function.

## CHAPTER XV

### THE SUBCONSCIOUS

*Because intellectual crimes have been committed in the name of the subconscious is no reason for refusing to admit that what is not explicitly present makes up a vastly greater part of experience than does the conscious field to which thinkers have devoted themselves.* —JOHN DEWEY

*The precise nature of my conscious reaction upon today's experience depends not on what I can formally recollect of past experience, but on the form of equilibrated unity which is the result of past experience in its progressive reaction upon my nature.* —C. L. HERRICK

IT seems to be a common belief that all of the functions of the cerebral cortex are manifest in consciousness and that so-called unconscious cerebration is subcortical activity. There is no proof of this nor of the other prevalent idea that only cortical activities are involved in consciousness. In fact, we have reason to believe that simple affective experience is largely if not wholly thalamic.

The conscious act appears to be the efflorescence of a long series of biological processes whose roots strike deep down into ancestral impulses and instinctive actions, and there is no ground for doubting that even the higher association centers may on occasion be involved in reactions which do not reach the conscious level at all. Such unconscious processes may leave mnemonic vestiges which, when linked with



other cortical patterns, can be incorporated into truly conscious complexes.

Many experiences of average normal persons suggest that cortical associations of the most desirable sort may arise quite independently of voluntary attention or any other conscious effort. I well remember a certain mathematical problem of years long past whose solution was of great importance to me. After working on it unsuccessfully the greater part of several successive nights, I went to bed thoroughly exhausted and discouraged. Immediately upon awakening the following morning I found myself in possession of the proper method (which was really very simple). Certain associational linkages which could not be voluntarily made in the fatigued state "came of themselves" either during light sleep or immediately upon awakening.

Experiences of this sort are indeed so common that cautious men when confronted with important problems frequently say, "I will sleep over it before announcing my decision."

It is a familiar observation that our choicest thoughts, our happiest literary conceits and fantasies, and at times in the course of scientific investigation our most fructifying hypotheses thus come of themselves without consciously directed effort. Not only the inspirations of artistic genius, but also that insight which envisages fundamental laws of nature, are, like happiness, most often attained by indirection. In-

spiration, whether artistic or scientific, is like the Kingdom of God; it cometh not with observation, for, behold, the Kingdom of God is within you.

But, let it not be forgotten, it does not come at all unless there is already something of value within us. To most of us most of the time the primroses by the wayside mean no more than to Peter Bell; they are yellow primroses and nothing more. To Alfred Tenyson a flower in the crannied wall can unfold "what God and man is." Nature speaks her varied language only to those who hold sympathetic communion with her visible forms; to the casual passer-by she is dumb. A receptive mind, saturated with experiences of nature which have been absorbed perhaps in solitary places by running waters or lofty mountains or perhaps accumulated during years of painstaking observation and experiment in the laboratory—a mind thus generously furnished with raw facts and naïve experiences is a hospitable land for the kingdom of science, the kingdom of art, the Kingdom of God. And the king and his retinue of ministers may come uninvited at any time when the barriers of self-determination and conventionalized thinking are down. The slothful mind is vacuous even in reverie.

My sleeping porch faces to the east, and I love to lie with curtains drawn aside so that if awake betimes I can watch the miraculous rebirth of the dawn, proclaimed with spectacular flames of color or unobtrusively stealing out from black night into a gray

day. And then, when "it's murky overhead," I love to turn over for another nap. During these moments of half-wakefulness strange fantasies come and go, usually foolish vagaries leaving no solid residue of any value to the wideawake consciousness. The inhibitions of the conventionalized thinking to which we have schooled ourselves are partially lifted, yet without that complete abandonment of rational control characteristic of the night-time dream. Detached fragments of previous experience seem to come together, as if by mutual attraction, often in bizarre patterns and occasionally in flashes of real originality that endure the scrutiny of rational analysis in full daylight.

After all, the real springs of inspiration are internal, though the raw materials are drawn from outside sources, from experiences of some sort. These materials are stored away, often unsorted, but somehow they seem to assemble themselves in some kind of order, and a new experience may pull a trigger which releases one of these unconsciously assembled or undeliberated trains of memories fabricated in a new pattern which perhaps we could not have invented by purposeful ratiocination. Or in fantasy, when the ordinary controls of formalized thinking are relaxed the data of experience may reassemble in accordance with laws of subconscious association and appear to flash into consciousness as if communicated to us from the outside.

Authors almost without number have confessed

that their best plots, and often the very words of the story, have been delivered to them ready-made without conscious effort of their own. These "brownies of the brain," these willing sprites who work for us without coercion and without reward, have been acknowledged by many of our most gifted writers—Scott, Maeterlinck, and Barrie with his M'Connachie, "the unruly half of myself, the writing half." Stevenson in his chapter on "Dreams"<sup>1</sup> even goes so far as to tell us in all frankness just which parts of Dr. Jekyll and Mr. Hyde were dictated by his "brownie" and what parts he laboriously wrought out himself.

We may approach the problem of the significance of the unconscious operations of the brain and their influence upon consciously directed processes by way of what goes on in the search for a forgotten name. Direct voluntary effort fails. I have sat for fifteen minutes exploring every reminiscence of a person trying to find a loose end of a memory thread that would lead back to the missing association. Then, upon turning to something else, the name flashes into consciousness unsought or the mind relaxes into aimless reverie and after a time turns spontaneously to the missing name by way of some trivial incident quite forgotten so far as voluntary recall is concerned.

So creative imagination works, assembling past experience in new patterns never before conceived by

<sup>1</sup> In the volume of essays entitled, "Across the plains with other memories and essays," New York, 1904.

the mind of man, perhaps quite without voluntary effort. The "brownies" that thus work for us in their own way and at times of their own choosing are not under the control of our voluntary efforts. They act "spontaneously." This spontaneity is no new faculty of the human mind; it is the lineal descendant of that capacity for storing reserves of latent vital energies which is expressed even as low down as Protozoa in "overproduced movement," vital reserves, etc., and also in that exuberance of play and reactions in excess of vital requirements to which Ritter (1919) has of late devoted so much attention.

Now, in the cerebral cortex this same capacity to evoke reserves of latent energy laid by during the whole period of past experience comes to superlative expression. These reserves are not merely undifferentiated potentialities of vital energy, like water stored in a high reservoir; they are organized in definite patterns which are stable, just as the time lock of a bank vault is set on Saturday afternoon to release the lock at ten o'clock Monday morning. The time lock does not open the door; the cashier must do that from the outside; but he cannot do it before ten o'clock. Nor are these reserves the mythological gnomes of the Freudian system—"complexes," "censors," or other fabulous monsters without legitimate parentage or scientifically demonstrable nature.

A simpler illustration, perhaps, is a seismograph set to record earth tremors. Ordinarily it lies inert,

motionless; but by virtue of its construction it can so record a movement of the earth as to enable its designer to say that there was an earthquake of considerable violence at 3:42 A.M. about two thousand miles away to the southeastward.

The previous experience of the seismographer with earthquakes and with physical instruments has enabled him to construct a very simple machine with these mystic powers, which to the uninitiated may seem supernatural. But what is latent in the instrument is not an earthquake, nor the image of an earthquake; it is merely certain tensions which have been impressed upon elastic material in such a pattern that when a particular form of external energy is applied the tensions are released, the latent energy becomes kinetic, and mass movement of a definite predetermined character follows.

In the human cerebral cortex the machine and its designer are one. The past experience which is invoked in winding up and setting the machine is the past experience of the machine itself. In short, the automaticity of the seismograph is pushed a stage farther backward and a stage farther forward. Looking backward, the machine was not fabricated by an outside designer; it fabricated itself during creative evolution. Looking forward, the record is not interpreted by an intelligent observer who inspects it from the outside; the intelligence is immanent within the working of the mechanism itself. The operation of

the machine (or some of the operations involved) *is* intelligence.

These, again, are mystic powers which to the uninitiated may seem explicable only through the intervention of metaphysical agencies. And the trouble is that no mortal has yet been initiated into these sacred mysteries.

What shall we do about it? Shall we resign ourselves to the inevitable and say, these mysteries are unknowable? Or shall we gird up the loins of our logical and theological Samsons, equip them with all the armament of metaphysics that they are able to carry (shall we complete the analogy and say, also, with the jawbone of an ass?), and bid them go out and slay the Philistines and conquer the unknowable? From this dilemma there is a third way out that is at least worthy of serious consideration. Why not approach the problem with the usual technique of scientific investigation, namely, assemble all known observed facts that have a bearing on the question and then fabricate hypotheses that are congruous with these facts?

The analysis of this third method of approach to the mind-and-body question may proceed along lines parallel with those followed in our study of the problem of the seismograph. Mention has already been made of the fact that in an examination of the functions of the cerebral cortex considered as mechanism the problem reaches both backward and forward

farther than does this aspect of the question in the case of the seismograph.

The backward view of the rise of cortical functions envisages two fields of very unequal visibility: first, the foreground of the history of the personal experience of the individual; and, second, the background of his whole phylogenetic history. The first field is open to casual inspection, and more careful examination reveals the chain of events which mark the steps in the fabrication of one's equipment of habits, in the accumulation of the data which constitute his knowledge, and in the formation of those mental attitudes and idiosyncrasies that we call "character." A retrospect into the second field, the field of hereditary endowments, requires an ascent from the level of simple observation to the higher ground of biological research with the aid of much optical and other scientific equipment, and the dim horizons of this wider territory have been but imperfectly explored.

The scientific evidence already in hand, some of which has been cited in the preceding discussions, is adequate to reveal an orderly sequence of biological processes whose phylogenetic movements can be followed, in broad outline at least, with a high degree of probability and whose final result is the "original nature," or innate endowments, of the individual man. In the course of his personal career the events of his daily life have been woven into the warp and



weft of this original nature in a tapestry pattern, more or less colorful, more or less comely, more or less exceptional and inimitable, more or less noble.

The experiences which have been instrumental in the elaboration of these patterns of bodily organization are not preserved as such in the body any more than the seismographer's experience of earthquakes is preserved as such in his seismograph; but they have established the organization and "set" of the body so that the individual reacts to new situations in modes determined in part by the structural patterns thus established.

Now in dreams, fantasies, and "free associations" of ideas these structural or relatively static patterns of organization are quickened, perhaps by a passing and unobserved sensory excitation, perhaps by some vascular, endocrine, or other internal change, and being free from the control and inhibitions of our formalized or logical intellectual norms they may follow old lines of forgotten experience, as when the desired name pops unannounced into the mind, or they may recombine in new arrangements never actually experienced, as in invention.

These trains of thought follow "of themselves" as they do, not because we have unconscious minds (whatever that might mean) nor because we have within us a beneficent "brownie" or a malicious demon (say a Freudian "wish"), but because our nervous systems have been so altered structurally by

their previous reactions as to facilitate certain kinds of function when reactivated in any way.

This is the backward view of cortical functions. Recurring to our analogy of the seismograph, it is recalled that this mechanism has a forward or prospective reference in that the observer can use the completed record of responses to earth tremors which are registered upon it to report a distant earthquake in, say, the West Indies and perhaps to predict future shocks. The machine was designed for this purpose and it behaves as intended. We say, the observer interprets the meaning of the record.

In the case of the seismograph the designer and the interpreter are external to the mechanism, but in the case of the cerebral cortex both of these are internal to it; they are intrinsic, not extrinsic. The machine has been fabricated as it is in the course of its phylogenetic and ontogenetic development through its own reactions to external energies and materials; and the machine interprets its own behavior by virtue of this inner design.

It is not some adventitious, detached, or detachable soul or consciousness who, when certain images are formed on the retina with consequent nervous reverberations, says, "This is an outcrop of coal; my experience tells me that coal is a valuable commodity; I will form a company to mine this coal and thereby acquire great wealth." It is the function of the eye to form such images, of the retina to transform them

into nervous impulses, of the nerves to conduct these impulses, of the brain to respond to them in very complicated ways including the reactivation of association centers in patterns long quiescent so that the present excitation sets off a train of associational processes which were established when I first learned of the properties of coal, its commercial value, and the procedures necessary to exploit this value. In just the same way it is a function of the brain to generalize from past and present experiences, to understand how to profit by them, and to determine to do so.

This is the scientific and the common-sense analysis of the facts as we know them. There are many things in this sequence of events that are beyond our present understanding. To a savage the location of an earthquake two thousand miles away with a seismograph seems like magic. To some philosophers the intelligent recognition of a mineral vein as coal of commercial value and the determination to mine the same also seem like magic, and various magical formulas are still current to "account" for the mystery—parallelism, interactionalism, idealism, materialism, etc.—but to the plain man of science the scientific method (with which he is tolerably familiar) points in the direction that I have indicated. It does not promise an ultimate philosophical explanation, for science never attains the ultimate. The intelligent interpretation of the things seen, the resolve to use these things to gain wealth and renown,

and the accompanying sentimental thrills and emotional outbursts seem like the natural workings of an apparatus which is acted upon by certain external stimuli; they are, in short, functions of the body.

The following passage is quoted from my Introduction to Neurology (1922, p. 332):

The dynamic view of consciousness here adopted makes such expressions as "the unconscious mind" impossible contradictions. Either the mental functions are in process or they are not, and unconscious cerebration is not consciousness. This is, of course, not incompatible with a dissociation of consciousness into multiple or co-conscious units, as Dr. Morton Prince so forcibly illustrates (*The Unconscious*, p. 249), though how far in normal men this dissociation may be carried is an open question.

In my life as viewed by an outside observer there is continuity of process, but not necessarily continuity of consciousness. In my own experience consciousness appears to be continuous, of course, because the periods of unconsciousness (as in coma, deep sleep, etc.) do not appear in consciousness; that is, they do not exist for me except as I learn of them by an indirection. In a water mill the function of grinding corn may go on intermittently, though the mechanism is there all the time and the energy is there; but if the water passes from the mill race out over the dam instead of through the water wheel the grinding function ceases. While the mill is at rest changes may be made in the machinery which will modify the character of the grinding when it is resumed, but these changes are not grinding. So in the brain the mechanism of consciousness and the structural memory vestiges of past experience may be present continuously; indeed, these vestigial traces may be linked up in new ways by intercurrent physiological processes. But these things do not constitute consciousness. In fact, a large amount of unconscious cerebration may go on, the end result of which alone becomes conscious.

The aim of physiological psychology is to clarify not only the mechanism of consciousness, but also all of the antecedent and subsequent physiological processes which are, from the standpoint of an outside observer, demonstrably related to the conscious processes. It is possible, moreover, to develop a really scientific introspective psychology in which abstraction is made from all of these mechanisms and the individual experiences alone are studied as given in consciousness. This makes up a large part of general psychology.

In behavior the difference between the parts played by the reflex-instinctive activities of the brain-stem mechanisms and the cortical control may be further illustrated by an example (cf. Rivers, 1922). The regulation of traffic on the streets of a large city seems to go on largely automatically. Pedestrians, motor cars, etc., move in orderly fashion without any directing control because the rules of the road are known to all and are obeyed habitually. Law and custom have fixed these modes of behavior much as innate organization and long practice have established in our own nervous systems at subcortical levels (or at any rate below the level of attentive consciousness) norms of reaction to familiar situations which go on "of themselves."

But at the rush hour in a great city at especially congested corners one will find a traffic officer who signals to each motor car separately when it shall move and the direction to be taken. So in the more complex adjustments of our daily lives the cortical control of every step replaces the subcortical auto-

maticity of the process. Again, if an accident happens at our busy corner, the traffic officer arrests (inhibits) all traffic until a way around the obstruction is found or the wreckage is cleared.

In this analysis we have relegated to the frankly unconscious much of that which in current literature is often called by such meaningless terms as the "unconscious mind." But this unconsciousness is not static; like everything else which is alive, it is dynamic; it may even be creative, as are many ordinary physiological processes. The liver creates glycogen out of its raw materials, and it repeats the process quite uniformly time after time. The associational mechanisms of the brain may combine the same elements of experience over and over again, as when we remember our house number in the telephone directory, or they may combine these elements in unfamiliar or even in quite original patterns. Much of this sort of combination may be done without any awareness of what is going on. Rivers (1922) has remarked very justly, "It would be an advantage, if, instead of speaking of unconscious mental states, we were to speak of unconscious experience." The effects of this experience may later appear in consciousness—or they may not—just as the effects of retinal excitation may lead to a reflex winking of the eyes with or without a sensation of light or any other awareness of the event.

In this connection we must not make the mistake

of regarding consciousness as a simple element which obeys the all-or-none law of nervous physiology. Our awareness may be vivid, intense, and extraordinarily complex, or on the other hand it may be a vague, scarcely recognizable feeling of well-being or malaise, an unanalyzed impulse, or a dimly recognized uninterpreted sense impression. The subconscious (that is, unconscious) cortical activities may flash into consciousness momentarily to be immediately again submerged beyond recall.

The conscious activities of the normal healthy person are integrated into a coherent unity, probably incidental to the dominance of certain systems of cortical and thalamic associations related to the constant streams of incoming sensory impressions from the visceral, proprioceptive, and other so-called organic apparatus of living, the "intimate senses" of Starbuck. These are acting at subconscious levels more or less uniformly all the time, and they emerge more or less dimly into the conscious level most of the time. The rapid fluctuations in the impulses of sensori-motor adjustments to the manifold complexities of the external world do not disturb the unity of this basic conscious experience as a whole.

It is a familiar fact that in dream and reverie there is in perfectly normal people more or less of isolation or dissociation of certain chains of experience from the remainder of the conscious life, a process which may be carried so far in pathological or hypnotic

conditions as to result in complete dissociation of certain components or complexes of experience which among themselves form perfectly coherent unities that remain quite outside the knowledge of the normal personal consciousness. When this is carried to the extreme we have the remarkable cases of dual personalities or co-consciousness which have been described by Morton Prince (1914) and many others.



## CHAPTER XVI

### CONSCIOUSNESS AS A VITAL FUNCTION

*Our judgments are themselves facts which have consequences, and their value depends on their consequences.*

—JOHN DEWEY

**T**WO factors may be recognized in all nature: (1) constancy and uniformity in the lawful relationships of the elements of structure and action; (2) progressive changes in the patterns in which these elements are combined. The second factor appears in all cosmic evolution; and these progressive movements are also lawful.

In organisms we have not merely the perpetuation of specific patterns of structure and behavior throughout metabolism, growth, and reproduction as formulated in our laws of anatomy, physiology, embryology, and heredity, but also progressive change in these patterns—evolution. And let it not be forgotten that the highest biological patterns as well as the lowest conform to these laws.

If the discussion of the higher, that is, the more complex, organic phenomena, including those involving conscious behavior, is to progress on the scientific as contrasted with the metaphysical plane, it is essential that all of the phenomena under consideration be shown to be interrelated as parts of a single natural system. Any break in the chain of lawful or orderly

relationships, the recognition of any epiphenomena not integrally articulated with the cosmos as this is knowable, the injection of any metaphysical dæmons or entelechies into natural processes, these favorite expedients of the philosophically minded when confronted with unresolved problems, merely bar the way to further scientific advance. Whatever justification there may be in philosophy for a pluralistic universe, natural science knows naught of it. The cosmos which we study in experience by the scientific method is a single order, whose manifestations, after experimental analysis, must be reintegrated into a coherent system of interrelated uniformities, whose processes, in short, conform to a single code of laws.<sup>1</sup>

Lawful change in phenomenal manifestations is one of the most fundamental principles of the system of nature, and the determination of these sequences and the formulation of their laws is the scope of evolutionary science. The essential factor in this field of inquiry is not the quantitative determination of relations of matter and energy, for the sum-total of these (so far as present scientific analysis has gone) may be regarded as constant; it is, rather, the patterns in which the units (simple or complex) of structure and behavior are combined *inter se*. The various subdivisions of science have as their materials each a particular group of these patterns of matter and en-

<sup>1</sup> This is not necessarily true in other realms, e.g., mathematics, as MacMillan (1925, p. 97) has pointed out.

ergy—physics, chemistry, physiology, optics, acoustics, etc. These patterns, it is true, may be quantitatively expressed, and are known to be related in mathematically definite orders; one British thermal unit of heat is mechanically equivalent to 778 foot-pounds of mass movement. Though there are physiological processes which as such are not identical with any processes of inorganic nature, yet these may be shown to be compounded of well-known physico-chemical elements; and they do not thereby lose their distinctive physiological patterns.<sup>1</sup>

It is the current scientific belief that all forms of energy are mutually convertible without loss or increment and that these transformations are constantly taking place in accordance with definite quantitative laws, many of which are accurately known. Parallel with this law of conservation of energy there was developed the law of conservation of matter. The chemical fabrications and dissociations of molecules take place in accordance with laws capable of quantitative expression, and the recent analysis of the atom has not yet led to any generally accepted fundamental modification of these laws of quantitative relations of material and dynamic units. Throughout all these transformations of energy and matter we meet countless changes in patterns of combination, but the laws of these changes are knit together in an integral sys-

<sup>1</sup> On the question of pattern in organisms, see Kingsbury (1913) and Child (1921, 1924a).

tem of nature. There is diversity of pattern but no disruption of the unity, no pluralism in the sense of unrelated systems of events or materials. Even in evolutionary history, where the laws of change themselves undergo progressive modification from cycle to cycle, the factors of this progression are intrinsic, not extrinsic, to the evolving cosmos. There is no break in the continuity of the process; there is differentiation, but always through the action of resident forces upon pre-existing material.

Each field of science, accordingly, has its own lawful modes or patterns of structural (static) and functional (dynamic) manifestations, and these in turn are all related members of the total world as known to science. The vital modes (all of them) are thus related with inorganic modes, but without loss of their own differentiae.

The most complex and distinctive of the vital modes are those related with the nervous system—reflex, instinct, and others. And the biologist must regard consciousness (by which I mean some sort of awareness during the progress of bodily functions) as a function of the nervous system in the same sense as are nervous conduction, reflex, and physiological habit. The evidence for this conclusion is of exactly the same sort as that which supports the belief that contraction is a function of muscular tissue, and to the unprejudiced observer it is equally convincing. My brother (1907, p. 213) has written:

If the energist be correct in viewing the phenomena of the physical universe as manifestations of various phases of one universal, indestructible, but convertible energy, and if psychology be correct in asserting that all mental states are acts, and, furthermore, if we are not so blinded by prejudice as to shut our eyes to the overwhelming evidence of the interaction of these two sorts of activities (a fact more certain than any other whatever) then we are driven to conclude that body and mind are phases of one reality—that consciousness is not unrelated to gravitation, but is a part of the same universe of activity.

Certain higher organisms present structures in the cerebral hemispheres not present in the lower and presumably ancestral types, and with these structures are associated modes of behavior equally distinctive. The structure of the cerebral cortex and certain other parts of the nervous system subsidiary to it is related to the behavior type of the animal in question in a fashion which is biologically on a par with the relation of wings of birds to flight. This is beyond question. And the behavior types of mankind (and doubtless of some other animals) are shot through with conscious processes whose causal relationships with the objective manifestations are indubitable. The exclusion of these conscious factors from a total view of the situation as the biologist must study it is scientifically inadmissible, and this procedure can be adopted only by an appeal (usually cleverly masked) to metaphysical, theological, mythological, or other unscientific prejudices, or else as a subtle form of intellectual indolence which, confronted by a complex

problem, seeks to simplify it by ignoring the troublesome factors.

The brain of the chimpanzee has relatively larger projection centers than that of man. The increment in the human brain is almost all in the association centers and their immediate dependencies. This difference in cerebral organization is reflected in the behavior. The human brain can fabricate symbols and abstractions; it can use language, numbers and equations, design machines, bridges, telescopes, and use them. The chimpanzee does not know the meaning of  $y^2 = 2px$ , *and he never can find out*. These symbolic components of behavior we know best introspectively. We use them psychologically. We know objectively the end-results of their action and only a part of the intervening processes. And these psychological processes are real causes of behavior.

We have the clearest scientific evidence that bodily changes are in causal relationship with mental processes and that mental processes do cause bodily activities. Certain drugs which excite or narcotize ordinary protoplasm produce effects on the mind quite comparable with those exerted upon the functions of nerves and muscles, and there is no valid scientific reason for refusing to draw the same inference regarding causal sequences in the two cases. It is recognized in commercial life that certain kinds of mental activity are productive work for which a daily wage is paid. Even a philosopher in the employ of a

university will accept his monthly pay check, for he verily believes that he has earned it. The discovery by a mathematician of a new and "elegant" solution of a recondite problem is followed by bodily changes at once evident to a by-stander, who may characterize them as a "glow of satisfaction"; and it may later be followed by a revolution in engineering practice of great commercial value. A causal sequence which omits the mental work of the computations from this series of events is a scientific perversion.

The belief so widely prevalent (unfortunately even among physicians) that because an event is mental it is negligible or even non-existent as a cause is responsible for much tragic misunderstanding in the practical treatment of mental disease. Imaginary ills are by no means unreal, as is graphically shown by one of Babinski's cases,<sup>1</sup> in which the patient with hysterical (that is, purely imaginary) paralysis of one leg leaned so heavily on the crutch as to cause a crutch paralysis of an arm with organic injury to the tissues. Here we have a mental process causing a functional disorder which in turn is the cause of a physical injury. The cure of the hysterical paralysis may be effected by appropriate mental treatment, but the organic paralysis remains and can be cured (if at all) only by physical agencies.

In developing the thesis that the pathology of in-

<sup>1</sup> Cited by E. E. Southard, *Shell-shock and after*, Boston Medical and Surgical Journal, vol. 179, pp. 73-93, 1918.

sanity can be brought into line with general pathology, Dr. Ford Robertson (1920) remarks that it has been laid down by psychologists that there is no evidence to support the position that mind is a function of the nerve fibers and nerve cells. He says:

On the contrary, it seems to me that there is no definite evidence of its being anything else; indeed, the view that mind is an expression of the functional activity of the brain, or, more strictly, of the association centers, instead of being absurd, is supported by a mass of anatomical, physiological, and pathological evidence that the psychologists are either unaware of or are incapable of interpreting correctly.

The mental processes and their organs, like the muscular and conducting processes, have grown up in individual and racial development gradually and naturally. They do not arise from nothing, nor are they injected into the sequence of natural events from an external non-physical or metaphysical realm.

The natural causal sequence in thinking is unbroken. The causes of my present mental processes are to be sought in previous natural processes, some strictly physiological, some also perhaps introspectively experienced. The results of the mental process again may be other mental processes, as when I "make up my mind" to clear farm land of forest; some physiological, as when I am swinging the ax; some the ensuing alterations of the face of external nature. The mental act is as necessary a link in this causal sequence as are the physiological processes of



nervous conduction, and it has its own anatomical configuration of parts of the reacting nervous system, the same as do the simpler physiological processes of conduction, etc.

Dewey's discussion of experience (1925, chap. i) suggests an instructive parallel between the process of living in general and experience as we have it. All living is interaction between organism and environment, and one of these factors cannot be regarded as more essential or more fundamental than the other, though for special purposes we may fix attention for the moment on one of them. The analysis is logical; in the vital process these factors are inseparable. Similarly, naïve experience is a unitary datum whose separation into subjective and objective is perhaps a later sophistication. Rosenow (1925) has expressed a similar idea in these words:

The distinction between awareness and action is valid logically, but invalid phenomenologically. The distinction has arisen because in the practical exigencies of life we usually describe what we have experienced, not our modes of experiencing—we discuss what we have seen, not the behavior of seeing. The distinction is valid and useful, just as the distinction between the pitch and the intensity of a sound is valid and useful even though the two are inseparable aspects of a single phenomenon.

On the relation between brain and mind, Sellars (1922) says:

I hold consciousness to be physical in the sense that it is an internal character of the functioning brain, though it is not a complete physical thing to be known externally by the sense-

data it arouses. . . . We are so accustomed to think of the brain in the terms of the information furnished by physical science that we mistake its reach and suppose that it exhausts the brain. The truth is that the brain should be thought of as the brain-mind. We impoverish nature by identifying it with the skeleton which science deciphers.

Again I may quote from my brother (1907):

We as souls are indissolubly connected with the rest of the universe and there is no use in attempting to sever what God has united. Finally, therefore, we perhaps see that the psychical differs from the physical as the result of a logical analysis which is possible by reason of our limitation. So long as individuality shuts us up to one point in consciousness, and so long as consciousness seems to require equilibrated energy as a condition of its unity, so long this distinction of subjective (psychical) from objective (physical) will remain in force and will be to us the most vital of all distinctions [p. 212]. Where, then, is the limit of self? It is not for me to draw it. I will not cut the narrow isthmus of flesh which connects me with my twin—the universe [p. 219].

Human consciousness is one of the data of experience, and this experience when examined without prejudice arising from traditional mysticism and in the light of all that we know of the relations of all bodily organs with their functions clearly indicates that my consciousness is a function of my body, or of parts of it, in just the same sense that contraction is a function of my muscles.

Now, as we follow muscles and their functions back in the growth of the individual body and in the

probable evolutionary history of the animal kingdom, we see that muscle has grown up out of protoplasmic organization of simpler, i.e., less differentiated, sort. Contractility is a function of all protoplasm, but muscle as tissue is a later differentiation. The muscular systems as we see them in the human body are new structures, appearing at a definite stage of animal differentiation, both ontogenetically and phylogenetically. But they were not fabricated out of nothing. The origin of this new organic pattern is a natural process and the working of the completed mechanism is also a natural activity.

The evidence is that the organs of the human mind have gradually grown up phylogenetically and ontogenetically in a similar way, by natural process. And the adult working of these organs is similarly a natural process. No mystic forces are involved. Certain combinations of bodily processes (excitation of end-organs, conduction in nerves, etc.) act upon nervous tissue of very special organization (chiefly in the cerebral cortex) whose functions are in part physiological processes observable by the ordinary technique of the physiological laboratory (metabolism of tissue, changes in electrical potential, etc.) and in part directly as subjective awareness while the process is in action.

This is not an "awareness of an awareness," nor of any activity as physiological process (for we do not directly experience nerves as conducting, etc.), nor

necessarily "of" anything else. It is one of the functions of a structure in action, and as such it is as unique and "primary" as is any other function of a specific structure. The "explanation" of the colligation of this particular function with this very specific structure must await the further scientific analysis of the structure-function relationship in general, of that of material and its properties, of the matter-energy relationship.

No knowledge of structure as such ever gives us directly the data from which we can predict its properties or modes of action. This latter comes only by real experience of that action, as has been repeatedly pointed out. "Analysis of structure reveals no reason for behavior and the intelligibility of structure resides in the fact that ends are reached by behaving" (Woodbridge, 1925, p. 409). It is true that, having determined empirically that certain structures and certain kinds of behavior are colligated, we can go on and predict the probable functions (or properties) of other combinations of these structural units, as every inventor demonstrates. But any analysis of these structure-function relationships quickly leads us back to the crude empirical data.

Conversely, the observed behavior as such does not directly give us knowledge of the structure which is behaving. The ends reached may be arrived at by a variety of roads which do not necessarily run parallel. The passengers who arrive at a destination

may perhaps have traveled by very different sorts of conveyances.

It follows that we can attain satisfactory understanding of any natural phenomenon only by a synthesis of its end-result, the processes in their entirety by which this end was reached, and the structural mechanisms which serve as the vehicles of these processes. This is the scientific method.

To conceive that conscious processes are truly functions of the bodies with which they are always associated is the simplest and indeed the only way in which they can be articulated with the general sum of scientific knowledge. And if our insight were not clouded by mischievous metaphysical traditions we should find that the problems concerning the relation of mind and body offer no difficulties which are fundamentally different from those regarding the relation of any organ and its function, of any object and its properties. The body-mind problem, then, resolves itself into an inquiry into the peculiarities of this relationship, its mechanism and *modus operandi*.

These are philosophic questions which the man of science of today may very properly lay aside as outside the field of his interest. On the other hand, the experience of several thousand years of rather fruitless argumentation suggests that future progress is most likely to come through the accumulation by scientific inquiry of further experiential data, facts which permit a reformulation of the problem along new lines.

The ancient problems of the relations of phenomena and noumena, form and substance, matter and energy, things and their properties, organs and their functions, body and mind, are probably all of a piece. The solution is not likely to come by way of further deductive analysis of ancient formulas or any other form of dialectic, but by more searching inquiry into natural phenomena.

If now we claim that in the present stage of scientific advancement the simplest procedure is to regard mind as we know it phenomenally as a function of the body, a property of matter in motion, it should be emphasized that this no more implies an objectionable materialism than does the enumeration of any other organs and their related functions. The philosophical question is merely moved forward another notch to the more general problem of the relation of any object and its properties (Herrick, 1924, p. 302).

Natural science has hitherto been content, for the most part, to assume a stable material substance endowed with properties which in the upshot are merely the behavior of the matter. But further analysis of the supposed ultimate unit of this matter, the atom, has broken it up into smaller dynamic elements—electrons—of which again we know nothing but their properties, that is, their activities. It is true that the masses of these electrons have been quite accurately computed, but mass in its turn is only a name for a behavior. And there seems to be a growing tendency

on the part of many physicists to resolve the old dualism of matter and energy into a simpler but even less intelligible monism of energy manifestations alone. But disembodied energy is a concept which the scientific mind has difficulty in grasping, and one gropes about for a more substantial foundation for the enduring realities of our cosmos.

Certainly we must avoid the error of assuming that matter is more fundamental, more primitive, or more significant than its properties or behavior. This is a natural mistake for those of us who are trained in the methods of natural science, for our experience tends to make us structurally minded (Herrick, 1905). But more recent scientific experience has led to the conviction that our familiar concepts of matter and energy, of material and its properties, are not ultimates; in the end they will probably have to be recast in some way if they are to fit such scientific experience as is now available. But the time has not yet arrived when this recasting can be done in generally acceptable form.<sup>1</sup>

The demand that at this point in the argument we give an accurate and final definition of mind is natural but, after all, unreasonable. Adequate definitions should precede a logical syllogism, but they do not

<sup>1</sup> As illustrative of recent trends in this direction we may cite the "neutral stuff" of Holt (1914), the "movement-continuum" of Reiser (1924), and the philosophic aspects of the quantum theory, relativity, *Gestalt* (Lotka, 1925; Koffka, 1924; Ogden, 1925; Brown, 1925). For still other modes of approach see Sellars (1922), Mead (1925), and Dewey (1925).

come in at the beginning of a scientific inquiry. In fact, the purpose of the inquiry is to make such definitions possible, and they come (if at all) at its close. We certainly are not yet in possession of a final definition of either mind or matter, but we have practical working knowledge of both which is adequate for getting along in the world and for the prosecution of further scientific inquiry.

Awareness, mind, consciousness, are currently used in so diverse ways that one would like to be able to define his own usage unambiguously. My only response to this appeal is *ad hominem*. If I know that I have an experience, this is a conscious act, a mental process, an awareness. In this work no attempt is made to analyze this experience further, to distinguish the various grades or qualities of experiencing or knowing, or to justify, psychologically or otherwise, the common-sense datum that I can and do have experience. Ordinarily this implies a polarization of myself over against the objects "of which" I am aware, but the usage here adopted carries with it no implication that such a subject-object polarization is a necessary factor in all kinds of awareness. There may be simpler forms of awareness in which "self-consciousness" is not a factor.<sup>1</sup> I do not know. The various attempts to define mind, mental or psychic, in terms of any kinds of process which are known only as "objects" with any sort of awareness left out, do not clarify the question for me at all.

<sup>1</sup> Lotka thinks that this is probable (1925, p. 392).



MacMillan (1925, p. 96) has written: "Energy itself is not defined, but it can be measured, and with that measurement we must remain content, for the thing itself escapes us." To this aphorism we might add another: Mind itself is not defined, but it can be experienced and with that experience we must remain content, for the thing itself escapes us.

If now we assume as a working hypothesis that consciousness or awareness is a function of the body, or a property of particular patterns of matter in motion (for this is what the "functional view" amounts to in the upshot), the objection immediately arises that consciousness is a strictly personal and unique phenomenon so unlike everything else in nature that it cannot be fitted into the natural order at all. To this it may be replied that every other property of matter is similarly unique. Gold is heavy; it is also yellow; and the heaviness and yellowness seem to be disparate phenomena. We accept them as given in experience. Nevertheless, we do not find it expedient to detach the yellowness from the natural order to which gold and its specific gravity belong and establish for color an independent order of being which runs parallel with our natural order of ponderable things. We are not able to explain the relationship between specific gravity and color as fully as we would like, yet we believe on good scientific grounds that both inhere in the same natural order of phenomena.

Similarly, consciousness seems to be a function of certain very special structural arrangements of nerv-

ous tissue and biologically there is no more reason for detaching this function from its organs than for detaching the function of contraction from its organs, the muscles. Each of these functions is unique, but both are evidently fitted into a single natural biological order in lawful fashion.

Now, the unique property of the organs of consciousness is that the mechanism is aware while it is acting. The clear-cut awareness of human experience seems to have emerged from less differentiated vital processes gradually just as other highly specialized functions (such as respiration, flight, and tone analysis) have done in the course of evolution. Of course it is unique, of course it is strictly personal, of course it is not demonstrable by the usual technique of objective physiology, for these are just the characteristics which differentiate awareness from the other bodily functions.

The trouble seems to be, as Professor Landacre has pointed out to me, that in our attacks upon the problems of consciousness we have too often sought to get at the absolute or ultimate nature and essence of mind as a preliminary to an investigation of its practical working and natural relationships. This is a reversal of the ordinary procedure in scientific investigation. Productive research in physics did not begin with the determination or the postulation of the ultimate nature or pure essence of matter and energy, and if we ever reach valid conclusions upon such

questions they will come toward the end, not at the beginning, of our program of scientific study of natural phenomena.

In teaching biology to beginners we do not ordinarily introduce the subject with an adequate definition of life and an exposition of its ontological relationships. In fact, we do not know the ultimate nature of matter, of life, or of mind. But we do know a great deal about these things, and as the breadth of our knowledge increases, the interrelationships of these three domains of knowledge become more evident and the underlying unity of the cosmos in which they inhere becomes an increasingly probable scientific induction.

We can deal scientifically with mind just as we deal with life; it is given as a datum of experience. Our task is to find out as much about it as possible by every available method of study. And as our knowledge increases, the mental phenomena, like the other vital phenomena, are more and more clearly seen to articulate with the rest of nature. Most biologists see no advantage to be derived from the postulation of metaphysical vital forces to help them over the difficult and obscure places in their science, and the argument for the avoidance of such an appeal in psychology is quite as convincing to some of us. And yet the treatment of the mind-and-body problem in most of our current philosophical systems does imply just such an appeal to categories that lie beyond the

reach of scientific treatment of a natural order which is observable and verifiable.

The stories of the battles of the gods as recounted in the ancient mythologies make but feeble appeal to the practical man of affairs today. When, however, it is pointed out to him by some modern seer that these stories are truly symbolic of his own daily struggles, defeats, and victories his quickened imagination arouses and takes notice.

Again, the titanic wars of more recent times between the various philosophic cults leave the earth-bound scientific investigator cold. He is not even an animated spectator. His interests lie elsewhere and he looks the other way. What is it to him that dualists, monists, pluralists, wage their wordy wars over the shibboleths of parallelism, interactionism, epiphenomenalism, and the rest? The weapons of these valiant warriors seem to him but ghostly simulacra, unbreakable because unsubstantial, whose futility has been demonstrated by centuries of quixotic combat.

When, however, the philosopher lays aside his absolutes, his universals, and the other armamentaria of pure reason, sets his feet squarely upon the solid ground of verifiable observation, and essays to do battle with the weapons of science, the man of science is alert. For every scientific worker has a philosophy of nature of his own, either thoughtfully worked out or dimly adumbrated in the realms of prejudice and obscurantism, and he is keen to evaluate the use

which any amateur in the scientific field makes of his own tools.

Interest in the question of the relation of body and mind is perennial and widespread. In its scientific aspects this would seem to lie within the realm of biology, for we know mind scientifically only as related with organisms. Biologists have frequently pointed out proximate solutions of the body-mind question which are regarded as adequate for their purposes, and beyond this they are seldom inclined to go, for science knows no absolutes and no ultimates.

Scientific thinkers themselves are too often content with solutions whose inadequacy is patent even within the contracted field of the practical requirements of some specific scientific inquiry. Perhaps the most common of these inadequate solutions (inadequate, I mean, for the practical needs of science) is the thoroughly unscientific appeal to a philosophic monism which in effect denies the reality of the problem. Two of these monistic cults merit special mention.

1. Pure, or Berkleyan, idealism, which denies the reality of matter, makes small appeal to most scientific men. The technique of their profession and the mental habits engendered by its practice make most students of science practical realists of some sort, and they are disinclined to throw the cherished objects of their researches into the discard as fabrications of their own minds.

2. On the other hand, that brand of naïve materialism which denies in effect the reality of mind or its significance in nature is very popular in some scientific circles. This negation of mind or its contemptuous banishment into the outer darkness as an irrelevant epiphenomenon (which largely through the vicious influence of Haeckel has come in the popular mind to be regarded as the only true monism) also rests on an acknowledged or implicit philosophical basis. It is a thoroughly unscientific procedure, for to any unprejudiced observer mind is a factor in many biological situations which cannot be discarded without removing something which is essential for a full scientific analysis. The true solution of a scientific problem is not facilitated by discarding the troublesome factors of the problem and attending only to those which we know in advance will readily yield the desired answer.

These two favorite expedients of traditional philosophy—"pure" idealism and naïve materialism—must, then, be laid to one side, for they do not satisfy the scientific requirements of a true solution of the body-mind question. To try to solve the problem of the relation between these two things by denying the reality of either is to fly in the face of both science and common sense.

The biologist, I repeat, is not interested in these questions from the philosophic standpoint. He is not concerned with ontological or epistemological prob-

lems as such. But when philosophical conclusions, no matter how these were arrived at, are presented to him as a basis for the prosecution of investigation in his own field (and this not infrequently happens, either by design or unwittingly), he must examine the fitness of these conclusions for his own purposes. If they do not square with the facts as he knows them, he must lay them aside, for the time at least.

The biologist, in adopting the simple and naïve doctrine that consciousness is a function of the body, of course does not claim to have solved the philosophical problems of consciousness; he does not know how the processes which constitute his subjective experience, his awareness, have arisen genetically, nor the method of their connection with the related metabolism. Neither does he know the ultimate nature of muscular contraction or of any other vital function; or what may be the reason why when hydrogen and oxygen are combined in the ratio of 2 to 1 there results a compound called water with properties so apparently incommensurable with those of both of the constituent elements. These are all matters of pattern of combination of simpler units, and it is a reasonable hope of science that the laws of all of these combinations will some day be discovered. In the meantime, our ignorance of the way in which the properties of water are related to those of hydrogen and oxygen and our ignorance of the way in which the manifestations of consciousness are related to

those of metabolism of nervous tissue are of the same order of magnitude—total in each case. We can only accept the data as given and conform our practice to them. The fact that we do not know how the brain functions in consciousness need not blind our eyes to the fact that it does so.<sup>1</sup>

Consciousness, then, as viewed biologically must be considered as a member of the complex of vital modes, and as such it must be considered in causal relationship with other vital processes; in short, it is a causative factor in the same sense that muscular contraction and reflex response are causative factors. One cannot say, if arguing rigorously, that muscular contraction is *the cause* of the movement of my arm, but rather that the muscular contraction is one of the countless factors in the complex processes which eventuate in the movement in question. It is true that in scientific analysis I may abstract the contraction from the other factors and investigate it alone. So consciousness as a biological cause is interwoven with other factors of conduct, from which it can be separated only by a process of scientific analysis or logical abstraction.<sup>2</sup>

<sup>1</sup> Lotka (1925, p. 391) suggests that "the continued conscious state of matter requires constant *excitation* by the metabolic processes, somewhat as the continued maintenance of a magnetic field in the neighborhood of the conductor requires constant excitation by the passage of a current."

<sup>2</sup> Consciousness, psychologically considered, is already abstracted from the other factors of conduct, for its differentiating feature is just



Under no circumstances may consciousness be treated scientifically as a *deus ex machina* which acts upon matter from the outside, but only as one of the modes of behavior of matter in motion. There is no alternative view which can be articulated with the body of scientific laws as now known, nor is there any reason for hypothecating any as yet undiscovered principle of relationship of mind and matter which is not congruous with the rest of our knowledge of nature. The obvious and simple deduction from the well-known facts of daily life, as well as from all that we know of physiological psychology, is adequate for all scientific purposes: mind is a function of the body.

If we are to adopt a functional view of consciousness, it must be with whole-hearted surrender of cherished metaphysical idols without reservation, and the conscious processes must be accepted as real physiological functions which are knit into the vital fabric in just the same way as are other modes of behavior of the living substance.

The biologist reaches this conclusion, I repeat, not by way of metaphysical speculation or traditional philosophical analysis on *a priori* grounds; it is a

---

this awareness, known only introspectively, which comprises the distinctive subject matter of introspective psychology; but one of the major subdivisions of psychology, physiological psychology, is concerned chiefly with the problem of the synthesis of the introspective data with the data of physiology and anatomy, that is, with the redintegration of the biological unity which is dissociated in sophisticated experience as subjective and objective.

matter of direct observation on the biological plane. Human organisms, one of whom I know to be conscious and others of whom I have valid scientific evidence for so regarding, manifest types of behavior not possible except as expressions of conscious processes. They predict eclipses, write poems, invent machines, and dig canals, which profoundly affect the subsequent course of biological and even of inorganic events. And these processes are functions of their bodily organization in the same sense as are their respiration and locomotion, with definitely assignable anatomical organs in each case.

This conception of cortical function is thoroughly mechanistic. Every cortical activity is knit in with other bodily processes in causal sequence. At no point are non-mechanistic or mystical agencies admitted. The cortical functions are exceedingly diversified. Of some of these functions we have as yet no knowledge at all; others are open to objective study by the ordinary physiological methods now at our disposal; and some are characterized by an awareness of some sort while the functional process is in action. The relation between the second and third of these types of function has not yet been clarified. But the scientific evidence is adequate and unambiguous that the introspectively known activities are functions of the brain that articulate in causal sequence with other bodily processes. They are not parallel phenomena, by-products, or any other sort of pseudophenomena, and

they are no more "non-physical entities" than are any other bodily functions.

If mind is a function of body, as most biologists seem to believe, then surely the recognition of mental phenomena is not mysticism, nor is there any justification for ignoring these functions in a scientific analysis of human behavior. Until we know more about the relations of mental and physiological phenomena it would seem to be sound scientific method as well as sound common sense to observe the mental phenomena by the one method which at present gives us fairly trustworthy (though admittedly incomplete) information about them, namely, introspective experience.

## CHAPTER XVII

### VITAL RESERVES

*The human individual lives usually far within his limits; he possesses powers of various sorts which he habitually fails to use. He energizes below his maximum, and he behaves below his optimum.*

—WILLIAM JAMES

**V**ITAL processes in general involve the accumulation of certain reserves of material and energy whose expenditure may on occasion improve the efficiency of action. Reaction is not merely transfer of energy applied at the receptor surface and released at the effector organ like the working of a lever. The living body is constantly accumulating a reservoir of potential. A slight stimulus may tap this reservoir and be followed by a torrential expenditure of energy quite out of proportion to the pull that opens the valve (Herrick, 1924, chap. xix).

The mechanisms of “trigger action” of this sort are amplified and enormously complicated in the nervous systems of higher animals. The cerebellum appears to be fundamentally such a storehouse of nervous reserve which is drawn upon automatically during the progress of all muscular activity.

These reserves are not necessarily static, mere potential energy of position. They may be as dynamic

as the stabilizing action of a gyroscope. Facilitation through habit may result from a permanent change in the structure of the nervous circuits. Or it may be an expression of an enduring change in the dynamic pattern of constantly recurring nervous discharges such as to draw off into particular efferent pathways some reserve nervous energy formerly unavailable. The reserves here drawn upon are generalized non-specific energies whose actual expression is determined in each case by the nature of the going concern into whose activity they are incorporated.

Even the simplest reflexes that are actually performed by the living body involve the expenditure of some accumulated reserves whose sources are knit in with the reflex circuits. This gives to these "natural" reactions their impulsive drive. The appropriate reaction goes off "of itself" when the adequate stimulus is applied because the body is made that way. This free discharge of energy is satisfying if the appropriate end is attained, if in biological terms the reaction is adaptive. Otherwise the reaction continues unchecked, and fresh reserves are drawn upon.

In an unusual situation for which no appropriate reflex circuit is already structurally in readiness the internal reserves are repeatedly tapped in successive trial-and-error reactions until an adaptive response is achieved or fatigue puts an end to the process. These trials may eventuate in overt action or they may take the form of "implicit" reactions, trials whose pro-

cesses are all confined to the cerebral cortex. In both cases a large amount of reserve energy is expended.

This is the physiological basis of so-called spontaneity and of impulse, the inner urge to action which goes on with or without consciousness as a natural expression of the structural organization

The vital reserves of which we are here speaking are by no means exclusively nervous functions. They are common to all living organization. Each part of the body has its own reserves which come to expression in local tone and spontaneity. And these local expressions may in turn influence the general behavior in very significant ways, as has been brought out in numerous studies of the normal spontaneous activity of the rat and the relations of the total amount of spontaneous activity to physiological rhythms of the gonads, hunger contractions of the stomach, etc. (Slonaker, 1912, 1924, 1925; Richter, 1922; Wang, 1923; Wang, Richter, and Guttmacher, 1925). Here, also, should be mentioned the numerous studies of the relation of behavior patterns to the maturation of the related bodily organs, such as those of Stone (1922, 1924).

Tracy (1926), in a careful study of the development of the behavior patterns of the toadfish, has observed the independent appearance of spontaneous movements of a rather complex sort in different parts of the body. It is at a distinctly later stage that these local activities are knit together into a co-ordinated

behavior pattern. And this local activation or reinforcement is never lost or diminished, though in adult life its character may be greatly changed and it may come under the influence of other regions of more powerful and effective control.

Tracy has shown that in these fish the first movements are strictly local endogenous or "spontaneous" activities of the separate parts of the body. These parts are successively connected by developing nervous pathways with resulting integration of the dispersed activities into unified reflex patterns. This is well advanced before the larva is capable of making any response whatever to external stimulation. As development proceeds, the exteroceptive reactions are built upon the foundation already laid down in the endogenous behavior patterns. The externally excited or exogenous nervous impulses "capture" and bridle the more primitive endogenous motor systems, which

form a continuous ontogenetic series with the voluntary movements of the adult. . . . It is suggested that voluntary movements are the result of the organismic integration of the endogenous activity of the various mechanisms (visceral and associational) of which the organism is composed through the establishment of an excitation gradient in the central nervous system which enables impulses from some one mechanism to obtain temporary possession of the final common path to the exclusion of all others.

Cortical evolution seems to be the culminating phase of the process here sketched, whose earliest

stages have been so minutely recorded by Tracy. The tonic influences of the cortex seem to be well advanced in differentiation before its phasic activities have passed beyond rudimentary form (p. 213). With further elaboration of the association centers as apparatus of intentional control, the phasic activities of the cortex "capture" and bridle the tonic influences, and voluntary activity now directs the course of conduct which hitherto was under much more immediate control of the exteroceptors.

Trigger actions of the sort implied in immediate response to stimulation, however complicated, are of rather primitive physiological type. Opposed to them is another kind of accumulation and expenditure of reserves that is especially characteristic of the human cerebral cortex. I refer to the preservation of some sort of record of specific reaction patterns or experiences which can on occasion be reactivated in the original form.

This, again, is a common protoplasmic function in its elementary form. Even in higher animals habit formation through repetition and learning by trial-and-error do not seem to be essentially cortical types of activity. But the retention of the effects of an individual experience in such form that the reacting mechanism can later be reactivated with recall of the experience and the interweaving of this recalled experience into a present reaction pattern, that is, the influence upon present conduct of memories of partic-



ular past experiences—this does seem to be in mankind a typically cortical sort of nervous action.

On this view of the mechanics of cortical function we see that to the non-specific cortical reserves of the rat there are added immensely more significant reserves in the human association centers. These reserves are manifested in several forms.

First, every mnemonic vestige, every engram, is represented by a complex web of interrelated neurons, each with a certain potential energy while in the resting condition. When reactivated in recall (say by a sensory stimulus) the reserve energy of this mnemonic complex is released and is available both to co-operate with the reactivating sensory excitation in determining the nature of the response and also to intensify that response and inhibit or neutralize all other responses. Obviously, in these specific memory vestiges or engrams we have a sort of cortical reserves quite different from the non-specific reserves of the cerebellum and other more primitive nervous apparatus.

In the second place, the cortex contains innumerable nervous elements with short axons (type II neurons, see p. 91) which seem structurally not well adapted to participate in the more extensive associational patterns of the usual memory vestiges but are so situated as to be able to function in a non-specific way by discharging their reserve energy locally into any associational system that at the moment may be

activated within their field. Each of these may be activated by any one of the numerous associational neuron systems which traverse its vicinity. These non-specific reserves may be utilized successively by many different associational systems and perhaps play a large part in maintaining cortical tone and supplying the energy or driving force so characteristic of some higher cortical functions.

Thus we have in the cerebral cortex (as elsewhere in the brain) abundant provision of non-specific neurological reserves available on demand for any cortical activity, and in addition an accumulation of an enormous number of specific mnemonic reserves, each of which is a particular pattern of associational neurons of very complex organization. The preservation of these structural alterations (engrams) each of which has resulted from some particular personal experience, and the power to reactivate these structural associational patterns in appropriate new situations with reinforcement from the intrinsic non-specific type II cortical neurons, give to the human cerebral cortex its unique position as the master-tissue of the body.

Spontaneity, initiative, inventiveness, and what we call "dynamic personality" are physiologically very expensive functions. The immediate source of their energies is largely cortical, and the known structure of the cortex indicates that ample reserves are available on demand for reinforcement of any cortical pattern of associational activity whatever.

In times of stress a man will outlast a horse, and an educated man may outwork an uncultured man of much more powerful physique because the cortical reserves are available to drive jaded muscles on to intense effort long after fatigue has exhausted the normal capacities of the subcortical apparatus. A part of this superiority lies in the intelligent conservation of effort in the earlier stages of a long program of severe labor and other expressions of the reserves of associational patterns to which reference was made above. But a part of this superior efficiency apparently results from direct activation by the cortex, which acts like a spur to an exhausted horse.

There is abundant evidence (for the most part indirect) that the primary innate or "natural" modes of behavior are physiologically less exhausting than are activities involving recombination in unaccustomed patterns and reintegration of these more primitive modes of behavior. As I have elsewhere written (1924, p. 272):

Reflex and instinctive action are biologically inexpensive. Their patterns are fixed and the apparatus is, as it were, manufactured wholesale and distributed by heredity to all members of the species. Individual conscious adjustment is much more costly; in fact, it is the most precious thing on our planet.

The price which must be paid for this sort of creative living fortunately does not have to be drawn from today's income; there is a large balance in reserve subject to sight draft. The income of energy

and material which has been accumulated throughout the entire preceding course of life, in short, the totality of our experience, can be drawn upon and made immediately available on demand. It is the whole personality that reacts to meet every situation (Carr, 1925, p. 343).

The biological reserves which are thus expended may be considered from two standpoints: first, the energetics of the process; and, second, the patterns in which the energies are released. The end-results of the second factor can in some cases be observed directly in the study of overt behavior. The investigation of the energy transformations involved is a much more recondite matter.

All living substance in the resting condition has some unexpended potential energy. In the nervous system there is much accumulation of this sort, laid down in a characteristic iron-containing nucleoprotein which is chemically unstable, the chromophilic substance, or "Nissl bodies." The oxidation of this intracellular material may liberate energy rapidly where it will do the most good (Herrick, 1924, pp. 108, 256).

The amount of blood supplied to various parts of the body is roughly proportional to the rates of metabolism or chemical change characteristic of those parts. The number of blood vessels or the density of the capillary network in various parts of the brain can, therefore, be taken as an approximate quantita-

tive index of the relative metabolism of these parts. Craigie (1920, 1921, 1925), in a series of observations on the vascularity of the brain of the rat, brings to light some very interesting facts.

The primary sensory centers, like those illustrated in Figure 1 (p. 39), are more richly vascularized than are the motor centers. This is correlated with the fact that in the sensory centers there is a considerable amount of correlation, a physiologically expensive "legislative" function, while the motor centers are concerned with the physiologically simple "administrative" processes (Herrick, 1924, pp. 245, 257).

In the cerebral cortex of the rat Craigie has investigated the relative vascularity of five regions—parietal, occipital, temporal, precentral, insular—whose vascular richness diminishes in the order given. The charts accompanying his paper (1921, Fig. 1) show that the somesthetic-motor region has the richest blood supply and the insular cortex the poorest. The areas examined in the occipital and temporal regions lie at the margins of the visual and auditory fields, respectively. In view of the theory of the organization of the associational cortex of the rat already presented (p. 251 and Fig. 51), it would be interesting to learn how the vascularity of these two marginal areas compares with that of the central points of the visual and auditory projection fields.

In the developing cortex, capillary richness is directly related with the rise of functional activity, and

the latter requires a greater blood supply than does growth. The granular and supragranular cortex (layers I-IV of Brodmann, see p. 88) are more richly vascularized than is the infragranular cortex, a point of interest in view of Bolton's (1914) view that the higher cortical functions are served chiefly by the supragranular layers.

We have no data on the vascularity of the human cerebral cortex which can be compared with Craigie's observations on the rat. From the evidence at hand it seems probable that the amount of vital energy expended is greater in the case of complex associations than in smoothly running reflexes and automatisms. And this energy is derived from consumption of tissue in the case of brain work just as truly as in the case of muscular work.

Human effort, then, may take two forms. The first is the performance of physiological work with expenditure of much energy and the drawing off of non-specific bodily reserves (of peripheral and cerebellar type), all by virtue of a surpassingly complex and efficient internal organization which is stabilized and stereotyped so that it operates efficiently and either uniformly (as in reflex) or by trial-and-error selection of the adaptive response from among a limited repertoire of available reflex patterns. There is no occasion for consciousness in this form of activity; there is effort but no volition.

The second form of effort is best seen in that be-

havior which in mankind is controlled from the cerebral cortex where the end sought is consciously formulated and the course of action is shaped in part in terms of past personal experience and in part by impulsive and emotional drives whose energies come in some measure from visceral and other reactions linked with the process as it advances. This is voluntary effort (Carr, 1925).<sup>1</sup> The intellectual component of this process is purpose; the affective component is desire or wish.

It need not be repeated, I trust, that none of these centrally motivated processes are to be regarded as spontaneous in the sense of being uncaused action, nor are their manifestations capricious or lawless. The causes of the release of the various sorts of latent reserves here under consideration may be diverse. Ordinarily, it is some sensory activation from lower centers which releases the trigger of a cortical pattern of neuronc discharge. In other cases it may be a product of endocrine activity, oxygen-hunger, or some other peculiarity of the composition of the blood stream which acts directly upon cortical tissue,

<sup>1</sup> Cf. Lotka (1925, p. 421): "With regard to the present and past the Self is a *Knower*. With regard to the future he is a *Willer*, that is to say, he has *direct* cognizance of certain past and present events through sensation and memory; he has *direct* cognizance of certain future events through his will. . . . ."

This consciousness of causes within us of certain future (external) states is just what we *call* will. Will is our subjective realization of what to an objective observer would appear as (physical) causes of the events 'willed.'"

although of such influences we have only very meager evidence.

The energies of the cortical reserves, however released, tend to come to expression in orderly patterns depending on the structural organization at the moment of their discharge. So far as these reserves are non-specific or tonic, the patterns of their manifestation will be determined chiefly by the nature of the subcortical process into which they flow. So far as they are phasic, they are expressions of the activity of certain cortical neurons with a specific structural configuration or "set." And since these cortical configurations are largely results of individual or personal experience, these energies may properly be regarded as expressions of the personality of the individual.

The plasticity of cortical organization (in contrast with the rigidity of the reflex systems) gives to the cortex its efficiency as the arbiter or "decider" of conduct. For a given cortical configuration or "set" of specific neuronic systems may be reactivated in numberless different situations. I may use my "memory" of Bright Angel Point at the Grand Canyon to draw a map for the guidance of another tourist, as the inspiration of a poem or some other artistic creation, as an illustration of a neurologic process, or as a motive for revisiting the scene at some future time.

The internally determined efforts and volitions are no more myths or figments of unfettered imagination than are the simpler impulses of an insect's



phototropism; they are real biological functions. It is popular nowadays to fix attention on those factors in the control of behavior which are imposed on us from outside our own personalities—the hereditary patterns given at birth, pressure of environment, etc. These, too, are real, but they are not the most vital realities in the “continent art of living well.”

The practical problems of making the most and the best of our lives center around the play of those intimate forces that well up inside of us and determine how we are to react to the world in which we must live. Impulse is a crude form of internal control of behavior, very efficient and quite adequate for most of the behavior patterns of lower animals and for the more primitive types of human adjustment. But in a social environment it is inadequate; it breaks down and must be supplemented by rationally appraised purposes and desires and by consciously fabricated ideals.

These last are just as truly parts of the biological machinery of living on the human plane as are heredity, environment, and physiological impulse. Intelligently directed effort, reinforced by vividly conscious emotional thrills, wishes, hopes, and aspirations, are pre-eminently human functions of specifically human forms of bodily organization, of which the most distinctive members are in the cerebral cortex.

Impulse in its elementary biological form is, then,

an expression of the internal reserves of the organism; it is one of the primary expressions of the process of living. Like all other vital processes, it is one of the modes of reaction of a special protoplasmic organization to the environmental agencies with which it is in energetic correspondence, though the connection with the environmental energies is less direct than is the case of that aspect of the simple reflex which is immediate response to stimulation. Its efflorescence in human behavior we call "purpose" and "voluntary effort." These are so important components of man's action system as to justify more detailed examination. The chapter which follows is taken (with slight modification), by kind permission of the editor, from an article in the *Psychological Review* (1925*b*) entitled, "The Natural History of Purpose."

CHAPTER XVIII  
THE SOURCES AND ENDS OF  
HUMAN EFFORT

*Mind is not the introduction of teleology into a non-teleological world, but a special instance of natural teleology.*

—F. J. E. WOODBRIDGE

*Intelligence is incarnate in overt action, using things as means to affect other things.*

—JOHN DEWEY

SOME of the current discussions of purpose seem to shoot wide of the mark, or else perhaps they are shooting at very different targets. An approach to the subject from the biological side by a biologist may help to clear the air and improve the aim. Does a rat show purpose in running a maze? This may be largely a matter of definition of words. The term is commonly applied to certain human activities where the end toward which the act is directed is consciously recognized. Let us start with these human purposes.

The human type of consciousness (which is the only kind that I know anything about at first hand) exhibits, among others, two characteristic features: first, human thinking is symbolic; and, second, the generalizations expressed by language and other symbols may be so enlarged as to connote more extensive uniformities of experience (laws of nature) which can

be projected into the future, thus permitting prediction of future events, adjustment of present behavior with reference to future contingencies, and the fabrication of conscious purposes.

Hunter (1924) has analyzed the mechanism of the symbolic process, and his analysis in objective terms is all to the good. To be sure, his neurologic schema is purely hypothetical, but it is as good as any other hypothesis and it is helpful in impressing upon us the very elusive fact that every mental act is the function of some special anatomical configuration of parts.<sup>1</sup>

In the neurologic diagram presented by Hunter, a considerable part of the schema is necessarily hypothetical because we do not know all of the connections of the parts which are activated when we say the word "box" upon seeing this object. But a similar schema designed to illustrate the connections of parts activated when my biceps muscle contracts reflexly in response to a pin prick would likewise have to be filled in by wide stretches of hypothetical construction. We do not know exactly how a sense organ is excited, how a nerve fiber conducts, how a muscle contracts, how a gland secretes, or how the brain thinks, though we have satisfactory evidence that all of these organs do perform the functions mentioned. No biologist with all of the evidence before him can fail to make this deduction. Why some other people accept the

<sup>1</sup> For other schemata of these cortical processes, see Bianchi (1922, pp. 245-251) and Cole (1925).

evidence on all of these cases except the last and refuse to do so in that one is hard to understand. Presumably it is due to lack of knowledge of the biological evidence<sup>1</sup> or else to a mind fortified against this evidence by prejudice. Such a prejudice may arise from a habit of mysticism, from some incompatible *a priori* philosophical postulate such as parallelism, or perhaps from a phobia against mysticism so powerful as to shy at a shadow cast by a past mysticism on very real experience.

Whether consciousness is present in any particular neurologic process is a fact that can be determined directly in the experience of the subject, and its presence or absence is independent of our knowledge of the working of the mechanism. When it is present it is the part of science as well as of common sense to accept it as given—as a datum of experience—in just the same way that we accept sugar tolerance as dependent upon the normal working of the pancreas, though in neither case have we an adequate understanding of the mechanism actually employed. For this we live in hope.

Symbolism, accordingly, can be treated scientifically either (1) in terms of its mechanism, which in the present state of our knowledge must remain largely theoretic, or (2) in terms of the awareness of the

<sup>1</sup> Current psychological literature is crammed with illustrations of this ignorance where confusion has taken the place both of mysticism and of established fact, some of which are commented upon in Warren's *Neurology: mystical and magical*, *Psychol. Bull.*, vol. 20 (1923), pp. 438-443.

symbolic process, where the evidence is direct experience, though the experiencing process is so unique and so refractory to analysis that we have great difficulty in articulating it with other natural processes.

The second characteristic of human consciousness to which reference was made above, namely, the forecast of future events and shaping of present conduct in reference to future contingencies, uses symbolism as its necessary tool. It comes to fruition as conscious purpose. And here again it is easier and more satisfying (in the present state of our knowledge of the nervous system) to experience purpose than to unfold its bodily mechanism.

Symbolism and purpose as natural functions of the human body doubtless have natural origins. There is no evidence that they have always existed in the forms experienced by us or that they exist at all in the newborn child or the lower mammals. But, of course, they are not made out of nothing.

The origin of symbolism may well be conceived along the lines suggested by Hunter. Or, to express it neurologically, the associational fields of the cerebral cortex seem to provide the anatomical mechanism of the process, a mechanism that more than doubles in mass and in internal complexity as we pass from the highest anthropoids to man. The biological origins of purpose can be sought with fair prospect of success in certain very general features of all animal behavior, and to these we will next direct attention.

It is generally recognized that many animal reactions, such as the typical tropism, reflex, or instinct, have both a backward and a forward reference. The forward reference we express biologically by saying that these activities are in general adaptive, that is, the animal tends to react in each frequently recurring situation in fixed modes that favor the preservation of the individual or the species. This teleological behavior is not directed by any awareness of the ends to be attained, but the organization has been so shaped by its past history (the backward reference) that it can do no other.

This backward reference involves no mystic forces. In evolutionary history and personal development the structure of the body has been shaped by biological processes (some of which are well known) in adjustment with the world in which it lives. The vital process is at basis just this adjustment, and the structure of the body at any moment has been determined by the history of previous racial and individual adjustments. And this structure, in its turn, determines the action system of the individual at that moment.

The action system of the individual is, accordingly, the dynamic expression of his inner nature, and both of these have been biologically determined. The inner nature (that is, the protoplasmic organization) being what it is, the behavior is largely predetermined by the existing structure, and reactions to stimulation tend to follow the established patterns—tropism,

reflex, instinct—which in general are good for the organism exhibiting them. It is easy, therefore, to see why these tendencies are the strongest kind of internally determined impulsions. The impulse, not being intelligently directed, persists even when in a particular case it may be harmful, as seen when the moth repeatedly sears its wings in the flame.

These impulsions are coeval with life, and they have persisted throughout the entire course of organic evolution. They face backward in that they have been shaped by biological agencies, such as natural selection during the previous evolutionary history of the species, or by habit during the individual life. They face forward in that they are adaptive or directed (in general) toward some useful end, to wit, the welfare of the individual or the species.

Reflex behavior in any particular instance is, accordingly, the result of some adequate stimulus acting upon an internal organization which has been so fabricated during its own past history as to predetermine the nature of the ensuing reaction. The stable pattern of the internal structure at the moment is, therefore, a causative factor in determining the dynamic pattern of the behavior. It is not a mystic "force" (Warren, 1923).

This primitive sort of impulse is an expression of a definite trend or "set" of behavior patterns in modes which have been established and stabilized in previous racial and individual experience and which,



while in actual operation, may draw upon certain biological reserves (present in every organism) and so exhibit a characteristic physiological pressure or "drive."

If we apply the expression "a push from behind" to these hereditary and habitual impulses, we use figurative language. Neither heredity nor habit is a force, but these are expressions of fixed structural molds through which certain of the vital energies must come to expression (if at all) and by which the character of this expression is determined.

Josey (1922) has, in fact, fallen into a grievous fallacy here. In attacking certain appeals to mystical forces as determiners of human behavior (which still persist in some quarters) he goes too far and in effect denies the practical significance of any innate factors in behavior. These innate factors are not extraneous "forces" or metaphysical agents; they are stable patterns of protoplasmic activity, and as such, they are true causative factors in behavior.

The driving power of impulse is derived not at all from mythical hereditary "forces" and in very small measure from the physical energy of the stimulus which sets off the impulsive process. The internal sources of this impulsive energy are of two sorts. First, there are the general bodily reserves of energy in excess of immediate needs normally present in every healthy organism, to which in higher animals there are added elaborate devices for step-up of en-

ergy within the central nervous system, as in the "avalanche conduction" of the cerebellum (Herrick, 1924, pp. 263 ff.). These are knit in with the stereotyped action systems and supply the impulsive energy or "drive" of all reflex and instinctive behavior.

The second kind of apparatus of neural reserves is well developed only in the higher vertebrates and pre-eminently in the association centers of the human cerebral cortex. It is radically different from the other. The first sorts of reserves support reaction patterns which, in their broad outlines certainly, and apparently often in detail, are laid down within the innate organization and are with difficulty modified (in lower animals) by personal experience. Here the associated reserves in general reinforce, prolong, or otherwise facilitate the reflex and instinctive behavior. The second sorts of reserve mechanisms, on the other hand, are superposed upon the innate apparatus (not knit into it); they mature much later (wholly postnatal in the human infant), and the patterns of their development are largely shaped by individual experience. They are functionally knit in with individually modifiable behavior.

Reflex and instinctive action function largely in terms of racial experience. The association centers, on the other hand, form in the aggregate the great storehouse of personal memories, the residua of individual experience. These centers contain countless nerve cells with short axons (type II neurons) whose

connections are such as to permit their activation in relation with each one of numerous different associational patterns, thus making possible a great influx of nervous energy in addition to that of the neurons which form the essential links in the particular associational chain at the moment active.

These cortical reserves are drawn upon, not like those of the lower brain centers to reinforce the administrative machinery of structurally predetermined reactions, but to co-operate in determining on the basis of personal as well as racial experience what act is appropriate to the present situation. This is a distinction of far-reaching importance. It is the presence of the cortical reserves, partly unformed and mobile and partly laid down as definite mnemonic patterns or engrams, that make constructive thinking possible, a process in which residua of former experience are reassembled in new patterns.

Now, colligated with the amplification of the cortical apparatus for registering and reactivating the mnemonic and other reserves of the human associational fields, we observe the elaboration of symbolic thinking and the emergence of new capacities to formulate uniformities of experience, to project these uniformities into the future, and so to predict coming events.

This forward projiciency of experience is not a new and mystical "force" added from the outside to our biological impulses to transform them into volun-

taristic purposes. On the contrary, since all mental acts are functions of the nervous system, human purpose and choice in view of probable future contingencies are simply functions of a different sort of nervous system from that tiny speck of nervous matter which sets the direction of the insect's reflexes.

The forward reference of reflex and instinctive behavior, its biological adaptiveness, is not in lower animals so far as we know accompanied by any "mentalistic something" that in our own experience we identify as purpose. If we choose to give the name purpose to any "toward-whichness" of behavior, as Tolman (1924) does, this is a matter of definition of terms which need not here be debated. We agree that this type of animal behavior which persists until some definite result is attained can be described adequately for present scientific uses without any mentalistic complications. But the purpose of which I am speaking here is that sort of human behavior which is consciously directed toward an end that is more or less clearly formulated in mental terms. And I maintain that when this awareness of ends to be sought is present and is a component factor in a causal sequence of action it is not a negligible element in a behavioristic account. And that it is present in some of my own choices, I have direct evidence as a datum of experience.

This power of conscious choice in the light of prob-

able future contingencies, again, has not grown up out of nothing. It is an amplification of the "forward reference" of those reflex and instinctive reactions already considered. The "end" which in the reflex is attained blindly is here purposefully striven for. Even in the simplest verbal symbolism the internal apparatus of this forward reference is far more elaborate (especially in its social implications) than in the most complex instinctive or "native" behavior, as Dewey (1922) and Mead (1925, p. 271) have shown. The significance of this in behavior has been overlooked in Hunter's oversimplified schemata.

My judgment of the probable course of future events and my forecast of the probable consequences of my own proposed action are determining factors in shaping a decision or "making up my mind" to a purposeful choice just as truly as are my hereditary predispositions, my established habits, and my temporary physiological condition of hunger, fatigue, depression, or exuberance of vital tone—and they may be by far the most significant factors.

Every cortical process is a natural result of previous bodily activities. It is, in turn, a cause of subsequent bodily activities. This cortical process may or may not be a conscious act. Its antecedent causes may be previous mental processes or events of simpler physiological sorts; its results may be mental acts, muscular movements, and events in the surrounding physical world. If the cortical process is a mental act,

this is a fact, a datum of experience, the neglect of which leaves the causal sequence incomplete.

Let us suppose that I am debating whether to spend the ten dollars that I have just received as a birthday present upon a dinner with my wife at a fashionable restaurant or upon a book that we have long wanted to read together. I set over against a gay evening amid the bright lights the prospect of many quiet evenings at home with a favorite author and I cannot make the decision until I recall that I am at present convalescent from an illness. The prospect of a gastric upset following injudicious eating decides the matter and I determine to buy the book.

Every step in the process of making this decision and forming this purpose is causally determined, and the choice actually adopted is the mechanistic expression of the working of my internal organization at the moment of its exercise. The factors which have operated in the fabrication of this inner nature whose expression is the purpose are various in the extreme—hereditary disposition, habit, countless memories, etc., all facing backward, and in addition to these the rational analysis and evaluation of the probable future consequences of each of the two lines of conduct under consideration. This mental act, whose neurologic mechanism I can picture in only the vaguest outlines, is unquestionably the dominant factor in the causal complex. Why not recognize it in its own right for what it is and put it in its proper

place in the causal sequence? And clearly the fact that it is *my* stomach that will ache if I overeat and the emotional pulse that wells up in my consciousness at the anticipation of such a result can be evaluated and treated scientifically as truly—though not as completely—as if I knew all of the neurologic and endocrine activities that condition this emotional pulse.

And this “vital, personal quality of experience” which Lashley (1923) would throw out of science into art or mysticism is a real datum of experience which is not esoteric or mystic unless we choose to make it so. The demand that we evaluate scientifically subjective experience by exactly the same criteria as are adequate in physics and chemistry is a thoroughly unscientific procedure, for the differentia of mind as I experience it is just this “personal quality” that is (for me) absent in those natural processes that I objectify. Some differentiating features are characteristic of every field of experience that we recognize in our classification of the sciences—biology, astronomy, chemistry, etc. We do not insist that the data experienced in these fields shall be identical, but we do insist that they shall be congruous and that they knit together in a unitary system of nature. And my mind does knit in with the rest of my living in just this way.

The various departments of experience (the “sciences”) are differentiated partly in terms of the kinds

of things that evoke the experience, partly in terms of the technique employed in enlarging this experience, and partly in terms of the interest or attitude of the experiencing subject. To conform to our present canons of scientific validity, all of these experiences must cohere in a unitary system of cause-and-effect sequences. This way of looking at the cosmos has grown up within scientific experience. It is a scientific, not a philosophic, dogma. In fact, in many circles it is in disrepute, on philosophic, religious, or sentimental grounds, not on scientific grounds.

There are three fields in which this scientific dogma presents especial difficulties—life and death, mind and matter, and the current doctrines of relativity—and mysticism has been invoked in each of these fields without advancing our understanding of them in the slightest degree. The whole trend of science is in the direction of integration of experience, and in the light of history there is nothing to be gained at present by throwing overboard the scientific method. This method demands that we endeavor to fill existing gaps in experience rather than adopt easier short cuts to a solution through pluralism, a solution which in the end resolves itself into a name for our ignorance.

That the experience which I do not objectify is causally knit in with that experience which I do objectify and call “natural phenomena” I regard as scientifically established by the same kind of evidence



as is ordinarily applied to other bodily functions. That this subjective experience which I call "thinking and feeling" is congruous with the rest of nature is not so evident, and this indeed has been the great stumbling block in the entire history of the body-mind problem. But there are numberless other instances in natural science where the lack of apparent congruity of phenomena is equally patent, though not so disturbing. Indeed, we have only vague hints of the underlying reasons why the chemical elements exhibit their respective peculiar properties of color, chemical affinity, melting point, etc.; yet we do not doubt that they form a natural system. The fact that this field is being rapidly clarified heartens us, though it is a far cry to a successful outcome when we essay to knit either life or mind into this same unitary system. Vitalism and spiritism do not offer the most promising approach to the problem. In this we agree with the most thoroughgoing behaviorists. Of course, this way of looking at life does not solve out of hand all of the philosophical problems suggested by living. But fortunately we do not have to await these solutions in order to live happily and well, nor indeed in order to develop a very serviceable science of the vital processes.

Wheeler (1923) has endeavored to show that objective behavior and introspective experience are not as disparate as is commonly assumed. "Introspection does not differ in kind from other methods of scientific

observation." . . . "Introspection is as behavioristic a procedure as is watching a rat in a maze." On the other hand, Lashley has reviewed critically the literature of introspection and, out of the mouths of the introspectionists themselves, he has assembled an astonishing array of evidence of the futility of these historic attempts to analyze and explain conscious experience. We admit that the phenomena of gravitation are natural processes, though we have not yet succeeded in analyzing them further and the explanations which have been offered are as fantastic as are the explanations of mind.

McDougall (1923) says that it is roughly true that all the psychologists who continue to make use of introspection while accepting the mechanistic psychology hold to the belief that our thinking or consciousness is the epiphenomenon of the mechanical processes of the brain. Possibly a statistical survey would not bear this out; but at any rate the scientific status of the group of psychologists to whom he refers is not unlike that of some hypothetical cult of physicists who accept all of the properties of matter except gravitation but hold that this is an epiphenomenon of no causal significance and hence negligible in physical science though it may be treated in a separate gravitational science in a non-physical realm.

No abyss of ignorance of what consciousness really is, no futilities of introspective analysis, no dialectic, destroy the simple datum that I have conscious ex-

perience and that this experience is a controlling factor in my behavior.

Lashley in the work cited (p. 272) has endeavored to show "that as complete an account of the attributes of consciousness can be given in behavioristic terms as can be given in subjective terms as a result of introspective study. . . . The statement, 'I am conscious,' does not mean anything more than the statement that 'such and such physiological processes are going on within me.'" He here attempts an impossible enterprise. Even if our account of the physiological processes were perfect and complete objectively, the subjective experience remains a real fact of natural history, not an epiphenomenon or a by-product. There are no by-products in nature. Whether a given product is of value in a particular context is another question. And there are many contexts where consciousness does matter.

When Lashley says in a later passage (p. 336), "The reactions are awareness," he appears to be stating exactly my own position and that of Professor Warren and other advocates of functional and double-aspect theories. But the appearance is quickly destroyed when he adds, "The complexes of reaction meet the subjective description of the organization of consciousness, and leave over no undescribed psychic elements." If any possible account of objective behavior does "meet the subjective description" of consciousness, then the description of that consciousness

is surely faulty. And by "reactions" he perhaps does not mean exactly what either Professor Warren or I would mean by that word in this context.

If our knowledge of physiology were more complete, doubtless we could write energy equations for this entire sequence of events. But energy equations do not tell all that we want to know about any series of natural processes. There are time factors and other matters of pattern of performance that may be very significant.<sup>1</sup>

We know very little actually about the neurologic aspects of symbolic thinking and choice, but we do know that we think and choose and that these acts are causative agents in determining conduct. With us a course of action may be determined impulsively and unwittingly (as in insects), or it may be determined by the same factors which were operative in the insects plus intelligent analysis of the present situation and of the possible future consequences of each of several different reactions to the situation. The prevision of possible future consequences of action is a

<sup>1</sup> This subject has been discussed by Lotka (1925, p. 409): "A quantity which does not appear in the working equation describing the laws of action of a physical system may nevertheless play a significant rôle in the world's events. . . . The equations of dynamics, however perfectly they may picture the course of certain physical events, may fail entirely to reveal or to give expression to an underlying agency that may, in fact, be of fundamental significance. The interference of consciousness in mechanics may be very real, and yet the course of events may *appear* fully determined by the laws of dynamics."

real causative factor in determining which course of action will actually be chosen. There is no uncaused action in either case, no mystic "non-physical forces." And we really are in a position to know more about the causative factors in the second case than in the first. Our present neurologic knowledge is inadequate to present a complete objective statement of the causative factors in both reflex and deliberative purpose, but in the second case our direct introspective experience can fill some of the gaps. The ideas which have influenced the purpose can be called back and re-evaluated, if we so desire.

It is a travesty of scientific method to leave out of consideration in a total view of human behavior just those characteristics which differentiate man from brutes and upon which the further progress of civilization must depend because we do not like to use the only satisfactory data now available for the study of these characteristics.

This argument is shot through with theoretic interpretations of scraps of factual data, some objective, some subjective. I have not hesitated to pass freely from one to the other of these fields in my argument because I am actually doing so in the course of the routine of my daily living. Doubtless I shall be accused of leading a double life. The charge is true. The question is, Does this duplicity rest on a natural or a mythological basis?

Dewey refers to the impossible attempt to live in

two unrelated worlds at once, and if my physiologic life and my psychic life are really as unrelated as many people seem to think, then my case is sad indeed, far more so than that of the psychologists whom Lashley chides for "still precariously bestriding both steeds." Riding two horses at once is a practicable enterprise, though requiring great skill on the part of both rider and steeds. But as for living in two unrelated worlds, even a very slight disturbance of the normal balance between my simpler physiologic functions and those which are conscious may give rise to insane delusions and the disruption of the personality. Sanity of both body and mind is this balance.

Lashley's figure of the circus rider is bad. I am not driving the double team. I am the team. Indeed, you may say, if you like, that I am a whole drove of horses (or functions)—various physiologic processes, simple unanalyzed awarenesses of various sorts, awareness of my body as acting, and awareness of myself as experiencing. The numerous attempts to define these processes more precisely have not, so far, been very successful. But the statement of their reality is not mysticism. It is fact. I am a protoplasmic organization observable by others as well as by myself objectively, and I also am an awareness which is strictly personal and cannot be shared with another except by an indirection, and that very inadequately.

## CHAPTER XIX

### RATS AND MEN

*But, Mousie, thou art no thy lane  
In proving foresight may be vain:  
The best laid schemes o' mice an' men  
Gang aft a-gley,  
An' lea'e us naught but grief an' pain  
For promis'd joy.*

*Still thou art blest, compar'd wi' me!  
The present only toucheth thee:  
But, och! I backward cast my ee  
On prospects drear!  
An' forward, tho' I canna see,  
I guess an' fear.*

—ROBERT BURNS

*Men at some time are masters of their fates;  
The fault, dear Brutus, is not in our stars,  
But in ourselves, that we are underlings.*

—SHAKESPEARE, *Julius Caesar*

**R**ATS are not men. The implications of this thesis have furnished the motives of the preceding discussions, and it may be well now at the close to state explicitly some of these implications. Having reduced most of the behavior of rats and other commonly used laboratory animals to complexes of innate impulses as modified by experience and then crystallized into habits, experimental workers in this field not unnaturally extend the principles

thus established as explanatory rules of human behavior. This is good; for human life unquestionably has grown out of simpler vital stock of this type, and habit evidently plays an enormous part in our own program of living. Much of education consists in the formation of proper habits. But this is not all of education or the better part of it. Nor is it all of life or the better part of it.

The first point which I wish to stress in this connection is that mankind has grown up; we have not merely enlarged and complicated the behavior patterns of rats and monkeys; we have improved upon them and added new patterns not elsewhere known. The recent attempts of some psychologists to reduce human intelligence to assemblages of habits involve an enlargement of the usual connotation of the term "habit" which has no justification in ordinary usage and which obscures certain very important characteristics of human and perhaps some other higher forms of behavior.

Watson (1919, p. 273) defines habit as a complex system of reflexes whose pattern has been individually acquired and which functions in a serial order when the individual is confronted by the appropriate stimulus. Accepting this definition, it is evident that a firmly established habit is a stabilized behavior pattern whose maintenance is dependent upon the persistence of some structural modification of the bodily organs. It is the fixation, the enduring nature of the



behavior pattern, which characterizes habit in our common use of the term.

Now, of course, the acquisition of new habits, whether simple or complex, involves a change in the structural organization. Habit *formation* is modifiable behavior, but we do not ordinarily call it a habit unless the modification of pattern persists and reappears whenever the individual "is confronted by the appropriate stimulus." But many new patterns of explicit and implicit behavior actually appear which are not thus fixed and stabilized, and to enlarge the connotation of habit formation to include every case of modifiable behavior, as Watson appears to do, is a violation of common usage which leads to (or results from?) an oversimplification of human behavior patterns.

That which is most characteristic of human cortical activity is just that flexibility or plasticity of organization which facilitates the formation of innumerable transient associational patterns which have no enduring quality. In advance of any overt act we "think through" many provisional solutions of a problem of conduct, discarding one after another before the right course of overt action is found. These imaginary acts which are conceived only to be rejected are not habits any more than are the rat's aimless wanderings before he has acquired a problem-box habit. These particular associational patterns may never again appear. It is the capacity to do this sort

of thing that most sharply differentiates men from rats. These powers of imagination, of "free association," of invention, of idealization, depend upon the fluidity of the intracortical organization and the preservation of its plasticity. Just in proportion as this organization becomes fixed in stable patterns and the behavior congeals in habitual molds do "constructive thinking" and originality of behavior regress, and we revert to lower levels of more stable conduct.

The human type of plasticity of behavior is the very antithesis of habit; it is a new vital mode, though its rudiments are readily discernible in the rat's capacity to form new habits. New vital patterns have come in at every turn of the road of evolutionary progress, for evolution is creative in the sense that the elements of organization are recombined in original ways at every transition from type to type. This is a natural process and demands no appeal to mystical or supernatural agencies.

Somewhere in the history of primate evolution, during the course of progressive elaboration of the apparatus of cortical associations, sufficient complexity of tissue and plasticity of organization was attained to facilitate rapid learning, the retention of memories of single experiences and the abstraction from these of certain features common to all of them, and finally the integration of these common features into symbolic patterns. Symbolic thinking is a new

kind of function, though the steps by which it was fashioned can probably be traced, just as we have already succeeded in charting in outline the progressive elaboration of the neurologic mechanisms employed.

The revolutionary nature of the change in behavior patterns colligated with the appearance of symbolic thinking can hardly be exaggerated. Once this change has been consummated, habitude as the dominant behavior pattern gives way to insight in terms of generalization of experience, foresight of possible future consequences of action, the fabrication of consciously directed purposes, deliberative choice in view of these purposes, and finally the development of ideals of character and the shaping of daily conduct with a view to molding the personality in conformity with these ideals.

We have not the slightest evidence that these powers are possessed in any degree by any of the lowest mammals, though we can see, very dimly, their sources and we can trace some of the stages in their elaboration. They seem to have grown up within that capacity for individually modifiable behavior which is a common feature of all living things (Herrick, 1924, chap. xix).

Our contention, then, is that certain functions which we know best introspectively are realities of experience and as such are susceptible of scientific study as well as of practical use. There is nothing to

be gained by ignoring them in a study of human conduct and there is much of value that will inevitably be lost.

Teachers of psychology for more than a generation past have been accustomed to include in their textbooks more or less extended reference to the anatomy and physiology of the nervous system. Now these matters are significant for introspective psychologists only in so far as it is recognized that introspectively known experience is in some real sense in organic relationship with bodily organs. Otherwise they are irrelevant.

If mind as we know it phenomenally, that is, as an awareness process, is not knit into the sequence of living as a natural event, if mind is epiphenomenon, parallel phenomenon, by-product, or any other sort of pseudophenomenon and not a natural process integrated with the rest of living as a unitary sequence approachable with the ordinary technique of natural science, then introspective psychology can have no possible use for any of the lumber of the objective sciences. Nor, on this supposition, can any experience examined only introspectively have any place in natural science.

On the other hand, if that experience which we objectify and that experience which we do not objectify are alike organic parts of the natural process of orderly living, then we have found a common ground on which introspective psychology and ob-

jective psychology can work together in peace and harmony and with mutual advantage.

It should be noted here that the radical behaviorist's aversion to the conventional treatment of consciousness is directed in the main to the structural psychologist's figment of a detached or detachable psychic entity, whether static or dynamic, which eludes scientific study. A thoroughgoing functional view of the awareness process avoids much of this difficulty by articulating the consciousness phenomenally with other vital processes without, however, professing to clarify the mechanism of the relationships of mind and body. All of the data of experience can be approached empirically without insisting that such an approach be preceded by a full understanding of the underlying questions or an adjudication of vexatious philosophical problems, as Rosenow (1923, 1925) and Carr (1925) have illustrated.

Hunter (1924*a*, p. 28) seems to assume that a functional psychologist must be philosophically an interactionist, an imputation that some of us repudiate vehemently. If this unjustifiable imputation is eliminated from Hunter's discussion, then the behaviorists and the introspective psychologists of the functional school may find a common meeting place for their very diverse activities, except for one additional feature. Speaking for myself, at least, I am unable to admit that the only observable (or experienced) feature of conscious behavior which distin-

guishes it from, say, reflex behavior is the sort of irreversible relationship to which Hunter calls attention. The experience of recognizing the color yellow is an observable phenomenon, and it is as truly a part of my organic reaction to a flame as is my cry of "fire!"

The various enterprises, of late so energetically prosecuted, to formulate something that can be called psychology with the concepts of consciousness and awareness expunged have, until now, left some of us who are not psychologists in a somewhat dazed condition. The "objective psychologists" themselves seem to have fared but little better, if one may judge by the trouble they are experiencing in coming to an agreement upon a definition of their denatured science. Having distilled off and discarded that spiritual essence of behavior which seems to have intoxicated their elders with its heady mysticism, these younger experimentalists are evidently still in doubt about what portion of the residue is really psychology.

To the biologist most of this newest psychology seems like very orthodox physiology—good of its kind and worthy of all possible encouragement. The pursuit of such studies in a physiological laboratory excites no comment, but traditionally the product of a psychological laboratory is expected to have a distinctive flavor or bouquet other than the smelly effluvia usually associated with experimental physiology. And if in the process of the purification of psy-

chology from its mysticism this bouquet has been lost, one is perhaps tempted to cover up the deficiency by pasting the old label on the outside of the bottle.

But is awareness itself necessarily a mystic essence? Is it possible to remove the mysticism and still have left a consciousness, introspectively experienced, which articulates with the rest of natural science in both the biological and the psychological realms? The latter question seems to be answered in the negative by most of the objective psychologists. This seems incomprehensible to the biologist. It may possibly be explained as a defense reaction. Having waged a bitter (and successful) fight to secure recognition of objective methods in psychological laboratories, it is not unnatural that they should break off all relations with the introspectionists as soon as they are in a position to do so. Though this may be good tactics at the moment, it does not follow that it is good scientific method.

In my conversations with some of the behaviorists I experience great difficulty in finding a common ground for discussion, and this apparently rests on some subtle differences in definition of terms which have not been clearly expressed. These psychologists have found the metaphysical postulates of some of the older psychological schools so out of harmony with any possible scientific approach that they seem incapable of appreciating that consciousness may be and is a recognizable phenomenon, even though we

have not yet succeeded in arriving at exact scientific expression and analysis of what consciousness is. There are not a few other scientifically recognized processes which remain in the same unsatisfactory state—gravitation, chemical affinity, and life, to mention three illustrations.

Hunter (1924) has recently said of the behaviorists, "We do not make of 'consciousness' a separate aspect of the universe," and here, of course, he parts company once for all with the parallelists and all others who place mind in a separate category outside the pale of scientific treatment. But not all who introspect are parallelists, and some of us feel that while we are having introspective experience we still are organisms and that our awareness is just as truly an act of living as is our breathing and hence is a natural process.

My awareness during bodily activity while it is in process is a natural function of protoplasm just as truly as muscular contraction is a natural function of other and differently constituted protoplasm. The scientific evidence for the colligation of these two functions with their respective organs is as convincing in the one case as in the other, and it is of exactly the same sort. Consciousness is no more a "non-physical entity," to quote another recent writer, than is muscular contraction or any other bodily function, and the fact that it is a different sort of a function which has in the past been submerged in obscuran-



tism should not blind our eyes to the scientific evidence that it is a natural, not a mystical, process.

The experiments performed by the behaviorists on human subjects point in the same direction, and their failure to recognize that the consciousness of the act knits into the causal sequence of events in the same way as do the other bodily processes involved is unfortunate. The neglect of this factor in the human behavior complex, so far from simplifying the problem, only further befogs the issue, as do also the ingenious devices invoked to explain away that awareness which nevertheless always intrudes, however unwelcome.

Mind as cause is, in fact, the most significant of all of the progressive factors in evolution; it has come to full expression in consciously fabricated purposes<sup>1</sup> and ideals only within the (relatively) few thousand years that mankind has occupied the earth. The few centuries during which scientific knowledge of nature and the apparatus of social control have been purposefully

<sup>1</sup> Here and in some of my previous writings where the terms "purpose" or "apparent purposefulness" have been employed some critics have protested that this is non-behavioristic and an appeal to metaphysical animistic categories. I wish to make clear, if possible, that no such implication is justifiable. In my use of these terms I am speaking mechanistically, whether referring to "apparently purposeful" unconscious biological adaptations, where the "end" to be attained is fixed by past racial experience, as in reflex, or to conscious purposes, where the objective sought is clearly envisaged in imagination. In short, my point of view is as behavioristic as that of Tolman (1925) in his recent discussion of purpose and cognition.

enlarged have seen phenomenally rapid development of man's capacity for control of nature and of his own destiny.

The key to biological efficiency everywhere is *control*, a control which is internally determined. Every animal does control his behavior to some extent by virtue of his internal organization. This organization, this inner nature, has grown gradually through the exercise of his own innate powers in adjustment to situations as they arise. It is a creation of his racial and individual biological history. General physiology reveals the procedures employed in this biological control, some of the most important of which have been described by Child (1924).

Intelligence, reason, abstraction, idealization, in mankind are also part of the biological equipment of the control of behavior, but on a new and higher plane. We are more efficient in controlling the physical world in which we must live than are the beavers, and we can make more adequate preparation for the winter's frost and for other future contingencies than they can. Year by year we are becoming more efficient in the transmission of accumulated experience by oral and written tradition. In our social relations we are slowly learning that honesty is the best policy and that morality pays bigger dividends than anti-social practices. And, above all, we are gradually perfecting the technique of self-control as a means of character-building.

This control is real. It is limited, to be sure; no one of us is free to flout the laws of nature or to choose whether he will or will not conform his conduct to them. But the knowledge of these laws and ability to project their operations into the future give to us a technique of control denied to the brutes. I can "make up my mind" to become a physician, and I can deliberately subject myself to the hardships of the rigorous training necessary to qualify for this profession. It is not within my power, as I leave the high school with my diploma, to enter at once into a lucrative practice; but it is within my power to imagine myself doing so ten years hence, to determine that I will do so, and to take the first step necessary to create in myself the capacity to do so. All of these steps and all of the succeeding steps during the long apprenticeship are causally related, and not the least of these causes is the will to achieve, a will that can be strengthened by use and guided by wise instruction as truly and as efficiently as my muscles and "wind" can be trained for a foot race.

In so far as I do thus consciously participate in the shaping of daily conduct in the light of its future effects, I am also a partner in the business of shaping my own inner nature; I am engaged in character-building as a purposeful enterprise. My part in this process is real. I can and do control, to some extent, my own destiny in ways that rats do not and cannot, for I have powers of imagination, of ratiocination, of

prevision, of idealization, and of volition which they lack. There are reserves in human nature that can be drawn upon in times of stress and doubt which enable me to shape my conduct with more efficiency, not merely in view of its effect upon the present situation, but also in view of its effect upon myself and my future career.

The genetic history of these processes has been discussed by Mead (1925), with emphasis on the social implications of this forward reference. The development of self-consciousness is contingent upon ability to take up the attitudes of others toward ourselves and to respond to these attitudes. It is not merely that we set the self over against the others but also that we react to the others in view of our own understanding of their relations to us.

The individual in such an act is a self. If the cortex has become an organ of social conduct, and has made possible the appearance of social objects, it is because the individual has become a self, that is, an individual who organizes his own response by the tendencies on the part of others to respond to his act. He can do this because the mechanism of the vertebrate brain enables the individual to take these different attitudes in the formation of the act.

Thus the socializing of experience on the human plane is radically different from that of lower animal planes as seen, for instance, in insects.

These are lawful processes; they are not arbitrary acts of an extraneous omnipotence. And they are

very real factors in human behavior. They are under personal control and social control, like all other vital processes. And this control is of a different order from that seen in an ant hill or a rat hole. The mechanist regards all vital functions as causally related with simpler inorganic processes; but they are not identical with these latter, for in living substance the physico-chemical processes are combined in patterns not found elsewhere (p. 287). Similarly, certain functions of the cerebral cortex are in causal relationship with simpler physiological processes; but these latter are here organized in distinctive patterns, one of whose characteristics is the presence of an awareness while these events are in process. And when this awareness attains the level of human self-consciousness with capacity for symbolic thinking and the idealization and socialization of experience, in the present state of our knowledge it is futile to try to formulate these recondite cortical processes in terms of any known patterns of elementary mechanism. We know these processes as personal experience, and we can observe their effects as objective behavior, but what they are remains obscure.

Despite these limitations, one does not feel justified either to ignore the introspectively known experience which he undoubtedly has or to set it aside as forever inaccessible by the scientific method. As a naturalist, I decline to sell out my most precious birth-right—namely, the right to live biologically a whole

man (physiologically and psychologically) on a naturalistic basis—for a mess of dialectic pottage.

No metaphysical postulate of necessity in the theological sense of foreordination, no fatalistic mythology of a bygone age which envisages man as a puppet all of whose acts are determined from without his own personality, no mechanistic schema which recognizes no patterns of vital energies different from those of physical chemistry as manifested in semi-permeable membranes and fat-soluble vitamins—none of these favorite devices of an oversimplified physiology measures up to the requirements of an adequate statement of the problem of human life.

We have all of these physiological functions—and more. There is no doubt about that. And we have also an understanding and inquiring mind, an insatiable curiosity, a noble ambition, a quickened sympathy, a tender affection, a social conscience, an altruistic aspiration. These are real components of human behavior; they are causative factors in human conduct.

Biologically considered, these factors have survival value under the conditions of an advanced stage of social culture; for these are the integrating bonds that hold such a community together and enable it to crowd out of their places in the sun those other communities whose more primitive ideals of personal or national self-aggrandizement yield the antisocial fruits of aggressive warfare and exploitation of neigh-

boring peoples. The history of successful colonization has shown that peaceful penetration under a political and commercial organization which yields mutual advantage to all concerned is, in the long run, the most stable form of national expansion. And where these methods have failed, as they have so often, the reason is usually to be found in reversion to antisocial practices somewhere in the program.

Woodbridge has said, "Human living is a moral event." It is also a natural event. From the standpoint of this discussion it is not necessary to pass beyond the range of the natural in order to see that it is a moral event.

The preparation of myself for future living, consciously, deliberately, purposefully, by well-chosen discipline, is a thing which apparently the rat cannot do. On a higher plane of behavior my own foreknowledge of the probable future consequences of my action and especially of the effects of conduct upon character is a strictly biological process in one of its aspects. This process may have moral value, but it is not the task of the biologist—as biologist—to evaluate the process from that standpoint.

We may pass beyond the range of the method of natural history by mathematical technique, or into the fields of aesthetics, ethics, religion, philosophy, where some other technique is more serviceable, and so perhaps gain much more than we can hope to win by close adherence to the method of natural science.

But without straying from the biological field we have reached a conclusion which is measurably satisfying and quite adequate for the cultivation of this field. We have integrated our living—all of it—as biological process. We can now accept the dictum laid down by Dewey (1925): "We must conceive the world in terms that make it possible for devotion, piety, love, beauty, and mystery to be as real as anything else." That is a great gain. For now the process of living in its entirety is approachable by the scientific method and is under control by natural procedures just in proportion as the laws of these vital processes are understood.<sup>1</sup>

Without transgressing the boundaries of biological science we can set in their places objective behavior in all of its manifestations, the structural mechanisms employed, and all kinds of subjective experience— affect, impulse, volition, the whole intellectual life, and, as soon as we consciously socialize these things, the whole moral life. So far from disregarding these intimate personal experiences, we rationalize and interpret them by articulating them with the rest of living and so have a wider and truer understanding of what living on the human plane really is—physiolo-

<sup>1</sup> Natural science employs only its own distinctive technique; it envisages a limited horizon; it does not and cannot attain universals or metaphysical absolutes. Cf. Santayana (*Jour. Philos.*, vol. 22 [1925], p. 674): "Naturalism may, accordingly, find room for every sort of psychology, poetry, logic and theology if only they are content with their natural places."



gically, psychologically, aesthetically, socially, morally. We have found place in our natural system for purpose, imagination, appreciation, sentiment, ethics, religion, faith, hope, and charity, though disclaiming any ability by the method here adopted to explore fully these nobler functions in any but their biological relationships.

From the personal standpoint, the cultivation of these finer "humanities," appreciations, and aspirations is what makes life worth living at the existing stage of human culture. We properly cherish these things and we repudiate any movement, whether in the guise of philosophy, science, free art, personal liberty, or any other, which would disarticulate these integral components of right living from the vital unity that I call myself. I need these things in the serious business of living, and I find pragmatically that in proportion as they are integrally woven into the fabric of my life as a whole this life develops in satisfying patterns.

Men are bigger and better than rats.

## BIBLIOGRAPHY

- BAGLEY, C., and RICHTER, C. P. 1924. Electrically excitable region of the forebrain of the alligator. *Arch. Neurol. Psychiat.*, vol. 11, pp. 257-263.
- BERITOFF, J. S. 1924. On the fundamental nervous processes in the cortex of the cerebral hemispheres. I. *Brain*, vol. 47, pp. 109-148.
- BIANCHI, L. 1922. The mechanism of the brain and the function of the frontal lobes. Edinburgh.
- BOLTON, J. S. 1914. The brain in health and disease. London.
- BRODMANN, K. 1909. *Vergleichende Lokalisationslehre der Grosshirnrinde*. Leipzig.
- BROWN, H. C. 1925. The material world—Snark or Boojum? *Jour. Philos.*, vol. 22, pp. 197-214.
- BURNETT, T. C. 1912. Some observations on decerebrate frogs, with special reference to the formation of associations. *Amer. Jour. Physiol.*, vol. 30, pp. 80-87.
- CARR, H. A. 1925. *Psychology. A study of mental activity*. New York.
- CASON, HULSEY. 1924. Criticisms of the laws of exercise and effect. *Psychol. Rev.*, vol. 31, pp. 397-417.
1925. The physical basis of the conditioned response. *Amer. Jour. Psychol.*, vol. 36, pp. 371-393.
- 1925*a*. General aspects of the conditioned response. *Psychol. Rev.*, vol. 32, pp. 298-316.
- 1925*b*. The conditioned reflex or conditioned response as a common activity of living organisms. *Psychol. Bull.*, vol. 22, pp. 445-472.
- CHILD, C. M. 1921. *The origin and development of the nervous system*. University of Chicago Press.
1924. *Physiological foundations of behavior*. New York.
- 1924*a*. The problem of pattern in organisms. *Amer. Nat.*, vol. 58, pp. 115-126, 322-336.

1925. The individual and environment from a physiological viewpoint. In: *The child, the clinic and the court*, New York, New Republic, Inc., pp. 126-155.
- COGHILL, G. E. 1909. The reactions to tactile stimuli and the development of the swimming movement in embryos of *Diemyctylus torosus* Eschscholtz. *Jour. Comp. Neur.*, vol. 19, pp. 83-105.
1913. The primary ventral roots and somatic motor column of *Amblystoma*. *Jour. Comp. Neur.*, vol. 23, pp. 121-143.  
Correlated anatomical and physiological studies of the growth of the nervous system of *Amblystoma*.
1914. Part I. *Jour. Comp. Neur.*, vol. 24, pp. 161-233.
1916. Part II. *Jour. Comp. Neur.*, vol. 26, pp. 247-340.
1924. Part III. *Jour. Comp. Neur.*, vol. 37, pp. 37-69.
- 1924a. Part IV. *Jour. Comp. Neur.*, vol. 37, pp. 71-120.
1926. Part V. *Jour. Comp. Neur.*, vol. 40, pp. 47-94.
- 1926a. Part VI. *Jour. Comp. Neur.* (in press).
- COLE, L. W. 1925. Lapses influenced by similarity. *Psychol. Rev.*, vol. 32, pp. 216-223.
- CRAIGIE, E. H. 1920. On the relative vascularity of various parts of the central nervous system of the albino rat. *Jour. Comp. Neur.*, vol. 31, pp. 429-464.
1921. The vascularity of the cerebral cortex of the albino rat. *Jour. Comp. Neur.*, vol. 33, pp. 193-212.
1925. Postnatal changes in vascularity in the cerebral cortex of the male albino rat. *Jour. Comp. Neur.*, vol. 39, pp. 301-324.
- 1925a. An introduction to the finer anatomy of the central nervous system based upon that of the albino rat. University of Toronto Press.
- CROSBY, ELIZABETH C. 1917. The forebrain of *Alligator mississippiensis*. *Jour. Comp. Neur.*, vol. 27, pp. 325-402.
- DASHIELL, J. F. 1925. A physiological-behavioristic description of thinking. *Psychol. Rev.*, vol. 32, pp. 54-73.

- DEWEY, JOHN. 1922. Knowledge and speech reactions. *Jour. Philos.*, vol. 19, pp. 561-570.
1925. Experience and nature. Chicago.
- DÖLLKEN, I. 1907. Beiträge zur Entwicklung des Säugerhirns, Lage und Ausdehnung des Bewegungscentrums der Maus. *Neurol. Centralbl.*, Bd. 26, pp. 50-59.
- DONALDSON, H. H. 1924. The rat. *Memoirs of the Wistar Inst.*, no. 6, 2d ed. Philadelphia.
- DRESEL, K. 1924. Die Funktionen eines Grosshirn- und Striatumlosen Hundes. *Klin. Wochenschr.*, 3 Jahrg., no. 49, pp. 2231-2233.
- EDINGER, L., and FISCHER, B. 1913. Ein Mensch ohne Grosshirn. *Arch. f. ges. Physiol.*, Bd. 152, pp. 1-27.
- EYCLESHYMER, A. C. 1906. The habits of *Necturus maculosus*. *Amer. Nat.*, vol. 40, pp. 123-136.
- FORTUYN, A. E. B. D. 1914. Cortical cell-lamination of the hemispheres of some rodents. *Arch. Neurol. Psychiat.*, London, vol. 6, pp. 221-354.
- FRANZ, S. I. 1907. On the functions of the cerebrum: The frontal lobes. *Arch. Psychol.*, no. 2, pp. 1-64.
1921. Cerebral-mental relations. *Psychol. Rev.*, vol. 28, pp. 81-95.
- FRANZ, S. I., SCHEETZ, M. E., and WILSON, A. A. 1915. The possibility of recovery of motor function in long-standing hemiplegia. A preliminary report. *Jour. Amer. Med. Assoc.*, vol. 65, pp. 2150-2154.
- GOLTZ, FR. 1892. Der Hund ohne Grosshirn. *Arch. f. ges. Physiol.*, Bd. 51, p. 570.
- GRAY, P. A. 1924. The cortical lamination pattern of the opossum, *Didelphys virginiana*. *Jour. Comp. Neur.*, vol. 37, pp. 221-263.
- GRAY, P. A., and TURNER, E. L. 1924. The motor cortex of the opossum. *Jour. Comp. Neur.*, vol. 36, pp. 375-385.

- GRÜNSTEIN, A. 1924. Grosshirnrinde und Corpus striatum. *Zeits. f. ges. Neurol. u. Psychiat.*, Bd. 90, pp. 260-262.
- HEAD, HENRY (and OTHERS). 1920. *Studies in neurology*. 2 vols. London.
- HERRICK, C. JUDSON. 1905. A functional view of nature as seen by a biologist. *Jour. Philos.*, vol. 2, pp. 428-438.
1913. Some reflections on the origin and significance of the cerebral cortex. *Jour. Animal Behavior*, vol. 3, pp. 222-236.
1914. The medulla oblongata of larval *Amblystoma*. *Jour. Comp. Neur.*, vol. 24, pp. 343-427.
1915. Introspection as a biological method. *Jour. Philos.*, vol. 12, pp. 543-551.
1917. The internal structure of the midbrain and thalamus of *Necturus*. *Jour. Comp. Neur.*, vol. 28, pp. 215-348.
1920. Irreversible differentiation and orthogenesis. *Science*, n.s., vol. 51, pp. 621-625.
1921. A sketch of the origin of the cerebral hemispheres. *Jour. Comp. Neur.*, vol. 32, pp. 429-454.
1922. *Introduction to neurology*. 3d ed. Philadelphia.
- 1922a. Functional factors in the morphology of the forebrain of fishes. *Libro en Honor de D. Santiago Ramón y Cajal*, vol. 1, pp. 143-204.
1924. *Neurological foundations of animal behavior*. New York.
- 1924a. Origin and evolution of the cerebellum. *Arch. Neurol. Psychiat.*, Chicago, vol. 11, pp. 621-652.
- 1924b. The nucleus olfactorius anterior of the opossum. *Jour. Comp. Neur.*, vol. 37, pp. 317-359.
- 1924c. The amphibian forebrain. I. *Jour. Comp. Neur.*, vol. 37, pp. 361-371.
1925. Self-control and social control. In: *The child, the clinic and the court*, New York, New Republic Inc., pp. 156-177.
- 1925a. The amphibian forebrain. III. *Jour. Comp. Neur.*, vol. 39, pp. 433-489.

- 1925*b*. The natural history of purpose. *Psychol. Rev.*, vol. 32, pp. 417-430.
- HERRICK, C. JUDSON, and COGHILL, G. E. 1915. The development of reflex mechanisms in *Amblystoma*. *Jour. Comp. Neur.*, vol. 25, pp. 65-85.
- HERRICK, C. L. 1907. The nature of the soul and the possibility of a psycho-mechanic. *Psychol. Rev.*, vol. 14, pp. 205-228.
- HINES, MARION. 1922. Studies in the growth and differentiation of the telencephalon in man. The fissura hippocampi. *Jour. Comp. Neur.*, vol. 34, pp. 73-171.
1923. The development of the telencephalon in *Sphenodon punctatum*. *Jour. Comp. Neur.*, vol. 35, pp. 483-537.
- HOBHOUSE, L. T. 1915. *Mind in evolution*. 2d ed. London.
- HOLMES, GORDON, and LISTER, W. T. 1916. Disturbances of vision from cerebral lesions, with special reference to the cortical representation of the macula. *Brain*, vol. 39, pp. 34-73.
- HOLMGREN, NILS. 1922. Points of view concerning forebrain morphology in lower vertebrates. *Jour. Comp. Neur.*, vol. 34, pp. 391-459.
- HOLMGREN, NILS, and VAN DER HORST, C. J. 1925. Contribution to the morphology of the brain of *Ceratodus*. *Acta Zoologica*, Bd. 6, pp. 59-165.
- HOLT, E. B. 1914. *The concept of consciousness*. New York.
- HUBER, G. C., and CROSBY, E. C. 1926. On thalamic and tectal nuclei and fiber paths in the brain of the American alligator. *Jour. Comp. Neur.*, vol. 40, pp. 97-227.
- HUNTER, W. S. 1913. The delayed reaction in animals and children. *Behavior Monogr.*, vol. 2, no. 1, pp. 1-86.
1917. Delayed reactions in a child. *Psychol. Rev.*, vol. 24, pp. 74-87.
1924. The symbolic process. *Psychol. Rev.*, vol. 31, pp. 478-497.
- 1924*a*. The problem of consciousness. *Psychol. Rev.*, vol. 31, pp. 1-31.

- INGVAR, SVEN. 1923. On thalamic evolution. *Acta Med. Scand.*, vol. 59, pp. 696-709.
- ISENSCHMID, R. 1911. Zur Kenntnis der Grosshirnrinde der Maus. *Abh. k. Preuss. Akad. Wiss., Phys. Math. Classe, Anhang, Abh. III*, pp. 1-46.
- JAMES, WILLIAM. 1907. The energies of men. *Science, n.s.*, vol. 25, pp. 321-332.
- JELLINEK, A., and KOPPÁNYI, T. 1923. Lernfähigkeit gehirnverletzter Ratten. *Akad. Wissen. in Wien, Akad. Anz.*, No. 17.
- JOHNSON, H. M. 1925. The definition and measurement of attention. *Amer. Jour. Psychol.*, vol. 36, pp. 601-614.
- JOHNSTON, J. B. 1915. The cell masses in the forebrain of the turtle, *Cistudo carolina*. *Jour. Comp. Neur.*, vol. 25, pp. 393-468.
1916. Evidence of a motor pallium in the forebrain of reptiles. *Jour. Comp. Neur.*, vol. 26, pp. 475-479.
- 1916a. The development of the dorsal ventricular ridge in turtles. *Jour. Comp. Neur.*, vol. 26, pp. 481-505.
1923. Further contributions to the study of the evolution of the forebrain. *Jour. Comp. Neur.*, vol. 35, pp. 337-481; vol. 36, pp. 143-192.
- JONES, F. WOOD. 1916. *Arboreal man*. London.
- JOSEY, C. C. 1922. *The social philosophy of instinct*. New York.
- KAPPERS, C. U. ARIËNS. 1913. Cerebral localization and the significance of sulci. *Internat. Congr. Med., Anat. and Embryol.*, London, pp. 273-392.
1914. Über das Rindenproblem und die Tendenz innerer Hirnteile sich durch Oberflächen-Vermehrung statt Volumzunahme zu vergrössern. *Folia Neurobiol.*, Bd. 8, pp. 507-531.
1921. Die vergleichende Anatomie des Nervensystems der Wirbeltiere und des Menschen. II Abs. Haarlem.
1923. Le développement ontogénétique du corps strié des oiseaux en comparaison avec celui des mammifères et de l'homme.

- Arch. Suisses de Neurol. et de Psychiatrie, vol. 13, pp. 348-370.
- KINGSBURY, B. F. 1913. The fitness of organisms from an embryologist's viewpoint. *Science*, n.s., vol. 38, pp. 174-179.
- KOFFKA, KURT. 1924. *The growth of the mind*. New York.
- KÖHLER, W. 1925. *The mentality of apes*. New York.
- KOPPÁNYI, TH., and PEARCY, J. FRANK. 1925. Comparative studies on the excitability of the forebrain. *Amer. Jour. Physiol.*, vol. 71, pp. 339-343.
- LASHLEY, K. S. 1912. Visual discrimination of size and form in the albino rat. *Jour. Animal Behavior*, vol. 2, pp. 310-331.
1920. Studies of cerebral function in learning. I. *Psychobiology*, vol. 2, pp. 55-135.
1921. Studies. II. The effects of long continued practice upon cerebral localization. *Jour. Comp. Psychol.*, vol. 1, pp. 453-468.
- 1921*a*. Studies. III. The motor areas. *Brain*, vol. 44, pp. 255-285.
1922. Studies. IV. Vicarious function after destruction of the visual area. *Amer. Jour. Physiol.*, vol. 59, pp. 44-71.
1923. The behavioristic interpretation of consciousness. *Psychol. Rev.*, vol. 30, pp. 237-272, 329-353.
- 1923*a*. Temporal variation in the function of the gyrus precentralis in primates. *Amer. Jour. Physiol.*, vol. 65, pp. 585-602.
1924. Studies. V. The retention of motor habits after destruction of the so-called motor areas in primates. *Arch. Neurol. Psychiat.*, Chicago, vol. 12, pp. 249-276.
- 1924*a*. Studies. VI. The theory that synaptic resistance is reduced by the passage of the nervous impulse. *Psychol. Rev.*, vol. 31, pp. 369-375.
1926. Studies. VII. The relation between cerebral mass, learning and retention. *Jour. Comp. Neur.* (in press).



- LASHLEY, K. S., and FRANZ, S. I. 1917. The effects of cerebral destruction upon habit formation and retention in the albino rat. *Psychobiology*, vol. 1, pp. 71-139.
- LAUGHTON, N. B. 1924. Studies on the nervous regulation of progression in mammals. *Amer. Jour. Physiol.*, vol. 70, pp. 358-384.
- LILLIE, RALPH S. 1923. *Protoplasmic action and nervous action.* University of Chicago Press.
- LOTKA, ALFRED J. 1925. *Elements of physical biology.* Baltimore.
- MCDUGALL, WILLIAM. 1923. Purposive or mechanical psychology? *Psychol. Rev.*, vol. 30, pp. 273-288.
- MACMILLAN, W. D. 1925. Some mathematical aspects of cosmology. *Science*, n.s., vol. 62, pp. 63-72, 96-99, 121-127.
- MARIE, P., and BÉHAGUE, P. 1919. Syndrome de désorientation dans l'espace, consecutif aux plaies profondes du lobe frontal. *Rev. Neurologique*, Ann. 26, pp. 3-14.
- MARIE, P., BOUTTIER, H., and VAN BOGAERT, L. 1924. Sur un cas de tumeur préfrontale droit. Troubles de l'orientation dans l'espace. *Rev. Neurologique*, Ann. 31, tome 2, pp. 209-221.
- MEAD, G. H. 1925. The genesis of the self and social control. *Internat. Jour. of Ethics*, vol. 35, pp. 251-277.
- MINOT, C. S. 1902. The problem of consciousness in its biological aspects. *Science*, n.s., vol. 16, pp. 1-12.
- MONAKOW, C. VON. 1910. *Aufbau und Lokalisation der Bewegungen beim Menschen.* Arb. hirnanatom. Inst. Zürich, Bd. 5, pp. 1-37; also in *Bericht ü. d. IV Kongress f. exp. Psychologie in Innsbruck*, 1910.
- MORGAN, C. LLOYD. 1894. *An introduction to comparative psychology.* London.
- NAÑAGAS, J. C. 1922. Anatomical studies on the motor cortex of *Macacus rhesus*. *Jour. Comp. Neur.*, vol. 35, pp. 67-96.
- OBENCHAIN, J. B. 1925. *The brains of the South American mar-*

- supials, *Caenolestes* and *Orolestes*. *Field Mus. Nat. Hist. Pub.* 224, Zoöl. Series, vol. 14, pp. 175-232.
- ODEN, R., and FRANZ, S. I. 1917. On cerebral motor control: the recovery from experimentally produced hemiplegia. *Psychobiology*, vol. 1, pp. 33-49.
- OGDEN, R. M. 1925. Crossing the Rubicon between mechanism and life. *Jour. Philos.*, vol. 22, pp. 281-293.
- PAVLOV, I. 1923. Die normale Tätigkeit und allgemeine Konstitution der Grosshirnrinde. *Skandin. Archiv f. Physiol.*, Bd 44, pp. 32-41.
- PIKE, F. H. 1909. Studies in the physiology of the central nervous system. I. The general phenomena of spinal shock. *Amer. Jour. Physiol.*, vol. 24, pp. 124-152.
1912. Studies. II. The effect of repeated injuries to the spinal cord during spinal shock. *Amer. Jour. Physiol.*, vol. 30, pp. 436-450.
1913. The nervous mechanism of motor learning and habit formation. *Trans. 4th Internat. Cong. on Sch. Hyg.*, Buffalo, 1913.
- PRINCE, M. 1914. *The unconscious*. New York.
- RABL-RÜCKHARD, H. 1883. Das Grosshirn der Knochenfische und seine Anhangsgebilde. *Arch. f. Anat. (u. Physiol.)*, pp. 279-322.
- RAMÓN Y CAJAL, S. 1909-1911. *Histologie du système nerveux* 2 vols. Paris.
- REESE, A. M. 1906. Observations on the reactions of *Cryptobranchus* and *Necturus* to light and heat. *Biol. Bull.*, vol. 11, pp. 93-99.
- REISER, O. L. 1924. A monism of creative behavior. *Jour. Philos.*, vol. 21, pp. 477-491.
- RICHTER, C. P. 1922. A behavioristic study of the activity of the rat. *Comp. Psychol. Mono.*, vol. 1, no. 2, pp. 1-55.
- RIDDOCH, G. 1917. Dissociation of visual perceptions due to oc-

- capital injuries, with special reference to appreciation of movement. *Brain*, vol. 40, pp. 15-57.
- RITTER, W. E. 1919. *The unity of the organism*. Boston.
- RIVERS, W. H. R. 1922. *Instinct and the unconscious*. 2d ed. Cambridge University Press.
- ROBERTSON, FORD. 1920. The relations of infections to mental disorders. *Jour. Mental Science*, vol. 66, pp. 227-233.
- ROGERS, F. T. 1916. Contribution to the physiology of the stomach. XXXIX. The hunger mechanism of the pigeon and its relation to the central nervous system. *Amer. Jour. Physiol.*, vol. 41, pp. 555-570.
1919. Experimental studies on the brain stem. III. The effects on reflex activities of wide variations in body temperature caused by lesions of the thalamus. *Jour. Comp. Neur.*, vol. 31, pp. 17-35.
1922. Studies of the brain stem. VI. An experimental study of the corpus striatum of the pigeon as related to various instinctive types of behavior. *Jour. Comp. Neur.*, vol. 35, pp. 21-60.
- 1922a. A note on the excitable areas of the cerebral hemispheres of the pigeon. *Jour. Comp. Neur.*, vol. 35, pp. 61-66.
1924. An experimental study of the cerebral physiology of the Virginian opossum. *Jour. Comp. Neur.*, vol. 37, pp. 265-315.
- ROSENOW, CURT. 1923. Behavior and conscious behavior. *Psychol. Rev.*, vol. 30, pp. 192-216.
1925. The problem of meaning in behaviorism. *Amer. Jour. Psychol.*, vol. 36, pp. 233-248.
- ROTHMANN, H. 1923. Zusammenfassender Bericht über den Rothmannschen grosshirnlosen Hund nach klinischer und anatomischer Untersuchung. *Zeits. f. ges. Neur. u. Psychiat.*, Bd. 87, pp. 247-313.
- SAYLE, MARY H. 1916. The reactions of *Necturus* to stimuli received through the skin. *Jour. Animal Behavior*, vol. 6, pp. 81-102.

- SELLARS, R. W. 1922. Is consciousness physical? *Jour. Philos.*, vol. 19, pp. 690-694.
- SHERRINGTON, C. S. 1906. *The integrative action of the nervous system*. New York.
- SLONAKER, J. R. 1912. The normal activity of the albino rat from birth to natural death, its rate of growth and duration of life. *Jour. Animal Behavior*, vol. 2, pp. 20-42.
1924. The effect of pubescence, oestruation and menopause on the voluntary activity of the albino rat. *Amer. Jour. Physiol.*, vol. 68, pp. 294-315.
1925. Analysis of daily activity of the albino rat. *Amer. Jour. Physiol.*, vol. 73, pp. 485-503.
- SMITH, G. ELLIOT. 1908. The cerebral cortex in *Lepidosiren*. *Anat. Anz.*, Bd. 33, pp. 513-540.
1910. Some problems relating to the evolution of the brain. *The Lancet*, Jan. 1, 15, and 22, 1910.
1919. A preliminary note on the morphology of the corpus striatum and the origin of the neopallium. *Jour. Anat.*, vol. 53, pp. 271-291.
- 1919*a*. The significance of the cerebral cortex. *Brit. Med. Jour.*, vol. 1, pp. 758, 796-797; vol. 2, pp. 11-12.
1924. *The evolution of man*. Oxford.
- STONE, CALVIN P. 1922. The congenital sexual behavior of the young male albino rat. *Jour. Comp. Psychol.*, vol. 2, pp. 95-153.
1924. The awakening of copulatory ability in the male albino rat. *Amer. Jour. Physiol.*, vol. 68, pp. 407-424.
1925. The effects of cerebral destruction on the sexual behavior of rabbits. I. The olfactory bulbs. *Amer. Jour. Physiol.*, vol. 71, pp. 430-435. II. The frontal and parietal regions. *Ibid.*, vol. 72, pp. 372-385.
- SUGITA, N. 1917-1918. Comparative studies on the growth of the cerebral cortex [albino rat]. Parts I-VIII. *Jour. Comp. Neur.*, vols. 28, 29.

- THOMPSON, HELEN B. 1899. The total number of functional cells in the cerebral cortex of man (etc.). *Jour. Comp. Neur.*, vol. 9, pp. 113-140.
- TILNEY, F., and RILEY, H. A. 1923. The form and functions of the central nervous system. 2d ed. New York.
- TOLMAN, E. C. 1924. Behaviorism and purpose. *Jour. Philos.*, vol. 22, pp. 36-41.
1925. Purpose and cognition: the determiners of animal learning. *Psychol. Rev.*, vol. 32, pp. 285-297.
- TRACY, H. C. 1926. The development of motility and behavior reactions in the toadfish (*Opsanus tau*). *Jour. Comp. Neur.* (in press).
- TURNER, E. L. 1924. The pyramidal tract of the Virginian opossum (*Didelphys virginiana*). *Jour. Comp. Neur.*, vol. 36, pp. 387-397.
- VOGT, C. and O. 1920. Zur Lehre der Erkrankungen des striären Systems. *Jour. f. Psychol. u. Neurol.*, Bd. 25, p. 631.
- DE VRIES, I. 1911. De cellulaire bouw der groote-hersenschors van de muis en de veranderingen daarin na doorsnijding van het corpus callosum. Dissertation. Amsterdam.
- WANG, G. H. 1923. The relation between "spontaneous" activity and the oestrous cycle in the white rat. *Comp. Psychol. Monogr.*, vol. 2, no. 6, pp. 1-27.
- WANG, G. H., RICHTER, C. P., and GUTTMACHER, A. F. 1925. Activity studies on male castrated rats with ovarian transplants, and correlation of the activity with the histology of the grafts. *Amer. Jour. Physiol.*, vol. 73, pp. 581-599.
- WARREN, HOWARD C. 1923. The subconscious. *Scientia*, Aug., 1923. pp. 91-100.
- WASHBURN, M. F., and BENTLEY, I. M. 1906. The establishment of an association involving color-discrimination in the creek chub, *Semotilus atromaculatus*. *Jour. Comp. Neur.*, vol. 16, pp. 113-125.
- WATSON, JOHN B. 1919. *Psychology*. Philadelphia.

- WATSON, J. B., and WATSON, M. I. 1913. A study of the responses of rodents to monochromatic light. *Jour. Animal Behavior*, vol. 3, pp. 1-14.
- WAUGH, KARL T. 1910. The rôle of vision in the mental life of the mouse. *Jour. Comp. Neur.*, vol. 20, pp. 549-599.
- WHEELER, R. H. 1923. Introspection and behavior. *Psychol Rev.*, vol. 30, pp. 103-115.
- WHITE, GERTRUDE M. 1919. Association and color discrimination in mudminnows and sticklebacks. *Jour. Exp. Zoöl.*, vol. 27, pp. 443-498.
- WHITMAN, C. O. 1899. Animal behavior. *Biological Lectures*, Woods Hole, Session of 1899, pp. 285-338.
- WILSON, S. A. KINNIER, 1912. Progressive lenticular degeneration. *Brain*, vol. 34, p. 295.
1924. The old motor system and the new. *Arch. Neurol. Psychiat.*, Chicago, vol. 11, pp. 385-404.
- WINKLER, C. 1911. A tumor in the pulvinar thalami optici. A contribution to the knowledge of the vision of forms. *K. Akad. Wetensch. Amsterdam, Proc. Sec. Sci.*, vol. 13, pp. 928-939. Also in *Folia Neurobiol.*, Bd. 5, pp. 708-717.
- WINKLER, C., and POTTER, ADA. 1911. An anatomical guide to experimental researches on the rabbit's brain. Amsterdam, W. Versluys.
- WOODBIDGE, F. J. E. 1925. Behavior. *Jour. Philos.*, vol. 22, pp. 402-411.
- YERKES, R. M. 1905. The sense of hearing in frogs. *Jour. Comp. Neur.*, vol. 15, pp. 279-304.
1916. The mental life of monkeys and apes: A study of ideational behavior. *Behavior Mono.*, vol. 3, no. 1.
- YERKES, R. M., and LEARNED, B. W. 1925. Chimpanzee intelligence and its vocal expression. Baltimore.
- YOSHIDA, I. 1924. Über den Ursprung der kortikopetalen Hörbahn beim Kaninchen. *Folia Anat. Japonica*, vol. 2, pp. 289-296

## INDEX

- Abstraction, 245, 255, 350  
Acipenser, 130  
Action, conditioned, 53, 65, 142, 195, 261; reflex, *see* Reflex  
Adaptive; *see* Behavior, adaptive  
Affect; *see* Emotion  
Alligator, brain of, 79, 110, 126  
Altruism, 362  
Amblystoma, 44, 138  
Amphibia, nervous system of, 43, 73, 81, 132, 137  
Amygdala, 101, 112, 116, 150  
Apes, behavior of, 238, 265, 290  
Aphasia, 249  
Archipallium, 77, 84, 132, 151, 165  
Association: delayed, 241; mechanism of, 5, 59, 78, 98, 246, 317  
Associative memory, *see* Memory, associative  
Awareness; *see* Consciousness  
Behavior: adaptive, 22, 58, 313, 331, 362; explicit, 63, 237, 244; implicit, 63, 237, 244, 313; modifiable, 18, 35, 60, 99, 208, 237, 244, 324, 334, 349; social, 21, 325, 358, 360; spontaneous, 211, 238, 314, 318  
Birds, brain of, 79, 93  
Blood supply, of brain, 320  
Bulb, olfactory, 71, 73, 102, 129  
Capsule, internal, 110  
Cause, 17, 340, 357  
Cells, numbers of, 3  
Center: association, 125, 218, 234, 265, 334; correlation, 35, 38, 53, 134, 321; primary reflex, 39, 50, 53, 102, 132; projection, 125, 218, 221, 234; reflex, evolution of, 51  
Cerebellum, 29, 312, 333  
Character, 18, 20, 146, 358  
Choice, 336, 351  
Clastrum, 115  
Consciousness, 15, 283, 285, 300, 335, 348; apparatus of, 235, 279, 288, 328, 335, 352; equilibrium theory of, 23, 294; thalamic, 128, 145, 268  
Control, 18, 32, 123, 315, 358; cortical, 156, 215, 223, 262  
Corpus striatum, 92, 112, 261; amphibians, 74, 103; birds, 93; fishes, 103; mammals, 112; rat, 177; reptiles, 76, 79, 100, 114  
Correlation, centers of, 35, 38, 53, 134, 321  
Cortex, cerebellar, 29  
Cortex, cerebral: amphibians, 69, 71, 210; birds, 69, 75, 79, 92, 96, 127; blood supply, 321; definition, 23; dynamic action, 31, 75, 204, 213, 221, 232, 261, 266, 317; evolution, 256; fishes, 69, 71, 256; frontal, 185, 220; functions, 5, 19, 26, 51, 80, 166, 178, 208, 220, 234, 258, 268; general, 77, 101; hippocampal, 26, 74, 77, 84, 86, 124, 125, 150; layers, 85, 87, 88, 89, 158, 322; localization, 78, 95, 98, 125, 152, 174, 188, 193, 221, 247, 260; lung-fishes, 72; mammals, 70, 83, 150; motor, 64,

- 79, 95, 98, 111, 116, 153, 160, 192, 224; number of cells, 4; origin, 68; prefrontal, 232; premotor, 226; pyriform, 26, 74, 77, 85, 86, 101, 125, 126, 150; reptiles, 69, 71, 75, 101, 256; somatic, 150; vicarious function, 184
- Cyclostomes, brain of, 103
- Decerebration, 75, 93, 117, 170, 210, 262
- Determinism, 17
- Diaschisis, 212, 214
- Diencephalon, 129
- Diffusion, 56, 64, 66, 197
- Disposition, 18, 146
- Distance-receptors, 34, 148
- Dog, decerebrate, 117
- Dogfish, 71, 109
- Domestication, 240
- Dominance, physiological, 35, 58, 142, 203
- Drainage, 30, 57, 59, 64, 212, 263, 313
- Dynamogenic action: of cerebellum, 29, 312, 334; of cerebrum, 31, 75, 204, 213, 221, 232, 261, 266, 317; of striatum, 115
- Effort, 322, 327
- Emotion, 1, 98, 146, 232, 268, 323, 325, 339
- Energy, nervous, 67, 319
- Engrams, 65, 243, 246, 317, 335
- Equilibration, 29
- Equilibrium, physiological, 141, 202
- Equilibrium theory of consciousness, 23, 294
- Evolution, 17, 285, 331, 350
- Experience, 293, 300, 329, 339, 352
- Exteroceptive adjustment, 31, 123
- Extrapyramidal tracts, 223
- Facilitation, 57, 64, 203, 225, 262, 334; by use, 67, 197, 243, 265, 313
- Fishes, brain of, 71, 81, 129
- Fissure: amygdaloid, 106; endorhinal, 106; hippocampal, 150; orbital, 154; rhinal, 106, 150
- Frog, 73, 137, 210
- Gestalt*, 67
- Globus pallidus, 102, 109, 114, 116
- Gradient, physiological, 178, 203, 315
- Habit, 333, 348; apparatus of, 41, 52, 67, 143, 166, 178, 349; kinesthetic, 171, 185, 188, 197; visual, 169, 178, 199; *see* Learning
- Hand, precursor of cortex, 42
- Hemisphere, cerebral, 72, 102, 128, 148
- Heredity, 333
- Hyperstriatum, 108
- Hypopallium, 98, 104, 112, 114, 116
- Hypothalamus, 129, 135
- Hysteria, 291
- Ichthyopsida: cortex of, 69, 71, 256; thalamus of, 137
- Idealism, 305
- Ideals, 20, 325, 350
- Ideation, 245, 255
- Image, 243, 254, 264
- Imagination, 350, 359



- Impulse, 313, 325, 332  
 Induction, nervous, 30, 59, 64, 212  
 Inhibition, 28, 94, 210, 262  
 Insight, 63, 219, 237, 351  
 Instinct, 80, 98, 115, 127, 331  
 Integration, 38, 46, 146, 283, 314, 340, 350, 364  
 Intelligence; *see* Consciousness  
 Introspection, 310, 341, 351  
 Inventiveness, 63, 239, 245, 350  
 Irradiation, 56, 64, 66, 197  
  
 Language, 19, 21, 290, 327, 337  
 Learning: mechanism, 35, 41, 59, 62, 64, 98, 99, 143, 166, 178, 193, 236, 266; perceptual-motor, 41, 245; subcortical, 98, 169, 198, 203, 217; trial-and-error, 13, 36, 41, 62, 166, 195  
 Lobe: frontal, 220; pyriform, *see* Cortex, pyriform  
 Lungfishes, 72  
  
 Macroscelides, 153  
 Mammals: cortex of, 70, 83, 150; striatum of, 112; thalamus of, 139, 152  
 Marsupials; *see* Opossum, Orolestes  
 Materialism, 298, 306  
 Medulla oblongata, 55; primitive, 44  
 Memory, 9, 11, 28, 99, 178, 193, 195, 241, 244, 246, 264, 316; associative, 41, 54  
 Midbrain, 47, 133  
 Mind; *see* Consciousness  
 Modifiability; *see* Behavior, modifiable  
 Monism, 305  
 Morals, 22, 362  
  
 Motor apparatus, 42, 227  
 Mouse, cortex of, 159  
  
 Necessity, 362  
 Necturus, 47  
 Neopallium, 77, 86, 101, 108, 132, 151, 165  
 Nerve cell; *see* Neuron  
 Nerves, 2, 12  
 Neurons: cortical, 70, 84, 243, 247; growth of, 53; number of, 4; type I, 90; type II, 90, 317, 334  
 Nissl bodies, 320  
 Nucleus: caudatus, 102, 114; lentiformis, 103, 114; olfactory, 102, 108, 132; preoptic, 137  
 Number: of blood corpuscles, 3; of cells in body, 3; of cells in brain, 4; in cerebral cortex, 4; of nervous connections, 5; of rods and cones, 5  
  
 Opossum: cortex of, 84, 117, 154; striatum of, 116  
 Orolestes, 150  
 Orthogenesis, 100  
  
 Palaeopallium, 151  
 Pallium, 24, 151  
 Pattern, 286, 320, 344, 350, 362  
 Permeability, 57, 59, 61  
 Personality, 18, 146, 318, 324, 351  
 Phasic action of cortex, 120, 122, 213, 223, 261, 316  
 Phrenology, 248  
 Pigeon, brain of, 95  
 Plasticity of behavior; *see* Behavior, modifiable  
 Prediction, 19, 327, 335, 344, 359  
 Proprioceptive adjustment, 30

- Psychology, 14, 352  
 Purpose, 20, 327, 351, 357  
 Putamen, 102, 114  
 Pyramidal tract, 78, 116, 120, 156, 223  
  
 Radiations, thalamic, 82, 123, 137, 152  
 Rat, cortex of, 157, 167  
 Reaction; *see* Reflex  
 Reaction, delayed, 60, 241, 258  
 Re-education, 230  
 Reflex, 13, 27, 38, 80, 258, 331; auditory, 54; birds, 95; conditioned, 53, 65, 142, 195, 261; gustatory, 54, 76, 130; mass, 41, 116; olfactory, 72, 76, 130; postural, 121; salivatory, 54; thalamic, 147; visceral, 76, 94, 115, 130  
 Reinforcement, 28, 31, 57, 115, 203, 262, 318, 334  
 Reptiles, brain of, 75, 81, 100, 114  
 Reserves: cerebellar, 312, 333; cortical, 10, 202, 266, 273, 334, 360; thalamic, 202; vital, 312, 333  
 Resistance, to conduction, 59, 64  
 Response, conditioned; *see* Reflex. conditioned  
 Retention, 195, 198, 244  
 Ridge: amygdaloid, 106; dorsal ventricular, 104  
  
 Salamander, 43  
 Sauropsida; cortex of, 69, 75; thalamus of, 137  
 Self, 294, 360  
 Self-consciousness, 300, 360  
  
 Self-control, 358  
 Self-culture, 20, 358, 363  
 Septum: frog, 74; mammals, 151; reptiles, 76  
 Social behavior, 21, 325, 358, 360  
 Sphenodon, brain of, 107  
 Spontaneity, 211, 238, 314, 318  
 Squalus acanthias, 71, 109  
 Sturgeon, 129  
 Subconscious, 268  
 Substance, chromophilic, 320  
 Subthalamus, 137  
 Summation, 67, 197, 334  
 Symbolism, 19, 21, 245, 255, 290, 327, 335, 350  
 Synapse, 61, 64, 66, 126, 265  
 Syncytium, 66  
 Syndrome: striatal, 116, 120; thalamic, 145  
  
 Teleology, 33, 327, 331  
 Thalamus, 49, 51, 53, 62, 82, 94, 124, 128, 151  
 Toadfish, 314  
 Tone, muscular, 29, 116  
 Tonic action: of cerebellum, 29, 312; of cortex, 31, 213, 223, 261; of striatum, 116, 121, 261  
 Transfer of habits, 64, 198  
 Trigger action, 221, 312, 316, 323  
 Tubercle, olfactory, 151  
  
 Unconscious cerebration, 280  
  
 Vascularity, of brain, 320  
 Volition, 232, 315, 322, 360







