

UC-NRLF



\$B 26 033

BRICKLAYING
AND
BRICKCUTTING

H. W. RICHARDS

REESE LIBRARY
OF THE
UNIVERSITY OF CALIFORNIA.

Received , 190

Accession No. *Class.*

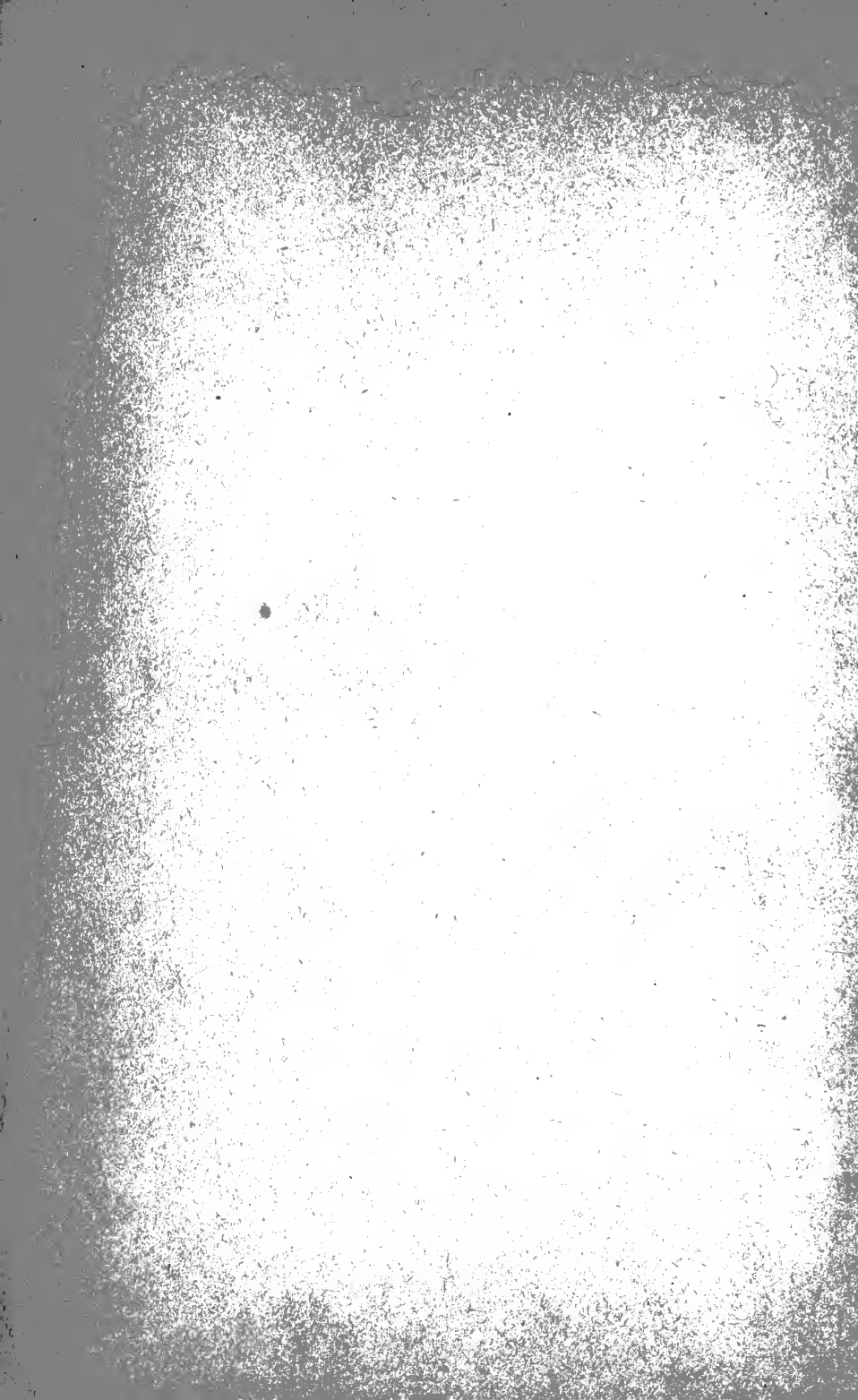

BRICKLAYING AND BRICKCUTTING

BRICKLAYING
AND
BRICKCUTTING

BY

H. W. RICHARDS

EXAMINER IN BRICKWORK AND MASONRY TO THE CITY AND GUILDS OF LONDON INSTITUTE
HEAD OF BUILDING TRADES DEPARTMENT, NORTHERN POLYTECHNIC
INSTITUTE, LONDON, N.

WITH OVER TWO HUNDRED ILLUSTRATIONS



LONGMANS, GREEN, AND CO.

39 PATERNOSTER ROW, LONDON

NEW YORK AND BOMBAY

1901

All rights reserved

TH 5501
R5

P R E F A C E

THIS Practical Elementary Treatise upon Bricklaying, Brickcutting and Setting, is designed to cover the City and Guilds of London Institute's Examination in Brickwork, both theory and practice; to meet the requirements of that portion of the Board of Education's Examination in Building Construction relating to Brickwork; and to assist Bricklayers in the principles of bonding, and cutting and setting gauged work generally.

CONTENTS

PART I

BRICKWORK

	PAGES
Plan, elevation, and section—Scale rule—Brickwork measurements— Definitions—Setting out a building—Trenches and excavations— Footings and foundations—Bonding—Dry areas or air-drains— Hollow walls—Sleeper walls—Chimney breasts, flues, etc.—Setting kitchens and close fire ranges—Broken bond—Additions to old work —Toothings—Hoop-iron bond—Plinths—Brick-nogging—Damp-proof courses—Lacing courses—Flushing, grouting, and larrying up— Jointing—House drainage	1-44

PART II

GAUGED WORK, ARCHES, ARCH-CUTTING, ETC.

Relieving arch—Invert arch—Egg-shaped sewer—Axed arches—Gauged arches—Semicircular arch—Arch with moulded soffit—Segment arch—Moulded segment—Camber arch—Moulded camber—Camber on circle—Equilateral or Gothic arch—Modified Gothic—Elliptical arch—Scheme arch—Bull's-eye arch—Semi-Gothic arch—Horse- shoe or Moorish arch—Ogee arch—Arches springing from the same pier, but differing in size—Intersection of haunches—Semicircular niche—Elliptical niche—Moulded soffit to niches—Labels to arches and niches—Oriel window—Moulding bricks for cornices, etc.— Pilasters—Cornices—Dentils—Reveals—Architraves—Panelling— Pediments—Projecting keys	45-87
---	-------

PART III

MATERIALS

The four classes of brick earths—Brickmaking—Brickburning—Colour
of bricks—Test for good bricks—Varieties of bricks, and their uses—

	PAGES
Limes and cements—Natural limes—Eminently hydraulic limes— Roman cement—Medina cement—Plaster of Paris—Artificial or manu- factured cements—Portland cement—Keene's cement—Parian cement —Sand—Substitutes for sand—Concrete—Mortar—Mode of mixing— Mortar for pointing	88-105
METHOD OF MEASURING BRICKWORK, CONCRETE, POINTING, ETC.. . .	106-113
SPECIFICATIONS	114-116
USEFUL MEMORANDA, FROM VARIOUS SOURCES	117-120
GLOSSARY OF TERMS USED.	121-126
CITY AND GUILDS OF LONDON INSTITUTE'S EXAMINATION PAPERS . . .	127-132
INDEX	133-139

LIST OF ILLUSTRATIONS

FIGS.	PAGE
1. Scale rule	3
2. Traverse joints	4
3, 4. Definitions	4
5. King closer	4
6. The square	5
7-9. Timbering for excavations	6
10. Depth of concrete	7
11-14. Footings	8, 9
15. Elevation of English bond	10
16. ditto Flemish bond	10
17. Sussex or garden wall bond	10
18. Stretching bond	10
19. Heading bond	10
20. Diagonal bond	11
21. Herring-bone bond	11
22, 23. The evil of broken traverse joints	11
24, 25. Method for drawing plans of alternate courses	12
26, 27. Plans of alternate courses, 2-brick wall, English bond	13
28, 29. ditto, $2\frac{1}{2}$ -brick wall	13
30, 31. ditto, 3-brick wall	14
32, 33. ditto, $3\frac{1}{2}$ -brick wall	14
34, 35. Plans of alternate courses, of reveal, $1\frac{1}{2}$ -brick wall, English bond	15
36, 37. ditto, splayed jambs and reveal, 2-brick wall	15
38, 39. ditto, 2-brick wall, 9" reveal	15
40, 41. ditto, 1-brick wall, $2\frac{1}{4}$ " recess	15
42, 43. ditto, 2-brick pier	15
44, 45. ditto, $2\frac{1}{2}$ -brick pier	15
46, 47. ditto, 3-brick pier	15
48, 49. Junctions of walls, 1 and $1\frac{1}{2}$ -brick, English bond	16
50, 51. ditto, $1\frac{1}{2}$ and 2-brick	16
52, 53. Plans of an obtuse angle, English bond	17
54, 55. Plans of an acute angle	17
56, 57. Plans of alternate courses, $1\frac{1}{2}$ -brick wall, Double Flemish bond	18
58, 59. ditto, 2-brick wall	18
60, 61. Junction of $1\frac{1}{2}$ double Flemish, with 2-brick wall, English bond	19

FIGS.		PAGE
62, 63.	Plans of alternate courses of reveal, 1-brick wall, double Flemish bond	19
64, 65.	Plans of alternate courses of reveals, 1½-brick wall, double Flemish bond	19
66, 67.	ditto, 2-brick pier	20
68, 69.	ditto, 2½-brick pier	20
70, 71.	Plans of obtuse angle, double Flemish bond	20
72, 73.	Plans of acute angle, ditto	20
74, 75.	Plans of alternate courses, 1½-brick wall, single Flemish bond	21
76, 77.	ditto, 2-brick wall	21
78, 79.	Plans of Sussex or garden wall bond	22
80, 81.	Plans of heading bond	22
82, 83.	Plans of stretching bond	22
84.	Section of dry area or air-drain	23
85-87.	Wall ties	24
88.	Section of hollow wall	24
89.	Basement fireplace	25
90.	Section of sleeper wall	26
91.	Section of arch in basement fireplace	26
92.	Elevation of chimney breast	27
93.	Section through same	27
94-98.	Plans through each floor of above	27
99.	Chimney bar	29
100.	Mode of carrying arch over fireplace opening	29
101.	Mode of carrying hearth	29
102.	Sectional plan through chimney breast	30
103.	Longitudinal section through hearth	30
104.	Cross-section through hearth	30
105.	Reducing width of chimney breast	31
106, 107.	Alternate courses through chimney stack, 9" work, English bond	31
108, 109.	ditto, Flemish bond	32
110, 111.	ditto, 4½" work, English bond	32
112, 113.	ditto, Flemish bond	32
114, 115.	Sketches of galvanized and copper pots	34
116.	Plan, showing ash-pit of copper	34
117.	Horizontal section through middle of copper	35
118.	Broken bond	35
119.	Battering wall	36
120.	Racking back	36
121.	Toothings	36
122.	Section of plinth	37
123.	Brick-nogging	37
124.	Lacing courses	38
125-131.	Joints in brickwork	39, 40
132, 133.	Sections through disconnecting chamber	41
134.	Disconnecting trap	42
135.	Putty tub	45
136.	Reducing box for thickness	45

LIST OF ILLUSTRATIONS.

xi

FIGS.		PAGE
137.	Reducing box for length	45
138.	Moulding box	45
139.	Radiating box	46
140.	Relieving arch	47
141.	Invert arch	48
142.	Egg-shaped sewer	48
143.	Template for axed arch	50
144.	Semicircular arch	51
145.	Template ready for traversing	51
146.	Cutting marks on template	51
147.	Centre for semicircular arch	52
148.	Segmental arch	51
149.	Gun for shewbacks	51
150.	Moulded segment	56
151.	Shoe mould for same	56
152.	Mitre for field moulded bricks	57
153-155.	Method of obtaining camber slip	58
156.	Camber arch	60
157.	ditto, moulded	60
158, 159.	Camber on circle	61
160.	Curving bricks for same	62
161.	Bond for face of arch	62
162.	Equilateral or Gothic arch	63
163.	ditto, filled in with bird's-mouth key	63
164, 165.	Modified Gothic	64
166.	Elliptical or three-centred arch	65
167.	ditto, filled in from centre of springing line	66
168.	Elliptical arch with fixed rise	66
169.	ditto, string method	66
170.	Master mould for elliptical arch, showing trammel method	67
171.	Mould in position	68
172.	Stone and brick arch	68
173.	Scheme arch	69
174.	Bull's-eye arch	69
175.	Semi-Gothic arch	70
176.	Ellipse Gothic arch	71
177.	Horse-shoe or Moorish arch	70
178.	Ogee arch	71
179.	Intersection of haunches	72
180.	Plan of niche	73
181.	Mould for same	73
182.	Elevation of head or hood of niche	74
183.	Box for cutting same	75
184, 185.	Method for curving label bricks	77
186a.	Elevation and plan of oriel	78
186b.	Bridge for holding bricks	79
187a.	Template for oriel	78
187b.	Base of pilaster	79

FIGS.		PAGE
188.	Plan of pilaster	79
189-192.	Plans of pilasters	79, 80
193, 194.	Elevation and plan of moulded head of pilaster	80
195.	Setting out dentils	82
196.	ditto, breaking round pilasters	82
197, 198.	Boxes for cutting 9" moulded reveals	83
199-203.	Architraves	84
204.	Part elevation of panel	85
205-207.	Moulds for cutting same	86
208.	Moulded pediment	86
209, 210.	Projecting keys	87
211.	Model showing cubic measurement	107
212.	Plan of brick building	111
213-215.	Diagrams, 1897 Examination	129
216-219.	ditto, 1898 Examination	130
220, 221.	ditto, 1899 Examination	131
222, 223.	ditto, 1900 Examination	132



BRICKLAYING AND BRICKCUTTING

PART I

BRICKWORK

PLAN, ELEVATION, AND SECTION.

THROUGHOUT this work the terms "plan," "elevation," and "section" will be constantly used, and for the benefit of those who do not understand these terms, the following definitions are intended:—

Plan.—A plan is a drawing representing any object as it would appear when looking down upon it. Thus, in drawing the plan of an 18" wall, not including the footings, draw the outside face-lines and the joints as Fig. 2.

Elevation.—An elevation is the view of any object when looking directly at it. It may be vertical, or at any inclination to the horizontal plane. Elevations are known as front, back, and side; hence, again illustrating by means of the 18" wall, the front and back elevations would be shown as in Fig. 3.

Section.—A section is the view of an object representing it as it would appear when cut horizontally or vertically by a plane parallel or at any angle to the face or end. For instance, a vertical section, **AB**, through Fig. 3 would appear as Fig. 4.

SCALE RULE.

It is understood by all those to whom this work will be of interest that a perfect knowledge of the scale rule and its uses is essential. To many this appears to be a simple matter, to others

a problem of some difficulty ; and to the latter a few words of explanation, it is hoped, will enable them to master it.

Measurements.—A single accent (') denotes feet, a double accent (") inches, and (°) degrees.

The Reason for the Scale Rule.—An architectural drawing is the means by which the architect arranges with his client, and makes clear to the builder or craftsman the style of building or structure to be erected, and the sizes, shape, etc., of its different parts. It is evident that this drawing, or picture of the future building, does not represent its actual size, but is what is termed *drawn to scale*, that is, every part of the whole is brought down proportionately so many times less than the actual or full size. Thus, if a drawing be to a scale of one-eighth of an inch to a foot, every foot would be represented by $\frac{1}{8}$ " ; so that a wall 96' long would actually measure 96 eighths, or 12", on the drawing ; and an opening in the wall 8' wide would appear as 8 eighths, or 1" wide.

How to read the Scale Rule.—When dealing with any particular scale, the student must remember that for the time being, and as far as he is concerned, the scale foot is actually a foot. Thus, taking a scale of 2" to a foot, he must dismiss from his mind the fact that it is 2" he is dealing with, and must treat it exactly as he would a standard foot. And, as the last-named is divided into inches, half-inches, etc., so will the scale foot be divided.

Taking off from and laying down to Scale.—In taking off any measurement from a drawing, the scale rule should be applied direct to the drawing itself. Many students make it a practice to take the measurement with the dividers, and then apply it to the scale, probably increasing the chances of error and risking damage to both the drawing and the scale rule.

For the same reason, in laying down a drawing to scale, the dividers should not be used.

When dealing with fractions of inches, it is advisable, for the sake of accuracy, to double the dimensions and halve the scale, until the fractions become whole inches. For instance, $2\frac{1}{4}$ " on the 2" scale become $4\frac{1}{2}$ " on the 1" scale, and 9" on the $\frac{1}{2}$ " scale.

How to construct a Scale.—It sometimes happens that a scale is needed that cannot be found upon an ordinary scale rule ; it then becomes necessary to construct one. In doing this it must be borne in mind that the full size, or standard measurement, is a foot, and that the desired scale will be a proportion of this foot. Thus, if a scale of one-seventh full size be required, the full size,

or a line 1' in length, should first be laid down and equally divided into seven parts. Each part will then represent a *scale* foot, and in the same way in which the standard foot is divided into twelve parts, or inches, so one of the scale feet will have to be treated.

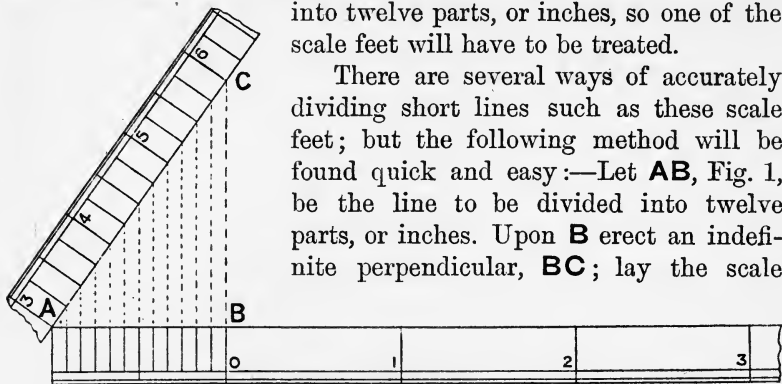

FIG. 1.

rule with twelve equal divisions, say quarter or half-inches, with the first division on **A**, and rotate till the twelfth division cuts **BC**; mark off the divisions, and drop perpendiculars from these on to **AB**. The latter will then be found to be divided into twelve equal parts, or inches.

BRICKWORK MEASUREMENTS.

The average length of a brick is $8\frac{3}{4}$ " , but with the addition of either a cross joint or a wall joint, it is reckoned as 9" .

The width is $4\frac{1}{4}$ " , and for the same reason as given above, it is considered to be $4\frac{1}{2}$ " .

The average thickness is $2\frac{3}{4}$ " , and four courses with the bed joints will measure $11\frac{1}{2}$ " , 12" , or $12\frac{1}{2}$ " , etc., according to the thickness of the joints. The usual practice is to build the work four courses to a foot.

A wall $1\frac{1}{2}$ bricks thick is usually called a 14" wall; $2\frac{1}{2}$ bricks thick, a 23" wall, whereas walls 2 bricks and 3 bricks thick are known as 18" and 27" walls respectively.

DEFINITIONS.

Course.—A course is the name given to one row of bricks in any thickness of wall, between two bed joints, as **CD**, Fig. 3.

Bed Joints.—These are the mortar joints between the courses, as **EF**, Fig. 3.

Cross Joints.—The short vertical joints at right angles to and connecting the bed joints are known as cross joints or perpend (see **GH**, Fig. 3).

Transverse Joints.—When the cross joints are continued through the thickness of the wall, they are called transverse joints, as **AB**, Fig. 2.

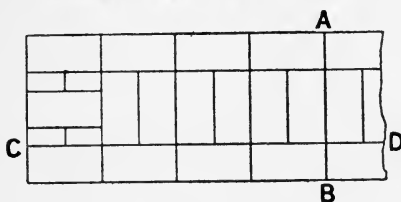

FIG. 2.

Wall Joints.—These are the joints in the thickness of and parallel to the face of the wall **CD** (Fig. 2).

Quoins.—The external angles of a wall are called quoins (see **IJ**, Fig. 3).

Stretcher.—This is the 9" face of a brick, **K** (Fig. 3).

Header.—The 4½" end of a brick, **L** (Fig. 3).

Bats.—The half of a brick is known as a 4½" bat, while any length above this and below 9" is known as a three-quarter bat.

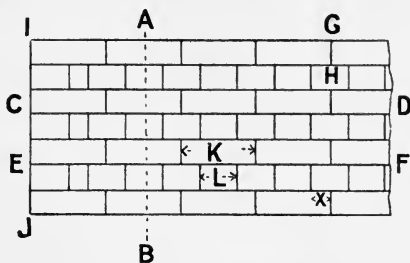

FIG. 3.

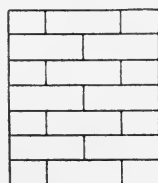

FIG. 4.

Lap.—The horizontal distance between the cross joints in two successive courses is called the lap. This should never be less than one quarter of the length of the stretcher, **X** (Fig. 3).

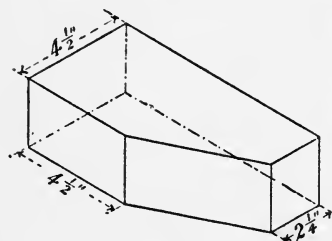

FIG. 5.

Closers (Kings and Queens).—A king closer is a brick made to appear as a header on one end and a closer on the other (Fig. 5).

A queen closer is a brick cut, if possible, 9" in length by 2¼" on the face; most usually the 9" are made up of two 4½" lengths (Fig. 2).

SETTING OUT A BUILDING.

In setting out a building, the line of frontage should first be determined, and a level or datum established by means of a stake driven into the ground; the top of which should coincide with the ground floor or basement level, as the case may be. A centre line at right angles with the front line will then serve as a guide from which to measure and stake out the walls, a similar line being drawn upon the working drawing. This system in many instances will prevent mistakes, though to attempt to give any hard-and-fast rules as to mode of procedure would be misleading, different cases demanding different treatment, to be left to the judgment of the experienced foreman.

Although it may seem a simple matter to note, yet the necessity of occasionally testing the setting-out square for accuracy must be pointed out, especially as it is such an easy matter to prove it. In Fig. 6 let **ABC** be the square; then, if correct, while **AB** and **BC** measure 3' and 4' respectively, from **A** to **C** should measure 5'. These proportions are given, as a 5' rod is usually kept on the works.

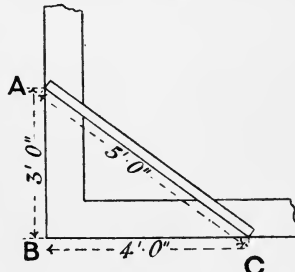

FIG. 6.

TRENCHES AND EXCAVATIONS.

Having determined the positions of the walls, test for accuracy and proceed to dig trenches. It is impossible to determine by theory how deep the trenches should be taken, although a supposed depth is given on the drawing, and taken in the quantities. It is necessary to sink the trench until a good bottom, if possible, be reached. A good foundation should consist of gravel, sand, rock (if not interspersed with clay-holes), and hard chalk (when not affected by water), etc. When this has been attained, all levels should then be taken and marked by means of stumps.

Timbering for Excavations.—In some cases, either through the depth of the trench or the nature of the soil, timbering has to be resorted to, when the methods are as follows:—

In moderately firm ground, after 3' or 4' deep, poling boards 9" × 1½" are placed at intervals opposite each other, and struts of

rough scantling, 4" \times 6", wedged downwards in between (see Fig. 7).

In looser ground, poling boards are placed close together and supported by 3" planks or walings, which in their turn are strutted. The thickness of the struts will depend upon the width of the trench, the pressure upon them, their distance apart, the strength of the walings, and the nature of the soil (see Fig. 8).

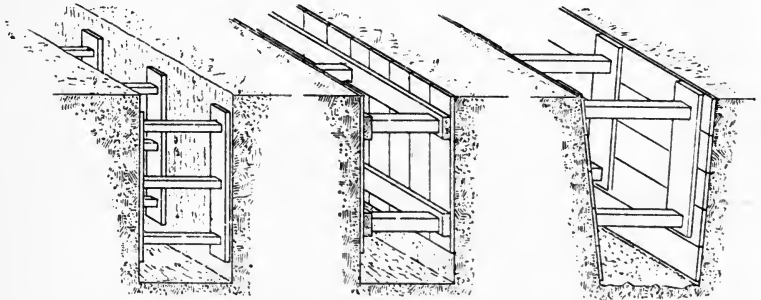

FIG. 7.

FIG. 8.

FIG. 9.

In very loose soils, such as running sand and slipping clay, the sides have to be supported at once as the excavation proceeds, and boards are used horizontally as sheeting, being kept in position by poling boards and struts (see Fig. 9).

In excavations over 5' in depth, stages every 5' in height, and supported upon the struts, become necessary.

FOOTINGS AND FOUNDATIONS.

It is not intended in the present elementary work to dwell at any length upon foundations. This important subject is reserved for a more advanced course, and foundations will therefore be dealt with only as far as is necessary.

The foundation is that portion of any structure which acts as a base upon which to erect the superstructure; and consists sometimes of brick or stone alone, but, where necessary, of concrete and stone, or concrete and brick.

The purpose of the foundation is to spread the weight of the structure over a larger bearing surface than would be covered by the structure itself, thus minimizing or preventing unequal settlement. All structures are expected to settle more or less, according to the weight, quality of the work, thickness of the joints, etc.;

but when an unsightly crack appears in a building, it shows clearly that one portion of the structure has settled more than the others, or, in other words, that inequality of settlement has taken place. This may be due to a faulty place in the bottom of the trench; or to a weight being concentrated upon a certain point which has not been properly strengthened to receive it; or, lastly, to the use of two distinct qualities of work, such as gauged brick-work or stone ashlar facings, and ordinary brick-and-mortar backing.

Concrete.—It may be possible that, in some situations, where hard gravel, etc., forms the bottom, concrete is unnecessary, but according to the London Building Act, it is required that concrete at least 9" thick, and extending 4" each way beyond the width of the bottom course of footings, should be used. The depth, however, will depend upon the thickness and height of the wall or structure, the weight to be carried, and the nature of the subsoil. A safe guide, however, is exemplified in Fig. 10. Taking the wall in section, and extending the concrete each side of the bottom course of footings, drop perpendicular lines as outside width of concrete, the depth being determined by an angle of 45° passing from the point **A** of the neat work, and cutting the outside line of concrete.

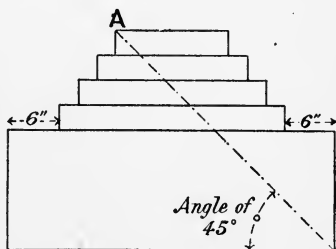

FIG. 10.

The concrete should consist of one part finely ground Portland cement, or blue Lias lime, two of sand, and five or six of gravel, broken brick, or stone. Broken brick or stone small enough to pass through a $1\frac{1}{2}$ " mesh is preferable for the aggregate. A cubic yard of concrete would require 27 cub. feet of broken brick, stone, or shingle, 9 cub. feet of sand, $4\frac{1}{2}$ cub. feet or $3\frac{1}{2}$ bushels of Portland cement, and 25 gallons of water. These quantities should be correctly measured, turned over together three times dry, and again several times while the water, through a rose, is being sprinkled over the mass. It was once considered that concrete should be shot into the trenches from a considerable height, but this has since been proved to be an error, as the heavier particles sinking to the bottom and the lighter floating to the top, prevent the desired formation of one homogeneous mass. The concrete should therefore be gently placed in position to the levels previously

taken, and allowed to become thoroughly set before the brickwork is started.

FOOTINGS.

Footings are always the same, whether they be for English, Flemish, or any other bond. They are built as far as possible as heading courses in elevation, the

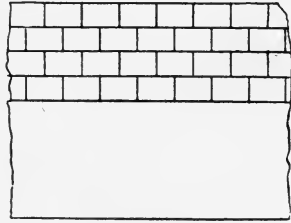
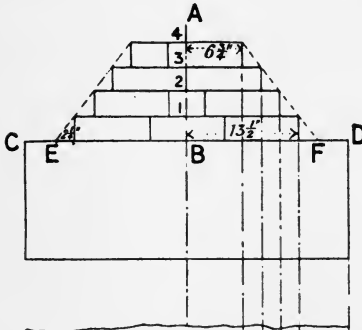
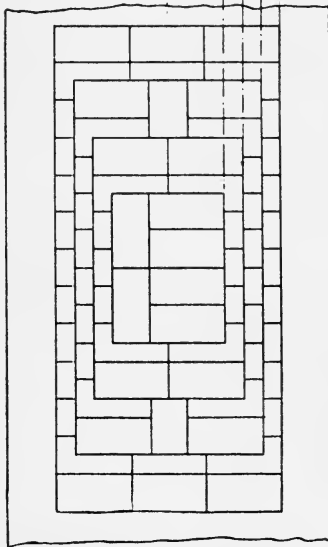

FIG. 13.



Figs. 11 and 12.

rule being that the bottom course of footings shall be twice the thickness of the wall intended to be built, each course losing in thickness half a brick successively, stepping off in offsets of $2\frac{1}{4}$ " on each side until the desired thickness of the wall is attained. As an example, a $1\frac{1}{2}$ -brick wall will have a bottom course of 3 bricks, the next $2\frac{1}{2}$, the next 2, and then the neat work. It is also advisable that walls of 18" and over in thickness should have the bottom course of footings doubled. Thus a 2-brick wall will have the two bottom courses of footings 4 bricks thick.

Students preparing for the various Building Trades Examinations will find the following an easy, accurate, and quick method of drawing plans, elevations, and sections of footings for all thicknesses of walls. Taking the footings for a $1\frac{1}{2}$ -brick wall as an illustration, it being immaterial whether plan, elevation, or section be drawn first, it is convenient

to start with the section, and from this to draw the plan and elevation. According to the rule, it is evident that the footings with one course of the given wall will consist of four courses, viz. 3, $2\frac{1}{2}$, 2, and $1\frac{1}{2}$ bricks. Draw (Fig. 11) centre and base lines **AB** and **CD**; upon the centre line mark up the four 3" courses 1, 2, 3, 4; upon the base-line measure off to the right and left $13\frac{1}{2}$ ", that is, half the width of the bottom course. Beyond this again on each side, for the sake of construction, allow a distance of $2\frac{1}{4}$ ", naming these points **E** and **F**. Through point 4 draw the top of the fourth course $6\frac{3}{4}$ " on each side of the centre line; from each extremity of this line, to points **E** and **F**, draw faint raking lines; proceed through points 1, 2, 3, to draw other horizontal lines, terminating on each side at the raking lines. From the meeting points of the lines 1, 2, 3, 4 with the raking lines, drop perpendiculars to the lines below. Each offset will then be found to be $2\frac{1}{4}$ ". Now fill in each course with 9" stretchers, taking care that whenever a $4\frac{1}{2}$ " header is necessary, it shall, when possible, be placed upon the inside of each course. Clean out the raking lines, and draw in the concrete as already described.

From the section, the plan (Fig. 12) may then be easily drawn below, and the elevation at the side, as in Fig. 13, taking care that stretchers upon section appear as headers upon plan and elevation, and *vice versa*, and that the courses break joint by $2\frac{1}{4}$ ".

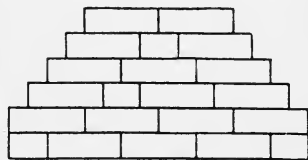

FIG. 14.

Fig. 14 is the section of footings for a 2-brick wall, showing the bottom course doubled. The elevation and plan may be taken from it, as in Figs. 11 and 12.

BONDING.

Bond in brickwork means a tie or link. It is an arrangement having for its object the massing or building of bricks in such a manner as to make them, when so placed or built, act in concert together as a whole. For this purpose no vertical joint of one course should be less than a quarter of a brick from the vertical joint above or below, so that a sharp instrument inserted between two bricks and thrust downward should not be able to penetrate more than the thickness of a brick and a bed joint. This applies

not only to face bond, but internal bonding as well. This equalizes the strength of the bearing surface, and transmits the weight downward from one course to another. When bricks are so placed or built together they are termed walls.

The following are the principal kinds of bond, in their order of importance:—

English bond, by far the strongest, and, in the opinion of many,

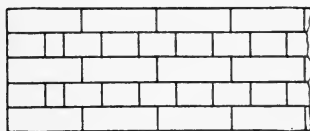

FIG. 15.

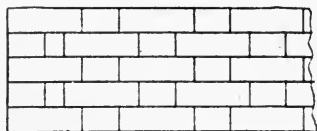

FIG. 16.

the best in appearance, consists of alternate *courses* of headers and stretchers (Fig. 15).

Flemish (double): alternate header and stretcher upon the same course and both sides of the wall (Fig. 16).

Flemish (single): Flemish bond outside with English backing.

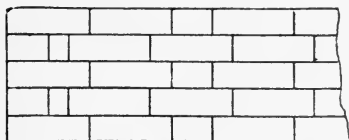

FIG. 17.

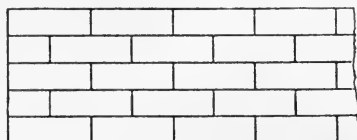

FIG. 18.

Sussex or garden wall: three stretchers and a header alternately upon the same course. Used principally to obtain fair face on both sides of a 9" wall (Fig. 17).

Stretching: stretchers upon each course, for 4½" walls (Fig. 18).

Heading: headers only upon each course for circular corners (Fig. 19).

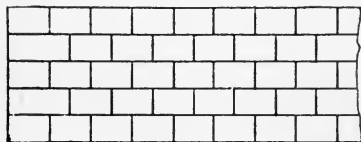

FIG. 19.

Diagonal and herring-bone: as lacing or strengthening courses in thick walls, and also for flooring (Figs. 20 and 21).

Rules for English Bond.—Whenever, in the thickness of a wall, there is an odd half-brick—*e.g.* 1½ brick, 2½ bricks—then, while

laying a heading course on one face, a stretching course should be laid upon the other, the remaining space being filled in with headers laid at right angles with the face-line. In the case of

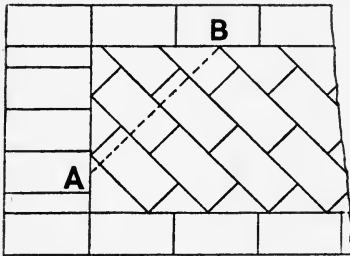

FIG. 20.

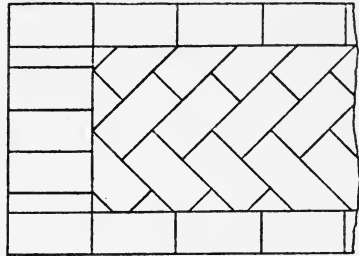
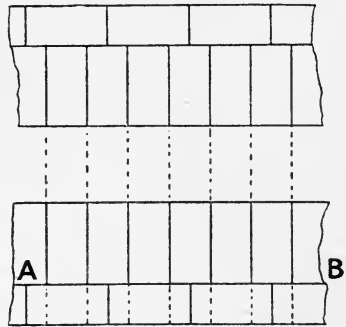

FIG. 21.

quoins, etc., upon the internal angle, the stretcher should quarter-bond with and project $2\frac{1}{4}$ " from the heading course which is at right or any other angle to it.

When a wall is an even multiple of a brick in thickness—*e.g.* 2 bricks, 3 bricks, etc.—then, while a heading course is laid upon one face, a heading course will be laid upon the other; the same applying to the stretching course, the quarter-bonding upon the internal angle being done by means of the header.

Transverse joints should be *unbroken*. There can be no excuse whatever for *broken* transverse joints, the weakness of which is shown in Figs. 22 and 23. Here it will be seen that a good face bond is obtained, but that in the $4\frac{1}{2}$ " between **A** and **B** in the last diagram, the headers are joint upon joint, the strength being diminished almost to that of three $4\frac{1}{2}$ " walls built against each other. This error is often incurred through quarter-bonding, in walls having the odd half-brick in their thickness, upon the internal angle with a header.



FIGS. 22 and 23.

The centre of a header of one course should fall upon the centre of a stretcher in the course above and below.

The closer should always be next the quoin header.

It is only by understanding thoroughly and properly applying

these rules that correct bonding will be arrived at. That which appears to make brick bonding so difficult is want of system. The following is a systematic method to be adopted in drawing plans of alternate courses at the angle of a brick wall built in English bond:—

The $1\frac{1}{2}$ -brick wall (Figs. 24 and 25) will serve as an illustration. Draw the perpendicular lines **AB** and **DE** under one

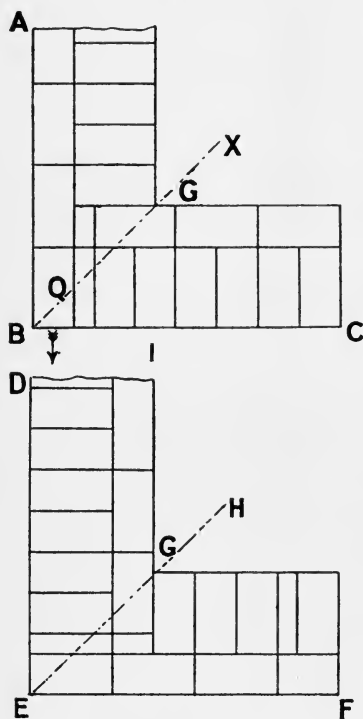

FIGS. 24 and 25.

another, and in the same straight line; from **B** and **E** draw the horizontals **BC** and **EF**. With the angle of 45° from **B** and **E**, draw faint mitre-lines **BX** and **EH**; set off from **B** towards **C** in the point **I** the thickness of the wall, $1\frac{1}{2}$ brick; now with the distance **BI** draw lines parallel to **AB** and **DE** above, but terminating at the mitre-lines. From where these lines meet the mitres, draw horizontal lines beyond **BI**, but parallel to **BC** and **EF**; draw broken lines at the end of each block, and the outline diagrams will be finished. Clean out the mitre-lines. Take it for granted that the quoin header points in the direction of the arrow (Fig. 24); then, measuring out from the inner angle and along the line parallel to **BC**, take a distance of $2\frac{1}{4}$ ", and drop a line

from **G**, meeting with and at right angles to **BC**. This will be termed the *governing* or quarter-bonding line, and the necessity of fixing it cannot be too strongly insisted upon in every case, for upon this line depends the whole success of the bonding. As a heading course is required along **BC**, then a stretching course will appear along **BA**. Set off from **B** a distance of 9" along **BA**, and draw a line parallel to **BC**; then set off from **B** a distance of $4\frac{1}{2}$ " along **BC**, and draw a line parallel to **AB**; and as the quoin header **Q** is already fixed, draw headers right and left of the governing line, filling in the remaining space next the quoin header with a closer,

and taking care that each two headers are backed in immediately behind with a stretcher. Returning along **BA**, fill in with stretchers, backing in each with two headers.

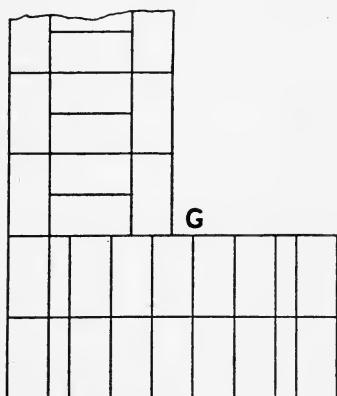

FIG. 26.

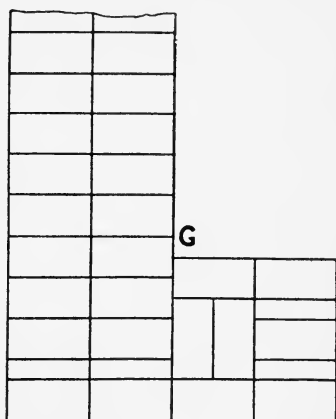

FIG. 27.

The filling in of the bottom block will be a reversal of the top.

As a proof of the bonding, take a tracing of the first course,

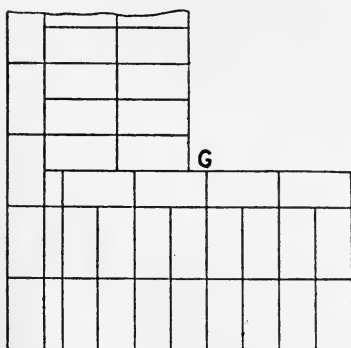

FIG. 28.

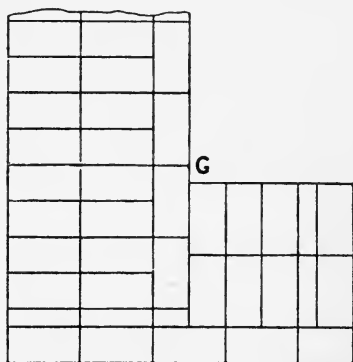

FIG. 29.

and place it over the second, so that the outlines of the blocks coincide; then, if correct, all the joints seen will be $2\frac{1}{4}$ " apart.

Figs. 26 and 27, and Figs. 28, 29, 30, 31, 32, and 33, are plans of alternate courses of 2, $2\frac{1}{2}$, 3, and $3\frac{1}{2}$ -brick walls in the same

bond, with one stopped end, the governing line in each case being marked **G**.

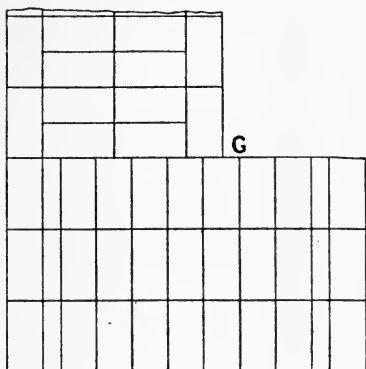

FIG. 30.

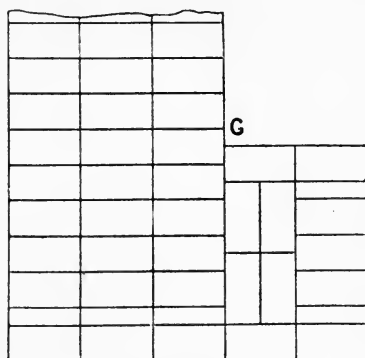

FIG. 31.

Figs. 34, 35, 36, 37, 38, 39, 40, and 41 show the treatment of reveals; **A** in each case being termed the reveal, and **B** the recess. The thickness of wall, depth of reveal, and plan of recess

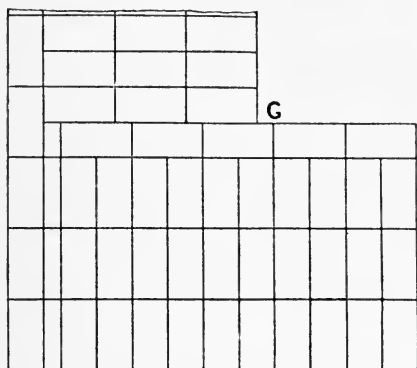

FIG. 32.

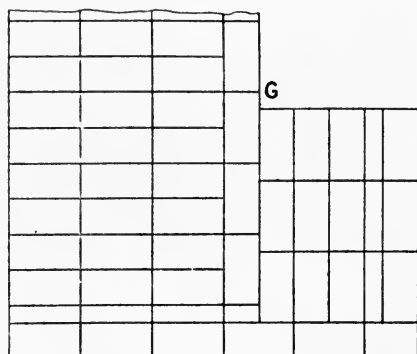

FIG. 33.

will be gathered from the figures: Figs. 36 and 37 are illustrations of splayed jambs; Figs. 42, 43, 44, 45, 46, and 47 are plans of alternate courses of 2, $2\frac{1}{2}$, and 3-brick square piers.

In junctions of walls, as Figs. 48, 49, 50, and 51, there are two rules to bear in mind: First, that the stretching courses of the thicker wall must open to receive $2\frac{1}{4}$ " or the multiple of $2\frac{1}{4}$ "

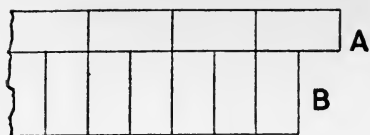

FIG. 34.



FIG. 35.

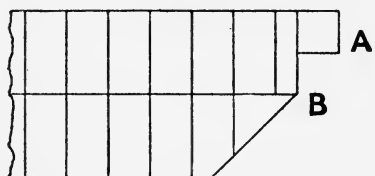

FIG. 36.

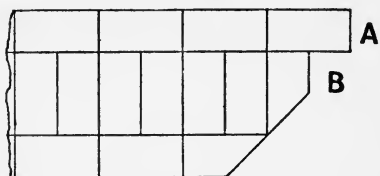

FIG. 37.

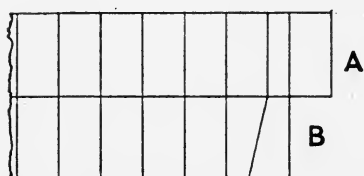

FIG. 38.

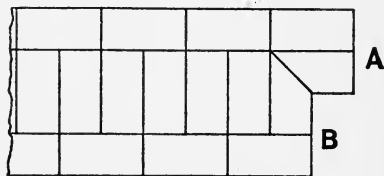

FIG. 39.



FIG. 40.

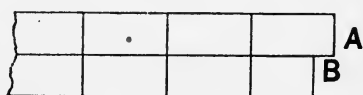

FIG. 41.

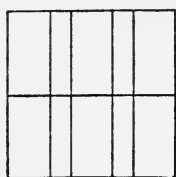

FIG. 42.

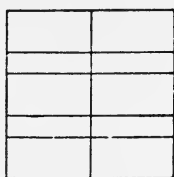

FIG. 43.

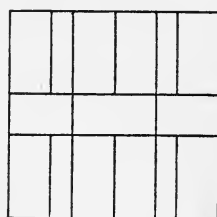

FIG. 44.

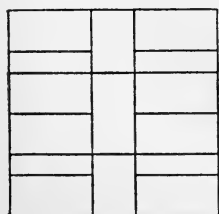

FIG. 45.

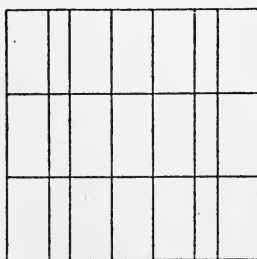

FIG. 46.

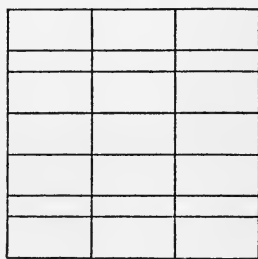

FIG. 47.

of the alternate courses of the thinner wall. When the latter consists of an even multiple of a brick, then it is always the heading course that is let in, and this course will project $2\frac{1}{4}$ " from the major wall. Secondly, that the remaining courses of the minor wall will butt against the heading courses of the thicker wall; the

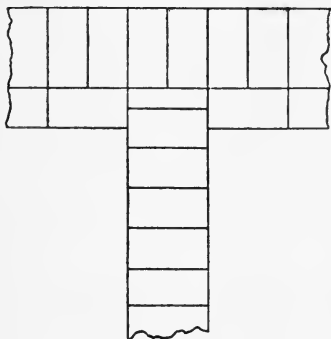

FIG. 48.

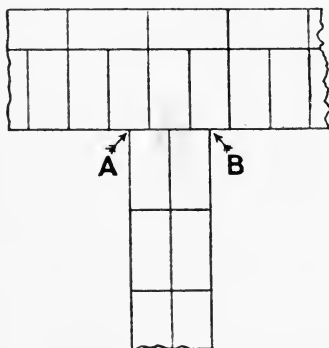

FIG. 49.

centre of one of these headers on each side of the thinner wall coinciding with the wall-line, as in **AB**, Fig. 49. Figs. 52, 53, 54, and 55 illustrate the bonding of obtuse and acute angles. The rules for these will be similar to those for square angles, with

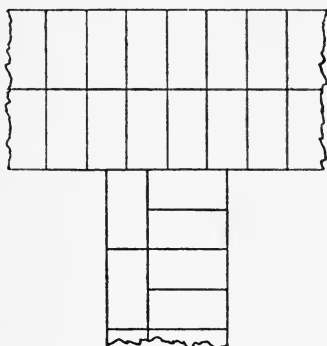

FIG. 50.

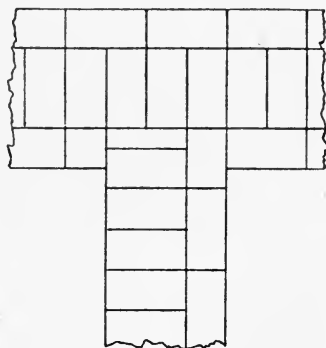

FIG. 51.

the exception that in the obtuse angle a squint brick, **S**, is used for the quoin, and that the internal angle is bonded alternately with a bird's-mouth brick, **B**, and a joint. It will be noticed that the squint brick is $6\frac{3}{4}$ " on the stretching, and $2\frac{1}{4}$ " on the heading face; the $2\frac{1}{4}$ " return being followed immediately by a

closer, thus maintaining $2\frac{1}{4}$ " bond. Again, it would be advisable to make a tracing of one course and place it over the course above or below, to ascertain the correctness of the bond.

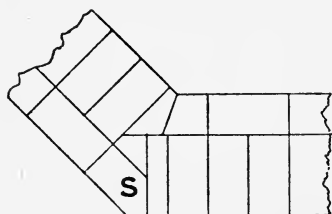

FIG. 52.

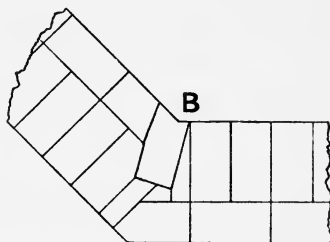

FIG. 53.

Flemish Bond (Double).—This is considered by many to be superior in appearance to English. It is certainly not so strong, and the only advantage that can be brought forward in its favour is that, owing to the want of proper relative proportion between the headers and stretchers of most classes of bricks, the use of the alternate header and stretcher upon the *same* course renders it far easier to keep the perpend than when using *alternate* courses of headers and stretchers. The principles underlying correct bonding

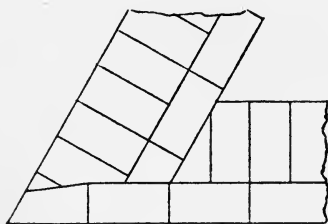

FIG. 54.

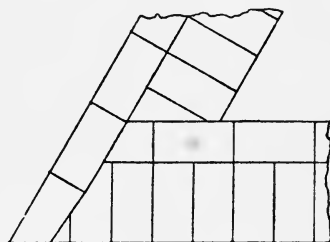

FIG. 55.

in English must, as far as practicable, be applied to Flemish bond, though the rules cannot be adhered to as rigidly as in the former. Thus in the $1\frac{1}{2}$ -brick wall (Figs. 56 and 57) the quarter-bonding stretcher on the internal angle projects $6\frac{3}{4}$ "; this is also the position of the governing line. Again, in the 2-brick wall, while, as in English, the quarter-bonding on the inside angle is obtained by means of a header, for the sake of keeping the transverse joints unbroken, the bat **A** is introduced, corresponding as far as possible with the stretcher **B**. Figs. 56, 57, 58, and 59 are plans of

alternate courses of $1\frac{1}{2}$ and 2-brick walls in double Flemish bond, with one stopped end.

The mode of finishing at **C**, Fig. 59, is strictly Flemish, but for the sake of strength this should be treated as in English bond.

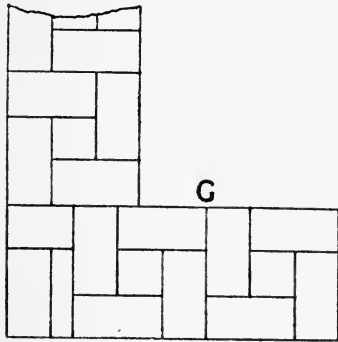

FIG. 56.

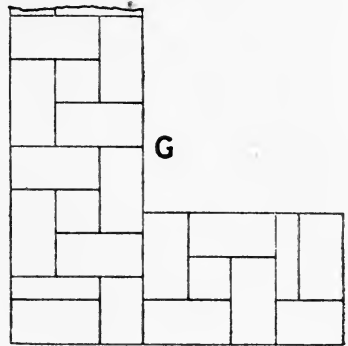

FIG. 57.

If tracing-paper be used, as already advised, it will be seen that there are several instances of joint upon joint, thus proving the inferiority of the bond, in point of strength, to English.

Double Flemish is not used in walls of very great thickness, neither is it often used in cross or junction walls, but the

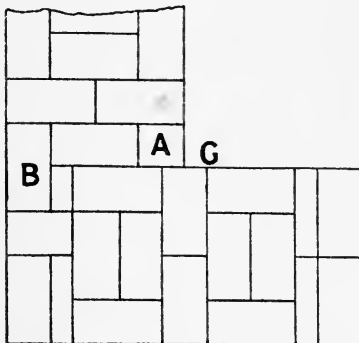

FIG. 58.

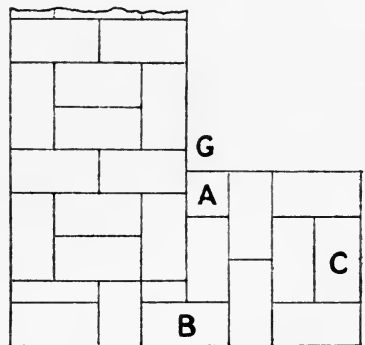

FIG. 59.

example given in Figs. 60 and 61, may occur in practice. Here an 18" wall, English, is intersected by a $1\frac{1}{2}$ -brick wall, double Flemish. The rules given for English bond are again applicable, the only difficulty being to obtain perfect bond between **A** and **B**. This will be overcome by remembering that the centre line drawn

on a header must fall upon a similar centre line upon a stretcher in the course above and below.

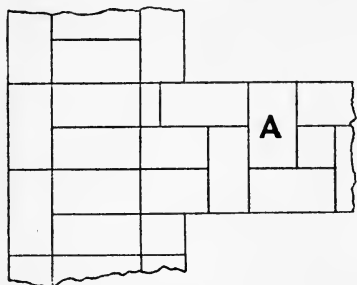

FIG. 60.

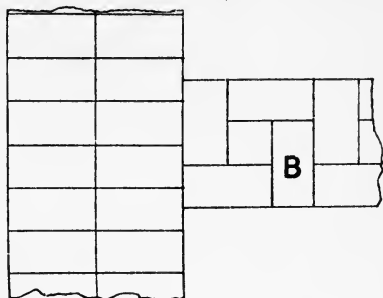

FIG. 61.

Figs. 62 and 63 are plans of alternate courses of a 9" wall with $4\frac{1}{2}$ " reveals and $2\frac{1}{4}$ " recess; Figs. 64 and 65 being similar plans of a $1\frac{1}{2}$ -brick wall with $4\frac{1}{2}$ " reveals and $4\frac{1}{2}$ " recess.

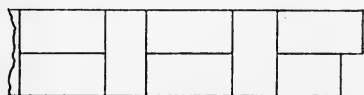

FIG. 62.

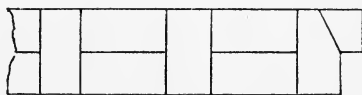

FIG. 63.

In square piers, double Flemish bond, the preceding rules should, as far as possible, be adhered to, the only difficulty occurring in 18" piers. Here, for the sake of strength, it would be

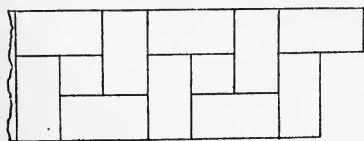

FIG. 64.

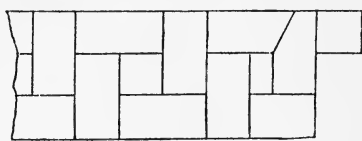

FIG. 65.

better to adopt a bonding as shown in Figs. 66 and 67, or to arrange it exactly as in English bond. The $2\frac{1}{2}$ -brick pier, however (Figs. 68 and 69), will be found to be fairly strong.

Figs. 70, 71, 72, and 73 are examples of acute and obtuse angles very similar in construction to those in English bond.

Single Flemish.—This consists of Flemish bond upon one face, and English bond upon the other. The face work is usually Flemish, and the backing English. In this class of work the only

way to ensure good bond is to treat single Flemish in the same way as English. By doing this, single Flemish bond will be found

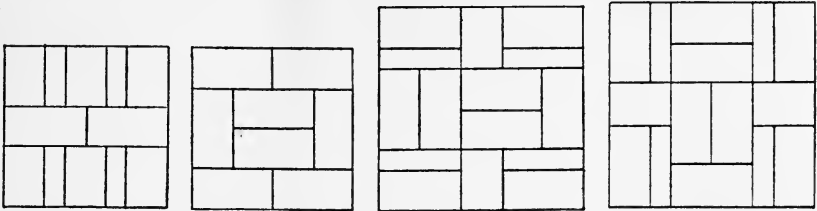

FIG. 66.

FIG. 67.

FIG. 68.

FIG. 69.

to be a very simple matter. For instance, in walls having the odd half-brick in their thickness, while using stretchers upon the inner

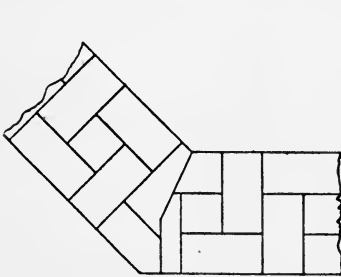

FIG. 70.

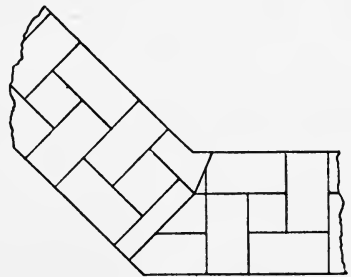

FIG. 71.

face, use as many long headers as possible upon the outer one, and, while laying headers upon the inside, use bats or cropped

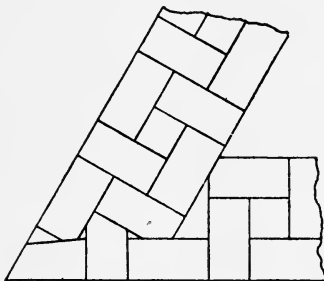

FIG. 72.

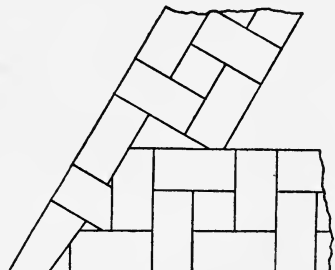

FIG. 73.

headers upon the outside. In walls that are a multiple of a brick in thickness, while using long headers inside, use long headers outside, and the same with the stretchers.

Take the $1\frac{1}{2}$ -brick wall in Figs. 74 and 75 as an example. In the plan **A**, as soon as the governing line **G** is taken through, draw the quoin header parallel to it. Now, if it were English bond, with the exception of the closer, all the face **C** would be

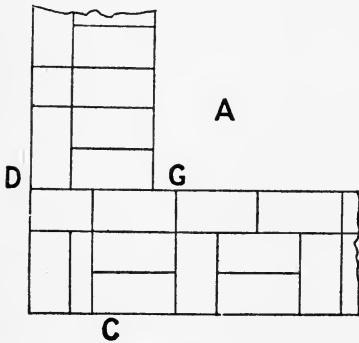

FIG. 74.

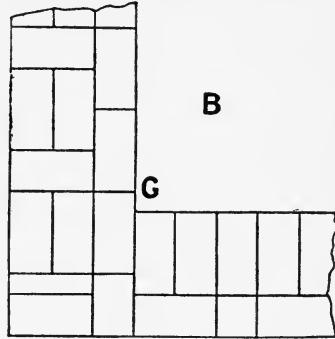

FIG. 75.

filled in with headers, but as it is Flemish on the face, where the stretchers occur, take the headers away and replace them with the latter. Turning to the face **D**, which in English would be a stretching course, wherever, on account of the Flemish face, the

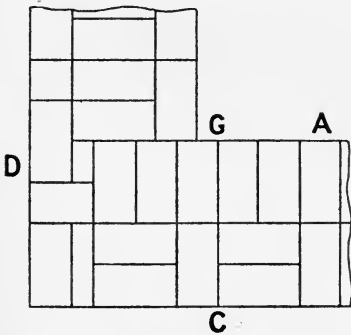

FIG. 76.

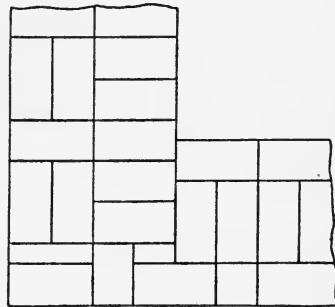

FIG. 77.

headers occur, let them be bat headers, or what might be termed stretchers $4\frac{1}{2}$ " long.

By adopting this method, and applying the rules as far as possible, nearly the strength of the English bond will be acquired. Figs. 76 and 77 are an example of a 2-brick wall in this bond.

Sussex or Garden Wall Bond, as its name implies, is a bond that

should be used for 9" boundary walls only. It is adopted for the purpose of keeping fair face work on both sides, and, as the plans, Figs. 78 and 79, will show, three stretchers and a header are laid alternately upon the same course.

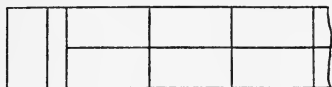

FIG. 78.

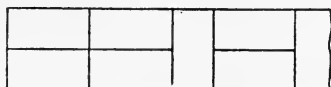

FIG. 79.

English Garden Wall Bond consists of three courses of stretchers and one course of headers laid alternately.

Heading Bond is used when circular corners have to be turned, as in Figs. 80 and 81. It is very evident that stretchers, unless it be upon a large curve, would be too long for this purpose.

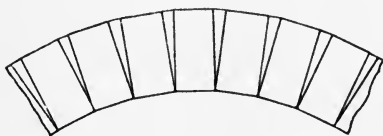

FIG. 80.

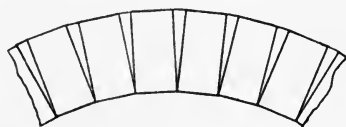

FIG. 81.

Stretching Bond, in which the distance between the cross joints upon one course and the cross joints upon the course above or below is $4\frac{1}{2}$ ", is used for $\frac{1}{2}$ -brick work only (see Figs. 82 and 83).

Diagonal Bond (see Fig. 20).—In this a stretching course is laid at an angle of 45° with the face of, but inside the wall, with

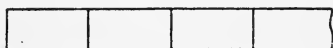

FIG. 82.

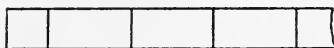

FIG. 83.

the object, it is supposed, of acting as a lacing course, and thus giving greater strength. It can only be used in thick walls; the face bond, whether it be a header or stretcher, still being properly kept. In the next course the diagonal bond would be reversed, as in the dotted line **AB**.

Herring-bone Bond.—This consists of stretchers laid at an angle of 45° from the two faces of the wall towards a centre line (see Fig. 21). It is used for the same purpose as diagonal bond, but really, like the latter, adds but little to the strength of the

wall. As a bond for paving, however, both these bonds are admirably adapted.

DRY AREAS OR AIR-DRAINS.

When the basement of a building is wholly or partly below the ground-line, various devices, such as the construction of dry areas, have to be resorted to for the purpose of keeping the walls free from damp. Dry areas have their disadvantages, in that they become a harbour for vermin, and frequently a receptacle for refuse. It is most important that they should be properly ventilated and drained. A section of a dry area is given in Fig. 84. Another method of protecting the wall is to cover the face of the work with slating, or cement and sand, etc.; but the most effective, perhaps, and that usually adopted, is to cover the face of the wall with a $\frac{3}{4}$ " coating of asphalte.

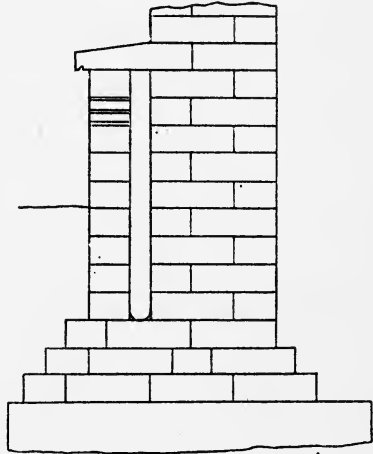

FIG. 84.

HOLLOW WALLS.

These are much used for houses exposed to prevalent winds and rains, the outer wall acting as a shell to protect the inner one. Instead of hollow walls, some people advocate the use of solid brickwork with broken transverse joints, the plea being that its adoption prevents the rain being driven through the wall.

But this is only introducing a greater evil to obviate a lesser one; besides this, the wet will percolate through the bricks themselves. As in dry areas, it must be borne in mind that to make them effective they must be kept thoroughly ventilated and drained, and it is most essential that the tie between the outer and inner walls should be so constructed as not to act as a damp-conveying agent. A good tie is that known as Jennings' patent vitrified bonding brick, made at such a curve that while the inner end is built into a certain course, the outer end is fixed

in the course below (see Fig. 85). These ties are built in across the cavity at horizontal intervals of about 3' and vertical intervals of 12". The objection raised against Jennings' bonding bricks is that, however careful the bricklayer may be to prevent it, mortar,

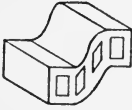

FIG. 85.



FIG. 86.



FIG. 87.

etc., will accumulate on the top, acting as a ready means to carry the damp to the inner wall. Galvanized iron ties of various forms have therefore come much into use (see Figs. 86 and 87). In cavity walls (another name for this class of work), wherever possible, the thinner wall should be upon the outside. Fig. 88

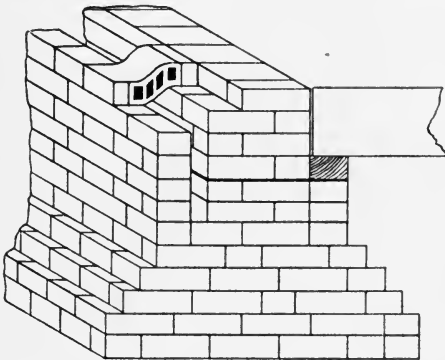

FIG. 88.

is an isometric projection of a 14" wall, 2 $\frac{1}{4}$ " cavity, and 4 $\frac{1}{2}$ " outside work. There are instances, however, where it is preferable that the thinner wall should be inside, as in rubble walls with brick linings. Here it would be impossible to build a 4 $\frac{1}{2}$ " outside rubble, so a 4 $\frac{1}{2}$ " inside brick wall is adopted. There are many disadvantages attached to

hollow walls. The cavity forms a ready resort for vermin; it is also a means of conveying sound; and, unless properly protected, the condensed moisture and rain driven through the 4 $\frac{1}{2}$ " wall keeps the window and door-heads constantly damp, causing them in time to decay. A good method to protect them is to build a strip of lead into the outer wall, and immediately over the frame. The strip of lead should be about 5" wide and 18" longer than the frame, allowing 9" beyond the latter on each side. About 1 $\frac{1}{2}$ " of the width is let into the wall, the other edge being turned up about $\frac{1}{2}$ ", thus forming a kind of gutter. For fear of condensation upon the inner wall, this, a few courses higher, may be served in a similar manner. To ventilate underground floors where

hollow walls are used, the fresh air should be taken direct from the outside, and not from the cavity.

SLEEPER WALLS.

These are dwarf walls used for the purpose of carrying basement floors. They may be $4\frac{1}{2}$ " or 9" in thickness, according to the weight of, and sustained by, the floor, and the height the sleeper walls have to be carried. The walls are built at right angles to the run of the joists, one against each wall of the building, and the others approximately 3' apart the entire length of the room. They are started immediately upon the 6" thickness of concrete (which

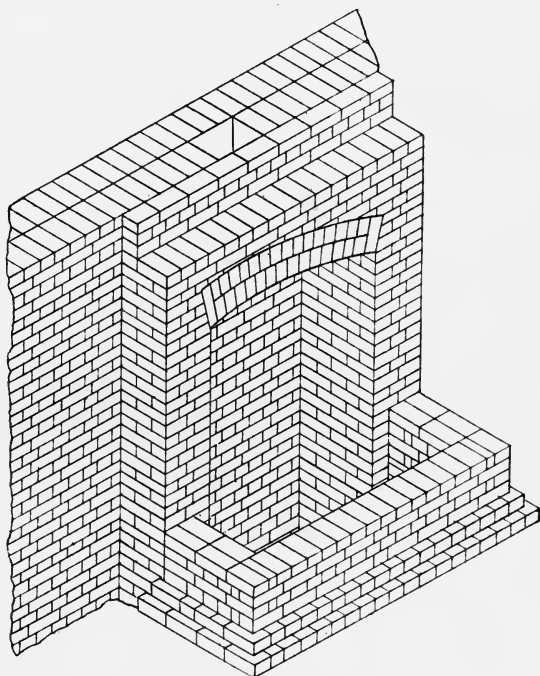

FIG. 89.

should cover the whole of the site), with their proper footings and damp-proof course. At the same time, what is termed a fender is built to enclose the basement fireplace (see Fig. 89), the fender being filled with hard core and concrete ready to receive the front and back hearths. While building the sleeper walls, spaces should be left in them at intervals throughout their length, so as to permit the ready passage of fresh air, the latter

being admitted by means of air-gratings let into the front, back, and flank walls, if possible, of the building. Fig. 90 is the section of a 9" sleeper wall. Where, because of the height, it is impossible to enclose the base-ment fireplace with the fender and fill in as described, then, for large kitcheners where much traffic is likely to take place, an arch is

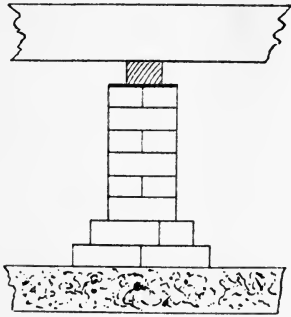

FIG. 90.

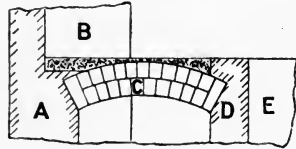

FIG. 91.

turned between the wall and fireplace, as shown in section in Fig. 91, which is taken through the fireplace. Here **A** is the main wall, **B** the breast, **C** the arch, **D** the sleeper or fender wall supported by **E**, a cross sleeper wall.

CHIMNEY BREASTS, FLUES, ETC.

These have to be formed according to the design of the house ; but in most cases, for the sake of economy in space, etc., the fireplaces are built one over the other, from floor to floor, and frequently in party walls, the latter being the wall which divides house from house. The openings will differ in size, according to the range or grate to be used. For example, a full-sized kitchener would require an opening 4' wide and 1' 10½" deep ; the extra depth, beyond what is required for the flue, being lost when the flue is in position by arranging a set-off in the breast to form a mantel-shelf. For an ordinary register stove the opening would be 3' wide by 12" deep, and so on, and, unless provision be made by a breast breaking out upon the outside of a building, a projection or breast must be formed inside the rooms to receive the stoves and provide for the flues. The back of the fireplace should not be less than 9" in thickness, therefore the projection of the breast depends upon the thickness of the main wall and style of stove to be used. That is to say, if the depth of the fireplace be 1' 1½", then in an 18" wall with a 9" back to fireplace, the breast would project 4½" ; in a 14" wall, 9", etc.

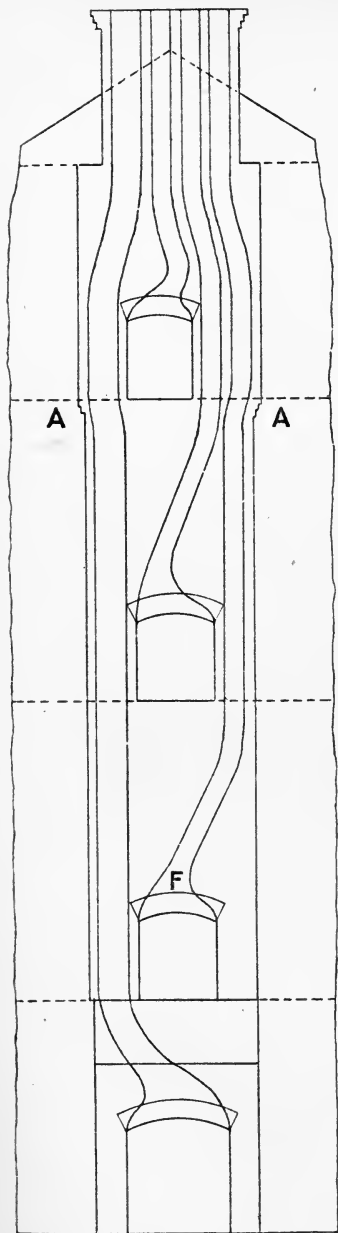

FIG. 92.

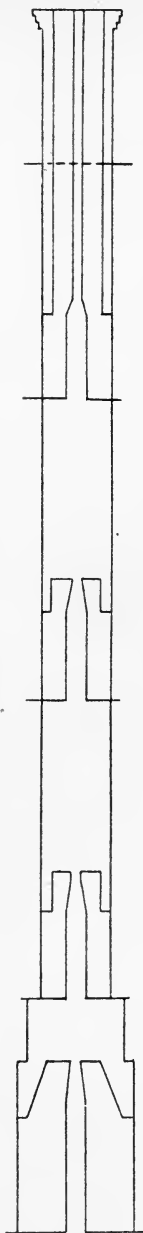

FIG. 93.



FIG. 98.

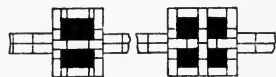

FIG. 97.

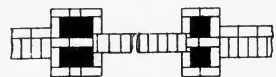

FIG. 96

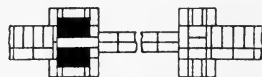

FIG. 95.

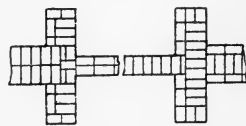

FIG. 94.

It is most desirable to have as much bend as possible in flues ; not to have the flues larger than is necessary (a kitchen flue should be 14" \times 9", an ordinary living-room 9" \times 9"); to gather in quickly above the arch, though not so quickly as to form a nearly flat surface immediately above the fire; and to have perfectly easy bends, with no abrupt angles. For a flue to successfully do its work, smoke should be treated as though it were water. Sharp turns and breaks interrupt the easy flow of the smoke, causing it to eddy round, choke the flue, and return again to the room. The inside should be smoothly rendered with pargetting, *i.e.* cowdung and lime, in the proportion of 3 to 1. This makes a smooth surface, is tough, and is supposed to prevent the smoke-stains and heat from coming through the wall. Ordinary mortar, however, is now more often used than pargetting. Fig. 92 is the sectional elevation of fireplaces over each other, as far as is possible, in a double-breasted wall ; Fig. 93 being a cross-section taken through the double breast ; Figs. 94, 95, 96, and 97 are plans of the same on the basement, ground, first, and second floors ; while Fig. 98 is a plan through the stack.

Chimneys and flues may be constructed at any angle, on condition that any flue inclined at an angle less than 45° is provided with suitable soot-doors.

Mistakes are often made in constructing flues through not carrying them fast enough to the right or left, as the case may be, so as to prepare for the fireplace above ; then, when the mistake is discovered, they are carried over quickly, and a flat surface is formed resulting in a faulty flue. To obviate this, an easy calculation should be made as soon as the flue is gathered over and brought into position above the fireplace. Taking Fig. 92 as an instance, the flue being in position 2' above the arch, measure the height to the fireplace above, and the distance the flue has to be taken to the right or the left, or, in other words, ascertain how many inches it has to be taken laterally to the foot vertically. In the case in point, F is the flue in position in the middle of a 6' 4" breast. The distance to the fireplace above is 6', and the 9" flue has to be carried to the right, allowing 4½" outside work. Then it is evident that the left side of the flue has to be carried a distance of 2' in 6' or 24" in twenty-four courses, to get it into position ; that is to say, the flue must recede on the under side, and sail over on the upper, 1" in every course.

Fireplace Jamb.—When starting the fireplace in the basement,

the jambs on each side will be solid, and are usually 14" on the face by the depth as already described. The flue, being taken either to the right or to the left, will appear upon the next floor as a jamb 18" on the face. This allows $4\frac{1}{2}$ " outside work and a 9" flue. If, however, the flue should be 14" \times 9", then the jamb will be 23" on the face.

As already stated, fireplaces vary from 2' 6" to 4' in width, according to the stove to be used; and they will also vary in height, that for a kitchener being 4', and for an ordinary register 3' high. When the proper height is attained, an iron chimney bar is placed in position. This slightly curved bar (Fig. 99) is 3" wide, $\frac{3}{4}$ " thick, and rests $4\frac{1}{2}$ " each end upon the jambs, the ends also being split and turned half up and half down into the brick-

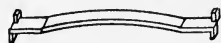

FIG. 99.

work. An arch of two or three half-brick rings is then carried over upon the chimney bar, and the work continued above it (Fig. 100). Instead of the iron bar, lintels of coke breeze and cement, or an arch turned on a temporary turning-piece, is now frequently used (see Fig. 89).

Mode of carrying the Hearth.—The hearth should be at least 18" wide, and extend beyond the fireplace opening 6" each way.

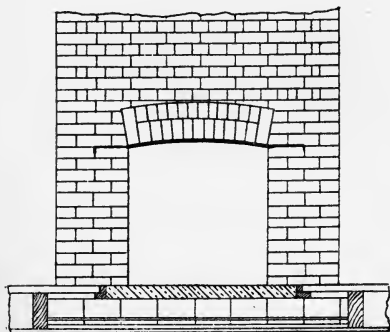

FIG. 100.

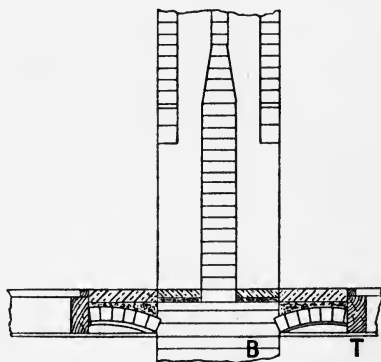

FIG. 101.

There are several methods of supporting the hearth, but the most usual is by means of the trimmer arch. Turning-pieces are fixed in between and at right angles to the trimmer **T** and the breast **B** (Fig. 101), covered with thin lagging seen in section in the last-named figure; the arch, consisting of rows of stretchers on edge and parallel to the breast, is then carried over

and properly keyed in (see Fig. 102), which is a horizontal section taken through the fireplace, and showing the trimmer arch on plan. Another good system is that of tee-irons with the table turned downwards fixed in between the trimmer and breast, sheeted with temporary boarding underneath, and filled in with concrete. Fig. 103 is a longitudinal section taken through such a hearth. Or the tee-irons may be fixed as already described, but kept such a distance apart as to allow a plain tile to be placed in between two adjacent webs lengthwise. Three courses of these tiles should then be laid and properly bonded

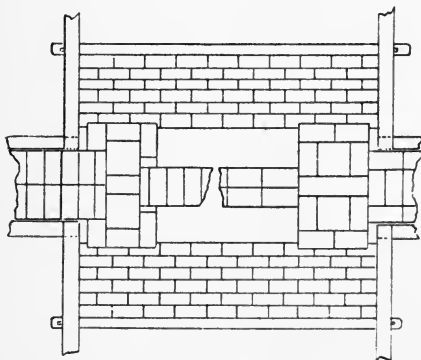

FIG. 102.

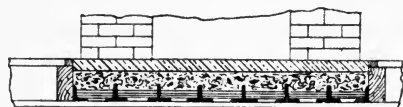

FIG. 103.

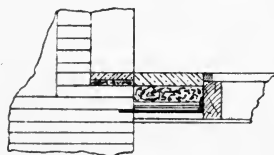

FIG. 104.

in Portland cement and sand. Fig. 104 is a cross-section illustrating the latter system. In each system the surfaces are brought up with concrete to within $\frac{1}{2}$ " of the under side of the hearth, the $\frac{1}{2}$ " being allowed for bedding. The back hearth, when there has been no breast below, will be treated in the same way as the front, but in all other cases will be bedded on the brickwork.

Every flue should be complete in itself, for if openings be left in the $4\frac{1}{2}$ " walls—or withs, as they are termed—which part flue from flue, the smoke will enter the flue not in use, and a down current will take it into the room.

Coring-holes $12'' \times 9''$ should be left, and temporary boards fixed in each flue and upon each floor, for the purpose of clearing out the rubbish that may fall down the flue during the building.

Corbelling.—If it should be necessary to increase the width of the breast, this may be done by corbelling the brickwork between the floor and the ceiling. By sailing over $1\frac{1}{2}''$ per course on each side for three courses, the breast may be increased $9''$ (see

AA, Fig. 92). When anything beyond this is required, then stone corbels should be used. If the fireplace jambs are not carried up from the basement upon solid foundations, but grow out from the party wall as it were by means of corbelling, then the breast may project the thickness of the wall upon which it depends. Hard stone corbels are really more reliable than brick corbelling for this purpose.

When the chimney breast has taken in all the fireplaces and flues required, and appears above the topmost ceiling, the flues are brought into the position in which it is desired they shall be seen when above the roof. This, when out of sight, is done by dropping off the superfluous brickwork in offsets. But when the breast appears as a projection upon the outside of the building, then one method of reducing it is that shown in Fig. 105.

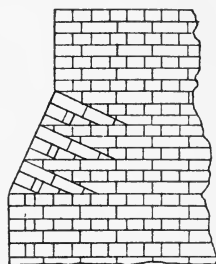

FIG. 105.

Bond in Chimney Stacks.—Though it is far preferable to have 9" outside work to chimney stacks, to keep out both the rain and the cold, which retard the even flow of the smoke, yet it is more often that the outside work is $4\frac{1}{2}$ " only. In bonding stacks, the desired end to be kept in view is that the withs or partings shall be tied in, so as to strengthen what might otherwise be a very weak construction. When the flues are surrounded with 9" work, either English or Flemish bond may be adopted. Figs. 106

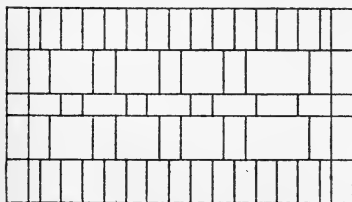

FIG. 106.

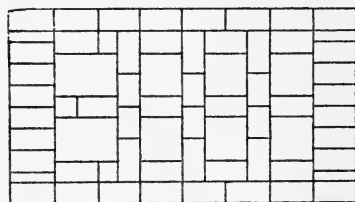

FIG. 107.

and 107 are plans of alternate courses of the first, and Figs. 108 and 109, of the latter. It is with $4\frac{1}{2}$ " work outside that the great difficulty occurs, and up to the present a broken kind of bond, called chimney bond, in which the withs are indifferently tied in, has been used. In this bond a whole stretcher is used upon the quoin; but by sacrificing the small amount, if any, of extra

strength derived from the use of the stretcher upon the quoin, and substituting a three-quarter bat in the stretching course,

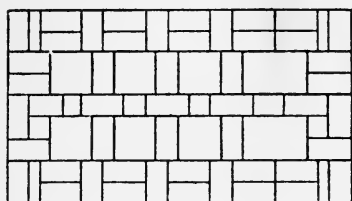

FIG. 108.

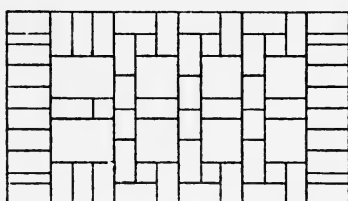

FIG. 109.

instead of using a closer in the heading course, the work may be built either in English or Flemish, and a perfect tie and bond

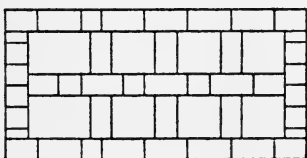

FIG. 110.

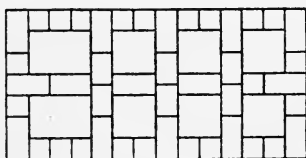

FIG. 111.

be secured. (See Figs. 110 and 111 for plans of alternate courses of English, and Figs. 112 and 113 for the same in Flemish bond.)

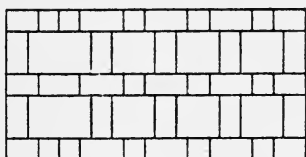

FIG. 112.

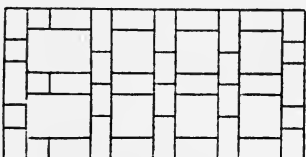

FIG. 113.

According to the London Building Act, every chimney shaft or smoke flue shall be carried up to a height of not less than 3' above the roof, flat, or gutter adjoining thereto, measured at the highest point in the line of junction with such roof, flat, or gutter. And the highest six courses of every chimney stack or shaft shall be built in cement.

SETTING KITCHENERS AND CLOSE FIRE RANGES.

Kitcheners and close fire ranges are many and varied in description; but there are general rules for guidance in setting

them that are applicable to nearly all. Double-oven kitcheners are of course the largest, and the American or self-setting range the smallest. With the latter but little skill is required, while the setting of the former is somewhat difficult.

To proceed to set a kitchener, the first necessary operations are to properly level in a hearth or course of brickwork to take the oven cases; to temporarily place the kitchener in position so as to mark the flues, etc.; and to build in beneath each oven case sufficient brickwork to allow a 2" cavity below the oven. It will be found that the heat from the furnace traverses the top of the oven, and is then induced to descend on the outside or end of the range to the front of the check, which is a piece of sheet iron fixed diagonally on the bottom of the oven, and coming from the back extreme corner to within 4" of the front of the soot door in the face of the bottom of the range, and centrally beneath the oven door. The flue at the end should cover as much surface as possible, and should not exceed 2" wide by the length of the side of the oven, the object being to keep the heated air and gases as close to the oven and over as wide a surface as possible.

It has been described how the flue is formed to the front of the check; it is then allowed to go to the centre of the back at the bottom of the oven, and from that point is taken up in a flue usually 9" or 10" wide and 3" to 4" deep, which ascends vertically to the damper, which is placed at the top of the back coving. The covings are sheets of panelled cast iron that encase the recess above the top plate, the covings, in their turn, being covered with a top plate. They are usually fitted with a plate-rack, and should be bedded with mortar against the insides of the jambs and the brickwork at the back which is formed between the flues.

The boiler is set on a benching of fire-brick built at the back of the ash-pan, and is usually arranged with a flue from the bottom of the furnace to the back of the range, and a vertical flue formed in a similar manner to the oven flue up to a damper placed at the top of the back coving. The boiler, which should be of wrought iron, is drilled and tapped for the connecting of the hot-water circulation.

These are general methods, but special kitcheners often require different treatment. In every case there should be no sharp turns in the flues, and the top flues should be carried above the dampers in the direction of the chimney flue above.

Register, Mantel Register, and Interior Stoves.—The main

object in fixing these is to fill up with brickwork the space which, in the fireplace opening, is not occupied by the stove or flue. In some cases the register is placed in position, and set by filling in the brickwork through the register flap which forms the entrance to the flue for the smoke. These are often insufficiently filled up, thereby leaving a large cold-air space at the top, which causes the smoke to be checked and sent back into the room, instead of pursuing its proper course up the flue.

For interior grates with fire-lump backs, the shape of the back of the lump should be marked out upon the hearth, and brickwork built up to the shape, allowing for a mortar bed at the back of the lump. Here, again, it is important that the opening should be filled up as much as possible, leaving only the size of the flue.

Coppers.—These are usually of galvanized cast iron (see Fig. 114), but sometimes of sheet copper (see Fig. 115), the shape being almost the same, but differing slightly at the bottom. They are



FIG. 114.



FIG. 115.

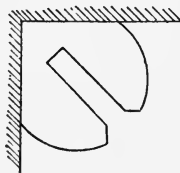

FIG. 116.

usually fixed in an internal angle, the outside being formed into a curve concentric with the copper, and about 8" larger than its radius measured at the top inside the flat rim.

Brickwork is built up to this curve to a height of 9", the recess being formed at the same time for the ash-pit. The furnace bottom is bedded upon this brickwork, the ash-pit being formed as in the sketch (Fig. 116), to a depth from the face equal to the length of the furnace bed, the front of the latter resting 4" to 6" in, from the face of the outside work. Two courses of fire-bricks are bedded on each side of the furnace, and the door-frame is built in; the width of the latter is the same as the furnace, generally 9". The copper is now bedded in position and the flue taken round it, rising at the same time so as to pass over the furnace door, thence round to the back and into the vertical flue prepared for it, into which is inserted a damper to regulate the draught. The object to keep in view in building the flue is to apply the heat to as large a surface as possible, at the same time keeping it close to the

copper. The covering-in of the flue needs great care, and should be done with whole bricks reduced to the required length (Fig. 117).

BROKEN BOND.

In setting out the front of a building or any similar piece of work, rods, having the piers, windows, and door openings marked out upon them, should be prepared. The bond of the quoins, piers, or any feature likely to go throughout the height of the building, must then be set out. The remaining portions coming below and above window-openings and into recesses, etc., may not be in length the even multiple of a brick, in which cases broken bond

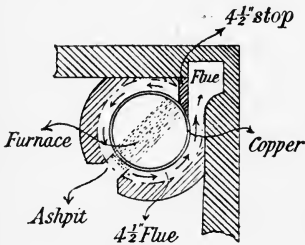

FIG. 117.

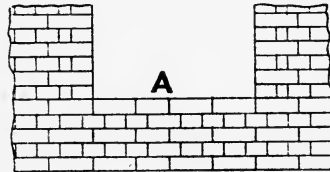

FIG. 118.

becomes unavoidable. This consists either of a bat in the stretching course only; or of a three-quarter bat both in the stretching and heading courses, as **A**, Fig. 118; or, finally, of a three-quarter and a bat in the stretching course and of a three-quarter in the heading course. This broken bond must be kept in the same position with relation to the courses from the start to the finish of the building.

Battering or Retaining Walls.—It is not necessary, in this elementary work, to explain the scientific principles of battering or retaining walls; but a few hints as to their construction, etc., may be of value. The thickness of the work at the base of the wall should not be less than a quarter the vertical height, while the batter should be one-sixth of the latter. The concrete and footings should be put in at right angles to the inclination. For the purpose of keeping the battering wall true, the inclination given—say 6" in 5'—should be added by means of a slip of wood measuring 6" at the top and planed off to a knife-edge at the bottom, fixed to the side of the plumb rule by means of which the plumbing is intended to be done. Lastly, any cross wall going

into the battering wall must be carefully watched, the bond being properly kept throughout the bulk of the cross wall, the latter being made out as necessity occurs at the junction of the two walls (see Fig. 119).

ADDITIONS TO OLD WORK.

When building new work into old, it should be taken into consideration that the old work has already settled, while the new has yet to do so. The method, therefore, of cutting an ordinary toothing, as though the connection were between new work only, is most inadvisable. Instead of this, a clean chase

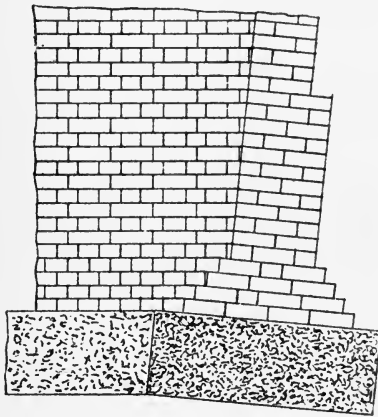

FIG. 119.

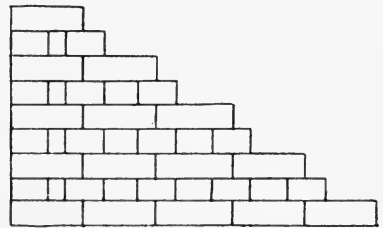

FIG. 120.

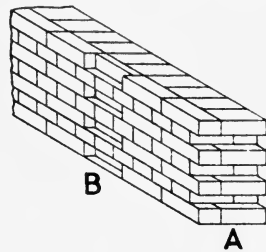

FIG. 121.

should be cut in the old work, into which the new should be carried, leaving the latter free to settle without ugly cracks.

TOOTHINGS.

These should be avoided, if possible, as they are a source of weakness, racking back, as Fig. 120, being preferable. There are two kinds of toothings—those at the quoin of a building, where the wall in which they occur is to be continued (see **A**, Fig. 121); and the indent toothing, left for the connection of a wall at right or some other angle (see **B**, in the same figure).

HOOP-IRON BOND.

Tarred and sanded hoop-iron built in the bed joint throughout the length of the wall, one length for every $4\frac{1}{2}$ " in thickness of the latter, adds greatly to the strength.

PLINTHS.

The plinth is an architectural feature only in the building, and is frequently a source of weakness. The slight projection, often only $2\frac{1}{4}$ " or under, does not conduce to good bonding, and leads to bad workmanship. Fig. 122 is a section showing the best treatment of a plinth projecting $2\frac{1}{4}$ ", with its footings. It will be

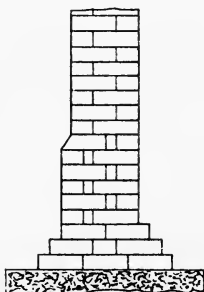

FIG. 122.

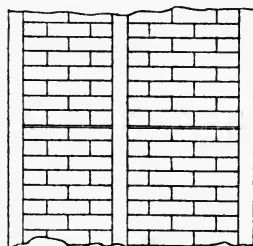

FIG. 123.

seen that the footings are set out for a $1\frac{1}{2}$ -brick wall, one of the offsets being used to counteract the $2\frac{1}{4}$ " projection of the plinth.

BRICK-NOGGING.

This is used in what are termed brick-nogged partitions. These are partitions composed of studs from 18" to 3' apart in the clear, and filled in between with either brick flat or brick on edge (see Fig. 123).

DAMP-PROOF COURSES.

A damp-proof course is used to prevent the moisture of the soil rising up the brickwork. As soon as the work has reached a height of 6" or 9" above the ground level, the top of it should be covered with some damp-resisting material. That most usually

adopted is a layer of asphalt $\frac{1}{2}$ " thick; lead, though expensive, is a perfect damp-proof course. Two or three courses of slates laid in Portland cement, with the joints properly broken, is often used; and, lastly, glazed pottery ware has been found most effective.

LACING COURSES.

In walls built of material in which it is impossible to get a bond, *e.g.* flint, etc., two or three courses of brickwork are frequently introduced to act as a tie or bond; these are termed lacing courses. Again, in big arches, consisting of $4\frac{1}{2}$ "-brick rings, lacing courses are sometimes used to give additional strength (see Fig. 124).

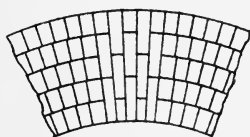

FIG. 124.

FLUSHING, GROUTING, AND LARRYING UP.

Flushing up, as it is termed, consists of filling in every interstice in each course with the mortar used for laying the bricks, and is preferable to grouting, which is the practice of pouring mortar, in a semi-liquid state, into the joints; the water in the latter case evaporates, still leaving cavities in the work. In gauged arches, however, and similar work in which the joints are very thin, grouting is alone practicable. Larrying is used in heavy engineering work only, such as railway abutments, etc. In this case the outside courses of the work are laid with solid joints; mortar is then tipped from a barrow on to the work, spread evenly by means of a larry, and the bricks pushed (forming a solid joint) into position.

JOINTING.

This may be divided into two kinds—natural, which consists of finishing the joint with the mortar in which the bricks are laid; and artificial, or pointing, in which the original mortar is raked out to a depth of about $\frac{3}{4}$ ", and the joint filled in with specially prepared fine stopping or mortar.

Jointing may be finished in various ways. The ordinary struck joint (see Fig. 125). This joint has often been condemned, because of the probability of the rain resting on the slight ledging that it forms, thus rendering the face of the work

damp. The reason for striking the joint in this manner is that, the top edge of the brick being laid to the line, the bottom edge of the course is irregular, and the joint covering this irregularity secures a better appearance when looking up at the work. Fig. 126

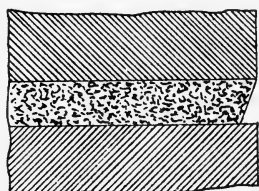

FIG. 125.

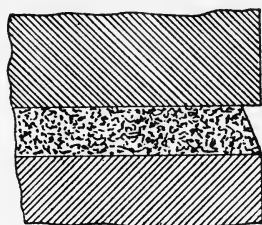

FIG. 126.

is an example of the best method of struck or weathered joint. Fig. 127 is flat jointing, and Fig. 128 flat joint jointed. Fig. 129 is a gauged-work joint, which consists of lime run to a liquid state with water, and strained through a fine sieve; the joint

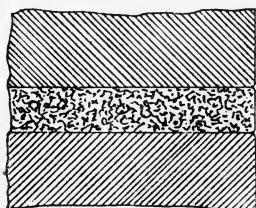

FIG. 127.

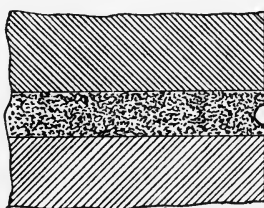

FIG. 128.

should be $\frac{1}{32}$ " only in thickness, hence the sieve should be at least 400 to the square inch.

Pointing.—Tuck pointing is the method of filling in the raked joint with specially prepared stopping, making an indentation in

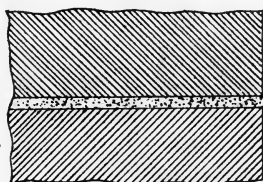

FIG. 129.

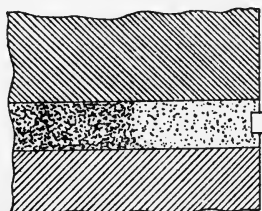

FIG. 130.

it with the tool called a jointer, and with the same tool inserting a white or black putty joint about $\frac{1}{8}$ " wide, and cutting off both edges to a rule with a frenchman, which is a knife pointed and turned up at the end. Fig. 130 is an illustration of this joint.

Bastard Tuck.—This joint is filled in with specially prepared mortar, and finished and made to project in the same material with a thick-bladed jointer (Fig. 131). In this joint, again, the ragged edges are cut off with a frenchman.

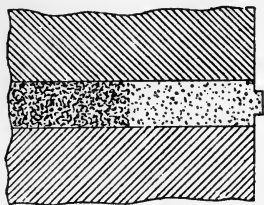

FIG. 131.

Weather joints and flat joints, etc., are very similar to the struck joints, with the exception that the joints are put in after the work is finished, and with specially prepared mortar.

Struck joint is far stronger than pointing, but the latter gives an opportunity of cleaning down the work after the building is finished, thus securing a uniform appearance throughout.

HOUSE DRAINAGE.

If the drain be of stoneware, then the pipes should be of the best London make, truly cylindrical, straight and smooth, tested with the hydraulic test, and joined with Portland cement of the best description thoroughly cooled.

All drains, if practicable, should be outside the house, laid in a true line from point to point, with a fall of not less than 1' 0" in 60' 0". The most suitable for a soil drain is between 1' 0" in 40' 0" and 1' 0" in 60' 0". In drains that have too great a fall, the water travels so rapidly that it is often not of sufficient depth to float the solids and such-like matter to the outfall. Drains with too little fall, however, are liable to silt up, owing to the sluggish flow of water through them.

In laying the drain, it will be found convenient to set each pipe on bricks arranged on a 3" concrete foundation, to the proper fall. The spigot end of one pipe, being first chipped to form a key for the cement, is then placed in the flange of its fellow, the pipes being made to fit by packing up on the bricks, so as to ensure an even-flowing surface upon the inside of the drain. The joints should be made in Portland cement properly and thoroughly trowelled. The drain-pipes are laid on bricks to enable the joint to be easily made, and that the joint may be seen when the drain is being tested. Concrete should then be carefully placed under and around the whole of the drain to a thickness of 6" in all, the top being rounded off to form what might be termed a concrete arch, thus relieving the drain of all weight of earth, etc.

The manholes, or inspection chambers, and disconnecting chambers are most reliable when built of hard stock bricks in Portland cement, and rendered inside to a very smooth trowelled face with Portland cement and sand. Fig. 132 is a plan, and Fig. 133 a longitudinal section, of a disconnecting chamber. A good arrangement for bonding the brick-work, so as to make the chamber water-tight, is to build two $4\frac{1}{2}$ " walls, one backed in by the other, and both their bed and cross joints breaking joint with each other. (See Figs. 132 and 133 for plan and section of the bond.) In the latter it will be seen that one of the $4\frac{1}{2}$ " walls starts and finishes up with a half-course. There is no tie between the two $4\frac{1}{2}$ " walls, and the strength will depend upon the mortar; but the work, having been thoroughly flushed up, will be found to form a most effective chamber.

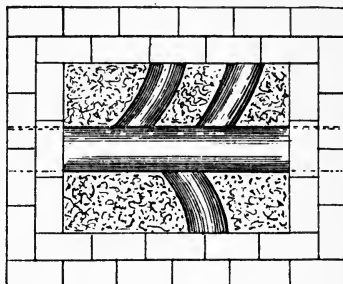

FIG. 132.

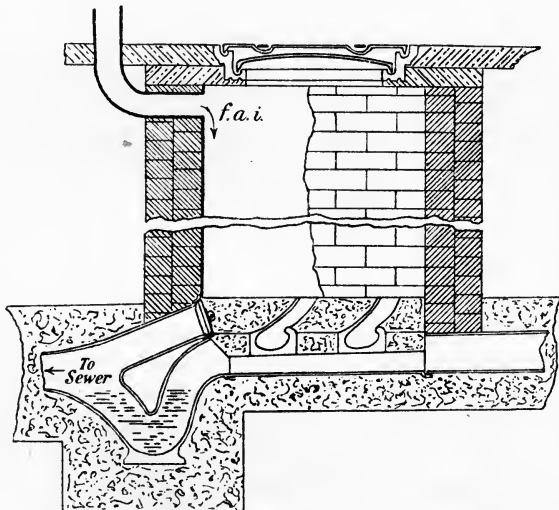

FIG. 133.

It is very necessary that all drains should be easy of access, and so arranged as to be readily swept from end to end, and that the trap in the disconnecting chamber should have a sweeping eye.

A plunger, or brush, the full size of the drain should be passed through, to see that no obstruction from cement is projecting upon the inside of the pipes. The drains should also be easy of inspection throughout, from manhole to manhole, and disconnected from the public sewer by a properly constructed disconnecting trap (see Fig. 134).



FIG. 134.

The principal feature of a disconnecting trap is that it should be self-cleansing, having a water-seal of at least $2\frac{1}{2}$ " and 3" or 4" drop from the bottom of the channel to the surface of

the water in the trap. A 6" trap of this description should not hold more than one gallon of water when at rest. An inlet for fresh air should also be provided in the disconnecting chamber.

Each house should have a separate drain to the public sewer, all branches being connected in the direction of the flow by means of manholes; but it may here be remarked that manholes inside the house are objectionable.

The main inspecting and disconnecting chambers must have curved channels to the branches, and all the extreme ends of the drains should be ventilated with lead pipes.

It is important that a lead pipe, and not an iron or rain-water pipe, be used for this purpose, because the moisture in the drain air causes the iron to oxidize, flake off, and form a deposit, which, when there is no water to wash it away, would in course of time choke the air-passage. The soil-pipe frequently serves as a ventilating pipe. These ventilating pipes must be taken their full size to the highest point of the roof, away from chimneys, windows, and other openings which would admit the sewer-gases into the house, and protected with copper-wire guards.

Rain-water and waste pipes must be intercepted from the drains with a properly constructed trap. This will be, in the ordinary course, kept supplied with water from baths, etc. This trap should also have a good water-seal, and be self-cleansing, the inlet connection entering the trap above the water-line, under the grating, and at an angle of about 45° . Traps not frequently supplied with water are liable to lose their seal by evaporation.

Where practicable, the intercepting trap from bath waste should

enter the drain beyond the discharge from the soil, so that it may be utilized for flushing the drains. Where this cannot be done, it is advisable to use an automatic flushing tank, so that the drains may be flushed at least once in twenty-four hours.

The waste from the scullery sink should also be intercepted from the drain by means of a grease-trap, this also being flushed with an automatic flushing tank, which breaks up the grease and rushes it away through the drain.

At the completion of the work, everything connected with the system of drainage should be tested—the drains, by means of the hydraulic or water test; and the soil and waste pipes and fittings, by the smoke machine.

With respect to iron drains, a practical sanitary engineer, who is also a silver medallist and freeman of the Plumbers' Company, writes as follows:—

“For a terrace house, where the whole of the drains have to be fixed inside, I should recommend heavy cast-iron drains, coated inside and out with Dr. Angus Smith's solution for the prevention of rust. The joints to be properly made with yarn, backed up with molten lead, and well caulked. In fact, I am strongly in favour of iron drains for every position, for when once made sound they will remain so for many years, which is not the case with stoneware drains. I have seen stoneware drains that have been properly laid, embedded in cement concrete, standing the hydraulic test year after year, and then for some unknown reason becoming thoroughly defective. But I have never found this the case with iron drains. Some will say that iron drains so quickly rust away, but I have not found it so where the pipes have been properly coated and covered with cement concrete.

“A short time ago I had to make some alterations to an iron drain laid twelve years ago, and found, in breaking it, that the coating of black was in perfect preservation, showing that a very thin coating of sewage and hardness from the water protected the black inside, and the covering of cement concrete the outside. An advantage would be gained by fixing a few expansion joints to an iron system of drainage, say to every chamber, to allow for expansion and contraction. If these joints are fixed in the chamber, the packing to the joints can be easily renewed.

“The by-laws of the various vestrys, etc., require that all soil and ventilating pipes be fixed outside the house; but I see no reason why they should not be fixed inside, and yet make a better

job. There are several arguments in the favour of fixing inside : the pipes are out of the way of frost and the different temperatures of the outside atmosphere ; the warmth of the house rarefies the air inside the pipes, which causes a better up-current ; and it saves damaging the house by cutting through the walls for the various branches. There is no reason, if the pipes are fixed inside, why they should be hidden ; a good plan is to provide a chase plastered and finished in Parian cement, then to fix the pipes and leave them exposed ; the chase and pipes may be painted to match the existing work."



PART II

GAUGED WORK, ARCHES, ARCH-CUTTING, ETC.

GAUGED work consists in rubbing and cutting to any required shape specially made bricks, or "rubbers," as they are technically termed.

This class of work is usually done in what is called a cutting shed, provided with a bench about 2' 3" high and 2' 6" wide.

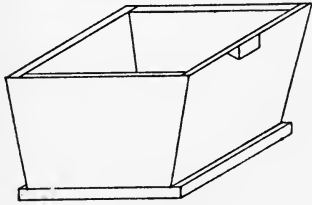

FIG. 135.

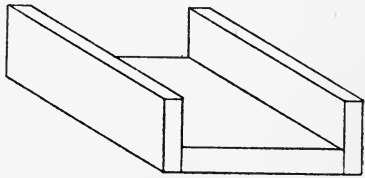

FIG. 136.

The tools and appliances required are a rubbing stone (Park Spring, for preference), circular in shape, and 14" diameter; a bow saw fitted with twisted annealed wire No. 18 gauge, parallel file 16" long, small tin scribing saw, square, bevel, straight pieces of gas

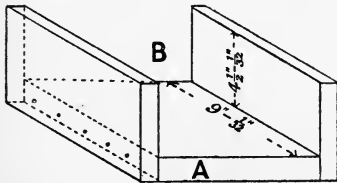

FIG. 137.

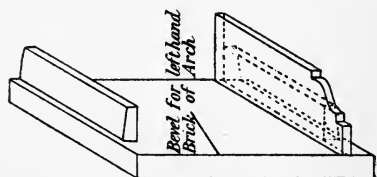

FIG. 138.

barrel for hollows in mouldings, etc., bedding slate to try the work for accuracy, straight-edges, compass, setting trowel, putty box (Fig. 135), boaster, club hammer, and scotch (the three latter for axed work), reducing boxes for thickness (Fig. 136) and for length

(Fig. 137), moulding boxes (Fig. 138), boxes with radial sides for obtaining the wedge-shape voussoir according to the template (Fig. 139), a setting-out board about 6' 0" × 5' 0", and lining paper 2' 6" wide, etc.

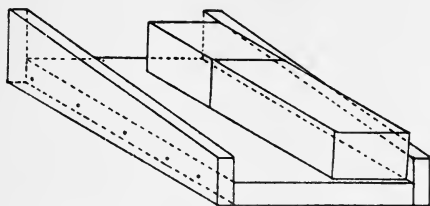

FIG. 139.

The most elementary kind of gauged work is that which is known as plain ashlar, consisting of heading and stretching courses for plain facing. The operations are as follows: First bed the brick, *i.e.* place the brick with the letter or hollow side on the rubbing stone; then, holding the brick with both hands, rub it upon the stone, giving it a circular motion from right to left, and trying it occasionally with a straight-edge till the bed of the brick has become a perfect plane.

Next, with the rubbed bed turned from the body, place the side or face of the brick upon the stone, and rub as before, at the same time endeavouring to make the side square with the bed, testing it by application of the square, stock to the side, and the blade to the bed of the brick. Then serve the head in the same way, making it square with both bed and face. After these operations are perfect, the brick has to be reduced to thickness; this is done by placing it on its bed in a reducing box (Fig. 136), the measurement of the inside depth of which is $\frac{1}{32}$ " under 3", sawing off the superfluous material and finishing with a file.

If for a stretcher, next place the brick face downwards in a 9" lengthening box (Fig. 137), making the square end to coincide with the front edge **A** of the box, and saw off to length, finishing with a file at the back edge **B**. The cut stretcher will be 9" less $\frac{1}{32}$ " in length.

In preparing long headers, the bricks would have to be placed in the same box, face downwards, but the saw and file would be used along the top edge of the box, thus making the header $4\frac{1}{2}$ " less $\frac{1}{32}$ " in width.

If for bat headers, then the squared end is placed downwards in the box, and saw and file used along the top edge again.

Arches.—These may be plain, axed, or gauged.

In plain or rough arches the bricks are not cut at all, the joints alone give the radiation, and the arch is usually made up of rings.

The Relieving Arch.—The relieving or discharging arch (Fig. 140), as its name implies, is used for the purpose of relieving the weight from any portion of the building which is too weak to bear it, and discharging or transmitting it to piers, etc., specially prepared to receive the load. They are sometimes used in the face of buildings, when they are also treated as ornamental features.

The most frequent use for the relieving arch is inside the building, over door and window openings. The opening is first bridged by the lintel, which should rest not less than $4\frac{1}{2}$ " upon the jambs each side of the opening; next a brick core is built throughout the entire length of the lintel to serve as a turning piece for the arch; the curve being obtained by means of a curved mould having the same rise it is

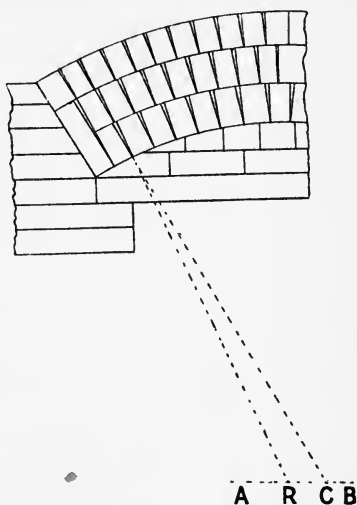

FIG. 140.

intended to give the arch. This is applied to the face of the core; the bricks are marked, and then cut to shape. A skewback, which should radiate from the striking point, is built at each end of the lintel; and the arch, consisting of $4\frac{1}{2}$ " brick rings, but starting with a stretcher at each end upon the skewback, is then turned over the core. When a flat rise only is given, the brick core is done away with, and the curve is worked upon the lintel.

It must not be forgotten that the lintel is in length the exact span of the arch; that the object of the lintel is for the purpose of fixing the joinery; that the core acts only as a turning piece for the arch, and to fill up the space between this and the lintel; and that neither of them influences the strength of the discharging arch in any way. Should a fire occur, the lintel would burn and the core fall, but the arch ought to remain intact. The method of striking out the arch will be the same as that given for the segment.

When arranging the rings, those starting from the top and working downwards alternately should always have a key-brick; the other rings will key in with a joint. As already stated, in this as in all other rough arches, the bricks themselves are square, and the radiation is obtained by means of the joint. The mode of

drawing the radial joint is as follows: Prick over the 3" courses, and fill in the face from the radial point **R**, as in the semi-arch (p. 50). Through the radial point, and parallel with the lintel, draw an indefinite line **AB**; make one of the courses or bricks of the arch parallel, by keeping the *top* equal to the *bottom* of the brick; produce the line which does this so that it cuts the line **AB**, in **C**, then **C** will be the point by means of which a line drawn from it through the soffit end of the face joint of each course will give the radial joint. This method must be followed each side of the arch.

The Invert Arch.—It often occurs that the principal loads in buildings, such as girders carrying the floors, etc., are concentrated upon certain points, as piers, for instance, which are usually strengthened to receive them. Should there be openings upon each or one side only of the pier, it is very evident that the weight of the pier and its load would be taken vertically downward to one part of the footings only, little able, perhaps, to bear it.

To relieve the special part of some of the weight, by spreading it over a larger area of footings, invert arches are used,

as in Fig. 141. Here some of the weight is taken from

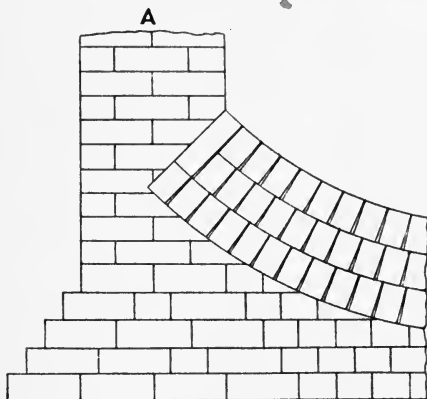

FIG. 141.

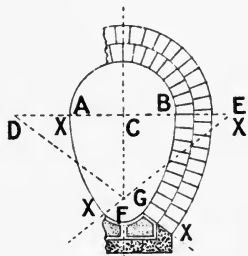

FIG. 142.

the pier **A** and its fellow, and transmitted by the invert arch to the footings in between them. It will be noticed that the lines from the radial point to the skewbacks form an angle of 45° , this being found to be the best angle to receive the weight.

Chimney breasts in basement stories are often treated in this way.

Egg-shaped Sewer (Fig. 142).—This sewer, as its name indicates, is shaped like an egg, with the smaller end downwards,

this shape being found the best adapted for a varied charge of sewage. It matters little whether it be during a time of storm water, or during a dry season when there is but a small quantity of sewage, there is always a sufficient depth of matter to ensure a perfect flow. The sewer may consist of two or three $4\frac{1}{2}$ " rings of brickwork, with a terra-cotta or hard-brick invert, bedded in concrete. The mode of setting it out is as follows: Let **AB** be the diameter of the head, or crown, then **CB** will be the radius, and **C** the radial point; measuring out from the centre **C** to the left and right of **A** and **B**, a distance equal to **AB**, will give the radial points **D** and **E**, from which the curves of the sides may be described; then, for the invert, draw from the point **C** at right angles to **AB** a line **CF** equal to **AB**. By dividing **CF** into four parts, the radial point **G** will be found. The termination of the sides x, x and the beginning of the invert is determined by lines passing from **D** and **E** through **G**. The $4\frac{1}{2}$ " rings will be arranged as in the relieving arch, the outer rings having the key-bricks, one at the crown, the line **FC** passing through the centre; and what might be termed two keys, one on each side, the line **DE** passing through their centres; the next ring towards the inside having straight joints at these points; the next inner ring, keys, and so on.

Axed Arches.—Axed arches are really roughly cut gauged arches with a $\frac{3}{16}$ " mortar, instead of a $\frac{1}{32}$ " putty joint. Therefore the mode of obtaining the template and the system adopted for gauged arches generally, applies equally well to axed ones: the only difference being that when the bricks are hard, the brick will have to be scribed each side to the template and across the soffit with a tin scribing saw, and cut off to the scribed lines with a boaster (sometimes called bolster) and club hammer upon the banker, and the remaining material between the scribed and boastered lines neatly axed off with a scotch (sometimes termed scutch).

In arches in which the end or soffit may not be cut to a bevel, such as glazed bricks and blue Staffordshires, etc., the mode of applying the template to the face of the brick is somewhat different. It would simplify the matter, perhaps, if, after the template was obtained, as described on p. 50, the bottom of the template were to be cut off to the cutting mark, and made to fit the soffit line of the drawing of the arch and then applied to the face of the brick, the brick and template both being on end, and both the bed and back of the brick cut off to the template. That is to say, both

edges of the template would be cutting edges (see Fig. 143, which shows the template in position for cutting the brick).

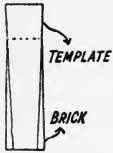

FIG. 143.

Gauged Arches.—Throughout this work one principle is adopted for setting out and obtaining the templates for all gauged arches, and by careful attention to the instructions given, all practical men should be able to gain a perfect mastery of the subject. Whenever the

compass is mentioned, it will be understood that in full-size work the radius rod would be used, and although, when describing the construction, the whole of the arch is alluded to, a half only is drawn, as would be the case when setting out in practice.

The Semicircular Arch.—This arch is known always as the semi (Fig. 144), the opening here being 3' 0", the face 9", and the soffit $4\frac{1}{2}$ ".

Construction, etc.—Draw an indefinite base line; upon and perpendicular to it erect a centre line; upon the base line set out the opening **AB**, half each side of the centre line; then with the point of the compass at the centre **C**, and the pencil at **B**, describe the larger half of the soffit or intrados, and with the point still at **C**, but the pencil extended 9" beyond **B**, describe the outer line or extrados. In most rubber bricks the brick and joint together will hold out or measure 3". Therefore take a distance of 3" in the dividers, and starting with half the distance each side of the centre line on the extrados, prick over till the courses come home exactly to the springing line, increasing or decreasing the distance taken in the dividers, *i.e.* making it slightly over or under 3"; but always taking care that the first pricking, or key-brick, shall be equally divided half each side of the centre line. Call these first two prickings **D** and **E**. From the centre **C**, through **D** and **E**, draw the approximate key, but producing the line through **E** to **H**. This approximate key will also be the shape of the trial template.

To obtain the template the following pieces are necessary: Two small straight-edges $16" \times 2" \times \frac{1}{2}"$, and also a piece of board $14" \times 3\frac{1}{4}" \times \frac{1}{2}"$, with both sides planed and one edge shot square and true. Place the latter, which may be termed **F** (Fig. 144), with the shot edge against the line radiating from **C** to **D**, and with a long straight-edge having the end of one edge against the radial point **C**, and the other end coinciding with the produced line **H**, and laying over **F**, mark the latter the shape required. Having cut and shot the template to the line drawn upon it

and square with the face (when it will appear as **F**, Fig. 145), proceed to traverse it; *i.e.* seeing that in pricking over there are fourteen courses in half the arch, including the key; ascertain whether fourteen such templates will exactly fill half of the arch, starting with the key and terminating with its edge upon the springing line. The way to traverse the template is as follows: Place the template upon the approximate key, taking care that it exactly fits it; draw a pencil

line, which will be known as the filling-in mark, across the left-hand edge of the template, and immediately over the soffit line. Next place the two straight-edges **O** and **X** one upon each side of and tight up to the template, always keeping **O** a little above the filling-in mark (see Fig. 145). Keep **X** firmly in its place, remove the template, slide **O** against **X**, remove **X**, place the template against **O**, with the filling-in mark on the soffit line; place **X** against it, remove the template, slide **O** against **X**; and repeating this movement till the right-hand edge of the template comes out to the springing line. Should the template at the last turn be parallel to the springing line, but not quite home to it, bring the template down a little by placing the filling-in mark higher up. The top may come over the springing line, and the bottom reach or not quite reach home; then a shaving or two must be taken off the top, or, if the bottom comes over, then a few shavings off this. Each time it becomes necessary to alter the filling-in mark or the template itself, it will be necessary to traverse again, taking care always at the start that the template is equally divided, half each side of the centre line. When the

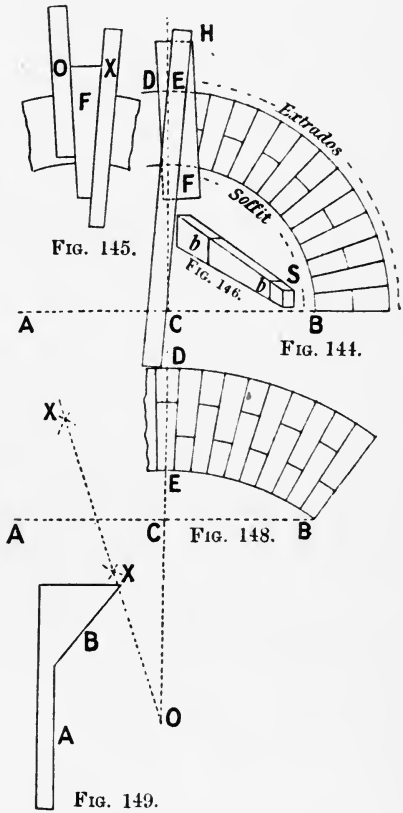

When the

template has been obtained, line in the joints of the arch with it. The next important matter is to allow for joint. This is done by placing the edge of the template against the radial line **CD**, backing it up with the straight-edge **O** kept firmly in position, then, by sliding the template up against the latter, it will recede from the radial line **CE**. If for axed work, the template may be worked up till it leaves the radial line **CE** by $\frac{3}{16}$ " ; if for gauged work, by $\frac{1}{32}$ " ; then in a similar way to that in which it was marked for filling in, scribe for cutting mark immediately over the soffit line (see **S**, Fig. 146). When for gauged work, to prove that the amount allowed for the joint is correct, traverse the template again, with the *cutting* mark on the soffit line, for four courses, when, if it leaves the fourth line by $\frac{1}{8}$ " , it may be taken as correct. In this arch the lengths of all the courses are alike, and may be taken on the edge of the template, bearing the cutting mark ; this edge being termed the cutting side of the template, and the other the bed, coinciding in this respect with the arch-brick itself. Place the bed of the template against the radial **E**, with the cutting mark upon the soffit line, then on the cutting side make a mark on the edge immediately over the extrados (these marks should always be squared across). While the template is in this position, the bottom and top bevels **B** may also be obtained, by making similar squared lines on the bed of the template, and then connecting these on the face, as Fig. 146.

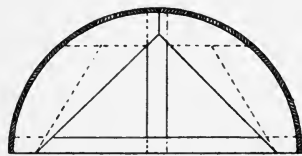

FIG. 147.

In using the template, the soffit bevel will be taken off by placing the blade of the bevel, or shift stock, against the bed of the template, the blade pointing towards the soffit and agreeing with the line upon the face of the template. It is advisable to write the size of the opening, the name of the arch, and the number of courses upon the template, and also to apply the centre (Fig. 147), upon which the arch will be turned, to the striking out, ticking off the courses upon it, and squaring them through ; this will act as a guide to keep the proper thickness of joint when setting the work. The setting out should be on lining paper, which may be saved for future reference.

How to cut a Semi-arch.—Bed the brick and square the face (see p. 46) ; square the head from the face, but bevel it from the bed, the stock being placed against the bed, and the blade to

the head. These bricks must be prepared for right and left hand, that is to say, with the face of the brick turned towards the body, half the beds should point towards the right and half towards the left. Then prepare a radiating box 10" wide in the clear, and rather longer than the template, the sides of which, worked from a square line across the bottom, radiate exactly as the template (see Fig. 139), also having the cutting mark upon each side exactly opposite each other. Great care must be taken that the box is accurate, and it is advisable to try the first radiated brick upon the bedding slate, with the original template. Two bricks, right and left hand, may be placed in the radiating box, with their faces to the sides and their soffits to the cutting marks, and sawn close to the top edges of the sides of the box (the latter being protected with tin), and finished with the file, taking care to file away from the front arrise or side of the box, so that the former may be perfectly sharp; then, in a lengthening box (Fig. 137), face downwards, and with the soffit placed tight against a straight-edge held across the end, cut off to a length of 9".

If the arch is more than 9" on the face, then, before radiating the course must be made up in length. Taking an arch 12" deep on the face, as an instance, and dealing with a course having a stretcher towards the soffit, the stretcher will be cut off 8" in length, and the opposite bevel obtained in the lengthening box. A bat over 4" in length, bedded, faced, and bevelled, will be fitted to the top of this, the template applied, the brick scribed to the length on the cutting side and to the square mark on the bed, the two marks on the brick connected by the scribing saw, and sawn off square with the face. By this means the course is cut off to length, and the top bevel obtained at the same time.

It may here be noted that the 9" lengthening box can be used for any odd measurements, by nailing a stop or fillet across the bottom of the box and parallel to one squared end, according to the length required, the worked end of the brick being placed against the stop, and the piece not required cut off to the end of the box.

For an arch having a 9" soffit, it will be readily understood that a face stretcher would have to be taken to a depth of $4\frac{1}{2}$ " in a reducing box and backed up with a properly squared and bevelled bat, and that for a soffit stretcher the brick would be bedded, the face bevelled for the soffit, and the header, acting as the face, squared from the bed and soffit. By placing this brick

soffit downwards in a reducing box $4\frac{1}{2}$ " deep, the opposite bevel, after sawing, would be worked upon it; being afterwards made out, on the face, by a bedded, squared, and bevelled bat, and cut off to length, to the template.

Every arch should be keyed in with a stretcher towards the soffit; and it will be found that, counting the courses in half the arch, and including the key, if there be an odd number, then there will be a stretcher for the start or upon the skewback, and a stretcher for the key; if an even number, then a header for the start, and a stretcher for the key.

Arch with Moulded Soffit.—In arches with moulded soffits, although the end in view, with respect to bevells, etc., is the same, the mode of working is somewhat different. The section of the mould required must be cut upon two boards, $10" \times 4\frac{1}{2}" \times \frac{1}{2}"$, screwed together, the edges shot and squared, and the moulding cut upon them while thus fixed, so that they shall be exactly similar; the edges representing the face and soffit may be protected by tin, and they should be fastened one on each side, exactly opposite each other, to a box having a stout bottom and two sides only, and being about $10"$ in the clear after the moulds are fixed (Fig. 138) the bricks being properly bedded and roughly squared upon the side which is not intended to be the face. The bevel is taken from the template in the usual manner, and marked upon the bottom of the box, both right and left, with the back of the stock against the front edge of the box and the hind part of the blade on the bottom; the roughly squared edge of the brick between the roughly squared face and the bed is fixed against the line or lines thus marked (if there be room, two bricks at a time may be cut, one for right hand and one for left); the saw is taken through the moulded soffit and the top face, and then with file, barrel, etc., the brick is finished, being bevelled, moulded, and faced at the same time. When the brick is taken out of the box, should the soffit, or face, be not quite true, the bed is rubbed to fit *them*, the square and bevel being used for this purpose. The remaining operations are the same as in plain-gauged arches.

Setting.—The centre (Fig. 147) having been fixed with folding wedges beneath it, so as to make it easy of careful removal after the arch is set, should be tested for accuracy.

Axed arches are set in fine mortar, the joint being either struck, or raked out and afterwards pointed, to give it a fancied resemblance to gauged work. Gauged arches and gauged work

generally are set in lime putty, as already described (p. 39). The putty is served to the setter in a putty tub. This is a box open at the top and with bevelled sides, being about 15" × 12" at the top, but smaller at the bottom, and about 9" deep (see Fig. 135). The setter, keeping the putty frequently stirred, and having knocked and brushed the dust off the brick, holds it lightly on the top of the putty, takes up just sufficient to form the joint, removes a small quantity from the centre, makes the joint true at the edges, puts the brick in position, and lightly taps it to make it solid. Arches are started from the right and left hand, and worked up towards the key, which is put in last. When the arch is completed in its place, it is grouted in with Portland cement, a joggle having been formed in the brick by cutting a groove 1" × $\frac{1}{4}$ " in the middle of it; this grouting in with Portland cement greatly strengthens the arch. In years past, a bead was formed with the joint, and the work left. But now, any irregularity in the face, mouldings, etc., is corrected by means of files, pieces of barrel, brick, handstone, etc., both brick and joint being left flush and brushed down with a soft brush.

The Segment Arch (Fig. 148, p. 51).—Opening, 3' 0"; rise, 6"; face, 12". Draw an indefinite base line, and at right angles to it above and below draw an indefinite centre line. Upon the base line set out the opening **AB**, half each side of the centre line **CD**, and above the base line measure off the 6" rise in **E**; then, with the point of the compasses at **A**, and taking any distance greater than the half of **AE**, describe arcs above and below the base line; with the same distance in the compasses and the point at **E**, cut these arcs in **X**. Then a line being drawn through these intersections and meeting the centre line, will give the radial point **O**.

With the point of the compasses at **O**, and the pencil extended to **A**, describe the soffit, passing through **E** and terminating at **B**. Next, with the straight-edge at **O** and passing through **A**, draw the skewback or abutment, and the same with **B**; then measure up from the soffit upon the centre line 12", and with the point of the compasses at **O**, and the pencil extended to the 12", draw the extrados terminating at the skewbacks. Now proceed as in the semi to procure the template, with this exception, that the work terminates on the skewback, and not on the springing line. Having procured the template, fill in the arch. The courses will be divided into 8" stretchers and 4" headers, taking care to key

in with an 8" stretcher towards the soffit. This arch having a skewback, care should be exercised that this is properly cut and set, especially if it be in ordinary building bricks. A mould or gun, as it is termed, should be taken off the drawing and applied to the reveal; the projecting or triangular portion answering to the fall of the skewback (see Fig. 149, p. 51). Here **A** being placed against the reveal, the skewback is built up to **B**.

In this, as also in the semi-arch, if the student wishes to draw the arch only, then the extrados may be pricked over at 3" as already described, and the face joints filled in from the radial point by means of a straight-edge passing from it to the divisions on the extrados.

Moulded Segment.—When a moulding is worked upon the reveal and continued round the soffit of the segment, a new difficulty presents itself

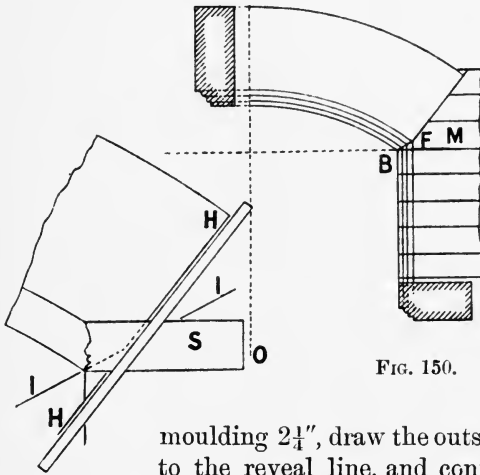

FIG. 150.

in the intersection of the mouldings between these two. Again, take a 3' 0" opening, 6" rise, 12" face, with a $2\frac{1}{4}$ " moulding, the half being shown (Fig. 150). Set out the soffit and reveal as in the plain gauged segment; then to the right of the reveal line measure off the depth of the

moulding $2\frac{1}{4}$ ", draw the outside moulding line parallel to the reveal line, and continue above the base line. Then on the centre line and above the soffit again measure off the $2\frac{1}{4}$ " moulding, and with the point

of the compasses at **O** and the pencil extended to the $2\frac{1}{4}$ ", describe the moulding line parallel to the soffit, and meeting the reveal moulding in point **F**. From the point **F** to **B** draw a line. This will be the mitre line. The skewback will be taken, as before, from the point **O**, but will begin at the point **F**. The arch will be cut precisely in the same way as the moulded semi, with a slight addition to the top course of the moulded reveal and the first course of the arch, *i.e.* where the intersection takes place. Two pieces of board, $10" \times 3" \times \frac{1}{2}"$, should be planed and shot while

FIG. 151.

screwed together, so that they shall be perfectly true in themselves and to each other; the lines **H** and **I** will be produced each way, and the moulds laid to coincide with the brick **S**, Fig. 151; then by means of the straight-edge, which is made to coincide with the produced lines as shown, the lines **H** and **I** will be accurately drawn upon the moulds. They should then be cut to this shape, and are known as shoe moulds. A moulded brick being placed on its bed in between two shoe moulds can, by means of the saw and file, be properly mitred as **M**, Fig. 150; the moulded end of No. 1 course of the arch should be then cut to tightly fit it. All other operations for the moulded segment will be the same as in the moulded semi.

In axed arches with field-moulded bricks (bricks having the moulding cast upon them in the brick-mould while in the green state, and afterwards burnt), such as bull-nosed and mop-staff beaded, the treatment of the mitre will be nearly the same, only, that instead of the mitre being solid, as in **M**, Fig. 150, the portion **BF** in the latter figure will be cut upon the top of the brick, and the skewback taken from that (Fig. 152).

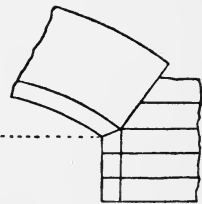

FIG. 152.

Camber Arch.—This is sometimes called a straight arch; but it has really a slight rise, the rule being to give the soffit a rise of $\frac{1}{8}$ " for every foot of opening. The reason for giving the rise is to counteract the optical illusion which causes the arch, if straight upon the soffit, to appear to sag, or camber, the wrong way. When a slight rise is given, the arch appears to be straight upon the soffit. It would be impossible to strike such a slight sweep with a radius rod; the rise is therefore given by means of the camber slip. A camber slip should be made of good hard wood that will not shrink or twist; mahogany or oak is excellent for this purpose. It is always convenient to keep one in stock, and if it be long enough it will answer for any opening. There are not many camber arches over 7' 0", therefore a convenient length for the camber slip would be about 8' 0". The mode of obtaining the camber slip is as follows (an extreme case is given, as being easier of illustration): Suppose the opening to be 3' 0", and the rise 1" to the foot, then the camber slip 3' 0" long would have a rise of 3"; take a rod 3' 0" long, measuring in width 1" at each end and in the middle $2\frac{1}{2}$ ", or, in other words, having in the

centre half the required rise; shoot this piece from the middle to the two ends perfectly straight, thus forming two triangles, as it were, upon a common base; call the centre **B**, and the two outside points **A** and **C** (see Fig. 153). Then take a piece of board a little over 3' 0" long and 6½" wide by ½" thick, planed both sides, and one edge shot, draw a centre line upon the face of

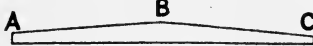

FIG. 153.

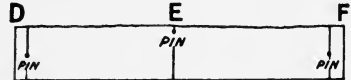

FIG. 154.

it, and 18" each side of it draw two other lines; call the centre line **E**, and the two outside lines **D** and **F** (Fig. 154). Upon the centre **E**, 6" up from the shot edge, drive in a pin, and upon **D** and **F**, 3" up from the shot edge, drive in other pins. Then take the first piece (Fig. 153), already prepared, and with a pencil held at the centre **B**, apply it to pin **F**; and with **A** on

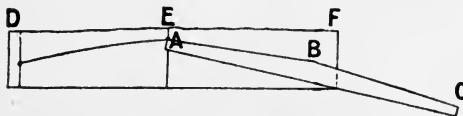

FIG. 155.

the same piece pressed against the pin **E**, move the piece with the pencil from **F** to **E**, describing half the curve (Fig. 155); repeat this process on the other side, moving the centre **B** with the pencil from **D** to **E**, and the curve will be drawn; then cut the curved side to the line drawn, and the camber slip will be completed. To prove the camber slip, lay it down and mark all round it, then reverse it, and if the camber slip coincides with the lines drawn by it, it will be correct. In using the camber slip always work from a centre line.

The next consideration is what amount of skewback should be given to the camber arch. By the old system the opening was taken as a radius and a line cut upon the centre line as a radial point for the skewback; but this has been found to give too great a skewback, and becomes a source of weakness. The proof of this is as follows: First considered as a wedge, sustaining a vertical thrust or load. If a wedge were made too flat, when driven home the ends would become bruised and split. Again, let it be supposed that the camber arch is taken out of the segment, or let it be considered that behind each camber there is an invisible segment; then, as far as strength is concerned, the more of the segment contained in the camber, the stronger the arch; experience shows that

the longer the radius, the less the rise, or the flatter the segment, and hence the more of it in the camber. The less acute skewback, if produced to meet a centre line, will give the desired longer radius. Therefore a good datum to work to, as a general rule, is to give each skewback 1" fall for every foot of opening, when the arch is a foot upon the face.

To set out the Arch.—Opening, 3' 0"; face, 14" (Fig. 156). Draw the usual base line, with a centre line perpendicular to it; set out the opening **AB**, half each side of the centre line **CF**. Then, with the centre of the camber slip upon the centre line, and the edge just coming out at the points **A** and **B**, draw the camber or curved line.

Then to obtain the skewback. At **A** and **B** erect faint perpendiculars, and upon these lines measure, from the base line upwards, distances of 12" and 14"; take square lines to the left of **A** and right of **B**, and upon these lines at the 12" height measure off 3", the allowance for an arch 12" face and 3' 0" opening; then from **A** and **B**, through the outer points of the 3" lines, draw the skewbacks indefinitely. These skewbacks would answer for any depth of face for this size opening. Now take a point upon the centre line, 14" up from the base line, place the centre of the camber slip upon this point, the curved edge at the same time passing through the two 14" points upon the perpendiculars erected at **A** and **B**, and while in this position draw the outer or extrados line. Prick over the courses upon this line, as in other arches, starting with the key and working out to the skewback. If it were possible to produce the skewback downwards to meet the centre line, then this point might be treated as the radius point wherewith to fill in the approximate key. But should this not be practicable, the number of courses taken upon the extrados line, by reducing the distance taken in the dividers, will have to be pricked over on the intrados line, taking care, at the same time, to have an equal proportion on each side of the centre line. Having pricked over the top and bottom lines accurately, draw in the approximate key, but producing the line to the right of the centre line, both above and below the arch. Call this produced line **DE**. Now, to procure the approximate template; as before, prepare a piece of $\frac{1}{2}$ " board, $3\frac{1}{4}$ " wide and 18" long, both sides planed and one edge shot. Let the shot edge be exactly placed against the left-hand line forming the key, and, with a long straight-edge placed over the board, the edge coinciding with the produced line

DE, mark the template. Cut and shoot it accurately, and traverse as before. Having obtained the template, fill in the courses, and fix the cutting mark. It has already been seen that in the semi and segment, the courses have been equal in length, and the bevels alike, but in the camber, the bevel and length will differ in each course; the longer bevel and length being in No. 1, and the shorter in the key. An illustration of the treatment of No. 1 course will serve for all the courses. No. 1 course is the first course upon the skewback. Place the template with its bed side upon the right-hand skewback line, and the cutting mark upon the camber line. Then, where the edges of the template touch the

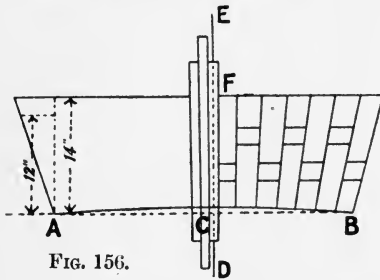

FIG. 156.

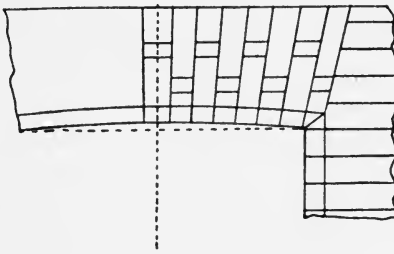

FIG. 157.

camber lines, both top and bottom and on both edges make pencil marks. One mark (the cutting mark), it will be remembered, is already made. Square these marks upon the edges, and connect the two top and the two bottom across the face of the template: this will give the length of the course upon the cutting edge, and the bevels both bottom and top. Serve each course in the same way, and number their bevels upon the template. The arch is 14" on the face, it will therefore be filled in as 8" stretcher, 2" closer, and 4" header in one course, and 4", 2", and 8" in the next, and so on, as before, keying in with a stretcher towards the soffit. The skewback will be treated as in the segment, and all other operations in setting, etc., will be the same. Great care should be taken in grouting in this arch, as it is one of the weakest in construction.

It must be remembered, in cutting this arch, that the different bevels have to be taken off and marked "right" and "left" upon the bottom of the box, as was done in the case of the one bevel in the segment arch (see p. 54).

Moulded Camber (Fig. 157).—The moulded camber should be

treated similarly to the moulded segment, the outside line of moulding being drawn in with the camber slip, parallel to the soffit, meeting the outside line of moulding on the reveal and forming the mitre. The skewback must be taken extra to the moulding, or, in other words, it must be drawn from the outside point of the mitre, so that if a $2\frac{1}{4}$ " moulding be used in a 3' opening, with an arch 12" on the face, the top point of the skewback would fall $5\frac{1}{4}$ " away from the reveal. The shoe mould, etc., would be obtained as in the segment arch.

Camber on Circle.—Arches circular on plan are not to be recommended, as being of weak construction. But where it becomes necessary to use them, they should be strengthened by means of an iron bar bent to the shape.

The mode of setting out this arch and obtaining the template is very simple. Let Fig. 158 be the plan of the sweep to be

FIG. 158.

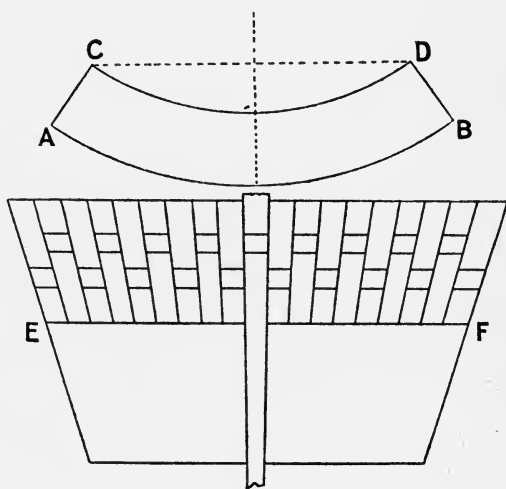

FIG. 159.

covered by a camber arch, of which **AB** and **CD** are the outer and inner faces respectively. Develop **AB** by pricking it over with compasses, or bending a thin lath round the curve and bringing it out as the straight opening **EF**. Upon **EF** construct the camber arch in the ordinary way (Fig. 159), and produce the lines of skewbacks, bringing them down indefinitely below the

soffit or base line. Next develop the inside line **CD** of the plan in a similar manner to **AB**, cutting off its actual length on a rod; then lay the rod in between the skewbacks which are produced below the soffit, till, while keeping it parallel with the base line, it accurately fills in between the skewback lines. Now, with the rod in this position, draw a line which may be termed a sub-base line, and draw the camber line upon it. Next procure the template as already directed (p. 59), taking care that it be long

enough, not only for the ordinary arch, but also to cover the bottom or sub-camber line. Having got the bevels, cutting mark, etc., while the latter is upon the soffit line proper make another cutting mark also upon the bottom soffit line, and the template will be ready for a camber on circle.

When cutting the arch, the upper cutting mark must be used for the face of the arch-brick, while keeping it at the soffit, and the lower cutting mark will be used for the back of the brick, while keeping it in a similar position. By cutting this brick, the student will learn how to prepare the radiating box, one side of which will be higher than the other, according to which side of the arch is being cut. Or, in other words, let it be granted that the left, or leading hand of the arch, is the one to be radiated. Then, having drawn a square line across the bottom, and parallel to the tail of the box, with the face of the brick turned to the body, and the soffit towards the right hand, prepare the box by placing the *upper* cutting mark of the template against the body, and the *lower* one of the other side, to this line.

Should the curve be very sharp, it would cause the arch, if left after the above operations, to appear on the face, as a series of short lines. To avoid this a pair of moulds 10" long, having the same sweep as the plan of the arch struck upon them, and $4\frac{1}{2}$ " only at their widest point, should be prepared. Each course being laid in between these moulds according to the angles their beds make with the base line (for instance, the key-brick will lie at right

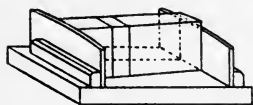

FIG. 160.

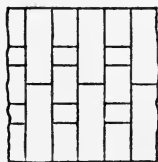

FIG. 161.

angles between the curved sides), would, when cut, receive the same curve as the plan (see Fig. 160). It must be borne in mind, when putting in the skewbacks, that they are radii of the same sweep.

Should the face of this or any arch be 18" deep, then the bonding will be as in Fig. 161.

It will be noticed that the skewback of the 12" segment (Fig. 150) does not come out to the top of the course, making it necessary to put in a small piece of brick; and again that the 14" camber (Fig. 157) is not in depth the multiple of a brick course, necessitating the cutting of an inch course over the arch.

To do away with this cutting, the arches in these and similar

cases may, while maintaining the same bonding on the face, be increased in depth, care being taken that the proportion between the stretcher, header, and closer is relatively the same. Thus by dividing the 15" in the latter case into seven (the number of closers in a stretcher, header, and closer combined), then taking four of these for a stretcher, and two for a header, etc., the stretcher will be found to measure $8\frac{1}{4}$ " the header $4\frac{1}{2}$ " and the closer $2\frac{1}{4}$ "

Equilateral or Gothic Arch (Fig. 162).—Opening, 3'; face, 9".

Draw an indefinite base line, upon it erect a perpendicular centre line, and set out the opening **AB** half each side of it. With the point of the compasses at **A**, and the pencil at **B**, draw the curve or half-intrados **BC**; then with the point at **B** and pencil at **A**, draw the other half **AC**. With the same radius points, and

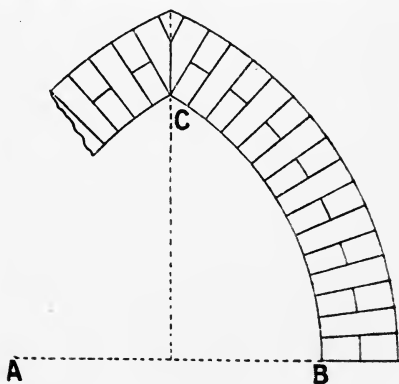

FIG. 162.

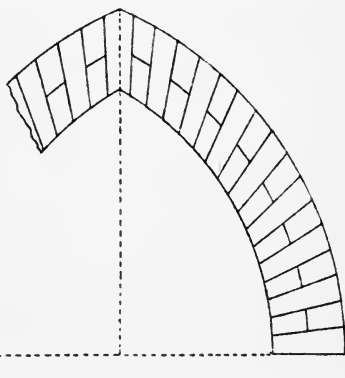

FIG. 163.

the compasses extended to 3' 9", describe the outer line or extrados. When set out properly, this arch, unlike all other arches, has no key-brick, but a joint in the centre. It will therefore be necessary, when pricking over, to allow half a course on each side of the centre line, as though providing for a key-brick. If lines be drawn from **A** and **B** to **C**, it will be seen that each half of the arch is really a segment, and the template will be obtained in the same way, only, where the courses meet on the centre joint, these extra long bevels thus formed will have to be taken from the drawing and marked on the template.

The above is not only the correct method for setting out the Gothic arch, but is also the strongest, as the courses are normals to the curve. But many object to keying, as it is called, with a joint, and insist upon having a key-brick. In the latter case

(Fig. 163) the arch has to be set out, as all other arches, starting with half a course each side of the centre line, and then pricking over to the springing. The approximate key, which is cut as a bird's-mouth, is then filled in from the centre of the base line, and the approximate template obtained and traversed until it is accurate. The courses are then filled in with the latter. Under these new conditions, the courses, not being normals to the curve, will all differ in length and bevel. These will be obtained and marked on the template, in the same way as in the camber (Fig. 156).

The Modified Gothic (Fig. 164).—When the equilateral arch has to be reduced in height, by remembering that the two sides are two segments only, the setting out becomes very clear. Again, taking the 3' opening and 9" face, set out the base and centre lines

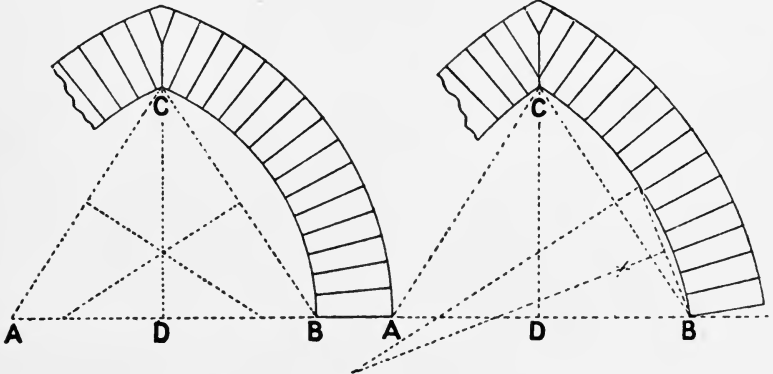

FIG. 164.

FIG. 165.

and the opening **AB**. Upon the centre line set up the reduced height **DC**, join **AC** and **CB**. Bisect **AC** and **CB** with lines square to them (p. 55) and produced to the base line. Where these meet will be the radial points from which to fill in the sides, the template being obtained as in the equilateral arch (Fig. 162). This, like the Gothic arch, may be filled in from the centre of the base line, forming a key-brick, the lengths and bevels differing for each course.

Lastly, should the curves on **AC** and **CB** need modifying (Fig. 165), these may be brought down by treating them as segmental arches, constructing the base line, and marking the height of the curve upon the centre line. Mouldings on these arches are a very simple matter, being treated, when filled in from the radial

point, as the segment, and from the centre, as the camber arch. In neither case is there the difficulty of the mitre to meet.

The Elliptical Arch.—There is no curve in arch-cutting that requires more care than the ellipse, and there is no arch in which faulty setting out, or a cripple, as it is termed, is more easily detected, especially by the trained eye. First, let it be quite understood that it is impossible to set out the ellipse by means of the compasses, though a very near approach may be obtained, when the rise has not to be taken into consideration, by the following methods:—

Case 1 (Fig. 166).—Opening, 3'; face, 9". Lay down the base line with a centre line drawn at right angles above and below it indefinitely, and the opening **AB** half each side, as before. Divide the opening **AB** into four parts in the points **C**, **D**, **E**. With the point of the compasses at **C**, and the pencil at **A**, describe an arc; then, with the same distance in the compasses, but with the point at **A**, cut this arc in **F**. Repeat this on the other side of the opening, and again cutting this arc in **F**.

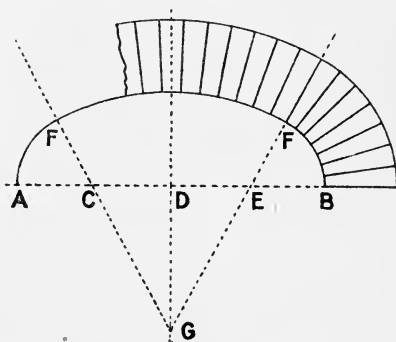

FIG. 166.

Through **F** and **C**, and **F** and **E**, draw lines meeting at the centre line in **G**, and extended indefinitely above **F**. Then, with the point of the compasses at **G** and extended to **F**, describe the remainder of the curve, or intrados, from **F** to **F**. Now, going back to **C**, and the pencil extended 9" beyond **A**, describe the extrados terminating at the line **FG**. Repeat this on the other side of the opening. Then, with the point at **G**, and the pencil extended, draw the topmost part of the extrados. It will now be apparent that in between the lines **GF** there is a segment arch, the template for which will be obtained as in that arch; and that the other two portions are parts of a semicircular arch, and again the template will be obtained as for the latter arch. This is the strongest method of filling in, but the appearance of having two distinct shapes of bricks upon the face is certainly objectionable. The difficulty may be overcome by filling in the arch the same as the camber, or by pricking over the extrados and filling in from

the centre of the base line for the approximate key. The bevels and lengths, of course, will differ, but the bricks will be alike on the face (Fig. 167).

Case 2 (Fig. 168).—Another method of setting out by means of the compasses, with a given rise, the height of the rise bearing a liberal proportion to the opening. Set out the 3' opening as before, calling it **AB**, and the 14" rise **CD**. Join **DB**; cut off **CD** from **CB** in the point *d*; take the remainder *d***B**, and

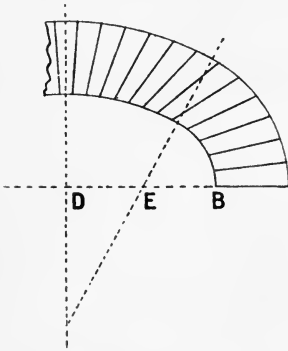

FIG. 167.

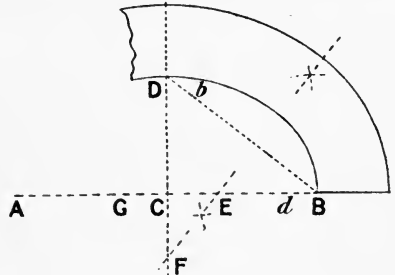

FIG. 168.

cut off **D*b*** from **DB** in the point *b*. Taking any distance in the compasses greater than half **B*b***, and with the point first at *b*, then at **B**, describe arcs cutting each other above and below *b***B**. Through these intersections draw a line cutting the base line in the point **E** and the centre line in the point **F**; then measure from **A**, fixing a point, **G**, upon the base line similar to **E**. Then **E**, **F**, **G**, will be the radial points from which to draw the arch as before.

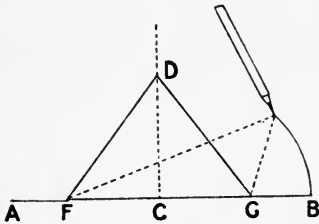

FIG. 169.

Case 3 (Fig. 169) is the string method, answering very well for rough elliptical arches which have to be covered with plaster. Set out the opening, or major axis, **AB**, and the centre, or half-minor axis, **CD**. Taking the distance **CA** in the compasses, with the point at **D**, cut the base line at **F** and **G**. Then, having fixed pins at **F**, **D**, **G**, tie the end of a piece of string or thin wire at **F**, pass it round **D**, and tie at **G**. Remove the pin **D**, insert a pencil in the loop, and, with the string or wire extended as far as it will go, describe the curve.

Case 4 (Fig. 170).—Neither of the above, though useful in

their way, can be compared to the trammel, which is the best practical method to be recommended to bricklayers.

Set out the opening **AB** upon the base line half each side of the centre line **CD**, which will be drawn indefinitely below as well as above the base line. Prepare a square, the sides being about 2" wide and $\frac{1}{2}$ " thick, with a slight bevel taken off the under side of the outer edges; fix the square, the edge of one side coinciding with the centre line, but below the base line, and the other with the right hand, and answering to the half of the base line. Next take a rod (which will be known as a trammel rod) with a fixed pencil point; measuring along the rod from the pencil point, fix a screw, with the head downwards, at a distance equal to the rise **CD**.

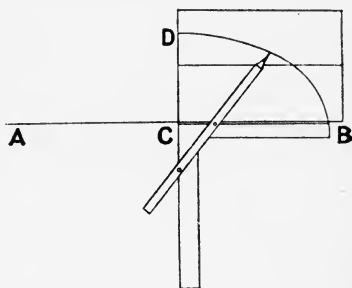

FIG. 170.

Again, measuring from the pencil point, fix a similar screw equal to the distance **CB**, *i.e.* half the opening. Now, take some thin boarding, kept together by ledges, equal to rather more than half the opening in length, and more than the height of the rise in width, with the bottom and left-end edges answering to the right-hand side of the base and centre lines, shot true and square to each other. Fix the mould in position, with the bottom and end edge coinciding with the centre and right-hand half of the base lines. Then, with the trammel rod, the head of one screw working horizontally under the bevel along the top edge of the square, and the other vertically up the square, describe half the soffit upon the roughly prepared mould, which should be properly and truly cut to the curve. This may be termed the master mould. Practice only will give perfection in striking this curve.

It is impossible to attach too much importance to the use of the master mould. The brick-cutter should set out his work to it, and also take the tickings upon it for the centre; the carpenter should use it as his mould for making the centre; and then it should be sent to the joiners' shop, for the purpose of setting out the curve for the head of the frame. Lamentable results have occurred through these three trades working independently.

In setting out the arch (Fig. 171) the mould should be fixed in position, the bottom of it to the base line and the end to the centre

line; then, having drawn the intrados line, a gauge the required depth of the face should be cut, and while one end is worked round

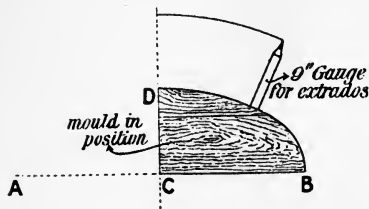

FIG. 171.

the master mould, the other, having a pencil attached, will describe the outer curve, or extrados. The template may then be obtained and the arch filled in as before. It will be seen from this description that theory differs in many points from practice. The extrados in theory is

not parallel to the intrados. In theory also, each face course, or voussoir, being normals to the curve, would differ in shape, and, though not quite impossible, would be most expensive in practice.

In setting out elliptical arches consisting of alternate blocks of brick and stone, the divisions should be in the proportion of 5 to 3 or 6 to 4 respectively; and in large arches each division should be set out normal to the curve, and separate templates obtained for each block of brick and stone. For instance, take an arch for a 7' opening, 2' 3" rise, 12" on the face (Fig. 172), to be

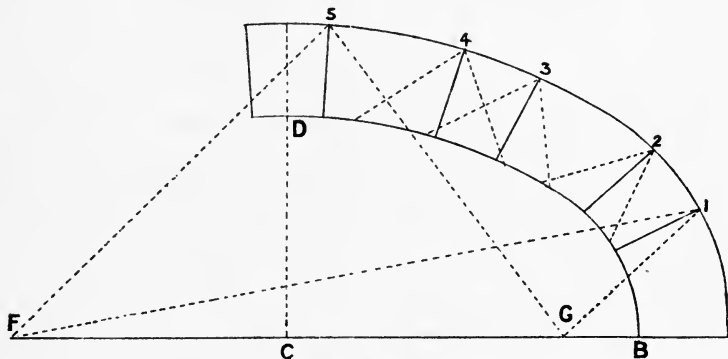

FIG. 172.

filled in with red brick and Bath stone, but starting with red brick and keying in with stone. Set out the opening in either of the ways as shown, then upon the extrados set out the courses of brick and stone, either as 5 to 3 or 6 to 4, whichever comes in most conveniently. In this case 5 and 3 appear to work in the best; so, starting with the key, tick in stone equal to three courses of brick, next to this five courses of brick, then stone, and so on. Number the divisions 1, 2, 3, 4, 5. Now find the foci to the outer curve.

This is done by taking the distance **CB** in the compasses, placing the point of it at **D**, and cutting the base line in **F** and **G**. From tick 1 on the extrados draw lines to **F** and **G**, bisect the angle thus formed, and the bisector will be one of the joints required. Serve the other joints in the same way, and then get the templates for each division of brick.

It would be as well, too, in large elliptical arches, say for 12' openings, built of *brick* only, to make divisions in this manner, and obtain templates for each; for only those who have anything to do with these arches know the difficulty of obtaining one or even two templates for a very large ellipse.

The Scheme Arch (Fig. 173) is one which, while starting off a level bed, has a less rise than a semicircular arch. Let **AB** be the opening, with the centre line **CD**, **CD** being also the 12" rise. Obtain the curve **ADB** as if for a segment, then extend the compasses for the 9" extrados, carrying it down to the springing line. Prick over the extrados, putting in the approximate key from the

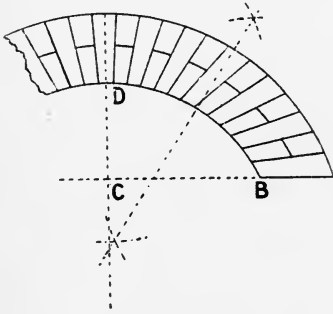

FIG. 173.

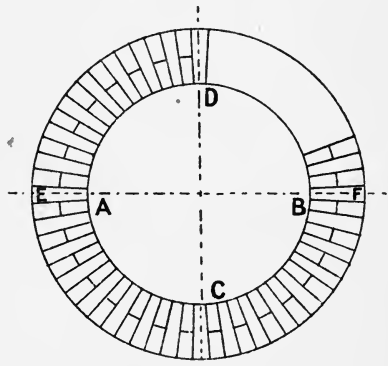

FIG. 174.

centre **C**, and traversing the template until it comes out to the springing line. It will be noticed that the courses differ somewhat in bevel and length, and must be taken off as in the camber.

Bull's-eye Arch (Fig. 174).—The curve of this arch is a complete circle, **AB** and **CD** being the base and centre lines crossing each other at right angles, the curve and face being drawn, and the template obtained as described in the construction of the semi-arch; the only difference is in the disposition of the two side key-bricks, which are placed as **E** and **F**.

The above are the principal arches, but there are various others

which are often used as a mixture of two of the foregoing, and are as follows:—

The Semi-Gothic (Fig. 175) has a semi-circular intrados, but a Gothic extrados. Let **AB** be a 3' opening, with **CD** as the centre line. Set out the ordinary semi; then upon the base line beyond **A** and **B** measure off the face, say 9", and, with either of the methods described for drawing the Gothic, proceed to draw the extrados

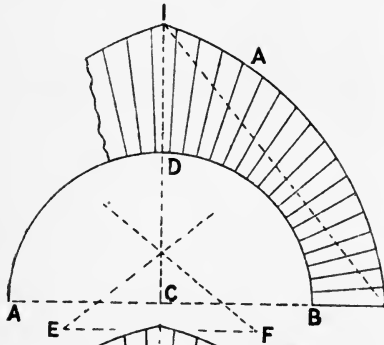

FIG. 175.

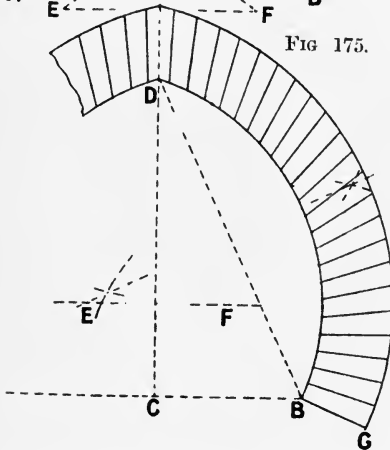

FIG. 177.

according to the height required. In this instance the radius is taken from **E** and **F**. It will now be necessary to prick over the *soffit* of the arch to get the approximate key, putting in a trial key first to ascertain how the brick will hold out towards the top. Having fixed the approximate key, get the template as previously shown. The *soffit* bevels will be the ordinary semi-bevel, but the extrados bevels will all differ, as will the length of the courses. When drawing the arch only, fill in from the centre **C**.

The Ellipse Gothic Arch (Fig. 176).—Let **AB** be the 3' opening, 1' 6" of which is each side of the centre line, and rise **CD**. Divide **AB** into three equal parts in **E** and **F**. From **E** and **F**, with the radius **FB** and **EA**, describe arcs as in the ellipse struck with the compasses, terminating at the points **H** and **G**. Join **HD** and **GD** by faint lines. From **H** and **G**, through **F** and **E**, draw faint indefinite lines. Bisect **HD** and **GD**, and produce lines square to these. The points in which these latter lines meet the lines passing through **HF** and **GE** will be the radial points for the top part of the arch. The extrados will be drawn by extending the compasses from the radial points by which the intrados is struck. Two templates will be used, one answering for the two arcs, and the other for the two segmental portions of the arch.

The Horse-shoe or Moorish Arch (Fig. 177).—This is an arch but very seldom seen, but it is well that the practical man should be acquainted with it. Set out the 3' opening **AB**, and the centre line and 3' 3" rise **CD**. Join **AD** and **DB**; bisect **DB**; set up the rise and describe the curve as in the ordinary segmental arch; from the radial point **E**, through **B**, draw the skewback **BG**; measure the face upon **BG**; extend the compasses, and draw the extrados, terminating at the opposite end of **G** upon the produced centre line **CD**. Treat the other side of the arch in the same way. Although filling in the arch as though there were two segments is far stronger, still a better appearance is gained by pricking over the extrados, filling in the bird's-mouth key from a point made by the skewback being produced to cut the centre line, and then traversing the template, and treating the arch as a scheme. The courses will have different bevels, and will be slightly different in length.

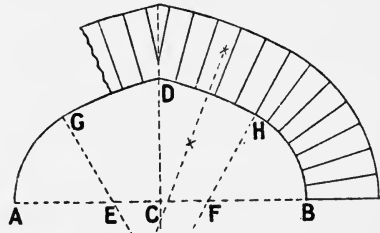

FIG. 176.

The Ogee (Fig. 178) is another peculiar arch, weak in construction, and to be used only as an ornamental feature. Let **AB** be out to out of extrados, and **CD** the rise of the same.

Draw a line from **A** to **D**, and bisect it in **E**. Bisect **DE**, producing the centre line both above and below it, as in the segment, and the same with **EA**. Upon **DE** set up the rise upon that part of the centre line pointing to **DB**, and upon **EA** set up the rise upon the opposite side. Then describe the curves **DFE**, **EGA**, in the ordinary way. From the point **H**, by extending the compasses 9", put in that portion of the intrados from the line **EI** to the centre line **CD**, and from the point **I**, by decreasing the distance in the compasses 9", draw in the part of the intrados from **EI** to the base line **AB**. Deal with the bottom portion of

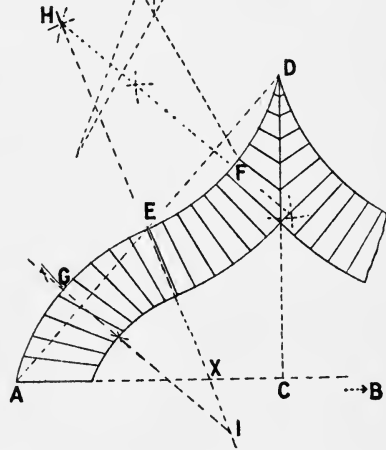

FIG. 178.

the ogee as a scheme, by getting the shape of the template from the point **X**, made by **EI** cutting the base line; and the top part as a segment, obtaining the template from the point **H**. Traverse the templates, accurately fill in the courses, and mark the bevels and lengths.

Arches springing from the same Pier, but differing in Size.—It frequently occurs—in bays, for instance—that while there is one large opening in the middle, there may be a smaller one upon one or each side of it, and that one skewback of the large and one of the smaller arch will be adjacent to each other upon the same pier. Adhering to the rules for skewback, the latter will be at different inclinations, thus presenting a most unsightly appearance. To overcome difficulties such as these must be left to the judgment of the practical man. As an example, two camber arches, one for a 4' and the other for a 2' opening, both 12" on the face, have skewbacks of 4" and 2" respectively upon the same pier. Here an average should be struck, giving each arch a skewback of 3".

As another instance, let there be two segment arches, one opening 4' and the other 2', both of the same rise. In this case the smaller arch should be sacrificed to the larger, keeping the same rise in both, but giving the smaller the same skewback as the larger, thus converting it into a scheme.

Intersection of Haunches.—When two arches spring from the same pier, and the depth of their combined faces more than equals

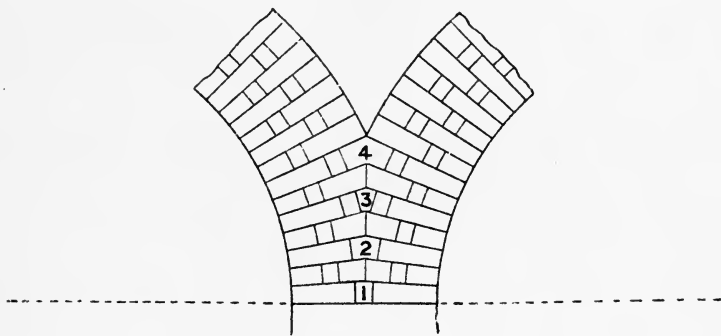

FIG. 179.

the width of the pier, then a proper intersection of their haunches should be arranged. In Fig. 179 two semi-circular arches, 14" upon the face, spring from an 18" pier. The bond on the faces is kept, as far as possible, down to the springing. But where the

outer lines of the haunches meet, the intersection is alternated with saddle-bricks 1, 2, 3, 4, and upright joints. Moulds will have to be procured with which to cut the saddle-bricks.

It will be seen that it is impossible to get the saddle-brick No. 4 out of a brick flat, but it may be obtained by placing the brick on edge, which in this and other similar cases is permissible, the difference being made up by filling in at the back.

THE NICHE.

For years past, to cut and set a niche has been considered a clever achievement indeed; but, as a matter of fact, it is really not so difficult as it appears. By careful attention to directions and rules here given, any practical man of ordinary ability will be able to accomplish it.

Semicircular Niche.—That is to say, semicircular both on plan and on elevation (Fig. 180). First to set out and cut the body, taking the opening as 3'. Draw the opening **AB**, and at right angles to it the centre line **DC**. From the centre **D**, with **DA** as radius, describe the semi **ACB**, then extending the compasses $4\frac{1}{2}$ "

put in the $4\frac{1}{2}$ " thickness of work in the body of the niche. Taking $2\frac{1}{4}$ " or, if necessary, $2\frac{1}{4}$ " full in the compasses, prick over from **C** to **A**, but on the outer

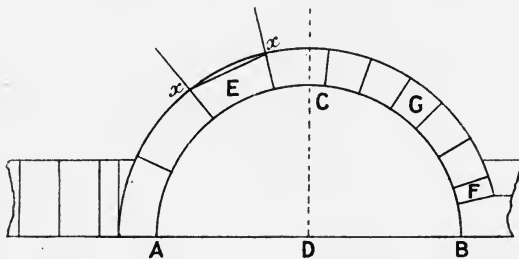

FIG. 180.



FIG. 181.

curve, as many $2\frac{1}{4}$ " as will make an even number of stretchers and a half, so that half a stretcher shall come each side of the centre line. Then with $2\frac{1}{4}$ " again in the compasses, prick over the side **CB**, putting in the headers and closer to bond with the stretchers on the side **CA**. The first header at **B** will appear as a stretcher upon the face, and the first stretcher at **A** as a header, having a closer next it. Moulds must now be cut for the stretcher acting as face header at **A**, for the stretcher **E**, for the header acting as face stretcher at **B**, for the closer **F**, and the bat headers **G**.

The mode of preparing the moulds is as follows: Taking the stretcher **E** as an example, produce the joints **XX**, take two

pieces of board, $10'' \times 4\frac{3}{4}'' \times \frac{1}{2}''$, screwed together, and having one edge shot. Fix the boards down over **E** with the shot edge from **X** to **X**. With the radius **DC**, and from the centre **D**, describe upon them the inner curve. Then with a straight-edge from **D** to the produced lines **X**, draw in the radii, but allowing rather more than $\frac{1}{32}''$ for joint and tinned edges to the mould. Have the mould accurately cut and fitted to the lines, and after tinning they will be ready for use (Fig. 181). They are fixed in a box with the edges which were placed at **XX** downwards. The bricks are prepared by being properly bedded, and one face roughly squared; they are placed in the cutting box, two at a time, the roughly squared face downwards, with the beds tight up to the moulds and fixed. The two ends and two faces are sawn completely over, and finished with a file. Then, having been tested for accuracy by squaring from the bed to face and ends, they are brought to thickness, and are then ready for the body of the niche. The other moulds and bricks will be prepared in the same way. In setting, the plumb-rule, level, and a hand mould answering to the semi

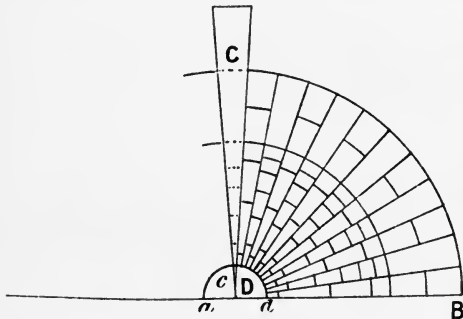

FIG. 182.

ACB, are all that will be required to keep the work true. It should also be tried occasionally, to see that the work is kept to the proper height.

Next to set out and cut the head or hood (Fig. 182). Draw the base line **AB**, and set up the centre line **DC**.

With the point of the compasses at **D**, and the radius **DB**, describe the extrados **ACB**. Then, with the compasses decreased, draw in the 9" face. Prick over the extrados as directed in other arches, putting in the approximate key, and obtain the template, which, unlike that for other arches, will extend from above the outer face to the point **D**. Having obtained the accurate template, place it in position as the key, and with its point at **D**. Then with the point of the compasses at **D**, and the pencil extended to where the template becomes $\frac{1}{2}''$ in width, draw the boss *acd*. Fill in the arch and hood with the template, letting the courses extend from and include the face, home to the boss. Obtain the bevel and the cutting mark as though for the ordinary semi or face arch.

Now take the courses as prepared for the body of the niche ; half a course will answer for the right-hand side of the arch, and half for the left ; but instead of squaring from the bed to the inside face, use the arch bevel, and bevel from the bed to the face, rubbing the bed to make it answer the bevel, and also the squared ends.

The radiating box is now necessary, and is prepared as follows : Make a stout bottom 2" in thickness, in length about 2' 6", *i.e.* somewhat longer than the template, the width being 2' 3", or **DC** of the body plus $4\frac{1}{2}$ " thickness of work, with a little to clear. For the sides of the box, take two pieces of board 2' 6" long and 4" wide, properly shot and tinned on the top edge. Upon the face of one of these boards tack the template, with the cutting edge of the latter flush with the tinned edge of the former. In this position the prepared side will project below the template, and with the bed of the template resting upon the bed of the box, the projecting part of the side will be on the edge of the bottom of the box. Securely nail it there. Scribe the cutting mark upon the tinned edge and remove the template. Go through the same process for the other side, taking care that the cutting marks on both sides are immediately over a line squared across the tail of the box, and the radiating box will be complete (see Fig. 183).

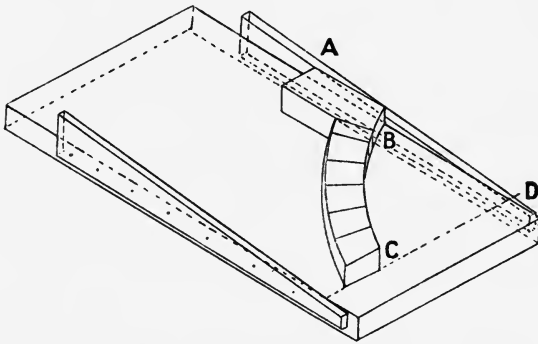

FIG. 183.

Mode of Cutting.—Of the prepared courses, place the brick which answers to the face stretcher, or long header **B** of the body, in the box, with the face to the right-hand or **A** side of the box, and the soffit to the cutting mark, and, measuring away from the soffit of this brick at the cutting mark, and along the side of the box for the radial point **D**, describe the quadrant **BCD**. Place the remainder of the course to this curve ; fix it down ; then,

keeping the wire saw at right angles to the sides of the box, saw the course right over, and keeping the file in the same position, properly finish it, working away from the edge so as to preserve the arrise. With the opposite hand go through a similar proceeding, and the same with the next courses. Cut the solid boss, and the hood will be ready for fixing.

Fixing or Setting.—A solid head or turning piece is not at all necessary. In fact, when using this, the most important part of the work, which when finished will be seen, has to be guessed at while fixing. Instead of this, a hollow semicircular rib to fit the head or body should be made, having an outside rib only, about $\frac{1}{2}$ " thick, so that while the setting proceeds the inside may be seen. Upon this will be marked from the drawing the soffit joints of the face arch, so as to ensure that the work is rising properly. Then, starting upon each side, proceed to fix the work. If the front turning piece should be found insufficient when nearing the key, then a lesser but similar semicircular mould may be used further in. Finally properly grout in the work with Portland cement.

The Elliptical Niche.—This is similar to the semi-circular, but elliptical upon plan. Taking the opening as 3', set out the body upon plan, using the trammel method. Fill in the stretching and heading courses as before, but in this case pricking over the outer and inner curves for the proper shape of the bricks, and obtain the moulds as already directed. The head will be semicircular, and, although the body is elliptical, there will be but one bevel, the courses being placed in the box, not to a quadrant, but to the shape of half the elliptical curve.

Moulded Soffit to Niches.—It will be readily seen that, should the edges of the opening and the soffit of the arch be moulded, this would be cut on the moulds answering to the bricks **A** and **B** (Fig. 180), and would be cut upon these bricks at the same time that they were being shaped for the niche.

LABELS TO ARCHES AND NICHES.

Moulded labels going over camber arches need very little description, being merely moulded bricks as stretchers or headers set over the arch. But when a label has to be fixed over a semi-circular or segmental arch or niche, it is very evident that if straight moulded bricks were run over such arches, their beds would appear as a series of short straight lines, looking most unsightly. It is, therefore, apparent that a curve struck with the

same radius with which the arch was set out must be run on each, and they will also have to be cut to a radial template, in a similar way to an arch; the course, 3" or $4\frac{1}{2}$ " in depth, as the case may be, being set on the top of the arch. If it be 3" deep, then the pricking over on the extrados will be $4\frac{1}{2}$ ".

The bricks will be moulded one at a time. The mode of doing this is to use a pair of clip moulds, which will hang one on each side of the brick (see Fig. 184), placed in the box, bed or soffit upwards; then, after sawing and roughly filing it, the brick should be finished off with a piece of stout sheet iron having a convex curve of the same sweep as the extrados of the arch worked upon it (Fig. 185). By keeping the sheet iron upright while using it, the curve will be worked not only upon the soffit of the brick, but throughout the moulding. After the label has been set, sufficient substance will have been left upon the top edge of the label to admit of its being worked off with a handstone, either to the eye or to a prepared mould.

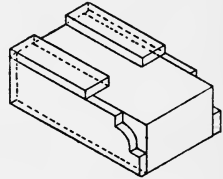

FIG. 184.



FIG. 185.

THE ORIEL WINDOW.

The oriel window, whether in stone or brick, is a most artistic feature in a building. Stone lends itself more readily to the safe carrying out of this work than brick. When built of the latter material, a frame of light ironwork treated with oil or painted to prevent oxidation may be constructed, with the ends either built into the main wall, or bolted firmly to the joists. But, according to circumstances, so the mode of keeping the work in its place must be determined by the practical man.

To cut the oriel, set it up in elevation equally each side of a centre line. Now, if the courses are to be equal in thickness, the centre line, or height, must be divided off into 3" courses. The courses will then appear upon the curve as unequal in thickness. But if they are to appear equal in thickness, prick round the curve at 3". The courses will then really be unequal (see Fig. 186A, in which the setting out is according to the latter system). Set out a pair of moulds for each course, with the curve worked upon each. Draw a horizontal line beneath the elevation, and from each course upon the curvature of the latter, drop perpendiculars to the horizontal line. Then from the centre to each of these

points will be the radius with which to draw the plan of each course. Prick round the outer curve and obtain the template, which must reach from the outer line to the radial point. Different cutting marks will be placed upon the template for each course, working from the outer one towards the radial point (see Fig. 187A). From this plan it will be seen how many bricks will be wanted for each course. To cut the work, bed the bricks, square one face, and mould and take to thickness

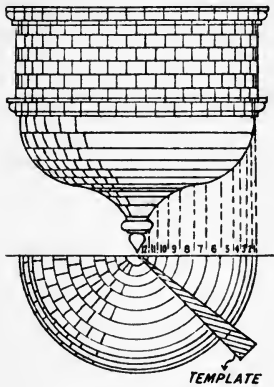

FIG. 186A.

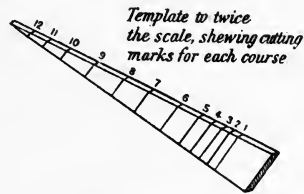

FIG. 187A.

at the same time. Then place them in the radial box at the cutting mark to which they belong, and, after sawing and finishing with the file, they are ready for setting.

In setting, take care to half-bond the courses and properly flush up with Portland cement. An inverse mould fixed at each end, and ribs or moulds answering to different courses upon plan, will be found useful to test the work as it proceeds.

MOULDING BRICKS FOR CORNICES, ETC.

In brick flat moulding for headers, the bricks are bedded, the face squared for right and left hand, and placed bed of brick downwards in the moulding box (see Fig. 138). The bricks are kept in the position by a bridge (Fig. 186B), which is strutted down by means of a long arm working against a springing board above. The wire-saw is taken through the moulding and the upper side of the brick, and finished with a parallel file 16" long, gas barrel, etc. When the brick is finished, the upper side becomes the bed. After this the brick is taken to the width according to the gauge (see p. 80, upon cornices). For stretchers, the operations are very similar; but the head of the brick is squared and placed tightly against the side of the box. Two headers may be moulded at one time, but one stretcher only. For brick-on-edge mouldings, the face of the brick is placed

downwards in the box and the bed to the side. It is possible in this latter case to mould three bricks at a time. It will be readily seen that ordinary returns may be cut at any angle in the box, but that stopped returns and internal mitres will be cut by hand, using the square, chisel, etc., for the purpose.

PILASTERS.

The cutting and setting of plain pilasters require but little more skill than plain ashlar, unless they be fluted or reeded, or both; then a pair of moulds cut to the plan of the pilaster should be used; the brick being worked in the box face upwards, the back of the brick on the bottom of the box being roughly squared. The difficulty lies in setting out the proper bonding of the base and cap. The full-size plan and elevation of each should be worked in conjunction with a few courses of the plain work; the bond accurately set out, and the work cut according to it (see

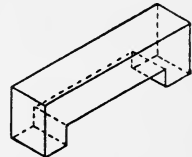

FIG. 186B.

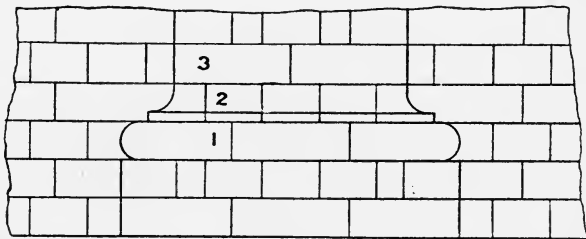

FIG. 187B.

Figs. 187B, 188, which represent the elevation and plan respectively of the base). Here it will be noticed that the bonding

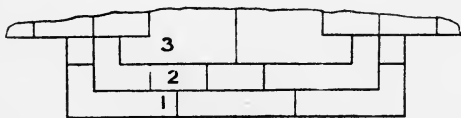

FIG. 188.

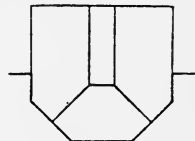

FIG. 189.

of the plain work of the pilaster, and also the general face work, is kept as far as possible, courses 1, 2, 3 of the elevation agreeing with 1, 2, 3 of the plan. The cap of the pilaster is taken in conjunction with cornices.

Pilasters vary in shape upon plan, and the correct bonding must be dealt with as the cases occur; but an instance is given in



FIG. 190.

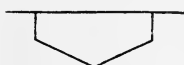

FIG. 191.

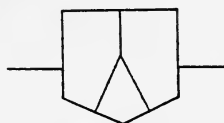

FIG. 192.

Figs. 189, 190 of a half-octagonal pilaster, and in Figs. 191, 192 of a half-hexagonal.

CORNICES.

In setting out cornices, convenient lengths should be taken, *e.g.* from and including pilaster and pilaster, and the whole, or in the case of a long length, the half, or even quarter, should be laid out upon plan, breaking round projecting keys, etc., the setting

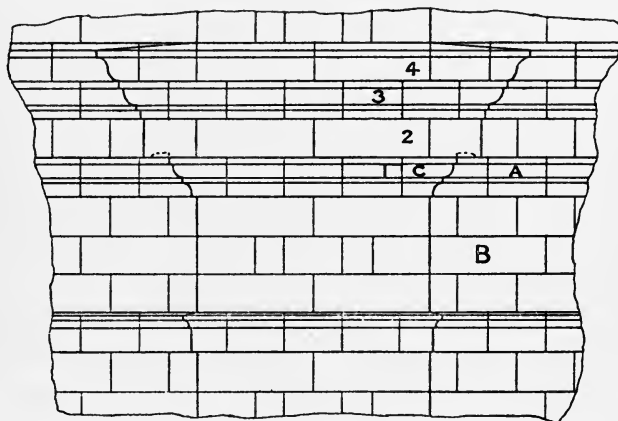

FIG. 193.

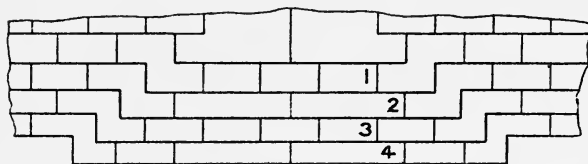

FIG. 194.

out pricked over for headers and stretchers, or, if the projection be too great, then for headers only, so as to get an exact number without broken bond. It may occur that the headers and stretchers are slightly over or under $4\frac{1}{2}$ " and 9"; but, whatever the size, a

gauge is cut to it, and the headers and stretchers reduced to the gauge. The bricks should be joggled, and the work properly run in with Portland cement. All internal mitres, stopped returns, etc., in cornices should be solid. Some brick-cutters make cut mitres, putting them together dry, as being an easier method; but this is not correct work.

It will be noticed (Fig. 193) that the cornice is continued round, and forms a cap to the pilaster; the principal perpends in the plain work of this and of the general face work being continued through the cornice as far as possible. The breaking out of the returns round the pilaster and the bonding between the latter and the straight run of cornice is made out where necessary in between. Thus taking course 1 of the cornice in elevation (Fig. 193), the brick **A** pairs with the plain brick **B**, which goes home to the pilaster. If **A** did the same, then a joint would occur immediately over the angle of the pilaster, and the return would appear as if it were merely stuck on, which would be unsightly; hence, to remove the joint from this point, **A** becomes a bat header, and a solid return is obtained in the three-quarter bat **C**, which, on account of projection, as will be seen upon plan, is made out by a brick shellaced to the back of it. As already stated, it is sometimes necessary for headers only to be used in cornices. This applies with greater force to the top course, where they are frequently bevelled to form a weathering. The bonding of the courses 1, 2, 3, and 4 upon elevation agrees with those marked 1, 2, 3, and 4 upon plan.

DENTILS.

These demand a great amount of thought and care in setting out. In straight runs of cornice, the stretchers or headers should be laid down as in ordinary cornices. Then, taking it for granted that the dentil comes in the stretching course, the dentil itself being $1\frac{3}{4}$ " , and the sinking $\frac{7}{8}$ " wide, and the stretchers being 9" in length, the object is to get an even number of dentils and sinkings in a stretcher, starting with a dentil and finishing with a sinking. It is very evident that $2\frac{1}{2}$ " (the dentil plus the sinking) will not do this, but that $2\frac{1}{4}$ " will. Therefore reduce the dentil and sinking proportionately, by dividing the stretcher into twelve parts, and taking two parts for a dentil and one for a sinking. Now upon a pair of $9" \times 4\frac{1}{2}"$ moulds set out the dentils and sinkings to the

required depth (see Fig. 195). Have them cut and tinned in the usual way, and used in the cutting box dentils upwards.

Dentils breaking round Pilasters, etc.—Fig. 196 is the plan of a dentil course upon a pilaster, and measures $2\frac{1}{2}$ bricks. Starting to set out from each angle with $2\frac{1}{4}$ "

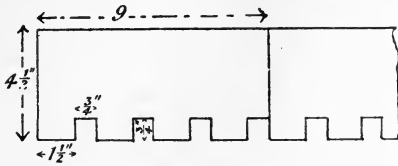

FIG. 195.

it will be found that two sinkings are left in the middle. But it is evident that half a sinking should be left upon each side of a centre line in the pilaster, and hence that there is one sinking too many. In starting from the angle to the centre, there are five divisions of $2\frac{1}{4}$ "

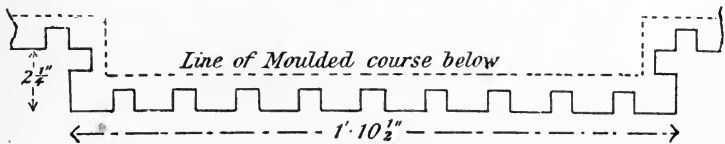

FIG. 196.

by dividing the whole length into twenty-nine parts, and taking two for a dentil and one for a sinking, a dentil will be upon each angle, and a sinking will come in the middle, which is correct. It will also be noticed in the same figure that a dentil with a sinking upon each side of it is shown upon the internal angle formed between the dentils upon the principal line of frontage and those upon the pilaster; this, again, is the only arrangement permissible.

Special moulds, prepared in a similar manner to those for the stretchers, will have to be made for these.

REVEALS.

The principal difficulty with moulded reveals is to get the moulding, course for course, to fit perfectly, depending entirely upon accuracy in working. The mode of working, too, will differ according to whether the reveal be $4\frac{1}{2}$ " or 9" deep. First, with $4\frac{1}{2}$ " reveals, take two pieces of $\frac{1}{2}$ " board, screwed together, cut them off and shoot them square and true, both top and bottom edges, exactly parallel, and to $4\frac{1}{2}$ ". Cut off to 10" in length, squaring the end from the top and bottom edges. From the full-size detail take a tracing of the moulding, lay it upon the prepared sides, prick

through and cut to shape, taking care that the edges are square to the sides. Unscrew the sides, nail them face upwards, one each side of the box, and square with each other. Bed the bricks and roughly square one side. Then with the bed close against the mould and the roughly squared face upon the bottom of the box, one brick each side, and fixed by means of a bridge and strut or long arm, saw close home to the moulds, and finish with file, gas-barrel, or anything most convenient. Take the brick from the box, test the face and end with the square from the bed for accuracy, place it in a reducing box for thickness, and cut off to length or for bonding.

For 9" reveals a different system must be adopted. Take two sides as before, but 9" square, cut the moulding on the edge, then take them apart and form them into a perfectly square box, the

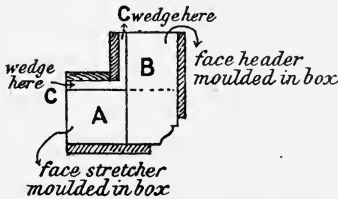

FIG. 197.

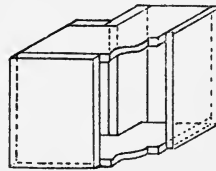

FIG. 198.

sides 9" from each other (inside measurement), as per Fig. 197, which is a section taken parallel to the sides, Fig. 198 being a sketch of the complete box.

To cut the work, bed the brick, square the best face and head, as these will remain the face and head when finished. Then, whether it be for face stretcher or header, so place them in the box, the bed being close to the sides, and the face and head close to the ends of the box, as in **A** and **B** (Fig. 197), then wedge from **C** and cut the moulding only, when the brick will be ready for reducing.

ARCHITRAVES.

These may be formed in the same way as moulded reveals; though, when there is much projection in the architrave, if for 4½" reveals, they will have to be cut from purpose made bricks, or the bricks shellaced together, or each course of the architrave put together in sections.

Fig. 199 is a plan of the heading course of an architrave moulding, **A** being the reveal. It will be seen that the joint **B** is

worked in a convenient member. The two bricks should be cut in the box together, the side **C** standing upon the bottom of the box. Fig. 200 is a plan of one of the stretchers, the piece **A** being fixed on with shellac and white lead (see carving), the same moulds being used as for the heading course, and the box and mould being

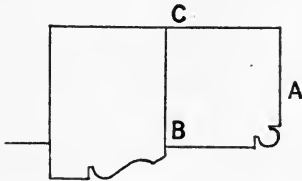

FIG. 199.

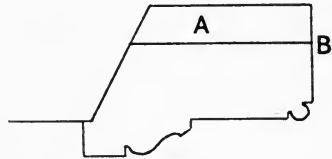

FIG. 200.

made in such a manner as to make it possible, while moulding the stretcher, to cut out a mitre piece, as shown, for the purpose of bonding.

In small architraves, however, with deeply moulded reveals, the joint **B** (Fig. 200) would be objectionable, and it is necessary, if possible, *not* to show a joint. Fig. 201 is the plan of a heading course of an architrave 8" long with $\frac{3}{4}$ " projection, the joint being shown in a suitable position. To obtain the stretchers without joint, pick out the largest bricks; these will often hold out over $9\frac{1}{2}$ " \times $4\frac{3}{4}$ ".

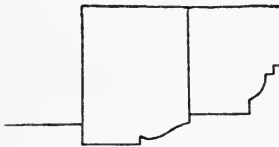

FIG. 201.

Upon the bed mark a bevelled line, **A**, at the end, equal to $4\frac{1}{2}$ " for reveal, plus the $\frac{3}{4}$ " projection, and making together $5\frac{1}{4}$ ". Square from this for the face; measure 8" along the latter, and square from this for the end. Fig. 202 shows the plan of the

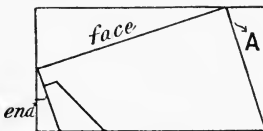

FIG. 202.

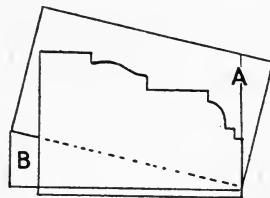

FIG. 203.

brick with the lines marked upon it. Now place the brick in the box, lifting the tail of it till the line **A** coincides with the square ends of the moulds. Fig. 203 is an illustration of the brick in position, showing the side of the box, **B** being a piece shellaced

on to make out the back. In point of construction it must be admitted that this system appears to be weak; but it has been proved over and over again that when two pieces of brick are *properly* shellaced together, the brick will break rather than the joint.

To shellac rubber bricks together, the liquid shellac is poured into water and gently stirred about to remove the greater portion of the spirit; the shellac, very like curds in appearance, is then smeared upon the dusted surfaces of two bricks, the latter rubbed together to make a tight joint, and left to set.

PANELLING.

In setting out panels, the height is usually kept in courses with the general work; but the width is not always the multiple of a 9" stretcher, and needs consideration. Set up a quarter of the panel, whatever the width, including the moulding, and prick over for headers and stretchers. Let Fig. 204 be a quarter of a panel, measuring 4' in width. Had the width been 3' 9", it is very clear that five 9" stretchers would exactly fill it; but, as it is 3" over this, divide the 3" equally among the five stretchers, making them

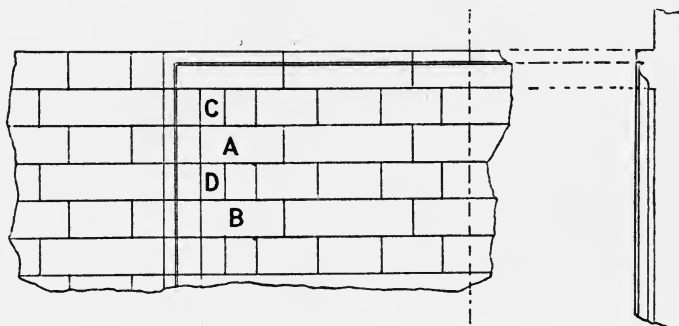

FIG. 204.

slightly over 9", and the headers and closers in proportion. The joints will be arranged as in Fig. 204, the mould for the side stretchers, *e.g.* **A**, **B**, etc., will be as in Fig. 205, one side of the brick being roughly squared and placed on the bed of the box; thus the brick will be worked on edge with the moulding upwards. The moulds for the top and bottom horizontal moulding being as in Fig. 206, and worked with the roughly squared bed of the brick on the bottom of the box, the moulding again being upwards. The side

headers **CD**, etc., will require another pair of moulds (see Fig. 207)

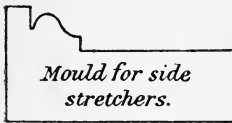

FIG. 205.

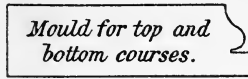

FIG. 206.

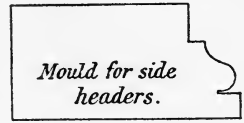

FIG. 207.

the brick being placed in the box on edge and moulded on the end. All angles should be cut in the solid brick, with no mitre joint.

PEDIMENTS.

The mouldings in pediments (see Glossary) are cut and set as already described for other work. The apex, unless it be open, as shown in Fig. 208, will be worked in the solid, and the mouldings at the springing are bevelled off to fit the horizontal work.

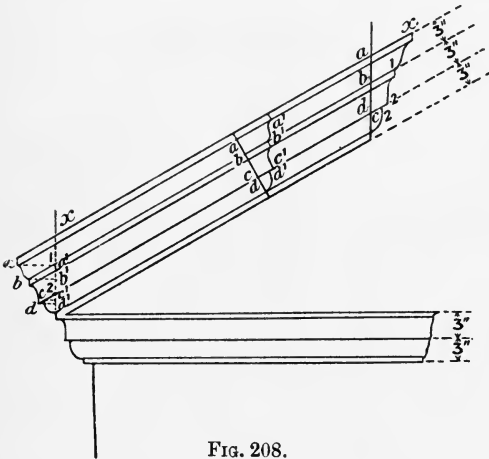

FIG. 208.

The difficulty in pediment mouldings is to obtain what is termed the raking mould. A raking mould is one that is inclined from the level or horizontal plane. Fig. 208 shows the method of obtaining

the raking moulds, that at the foot being the ordinary section or horizontal mould, the next the raking mould, and that at the top the vertical return mould.

CARVED WORK.

Gauged brickwork is a most admirable material for carving, the soft effect produced being quite equal to that of modelling.

The bricks, having been perfectly squared and the projection arranged, are set in a mixture of dried or baked white lead and liquid shellac; being at the same time rubbed together to form a tight joint. Carved brickwork may in this manner be made to

stand out in relief as much as 18"; but when this is the case the work should be arranged from a model, the different projections being taken from this and the work set accordingly, so that the carver will not have more than is necessary to cut away.

PROJECTING KEYS.

A projecting key is sometimes adopted in an arch as an ornamental feature, when some few of the centre bricks, including the key-brick and those adjacent, are made to stand out from the general face of the arch; sometimes being also moulded (see Fig. 209). Whatever size the block may be at the top, it is divided

into odd courses; thus 8", $9\frac{1}{4}$ ", etc., would make three courses; 14", five courses, etc.; the courses being cut to the same template as those for the rest of the arch, though, if necessary, to a different cutting mark. If the projecting key is also to be moulded on the face, as Fig. 209, the bricks are first cut to

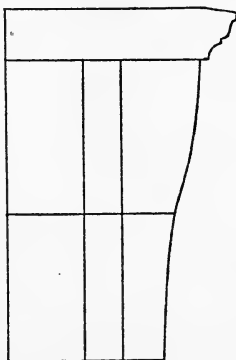

FIG. 209.

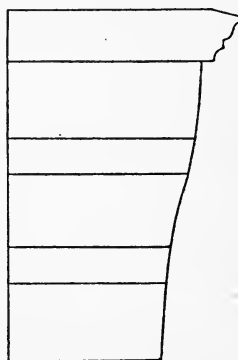

FIG. 210.

the template, the depth and thickness being properly arranged and bonded (Figs. 209 and 210, which show one course in definite and the other in dotted lines), then set, or "blocked," as it is practically known, together with white lead and shellac, and afterwards cut in the box, face upwards, in the same way as ordinary mouldings.

There are many other difficult and interesting details in gauged brickwork, which it is hoped will be treated upon in some future work.

PART III

MATERIALS

BRICKS AND BRICKMAKING.

BRICKS are made of brick earth, which is an admixture of clay and other substances. This, after being moulded to the required shape, is burnt either in kilns or clamps.

Clays used in brickmaking have been found, by analysis, to contain the following, in varying proportions: Silica, alumina, carbonate of lime, oxide of iron, carbonate of magnesia, potash, and soda, water and organic matter.

Alumina is a principal constituent in nearly every kind of clay; it renders the brick earth capable of being easily shaped or moulded.

Silica exists in clay in a state of chemical combination with the alumina, forming silicate of alumina, in which state it shrinks and cracks in drying, warps and becomes hard and tough under the influence of heat; or the silica may be uncombined as sand. The glistening particles seen in the newly fractured surface of a good rubber brick is uncombined silica.

Sand is used with brick earths to prevent cracking, shrinking, and warping, and to provide the silica necessary for the partial vitrification of the materials. It renders the brick shapely in appearance, with good sharp arrises, and more even in texture. An excess of sand renders the brick brittle, and hence unfit for use.

Lime diminishes the contraction of the brick when drying, and also acts as a flux, that is to say, assists to melt and run together the different constituents of the brick. There are two dangers attending the use of lime in brickmaking, the first being that an excess would run the brick out of shape when burning, and the second that, in the latter operation, a small piece, escaping crushing, would be converted into quick-lime, which, upon slaking, would

burst the brick. When a good brick is broken the vitrified appearance is due to the fact that some of the constituents the brick earth contained have become fused.

Iron is that which gives the red colour to the clay after it is burnt, and as the iron increases so the brick darkens in tint.

Magnesia, when present in a sufficient quantity, causes the brick to be yellow when finished.

The Four Classes of Brick Earths.—The first in importance is plastic or strong clay; it consists principally of silicate of alumina. This earth is improved by the addition of mild earth, lime, etc., because a brick made from plastic clay, though it could be easily moulded, would shrink and crack in drying, and warp and toughen only in burning.

Loam, or *Mild Clay*, called also sandy clay. This is a brick earth entirely opposite to the plastic clay. It could not be moulded into shape, but would require the admixture of lime or some other earth to give it the plastic quality.

Marls, or calcareous clays, contain a large proportion of carbonate of lime. This earth needs but little addition of other substances.

Malm is an artificial imitation of natural marl, produced by mixing clay and chalk in a wash-mill. It will be as well, perhaps, to describe here the wash-mill and its uses.

With the better class bricks, such as malm cutters and rubbers, it is absolutely necessary that they should be free from stones even of a very minute size, and this is done in the wash-mill.

The wash-mill is a brick-lined circular trough, having a wide path or horse-track round it, and constructed upon the highest part of the brick-field, the reason for which will presently be evident. It has a centre shaft of iron 15' to 20' in height from the bottom of the trough, kept firmly in its place by brickwork built round the bottom of it. To the shaft or pivot is fixed a light framing running on wheels, called the gin, which in its turn has attached to it, by means of chains, etc., sets of knives and harrows. A horse having been attached to the framing, it is made to move round the iron rod or shaft, pulling with it the knives or harrows, which run upon the bottom of the trough. There is also an outlet from the mill furnished with a strainer, consisting of a wooden frame filled with strips of brass $\frac{3}{4}$ " wide and $\frac{1}{4}$ " apart, and also a shutter to close the aperture when necessary, and lastly, fixed over the wash-mill, there is a water-tap or pump, by means of which the mill is

supplied with water. It has already been stated that the wash-mill may be used for the manufacture of malm earth, in which case clay and chalk, in the proportion approximately of 15 to 1, are shot into the mill. But when it is used for washing earth only, for the purpose of making rubbers and cutters, then that alone is barrowed into the mill. In both cases water is turned on, the knives, harrows, etc., set in motion, and the earth is reduced to a creamy pulp, or slurry. The shutter is then pulled up, allowing the slurry to pass through the strainer along an open trough or shoot of wood, having strainers at intervals, which become finer in mesh as the slurry nears the slurry-pit, back, or vat. The shoot here branches out into minor shoots, so as to thoroughly distribute the mass, and thus prevent, as much as possible, an accumulation of sediment of sand in one place. The brick earth is left here to solidify, and is then ready for moulding and burning. These operations may differ slightly according to the locality; in the case of malm earth, in some localities, the chalk is first reduced to a pulp in a chalk-mill, and afterwards run into the clay-mill; but either of the proceedings given would effect the same desired end.

Brickmaking.—It will be readily understood that the processes of brickmaking will differ according to the different materials found, and hence used, in various parts of the country; but in all, the same fundamental principles are followed.

The first operation is that of unsoiling. The operator, having satisfied himself that the earth is fit for brickmaking, proceeds to remove the turf and mould to the spoil bank. This is also termed "encallowing." The clay is then dug in the autumn, and the various descriptions which it is intended to mix are wheeled to heaps, or kerfs, at a depth of about 2' 6". This, in its turn, is what is termed "soiled in ashes," *i.e.* domestic ashes are spread over the whole to a depth of 6". For what are known as washed bricks a certain amount of malm earth is spread over the top of the ordinary brick earth. The earth is then left during the winter to be disintegrated by the frost, mellowing the clay, and rendering the bricks less likely to warp.

Clearing the earth from stones takes place in the spring. The clay is turned over, and if the stones are not too numerous, hand labour is employed to take them out; if, however, there should be a large quantity of small stones, making it impossible to pick them out, then washing is resorted to; this system, as already stated, is invariably adopted in all the best classes of bricks. Too much

importance cannot be attached to the fact that it is most necessary to clear the earth from stones, for if one fair-sized stone remains, it will crack the brick when drying, and render it unsound after being burnt.

Grinding beneath cast-iron rollers is also expedient, when the brick earth contains a quantity of race, or hard chalk, for, as it has been pointed out, should but a small piece of this remain in a whole state, it will be converted by burning into lime, which, on being slaked, would expand and burst the brick.

Tempering, according to the old system, was a very simple process. The clay was merely turned over with shovels, and, while adding a small quantity of water, trodden underfoot by horses and men. But it has been superseded in most places by the pug-mill. The pug-mill might be described as a huge coffee-grinder. The earth is shot into the top in barrow-loads, thoroughly mixed by knives fixed at right angles to an upright revolving shaft, which is turned either by steam or horse-power, and passes out at the bottom of it ready for use.

Moulding.—Clots of clay are taken from the mill by the pug-boy to the men who are moulding. They have before them a rough moulding bench furnished with a mould, which is an oblong box, having two sides and two ends, the size in the clear being approximately 10" \times 5" \times 3", which fits over a stock board, the latter sometimes having a projection upon it, called a kick, which forms the frog of the brick; a strike, or straight-edge; water and sand-box, etc. The man who stands next the boy goes through the operation of plaiting walks, *i.e.* roughly moulding the piece of earth for the moulder, who thrusts it into the mould, striking it off level with the strike, which is kept, when not in use, in a tub of water.

The next performance is that of bearing off, the method of which depends upon whether the bricks be sand or slop moulded. In sand moulding the mould is dipped into sand each time, and because the moulder never parts with his mould, but sends each green brick away on a pallet, it is also termed "pallet moulding." But in the other system the mould is dipped into water each time, and the mould and brick taken away together.

Each brick is placed in position on the hack-barrow, which is a barrow having a latticed bottom; the bricks are then wheeled to the hack, or hovel, to dry. Taking the bricks from the moulder to the hack is termed "bearing off."

The hacks are long parallel banks raised about 6" above the surrounding land so as to render them dry; the bricks are scintled on the hack eight courses high, and when partly dry, rescintled fourteen courses high, when they are left till dry and ready for burning. An artificial way of drying the green bricks is by means of the hovel, which is a long low-pitched shed, with a floor of thin sheet iron, under which flues are arranged to and fro, rendering the iron hot, and hence drying the bricks which are placed upon it.

Brickburning.—Bricks are burnt in clamps and kilns, and, according to the system adopted, so they must be prepared. For instance, in clamp-burning, the bricks must contain a certain amount of rough ashes, so that in themselves they have the fuel necessary for burning them. And again, as there is no chance of finishing the drying by artificial means, the bricks must be left in the hack a longer period than would be necessary in the case of kiln-burning.

The following is the mode of preparing and building the clamp: The site upon which it is intended to build the clamp is first raised above the surrounding field, to keep it free from water; the ground is made firm and dish-shaped, so that the clamp, when burning, may have a tendency to fall inwards, and paved with half-burnt bricks. The reason for building the sides of the clamp with a batter falling inwards is that when the clamp is fired, the heat expanding the bricks would thrust the outer courses over if the sides were built upright. Then a course of bricks on edge are laid diagonally, with a 2" space between each row, which is filled with breeze and fine coal, and the next course of half-burnt bricks on edge is laid parallel to the sides and close together. While laying these two courses, two live holes, 9" deep and 9" wide, are left throughout the breadth of the clamp, filled in with rough wood and fine coal, and the whole of the site is covered with 5" of breeze and fine coal. Then comes the first course of green bricks on edge laid close together as headers; after this from 4" to 7" layer of breeze; then green bricks on edge are laid alternately as headers and stretchers up to a height of from 10' to 12', the top is covered with about 3" of breeze; the entire clamp cased in with half-burnt bricks, and the whole rendered air-tight by means of brick earth. The quantity of breeze required will vary according to the quality of the clay, but it is estimated that 1000 bricks contain half a chaldron in themselves, and take a quarter of a chaldron of breeze and half a hundred-weight of fine coal to burn them.

The principal kilns in use are—

The Scotch kiln, which is a rough rectangular building, open at the top, with a wide doorway at each end, with fire-holes or eyes protected by fire-bricks, ranged along the sides and opposite to each other; the kiln itself being built with half-burnt bricks set in pug, or brick earth.

A modification of this is the Sussex kiln, in which the fire-holes, facing each other, are connected by means of permanent tunnels, the bricks sometimes being burnt by means of faggot wood.

Hoffmann's kiln is the best known, and is used principally by the largest manufacturers. It consists of an annular tunnel-shaped chamber of brickwork, lined with fire-brick, and divided into twelve compartments by means of iron screens. Each compartment can be constructed to contain 25,000 bricks; the crowding, burning, and emptying may be carried on continuously, and the heat is thoroughly economized.

Cupolas are small circular-domed kilns, used for the purpose of burning Staffordshire blues.

In kiln-burning the drying operation may be finished in the kiln.

Crowding the Kilns.—The bricks are stacked in the kiln on edge, with an inch space between; the fire-holes on the one side being connected to the fire-holes on the other by means of what might be termed small tunnels formed by the green bricks, and the men gradually fill the centre of the kiln, and work themselves out towards the door. The bricks at each doorway are protected by a casing of half-burnt bricks smeared over with pug; the top being served in a similar manner. Slow or small fires are started. When the brickmaker has ascertained, by holding his hand over the top of the kiln, that the steam is driven off, he knows that the drying is complete; he then begins strong fires, continuing them until he sees the fire appearing through the top, when he builds up the fire-holes with half-burnt bricks plastered over with pug, and leaves the bricks to cool.

Bricks taken from a clamp will be found very unequal in quality; those taken from near the eyes are fused together and misshapen, forming burrs; those from near the outside, under-burnt and soft.

Kiln bricks nearly all turn out of the same quality; they need not stand so long on the hack to dry, as the fire can be regulated to finish this process, thus preventing warping, which often occurs with bricks clamped when too moist.

The kiln takes more fuel ; yet the speed, absence of waste, and superior quality of the bricks render it more economical.

Colour of Bricks.—Bricks may be said to be coloured in two ways—naturally and artificially. In natural coloured bricks the earth contains the colouring matter in itself. Thus in red bricks the colour is due to the presence of from 6 to 7 per cent. of oxide of iron. As the proportion of iron and the intensity of heat to which the brick is subjected, increases, the deeper in tone is the colour.

Staffordshire blues are produced from earth containing at least 10 per cent. of iron, which under intense heat is converted into the black oxide of iron.

White bricks are produced from pure clays with the addition of chalk.

Lime and a small quantity of iron produce a cream-coloured brick.

Bricks containing magnesia and iron are yellow after burning.

Lastly, the state of dryness before burning will influence the colour of the bricks. When the brick is thoroughly dry, it will be a clear bright colour after burning, but if not properly dry, a dull cloudy colour.

Artificial Colouring.—Artificially coloured bricks are those which have the colour put on the outer surface after burning. The bricks, after being reheated, are dipped into a mixture of linseed oil, turpentine, a little dryers, and the desired colour, washed with cold water and allowed to dry. If rebaked after this the colour becomes glazed.

Test for Good Bricks.—Good bricks should be free from flaws, stones, or lumps of any kind, uniform in colour, even in texture, with a sharp metallic ring when struck together, have good sharp arrises, surfaces perfectly plane ; they should not vary in size, nor yet absorb more than one-sixth of their weight of water.

VARIETIES OF BRICKS, AND THEIR USES.

Grey Stocks.—For building purposes where strength rather than appearance is required. These are clamp-burnt bricks, made principally for the London market.

Malm Builders.—Used for face work only. Made from specially prepared malm earth and burnt in a kiln.

Red Builders (pressed, dressed, wire-cuts, etc.).—A superior

sand-faced brick, made from washed earth containing at least 6 per cent. of iron.

White Suffolks.—Of a light cream colour, made from a marly brick earth, and used for face work only.

Perforated Gaults.—Made from a blue tenacious clay, used for face work for the purpose of reflecting light. These bricks, instead of having a frog, have circular perforations passing through the brick at right angles to the bed, which is also for the purpose of making them light.

Malm Cutters.—This name is usually given to bricks made from a specially prepared, washed, and strained malm earth; they are of a creamy yellow colour. They are used generally for arch cutting. These bricks are seldom now manufactured, the best of the bright stocks being picked out and sold as malm cutters.

T, L, B Rubbers or Cutters.—Made by Messrs. Lawrence, of Bracknell, from a very fine stratum of earth peculiar to this part of the country; the earth being washed and finely strained as the only preparation before burning. They are used for all embellishments in gauged work.

Fareham Reds.—Both rubbers and builders. An excellent brick of a uniform deep-red colour, made from a moderately plastic clay found in the district of Fareham.

Salt Glazed.—These bricks have a thin glaze on the surface, obtained by throwing salt on them while burning.

Leicestershire Reds.—Heavy pressed bricks. Used for face work.

Staffordshire Blue.—An extremely heavy, dense brick, containing 10 per cent. of iron, which is converted under great heat into the black oxide. They are deep blue approaching to black in colour, and nearly impervious to water. Used in all positions where strength is required, and to resist wear and tear; *e.g.* piers, plinths, quoins to warehouses, for paving railway platforms, courtyards, etc.

Glazed or Enamelled Bricks.—These have a china-like surface of various tints. They are used for the purpose of reflecting light, and for ornamental and sanitary purposes.

Dutch and Adamantine Clinkers.—Small bricks, hard, well-burnt, vitrified, and heavy. Used for paving stables, etc.

Fire-bricks.—Made from refractory clay, and used for furnace work, the principal being Dinas, Stourbridge, Guismuyda, Leemore, and Windsor.

Ganister Bricks.—Made from a hard fire-clay marl found in the coal measures, and superior to fire-bricks for furnaces, etc.

Pressed Bricks.—Bricks that have been pressed in a die when partly dry, to correct warping, etc.

Dressed Bricks.—Bricks that have been dressed with a bat tipped with iron for the same purpose as the above, and while in a similar state.

Polished Bricks.—Similar to the above, but beaten on an iron plate.

Shippers.—Hard, well-burnt shapely stocks, used for export.

Grizzles and Place Bricks.—Under-burnt and weak, not fit for building purposes.

Burrs.—Bricks that have run together in burning. Used for rockery work.

Chuffs.—These are full of cracks, caused through the rain falling upon them while yet hot.

Purpose made Bricks may be divided into two classes, Ornaments moulded bricks, or bricks embellished while in a green state, and at the time of moulding also termed field-moulded bricks. Used for cornices, string courses, and reveals; and various other shaped bricks, as follows:—

Squint Quoin Bricks, used for obtuse angles.

Bird'smouth Bricks, for internal angles.

Bull-nose Bricks, having one rounded end.

Plinth Bricks.—Bevelled bricks, used at the topmost course of the plinth, bringing it back to the neat work.

Various Radiated Bricks, used for egg-shaped sewers, arches, etc.

Coping Bricks of different sections.

LIMES AND CEMENTS.

Limes and cements are produced by burning limestones, either in a pure state or with foreign substances intermixed with them. The larger and denser the stones, the longer will it take to burn them; but this, and many other matters, must necessarily be left to the judgment of the experienced lime-burner.

The exact time it takes for burning seems a matter of no moment, but when it is proved that lime, either over or under burnt, is useless as a cementing material, the importance will at once be seen.

The object of the burning is to drive off the carbonic acid gas;

upon the success of this depends the ultimate production of a perfect lime or cement.

Limes and cements are burnt in kilns of the following shapes:—

- (1) A rectangular prism.
- (2) A cylinder.
- (3) A cylinder surmounted by a truncated cone.
- (4) A reversed straight-sided cone or funnel.

The kiln of the third form, which is lined inside with from 14" to 18" of fire-brick set in fire-clay, is the one most frequently adopted. Kilns are continuous or intermittent, according to whether they are kept going by the introduction of fresh limestone or fuel added at the top, after the lime has been drawn at the bottom, or allowed to go out after each filling, in which case the firing is served from the bottom.

Quick, living, or caustic lime is the resulting lime as left immediately after burning.

Slaking, or "slacking," as practical men term it, is the process of chemical combination of quicklime and water.

Slaked lime, the resultant powder after slaking.

Setting, the hardening of lime which has been mixed into a paste with water. As already stated, the action of burning the limestone drives off the carbonic acid gas, converting the former into quicklime. After mixing into paste with water, the lime immediately begins to reabsorb carbonic acid gas, partly reconverting it into its original form. Sand, being mixed with the lime, gives a ready passage for the gas, thus aiding the setting action, as well as being economical.

Limestones, such as chalk and marble, consist almost entirely of pure carbonate of lime, while in all limes and cements, before calcination, the latter is a principal constituent.

The analysis of limes and cements is given as follows: A small percentage of clay unacted upon, soluble silica, oxide of iron, soluble alumina, sulphuric acid, lime, magnesia, alkalies, etc.

Of these, in the best setting limes and cements, lime is present in the proportion of from 50 to 65 per cent., and soluble silica 20 to 25 per cent. The latter is a most important constituent, as the setting of limes and cements is partly due to the peculiar chemical action between the soluble silica, the lime, and the alumina.

Limes may be placed in two classes, viz. natural and artificial.

Natural limes are produced by burning the pure mineral as found. Artificial go through a manufacturing process before being burnt.

Natural Limes.—These are rich, fat, or pure limes; poor limes; three classes of hydraulic limes; Roman and Medina cement. Plaster of Paris, although not a lime or cement, may also be classed as natural.

Rich, fat, or pure lime is produced from limestone composed almost entirely of carbonate of lime; it is known in the building trades as chalk-lime. This lime absorbs a larger quantity of water, slakes more readily, and increases more in bulk, than any other lime. The increase is from 2 to $3\frac{1}{2}$ times the original bulk of the lime.

Poor lime, which is also known as chalk-lime, is similar to the above, but contains about 15 to 20 per cent. of useless matter. Both of these are fit only for plasterers' work and sanitary purposes; they do not set.

Limes are said to be more or less hydraulic, according to their power of setting under water or in places from which air is excluded. Limestones likely to yield hydraulic lime occur amongst the marly or argillaceous beds.

In all hydraulic limes clay plays the most important part; it is necessary, therefore, to see what property clay has in the setting of limes. It lessens the slaking action, and, when a large proportion is present, the slaking action does not take place at all. Next, it confers the power of setting and remaining in that state under water, or without the presence of air.

Fairly hydraulic limes are produced from limestones containing from 8 to 12 per cent. of clay. They set under water after from 15 to 20 days, and ultimately become as hard as a block of dry soap.

Hydraulic limes,—from limestones in which the above constituent is present in the proportion of from 15 to 18 per cent. The slaking action does not begin until an hour after the water has been added. These limes set after from 6 to 8 days under water, and continue to harden, and ultimately become as hard as the softer varieties of building stones.

EMINENTLY HYDRAULIC LIMES.

These are similar to the above in composition, the clay, however, being in the proportion of from 20 to 30 per cent. Although this lime would probably slake after a long period, it would be

impossible to wait for it to do so. It is therefore sold in the form of an extremely fine powder, in which state, after exposure, it becomes air-slaked. It sets within the third or fourth day, and at the end of six months is similar in hardness to the harder kinds of limestones.

Limes produced from limestones containing much silica in the composition of the clay swell in setting, and are likely to destroy the work in which the lime is used. Those in which alumina is in excess are likely to shrink and crack.

Roman Cement.—Roman cement, which was much used during the early part of the eighteenth century, was discovered by Mr. Parker, who, in 1796, took out a patent for its manufacture. It consists of septaria nodules found in the London clay, which contain from 30 to 45 per cent. of clay. These nodules are burnt in conical kilns at a low temperature, and then ground to powder. The cement should not weigh more than 75 lbs. per strike bushel; it sets in about 15 minutes, but has no great ultimate strength, and is being rapidly superseded by Portland cement. It is sold in casks containing $3\frac{1}{2}$ trade bushels of 70 lbs. To store the cement, it should be kept in a dry place in the casks in which it is received.

Medina Cement.—This cement is produced in a similar manner to Roman, but from septaria nodules found in Hampshire and the Isle of Wight. It is a better cement than Roman.

Plaster of Paris, which, as its name implies, was first manufactured near Paris, consists of gypsum, or alabaster, burnt and then ground to a powder. Uttoxeter is a very noted place for plaster of Paris. It sets in a few minutes, and attains its full strength in an hour or two. It is sold in casks containing 2 cwts.

Before leaving the subject of natural limes and cements, it will be as well, perhaps, to mention that, as they increase in hydraulicity, so in proportion are they weakened by the addition of sand. Thus, chalk-lime will take from three to three and a half parts sand, while Blue Lias, an eminently hydraulic lime, should be mixed with sand in equal proportions to obtain the ultimate maximum strength. Dorking and Halling limes are fairly hydraulic, and will, therefore, take from two and a half to three parts sand.

Other hydraulic limes are Barrow-on-Soar, Whitby, Halkin, Aberthaw, and Arden.

Artificial or Manufactured Cements.—The most important of these is Portland. Why the name Portland should be given to it, one cannot tell. It is supposed to be because it resembles

Portland stone ; or again, why the name cement should be given to Portland, Roman, Keenes, Parian, etc., and not to ordinary natural limes, it is hard to imagine ; properly speaking, the word is generic, and should include all substances capable of cementing together small materials.

At what exact date Portland cement was first manufactured, it is difficult to state, but it was probably about the beginning of last century. It was known that limestones capable of producing an hydraulic lime contained a proportion of clay, and that their hydraulicity was due to clay, and it was doubtless this that first suggested the manufacture of Portland cement.

It is produced by intimately mixing and calcining together clay and chalk, by either the wet or dry process. The system best known in this country, and as adopted on the banks of the Thames and Medway, is that known as the wet process. The reason for establishing the works on the banks of the Thames and Medway is because the flow of these rivers brings down in their beds the clay suitable for the manufacture of the cement.

Briefly, the process of making Portland cement is as follows : The works, fitted with machinery, are established near a chalk-pit, and also within easy distance of the special clay required. The proportions of chalk and clay, approximately three parts of the first to one of the latter, are accurately weighed, the correct quantities being ascertained by both chemical and mechanical tests, and are then shot into a wash-mill. The wash-mill is very similar to a mortar-mill, with these differences—the wash-mill is much larger, and, instead of having grinding stones, it has large fans attached to a centre shaft which revolves rapidly, the pan being stationary, and reduces the clay and chalk, to which water has been added, to a creamy pulp, or slurry. This then passes through a sluice or strainer in the wash-mill, which has been opened purposely, into an oblong chamber about 10' \times 4', having no ceiling, but opening at the top into a room above, and containing a huge wheel or elevator about 8' in diameter, with what appear like shovels or buckets attached to its circumference. The elevator throws the slurry to the floor above, where it sinks through a hole or gully, and is pumped by a large Archimedean screw (that is, a spiral revolving in an ordinary pipe) to grinding stones acting in a similar manner to the stones of a flour-mill, through which the slurry passes, being ground to a still finer pulp. Another pump conveys the mass to the hot beds. These are tunnel-shaped chambers about 10' square

(formed behind the kilns), the floors consisting of plates of sheet iron covering flues, through which the otherwise wasted heat from the kilns has to pass. The end of the pipe opens into the chamber, and the slurry is made to flow over the floor to a depth of about 12". It is here left to become thoroughly dry. At the end of the chamber is an opening covered with an iron door. When the kiln is being charged, this door is opened: the fire at the bottom of the kiln is laid, the dried slurry is broken up and shovelled through the opening into the kiln, and the fire lighted, burning the slurry to a hard clinker. As soon as it is properly burnt, and the contents of the kiln are cool, the charge is drawn, the clinkers, as hard as iron, being separated from the spent fuel. The clinkers are then shot into a huge mill, similar to a coffee-grinder, in the floor of the yard, to be reduced to a coarse powder, after which it is conveyed by an Archimedean screw to the floor above, where it is again pumped upon some millstones to be ground to a fine powder. Next, it is pumped from here upon an inclined sieve, the finer particles passing through and being conveyed to the cooling floor, while the coarser are lifted back again to the grinding stones. The mesh of the sieve is from 1600 to 2500 per square inch.

The question has often arisen, "Does Portland cement swell?" This is a most important consideration, especially to sanitary engineers, because most of the earthenware drains are cemented together by well punned and trowelled Portland cement. It is beyond doubt that it does swell, and that failure of drainwork is frequently due to this fact; and the better the joint the more likely the failure. As proofs of this, take samples of the best Portland cement, first neat, gauge with just sufficient water to form a paste, carefully fill three glasses with this, excluding all air-bubbles, etc. Now, place one under water, one in moist ground, and one in the dry. After a week or two the effect will be apparent. The glass under water will be badly broken, that under ground will be less affected, that in the dry intact; but as time goes on the fractures in the first two will develop, and the third will also become fractured. The same effect, but to a less extent, will be produced if the cement be gauged with an equal part of sand.

Without sand the coarse-grained cement is the stronger, but the finer grained is always the most reliable.

Portland cement should weigh from 95 to 130 lbs. per strike bushel; the heavier cements being slow-setting, but stronger. The colour should be grey or greenish grey, and the breaking weight

from 350 to 400 lbs. per square inch after seven days' immersion in water. It is sold in sacks of two trade bushels, weighing about 200 lbs., and if stored should be shot upon a dry floor of a dry shed, and turned over occasionally, so that it may become thoroughly air-slaked. If, when plunging the arm into the cement, it appears hot, it may be concluded that the cement is not properly air-slaked, and is therefore dangerous to use.

Keene's Cement is prepared by soaking plaster of Paris in small lumps in a solution of alum and water, then exposing to the air for 8 days, reburning and reducing to powder. Copperas is added to enable the cement to withstand exposure to the weather. It is this which gives the cement a pinkish tint. It is sold as "fine" and "coarse," in barrels of $3\frac{1}{2}$ and 3 bushels respectively.

Parian Cement is prepared in a similar manner, the solution being borax, alum, and water.

SAND.

There are three classes of sand—pit, river, and sea.

Pit Sand is angular, porous, rough, and sharp in grit, making it by far the best for mortar. It is sometimes found mixed with clay, rendering it necessary to wash it, as all sand for mortar-making should be thoroughly clean.

River Sand has the advantage of being clean, but the action of the water rounds the grain, making it less valuable for building purposes, but extremely useful for plastering.

Sea Sand, like the above, is rounded in grain. It has also the disadvantage of being salt, thus absorbing the moisture from the atmosphere and rendering the work damp.

Road Drift from country roads is a good sand, but requires careful washing to remove vegetable and animal matter.

Sand, for all ordinary purposes, need be screened only, so as to remove the large stones. For finer work it must be sifted, and, when necessary, washed to cleanse from dirt, etc., as the latter is most detrimental to mortar-making.

Substitutes for Sand.—The mortar-mill has given rise to the use of many of these. Thus sandstone or granite chippings form an excellent mortar. Burnt ballast makes what practical men term a greedy or hungry sand, turning out a mortar that sets, but does not adhere to the brick or stone. Broken bricks may also be placed under this heading; while smithy ashes form a first-class sand for black mortar.

CONCRETE, MORTAR, ETC.

Concrete is an artificial mixture, consisting of a hard material as the base, bound together with either lime or cement mortar.

The hard material, such as broken stone and brick, gravel, slag, etc., is known as the aggregate, while the cementing material is called the matrix.

Concrete may be said to bear a close resemblance in its structure to brick or rubble walls, though the hard material is smaller, and there is no possibility of bonding with it. It must therefore solely depend for strength upon the cementing material, the object being to thoroughly encase each piece of stone, brick, etc., with it, leaving no voids.

The aggregate must be thoroughly clean, broken to go through a $1\frac{1}{2}$ " to 2" mesh, and the surface of the pieces should be angular and rough, so as to form a key for the mortar. Position in which the concrete is to be used will determine the choice of material; *e.g.* where weight in the concrete is desirable, then a heavy material, such as broken stone, brick, etc., should be chosen; but for floors and other light constructions, coke breeze, etc., would be preferable.

The matrix should consist of either Portland cement or Blue Lias lime and sand. The proportions for the concrete must depend upon the situation in which it is to be used; but for ordinary purposes the following may be accepted:—Five parts clean broken stone, brick, etc.; two parts sand; one Portland cement, or blue Lias lime. Or seven parts Thames ballast (already containing sand); one part Portland cement, or Blue Lias lime.

In mixing, care should be taken that the materials are kept clean: a wooden platform or paved surface is therefore advantageous. The materials must be accurately measured, carefully incorporated, being turned from two to three times while dry, and several times while just sufficient water to bind them together is being sprinkled through a rose over the mass. It is very clear that if too much water be added, the mortar will be so soft as to escape, or when lowered into the trenches the aggregate will sink to the bottom, leaving a bed of mortar only at the top.

When covering a site with any considerable depth of concrete, it should be carefully lowered and gently punned in about 12" layers, and allowed to set, care being taken that as each successive course is added, the last layer be roughed and wetted to form a key.

Mortar.—This may be divided into two classes—mortar for building purposes, and mortar for pointing, the latter being called by practical men “pointing stuff.”

Building mortar may again be divided into two classes—cement mortar and lime mortar, the first being distinguished as *compo*, from the latter, which is generally called mortar only.

The decision as to the quality of the mortar will depend upon where it is to be used. Thus, for work under water, footings, piers receiving heavy weights, etc., Portland cement or Blue Lias would be used; for ordinary purposes, fairly hydraulic, such as grey stone lime. Fat or poor limes should never be used for building brickwork.

The proportions recommended are as follows: Above ground: Fairly hydraulic lime, one part to three sand; eminently hydraulic lime, one part to two sand; Portland cement, one part to five sand. For footings: Eminently hydraulic lime, one part to one sand; Portland cement, one part to two sand. For work washed by water, such as river walls, etc., Portland cement and sand in equal proportions.

A greater proportion of sand than the above is often used with eminently hydraulic lime and Portland cement, and a good hard mortar results, but the ultimate strength is not attained.

Sand, as already stated, serves the purpose of admitting carbonic acid gas to the lime, and is also used for the sake of economy.

Mode of Mixing.—A clean site or platform having been chosen, the lime and sand should be measured out in a yard measure. In the case of fairly hydraulic lime, which is supplied in lump, the screened sand is formed into a ring, the lime shot into the middle, and sprinkled with just sufficient water to slake it. Some of the sand is then turned over the lime, and it is left in this state till the lime has become thoroughly slaked. Water is then added, the remaining sand gradually pulled in, and the whole mass carefully incorporated with a larry and shovel.

For hydraulic limes and cements, which are supplied in a powdered state, the lime and sand are again measured and shot upon a platform, the sand first and the lime upon the top of it. These are mixed together, first in a dry state, and then with just sufficient water to form a fairly stiff paste, in order that the lime or cement may not escape with the water. With the latter mortar small quantities only should be mixed at a time.

The mortar-mill is now frequently used, but, though a finer

mortar may be turned out, it is often not so good as that made by hand. This applies more especially to cement mortar. The mill is also a means of using materials that are really not fit for making mortar.

Mortar for Pointing.—Yellow pointing stuff, sometimes called stopping. One of the most objectionable modes of treating old and sometimes new brickwork, is to rake out the joints, colour the work as a poor imitation of new malm bricks, fill in the joints with stopping, rub over, in the case of old work, with a piece of sacking, and new, with a brick, and then joint with either a white or black tuck joint. In stock, or yellow malm facings, in which yellow stopping is used, the brickwork is coloured with a solution of copperas and water, sometimes with a little yellow chrome added to give a brighter colour; experiments being made upon an old brick, or a portion of the work hidden from view, so as to hit upon the desired tint.

The yellow stopping is composed of fairly hydraulic lime one part, fine washed sand three parts, and sufficient yellow ochre to make the stopping of the same tint as the copperas-washed brickwork.

For red brickwork, the colouring solution is made up of Venetian red and Spanish brown, in the proportion of about 2 lbs. of each to $3\frac{1}{2}$ gallons of water, according to the desired tint, 1 lb. of copperas, and sometimes beer, to set the colour. The mortar will be similar to the above, with the exception that the colouring matter is Venetian red, with a small amount of vegetable black.

Putty for pointing is made of silver sand and stone lime, two of the first to one of the latter. The lime, being dry slaked, is mixed with the sand, passed through a very fine sieve, mixed with sufficient water to form a very hard paste, oil sometimes added to make it work better, and then well beaten with a club hammer or other heavy instrument. For black putty, vegetable black is added to the above, the quantity being about $1\frac{1}{2}$ cwt. to 1 cubic yard.

There are several other fancy-coloured mortars, such as pink, chocolate, etc., the object being to make a contrast between the brick and the joint. Thus a deep chocolate blends well with red facings, etc.; but being too numerous to deal with individually, the colouring must be left to the judgment of the practical man.

THE METHOD OF MEASURING BRICK- WORK, CONCRETE, POINTING, ETC.

Most bricklayers know how to use the foot rule in measuring ordinary work, but, having attained the measurement, the difficulty arises as to how to square or cube the quantities thus obtained. Another difficulty also met with is how to take the measurement of awkward shapes, *e.g.* gables, arches, etc. This chapter, therefore, is intended to help those who have no knowledge whatever of the subject.

In the building trades, measurements are taken as foot run, foot super, or square, and foot cube.

Foot run relates to length only; for instance, drains, tile-creasing, cutting under 6" wide over circular arches, cement fillets, etc., are taken and priced at the foot run. In this there are 12" to a foot, and 3' to a yard.

Foot super, or square.—Here length is multiplied by width or height; a paved floor, so many feet long by so many feet wide, will have so many feet super, or square, of paving. In a square foot there are 144 square inches. To make sure that this is so, draw a square 12" long by 12" wide, and divide up into inches; it will be seen that there are 144. But in the building trades, both with square and cube measurements, twelfths of feet are reckoned upon. So 6 square feet 72 square inches would be written as 6' 6" super. There are also 9 square feet in a square yard. This may be proved by laying down a square 3' long by 3' wide, and dividing into squares 12" by 12", when nine squares will have been formed. Foot super is used in measuring facings, paving, tiling, etc.

Cube measurement is length \times (multiplied by) thickness \times depth or height. Thus, in finding the cubic contents of an 18" square pier, say 6' high, it would be stated, as 6' \times 1' 6" \times 1' 6". In the cubic foot it will be seen (Fig. 211), that there are 1728 cubic inches. That is to say, that 1728 wooden cubes 1" \times 1" \times 1"

may be built up to form a cube 12" long, 12" broad, and 12" deep. Here again, instead of reckoning 1728 inches, the cubic foot is divided into twelve cubes, and 6 cubic feet 864 cubic inches is written as 6' 6" cube. There are 27 cubic feet in a cubic yard, as may be seen by making twenty-seven cubes 12" × 12" × 12", and piling them together to form a cube 3' × 3' × 3'. Cubic measurement is used for excavations, concrete, etc.

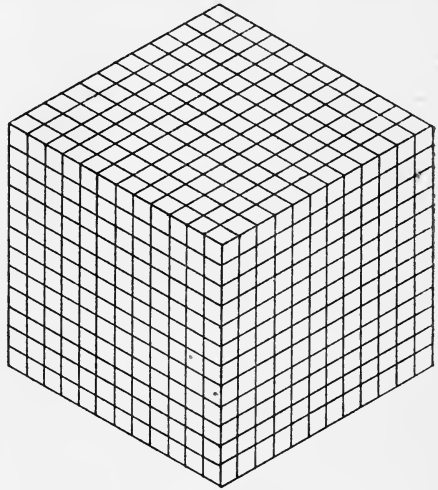

FIG. 211.

Before squaring dimensions, a perfect mastery of the multiplication tables up to 12 times is necessary. A thorough knowledge of these tables will also be sufficient for division when needed. Thus, knowing that 12 times

9 are 108, then 12 into 108 = (equals) 9, and 12 into 112 = 9 and 4 over, or 9 into 108 = 12, and 9 into 112 = 12 and 4 over, etc. A constant practice in this will be invaluable in squaring dimensions.

There are several arithmetical methods of squaring dimensions, but for those who are not expert it would be better to adopt one system only. An easy and accurate method is that known as cross multiplication, or duodecimals. By duodecimal is meant multiplication by twelves. Take as an instance 5' 7" × 2' 4", or, as it is written—

$$\begin{array}{r}
 5' \ 7'' \\
 2' \ 4'' \\
 \hline
 11' \ 2'' \\
 1' \ 10'' \ 4''' \\
 \hline
 13' \ 0'' \ 4'''
 \end{array}$$

Here, start to multiply 5' 7" by the 2', and say twice 7 are 14; 12 into 14 = 1 and 2 over; place the 2 under the 4, and carry 1. Next, twice 5 are 10, and the 1 carried = 11; place this under the 2'. Proceed with the multiplication by 4", and say 4 times 7 are 28; 12 into 28 = 2 and 4 over; place the 4 in the line under 11' 2", but one place to the right of the 2", and carry the 2. Then 4 times 5 are 20, and the 2 carried make 22; 12 into 22 = 1 and 10 over; place the 10 under the 2", and 1 under the 11'. Add these

two lines, starting with the first figure to the right: so 4, with nothing added = 4, bring it down in its place; 10 and 2 (or $10 + 2$) are 12; 12 into 12 = 1 and none over, place 0 under the 10, and carry 1; the 1 carried + 1 + 11 are 13, place the 13 under the 1; and the answer will be 13'. Whenever in the place twice removed to the right of the feet (or where 4 appears in the last result), the figure is 6 or over, reckon this as one more to the place to the right of the feet (or where 0 appears in the last result), but when under 6 discard it. Thus, if the last answer had been 13' 0" 7"', call it 13' 1", but, being 13' 0" 4"' only, it should be taken as 13'.

Cubing.—Let 6' 4" \times 2' 11" \times 3' 6" be the dimensions, written as—

$$\begin{array}{r} 6' \ 4'' \\ 2' \ 11'' \\ \underline{3' \ 6''} \end{array}$$

Proceeding as before (see below), begin by multiplying 6' 4" \times 2', and say twice 4 are 8; this cannot be divided by 12, so place it under the 11. Twice 6 are 12; place this under the 2'. Then multiply by the 11"; 11 times 4 are 44; 12 into 44 = 3 and 8 over; place the 8 under the 12' 8", but one place to the right of 8, and carry the 3. Then 11 times 6 are 66, and the 3 carried make 69; 12 into 69 = 5 and 9 over. Place the 9 under the 8, the 5 under the 12, and add the two lines: 8 and 0 = 8, write it in its place under the 8; 9 and 8 are 17, 12 into 17 = 1 and 5 over, place the 5 under the 9 and carry the 1; 1 and 5 are 6, and 12 are 18, place the 18 in its proper position as feet; and the result so far is 18' 5" and 8". Multiply this by 3' 6", placing the 3 under the 18, and the 6 under the 5. As before, first multiply by the feet, and say 3 times 8 = 24; 12 into 24 = 2; carry the 2 and place 0 in the line, under the 3' 6", but to the right of the 6. 3 times 5 = 15; and 2 = 17; 12 into 17 = 1 and 5 over; place the 5 under the 6 and carry 1. 3 times 8 are 24, and the 1 carried makes 25; place the 5 under the 3 and carry 2. 3 times 1 are 3 and 2 = 5; place it to the left of the last 5, making 55. Then multiply by the 6", and say 6 times 8 are 48; 12 into 48 = 4 and 0 over; again place the 0 under the 55' 5" 0, but one place to the right of the 0, and carry the 4. 6 times 5 are 30, and the 4 carried, 34; 12 into 34 = 2 and 10 over; place the 10 under the 0, and carry 2. Then multiply 18 by 6, adding on the 2, and making 110; 12 into 110 = 9 and 2 over, place the 2 under the 5, and the 9 under the

right hand 5 of the 55. Add the two lines together; 0 coming first, bring it down; 10 and 0 are 10, bring down the 10; 2 and 5 are 7, bring this down; 9 and 5 are 14, put down the 4 and carry the 1; 1 and 5 are 6, put the 6 to the left of the 4. The answer is 64' 7" 10''' cube, or 64' 8" cube. Dividing this by 27, we get 2 yards 10' 8" cube.

$$\begin{array}{r}
 6' \ 4'' \\
 \underline{2' \ 11''} \\
 12' \ 8'' \\
 5' \ 9'' \ 8''' \\
 \underline{18' \ 5'' \ 8'''} \\
 3' \ 6'' \\
 \underline{55' \ 5'' \ 0'''} \\
 9' \ 2'' \ 10''' \ 0'''' \\
 \underline{64' \ 7'' \ 10''' \ 0''''}
 \end{array}$$

Timesing.—When a dimension occurs several times over, it is written thus—

$$2 \left| \begin{array}{l} 5' \ 7'' \\ \hline 2' \ 4'' \end{array} \right.$$

which means that the result of 5' 7" × 2' 4" is to be multiplied by 2; and looking back to p. 107 it will be seen that this is 13' × 2, which is 26'.

Again, a quantity written as—

$$3.2 \left| \begin{array}{l} 5' \ 7'' \\ \hline 2' \ 4'' \end{array} \right.$$

or dotting on, as it is called, means that the result of 5' 7" × 2' 4" is to be multiplied by 2 added to 3, or 5; and the whole result would be 65'.

Digging is taken at the yard cube, and depends for price upon the depth, and the distance the earth has to be wheeled or carted.

The least amount of depth of trench for a 14" wall, including footings and concrete, would be 2' 3"; the width being 3' 3". Then, taking it that the measurements of digging to trench for a 14" wall 20' long are required, the trench itself would be 20' + (3' 3" - 1' 2") = 22' 1" × 3' 3" × 2' 3". The 2' 1" being projection of footings, concrete, etc., at each end; and the amount of concrete, 22' 1" × 3' 3" × 1' 3". These dimensions may be obtained by drawing the plan of the footings and concrete for length and width, and setting up the section for depth, as already shown on p. 8.

Concrete of less thickness than 12", or where under pavings, etc., is taken at per yard super.

In brickwork the difficulties of measuring are somewhat greater. The London practice is to reduce all work of $1\frac{1}{2}$ bricks thick and upwards, to a standard of 272' super $1\frac{1}{2}$ bricks thick, which is called a rod; the actual measurements being $16\frac{1}{2}' \times 16\frac{1}{2}' \times 1\frac{1}{8}'$, or 306.2812 cubic feet, reckoned in practice as 306 cubic feet. Walls under this thickness are generally specified with the work they entail, *e.g.* struck joints both sides, pointed, circular, etc. When measuring footings, for instance, multiply the average length by the average thickness, and then by the height. When taking the average thickness, first add the width of the top course to the width of the bottom course in bricks, and divide by 2; thus for a 2-brick wall, $2 + 4 \div 2 = 3$. Then the average thickness will be 3 bricks, or 2' 3". (When the bottom course is doubled, take one of these courses separately, and afterwards add.) Taking the length of wall to be 20', the average length of the footings will be $20' + (2' 3'' \text{ average thickness} - 1' 6'' \text{ width of neat work}) = 20' 9''$. The height of the footings, as already shown, including one course of the wall, will be five courses, or 15", and the quantity of footings = $20' 9'' \times 1' 3''$, 3 bricks thick = 25' 11", or 26' of work 3 bricks thick. By multiplying 26' by 6 (the number of half-bricks in 3 bricks), and dividing by 3 (the number of half-bricks in $1\frac{1}{2}$ bricks), the work will be brought to the standard measurement, $26' \times 6 \div 3 = 52'$.

In ascertaining the quantity of digging, to trenches, concrete, and footings, for a rectilinear building, much labour may be saved by taking an average. Let **ABCD** (Fig. 212) be the plan taken through the 3-brick wall of a building 50' \times 30' out to out. If mitre lines be drawn from **A** to **E**, **B** to **F**, **C** to **G**, and **D** to **H**, and lines midway between the inner and outer lines, but terminating upon the mitre lines be also drawn, the average length of the walls will be found to be $2/47' 9''$ and $2/27' 9''$. Then the digging for trenches will be $2/47' 9'' + 2/27' 9''$, or $151' \times 5' 6'' \times 3' 10''$, which = 3183' 7" cube, or 117 cubic yards 25 cubic feet. Concrete $151' \times 5' 6'' \times 1' 10'' = 1522' 7''$ cube, or 56 cubic yards 11 cubic feet. Footings, average thickness = $(3 + 6) \div 2 = 4\frac{1}{2}$ bricks, the height including one course of wall = 1' 9", which = $151' \times 1' 9'' \times (9 \text{ half-bricks} \div 3 \text{ half-bricks or } 3) = 792' 9''$ or 793' super of reduced work. To this will be added one of the bottom doubled courses which = $151' \times 3'' \times (12 \div 3 \text{ or } 4)$. This = 151' of reduced work, and together $793' + 151' = 944'$, or 3 rods 128'.

Brickwork is usually measured first as ordinary stock work,

length by height, the thickness stated, extra per foot super being allowed for facings; and all openings, arches, etc., deducted. It is usual to measure floor by floor, starting from the footings to the under side of the ground-floor joists, and so on.

Taking Fig. 212 as a guide, and supposing the quantities of the wall **AB** 15' in height, faced with red builders and pointed, with a weather joint, and containing the three 6' × 3' 6" window openings are required, the stock work will measure 50' × 15' 3 bricks thick $750' \times (6 \div 3)$ or $750' \times 2 = 1500'$ reduced work. But from this must be deducted $(3/3' 6'' \times 6') + (3/4' 3'' \times 6')$ $1\frac{1}{2}$ bricks thick = 139' 6". $1500' - 139' 6'' = 1362' 6''$, or 5 rods 2'.

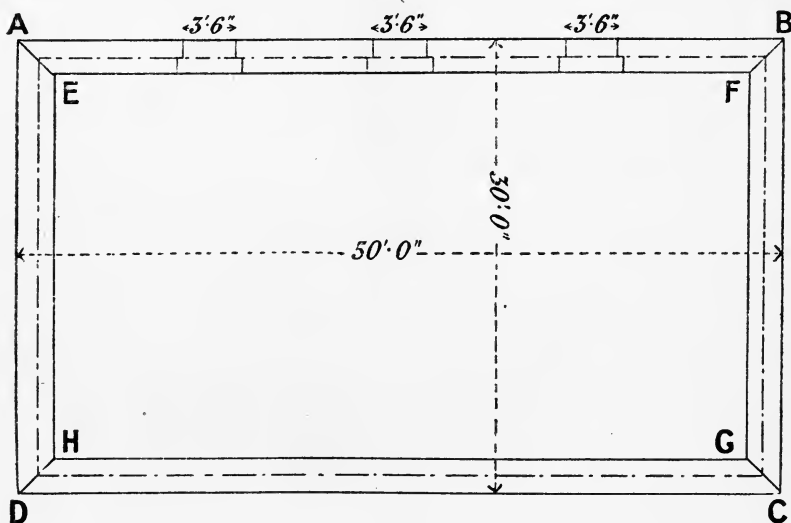

FIG. 212.

The extra for facings, including pointing, will be $50' \times 15'$ super, and added to this six reveals $6' \times 14''$, and three soffits of arches, say allowing for rise, $4' \times 14''$. From this again will be deducted the superficial measurement of the three window openings: $50' \times 15' = 750'$; $6/6' \times 1' 2'' = 42'$; $3/4' \times 1' 2'' = 6'$; together $750' + 42' + 6' = 798'$ super; deduct $3/6' \times 3' 6'' = 63'$ super; leaving $798' - 63'$, or 735' super.

Chimney Breasts.—Measure the width by the height, stating the thickness of the work; deduct the fireplace opening. The flues are taken in as if solid, pargeting to these being numbered. Ovens and coppers are also measured as solid, deducting the ash-hole only.

Arches.—The face and soffit are measured separately, and afterwards added. The camber arch (Fig. 156) will serve as an example for measuring. The opening being 3', but taking 12" as depth of face, add one skewback, making it 3' 3" \times 12" (depth of face), 3' \times 4 $\frac{1}{2}$ " soffit; the superficial measurement in this case will then be 4' 4 $\frac{1}{2}$ ".

For all radial arches, pass the tape round the face, midway between the intrados and extrados, arrive at the amount, and multiply by the depth of the face; then serve the soffit in a similar manner, multiplying by the depth.

Taking Fig. 148 as an example, the face is found to measure 3' 9" \times 12" = 3' 9", soffit 3' 2" \times 4 $\frac{1}{2}$ " = 1' 2", and together 4' 11".

The practical man sometimes finds a difficulty in multiplying by such awkward quantities as 6", 9", 4 $\frac{1}{2}$ "; but, by a little thinking, these become quite easy—

Feet multiplied by feet will give square feet, *e.g.* 12' \times 12' = 144'.

Feet multiplied by inches equal twelfths of feet; *e.g.* 20' \times 6" = 1 $\frac{2}{3}$ square feet; inches multiplied by inches equal square inches.

Feet multiplied by 6" will give half the amount multiplied, thus 12' \times 6" = 6' square.

Feet multiplied by 3" will give one quarter of the amount multiplied, 12' \times 3" = 3' square.

Feet multiplied by 9" will give the last two results combined, 12' \times 9" = ($\frac{1}{2}$ of 12) = 6 + ($\frac{1}{4}$ of 12) = 3; together 9' square.

Feet multiplied by 4 $\frac{1}{2}$ " will first be taken as the last, and half of that again taken, because 4 $\frac{1}{2}$ " is half of 9".

Feet multiplied by 2 $\frac{1}{4}$ " would be half the above, for the same reason.

Feet multiplied by 4" will give one-third of the amount multiplied, 4" being one-third of 12".

Feet multiplied by 8" will give twice the result of the last, 8" being two-thirds of 12".

To reduce cubic feet of brickwork to superficial feet of standard thickness, deduct one-ninth, *e.g.* 40' \times 20' three bricks thick = 1600' reduced work, compare with 40' \times 20' \times 2' 3" = 1800 cubic feet; take from this one-ninth of 1800', or 200', leaving 1600' reduced work as before.

Practical men usually take pointing by the square of 100' super.

To measure gables or pediments, take the central height by half the base for superficial measurement, and for brickwork according to the bricks thick.

To find the area of a circular opening, multiply the square of the diameter by 0·7854; *e.g.* diameter of circle, 10'—

$$10' \times 10' = 100' \times 0\cdot7854 = 78\cdot54$$

To measure fair cutting to a circle, multiply the diameter by 3·1416; *e.g.* diameter of circle, 10'—

$$10' \times 3\cdot1416 = 31\cdot416$$

For a semi-circular arch, half the above; *e.g.* diameter of semi-circular arch, including depth of face on each side = 10'. Fair cutting round the arch = 31·416 as above for the whole, $\div 2 = 15\cdot708$.

In measuring brickwork over 60' high from the ground, it should be kept separate, and divided into heights of 20', viz. 60 to 80, 80 to 100, etc. The reason for this is that the higher the work goes the more expensive it becomes to build.

Keep the following work separate:—

Brickwork built overhand.

Raising on old walls, stating the height the work commences from ground-level.

Circular brickwork.

Half-brick partition walls.

Sleeper walls.

Measure hollow walls as solid.

The following work is usually taken at the yard super: Lime-whiting; pointing when not included with the facings; brick-nogging, including timbers, stating if built flat or on edge; cement floated face, stating thickness, if to falls, and if floated or trowelled; all kinds of paving; wall tiling, giving full descriptions.

Work measured by the foot super: Damp-proof courses; trimmer arches; fender walls; sleeper walls; half-brick partition walls; arches generally, except gauged; facings, keeping the different kinds separate.

Work measured at per foot run: Cement filleting, cuttings under 6" wide, pointing flashings, cutting chases for pipes, brick on edge, and other kinds of copings.

Items numbered: Bed and point frames; setting stoves and ranges, fixing chimney pots, ventilating bricks, parget and core flues, rough relieving arches.

Hoop-iron bonding is measured at per yard run, adding 5 per cent. to the length for laps, stating if tarred and sanded, and making no deductions for openings.

SPECIFICATIONS

MATERIALS.

Bricks.—The (name the bricks to be used) to be good, sound, hard, well-burnt, square, true in shape, with sharp arrises and even surfaces, made equal to the sample to be submitted to, approved by, and deposited with, the architect.

Facings.—Face the (here state which portions) with Messrs. — first quality (here state the kind of bricks), a sample of which is to be approved by the architect.

Glazed Facings.—Face (here state where) with Messrs. — first quality (state colour) bricks.

Purpose made Moulded Bricks.—The moulded strings, cornices, etc., to be of (here state the maker and description), as shown on detail.

Rubbers or Cutters.—The bricks for all gauged arches, strings, cornices, pilasters, etc., where shown, to be of Messrs. — No. — first quality.

Lime Mortar.—To be composed of three parts clean sharp pit sand to one part of (name the lime), to be mixed and used the same day.

Cement Mortar.—The cement mortar to be composed of one part Portland cement of the best quality, well-burnt, weighing 112 lbs. per strike bushel, passed through a sieve of 2500 to the square inch without leaving more than 10 per cent. behind, and being capable of resisting a tensile strain of 350 lbs. per square inch after seven days' immersion in water, and three parts clean sharp pit sand, to be mixed with just sufficient water for their incorporation, and used immediately after mixing. No mortar that has partly set to be re-mixed for use.

Putty for Gauged Work.—The putty to be of chalk-lime mixed with water, and run through a fine sieve to the consistency of cream.

Note.—All other materials to be stated in a similar manner, the object being to ensure that the quality shall be quite up to the manufacturers' standard.

WORKMANSHIP.

Work generally.—The whole of the work to be carried up in (here state the bond) with mortar as specified, perfectly level, plumb, and true. The bricks to be well wetted before being used, each course to be properly flushed up, and no four courses of brick-work are to measure more than (here state the allowance for joint) in height, in addition to the collective height of the bricks, and no one portion being raised more than 5' above another at one time.

Footings.—The bottom course of footings to be twice the thickness of the wall to be built, setting off on each side in offsets of $2\frac{1}{4}$ " and to consist as far as possible of heading courses on each side.

Damp Courses.—The whole of the walls to have a layer of (here state the damp-resisting material), laid horizontally as a damp course 6" above ground-line, or where shown on drawings.

Facings.—The facings to be properly bonded with the general work, the beds and perpends to be kept perfectly true, and the joints (here state whether to be neatly struck or raked out and pointed, etc.), and all to be kept thoroughly clean.

Gauged Work generally.—All arches and embellishments where shown to be accurately rubbed and cut, and set in fine lime putty, the joint not to exceed $\frac{1}{32}$ " in thickness. The work, wherever possible, to be joggled and run in with Portland cement grout, and at completion to be cleaned down, leaving all mouldings, etc., perfectly true, and according to detail.

External Arches not Gauged.—The external arches to be formed with picked (here state the bricks), fair axed as shown, set in cement, and (here state the finish, *e.g.* struck or raked, etc.).

Relieving Arches.—Turn relieving arches over all lintels in (here state the number of rings) in cement, with skewbacks formed at the ends of the lintels and according to the given rise.

Chimney Openings, Flues, etc.—Build in over each fireplace opening a $\frac{1}{2}$ " \times $2\frac{1}{2}$ " wrought-iron caulked chimney bar, carried 9" each end into the jambs, and turned up and down 2" in addition. Turn a rough brick segmental arch over the same in two rings, and carefully gather over the opening to form the flue. The flues to be carried up the given size throughout, with no sharp curves

or bends, and to be properly pargeted as the work proceeds. Leave holes in the outside faces of the breasts where bends occur, so as to admit of cleaning out after execution, also render the whole of the chimney backs to fireplaces.

Sundries.—Do all rough and fair cutting.

Cut all holes through walls for pipes, and make good.

Bed and point all wood frames in lime and hair.

Bed all timbers on brickwork in mortar.

Cut away, etc., as required for other trades, and afterwards make good.

The above is not a complete specification ; many other items will occur according to the features of the work to be carried out, and must be specified in a similar manner.



USEFUL MEMORANDA, FROM VARIOUS SOURCES

A ROD of brickwork laid four courses to 12" requires 4360 stocks, and 71 cubic feet of mortar consisting of 1 yard of stone lime and $3\frac{1}{2}$ yards of sand.

The weight of a rod of brickwork is approximately 15 tons.

Facings per foot super require 7 bricks.

Reduced work per foot super, 16 bricks.

27 cubic feet, or 1 cubic yard, equals a single load of sand, earth, or rubbish.

2 cubic yards equal a double load.

A single load of bricks equals 500.

A measure of lime is 1 cubic yard, and equals 21 bushels.

A yard or load of sand equals 21 bushels.

A cubic yard of mortar requires 9 bushels of lime and 1 load of sand.

In estimating the quantity of water for making mortar, allow one-third of the total bulk.

London stocks measure $8\frac{3}{4}'' \times 4\frac{1}{4}'' \times 2\frac{3}{4}''$, and weigh $60\frac{3}{4}$ cwts. per thousand.

Earth and clay increase in bulk about one-fourth when dug; sand and gravel, one-tenth (Hirst).

33 cubic feet of ballast, $3\frac{1}{2}$ bushels of Portland cement, and 30 gallons of water make 1 cubic yard of concrete (Rivington).

The following weigh 1 ton: gravel, 19 cubic feet; river sand, 20 cubic feet; pit sand, 21 cubic feet; Thames ballast, 22 cubic feet; clean shingle, 23 cubic feet (Hirst).

1 cubic foot of water = 6.2355 gallons; 1 gallon of water weighs 10 lbs.; \therefore 1 cubic foot of water weighs 62.355 lbs.

In battering or retaining walls for earth, the base of the wall should not be less than one-fourth, and the batter, or slope, not less than one-sixth, the vertical height (Dobson).

Practical rule for thickness of walls to retain water—

Width at bottom equals height	× 0·7
" middle " "	× 0·5
" top " "	× 0·3 (Rivington).

Pillars of brick should, as a rule, be limited in height to twelve times their least thickness at the base to obtain their full strength.

A safe limit against crushing for best stock brickwork is as under—

Mortar, composed of Portland cement 1, sand 2	= 10 tons
" " Lias lime 1, sand 2	= 5 "
" " Grey stone lime 1, sand 2	= 3 "

The work to be flushed up solid with mortar (Hirst).

Ordinary firm earth will safely bear a pressure of 1 to 1½ ton per square foot, while moderately hard rock will bear as much as 9 tons (Rivington).

To find the area of an egg-shaped sewer, multiply the internal height squared by 0·525 as a constant (Rivington).

In reckoning the thickness of arches, the spans being from 10 to 25 feet, allow half a brick for every 5' of span (Rivington).

Efflorescence on walls is formed by a process known as salt-petring. In appearance it is like hoar-frost, and is caused by the sulphur in the coal used in burning, converting the lime or magnesia in the bricks or cement into sulphates. These, upon the application of water, are dissolved; after which, the water evaporating leaves them in the form of crystals on the surface.

Bricks burnt with coke or wood do not salt-petre.

Circles.—To find the area, square the diameter and multiply by 0·7854 or multiply the circumference by the diameter; and divide by 4. To find the circumference, multiply 3·1416 by the diameter.

The following tables show at a glance the thickness of walls for (1) dwelling-houses, (2) warehouses, as tabulated from the London Building Act by Hirst:—

1. DWELLING-HOUSES.

Height up to 120'	Length up to 45'	Length unlimited.
	One story, 30"	Top story, 13"
	Two stories, 26"	Remainder, add 4½" for
	Two stories, 21½"	each story
	Remainder, 13"	

Height up to 100'	Length up to 45'		Length unlimited.
	One story, 26" Two stories, 21 $\frac{1}{2}$ " Three stories, 17 $\frac{1}{2}$ " Remainder, 13"		One story, 30 $\frac{1}{2}$ " Two stories, 26" Two stories, 21 $\frac{1}{2}$ " Two stories, 17 $\frac{1}{2}$ " Remainder, 13"
Height up to 90'	Length up to 45'		Length unlimited.
	One story, 26" One story, 21 $\frac{1}{2}$ " Three stories, 17 $\frac{1}{2}$ " Remainder, 13"		One story, 30 $\frac{1}{2}$ " Two stories, 26" One story, 21 $\frac{1}{2}$ " Two stories, 17 $\frac{1}{2}$ " Remainder, 13"
Height up to 80'	Length up to 45'		Length unlimited.
	One story, 21 $\frac{1}{2}$ " Three stories, 17 $\frac{1}{2}$ " Remainder, 13"		One story, 26" Two stories, 21 $\frac{1}{2}$ " Two stories, 17 $\frac{1}{2}$ " Remainder, 13"
Height up to 70'	Length up to 45'		Length unlimited.
	One story, 21 $\frac{1}{2}$ " Two stories, 17 $\frac{1}{2}$ " Remainder, 13"		One story, 26" Two stories, 21 $\frac{1}{2}$ " One story, 17 $\frac{1}{2}$ " Remainder, 13"
Height up to 60'	Length up to 45'		Length unlimited.
	Two stories, 17 $\frac{1}{2}$ " Remainder, 13"		One story, 21 $\frac{1}{2}$ " Two stories, 17 $\frac{1}{2}$ " Remainder, 13"
Height up to 50'	Length up to 30'	Length up to 45'	Length unlimited.
	One story, 17 $\frac{1}{2}$ " Wall below the top story, 13" Remainder, 8 $\frac{1}{2}$ "	Two stories, 17 $\frac{1}{2}$ " Remainder, 13"	One story, 21 $\frac{1}{2}$ " One story, 17 $\frac{1}{2}$ " Remainder, 13"
Height up to 40'	Length up to 35'		Length unlimited.
	Wall below top story, 13" Top story, 8 $\frac{1}{2}$ "		One story, 17 $\frac{1}{2}$ " Rest of wall below top story, 13" Top story, 8 $\frac{1}{2}$ "

Height up to 30'	Length up to 35' Wall between two top stories, 13" Two top stories, 8½"	Length unlimited. Wall below top story, 13" Top story, 8½"
Height up to 25'	Length up to 30' From base to top of wall, 8½"	Length unlimited. Wall below top story, 13" Top story, 8½"

The above measurements are the minimum thicknesses.

2. WAREHOUSES.

Maximum height in feet.	Maximum length in feet.	Thickness at base in inches.	Maximum length in feet.	Thickness at base in inches.	Maximum length in feet.	Thickness at base in inches.
100	45	26	70	30	Length unlimited	31
90	45	26	70	30		34
80	45	21½	60	26		30
70	45	21½	—	—		26
60	45	21½	—	—		26
50	30	17½	45	21½		26
40	35	13	45	17½		21½
30	45	13	—	—		17½
25	—	—	—	—		13

GLOSSARY OF TERMS USED

- Abutment*, or *Springing*.—The pier or structure which receives the thrust of an arch or series of arches.
- Aggregate*.—Broken brick, ballast, or stone chippings, etc. : used in the preparation of concrete.
- Air-brick*.—A brick perforated with holes, and used for ventilating hollow walls, air-drains, etc.
- Air-drain*.—Usually a $2\frac{1}{4}$ " cavity in the external wall of a building, constructed below ground line as a protection from damp.
- Air-flue*.—A flue for admitting air to or from a room for the purpose of ventilation.
- Alumina*.—The principal constituent of a good brick earth, imparting the plastic qualities, though an excess causes the bricks to shrink and crack in burning.
- Architrave*.—The moulding round a window or door opening.
- Arris*.—The edge or external angle formed by the meeting of any two sides of a brick.
- Asphalte*.—A bituminous cement, solid at ordinary temperatures, but made liquid (of a viscous nature) by heating : used for road-making, and is an excellent damp-resisting material.
- Axed Arch*.—A brick arch in which the bricks are roughly cut or axed to the template.
- Back Hearth*.—That part of the hearth that is recessed for the stove.
- Barge Course*.—A course of bricks on edge on tile creasing.
- Bastard Tuck*.—Tuck pointing with mortar only, not finished with a white line.
- Bat*.—Half a brick cut so as to measure roughly $4\frac{1}{2}$ " \times $4\frac{1}{4}$ " \times $2\frac{3}{4}$ ". A three-quarter bat is $6\frac{3}{4}$ " long, or three-quarters of a stretcher.
- Batter*.—Walls built out of the perpendicular, and with the top falling in to resist earth pressure, water, etc.
- Bed*.—Setting work in mortar or cement. The under side of a brick is also known as the bed.
- Bed Joint*.—The horizontal joint between two courses.
- Bevel*.—(1) A tool (sometimes called a shift-stock) similar to a try square, but having a blade that can be set to any angle. (2) The splay cut on a brick to give the curve or sweep of an arch.
- Bird'smouth*.—An interior acute angle.
- Bonding Brick*.—A purpose made brick to tie the two parts of a hollow wall together.

Bow Saw.—A saw having twisted annealed wire instead of a blade, stretched by means of a bow.

Breeze.—Ashes, or fine cinders.

Burr.—Bricks vitrified or run together in burning.

Camber Arch.—An arch having a very slight rise.

Camber Slip.—A slip of wood for giving the rise to a camber arch.

Centre.—A temporary wooden structure used to support an arch while it is being constructed.

Chimney Bar.—An iron bar built over a fireplace opening upon which to turn the arch.

Chimney Breast.—The projecting wall, in which the flues and fireplaces are formed.

Chuffs.—Bricks that have cracked and split through sudden cooling, owing to rain falling on them while still hot.

Clamp Bricks.—Bricks burnt in a clamp or stack, distinct from kiln-burnt bricks.

Closer.—King closer; queen closer. A king closer is a brick cut to measure $2\frac{1}{4}'' \times 2\frac{3}{4}''$ on one face, and $4\frac{1}{2}'' \times 2\frac{3}{4}''$ on the other face; a queen closer is a brick cut down the centre, having both ends $2\frac{1}{4}'' \times 2\frac{3}{4}''$.

Concrete.—A mixture of ballast, broken brick, etc., and mortar.

Copperas.—The trade name for sulphate of iron.

Corbel.—A sailing over or projection from a wall to form a ledge or support.

Core.—(1) The brickwork filling in the space between the lintel and relieving arch. (2) Coring a flue is the process of cleaning it out after being built.

Cornice.—An overhanging moulding at or near the top of a wall.

Course.—A horizontal layer of bricks between two bed joints.

Creasing.—Either one or more courses of tiles or slates, built near the top of a wall and projecting slightly on both sides so as to protect the wall from rain, etc.

Crown.—The top of the extrados of an arch.

Cutter or Rubber.—A brick having a soft and even grain that can be cut or rubbed to any shape.

Damp-proof Course.—A course of asphalt, slates, lead, etc., placed just above ground line in order to prevent damp rising up the work.

Dentil.—One of the courses of a cornice, in which a block and sinking alternate.

Diagonal Bond.—Bricks laid at 45° with the face in the interior of a wall.

Discharging or Relieving Arch.—An arch built to discharge or distribute the weight of the superincumbent work over window and door openings.

Dry Area.—An area or hollow space left in the external wall of a building, the bottom of which is below the floor line, in order to keep the interior of the wall dry.

Dutch Arch.—An arch in which the bricks are laid in parallel courses, consequently forming an angle in the centre of the arch. This arch is sometimes called a French arch.

Dwarf Wall.—A low wall, usually between 2' and 3'.

Eaves Course.—A projecting course directly under the eaves of a roof.

Egg and Dart Moulding.—A moulding consisting of an egg and dart alternately.

Egg-shaped Sewer.—A sewer the section of which is similar in form to the curve of an egg, with the narrow end downwards.

- English Bond*.—Brickwork built in alternate courses of headers and stretchers.
- Extrados*.—The upper curved side of an arch.
- Face*.—The front or exposed surface of the work.
- Fat Lime*.—A lime burnt from a limestone composed of nearly pure carbonate of lime.
- Fender*.—A wall built round a basement fireplace opening for the purpose of carrying the hearth.
- Fillet*.—A small continuous moulding square in section. Also a screed of cement mortar used in inferior work instead of lead flashing.
- Fire-brick*.—A brick that will stand high temperatures: used in furnace work, lining coppers, etc.
- Flat Joint*.—A mortar joint finished flush with the face of the wall.
- Flat Joint Jointed*.—A similar joint to the above, but having an indentation marked on the edge with a tool called a jointer, similar to a letter S in shape, and having rounded edges.
- Flaunching*.—Weathering off the tops of chimney stacks with cement mortar.
- Flemish Bond*.—Double: a bond of brickwork having alternately a header and a stretcher in the same course, both faces of the wall being alike. Single: a similar bond to the above, but having Flemish bond on the face and English bond backing.
- Flue*.—A conduit for conveying smoke from a fire or furnace.
- Footings*.—The bottom courses of a wall, widened out so as to distribute the weight of the wall above over a large area, each course setting off $2\frac{1}{4}$ " each side of the wall.
- French Arch*.—See Dutch arch.
- Frog*.—An indentation given to a hand-made brick so as to form a key for the mortar.
- Front Hearth*.—That part of a hearth in front of the chimney breast.
- Gathering*.—The contraction of an opening (e.g. the flue over a fireplace opening) by corbelling over the bricks.
- Gauged Work*.—Brickwork built with bricks that have been rubbed to the exact shape and size required, and having a joint of $\frac{1}{8}$ ".
- Grout*.—Mortar made liquid, and used to fill up the joints in the interior of a wall.
- Hack*.—A hack is a long parallel bank in a brick field, raised about 6" above the surrounding land, upon which the bricks are stacked to dry.
- Header*.—The end view of a brick, $4\frac{1}{4}$ " \times $2\frac{3}{4}$ ".
- Heading Bond*.—Bond appearing as all headers upon face.
- Heading Course*.—A course of headers.
- Herring-bone Bond*.—A method of laying bricks in the interior of a wall, in which the cross joints run diagonally and converge towards the centre.
- Hollow Wall*.—A wall in which the interior is separated from the exterior by a hollow space. For walls in exposed positions, etc.
- Hoop-iron Bond*.—A wall in which hoop-iron, 2" wide by $\frac{1}{8}$ " thick, is laid between the bed joints in order to bind the wall together.
- Impost*.—A course of moulded bricks similar to the springing stone of an arch when it projects from the face of the wall or pier.
- Intrados*.—The under side or soffit of an arch.
- Jumb*.—The side of an opening in a wall.

Jointer.—A tool similar to a letter S in shape, having rounded edges, and used for jointing brickwork. Also a pointing tool for laying on putty.

Keene's Cement.—A cement produced by intimately mixing and burning plaster of Paris and alum.

Key Brick.—A stretcher immediately in the centre of an arch and towards the soffit.

Label.—A moulding running round an arch immediately over the extrados.

Lacing Course.—(1) A course of bricks built into a stone wall to act as a tie.

(2) A course of bricks built to a certain bond to tie together the rings of an arch.

Laggings.—Narrow strips of wood used to cover centering.

Larry.—A drag used in larrying up in thick walls, etc., and for mixing mortar.

Larrying up.—The method of laying bricks in thin mortar, covering the next course below so as to form their own cross-joints.

Lias Lime.—Lime made by burning limestone of the Lias formation : an hydraulic lime.

Lunette.—An arched opening in a vault or arched ceiling.

Malm Cutter.—A soft brick : used for arches.

Matrix.—The mortar into which the aggregate is mixed in making concrete.

Mortar-mill.—A mill for mixing mortar, consisting of an iron pan into which the ingredients are shot, which are then mixed by two iron rollers revolving in the pan.

Niche.—A recess formed in a wall for the purpose of receiving a statue or ornament.

Offset.—A reduction in a wall : the amount reduced is known as the offset.

Oriel Window.—An overhanging window on an upper floor.

Ovolo.—A convex moulding, usually a quadrant of a circle.

Parapet.—The upper part of an external wall carried above the roof, so as to form a gutter behind it.

Parge.—The material used for pargeting, composed of cow-dung and lime ; a non-conductor of heat.

Pargeting.—Covering the inside of a chimney flue with parge.

Party Wall.—The separating wall between two adjoining houses.

Pediment.—The name given in classical work to what in other styles would be called a gable.

Perpend.—The upright or cross joints in brickwork.

Pier.—(1) A four or more sided pillar. (2) The intermediate supports of bridges. (3) Brickwork between window openings, etc.

Pilaster.—A projection from a wall, usually rectangular on plan, to carry girders, etc.

Pit Sand.—Sand obtained from a pit, distinct from river or sea sand.

Place Brick.—A weak under-burnt brick.

Plaster of Paris.—A cement obtained by burning gypsum or alabaster.

Plinth.—A projecting base to a wall, etc.

Plinth Brick.—A purpose made brick, having a chamfer on the top edge, and suitable for the top course of a plinth.

Plumb.—Vertical.

Plumb-bob.—A weight, similar to a pear in shape, attached to a line to keep it vertical.

- Plumb-rule.*—A thin board, having a plumb-bob attached, used to ascertain whether a wall or structure is perfectly upright.
- Pointing.*—The process of raking out the mortar with which the bricks were laid, and refilling and jointing with specially prepared mortar.
- Poling Boards.*—Short pieces of board, usually about 3' long, and strutted in excavations to keep the sides from falling in.
- Poor Lime.*—A lime which contains a large per cent. of impurities, and therefore takes less sand than a pure lime.
- Portland Cement.*—An artificial cement, made from chalk and clay.
- Pressed Brick.*—A brick that has been firmly pressed in a mould before burning.
- Quicklime.*—Calcined limestone as it comes from the kiln, before being slaked.
- Quoin.*—The external angle of a wall.
- Radius.*—The distance from the centre to the circumference of a circle or segment.
- Raking.*—Anything sloping at an angle with the horizontal plane is said to be raking, or on the rake.
- Register Gate.*—A stove provided with a connecting door or plate between the flue and fireplace.
- Relieving Arch.*—See Discharging arch.
- Retaining Walls.*—See Batter for battering walls.
- Reveal.*—That part of the jamb of a window or door opening that is seen or revealed after the frame is fixed—between the face of the wall and the frame.
- Rich Lime.*—A fat or pure lime, burnt from limestone, composed of nearly pure CaCO_3 .
- Rise.*—The height of an arch from the springing line to the highest point of the intrados, or soffit.
- Roman Cement.*—An hydraulic cement, of a rich dark-brown colour, sets very quickly; made from the nodules found in the London Clay.
- Rough Arch.*—An arch in which the bricks are not cut, the joint radiating to give the desired curve.
- Rubber.*—A soft, even-grained brick, used for arches and gauged work.
- Rubbing Stone.*—A piece of flat bedded York stone, on which bricks are rubbed.
- Sag.*—An arch that has dropped in the centre is said to have sagged.
- Salt-glazed.*—Bricks that have been glazed by throwing salt on to them while burning.
- Scheme Arch.*—An arch which springs from a level bed, the springing line taking the place of the skewback.
- Segmental Arch.*—An arch in which the intrados is part of the circumference of a circle, less than half.
- Set-off.*—See Offset.
- Sheeting.*—Poling boards placed horizontally in excavating in loose ground, to keep the sides from falling in.
- Shippers.*—A good quality of stocks, used for export trade.
- Skew Arch.*—An arch formed over an opening at any angle other than a right angle.
- Skewback.*—The abutments receiving the thrusts of an arch.
- Slaked Lime.*—The product remaining after the chemical combination of quicklime and water.
- Soffit.*—The top of a door or window opening, the underside of an arch or flight of stairs.

- Soot Door*.—A small iron door in the side of a flue, whence it may be swept.
- Spandril*.—The triangular space at the haunch of an arch and immediately above the skewback.
- Springing Line*.—The horizontal line from which an arch springs or takes its rise.
- Squint*.—In quoins, where the angle is either obtuse or acute. A squint brick is a brick purposely made or cut to suit one of the above angles.
- Stock Brick*.—A clamp-burnt brick, of ordinary quality, used generally for building.
- Straight Arch*.—An arch with a soffit that has a slight camber.
- Stretcher*.—The 9" face of a brick.
- Stretching Bond*.—Bond consisting entirely of stretchers.
- Stretching Course*.—A course of stretchers.
- Struck Joint*.—A mortar joint in brickwork, in which the mortar used in laying the bricks forms the finished joint.
- Template, or Templet*.—A mould or pattern cut out of wood, to which arch bricks, etc., are cut.
- Tile Creasing*.—One or more courses of plain tiles laid underneath the coping of a wall, and projecting slightly on either side.
- Toothing*.—A series of projections or indentations left in a wall, so that, in the event of another wall being built against it, a proper tie or bond can be obtained between the two walls.
- Trammel*.—A rod used for setting out arches.
- Trimmer Arch*.—A brick arch for supporting the front hearth on an upper floor.
- Tuck Pointing*.—An artificial joint in brickwork, in which a narrow projecting fillet is inserted in each joint, of white or some specially coloured mortar, the work being supposed to represent gauged work.
- Turning Bar*.—See Chimney bar.
- Turning Piece*.—A piece of board cut to the intrados line of an arch, on which the arch is turned, when it is too small to require centring.
- Waling*.—A piece of timber used horizontally to support the poling boards in excavations.
- Wall Ties*.—These are of various shapes, usually 8" or 9" long, made of cast and wrought iron, having the ends turned down so as to form a better tie, and used in hollow walls, etc. They are sometimes galvanized, but more generally dipped in boiling tar.
- Washed Bricks*.—Bricks made from clay that has been specially prepared by washing.
- Withes*.—The 4½" brickwork parting two flues.

CITY AND GUILDS OF LONDON INSTITUTE.
TECHNOLOGICAL EXAMINATIONS.

Subject 57.—Brickwork.

SYLLABUS.

I. *Written Examination*.—The Examination will include questions founded upon such subjects as the following:—

ORDINARY GRADE.

1. Bricks.—The names, nature, and properties of the various kinds of bricks in general use, and the purposes for which each kind is specially fitted. The mode of preparing and tempering the clay, moulding and burning the bricks, and testing their quality.

2. Precautions to be adopted in excavations in various soils. Mode of laying drain-pipes.

3. Lime: nature and properties of the different kinds, and their use. Cement: method of making and means of testing. Sand: the relative advantages and disadvantages of pit, river, and sea sand. Proportions of the above for making good mortar. Concrete: its ingredients, method of preparation and uses.

4. Foundations.—The width and height of the footings required for walls of different thicknesses. Damp courses: the materials used for these, and their practical purpose. Air-bricks. The best method of ventilating under ground floors. Dry areas, and the method of constructing them and keeping them free from wet.

5. Bond in brickwork.—Plans of alternate courses at the angles of walls of different thicknesses, showing English and Flemish bond. Raking bond. Bond at acute and obtuse angles.

6. Brick walls with stone facings. Hollow walls: the methods of constructing and bonding them. Plans of openings in the same.

7. The method of constructing fireplaces, coppers, and ovens, and arrangement of flues. Bond of chimney shafts. Rendering, parging, and coring.

8. Arches.—Names of the different kinds and mode of construction. Bond in arches, and the description of their various parts, such as soffit, skewback, etc.

9. Paving, Pointing.—The comparative merits and demerits of various kinds. Proper composition of black mortar, etc.

10. Pan tiles, plain tiles, and the method of laying the same, and of finishing off the gables, hips, ridges, eaves, etc.

11. The general mechanical principles involved in brickwork, the resistance to crushing, and the average weight per foot cube and per rod.

12. Method of measuring brickwork, tiling, paving, concrete, etc., and the quantities of material required per rod, square, etc.

II. *Practical Work*.—Candidates who have passed in either grade of the Written Examination in brickwork may present themselves for a Practical Examination in that subject.

The Practical Examination will include the following work:—

1. Bricklaying.—(A) Setting out work from architectural drawings. The candidate must satisfy the Examiners of his ability to set out intricate work; *e.g.* frontages with awkward breaks, bay windows, and other openings; circular corners, square, obtuse, and acute external angles, irregular-shaped rooms, and intersection of walls, etc., first staking out the trenches, and then setting out the neat work.

(B) Building and properly finishing, either with struck or raked and pointed joint, as desired, any piece of work; *e.g.* quoins at any angle, circular corners afterwards brought out to the square, piers, battering walls, fireplaces, chimney shafts, coppers, etc., in red, stock, glazed, or other description of bricks.

2. Brick-cutting.—(A) Setting out work in detail from architectural drawings, and obtaining the templets, moulds, etc., *e.g.* arches moulded and plain, cornices, caps, pediments, pilasters, aprons, and gauged work generally.

(B) Cutting and finishing any required piece of gauged work from templets and moulds supplied.

TECHNOLOGICAL EXAMINATION, 1897.

WRITTEN EXAMINATION.

Instructions.

The candidate must confine himself to one grade only, the Ordinary or Honours, and must state, at the top of his paper of answers, which grade he has selected. He must *not* answer questions in more than one grade.

If he has already passed in the subject of "Brickwork" or "Brickwork and Masonry," in the first class of the Ordinary Grade, he must select his questions from those of the Honours Grade.

The number of the question must be placed before the answer in the worked paper.

A sheet of drawing paper is supplied to each candidate.

Drawing instruments to be used in this Examination.

Not more than *six* questions to be attempted in either grade.

The candidate is requested to state in what part of the country his experience has been acquired.

Three hours allowed for this paper.

The maximum number of marks obtainable is affixed to each question.

N.B.—*The answers ought to explain the matter in question quite fully and plainly, without being too long. Sketches, whether drawn freehand or with instruments, ought always to be made approximately to scale.*

ORDINARY GRADE.

1. Which is the stronger bond, English or Flemish? Prove your answers by sketches. (12)

2. Give a list of the constituents of brick earths, stating the action of each in brickmaking. (12)

3. Describe, either in words or by sketches, the meaning of the following terms: lacing-course, tile-creasing, brick-nogging, corbelling, and indent-tothing. (12)

4. The annexed diagram (Fig. 213) is the plan of a $2\frac{1}{2}$ -brick wall English bond, intersected by a $1\frac{1}{2}$ -brick wall single Flemish bond. Draw the alternate courses to a scale of $1\frac{1}{2}$ " to 1', showing Flemish bond at A. (14)

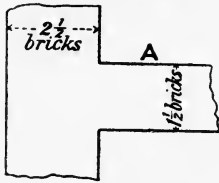

FIG. 213.

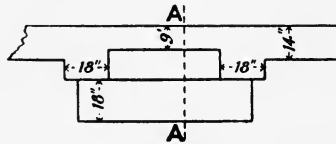

FIG. 214.

5. Plan of a fireplace in an upper room. Draw to a scale of 1" to 1' the section through A—A (Fig. 214), showing how the hearth is carried. (14)

6. Name some limes that might be classified under the following headings: feebly, ordinarily, and eminently hydraulic, saying for what purpose each lime would be best suited. (12)

7. Draw to a scale of $\frac{1}{12}$ a plan and cross-section of an inspection chamber for an ordinary dwelling-house, stating what steps you would take to make it water-tight. (14)

8. Draw the upper part of a 2' 6" window, showing moulded reveals, and a moulded segment arch 12" face, $4\frac{1}{2}$ " soffit, and 9" rise. Scale, $\frac{1}{8}$ full size. (14)

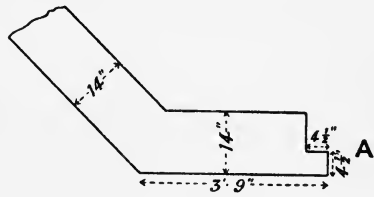

9. How are bricks salt-glazed and enamelled? For what purposes would each be used? (12)

10. Draw to a scale of 1" to 1' the elevation of a camber or straight arch, 14" on the face and 9" soffit, for a 3' opening. (14)

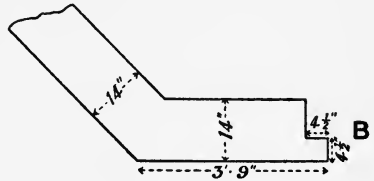

FIG. 215.

11. Taking the wall in No. 10 as 18" in thickness, draw to the same scale the elevation of a relieving arch, such as would be used behind the above, showing three $4\frac{1}{2}$ " brick rings, lintel and brick core, and stating the use of the two latter. (14)

12. Taking Nos. 10 and 11 in relation to each other, draw their section to a scale of $1\frac{1}{2}$ " to 1'. (12)

13. To a scale of $1\frac{1}{2}$ " to 1' fill in the annexed plans A and B (Fig. 215) with alternate courses of English bond; also give six courses in elevation. (18)

14. Draw to a scale of $\frac{1}{16}$ full size the alternate courses of a chimney stack, consisting of three flues, one 14" by 9", the other two 9" square; $4\frac{1}{2}$ " work only. (14)

1898.

ORDINARY GRADE.

1. A and B (Fig. 216) are plans of alternate courses of a $1\frac{1}{2}$ -brick wall English bond. Draw A to a scale of $\frac{1}{16}$, making any necessary alterations, and fill in the next course on B. (14)

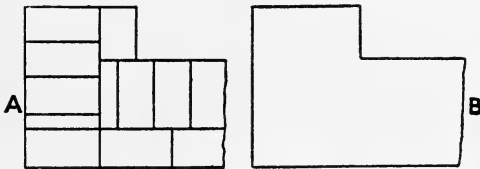

FIG. 216.

2. A $1\frac{1}{2}$ -brick wall is to be built in Flemish bond. Draw the section and part plan of its footings to a scale of $1''$ to $1'$. (14)

3. What is hydraulic lime? Where would you use it, and why? (12)

4. Give a description of the kind of sand you would use to mix with Portland cement. (12)

5. Draw to a scale of $\frac{1}{8}$ half the elevation of a moulded segment arch for a 3' opening. The moulding to be $2\frac{1}{4}''$, the face of arch $12''$, the rise $3''$, and the soffit $4\frac{1}{2}''$. Also show four top courses of the reveal and skewback in Flemish bond. (16)

6. Describe the manufacture of any brick with which you are acquainted. (12)

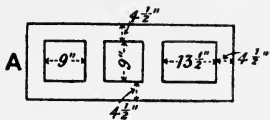

FIG. 217.

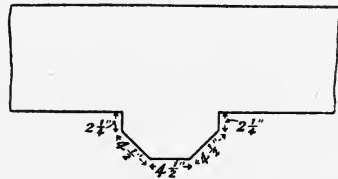

FIG. 218.

7. A (Fig. 217) is the plan of a chimney stack. Draw to a scale of $\frac{3}{4}''$ to $1'$ two successive courses in English bond. (14)

8. Give sketches of a corbel, string course, lacing course, and sailing course. (12)

9. Draw to a scale of $\frac{3}{4}''$ to $1'$ a section of an egg-shaped sewer, consisting of two $4\frac{1}{2}''$ brick rings, with a terra-cotta invert. Internal height 3'. (16)

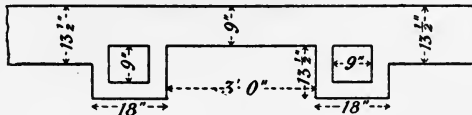

FIG. 219.

10. Show by sketches how wooden basement floors are carried, and the means you would adopt to prevent them suffering from dry rot. (14)

11. Annexed (Fig. 218) is the plan of a $1\frac{1}{2}$ -brick wall in English bond, with a gauged pilaster projecting from it. Draw the alternate courses to a scale of $\frac{1}{8}$. (16)

12. Plan of a fireplace (Fig. 219). To a scale of $1''$ to $1'$ draw the alternate courses, showing the bonding you would adopt. (14)

1899.

ORDINARY GRADE.

1. To a scale of $1\frac{1}{2}''$ to 1' draw plans of a $1\frac{1}{2}$ -brick wall at the square angle of a building. Double Flemish bond. (14)

2. Describe, and illustrate by sketches, how you would build a circular-fronted copper in the angle of a scullery. (14)

3. Draw to a 1'' scale the elevation of an equilateral or Gothic arch, 12'' on the face, for a 3' opening, showing in the one arch two ways of filling in. State which you think is the better way of the two, and why? (14)

4. A (Fig. 220) is the plan of one side of a window opening. Draw A, filling in the joints, and also the course above, to a scale of $1\frac{1}{4}''$ to 1'. English bond. (12)

5. A and B (Fig. 221) are successive courses of a $1\frac{1}{2}$ -brick wall, with Flemish bond at C, and English bond on the other side. Draw to a scale of $\frac{1}{12}$, showing how you would place the bricks. (14)

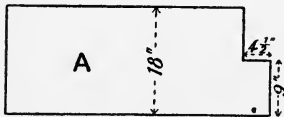

FIG. 220.

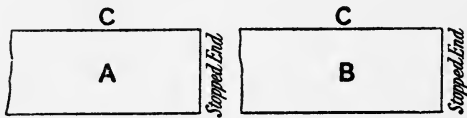

FIG. 221.

6. A wall is to be built of bricks, laid in lime mortar. Perfect workmanship being necessary, give a description of the materials, and state all that should be done in connection with the work to attain the desired end. (14)

7. What are transverse joints in brickwork? Would you prefer, for the sake of strength, that they should be broken or unbroken? Demonstrate your answer by sketches. (12)

8. To a scale of $\frac{3}{4}''$ to 1' draw the elevation of a plain segmental arch, 14'' on the face, for a 3' opening. The rise to be 12''. (12)

9. How many bricks, and how much lime and sand, are required in a reduced rod or $11\frac{1}{2}$ cubic yards of stock brickwork, the mortar consisting of three of sand to one of lime? What would be the approximate weight? (16)

10. What is the size of a plain tile, and what are valley and hip tiles? What is meant by gauge in tiling? Lap being given, how would you obtain the gauge? (12)

11. To the scale of 1'' to 1' draw the cross-section of a hollow wall 3' high, with its footings. The inside wall to be 9'', the cavity $2\frac{1}{4}''$, and the outside wall $4\frac{1}{2}''$, the two walls being connected by vitrified bonding bricks. Also show how you would provide for ventilation under the basement floor. Are there other modes of tying hollow walls? (16)

12. Draw the cross-section and part plan of footings for a 2-brick wall. No offset to be less than $2\frac{1}{4}''$. Scale $\frac{3}{4}''$ to 1'. (12)

1900.

ORDINARY GRADE.

1. At the square angle of a building, and to a scale of $1\frac{1}{2}''$ to 1', draw the successive courses a $1\frac{1}{2}$ -brick wall, with Flemish bond facing and English backing. (14)

2. Demonstrate fully by sketches which of the two bonds is the stronger, English or double Flemish. (12)

3. What is meant by "larrying up," "flushing up," and "grouting," in brickwork? In what special cases would each be used, and which do you consider the strongest for ordinary work? (12)

4. To a scale of $1\frac{1}{2}''$ to a foot draw the elevation of a plain camber arch, 12'' on the face, for a 3' opening. State what camber you would give the soffit, and the amount of skewback you would allow, giving the reason in each case. (16)

5. A and B (Fig. 222) are plans of successive courses of a basement fireplace. Fill in the bonding to a scale of $1\frac{1}{4}''$ to 1'. (16)

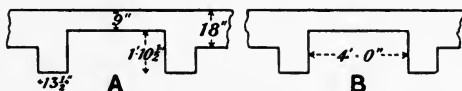

FIG. 222.

6. Taking the diagram A in the above question, and supposing the floor-level to be 2' 6'' above the concrete which covers the whole of the basement, show, to a scale of $\frac{1}{12}$, both on plan and section, how the front and back hearths are usually carried. (14)

7. How is Portland cement manufactured? and what are the usual tests for quality? (12)

8. Draw, full size, four ordinary mortar joints in brickwork. What is the difference between struck-joint work and pointed work? Give the advantages and disadvantages of each. (14)

9. Name four different bricks with which you are acquainted, and state, if samples of each were submitted to you, how you would test them for quality. (12)

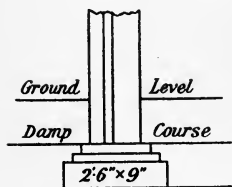

FIG. 223.

10. A 3' door opening is to be covered by a 3'' lintel and a relieving arch in three $4\frac{1}{2}''$ rings. Draw the elevation to a scale of 1'' to 1', giving the arch a 9'' rise. Does the lintel and core affect the strength of the arch? (14)

11. Show, both on plan and section, how you would timber for a trench 11' deep by 6' wide in running sand. Figure in the scantlings. (14)

12. The annexed diagram (Fig. 223) is the section of a hollow brick wall. Draw it, to a scale of $\frac{3}{4}''$ to 1', making any alterations you may deem necessary. Give detail sketches of as many ties as you know for bonding the $4\frac{1}{2}''$ with the 9'' work. Also show how you would ventilate under the wooden basement floor. (18)



INDEX

A

ABUTMENT, 55
Acute angles, 16
Adamantine clinkers, 95
Additions to old work, 36
Aggregate, 103
Air-drains, 23
Air-gratings, 26
Alumina, 88
Approximate key, 50
Arch, bull's-eye, 69
 —, camber, 57
 —, Gothic, 63
 —, horse-shoe, 71
 —, invert, 48
 — —, with moulded soffit, 54
 —, ogee, 71
 —, scheme, 69
 —, segment, 50
 —, semi-circular, 50
 —, semi-Gothic, 70
 —, setting, 54
Arches, adjacent, 72
 —, axed, 46-49
 —, centres for, 54
 —, circular, on plan, 61
 —, curving labels for, 76
 —, discharging, 47
 —, face bond of, 62
 —, filling in, 52
 —, gauged, 46-50
 —, labels for, 76
 —, plain, 46
 —, relieving, 47
 —, skewbacks for, 55
 —, templates for, 50
Architraves, 83
Area for egg-shaped sewer, 118
 — of circle, 118

Artificial colouring of bricks, 94
 — limes and cements, 97, 99
Ash-pit, 34
Automatic flushing tank, 43

B

Baked white lead, 86
Bastard tuck, 40
Bats, 4
Battering walls, 35
Bed joints, 4
 — of template, 52
Bedding timbers, 116
Bedding slate, 45
Bevel, 45
 — taking off, 52
Bird's-mouth brick, 16, 96
 — key, 64
Blocked keys, 87
Blue lias lime, 99
 — Staffords, 93, 94, 95
Boaster, or bolster, 45
Bond in brickwork, 9
 — for manholes, 41
Boss of niche, 74
Boundary walls, 22
Bow saw, 45
Boxes, lengthening, 46
 —, moulding, 46
 —, radiating, 46, 75
 —, reducing, 45
Brick burning, 92
 — core, 47
 — earths, 88
 — mould, 91
 — nogging, 37
 —, size of, 3
 — flat moulding, 78

Brick on edge moulding, 78
 — making, 90
 Brickwork measurements, 3, 106
 Bridge, 78
 Broken bond, 35
 — transverse joints, 11
 Building mortar, 104
 Bull-nosed bricks, 96
 Bull's-eye arch, 69
 Burrs, 96

C

Camber arch, 57
 — —, moulded, 60
 — —, skewback for, 58, 59
 — —, slip, 57
 — on circle arch, 61
 — —, curving bricks for, 62
 — —, development of, 61
 Carbonate of lime, 88, 97
 — of magnesia, 88, 97
 Carved work, 86
 Caustic lime, 97
 Cavity walls, 24
 Cements, 96
 Centres for arches, 54
 Chamber, disconnecting, 41
 Chimney bars, 29
 — bond, 31
 — breasts, 26
 — flues, 26
 — stacks, 31
 — —, height of, 32
 Chuffs, 96
 Circular corners, 22
 Circumference of circle, 118
 City and Guilds Examination Questions,
 128
 — — Syllabus, 127
 Clamp-burning, 92
 Clamps, 88
 Cleaning down, 40
 — — gauged work, 55
 Clip moulds for labels, 77
 Closer, king, 4
 —, queen, 4
 Club hammer, 45
 Cokebreeze lintels, 29
 Colouring of bricks, 94
 Compasses, 45
 Compo, 104
 Concrete, 7, 103

Concrete, proportions for, 103
 Coping bricks, 96
 Coppers, 34
 Corbelling, 30
 Coring holes, 30
 Cornices, 78
 —, moulded bricks for, 78
 Course, 3
 Cripple in arches, 65
 Cropped headers, 20
 Cross joints, 4
 — walls, 18
 Crowding kiln, 93
 Crown of arch, 49
 Cubing dimensions, 108
 Cupolas, 93
 Cutting away and making good, 116
 — bricks to length, 45, 46
 — mark, 52
 — semicircular niche, 73
 — shed, 45

D

Dampers, 33
 Damp-proof courses, 37
 Definitions, 1, 3
 Dentils, 81
 Diagonal bond, 10, 22
 Disconnecting chamber, 41
 — trap, 42
 Dividing short lines, 3
 Dorking lime, 99
 Dotting on, 109
 Double-breasted walls, 28
 Drain joints, 40
 — pipes, 40
 —, soil, 40
 Drains, fall of, 40
 —, iron, 43
 —, stoneware, 40
 —, ventilation of, 42
 Drainage, house, 40
 Dressed bricks, 94, 96
 Dry areas, 23
 — —, drainage of, 23
 — —, ventilation of, 23
 Duo-decimals, 107
 Dutch clinkers, 95
 Dwarf walls, 25

E

Efflorescence on walls, 118
 Egg-shaped sewer, 48
 Elevation, 1
 Ellipse—Gothic arch, 70
 Elliptical arch, 65
 — — —, compass method, 65
 — — —, filling in, 65
 — — —, fixed rise, 66
 — — —, master mould for, 67, 68
 — — — of stone and brick, 68
 — — —, string method, 66
 — — —, trammel method, 66
 — — niche, 76
 Encallowing, 90
 English bond, 10
 Equilateral arch, 63
 Examination Questions, 128
 Excavations, 5
 Expansion joints, 43
 Extrados, 50

F

Face bond of arches, 62
 Facings per foot super, 113, 117
 Fair cutting, 116
 Fareham reds, 95
 Fender walls, 25
 Field-moulded bricks, 57
 Filling in arches, 52
 — in mark, 51
 Fine stopping, 38
 Fire bricks, 95
 — ranges, close, 32
 Fireplace jambs, 28
 Fireplaces, 29
 Fixing or setting niche, 76
 Flat joint jointed, 39
 — jointing, 39
 Flemish bond, 10
 — — —, double, 10, 17
 — — —, single, 10, 19
 Flues, bend in, 28
 —, size of, 28
 Flushing up, 38
 — tank, automatic, 43
 Foot cube, 106
 — run, 106
 — super or square, 106
 Footings, 6, 8
 Foundations, 6

Frenchman, 39
 Frog, 91
 Frontage line, 5

G

Galvanized iron ties, 24
 Gannister bricks, 96
 Garden wall bond, 10, 21
 — — —, English, 10, 22
 — — —, Sussex, 10
 Gauged work, 45
 — — — joint, 39
 Gault bricks, 95
 Gin, 89
 Glazed or enamelled bricks, 95
 — salt, 95
 Gothic arch, 63
 Governing line, 12
 Grease-trap, 43
 Grey stocks, 94
 Grizzles, 96
 Grouting, 38
 Gun for skewbacks, 51

H

Hacks, 91
 Halling lime, 99
 Headers, 4
 Heading bond, 10, 22
 — courses, 8
 Hearths, back, 30
 —, front, 30
 —, mode of carrying, 29
 Herring-bone bond, 10, 22
 Hexagonal pilaster, 80
 Hoffmann's kiln, 93
 Hollow walls, 23
 Hoop-iron bond, 37
 Horse-shoe arch, 71
 House drainage, 40
 Hovel, 91
 Hydraulic limes, 98

I

Indent toothing, 36
 Inspection chambers, 41
 Internal angles, 11
 — mitres, 81
 Intersection of haunches, 72
 — of moulded soffit with moulded
 reveal, 56

Intrados, 50
 Invert arch, 48
 Iron in brick earths, 88

J

Jambs, 28
 Jennings' bonding bricks, 23
 Jogging, 55
 Joint upon joint, 11
 —, struck, 38
 —, weathered, 39
 Jointer, 39
 Jointing, 38
 —, flat, 39
 Joints, natural, 38
 Junctions of walls, 14

K

Keene's cement, 102
 Kerfs, 90
 Key-brick, 50
 Keys, projecting, 87
 Kick, 91
 Kilns, 88
 King closer, 4
 Kitcheners, 32
 —, American, 33
 —, double-oven, 33
 —, self-setting, 33

L

Labels for arches and niches, 76
 —, clip-mould for, 77
 Lacing courses, 10, 38
 Laggings, 29
 Lap, 4
 Larring-up, 38
 Laying down to scale, 2
 Leicestershire reds, 95
 Lengthening box, 46
 Lime in brickmaking, 88
 — kilns, 97
 Limes, 97
 Lining paper, 52
 Lintels, 29, 47
 Liquid shellac, 85, 86
 Live holes, 92
 Load of bricks, single, 117

Load of sand, single, 117
 Loam, 89
 London stocks, size of, 117
 — —, weight of, 117
 Long arm for fixing bricks, 78

M

Magnesia, 89
 Malm builders, 94
 — cutters, 89, 95
 — earth, 89
 — rubbers, 89
 Man-holes, 41
 —, bond for, 41
 —, rendering for, 41
 Mantel registers, 33
 Marls, 89
 Master mould for ellipse arch, 67
 Matrix, 103
 Measure of lime, 117
 Measurements, 2
 Measuring brickwork, etc., 106
 Method of curving arch labels, 77
 Mild clay, 89
 Mitre lines, 12
 Mode of carrying hearths, 29
 Modified Gothic, 64
 Moorish arch, 71
 Mop-staff beaded bricks, 57
 Mortar, 103
 —, colouring, 105
 —, mixing, 104
 —, pointing, 105
 Moulded camber arch, 60
 — reveals, 82
 — segment arch, 56
 — soffit to arch, 54
 — — to niche, 76
 Moulding boxes, 46
 — bricks, 91
 — — for cornices, 78
 Moulds for oriel window, 77

N

Natural joints, 38
 — limes and cements, 98
 Neat work, 8
 Niche, elliptical, 76
 —, label for, 76
 —, semicircular, 73

O

Obtuse angle, 16
 Octagonal pilaster, 80
 Offset, 8
 Ogee arch, 71
 Old work, additions to, 36
 Opposite bevells, 53
 Oriel window, 77
 — — —, courses equal in thickness, 77
 — — —, setting of, 78
 Oxide of iron, 94, 95

P

Pallet moulding, 91
 Panelling, 85
 Parallel file, 45
 Pargetting, 28
 Parian cement, 102
 Party walls, 26
 Paving, bond for, 23
 Pediments, 86
 Perforated gaults, 95
 Perpend, 4
 Pilasters, 79
 Pipes, drain, 40
 Pit sand, 102
 Place bricks, 96
 Plain arches, 46
 — ashlar, 46
 — facing, 46
 Plaiting walks, 91
 Plan, method of drawing, 1
 Plaster of Paris, 99
 Plastic clay, 89
 Plinth bricks, 96
 Plinths, 37
 Pointing, 39
 — mortar, 105
 Poling boards, 6
 Polished bricks, 96
 Poor lime, 98
 Portland cement, 99
 — — grouting, 55, 81
 — —, colour of, 101
 — —, manufacture of, 100
 — —, strength of, 101
 — —, tests for, 101
 — —, weight of, 101
 Pressed bricks, 94, 96
 Projecting keys, 87
 Protection of walls, 23

Protection by asphalt, 23
 — — — by cement, 23
 — — — by slating, 23
 Pugmill, 91
 Purpose made bricks, 96
 Putty box, 45
 — for pointing, 105
 — joints, 39, 55

Q

Quarter bond, 11
 — bonding line, 12
 Queen closer, 4
 Quick-lime, 97
 Quoin header, 12
 Quoins, 4

R

Radial joints, 48
 Radiated bricks, 96
 Radiating boxes, 46, 75
 Radius rod, 50
 Raking lines, 9
 — moulds, 86
 Recess, 14
 Red builders, 94
 Reduced work, 110
 Reducing boxes, 45
 — bricks to thickness, 46
 Register stoves, 33
 Relieving arch, 47
 Resistance of firm earth, 118
 Retaining walls, 35, 118
 Reveals, 14, 19
 —, moulded, 82
 Rich lime, 98
 River sand, 102
 Road drift, 102
 Rod of brickwork, number of stocks in,
 117
 — — —, quantity of mortar for, 117
 Roman cement, 99
 Rough arches, 46
 — cutting, 116
 Rubbers, 45
 —, T, L, B's, 95
 Rubbing stone, 45
 Rule for ring arches, 118
 Rules for bonding, 10, 11

S

- Safe limit against crushing for brick piers, 118
 Salt-glazed bricks, 95
 Sand in brickmaking, 88
 —, pit, 102
 —, river, 102
 —, sea, 102
 Scale, construction of, 2
 — rule, 1
 Scheme arch, 69
 Scotch, 45
 — kiln, 93
 Scribing saw, 45
 Section, 1
 Segment arch, 55
 Self-setting range, 33
 Semi-circular arch, 50
 — niche, 73
 — —, body of, 73
 — —, boss of, 74
 — —, fixing and setting, 76
 — —, hood of, 74
 — —, mode of cutting, 75
 Semi-Gothic arch, 70
 Setting kitcheners and close fire ranges, 32
 Setting of arches, 54
 — of limes, 97
 — out a building, 5
 — — board, 46
 — — square, 5
 — trowel, 45
 Settlement, 6
 Sewer, egg-shaped, 48
 Sheeting, 6
 Shellacing bricks, 85
 Shift stock, 52
 Shippers, 96
 Shoe moulds, 57
 Silica, 88
 Silicate of alumina, 88
 Skewback for camber arch, 58, 59
 — or abutment, 55
 Skewbacks for adjacent arches, 72
 Slacked lime, 97
 Slaking or slacking, 97
 Sleeper walls, 25
 Slop moulded, 91
 Slurry, 90
 Soda, 88
 Soffit, 51
 Soffit bond, 53
 Soil drains, 40
 — — fall of, 40
 Solid mitre, 81
 Specifications, 114
 Splayed jambs, 14
 Springing line, 50
 Square, 5, 45
 — angles, 16
 — piers, 14
 Squaring bricks, 46
 — dimensions, 107
 Squint bricks, 16, 96
 Staffordshire blues, 93, 94, 95
 Stages, 6
 Stock board, 91
 Stocks, 94, 96
 Stone corbels, 31
 — and brick arch, 68
 Stoneware drains, 40
 Stopped ends, 14
 — returns, 81
 Stopping, 39, 105
 Straight arch, 57
 — edges, 45
 Stretchers, 4
 Stretching bond, 10, 22
 Strike, 91
 String method for getting ellipse curve, 66
 Strong clay, 89
 Struck joints, 38
 Struts, 6
 Subsoil, 7
 Substitutes for sand, 102
 Superstructure, 6
 Sussex garden wall bond, 10
 — kiln, 93

T

- Table for thickness of walls for dwelling-houses, 118
 — — — for warehouses, 120
 Taking off from scale, 2
 Tee-irons, 30
 Tempering brick earths, 91
 Template, 50
 —, bed of, 52
 —, cutting side, 52
 —, traversing, 51
 — trial, 50

Terra-cotta invert, 49
 Tests for good bricks, 94
 Timbering for excavations, 5
 Timesing, 109
 Top bevel, 52, 60
 Toothings, 36
 Tracing, 13
 Trammel for ellipse, 66
 Transverse joints, 4
 — — —, broken, 11
 Traps, disconnecting, 42
 Trenches, 5
 Trimmer arch, 29
 True normals to ellipse curve, 68
 Tuck pointing, 39

U

Unequal settlement, 7
 Unsoiling, 90
 Useful memoranda, 117

V

Ventilation of drains, 42
 — to underground floors, 24
 Voussoirs, 68

W

Walings, 6
 Wall joints, 4
 Washing brick earths, 89
 Washmill, 89
 Water, measurement of, 117
 —, weight of, 117
 Weathered joints, 39
 Weight of bricks, 117
 — of clean shingle, 117
 — of gravel, 117
 — of pit sand, 117
 — of river sand, 117
 — of Thames ballast, 117
 White Suffolks, 95
 Withs, 31
 Working drawings, 5

Y

Yard of concrete, 117
 — of mortar, 117
 — of sand, 117
 Yellow stopping, 105



THE END.



A
 CLASSIFIED CATALOGUE
 OF
 SCIENTIFIC WORKS

PUBLISHED BY

MESSRS. LONGMANS, GREEN, & CO.

LONDON: 39 PATERNOSTER ROW, E.C.

NEW YORK: 91 & 93 FIFTH AVENUE.

BOMBAY: 32 HORNBY ROAD.

CONTENTS.

	PAGE		PAGE
<i>ADVANCED SCIENCE MANUALS</i>	- 30	MINERALOGY - - - -	- 14
AGRICULTURE - - - -	- 27	NATURAL HISTORY AND GENERAL	
ASTRONOMY - - - -	- 14	SCIENCE - - - -	- 17
BACTERIOLOGY - - - -	- 25	NAVAL ARCHITECTURE - - - -	- 13
BIOLOGY - - - -	- 25	NAVIGATION - - - -	- 14
BOTANY - - - -	- 26	OPTICS - - - -	- 8
BUILDING CONSTRUCTION - - - -	- 10	PHOTOGRAPHY - - - -	- 8
CHEMISTRY - - - -	- 2	PHYSICS - - - -	- 5
DYNAMICS - - - -	- 6	PHYSIOGRAPHY - - - -	- 16
ELECTRICITY - - - -	- 11	PHYSIOLOGY - - - -	- 25
<i>ELEMENTARY SCIENCE MANUALS</i>	- 30	<i>PRACTICAL ELEMENTARY SCIENCE</i>	
ENGINEERING - - - -	- 12	<i>SERIES</i> - - - -	- 32
GARDENING - - - -	- 27	<i>PROCTOR'S (R. A.) WORKS</i> - - - -	- 15
GEOLOGY - - - -	- 16	SOUND - - - -	- 8
HEALTH AND HYGIENE - - - -	- 18	STATICS - - - -	- 6
HEAT - - - -	- 8	STEAM, OIL, AND GAS ENGINES - - - -	- 9
HYDROSTATICS - - - -	- 6	STRENGTH OF MATERIALS - - - -	- 12
LIGHT - - - -	- 8	TECHNOLOGY - - - -	- 18
<i>LONDON SCIENCE CLASS-BOOKS</i>	- 32	TELEGRAPHY - - - -	- 12
<i>LONGMANS' CIVIL ENGINEERING</i>		TELEPHONE - - - -	- 12
<i>SERIES</i> - - - -	- 13	<i>TEXT-BOOKS OF SCIENCE</i> - - - -	- 29
MACHINE DRAWING AND DESIGN - - - -	- 13	THERMODYNAMICS - - - -	- 8
MAGNETISM - - - -	- 11	<i>TYNDALL'S (JOHN) WORKS</i> - - - -	- 28
MANUFACTURES - - - -	- 18	VETERINARY MEDICINE, ETC. - - - -	- 24
MECHANICS - - - -	- 6	WORKSHOP APPLIANCES - - - -	- 14
MEDICINE AND SURGERY - - - -	- 19	ZOOLOGY - - - -	- 25
METALLURGY - - - -	- 14		

CHEMISTRY.

CROOKES.—SELECT METHODS IN CHEMICAL ANALYSIS, chiefly Inorganic. By Sir WILLIAM CROOKES, F.R.S., etc. Third Edition, Rewritten and Enlarged. With 67 Woodcuts. 8vo., 21s. net.

FURNEAUX.—ELEMENTARY CHEMISTRY, Inorganic and Organic. By W. FURNEAUX, F.R.G.S., Lecturer on Chemistry, London School Board. With 65 Illustrations and 155 Experiments. Crown 8vo., 2s. 6d.

GARRETT AND HARDEN.—AN ELEMENTARY COURSE OF PRACTICAL ORGANIC CHEMISTRY. By F. C. GARRETT, M.Sc. (Vict. et Dunelm.), Assistant Lecturer and Demonstrator in Chemistry, the Durham College of Science, Newcastle-on-Tyne; and ARTHUR HARDEN, M.Sc. (Vict.), Ph.D., Assistant Lecturer and Demonstrator in Chemistry, the Owens College, Manchester. With 14 Illustrations. Crown 8vo., 2s.

JAGO.—Works by W. JAGO, F.C.S., F.I.C.

INORGANIC CHEMISTRY, THEORETICAL AND PRACTICAL. With an Introduction to the Principles of Chemical Analysis, Inorganic and Organic. With 63 Woodcuts and numerous Questions and Exercises. Fcp. 8vo., 2s. 6d.

AN INTRODUCTION TO PRACTICAL INORGANIC CHEMISTRY. Crown 8vo., 1s. 6d.

INORGANIC CHEMISTRY, THEORETICAL AND PRACTICAL. A Manual for Students in Advanced Classes of the Science and Art Department. With Plate of Spectra and 78 Woodcuts. Crown 8vo., 4s. 6d.

KOLBE.—A SHORT TEXT-BOOK OF INORGANIC CHEMISTRY. By Dr. HERMANN KOLBE. Translated and Edited by T. S. HUMPIDGE, Ph.D. With 66 Illustrations. Crown 8vo., 8s. 6d.

MENDELÉEFF.—THE PRINCIPLES OF CHEMISTRY. By D. MENDELÉEFF. Translated from the Russian (Sixth Edition) by GEORGE KAMENSKY, A.R.S.M., of the Imperial Mint, St. Petersburg; and Edited by T. A. LAWSON, B.Sc., Ph.D., Fellow of the Institute of Chemistry. With 96 Diagrams and Illustrations. 2 vols. 8vo., 36s.

MEYER.—OUTLINES OF THEORETICAL CHEMISTRY. By LOTHAR MEYER, Professor of Chemistry in the University of Tübingen. Translated by Professors P. PHILLIPS BEDSON, D.Sc., and W. CARLETON WILLIAMS, B.Sc. 8vo., 9s.

MILLER.—INTRODUCTION TO THE STUDY OF INORGANIC CHEMISTRY. By W. ALLEN MILLER, M.D., LL.D. With 71 Woodcuts. Fcp. 8vo., 3s. 6d.

CHEMISTRY—Continued.

MUIR.—A COURSE OF PRACTICAL CHEMISTRY. By M. P. MUIR, M.A., Fellow and Prælector in Chemistry of Gonville and Caius College, Cambridge. (3 Parts.)

Part I. Elementary. Crown 8vo., 4s. 6d.

Part II. Intermediate. Crown 8vo., 4s. 6d.

Part III. [In preparation.]

NEWTH.—Works by G. S. NEWTH, F.I.C., F.C.S., Demonstrator in the Royal College of Science, London.

CHEMICAL LECTURE EXPERIMENTS. With 230 Illustrations. Crown 8vo., 6s.

CHEMICAL ANALYSIS, QUANTITATIVE AND QUALITATIVE. With 100 Illustrations. Crown 8vo., 6s. 6d.

A TEXT-BOOK OF INORGANIC CHEMISTRY. With 146 Illustrations. Crown 8vo., 6s. 6d.

ELEMENTARY PRACTICAL CHEMISTRY. With 108 Illustrations and 254 Experiments. Crown 8vo., 2s. 6d.

OSTWALD.—SOLUTIONS. By W. OSTWALD, Professor of Chemistry in the University of Leipzig. Being the Fourth Book, with some additions, of the Second Edition of Oswald's 'Lehrbuch der allgemeinen Chemie'. Translated by M. M. PATTISON MUIR, Fellow and Prælector in Chemistry of Gonville and Caius College, Cambridge. 8vo., 10s. 6d.

PERKIN.—QUALITATIVE CHEMICAL ANALYSIS (ORGANIC AND INORGANIC). By F. MOLLWO PERKIN, Ph.D., Head of the Chemistry Department, Borough Polytechnic Institute, London. With 9 Illustrations and Spectrum Plate. 8vo., 3s. 6d.

REYNOLDS.—EXPERIMENTAL CHEMISTRY FOR JUNIOR STUDENTS. By J. EMERSON REYNOLDS, M.D., F.R.S., Professor of Chemistry, University of Dublin. Fcp. 8vo., with numerous Woodcuts.

Part I. Introductory. Fcp. 8vo., 1s. 6d.

Part II. Non-Metals, with an Appendix on Systematic Testing for Acids. Fcp. 8vo., 2s. 6d.

Part III. Metals, and Allied Bodies. Fcp. 8vo., 3s. 6d.

Part IV. Carbon Compounds. Fcp. 8vo., 4s.

SHENSTONE.—Works by W. A. SHENSTONE, F.R.S., Lecturer on Chemistry in Clifton College.

THE METHODS OF GLASS-BLOWING. For the use of Physical and Chemical Students. With 42 Illustrations. Crown 8vo., 1s. 6d.

A PRACTICAL INTRODUCTION TO CHEMISTRY. Intended to give a Practical acquaintance with the Elementary Facts and Principles of Chemistry. With 25 Illustrations. Crown 8vo., 2s.

CHEMISTRY—Continued.

THORNTON AND PEARSON.—NOTES ON VOLUMETRIC ANALYSIS. By ARTHUR THORNTON, M.A., and MERCHANT PEARSON, B.A., Assistant Science Master, Bradford Grammar School. Medium 8vo., 2s.

THORPE.—Works by T. E. THORPE, C.B., B.Sc. (Vict.), Ph.D., F.R.S., Professor of Chemistry in the Royal College of Science, South Kensington. Assisted by Eminent Contributors.

A DICTIONARY OF APPLIED CHEMISTRY. 3 vols. 8vo. Vols. I. and II., 42s. each. Vol. III., 63s.

QUANTITATIVE CHEMICAL ANALYSIS. With 88 Woodcuts. Fcp. 8vo., 4s. 6d.

THORPE AND MUIR.—QUALITATIVE CHEMICAL ANALYSIS AND LABORATORY PRACTICE. By T. E. THORPE, C.B., Ph.D., D.Sc., F.R.S., and M. M. PATTISON MUIR, M.A. With Plate of Spectra and 57 Woodcuts. Fcp. 8vo., 3s. 6d.

TILDEN.—Works by WILLIAM A. TILDEN, D.Sc. London, F.R.S., Professor of Chemistry in the Royal College of Science, South Kensington.

A SHORT HISTORY OF THE PROGRESS OF SCIENTIFIC CHEMISTRY IN OUR OWN TIMES. Crown 8vo., 5s. net.

INTRODUCTION TO THE STUDY OF CHEMICAL PHILOSOPHY. The Principles of Theoretical and Systematic Chemistry. With 5 Woodcuts. With or without the ANSWERS of Problems. Fcp. 8vo., 4s. 6d.

PRACTICAL CHEMISTRY. The principles of Qualitative Analysis. Fcp. 8vo., 1s. 6d.

HINTS ON THE TEACHING OF ELEMENTARY CHEMISTRY IN SCHOOLS AND SCIENCE CLASSES. With 7 Illustrations. Crown 8vo., 2s.

WATTS' DICTIONARY OF CHEMISTRY. Revised and entirely Rewritten by H. FORSTER MORLEY, M.A., D.Sc., Fellow of, and lately Assistant Professor of Chemistry in, University College, London; and M. M. PATTISON MUIR, M.A., F.R.S.E., Fellow, and Prælector in Chemistry, of Gonville and Caius College, Cambridge. Assisted by Eminent Contributors. 4 vols. 8vo., £5 net.

WHITELEY.—Works by R. LLOYD WHITELEY, F.I.C., Principal of the Municipal Science School, West Bromwich.

CHEMICAL CALCULATIONS. With Explanatory Notes, Problems and Answers, specially adapted for use in Colleges and Science Schools. With a Preface by Professor F. CLOWES, D.Sc. (Lond.), F.I.C. Crown 8vo., 2s.

ORGANIC CHEMISTRY: the Fatty Compounds. With 45 Illustrations. Crown 8vo., 3s. 6d.

PHYSICS, ETC.

GANOT.—Works by PROFESSOR GANOT. Translated and Edited by E. ATKINSON, Ph.D., F.C.S.

ELEMENTARY TREATISE ON PHYSICS, Experimental and Applied. With 9 Coloured Plates and Maps, and 1057 Woodcuts, and Appendix of Problems and Examples with Answers. Crown 8vo., 15s.

NATURAL PHILOSOPHY FOR GENERAL READERS AND YOUNG PEOPLE. Revised by A. W. REINOLD, M.A., F.R.S. With 7 Plates, 624 Woodcuts, and an Appendix of Questions. Crown 8vo., 7s. 6d.

GLAZEBROOK AND SHAW.—PRACTICAL PHYSICS. By R. T. GLAZEBROOK, M.A., F.R.S., and W. N. SHAW, M.A. With 134 Woodcuts. Fcp. 8vo., 7s. 6d.

GUTHRIE.—MOLECULAR PHYSICS AND SOUND. By F. GUTHRIE, Ph.D. With 91 Diagrams. Fcp. 8vo., 1s. 6d.

HELMHOLTZ.—POPULAR LECTURES ON SCIENTIFIC SUBJECTS. By HERMANN VON HELMHOLTZ. Translated by E. ATKINSON, Ph.D., F.C.S., formerly Professor of Experimental Science, Staff College. With 68 Illustrations. 2 vols., crown 8vo., 3s. 6d. each.

CONTENTS.—Vol. I.—The Relation of Natural Science to Science in General—Goethe's Scientific Researches—The Physiological Causes of Harmony in Music—Ice and Glaciers—The Interaction of the Natural Forces—The Recent Progress of the Theory of Vision—The Conservation of Force—The Aim and Progress of Physical Science.

CONTENTS.—Vol. II.—Gustav Magnus. In Memoriam—The Origin and Significance of Geometrical Axioms—The Relation of Optics to Painting—The Origin of the Planetary System—Thought in Medicine—Academic Freedom in German Universities—Hermann Von Helmholtz—An Autobiographical Sketch.

HENDERSON.—ELEMENTARY PHYSICS. By JOHN HENDERSON, D.Sc. (Edin.), A.I.E.E., Physics Department, Borough Road Polytechnic. Crown 8vo., 2s. 6d.

MACLEAN.—EXERCISES IN NATURAL PHILOSOPHY. By MAGNUS MACLEAN, D.Sc., Professor of Electrical Engineering at the Glasgow and West of Scotland Technical College. Crown 8vo., 4s. 6d.

MEYER.—THE KINETIC THEORY OF GASES. Elementary Treatise, with Mathematical Appendices. By Dr. OSKAR EMIL MEYER, Professor of Physics at the University of Breslau. Second Revised Edition. Translated by ROBERT E. BAYNES, M.A., Student of Christ Church, Oxford, and Dr. Lee's Reader in Physics. 8vo., 15s. net.

VAN 'THOFF.—THE ARRANGEMENT OF ATOMS IN SPACE. By J. H. VAN 'THOFF. Second, Revised, and Enlarged Edition. With a Preface by JOHANNES WISLICENUS, Professor of Chemistry at the University of Leipzig; and an Appendix 'Stereo-chemistry among Inorganic Substances,' by ALFRED WERNER, Professor of Chemistry at the University of Zürich. Translated and Edited by ARNOLD EILOART. Crown 8vo., 6s. 6d.

PHYSICS, ETC.—Continued.

WATSON.—Works by W. WATSON, F.R.S., B.Sc., Assistant Professor of Physics at the Royal College of Science, London; Assistant Examiner in Physics, Science and Art Department.

ELEMENTARY PRACTICAL PHYSICS: a Laboratory Manual for Use in Organised Science Schools. With 120 Illustrations and 193 Exercises. Crown 8vo., 2s. 6d.

A TEXT-BOOK OF PHYSICS. With 564 Diagrams and Illustrations. Large crown 8vo., 10s. 6d.

WORTHINGTON.—**A FIRST COURSE OF PHYSICAL LABORATORY PRACTICE.** Containing 264 Experiments. By A. M. WORTHINGTON, M.A., F.R.S. With Illustrations. Crown 8vo., 4s. 6d.

WRIGHT.—**ELEMENTARY PHYSICS.** By MARK R. WRIGHT, M.A., Professor of Normal Education, Durham College of Science. With 242 Illustrations. Crown 8vo., 2s. 6d.

MECHANICS, DYNAMICS, STATICS, HYDRO-STATICS, ETC.

BALL.—**A CLASS-BOOK OF MECHANICS.** By Sir R. S. BALL, LL.D. 89 Diagrams. Fcp. 8vo., 1s. 6d.

GELDARD.—**STATICS AND DYNAMICS.** By C. GELDARD, M.A., formerly Scholar of Trinity College, Cambridge. Crown 8vo., 5s.

GOODEVE.—Works by T. M. GOODEVE, M.A., formerly Professor of Mechanics at the Normal School of Science, and the Royal School of Mines.

THE ELEMENTS OF MECHANISM. With 357 Woodcuts. Crown 8vo., 6s.

PRINCIPLES OF MECHANICS. With 253 Woodcuts and numerous Examples. Crown 8vo., 6s.

A MANUAL OF MECHANICS: an Elementary Text-Book for Students of Applied Mechanics. With 138 Illustrations and Diagrams and 188 Examples taken from the Science Department Examination Papers, with Answers. Fcp. 8vo., 2s. 6d.

GOODMAN.—**MECHANICS APPLIED TO ENGINEERING.** By JOHN GOODMAN, Wh.Sch., A.M.I.C.E., M.I.M.E., Professor of Engineering in the Yorkshire College, Leeds (Victoria University). With 620 Illustrations and numerous examples. Crown 8vo., 7s. 6d. net.

GRIEVE.—**LESSONS IN ELEMENTARY MECHANICS.** By W. H. GRIEVE, late Engineer, R.N., Science Demonstrator for the London School Board, etc.

Stage 1. With 165 Illustrations and a large number of Examples. Fcp. 8vo., 1s. 6d.

Stage 2. With 122 Illustrations. Fcp. 8vo., 1s. 6d.

Stage 3. With 103 Illustrations. Fcp. 8vo., 1s.

MECHANICS, DYNAMICS, STATICS, HYDROSTATICS, ETC.—
Continued.

MAGNUS.—Works by SIR PHILIP MAGNUS, B.Sc., B.A.

LESSONS IN ELEMENTARY MECHANICS. Introductory to the study of Physical Science. Designed for the Use of Schools, and of Candidates for the London Matriculation and other Examinations. With numerous Exercises, Examples, Examination Questions, and Solutions, etc., from 1870-1895. With Answers, and 131 Woodcuts. Fcp. 8vo., 3s. 6d.

Key for the use of Teachers only, price 5s. 3½d.

HYDROSTATICS AND PNEUMATICS. Fcp. 8vo., 1s. 6d.; or, with Answers, 2s. The Worked Solutions of the Problems, 2s.

ROBINSON.—Works by the Rev. J. L. ROBINSON, M.A.

ELEMENTS OF DYNAMICS (Kinetics and Statics). With numerous Exercises. A Text-book for Junior Students. Crown 8vo., 6s.

A FIRST BOOK IN STATICS AND DYNAMICS. With numerous Examples and Answers. Crown 8vo, 3s. 6d.

Sold separately: Statics, 2s.; Dynamics, 2s.

SMITH.—Works by J. HAMBLIN SMITH, M.A.

ELEMENTARY STATICS. Crown 8vo., 3s.

ELEMENTARY HYDROSTATICS. Crown 8vo., 3s.

KEY TO STATICS AND HYDROSTATICS. Crown 8vo., 6s.

TARLETON.—AN INTRODUCTION TO THE MATHEMATICAL THEORY OF ATTRACTION. By FRANCIS A. TARLETON, LL.D., Sc.D., Fellow of Trinity College, and Professor of Natural Philosophy in the University of Dublin. Crown 8vo., 10s. 6d.

TAYLOR.—Works by J. E. TAYLOR, M.A., B.Sc. (Lond.).

THEORETICAL MECHANICS, including Hydrostatics and Pneumatics. With 175 Diagrams and Illustrations, and 522 Examination Questions and Answers. Crown 8vo., 2s. 6d.

THEORETICAL MECHANICS—SOLIDS. With 163 Illustrations, 120 Worked Examples and over 500 Examples from Examination Papers, etc. Crown 8vo., 2s. 6d.

THEORETICAL MECHANICS.—FLUIDS. With 122 Illustrations, numerous Worked Examples, and about 500 Examples from Examination Papers, etc. Crown 8vo., 2s. 6d.

THORNTON.—THEORETICAL MECHANICS—SOLIDS. Including Kinematics, Statics and Kinetics. By ARTHUR THORNTON, M.A., F.R.A.S. With 200 Illustrations, 130 Worked Examples, and over 900 Examples from Examination Papers, etc. Crown 8vo., 4s. 6d.

MECHANICS, DYNAMICS, STATICS, HYDROSTATICS, ETC.—

Continued.

TWISDEN.—Works by the Rev. JOHN F. TWISDEN, M.A.

PRACTICAL MECHANICS; an Elementary Introduction to their Study. With 855 Exercises, and 184 Figures and Diagrams. Crown 8vo., 10s. 6d.

THEORETICAL MECHANICS. With 172 Examples, numerous Exercises, and 154 Diagrams. Crown 8vo., 8s. 6d.

WILLIAMSON.—INTRODUCTION TO THE MATHEMATICAL THEORY OF THE STRESS AND STRAIN OF ELASTIC SOLIDS. By BENJAMIN WILLIAMSON, D.Sc., F.R.S. Crown 8vo., 5s.

WILLIAMSON AND TARLETON.—AN ELEMENTARY TREATISE ON DYNAMICS. Containing Applications to Thermodynamics, with numerous Examples. By BENJAMIN WILLIAMSON, D.Sc., F.R.S., and FRANCIS A. TARLETON, LL.D. Crown 8vo., 10s. 6d.

WORTHINGTON.—DYNAMICS OF ROTATION: an Elementary Introduction to Rigid Dynamics. By A. M. WORTHINGTON, M.A., F.R.S. Crown 8vo., 4s. 6d.

OPTICS AND PHOTOGRAPHY.

ABNEY.—A TREATISE ON PHOTOGRAPHY. By Sir WILLIAM DE WIVELESLE ABNEY, K.C.B., F.R.S., Principal Assistant Secretary of the Secondary Department of the Board of Education.

GLAZEBROOK.—PHYSICAL OPTICS. By R. T. GLAZEBROOK, M.A., F.R.S., Principal of University College, Liverpool. With 183 Woodcuts of Apparatus, etc. Fcp. 8vo., 6s.

WRIGHT.—OPTICAL PROJECTION: a Treatise on the Use of the Lantern in Exhibition and Scientific Demonstration. By LEWIS WRIGHT, Author of 'Light: a Course of Experimental Optics'. With 232 Illustrations. Crown 8vo., 6s.

SOUND, LIGHT, HEAT, AND THERMODYNAMICS.

CUMMING.—HEAT TREATED EXPERIMENTALLY. By LINNÆUS CUMMING, M.A. With 192 Illustrations. Crown 8vo., 4s. 6d.

DAY.—NUMERICAL EXAMPLES IN HEAT. By R. E. DAY, M.A. Fcp. 8vo., 3s. 6d.

SOUND, LIGHT, HEAT, AND THERMODYNAMICS—Continued.

EMTAGE.—LIGHT. By W. T. A. EMTAGE, M.A., Director of Education, Mauritius. With 232 Illustrations. Crown 8vo., 6s.

HELMHOLTZ.—ON THE SENSATIONS OF TONE AS A PHYSIOLOGICAL BASIS FOR THE THEORY OF MUSIC. By HERMANN VON HELMHOLTZ. Royal 8vo., 28s.

MADAN.—AN ELEMENTARY TEXT-BOOK ON HEAT. For the Use of Schools. By H. G. MADAN, M.A., F.C.S., Fellow of Queen's College, Oxford; late Assistant Master at Eton College. Crown 8vo., 9s.

MAXWELL.—THEORY OF HEAT. By J. CLERK MAXWELL M.A., F.R.SS., L. and E. With Corrections and Additions by Lord RAY LEIGH. With 38 Illustrations. Fcp. 8vo., 4s. 6d.

SMITH.—THE STUDY OF HEAT. By J. HAMBLIN SMITH, M.A., of Gonville and Caius College, Cambridge. Crown 8vo., 3s.

TYNDALL.—Works by JOHN TYNDALL, D.C.L., F.R.S.
See p. 28.

WORMELL.—A CLASS-BOOK OF THERMODYNAMICS. By RICHARD WORMELL, B.Sc., M.A. Fcp. 8vo., 1s. 6d.

WRIGHT.—Works by MARK R. WRIGHT, M.A.

SOUND, LIGHT, AND HEAT. With 160 Diagrams and Illustrations. Crown 8vo., 2s. 6d.

ADVANCED HEAT. With 136 Diagrams and numerous Examples and Examination Papers. Crown 8vo., 4s. 6d.

STEAM, OIL, AND GAS ENGINES.

BALE.—A HAND-BOOK FOR STEAM USERS; being Rules for Engine Drivers and Boiler Attendants, with Notes on Steam Engine and Boiler Management and Steam Boiler Explosions. By M. POWIS BALE, M.I.M.E., A.M.I.C.E. Fcp. 8vo., 2s. 6d.

CLERK.—THE GAS AND OIL ENGINE. By DUGALD CLERK, Member of the Institution of Civil Engineers, Fellow of the Chemical Society, Member of the Royal Institution, Fellow of the Institute of Patent Agents. With 228 Illustrations. 8vo., 15s.

HOLMES.—THE STEAM ENGINE. By GEORGE C. V. HOLMES, Chairman of the Board of Works, Ireland. With 212 Woodcuts. Fcp. 8vo., 6s.

STEAM, OIL, AND GAS ENGINES—Continued.

NORRIS.—A PRACTICAL TREATISE ON THE 'OTTO' CYCLE GAS ENGINE. By WILLIAM NORRIS, M.I.Mech.E. With 207 Illustrations. 8vo., 10s. 6d.

RIPPER.—Works by WILLIAM RIPPER, Professor of Mechanical Engineering in the Sheffield Technical School.

STEAM. With 142 Illustrations. Crown 8vo., 2s. 6d.

STEAM ENGINE THEORY AND PRACTICE. With 438 Illustrations. 8vo., 9s.

SENNETT AND ORAM.—THE MARINE STEAM ENGINE : A Treatise for Engineering Students, Young Engineers and Officers of the Royal Navy and Mercantile Marine. By the late RICHARD SENNETT, Engineer-in-Chief of the Navy, etc. ; and HENRY J. ORAM, Senior Engineer Inspector at the Admiralty, Inspector of Machinery in H.M. Fleet, etc. With 414 Diagrams. 8vo., 21s.

STROMEYER.—MARINE BOILER MANAGEMENT AND CONSTRUCTION. Being a Treatise on Boiler Troubles and Repairs, Corrosion, Fuels, and Heat, on the properties of Iron and Steel, on Boiler Mechanics, Workshop Practices, and Boiler Design. By C. E. STROMEYER, Chief Engineer of the Manchester Steam Users' Association, Member of Council of the Institution of Naval Architects, etc. With 452 Diagrams, etc. 8vo., 12s. net.

BUILDING CONSTRUCTION.

ADVANCED BUILDING CONSTRUCTION. By the Author of 'Rivingtons' Notes on Building Construction'. With 385 Illustrations. Crown 8vo., 4s. 6d.

BURRELL.—BUILDING CONSTRUCTION. By EDWARD J. BURRELL, Second Master of the People's Palace Technical School, London. With 303 Working Drawings. Crown 8vo., 2s. 6d.

SEDDON.—BUILDER'S WORK AND THE BUILDING TRADES. By Col. H. C. SEDDON, R.E., late Superintending Engineer, H.M.'s Dockyard, Portsmouth; Examiner in Building Construction, Science and Art Department, South Kensington. With numerous Illustrations. Medium 8vo., 16s.

RIVINGTONS' COURSE OF BUILDING CONSTRUCTION.

NOTES ON BUILDING CONSTRUCTION. Arranged to meet the requirements of the syllabus of the Board of Education. Medium 8vo.

Part I. Elementary Stage. With 552 Illustrations, 10s. 6d.

Part II. Advanced Stage. With 479 Illustrations, 10s. 6d.

Part III. Materials. Course for Honours. With 188 Illustrations, 21s.

Part IV. Calculations for Building Structures. Course for Honours. With 597 Illustrations, 15s.

ELECTRICITY AND MAGNETISM.

- CARUS-WILSON.**—ELECTRO-DYNAMICS: the Direct-Current Motor. By CHARLES ASHLEY CARUS-WILSON, M.A. Cantab. With 71 Diagrams, and a Series of Problems, with Answers. Crown 8vo., 7s. 6d.
- CUMMING.**—ELECTRICITY TREATED EXPERIMENTALLY. By LINNÆUS CUMMING, M.A. With 242 Illustrations. Cr. 8vo., 4s. 6d.
- DAY.**—EXERCISES IN ELECTRICAL AND MAGNETIC MEASUREMENTS, with Answers. By R. E. DAY. 12mo., 3s. 6d.
- GORE.**—THE ART OF ELECTRO-METALLURGY, including all known Processes of Electro-Deposition. By G. GORE, LL.D., F.R.S. With 56 Woodcuts. Fcp. 8vo., 6s.
- HENDERSON.**—Works by JOHN HENDERSON, D.Sc., F.R.S.E. PRACTICAL ELECTRICITY AND MAGNETISM. With 159 Illustrations and Diagrams. Crown 8vo., 6s. 6d. PRELIMINARY PRACTICAL MAGNETISM AND ELECTRICITY: A Text-book for Organised Science Schools and Elementary Evening Science Schools. Crown 8vo., 1s.
- JENKIN.**—ELECTRICITY AND MAGNETISM. By FLEEMING JENKIN, F.R.S., M.I.C.E. With 177 Illustrations. Fcp. 8vo., 3s. 6d.
- JOUBERT.**—ELEMENTARY TREATISE ON ELECTRICITY AND MAGNETISM. By G. C. FOSTER, F.R.S., and E. ATKINSON, Ph.D. With 381 Illustrations. Crown 8vo., 7s. 6d.
- JOYCE.**—EXAMPLES IN ELECTRICAL ENGINEERING. By SAMUEL JOYCE, A.I.E.E. Crown 8vo., 5s.
- LARDEN.**—ELECTRICITY FOR PUBLIC SCHOOLS AND COLLEGES. By W. LARDEN, M.A. With 215 Illustrations. Cr. 8vo., 6s.
- MACLEAN AND MARCHANT.**—ELEMENTARY QUESTIONS IN ELECTRICITY AND MAGNETISM. With Answers. Compiled by MAGNUS MACLEAN, D.Sc., M.I.E.E., and E. W. MARCHANT, D.Sc., A.I.E.E. Crown 8vo., 1s.
- MERRIFIELD.**—MAGNETISM AND DEVIATION OF THE COMPASS. By JOHN MERRIFIELD, LL.D., F.R.A.S., 18mo., 2s. 6d.
- PARR.**—PRACTICAL ELECTRICAL TESTING IN PHYSICS AND ELECTRICAL ENGINEERING: being a Course suitable for First and Second Year Students and others. By G. D. ASPINALL PARR, Assoc. M.I.E.E. With 231 Illustrations. 8vo., 8s. 6d.
- POYSER.**—Works by A. W. POYSER, M.A. MAGNETISM AND ELECTRICITY. With 235 Illustrations. Crown 8vo., 2s. 6d. ADVANCED ELECTRICITY AND MAGNETISM. With 317 Illustrations. Crown 8vo., 4s. 6d.
- SLINGO AND BROOKER.**—Works by W. SLINGO and A. BROOKER. ELECTRICAL ENGINEERING FOR ELECTRIC LIGHT ARTISANS AND STUDENTS. With 371 Illustrations. Crown 8vo., 12s. PROBLEMS AND SOLUTIONS IN ELEMENTARY ELECTRICITY AND MAGNETISM. With 98 Illustrations. Cr. 8vo., 2s.
- TYNDALL.**—Works by JOHN TYNDALL, D.C.L., F.R.S. See p. 28.

TELEGRAPHY AND THE TELEPHONE.

HOPKINS.—Works by WILLIAM J. HOPKINS, Professor of Physics in the Drexel Institute, Philadelphia.

THE TELEPHONE: Outlines of the Development of Transmitters and Receivers. With 7 Full-page Illustrations and 39 Diagrams. Crown 8vo., 3s. 6d.

TELEPHONE LINES AND THEIR PROPERTIES. Crown 8vo., 6s.

PREECE AND SIVEWRIGHT.—TELEGRAPHY. By Sir W. H. PREECE, K.C.B., F.R.S., V.P.Inst., C.E., etc., Engineer-in-Chief and Electrician, Post Office Telegraphs; and Sir J. SIVEWRIGHT, K.C.M.G., General Manager, South African Telegraphs. With 267 Illustrations. Fcp. 8vo., 6s.

ENGINEERING, STRENGTH OF MATERIALS, ETC.

ANDERSON.—THE STRENGTH OF MATERIALS AND STRUCTURES: the Strength of Materials as depending on their Quality and as ascertained by Testing Apparatus. By Sir J. ANDERSON, C.E., LL.D., F.R.S.E. With 66 Woodcuts. Fcp. 8vo., 3s. 6d.

BARRY.—RAILWAY APPLIANCES: a Description of Details of Railway Construction subsequent to the completion of the Earthworks and Structures. By Sir JOHN WOLFE BARRY, K.C.B., F.R.S., M.I.C.E. With 218 Woodcuts. Fcp. 8vo., 4s. 6d.

GOODMAN.—MECHANICS APPLIED TO ENGINEERING. By JOHN GOODMAN, Wh.Sch., A.M.I.C.E., M.I.M.E., Professor of Engineering in the Yorkshire College, Leeds (Victoria University). With 620 Illustrations and numerous Examples. Crown 8vo., 7s. 6d. net.

LOW.—A POCKET-BOOK FOR MECHANICAL ENGINEERS. By DAVID ALLAN LOW (Whitworth Scholar), M.I.Mech.E., Professor of Engineering, East London Technical College (People's Palace), London. With over 1000 specially prepared Illustrations. Fcp. 8vo., gilt edges, rounded corners, 7s. 6d.

SMITH.—GRAPHICS, or the Art of Calculation by Drawing Lines, applied especially to Mechanical Engineering. By ROBERT H. SMITH, Professor of Engineering, Mason College, Birmingham. Part I. With separate Atlas of 29 Plates containing 97 Diagrams. 8vo., 15s.

STONEY.—THE THEORY OF STRESSES IN GIRDERS AND SIMILAR STRUCTURES; with Practical Observations on the Strength and other Properties of Materials. By BINDON B. STONEY, LL.D., F.R.S., M.I.C.E. With 5 Plates and 143 Illust. in the Text. Royal 8vo., 36s.

UNWIN.—Works by W. CAWTHORNE UNWIN, F.R.S., B.S.c.
THE TESTING OF MATERIALS OF CONSTRUCTION.
A Text-book for the Engineering Laboratory and a Collection of the Results of Experiment. With 5 Plates and 188 Illustrations and Diagrams in the Text. 8vo., 16s. net.

ON THE DEVELOPMENT AND TRANSMISSION OF POWER FROM CENTRAL STATIONS: being the Howard Lectures delivered at the Society of Arts in 1893. With 81 Diagrams. 8vo., 10s. net.

WARREN.—ENGINEERING CONSTRUCTION IN IRON, STEEL, AND TIMBER. By WILLIAM HENRY WARREN, Challis Professor of Civil and Mechanical Engineering, University of Sydney. With 13 Folding Plates and 375 Diagrams. Royal 8vo., 16s. net.

LONGMANS' CIVIL ENGINEERING SERIES.

Edited by the Author of 'Notes on Building Construction'.

- NOTES ON DOCKS AND DOCK CONSTRUCTION.** By C. COLSON, M.Inst.C.E., Deputy Civil Engineer-in-Chief, Admiralty. With 365 Illustrations. Medium 8vo., 21s. net.
- CALCULATIONS IN HYDRAULIC ENGINEERING:** a Practical Text-Book for the use of Students, Draughtsmen and Engineers. By T. CLAXTON FIDLER, M.Inst.C.E., Professor of Engineering, University College, Dundee.
- Part I. Fluid Pressure and the Calculation of its Effects in Engineering Structures. With numerous Illustrations and Examples. 8vo., 6s. 6d. net.
- RAILWAY CONSTRUCTION.** By W. H. MILLS, M.I.C.E., Engineer-in-Chief of the Great Northern Railway of Ireland. With 516 Illustrations and Diagrams. 8vo., 18s. net.
- PRINCIPLES AND PRACTICE OF HARBOUR CONSTRUCTION.** By WILLIAM SHIELD, F.R.S.E., M.Inst.C.E., and Executive Engineer, National Harbour of Refuge, Peterhead, N.B. With 97 Illustrations. Medium 8vo., 15s. net.
- TIDAL RIVERS:** their (1) Hydraulics, (2) Improvement, (3) Navigation. By W. H. WHEELER, M.Inst.C.E. With 75 Illustrations. Medium 8vo., 16s. net.

NAVAL ARCHITECTURE.

- ATTWOOD.**—TEXT-BOOK OF THEORETICAL NAVAL ARCHITECTURE: a Manual for Students of Science Classes and Draughtsmen Engaged in Shipbuilders' and Naval Architects' Drawing Offices. By EDWARD LEWIS ATTWOOD, Assistant Constructor, Royal Navy; Member of the Institution of Naval Architects. With 114 Diagrams. Crown 8vo., 7s. 6d.
- WATSON.**—NAVAL ARCHITECTURE: A Manual of Laying-off Iron, Steel and Composite Vessels. By THOMAS H. WATSON, Lecturer on Naval Architecture at the Durham College of Science, Newcastle-upon-Tyne. With numerous Illustrations. Royal 8vo., 15s. net.

MACHINE DRAWING AND DESIGN.

- LOW.**—Works by DAVID ALLAN LOW, Professor of Engineering, East London Technical College (People's Palace).
- IMPROVED DRAWING SCALES. 6d. in case.
- AN INTRODUCTION TO MACHINE DRAWING AND DESIGN. With 153 Illustrations and Diagrams. Crown 8vo., 2s. 6d.
- LOW AND BEVIS.**—A MANUAL OF MACHINE DRAWING AND DESIGN. By DAVID ALLAN LOW and ALFRED WILLIAM BEVIS, M.I.Mech.E. With 700 Illustrations. 8vo., 7s. 6d.
- UNWIN.**—THE ELEMENTS OF MACHINE DESIGN. By W. CAWTHORNE UNWIN, F.R.S.
- Part I. General Principles, Fastenings, and Transmissive Machinery. With 345 Diagrams, etc. Fcp. 8vo., 7s. 6d.
- Part II. Chiefly on Engine Details. With 174 Woodcuts. Fcp. 8vo., 4s. 6d.

WORKSHOP APPLIANCES, ETC.

NORTHCOTT.—LATHES AND TURNING, Simple, Mechanical and Ornamental. By W. H. NORTHCOTT. With 338 Illustrations. 8vo., 18s.

SHELLEY.—WORKSHOP APPLIANCES, including Descriptions of some of the Gauging and Measuring Instruments, Hand-cutting Tools, Lathes, Drilling, Planeing, and other Machine Tools used by Engineers. By C. P. B. SHELLEY, M.I.C.E. With an additional Chapter on Milling by R. R. LISTER. With 323 Woodcuts. Fcp. 8vo., 5s.

MINERALOGY, METALLURGY, ETC.

BAUERMAN.—Works by HILARY BAUERMAN, F.G.S.

SYSTEMATIC MINERALOGY. With 373 Woodcuts and Diagrams. Fcp. 8vo., 6s.

DESCRIPTIVE MINERALOGY. With 236 Woodcuts and Diagrams. Fcp. 8vo., 6s.

GORE.—THE ART OF ELECTRO-METALLURGY, including all known Processes of Electro-Deposition. By G. GORE, LL.D., F.R.S. With 56 Woodcuts. Fcp. 8vo., 6s.

HUNTINGTON AND M'MILLAN.—METALS: their Properties and Treatment. By A. K. HUNTINGTON, Professor of Metallurgy in King's College, London, and W. G. M'MILLAN, Lecturer on Metallurgy in Mason's College, Birmingham. With 122 Illustrations. Fcp. 8vo., 7s. 6d.

RHEAD.—METALLURGY. An Elementary Text-Book. By E. C. RHEAD, Lecturer on Metallurgy at the Municipal Technical School, Manchester. With 94 Illustrations. Fcp. 8vo., 3s. 6d.

RUTLEY.—THE STUDY OF ROCKS: an Elementary Text-book of Petrology. By F. RUTLEY, F.G.S. With 6 Plates and 88 Woodcuts. Fcp. 8vo., 4s. 6d.

ASTRONOMY, NAVIGATION, ETC.

ABBOTT.—ELEMENTARY THEORY OF THE TIDES: the Fundamental Theorems Demonstrated without Mathematics and the Influence on the Length of the Day Discussed. By T. K. ABBOTT, B.D., Fellow and Tutor, Trinity College, Dublin. Crown 8vo., 2s.

BALL.—Works by Sir ROBERT S. BALL, LL.D., F.R.S.

ELEMENTS OF ASTRONOMY. With 130 Figures and Diagrams. Fcp. 8vo., 6s. 6d.

A CLASS-BOOK OF ASTRONOMY. With 41 Diagrams. Fcp. 8vo., 1s. 6d.

ASTRONOMY, NAVIGATION, ETC.—Continued.

- DE CAMPIGNEULLES.**—OBSERVATIONS TAKEN AT DUMRAON, BEHAR, INDIA, during the Eclipse of the 22nd January, 1898, by a Party of Jesuit Fathers of the Western Bengal Mission. By the Rev. V. DE CAMPIGNEULLES, S.J. With 14 Plates. 4to., 10s. 6d. net.
- GILL.**—TEXT-BOOK ON NAVIGATION AND NAUTICAL ASTRONOMY. By J. GILL, F.R.A.S., late Head Master of the Liverpool Corporation Nautical College. 8vo., 10s. 6d.
- HERSCHEL.**—OUTLINES OF ASTRONOMY. By Sir JOHN F. W. HERSCHEL, Bart., K.H., etc. With 9 Plates and numerous Diagrams. 8vo., 12s.
- JORDAN.**—ESSAYS IN ILLUSTRATION OF THE ACTION OF ASTRAL GRAVITATION IN NATURAL PHENOMENA. By WILLIAM LEIGHTON JORDAN. With Diagrams. 8vo., 9s.
- LAUGHTON.**—AN INTRODUCTION TO THE PRACTICAL AND THEORETICAL STUDY OF NAUTICAL SURVEYING. By JOHN KNOX LAUGHTON, M.A., F.R.A.S. With 35 Diagrams. Crown 8vo., 6s.
- LOWELL.**—MARS. By PERCIVAL LOWELL, Fellow American Academy, Member Royal Asiatic Society, Great Britain and Ireland, etc. With 24 Plates. 8vo., 12s. 6d.
- MARTIN.**—NAVIGATION AND NAUTICAL ASTRONOMY. Compiled by Staff Commander W. R. MARTIN, R.N. Royal 8vo., 18s.
- MERRIFIELD.**—A TREATISE ON NAVIGATION. For the Use of Students. By J. MERRIFIELD, LL.D., F.R.A.S., F.M.S. With Charts and Diagrams. Crown 8vo., 5s.
- PARKER.**—ELEMENTS OF ASTRONOMY. With Numerous Examples and Examination Papers. By GEORGE W. PARKER, M.A., of Trinity College, Dublin. With 84 Diagrams. 8vo., 5s. 6d. net.
- WEBB.**—CELESTIAL OBJECTS FOR COMMON TELESCOPES. By the Rev. T. W. WEBB, M.A., F.R.A.S. Fifth Edition, Revised and greatly Enlarged by the Rev. T. E. ESPIN, M.A., F.R.A.S. (Two Volumes.) Vol. I., with Portrait and a Reminiscence of the Author, 2 Plates, and numerous Illustrations. Crown 8vo., 6s. Vol. II., with numerous Illustrations. Crown 8vo., 6s. 6d.

WORKS BY RICHARD A. PROCTOR.

- THE MOON:** Her Motions, Aspect, Scenery, and Physical Condition. With many Plates and Charts, Wood Engravings, and 2 Lunar Photographs. Crown 8vo., 3s. 6d.
- OTHER WORLDS THAN OURS:** the Plurality of Worlds Studied Under the Light of Recent Scientific Researches. With 14 Illustrations; Map, Charts, etc. Crown 8vo., 3s. 6d.
- OUR PLACE AMONG INFINITIES:** a Series of Essays contrasting our Little Abode in Space and Time with the Infinities around us. Crown 8vo., 3s. 6d.

WORKS BY RICHARD A. PROCTOR—Continued.

- MYTHS AND MARVELS OF ASTRONOMY. Crown 8vo.,
3s. 6d.
- LIGHT SCIENCE FOR LEISURE HOURS: Familiar Essays
on Scientific Subjects, Natural Phenomena, etc. Vol. I. Crown 8vo., 3s. 6d.
- THE ORBS AROUND US; Essays on the Moon and Planets,
Meteors and Comets, the Sun and Coloured Pairs of Suns. Crown 8vo., 3s. 6d.
- THE EXPANSE OF HEAVEN: Essays on the Wonders of the
Firmament. Crown 8vo., 3s. 6d.
- OTHER SUNS THAN OURS: a Series of Essays on Suns—Old,
Young, and Dead. With other Science Gleanings. Two Essays on Whist,
and Correspondence with Sir John Herschel. With 9 Star-Maps and Diagrams.
Crown 8vo., 3s. 6d.
- HALF-HOURS WITH THE TELESCOPE: a Popular Guide
to the Use of the Telescope as a means of Amusement and Instruction. With
7 Plates. Fcp. 8vo., 2s. 6d.
- NEW STAR ATLAS FOR THE LIBRARY, the School, and
the Observatory, in Twelve Circular Maps (with Two Index-Plates). With an
Introduction on the Study of the Stars. Illustrated by 9 Diagrams. Cr. 8vo., 5s.
- THE SOUTHERN SKIES: a Plain and Easy Guide to the
Constellations of the Southern Hemisphere. Showing in 12 Maps the position
of the principal Star-Groups night after night throughout the year. With an
Introduction and a separate Explanation of each Map. True for every Year.
4to., 5s.
- HALF-HOURS WITH THE STARS: a Plain and Easy Guide
to the Knowledge of the Constellations. Showing in 12 Maps the position of
the principal Star-Groups night after night throughout the year. With Intro-
duction and a separate Explanation of each Map. True for every Year.
4to., 3s. 6d.
- LARGER STAR ATLAS FOR OBSERVERS AND STUDENTS.
In Twelve Circular Maps, showing 6000 Stars, 1500 Double Stars, Nebulæ, etc.
With 2 Index-Plates. Folio, 15s.
- THE STARS IN THEIR SEASONS: an Easy Guide to a
Knowledge of the Star-Groups. In 12 Large Maps. Imperial 8vo., 5s.
- ROUGH WAYS MADE SMOOTH. Familiar Essays on
Scientific Subjects. Crown 8vo., 3s. 6d.
- PLEASANT WAYS IN SCIENCE. Crown 8vo., 3s. 6d.
- NATURE STUDIES. By R. A. PROCTOR, GRANT ALLEN, A.
WILSON, T. FOSTER, and E. CLODD. Crown 8vo., 3s. 6d.
- LEISURE READINGS. By R. A. PROCTOR, E. CLODD, A.
WILSON, T. FOSTER, and A. C. RANYARD. Crown 8vo., 3s. 6d.

PHYSIOGRAPHY AND GEOLOGY.

BIRD.—Works by CHARLES BIRD, B.A.

ELEMENTARY GEOLOGY. With Geological Map of the
British Isles, and 247 Illustrations. Crown 8vo., 2s. 6d.

ADVANCED GEOLOGY. A Manual for Students in Advanced
Classes and for General Readers. With over 300 Illustrations, a Geological
Map of the British Isles (coloured), and a set of Questions for Examination.
Crown 8vo., 7s. 6d.

PHYSIOGRAPHY AND GEOLOGY—Continued.

GREEN.—**PHYSICAL GEOLOGY FOR STUDENTS AND GENERAL READERS.** By A. H. GREEN, M.A., F.G.S. With 236 Illustrations. 8vo., 21s.

MORGAN.—Works by ALEX. MORGAN, M.A., D.Sc., F.R.S.E.

ELEMENTARY PHYSIOGRAPHY. Treated Experimentally. With 4 Maps and 243 Diagrams. Crown 8vo., 2s. 6d.

ADVANCED PHYSIOGRAPHY. With 215 Illustrations. Crown 8vo., 4s. 6d.

THORNTON.—Works by J. THORNTON, M.A.

ELEMENTARY PRACTICAL PHYSIOGRAPHY.

Part I. With 215 Illustrations. Crown 8vo., 2s. 6d.

Part II. With 98 Illustrations. Crown 8vo., 2s. 6d.

ELEMENTARY PHYSIOGRAPHY: an Introduction to the Study of Nature. With 13 Maps and 295 Illustrations. With Appendix on Astronomical Instruments and Measurements. Crown 8vo., 2s. 6d.

ADVANCED PHYSIOGRAPHY. With 11 Maps and 255 Illustrations. Crown 8vo., 4s. 6d.

NATURAL HISTORY AND GENERAL SCIENCE.

BEDDARD.—**THE STRUCTURE AND CLASSIFICATION OF BIRDS.** By FRANK E. BEDDARD, M.A., F.R.S., Prosector and Vice-Secretary of the Zoological Society of London. With 252 Illus. 8vo., 21s. net.

FURNEAUX.—Works by WILLIAM FURNEAUX, F.R.G.S.

THE OUTDOOR WORLD; or, The Young Collector's Handbook. With 18 Plates, 16 of which are coloured, and 549 Illustrations in the Text. Crown 8vo., 6s. net.

LIFE IN PONDS AND STREAMS. With 8 Coloured Plates and 331 Illustrations in the Text. Crown 8vo., 6s. net.

BUTTERFLIES AND MOTHS (British). With 12 Coloured Plates and 241 Illustrations in the Text. Crown 8vo., 6s. net.

HUDSON.—**BRITISH BIRDS.** By W. H. HUDSON, C.M.Z.S. With 8 Coloured Plates from Original Drawings by A. THORBURN, and 8 Plates and 100 Figures by C. E. LODGE, and 3 Illustrations from Photographs. Crown 8vo., 6s. net.

NANSEN.—**THE NORWEGIAN NORTH POLAR EXPEDITION, 1893-1896: Scientific Results.** Edited by FRIDTJOF NANSEN. Volume I. With 44 Plates and numerous Illustrations in the Text. Demy 4to., 40s. net.

CONTENTS: The *Fram*—The Jurassic Fauna of Cape Flora. With a Geological Sketch of Cape Flora and its Neighbourhood—Fossil Plants from Franz Josef Land—An Account of the Birds—Crustacea.

Volume II. With 2 Charts and 17 Plates. Demy 4to., 30s. net.

CONTENTS: Astronomical Observations—Terrestrial Magnetism—Results of the Pendulum—Observations and some Remarks on the Constitution of the Earth's Crust.

ORMEROD.—**BRITISH SOCIAL WASPS: An Introduction to their Anatomy and Physiology, Architecture and General Natural History.** With 14 Plates illustrating the Different Species and their Nests. By EDWARD LATHAN ORMEROD, M.D. Crown 8vo., 10s. 6d.

STANLEY.—**A FAMILIAR HISTORY OF BIRDS.** By E. STANLEY, D.D., formerly Bishop of Norwich. With 160 Illustrations. Crown 8vo., 3s. 6d.

MANUFACTURES, TECHNOLOGY, ETC.

BELL.—JACQUARD WEAVING AND DESIGNING. By F. T. BELL. With 199 Diagrams. 8vo., 12s. net.

CALDER.—THE PREVENTION OF FACTORY ACCIDENTS: being an Account of Manufacturing Industry and Accident, and a Practical Guide to the Law on the Safe-guarding, Safe-working and Safe-construction of Factory Machinery, Plant and Premises. By JOHN CALDER. With 20 Tables and 124 Illustrations. Crown 8vo., 7s. 6d. net.

CROSS AND BEVAN.—Works by C. F. CROSS and E. J. BEVAN. **CELLULOSE:** an Outline of the Chemistry of the Structural Elements of Plants. With reference to their Natural History and Industrial Uses. (C. F. CROSS, E. J. BEVAN and C. BEADLE.) With 14 Plates. Crown 8vo., 12s. net.

RESEARCHES ON CELLULOSE, 1895-1900. Crown 8vo., 6s. net.

LUPTON.—MINING. An Elementary Treatise on the Getting of Minerals. By ARNOLD LUPTON, M.I.C.E., F.G.S., etc. With 596 Diagrams and Illustrations. Crown 8vo., 9s. net.

MORRIS AND WILKINSON.—THE ELEMENTS OF COTTON SPINNING. By JOHN MORRIS and F. WILKINSON. With a Preface by Sir B. A. DOBSON, C.E., M.I.M.E. With 169 Diagrams and Illustrations. Crown 8vo., 7s. 6d. net.

TAYLOR.—COTTON WEAVING AND DESIGNING. By JOHN T. TAYLOR. With 373 Diagrams. Crown 8vo., 7s. 6d. net.

WATTS.—AN INTRODUCTORY MANUAL FOR SUGAR GROWERS. By FRANCIS WATTS, F.C.S., F.I.C. With 20 Illustrations. Crown 8vo., 6s.

HEALTH AND HYGIENE.

ASHBY.—HEALTH IN THE NURSERY. By HENRY ASHBY, M.D., F.R.C.P. With 25 Illustrations. Crown 8vo., 3s. net.

BUCKTON.—HEALTH IN THE HOUSE. By Mrs. C. M. BUCKTON. With 41 Woodcuts and Diagrams. Crown 8vo., 2s.

CORFIELD.—THE LAWS OF HEALTH. By W. H. CORFIELD, M.A., M.D. Fcp. 8vo., 1s. 6d.

NOTTER AND FIRTH.—Works by J. L. NOTTER, M.A., M.D., and R. H. FIRTH, F.R.C.S.

HYGIENE. With 95 Illustrations. Crown 8vo., 3s. 6d.

PRACTICAL DOMESTIC HYGIENE. With 83 Illustrations. Crown 8vo., 2s. 6d.

POORE.—Works by GEORGE VIVIAN POORE, M.D.

ESSAYS ON RURAL HYGIENE. Crown 8vo., 6s. 6d.

THE DWELLING-HOUSE. With 36 Illustrations. Crown 8vo., 3s. 6d.

WILSON.—A MANUAL OF HEALTH-SCIENCE: adapted for use in Schools and Colleges. By ANDREW WILSON, F.R.S.E., F.L.S., etc. With 74 Illustrations. Crown 8vo., 2s. 6d.

MEDICINE AND SURGERY.

- ASHBY AND WRIGHT.**—THE DISEASES OF CHILDREN, MEDICAL AND SURGICAL. By HENRY ASHBY, M.D., Lond., F.R.C.P., Physician to the General Hospital for Sick Children, Manchester; and G. A. WRIGHT, B.A., M.B. Oxon., F.R.C.S., Eng., Assistant-Surgeon to the Manchester Royal Infirmary, and Surgeon to the Children's Hospital. Enlarged and Improved Edition. With 192 Illustrations. 8vo., 25s.
- BENNETT.**—Works by WILLIAM H. BENNETT, F.R.C.S., Surgeon to St. George's Hospital; Member of the Board of Examiners, Royal College of Surgeons of England.
- CLINICAL LECTURES ON VARICOSE VEINS OF THE LOWER EXTREMITIES. With 3 Plates. 8vo., 6s.
- ON VARICOCELE; A PRACTICAL TREATISE. With 4 Tables and a Diagram. 8vo., 5s.
- CLINICAL LECTURES ON ABDOMINAL HERNIA: chiefly in relation to Treatment, including the Radical Cure. With 12 Diagrams in the Text. 8vo., 8s. 6d.
- ON VARIX, ITS CAUSES AND TREATMENT, WITH ESPECIAL REFERENCE TO THROMBOSIS: an Address delivered at the Inaugural Meeting of the Nottingham Medico-Chirurgical Society, Session 1898-99. 8vo., 3s. 6d.
- THE PRESENT POSITION OF THE TREATMENT OF SIMPLE FRACTURES OF THE LIMBS. 8vo., 2s. 6d.
- ON THE USE OF MASSAGE AND EARLY PASSIVE MOVEMENTS IN RECENT FRACTURES AND OTHER COMMON SURGICAL INJURIES, AND THE TREATMENT OF INTERNAL DERANGEMENTS OF THE KNEE-JOINT. With 12 Illustrations. 8vo., 4s. 6d.
- BENTLEY.**—A TEXT-BOOK OF ORGANIC MATERIA MEDICA. Comprising a Description of the Vegetable and Animal Drugs of the British Pharmacopœia, with some others in common use. Arranged Systematically, and Especially Designed for Students. By ROBERT BENTLEY, M.R.C.S. Eng., F.L.S. With 62 Illustrations on Wood. Crown 8vo., 7s. 6d.
- BRODIE.**—THE ESSENTIALS OF EXPERIMENTAL PHYSIOLOGY. For the Use of Students. By T. G. BRODIE, M.D., Lecturer on Physiology, St. Thomas's Hospital Medical School. With 2 Plates and 177 Illustrations in the Text. Crown 8vo., 6s. 6d.
- CABOT.**—Works by RICHARD C. CABOT, M.D., Physician to Out-patients, Massachusetts General Hospital.
- A GUIDE TO THE CLINICAL EXAMINATION OF THE BLOOD FOR DIAGNOSTIC PURPOSES. With 3 Coloured Plates and 28 Illustrations in the Text. 8vo., 16s.
- THE SERUM DIAGNOSIS OF DISEASE. With 31 Temperature Charts and 9 Illustrations. Royal 8vo., 7s. 6d.
- CELLI.**—MALARIA, ACCORDING TO THE NEW RESEARCHES. By Prof. ANGELO CELLI, Director of the Institute of Hygiene, University of Rome. Translated from the Second Italian Edition by JOHN JOSEPH EYRE, M.R.C.P., L.R.C.S. Ireland, D.P.H. Cambridge. With an Introduction by Dr. PATRICK MANSON, Medical Adviser to the Colonial Office. 8vo., 10s. 6d.

MEDICINE AND SURGERY—Continued.

CHEYNE AND BURGHARD.—A MANUAL OF SURGICAL

TREATMENT. By W. WATSON CHEYNE, C.B. M.B., F.R.C.S., F.R.S., Professor of Surgery in King's College, London, Surgeon to King's College Hospital, etc.; and F. F. BURGHARD, M.D. and M.S., F.R.C.S., Teacher of Practical Surgery in King's College, London, Surgeon to King's College Hospital (Lond.), etc.

Part I. The Treatment of General Surgical Diseases, including Inflammation, Suppuration, Ulceration, Gangrene, Wounds and their Complications, Infective Diseases and Tumours; the Administration of Anæsthetics. With 66 Illustrations. Royal 8vo., 10s. 6d. [Ready.]

Part II. The Treatment of the Surgical Affections of the Tissues, including the Skin and Subcutaneous Tissues, the Nails, the Lymphatic Vessels and Glands, the Fasciæ, Bursæ, Muscles, Tendons and Tendon-sheaths, Nerves, Arteries and Veins. Deformities. With 141 Illustrations. Royal 8vo., 14s. [Ready.]

Part III. The Treatment of the Surgical Affections of the Bones. Amputations. With 100 Illustrations. Royal 8vo., 12s.

Part IV. The Treatment of the Surgical Affections of the Joints (including Excisions) and the Spine. With 138 Illustrations. Royal 8vo., 14s.

Part V. The Treatment of the Surgical Affections of the Head, Face, Jaws, Lips, Larynx and Trachea; and the Intrinsic Diseases of the Nose, Ear and Larynx, by H. LAMBERT LACK, M.D. (Lond.), F.R.C.S., Surgeon to the Hospital for Diseases of the Throat, Golden Square, and to the Throat and Ear Department, The Children's Hospital, Paddington Green. With 145 Illustrations. Royal 8vo., 18s.

CLARKE.—Works by J. JACKSON CLARKE, M.B. Lond., F.R.C.S., Assistant Surgeon at the North-west London and City Orthopædic Hospitals, etc.

SURGICAL PATHOLOGY AND PRINCIPLES. With 194 Illustrations. Crown 8vo., 10s. 6d.

POST-MORTEM EXAMINATIONS IN MEDICO-LEGAL AND ORDINARY CASES. With Special Chapters on the Legal Aspects of Post-mortems, and on Certificates of Death. Fcp. 8vo., 2s. 6d.

COATS.—A MANUAL OF PATHOLOGY. By JOSEPH COATS, M.D., late Professor of Pathology in the University of Glasgow. Fourth Edition. Revised throughout and Edited by LEWIS R. SUTHERLAND, M.D., Professor of Pathology, University of St. Andrews. With 490 Illustrations. 8vo., 31s. 6d.

COOKE.—Works by THOMAS COOKE, F.R.C.S. Eng., B.A., B.Sc., M.D., Paris.

TABLETS OF ANATOMY. Being a Synopsis of Demonstrations given in the Westminster Hospital Medical School. Eleventh Edition in Three Parts, thoroughly brought up to date, and with over 700 Illustrations from all the best Sources, British and Foreign. Post 4to.

Part I. The Bones. 7s. 6d. net.

Part II. Limbs, Abdomen, Pelvis. 10s. 6d. net.

Part III. Head and Neck, Thorax, Brain. 10s. 6d. net.

APHORISMS IN APPLIED ANATOMY AND OPERATIVE SURGERY. Including 100 Typical *vivâ voce* Questions on Surface Marking, etc. Crown 8vo., 3s. 6d.

DISSECTION GUIDES. Aiming at Extending and Facilitating such Practical work in Anatomy as will be specially useful in connection with an ordinary Hospital Curriculum. 8vo., 10s. 6d.

MEDICINE AND SURGERY—Continued.

- DAKIN.**—A HANDBOOK OF MIDWIFERY. By WILLIAM RADFORD DAKIN, M.D., F.R.C.P., Obstetric Physician and Lecturer on Midwifery at St. George's Hospital, etc. With 394 Illustrations. Large crown 8vo., 18s.
- DICKINSON.**—Works by W. HOWSHIP DICKINSON, M.D. Cantab., F.R.C.P.
- ON RENAL AND URINARY AFFECTIONS. With 12 Plates and 122 Woodcuts. Three Parts. 8vo., £3 4s. 6d.
- THE TONGUE AS AN INDICATION OF DISEASE; being the Lumleian Lectures delivered March, 1888. 8vo., 7s. 6d.
- OCCASIONAL PAPERS ON MEDICAL SUBJECTS, 1855-1896. 8vo., 12s.
- MEDICINE OLD AND NEW. An Address Delivered on the Occasion of the Opening of the Winter Session, 1899-1900, at St. George's Hospital Medical School, on 2nd October, 1899. Crown 8vo., 2s. 6d.
- DUCKWORTH.**—Works by SIR DYCE DUCKWORTH, M.D., LL.D., Fellow and Treasurer of the Royal College of Physicians, etc.
- THE SEQUELS OF DISEASE: being the Lumleian Lectures, 1896. 8vo., 10s. 6d.
- THE INFLUENCE OF CHARACTER AND RIGHT JUDGMENT IN MEDICINE: the Harveian Oration, 1898. Post 4to. 2s. 6d.
- ERICHSEN.**—THE SCIENCE AND ART OF SURGERY; a Treatise on Surgical Injuries, Diseases, and Operations. By Sir JOHN ERICHSEN, Bart., F.R.S., LL.D. Edin., Hon. M.Ch. and F.R.C.S. Ireland. Illustrated by nearly 1000 Engravings on Wood. 2 vols. Royal 8vo., 48s.
- FOWLER AND GODLEE.**—THE DISEASES OF THE LUNGS. By JAMES KINGSTON FOWLER, M.A., M.D., F.R.C.P., Physician to the Middlesex Hospital and to the Hospital for Consumption and Diseases of the Chest, Brompton, etc.; and RICKMAN JOHN GODLEE, Honorary Surgeon in Ordinary to His Majesty, M.S., F.R.C.S., Fellow and Professor of Clinical Surgery, University College, London, etc. With 160 Illustrations. 8vo., 25s.
- GARROD.**—Works by SIR ALFRED BARING GARROD, M.D., F.R.S., etc.
- A TREATISE ON GOUT AND RHEUMATIC GOUT (RHEUMATOID ARTHRITIS). With 6 Plates, comprising 21 Figures (14 Coloured), and 27 Illustrations engraved on Wood. 8vo., 21s.
- THE ESSENTIALS OF MATERIA MEDICA AND THERAPEUTICS. Crown 8vo., 12s. 6d.
- GOODSALL AND MILES.**—DISEASES OF THE ANUS AND RECTUM. By D. H. GOODSALL, F.R.C.S., Senior Surgeon, Metropolitan Hospital; Senior Surgeon, St. Mark's Hospital; and W. ERNEST MILES, F.R.C.S., Assistant Surgeon to the Cancer Hospital, Surgeon (out-patients), to the Gordon Hospital, etc. (In Two Parts.) Part I. With 91 Illustrations. 8vo., 7s. 6d. net.

MEDICINE AND SURGERY—Continued.

- GRAY.**—ANATOMY, DESCRIPTIVE AND SURGICAL. By HENRY GRAY, F.R.S., late Lecturer on Anatomy at St. George's Hospital. The Fourteenth Edition, re-edited by T. PICKERING PICK, Surgeon to St. George's Hospital, Inspector of Anatomy in England and Wales, late Member of the Court of Examiners, Royal College of Surgeons of England. With 705 large Woodcut Illustrations, a large proportion of which are Coloured, the Arteries being coloured red, the Veins blue, and the Nerves yellow. The attachments of the muscles to the bones, in the section on Osteology, are also shown in coloured outline. Royal 8vo., 36s.
- HALLIBURTON.**—Works by W. D. HALLIBURTON, M.D., F.R.S., F.R.C.P., Professor of Physiology in King's College, London.
- A TEXT-BOOK OF CHEMICAL PHYSIOLOGY AND PATHOLOGY. With 104 Illustrations. 8vo., 28s.
- ESSENTIALS OF CHEMICAL PHYSIOLOGY. With 77 Illustrations. 8vo., 5s.
- LANG.**—THE METHODICAL EXAMINATION OF THE EYE. Being Part I. of a Guide to the Practice of Ophthalmology for Students and Practitioners. By WILLIAM LANG, F.R.C.S. Eng., Surgeon to the Royal London Ophthalmic Hospital, Moorfields, etc. With 15 Illustrations. Crown 8vo., 3s. 6d.
- LIVEING.**—HANDBOOK ON DISEASES OF THE SKIN. With especial reference to Diagnosis and Treatment. By ROBERT LIVEING, M.A. and M.D., Cantab., F.R.C.P. Lond., etc., Physician to the Department for Diseases of the Skin at the Middlesex Hospital, etc. Fcp. 8vo., 5s.
- LUFF.**—TEXT-BOOK OF FORENSIC MEDICINE AND TOXICOLOGY. By ARTHUR P. LUFF, M.D., B.Sc. (Lond.), Physician in Charge of Out-Patients and Lecturer on Medical Jurisprudence and Toxicology in St. Mary's Hospital. With 13 full-page Plates (1 in colours) and 33 Illustrations in the Text. 2 vols. Crown 8vo., 24s.
- NEWMAN.**—ON THE DISEASES OF THE KIDNEY AMENABLE TO SURGICAL TREATMENT. Lectures to Practitioners. By DAVID NEWMAN, M.D., Surgeon to the Western Infirmary Out-Door Department; Pathologist and Lecturer on Pathology at the Glasgow Royal Infirmary; Examiner in Pathology in the University of Glasgow; Vice-President, Glasgow Pathological and Clinical Society. 8vo., 8s.
- PICK.**—SURGERY: a Treatise for Students and Practitioners. By T. PICKERING PICK, Consulting Surgeon to St. George's Hospital; Senior Surgeon to the Victoria Hospital for Children; H.M. Inspector of Anatomy in England and Wales. With 441 Illustrations. Medium 8vo., 25s.
- POOLE.**—COOKERY FOR THE DIABETIC. By W. H. and Mrs. POOLE. With Preface by Dr. PAVY. Fcap. 8vo., 2s. 6d.
- QUAIN.**—A DICTIONARY OF MEDICINE; Including General Pathology, General Therapeutics, Hygiene, and the Diseases of Women and Children. By Various Writers. Edited by Sir RICHARD QUAIN, Bart., M.D. Lond., LL.D. Edin. (Hon.) F.R.S. Assisted by FREDERICK THOMAS ROBERTS, M.D. Lond., B.Sc., Fellow of the Royal College of Physicians, Fellow of University College, etc.; and J. MITCHELL BRUCE, M.A. Abdn., M.D. Lond., Fellow of the Royal College of Physicians of London, etc. 2 Vols. Medium 8vo., 40s. net.

MEDICINE AND SURGERY—Continued.

QUAIN.—**QUAIN'S (JONES) ELEMENTS OF ANATOMY.**

The Tenth Edition. Edited by EDWARD ALBERT SCHÄFER, F.R.S., Professor of Physiology in the University of Edinburgh; and GEORGE DANCER THANE, Professor of Anatomy in University College, London.

** The several parts of this work form COMPLETE TEXT-BOOKS OF THEIR RESPECTIVE SUBJECTS.

VOL. I., PART I. EMBRYOLOGY. By E. A. SCHÄFER, F.R.S. With 200 Illustrations. Royal 8vo., 9s.

VOL. I., PART II. GENERAL ANATOMY OR HISTOLOGY. By E. A. SCHÄFER, F.R.S. With 291 Illustrations. Royal 8vo., 12s. 6d.

VOL. II., PART I. OSTEOLOGY—ARTHROLOGY. By G. D. THANE. With 224 Illus. Royal 8vo., 11s.

VOL. II., PART II. MYOLOGY—ANGEIOLOGY. By G. D. THANE. With 199 Illustrations. Royal 8vo., 16s.

VOL. III., PART I. THE SPINAL CORD AND BRAIN. By E. A. SCHÄFER, F.R.S. With 139 Illustrations. Royal 8vo., 12s. 6d.

VOL. III., PART II. THE NERVES. By G. D. THANE. With 102 Illustrations. Royal 8vo., 9s.

VOL. III., PART III. THE ORGANS OF THE SENSES. By E. A. SCHÄFER, F.R.S. With 178 Illustrations. Royal 8vo., 9s.

VOL. III., PART IV. SPLANCHNOLOGY. By E. A. SCHÄFER, F.R.S., and JOHNSON SYMINGTON, M.D. With 337 Illustrations. Royal 8vo., 16s.

APPENDIX. SUPERFICIAL AND SURGICAL ANATOMY. By Professor G. D. THANE and Professor R. J. GODLEE, M.S. With 29 Illustrations. Royal 8vo., 6s. 6d.

SCHÄFER.—**THE ESSENTIALS OF HISTOLOGY.** Descriptive and Practical. For the Use of Students. By E. A. SCHÄFER, F.R.S., Professor of Physiology in the University of Edinburgh; Editor of the Historical Portion of Quain's 'Anatomy'. Illustrated by nearly 400 Figures. Fifth Edition, Revised and Enlarged. 8vo., 8s.

SCHENK.—**MANUAL OF BACTERIOLOGY.** For Practitioners and Students. With especial reference to Practical Methods. By Dr. S. L. SCHENK, Professor (Extraordinary) in the University of Vienna. Translated from the German, with an Appendix, by W. R. DAWSON, B.A., M.D., Univ. Dub.; late University Travelling Prizeman in Medicine. With 100 Illustrations, some of which are coloured. 8vo., 10s. net.

SMALE AND COLYER. **DISEASES AND INJURIES OF THE TEETH,** including Pathology and Treatment: a Manual of Practical Dentistry for Students and Practitioners. By MORTON SMALE, M.R.C.S., L.S.A., L.D.S., Dental Surgeon to St. Mary's Hospital, Dean of the School, Dental Hospital of London, etc.; and J. F. COLYER, L.R.C.P., M.R.C.S., L.D.S., Assistant Dental Surgeon to Charing Cross Hospital, and Assistant Dental Surgeon to the Dental Hospital of London. With 334 Illustrations. Large crown 8vo., 15s.

SMITH (H. F.). **THE HANDBOOK FOR MIDWIVES.** By HENRY FLY SMITH, B.A., M.B. Oxon., M.R.C.S. 41 Woodcuts. Cr. 8vo., 5s.

STEVENSON.—**WOUNDS IN WAR: the Mechanism of their Production and their Treatment.** By Surgeon-Colonel W. F. STEVENSON (Army Medical Staff), A.B., M.B., M.Ch. Dublin University, Professor of Military Surgery, Army Medical School, Netley. With 86 Illustrations. 8vo., 18s.

TAPPEINER. — **INTRODUCTION TO CHEMICAL METHODS OF CLINICAL DIAGNOSIS.** By Dr. H. TAPPEINER, Professor of Pharmacology and Principal of the Pharmacological Institute of the University of Munich. Translated by EDMOND J. MCWEENEY, M.A., M.D. (Royal Univ. of Ireland), L.R.C.P.I., etc. Crown 8vo., 3s. 6d.

MEDICINE AND SURGERY—Continued.

TIRARD.—DIPHTHERIA AND ANTITOXIN. By NESTOR TIRARD, M.D. Lond., Fellow of the Royal College of Physicians; Fellow of King's College, London; Professor of Materia Medica and Therapeutics at King's College; Physician to King's College Hospital; and Senior Physician to the Evelina Hospital for Sick Children. 8vo., 7s. 6d.

WALLER.—Works by AUGUSTUS D. WALLER, M.D., Lecturer on Physiology at St. Mary's Hospital Medical School, London; late External Examiner at the Victorian University. 2s.

AN INTRODUCTION TO HUMAN PHYSIOLOGY. Third Edition, Revised. With 314 Illustrations. 8vo., 18s.

LECTURES ON PHYSIOLOGY. First Series. On Animal Electricity. 8vo., 5s. net.

EXERCISES IN PRACTICAL PHYSIOLOGY. Part I. Elementary Physiological Chemistry. By AUGUSTUS D. WALLER and W. LEGGE SYMES. 8vo., 1s. net. Part II. in the press. Part III. Physiology of the Nervous System; Electro-Physiology. 8vo., 2s. 6d. net.

WEICHSELBAUM.—THE ELEMENTS OF PATHOLOGICAL HISTOLOGY, With Special Reference to Practical Methods. By Dr. ANTON WEICHSELBAUM, Professor of Pathology in the University of Vienna. Translated by W. R. DAWSON, M.D. (Dub.), Demonstrator of Pathology in the Royal College of Surgeons, Ireland, late Medical Travelling Prizeman of Dublin University, etc. With 221 Figures, partly in Colours, a Chromo-lithographic Plate, and 7 Photographic Plates. Royal 8vo., 21s. net.

WILKS AND MOXON.—LECTURES ON PATHOLOGICAL ANATOMY. By Sir SAMUEL WILKS, Bart., M.D., F.R.S., Past President of the Royal College of Physicians, and the late WALTER MOXON, M.D., F.R.C.P., Physician to, and some time Lecturer on Pathology at, Guy's Hospital. Third Edition, thoroughly Revised. By Sir SAMUEL WILKS, Bart., M.D., LL.D., F.R.S. 8vo., 18s.

VETERINARY MEDICINE, ETC.

FITZWYGRAM.—HORSES AND STABLES. By Lieut.-General Sir F. FITZWYGRAM, Bart. With 56 pages of Illustrations. 8vo., 3s. net.

STEEL.—Works by JOHN HENRY STEEL, F.R.C.V.S., F.Z.S., A.V.D., late Professor of Veterinary Science and Principal of Bombay Veterinary College.

A TREATISE ON THE DISEASES OF THE DOG; being a Manual of Canine Pathology. Especially adapted for the use of Veterinary Practitioners and Students. With 88 Illustrations. 8vo., 10s 6d.

A TREATISE ON THE DISEASES OF THE OX; being a Manual of Bovine Pathology. Especially adapted for the use of Veterinary Practitioners and Students. With 2 Plates and 117 Woodcuts. 8vo. 15s.

A TREATISE ON THE DISEASES OF THE SHEEP; being a Manual of Ovine Pathology for the use of Veterinary Practitioners and Students. With Coloured Plate and 99 Woodcuts. 8vo., 12s.

VETERINARY MEDICINE, ETC.—Continued.

YOUATT.—Works by WILLIAM YOUATT.

THE HORSE. With 52 Wood Engravings. 8vo., 7s. 6d.

THE DOG. With 33 Wood Engravings. 8vo., 6s.

PHYSIOLOGY, BIOLOGY, BACTERIOLOGY, AND ZOOLOGY.

(And see *MEDICINE AND SURGERY*.)

ASHBY.—NOTES ON PHYSIOLOGY FOR THE USE OF STUDENTS PREPARING FOR EXAMINATION. By HENRY ASHBY, M.D. Lond., F.R.C.P., Physician to the General Hospital for Sick Children, Manchester; formerly Demonstrator of Physiology, Liverpool School of Medicine. With 148 Illustrations. 18mo., 5s.

BARNETT.—THE MAKING OF THE BODY: a Children's Book on Anatomy and Physiology. By Mrs. S. A. BARNETT. With 113 Illustrations. Crown 8vo., 1s. 9d.

BEDDARD.—Works by FRANK E. BEDDARD, M.A. Oxon.
ELEMENTARY PRACTICAL ZOOLOGY. With 93 Illustrations. Crown 8vo., 2s. 6d.

THE STRUCTURE AND CLASSIFICATION OF BIRDS.
With 252 Illustrations. 8vo., 21s. net.

BIDGOOD.—A COURSE OF PRACTICAL ELEMENTARY BIOLOGY. By JOHN BIDGOOD, B.Sc., F.L.S. With 226 Illustrations. Crown 8vo., 4s. 6d.

BRAY.—PHYSIOLOGY AND THE LAWS OF HEALTH, in Easy Lessons for Schools. By Mrs. CHARLES BRAY. Fcp. 8vo., 1s.

BRODIE.—THE ESSENTIALS OF EXPERIMENTAL PHYSIOLOGY. For the Use of Students. By T. G. BRODIE, M.D., Lecturer on Physiology, St. Thomas's Hospital Medical School. With 2 Plates and 177 Illustrations in the Text. Crown 8vo., 6s. 6d.

CURTIS.—THE ESSENTIALS OF PRACTICAL BACTERIOLOGY: An Elementary Laboratory Book for Students and Practitioners. By H. J. CURTIS, B.S. and M.D. (Lond.), F.R.C.S. With 133 Illustrations. 8vo., 9s.

FRANKLAND.—MICRO-ORGANISMS IN WATER. Together with an Account of the Bacteriological Methods involved in their Investigation. Specially designed for the use of those connected with the Sanitary Aspects of Water-Supply. By PERCY FRANKLAND, Ph.D., B.Sc. (Lond.), F.R.S., and Mrs. PERCY FRANKLAND. With 2 Plates and Numerous Diagrams. 8vo., 16s. net.

FURNEAUX.—HUMAN PHYSIOLOGY. By W. FURNEAUX, F.R.G.S. With 218 Illustrations. Crown 8vo., 2s. 6d.

HUDSON AND GOSSE.—THE ROTIFERA, or 'WHEEL-ANIMACULES'. By C. T. HUDSON, LL.D., and P. H. GOSSE, F.R.S. With 30 Coloured and 4 Uncoloured Plates. In 6 Parts. 4to., 10s. 6d. each. Supplement 12s. 6d. Complete in 2 vols., with Supplement, 4to., £4 4s.

PHYSIOLOGY, BIOLOGY, BACTERIOLOGY, AND ZOOLOGY—Cont.

MACALISTER.—Works by ALEXANDER MACALISTER, M.D.

AN INTRODUCTION TO THE SYSTEMATIC ZOOLOGY AND MORPHOLOGY OF VERTEBRATE ANIMALS. With 41 Diagrams 8vo., 10s. 6d.

ZOOLOGY OF THE INVERTEBRATE ANIMALS. With 59 Diagrams. Fcp. 8vo., 1s. 6d.

ZOOLOGY OF THE VERTEBRATE ANIMALS. With 77 Diagrams. Fcp. 8vo., 1s. 6d.

MOORE.—ELEMENTARY PHYSIOLOGY. By BENJAMIN MOORE, M.A., Lecturer on Physiology at the Charing Cross Hospital Medical School. With 125 Illustrations. Crown 8vo., 3s. 6d.

MORGAN.—ANIMAL BIOLOGY: an Elementary Text-Book. By C. LLOYD MORGAN, F.R.S., Principal of University College, Bristol. With 103 Illustrations. Crown 8vo., 8s. 6d.

SCHENK.—MANUAL OF BACTERIOLOGY, for Practitioners and Students, with Especial Reference to Practical Methods. By Dr. S. L. SCHENK. With 100 Illustrations, some Coloured. 8vo., 10s. net.

THORNTON.—HUMAN PHYSIOLOGY. By JOHN THORNTON, M.A. With 267 Illustrations, some Coloured. Crown 8vo., 6s.

BOTANY.

AITKEN.—ELEMENTARY TEXT-BOOK OF BOTANY. By EDITH AITKEN, late Scholar of Girton College. With 400 Diagrams. Crown 8vo., 4s. 6d.

BENNETT AND MURRAY.—HANDBOOK OF CRYPTO-GAMIC BOTANY. By ALFRED W. BENNETT, M.A., B.Sc., F.L.S., Lecturer on Botany at St. Thomas's Hospital; and GEORGE MURRAY, F.L.S., Keeper of Botany, British Museum. With 378 Illustrations. 8vo., 16s.

CROSS AND BEVAN.—CELLULOSE: an Outline of the Chemistry of the Structural Elements of Plants. With Reference to their Natural History and Industrial Uses. By CROSS and BEVAN (C. F. Cross, E. J. Bevan, and C. Beadle). With 14 Plates. Crown 8vo., 12s. net.

CURTIS.—A TEXT-BOOK OF GENERAL BOTANY. By CARLTON C. CURTIS, A.M., Ph.D., Tutor in Botany in Columbia University, U.S.A. With 87 Illustrations. 8vo., 12s. net.

EDMONDS.—Works by HENRY EDMONDS, B.Sc., London.
ELEMENTARY BOTANY. With 342 Illustrations. Cr. 8vo., 2s. 6d.
BOTANY FOR BEGINNERS. With 85 Illustrations. Fcp. 8vo., 1s. 6d.

FARMER.—A PRACTICAL INTRODUCTION TO THE STUDY OF BOTANY: Flowering Plants. By J. BRETLAN FARMER, F.R.S., M.A., Professor of Botany in the Royal College of Science, London. With 121 Illustrations. Crown 8vo., 2s. 6d.

BOTANY—Continued.

- KITCHENER.**—A YEAR'S BOTANY. Adapted to Home and School Use. By FRANCES A. KITCHENER. With 195 Illustrations. Cr. 8vo., 5s.
- LINDLEY AND MOORE.**—THE TREASURY OF BOTANY. Edited by J. LINDLEY, M.D., F.R.S., and T. MOORE, F.L.S. With 20 Steel Plates and numerous Woodcuts. Two parts. Fcp. 8vo., 12s.
- McNAB.**—CLASS-BOOK OF BOTANY. By W. R. McNAB. MORPHOLOGY AND PHYSIOLOGY. With 42 Diagrams. Fcp. 8vo., 1s. 6d. CLASSIFICATION OF PLANTS. With 118 Diagrams. Fcp. 8vo., 1s. 6d.
- SORAUER.**—A POPULAR TREATISE ON THE PHYSIOLOGY OF PLANTS. By Dr. PAUL SORAUER. Translated by F. E. WEISS, B.Sc., F.L.S. With 33 Illustrations. 8vo., 9s. net.
- THOMÉ AND BENNETT.**—STRUCTURAL AND PHYSIOLOGICAL BOTANY. By OTTO WILHELM THOMÉ and by ALFRED W. BENNETT, B.Sc., F.L.S. With Coloured Map and 600 Woodcuts. Fcp. 8vo., 6s.
- TUBEUF.**—DISEASES OF PLANTS INDUCED BY CRYPTOGAMIC PARASITES. Introduction to the Study of Pathogenic Fungi, Slime Fungi, Bacteria and Algæ. By Dr. KARL FREIHERR VON TUBEUF, Privatdocent in the University of Munich. English Edition by WILLIAM G. SMITH, B.Sc., Ph.D., Lecturer on Plant Physiology, University of Edinburgh. With 330 Illustrations. Royal 8vo., 18s. net.

AGRICULTURE AND GARDENING.

- ADDYMAN.**—AGRICULTURAL ANALYSIS. A Manual of Quantitative Analysis for Students of Agriculture. By FRANK T. ADDYMAN, B.Sc. (Lond.), F.I.C. With 49 Illustrations. Crown 8vo., 5s. net.
- COLEMAN AND ADDYMAN.**—PRACTICAL AGRICULTURAL CHEMISTRY. By J. BERNARD COLEMAN, A.R.C.Sc., F.I.C., and FRANK T. ADDYMAN, B.Sc. (Lond.), F.I.C. With 24 Illustrations. Crown 8vo., 1s 6d. net.
- HAGGARD.**—A FARMER'S YEAR: being his Commonplace Book for 1898. By H. RIDER HAGGARD. With 36 Illustrations by G. LEON LITTLE and three others. Crown 8vo., 7s. 6d. net.
- WATTS.**—A SCHOOL FLORA. For the use of Elementary Botanical Classes. By W. MARSHALL WATTS, D.Sc. Lond. Cr. 8vo., 2s. 6d.
- WEATHERS.**—A PRACTICAL GUIDE TO GARDEN PLANTS. Containing Descriptions of the Hardest and most Beautiful Annuals and Biennials, Hardy Herbaceous and Bulbous Perennials, Hardy Water and Bog Plants, Flowering and Ornamental Trees and Shrubs, Conifers, Hardy Ferns, Hardy Bamboos and other Ornamental Grasses; and also the best kinds of Fruit and Vegetables that may be grown in the Open Air in the British Islands, with Full and Practical Instructions as to Culture and Propagation. By JOHN WEATHERS, F.R.H.S., late Assistant Secretary to the Royal Horticultural Society, formerly of the Royal Gardens, Kew, etc. With 163 Diagrams. 8vo., 21s. net.
- WEBB.**—Works by HENRY J. WEBB, Ph.D., B.Sc. (Lond.).
- ELEMENTARY AGRICULTURE.** A Text-Book specially adapted to the requirements of the Science and Art Department, the Junior Examination of the Royal Agricultural Society, and other Elementary Examinations. With 34 Illustrations. Crown 8vo., 2s. 6d.
- AGRICULTURE.** A Manual for Advanced Science Students. With 100 Illustrations. Crown 8vo., 7s. 6d. net

WORKS BY JOHN TYNDALL, D.C.L., LL.D., F.R.S.

FRAGMENTS OF SCIENCE: a Series of Detached Essays, Addresses, and Reviews. 2 vols. Crown 8vo., 16s.

Vol. I.—The Constitution of Nature—Radiation—On Radiant Heat in Relation to the Colour and Chemical Constitution of Bodies—New Chemical Reactions produced by Light—On Dust and Disease—Voyage to Algeria to observe the Eclipse—Niagara—The Parallel Roads of Glen Roy—Alpine Sculpture—Recent Experiments on Fog-Signals—On the Study of Physics—On Crystalline and Slaty Cleavage—On Paramagnetic and Diamagnetic Forces—Physical Basis of Solar Chemistry—Elementary Magnetism—On Force—Contributions to Molecular Physics—Life and Letters of FARADAY—The Copley Medallist of 187c—The Copley Medallist of 1871—Death by Lightning—Science and the Spirits.

Vol. II.—Reflections on Prayer and Natural Law—Miracles and Special Providences—On Prayer as a Form of Physical Energy—Vitality—Matter and Force—Scientific Materialism—An Address to Students—Scientific Use of the Imagination—The Belfast Address—Apology for the Belfast Address—The Rev. JAMES MARTINEAU and the Belfast Address—Fermentation, and its Bearings on Surgery and Medicine—Spontaneous Generation—Science and Man—Professor VIRCHOW and Evolution—The Electric Light.

NEW FRAGMENTS. Crown 8vo., 10s. 6d.

CONTENTS.—The Sabbath—Goethe's 'Farbenlehre'—Atoms, Molecules, and Ether Waves—Count Rumford—Louis Pasteur, his Life and Labours—The Rainbow and its Congeners—Address delivered at the Birkbeck Institution on October 22, 1884—Thomas Young—Life in the Alps—About Common Water—Personal Recollections of Thomas Carlyle—On Unveiling the Statue of Thomas Carlyle—On the Origin, Propagation, and Prevention of Phthisis—Old Alpine Jottings—A Morning on Alp Lusgen.

LECTURES ON SOUND. With Frontispiece of Fog-Syren, and 203 other Woodcuts and Diagrams in the Text. Crown 8vo., 10s. 6d.

HEAT, A MODE OF MOTION. With 125 Woodcuts and Diagrams. Crown 8vo., 12s.

LECTURES ON LIGHT DELIVERED IN THE UNITED STATES IN 1872 AND 1873. With Portrait, Lithographic Plate, and 59 Diagrams. Crown 8vo., 5s.

ESSAYS ON THE FLOATING MATTER OF THE AIR IN RELATION TO PUTREFACTION AND INFECTION. With 24 Woodcuts. Crown 8vo., 7s. 6d.

RESEARCHES ON DIAMAGNETISM AND MAGNECRYSTALLIC ACTION; including the Question of Diamagnetic Polarity. Crown 8vo., 12s.

NOTES OF A COURSE OF NINE LECTURES ON LIGHT, delivered at the Royal Institution of Great Britain, 1869. Crown 8vo., 1s. 6d.

NOTES OF A COURSE OF SEVEN LECTURES ON ELECTRICAL PHENOMENA AND THEORIES, delivered at the Royal Institution of Great Britain, 1870. Crown 8vo., 1s. 6d.

LESSONS IN ELECTRICITY AT THE ROYAL INSTITUTION 1875-1876. With 58 Woodcuts and Diagrams. Crown 8vo., 2s. 6d.

THE GLACIERS OF THE ALPS: being a Narrative of Excursions and Ascents. An Account of the Origin and Phenomena of Glaciers, and an Exposition of the Physical Principles to which they are related. With 7 Illustrations. Crown 8vo., 6s. 6d. net.

HOURS OF EXERCISE IN THE ALPS. With 7 Illustrations. Crown 8vo., 6s. 6d. net.

FARADAY AS A DISCOVERER. Crown 8vo., 3s. 6d.

TEXT-BOOKS OF SCIENCE.

- PHOTOGRAPHY.** By Sir WILLIAM DE WIVELESLEIE ABNEY, K.C.B., F.R.S. With Illustrations. Fcp. 8vo.
- THE STRENGTH OF MATERIAL AND STRUCTURES.** By Sir J. ANDERSON, C.E. With 66 Illustrations. Fcp. 8vo., 3s. 6d.
- RAILWAY APPLIANCES.** By Sir JOHN WOLFE BARRY, K.C.B., F.R.S., M.I.C.E. With 218 Illustrations. Fcp. 8vo., 4s. 6d.
- INTRODUCTION TO THE STUDY OF INORGANIC CHEMISTRY.** By WILLIAM ALLEN MILLER, M.D., LL.D., F.R.S. With 72 Illustrations. 3s. 6d.
- QUANTITATIVE CHEMICAL ANALYSIS.** By T. E. THORPE, C.B., F.R.S., Ph.D. With 88 Illustrations. Fcp. 8vo., 4s. 6d.
- QUALITATIVE ANALYSIS AND LABORATORY PRACTICE.** By T. E. THORPE, C.B., Ph.D., F.R.S., and M. M. PATTISON MUIR, M.A. and F.R.S.E. With Plate of Spectra and 57 Illustrations. Fcp. 8vo., 3s. 6d.
- INTRODUCTION TO THE STUDY OF CHEMICAL PHILOSOPHY.** By WILLIAM A. TILDEN, D.Sc., London, F.R.S. With 5 Illustrations. With or without Answers to Problems. Fcp. 8vo., 4s. 6d.
- ELEMENTS OF ASTRONOMY.** By Sir R. S. BALL, LL.D., F.R.S. With 130 Illustrations. Fcp. 8vo., 6s. 6d.
- SYSTEMATIC MINERALOGY.** By HILARY BAUERMAN, F.G.S. With 373 Illustrations. Fcp. 8vo., 6s.
- DESCRIPTIVE MINERALOGY.** By HILARY BAUERMAN, F.G.S., etc. With 236 Illustrations. Fcp. 8vo., 6s.
- METALS: THEIR PROPERTIES AND TREATMENT.** By A. K. HUNTINGTON and W. G. McMILLAN. With 122 Illustrations. Fcp. 8vo., 7s. 6d.
- THEORY OF HEAT.** By J. CLERK MAXWELL, M.A., LL.D., Edin., F.R.S.S., L. & E. With 38 Illustrations. Fcp. 8vo., 4s. 6d.
- PRACTICAL PHYSICS.** By R. T. GLAZEBROOK, M.A., F.R.S., and W. N. SHAW, M.A. With 134 Illustrations. Fcp. 8vo. 7s. 6d.
- PRELIMINARY SURVEY AND ESTIMATES.** By THEODORE GRAHAM GRIBBLE, Civil Engineer. Including Elementary Astronomy, Route Surveying, Tacheometry, Curve-ranging, Graphic Mensuration, Estimates, Hydrography and Instruments. With 133 Illustrations. Fcp. 8vo., 7s. 6d.
- ALGEBRA AND TRIGONOMETRY.** By WILLIAM NATHANIEL GRIFFIN, B.D. 3s. 6d. Notes on, with Solutions of the more difficult Questions. Fcp. 8vo., 3s. 6d.
- THE STEAM ENGINE.** By GEORGE C. V. HOLMES, Secretary of the Institution of Naval Architects. With 212 Illustrations. Fcp. 8vo., 6s.
- ELECTRICITY AND MAGNETISM.** By FLEEMING JENKIN, F.R.S.S., L. & E. With 177 Illustrations. Fcp. 8vo., 3s. 6d.
- THE ART OF ELECTRO-METALLURGY.** By G. GORE, LL.D., F.R.S. With 56 Illus. Fcp. 8vo., 6s.
- TELEGRAPHY.** By Sir W. H. PREECE, K.C.B., F.R.S., M.I.C.E., and Sir J. SIVEWRIGHT, M.A., K.C.M.G. With 267 Illustrations. Fcp. 8vo., 6s.
- PHYSICAL OPTICS.** By R. T. GLAZEBROOK, M.A., F.R.S. With 183 Illustrations. Fcp. 8vo., 6s.
- TECHNICAL ARITHMETIC AND MENSURATION.** By CHARLES W. MERRIEFIELD, F.R.S. 3s. 6d. Key, by the Rev. JOHN HUNTER, M.A. Fcp. 8vo., 3s. 6d.
- THE STUDY OF ROCKS.** By FRANK RUTLEY, F.G.S. With 6 Plates and 88 Illustrations. Fcp. 8vo., 4s. 6d.
- WORKSHOP APPLIANCES,** including Descriptions of some of the Machine Tools used by Engineers. By C. P. B. SHELLEY, M.I.C.E. With 323 Illustrations. Fcp. 8vo., 5s.
- ELEMENTS OF MACHINE DESIGN.** By W. CAWTHORNE UNWIN, F.R.S., B.Sc., M.I.C.E.
- PART I.** General Principles, Fastenings and Transmissive Machinery. With 345 Illustrations. Fcp. 8vo., 7s. 6d.
- PART II.** Chiefly on Engine Details. With 174 Illustrations. Fcp. 8vo., 4s. 6d.
- STRUCTURAL AND PHYSIOLOGICAL BOTANY.** By OTTO WILHELM THOMÉ, and A. W. BENNETT, M.A., B.Sc., F.L.S. With 600 Illustrations. Fcp. 8vo., 6s.
- PLANE AND SOLID GEOMETRY.** By H. W. WATSON, M.A. Fcp. 8vo. 5s. 6d.

ADVANCED SCIENCE MANUALS.

- BUILDING CONSTRUCTION.** By the Author of 'Rivington's Notes on Building Construction'. With 385 Illustrations and an Appendix of Examination Questions. Crown 8vo., 4s. 6d.
- THEORETICAL MECHANICS.** Solids, including Kinematics, Statics, and Kinetics. By A. THORNTON, M.A., F.R.A.S. With 220 Illustrations, 130 Worked Examples, and over 900 Examples from Examination Papers, etc. Crown 8vo., 4s. 6d.
- HEAT.** By MARK R. WRIGHT, Hon. Inter. B.Sc. (Lond.). With 136 Illustrations and numerous Examples and Examination Papers. Crown 8vo., 4s. 6d.
- LIGHT.** By W. J. A. EMTAGE, M.A. With 232 Illustrations. Cr. 8vo., 6s.
- MAGNETISM AND ELECTRICITY.** By ARTHUR WILLIAM POYSER, M.A. With 317 Illustrations. Crown 8vo., 4s. 6d.
- INORGANIC CHEMISTRY, THEORETICAL AND PRACTICAL.** A Manual for Students in Advanced Classes of the Science and Art Department. By WILLIAM JAGO, F.C.S., F.I.C. With Plate of Spectra and 78 Woodcuts. Crown 8vo., 4s. 6d.
- GEOLOGY:** a Manual for Students in Advanced Classes and for General Readers. By CHARLES BIRD, B.A. (Lond.), F.G.S. With over 300 Illustrations, a Geological Map of the British Isles (coloured), and a set of Questions for Examination. Crown 8vo., 7s. 6d.
- HUMAN PHYSIOLOGY:** a Manual for Students in advanced Classes of the Science and Art Department. By JOHN THORNTON, M.A. With 268 Illustrations, some of which are Coloured, and a set of Questions for Examination. Crown 8vo., 6s.
- PHYSIOGRAPHY.** By JOHN THORNTON, M.A. With 11 Maps, 255 Illustrations, and Coloured Map of Ocean Deposits. Crown 8vo., 4s. 6d.
- AGRICULTURE.** By HENRY J. WEBB, Ph.D., B.Sc. With 100 Illustrations. Crown 8vo., 7s. 6d. net.
- HYGIENE.** By J. LANE NOTTER, M.A., M.D., Professor of Hygiene in the Army Medical School, Netley, Colonel, Royal Army Medical Corps; and R. H. FIRTH, F.R.C.S., late Assistant Professor of Hygiene in the Army Medical School, Netley, Major, Royal Army Medical Corps. With 95 Illustrations. Crown 8vo., 3s. 6d.

ELEMENTARY SCIENCE MANUALS.

*** Written specially to meet the requirements of the ELEMENTARY STAGE OF SCIENCE SUBJECTS as laid down in the Syllabus of the Director of the BOARD OF EDUCATION.*

- PRACTICAL, PLANE, AND SOLID GEOMETRY,** including Graphic Arithmetic. By I. H. MORRIS. Fully Illustrated with Drawings. Crown 8vo., 2s. 6d.
- GEOMETRICAL DRAWING FOR ART STUDENTS.** Embracing Plane Geometry and its Applications, the Use of Scales, and the Plans and Elevations of Solids. By I. H. MERRIS. Crown 8vo., 1s. 6d.
- TEXT - BOOK ON PRACTICAL, SOLID, OR DESCRIPTIVE GEOMETRY.** By DAVID ALLAN LOW (Whitworth Scholar). Part I. Crown 8vo., 2s. Part II. Crown 8vo., 3s.
- AN INTRODUCTION TO MACHINE DRAWING AND DESIGN.** By DAVID ALLAN LOW. With 153 Illustrations. Crown 8vo., 2s. 6d.

ELEMENTARY SCIENCE MANUALS—Continued.

- BUILDING CONSTRUCTION AND DRAWING.** By EDWARD J. BURRELL. With 308 Illustrations and Working Drawings. Crown 8vo., 2s. 6d.
- AN ELEMENTARY COURSE OF MATHEMATICS.** Containing Arithmetic; Euclid (Book I., with Deductions and Exercises); and Algebra. Crown 8vo., 2s. 6d.
- THEORETICAL MECHANICS.** Including Hydrostatics and Pneumatics. By J. E. TAYLOR, M.A., B.Sc. With numerous Examples and Answers, and 175 Diagrams and Illustrations. Crown 8vo., 2s. 6d.
- THEORETICAL MECHANICS—SOLIDS.** By J. E. TAYLOR, M.A., B.Sc. (Lond.). With 163 Illustrations, 120 Worked Examples, and over 500 Examples from Examination Papers, etc. Crown 8vo., 2s. 6d.
- THEORETICAL MECHANICS—FLUIDS.** By J. E. TAYLOR, M.A., B.Sc. (Lond.). With 122 Illustrations, numerous Worked Examples, and about 500 Examples from Examination Papers, etc. Crown 8vo., 2s. 6d.
- A MANUAL OF MECHANICS.** With 138 Illustrations and Diagrams, and 188 Examples taken from Examination Papers, with Answers. By T. M. GOODEVE, M.A. Crown 8vo., 2s. 6d.
- SOUND, LIGHT, AND HEAT.** By MARK R. WRIGHT, M.A. With 160 Diagrams and Illustrations. Crown 8vo., 2s. 6d.
- METALLURGY: an Elementary Text-Book.** By E. L. RHEAD. With 94 Illustrations. Crown 8vo., 3s. 6d.
- PHYSICS.** Alternative Course. By MARK R. WRIGHT, M.A. With 242 Illustrations. Crown 8vo., 2s. 6d.
- MAGNETISM AND ELECTRICITY.** By A. W. POYSER, M.A. With 235 Illustrations. Crown 8vo., 2s. 6d.
- PROBLEMS AND SOLUTIONS IN ELEMENTARY ELECTRICITY AND MAGNETISM.** By W. SLINGO and A. BROOKER. Embracing a Complete Set of Answers to the South Kensington Papers for the years 1885-1899, and a Series of Original Questions. With 67 Original Illustrations. Crown 8vo., 2s.
- ORGANIC CHEMISTRY: the Fatty Compounds.** By R. LLOYD WHITELEY, F.I.C., F.C.S. With 45 Illustrations. Crown 8vo., 3s. 6d.
- INORGANIC CHEMISTRY, THEORETICAL AND PRACTICAL.** By WILLIAM JAGO, F.C.S., F.I.C. With 63 Illustrations and numerous Questions and Exercises. Fcp. 8vo. 2s. 6d.
- AN INTRODUCTION TO PRACTICAL INORGANIC CHEMISTRY.** By WILLIAM JAGO, F.C.S., F.I.C. Crown 8vo., 1s. 6d.
- PRACTICAL CHEMISTRY: the Principles of Qualitative Analysis.** By WILLIAM A. TILDEN, D.Sc. Fcp. 8vo., 1s. 6d.
- ELEMENTARY INORGANIC CHEMISTRY.** By WILLIAM FURNEAUX, F.R.G.S. Crown 8vo., 2s. 6d.
- ELEMENTARY GEOLOGY.** By CHARLES BIRD, B.A., F.G.S. With Coloured Geological Map of the British Islands, and 247 Illustrations. Crown 8vo., 2s. 6d.
- HUMAN PHYSIOLOGY.** By WILLIAM FURNEAUX, F.R.G.S. With 218 Illustrations. Crown 8vo., 2s. 6d.
- A COURSE OF PRACTICAL ELEMENTARY BIOLOGY.** By J. BIDGOOD, B.Sc. With 226 Illustrations. Crown 8vo., 4s. 6d.
- ELEMENTARY BOTANY, THEORETICAL AND PRACTICAL.** By HENRY EDMONDS, B.Sc. With 342 Illustrations. Crown 8vo., 2s. 6d.
- STEAM.** By WILLIAM RIPPER, Member of the Institution of Mechanical Engineers. With 142 Illustrations. Crown 8vo., 2s. 6d.
- ELEMENTARY PHYSIOGRAPHY.** By J. THORNTON, M.A. With 13 Maps and 295 Illustrations. With Appendix on Astronomical Instruments and Measurements. Crown 8vo., 2s. 6d.
- AGRICULTURE.** By HENRY J. WEBB, Ph.D. With 34 Illustrations. Crown 8vo., 2s. 6d.

THE LONDON SCIENCE CLASS-BOOKS.

Edited by G. CAREY FOSTER, F.R.S., and by Sir PHILIP MAGNUS, B.Sc., B.A., of the City and Guilds of London Institute.

- ASTRONOMY. By Sir ROBERT STAWELL BALL, LL.D., F.R.S. With 41 Diagrams. Fcp. 8vo., 1s. 6d.
- MECHANICS. By Sir ROBERT STAWELL BALL, LL.D., F.R.S. With 89 Diagrams. Fcp. 8vo., 1s. 6d.
- THE LAWS OF HEALTH. By W. H. CORFIELD, M.A., M.D., F.R.C.P. With 22 Illustrations. Fcp. 8vo., 1s. 6d.
- MOLECULAR PHYSICS AND SOUND. By FREDERICK GUTHRIE, F.R.S. With 91 Diagrams. Fcp. 8vo., 1s. 6d.
- GEOMETRY, CONGRUENT FIGURES. By O. HENRICI, Ph.D., F.R.S. With 141 Diagrams. Fcp. 8vo., 1s. 6d.
- ZOOLOGY OF THE INVERTEBRATE ANIMALS. By ALEXANDER MACALISTER, M.D. With 59 Diagrams. Fcp. 8vo., 1s. 6d.
- ZOOLOGY OF THE VERTEBRATE ANIMALS. By ALEXANDER MACALISTER, M.D. With 77 Diagrams. Fcp. 8vo., 1s. 6d.
- HYDROSTATICS AND PNEUMATICS. By Sir PHILIP MAGNUS, B.Sc., B.A. With 79 Diagrams. Fcp. 8vo., 1s. 6d. (To be had also with *Answers*, 2s.) The Worked Solutions of the Problems. 2s.
- BOTANY. Outlines of the Classification of Plants. By W. R. MCNAB, M.D. With 118 Diagrams. Fcp. 8vo., 1s. 6d.
- BOTANY. Outlines of Morphology and Physiology. By W. R. MCNAB, M.D. With 42 Diagrams. Fcp. 8vo., 1s. 6d.
- THERMODYNAMICS. By RICHARD WORMELL, M.A., D.Sc. With 41 Diagrams. Fcp. 8vo., 1s. 6d.

PRACTICAL ELEMENTARY SCIENCE SERIES.

- ELEMENTARY PRACTICAL PHYSIOGRAPHY. (Section I.) By JOHN THORNTON, M.A., Head Master of the Central Higher Grade School, Bolton. With 215 Illustrations and a Coloured Spectrum. Crown 8vo., 2s. 6d.
- ELEMENTARY PRACTICAL PHYSIOGRAPHY. (Section II.) A Course of Lessons and Experiments in Elementary Science for the Queen's Scholarship Examination. By JOHN THORNTON, M.A. With 98 Illustrations and a Series of Questions. Crown 8vo., 2s. 6d.
- PRACTICAL DOMESTIC HYGIENE. By J. LANE NOTTER, M.A., M.D., Professor of Hygiene in the Army Medical School, Netley, etc.; and R. H. FIRTH, F.R.C.S., late Assistant Professor of Hygiene in the Army Medical School, Netley, etc. With 83 Illustrations. Crown 8vo., 2s. 6d.
- A PRACTICAL INTRODUCTION TO THE STUDY OF BOTANY: Flowering Plants. By J. BRETLAND FARMER, F.R.S., M.A., Professor of Botany in the Royal College of Science, London. With 121 Illustrations. Crown 8vo., 2s. 6d.
- PRACTICAL MATHEMATICS. By A. G. CRACKNELL, M.A., B.Sc. Crown 8vo., 3s. 6d.
- ELEMENTARY PRACTICAL CHEMISTRY. By G. S. NEWTH, F.I.C., F.C.S., Demonstrator in the Royal College of Science, London, etc. With 108 Illustrations and 254 Experiments. Crown 8vo., 2s. 6d.
- ELEMENTARY PRACTICAL PHYSICS. By W. WATSON, B.Sc., Assistant Professor of Physics in the Royal College of Science, London, etc. With 120 Illustrations and 193 Exercises. Crown 8vo., 2s. 6d.
- ELEMENTARY PRACTICAL ZOOLOGY. By FRANK E. BEDDARD, M.A. Oxon., F.R.S., Prosector to the Zoological Society of London. With 93 Illustrations. Crown 8vo., 2s. 6d.
- THE ELEMENTS OF GEOMETRICAL DRAWING: an Elementary Text-book on Practical Plane Geometry, including an Introduction to Solid Geometry. By HENRY J. SPOONER, C.E., M.Inst.M.E., Director of the Polytechnic School of Engineering, etc. Crown 8vo., 3s. 6d.

5,000/7/01.





YC 12814

GENERAL LIBRARY - U.C. BERKELEY



8000916053

TH 556
178 -
92425

